

Final draft **ETSI EN 302 567** V2.2.1 (2021-05)



**HARMONISED EUROPEAN STANDARD**

**Multiple-Gigabit/s radio equipment  
operating in the 60 GHz band;  
Harmonised Standard for access to radio spectrum**

---

**Reference**REN/BRAN-230018

---

**Keywords**access, broadband, LAN, radio, SRD, testing

---

**ETSI**650 Route des Lucioles  
F-06921 Sophia Antipolis Cedex - FRANCE

---

Tel.: +33 4 92 94 42 00 Fax: +33 4 93 65 47 16

Siret N° 348 623 562 00017 - APE 7112B  
Association à but non lucratif enregistrée à la  
Sous-Préfecture de Grasse (06) N° w061004871

---

**Important notice**

---

The present document can be downloaded from:

<http://www.etsi.org/standards-search>

The present document may be made available in electronic versions and/or in print. The content of any electronic and/or print versions of the present document shall not be modified without the prior written authorization of ETSI. In case of any existing or perceived difference in contents between such versions and/or in print, the prevailing version of an ETSI deliverable is the one made publicly available in PDF format at [www.etsi.org/deliver](http://www.etsi.org/deliver).

Users of the present document should be aware that the document may be subject to revision or change of status.

Information on the current status of this and other ETSI documents is available at

<https://portal.etsi.org/TB/ETSIDeliverableStatus.aspx>

If you find errors in the present document, please send your comment to one of the following services:

<https://portal.etsi.org/People/CommitteeSupportStaff.aspx>

---

**Notice of disclaimer & limitation of liability**

---

The information provided in the present deliverable is directed solely to professionals who have the appropriate degree of experience to understand and interpret its content in accordance with generally accepted engineering or other professional standard and applicable regulations.

No recommendation as to products and services or vendors is made or should be implied.

In no event shall ETSI be held liable for loss of profits or any other incidental or consequential damages.

Any software contained in this deliverable is provided "AS IS" with no warranties, express or implied, including but not limited to, the warranties of merchantability, fitness for a particular purpose and non-infringement of intellectual property rights and ETSI shall not be held liable in any event for any damages whatsoever (including, without limitation, damages for loss of profits, business interruption, loss of information, or any other pecuniary loss) arising out of or related to the use of or inability to use the software.

---

**Copyright Notification**

---

No part may be reproduced or utilized in any form or by any means, electronic or mechanical, including photocopying and microfilm except as authorized by written permission of ETSI.

The content of the PDF version shall not be modified without the written authorization of ETSI.

The copyright and the foregoing restriction extend to reproduction in all media.

© ETSI 2021.  
All rights reserved.

# Contents

Intellectual Property Rights .....	6
Foreword.....	6
Modal verbs terminology.....	7
Introduction .....	7
1 Scope .....	8
2 References .....	8
2.1 Normative references .....	8
2.2 Informative references.....	8
3 Definition of terms, symbols and abbreviations.....	9
3.1 Terms.....	9
3.2 Symbols.....	10
3.3 Abbreviations .....	10
4 Technical requirements specifications .....	11
4.1 Environmental profile.....	11
4.2 Conformance requirements .....	11
4.2.1 Spectral power density.....	11
4.2.1.0 Applicability.....	11
4.2.1.1 Definition .....	11
4.2.1.2 Limit.....	11
4.2.1.3 Conformance.....	11
4.2.2 RF output power .....	11
4.2.2.0 Applicability.....	11
4.2.2.1 Definition .....	11
4.2.2.2 Limit.....	11
4.2.2.3 Conformance.....	12
4.2.3 Transmitter unwanted emissions in the spurious domain .....	12
4.2.3.0 Applicability.....	12
4.2.3.1 Definition .....	12
4.2.3.2 Limit.....	12
4.2.3.3 Conformance.....	12
4.2.4 Receiver unwanted emissions .....	13
4.2.4.0 Applicability.....	13
4.2.4.1 Definition .....	13
4.2.4.2 Limit.....	13
4.2.4.3 Conformance.....	13
4.2.5 Adaptivity (medium access protocol) .....	13
4.2.5.1 Applicability.....	13
4.2.5.2 Definition .....	13
4.2.5.3 Requirement .....	13
4.2.5.4 Conformance.....	14
4.2.6 Short Control Signalling Transmissions .....	14
4.2.6.1 Applicability.....	14
4.2.6.2 Definition .....	14
4.2.6.3 Limits .....	14
4.2.6.4 Conformance.....	14
4.2.7 Receiver Adjacent Channel Rejection .....	14
4.2.7.1 Applicability.....	14
4.2.7.2 Definition .....	15
4.2.7.3 Performance Criteria .....	15
4.2.7.4 Limits .....	15
4.2.7.5 Conformance.....	15
4.2.8 Transmitter unwanted emissions in the out-of-band domain .....	15
4.2.8.0 Applicability.....	15
4.2.8.1 Definition .....	15

4.2.8.2	Limit.....	15
4.2.8.3	Conformance.....	16
4.2.9	Void.....	16
4.2.10	Occupied Channel Bandwidth.....	16
4.2.10.1	Applicability.....	16
4.2.10.2	Definition.....	16
4.2.10.3	Requirements.....	16
4.2.10.4	Conformance.....	16
4.2.11	Receiver Sensitivity level.....	17
4.2.11.1	Applicability.....	17
4.2.11.2	Definition.....	17
4.2.11.3	Limits.....	17
4.2.11.4	Conformance.....	17
5	Testing for compliance with technical requirements.....	17
5.1	Environmental conditions for testing.....	17
5.1.1	Introduction.....	17
5.1.2	Normal test conditions.....	17
5.1.2.1	Normal temperature and humidity.....	17
5.1.2.2	Normal power source.....	17
5.1.3	Extreme test conditions.....	18
5.2	Void.....	18
5.3	Test procedure for the essential radio test suites.....	18
5.3.0	General.....	18
5.3.1	Product Information.....	18
5.3.2	Test modulation, frequency and configuration.....	18
5.3.3	Spectral power density.....	19
5.3.3.1	Test conditions.....	19
5.3.3.2	Test method.....	19
5.3.4	RF output power.....	20
5.3.4.1	Test conditions.....	20
5.3.4.2	Test method.....	20
5.3.5	Transmitter unwanted emissions in the spurious domain.....	21
5.3.5.0	Test conditions.....	21
5.3.5.1	Pre-scan.....	21
5.3.5.2	Identified emissions.....	22
5.3.6	Receiver unwanted emissions.....	23
5.3.6.0	Test conditions.....	23
5.3.6.1	Pre-scan.....	23
5.3.6.2	Identified emissions.....	23
5.3.7	Receiver Adjacent Channel Rejection.....	24
5.3.7.1	Test conditions.....	24
5.3.7.2	Test Method.....	24
5.3.8	Adaptivity (medium access protocol).....	25
5.3.8.1	Test conditions.....	25
5.3.8.2	Test method.....	25
5.3.8.3	Generic test procedure for measuring channel/frequency usage.....	27
5.3.9	Transmitter unwanted emissions in the out-of-band domain.....	28
5.3.9.1	Test conditions.....	28
5.3.9.2	Test method.....	28
5.3.10	Occupied Channel Bandwidth.....	29
5.3.10.1	Test conditions.....	29
5.3.10.2	Test method.....	29
5.3.11	Receiver sensitivity level.....	29
5.3.11.1	Test conditions.....	29
5.3.11.2	Test method.....	29

<b>Annex A (informative):</b>	<b>Relationship between the present document and the essential requirements of Directive 2014/53/EU.....</b>	<b>31</b>
-------------------------------	--	-----------

<b>Annex B (informative):</b>	<b>Maximum Measurement Uncertainty.....</b>	<b>33</b>
-------------------------------	---	-----------

<b>Annex C (normative):</b>	<b>Test sites and arrangements for radiated measurements.....</b>	<b>34</b>
C.1	Test sites .....	34
C.1.1	Open air test sites .....	34
C.1.2	Anechoic chamber .....	35
C.1.2.1	General.....	35
C.1.2.2	Description.....	35
C.1.2.3	Influence of parasitic reflections.....	35
C.1.2.4	Calibration and mode of use .....	35
C.2	Test antenna.....	37
C.3	Substitution antenna .....	37
<b>Annex D (normative):</b>	<b>General description of measurement .....</b>	<b>38</b>
D.1	Radiated measurements.....	38
D.2	Substitution measurement .....	39
<b>Annex E (informative):</b>	<b>Bibliography.....</b>	<b>40</b>
<b>Annex F (informative):</b>	<b>Change History .....</b>	<b>41</b>
History .....		42

# Intellectual Property Rights

## Essential patents

IPRs essential or potentially essential to normative deliverables may have been declared to ETSI. The declarations pertaining to these essential IPRs, if any, are publicly available for **ETSI members and non-members**, and can be found in ETSI SR 000 314: "*Intellectual Property Rights (IPRs); Essential, or potentially Essential, IPRs notified to ETSI in respect of ETSI standards*", which is available from the ETSI Secretariat. Latest updates are available on the ETSI Web server (<https://ipr.etsi.org/>).

Pursuant to the ETSI Directives including the ETSI IPR Policy, no investigation regarding the essentiality of IPRs, including IPR searches, has been carried out by ETSI. No guarantee can be given as to the existence of other IPRs not referenced in ETSI SR 000 314 (or the updates on the ETSI Web server) which are, or may be, or may become, essential to the present document.

## Trademarks

The present document may include trademarks and/or tradenames which are asserted and/or registered by their owners. ETSI claims no ownership of these except for any which are indicated as being the property of ETSI, and conveys no right to use or reproduce any trademark and/or tradename. Mention of those trademarks in the present document does not constitute an endorsement by ETSI of products, services or organizations associated with those trademarks.

**DECT™**, **PLUGTESTS™**, **UMTS™** and the ETSI logo are trademarks of ETSI registered for the benefit of its Members. **3GPP™** and **LTE™** are trademarks of ETSI registered for the benefit of its Members and of the 3GPP Organizational Partners. **oneM2M™** logo is a trademark of ETSI registered for the benefit of its Members and of the oneM2M Partners. **GSM®** and the GSM logo are trademarks registered and owned by the GSM Association.

# Foreword

This final draft Harmonised European Standard (EN) has been produced by ETSI Technical Committee Broadband Radio Access Networks (BRAN), and is now submitted for the Vote phase of the ETSI standards EN Approval Procedure.

The present document has been prepared under the Commission's standardisation request C(2015) 5376 final [i.2] to provide one voluntary means of conforming to the essential requirements of Directive 2014/53/EU on the harmonisation of the laws of the Member States relating to the making available on the market of radio equipment and repealing Directive 1999/5/EC [i.6].

Once the present document is cited in the Official Journal of the European Union under that Directive, compliance with the normative clauses of the present document given in table A.1 confers, within the limits of the scope of the present document, a presumption of conformity with the corresponding essential requirements of that Directive and associated EFTA regulations.

<b>Proposed national transposition dates</b>	
Date of latest announcement of this EN (doa):	3 months after ETSI publication
Date of latest publication of new National Standard or endorsement of this EN (dop/e):	6 months after doa
Date of withdrawal of any conflicting National Standard (dow):	18 months after doa

---

## Modal verbs terminology

In the present document "**shall**", "**shall not**", "**should**", "**should not**", "**may**", "**need not**", "**will**", "**will not**", "**can**" and "**cannot**" are to be interpreted as described in clause 3.2 of the [ETSI Drafting Rules](#) (Verbal forms for the expression of provisions).

"**must**" and "**must not**" are **NOT** allowed in ETSI deliverables except when used in direct citation.

---

## Introduction

60 GHz radio equipment are capable of operating at data rates of multiple-gigabit per second.

The spectrum usage conditions for this equipment are set in Commission Decision 2013/752/EU [i.4] and Commission Decision 2019/1345/EU [i.7] amending Commission Decision 2006/771/EC of 9 November 2006 [i.5] and ERC Recommendation 70-03 [i.3], annex 3.

# 1 Scope

The present document specifies technical characteristics and methods of measurements for radio equipment with integral antennas operating indoor or outdoor at data rates of multiple-gigabit per second in the 60 GHz frequency range.

These radio equipment operate with very wideband communications using a variety of directional medium and high gain antennas to enable a high degree of spectrum reuse, and may use a flexible bandwidth scheme under which they normally operate in a wideband mode, and periodically reduce their bandwidth (e.g. for antenna training and other activities).

The technical characteristics of applications using these radio equipment are further described in ETSI TR 102 555 [i.1].

Equipment in this frequency range intended for outdoor Fixed Local Area Network Extension (FLANE) or Fixed Point-to-Point applications are not in the scope of the present document.

These radio equipment types are capable of operating in all or any part of the frequency bands given in table 1.

**Table 1: Radiocommunications service frequency band**

	<b>Radiocommunications service frequency band</b>
Transmit	57 GHz to 71 GHz
Receive	57 GHz to 71 GHz

NOTE: The relationship between the present document and essential requirements of article 3.2 of Directive 2014/53/EU [i.6] is given in annex A.

## 2 References

### 2.1 Normative references

References are either specific (identified by date of publication and/or edition number or version number) or non-specific. For specific references, only the cited version applies. For non-specific references, the latest version of the referenced document (including any amendments) applies.

Referenced documents which are not found to be publicly available in the expected location might be found at <https://docbox.etsi.org/Reference/>.

NOTE: While any hyperlinks included in this clause were valid at the time of publication, ETSI cannot guarantee their long term validity.

The following referenced documents are necessary for the application of the present document.

Not applicable.

### 2.2 Informative references

References are either specific (identified by date of publication and/or edition number or version number) or non-specific. For specific references, only the cited version applies. For non-specific references, the latest version of the referenced document (including any amendments) applies.

NOTE: While any hyperlinks included in this clause were valid at the time of publication, ETSI cannot guarantee their long term validity.



The following referenced documents are not necessary for the application of the present document but they assist the user with regard to a particular subject area.

- [i.1] ETSI TR 102 555: "Electromagnetic compatibility and Radio spectrum Matters (ERM); Technical characteristics of multiple gigabit wireless systems in the 60 GHz range System Reference Document".
- [i.2] Commission Implementing Decision C(2015) 5376 final of 4.8.2015 on a standardisation request to the European Committee for Electrotechnical Standardisation and to the European Telecommunications Standards Institute as regards radio equipment in support of Directive 2014/53/EU of the European Parliament and of the Council.
- [i.3] ERC Recommendation 70-03 (Tromsø 1997 and subsequent amendments): "Related to the Use of Short Range Devices (SRD)".
- [i.4] Commission Implementing Decision 2013/752/EU of 11 December 2013 amending Decision 2006/771/EC on harmonisation of the radio spectrum for use by short-range devices and repealing Decision 2005/928/EC (notified under document C(2013) 8776) Text with EEA relevance.
- [i.5] Commission Decision 2006/771/EC of 9 November 2006 on harmonisation of the radio spectrum for use by short-range devices.
- [i.6] Directive 2014/53/EU of the European Parliament and of the Council of 16 April 2014 on the harmonisation of the laws of the Member States relating to the making available on the market of radio equipment and repealing Directive 1999/5/EC.
- [i.7] Commission Implementing Decision (EU) 2019/1345 of 2 August 2019 amending Decision 2006/771/EC updating harmonised technical conditions in the area of radio spectrum use for short-range devices (notified under document C(2019) 5660) Text with EEA relevance.
- [i.8] IEEE 802.11-2020™: "Wireless LAN Medium Access Control (MAC) and Physical Layer (PHY) Specifications".
- [i.9] ITU-R Radio Regulations.
- [i.10] ERC Recommendation 74-01 (1998 and subsequent amendments): "Unwanted emissions in the spurious domain".

---

## 3 Definition of terms, symbols and abbreviations

### 3.1 Terms

For the purposes of the present document, the terms given in Directive 2014/53/EU [i.6] and the following apply:

**60 GHz range or 60 GHz band:** one of the variously permitted frequencies of operation, between 57 GHz to 71 GHz

**activity factor:** percentage over any one minute time period when equipment is operating under a given set of conditions

**adjacent channel:** channels on either side of the nominal channel separated by the nominal channel bandwidth

**channel separation:** minimum separation (in MHz) between the centre frequencies of two adjacent channels in the channel plan of the radio equipment

**integral antenna:** antenna which is declared to be part of the radio equipment by the manufacturer

NOTE 1: In some cases, it may not be possible to remove an integral antenna or expose an antenna connector without changing the output characteristics of the radio equipment.

NOTE 2: Even with an integral antenna, it might still be possible to separate the antenna from the equipment using a special tool.

**mean power:** average power (transmitted or received) during the On Time of the signal

**nominal channel bandwidth:** bandwidth assigned to a single channel

NOTE: The nominal channel bandwidth is declared by the manufacturer as outlined in clause 5.3.1.

**occupied bandwidth:** bandwidth of the signal containing 99 % of the transmitted mean power

NOTE: Both below the lower and above the upper frequency limits, the mean power emitted is equal to 0,5 % of the total mean power of the emission.

**operating channel:** channel on which the RLAN equipment has started the Adaptivity mechanism to start transmissions

**smart antenna system:** equipment that combines multiple transmit and/or receive antenna elements with a signal processing function to increase its radiation and/or reception capabilities

NOTE: This includes techniques such as spatial multiplexing, beam forming, cyclic delay diversity, etc.

## 3.2 Symbols

For the purposes of the present document, the following symbols apply:

dBc	decibel relative to the maximum spectral power density of the transmitted signal
dBm	decibel relative to one milliwatt
dBr	decibel relative to a given maximum power level
f	frequency
GHz	thousand millions of cycles per second
kHz	thousands of cycles per second
μs	millionths of second
W	watt power unit

## 3.3 Abbreviations

For the purposes of the present document, the following abbreviations apply:

BW	BandWidth
CCA	Clear Channel Assessment
CW	Continuous Wave
EFTA	European Free Trade Association
EIRP	Equivalent Isotropically Radiated Power
ERP	Effective Radiated Power
FER	Frame Error Rate
FLANE	Fixed Local Area Network Extension
LBT	Listen Before Talk
MCS	Modulation and Coding Scheme
PD	Power Density
PDL	spectral Power Density Limit
RBW	Resolution BandWidth
RF	Radio Frequency
RMS	Root Mean Square
STA	Station
TXOP	Transmit Opportunity
UUT	Unit Under Test
VBW	Video BandWidth

## 4 Technical requirements specifications

### 4.1 Environmental profile

The technical requirements of the present document apply under the environmental profile for operation of the equipment, which shall be in accordance with its intended use. The equipment shall comply with all the technical requirements of the present document at all times when operating within the boundary limits of the operational environmental profile defined by its intended use.

### 4.2 Conformance requirements

#### 4.2.1 Spectral power density

##### 4.2.1.0 Applicability

The present requirement applies to all equipment within the scope of the present document.

##### 4.2.1.1 Definition

The spectral power density is the mean Equivalent Isotropically Radiated Power (EIRP) density during a transmission burst.

##### 4.2.1.2 Limit

The maximum spectral power density is applicable to the system as a whole when operated at the highest power spectral density level (EIRP). The maximum spectral power density shall be as indicated in table 2.

**Table 2: Spectral Power Density Limit (PDL)**

Maximum spectral power density (EIRP)
23 dBm/MHz

##### 4.2.1.3 Conformance

Conformance tests as defined in clause 5.3.3 shall be carried out and result compared to the limit.

#### 4.2.2 RF output power

##### 4.2.2.0 Applicability

The present requirement applies to all equipment within the scope of the present document.

##### 4.2.2.1 Definition

The RF output power is the mean Equivalent Isotropically Radiated Power (EIRP) for the equipment during a transmission burst.

##### 4.2.2.2 Limit

The maximum RF output power is applicable to the system as a whole when operated at the highest stated power level. For a smart antenna system, the limit applies to the configuration that results in the highest EIRP. In case of multiple (adjacent or non-adjacent) channels the total RF output power of all channels shall be less than or equal to the limits in table 3.

The maximum RF output power shall be as indicated in table 3.

**Table 3: RF output power limit**

Maximum power level (EIRP)
40 dBm

#### 4.2.2.3 Conformance

Conformance tests as defined in clause 5.3.4 shall be carried out and result compared to the limit.

### 4.2.3 Transmitter unwanted emissions in the spurious domain

#### 4.2.3.0 Applicability

The present requirement applies to all equipment within the scope of the present document.

#### 4.2.3.1 Definition

Transmitter spurious emissions are emissions on a frequency, or frequencies, which are outside the necessary bandwidth and the level of which may be reduced without affecting the corresponding transmission of information. Spurious emissions include harmonic emissions, parasitic emissions, intermodulation products and frequency conversion products but exclude out-of-band emissions (article 1, No. 1.145 of the ITU-R Radio Regulations [i.9]).

The lower boundary between the spurious domain and the out-of-band domain shall be at a frequency  $F_l$ :

- $F_l = \min(57 \text{ GHz}; f_c - \min(2,5 \times \text{nominal channel BW}, 1,5 \times \text{nominal channel BW} + 0,5 \text{ GHz}))$

where  $f_c$  is the nominal centre frequency of the transmission.

The upper boundary between the spurious domain and the out-of-band domain shall be at a frequency  $F_h$ :

- $F_h = \max(71 \text{ GHz}; f_c + \min(2,5 \times \text{nominal channel BW}, 1,5 \times \text{nominal channel BW} + 0,5 \text{ GHz}))$

#### 4.2.3.2 Limit

The level of unwanted emissions in the spurious domain shall be less than or equal to the limits given in table 4.

**Table 4: Transmitter spurious emissions**

Frequency range	Emission Limit ERP ( $\leq 1$ GHz) EIRP ( $> 1$ GHz)	Measurement Bandwidth
$30 \text{ MHz} \leq f < 87,5 \text{ MHz}$	-36 dBm	100 kHz
$87,5 \text{ MHz} \leq f \leq 118 \text{ MHz}$	-54 dBm	100 kHz
$118 \text{ MHz} < f < 174 \text{ MHz}$	-36 dBm	100 kHz
$174 \text{ MHz} \leq f \leq 230 \text{ MHz}$	-54 dBm	100 kHz
$230 \text{ MHz} < f < 470 \text{ MHz}$	-36 dBm	100 kHz
$470 \text{ MHz} \leq f \leq 694 \text{ MHz}$	-54 dBm	100 kHz
$694 \text{ MHz} < f \leq 1 \text{ GHz}$	-36 dBm	100 kHz
$1 \text{ GHz} < f < F_l \text{ GHz}$	-30 dBm	1 MHz
$F_h \text{ GHz} < f < 142 \text{ GHz}$	-30 dBm	1 MHz

NOTE: Information in this table is based on ERC Recommendation 74-01 [i.10].

#### 4.2.3.3 Conformance

Conformance tests as defined in clause 5.3.5 shall be carried out and result compared to the limit.

## 4.2.4 Receiver unwanted emissions

### 4.2.4.0 Applicability

The present requirement applies to all equipment within the scope of the present document.

### 4.2.4.1 Definition

These are unwanted emissions in the spurious domain while the equipment is receiving a transmission.

### 4.2.4.2 Limit

The level of unwanted emissions in the spurious domain shall be less than or equal to the limits given in table 5.

**Table 5: Receiver spurious emissions**

Frequency band	Emission Limit ERP ( $\leq 1$ GHz) EIRP ( $> 1$ GHz)	Measurement Bandwidth
$30 \text{ MHz} \leq f \leq 1 \text{ GHz}$	-57 dBm	100 kHz
$1 \text{ GHz} < f \leq 142 \text{ GHz}$	-47 dBm	1 MHz
NOTE: Information in this table is based on ERC Recommendation 74-01 [i.10].		

### 4.2.4.3 Conformance

Conformance tests as defined in clause 5.3.6 shall be carried out and result compared to the limit.

## 4.2.5 Adaptivity (medium access protocol)

### 4.2.5.1 Applicability

The present requirement applies to all equipment within the scope of the present document.

### 4.2.5.2 Definition

Adaptivity (medium access protocol) is a mechanism designed to facilitate spectrum sharing with other devices.

### 4.2.5.3 Requirement

Adaptivity (medium access protocol) shall be implemented by the equipment and shall be active under all circumstances.

LBT is mandatory to facilitate spectrum sharing.

The LBT mechanism is as follows:

- 1) Before a single transmission or a burst of transmissions on an Operating Channel, the equipment that initiates transmission shall perform a Clear Channel Assessment (CCA) Check in the Operating Channel.
- 2) If it finds an Operating Channel occupied, it shall not transmit in that channel and it shall not enable other equipment(s) to transmit in that channel. If the CCA check has determined the channel to be no longer occupied and transmission was deferred for the number of empty slots defined by the CCA Check procedure, it may resume transmissions or enable other equipment to transmit on this channel.
- 3) The equipment that initiates transmission shall perform the CCA check using "energy detect". The Operating Channel shall be considered occupied for a slot time of 5  $\mu$ s if the energy level in the channel exceeds the threshold corresponding to the power level given in step 7) below. It shall observe the Operating Channel(s) for the duration of the CCA observation time measured by multiple slot times.

- 4) CCA Check definition:
  - a) A CCA check is initiated at the end of an operating channel occupied slot time.
  - b) Upon observing that Operating Channel was not occupied for a minimum of 8  $\mu$ s, transmission deferring shall occur.
  - c) The transmission deferring shall last for a minimum of random (0 to Max number) number of empty slots periods.
  - d) Max number shall not be lower than 3.
- 5) The total time that the equipment initiating transmission makes use of an Operating Channel is defined as the **Channel Occupancy Time**. This Channel Occupancy Time shall be less than 5 ms, after which it shall perform a new CCA Check as described in step 1), step 2) and step 3) above.
- 6) An equipment (initiating or not initiating transmission), upon correct reception of a packet which was intended for this equipment, can skip the CCA Check, and immediately proceed with the transmission in response to received frames. A consecutive sequence of transmissions by the equipment, without a new CCA Check, shall not exceed the 5 ms Channel Occupancy Time as defined in step 5) above.
- 7) The energy detection threshold for the CCA Check shall be  $-80 \text{ dBm} + 10 \times \log_{10} (\text{Operating Channel Bandwidth (in MHz)}) + 10 \times \log_{10} (P_{\text{max}} / P_{\text{out}})$  ( $P_{\text{max}}$  and  $P_{\text{out}}$  in W EIRP) where  $P_{\text{out}}$  is the RF output power (EIRP) and  $P_{\text{max}}$  is the RF output power limit defined in clause 4.2.2.1.

#### 4.2.5.4 Conformance

The conformance tests as defined in clause 5.3.8 shall be carried out.

### 4.2.6 Short Control Signalling Transmissions

#### 4.2.6.1 Applicability

The present requirement shall apply to all equipment within the scope of the present document.

#### 4.2.6.2 Definition

Short Control Signalling Transmissions are transmissions used by the equipment to send management and control frames without sensing the channel for the presence of other signals.

#### 4.2.6.3 Limits

The use of Short Control Signalling Transmissions shall be constrained as follows:

- within an observation period of 100 ms;
- the total duration of the equipment's Short Control Signalling Transmissions shall be less than 10 ms within said observation period.

#### 4.2.6.4 Conformance

The conformance tests as defined in clause 5.3.8 shall be carried out.

### 4.2.7 Receiver Adjacent Channel Rejection

#### 4.2.7.1 Applicability

The present requirement applies to all equipment within the scope of the present document.

#### 4.2.7.2 Definition

The receiver adjacent channel rejection is a measure of the receiver's ability to receive a wanted signal at its assigned channel frequency in the presence of an unwanted signal at a given frequency offset from the centre frequency of the assigned channel, without this unwanted signal causing a degradation of the performance of the receiver beyond minimum performance criteria as specified in clause 4.2.7.3.

#### 4.2.7.3 Performance Criteria

The minimum performance criterion shall be a FER of less than or equal to 10 %.

#### 4.2.7.4 Limits

While maintaining the minimum performance criteria as defined in clause 4.2.7.3 the levels of the unwanted signal power shall be equal to or greater than the limits defined in table 6. The unwanted signal power is the smaller of -65 dBm and  $P_{\min}$  (dBm) + 8 dB where  $P_{\min}$  is the minimum level of the wanted signal required to meet the minimum performance criteria in the absence of any interference signal.

**Table 6: Receiver Adjacent Channel Rejection level**

Wanted signal mean power from companion device (dBm) at the input of UUT	Unwanted signal frequency (GHz)	Unwanted signal power (dBm) at the input of UUT	Type of unwanted signal
$P_{\min} + 6$ dB	Operating Channel Centre Frequency - Nominal Channel BW	$\min(-65, P_{\min} + 8)$ dB	CW
$P_{\min} + 6$ dB	Operating Channel Centre Frequency + Nominal Channel BW	$\min(-65, P_{\min} + 8)$ dB	CW

#### 4.2.7.5 Conformance

The conformance tests as defined in clause 5.3.7 shall be carried out and result compared to the limit.

### 4.2.8 Transmitter unwanted emissions in the out-of-band domain

#### 4.2.8.0 Applicability

The present requirement applies to all equipment within the scope of the present document.

#### 4.2.8.1 Definition

Transmitter unwanted emissions in the out-of-band domain are emissions when the equipment is in transmit mode, on frequencies immediately outside the necessary bandwidth which results from the modulation process, but excluding spurious emissions.

#### 4.2.8.2 Limit

The transmitter unwanted emissions in the out-of-band domain shall be less than or equal to the relative limits provided in figure 1 (reference to IEEE 802.11-2020™ [i.8]) where BW represents the declared nominal channel BW or an absolute level of -30 dBm with a 1 MHz measurement bandwidth, whichever is the greater. Non-adjacent channels shall be tested separately.  $\pm A$  (see figure 1) corresponds to the frequency offset from the nominal centre frequency of the transmission by  $\pm 250$  % of the nominal channel BW for nominal channel BW  $\leq 500$  MHz and  $\pm (500 \text{ MHz} + 1,5 \times \text{nominal channel BW})$  for nominal channel BW  $> 500$  MHz. Within the 60 GHz band and outside -A to +A range the -30 dB<sub>r</sub> or -30 dBm in a 1 MHz whichever is the greater shall apply.

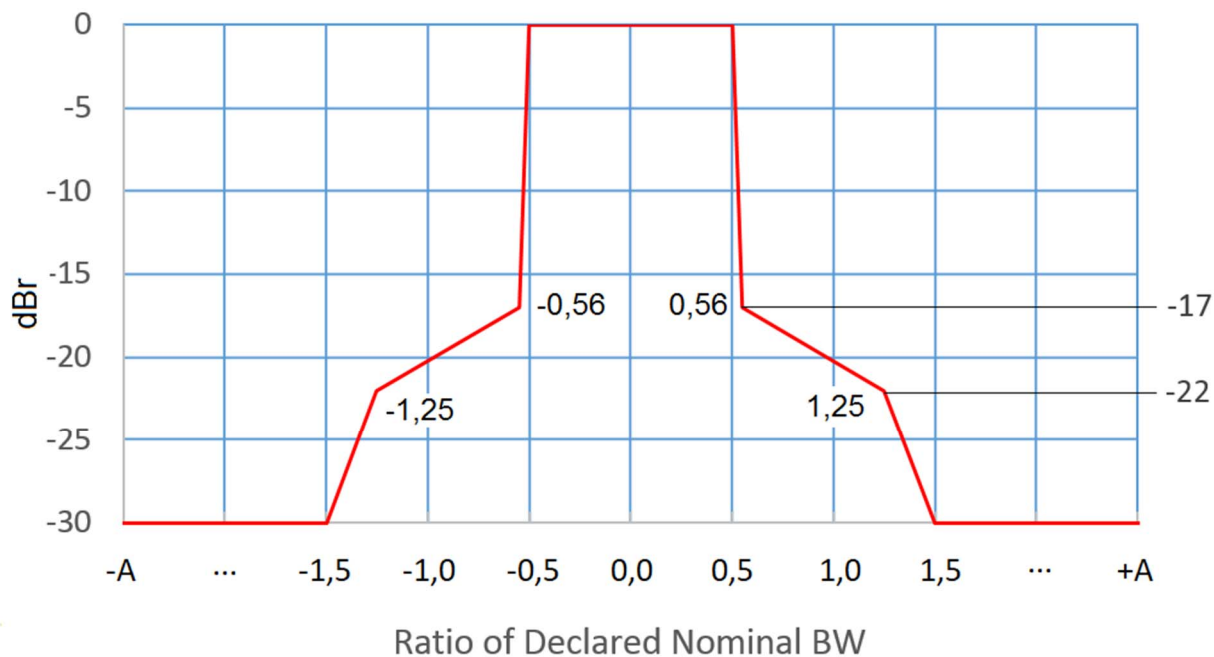

**Figure 1: Transmit Mask**

#### 4.2.8.3 Conformance

Conformance tests as defined in clause 5.3.9 shall be carried out and result compared to the limit.

#### 4.2.9 Void

#### 4.2.10 Occupied Channel Bandwidth

##### 4.2.10.1 Applicability

This requirement applies to all equipment within the scope of the present document.

##### 4.2.10.2 Definition

The Occupied Channel Bandwidth is the bandwidth containing 99 % of the power of the signal.

When equipment has simultaneous transmissions in adjacent channels, these transmissions may be considered as one signal with an actual nominal channel bandwidth of "n" times the individual nominal channel bandwidth where "n" is the number of adjacent channels. When equipment has simultaneous transmissions in non-adjacent channels, each power envelope shall be considered separately.

##### 4.2.10.3 Requirements

The Occupied Channel Bandwidth shall be less than the declared nominal Channel Bandwidth for all transmissions. The device shall support a mode of transmission with a necessary bandwidth as defined in ITU-R Radio Regulations 1.152 [i.9], (article 1), at least 70 % of the declared nominal channel bandwidth. In case of smart antenna systems (devices with multiple transmit chains) each of the transmit chains shall meet this requirement.

##### 4.2.10.4 Conformance

Conformance tests as defined in clause 5.3.10 shall be carried out and result compared to the limit.



## 4.2.11 Receiver Sensitivity level

### 4.2.11.1 Applicability

The present requirement applies to all equipment within the scope of the present document.

### 4.2.11.2 Definition

The receiver sensitivity level is the minimum mean power received at the UUT at which the performance criterion defined in clause 4.2.7.3 is met.

### 4.2.11.3 Limits

The measured sensitivity level shall not exceed  $-50 \text{ dBm} + 1,5 \times 10 \log_{10} (P_{\text{max}} / P_{\text{out}})$  ( $P_{\text{max}}$  and  $P_{\text{out}}$  in W EIRP) where  $P_{\text{out}}$  is the RF output power (EIRP) of the UUT and  $P_{\text{max}}$  the maximum possible RF output power as per clause 4.2.2.

### 4.2.11.4 Conformance

Conformance tests described in clause 5.3.11 shall be carried out.

---

# 5 Testing for compliance with technical requirements

## 5.1 Environmental conditions for testing

### 5.1.1 Introduction

Tests defined in the present document shall be carried out at representative points within the boundary limits of the operational environmental profile defined by its intended use.

Where technical performance varies subject to environmental conditions, tests shall be carried out under a sufficient variety of environmental conditions (within the boundary limits of the operational environmental profile defined by its intended use) to give confidence of compliance for the affected technical requirements.

For each test defined in the present document, the environmental condition(s) at which the test has to be performed is specified in the clause on test conditions for that particular test.

### 5.1.2 Normal test conditions

#### 5.1.2.1 Normal temperature and humidity

The normal temperature and humidity conditions for tests shall be any convenient combination of temperature and humidity within the following ranges:

- temperature: +15 °C to +35 °C;
- relative humidity: 20 % to 75 %.

The actual values during the tests shall be recorded.

#### 5.1.2.2 Normal power source

The normal test voltage for the equipment shall be the nominal voltage for which the equipment was designed.

### 5.1.3 Extreme test conditions

Some tests in the present document need to be repeated at extreme temperatures. Where that is the case, measurements shall be made over the extremes of the operating temperature range as declared by the manufacturer.

## 5.2 Void

## 5.3 Test procedure for the essential radio test suites

### 5.3.0 General

Radiated measurements shall be used for all tests outlined in clause 5.

#### 5.3.1 Product Information

The manufacturer should at the time of submission of the equipment for test, supply the following information to be recorded in the test report. The following information is required in order to carry out the test suites:

- a) The channel plan(s), being the centre frequencies that the UUT is capable of tuning. If the equipment is capable of supporting multiple channel plans in the course of normal operation (e.g. offering different sizes of normal wideband operation), each distinct channel plan and its related nominal channel bandwidth for normal wideband operation shall be stated.
- b) The test modulation(s) used by the UUT.
- c) Transmit and Receive Gain of the integral antenna including beamforming gain if supported.
- d) Minimum performance criteria as defined in clause 4.2.7 that corresponds to the intended use of the equipment. To be used also for clause 4.2.11.
- e) Nominal Channel BW.

#### 5.3.2 Test modulation, frequency and configuration

The test modulation used should be representative of normal use of the equipment. Where the equipment is not capable of continuous RF transmission, the test modulation shall be such that the generated RF transmission is the same for each transmission.

If the equipment uses multiple modulation methods with different RF characteristics, the modulation that produces the worst values for each essential radio test shall be used and this modulation shall be stated along with the rationale for why this modulation produces worse values than other modulation methods used by the equipment.

All tests shall be conducted at the following channels within the stated channel plan(s):

- a) The channel with the lowest operating frequency.
- b) The channel with the highest operating frequency.
- c) The channel with the frequency closest to the midpoint of the stated operating frequency range.

If the UUT is capable of supporting multiple nominal channel bandwidths for wideband normal operations, tests shall be conducted for each one of them.

The Channel Separation (ChS) value shall be calculated based on the minimum separation (in MHz) between any two centre channel frequencies in the channel plan.

In the case that the RF power level is adjustable, all measurements shall be made with the highest power level available.

In the case of smart antenna systems, the UUT should be configured to deliver the highest RF output power to the measurement equipment, and the method to do this shall be documented in the test report.

Radiated measurements shall be used in all cases given the use of integral antennas and the lack of suitable methods for conducted measurements for this type of equipment.

### 5.3.3 Spectral power density

#### 5.3.3.1 Test conditions

These measurements shall only be performed at normal test conditions.

The device shall be configured to operate at its maximum output power level.

Radiated measurement shall be performed in an anechoic chamber or open air test site, see annex C.

#### 5.3.3.2 Test method

The maximum spectral power density, subject to the conditions outlined in clause 5.1 and clause 5.3.2 shall be measured using a test site as described in annex C and the applicable measurement procedures in annex D. The maximum spectral power density shall be measured and recorded for conformance with the requirements in clause 4.2.1.

The maximum spectral power density shall be determined using a spectrum analyser of adequate bandwidth for the type of modulation being used in combination with a RF power meter.

For the purpose of this test, the minimum transmitter on time shall be 10  $\mu$ s. For equipment where the transmitter on time is less than 10  $\mu$ s, the method of measurement shall be documented in the test report.

The test procedure shall be as follows:

##### Step 1:

The spectrum analyser shall use the following settings:

- a) Centre frequency: The centre frequency of the channel under test.
- b) Resolution bandwidth: 1 MHz.
- c) Video bandwidth: 1 MHz.
- d) Frequency span:  $2 \times$  Nominal channel bandwidth.
- e) Detector: Peak.
- f) Trace mode: Max hold.

##### Step 2:

When the trace is complete, find the peak value of the power envelope and record the frequency.

##### Step 3:

Make the following changes to the settings of the spectrum analyser:

- a) Centre frequency: Equal to the frequency recorded in step 2.
- b) Resolution bandwidth: 1 MHz.
- c) Video bandwidth: 1 MHz.
- d) Frequency span: 3 MHz.
- e) Sweep time: 1 minute.
- f) Detector: RMS Average, Sample, or Average (excepting Video Average).
- g) Trace mode: Max hold.

For devices with a Nominal Channel bandwidth greater than 100 MHz, a Resolution BandWidth (RBW) other than 1 MHz as specified in step 3 may be used. This resolution bandwidth shall not be less than 1 MHz nor greater than 100 MHz. If a resolution bandwidth other than 1 MHz is employed, the power density limit that will be used in step 4 shall be  $PDL(RBW) = PDL(1 \text{ MHz}) + 10 \times \log_{10}(RBW)$  where RBW is the resolution bandwidth in MHz that is employed,  $PDL(1 \text{ MHz})$  is the power density limit at 1 MHz resolution bandwidth, and  $PDL(RBW)$  is the power density limit at the resolution bandwidth used. The video bandwidth shall be the same as the resolution bandwidth, and the frequency span shall be three times this substitute resolution bandwidth.

#### Step 4:

When the trace is complete, capture the trace, for example, using the "View" option on the spectrum analyser.

Find the peak value of the trace and place the analyser marker on this peak. This level is recorded as the highest spectral power density  $D$  in a 1 MHz band (or other substitute resolution as noted above).

Alternatively, where a spectrum analyser is equipment with a facility to measure spectral power density, this facility may be used to display the spectral power density  $D$  in dBm/1 MHz (or other substitute resolution as noted above).

The maximum EIRP spectral density is calculated from the above measured power density ( $D$ ) and the duty cycle  $x$  ( $0 < x \leq 1$ ), according to the formula below and shall be recorded in the test report. Note that  $PD$  is specified for a 1 MHz bandwidth unless a substitute resolution is used as noted above.

$$PD = D + 10 \times \log_{10}(1 / x).$$

Where the spectrum analyser bandwidth is non-Gaussian, a suitable correction factor shall be determined and applied.

The results obtained shall be compared to the limits in clause 4.2.1.2 in order to show compliance.

## 5.3.4 RF output power

### 5.3.4.1 Test conditions

These measurements shall only be performed at normal test conditions.

The device shall be configured to operate at its maximum output power level.

Radiated measurement shall be performed in an anechoic chamber or open air test site, see annex C.

### 5.3.4.2 Test method

The RF output power, subject to the conditions outlined in clause 5.1 and clause 5.3.2, shall be measured using a test site as described in annex C and applicable measurement procedures in annex D shall be measured and recorded for conformance with the requirements in clause 4.2.2.

The centre frequency of all equipment shall be verified as being in the 60 GHz band.

#### Step 1:

- a) Using suitable attenuators, the measurement equipment shall be coupled to a matched diode detector or equivalent thereof. The output of the diode detector shall be connected to the vertical channel of an oscilloscope or equivalent power measurement equipment.
- b) The combination of the diode detector and the oscilloscope shall be capable of faithfully reproducing the duty cycle of the transmitter output signal.
- c) The duty cycle of the transmitter (Tx on / (Tx on + Tx off)) shall be noted as  $x$  ( $0 < x \leq 1$ ), and recorded in the test report. For the purpose of testing, the equipment shall be operated with a duty cycle that is equal to or greater than 0,1.

**Step 2:**

- a) The RF output power of the transmitter when operated at the highest power level shall be measured using a spectrum analyser with an integration factor that exceeds the repetition period of the transmitter by a factor of 5 or more. The observed value shall be noted as "A" (in dBm).
- b) The EIRP shall be calculated from the above measured power output A (in dBm) and the duty cycle x according to the formula below shall be recorded.
- c)  $P = A + 10 \times \log_{10} (1 / x)$ .

The results obtained shall be compared to the limits in clause 4.2.1.2 in order to show compliance.

## 5.3.5 Transmitter unwanted emissions in the spurious domain

### 5.3.5.0 Test conditions

These measurements shall only be performed at normal test conditions.

The device shall be configured to operate at its maximum output power level.

Radiated measurement shall be performed in an anechoic chamber or open air test site, see annex C.

The transmitter unwanted emissions, subject to the conditions outlined in clause 5.1 and clause 5.3.2, shall be measured using a test site as described in annex C and applicable measurement procedures in annex D, shall be measured and recorded for conformance with the requirements in clause 4.2.3.

In case of radiated measurements on antenna array systems using symmetrical power distribution across the available transmit chains, the UUT should, where possible, be configured so that only one transmit chain (antenna) is activated while the other transmit chains are disabled. Where this is not possible, the method used shall be documented in the test report.

If only one transmit chain was tested, the result for the active transmit chain shall be corrected to be valid for the whole system (all transmit chains). The emission power (mW) for one transmit chain needs to be multiplied with the number of transmit chains to obtain the total emission power of the system.

For the purposes of these tests, the UUT shall be configured to operate at its maximum duty cycle and maximum RF output power level.

### 5.3.5.1 Pre-scan

The test procedure below shall be used to identify potential unwanted emissions of the UUT.

**Step 1:**

The sensitivity of the spectrum analyser should be such that the noise floor is at least 6 dB below the limits given in table 4.

**Step 2:**

The emissions shall be measured over the range 30 MHz to 1 GHz:

- a) Resolution bandwidth: 100 kHz.
- b) Video bandwidth: 100 kHz.
- c) Detector mode: Average.
- d) Trace mode: Max hold.
- e) Sweep time: For non-continuous transmissions, the sweep time shall be sufficiently long, such that for each 100 kHz frequency step, the measurement time is greater than two transmissions of the UUT.

The emissions shall be measured over the range 1 GHz to Fl and Fh to 142 GHz as defined in clause 4.2.3.1:

- a) Resolution bandwidth: 1 MHz.
- b) Video bandwidth: 1 MHz.
- c) Detector mode: Average.
- d) Trace mode: Max hold.
- e) Sweep time: For non-continuous transmissions, the sweep time shall be sufficiently long, such that for each 1 MHz frequency step, the measurement time is greater than two transmissions of the UUT.

Any emissions identified during the sweeps above that fall within the 6 dB range below the applicable limit shall be individually measured using the procedure in clause 5.3.5.2 and compared to the limits given in table 4. If measurements are conducted at a different distance than specified, then calculations for the equivalent field strength values shall be shown.

### 5.3.5.2 Identified emissions

Unwanted emissions within the lower spurious domain or the upper spurious domain that are identified during the pre-scan measurements above shall be accurately measured per the procedure below.

The lower spurious domain is defined as the range from the minimum frequency measured to Fl.

The upper spurious domain is defined as the range from Fh to the maximum frequency measured.

Step 1 and step 2 below shall be used to accurately measure the individual unwanted emissions identified during the pre-scan measurements above.

For continuous transmit signals, a measurement using the Video Average detector of the spectrum analyser is permitted. Otherwise, the measurement shall be made only over the "on" part of the transmission.

#### Step 1:

The level of the emissions shall be measured in the time domain, using the following spectrum analyser settings:

- a) Centre frequency: Frequency of emission identified during the pre-scan.
- b) Resolution bandwidth: 100 kHz if  $\leq 1$  GHz; 1 MHz if  $> 1$  GHz.
- c) Video bandwidth: 100 kHz if  $\leq 1$  GHz; 1 MHz if  $> 1$  GHz.
- d) Frequency span: 0 Hz.
- e) Sweep time: Suitable to capture one transmission burst.
- f) Trigger: Video trigger.
- g) Detector: Average.
- h) Trace mode: Clear write.

The centre frequency (fine tune) shall be adjusted to capture the highest level of one burst of the emission to be measured.

#### Step 2:

Change the following setting on the spectrum analyser:

- a) Detector: Video average, minimum of 100 sweeps.

The measured value is the average power of this emission during the on-time of the burst. The value shall be recorded and compared with the limit in table 4.

## 5.3.6 Receiver unwanted emissions

### 5.3.6.0 Test conditions

These measurements shall only be performed at normal test conditions.

Radiated measurement shall be performed in an anechoic chamber or open air test site, see annex C.

The receiver unwanted emissions, subject to the conditions outlined in clause 5.1 and clause 5.3.2, shall be measured using a test site as described in annex C and applicable measurement procedures in annex D, shall be measured and recorded for conformance with the requirements in clause 4.2.4.

In case of radiated measurements on antenna array systems using identical receive chains, the UUT should, where possible, be configured so that only one receive chain (antenna) is activated while the other receive chains are disabled. Where this is not possible, the method used shall be documented in the test report.

If only one receive chain was tested, the result for the active receive chain shall be corrected to be valid for the whole system (all receive chains).

The emission power for one receive chain needs to be multiplied with the number of receive chains to obtain the total emission power of the system.

The UUT shall be configured to a continuous receive mode or operated in a mode where no transmission occur.

### 5.3.6.1 Pre-scan

The test procedure below shall be used to identify potential unwanted emissions of the UUT.

#### Step 1:

The sensitivity of the spectrum analyser should be such that the noise floor is at least 6 dB below the limits given in table 5.

#### Step 2:

The emissions shall be measured over the range 30 MHz to 1 GHz:

- a) Resolution bandwidth: 100 kHz.
- b) Video bandwidth: 100 kHz.
- c) Detector mode: Average.
- d) Trace mode: Max hold.

The emissions shall be measured over the range >1 GHz to 142 GHz:

- a) Resolution bandwidth: 1 MHz.
- b) Video bandwidth: 1 MHz.
- c) Detector mode: Average.
- d) Trace mode: Max hold.

Any emissions identified during the sweeps above that fall within the 6 dB range below the applicable limit shall be individually measured using the procedure in clause 5.3.6.2 and compared to the limits given in table 5.

### 5.3.6.2 Identified emissions

Unwanted emissions that are identified during the pre-scan measurements above shall be accurately measured per the procedure below.

The measured values shall be recorded and compared with the limits in table 5. If measurements are conducted at a different distance than specified, then calculations for the equivalent field strength values shall be shown.

The following spectrum analyser settings shall be used:

- a) Centre frequency: Frequency of emission identified during the pre-scan.
- b) Resolution bandwidth: 100 kHz if  $\leq 1$  GHz; 1 MHz if  $> 1$  GHz.
- c) Video bandwidth: 100 kHz if  $\leq 1$  GHz; 1 MHz if  $> 1$  GHz.
- d) Detector mode: Average.
- e) Trace mode: Max hold.

## 5.3.7 Receiver Adjacent Channel Rejection

### 5.3.7.1 Test conditions

See clause 5.1 for the test conditions. These measurements shall only be performed at normal test conditions.

This test shall be performed on all operating carrier frequencies (channels) used by the equipment.

If the equipment can operate with different nominal channel bandwidths, then the smallest channel bandwidth shall be used. The equipment shall be configured in a mode that results in the lowest data rate for this channel bandwidth.

The type of interference used for testing is continuous wave.

### 5.3.7.2 Test Method

Figure 2 describes the test set-up. Both the UUT and the companion device shall be provided by the manufacturer. The manufacturer shall provide a method for generating transmission from the companion device and measuring the Frame Error Rate (FER) at the UUT, while controlling the channel selection, the data rate (MCS), and setting the Beamforming appropriately.

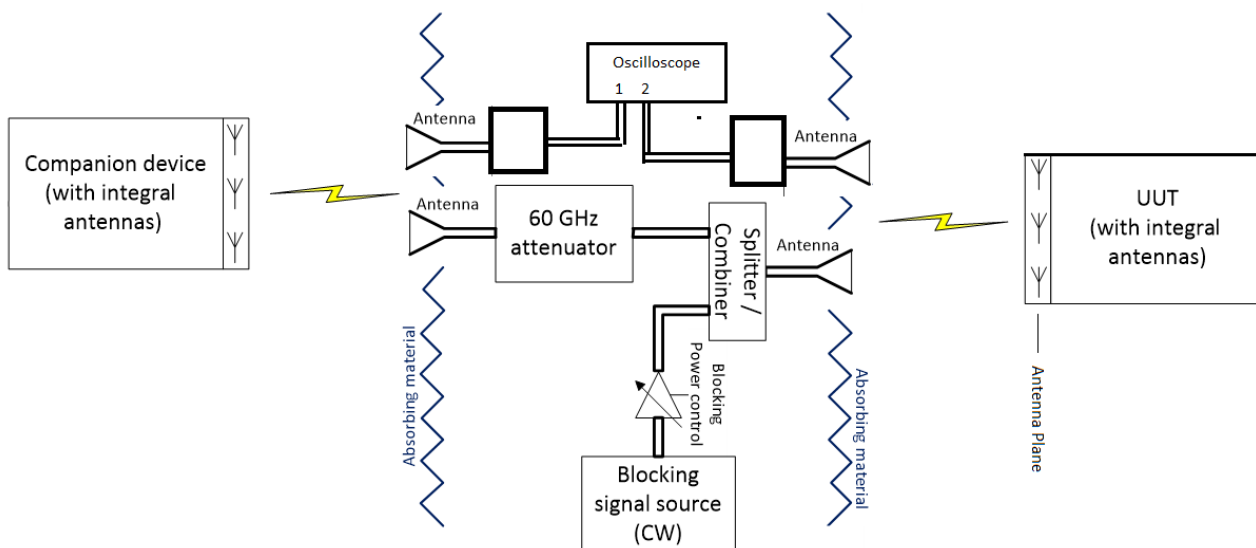

**Figure 2: Test Set-up for verifying the adjacent channel rejection of an equipment**

The Receive Power of the CW Blocking Signal should be calibrated, e.g. by replacing the UUT with a standard reference antenna connected to a Power Meter.

Step 1 to step 4 below define the procedure to verify the Adjacent Channel Rejection requirement as described in clause 4.2.7.



**Step 1:**

- The signal source, the UUT and the companion device are connected using the set-up given by figure 2 although the signal source is switched off at this moment.
- Adjust the level of the wanted signal, by controlling the 60 GHz attenuator to the lowest possible level at which the performance criteria as specified in clause 4.2.7.3 is met. Alternatively, it is possible to reduce Tx Power of companion device.
- The level of the wanted signal measured at the UUT input is the Receiver Sensitivity ( $P_{\min}$ ) for the UUT.

**Step 2:**

- Adjust the received (wanted) signal level at the UUT to be 6 dB above the level  $P_{\min}$ , by reducing the attenuation by 6 dB.
- Configure the signal source for the first frequency and power as in table 6.

**Step 3:**

- It shall be verified and recorded in the test report that the performance criteria as specified in clause 4.2.7.3 is met.

**Step 4:**

- Repeat step 3 for each of the signals (frequency and power) contained in table 6 and for each channel used by the equipment.

## 5.3.8 Adaptivity (medium access protocol)

### 5.3.8.1 Test conditions

These measurements shall only be performed at normal test conditions.

The device shall be configured to operate at its maximum output power level.

Radiated measurement shall be performed in an anechoic chamber or open air test site, see annex C.

### 5.3.8.2 Test method

The principle is to establish a communication between UUT and companion device, and then check the behaviour of UUT in the presence of an interferer.

The UUT may be connected to a companion device during the test. When performing this test of a UUT with directional antenna (such as array antenna system capable of beam-forming), the wanted communication link (between the UUT and the companion device) and the interference signal shall be aligned to the direction corresponding to the UUT's maximum EIRP.

Step 1 to step 5 below define the procedure to verify the efficiency of the mechanism supported by equipment.

**Step 1:**

- The UUT may connect to a companion device during the test. The set-up for radiated testing will include signal generator able to simulate an interferer, spectrum analyser or oscilloscope with two channels, with each channel connected to separate directed antenna, one directed to UUT and the other to the companion device, UUT and the companion device to connect with, but the signal generator does not yet generate any signals at this point in time. The spectrum analyser or oscilloscope is used to monitor the transmissions of the UUT in response to the interference signal.
- When performing testing on a UUT with a directional antenna system (such as array capable of beam-forming), the wanted communication link (between UUT and companion device) and the interference test signals shall be aligned to the direction corresponding to the UUT's maximum EIRP.

- The received signal level (wanted signal from the companion device) at the UUT shall be sufficient to maintain a reliable link for the duration of the test.
- The analyser shall be set as follows:
  - RBW:  $\geq$  nominal channel bandwidth (if the analyser does not support this setting, then 8 MHz minimum shall be used)
  - VBW:  $3 \times$  RBW (if the analyser does not support this setting, the highest available setting shall be used)
  - Detector Mode: RMS
  - Centre Frequency: Equal to the centre frequency of the operating channel
  - Span: 0 Hz
  - Sweep time:  $>$  Channel Occupancy Time/100
  - Trace Mode: Clear/Write
  - Trigger Mode: Video or External

#### Step 2:

- Configure the UUT for normal transmissions with a sufficiently high payload (transmitter activity factor  $> 10\%$ ) to allow demonstration of compliance of the adaptive mechanism on the channel being tested.
- Using procedure defined in clause 5.3.8.3 (for measuring channel/frequency usage), it shall be verified that the UUT complies with the maximum *Channel Occupancy Time* defined in clause 4.2.5.3. It shall also be verified (if necessary by repeating the test) that the measured *Idle Period* is greater or equal to the initial CCA observation time as defined in clause 4.2.5.2.

#### Step 3: Adding the interference signal

- A 100 % duty cycle interference signal is injected on the current operating channel of the UUT. This interference signal shall be a CW signal. The power level of this interference is to be set as defined in clause 4.2.5.3, step 6.

#### Step 4: Verification of reaction to the interference signal

- The analyser shall be used to monitor the transmissions of the UUT and the companion device on the selected operating channel after the interference signal was injected. This may require the analyser sweep to be triggered by the start of the interfering signal.
- Using the procedure defined in clause 5.3.8.3, it shall be verified that:
  - a) The UUT stops transmissions on the current operating channel within a period equal to the maximum *Channel Occupancy Time* defined in clause 4.2.5.3. The UUT is allowed to respond to transmissions of the companion device and the channel occupancy time shall be less than or equal to the maximum channel occupancy time on the current operating channel.
  - b) Apart from transmission of the frames for short control signalling (such as, for example, ACK/NACK signals, beacon frames, other time synchronization frames and frames for beamforming) no frame shall be initiated.
  - c) The time synchronization and beam forming frames transmissions shall be less than or equal to 10 % within an observation period of 100 ms as defined in clause 4.2.6.
  - d) On removal of the interference signal the UUT may start transmissions again on this channel. However, this is not a requirement and, therefore, does not require testing.

#### Step 5:

- Step 2 to step 4 shall be repeated for each of the channels to be tested.

### 5.3.8.3 Generic test procedure for measuring channel/frequency usage

This is a generic test method to evaluate transmissions on the operating channel being investigated. It shall be performed as part of the main procedure in clause 5.3.8.2, steps 2 and 4.

This test procedure shall be as follows:

#### Step 1:

- The analyser shall be set as follows:
  - Centre Frequency: Equal to the centre frequency of the channel being investigated
  - Frequency Span: 0 Hz
  - RBW: Approximately 50 % of the nominal channel bandwidth (if the analyser does not support this setting, 8 MHz minimum shall be used)
  - VBW:  $3 \times$  RBW (if the analyser does not support this setting, the highest available setting shall be used)
  - Detector Mode: RMS
  - Sweep time:  $>$  Channel Occupancy Time
  - Number of sweep points: Minimum 1 point per  $\mu$ s

The time resolution has to be sufficient to meet the maximum measurement uncertainty for the period to be measured. In most cases, 1  $\mu$ s is the shortest period to be measured and thereby defining the time resolution:

- Trace mode: Clear/Write
- Trigger: Video or External

#### Step 2:

- Orientate UUT so that it is pointing at measurement antennas with its higher EIRP as measured during EIRP measurement.
- Position and orientate the companion device antenna in alignment with UUT and measurement antennas.
- Save the trace data of both sides to a file for further analysis by a computing device using an appropriate software application or program.

#### Step 3:

- Oscilloscope channel 1 is directed towards companion device and channel 2 to UUT.
- Identify the data points related to both channels being investigated as referred in figure 3 by applying a threshold.
- Investigate idle periods.
- At the end of each idle period, investigate the transmissions initiating device.
- For the UUT initiating transmissions, calculate the percentage of occupied time per period of 100 ms.
- Repeat step 3 for all idle periods within the measurement window.

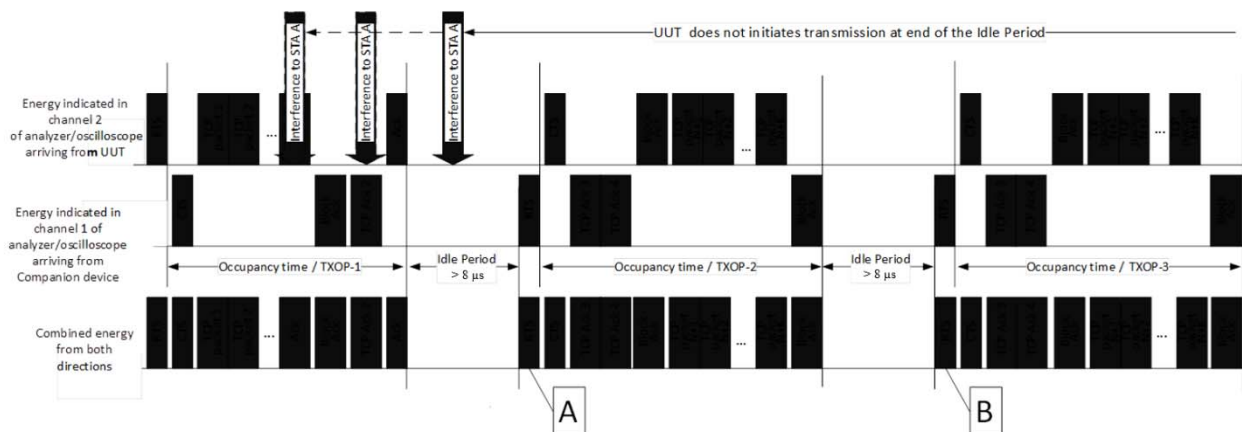

Figure 3: Channel 1/2 chronogram

## 5.3.9 Transmitter unwanted emissions in the out-of-band domain

### 5.3.9.1 Test conditions

These measurements need only to be performed at normal test conditions.

The device shall be configured to operate at its maximum output power level.

Radiated measurement shall be performed in an anechoic chamber or open air test site, see annex C.

### 5.3.9.2 Test method

The transmitter unwanted emissions in the out-of-band domain shall be measured using applicable measurement procedures in annex D for conformance with the requirements in clause 4.2.8.

The transmitter unwanted emissions in the out-of-band domain shall be determined using a spectrum analyser of adequate bandwidth for the type of modulation being used in combination with a RF power meter.

For the purpose of this test, the minimum transmitter on time shall be 10  $\mu$ s. For equipment where the transmitter on time is less than 10  $\mu$ s, the method of measurement shall be documented in the test report.

The test procedure shall be as follows:

#### Step 1:

The spectrum analyser shall use the following settings:

- a) Start/Stop frequencies: As needed per figure 1.
- b) Resolution bandwidth: 1 MHz.
- c) Video bandwidth: 3 MHz.
- d) Sweep time: 1 minute.
- e) Detector: RMS Average, Sample, or Average (excepting Video Average).
- f) Trace mode: Max hold.

#### Step 2:

When the trace is complete, capture the trace, for example, using the "View" option on the spectrum analyser.

Find the peak value of the trace and place the analyser marker on this peak. The value from the above corrected by the duty cycle  $\times$ , according to the formula in clause 5.3.3, step 4 shall be recorded in the test report.

## 5.3.10 Occupied Channel Bandwidth

### 5.3.10.1 Test conditions

These measurements need to be performed at normal and extreme test conditions.

The device shall be configured to operate at its maximum output power level. If the device can operate with different nominal channel bandwidths, then for each nominal channel bandwidth the mode of transmission with the largest necessary bandwidth shall be used for this test.

### 5.3.10.2 Test method

The Occupied Channel Bandwidth shall be measured using applicable measurement procedures in annex D for conformance with the requirements in clause 4.2.10.

The Occupied Channel Bandwidth shall be determined using a spectrum analyser of adequate bandwidth for the type of modulation being used in combination with a RF power meter.

For the purpose of this test, the minimum transmitter on time shall be 10  $\mu$ s. For equipment where the transmitter on time is less than 10  $\mu$ s, the method of measurement shall be documented in the test report.

The test procedure shall be as follows:

#### Step 1:

The spectrum analyser shall use the following settings:

- a) Start/Stop frequencies: As needed per figure 1.
- b) Resolution bandwidth: 1 MHz.
- c) Video bandwidth: 3 MHz.
- d) Sweep time: 1 minute.
- e) Detector: RMS Average, Sample, or Average (excepting Video Average).
- f) Trace mode: Max hold.

#### Step 2:

When the trace is complete, capture the trace, for example, using the "View" option on the spectrum analyser.

Use the 99 % bandwidth function of the spectrum analyser to measure the Occupied Channel Bandwidth. This value shall be recorded.

## 5.3.11 Receiver sensitivity level

### 5.3.11.1 Test conditions

See clause 5.1 for the test conditions. These measurements shall only be performed at normal test conditions.

This test shall be performed on all operating carrier frequencies (channels) used by the equipment.

If the equipment can operate with different nominal channel bandwidths, then the smallest channel bandwidth shall be used. The equipment shall be configured in a mode that results in the lowest data rate for this channel bandwidth.

### 5.3.11.2 Test method

Figure 2 of clause 5.3.7.2 describes the test set-up. Both the UUT and the companion device shall be provided by the manufacturer. The manufacturer shall provide a method for generating transmission from the companion device and measuring the FER at the UUT, while controlling the channel selection, the data rate (MCS), and setting the Beamforming appropriately.

Step 1 and step 2 below define the procedure to verify the Receiver Sensitivity requirement as described in clause 4.2.11.

**Step 1:**

- The signal source, the UUT and the companion device are connected using the set-up given by figure 2 with the signal source switched off.
- Adjust the level of the wanted signal, by controlling the 60 GHz attenuator to the lowest possible level at which the performance criteria as specified in clause 4.2.7.3 is met. Alternatively, it is possible to reduce Tx Power of companion device.
- The level of the wanted signal measured at the UUT antenna plane is the Receiver Sensitivity ( $P_{\min}$ ) for the UUT.

**Step 2:**

- Repeat step 1 for each channel used by the equipment.

The results obtained shall be compared to the limits in clause 4.2.11.3 in order to show compliance.

## Annex A (informative): Relationship between the present document and the essential requirements of Directive 2014/53/EU

The present document has been prepared under the Commission's standardisation request C(2015) 5376 final [i.2] to provide one voluntary means of conforming to the essential requirements of Directive 2014/53/EU on the harmonisation of the laws of the Member States relating to the making available on the market of radio equipment and repealing Directive 1999/5/EC [i.6].

Once the present document is cited in the Official Journal of the European Union under that Directive, compliance with the normative clauses of the present document given in table A.1 confers, within the limits of the scope of the present document, a presumption of conformity with the corresponding essential requirements of that Directive, and associated EFTA regulations.

**Table A.1: Relationship between the present document and the essential requirements of Directive 2014/53/EU**

Harmonised Standard ETSI EN 302 567					
Requirement				Requirement Conditionality	
No	Description	Essential requirements of Directive	Clause(s) of the present document	U/C	Condition
1	Spectral power density	3.2	4.2.1	U	
2	RF output power	3.2	4.2.2	U	
3	Transmitter unwanted emissions in the spurious domain	3.2	4.2.3	U	
4	Receiver unwanted emissions	3.2	4.2.4	U	
5	Adaptivity (medium access protocol)	3.2	4.2.5	U	
6	Short Control Signalling Transmissions	3.2	4.2.6	U	
7	Receiver Adjacent Channel Rejection	3.2	4.2.7	U	
8	Transmitter unwanted emissions in the out-of-band domain	3.2	4.2.8	U	
9	Occupied Channel Bandwidth	3.2	4.2.10	U	
10	Receiver Sensitivity level	3.2	4.2.11	U	

### Key to columns:

#### Requirement:

**No** A unique identifier for one row of the table which may be used to identify a requirement.

**Description** A textual reference to the requirement.

#### Essential requirements of Directive

Identification of article(s) defining the requirement in the Directive.

#### Clause(s) of the present document

Identification of clause(s) defining the requirement in the present document unless another document is referenced explicitly.

**Requirement Conditionality:**

<b>U/C</b>	Indicates whether the requirement is unconditionally applicable (U) or is conditional upon the manufacturer's claimed functionality of the equipment (C).
<b>Condition</b>	Explains the conditions when the requirement is or is not applicable for a requirement which is classified "conditional".

Presumption of conformity stays valid only as long as a reference to the present document is maintained in the list published in the Official Journal of the European Union. Users of the present document should consult frequently the latest list published in the Official Journal of the European Union.

Other Union legislation may be applicable to the product(s) falling within the scope of the present document.



---

## Annex B (informative): Maximum Measurement Uncertainty

The measurements described in the present document are based on the following assumptions:

- the measured value related to the corresponding limit is used to decide whether an equipment meets the requirements of the present document;
- the value of the measurement uncertainty for the measurement of each parameter is included in the test report.

Table B.1 shows the recommended values for the maximum measurement uncertainty figures.

**Table B.1: Maximum measurement uncertainty**

<b>Parameter</b>	<b>Uncertainty</b>
Radio Frequency	$\pm 1$ ppm
RF power, radiated	$\pm 6$ dB
Spurious emissions, radiated	$\pm 6$ dB
Humidity	$\pm 5$ %
Temperature	$\pm 1$ °C
Time	$\pm 10$ %

## Annex C (normative): Test sites and arrangements for radiated measurements

### C.1 Test sites

#### C.1.1 Open air test sites

The term "open air" should be understood from an electromagnetic point of view. Such a test site may be really in open air or alternatively with walls and ceiling transparent to the radio waves at the frequencies considered.

An open air test site may be used to perform the measurements using the radiated measurement methods described in clause 5.3. Absolute or relative measurements may be performed on transmitters or on receivers; absolute measurements of field strength require a calibration of the test site.

A measuring distance of at least 3 m shall be used for measurements at frequencies up to 1 GHz. For frequencies above 1 GHz, any suitable measuring distance may be used. The equipment size (excluding the antenna) shall be less than 20 % of the measuring distance. The height of the equipment or of the substitution antenna shall be 1,5 m; the height of the test antenna (transmit or receive) shall vary between 1 m and 4 m.

Sufficient precautions shall be taken to ensure that reflections from extraneous objects adjacent to the site do not degrade the measurement results, in particular:

- no extraneous conducting objects having any dimension in excess of a quarter wavelength of the highest frequency tested shall be in the immediate vicinity of the site;
- all cables shall be as short as possible; as much of the cables as possible shall be on the ground plane or preferably below; and the low impedance cables shall be screened.

The general measurement arrangement is shown in figure C.1.

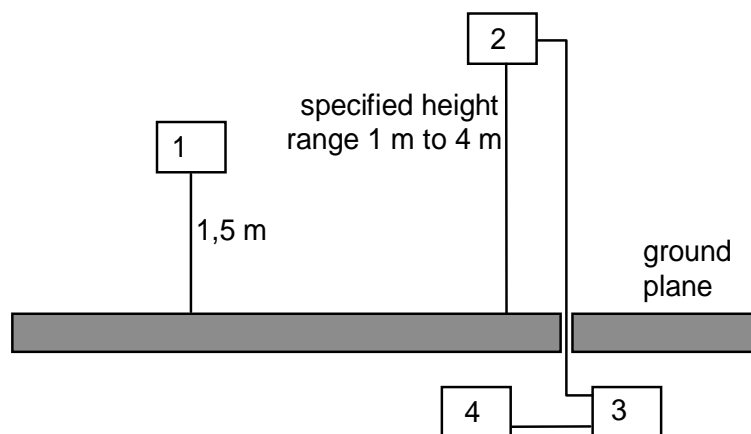

- 1) Equipment under test.
- 2) Test antenna.
- 3) High pass filter (as required).
- 4) Spectrum analyser or measuring receiver.

**Figure C.1: Measuring arrangement**

## C.1.2 Anechoic chamber

### C.1.2.1 General

An anechoic chamber is a well shielded chamber covered inside with radio frequency absorbing material and simulating a free space environment. It is an alternative site on which to perform the measurements using the radiated measurement methods described in clause 5.3. Absolute or relative measurements may be performed on transmitters or on receivers. Absolute measurements of field strength require a calibration of the anechoic chamber. The test antenna, equipment under test and substitution antenna are used in a way similar to that at the open air test site, but are all located at the same fixed height above the floor.

### C.1.2.2 Description

An anechoic chamber should meet the requirements for shielding loss and wall return loss as shown in figure C.2. Figure C.3 shows an example of the construction of an anechoic chamber having a base area of 5 m by 10 m and a height of 5 m. The ceiling and walls are coated with pyramidally formed absorbers approximately 1 m high. The base is covered with special absorbers which form the floor. The available internal dimensions of the chamber are 3 m × 8 m × 3 m, so that a maximum measuring distance of 5 m in the middle axis of this chamber is available. The floor absorbers reject floor reflections so that the antenna height need not be changed. Anechoic chambers of other dimensions may be used. Alternatively, an anechoic chamber having a base area of 2,5 m × 3 m and a height of 5 m may also be used.

### C.1.2.3 Influence of parasitic reflections

For free-space propagation in the far field, the relationship of the field strength  $E$  and the distance  $R$  is given by  $E = E_0 \times (R_0 / R)$ , where  $E_0$  is the reference field strength and  $R_0$  is the reference distance. This relationship allows relative measurements to be made as all constants are eliminated within the ratio and neither cable attenuation nor antenna mismatch or antenna dimensions are of importance.

If the logarithm of the foregoing equation is used, the deviation from the ideal curve may be easily seen because the ideal correlation of field strength and distance appears as a straight line. The deviations occurring in practice are then clearly visible. This indirect method shows quickly and easily any disturbances due to reflections and is far less difficult than the direct measurement of reflection attenuation.

With an anechoic chamber of the dimensions given above at low frequencies below 100 MHz there are no far field conditions, but the wall reflections are stronger, so that careful calibration is necessary. In the medium frequency range from 100 MHz to 1 GHz the dependence of the field strength to the distance meets the expectations very well. Above 1 GHz, because more reflections will occur, the dependence of the field strength to the distance will not correlate so closely.

### C.1.2.4 Calibration and mode of use

The calibration and mode of use is the same as for an open air test site, the only difference being that the test antenna does not need to be raised and lowered whilst searching for a maximum, which simplifies the method of measurement.

Below 142 GHz the shielding and return loss shall be as described in figure C.2.

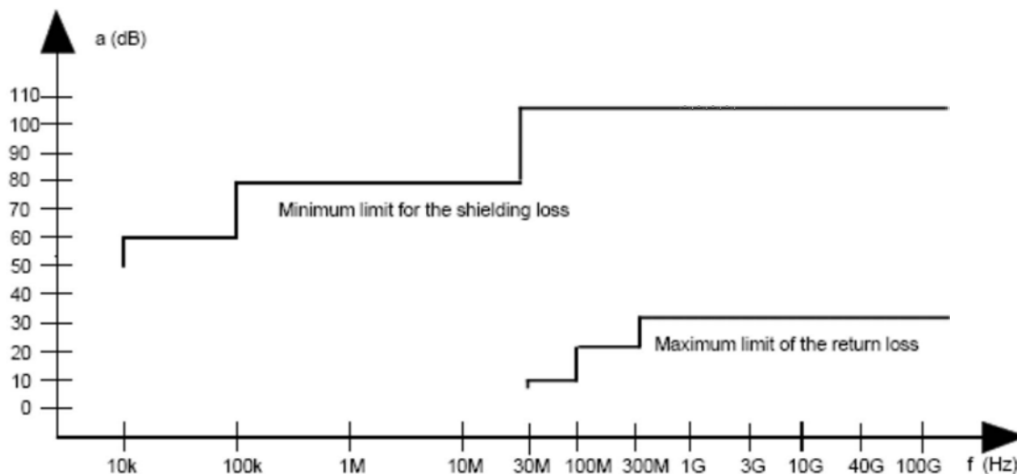

Figure C.2: Specification for shielding and reflections

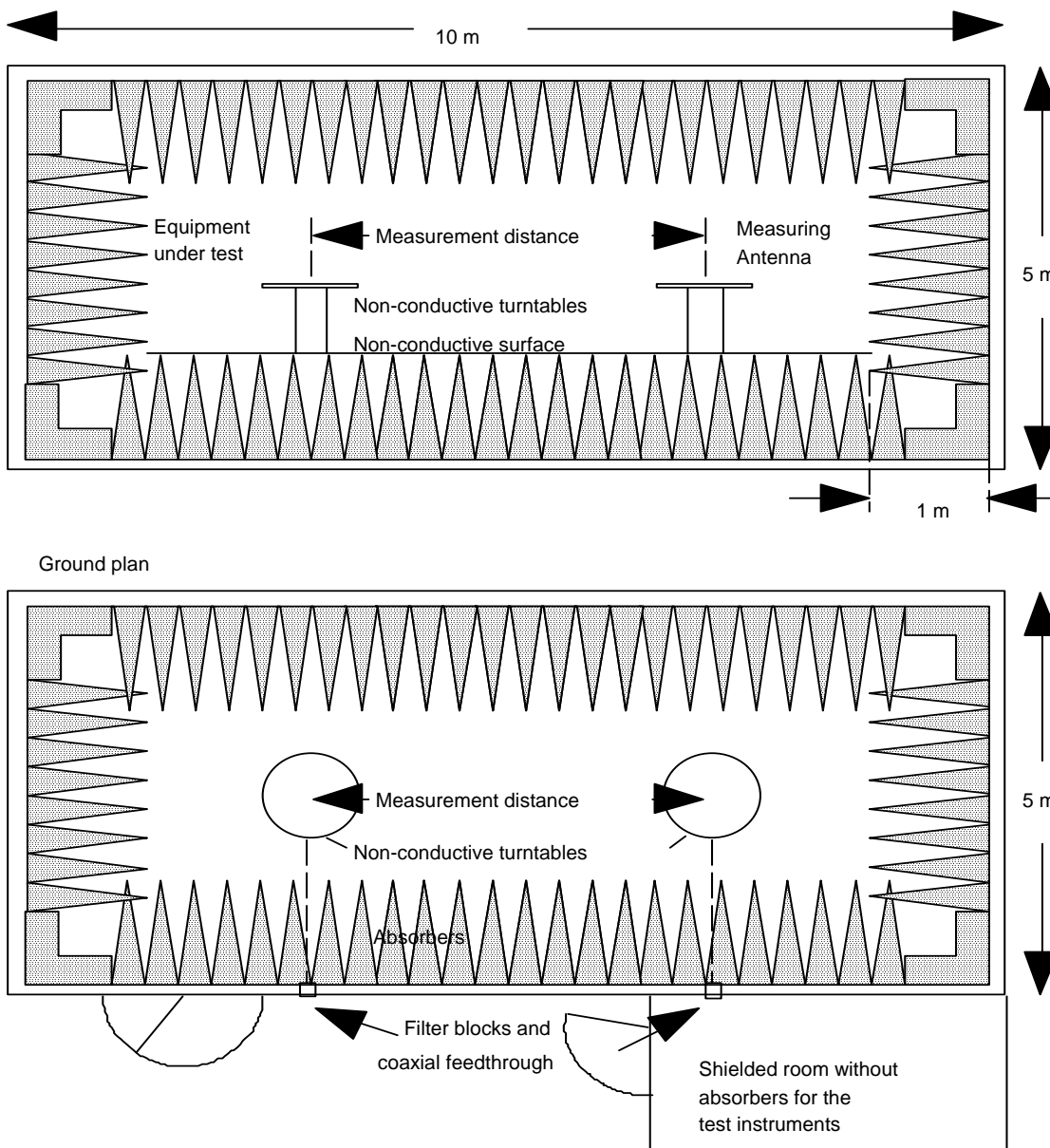

Figure C.3: Anechoic shielded chamber for simulated free space measurements

---

## C.2 Test antenna

When the test site is used for radiated measurements the test antenna shall be used to detect the field from both the test sample and the substitution antenna. When the test site is used for the measurement of receiver characteristics the antenna shall be used as a transmitting antenna. This antenna shall be mounted on a support capable of allowing the antenna to be used in either horizontal or vertical polarization and for the height of its centre above the ground to be varied over the specified range. Preferably test antennae with pronounced directivity should be used. The size of the test antenna along the measurement axis shall not exceed 20 % of the measuring distance. The antenna shall include any necessary up/down conversion to an intermediate frequency for practical signal transport to/from related test equipment.

---

## C.3 Substitution antenna

The substitution antenna shall be used to replace the equipment under test in substitution measurements. For measurements below 1 GHz the substitution antenna shall be a half wavelength dipole resonant at the frequency under consideration, or a shortened dipole, calibrated to the half wavelength dipole. For measurements between 1 GHz and 4 GHz either a half wavelength dipole or a horn radiator may be used. For measurements above 4 GHz a horn radiator shall be used. The centre of this antenna shall coincide with the reference point of the test sample it has replaced. This reference point shall be the volume centre of the sample when its antenna is mounted inside the cabinet, or the point where an outside antenna is connected to the cabinet.

The distance between the lower extremity of the dipole and the ground shall be at least 30 cm.

NOTE: The gain of a horn antenna is generally expressed relative to an isotropic radiator.

## Annex D (normative): General description of measurement

### D.1 Radiated measurements

Radiated measurements shall be performed with the aid of a test antenna and measurement instruments as described in annex C. The test antenna and measurement instrument shall be calibrated according to the procedure defined in this annex. The equipment to be measured and the test antenna shall be oriented to obtain the maximum emitted power level. This position shall be recorded in the measurement report. The frequency range shall be measured in this position.

Preferably, radiated measurements shall be performed in an anechoic chamber. For other test sites corrections may be needed (see annex C). The following test procedure applies:

- a) A test site which fulfils the requirements of the specified frequency range of this measurement shall be used. The test antenna shall be oriented initially for vertical polarization unless otherwise stated and the transmitter under test shall be placed on the support in its standard position (clause C.1.1) and switched on.
- b) For average power measurements a non-selective voltmeter or wideband spectrum analyser shall be used. For other measurements a spectrum analyser or selective voltmeter shall be used and tuned to the measurement frequency.

In either case a) or case b), the test antenna shall be raised or lowered, if necessary, through the specified height range until the maximum signal level is detected on the spectrum analyser or selective voltmeter.

The test antenna need not be raised or lowered if the measurement is carried out on a test site according to clause C.1.2.

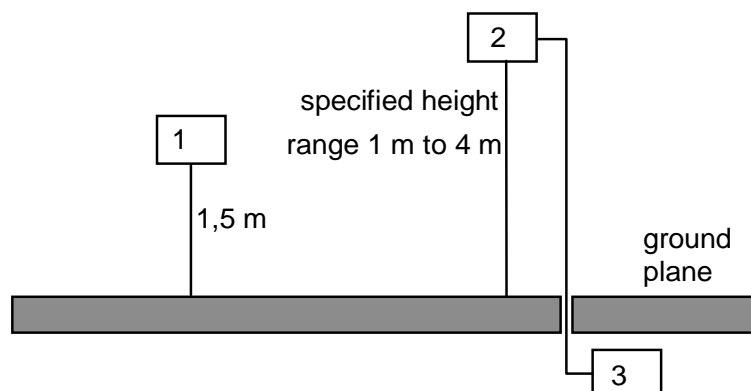

- 1) Equipment under test.
- 2) Test antenna.
- 3) Spectrum analyser or measuring receiver.

**Figure D.1: Measurement arrangement No.1**

- c) The transmitter shall be rotated through 360° about a vertical axis until a higher maximum signal is received.
- d) The test antenna shall be raised or lowered again, if necessary, through the specified height range until a maximum is obtained. This level shall be recorded. This maximum may be a lower value than the value obtainable at heights outside the specified limits. The test antenna need not be raised or lowered if the measurement is carried out on a test site according to clause C.1.2. This measurement shall be repeated for horizontal polarization.

## D.2 Substitution measurement

The actual signal generated by the measured equipment may be determined by means of a substitution measurement in which a known signal source replaces the device to be measured, see figure D.2.

Preferably, this method of measurement shall be used in an anechoic chamber. For other test sites corrections may be needed, see annex C.

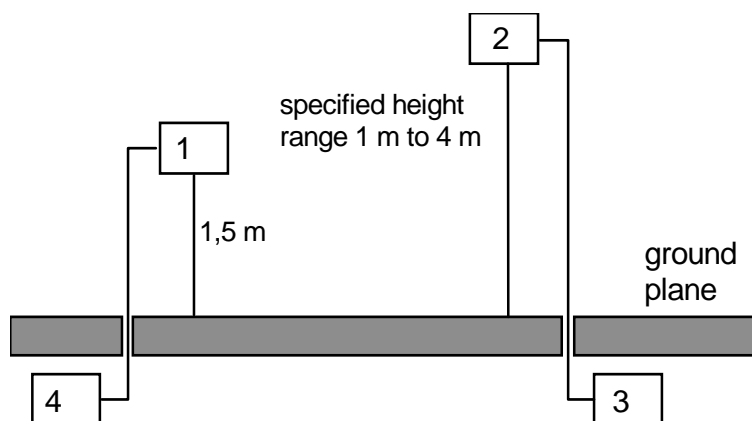

- 1) Substitution antenna.
- 2) Test antenna.
- 3) Spectrum analyser or selective voltmeter.
- 4) Signal generator.

**Figure D.2: Measurement arrangement No.2**

- a) Using measurement arrangement No.2, the substitution antenna shall replace the transmitter antenna in the same position and in vertical polarization. The frequency of the signal generator shall be adjusted to the measurement frequency. The test antenna shall be raised or lowered, if necessary, to ensure that the maximum signal is still received. The input signal to the substitution antenna shall be adjusted in level until an equal or a known related level to that detected from the transmitter is obtained in the test receiver:
  - the test antenna need not be raised or lowered if the measurement is carried out on a test site according to clause C.1.2;
  - the radiated power is equal to the power supplied by the signal generator, increased by the known relationship if necessary and after corrections due to the gain of the substitution antenna and the cable loss between the signal generator and the substitution antenna.
- b) This measurement shall be repeated with horizontal polarization.

For test sites with a fixed setup of the measurement antenna(s) and a reproducible positioning of the UUT, correction values from a verified site calibration can be used alternatively.

---

## Annex E (informative): Bibliography

- Electromagnetic Compatibility (EMC) Directive 2014/30/EU of the European Parliament published in the Official Journal of the European Union L 96/79, 29 March 2014 and repealing Directive 2004/108/EC as from 20 April 2016.
- Low Voltage Directive 2014/35/EU of the European Parliament and of the Council of 26 February 2014 and repealing Directive 2006/95/EC as of 20 April 2016.
- ETSI EG 203 336: "Electromagnetic compatibility and Radio spectrum Matters (ERM); Guide for the selection of technical parameters for the production of Harmonised Standards covering article 3.1(b) and article 3.2 of Directive 2014/53/EU".



## Annex F (informative): Change History

Version	Information about changes
2.1.1	First published version covering Directive 2014/53/EU. Major changes are: <ul style="list-style-type: none"> <li>• Clause 4.2.5 on Adaptivity (medium access protocol) added.</li> <li>• Clause 4.2.7 on Adjacent Channel Rejection added.</li> <li>• Clause 4.2.8 on Transmitter Unwanted Emissions in the Out-Of-Band Domain added.</li> <li>• Clause 4.2.9 on Geo-Location Capability added.</li> <li>• Clause 4.2.10 on Occupied Channel Bandwidth added.</li> </ul>
2.2.1	Major changes are: <ul style="list-style-type: none"> <li>• Band extension up to 71 GHz.</li> <li>• Clause 4.2.3 on Transmitter Unwanted Emission in the Spurious Domain modified.</li> <li>• Clause 4.2.6 on Short Control Signaling Transmissions added.</li> <li>• Clause 4.2.7 on Receiver Adjacent Channel Rejection modified.</li> <li>• Clause 4.2.8 on Transmitter Unwanted Emissions in the Out-Of-Band Domain modified.</li> <li>• Clause 4.2.9 on Geo Location Capability removed.</li> <li>• Clause 4.2.11 on Receiver sensitivity level added.</li> </ul>

---

# History

<b>Document history</b>			
V1.1.1	March 2009	Publication	
V1.2.1	January 2012	Publication	
V2.1.1	July 2017	Publication	
V2.2.0	December 2020	EN Approval Procedure	AP 20210318: 2020-12-18 to 2021-03-18
V2.2.1	May 2021	Vote	V 20210705: 2021-05-06 to 2021-07-05