



**Broadband Radio Access Networks (BRAN);
60 GHz Multiple-Gigabit WAS/RLAN Systems;
Harmonized EN covering the essential requirements
of article 3.2 of the R&TTE Directive**

Reference

REN/BRAN-0060008

Keywords

access, broadband, LAN, radio, SRD, testing

ETSI

650 Route des Lucioles
F-06921 Sophia Antipolis Cedex - FRANCE

Tel.: +33 4 92 94 42 00 Fax: +33 4 93 65 47 16

Siret N° 348 623 562 00017 - NAF 742 C
Association à but non lucratif enregistrée à la
Sous-Préfecture de Grasse (06) N° 7803/88

Important notice

Individual copies of the present document can be downloaded from:

<http://www.etsi.org>

The present document may be made available in more than one electronic version or in print. In any case of existing or perceived difference in contents between such versions, the reference version is the Portable Document Format (PDF). In case of dispute, the reference shall be the printing on ETSI printers of the PDF version kept on a specific network drive within ETSI Secretariat.

Users of the present document should be aware that the document may be subject to revision or change of status. Information on the current status of this and other ETSI documents is available at

<http://portal.etsi.org/tb/status/status.asp>

If you find errors in the present document, please send your comment to one of the following services:

http://portal.etsi.org/chaicor/ETSI_support.asp

Copyright Notification

No part may be reproduced except as authorized by written permission.
The copyright and the foregoing restriction extend to reproduction in all media.

© European Telecommunications Standards Institute 2011.
All rights reserved.

DECT™, PLUGTESTS™, UMTS™ and the ETSI logo are Trade Marks of ETSI registered for the benefit of its Members.
3GPP™ and LTE™ are Trade Marks of ETSI registered for the benefit of its Members and
of the 3GPP Organizational Partners.
GSM® and the GSM logo are Trade Marks registered and owned by the GSM Association.

Contents

Intellectual Property Rights	5
Foreword.....	5
Introduction	5
1 Scope	6
2 References	6
2.1 Normative references	7
2.2 Informative references.....	7
3 Definitions, symbols and abbreviations	7
3.1 Definitions	7
3.2 Symbols.....	8
3.3 Abbreviations	8
4 Technical requirements specifications	9
4.1 Environmental profile.....	9
4.2 Conformance requirements	9
4.2.1 Spectral power density.....	9
4.2.1.1 Definition	9
4.2.1.2 Limit.....	9
4.2.1.3 Conformance.....	9
4.2.2 RF output power	9
4.2.2.1 Definition	9
4.2.2.2 Limit.....	9
4.2.2.3 Conformance.....	10
4.2.3 Transmitter unwanted emissions.....	10
4.2.3.1 Definition	10
4.2.3.2 Limit.....	10
4.2.3.3 Conformance.....	10
4.2.4 Receiver unwanted emissions	10
4.2.4.1 Definition	10
4.2.4.2 Limit.....	10
4.2.4.3 Conformance.....	11
4.2.5 Medium access protocol	11
4.2.5.1 Definition	11
4.2.5.2 Requirement	11
4.2.6 Integral antenna	11
4.2.6.1 Definition	11
4.2.6.2 Requirement	11
5 Testing for compliance with technical requirements.....	11
5.1 Environmental conditions for testing	11
5.2 Interpretation of the measurement results	11
5.3 Essential radio test suites.....	12
5.3.1 Product Information.....	12
5.3.2 Test modulation, frequency and configuration	12
5.3.3 Spectral power density.....	13
5.3.4 RF output power	14
5.3.5 Transmitter unwanted emissions.....	15
5.3.5.1 Pre-scan	15
5.3.5.2 Identified emissions	16
5.3.6 Receiver unwanted emissions	16
5.3.6.1 Pre-scan.....	17
5.3.6.2 Identified emissions	17
Annex A (normative): HS Requirements and conformance Test specifications Table (HS-RTT).....	18

Annex B (informative):	The EN title in the official languages	20
Annex C (normative):	Test sites and arrangements for radiated measurements.....	21
C.1	Test sites	21
C.1.1	Open air test sites	21
C.1.2	Anechoic chamber	22
C.1.2.1	General.....	22
C.1.2.2	Description.....	22
C.1.2.3	Influence of parasitic reflections	22
C.1.2.4	Calibration and mode of use	23
C.2	Test antenna.....	24
C.3	Substitution antenna	25
Annex D (normative):	General description of measurement	26
D.1	Radiated measurements	26
D.2	Substitution measurement	27
Annex E (informative):	Bibliography.....	28
History		29

Intellectual Property Rights

IPRs essential or potentially essential to the present document may have been declared to ETSI. The information pertaining to these essential IPRs, if any, is publicly available for **ETSI members and non-members**, and can be found in ETSI SR 000 314: "*Intellectual Property Rights (IPRs); Essential, or potentially Essential, IPRs notified to ETSI in respect of ETSI standards*", which is available from the ETSI Secretariat. Latest updates are available on the ETSI Web server (<http://ipr.etsi.org>).

Pursuant to the ETSI IPR Policy, no investigation, including IPR searches, has been carried out by ETSI. No guarantee can be given as to the existence of other IPRs not referenced in ETSI SR 000 314 (or the updates on the ETSI Web server) which are, or may be, or may become, essential to the present document.

Foreword

This final draft Harmonized European Standard (EN) has been produced by ETSI Technical Committee Broadband Radio Access Networks (BRAN), and is now submitted for the Vote phase of the ETSI standards Two-step Approval Procedure.

The present document has been produced by ETSI in response to a mandate from the European Commission issued under Council Directive 98/34/EC [i.2] (as amended) laying down a procedure for the provision of information in the field of technical standards and regulations.

The title and reference to the present document are intended to be included in the publication in the Official Journal of the European Union of titles and references of Harmonized Standard under the Directive 1999/5/EC [2].

See article 5.1 of Directive 1999/5/EC [2] for information on presumption of conformity and Harmonised Standards or parts thereof the references of which have been published in the Official Journal of the European Union.

The requirements relevant to Directive 1999/5/EC [2] are summarised in annex A.

Proposed national transposition dates	
Date of latest announcement of this EN (doa):	3 months after ETSI publication
Date of latest publication of new National Standard or endorsement of this EN (dop/e):	6 months after doa
Date of withdrawal of any conflicting National Standard (dow):	18 months after doa

Introduction

The present document is part of a set of standards developed by ETSI and is designed to fit in a modular structure to cover all radio and telecommunications terminal equipment within the scope of the R&TTE Directive [2]. The modular structure is shown in EG 201 399 [i.6].

1 Scope

The present document applies to radio equipment types for wireless access systems (WAS)/Radio Local Area Networks (RLAN) operating at multiple-gigabit data rates in the 60 GHz frequency range. These applications may also be referred to as Wireless Personal Area Network (WPAN) or Wireless Local Area Network (WLAN) systems and are intended for licence-exempt short-range devices. Economic benefits of this usage apply to a variety of markets including communications, computing, and consumer electronics by enabling the transfer of large amounts of information in a short amount of time (for example, from a kiosk to a mobile phone) or the continuous streaming of uncompressed data (for example, the external video interfaces of a computer or high definition disc player).

These networks operate over a short range with very wideband communications using a variety of directional medium and high gain antennas to enable a high degree of spectrum reuse, and may use a flexible bandwidth scheme under which they normally operate in a wideband mode, and periodically reduce their bandwidth (e.g. for antenna training and other activities).

The spectrum usage conditions for this equipment are set in Commission Decision 2006/771/EC [i.7] as amended by 2010/368/EU [i.8] and ERC Recommendation 70-03, annex 3 [i.5].

The technical characteristics of these applications are further described in TR 102 555 [i.1]. Equipment in this frequency range intended for outdoor Fixed Local Area Network Extension (FLANE) or Fixed Point-to-Point applications are not in the scope of the present document.

The present document is intended to support specifications such as those addressed in IEEE 802.15.3c [i.3], ECMA TC48 [i.4] and other international bodies.

These radio equipment types are capable of operating in all or any part of the frequency bands given in table 1.

Table 1: Radiocommunications service frequency bands

Radiocommunications service frequency bands	
Transmit	57 GHz to 66 GHz
Receive	57 GHz to 66 GHz

The present document is intended to cover the provisions of Directive 1999/5/EC [2] (R&TTE Directive), article 3.2, which states that "..... radio equipment shall be so constructed that it effectively uses the spectrum allocated to terrestrial/space radio communications and orbital resources so as to avoid harmful interference".

In addition to the present document, other ENs that specify technical requirements in respect of essential requirements under other parts of article 3 of the R&TTE Directive [2] may apply to equipment within the scope of the present document.

NOTE: A list of such ENs is included on the web site <http://www.newapproach.org>.

2 References

References are either specific (identified by date of publication and/or edition number or version number) or non-specific. For specific references, only the cited version applies. For non-specific references, the latest version of the referenced document (including any amendments) applies.

Referenced documents which are not found to be publicly available in the expected location might be found at <http://docbox.etsi.org/Reference>.

NOTE: While any hyperlinks included in this clause were valid at the time of publication, ETSI cannot guarantee their long term validity.

2.1 Normative references

The following referenced documents are necessary for the application of the present document.

- [1] ERC Recommendation 74-01 (2011): "Unwanted Emissions in the Spurious Domain".
- [2] Directive 1999/5/EC of the European Parliament and of the Council of 9 March 1999 on radio equipment and telecommunications terminal equipment and the mutual recognition of their conformity (R&TTE Directive).
- [3] ETSI TR 100 028 (V1.4.1) - (all parts): "Electromagnetic compatibility and Radio spectrum Matters (ERM); Uncertainties in the measurement of mobile radio equipment characteristics".
- [4] ITU-R Recommendation SM.1539-1 (2002): "Variation of the boundary between the out-of-band and spurious domains required for the application of Recommendations ITU-R SM.1541 and ITU-R SM.329".

2.2 Informative references

The following referenced documents are not necessary for the application of the present document but they assist the user with regard to a particular subject area.

- [i.1] ETSI TR 102 555: "Electromagnetic compatibility and Radio spectrum Matters (ERM); Technical characteristics of multiple gigabit wireless systems in the 60 GHz range System Reference Document".
- [i.2] Directive 98/34/EC of the European Parliament and of the Council of 22 June 1998 laying down a procedure for the provision of information in the field of technical standards and regulations.
- [i.3] IEEE 802.15.3c: "IEEE Standard for Information Technology - Specific Requirements - Part 15: Wireless Personal Area Networks with Millimeter Wave Alternative Physical Task Group 3c (TG3c)".
- [i.4] ECMA TC48, High Rate Short Range Wireless Communications.
- [i.5] ERC Recommendation 70-03 (Tromsø 1997 and subsequent amendments): "Related to the Use of Short Range Devices (SRD)".
- [i.6] ETSI EG 201 399: "Electromagnetic compatibility and Radio spectrum Matters (ERM); A guide to the production of Harmonized Standards for application under the R&TTE Directive".
- [i.7] Commission Decision 2006/771/EC of 9 November 2006 on harmonisation of the radio spectrum for use by short-range devices.
- [i.8] Commission Decision 2010/368/EU of 30 June 2010 amending Decision 2006/771/EC on harmonisation of the radio spectrum for use by short-range devices.

3 Definitions, symbols and abbreviations

3.1 Definitions

For the purposes of the present document, the terms and definitions given in Directive 1999/5/EC [2] and the following apply:

60 GHz range or 60 GHz band: one of the variously permitted frequencies of operation, typically from 57 GHz to 66 GHz

activity factor: percentage over any one minute time period when equipment is operating under a given set of conditions

channel separation: minimum separation (in MHz) between the centre frequencies of two adjacent channels in the channel plan of the radio equipment

environmental profile: range of environmental conditions under which equipment within the scope of the present document is required to comply with the provisions of the present document

integral antenna: antenna which is declared to be part of the radio equipment by the supplier

NOTE 1: In some cases, it may not be possible to remove an integral antenna or expose an antenna connector without changing the output characteristics of the radio equipment.

NOTE 2: Even with an integral antenna, it might still be possible to separate the antenna from the equipment using a special tool.

mean power: when applied to a modulated signal, this is the power (transmitted or received) in a bandwidth

occupied bandwidth: frequency bandwidth of the signal power at the -6 dBc points

smart antenna systems: equipment that combines multiple transmit and/or receive antenna elements with a signal processing function to increase its radiation and/or reception capabilities

NOTE: This includes techniques such as spatial multiplexing, beam forming, cyclic delay diversity, etc.

3.2 Symbols

For the purposes of the present document, the following symbols apply:

dBc	spectral density relative to the maximum spectral power density of the transmitted signal
dBm	decibel relative to one milliwatt
dBr	decibel relative to a given maximum power level
GHz	thousand millions of cycles
kHz	thousands of cycles
µs	millionths of seconds

3.3 Abbreviations

For the purposes of the present document, the following abbreviations apply:

ChS	Channel Separation
EIRP	Equivalent Isotropically Radiated Power
FLANE	Fixed Local Area Network Extension
OBw	Occupied Bandwidth
PDL	spectral Power Density Limit
RBw	Resolution Bandwidth
RF	Radio Frequency
RLAN	Radio Local Area Network
R&TTE	Radio and Telecommunications Terminal Equipment
UUT	Unit Under Test
WAS	Wireless Access System
WLAN	Wireless Local Area Network
WPAN	Wireless Personal Area Network

4 Technical requirements specifications

4.1 Environmental profile

The technical requirements of the present document apply under the environmental profile for operation of the equipment, which shall be declared by the supplier. The equipment shall comply with all the technical requirements of the present document at all times when operating within the boundary limits of the declared operational environmental profile.

4.2 Conformance requirements

4.2.1 Spectral power density

4.2.1.1 Definition

The spectral power density is the mean Equivalent Isotropically Radiated Power (EIRP) density in Watts per Hertz during a transmission burst.

4.2.1.2 Limit

The maximum spectral power density is applicable to the system as a whole when operated at the highest stated power level. For a smart antenna system, the limit applies to the configuration that results in the highest EIRP.

The maximum spectral power density shall be as indicated in table 2.

Table 2: Spectral power density limit (PDL)

Usage	Maximum spectral power density (EIRP)
Indoor and Outdoor	13 dBm / MHz

4.2.1.3 Conformance

Conformance tests for this requirement are defined in clause 5.3.3.

4.2.2 RF output power

4.2.2.1 Definition

The RF output power is the mean equivalent isotropically radiated power (EIRP) for the equipment during a transmission burst.

4.2.2.2 Limit

The maximum RF output power is applicable to the system as a whole when operated at the highest stated power level. For a smart antenna system, the limit applies to the configuration that results in the highest EIRP.

The maximum RF output power in normal wideband operation shall be as indicated in table 3.

Table 3: RF output power limit

Usage	Maximum power level (EIRP)
Indoor and Outdoor	40 dBm

4.2.2.3 Conformance

Conformance tests for this requirement are defined in clause 5.3.4.

4.2.3 Transmitter unwanted emissions

4.2.3.1 Definition

These are unwanted emissions in the spurious domain as noted in ERC Recommendation 74-01 [1] while the equipment is transmitting. The boundary where the spurious domain begins as given by ITU-R Recommendation SM.1539-1 [4] is considered to be the offset from the nominal centre frequency of the transmission by $\pm 250\%$ of the relevant occupied bandwidth (OBw) for $OBw \leq 500$ MHz and $\pm (500 \text{ MHz} + 1,5 \times OBw)$ for $OBw > 500$ MHz.

4.2.3.2 Limit

The level of unwanted emissions in the spurious domain shall conform to the limits given in table 4.

NOTE: In line with ERC Recommendation 74-01 [1] these limits apply to the power levels conducted to the antenna connector.

Table 4: Transmitter spurious emissions

Frequency range	Emission Limit	Measurement Bandwidth
30 MHz to 47 MHz	-36 dBm	100 kHz
47 MHz to 74 MHz	-54 dBm	100 kHz
74 MHz to 87,5 MHz	-36 dBm	100 kHz
87,5 MHz to 118 MHz	-54 dBm	100 kHz
118 MHz to 174 MHz	-36 dBm	100 kHz
174 MHz to 230 MHz	-54 dBm	100 kHz
230 MHz to 470 MHz	-36 dBm	100 kHz
470 MHz to 862 MHz	-54 dBm	100 kHz
862 MHz to 1 GHz	-36 dBm	100 kHz
1 GHz to 132 GHz	-30 dBm	1 MHz

4.2.3.3 Conformance

Conformance tests for this requirement are defined in clause 5.3.5.

4.2.4 Receiver unwanted emissions

4.2.4.1 Definition

These are unwanted emissions in the spurious domain as noted in ERC Recommendation 74-01 [1] while the equipment is receiving a transmission.

4.2.4.2 Limit

The level of unwanted emissions in the spurious domain shall conform to the limits given in table 5.

NOTE: In line with ERC Recommendation 74-01 [1] these limits apply to the power levels conducted to the antenna connector.

Table 5: Receiver spurious emissions

Frequency band	Emission Limit	Measurement Bandwidth
30 MHz to 1 GHz	-57 dBm	100 kHz
1 GHz to 132 GHz	-47 dBm	1 MHz

4.2.4.3 Conformance

Conformance tests for this requirement are defined in clause 5.3.6.

4.2.5 Medium access protocol

4.2.5.1 Definition

A medium access protocol is a mechanism designed to facilitate spectrum sharing with other devices in the wireless network.

4.2.5.2 Requirement

A medium access protocol shall be implemented by the equipment and shall be active under all circumstances.

4.2.6 Integral antenna

4.2.6.1 Definition

An integral antenna is designed as a fixed part of the equipment, without the use of an external connector and as such cannot be disconnected from the equipment by a user with the intent to connect another antenna.

4.2.6.2 Requirement

An integral antenna shall be used to provide interference protection from these licence-exempt RLAN applications.

5 Testing for compliance with technical requirements

5.1 Environmental conditions for testing

Tests defined in the present document shall be carried out at representative points within the boundary limits of the declared operational environmental profile.

Where technical performance varies subject to environmental conditions, tests shall be carried out under a sufficient variety of environmental conditions (within the boundary limits of the declared operational environmental profile) to give confidence of compliance for the affected technical requirements.

5.2 Interpretation of the measurement results

The interpretation of the results recorded in a test report for the measurements described in the present document shall be as follows:

- the measured value related to the corresponding limit will be used to decide whether an equipment meets the requirements of the present document;
- the value of the measurement uncertainty for the measurement of each parameter shall be included in the test report;
- the recorded value of the measurement uncertainty shall be, for each measurement, equal to or lower than the figures in table 6.

For the test methods, according to the present document, the measurement uncertainty figures shall be calculated and shall correspond to an expansion factor (coverage factor) $k = 1,96$ or $k = 2$ (which provide confidence levels of respectively 95 % and 95,45 % in the case where the distributions characterizing the actual measurement uncertainties are normal (Gaussian)). Principles for the calculation of measurement uncertainty are contained in TR 100 028 [3].

Table 6 is based on such expansion factors.

Table 6: Maximum measurement uncertainty

Parameter	Uncertainty
RF Frequency	$\pm 1 \times 10^{-5}$
RF power, radiated	± 6 dB
Spurious emissions, radiated	± 6 dB
Humidity	± 5 %
Temperature	± 1 °C
Time	± 10 %

5.3 Essential radio test suites

5.3.1 Product Information

The following information shall be stated by the manufacturer in order to carry out the test suites and/or to declare compliance to technical requirements for which no conformance test is included in the present document.

- The channel plan(s), being the centre frequencies that the UUT is capable of tuning. If the equipment is capable of supporting multiple channel plans in the course of normal operation (e.g. offering different sizes of normal wideband operation), each distinct channel plan and its related occupied bandwidth for normal wideband operation must be stated.
- The test modulation(s) used by the UUT.
- The medium access protocol(s) used by the UUT.
- The integral antenna design used by the equipment and measures to prevent the user from connecting a different antenna.

5.3.2 Test modulation, frequency and configuration

The test modulation used should be representative of normal use of the equipment. Where the equipment is not capable of continuous RF transmission, the test modulation shall be such that:

- The generated RF transmission is the same for each transmission.
- Transmissions occur regularly in time.
- Sequences of transmissions can be repeated accurately.

If the equipment used multiple modulation methods with different RF characteristics, the modulation that produces the worst values for each essential radio test shall be used and this modulation shall be stated along with the rationale for why this modulation produces worse values than other modulation methods used by the equipment.

All tests shall be conducted at the following channels within the stated channel plan(s):

- The channel with the lowest operating frequency.
- The channel with the highest operating frequency.
- The channel with the frequency closest to the midpoint of the stated operating frequency range.

If the UUT is capable of supporting multiple occupied bandwidths for wideband normal operations, tests must be conducted for each one of them.

When applicable, RF output power shall also be tested during narrowband activity operation.

The Channel Separation (ChS) value shall be calculated based on the minimum separation (in MHz) between any two centre channel frequencies in the channel plan.

In the case that the RF power level is adjustable, all measurements shall be made with the highest power level available.

In the case of smart antenna systems, the UUT should be configured to deliver the highest RF output power to the measurement equipment, and the method to do this shall be documented in the test report.

Radiated measurements shall be used in all cases given the use of integral antennas and the lack of suitable methods for conducted measurements in this type of equipment.

5.3.3 Spectral power density

The maximum spectral power density, subject to the conditions outlined in clauses 5.1, 5.2 and 5.3.2 shall be measured using a test site as described in annex C and applicable measurement procedures in annex D shall be measured and recorded for conformance with the requirements in clause 4.2.1.

The maximum spectral power density shall be determined using a spectrum analyser of adequate bandwidth for the type of modulation being used in combination with a RF power meter.

For the purpose of this test, the minimum transmitter on time shall be 10 μ s. For equipment where the transmitter on time is less than 10 μ s, the method of measurement shall be documented in the test report.

The test procedure shall be as follows:

Step 1:

The spectrum analyser shall use the following settings:

- a) Centre frequency: The centre frequency of the channel under test.
- b) Resolution bandwidth: 1 MHz.
- c) Video bandwidth: 1 MHz.
- d) Frequency span: $2 \times$ Nominal channel bandwidth.
- e) Detector: Peak.
- f) Trace mode: Max hold.

Step 2:

When the trace is complete, find the peak value of the power envelope and record the frequency.

Step 3:

Make the following changes to the settings of the spectrum analyzer:

- a) Centre frequency: Equal to the frequency recorded in step 2.
- b) Resolution bandwidth: 1 MHz.
- c) Video bandwidth: 1 MHz.
- d) Frequency span: 3 MHz.
- e) Sweep time: 1 minute.
- f) Detector: RMS Average, Sample, or Average (excepting Video Average).
- g) Trace mode: Max hold.

For devices with an Occupied Bandwidth (OBw) greater than 100 MHz, a resolution bandwidth (RBw) other than 1 MHz as specified in step 3 may be used. This resolution bandwidth shall not be less than 1 MHz nor greater than 100 MHz. If a resolution bandwidth other than 1 MHz is employed, the power density limit that will be used in step 4 shall be $PDL(RBw) = PDL(1 \text{ MHz}) + 10 \times \log_{10}(RBw)$ where RBw is the resolution bandwidth in MHz that is employed, PDL(1 MHz) is the power density limit at 1 MHz resolution bandwidth, and PDL(RBw) is the power density limit at the resolution bandwidth used. The video bandwidth shall be the same as the resolution bandwidth, and the frequency span shall be three times this substitute resolution bandwidth.

Step 4:

When the trace is complete, capture the trace, for example, using the "View" option on the spectrum analyser.

Find the peak value of the trace and place the analyser marker on this peak. This level is recorded as the highest mean power (spectral power density) D in a 1 MHz band (or other substitute resolution as noted above).

Alternatively, where a spectrum analyser is equipment with a facility to measure spectral power density, this facility may be used to display the spectral power density D in dBm/1 MHz (or other substitute resolution as noted above).

The maximum EIRP spectral density is calculated from the above measured power density (D) and the observed duty cycle x, according to the formula below and shall be recorded in the test report. Note that PD is specified for a 1 MHz bandwidth unless a substitute resolution is used as noted above.

$$h) \quad PD = D + 10 \times \log_{10}(1/x).$$

Where the spectrum analyser bandwidth is non-Gaussian, a suitable correction factor shall be determined and applied.

5.3.4 RF output power

The RF output power, subject to the conditions outlined in clauses 5.1, 5.2 and 5.3.2, shall be measured using a test site as described in annex C and applicable measurement procedures in annex D shall be measured and recorded for conformance with the requirements in clause 4.2.2.

The centre frequency of all equipment shall be verified as being in the 60 GHz band.

Step 1:

- a) Using suitable attenuators, the measurement equipment shall be coupled to a matched diode detector or equivalent thereof. The output of the diode detector shall be connected to the vertical channel of an oscilloscope or equivalent power measurement equipment.
- b) The combination of the diode detector and the oscilloscope shall be capable of faithfully reproducing the duty cycle of the transmitter output signal.
- c) The observed duty cycle of the transmitter (Tx on / (Tx on + Tx off)) shall be noted as x ($0 < x \leq 1$), and recorded in the test report. For the purpose of testing, the equipment shall be operated with a duty cycle that is equal to or greater than 0,1.

Step 2:

- d) The RF output power of the transmitter when operated at the highest power level shall be measured using a spectrum analyser with an integration factor that exceeds the repetition period of the transmitter by a factor of 5 or more. The observed value shall be noted as "A" (in dBm).
- e) The EIRP shall be calculated from the above measured power output A (in dBm) and the observed duty cycle x according to the formula below shall be recorded.
- f) $P_H = A + 10 \times \log_{10}(1/x)$.

5.3.5 Transmitter unwanted emissions

The transmitter unwanted emissions, subject to the conditions outlined in clauses 5.1, 5.2 and 5.3.2, shall be measured using a test site as described in annex C and applicable measurement procedures in annex D, shall be measured and recorded for conformance with the requirements in clause 4.2.3, taking into account the actual antenna gain of the UUT.

In case of radiated measurements on antenna array systems using symmetrical power distribution across the available transmit chains, the UUT should, where possible, be configured so that only one transmit chain (antenna) is activated while the other transmit chains are disabled. Where this is not possible, the method used shall be documented in the test report.

If only one transmit chain was tested, the result for the active transmit chain shall be corrected to be valid for the whole system (all transmit chains).

NOTE: The emission power (mW) for one transmit chain needs to be multiplied with the number of transmit chains to obtain the total emission power of the system.

For the purposes of these tests, the UUT shall be configured to operate at its maximum duty cycle and maximum RF output power level.

5.3.5.1 Pre-scan

The test procedure below shall be used to identify potential unwanted emissions of the UUT.

Step 1:

The sensitivity of the spectrum analyser should be such that the noise floor is at least 6 dB below the limits given in table 2.

Step 2:

The emissions shall be measured over the range 30 MHz to 1 GHz:

- a) Resolution bandwidth: 100 kHz.
- b) Video bandwidth: 100 kHz.
- c) Detector mode: Average.
- d) Trace mode: Max hold.
- e) Sweep time: For non-continuous transmissions, the sweep time shall be sufficiently long, such that for each 100 kHz frequency step, the measurement time is greater than two transmissions of the UUT.

The emissions shall be measured over the range 1 GHz to 132 GHz:

- f) Resolution bandwidth: 1 MHz.
- g) Video bandwidth: 1 MHz.
- h) Detector mode: Average.
- i) Trace mode: Max hold.
- j) Sweep time: For non-continuous transmissions, the sweep time shall be sufficiently long, such that for each 1 MHz frequency step, the measurement time is greater than two transmissions of the UUT.

If equipment capable of measuring 132 GHz is not available, the maximum frequency of measurement shall be recorded.

Any emissions identified during the sweeps above that fall within the 6 dB range below the applicable limit shall be individually measured using the procedure in clause 5.3.5.2 and compared to the limits given in table 2. If measurements are conducted at a different distance than specified, then calculations for the equivalent field strength values shall be shown.

5.3.5.2 Identified emissions

Unwanted emissions within the lower spurious domain or the upper spurious domain that are identified during the pre-scan measurements above shall be accurately measured per the procedure below.

The lower spurious domain is defined as the range from the minimum frequency measured to either the nominal centre frequency - 250 % of the ChS for $\text{ChS} \leq 500$ MHz or the nominal centre frequency - (500 MHz + 1,5 × ChS) for $\text{ChS} > 500$ MHz.

The upper spurious domain is defined as the range from either the nominal centre frequency + 250 % of the ChS for $\text{ChS} \leq 500$ MHz or the nominal centre frequency + (500 MHz + 1,5 × ChS) for $\text{ChS} > 500$ MHz to the maximum frequency measured.

The steps below shall be used to accurately measure the individual unwanted emissions identified during the pre-scan measurements above.

For continuous transmit signals, a measurement using the Video Average detector of the spectrum analyser is permitted. Otherwise, the measurement shall be made only over the "on" part of the transmission.

Step 1:

The level of the emissions shall be measured in the time domain, using the following spectrum analyser settings:

- a) Centre frequency: Frequency of emission identified during the pre-scan.
- b) Resolution bandwidth: 100 kHz if < 1 GHz; 1 MHz if > 1 GHz.
- c) Video bandwidth: 100 kHz if < 1 GHz; 1 MHz if > 1 GHz.
- d) Frequency span: 0 Hz.
- e) Sweep time: Suitable to capture one transmission burst.
- f) Trigger: Video trigger.
- g) Detector: Average.
- h) Trace mode: Clear write.

The centre frequency (fine tune) shall be adjusted to capture the highest level of one burst of the emission to be measured.

Step 2:

Change the following setting on the spectrum analyser:

- i) Detector: Video average, minimum of 100 sweeps.

The measured value is the average power of this emission during the on-time of the burst. The value shall be recorded and compared with the limit in table 2.

5.3.6 Receiver unwanted emissions

The receiver unwanted emissions, subject to the conditions outlined in clauses 5.1, 5.2 and 5.3.2, shall be measured using a test site as described in annex C and applicable measurement procedures in annex D, shall be measured and recorded for conformance with the requirements in clause 4.2.4, taking into account the actual antenna gain of the UUT.

In case of radiated measurements on antenna array systems using identical receive chains, the UUT should, where possible, be configured so that only one receive chain (antenna) is activated while the other receive chains are disabled. Where this is not possible, the method used shall be documented in the test report.

If only one receive chain was tested, the result for the active receive chain shall be corrected to be valid for the whole system (all receive chains).

NOTE: The emission power for one receive chain needs to be multiplied with the number of receive chains to obtain the total emission power of the system.

The UUT shall be configured to a continuous receive mode or operated in a mode where no transmission occur.

5.3.6.1 Pre-scan

The test procedure below shall be used to identify potential unwanted emissions of the UUT.

Step 1:

The sensitivity of the spectrum analyser should be such that the noise floor is at least 6 dB below the limits given in table 3.

Step 2:

The emissions shall be measured over the range 30 MHz to 1 GHz:

- a) Resolution bandwidth: 100 kHz.
- b) Video bandwidth: 100 kHz.
- c) Detector mode: Average.
- d) Trace mode: Max hold.

The emissions shall be measured over the range 1 GHz to 132 GHz:

- e) Resolution bandwidth: 1 MHz.
- f) Video bandwidth: 1 MHz.
- g) Detector mode: Average.
- h) Trace mode: Max hold.

If equipment capable of measuring 132 GHz is not available, the maximum frequency of measurement shall be recorded.

Any emissions identified during the sweeps above that fall within the 6 dB range below the applicable limit shall be individually measured using the procedure in clause 5.3.6.2 and compared to the limits given in table 3.

5.3.6.2 Identified emissions

Unwanted emissions that are identified during the pre-scan measurements above shall be accurately measured per the procedure below.

The measured values shall be recorded and compared with the limits in table 3. If measurements are conducted at a different distance than specified, then calculations for the equivalent field strength values shall be shown.

The following spectrum analyser settings shall be used:

- a) Centre frequency: Frequency of emission identified during the pre-scan.
- b) Resolution bandwidth: 100 kHz if < 1 GHz; 1 MHz if > 1 GHz.
- c) Video bandwidth: 100 kHz if < 1 GHz; 1 MHz if > 1 GHz.
- d) Detector mode: Average.
- e) Trace mode: Max hold.

Annex A (normative): HS Requirements and conformance Test specifications Table (HS-RTT)

The HS Requirements and conformance Test specifications Table (HS-RTT) in table A.1 serves a number of purposes, as follows:

- it provides a statement of all the requirements in words and by cross reference to (a) specific clause(s) in the present document or to (a) specific clause(s) in (a) specific referenced document(s);
- it provides a statement of all the test procedures corresponding to those requirements by cross reference to (a) specific clause(s) in the present document or to (a) specific clause(s) in (a) specific referenced document(s);
- it qualifies each requirement to be either:
 - Unconditional: meaning that the requirement applies in all circumstances; or
 - Conditional: meaning that the requirement is dependant on the manufacturer having chosen to support optional functionality defined within the schedule.
- in the case of Conditional requirements, it associates the requirement with the particular optional service or functionality;
- it qualifies each test procedure to be either:
 - Essential: meaning that it is included with the Essential Radio Test Suite and therefore the requirement shall be demonstrated to be met in accordance with the referenced procedures;
 - Other: meaning that the test procedure is illustrative but other means of demonstrating compliance with the requirement are permitted.

Table A.1: HS Requirements and conformance Test specifications Table (HS-RTT)

Harmonized Standard EN 302 567						
The following requirements and test specifications are relevant to the presumption of conformity under the article 3.2 of the R&TTE Directive						
Requirement			Requirement Conditionality		Test Specification	
No	Description	Reference: Clause No	U/C	Condition	E/O	Reference: Clause No
1	Spectral power density	4.2.1	U		E	5.3.3
2	RF output power	4.2.2	U		E	5.3.4
3	Transmitter unwanted emissions	4.2.3	U		E	5.3.5
4	Receiver unwanted emissions	4.2.4	U		E	5.3.6
5	Medium access protocol	4.2.5	U		X	
6	Integral antenna	4.2.6	U		X	

Key to columns:

Requirement:

No A unique identifier for one row of the table which may be used to identify a requirement or its test specification.

Description A textual reference to the requirement.

Clause Number Identification of clause(s) defining the requirement in the present document unless another document is referenced explicitly.

Requirement Conditionality:

U/C Indicates whether the requirement is to be *unconditionally* applicable (U) or is *conditional* upon the manufacturers claimed functionality of the equipment (C).

Condition Explains the conditions when the requirement shall or shall not be applicable for a technical requirement which is classified "conditional".

Test Specification:

E/O Indicates whether the test specification forms part of the Essential Radio Test Suite (E) or whether it is one of the Other Test Suite (O).

NOTE: All tests whether "E" or "O" are relevant to the requirements. Rows designated "E" collectively make up the Essential Radio Test Suite; those designated "O" make up the Other Test Suite; for those designated "X" there is no test specified corresponding to the requirement. The completion of all tests classified "E" as specified with satisfactory outcomes is a necessary condition for a presumption of conformity. Compliance with requirements associated with tests classified "O" or "X" is a necessary condition for presumption of conformity, although conformance with the requirement may be claimed by an equivalent test or by manufacturer's assertion supported by appropriate entries in the technical construction file.

Clause Number Identification of clause(s) defining the test specification in the present document unless another document is referenced explicitly. Where no test is specified (that is, where the previous field is "X") this field remains blank.

Annex B (informative): The EN title in the official languages

The enlargement of the European Union (EU) resulted in a requirement from the EU for a larger number of languages for the translation of the titles of Harmonized Standards and mandated ENs that are to be listed in the Official Journal to support the implementation of this legislation.

For this reason the title translation concerning the present document can be consulted via the [e-approval](#) application.

Annex C (normative): Test sites and arrangements for radiated measurements

C.1 Test sites

C.1.1 Open air test sites

The term "open air" should be understood from an electromagnetic point of view. Such a test site may be really in open air or alternatively with walls and ceiling transparent to the radio waves at the frequencies considered.

An open air test site may be used to perform the measurements using the radiated measurement methods described in clause 5.3. Absolute or relative measurements may be performed on transmitters or on receivers; absolute measurements of field strength require a calibration of the test site.

A measuring distance of at least 3 m shall be used for measurements at frequencies up to 1 GHz. For frequencies above 1 GHz, any suitable measuring distance may be used. The equipment size (excluding the antenna) shall be less than 20 % of the measuring distance. The height of the equipment or of the substitution antenna shall be 1,5 m; the height of the test antenna (transmit or receive) shall vary between 1 m and 4 m.

Sufficient precautions shall be taken to ensure that reflections from extraneous objects adjacent to the site do not degrade the measurement results, in particular:

- no extraneous conducting objects having any dimension in excess of a quarter wavelength of the highest frequency tested shall be in the immediate vicinity of the site;
- all cables shall be as short as possible; as much of the cables as possible shall be on the ground plane or preferably below; and the low impedance cables shall be screened.

The general measurement arrangement is shown in figure C.1.

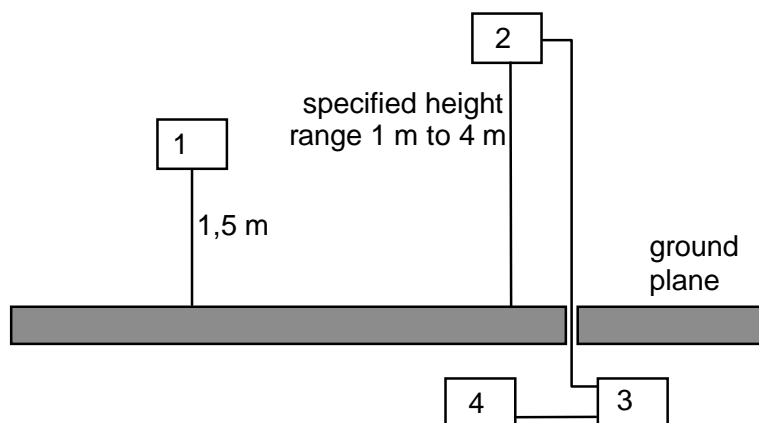

- 1) Equipment under test.
- 2) Test antenna.
- 3) High pass filter (as required).
- 4) Spectrum analyser or measuring receiver.

Figure C.1: Measuring arrangement

C.1.2 Anechoic chamber

C.1.2.1 General

An anechoic chamber is a well shielded chamber covered inside with radio frequency absorbing material and simulating a free space environment. It is an alternative site on which to perform the measurements using the radiated measurement methods described in clause 5.3. Absolute or relative measurements may be performed on transmitters or on receivers. Absolute measurements of field strength require a calibration of the anechoic chamber. The test antenna, equipment under test and substitution antenna are used in a way similar to that at the open air test site, but are all located at the same fixed height above the floor.

C.1.2.2 Description

An anechoic chamber should meet the requirements for shielding loss and wall return loss as shown in figure C.2. Figure C.3 shows an example of the construction of an anechoic chamber having a base area of 5 m by 10 m and a height of 5 m. The ceiling and walls are coated with pyramidally formed absorbers approximately 1 m high. The base is covered with special absorbers which form the floor. The available internal dimensions of the chamber are 3 m × 8 m × 3 m, so that a maximum measuring distance of 5 m in the middle axis of this chamber is available. The floor absorbers reject floor reflections so that the antenna height need not be changed. Anechoic chambers of other dimensions may be used. Alternatively, an anechoic chamber having a base area of 2,5 m × 3 m and a height of 5 m may also be used.

C.1.2.3 Influence of parasitic reflections

For free-space propagation in the far field, the relationship of the field strength E and the distance R is given by $E = E_0 \times (R_0/R)$, where E_0 is the reference field strength and R_0 is the reference distance. This relationship allows relative measurements to be made as all constants are eliminated within the ratio and neither cable attenuation nor antenna mismatch or antenna dimensions are of importance.

If the logarithm of the foregoing equation is used, the deviation from the ideal curve may be easily seen because the ideal correlation of field strength and distance appears as a straight line. The deviations occurring in practice are then clearly visible. This indirect method shows quickly and easily any disturbances due to reflections and is far less difficult than the direct measurement of reflection attenuation.

With an anechoic chamber of the dimensions given above at low frequencies below 100 MHz there are no far field conditions, but the wall reflections are stronger, so that careful calibration is necessary. In the medium frequency range from 100 MHz to 1 GHz the dependence of the field strength to the distance meets the expectations very well. Above 1 GHz, because more reflections will occur, the dependence of the field strength to the distance will not correlate so closely.

C.1.2.4 Calibration and mode of use

The calibration and mode of use is the same as for an open air test site, the only difference being that the test antenna does not need to be raised and lowered whilst searching for a maximum, which simplifies the method of measurement.

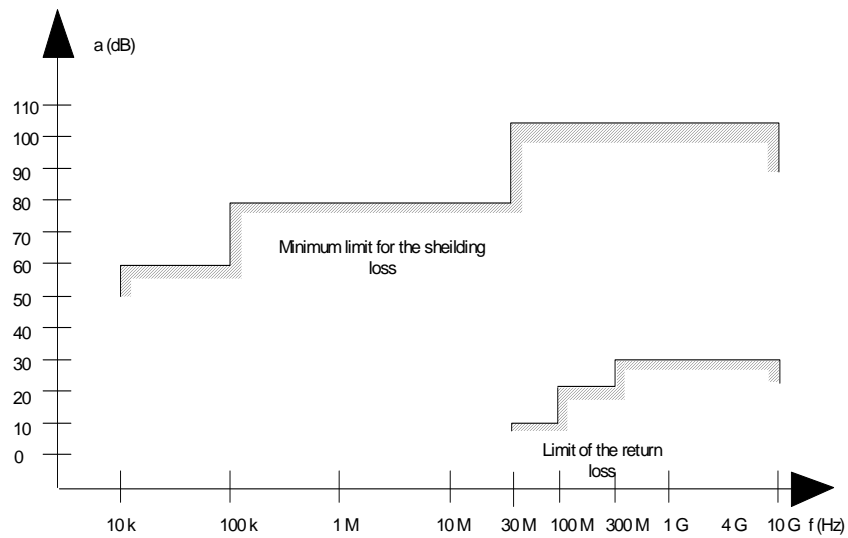

Figure C.2: Specification for shielding and reflections

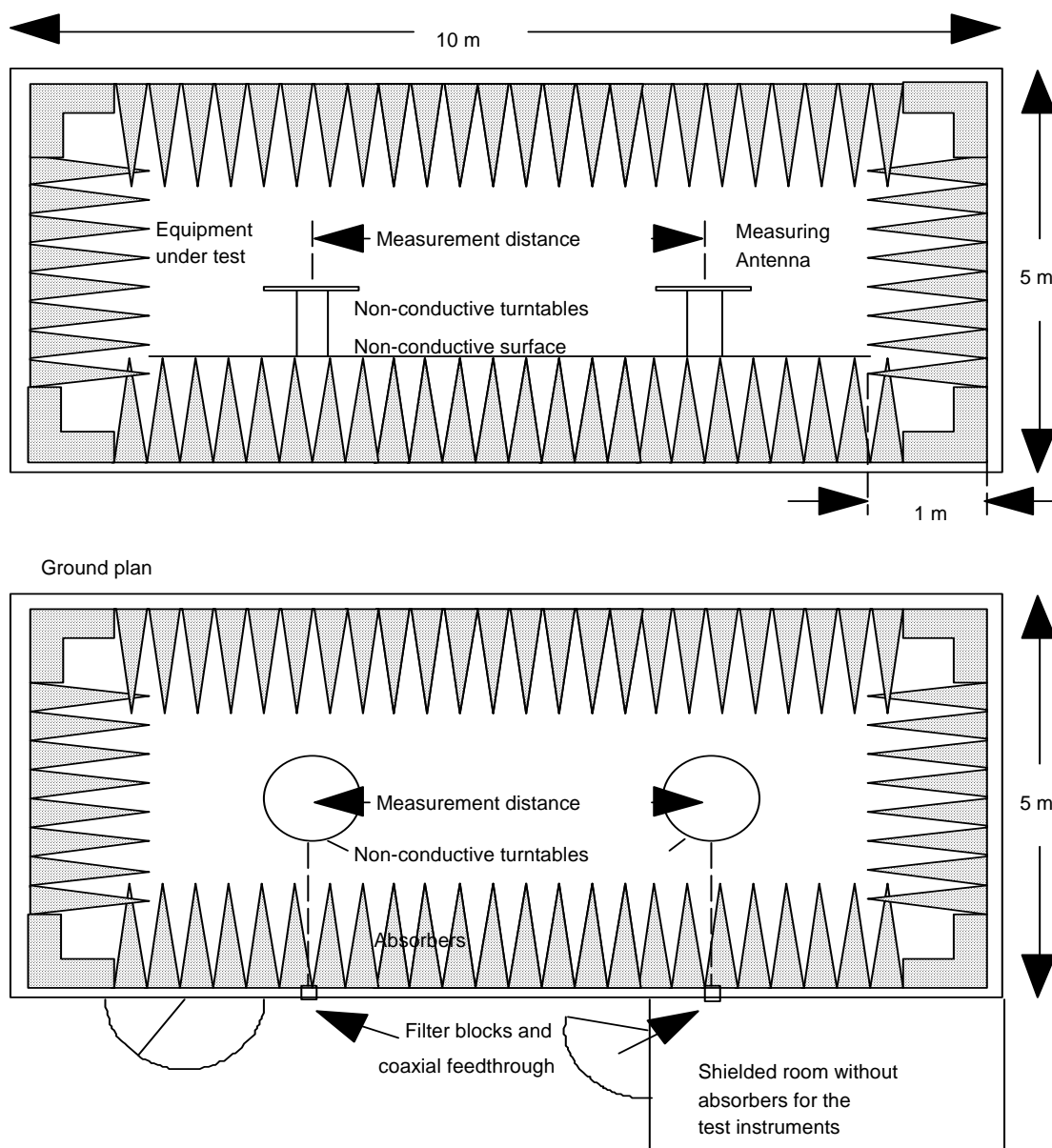

Figure C.3: Anechoic shielded chamber for simulated free space measurements

C.2 Test antenna

When the test site is used for radiated measurements the test antenna shall be used to detect the field from both the test sample and the substitution antenna. When the test site is used for the measurement of receiver characteristics the antenna shall be used as a transmitting antenna. This antenna shall be mounted on a support capable of allowing the antenna to be used in either horizontal or vertical polarization and for the height of its centre above the ground to be varied over the specified range. Preferably test antennae with pronounced directivity should be used. The size of the test antenna along the measurement axis shall not exceed 20 % of the measuring distance. The antenna shall include any necessary up/down conversion to an intermediate frequency for practical signal transport to/from related test equipment.

C.3 Substitution antenna

The substitution antenna shall be used to replace the equipment under test in substitution measurements. For measurements below 1 GHz the substitution antenna shall be a half wavelength dipole resonant at the frequency under consideration, or a shortened dipole, calibrated to the half wavelength dipole. For measurements between 1 GHz and 4 GHz either a half wavelength dipole or a horn radiator may be used. For measurements above 4 GHz a horn radiator shall be used. The centre of this antenna shall coincide with the reference point of the test sample it has replaced. This reference point shall be the volume centre of the sample when its antenna is mounted inside the cabinet, or the point where an outside antenna is connected to the cabinet.

The distance between the lower extremity of the dipole and the ground shall be at least 30 cm.

NOTE: The gain of a horn antenna is generally expressed relative to an isotropic radiator.

Annex D (normative): General description of measurement

This annex gives the general methods of measurements for RF signals using the test sites and arrangements described in annex C.

D.1 Radiated measurements

Radiated measurements shall be performed with the aid of a test antenna and measurement instruments as described in annex C. The test antenna and measurement instrument shall be calibrated according to the procedure defined in this annex. The equipment to be measured and the test antenna shall be oriented to obtain the maximum emitted power level. This position shall be recorded in the measurement report. The frequency range shall be measured in this position.

Preferably, radiated measurements shall be performed in an anechoic chamber. For other test sites corrections may be needed (see annex C). The following test procedure applies:

- a) A test site which fulfils the requirements of the specified frequency range of this measurement shall be used. The test antenna shall be oriented initially for vertical polarization unless otherwise stated and the transmitter under test shall be placed on the support in its standard position (clause C.1.1) and switched on.
- b) For average power measurements a non-selective voltmeter or wide band spectrum analyser shall be used. For other measurements a spectrum analyser or selective voltmeter shall be used and tuned to the measurement frequency.

In either case a) or b), the test antenna shall be raised or lowered, if necessary, through the specified height range until the maximum signal level is detected on the spectrum analyser or selective voltmeter.

The test antenna need not be raised or lowered if the measurement is carried out on a test site according to clause C.1.2.

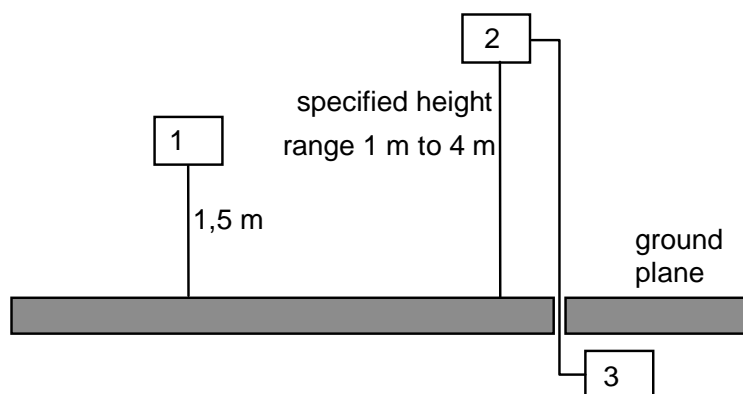

- 1) Equipment under test.
- 2) Test antenna.
- 3) Spectrum analyser or measuring receiver.

Figure D.1: Measurement arrangement No.1

- c) The transmitter shall be rotated through 360° about a vertical axis until a higher maximum signal is received.
- d) The test antenna shall be raised or lowered again, if necessary, through the specified height range until a maximum is obtained. This level shall be recorded.

NOTE: This maximum may be a lower value than the value obtainable at heights outside the specified limits.

The test antenna need not be raised or lowered if the measurement is carried out on a test site according to clause C.1.2. This measurement shall be repeated for horizontal polarization.

D.2 Substitution measurement

The actual signal generated by the measured equipment may be determined by means of a substitution measurement in which a known signal source replaces the device to be measured, see figure D.2.

Preferably, this method of measurement shall be used in an anechoic chamber. For other test sites corrections may be needed, see annex C.

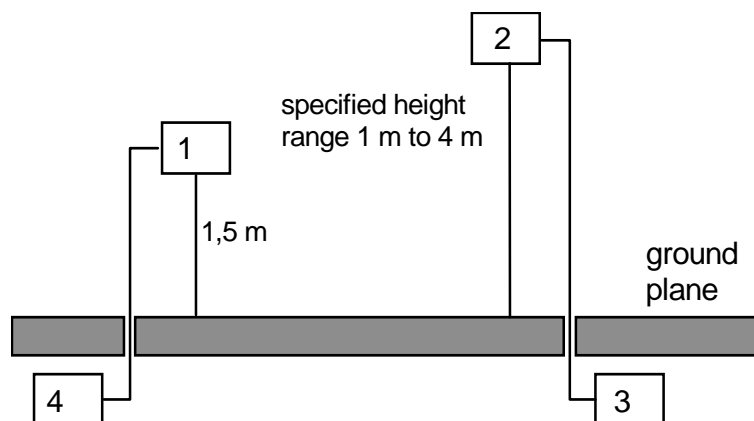

- 1) Substitution antenna.
- 2) Test antenna.
- 3) Spectrum analyser or selective voltmeter.
- 4) Signal generator.

Figure D.2: Measurement arrangement No.2

- a) Using measurement arrangement No.2, the substitution antenna shall replace the transmitter antenna in the same position and in vertical polarization. The frequency of the signal generator shall be adjusted to the measurement frequency. The test antenna shall be raised or lowered, if necessary, to ensure that the maximum signal is still received. The input signal to the substitution antenna shall be adjusted in level until an equal or a known related level to that detected from the transmitter is obtained in the test receiver:
 - the test antenna need not be raised or lowered if the measurement is carried out on a test site according to clause C.1.2;
 - the radiated power is equal to the power supplied by the signal generator, increased by the known relationship if necessary and after corrections due to the gain of the substitution antenna and the cable loss between the signal generator and the substitution antenna.
- b) This measurement shall be repeated with horizontal polarization.

Annex E (informative): Bibliography

- Directive 2004/108/EC of the European Parliament and of the Council of 15 December 2004 on the approximation of the laws of the Member States relating to electromagnetic compatibility and repealing Directive 89/336/EEC (EMC Directive).
- Directive 2006/95/EC of the European Parliament and of the Council of 12 December 2006 on the harmonisation of the laws of Member States relating to electrical equipment designed for use within certain voltage limits (LV Directive).

History

Document history		
V1.1.1	March 2009	Publication
V1.2.0	June 2011	Public Enquiry PE 20111027: 2011-06-29 to 2011-10-27
V1.2.1	November 2011	Vote V 20120107: 2011-11-08 to 2012-01-09