

ETSI EN 302 561 V2.1.1 (2016-03)



HARMONISED EUROPEAN STANDARD

**Land Mobile Service;
Radio equipment using constant or non-constant envelope
modulation operating in a channel bandwidth of
25 kHz, 50 kHz, 100 kHz or 150 kHz;
Harmonised Standard covering the essential requirements
of article 3.2 of the Directive 2014/53/EU**

Reference

REN/ERM-TGDMMR-343

Keywords

data, mobile, PMR, radio, repeater, TETRA

ETSI

650 Route des Lucioles
F-06921 Sophia Antipolis Cedex - FRANCE

Tel.: +33 4 92 94 42 00 Fax: +33 4 93 65 47 16

Siret N° 348 623 562 00017 - NAF 742 C
Association à but non lucratif enregistrée à la
Sous-Préfecture de Grasse (06) N° 7803/88

Important notice

The present document can be downloaded from:
<http://www.etsi.org/standards-search>

The present document may be made available in electronic versions and/or in print. The content of any electronic and/or print versions of the present document shall not be modified without the prior written authorization of ETSI. In case of any existing or perceived difference in contents between such versions and/or in print, the only prevailing document is the print of the Portable Document Format (PDF) version kept on a specific network drive within ETSI Secretariat.

Users of the present document should be aware that the document may be subject to revision or change of status. Information on the current status of this and other ETSI documents is available at
<https://portal.etsi.org/TB/ETSIDeliverableStatus.aspx>

If you find errors in the present document, please send your comment to one of the following services:
<https://portal.etsi.org/People/CommiteeSupportStaff.aspx>

Copyright Notification

No part may be reproduced or utilized in any form or by any means, electronic or mechanical, including photocopying and microfilm except as authorized by written permission of ETSI.

The content of the PDF version shall not be modified without the written authorization of ETSI.
The copyright and the foregoing restriction extend to reproduction in all media.

© European Telecommunications Standards Institute 2016.
All rights reserved.

DECT™, **PLUGTESTS™**, **UMTS™** and the ETSI logo are Trade Marks of ETSI registered for the benefit of its Members.
3GPP™ and **LTE™** are Trade Marks of ETSI registered for the benefit of its Members and of the 3GPP Organizational Partners.
GSM® and the GSM logo are Trade Marks registered and owned by the GSM Association.

Contents

Intellectual Property Rights	7
Foreword.....	7
Modal verbs terminology.....	7
1 Scope	8
2 References	8
2.1 Normative references	8
2.2 Informative references.....	9
3 Definitions, symbols and abbreviations	10
3.1 Definitions.....	10
3.2 Symbols.....	11
3.3 Abbreviations	11
4 General	12
4.1 Testing.....	12
4.1.1 Choice of model for testing	12
4.1.1.0 General.....	12
4.1.1.1 Auxiliary test equipment	12
4.1.1.2 Declarations by the supplier.....	12
4.1.2 Presentation of equipment for testing purposes	13
4.2 Mechanical and electrical design.....	13
4.2.1 General.....	13
4.2.2 Controls	13
4.2.3 Transmitter shut-off facility.....	13
4.3 Marking.....	13
4.4 Testing using bit streams or messages.....	13
4.5 Measuring continuous mode equipment.....	13
4.6 Measuring discontinuous mode equipment	14
4.7 Constant and non-constant envelope modulation	14
4.8 Multi-Mode equipment.....	14
4.9 Environmental profile.....	14
5 Test conditions, power sources and ambient temperatures	14
5.1 Normal and extreme test conditions	14
5.2 Test power source.....	14
5.3 Normal test conditions.....	15
5.3.1 Normal temperature and humidity	15
5.3.2 Normal test power source	15
5.3.2.1 Mains voltage.....	15
5.3.2.2 Regulated lead-acid battery power sources used on vehicles.....	15
5.3.2.3 Other power sources.....	15
5.4 Extreme test conditions	15
5.4.1 Extreme temperatures	15
5.4.2 Extreme test source voltages.....	15
5.4.2.1 Mains voltage.....	15
5.4.2.2 Regulated lead-acid battery power sources used on vehicles.....	15
5.4.2.3 Power sources using other types of batteries.....	16
5.4.2.4 Other power sources.....	16
5.5 Procedure for tests at extreme temperatures.....	16
5.5.0 Thermal balance.....	16
5.5.1 Procedure for equipment designed for continuous transmission.....	16
5.5.2 Procedure for equipment designed for intermittent transmission	16
5.5.3 Testing of equipment that does not have an external 50 Ω RF connector (integral antenna equipment).....	17
6 General conditions of measurement	17
6.1 Arrangements for test signals applied to the receiver input.....	17
6.2 Test load (artificial antenna).....	17

6.3	Test signals (wanted and unwanted signals).....	17
6.3.0	General.....	17
6.3.1	Transmitter test signals	17
6.3.2	Receiver test signals.....	18
6.3.3	Transmitter effective radiated power test signal (C1).....	18
6.4	Encoder	18
6.4.1	Encoder for receiver measurements	18
6.4.2	Encoder for transmitter measurements	18
6.5	Transceiver data interface.....	19
6.6	Impedance	19
6.7	PEP.....	19
6.8	Duplex equipment	19
6.9	Modes of operation of the transmitter	19
6.10	Measurement filter definition	19
6.11	TMO Repeaters	20
7	Technical characteristics of the transmitter.....	20
7.1	Transmitter output power (conducted)	20
7.1.0	General.....	20
7.1.1	Definitions	20
7.1.2	Method of measurement	20
7.1.3	Limits.....	21
7.2	Maximum effective radiated power.....	21
7.2.0	General.....	21
7.2.1	Definition.....	21
7.2.2	Method of measurement	21
7.2.2.1	Evaluation of CW-to-PEP correction factor for signal C1	21
7.2.2.2	Measurements on a test site.....	21
7.2.3	Limit	22
7.3	Adjacent and alternate channel power.....	23
7.3.1	Definition.....	23
7.3.2	Method of measurement	23
7.3.3	Limits.....	24
7.3.3.1	Limits for TMO Repeaters	24
7.3.3.2	Limits for all non TMO repeater equipment	25
7.4	Unwanted emissions in the spurious domain.....	25
7.4.1	Definition.....	25
7.4.2	Method of measuring the power level	25
7.4.2.1	Measurement options	25
7.4.2.2	Method of measuring conducted spurious emissions (clause 7.4.2.1 a))	26
7.4.2.3	Method of measuring the effective radiated power (clause 7.4.2.1 b))	26
7.4.2.4	Method of measuring the effective radiated power (clause 7.4.2.1 c))	27
7.4.2.5	Method of measuring wideband noise.....	27
7.4.3	Limits.....	28
7.4.3.1	Spurious emissions power.....	28
7.4.3.2	Wideband noise power.....	29
7.5	Intermodulation attenuation.....	31
7.5.0	Applicability	31
7.5.1	Definition.....	31
7.5.2	Method of measurement	31
7.5.2.1	Measurement for TMO repeater equipment.....	31
7.5.2.2	Measurement for non TMO repeater equipment.....	32
7.5.3	Limits.....	33
7.5.3.1	Limits for TMO repeater equipment	33
7.5.3.2	Limits for non TMO repeater equipment	33
7.6	Adjacent channel transient power measurements.....	33
7.6.1	Definition.....	33
7.6.2	Method of Measurement.....	33
7.6.3	Limits.....	34
7.7	Frequency error	34
7.7.0	General.....	34
7.7.1	Definition.....	34

7.7.2	Method of measurement	34
7.7.3	Limits.....	35
7.8	Out of band gain for TMO repeater equipment.....	35
7.8.0	Applicability	35
7.8.1	Definition.....	35
7.8.2	Method of measurement	35
7.8.3	Limits.....	36
7.9	Modulation accuracy	36
7.9.0	Applicability	36
7.9.1	Definition.....	36
7.9.2	Method of measurement	36
7.9.3	Limits.....	37
8	Technical characteristics of the receiver	37
8.0	Applicability.....	37
8.1	Receiver sensitivity (conducted)	37
8.1.0	General.....	37
8.1.1	Definition.....	37
8.1.2	Method of measurement	38
8.1.2.1	Method of measurement with continuous bit streams.....	38
8.1.2.2	Method of measurement with messages or packets	38
8.1.3	Limits.....	39
8.2	Maximum usable sensitivity (field strength)	39
8.2.0	General.....	39
8.2.1	Definition.....	39
8.2.2	Method of measurement	39
8.2.2.0	General	39
8.2.2.1	Method of measurement with continuous bit streams.....	40
8.2.2.2	Method of measurement with messages.....	40
8.2.3	Limits.....	41
8.3	Blocking or desensitization	43
8.3.1	Definition.....	43
8.3.2	Method of measurement	44
8.3.2.1	Method of measurement with continuous transmissions.....	44
8.3.2.2	Method of measurement with messages.....	45
8.3.3	Limits.....	45
8.4	Adjacent channel selectivity.....	46
8.4.1	Definition.....	46
8.4.2	Method of measurement	46
8.4.2.1	Method of measurement (with continuous bit stream).....	46
8.4.2.2	Method of measurement with messages.....	47
8.4.3	Limits.....	47
8.5	Spurious radiations	47
8.5.1	Definition.....	47
8.5.2	Methods of measurement.....	48
8.5.2.1	Method of measuring the power level in a specified load (clause 8.5.1 a)).....	48
8.5.2.2	Method of measuring the effective radiated power (clause 8.5.1 b)).....	48
8.5.2.3	Method of measuring the effective radiated power (clause 8.5.1 c)).....	49
8.5.3	Limits.....	49
8.6	Co-channel rejection.....	50
8.6.1	Definition.....	50
8.6.2	Method of measurement	50
8.6.2.1	Method of measurement with continuous bit streams.....	50
8.6.2.2	Method of measurement with messages (or packets).....	51
8.6.3	Limits.....	52
8.7	Intermodulation response rejection	52
8.7.1	Definition.....	52
8.7.2	Method of measurement	52
8.7.2.1	Method of measurement (with continuous bit stream).....	52
8.7.2.2	Method of measurement with messages.....	53
8.7.3	Limit	54

9	Measurement uncertainty	54
Annex A (normative):	Relationship between the present document and the essential requirements of Directive 2014/53/EU	56
Annex B (normative):	Radiated measurement.....	58
B.1	Test sites and general arrangements for measurements involving the use of radiated fields	58
B.1.0	General	58
B.1.1	Anechoic chamber	58
B.1.2	Anechoic chamber with a conductive ground plane	59
B.1.3	Open Area Test Site (OATS)	60
B.1.4	Test antenna.....	61
B.1.5	Substitution antenna	61
B.1.6	Measuring antenna	62
B.2	Guidance on the use of radiation test sites	62
B.2.0	General	62
B.2.1	Verification of the test site	62
B.2.2	Preparation of the EUT.....	62
B.2.3	Power supplies to the EUT	62
B.2.4	Range length.....	62
B.2.5	Site preparation	63
B.3	Coupling of signals.....	64
B.3.1	General	64
B.3.2	Data signals	64
Annex C (normative):	Spectrum analyser specification	65
Annex D (informative):	Change History	66
	History	67

Intellectual Property Rights

IPRs essential or potentially essential to the present document may have been declared to ETSI. The information pertaining to these essential IPRs, if any, is publicly available for **ETSI members and non-members**, and can be found in ETSI SR 000 314: "*Intellectual Property Rights (IPRs); Essential, or potentially Essential, IPRs notified to ETSI in respect of ETSI standards*", which is available from the ETSI Secretariat. Latest updates are available on the ETSI Web server (<https://ipr.etsi.org>).

Pursuant to the ETSI IPR Policy, no investigation, including IPR searches, has been carried out by ETSI. No guarantee can be given as to the existence of other IPRs not referenced in ETSI SR 000 314 (or the updates on the ETSI Web server) which are, or may be, or may become, essential to the present document.

Foreword

This Harmonised European Standard (EN) has been produced by ETSI Technical Committee Electromagnetic compatibility and Radio spectrum Matters (ERM).

The present document has been prepared under the Commission's standardisation request C(2015) 5376 final [i.9] to provide one voluntary means of conforming to the essential requirements of Directive 2014/53/EU on the harmonisation of the laws of the Member States relating to the making available on the market of radio equipment and repealing Directive 1999/5/EC [i.3].

Once the present document is cited in the Official Journal of the European Union under that Directive, compliance with the normative clauses of the present document given in table A.1 confers, within the limits of the scope of the present document, a presumption of conformity with the corresponding essential requirements of that Directive, and associated EFTA regulations.

National transposition dates	
Date of adoption of this EN:	21 March 2016
Date of latest announcement of this EN (doa):	30 June 2016
Date of latest publication of new National Standard or endorsement of this EN (dop/e):	31 December 2016
Date of withdrawal of any conflicting National Standard (dow):	31 December 2017

Modal verbs terminology

In the present document "**shall**", "**shall not**", "**should**", "**should not**", "**may**", "**need not**", "**will**", "**will not**", "**can**" and "**cannot**" are to be interpreted as described in clause 3.2 of the [ETSI Drafting Rules](#) (Verbal forms for the expression of provisions).

"**must**" and "**must not**" are **NOT** allowed in ETSI deliverables except when used in direct citation.

1 Scope

The present document covers the technical requirements for radio transmitters and receivers used in stations and technical requirements for TMO repeater in the Private Mobile Radio (PMR) service.

It applies to use in the land mobile service, operating on radio frequencies between 30 MHz and 3 GHz, with channel separations of 25 kHz, 50 kHz, 100 kHz and 150 kHz.

Table 1: Radiocommunications service frequency bands

Radiocommunications service frequency bands	
Transmit	30 MHz to 3 000 MHz
Receive	30 MHz to 3 000 MHz

It applies to equipment for continuous and/or discontinuous transmission of data and/or digital speech.

The equipment (base station and mobile station) comprises a transmitter and associated encoder and modulator and/or a receiver and associated demodulator and decoder.

The types of equipment covered by the present document are as follows:

- base station (equipment fitted with an antenna connector, intended for use in a fixed location);
- mobile station (equipment fitted with an antenna connector, normally used in a vehicle or as a transportable);
- TMO Repeater; and
- those hand portable stations:
 - a) fitted with an antenna connector; or
 - b) without an external antenna connector (integral antenna equipment), but fitted with a permanent internal or a temporary internal 50 Ω Radio Frequency (RF) connector which allows access to the transmitter output and the receiver input.

Hand portable equipment without an external or internal RF connector and without the possibility of having a temporary internal 50 Ω RF connector is not covered by the present document.

These specifications do not necessarily include all the characteristics which may be required by a user of equipment, nor do they necessarily represent the optimum performance achievable.

The present document contains requirements to demonstrate that "*... Radio equipment shall be so constructed that it both effectively uses and supports the efficient use of radio spectrum in order to avoid harmful interference*" and that "*....radio equipment supports certain features ensuring access to emergency services*" [i.3].

In addition to the present document, other ENs (e.g. ETSI EN 301 489-1 [i.7] and ETSI EN 301 489-5 [i.8]) that specify technical requirements in respect of essential requirements under the Radio Equipment Directive [i.3], may apply to equipment within the scope of the present document.

2 References

2.1 Normative references

References are either specific (identified by date of publication and/or edition number or version number) or non-specific. For specific references, only the cited version applies. For non-specific references, the latest version of the referenced document (including any amendments) applies.

Referenced documents which are not found to be publicly available in the expected location might be found at <http://docbox.etsi.org/Reference>.

NOTE: While any hyperlinks included in this clause were valid at the time of publication, ETSI cannot guarantee their long term validity.

The following referenced documents are necessary for the application of the present document.

- [1] Recommendation ITU-T O.153 (10-1992): "Basic parameters for the measurement of error performance at bit rates below the primary rate".
- [2] ETSI TR 100 028 (V1.4.1) (12-2001) (all parts): "Electromagnetic compatibility and Radio spectrum Matters (ERM); Uncertainties in the measurement of mobile radio equipment characteristics".
- [3] ETSI TR 102 273 (V1.2.1) (12-2001) (all parts): "Electromagnetic compatibility and Radio spectrum Matters (ERM); Improvement on Radiated Methods of Measurement (using test site) and evaluation of the corresponding measurement uncertainties".
- [4] ANSI C63.5 (2006): "Electromagnetic Compatibility - Radiated Emission Measurements in Electromagnetic Interference (EMI) Control - Calibration and Qualification of Antennas (9 kHz to 40 GHz)".
- [5] ETSI EN 300 392-2 (V3.4.1) (08-2010): "Terrestrial Trunked Radio (TETRA); Voice plus Data (V+D); Part 2: Air Interface (AI)".

2.2 Informative references

References are either specific (identified by date of publication and/or edition number or version number) or non-specific. For specific references, only the cited version applies. For non-specific references, the latest version of the referenced document (including any amendments) applies.

NOTE: While any hyperlinks included in this clause were valid at the time of publication, ETSI cannot guarantee their long term validity.

The following referenced documents are not necessary for the application of the present document but they assist the user with regard to a particular subject area.

- [i.1] Recommendation ITU-R SM.329-12 (2012): "Unwanted emissions in the spurious domain".
- [i.2] CEPT/ERC/REC 74-01 (2005): "Unwanted Emissions in the Spurious domain".
- [i.3] Directive 2014/53/EU of the European Parliament and of the Council of 16 April 2014 on the harmonisation of the laws of the Member States relating to the making available on the market of radio equipment and repealing Directive 1999/5/EC.

NOTE: Article 3.2 and article 10.8.

- [i.4] ETSI TS 101 789-1 (V1.1.2): "Terrestrial Trunked Radio (TETRA); TMO Repeaters; Part 1: Requirements, test methods and limits".
- [i.5] ETSI EN 300 394-1 (V3.2.1) (10-2012): "Terrestrial Trunked Radio (TETRA); Conformance testing specification; Part 1: Radio".
- [i.6] ETSI EN 303 035-1 (V1.2.1) (12-2001): "Terrestrial Trunked Radio (TETRA); Harmonized EN for TETRA equipment covering essential requirements under article 3.2 of the R&TTE Directive; Part 1: Voice plus Data (V+D)".
- [i.7] ETSI EN 301 489-1 (V1.9.2) (09-2011): "Electromagnetic compatibility and Radio spectrum Matters (ERM); ElectroMagnetic Compatibility (EMC) standard for radio equipment and services; Part 1: Common technical requirements".
- [i.8] ETSI EN 301 489-5 (V1.4.1): "ElectroMagnetic Compatibility (EMC) standard for radio equipment and services; Harmonized Standard covering the essential requirements of article 3.1b of the Directive 2014/53/EU; Part 5: Specific conditions for Private land Mobile Radio (PMR) and Terrestrial Trunked Radio (TETRA) equipment and ancillary equipment (speech and non-speech)".

- [i.9] Commission Implementing Decision C(2015) 5376 final of 4.8.2015 on a standardisation request to the European Committee for Electrotechnical Standardisation and to the European Telecommunications Standards Institute as regards radio equipment in support of Directive 2014/53/EU of the European Parliament and of the Council.
- [i.10] ETSI EN 300 793 (V1.1.1) (02-1998): "Electromagnetic compatibility and Radio spectrum Matters (ERM); Land mobile service; Presentation of equipment for type testing".

3 Definitions, symbols and abbreviations

3.1 Definitions

For the purposes of the present document, the following terms and definitions apply:

base station: equipment fitted with an antenna connector, for use with an external antenna, and intended for use in a fixed location

bit: binary digit

block: smallest quantity of information that is sent over the radio channel

NOTE: A constant number of useful bits are always sent together with the corresponding redundancy bits.

broadband repeater: repeater which is designed for operation on any combination of carriers (up to a specified maximum number) within the operating band of the repeater

burst or transmission (physical): one or several packets transmitted between power on and power off of a particular transmitter

channelized repeater: repeater which is designed for operation on a specified subset of carriers within the operating band of the repeater

NOTE: The subset of the channels may be determined during the manufacture of the repeater, or may be programmable.

conducted measurements: measurements which are made using direct 50 Ω connection to the equipment under test

data transmission systems: systems which transmit and/or receive data and/or digitized voice

downlink: signal path where base station transmits and mobile or hand portable station receives

hand portable station: equipment either fitted with an antenna connector or integral antenna, or both, normally used on a stand-alone basis, to be carried on a person or held in the hand

integral antenna: antenna designed to be connected to the equipment without the use of a 50 Ω external connector and considered to be part of the equipment

NOTE: An integral antenna may be fitted internally or externally to the equipment.

Listen Before Transmit mode (LBT): monitoring mode in which the RF channel is checked for activity before transmitting

NOTE: Examples for LBT are transceivers or systems implementing squelch or RSSI (Receiver Signal Strength Indicator) algorithms for evaluating the status of the channel.

message: user data to be transferred in one or more packets in a session

mobile station: mobile equipment fitted with an antenna connector, for use with an external antenna, normally used in a vehicle or as a transportable station

packet: one block or a contiguous stream of blocks sent by one (logical) transmitter to one particular receiver or one particular group of receivers

radiated measurements: measurements which involve the absolute measurement of a radiated field

receive band of the equipment: maximum frequency range (declared by the supplier) over which the receiver can be operated without reprogramming or realignment

session: set of inter-related exchange of packets occupying one or several windows or part thereof (if applicable)

NOTE: It corresponds to a complete interactive procedure for interchanging data between users, comprising initiation, data transmission and termination procedures. The session can be short (e.g. 2 packets), or long (e.g. one full page of text).

spurious emissions: unwanted emissions in the spurious domain

testing laboratory: laboratory that performs tests

TMO Repeater: bi-directional Radio Frequency (RF) amplifier which can amplify and transmit a received Mobile Station (MS) signal in the MS transmit band, simultaneously it can amplify and transmit a received Base Station (BS) RF signal in the BS transmit band

transmit band of the equipment: maximum frequency range (declared by the supplier) over which the transmitter can be operated without reprogramming or realignment

Trunked Mode Operation (TMO): mode of operation where a network is used for communication

uplink: signal path where mobile or hand portable station transmits and base station receives

window: set of inter-related transmissions which may be limited in time by an appropriate access protocol and corresponding occupation rules

3.2 Symbols

For the purposes of the present document, the following symbols apply:

α	Filter roll-off factor
dB	decibel
dBm	dB relative to 1 mW
dB μ V	dB relative to 1 μ V
f_c	channel centre frequency
f_{LO}	Local Oscillator frequency
f_{rb}	the frequency offset corresponding to the near edge of the receive band
M1, M2, etc.	names of test signals defined in clause 6.3
PR	rms power
PX	maximum Power (Peak Envelope Power)
V_{min}	minimum extreme test Voltage
V_{max}	maximum extreme test Voltage
T_{min}	minimum extreme test Temperature
T_{max}	maximum extreme test Temperature
λ	wavelength

3.3 Abbreviations

For the purposes of the present document, the following abbreviations apply:

ac	alternating current
ACP	Adjacent Channel Power
ARQ	Automatic Repeat reQuest
BS	Base Station
BW	BandWidth
CBW	Channel BandWidth
CEPT	European Conference of Postal and Telecommunications Administrations
CSP	Channel SeParation
CW	Continuous Wave
dBc	decibels relative to the transmitter power
dc	direct current

EC	European Community
EFTA	European Free Trade Association
EUT	Equipment Under Test
GMSK	Gaussian Minimum Shift Keying
IF	Intermediate Frequency
ITU-R	International Telecommunication Union - Radiocommunication Standardisation Sector
ITU-T	International Telecommunication Union - Telecommunication Standardisation Sector
LBT	Listen Before Transmit
MBW	Measurement BandWidth
MS	Mobile Station
OATS	Open Area Test Site
PEP	Peak Envelope Power
PMR	Private Mobile Radio
ppm	parts per million
RF	Radio Frequency
rms	root mean square
RSSI	Received Signal Strength Indicator
Rx	Receiver
TETRA	TErrestrial Trunked RAdio
TMO	Trunked Mode Operation
Tx	Transmitter
VSWR	Voltage Standing Wave Ratio
$\pi/4$ -DQPSK	$\pi/4$ -shifted Differential Quaternary Phase Shift Keying

4 General

4.1 Testing

4.1.1 Choice of model for testing

4.1.1.0 General

The supplier shall provide one or more samples of the equipment, as appropriate for testing. Stand-alone equipment shall be complete with any ancillary equipment needed for testing.

If an equipment has several optional features, considered not to affect the RF parameters, then the tests need only be performed on the equipment configured with the combination of features considered to be the most complex. Where practicable, equipment to be tested shall provide a 50 Ω connector for conducted RF power level measurements.

In the case of integral antenna equipment, if the equipment does not have an internal permanent 50 Ω connector then it is permissible to use a second sample of the equipment with a temporary antenna connector fitted to facilitate testing. Any such modified sample shall not be used for any radiated measurements, except as noted in clause 5.5.3.

The performance of the equipment to be tested shall be representative of the performance of the corresponding production model.

4.1.1.1 Auxiliary test equipment

All necessary test signal sources, setting up instructions and other product information shall be made available with the equipment to be tested.

4.1.1.2 Declarations by the supplier

The supplier shall declare the necessary information about the equipment with respect to all technical requirements set by the present document.

4.1.2 Presentation of equipment for testing purposes

The radio tests shall be performed on the lowest, the highest and the middle radio frequency channels of either the transmit or receive band of the equipment, whichever is appropriate.

The supplier shall declare the frequency ranges, the range of operating conditions and power requirements as applicable, to establish the appropriate test conditions. For non TMO repeater equipment information related to radio sub-system of equipment includes the transmit and receive frequency bands, first local oscillator frequency and intermediate frequencies of the receiver.

Additionally, technical documentation and operating manuals, sufficient to make the test, shall be supplied. All necessary setting up instructions and other product information shall be made available with the equipment to be tested, in accordance with article 10.8 of Directive 2014/53/EU [i.3].

For TMO Repeater Equipment supplier declarations shall include:

- a) the operating band or bands of the repeater;
- b) the maximum rated output power per channel;
- c) the number of channels supported by the repeater.

Guidance on the presentation of equipment is also given in ETSI EN 300 793 [i.10].

4.2 Mechanical and electrical design

4.2.1 General

The equipment should be designed, constructed and manufactured in accordance with good engineering practice, and with the aim of minimizing harmful interference to other equipment and services.

4.2.2 Controls

Those controls, which if maladjusted, might increase the interfering potentialities of the equipment shall not be accessible for adjustment by the user.

4.2.3 Transmitter shut-off facility

When a timer for an automatic shut-off facility is operative, at the moment of the time-out the transmitter shall automatically be switched off (the re-activation of the transmitter shall reset the timer).

A shut-off facility shall be inoperative for the duration of the measurements unless it has to remain operative to protect the equipment. If the shut-off facility is left operative the status of the equipment shall be indicated.

4.3 Marking

The equipment shall be marked in a visible place. This marking should be legible, tamperproof and durable.

The marking shall be in accordance with EC Directives and/or CEPT decisions or recommendations as appropriate.

4.4 Testing using bit streams or messages

The supplier may elect to have the equipment tested using bit streams or messages. It should be noted that the methods of measurement using messages are usually more time consuming.

4.5 Measuring continuous mode equipment

In the case of measurements performed on equipment designed to operate only in continuous mode, requirements such as "equipment shall be set in continuous mode" shall be interpreted as "equipment shall be used in its normal transmission mode (in this case, the continuous mode)".

4.6 Measuring discontinuous mode equipment

When it is specified that the transmission shall be continuous for the duration of the measurement(s), the transmitter under test shall be set to operate in continuous mode. If this is not possible, the measurements shall be carried out in a period shorter than the duration of the transmitted burst. It may be necessary to extend the duration of the burst.

When measurements are made in discontinuous mode, the reported values can be average values. This averaging shall be made using a set of measurements, each of these measurements being made during a burst or a part of it.

4.7 Constant and non-constant envelope modulation

Constant envelope angle modulation systems may be measured following the measurement procedure either for constant envelope angle modulation equipment or for non-constant envelope modulation equipment.

Non-constant envelope modulation systems shall always be measured following the measurement procedure for non-constant envelope modulation equipment.

NOTE: Both modulation types may be continuous or non-continuous.

In both cases, the type of measurement procedure used shall be reported in the test report.

4.8 Multi-Mode equipment

In the case of equipment supporting more than one channel bandwidth, measurements shall be performed on each channel bandwidth implemented.

4.9 Environmental profile

The technical requirements of the present document apply under the environmental profile for operation of the equipment, which shall be declared by the supplier, but as a minimum, shall be that specified in the test conditions contained in the present document.

5 Test conditions, power sources and ambient temperatures

5.1 Normal and extreme test conditions

Testing shall be performed under normal test conditions, and also, where stated, under extreme test conditions.

The test conditions and procedures shall be as specified in clauses 5.2 to 5.5.

5.2 Test power source

During testing the power source of the equipment shall be replaced by a test power source capable of producing normal and extreme test voltages as specified in clauses 5.3.2 and 5.4.2. The internal impedance of the test power source shall be low enough for its effect on the test results to be negligible. For the purpose of tests, the voltage of the power source shall be measured at the input terminals of the equipment.

For battery operated equipment the battery shall be removed and the test power source shall be applied as close to the battery terminals as practicable.

During tests of dc powered equipment the power source voltages shall be maintained within a tolerance of $< \pm 1$ % relative to the voltage at the beginning of each test. The value of this tolerance is critical for power measurements. Using a smaller tolerance will provide better measurement uncertainty values.

5.3 Normal test conditions

5.3.1 Normal temperature and humidity

The normal temperature and humidity conditions for tests shall be any convenient combination of temperature and humidity within the following ranges:

- temperature: +15 °C to +35 °C;
- relative humidity: 20 % to 75 %.

When it is impracticable to carry out the tests under these conditions, a note to this effect, stating the ambient temperature and relative humidity during the tests, shall be added to the test report.

5.3.2 Normal test power source

5.3.2.1 Mains voltage

The normal test voltage for equipment to be connected to the mains shall be the nominal mains voltage. For the purpose of the present document, the nominal voltage shall be the declared voltage or any of the declared voltages for which the equipment was designed.

The frequency of the test power source corresponding to the ac mains shall be between 49 Hz and 51 Hz.

5.3.2.2 Regulated lead-acid battery power sources used on vehicles

When the radio equipment is intended for operation from the usual types of regulated lead-acid battery power source used on vehicles the normal test voltage shall be 1,1 times the nominal voltage of the battery (for nominal voltages of 6 V and 12 V, these are 6,6 V and 13,2 V respectively).

5.3.2.3 Other power sources

For operation from other power sources or types of battery (primary or secondary), the normal test voltage shall be that declared by the equipment supplier.

5.4 Extreme test conditions

5.4.1 Extreme temperatures

For tests at extreme temperatures, measurements shall be made in accordance with the procedures specified in clause 5.5, at the upper and lower temperatures shall be as follows:

- the lower temperature shall be -20 °C except for BS and TMO repeater equipment where the lowest intended operational temperature of the BS/repeater shall apply if this is higher than -20 °C;
- the upper temperature shall be +55 °C except for BS and TMO repeater equipment where the highest intended operational temperature of the BS/repeater shall apply if this is lower than +55 °C.

In the case of base stations and TMO repeater equipment, the manufacturer shall declare the conditions the equipment is intended to be installed in.

5.4.2 Extreme test source voltages

5.4.2.1 Mains voltage

The extreme test voltage for equipment to be connected to an ac mains source shall be the nominal mains voltage $\pm 10\%$.

5.4.2.2 Regulated lead-acid battery power sources used on vehicles

When the equipment is intended for operation from the usual types of regulated lead-acid battery power sources used on vehicles the extreme test voltages shall be 1,3 and 0,9 times the nominal voltage of the battery (for a nominal voltage of 6 V, these are 7,8 V and 5,4 V respectively and for a nominal voltage of 12 V, these are 15,6 V and 10,8 V respectively).

5.4.2.3 Power sources using other types of batteries

The lower extreme test voltages for equipment with power sources using batteries shall be as follows:

- for the nickel metal-hydrate, leclanché or lithium type: 0,85 times the nominal battery voltage;
- for the mercury or nickel-cadmium type: 0,9 times the nominal battery voltage.

No upper extreme test voltages apply.

In the case where no upper extreme test voltage is applicable, the corresponding four extreme test conditions are:

- V_{\min}/T_{\min} , V_{\min}/T_{\max} ;
- $(V_{\max} = \text{nominal})/T_{\min}$, $(V_{\max} = \text{nominal})/T_{\max}$.

5.4.2.4 Other power sources

For equipment using other power sources, or capable of being operated from a variety of power sources, the extreme test voltages shall be those declared by the equipment supplier.

5.5 Procedure for tests at extreme temperatures

5.5.0 Thermal balance

Before measurements are made the equipment shall have reached thermal balance in the test chamber. The equipment shall be switched off during the temperature stabilizing period.

In the case of equipment containing temperature stabilization circuits designed to operate continuously, the temperature stabilization circuits may be switched on for 15 minutes after thermal balance has been obtained, and the equipment shall then meet the specified requirements. For such equipment the supplier shall provide for the power source circuit feeding the crystal oven (if any) to be independent of the power source for the rest of the equipment.

If the thermal balance is not checked by measurements, a temperature stabilizing period of at least one hour, or a longer period as may be decided by the testing laboratory, shall be allowed. The sequence of measurements shall be chosen, and the humidity content in the test chamber shall be controlled so that excessive condensation does not occur.

5.5.1 Procedure for equipment designed for continuous transmission

If the supplier states that the equipment is designed for continuous transmission, the test procedure shall be as follows.

- Before tests at the upper extreme temperature, the equipment shall be placed in the test chamber, and left until thermal balance is attained. The equipment shall then be switched on in the transmit condition with modulation M1 or M2 (as appropriate, see clause 6.3.1), for a period of half an hour, after which the equipment shall meet the specified requirements.
- Before tests at the lower extreme temperature, the equipment shall be left in the test chamber until thermal balance is attained, then switched to the standby or receive condition for a period of one minute, after which the equipment shall meet the specified requirements.

5.5.2 Procedure for equipment designed for intermittent transmission

If the supplier states that the equipment is designed for intermittent transmission, the test procedure shall be as follows.

- Before tests at the upper extreme temperature, the equipment shall be placed in the test chamber, and left until thermal balance is attained. The equipment shall then be switched on for one minute in the transmit condition with modulation M1 or M2 (as appropriate, see clause 6.3.1), followed by four minutes in the receive condition, after which the equipment shall meet the specified requirements.
- For tests at the lower extreme temperature, the equipment shall be left in the test chamber until thermal balance is attained, then switched to the standby or receive condition for one minute, after which the equipment shall meet the specified requirements.

5.5.3 Testing of equipment that does not have an external 50 Ω RF connector (integral antenna equipment)

Where equipment has an internal 50 Ω connector it shall be permitted to perform the tests at this connector.

Equipment may also have a temporary internal 50 Ω connector installed for the purposes of testing.

No connection shall be made to any internal permanent or temporary antenna connector during the performance of radiated emissions measurements, unless such action forms an essential part of the normal intended operation of the equipment, as declared by the supplier.

6 General conditions of measurement

6.1 Arrangements for test signals applied to the receiver input

Sources of test signals for application to the receiver input shall be connected in such a way that the source impedance presented to the receiver input is 50 Ω (clause 6.6).

This requirement shall be met irrespective of whether one or more signals using a combining network are applied to the receiver.

The effects of any intermodulation products and noise produced in the test signal sources should be negligible.

6.2 Test load (artificial antenna)

For conducted measurements of the transmitter, a power attenuator ("artificial antenna") shall be used, exhibiting a substantially non-reactive, non-radiating load of 50 Ω to the antenna connector and capable of dissipating the transmitter output power.

6.3 Test signals (wanted and unwanted signals)

6.3.0 General

The supplier shall declare details of the modulation scheme used.

6.3.1 Transmitter test signals

The supplier shall declare details of the modulation scheme used. This shall be considered the normal modulation of the equipment.

Test signal M1 shall consist of a pseudo-random bit sequence of at least 511 bits (according to Recommendation ITU-T O.153 [1]), at the appropriate data rate.

If the transmission of a continuous bit stream is not possible, test signal M2 shall be trains of correctly coded bits or messages. An encoder of the type defined in clause 6.4.2 may be used.

For the purpose of testing PX in clause 7.1 test signals M1 and M2 should produce the largest value of output power (PEP) possible. If this is not the case then a test signal that does produce the largest possible value of output power (PEP) shall be used in the testing in clause 7.1.

For equipment that supports adaptive rates, testing is only required at one bit rate. For transmitter tests in clause 7 this would normally be the highest bit-rate supported by the equipment.

Suppliers shall declare where any of the specific tests in clause 7, if conducted at rates other than the highest bit rate, are likely to give results which are worse than at the highest bit rate. In such cases the tests shall be carried out at the rate declared by the supplier that is likely to give the worst performance (least margin between measured results and test limits).

The test signal T2 is a $\pi/4$ -DQPSK modulated continuous radio signal following the structure of TETRA signals, but with all modulating bits (including training sequences) derived directly from pseudo random bit sequence (with a length of 511 bits according to Recommendation ITU-T O.153 [1]).

6.3.2 Receiver test signals

The normal test signals shall be generated using a method as declared by the equipment supplier and shall be as follows:

- signal M3, consisting of a RF carrying a pseudo-random bit sequence of at least 511 bits (according to Recommendation ITU-T O.153 [1]);
- if the transmission of a continuous bit stream is not possible, test signal M4 shall be trains of correctly coded bits or messages using an encoder as defined in clause 6.4.2.

For interferer tests signal shall be as follows:

- Receiver test signal M5 consisting of a RF carrying a pseudo-random bit sequence of at least 511 bits (according to Recommendation ITU-T O.153 [1]) modulated with $\pi/4$ -DQPSK modulation as defined in ETSI EN 300 392-2 [5] at a rate of 18 ksymbols/s.
- Co-channel test signal M6 consisting of a RF carrying a pseudo-random bit sequence of at least 511 bits (according to Recommendation ITU-T O.153 [1]) modulated with $\pi/4$ -DQPSK modulation as defined in ETSI TR 100 028 [2] at a rate of:
 - 18 ksymbols/s for 25 kHz Channel Bandwidth (Signal M6-25);
 - 36 ksymbols/s for 50 kHz Channel Bandwidth (Signal M6-50);
 - 70 ksymbols/s for 100 kHz Channel Bandwidth (Signal M6-100);
 - 104 ksymbols/s for 150 kHz Channel Bandwidth (Signal M6-150).

6.3.3 Transmitter effective radiated power test signal (C1)

Test signal C1 shall be any signal that provides a constant envelope of output power at the output of the transmitter. This may be a CW tone or a modulated signal with constant envelope (e.g. GMSK). The envelope shall be flat to ± 1 dB.

If the equipment under test is capable of operating in non-constant envelope modes, or at higher powers than with test signal C1, the ratio, in dB, between the mean power obtained with test signal C1 and the maximum PEP for any modulating signal accepted by the transmitter shall be known as the CW-to-PEP correction factor for signal C1.

6.4 Encoder

6.4.1 Encoder for receiver measurements

Whenever needed, and in order to facilitate measurements on the receiver, an encoder for the data system is expected to accompany the equipment to be measured, together with details of the normal modulation process. The encoder is used to modulate a signal generator for use as a test signal source.

In the case of equipment unable to operate with continuous bit streams, the encoder shall be capable of operation in a repetitive mode, with intervals between each message that are not less than the reset time of the receiver.

NOTE: If the reset time of the receiver is 0 (zero) seconds then this is equivalent to continuous transmission of data in packetized format.

Complete details of all codes and code format(s) used shall be made available for the measurements.

Where equipment normally uses an ARQ process the supplier can substitute alternative test methods as long as they are considered equivalent to the relevant receiver measurement. In this case details of the test procedure used shall be recorded.

6.4.2 Encoder for transmitter measurements

It is permissible to use an encoder to provide coded data from a pseudo-random bit sequence of at least 511 bits (according to Recommendation ITU-T O.153 [1]). Whenever a transmitter is not rated for continuous operation, the coded data may be transmitted in a discontinuous manner following as closely as possible the normal transmission characteristics of the EUT.

6.5 Transceiver data interface

Equipment that does not integrate the keyboard and display used for normal operation shall either provide a standardized interface (preferably) or other suitable (proprietary) interfaces.

In the case where the equipment uses a proprietary interface, appropriate means and documentation allowing for the equipment to be tested are expected to be provided with the measurements.

Variation in the level of the input signals, within the specified limits for that interface, shall have no measurable influence on the characteristics of the signals on the radio path.

6.6 Impedance

In the present document the term "50 Ω" is used for a 50 Ω non-reactive impedance.

6.7 PEP

The PEP is the average power supplied to the artificial antenna by a transmitter during one RF cycle at the highest crest of the modulation envelope.

6.8 Duplex equipment

If the equipment is provided with a built-in duplex filter or with a separate associated filter, the requirements of the present document shall be met when the measurements are carried out using the antenna connector of the filter.

Duplex equipment having integral antenna may be tested using the internal or temporary antenna connector.

6.9 Modes of operation of the transmitter

Measurements shall be made with the transmitter being modulated representative of normal operation.

If the equipment is fitted with an automatic transmitter shut-off facility it shall be made inoperative for the duration of the type test, unless it has to be left operative to protect the equipment.

The characteristics (continuous or discontinuous transmission, burst duration) of the transmission modes used for each of the following measurements shall be stated in the test report.

6.10 Measurement filter definition

The measurement filter shall be a linear phase filter which is defined by the magnitude of its frequency response:

$$|H(f)| = G(f).$$

$$G(f) = 1 \quad \text{for} \quad |f| \leq (1 - \alpha)/2T$$

$$G(f) = \sqrt{0.5 \left(1 - \sin \left(\pi (2|f|T - 1) / 2\alpha \right) \right)} \quad \text{for} \quad (1 - \alpha)/2T \leq |f| \leq (1 + \alpha)/2T$$

$$G(f) = 0 \quad \text{for} \quad |f| \geq (1 + \alpha)/2T$$

Where:

- T is the symbol duration;
- α is the roll-off factor, which determines the width of the filter band at a given symbol rate.

The value of α shall be 0,35. The symbol rate shall be 18 000 symbols per second.

6.11 TMO Repeaters

A repeater can be designed to amplify the whole transmit RF band or just a part of the band. In the latter case the repeater can be either broadband, with frequency band selective filtering, or channelized, with channel selective filtering.

For TMO Repeater equipment the following conditions shall apply:

- the equipment shall be operated at maximum gain unless otherwise specified;
- measurements apply to both the uplink and downlink direction of the repeater;
- as appropriate for the transmitter tests, the relevant antenna input port of the repeater shall be connected to a RF signal generator which shall excite the repeater with a continuous RF signal modulated with test signal M1 or M2 as appropriate; the input level to the repeater shall be increased, until the maximum rated output power per channel is reached.

Information and background on test methods and configuration of this type of equipment can be found in ETSI TS 101 789-1 [i.4] with further relevant information available in ETSI EN 300 394-1 [i.5] and ETSI EN 303 035-1 [i.6].

7 Technical characteristics of the transmitter

7.1 Transmitter output power (conducted)

7.1.0 General

This measurement applies only to equipment with an external 50 Ω antenna connector.

7.1.1 Definitions

The PX of the transmitter is the maximum value of the output PEP for any condition of modulation.

The rated maximum power of the transmitter is that declared by the supplier.

7.1.2 Method of measurement

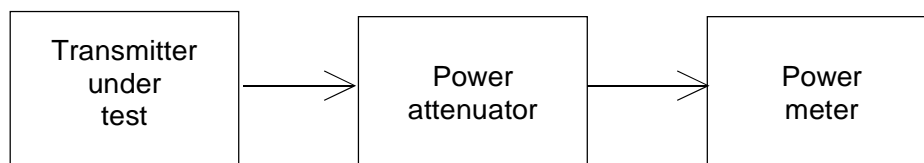

Figure 1: Measurement arrangement

The measurement shall be performed with test signal M1 or M2 (as appropriate, see clause 6.3.1) applied at the transmitter. The modulation used shall be recorded in the test report.

The transmitter shall be set in continuous transmission mode. If this is not possible, the measurements shall be carried out in a period shorter than the duration of the transmitted burst. If the output power of the transmitter is adjustable the maximum output level shall be selected.

The transmitter shall be connected to a 50 Ω power attenuator, and the PEP delivered shall be measured. The measuring instrument shall have a measurement bandwidth not less than sixteen times the CBW or 1 MHz, whichever is the smaller.

The power measured is recorded as the value PX.

For TMO repeater the measurements shall be performed in both the uplink and downlink direction, at maximum and minimum gain and on channels at the upper and lower limits of operational frequency band of the repeater, as declared by the supplier.

The measurement shall be made under normal test conditions (see clause 5.3) and extreme test conditions (see clauses 5.4.1 and 5.4.2).

7.1.3 Limits

The measured PX under normal test conditions shall be within $\pm 2,0$ dB of the rated transmitter power (conducted).

The measured PX under extreme test conditions shall be within +3,0 dB and -4,0 dB of the rated output power.

It is assumed that the appropriate National Administration will state the maximum permitted transmitter output power.

7.2 Maximum effective radiated power

7.2.0 General

This measurement applies only for equipment without an external 50 Ω antenna connector.

7.2.1 Definition

The maximum effective radiated power of the transmitter is the maximum value of the output PEP for any condition of modulation radiated in the direction of the maximum field strength by the equipment with its integral antenna fitted. The rated maximum effective radiated power is that declared by the supplier.

7.2.2 Method of measurement

7.2.2.1 Evaluation of CW-to-PEP correction factor for signal C1

The measurement shall be carried out under normal conditions only.

The transmitter permanent internal or a temporary internal 50 Ω RF connector shall be connected to a 50 Ω power attenuator. The transmitter shall be switched on with test signal C1 (see clause 6.3.3) applied and the PEP delivered shall be measured. The measuring instrument shall have a measurement bandwidth not less than sixteen times the CBW or 1 MHz, whichever is the smaller. The mean power delivered shall also be measured. The difference between the PEP and the mean power shall be less than 1 dB.

The value of PX, from the antenna connector, shall be measured according to the method in clause 7.1.2.

The difference (in dB) between PX and the mean power measured for C1 modulation shall be recorded. This value is the CW-to-PEP correction factor for signal C1.

7.2.2.2 Measurements on a test site

The measurement shall be carried out under normal conditions only.

On a test site, selected from annex B, the equipment and its antenna shall be mounted in a normal installation in its normal operating position, shall be placed at the specified height on a non-conducting support, in the position closest to normal use as declared by the supplier. This position shall be recorded in the test report.

The test antenna shall be orientated for vertical polarization and the length of the test antenna shall be chosen to correspond to the frequency of the transmitter.

The output of the test antenna shall be connected to a measuring receiver.

The transmitter shall be switched on with test signal C1 (see clause 6.3.3) applied and the measuring receiver shall be tuned to the centre frequency of the channel on which the transmitter is intended to operate.

The test antenna shall be raised and lowered through the specified range of height until a maximum signal level is detected on the measuring receiver.

When a test site according to clause B.1.1 is used there is no need to vary the height of the antenna.

The transmitter shall then be rotated through 360° in the horizontal plane until the maximum signal level is detected by the measuring receiver.

The maximum signal level detected by the measuring receiver shall be noted.

The transmitter shall be replaced by a substitution antenna as defined in clause B.1.5.

The substitution antenna shall be orientated for vertical polarization and the length of the substitution antenna shall be adjusted to correspond to the frequency of the transmitter.

The substitution antenna shall be connected to a calibrated signal generator.

The sensitivity of the measuring receiver shall be increased in accordance with the new input level (change in attenuator setting).

The test antenna shall be raised and lowered through the specified range of height to ensure that the maximum signal is received. When a test site according to clause B.1.1 is used there is no need to vary the height of the antenna.

The input signal to the substitution antenna shall be adjusted to a level that produces the level detected by the measuring receiver, that is equal to the level noted while using the transmitter under test, corrected for the change in the attenuator setting in the measuring receiver.

The input level to the substitution antenna shall be recorded as a power level.

The measurement shall be repeated with the test antenna and the substitution antenna orientated for horizontal polarization.

The measure of the maximum effective radiated power is the larger of the two power levels recorded at the input to the substitution antenna, corrected for the gain of the antenna if necessary.

The maximum effective radiated PEP is the effective radiated power corrected by the CW-to-PEP correction factor for signal C1, as measured in clause 7.2.2.1.

7.2.3 Limit

The maximum effective radiated power under normal test conditions shall be within d_f from the rated effective radiated power.

The allowance for the characteristics of the equipment ($\pm 2,0$ dB) shall be combined with the actual measurement uncertainty in order to provide d_f , as follows:

$$- \quad d_f^2 = d_m^2 + d_e^2;$$

where:

- d_m is the actual measurement uncertainty;
- d_e is the allowance for the equipment (2,0 dB);
- d_f is the final difference.

All values shall be expressed in linear terms.

In all cases the actual measurement uncertainty shall comply with clause 10.

Furthermore, the maximum effective radiated power shall not exceed the maximum value allowed by the administrations.

Example of the calculation of d_f :

- $d_m = 6$ dB (value acceptable, as indicated in the table of maximum uncertainties);
= 3,98 in linear terms;
- $d_e = 2,0$ dB (fixed value for all equipment fulfilling the requirements of the present document);
= 1,58 in linear terms;

- $d_f^2 = (3,98)^2 + (1,58)^2$; therefore;
- $d_f = 4,28$ in linear terms, or 6,31 dB.

This calculation shows that in this case d_f is in excess by 0,31 dB compared to d_m , the actual measurement uncertainty (6 dB).

7.3 Adjacent and alternate channel power

7.3.1 Definition

The adjacent channel power is that part of the total output power of a transmitter, under defined conditions of modulation, which falls within specified passbands centred on the nominal frequency of either of the adjacent channels.

The alternate channel power is that part of the total output power of a transmitter, under defined conditions of modulation, which falls within specified passbands centred on the nominal frequency of either of the alternate channels.

These powers are the sum of the rms powers produced by the modulation, hum and noise of the transmitter.

The adjacent and alternate channels are defined as having channel bandwidths of 25 kHz, the specified passband of which is equal to the bandwidth of a square root raised cosine filter given in clause 6.10. The adjacent, alternate and wanted channels are depicted in figure 2.

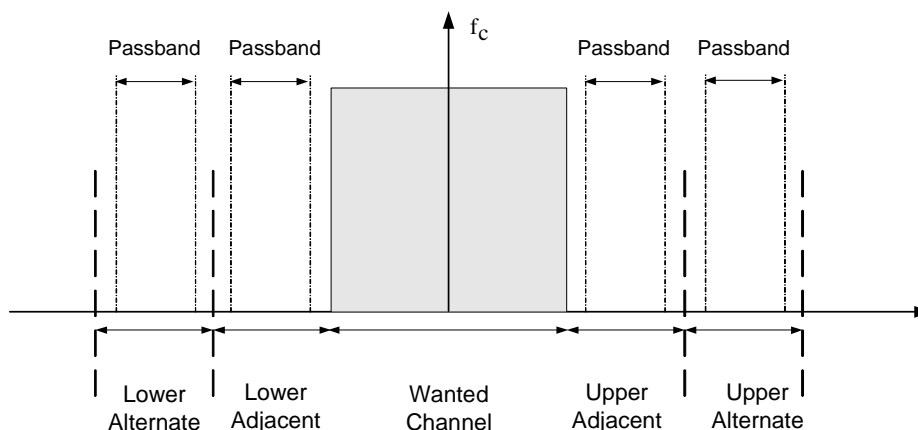

NOTE: This measurement is complemented by adjacent channel transient power measurements.

Figure 2: Adjacent and alternate channel definitions

7.3.2 Method of measurement

The adjacent and alternate channel powers shall be measured with a spectrum analyser, or equivalent measurement instrument, which conforms with the requirements given in annex C.

The transmitter shall be operated at the value of PX determined under normal test conditions.

The transmitter shall be modulated with test signal M1 or M2 as appropriate. The modulation used shall be recorded in the test report.

The transmitter shall be set in continuous transmission mode. If this is not possible, the measurements shall be carried out in a period shorter than the duration of the transmitted burst.

The output of the transmitter shall be connected to the input of the spectrum analyser by a 50 Ω power attenuator, to ensure that the impedance presented to the transmitter is 50 Ω and the level at the spectrum analyser input is appropriate.

The resolution bandwidth of the spectrum analyser shall be 1 000 Hz.

The rms power present in the nominal channel, measured on the spectrum analyser, shall be recorded (the wanted channel power, PR).

For the purpose of the remainder of this test the measurement bandwidth (MBW) shall be equal to the specified passband of the adjacent and alternate channels (clause 7.3.1) or if a spectrum analyser is used a power measuring bandwidth of 18 kHz shall be used.

The MBW shall be centred 12,5 kHz above the edge of the nominal channel. The rms power present in the MBW shall be recorded (the adjacent channel power).

The measurement shall be repeated with the MBW centred 12,5 kHz below the edge of the nominal channel.

The measurement shall be made under normal test conditions (see clause 5.3) and repeated under extreme test conditions (clauses 5.4.1 and 5.4.2 applied simultaneously).

Measurement under extreme conditions (see clause 5.4) may be omitted if the equipment is capable of testing for frequency error and such tests are carried out under clause 7.7.

The adjacent channel power ratio is the difference (in dB) between the measured wanted channel power (PR) under normal test conditions and the largest adjacent channel power. Where tests are conducted under normal and extreme test conditions, this results in two values for the adjacent channel power ratio.

Alternatively, if the spectrum analyser measures rms adjacent channel power automatically, the adjacent channel power (in dB) may be measured directly at normal and extreme test conditions. The analyser should use an analogue measurement method without frequency weighting and not using an accelerated method. The adjacent channel power ratio is the smaller of the measurement results from the two channels above and below the wanted.

The measurement shall be repeated with the MBW centred 37,5 kHz above the edge of the nominal channel. The rms power present in the MBW shall be recorded (the alternate channel power). The measurement shall be repeated with the MBW centred 37,5 kHz below the edge of the nominal channel. The measurement shall be made under normal test conditions (see clause 5.3) and repeated under extreme test conditions (see clauses 5.4.1 and 5.4.2 applied simultaneously). Automatic measurement may also be used if supported by the spectrum analyser.

Measurement under extreme conditions (see clause 5.4) may be omitted if the equipment is capable of testing for frequency error and such tests are carried out under clause 7.7.

The alternate channel power ratio is the difference (in dB) between the measured integrated wanted channel power under normal test conditions and the largest alternate channel power from the two channels above and below the wanted. Where tests are conducted under normal and extreme test conditions, this results in two values for the alternate channel power ratio.

Table 2: Summary of measurement offset

	25 kHz Channels	50 kHz Channels	100 kHz Channels	150 kHz Channels
Nominal Channel Bandwidth (for measurement of PR)	25 kHz	50 kHz	100 kHz	150 kHz
Centre of Adjacent Channel (relative to centre of the nominal channel)	±25 kHz	±37,5 kHz	±62,5 kHz	±87,5 kHz
Centre of Alternate Channel (relative to centre of the nominal channel)	±50 kHz	±62,5 kHz	±87,5 kHz	±112,5 kHz

For TMO Repeater equipment this test shall be performed in both the uplink and downlink direction at the centre of the repeaters operating band.

7.3.3 Limits

7.3.3.1 Limits for TMO Repeaters

The limits detailed in the following table 2a shall not be exceeded for adjacent channel power.

Table 2a: Maximum adjacent power for TMO repeater equipment

Frequency offset	Maximum Level at normal test conditions	Maximum Level at extreme test conditions
Adjacent channel	60 dBc	50 dBc
Alternate channel	70 dBc	60 dBc
Second alternate channel	70 dBc	60 dBc

At no offset shall the level of ACP need to be below 0,2 μ W (-36 dBm), under both normal and extreme conditions.

7.3.3.2 Limits for all non TMO repeater equipment

The limits detailed in the following table 2b shall not be exceeded for adjacent channel power.

Table 2b: Maximum adjacent power for non-TMO repeater equipment

Frequency offset	Maximum Level at normal test conditions	Maximum Level at extreme test conditions
Adjacent channel	55 dBc	50 dBc
Alternate channel	60 dBc	55 dBc

At no offset shall the level of ACP need to be below 0,2 μ W (-37 dBm), under both normal and extreme conditions. Limits under extreme conditions (see clause 5.4) are not applicable if the equipment is capable of being tested for frequency error and such tests are carried out under clause 7.7.

7.4 Unwanted emissions in the spurious domain

7.4.1 Definition

Spurious emissions are emissions on a frequency, or frequencies, which are outside the necessary bandwidth and the level of which may be reduced without affecting the corresponding transmission of information. Spurious emissions include harmonic emissions, parasitic emissions, intermodulation products and frequency conversion products but exclude out of band emissions. For the purpose of the present document the transition point between spurious domain and the out of band domain is taken as 250 % of the CSP (see Recommendation ITU-R SM.329-12 [i.1]).

For TMO Repeater equipment this test shall be performed in both the uplink and downlink direction at the centre of the repeaters operating band.

For TMO Repeater equipment the measurements shall be performed for frequency offsets from the carrier frequency greater than 600 kHz under the following two conditions:

- i) Without any RF input signal. The relevant input antenna port of the repeater shall be terminated with 50 Ω .
- ii) With a continuous sinusoidal RF input signal at the centre of the repeaters operating band.

For TMO Repeater the Tx Standby function is not applicable.

7.4.2 Method of measuring the power level

7.4.2.1 Measurement options

The level of spurious emissions shall be considered to be either:

- a) their power level in a specified load (conducted spurious emission); and
- b) their effective radiated power when radiated by the cabinet and structure of the equipment (cabinet radiation);
or
- c) their effective radiated power when radiated by the cabinet and by the integral antenna, in the case of hand portable equipment fitted with such an antenna and no external RF connector.

NOTE: There only two options allowed either both a) and b) or only c).

In addition equipment shall be specifically measured for wideband noise.

7.4.2.2 Method of measuring conducted spurious emissions (clause 7.4.2.1 a))

This method applies only to equipment with an external 50 Ω antenna connector.

Spurious emissions shall be measured as the mean power level of any signal delivered into a 50 Ω load. This may be done by connecting the transmitter output through an attenuator to either a spectrum analyser (see also annex C) or selective voltmeter or by monitoring the relative levels of the spurious signals delivered to an artificial antenna (see clause 6.2).

The transmitter shall be modulated with the test signal M1 or M2 (as appropriate, see clause 6.3.1). If possible, the modulation should be continuous for the duration of the measurement. For non TMO repeater equipment measurements made over the frequency range 30 MHz to 4 GHz. For TMO repeater equipment measurements made over the frequency range 9 kHz to 4 GHz. For equipment operating on frequencies above 470 MHz the measurements shall also be performed over the frequency range 4 GHz to 12,75 GHz if emissions are detected within 10 dB of the specified limit between 1,5 GHz and 4 GHz.

The measurements shall be performed excluding the five contiguous channels centred on the channel on which the transmitter is intended to operate.

As a general rule, the resolution bandwidth of the measuring receiver should be equal to the reference bandwidth as given in clause 7.4.3 (see note). The bandwidth used in this measurement for each spurious emission shall be sufficiently narrow to reject emissions in the five contiguous channels centred on the channel on which the transmitter is intended to operate.

For non TMO repeater equipment the measurement shall be repeated with the transmitter in the "stand-by" position.

NOTE: *"To improve measurement accuracy, sensitivity and efficiency, the resolution bandwidth can be different from the reference bandwidth. When the resolution bandwidth is smaller than the reference bandwidth, the result should be integrated over the reference bandwidth. When the resolution bandwidth is greater than the reference bandwidth, the result for broadband spurious emissions should be normalized to the bandwidth ratio. For discrete spur, normalization is not applicable, while integration over the reference bandwidth is still applicable."* (extract from CEPT/ERC/REC 74-01 [i.2], recommend 4, page 5).

7.4.2.3 Method of measuring the effective radiated power (clause 7.4.2.1 b))

This method applies only to equipment with an external antenna connector.

On a test site, selected from annex B, the equipment shall be placed at the specified height on a non-conducting support and in the position closest to normal use as declared by the supplier.

The transmitter antenna connector shall be connected to an artificial antenna (see clause 6.2).

The output of the test antenna shall be connected to a measuring receiver.

The test antenna shall be orientated for vertical polarization and the length of the test antenna shall be chosen to correspond to the frequency of the measuring receiver.

The transmitter shall be switched on with C1 modulation, and the measuring receiver shall be tuned over the frequency range 30 MHz to 4 GHz, except for the five contiguous channels centred on the channel on which the transmitter is intended to operate. At each frequency at which a discrete spurious component is detected, the test antenna shall be raised and lowered through the specified range of heights until a maximum signal level is detected on the measuring receiver. The resolution bandwidth of the measuring instrument shall be the smallest bandwidth available which is greater than the spectral width of the spurious component being measured. This shall be considered to be achieved when the next highest bandwidth causes less than 1 dB increase in amplitude.

When a test site according to clause B.1.1 is used there is no need to vary the height of the antenna.

The transmitter shall then be rotated through 360° in the horizontal plane, until the maximum signal level is detected by the measuring receiver.

The transmitter shall be modulated by the test signal M1 or M2 (as appropriate, see clause 6.3.1). If possible, the modulation should be continuous for the duration of the measurement. When burst transmission is used, the mean power of any spurious emissions shall be measured using averaging over the duration of the burst. The measuring receiver shall measure the mean power and this power shall be noted. The horizontal and vertical orientation of the antenna shall also be noted.

The transmitter shall be replaced by a substitution antenna as defined in clause B.1.5.

The substitution antenna shall be orientated for vertical polarization and the length of the substitution antenna shall be adjusted to correspond to the frequency of the spurious component detected.

The substitution antenna shall be connected to a calibrated signal generator.

The frequency of the calibrated signal generator shall be set to the frequency of the spurious component detected.

The input attenuator setting of the measuring receiver shall be adjusted in order to increase the sensitivity of the measuring receiver, if necessary.

The test antenna shall be raised and lowered through the specified range of heights to ensure that the maximum signal is received.

When a test site according to clause B.1.1 is used there is no need to vary the height of the antenna.

The input signal to the substitution antenna shall be adjusted to the level that produced a level detected by the measuring receiver, that is equal to the level noted while the spurious component was measured, corrected for the change of input attenuator setting of the measuring receiver.

The input level to the substitution antenna shall be recorded as power level.

The measurement shall be repeated with the test antenna and the substitution antenna orientated for horizontal polarization.

The measure of the effective radiated power of the spurious components is the larger of the two power levels recorded for each spurious component at the input to the substitution antenna, corrected for the gain of the antenna if necessary.

For equipment operating on frequencies above 470 MHz the measurements shall also be performed over the frequency range 4 GHz to 12,75 GHz if emissions are detected within 10 dB of the specified limit between 1,5 GHz and 4 GHz.

As a general rule, the resolution bandwidth of the measuring receiver should be equal to the reference bandwidth as given in clause 7.4.3 (see note). The bandwidth used in this measurement for each spurious emission shall be sufficiently narrow to reject emissions in the five contiguous channels centred on the channel on which the transmitter is intended to operate.

The measurement shall be repeated with the transmitter in the "stand-by" position.

NOTE: *"To improve measurement accuracy, sensitivity and efficiency, the resolution bandwidth can be different from the reference bandwidth. When the resolution bandwidth is smaller than the reference bandwidth, the result should be integrated over the reference bandwidth. When the resolution bandwidth is greater than the reference bandwidth, the result for broadband spurious emissions should be normalized to the bandwidth ratio. For discrete spur, normalization is not applicable, while integration over the reference bandwidth is still applicable."* (extract from CEPT/ERC/REC 74-01 [i.2], recommend 4, page 5).

7.4.2.4 Method of measuring the effective radiated power (clause 7.4.2.1 c))

This method applies only to equipment without an external 50 Ω antenna connector.

The method of measurement shall be performed according to clause 7.4.2.2, except that the transmitter output shall be connected to the integral antenna and not to an artificial antenna.

7.4.2.5 Method of measuring wideband noise

This method applies to all equipment.

Spurious emissions shall be measured as the mean power level of any signal delivered into a 50 Ω load from either the permanent or temporary antenna connector, as appropriate.

For non TMO repeater equipment the transmitter shall be modulated with the test signal M1 or M2 (as appropriate, see clause 6.3.1). If possible, the modulation should be continuous for the duration of the measurement, if this is not possible, the measurements shall be carried out in a period shorter than the duration of the transmitted burst.

Wideband noise level at selected frequency offsets from the on channel shall be measured through the measurement filter, refer to clause 6.10 or if a spectrum analyser is used a power measuring bandwidth of 18 kHz shall be used. The Average power within the bandwidth shall be recorded.

The selected frequency offsets shall cover at least the frequencies indicated in table 3.

If a discrete spurious lies in one of these bands, then the closest discrete spurious free frequency with a larger frequency offset shall be chosen (frequency steps shall be in 25 kHz increments).

The measurement shall be performed at the specified offsets above and below the nominal frequency of the transmitter.

Table 3: Selected frequency offsets for wideband noise measurement

Bandwidth (kHz)	Frequency offset (kHz)
25	112,5
25	262,5
25	512,5
25	2 512,5
25	$f_{rb} + 12,5$
50	125
50	275
50	512,5
50	$f_{rb} + 12,5$
100	150
100	300
100	550
100	1 012,5
100	$f_{rb} + 12,5$
150	175
150	325
150	575
150	1 512,5
150	$f_{rb} + 12,5$

NOTE: See clause 3.2 for definition of f_{rb} .

7.4.3 Limits

7.4.3.1 Spurious emissions power

The mean power of any spurious emission, occurring more than $2,5 \times \text{CSP}$ from the centre of the channel on which the transmitter is intended to operate, shall not exceed the values given in tables 4a and 4b.

For TMO Repeater the Tx Standby function is not applicable.

Table 4a: Conducted emissions

Frequency range	9 kHz to 1 GHz	Above 1 GHz to 4 GHz, or above 1 GHz to 12,75 GHz (see clause 7.4.2.2)
Tx operating	0,25 μW (-36,0 dBm)	1,0 μW (-30,0 dBm)
Tx Standby	2,0 nW (-57,0 dBm)	20,0 nW (-47,0 dBm)

Table 4b: Radiated emissions

Frequency range	30 MHz to 1 GHz	Above 1 GHz to 4 GHz, or above 1 GHz to 12,75 GHz (see clause 7.4.2.3)
Tx operating	0,25 μ W (-36,0 dBm)	1,0 μ W (-30,0 dBm)
Tx Standby	2,0 nW (-57,0 dBm)	20,0 nW (-47,0 dBm)

Table 5a: Reference bandwidths to be used for the measurement of spurious emissions outside the frequency offsets specified for non TMO repeater equipment in table 5b (systems below 1 GHz) or table 5c (systems above 1 GHz) and for TMO repeater equipment in table 5d

Frequency range	Reference bandwidth
9 kHz to 150 kHz	1 kHz
150 kHz to 30 MHz	10 kHz
30 MHz to 1 GHz	100 kHz
1 GHz to 12,75 GHz	1 MHz

NOTE: For TMO repeater equipment excluding frequencies within frb of the carrier.

Table 5b: Reference bandwidths to be used close to the wanted emission for equipment operating below 1 GHz

Frequency offset from carrier	Reference bandwidth
250 % of the CSP to 100 kHz	1 kHz
100 kHz to 500 kHz	10 kHz

Table 5c: Reference bandwidths to be used close to the wanted emission for equipment operating above 1 GHz

Frequency offset from carrier	Reference bandwidth
250 % of the CSP to 500 kHz	30 kHz
500 kHz to 1 MHz	300 kHz

Table 5d: Reference bandwidths to be used for TMO repeater

Frequency offset from carrier	Reference bandwidth
600 kHz to TMO repeater operating band edge	1 kHz
Frequency offset from the TMO repeater operating band	Reference bandwidth
> 0 MHz	10 kHz
> 2 MHz	30 kHz
> 5 MHz	100 kHz

7.4.3.2 Wideband noise power

The wideband noise levels, measured in clause 7.4.2.5 shall not exceed the limits shown in tables 6a to 6d, for the nominal power levels (PX) as stated, and at the listed offsets from the nominal carrier frequency. When applicable, relative measurements (dBc) shall refer to the power level PR measured in clause 7.3.2. The requirements apply symmetrically to both sides of the transmitter band.

Table 6a: Wideband noise limits 25 kHz for non TMO repeater equipment

Frequency offset	Maximum wideband noise level	
	nominal power level (PX) ≤ 3 W	nominal power level (PX) > 3 W
100 kHz to 250 kHz	-70 dBc	-70 dBc
250 kHz to 500 kHz	-74 dBc	-80 dBc
500 kHz to 2 500 kHz	-80 dBc	-80 dBc
2 500 kHz to f_{rb}	-80 dBc	-90 dBc
> f_{rb}	-95 dBc	-95 dBc

NOTE: f_{rb} denotes the frequency offset corresponding to the near edge of the receive band or 5 MHz (10 MHz for frequencies above 520 MHz) whichever is greater.

Table 6b: Wideband noise limits 50 kHz for non TMO repeater equipment

Frequency offset	Maximum wideband noise level	
	Nominal power level (PX) ≤ 3 W	Nominal power level (PX) > 3 W
112,5 kHz to 262,5 kHz	-68 dBc	-70 dBc
262,5 kHz to 500 kHz	-72 dBc	-75 dBc
500 kHz to f_{rb}	-78 dBc	-80 dBc
> f_{rb}	-95 dBc	-95 dBc

NOTE: f_{rb} denotes the frequency offset corresponding to the near edge of the receive band or 5 MHz (10 MHz for frequencies above 520 MHz) whichever is greater.

Table 6c: Wideband noise limits 100 kHz for non TMO repeater equipment

Frequency offset	Maximum wideband noise level	
	Nominal power level (PX) ≤ 3 W	Nominal power level (PX) > 3 W
137,5 kHz to 287,5 kHz	-60 dBc	-70 dBc
287,5 kHz to 537,5 kHz	-65 dBc	-70 dBc
537,5 kHz to 1 000 kHz	-73 dBc	-75 dBc
1 000 kHz to f_{rb}	-73 dBc	-80 dBc
> f_{rb}	-95 dBc	-95 dBc

NOTE: f_{rb} denotes the frequency offset corresponding to the near edge of the receive band or 5 MHz (10 MHz for frequencies above 520 MHz) whichever is greater.

Table 6d: Wideband noise limits 150 kHz for non TMO repeater equipment

Frequency offset	Maximum wideband noise level	
	Nominal power level (PX) ≤ 3 W	Nominal power level (PX) > 3 W
162,5 kHz to 312,5 kHz	-60 dBc	-60 dBc
312,5 kHz to 562,5 kHz	-63 dBc	-70 dBc
562,5 kHz to 1 500 kHz	-70 dBc	-75 dBc
1 500 kHz - f_{rb}	-70 dBc	-80 dBc
> f_{rb}	-95 dBc	-95 dBc

NOTE: f_{rb} denotes the frequency offset corresponding to the near edge of the receive band or 5 MHz (10 MHz for frequencies above 520 MHz) whichever is greater.

Table 6e: Wideband noise limits 25 kHz for TMO repeater equipment

Frequency offset	Maximum wideband noise level
100 kHz to 250 kHz	-70 dBc
250 kHz to 500 kHz	-80 dBc
500 kHz - f_{rb}	-80 dBc
> f_{rb}	-95 dBc

NOTE: f_{rb} denotes the frequency offset corresponding to the near edge of the receive band or 5 MHz (10 MHz for frequencies above 520 MHz) whichever is greater.

Table 6f: Wideband noise limits 50 kHz for TMO repeater equipment

Frequency offset	Maximum wideband noise level
112,5 kHz to 262,5 kHz	-70 dBc
262,5 kHz to 500 kHz	-75 dBc
500 kHz - f_{rb}	-80 dBc
$> f_{rb}$	-95 dBc

NOTE: f_{rb} denotes the frequency offset corresponding to the near edge of the receive band or 5 MHz (10 MHz for frequencies above 520 MHz) whichever is greater.

Table 6g: Wideband noise limits 100 kHz for TMO repeater equipment

Frequency offset	Maximum wideband noise level
137,5 kHz to 287,5 kHz	-70 dBc
287,5 kHz to 537,5 kHz	-70 dBc
537,5 kHz - f_{rb}	-75 dBc
$> f_{rb}$	-95 dBc

NOTE: f_{rb} denotes the frequency offset corresponding to the near edge of the receive band or 5 MHz (10 MHz for frequencies above 520 MHz) whichever is greater.

Table 6h: Wideband noise limits 150 kHz for TMO repeater equipment

Frequency offset	Maximum wideband noise level
162,5 kHz to 312,5 kHz	-60 dBc
312,5 kHz to 562,5 kHz	-70 dBc
562,5 kHz - f_{rb}	-75 dBc
$> f_{rb}$	-95 dBc

NOTE: f_{rb} denotes the frequency offset corresponding to the near edge of the receive band or 5 MHz (10 MHz for frequencies above 520 MHz) whichever is greater.

For all levels in tables 6a to 6h, no limit tighter than -55 dBm for offsets $< f_{rb}$ or -70 dBm for offsets $> f_{rb}$ shall apply.

7.5 Intermodulation attenuation

7.5.0 Applicability

This requirement applies only to transmitters to be used in base stations or TMO repeater.

7.5.1 Definition

For the purpose of the present document the intermodulation attenuation is a measure of the capability of a transmitter to inhibit the generation of signals in its non-linear elements caused by the presence of the transmitter and an interfering signal entering the transmitter via its antenna.

7.5.2 Method of measurement

7.5.2.1 Measurement for TMO repeater equipment

Two continuous sinusoidal RF signals shall be fed to the input antenna port of the repeater using a combining device. The frequencies of both RF signals shall be within the repeater's operating band. The spacing between both RF signals shall be the minimum possible spacing supported by the equipment or 200 kHz whichever is greater. The input signals and resulting product shall be within the operating band of the repeater.

The level of both RF input signals shall be increased, until the maximum rated output power per channel is reached.

In case of a repeater only supporting one channel, one RF input signal shall be set to the operating frequency and the other RF input signal at an offset of 100 kHz to either side successively. In this case the input signal at the repeaters operating frequency shall be increased, until the maximum rated output power per channel is reached. The second signal shall be set to the same input level.

The level of the third order intermodulation products shall be measured by means of a selective measurement device presenting to the repeater a load with an impedance of $50\ \Omega$.

The test shall be repeated with both RF input signals increased by 10 dB each.

NOTE: In this case, the automatic gain (level) control may reduce the gain to a value less than maximum gain in order to keep the maximum rated output power per channel, as declared by the supplier.

An average power measurement shall be performed using a bandwidth of 3 kHz. This test shall be performed in both the uplink and downlink direction at the centre of the repeaters operating band.

The measurement shall be made under normal test conditions (see clause 5.3) and extreme test conditions (see clauses 5.4.1 and 5.4.2).

7.5.2.2 Measurement for non TMO repeater equipment

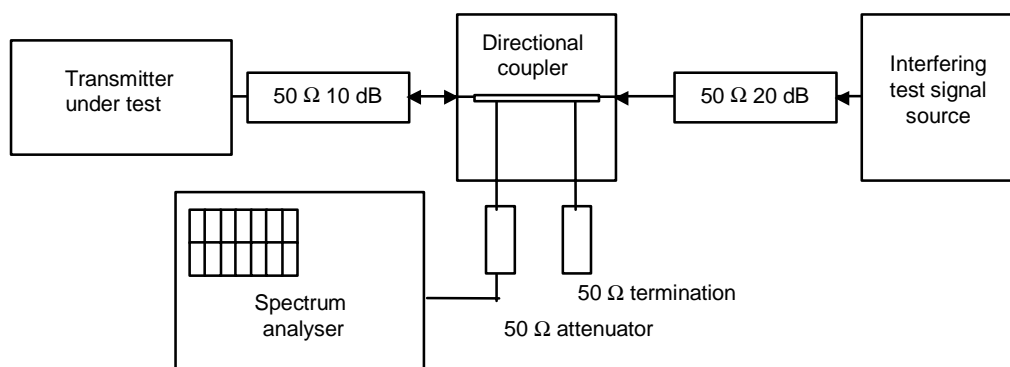

Figure 3: Measurement arrangement

The measurement arrangement shown in figure 3 shall be used.

The transmitter shall be connected to a $50\ \Omega$ 10 dB power attenuator and via a (directional) coupler to a spectrum analyser. An additional attenuator may be required between the directional coupler and the spectrum analyser to avoid overloading.

The interfering signal source may be either a transmitter providing the same power output as the transmitter under test and be of a similar type or a signal generator and a power amplifier of equivalent intermodulation attenuation as that required from the transmitter, capable of delivering the same output power as the transmitter under test. In either case the interfering signal source shall be capable of generating a CW signal at power level equivalent to PX.

The directional coupler shall have an insertion loss of less than 1 dB, a sufficient bandwidth and a directivity of more than 20 dB.

The transmitter under test and the test signal source shall be physically separated in such a way that the measurement is not influenced by direct radiation.

Prior to the measurement, the maximum power level, PX, of the transmitter under test shall be measured according to clause 7.1.2 and the value recorded.

Modulation test signal M1 or M2 (as appropriate, see clause 6.3.1) shall be applied at the transmitter. The transmitter under test shall be set in continuous transmission mode. If this is not possible, the measurement shall be carried out in a period shorter than the duration of the transmitted burst. The power level shall be PX.

The interfering test signal source shall be unmodulated and the frequency shall be within 400 kHz to 600 kHz above the frequency of the transmitter under test.

The frequency shall be chosen in such a way that the intermodulation components to be measured do not coincide with other spurious components. The power output of the interfering test signal source shall be adjusted to the PX level recorded above. The intermodulation component shall be measured by direct observation on the spectrum analyser of the largest third order intermodulation component.

This value shall be recorded.

This measurement shall be repeated with the interfering test signal source at a frequency within 400 kHz to 600 kHz below the frequency of the transmitter under test.

The intermodulation attenuation of the equipment under test is the higher of the two values recorded in above. The intermodulation attenuation ratio is the difference between the intermodulation attenuation and PX.

7.5.3 Limits

7.5.3.1 Limits for TMO repeater equipment

The level of intermodulation product shall be less than the higher of -60 dBc or -36 dBm.

7.5.3.2 Limits for non TMO repeater equipment

Two classes of transmitter intermodulation attenuation are defined, the equipment shall fulfil one of the requirements:

- in general the intermodulation attenuation ratio shall be at least 40,0 dB for any intermodulation component;
- for base station equipment to be used in special service conditions (e.g. at sites where more than one transmitter will be in service) or when the regulatory authority makes it a condition of the licence, the intermodulation attenuation ratio shall be at least 70,0 dB for any intermodulation component. In the case where the performance is achieved by additional internal or external isolating devices (such as circulators) these are expected to be available at the time the measurements are made and shall be used for the measurements.

7.6 Adjacent channel transient power measurements

7.6.1 Definition

Transients power is the power falling into adjacent spectrum due to switching the transmitter on and off.

7.6.2 Method of Measurement

Modulation test signal M1 or M2 shall be applied at the transmitter.

For TMO Repeater equipment this test shall be performed in both the uplink and downlink direction at the centre of the repeaters operating band.

The measurement procedure shall be as follows:

- a) the output of the transmitter shall be connected to the input of the spectrum analyser by a 50 Ω power attenuator to ensure that the impedance presented to the transmitter is 50 Ω and the level at the spectrum analyser input is appropriate. The spectrum analyser shall meet the requirements of annex C and its settings shall be adjusted to:
 - Zero frequency scan
 - Resolution bandwidth: 1 kHz
 - Video bandwidth: 10 kHz
 - Peak hold
- b) the transmitter shall be operated at the maximum rated transmitter power level, under normal test conditions (see clause 5.3);
- c) by tuning the spectrum analyser centre frequency to the measurement frequencies the power level is measured at the frequencies given in table 7, the measurement being carried out at positive and negative frequency offsets;

Table 7: Frequency displacements

	Adjacent Channel Measurement	1 MHz Measurement
Channel separation (kHz)	Displacement from f_c (kHz)	Displacement from f_c (MHz)
25	25	1
50	37,5	1
100	62,5	1
150	87,5	1

the duration of each measurement (at each frequency) will be such as to cover at least 10 transmissions at f_c , each transmission consisting of a Rx to Tx followed by a Tx to Rx transition;

- d) the spectrum analyser shall be used to record the envelope of the transient power as a function of time. The peak envelope transient power shall be noted for each measurement offset.

7.6.3 Limits

The transient power, in the adjacent channels shall not exceed a value of 45 dB below the PR of the transmitter, without the need to be below $2 \mu\text{W}$ (-27,0 dBm).

For measurements at 1 MHz the transient power shall not exceed 45 dB below the PR of the transmitter, without the need to be below $2 \mu\text{W}$ (-27,0 dBm).

7.7 Frequency error

7.7.0 General

For equipment that can be measured for frequency error, under this clause, the supplier may choose to omit this test if the adjacent and alternate channel power is measured under extreme test conditions in clause 7.3.

7.7.1 Definition

The frequency error of the transmitter is the difference between the measured carrier frequency in the absence of modulation (or with modulation, provided that the presence of modulation allows sufficiently accurate measurement of the carrier frequency), and the nominal frequency of the transmitter.

7.7.2 Method of measurement

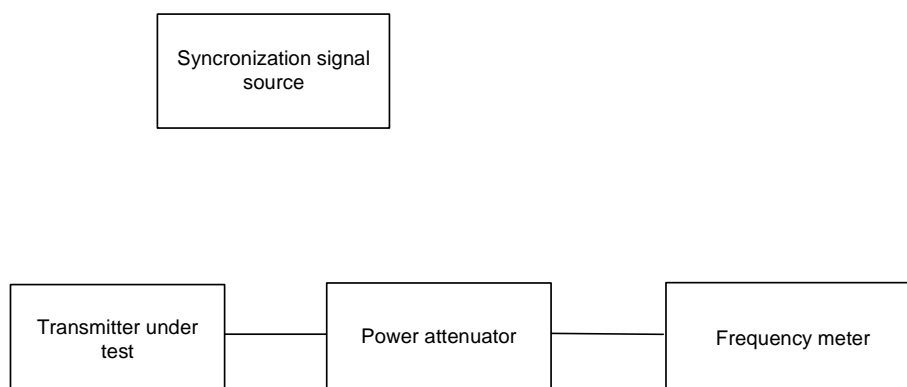

Figure 4: Measurement arrangement

The equipment shall be connected via the power attenuator to the frequency meter as shown in figure 4.

The carrier frequency shall be measured in the absence of modulation unless a particular signal exists that allows carrier frequency measurement. Such a signal shall be declared by the supplier. The measurement shall be made under normal test conditions (see clause 5.3) and extreme test conditions (see clauses 5.4.1 and 5.4.2 applied simultaneously).

For equipment that does not permit transmission without synchronizing to a base station the frequency error of the transmitter shall be measured after the equipment has synchronized to a suitable signal, as specified by the supplier. Such equipment shall prohibit start of transmission if synchronization has not been performed for greater than 4 minutes prior to transmission.

Details of any synchronization signals used and timings of these signals shall be recorded in the test report.

7.7.3 Limits

The frequency error shall not exceed the values given in table 8, under normal and extreme test conditions, or in any intermediate set of conditions. However, for practical reasons the measurement shall be performed only at nominal and extreme test conditions.

Table 8: Frequency error

Frequency error limit				
Below 47 MHz	47 MHz to 137 MHz	Above 137 MHz to 500 MHz	Above 500 MHz to 1 000 MHz	Above 1 000 MHz
±0,60 kHz	±1,35 kHz	±2,00 kHz	±2,50 kHz	±2,50 ppm
NOTE: For mobile and hand portable equipment that is tested following synchronization (see clause 7.7.2) the frequency error shall at no time exceed the above limits up to 4 minutes after the start of transmission.				

7.8 Out of band gain for TMO repeater equipment

7.8.0 Applicability

This requirement only applies to TMO repeater equipment.

7.8.1 Definition

Out of band gain refers to the net gain of the repeater outside the relevant transmit bands. The test also checks the net gain at harmonic frequencies.

7.8.2 Method of measurement

The TMO repeater shall be set to maximum gain. In case of a channelized repeater, two of the channel selective modules shall be set to the lowermost and the uppermost channels within the repeater's operating band.

A continuous sinusoidal RF signal shall be fed successively at frequency offsets Y from the edges of the relevant MS or BS transmit frequency band into the relevant input port of the repeater. The frequency offsets Y shall have the following values:

- 50 kHz;
- 75 kHz;
- 125 kHz;
- 250 kHz; and
- 500 kHz.

The test shall be repeated with an continuous sinusoidal RF signal successively set to all harmonic frequencies of the repeaters operating band up to 12,75 GHz (i.e. multiples of the centre frequency of the repeaters operating band up to 12,75 GHz).

The power level of the RF input signal shall be at least 5 dB below the power level which would produce, when applied within the operating band, the rated output power, as declared by the supplier. This is to ensure that the equipment is operating in the linear output range.

Alternatively the measurement of the net gain over the above defined frequency range can be done with a network analyser.

The average output power in each case shall be measured and the net gain shall be recorded.

The measurements shall apply to both the uplink and downlink direction of the repeater.

The measurement shall be made under normal test conditions (see clause 5.3) and extreme test conditions (see clauses 5.4.1 and 5.4.2).

7.8.3 Limits

For TMO repeaters with an operating frequency band of 1 MHz or less the limits detailed in table 9 shall not be exceeded.

Table 9: Maximum gain

Frequency offset from the - 6 dB point	Maximum gain
50 kHz	63 dB
75 kHz	50 dB
125 kHz	30 dB
250 kHz	20 dB
≥ 500 kHz	10 dB

For TMO repeaters with an operating frequency band greater than 1 MHz the limits detailed in table 10 shall not be exceeded.

Table 10: Maximum gain

Frequency offset from the - 6 dB point	Maximum gain
50 kHz	75 dB
75 kHz	70 dB
125 kHz	65 dB
250 kHz	32 dB
≥ 500 kHz	28 dB

The limits in tables 9 and 10 shall be applicable for tests under normal test conditions (see clause 5.3) and extreme test conditions (see clauses 5.4.1 and 5.4.2).

7.9 Modulation accuracy

7.9.0 Applicability

This requirement only applies to TMO repeater equipment.

7.9.1 Definition

Modulation accuracy is defined according to ETSI EN 300 392-2 [5], clause 6.4.

NOTE: TETRA modulation [5] is used in this test as a measurement of modulation accuracy.

7.9.2 Method of measurement

The modulation accuracy shall be tested as follows:

- a) the test shall be carried out at maximum nominal gain;
- b) a T2 test signal shall be applied to the repeater;

- c) a measurement system shall capture a representation of the transmit burst's vector error at sampling times t_k (symbol by symbol) where t_k is the symbol time corresponding to the k^{th} symbol; for each symbol the sampling system shall compute the vector error $Z'(k) - S(k)$ defined in ETSI EN 300 392-2 [5], clause 6.6.1.2, where $Z'(k)$ is the normalized modulation symbol transmitted by the MS and $S(k)$ is the modulation symbol which would be transmitted by an ideal MS; the measurement system shall calculate the RMS vector error for all symbols of the burst as defined in ETSI EN 300 392-2 [5], clause 6.6.1.2; the measuring system shall also calculate the peak vector error magnitude $|Z'(k)-S(k)|$ as defined in ETSI EN 300 392-2 [5], clause 6.6.1.2 for each symbol of the burst and shall calculate the mean residual carrier magnitude $\langle C_0 \rangle$ averaged over all values C_0 of the burst;
- d) the procedure described in step c) shall be repeated for 200 bursts;
- e) the procedures described in steps a) to b) shall be performed on the lowest, highest and middle radio frequency channel in the transmit band;
- f) the measurements shall be repeated for both the uplink and downlink directions of the repeater.

7.9.3 Limits

The RMS vector error in any burst shall be less than 0,1 for any symbol.

The peak vector error magnitude shall be less than 0,3 for any symbol.

8 Technical characteristics of the receiver

8.0 Applicability

The receiver requirements in clauses 8.1 to 8.7 require the possibility to demodulate the received signal to make the various measurements however a TMO repeater is, in principle, a bidirectional (uplink and downlink) amplifier, which does not have a receiver in this sense

NOTE: The TMO repeater does not demodulate.

Repeater requirements are defined for both directions of the repeater (uplink and downlink) and hence can be considered as receiver requirements as well. As a result receiver requirements from clauses 8.1 to 8.7 shall not apply to TMO Repeaters.

8.1 Receiver sensitivity (conducted)

8.1.0 General

This measurement applies only for equipment with an external antenna connector.

8.1.1 Definition

The maximum usable sensitivity (conducted) is the minimum average signal power at the receiver input, produced by a signal at the nominal frequency of the receiver, modulated with the normal test signal (see clause 6.3.2), which will, without interference, produce after demodulation a data signal with a specified bit error ratio or a specified successful message ratio. The specified bit error ratio is 10^{-2} . The specified successful message ratio is 80 %.

8.1.2 Method of measurement

8.1.2.1 Method of measurement with continuous bit streams

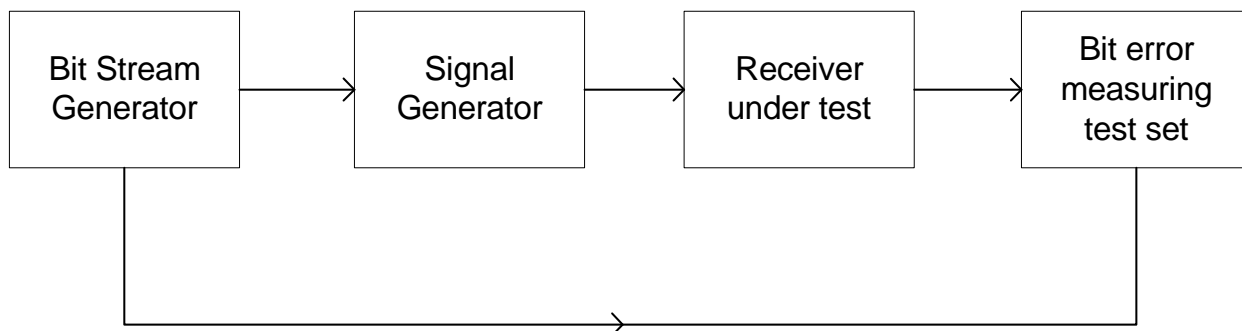

Figure 5: Measurement arrangement

The measurement arrangement is shown in figure 5. The measurement procedure shall be as follows:

- an input signal with a frequency equal to the nominal frequency of the receiver, modulated by the normal test signal M3 (see clause 6.3.2), shall be applied to the receiver input terminals;
- the bit pattern of the modulating signal shall be compared to the bit pattern obtained from the receiver after demodulation;
- the level of the input signal to the receiver is adjusted until the bit error ratio is 10^{-2} or better is obtained;
the maximum usable sensitivity is the mean level of the input signal to the receiver;
this value shall be recorded;
- the measurement shall be repeated under extreme test conditions (see clauses 5.4.1 and 5.4.2 applied simultaneously).

8.1.2.2 Method of measurement with messages or packets

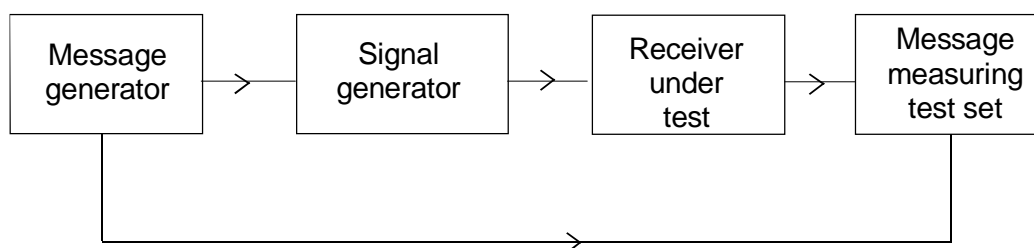

Figure 6: Measurement arrangement

The measurement arrangement is shown in figure 6. The measurement procedure shall be as follows:

- an input signal with a frequency equal to the nominal frequency of the receiver, having test modulation M4 (see clause 6.3.2), in accordance with the instructions of the supplier shall be applied to the receiver input terminals;
- the level of this signal shall be such that a successful message ratio of less than 10 % is obtained;
- the normal test signal M4 (see clause 6.3.2) shall then be transmitted repeatedly and the content of the decoded messages compared to the transmitted data;
- the level of the input signal to the receiver is adjusted until a successful message ratio of 80 % or greater is obtained;
the maximum usable sensitivity is the mean level of the input signal to the receiver;
this value shall be recorded;

- e) the measurement shall be repeated under extreme test conditions (see clauses 5.4.1 and 5.4.2).

8.1.3 Limits

The maximum usable sensitivity shall not exceed the values given in table 11 under normal test conditions, and the values in table 11 plus 3 dB under extreme test conditions.

Table 11: Sensitivity levels (mean power) for different channel bandwidths and gross (on-air) bit rates

Channel BW	Data Rate	Sensitivity
25 kHz	38,4 kbit/s or less	-111 dBm
	38,5 kbits to 76,8 kbit/s	-104 dBm
	Greater than 76,8 kbit/s	-99 dBm
50 kHz	76,8 kbit/s or less	-108 dBm
	76,9 kbits to 153,6 kbit/s	-101 dBm
	Greater than 153,6 kbit/s	-95 dBm
100 kHz	153,6 kbit/s or less	-105 dBm
	153,7 kbits to 307,2 kbit/s	-98 dBm
	Greater than 307,2 kbit/s	-93 dBm
150 kHz	230,4 kbit/s or less	-103 dBm
	230,5 kbits to 460,8 kbit/s	-97 dBm
	Greater than 460,8 kbit/s	-91 dBm

8.2 Maximum usable sensitivity (field strength)

8.2.0 General

This measurement applies only for equipment without an external antenna connector.

8.2.1 Definition

The maximum usable sensitivity (data) expressed as field strength is the average field strength, expressed in dB μ V/m, produced by a signal at the nominal frequency of the receiver, modulated with the test signal M3 or M4 (see clause 6.3.2) which will, without interference, produce after demodulation a data signal with a specified bit error ratio or a specified successful message ratio.

The specified bit error ratio is 10^{-2} . The specified successful message ratio is 80 %.

8.2.2 Method of measurement

8.2.2.0 General

For equipment that supports adaptive rates, testing is only required at two bit rates, the minimum bit rate supported by the equipment and the maximum bit rate that the supplier declares is compliant to the present document.

The supplier shall specify the polarization of the RF field for which the equipment has been designed.

Three test scenarios are possible:

- the supplier declares the direction corresponding to the maximum usable sensitivity. In this case this position is used to perform the measurement in clauses 8.2.2.1 or 8.2.2.2;
- if the supplier does not declare the position corresponding to the maximum usable sensitivity but provides an analogue output according to clause 6.11, then this output will be used to determine the direction of maximum usable sensitivity. This will be the position used for the measurement in clauses 8.2.2.1 or 8.2.2.2;

- c) if the direction corresponding to the maximum usable sensitivity cannot be determined as specified in a) or b) above, then an initial position will be used and the measurement in clauses 8.2.2.1 or 8.2.2.2 will be repeated with eight positions, 45° apart. The maximum usable sensitivity will be determined from the minimum field strength recorded.

8.2.2.1 Method of measurement with continuous bit streams

Arrangements shall be made by the supplier to couple the equipment under test to the bit error measuring device by a method which does not affect the radiated field.

A test site which fulfils the requirements for the specified frequency range of this measurement shall be used (see annex B).

The test antenna shall be orientated for the polarization specified by the supplier and the length of the test antenna shall be chosen to correspond to the frequency of the receiver.

The equipment and its antenna shall be mounted in a normal installation in its normal operating position and shall be placed at the specified height on a non-conducting support, in the position determined in clause 8.2.2. The position shall be recorded in the test report:

- a) a signal generator shall be connected to the test antenna;
 - the signal generator shall be at the nominal frequency of the receiver and shall have the test signal M3 (see clause 6.3.2);
- b) the bit pattern of the modulating signal shall be compared to the bit pattern provided by the receiver after demodulation, in order to obtain the bit error ratio;
- c) the level of the signal generator shall be adjusted until a bit error ratio of approximately 10^{-1} is obtained;
- d) the test antenna shall be raised or lowered through the specified height range to find the lowest bit error ratio;
 - the test antenna may not need to be raised or lowered if a test site according to clause B.1.1 is used, or if the ground floor reflection can effectively be eliminated;
- e) the level of the signal generator shall be re-adjusted until a bit error ratio of 10^{-2} is obtained; the mean input signal level to the test antenna shall be noted and maintained;
- f) the receiver shall then be replaced by a substitution antenna as defined in clause B.1.5;
 - the substitution antenna shall be orientated for the polarization of the test antenna and the length of the substitution antenna shall be adjusted to correspond to the frequency of the receiver;
- g) the substitution antenna shall be connected to a calibrated measuring receiver;
 - the test antenna shall be raised and lowered through the specified range of height to ensure that the maximum signal is received;
 - the test antenna need not be raised or lowered if the measurement is carried out on a test site according to clause B.1.1;
- h) the measured mean signal level shall be recorded as field strength in dB μ V/m, this is the maximum usable sensitivity, corresponding to the direction used.

8.2.2.2 Method of measurement with messages

Arrangements shall be made by the supplier to couple the equipment under test to the message measuring device by a method which does not affect the radiated field.

A test site which fulfils the requirements for the specified frequency range of this measurement shall be used (see annex B).

The test antenna shall be orientated for the polarization specified by the supplier and the length of the test antenna shall be chosen to correspond to the frequency of the receiver.

The equipment and its antenna shall be mounted in a normal installation in its normal operating position and shall be placed at the specified height on a non-conducting support, in the position determined in clause 8.2.2. The position shall be recorded in the test report.

- a) a signal generator shall be connected to the test antenna;
the signal generator shall be at the nominal frequency of the receiver and shall have the test signal M4 (see clause 6.3.2);
- b) the level of the signal generator shall be adjusted until a successful message ratio of less than 10 % is obtained;
- c) the test antenna shall be raised or lowered through the specified height range to find the maximum successful message ratio;
the test antenna may not need to be raised or lowered if a test site according to clause B.1.1 is used, or if the ground floor reflection can effectively be eliminated;
- d) the level of the test signal shall be re-adjusted to produce the successful message ratio specified in step b);
- e) the test signal M4 shall be transmitted repeatedly and the content of the decoded messages compared to the transmitted data;
- f) the mean level of the input signal to the receiver is adjusted until a successful message error ratio of 80 % or greater is obtained;
- g) the receiver shall then be replaced by a substitution antenna as defined in clause B.1.5;
the substitution antenna shall be orientated for the polarization of the test antenna and the length of the substitution antenna shall be adjusted to correspond to the frequency of the receiver;
- h) the substitution antenna shall be connected to a calibrated measuring receiver;
the test antenna shall be raised and lowered through the specified range of height to ensure that the maximum signal is received;
the test antenna need not be raised or lowered if the measurement is carried out on a test site according to clause B.1.1;
- i) the measured mean signal level shall be recorded as field strength in dB μ V/m; this is the maximum usable sensitivity, corresponding to the direction used.

8.2.3 Limits

This requirement applies only to equipment not having an external antenna connector.

The maximum usable sensitivity shall not exceed the field strength value shown in tables 12a to 12d.

Table 12a: Maximum usable sensitivity (25 kHz Channels) for different gross (on-air) bit rates

Frequency band (MHz)	Data Rate	Field strength in dB relative to 1 μ V/m (Normal test conditions)
30 to 100	38,4 kbit/s or less	10 dB
	38,5 kbits to 76,8 kbit/s	17 dB
	Greater than 76,8 kbit/s	22 dB
100 to 230	38,4 kbit/s or less	16 dB
	38,5 kbits to 76,8 kbit/s	23 dB
	Greater than 76,8 kbit/s	28 dB
230 to 470	38,4 kbit/s or less	22 dB
	38,5 kbits to 76,8 kbit/s	29 dB
	Greater than 76,8 kbit/s	34 dB
470 to 3 000	38,4 kbit/s or less	28 dB
	38,5 kbits to 76,8 kbit/s	35 dB
	Greater than 76,8 kbit/s	40 dB

Table 12b: Maximum usable sensitivity (50 kHz Channels) for different gross (on-air) bit rates

Frequency band (MHz)	Data Rate	Field strength in dB relative to 1 μ V/m (Normal test conditions)
30 to 100	38,4 kbit/s or less	13 dB
	38,5 kbits to 76,8 kbit/s	20 dB
	Greater than 76,8 kbit/s	26 dB
100 to 230	38,4 kbit/s or less	19 dB
	38,5 kbits to 76,8 kbit/s	26 dB
	Greater than 76,8 kbit/s	32 dB
230 to 470	38,4 kbit/s or less	25 dB
	38,5 kbits to 76,8 kbit/s	32 dB
	Greater than 76,8 kbit/s	38 dB
470 to 3 000	38,4 kbit/s or less	31 dB
	38,5 kbits to 76,8 kbit/s	38 dB
	Greater than 76,8 kbit/s	44 dB

Table 12c: Maximum usable sensitivity (100 kHz Channels) for different gross (on-air) bit rates

Frequency band (MHz)	Data Rate	Field strength in dB relative to 1 μ V/m (Normal test conditions)
30 to 100	38,4 kbit/s or less	16 dB
	38,5 kbits to 76,8 kbit/s	23 dB
	Greater than 76,8 kbit/s	28 dB
100 to 230	38,4 kbit/s or less	22 dB
	38,5 kbits to 76,8 kbit/s	29 dB
	Greater than 76,8 kbit/s	34 dB
230 to 470	38,4 kbit/s or less	28 dB
	38,5 kbits to 76,8 kbit/s	35 dB
	Greater than 76,8 kbit/s	40 dB
470 to 3 000	38,4 kbit/s or less	34 dB
	38,5 kbits to 76,8 kbit/s	41 dB
	Greater than 76,8 kbit/s	46 dB

Table 12d: Maximum usable sensitivity (150 kHz Channels) for different gross (on-air) bit rates

Frequency band (MHz)	Data Rate	Field strength in dB relative to 1 μ V/m (Normal test conditions)
30 to 100	38,4 kbit/s or less	18 dB
	38,5 kbits to 76,8 kbit/s	24 dB
	Greater than 76,8 kbit/s	30 dB
100 to 230	38,4 kbit/s or less	24 dB
	38,5 kbits to 76,8 kbit/s	30 dB
	Greater than 76,8 kbit/s	36 dB
230 to 470	38,4 kbit/s or less	30 dB
	38,5 kbits to 76,8 kbit/s	36 dB
	Greater than 76,8 kbit/s	42 dB
470 to 3 000	38,4 kbit/s or less	36 dB
	38,5 kbits to 76,8 kbit/s	42 dB
	Greater than 76,8 kbit/s	48 dB

8.3 Blocking or desensitization

8.3.1 Definition

Blocking is a measure of the capability of the receiver to receive a wanted modulated signal without exceeding a given degradation due to the presence of an unwanted input signal at any frequencies other than those of the spurious responses or the adjacent channels.

8.3.2 Method of measurement

8.3.2.1 Method of measurement with continuous transmissions

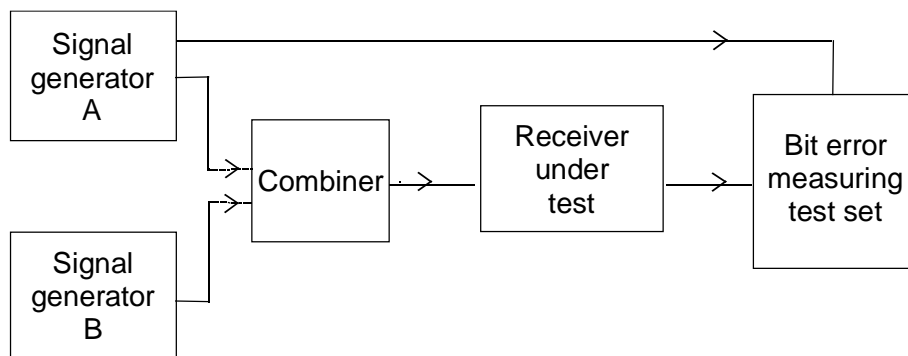

Figure 7: Measurement arrangement

The measurement arrangement is shown in figure 7. The measurement procedure shall be as follows:

- a) two signal generators, A and B, shall be connected to the receiver via a combining network:
 - the wanted signal, provided by signal generator A, shall be at the nominal frequency of the receiver and shall be modulated by the normal test signal M3 (see clause 6.3.2);
 - the unwanted signal, provided by signal generator B, shall be unmodulated and shall be at a frequency from 1 MHz to 10 MHz away from the nominal frequency of the receiver;

for practical reasons the measurements shall be carried out at frequencies of the unwanted signal at approximately ± 1 MHz, ± 2 MHz, ± 5 MHz and ± 10 MHz, avoiding those frequencies at which spurious responses occur;

- b) initially, signal generator B (unwanted signal) shall be switched off (maintaining the output impedance);

the level of the wanted signal from generator A shall be adjusted to the level which is 3 dB above the level of the limit of the maximum usable sensitivity (table 11), at the receiver input terminals;
- c) signal generator B shall then be switched on, and the level of the unwanted signal adjusted until a bit error ratio of 10^{-1} or worse is obtained;
- d) the normal test signal M3 shall be transmitted whilst observing the bit error ratio;
- e) the level of the unwanted signal shall be reduced in steps of 1 dB until a bit error ratio of 10^{-2} or better is obtained. The level of the unwanted signal shall then be recorded;
- f) the measurement shall be repeated for all the frequencies defined in step a);
- g) the blocking level of the equipment under test shall be expressed as the lowest of the values recorded in step e).

8.3.2.2 Method of measurement with messages

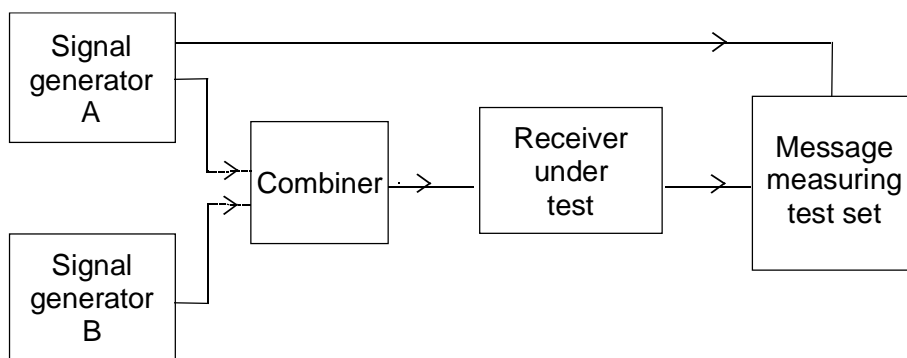

Figure 8: Measurement arrangement

The measurement arrangement is shown in figure 8. The measurement procedure shall be as follows:

- a) two signal generators, A and B, shall be connected to the receiver via a combining network:
 - the wanted signal, provided by signal generator A, shall be at the nominal frequency of the receiver and shall be modulated by the normal test signal M4 (see clause 6.3.2);
 - the unwanted signal, provided by signal generator B, shall be unmodulated and shall be at a frequency from 1 MHz to 10 MHz away from the nominal frequency of the receiver;

for practical reasons the measurements shall be carried out at frequencies of the unwanted signal at approximately ± 1 MHz, ± 2 MHz, ± 5 MHz and ± 10 MHz, avoiding those frequencies at which spurious responses occur;
- b) initially, signal generator B (unwanted signal) shall be switched off (maintaining the output impedance);

the level of the wanted signal from generator A shall be adjusted to the level which is 3 dB above the level of the limit of the maximum usable sensitivity (table 11) at the receiver input terminals;
- c) signal generator B shall then be switched on, and the level of the unwanted signal adjusted until a successful message ratio of less than 10 % is obtained;
- d) the normal test signal M4 (see clause 6.3.2) shall then be transmitted repeatedly and the content of the decoded messages compared to the transmitted data;
- e) the level of the unwanted signal shall be adjusted until a successful message ratio of 80 % or greater is obtained;

the level of the unwanted signal shall then be recorded;
- f) the measurement shall be repeated for all the frequencies defined in step a);
- g) the blocking level of the equipment under test shall be expressed as the lowest of the values recorded in step e).

8.3.3 Limits

The blocking level for any frequency within the specified ranges shall not be less than -27 dBm.

8.4 Adjacent channel selectivity

8.4.1 Definition

The adjacent channel selectivity is the measure of the capability of the receiver to receive a wanted modulated signal at the nominal frequency without exceeding a given degradation due to the presence of an unwanted signal which differs in frequency from the wanted signal in the 25 kHz channels adjacent to the channel for which the equipment is intended.

The CSP of the equipment shall be declared by the supplier.

8.4.2 Method of measurement

8.4.2.1 Method of measurement (with continuous bit stream)

For equipment that supports adaptive rates, testing is only required at the maximum bit rate that the supplier declares is compliant to the present document.

The measurement procedure shall be as follows:

- a) two signal generators, A and B, shall be connected to the receiver via a combining network;
 - the wanted signal, provided by signal generator A, shall be at the nominal frequency of the receiver and shall be modulated by the test signal M3 (see clause 6.3.2);
 - the unwanted signal, provided by signal generator B, shall be modulated test signal M5 (see clause 6.3.2) and shall be at the frequency of the channel immediately above that of the wanted signal (see table 13);

Table 13: Summary of measurement offset

	25 kHz Channels	50 kHz Channels	100 kHz Channels	150 kHz Channels
Nominal Channel Bandwidth (for measurement of PR)	25 kHz	50 kHz	100 kHz	150 kHz
Centre of Adjacent Channel (relative to centre of the nominal channel)	±25 kHz	±37,5 kHz	±62,5 kHz	±87,5 kHz

- b) initially, signal generator B (unwanted signal) shall be switched off (maintaining the output impedance);
 - the level of the wanted signal from generator A shall be adjusted to the level which is 3 dB above the relevant limit in table 11, at the receiver input terminals;
- c) signal generator B shall then be switched on, and the level of the unwanted signal adjusted until a bit error ratio of 10^{-1} or worse is obtained;
- d) the test signal M3 shall be transmitted whilst observing the bit error ratio;
- e) the level of the unwanted signal shall be reduced in steps of 1 dB until a bit error ratio of 10^{-2} or better is obtained. The mean level of the unwanted signal shall then be recorded;
- f) the measurement shall be repeated with the unwanted signal at the frequency of the channel below that of the wanted signal;
- g) the adjacent channel selectivity of the equipment under test shall be expressed as the lower of the two values measured in step e) above;
- h) the measurement shall be repeated under extreme test conditions (see clauses 5.4.1 and 5.4.2 applied simultaneously), with the amplitude of the wanted test signal adjusted to a level 9 dB above the relevant limit, for normal conditions, in table 11.

8.4.2.2 Method of measurement with messages

For equipment that supports adaptive rates, testing is only required at the maximum bit rate that the supplier declares is compliant to the present document.

The measurement procedure shall be as follows:

- a) two signal generators, A and B, shall be connected to the receiver via a combining network;
 - the wanted signal, provided by signal generator A, shall be at the nominal frequency of the receiver and shall have test signal M4 (see clause 6.3.2);
 - the unwanted signal, provided by signal generator B, shall be modulated test signal M5 (see clause 6.3.2) and shall be at the frequency of the channel immediately above that of the wanted signal (see table 11);
- b) initially, signal generator B (unwanted signal) shall be switched off (maintaining the output impedance);
the level of the wanted signal from generator A shall be adjusted to the level which is 3 dB above the relevant limit in table 11, at the receiver input terminals;
- c) signal generator B shall then be switched on, and the level of the unwanted signal adjusted until a successful message ratio of less than 10 % is obtained;
- d) the normal test signal M4 (see clause 6.3.2) shall then be transmitted repeatedly and the content of the decoded messages compared to the transmitted data;
- e) the level of the unwanted signal shall be adjusted until a successful message ratio of 80 % or greater is obtained;
the mean level of the unwanted signal shall then be recorded;
- f) the measurement shall be repeated with the unwanted signal at the frequency of the channel below that of the wanted signal;
- g) the adjacent channel selectivity of the equipment under test shall be expressed as the lower of the two values measured in step e) above;
- h) the measurement shall be repeated under extreme test conditions (see clauses 5.4.1 and 5.4.2 applied simultaneously), with the amplitude of the wanted test signal adjusted to a level 9 dB above the relevant limit, for normal conditions, in table 11.

8.4.3 Limits

The minimum adjacent channel levels for are shown in table 14.

Table 14: Minimum adjacent channel unwanted signal mean power levels

Channel bandwidth	Interferer level for MS	Interferer level for BS
25 kHz	-63 dBm	-63 dBm
50 kHz	-66 dBm	-66 dBm
100 kHz	-67 dBm	-67 dBm
150 kHz	-67 dBm	-67 dBm

8.5 Spurious radiations

8.5.1 Definition

Spurious radiations from the receiver are components at any frequency, radiated by the equipment and antenna. For transmit only equipment that does not have a receiver this requirement shall apply with the transmitter in an inactive or standby condition.

For equipment with an external 50 Ω antenna connector, the levels of spurious radiations are considered to be:

- a) their power level in a specified load (conducted spurious emission); and

- b) their effective radiated power when radiated by the cabinet and structure of the equipment (cabinet radiation);
or for equipment without an external antenna connector;
- c) their effective radiated power when radiated by the cabinet and the integral antenna.

NOTE: There are only two options allowed - either both a) and b) or only c).

8.5.2 Methods of measurement

8.5.2.1 Method of measuring the power level in a specified load (clause 8.5.1 a))

This method applies only to equipment with an external 50 Ω antenna connector.

For equipment that supports adaptive rates, testing is only required at the maximum bit rate that the supplier declares is compliant to the present document.

Spurious radiations shall be measured as the power level of any discrete signal at the input terminals of the receiver. The receiver input terminals are connected to a spectrum analyser or selective voltmeter having an input impedance of 50 Ω and the receiver switched on.

If the detecting device is not calibrated in terms of power input, the level of any detected components shall be determined by a substitution method using a signal generator.

The measurements shall extend over the frequency range 9 kHz to 4 GHz for equipment operating on frequencies not exceeding 470 MHz or over the frequency range 9 kHz to 12,75 GHz for equipment operating on frequencies above 470 MHz.

At each frequency at which a spurious component is detected, the power level shall be recorded as the spurious level delivered into the specified load.

8.5.2.2 Method of measuring the effective radiated power (clause 8.5.1 b))

This method applies only to equipment having an external antenna connector.

For equipment that supports adaptive rates, testing is only required at the maximum bit rate that the supplier declares is compliant to the present document.

The measurement procedure shall be as follows:

- a) a test site which fulfils the requirements for the specified frequency range of this measurement shall be used (see annex B);
the equipment shall be placed at the specified height on a non-conducting support and in the position closest to normal use as declared by the supplier;
- b) the receiver antenna connector shall be connected to an artificial antenna (see clause 6.2):
 - the test antenna shall be orientated for vertical polarization and the length of the test antenna shall be chosen to correspond to the frequency of the measuring receiver;
 - the output of the test antenna shall be connected to a measuring receiver;
- c) radiation of any spurious components shall be detected by the test antenna and receiver, over the frequency range 30 MHz to 4 GHz. For equipment operating on frequencies above 470 MHz the measurements shall also be performed over the frequency range 4 GHz to 12,75 GHz if emissions are detected within 10 dB of the specified limit between 1,5 GHz and 4 GHz;
- d) at each frequency at which a component is detected the test antenna shall be raised and lowered through the specified range of height until a maximum signal level is detected by the measuring receiver;
when a test site according to clause B.1.1 is used, there is no need to vary the height of the antenna;
- e) the receiver shall then be rotated through 360° in the horizontal plane until the maximum signal level detected by the measuring receiver;

the maximum signal level detected by the measuring receiver shall be noted;

- f) the receiver shall be replaced by a substitution antenna as defined in clause B.1.5;
the substitution antenna shall be orientated for vertical polarization and the length of the substitution antenna shall be adjusted to correspond to the frequency of the spurious component detected;
- g) the substitution antenna shall be connected to a calibrated signal generator;
the frequency of the calibrated signal generator shall be set to the frequency of the spurious component detected;
- h) the input attenuator setting of the measuring receiver shall be adjusted in order to increase the sensitivity of the measuring receiver if necessary;
- i) the test antenna shall be raised and lowered through the specified range of height to ensure that the maximum signal is received;
the input signal to the substitution antenna shall be adjusted to the level that produces a level detected by the measuring receiver, that is equal to the level noted while the spurious component was measured, corrected for the change of input attenuator setting of the measuring receiver;
the input level of the substitution antenna shall be recorded as a power level, corrected for the change of input attenuator setting of the measuring receiver;
- j) the measurement shall be repeated with the test antenna and the substitution antenna orientated for horizontal polarization;
- k) the measure of the effective radiated power of the spurious components is the larger of the two power levels recorded for each spurious component at the input to the substitution antenna, corrected for the gain of the antenna if necessary.

8.5.2.3 Method of measuring the effective radiated power (clause 8.5.1 c))

This method applies only to equipment without an external antenna connector.

For equipment that supports adaptive rates, testing is only required at the maximum bit rate that the supplier declares is compliant to the present document.

The method of measurement shall be performed according to clause 8.5.2.2, except that the equipment and its antenna shall be mounted in a normal installation in its normal operating position.

8.5.3 Limits

The mean power of any spurious radiations shall not exceed the values given in tables 15a and 15b using the appropriate reference bandwidths from table 16.

Table 15a: Conducted components

Frequency range	9 kHz to 1 GHz	Above 1 GHz to 4 GHz, or above 1 GHz to 12,75 GHz, (see clause 8.5.2)
Limit	2,0 nW (-57,0 dBm)	20,0 nW (-47,0 dBm)

Table 15b: Radiated components

Frequency range	30 MHz to 1 GHz	Above 1 GHz to 4 GHz or above 1 GHz to 12,75 GHz (see clause 8.5.2.2)
Limit	2,0 nW (-57,0 dBm)	20,0 nW (-47,0 dBm)

Table 16: Reference bandwidths to be used for the measurement of spurious radiations

Frequency range	Reference bandwidth
9 kHz to 150 kHz	1 kHz
150 kHz to 30 MHz	10 kHz
30 MHz to 1 GHz	100 kHz
1 GHz to 12,75 GHz	1 MHz

8.6 Co-channel rejection

8.6.1 Definition

The co-channel rejection is a measure of the capability of the receiver to receive a wanted modulated signal without exceeding a given degradation due the presence of an unwanted modulated signal, both signals being at the nominal frequency of the receiver.

8.6.2 Method of measurement

8.6.2.1 Method of measurement with continuous bit streams

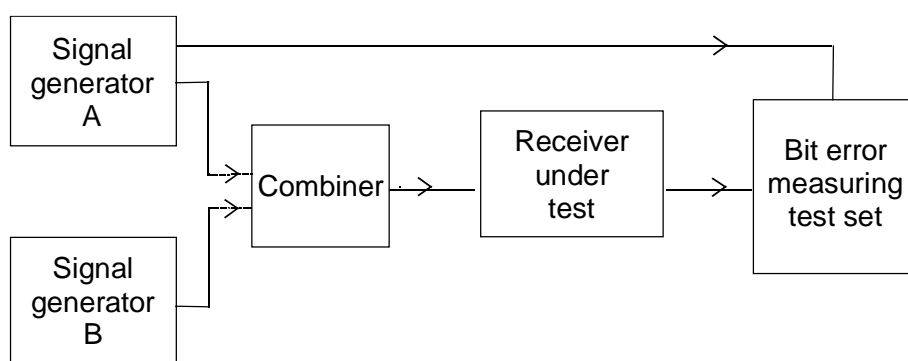
**Figure 9: Measurement arrangement**

The measurement procedure shall be as follows:

- a) two signal generators, A and B, shall be connected to the receiver via a combining network;
 - the wanted signal, provided by signal generator A, shall be at the nominal frequency of the receiver and shall be modulated by the test signal M3 (see clause 6.3.2);
 - the unwanted signal, provided by signal generator B, shall be modulated with signal M6-25, M6-50, M6-100 or M6-150 depending on the channel bandwidth (see clause 6.3.2);
 - both input signals shall be at the nominal frequency of the receiver under test;
- b) initially, signal generator B (unwanted signal) shall be switched off (maintaining the output impedance);

the level of the wanted signal from generator A shall be adjusted to a level which is 3 dB above the level of the limit of the maximum usable sensitivity as given in table 11;
- c) signal generator B shall then be switched on, and the level of the unwanted signal adjusted until a bit error ratio of 10^{-1} or worse is obtained;
- d) the test signal M2 shall be transmitted whilst observing the bit error ratio;
- e) the level of the unwanted signal shall be reduced in steps of 1 dB until a bit error ratio of 10^{-2} or better is obtained. The mean level of the unwanted signal shall then be recorded;

the co-channel rejection ratio shall be expressed as the ratio, in dB, of the mean level of the unwanted signal to the mean level of the wanted signal, at the receiver input.

NOTE: The value of the co-channel rejection ratio, expressed in dB, is generally negative (therefore, for example, -12 dB is lower than -8 dB).

8.6.2.2 Method of measurement with messages (or packets)

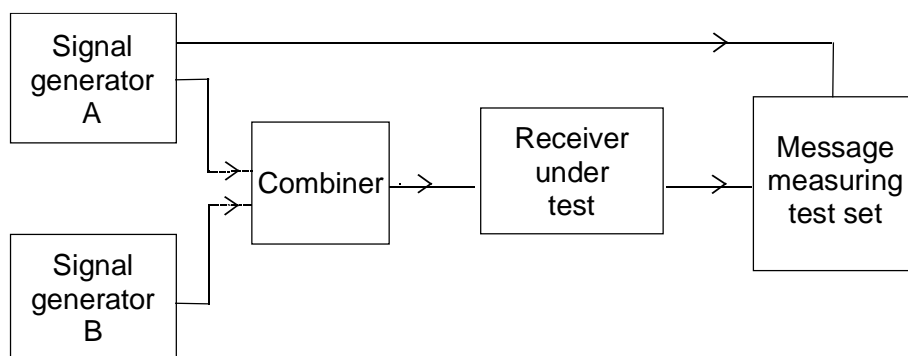

Figure 10: Measurement arrangement

The measurement procedure shall be as follows:

- a) two signal generators, A and B, shall be connected to the receiver via a combining network;
 - the wanted signal, provided by signal generator A, shall be at the nominal frequency of the receiver and shall have test modulation M4 (see clause 6.3.2);
 - the unwanted signal, provided by signal generator B, shall be modulated with signal M6-25, M6-50, M6-100 or M6-150 depending on the channel bandwidth (see clause 6.3.2);
 - both input signals shall be at the nominal frequency of the receiver;
- b) initially, signal generator B (unwanted signal) shall be switched off (maintaining the output impedance);

the level of the wanted signal from generator A shall be adjusted to a level which is 3 dB above the level of the limit of the maximum usable sensitivity at the receiver input terminals as defined in table 11;
- c) signal generator B shall then be switched on, and the level of the unwanted signal adjusted until a successful message ratio of less than 10 % is obtained;
- d) the test signal M4 (see clause 6.3.2) shall then be transmitted repeatedly and the content of the decoded messages compared to the transmitted data;
- e) the level of the unwanted signal shall be adjusted until a successful message ratio of 80 % or greater is achieved, this mean level will be recorded;
- f) the co-channel rejection ratio shall be expressed as the ratio, in dB, of the level noted in step e) to the level of the wanted signal, at the receiver input.

NOTE: The value of the co-channel rejection ratio, expressed in dB, is generally negative (therefore, for example, -12 dB is lower than -8 dB).

8.6.3 Limits

The value of the co-channel rejection ratio, expressed in dB, shall be as shown in table 17.

Table 17: Co-channel performance for different channel bandwidths and gross (on-air) bit rates

Channel BW	Data Rate	Co-channel
25 kHz	38,4 kbit/s or less	-12 dB
	38,5 kbits to 76,8 kbit/s	-19 dB
	Greater than 76,8 kbit/s	-24 dB
50 kHz	76,8 kbit/s or less	-12 dB
	76,9 kbits to 153,6 kbit/s	-19 dB
	Greater than 153,6 kbit/s	-24 dB
100 kHz	153,6 kbit/s or less	-12 dB
	153,7 kbits to 307,2 kbit/s	-19 dB
	Greater than 307,2 kbit/s	-24 dB
150 kHz	230,4 kbit/s or less	-12 dB
	230,5 kbits to 460,8 kbit/s	-19 dB
	Greater than 460,8 kbit/s	-24 dB

8.7 Intermodulation response rejection

8.7.1 Definition

The intermodulation response rejection is a measure of the capability of the receiver to receive a wanted modulated signal, without exceeding a given degradation due to the presence of two or more unwanted signals with a specific frequency relationship to the wanted signal frequency.

8.7.2 Method of measurement

8.7.2.1 Method of measurement (with continuous bit stream)

For equipment that supports adaptive rates, testing is only required at the maximum bit rate that the supplier declares is compliant to the present document.

The measurement procedure shall be as follows:

- a) three signal generators, A, B and C, shall be connected to the receiver via a combining network;
 - the wanted signal, provided by signal generator A, shall be at the nominal frequency (f_c) of the receiver and shall be modulated by the test signal M3 (see clause 6.3.2);
 - the first unwanted signal, provided by signal generator B shall be unmodulated and adjusted to a frequency above the nominal frequency of the receiver (f_1);
 - the second unwanted signal, provided by signal generator C, shall be modulated with test signal M5 (see clause 6.3.2) and adjusted above the nominal frequency of the receiver (f_2);
 - the frequencies f_c , f_1 and f_2 shall have the following relationship $f_c = 2 f_1 - f_2$ and $|f_2 - f_1| = f_x$. Where f_x is defined in table 18;

Table 18: f_x definition

Channel bandwidth	f_x
25 kHz	200 kHz
50 kHz	400 kHz
100 kHz	800 kHz
150 kHz	1 200 kHz

- b) initially, signal generators B and C (unwanted signals) shall be switched off (maintaining the output impedance);
- the level of the wanted signal from generator A shall be adjusted to the level which is 3 dB above the relevant limit in table 11, at the receiver input terminals;
- c) signal generators B and C shall then be switched on, and the mean levels of the unwanted signals shall be maintained equal and shall be adjusted until a bit error ratio of 10^{-1} or worse is obtained;
- d) the test signal M3 shall be transmitted whilst observing the bit error ratio;
- e) the mean levels of the unwanted signals shall be maintained equal and shall be reduced in steps of 1 dB until a bit error ratio of 10^{-2} or better is obtained. The mean level of the unwanted signals shall then be noted (i.e. the mean level of each signals is what is to be noted);
- f) for each configuration of the unwanted signals, the intermodulation response rejection shall be recorded as the lowest value noted in step e);
- g) the measurement shall be repeated with the unwanted signal generators B and C at the frequencies below that of the wanted signal while still meeting the relationship $f_c = 2f_1 - f_2$ and $|f_2 - f_1| = f_x$.

8.7.2.2 Method of measurement with messages

For equipment that supports adaptive rates, testing is only required at the maximum bit rate that the supplier declares is compliant to the present document.

The measurement procedure shall be as follows:

- a) three signal generators, A, B and C, shall be connected to the receiver via a combining network;
- the wanted signal, provided by signal generator A, shall be at the nominal frequency (f_c) of the receiver and shall be modulated by the test signal M4 (see clause 6.3.2);
 - the first unwanted signal, provided by signal generator B shall be unmodulated and adjusted to a frequency above the nominal frequency of the receiver (f_1);
 - the second unwanted signal, provided by signal generator C, shall be modulated with test signal M5 (see clause 6.3.2) and adjusted above the nominal frequency of the receiver (f_2);
 - the frequencies f_c , f_1 and f_2 shall have the following relationship $f_c = 2f_1 - f_2$ and $|f_2 - f_1| = f_x$. Where f_x is defined in table 16;
- b) initially, signal generators B and C (unwanted signals) shall be switched off (maintaining the output impedance);
- the level of the wanted signal from generator A shall be adjusted to the level which is 3 dB above the relevant limit or supplier's declaration in table 11, at the receiver input terminals;
- c) signal generators B and C shall then be switched on; the mean levels of the two unwanted signals shall be maintained equal and shall be adjusted until a successful message ratio of less than 10 % is obtained;
- d) the normal test signal M4 (see clause 6.3.2) shall then be transmitted repeatedly and the content of the decoded messages compared to the transmitted data;
- e) the mean levels of the two unwanted signals shall be maintained equal and shall be adjusted until a successful message ratio of 80 % or greater is obtained;

the mean level of the unwanted signals shall then be noted (i.e. the mean level of each signals is what is to be noted);

- f) for each configuration of the unwanted signals, the intermodulation response rejection shall be recorded as the lowest value noted in step e);
- g) the measurement shall be repeated with the unwanted signal generators B and C at the frequencies below that of the wanted signal while still meeting the relationship $f_c = 2f_1 - f_2$ and $|f_2 - f_1| = f_x$.

8.7.3 Limit

The intermodulation response rejection level of the equipment shall not be less than -47 dBm.

9 Measurement uncertainty

The interpretation of the results recorded in the test report for the measurements described in the present document shall be as follows:

- the measured value related to the corresponding limit shall be used to decide whether an equipment meets the requirements of the present document;
- the value of the measurement uncertainty for the measurement of each parameter shall be separately included in the test report;
- the value of the measurement uncertainty shall be, for each measurement, equal to or lower than the figures in table 19.

Table 19: Absolute measurement uncertainties: maximum values

Parameter	Uncertainty
Radio Frequency	$\pm 1 \times 10^{-7}$
RF Power (up to 160 W)	$\pm 0,75$ dB
Radiated RF power	± 6 dB
Adjacent channel power	± 5 dB
Conducted spurious emission of transmitter valid up to 12,75 GHz	± 4 dB
Conducted spurious emission of receiver, valid up to 12,75 GHz	± 7 dB
Two-signal measurement, valid up to 4 GHz	± 4 dB
Three-signal measurement	± 3 dB
Radiated emission of the transmitter, valid up to 4 GHz	± 6 dB
Radiated emission of receiver, valid up to 4 GHz	± 6 dB
Transmitter attack time	± 20 %
Transmitter release time	± 20 %
Transmitter transient frequency (frequency difference)	± 250 Hz
Transmitter intermodulation	± 3 dB
Modulation accuracy:	
• RMS vector error	$\pm 1,0$ %
• Peak vector error	$\pm 3,0$ %
Receiver desensitization	$\pm 0,5$ dB
Temperature	± 2 K
Humidity	± 10 %
NOTE: Valid up to 1 GHz for the RF parameters unless otherwise stated.	

For the test methods, according to the present document, the measurement uncertainty figures shall be calculated in accordance with ETSI TR 100 028 [2] and shall correspond to an expansion factor (coverage factor) $k = 1,96$ or $k = 2$ (which provide confidence levels of respectively 95 % and 95,45 % in the case where the distributions characterizing the actual measurement uncertainties are normal (Gaussian)).

Table 17 is based on such expansion factors.

The particular expansion factor used for the evaluation of the measurement uncertainty shall be stated.

ETSI TR 102 273 [3] provides further information concerning the usage of test sites.

Annex A (normative): Relationship between the present document and the essential requirements of Directive 2014/53/EU

The present document has been prepared under the Commission's standardisation request C(2015) 5376 final [i.9] to provide one voluntary means of conforming to the essential requirements of Directive 2014/53/EU on the harmonisation of the laws of the Member States relating to the making available on the market of radio equipment and repealing Directive 1999/5/EC [i.3].

Once the present document is cited in the Official Journal of the European Union under that Directive, compliance with the normative clauses of the present document given in table A.1 confers, within the limits of the scope of the present document, a presumption of conformity with the corresponding essential requirements of that Directive, and associated EFTA regulations.

Table A.1: Relationship between the present document and the essential requirements of Directive 2014/53/EU

Harmonised Standard ETSI EN 302 561				
The following requirements are relevant to the presumption of conformity under the article 3.2 of Directive 2014/53/EU [i.3]				
Requirement			Requirement Conditionality	
No	Description	Reference: Clause No	U/C	Condition
1	Transmitter frequency error	7.7	C	Does not apply if transmitter adjacent and alternate channels power is measured under extreme test conditions.
2	Transmitter output power (conducted)	7.1	C	Applies to all equipment having an antenna port.
3	Transmitter effective radiated power	7.2	C	Applies to all equipment having an integral antenna.
4	Transmitter adjacent and alternate channels power	7.3	U	
5	Transmitter unwanted emissions in the spurious domain	7.4	U	
6	Transmitter intermodulation attenuation	7.5	C	Applies only to base station and TMO Repeater equipment.
7	Transmitter transient power	7.6	U	
8	Out of band gain	7.8	C	Applies only to TMO Repeater equipment.
9	Modulation Accuracy	7.9	C	Applies only to TMO Repeater equipment.
10	Receiver spurious radiations	8.5	C	Does not apply to TMO Repeater.
11	Receiver sensitivity (conducted)	8.1	C	Applies to only to equipment having an antenna port. Does not apply to TMO Repeater.
12	Receiver maximum useable sensitivity (radiated)	8.2	C	Applies to only to equipment not having an antenna port. Does not apply to TMO Repeater.
13	Receiver co-channel rejection	8.6	C	Does not apply to TMO Repeater.
14	Receiver adjacent channel selectivity	8.4	C	Does not apply to TMO Repeater.
15	Receiver inter-modulation response	8.7	C	Does not apply to TMO Repeater.
16	Receiver blocking or desensitization	8.3	C	Does not apply to TMO Repeater.

Key to columns:

Requirement:

- No** A unique identifier for one row of the table which may be used to identify a requirement.
- Description** A textual reference to the requirement.

Clause Number Identification of clause(s) defining the requirement in the present document unless another document is referenced explicitly.

Requirement Conditionality:

U/C Indicates whether the requirement shall be unconditionally applicable (U) or is conditional upon the suppliers claimed functionality of the equipment (C).

Condition Explains the conditions when the requirement shall or shall not be applicable for a requirement which is classified "conditional".

Presumption of conformity stays valid only as long as a reference to the present document is maintained in the list published in the Official Journal of the European Union. Users of the present document should consult frequently the latest list published in the Official Journal of the European Union.

Other Union legislation may be applicable to the product(s) falling within the scope of the present document.

Annex B (normative): Radiated measurement

B.1 Test sites and general arrangements for measurements involving the use of radiated fields

B.1.0 General

This annex introduces three most commonly available test sites, an Anechoic Chamber, an Anechoic Chamber with a ground plane and an Open Area Test Site (OATS), which may be used for radiated tests. These test sites are generally referred to as free field test sites. Both absolute and relative measurements can be performed in these sites. Where absolute measurements are to be carried out, the chamber should be verified. A detailed verification procedure is described in ETSI TR 102 273 [3] relevant parts 2, 3 and 4.

NOTE: To ensure reproducibility and traceability of radiated measurements only these test sites should be used in measurements in accordance with the present document.

B.1.1 Anechoic chamber

An anechoic chamber is an enclosure, usually shielded, whose internal walls, floor and ceiling are covered with radio absorbing material, normally of the pyramidal urethane foam type. The chamber usually contains an antenna support at one end and a turntable at the other. A typical anechoic chamber is shown in figure B.1.

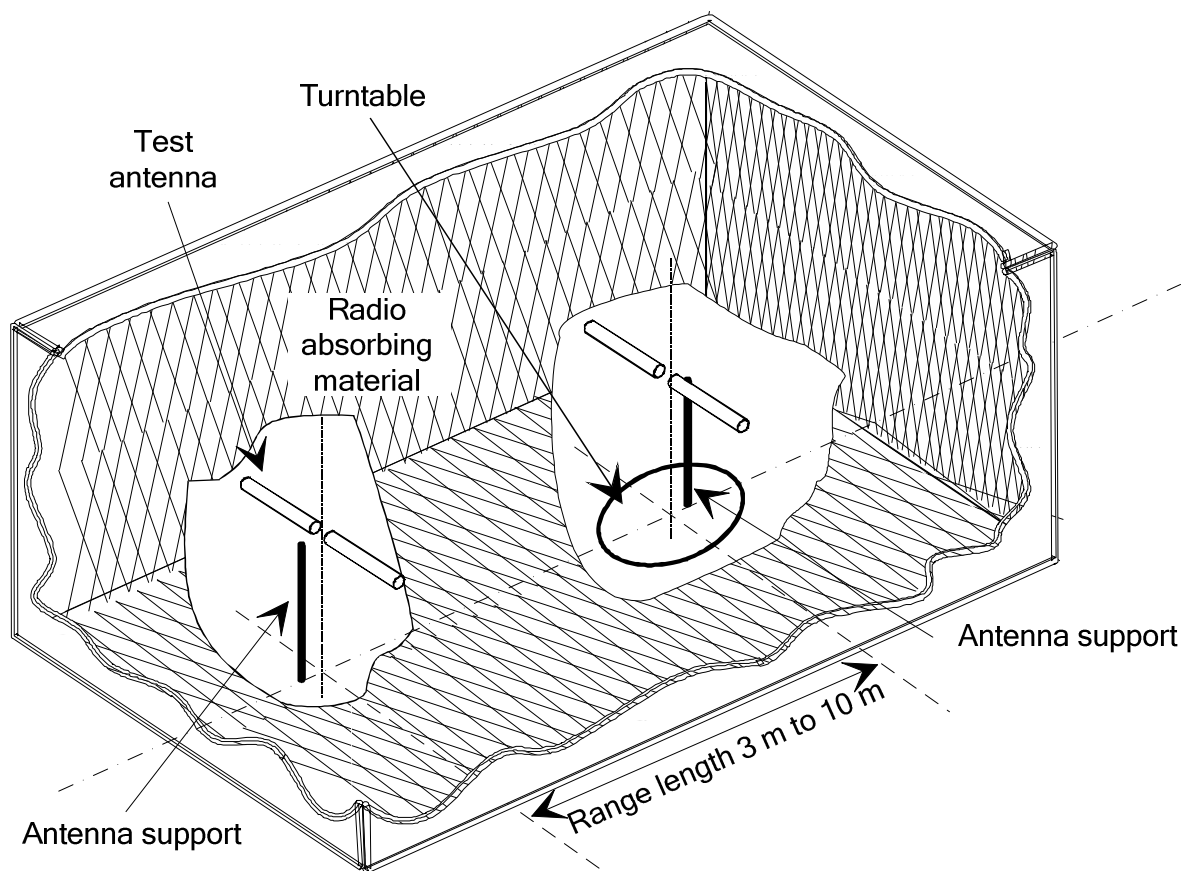

Figure B.1: A typical anechoic chamber

The chamber shielding and radio absorbing material work together to provide a controlled environment for testing purposes. This type of test chamber attempts to simulate free space conditions.

The shielding provides a test space, with reduced levels of interference from ambient signals and other outside effects, whilst the radio absorbing material minimizes unwanted reflections from the walls and ceiling which can influence the measurements. In practice it is relatively easy for shielding to provide high levels (80 dB to 140 dB) of ambient interference rejection, normally making ambient interference negligible.

A turntable is capable of rotation through 360° in the horizontal plane and it is used to support the test sample (EUT) at a suitable height (e.g. 1 m) above the ground plane. The chamber shall be large enough to allow the measuring distance of at least 3 m or $2(d_1 + d_2)^2/\lambda$ (m), whichever is greater (see to clause B.2.5). The distance used in actual measurements shall be recorded with the test results.

The anechoic chamber generally has several advantages over other test facilities. There is minimal ambient interference, minimal floor, ceiling and wall reflections and it is independent of the weather. It does however have some disadvantages which include limited measuring distance and limited lower frequency usage due to the size of the pyramidal absorbers. To improve low frequency performance, a combination structure of ferrite tiles and urethane foam absorbers is commonly used.

All types of emission, sensitivity and immunity testing can be carried out within an Anechoic Chamber without limitation.

B.1.2 Anechoic chamber with a conductive ground plane

An anechoic chamber with a conductive ground plane is an enclosure, usually shielded, whose internal walls and ceiling are covered with radio absorbing material, normally of the pyramidal urethane foam type. The floor, which is metallic, is not covered and forms the ground plane. The chamber usually contains an antenna mast at one end and a turntable at the other. A typical anechoic chamber with a conductive ground plane is shown in figure B.2.

This type of test chamber attempts to simulate an ideal Open Area Test Site whose primary characteristic is a perfectly conducting ground plane of infinite extent.

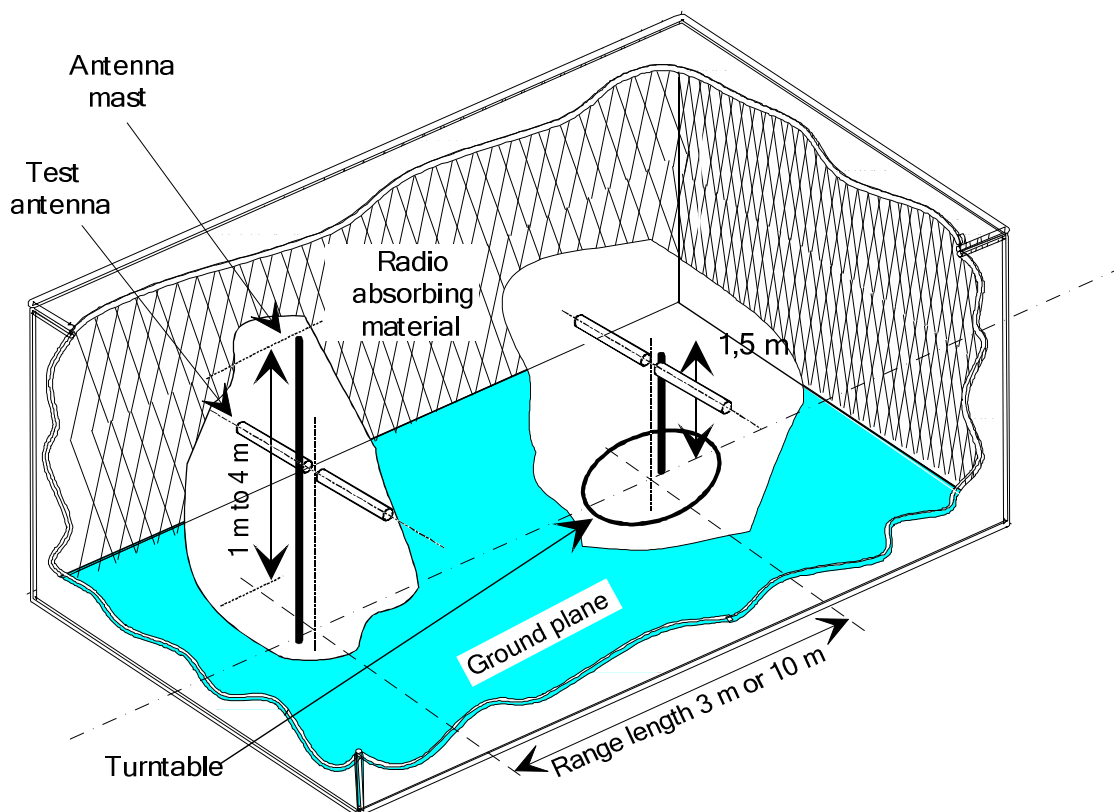

Figure B.2: A typical anechoic chamber with a conductive ground plane

In this facility the ground plane creates the wanted reflection path, such that the signal received by the receiving antenna is the sum of the signals from both the direct and reflected transmission paths. This creates a unique received signal level for each height of the transmitting antenna (or EUT) and the receiving antenna above the ground plane.

The antenna mast provides a variable height facility (from 1 to 4 metres) so that the position of the test antenna can be optimized for maximum coupled signal between antennas or between a EUT and the test antenna.

A turntable is capable of rotation through 360° in the horizontal plane and it is used to support the test sample (EUT) at a specified height, usually 1,5 metres above the ground plane. The chamber shall be large enough to allow the measuring distance of at least 3 m or $2(d_1 + d_2)/\lambda$ (m), whichever is greater (see clause B.2.5). The distance used in actual measurements shall be recorded with the test results.

Emission testing involves firstly "peaking" the field strength from the EUT by raising and lowering the receiving antenna on the mast (to obtain the maximum constructive interference of the direct and reflected signals from the EUT) and then rotating the turntable for a "peak" in the azimuth plane. At this height of the test antenna on the mast, the amplitude of the received signal is noted. Secondly the EUT is replaced by a substitution antenna (positioned at the EUT's phase or volume centre) which is connected to a signal generator. The signal is again "peaked" and the signal generator output adjusted until the level, noted in stage one, is again measured on the receiving device.

Receiver sensitivity tests over a ground plane also involve "peaking" the field strength by raising and lowering the test antenna on the mast to obtain the maximum constructive interference of the direct and reflected signals, this time using a measuring antenna which has been positioned where the phase or volume centre of the EUT will be during testing. A transform factor is derived. The test antenna remains at the same height for stage two, during which the measuring antenna is replaced by the EUT. The amplitude of the transmitted signal is reduced to determine the field strength level at which a specified response is obtained from the EUT.

B.1.3 Open Area Test Site (OATS)

An Open Area Test Site comprises a turntable at one end and an antenna mast of variable height at the other end above a ground plane which, in the ideal case, is perfectly conducting and of infinite extent. In practice, while good conductivity can be achieved, the ground plane size has to be limited. A typical Open Area Test Site is shown in figure B.3.

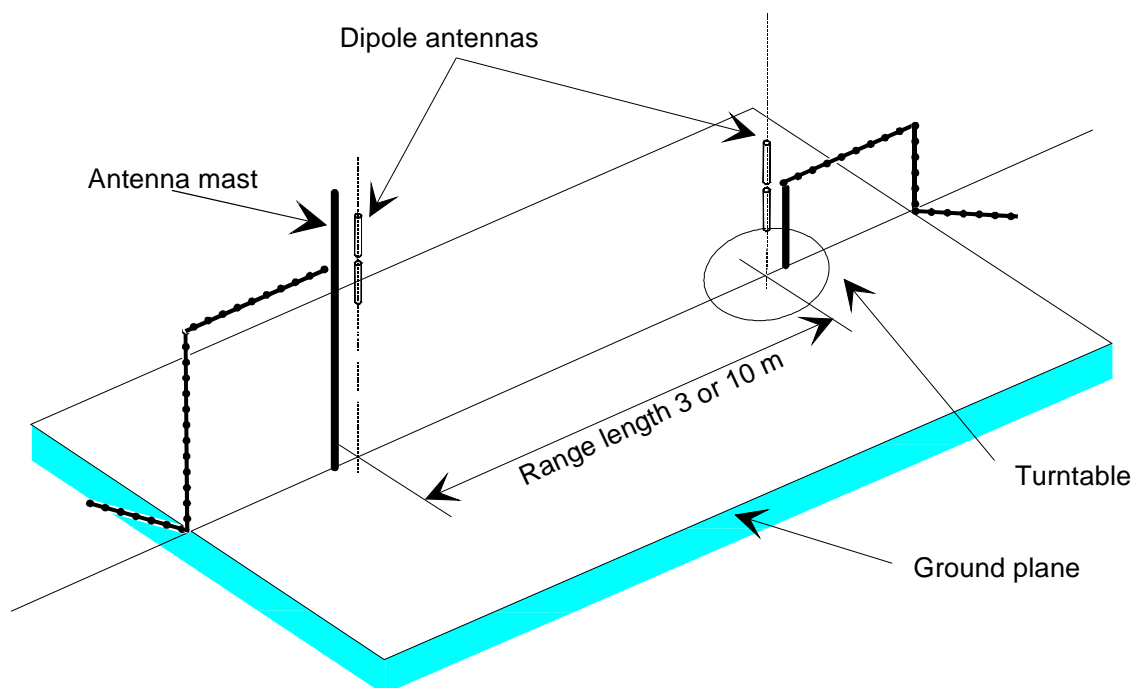

Figure B.3: A typical Open Area Test Site

The ground plane creates a wanted reflection path, such that the signal received by the receiving antenna is the sum of the signals received from the direct and reflected transmission paths. The phasing of these two signals creates a unique received level for each height of the transmitting antenna (or EUT) and the receiving antenna above the ground plane.

Site qualification concerning antenna positions, turntable, measurement distance and other arrangements are same as for anechoic chamber with a ground plane. In radiated measurements an OATS is also used by the same way as anechoic chamber with a ground plane.

Typical measuring arrangement common for ground plane test sites is presented in the figure B.4.

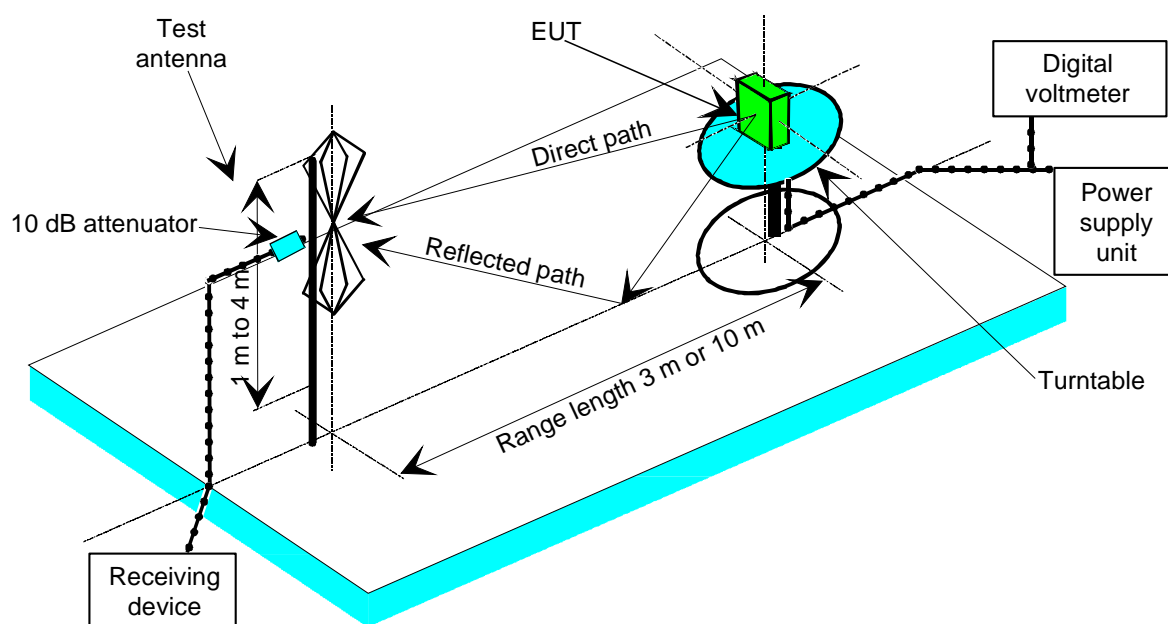

Figure B.4: Measuring arrangement on ground plane test site (OATS set-up for spurious emission testing)

B.1.4 Test antenna

A test antenna is always used in radiated test methods. In emission tests (i.e. frequency error, effective radiated power, spurious emissions and adjacent channel power) the test antenna is used to detect the field from the EUT in one stage of the measurement and from the substitution antenna in the other stage. When the test site is used for the measurement of receiver characteristics (i.e. sensitivity and various immunity parameters) the antenna is used as the transmitting device.

The test antenna should be mounted on a support capable of allowing the antenna to be used in either horizontal or vertical polarization which, on ground plane sites (i.e. Anechoic Chambers with ground planes and Open Area Test Sites), should additionally allow the height of its centre above the ground to be varied over the specified range (usually 1 to 4 metres).

In the frequency band 30 MHz to 1 000 MHz, dipole antennas (constructed in accordance with ANSI C63.5 [4]) are generally recommended. For frequencies of 80 MHz and above, the dipoles should have their arm lengths set for resonance at the frequency of test. Below 80 MHz, shortened arm lengths are recommended. For spurious emission testing, however, a combination of biconical antennas (commonly termed "bicones" and log periodic dipole array antennas (commonly termed "log periodics") could be used to cover the entire 30 MHz to 1 000 MHz band. Above 1 000 MHz, waveguide horns are recommended although, again, log periodics could be used.

NOTE: The gain of a horn antenna is generally expressed relative to an isotropic radiator.

B.1.5 Substitution antenna

The substitution antenna is used to replace the EUT for tests in which a transmitting parameter (i.e. frequency error, effective radiated power, spurious emissions and adjacent channel power) is being measured. For measurements in the frequency band 30 MHz to 1 000 MHz, the substitution antenna should be a dipole antenna (constructed in accordance with ANSI C63.5 [4]). For frequencies of 80 MHz and above, the dipoles should have their arm lengths set for resonance at the frequency of test. Below 80 MHz, shortened arm lengths are recommended. For measurements above 1 000 MHz, a waveguide horn is recommended. The centre of this antenna should coincide with either the phase centre or volume centre.

B.1.6 Measuring antenna

The measuring antenna is used in tests on a EUT in which a receiving parameter (i.e. sensitivity and various immunity tests) is being measured. Its purpose is to enable a measurement of the electric field strength in the vicinity of the EUT. For measurements in the frequency band 30 MHz to 1 000 MHz, the measuring antenna should be a dipole antenna (constructed in accordance with ANSI C63.5 [4]). For frequencies of 80 MHz and above, the dipoles should have their arm lengths set for resonance at the frequency of test. Below 80 MHz, shortened arm lengths are recommended. The centre of this antenna should coincide with either the phase centre or volume centre (as specified in the test method) of the EUT.

B.2 Guidance on the use of radiation test sites

B.2.0 General

This clause details procedures, test equipment arrangements and verification that should be carried out before any of the radiated test are undertaken. These schemes are common to all types of test sites described in annex B.

B.2.1 Verification of the test site

No test should be carried out on a test site which does not possess a valid certificate of verification. The verification procedures for the different types of test sites described in annex B (i.e. Anechoic Chamber, Anechoic Chamber with a ground plane and Open Area Test Site) are given in ETSI TR 102 273 [3] parts 2, 3 and 4, respectively.

B.2.2 Preparation of the EUT

The supplier should supply information about the EUT covering the operating frequency, polarization, supply voltage(s) and the reference face. Additional information, specific to the type of EUT should include, where relevant, carrier power, channel separation, whether different operating modes are available (e.g. high and low power modes) and if operation is continuous or is subject to a maximum test duty cycle (e.g. 1 minute on, 4 minutes off).

Where necessary, a mounting bracket of minimal size should be available for mounting the EUT on the turntable. This bracket should be made from low conductivity, low relative dielectric constant (i.e. less than 1,5) material(s) such as expanded polystyrene, balsawood, etc.

B.2.3 Power supplies to the EUT

All tests should be performed using power supplies wherever possible, including tests on EUT designed for battery-only use. In all cases, power leads should be connected to the EUT's supply terminals (and monitored with a digital voltmeter) but the battery should remain present, electrically isolated from the rest of the equipment, possibly by putting tape over its contacts.

The presence of these power cables can, however, affect the measured performance of the EUT. For this reason, they should be made to be "transparent" as far as the testing is concerned. This can be achieved by routing them away from the EUT and down to the either the screen, ground plane or facility wall (as appropriate) by the shortest possible paths. Precautions should be taken to minimize pick-up on these leads (e.g. the leads could be twisted together, loaded with ferrite beads at 0,15 metre spacing or otherwise loaded).

B.2.4 Range length

The range length for all these types of test facility should be adequate to allow for testing in the far-field of the EUT i.e. it should be equal to or exceed:

$$\frac{2(d_1 + d_2)^2}{\lambda}$$

Where:

- d_1 is the largest dimension of the EUT/dipole after substitution (m);

- d_2 is the largest dimension of the test antenna (m);
- λ is the test frequency wavelength (m).

It should be noted that in the substitution part of this measurement, where both test and substitution antennas are half wavelength dipoles, this minimum range length for far-field testing would be:

$$2\lambda$$

It should be noted in test reports when either of these conditions is not met so that the additional measurement uncertainty can be incorporated into the results.

NOTE 1: For the fully anechoic chamber, no part of the volume of the EUT should, at any angle of rotation of the turntable, fall outside the "quiet zone" of the chamber at the nominal frequency of the test.

NOTE 2: The "quiet zone" is a volume within the Anechoic Chamber (without a ground plane) in which a specified performance has either been proven by test, or is guaranteed by the designer/supplier. The specified performance is usually the reflectivity of the absorbing panels or a directly related parameter (e.g. signal uniformity in amplitude and phase). It should be noted however that the defining levels of the quiet zone tend to vary.

NOTE 3: For the anechoic chamber with a ground plane, a full height scanning capability, i.e. 1 to 4 metres, should be available for which no part of the test antenna should come within 1 metre of the absorbing panels. For both types of Anechoic Chamber, the reflectivity of the absorbing panels should not be worse than -5 dB.

NOTE 4: For both the anechoic chamber with a ground plane and the Open Area Test Site, no part of any antenna should come within 0,25 metre of the ground plane at any time throughout the tests. Where any of these conditions cannot be met, measurements should not be carried out.

B.2.5 Site preparation

The cables for both ends of the test site should be routed horizontally away from the testing area for a minimum of 2 metres (unless, in the case both types of anechoic chamber, a back wall is reached) and then allowed to drop vertically and out through either the ground plane or screen (as appropriate) to the test equipment. Precautions should be taken to minimize pick up on these leads (e.g. dressing with ferrite beads, or other loading). The cables, their routing and dressing should be identical to the verification set-up.

NOTE: For ground reflection test sites (i.e. anechoic chambers with ground planes and Open Area Test Sites) which incorporate a cable drum with the antenna mast, the 2 metres requirement may be impossible to comply with.

Calibration data for all items of test equipment should be available and valid. For test, substitution and measuring antennas, the data should include gain relative to an isotropic radiator (or antenna factor) for the frequency of test. Also, the VSWR of the substitution and measuring antennas should be known.

The calibration data on all cables and attenuators should include insertion loss and VSWR throughout the entire frequency range of the tests. All VSWR and insertion loss figures should be recorded in the log book results sheet for the specific test.

Where correction factors/tables are required, these should be immediately available.

For all items of test equipment, the maximum errors they exhibit should be known along with the distribution of the error e.g.:

- cable loss: $\pm 0,5$ dB with a rectangular distribution;
- measuring receiver: 1,0 dB (standard deviation) signal level accuracy with a Gaussian error distribution.

At the start of measurements, system checks should be made on the items of test equipment used on the test site.

B.3 Coupling of signals

B.3.1 General

The presence of leads in the radiated field may cause a disturbance of that field and lead to additional measurement uncertainty. These disturbances can be minimized by using suitable coupling methods, offering signal isolation and minimum field disturbance (e.g. optical and acoustic coupling).

B.3.2 Data signals

Isolation can be provided by the use of optical, ultrasonic or infra-red means. Field disturbance can be minimized by using a suitable fibre optic connection. ultrasonic or infra-red radiated connections require suitable measures for the minimization of ambient noise.

Annex C (normative): Spectrum analyser specification

Methods of measurement in clauses 7.3 to 7.6 refer to the use of a spectrum analyser. The characteristics of the spectrum analyser shall meet at least the following requirements:

- the reading accuracy of the frequency marker shall be within ± 100 Hz;
- the accuracy of relative amplitude measurements shall be within $\pm 3,5$ dB;
- detector modes supported: Positive Peak and rms;

and if used for measurement in clause 7.4:

- frequency range: 9 kHz to 4 GHz (9 kHz to 12,75 GHz for equipment capable of operating at frequencies greater than 470 MHz).

It shall be possible to adjust the spectrum analyser to allow the separation on its screen of two equal amplitude components with a frequency difference of 500 Hz.

For statistically distributed modulations, the spectrum analyser and the integrating device (when appropriate) needs to allow determination of the power spectral density (energy per time and bandwidth), which has to be integrated over the bandwidth in question.

The spectrum analyser should have a dynamic range greater than 90 dB and the average phase noise in the adjacent and alternate channels shall be such that measurement of adjacent and alternate channel power (see clause 7.3) is not limited by phase noise. In order to confirm this the selected measurement technique for clause 7.3.2 shall be used to measure the adjacent and alternate channel power with a CW signal source with average phase noise of less than -120 dBc/Hz at one CSP offset and -125 dBc/Hz at two CSP offset. The maximum adjacent channel power observed with these conditions shall not exceed -65 dBc, and the maximum alternate channel power measured with these conditions shall not exceed -70 dBc.

Annex D (informative): Change History

Date	Version	Information about changes
June 2015	0.0.1	Revision under RE-D. Version 1.4.1.0.0.1 prepared by STF 493

History

Document history		
V1.1.1	February 2008	Publication
V1.2.1	December 2009	Publication
V1.3.2	October 2014	Publication
V2.1.0	December 2015	EN Approval Procedure AP 20160320: 2015-12-21 to 2016-03-21
V2.1.1	March 2016	Publication