

Draft **ETSI EN 302 510-1** V1.1.1 (2006-05)

---

*European Standard (Telecommunications series)*

**Electromagnetic compatibility  
and Radio spectrum Matters (ERM);  
Radio equipment in the frequency range  
30 MHz to 37,5 MHz for Ultra Low Power Active  
Medical Membrane Implants and Accessories;  
Part 1: Technical characteristics and test methods**

---



---

Reference

DEN/ERM-TG30-003-1

---

Keywords

radio, SRD, testing

**ETSI**

650 Route des Lucioles  
F-06921 Sophia Antipolis Cedex - FRANCE

Tel.: +33 4 92 94 42 00 Fax: +33 4 93 65 47 16

Siret N° 348 623 562 00017 - NAF 742 C  
Association à but non lucratif enregistrée à la  
Sous-Préfecture de Grasse (06) N° 7803/88

---

**Important notice**

Individual copies of the present document can be downloaded from:

<http://www.etsi.org>

The present document may be made available in more than one electronic version or in print. In any case of existing or perceived difference in contents between such versions, the reference version is the Portable Document Format (PDF). In case of dispute, the reference shall be the printing on ETSI printers of the PDF version kept on a specific network drive within ETSI Secretariat.

Users of the present document should be aware that the document may be subject to revision or change of status. Information on the current status of this and other ETSI documents is available at

<http://portal.etsi.org/tb/status/status.asp>

If you find errors in the present document, please send your comment to one of the following services:

[http://portal.etsi.org/chaicor/ETSI\\_support.asp](http://portal.etsi.org/chaicor/ETSI_support.asp)

---

**Copyright Notification**

No part may be reproduced except as authorized by written permission.  
The copyright and the foregoing restriction extend to reproduction in all media.

© European Telecommunications Standards Institute 2006.  
All rights reserved.

**DECT**<sup>TM</sup>, **PLUGTESTS**<sup>TM</sup> and **UMTS**<sup>TM</sup> are Trade Marks of ETSI registered for the benefit of its Members.  
**TIPHON**<sup>TM</sup> and the **TIPHON logo** are Trade Marks currently being registered by ETSI for the benefit of its Members.  
**3GPP**<sup>TM</sup> is a Trade Mark of ETSI registered for the benefit of its Members and of the 3GPP Organizational Partners.

# Contents

|  |    |
|--|----|
| Intellectual Property Rights .....   | 6  |
| Foreword.....  | 6  |
| 1 Scope .....  | 7  |
| 2 References .....   | 8  |
| 3 Definitions, symbols and abbreviations .....   | 8  |
| 3.1 Definitions .....  | 8  |
| 3.2 Symbols.....   | 9  |
| 3.3 Abbreviations .....  | 9  |
| 4 Technical requirements & specifications .....  | 10 |
| 4.1 General requirements .....   | 10 |
| 4.1.1 Receiver classification .....  | 10 |
| 4.1.2 General performance criteria .....   | 10 |
| 4.2 Presentation of equipment for testing purposes.....  | 10 |
| 4.2.1 Choice of model for testing .....  | 11 |
| 4.2.2 Testing of equipment that does not have an external 50 Ohm RF connector (integral antenna equipment) ..... | 11 |
| 4.2.2.1 Equipment with an internal permanent or temporary antenna connector.....                                 | 11 |
| 4.2.2.2 Equipment with a temporary antenna connector.....  | 11 |
| 4.3 Mechanical and electrical design.....  | 11 |
| 4.3.1 General.....   | 11 |
| 4.3.2 Controls .....   | 11 |
| 4.3.3 Transmitter shut-off facility .....  | 11 |
| 4.3.4 Receiver power save capability .....   | 12 |
| 4.3.5 Marking (equipment identification).....  | 12 |
| 4.4 Declarations by the applicant .....  | 12 |
| 4.5 Auxiliary test equipment .....   | 12 |
| 4.6 Interpretation of the measurement results .....  | 12 |
| 5 Test conditions, power sources and ambient temperatures .....  | 12 |
| 5.1 Normal and extreme test conditions .....   | 12 |
| 5.2 Test power source.....   | 13 |
| 5.2.1 External test power source.....  | 13 |
| 5.2.2 Internal test power source .....   | 13 |
| 5.3 Normal test conditions.....  | 13 |
| 5.3.1 Normal temperature and humidity.....   | 13 |
| 5.3.2 Normal test power source .....   | 14 |
| 5.3.2.1 Mains voltage .....  | 14 |
| 5.3.2.2 Regulated lead-acid battery power sources .....  | 14 |
| 5.3.2.3 Other power sources.....   | 14 |
| 5.4 Extreme test conditions .....  | 14 |
| 5.4.1 Extreme temperatures .....   | 14 |
| 5.4.1.1 Procedure for tests at extreme temperatures.....   | 14 |
| 5.4.1.1.1 Procedure for equipment designed for continuous operation .....  | 14 |
| 5.4.1.1.2 Procedure for equipment designed for intermittent operation .....                                      | 15 |
| 5.4.1.2 Extreme temperature ranges.....  | 15 |
| 5.4.2 Extreme test source voltages.....  | 15 |
| 5.4.2.1 Mains voltage.....   | 15 |
| 5.4.2.2 Regulated lead-acid battery power sources .....  | 16 |
| 5.4.2.3 Power sources using other types of batteries.....  | 16 |
| 5.4.2.4 Other power sources.....   | 16 |
| 6 General conditions.....  | 16 |
| 6.1 Normal test signals and test modulation.....   | 16 |
| 6.1.1 Normal test signals for data .....   | 16 |
| 6.2 Antenna .....  | 17 |

|   |   |           |
|---|---|-----------|
| 6.2.1   | Artificial Antenna .....  | 17        |
| 6.3   | Test fixture .....  | 17        |
| 6.3.1   | Alternate test fixture for equipment adjacent to the body or intended to be implanted within a human body ..... | 18        |
| 6.4   | Test sites and general arrangements for radiated measurements .....   | 18        |
| 6.5   | Modes of operation of the transmitter .....   | 18        |
| 6.6   | Measuring receiver .....  | 18        |
| 7   | Transmitter requirements .....  | 18        |
| 7.1   | Transmitter definitions .....   | 19        |
| 7.2   | Effective radiated power .....  | 19        |
| 7.2.1   | Radiated E-field .....  | 19        |
| 7.2.2   | Definition .....  | 19        |
| 7.2.3   | Methods of measurement .....  | 19        |
| 7.2.4   | Limits .....  | 20        |
| 7.3   | Out of Band Emissions .....   | 20        |
| 7.3.1   | Definition .....  | 20        |
| 7.3.2   | Method of measurement .....   | 20        |
| 7.3.3   | Limits .....  | 21        |
| 7.4   | Spurious emissions .....  | 21        |
| 7.4.1   | Definition .....  | 21        |
| 7.4.2   | Radiated field strength .....   | 21        |
| 7.4.3   | Limit .....   | 22        |
| 7.5   | Duty cycle .....  | 22        |
| 7.5.1   | Definitions .....   | 22        |
| 7.5.2   | Declaration .....   | 22        |
| 7.5.3   | Duty cycle limit .....  | 22        |
| 8   | Receiver requirement .....  | 23        |
| 8.1   | Blocking or desensitization .....   | 23        |
| 8.1.1   | Definition .....  | 23        |
| 8.1.2   | Methods of measurement .....  | 23        |
| 8.1.3   | Limits .....  | 24        |
| 8.2   | Receiver spurious radiation .....   | 24        |
| 8.2.1   | Definition .....  | 24        |
| 8.2.2   | Methods of measurement .....  | 24        |
| 8.2.3   | Limits .....  | 25        |
| 9   | Measurement uncertainty .....   | 25        |
| <b>Annex A (normative): Radiated measurement.....</b> |   | <b>26</b> |
| A.1   | Test sites and general arrangements for measurements involving the use of radiated fields .....                 | 26        |
| A.1.1   | Anechoic Chamber .....  | 26        |
| A.1.2   | Anechoic Chamber with a conductive ground plane .....   | 27        |
| A.1.3   | Open Area Test Site (OATS) .....  | 28        |
| A.1.4   | Human torso simulator for use with active medical implant membrane transmitters .....                           | 29        |
| A.1.4   | Test antenna .....  | 31        |
| A.1.5   | Substitution antenna .....  | 31        |
| A.1.6   | Measuring antenna .....   | 31        |
| A.1.7   | Stripline arrangement .....   | 31        |
| A.1.7.1   | General .....   | 31        |
| A.1.7.2   | Description .....   | 31        |
| A.1.7.3   | Calibration .....   | 32        |
| A.1.7.4   | Mode of use .....   | 32        |
| A.2   | Guidance on the use of radiation test sites .....   | 32        |
| A.2.1   | Verification of the test site .....   | 32        |
| A.2.2   | Preparation of the EUT .....  | 32        |
| A.2.3   | Power supplies to the EUT .....   | 32        |
| A.2.4   | Volume control setting for analogue speech tests .....  | 32        |
| A.2.5   | Range length .....  | 33        |
| A.2.6   | Site preparation .....  | 33        |

|                               |  |           |
|-------------------------------|--|-----------|
| A.3                           | Coupling of signals.....                                   | 34        |
| A.3.1                         | General .....  | 34        |
| A.3.2                         | Data Signals.....  | 34        |
| A.3.3                         | Speech and analogue signals .....                          | 34        |
| A.3.3.1                       | Acoustic coupler description.....                          | 34        |
| A.3.3.2                       | Calibration .....  | 35        |
| A.4                           | Standard test position .....                               | 35        |
| A.5                           | Test fixture .....   | 35        |
| A.5.1                         | Description .....  | 35        |
| A.5.2                         | Calibration.....   | 36        |
| A.5.3                         | Mode of use.....   | 37        |
| <b>Annex B (normative):</b>   | <b>Specification for measurement filter.....</b>           | <b>38</b> |
| <b>Annex C (normative):</b>   | <b>Technical performance of the spectrum analyser.....</b> | <b>40</b> |
| <b>Annex D (informative):</b> | <b>Bibliography.....</b>                                   | <b>41</b> |
| History .....                 |  | 42        |

---

## Intellectual Property Rights

IPRs essential or potentially essential to the present document may have been declared to ETSI. The information pertaining to these essential IPRs, if any, is publicly available for **ETSI members and non-members**, and can be found in ETSI SR 000 314: "*Intellectual Property Rights (IPRs); Essential, or potentially Essential, IPRs notified to ETSI in respect of ETSI standards*", which is available from the ETSI Secretariat. Latest updates are available on the ETSI Web server (<http://webapp.etsi.org/IPR/home.asp>).

Pursuant to the ETSI IPR Policy, no investigation, including IPR searches, has been carried out by ETSI. No guarantee can be given as to the existence of other IPRs not referenced in ETSI SR 000 314 (or the updates on the ETSI Web server) which are, or may be, or may become, essential to the present document.

---

## Foreword

This European Standard (Telecommunications series) has been produced by ETSI Technical Committee Electromagnetic compatibility and Radio spectrum Matters (ERM), and is now submitted for the Public Enquiry phase of the ETSI standards Two-step Approval Procedure.

For non-EU countries the present document may be used for regulatory (Type Approval) purposes.

The present document is part 1 of a multi-part deliverable covering inductively coupled Ultra Low Power Active Medical Implant Membrane (ULP-AMI-M) devices in the frequency range 30 MHz to 37,5 MHz, as identified below:

**Part 1:** "Technical characteristics and test methods";

Part 2: "Harmonized EN covering essential requirements of article 3.2 of the R&TTE Directive".

| <b>Proposed national transposition dates</b>   |                                 |
|--|---------------------------------|
| Date of latest announcement of this EN (doa):  | 3 months after ETSI publication |
| Date of latest publication of new National Standard or endorsement of this EN (dop/e): | 6 months after doa              |
| Date of withdrawal of any conflicting National Standard (dow):                         | 6 months after doa              |

# 1 Scope

The present document applies to Ultra Low Power Active Medical membrane implant transmitters and receiver/activators operating in the range from 30 MHz to 37,5 MHz and any associated radio apparatus including patient related telecommunication devices using digital modulation techniques.

The present document contains the technical characteristics for radio equipment and is referenced in CEPT/ERC/Recommendation 70-03 [1] and ERC Decisions.

The present document does not necessarily include all the characteristics which may be required by a user, nor does it necessarily represent the optimum performance achievable. It is a product standard which may be completely or partially superseded by specific standards covering specific applications.

The present document applies to ULP-AMI equipment conforming to the following:

- implantable membrane technology;
- external equipment with an antenna connection and/or with an integral antenna;
- for use as telecommunications and/or telecommand transmission to/from active medical membrane implant.

ULP-AMI equipment has an inherent safety of human life implication, manufacturers and users are cautioned to pay particular attention to the potential for interference from other systems operating in the same or adjacent bands.

The present document covers physician operated programmer/controller transmitters (typically fixed stations), patient operated external transmitters (fixed or mobile stations) and implanted radio transmitting devices (portable stations).

All types of membrane implant technology for radio devices are covered by the present document, provided the requirements of clause 7 are met.

The radio equipment, covered by the classification SRD is divided into multiple categories based on maximum radiated field strength or output power (see table 1). The power level designation for membrane technology in CEPT/ERC/Recommendation 70-03 [1] and ERC Decisions is specified in table 1.

**Table 1: Maximum radiated power**

| ERP power level |
|-----------------|
| 1 milliwatt     |

On non-harmonized parameters, national administrations may impose conditions on the type of modulation, frequency, channel/frequency separations, maximum transmitter radiated field strength/maximum output current to a defined antenna, duty cycle, equipment marking and the inclusion of an automatic transmitter shut-off facility, as a condition for the issue of an individual or general licence, or as a condition for use under licence exemption.

The measuring method defined in the present document measures the radiated E-field.

Additional standards or specifications may be required for equipment such as that intended for connection to the Public Switched Telephone Network (PSTN).

---

## 2 References

The following documents contain provisions which, through reference in this text, constitute provisions of the present document.

- References are either specific (identified by date of publication and/or edition number or version number) or non-specific.
- For a specific reference, subsequent revisions do not apply.
- For a non-specific reference, the latest version applies.

Referenced documents which are not found to be publicly available in the expected location might be found at <http://docbox.etsi.org/Reference>.

- [1] CEPT/ERC/Recommendation 70-03 (2002): "Relating to the use of Short Range Devices (SRD)".
- [2] ITU-T Recommendation O.153: "Basic parameters for the measurement of error performance at bit rates below the primary rate".
- [3] RADIOFREQUENCY RADIATION DOSIMETRY HANDBOOK (October 1986), USAF School of Aerospace Medicine, Aerospace Medical Division (AFSC), Brooks Air Force Base, TX 78235-5301.
- [4] ETSI TR 100 028 (V1.3.1): "Electromagnetic compatibility and Radio spectrum Matters (ERM); Uncertainties in the measurement of mobile radio equipment characteristics".
- [5] ETSI TR 102 273-1-1 (V1.2.1): "Electromagnetic compatibility and Radio spectrum Matters (ERM); Improvement on Radiated Methods of Measurement (using test site) and evaluation of the corresponding measurement uncertainties Part 1: Uncertainties in the measurement of mobile radio equipment characteristics; Sub-part 1: Introduction".

---

## 3 Definitions, symbols and abbreviations

### 3.1 Definitions

For the purposes of the present document, the following terms and definitions apply:

**Active Implantable Medical Device (AIMD):** any Active Medical Device (AMD) which is intended to be totally or partially introduced, surgically or medically, into the human body or by medical intervention into a natural orifice, and which is intended to remain after the procedure

**Active Medical Device (AMD):** any medical device relying for its functioning on a source of electrical energy or any source of power other than that directly generated by the human body or gravity

**artificial antenna:** tuned reduced-radiating dummy load equal to the nominal impedance specified by the applicant

**conducted measurements:** measurements which are made using a direct connection to the equipment under test

**custom antenna:** antenna built according to manufacturers antenna design rules

**dedicated antenna:** removable antenna supplied and tested with the radio equipment, designed as an indispensable part of the equipment

**integral antenna:** permanent fixed antenna, which may be built-in, that is designed as an indispensable part of the equipment

**medical implant membrane device (ULP-AMI-M):** active medical implant device with resonant transmission capability, that operates in a ULP-AMI band and is placed inside the human body for the purpose of performing diagnostic functions and/or delivery of therapeutic treatment



**medical implant membrane programmer/control transmitter:** a transmitter, operating outside of a human body in a ULP-AMI frequency band that transmits to and receives information from a membrane implant for the purpose of determining pressure within the human body

**programmer/controller:** ULP-AMI-P equipment used by a physician to communicate with an implanted device

**radiated measurements:** measurements which involve the absolute measurement of a radiated field

**telecommand:** use of radio communication for the transmission of signals to initiate, modify or terminate functions of equipment at a distance

**telemetry:** use of radio communication for indicating or recording data at a distance

**Ultra Low Power Active Medical Implant (ULP-AMI):** the radio part of an AIMD

**Ultra Low Power Active Medical Implant Peripheral (ULP-AMI-P) device:** the radio part of equipment outside the human body that communicates with an ULP-AMI.

## 3.2 Symbols

For the purposes of the present document, the following symbols apply:

|                |  |
|----------------|--|
| E              | Electrical field strength                          |
| E <sub>o</sub> | Reference electrical field strength, (see annex A) |
| f              | Frequency  |
| P              | Power  |
| R              | Distance   |
| R <sub>o</sub> | Reference distance, (see annex A)                  |
| t              | Time   |

## 3.3 Abbreviations

For the purposes of the present document, the following abbreviations apply:

|           |   |
|-----------|---|
| EMC       | ElectroMagnetic Compatibility                               |
| ERP       | Effective Radiated Power                                    |
| RF        | Radio Frequency   |
| R&TTE     | Radio and Telecommunications Terminal Equipment             |
| SRD       | Short Range Device  |
| ULP-AMI   | Ultra-Low Power Active Medical Implant                      |
| ULP-AMI-M | Ultra Low Power Active Medical Implant Membrane transmitter |
| VSWR      | Voltage Standing Wave Ratio                                 |

---

# 4 Technical requirements & specifications

## 4.1 General requirements

### 4.1.1 Receiver classification

The product family of ULP-AMI radio devices is divided into three Equipment Classes, see table 2, each having its own set of minimum performance criteria. This classification is based upon the impact on persons in case the equipment does not operate above the specified minimum performance level. Applicable equipment classification shall be specified by the manufacturer.

Table 2

| Receiver class  | Relevant receiver clauses | Risk assessment of receiver performance  |
|---|---------------------------|--|
| 1   | 8.1                       | Highly reliable ULP-AMI communication media;<br>e.g. serving human life inherent systems<br>(may result in a physical risk to a person)      |
| 2   | 8.1                       | Medium reliable ULP-AMI communication media<br>e.g. causing Inconvenience to persons, which cannot<br>simply be overcome by other means      |
| 3   | 8.1.1                     | Standard reliable ULP-AMI communication media<br>e.g. Inconvenience to persons, which can simply be<br>overcome by other means (e.g. manual) |
| NOTE: In particular where an ULP-AMI-M which may have an inherent safety of human life implication, manufacturers and users should pay particular attention to the potential for interference from other systems operating in the same or adjacent bands. |                           |  |

### 4.1.2 General performance criteria

For the purpose of the receiver performance tests, the receiver will produce an appropriate output under normal conditions as indicated below. Where the indicated performance cannot be achieved or if it is defined differently, the manufacturer shall declare and publish the performance criteria used to determine the performance of the receiver.

## 4.2 Presentation of equipment for testing purposes

Each equipment submitted for testing shall fulfil the requirements of the present document on all frequencies over which it is intended to operate. For implanted membrane devices having their power source external to the body, test must be conducted on both devices concurrently.

The applicant shall declare the operating frequency, the range of operating conditions and power requirements in consultation with the accredited laboratory, as applicable, to establish the appropriate test conditions.

Additionally, technical documentation and operating manuals, sufficient to make the test, shall be supplied.

A test fixture for equipment with an integral antenna may be supplied by the applicant (see clauses 6.3). For equipment supplied with an external antenna the applicant shall provide the antenna and a suitable test fixture as needed. In general, compliance must be shown by performing radiated electric field strength measurements.

If an equipment is designed to operate with different radiated field strengths or power levels, measurement of each transmitter parameter shall be performed, according to the present document, on samples of equipment defined in clause 4.2.1.

To simplify and harmonize the testing procedures between different testing laboratories, measurements shall be performed, according to the present document, on samples defined in clause 4.2.1.

### 4.2.1 Choice of model for testing

The applicant shall provide one or more samples of the equipment, as appropriate for testing.

Stand alone equipment shall be offered by the applicant complete with any ancillary equipment needed for testing.

If an equipment has several optional features, considered not to affect the RF parameters then the tests need only to be performed on the equipment configured with that combination of features considered to be the most complex, as proposed by the applicant and agreed by the test laboratory.

In the case of integral or dedicated antenna equipment, if the equipment does not have an internal permanent 50  $\Omega$  connector then it is permissible to supply a second sample of the equipment with a temporary antenna connector fitted to facilitate testing, see clause 4.2.2.

## 4.2.2 Testing of equipment that does not have an external 50 Ohm RF connector (integral antenna equipment)

This type of equipment will normally be tested by performing radiated tests at 3 meters. For devices with very low radiated field levels, measurements may be made at closer distance and the levels extrapolated to 3 meters using an inverse linear extrapolation rate.

### 4.2.2.1 Equipment with an internal permanent or temporary antenna connector

The means to access and/or implement the internal permanent or temporary antenna connector shall be stated by the applicant with the aid of a diagram. The fact that use has been made of the internal antenna connection, or of a temporary connection, to facilitate measurements shall be recorded in the test report.

### 4.2.2.2 Equipment with a temporary antenna connector

The applicant may submit one set of equipment with the normal antenna connected, to enable radiated measurements to be made. The applicant shall attend the test laboratory at the conclusion of the radiated measurements, to disconnect the antenna and fit the temporary connector if needed. The testing laboratory staff shall not connect or disconnect any temporary antenna connector.

Alternatively, the applicant may submit two sets of equipment to the test laboratory, one fitted with a temporary antenna connector with the antenna disconnected and another equipment with the antenna connected. Each equipment shall be used for the appropriate tests. The applicant shall declare that the two sets of equipment are identical in all aspects except for the antenna connector.

## 4.3 Mechanical and electrical design

### 4.3.1 General

The equipment submitted by the applicant should be designed, constructed and manufactured in accordance with sound engineering practice and with the aim of minimizing harmful interference to other equipment and services.

Transmitters and receivers may be individual or combination units.

### 4.3.2 Controls

Those controls which, if maladjusted, might increase the interfering potentialities of the equipment should not be easily accessible to the user.

### 4.3.3 Transmitter shut-off facility

If the transmitter is equipped with an automatic transmitter shut-off facility, it should be made inoperative for the duration of the test.

### 4.3.4 Receiver power save capability

If the receiver is equipped with a battery-saving circuit, this circuit should be made inoperative for the duration of the tests.

### 4.3.5 Marking (equipment identification)

The equipment shall be marked in a visible place. This marking shall be legible and durable. Where this is not possible due to physical size restrictions or factors associated with the intended functioning of the device, the marking shall be included in the user's manual. AIMD may also have a unique electronic identification that prevents unauthorized access to the telecommand and telemetry functions of the ULP-AMI.

## 4.4 Declarations by the applicant

When submitting equipment for testing, the applicant shall supply the necessary information required by the appropriate application form.

The performance of the equipment submitted for testing shall be representative of the performance of the corresponding production model.

## 4.5 Auxiliary test equipment

All necessary test signal sources, test fixtures, specialized test apparatus and set-up information shall accompany the equipment when it is submitted for testing unless alternative arrangements are agreed to by the test house and the manufacturer.

## 4.6 Interpretation of the measurement results

The interpretation of the results recorded on the appropriate test report for the measurements described in the present document shall be as follows:

- the measured value, determined by extrapolation if needed, relating to the corresponding limit shall be used to decide whether an equipment meets the requirements of the present document;
- the measurement uncertainty value for the measurement of each parameter shall be included in the test report;
- the recorded value of the measurement uncertainty shall, for each measurement, be equal to, or lower than, the figures in the table of measurement uncertainty (clause 9).

---

# 5 Test conditions, power sources and ambient temperatures

## 5.1 Normal and extreme test conditions

Testing shall be made under normal test conditions, and also, where stated, under extreme test conditions. It should be noted that emissions test on active medical implant membrane systems may at the option of the manufacturer be performed using the human torso simulator (artificial) filled with the tissue substitute material at nominal room temperature or in situ (using a human volunteer). The purpose is to facilitate testing at the measurement facility in a manner that simulates the intended usage in the manner the equipment is specified by the manufacturer to be used. Measured emission levels are not expected to vary significantly from the levels measured at the nominal temperature and the normal body temperature of 37°C.

The test conditions and procedures shall be as specified in clauses 5.2 to 5.4.

## 5.2 Test power source

The equipment shall be tested using the appropriate test power source provided by the manufacturer as specified in clauses 5.2.1 or 5.2.2. Where equipment can be powered using either external or internal power sources, then the equipment shall be tested using the external power source as specified in clause 5.2.1 then repeated using the internal power source as specified in clause 5.2.2.

The test power source used shall be stated in the test report.

## 5.2.1 External test power source

During tests, the power source of the equipment shall be replaced by an external test power source capable of producing normal and extreme test voltages as specified in clauses 5.3.2 and 5.4.2. The internal impedance of the external test power source shall be low enough for its effect on the test results to be negligible. For the purpose of the tests, the voltage of the external test power source shall be measured at the input terminals of the equipment. The external test power source shall be suitably de-coupled as close to the equipment battery terminals as practicable. For radiated measurements any external power leads should be so arranged so as not to affect the measurements.

During tests the test power source voltages shall be within a tolerance of  $< \pm 1$  % relative to the voltage at the beginning of each test. The value of this tolerance can be critical for certain measurements. Using a smaller tolerance will provide a better uncertainty value for these measurements.

## 5.2.2 Internal test power source

For radiated measurements on portable equipment with integral antenna, fully charged internal batteries should be used. The batteries used should be as supplied or recommended by the applicant. If internal batteries are used, at the end of each test the voltage shall be within a tolerance of  $< \pm 5$  % relative to the voltage at the beginning of each test. For portable devices where the batteries cannot be measured or replaced but have telemetry readout of battery voltage, it is acceptable to record the starting and ending voltages as provided by the telemetry readout. This shall be stated in the test report.

If appropriate, for conducted measurements or where a test fixture is used, an external power supply at the required voltage may replace the supplied or recommended internal batteries. This shall be stated on the test report.

Equipment intended to be implanted in a human body may be hermetically sealed or packaged in a manner where it may not be possible to measure the battery or other voltage source directly or indirectly. For this type of equipment, it is not necessary to measure the voltage; however, care shall be taken to ensure that the internal power supply voltage does not fall below the manufacturer's specification for normal operating voltage range.

## 5.3 Normal test conditions

### 5.3.1 Normal temperature and humidity

The normal temperature and humidity conditions for tests for devices external to the human body shall be any convenient combination of temperature and humidity within the following ranges:

- temperature             $+15^{\circ}\text{C}$  to  $+37^{\circ}\text{C}$ ;
- relative humidity    20 % to 75 %.

Active medical implant transmitters operate after implant in a human body. Accordingly, the body tends to serve as an oven to maintain the implant temperature near  $37^{\circ}\text{C}$ . Therefore, the normal temperature and humidity conditions for implant transmitters shall be within the following ranges:

- temperature             $+36^{\circ}\text{C}$  to  $+38^{\circ}\text{C}$ ;
- relative humidity    not applicable.

When it is impracticable to carry out tests under these conditions, a note to this effect, stating the ambient temperature and relative humidity during the tests, shall be added to the test report.

### 5.3.2 Normal test power source

#### 5.3.2.1 Mains voltage

The normal test voltage for equipment to be connected to the mains shall be the nominal mains voltage. For the purpose of the present document, the nominal voltage shall be the declared voltage, or any of the declared voltages, for which the equipment was designed.

The frequency of the test power source corresponding to the ac mains shall be between 49 Hz and 51 Hz.

### 5.3.2.2 Regulated lead-acid battery power sources

When any peripheral device or radio equipment that is part of a membrane implant system is intended for operation with the usual types of regulated lead-acid battery power sources, the normal test voltage shall be 1,1 multiplied by the nominal voltage of the battery (e.g. 6 V, 12 V etc.).

### 5.3.2.3 Other power sources

For operation from other power sources or types of battery (primary or secondary), the normal test voltage shall be that declared by the equipment applicant and agreed by the accredited test laboratory. Such values shall be stated in the test report.

## 5.4 Extreme test conditions

### 5.4.1 Extreme temperatures

#### 5.4.1.1 Procedure for tests at extreme temperatures

Before measurements are made the equipment shall have reached thermal balance in the test chamber. The equipment shall be switched off during the temperature stabilizing period.

In the case of equipment containing temperature stabilization circuits designed to operate continuously, the temperature stabilization circuits shall be switched on for 15 minutes after thermal balance has been obtained, and the equipment shall then meet the specified requirements.

If the thermal balance is not checked by measurements, a temperature stabilizing period of at least one hour, or such period as may be decided by the accredited test laboratory, shall be allowed. The sequence of measurements shall be chosen, and the humidity content in the test chamber shall be controlled so that excessive condensation does not occur.

If the equipment is incapable of transmitting an unmodulated carrier, an actual digital data sequence or a pseudorandom sequence representative of an actual digital data transmission shall be used to modulate the carrier (see clauses 6.1 and 6.1.1).

##### 5.4.1.1.1 Procedure for equipment designed for continuous operation

If the applicant states that the equipment is designed for continuous operation, the test procedure shall be as follows:

- before conducting tests at the upper extreme temperature the equipment shall be placed in the test chamber and left until thermal balance is attained. The equipment shall then be switched on in the transmit condition for a period of time specified by the manufacturer to be the maximum time the equipment will transmit in normal operation after which the equipment shall meet the specified requirements;
- for tests at the lower extreme temperature, the equipment shall be left in the test chamber until thermal balance is attained, then switched on for a period of one minute after which the equipment shall meet the specified requirements.

##### 5.4.1.1.2 Procedure for equipment designed for intermittent operation

If the applicant states that the equipment is designed for intermittent operation, the test procedure shall be as follows:

- before tests at the upper extreme temperature the equipment shall be placed in the test chamber and left until thermal balance is attained in the oven. The equipment shall then either:
  - transmit on and off according to the applicants declared duty cycle for a period of five minutes; or
  - if the applicant's declared on period exceeds one minute, then transmit in the on condition for a period not exceeding one minute, followed by a period in the off or standby mode for four minutes; after which the equipment shall meet the specified requirements;

- for tests at the lower extreme temperature, the equipment shall be left in the test chamber until thermal balance is attained, then switched to the standby or receive condition for one minute after which the equipment shall meet the specified requirements.

### 5.4.1.2 Extreme temperature ranges

For tests at extreme temperatures, measurements shall be made in accordance with the procedures specified in clause 5.4.1.1, at the upper and lower temperatures of one of the following ranges:

**Table 3: Extreme temperature ranges**

|   |                |
|---|----------------|
| Category I (General):   | -20°C to +55°C |
| Category II (Portable equipment for outdoor use):   | -10°C to +55°C |
| Category III (Equipment for normal indoor use) (see note 1):  | 0°C to +55°C   |
| Category IV (Active Medical Implant membrane transmitters) (see note 2):  | +25°C to +45°C |
| <p>NOTE 1: The term "equipment for normal indoor use" is taken to mean that the room temperature is controlled and the minimum indoor temperature is equal to or greater than 5°C.</p> <p>NOTE 2: The term "Active Medical Implant membrane transmitters" refers only to equipment that is intended to be placed inside a human body during normal operation.<br/>The range of +25°C to +45°C is the core body temperature variation over which a human body can survive [3].</p> |                |

The manufacturer may define a different temperature range than specified above for any category provided the EUT meets the conditions set forth below. For specific applications, the manufacturer can specify wider temperature ranges than given as a minimum above. In this case the test report shall show compliance with the limits in the present document over the extended ranges specified by the manufacturer. This shall be reflected in the manufacturers' product literature. Narrower temperature ranges than given above may be implemented provided the reduced range is reflected in the manufacturer's product literature and the test report shows that the device implements techniques which do not allow it to exceed the limits specified in the present document over the minimum ranges given above.

The equipment shall comply with all the technical requirements of the present document at all times when operating within the boundary limits of the required operational temperature profile.

For special applications, the manufacturer can specify wider temperature ranges than given as a minimum above. This shall be reflected in the manufacturer's product literature.

The test report shall state which range is used.

## 5.4.2 Extreme test source voltages

### 5.4.2.1 Mains voltage

The extreme test voltages for equipment to be connected to an ac mains source shall be the nominal mains voltage  $\pm 10\%$ . For equipment operating over a range of mains voltages clause 5.4.2.4 applies.

### 5.4.2.2 Regulated lead-acid battery power sources

When any peripheral device or radio equipment that is part of a membrane implant system is intended for operation from the usual type of regulated lead-acid battery power sources the extreme test voltages shall be 1,3 and 0,9 multiplied by the nominal voltage of the battery (6 V, 12 V, etc.).

For float charge applications using "gel-cell" type batteries the extreme voltage shall be 1,15 and 0,85 multiplied by the nominal voltage of the declared battery voltage.

### 5.4.2.3 Power sources using other types of batteries

The lower extreme test voltages for equipment with power sources using batteries shall be as follows:

- for equipment with a battery indicator, the end point voltage as indicated;
- for equipment without a battery indicator the following end point voltages shall be used:
  - a) for the Leclanché or the lithium type of battery:
    - 0,85 multiplied by the nominal voltage of the battery;
  - b) for the nickel-cadmium type of battery:
    - 0,9 multiplied the nominal voltage of the battery;
- for other types of battery or equipment, the lower extreme test voltage for the discharged condition shall be declared by the equipment applicant.

The nominal voltage is considered to be the upper extreme test voltage in this case.

### 5.4.2.4 Other power sources

For equipment using other power sources, or capable of being operated from a variety of power sources, the extreme test voltages shall be according to manufactures specification.

---

## 6 General conditions

The following clauses are written to define conditions for test together as a system or individual units to be separately tested. Systems or individual units should be tested in a position that approximates the normal operation to the extent possible. Where individual units have differing requirements, the test report shall list and identify the unit separately together with the information showing compliance with the applicable requirement.

### 6.1 Normal test signals and test modulation

The test modulating signal is a signal which modulates a carrier, is dependent upon the type of equipment under test and also the measurement to be performed. Modulation test signals only apply to products with an external modulation connector. For equipment without an external modulation connector, normal operating modulation shall be used.

#### 6.1.1 Normal test signals for data

Normal test signals for data are specified as follows:

- D-M2: a test signal representing a pseudo-random bit sequence of at least 511 bits in accordance with ITU-T Recommendation O.153 [2]. This sequence shall be continuously repeated. If the sequence cannot be continuously repeated, the actual method used shall be stated in the test report.
- D-M3: a test signal shall be agreed between the accredited test laboratory and the applicant in case selective messages are used and are generated or decoded within the equipment.  
The agreed test signal may be formatted and may contain error detection and correction.

For angle modulation, the normal level of the test signal D-M3 shall produce a deviation of 20 % of the channel separation or any other value as declared by the applicant as the normal operating level.

For other forms of modulation, the applicant will provide the modulation source as applicable.



## 6.2 Antenna

Equipment operating in the 30 MHz to 37,5 MHz band shall have an integral antenna, an external dedicated antenna or both. If provision for an external antenna connection is made, the connector shall be a unique type to prevent use of an antenna other than a dedicated antenna supplied by the manufacturer. The device will be configured as specified by the manufacturer in normal operation. Use of a human volunteer is acceptable if needed.

### 6.2.1 Artificial Antenna

An artificial antenna that simulates the actual antenna configuration specified by the applicant may be used only as necessary. The test laboratory and the manufacturer shall agree as to the arrangement.

## 6.3 Test fixture

With equipment intended for use with an integral antenna, and not equipped with a 50  $\Omega$  RF output connector, a suitable test fixture may be used as agreed with the accredited test laboratory, if radiated measurements with the intended antenna cannot be made.

This fixture is a RF coupling device for coupling the integral antenna to a 50  $\Omega$  RF terminal at the working frequencies of the equipment under test. This allows certain measurements to be performed using conducted measuring methods. However, only relative measurements may be performed. The test fixture is normally only required for extreme temperature measurements and shall be calibrated only with the equipment under test.

The test fixture shall be fully described by the applicant. The accredited test laboratory, where applicable shall calibrate the test fixture by carrying out the required field measurements at normal temperatures at the prescribed test site. Then the same measurements shall be repeated on the equipment under test using the test fixture for all identified frequency components.

In addition, the test fixture may provide:

- a connection to an external power supply;
- a connection to a data interface.

The performance characteristics of the test fixture shall be agreed upon with the accredited test laboratory, where applicable and shall conform to the following basic parameters:

- the circuit associated with the RF coupling shall contain no active or non linear devices;
- the coupling loss shall not influence the measuring results;
- the coupling loss shall be independent of the position of the test fixture and be unaffected by the proximity of the surrounding objects or people;
- the coupling loss shall be reproducible when the equipment under test is removed and replaced;
- the coupling loss shall remain substantially constant when the environmental conditions are varied.

### 6.3.1 Alternate test fixture for equipment adjacent to the body or intended to be implanted within a human body

For measurement purposes, to determine compliance with all emission limits, membrane implants may be tested in a fixture that approximates the physical conditions of an implanted transmitter placed in a human body or in a manner that places the equipment in the position relative to the human body as intended by the manufacturer via using a human volunteer. If using an artificial fixture, a human torso simulator may be used with the implant mounted inside. In this case it shall be filled with a tissue substitute material and placed on the radiated emissions test site turntable with the implant at a height of 1,5 meters above the ground plane for testing purposes. The tissue substitute material conductivity and dielectric parameters shall in accordance with clause A.1.4. Typically they will be equivalent to those of human muscle tissue at the fundamental frequency or alternatively these parameters may be adjusted to correspond to the measurement frequency. The tissue substitute material shall be sufficiently fluid that it will flow around the implant without creating any voids.

## 6.4 Test sites and general arrangements for radiated measurements

For guidance on radiation test sites, see annex A. Detailed descriptions of radiated measurement arrangements are included in this annex.

## 6.5 Modes of operation of the transmitter

For the purpose of the measurements according to the present document, there should preferably be a facility to operate the transmitter in an unmodulated state. The method of achieving an unmodulated carrier frequency or special types of modulation patterns may also be decided by agreement between the applicant and the accredited test laboratory. It shall be described in the test report. It may involve suitable temporary internal modifications of the equipment under test. If it is not possible to provide an unmodulated carrier then this shall be stated in the test report.

For the purpose of testing, the normal test signal, see clauses 6.1 and 6.1.1 shall be applied to the input of the transmitter under test with the normal input device disconnected when possible.

## 6.6 Measuring receiver

The term "measuring receiver" refers to a selective voltmeter or a spectrum analyser. The bandwidth and detector type of the measuring receiver are given in table 4. Measurements of all emissions up to 1 000 MHz are required.

**Table 4**

| Frequency (f)                                | Detector type | Bandwidth     |
|--|---------------|---------------|
| $9 \text{ kHz} \leq f < 150 \text{ kHz}$     | Quasi Peak    | 200 to 300 Hz |
| $150 \text{ kHz} \leq f < 30 \text{ MHz}$    | Quasi Peak    | 9 to 10 kHz   |
| $30 \text{ MHz} \leq f < 1\ 000 \text{ MHz}$ | Quasi Peak    | 120 kHz       |

Exceptionally, a different bandwidth may be used for narrow band signals if agreed with the accredited test laboratory. This shall be stated in the test report.

---

# 7 Transmitter requirements

To meet the requirements of the present document, the transmitter shall be measured as the radiated E-field. To the extent possible, the equipment shall be arranged in a manner as specified by the manufacturer in the instruction manual.

Where the membrane system transmitter is designed with an adjustable carrier E-field or RF current, all parameters shall be measured using the highest output level as declared by the applicant. The equipment shall then be adjusted to the lowest setting, as declared by the applicant, and the spurious emissions measurement shall be repeated (see clause 7.4).

When making transmitter tests on equipment designed for intermittent operation, the duty cycle of the transmitter, as declared by the applicant on the application form, shall not be exceeded. The actual duty cycle used shall be stated on the test report form.

If the equipment is supplied with an integral antenna and a permanent antenna connector to be used with a dedicated antenna, the following full tests shall be carried out using the integral antenna and the dedicated antenna connected to the external connector.

## 7.1 Transmitter definitions

Transmitters covered by the present document are considered to have internal and/or dedicated external antennas. In this case, radiated field strength measurements are required. User defined antenna systems are not permitted.

## 7.2 Effective radiated power

### 7.2.1 Radiated E-field

The provisions of this clause and subsequent clauses are applicable to devices designed to intentionally radiate an electric field.

### 7.2.2 Definition

The radiated E-field is defined as the E-field in the direction of maximum field strength under the specified conditions of measurement. This is defined for a transmitter with an integral or dedicated antenna.

### 7.2.3 Methods of measurement

This method applies to equipment with dedicated internal or external antenna and equipment with an external antenna connector. All supplied antennas must be tested.

On a test site, selected from annex A, the equipment shall be placed at the specified height on a non-conducting support and in the position closest to normal use as declared by the provider. Stepped or swept frequency systems shall be tested with the stepping or sweep disabled.

The transmitter antenna connector shall be connected to a supplied antenna either internally or externally. The test antenna shall be connected to a measuring receiver and orientated for vertical polarization and the length of the test antenna shall be chosen to correspond to the frequency of the measuring receiver.

In the case of pulse modulation the transmitter shall be switched on with test modulation D-M2.

If this is not possible, then the measurements shall be made with the transmitter modulated by the normal modulation or a test signal D-M3 (see clause 6.1.2) in which case the fact shall be recorded in the test report.

The measuring receiver shall be tuned to the fundamental emission frequency.

The test antenna shall be raised and lowered through the specified range of heights until a maximum signal level is detected on the measuring receiver.

The transmitter shall then be rotated through 360° in the horizontal plane, until the maximum signal level is detected by the measuring receiver and the test antenna height shall be adjusted again for maximum signal level.

The maximum signal level detected by the measuring receiver shall be noted.

The transmitter shall be replaced by a substitution antenna as defined in clauses A.1.4 and A.1.5.

The substitution antenna shall be orientated for vertical polarization and calibrated for the frequency of the emission.

The substitution antenna shall be connected to a calibrated signal generator.

The frequency of the calibrated signal generator shall be set to the frequency of the fundamental emission. The input attenuator setting of the measuring receiver shall be adjusted in order to increase the sensitivity of the measuring receiver, if necessary.

The test antenna shall be raised and lowered through the specified range of heights to ensure that the maximum signal is received.

When a test site according to clause A.1.1 is used, the height of the antenna need not be varied.

The input signal to the substitution antenna shall be adjusted to the level that produces a level detected by the measuring receiver, that is equal to the level noted while the emission was measured, corrected for any change of input attenuator setting of the measuring receiver.

The input level to the substitution antenna shall be recorded as a power level and this level is corrected to determine an average power level during the interval of transmission to determine compliance. The measurement shall be repeated with the test antenna and the substitution antenna orientated for horizontal polarization.

The measure of the effective radiated power is the larger of the two power levels recorded at the input to the substitution antenna, corrected for the gain of the substitution antenna if necessary.

If applicable, the measurements shall be repeated with the transmitter on standby. The transmitter radiated E-field is based on the use of a linearly polarized antenna.

The measuring bandwidth and detector type of the measurement receiver shall be in accordance with clause 6.6.

## 7.2.4 Limits

The maximum average power of an emission within the band 30 MHz to 37,5 MHz is 1 milliwatt. If the normal operational mode of the device uses stepped frequencies, the limit applies to the emission level of each frequency. Correction of the above power measurement by a factor determined by the duration of each pulse and the period of the pulse train at the measurement frequency is permitted.

## 7.3 Out of Band Emissions

The operational frequency band within the 30 MHz to 37,5 MHz band shall be stated by the applicant.

### 7.3.1 Definition

The modulation bandwidth contains all associated side bands above the spurious emission level that are outside the declared band in the range of 30 MHz to 37,5 MHz.

### 7.3.2 Method of measurement

The transmitter shall be connected to all manufacturer supplied antenna(s). The spectrum analyser shall be connected to a linearly polarized antenna placed at any convenient distance from the transmitter antenna.

The transmitter shall be operated at the nominal carrier power or field strength measured under normal test conditions in clause 7.2. The attenuator shall be adjusted to an appropriate level displayed at the spectrum analyser screen.

The transmitter shall be modulated with standard test modulation if applicable (see clauses 6.1 and 6.1.1). If the equipment cannot be modulated externally, the internal modulating signal shall be used.

For transmitters using a continuous wideband swept or stepped carrier the measurement shall be made with the sweep or stepping on.

The output of the transmitter, with or without test fixture, shall be measured by using a spectrum analyser with a resolution bandwidth appropriate to accept all major side bands. Normally this would be a resolution bandwidth setting of approximately 1 % of the 20 dB bandwidth. The power level calibration of the spectrum analyser shall then be related to the power level or field strength measured in clause 7.2. The calculation will be used to calculate the absolute level of the sideband power.

The test laboratory shall ensure that the spectrum analyser's span is sufficiently wide enough to ensure that the carrier and all its major side bands are captured.

The difference between the frequencies of the upper and lower points, where the displayed power envelope of the modulation including frequency drift is equal to the appropriate level defined in clause 7.3.1 is recorded as the modulation bandwidth.

### 7.3.3 Limits

Out of band emission limit is 0,01 milliwatt. If the normal operational mode of the device uses stepped frequencies, the limit applies to the emission level of each frequency within the declared band. Correction of peak power measurements by a factor determined by the duration of each individual pulse over the period of the pulse train is permitted.

## 7.4 Spurious emissions

### 7.4.1 Definition

Spurious emissions are emissions at frequencies other than those of the carrier and sidebands associated with normal test modulation (clause 6.1). The level of spurious emissions shall be measured only for frequencies above 25 MHz but not greater than 1 000 MHz at normal conditions (clause 5.3) as:

- 1) their effective radiated power or field strength when radiated by the cabinet with integral antenna, if applicable, and any other dedicated antenna supplied by the manufacturer.

### 7.4.2 Radiated field strength

This clause refers to clause 7.4.1; indent 1.

This method applies only to equipment with an external antenna connector or permanently connected antenna.

On a test site, selected from annex A, the equipment shall be placed at the specified height on a non-conducting support with the antenna and other apparatus in a position closest to normal use as declared by the provider.

If applicable, the transmitter antenna connector shall be connected to the antenna supplied with the unit. The test antenna shall be orientated for vertical polarization and the length of the test antenna shall be chosen to correspond to the instantaneous frequency of the measuring receiver. The output of the test antenna shall be connected to the measuring receiver.

In the case of pulse modulation the transmitter shall be switched on with test modulation D-M2.

If this is not possible, then the measurements shall be made with the transmitter modulated by the normal (internally generated modulation) signal or the test signal D-M3 (see clause 6.1.2) in which case the fact shall be recorded in the test report.

The measuring receiver shall be tuned over the frequency range 25 MHz to 1 GHz except for the channel on which the transmitter is intended to operate and any adjacent channels.

At each frequency at which a spurious component is detected, the test antenna shall be raised and lowered through the specified range of heights until a maximum signal level is detected on the measuring receiver.

The transmitter shall then be rotated through 360° in the horizontal plane, until the maximum signal level is detected by the measuring receiver and the test antenna height shall be adjusted again for maximum signal level.

The maximum signal level detected by the measuring receiver shall be noted.

The transmitter shall be replaced by a substitution antenna as defined in clauses A.1.4 and A.1.5.

The substitution antenna shall be orientated for vertical polarization and calibrated for the frequency of the spurious component detected.

The substitution antenna shall be connected to a calibrated signal generator.

The frequency of the calibrated signal generator shall be set to the frequency of the spurious component detected. The input attenuator setting of the measuring receiver shall be adjusted in order to increase the sensitivity of the measuring receiver, if necessary.

The test antenna shall be raised and lowered through the specified range of heights to ensure that the maximum signal is received.

When a test site according to clause A.1.1 is used, the height of the antenna need not be varied.

The input signal to the substitution antenna shall be adjusted to the level that produces a level detected by the measuring receiver, that is equal to the level noted while the spurious component was measured, corrected for any change of input attenuator setting of the measuring receiver.

The input level to the substitution antenna shall be recorded as a power level and this level is corrected to determine an average power level during the interval of transmission to determine compliance. The measurement shall be repeated with the test antenna and the substitution antenna orientated for horizontal polarization.

The measurement shall be repeated with the test antenna and the substitution antenna orientated for horizontal polarization.

The measure of the effective radiated power of the spurious components is the larger of the two power levels recorded for each spurious component at the input to the substitution antenna, corrected for the gain of the substitution antenna if necessary.

If applicable, the measurements shall be repeated with the transmitter on standby.

### 7.4.3 Limit

The spurious emission limit is 0,01 milliwatt. If the normal operational mode of the device uses stepped or swept frequencies, the limit applies to the emission level of each frequency. Correction of the above power measurements by a factor determined by the duration of each individual pulse over the period of the pulse train is permitted.

## 7.5 Duty cycle

### 7.5.1 Definitions

For the purpose of the present document the term duty cycle refers to the ratio of the total on time of the "message" to the total off time in any one hour period under repeated normal operation during the time measurement interval. The device may be triggered either automatically or manually and depending on how the device is triggered will also depend on whether the duty cycle is fixed or random.

### 7.5.2 Declaration

For software controlled or pre-programmed devices, the applicant shall declare the duty cycle class for the equipment under test, see table 5.

For manually activated or event dependant devices, with or without software controlled functions, the applicant shall declare whether the device once triggered, follows a pre-programmed cycle, or whether the transmission is constant until the activation mechanism is released or otherwise reset. The applicant shall also give a description of the application for the device and include a typical usage pattern for maximizing duty cycle that would occur in a period of 1 hour. The typical usage pattern as declared by the applicant shall be used to determine the duty cycle. Where an acknowledgement is required, the additional transmitter on-time shall be included and declared by the manufacturer.

### 7.5.3 Duty cycle limit

In a period of 1 hour the duty cycle shall not exceed 10 %.

---

## 8 Receiver requirement

### 8.1 Blocking or desensitization

#### 8.1.1 Definition

Blocking is a measure of the capability of the receiver to receive a wanted modulated signal without exceeding a given degradation due to the presence of an unwanted input signal at any frequencies other than those of the spurious responses adjacent selectivity. Class 3 receivers are exempt from this requirement.

#### 8.1.2 Methods of measurement

This measurement shall be conducted under normal conditions.

Two signal generators A and B shall be connected to the receiver via a combining network to the receiver either:

- a) via a test fixture or a test antenna that couples to the receiver integral or dedicated antenna; or
- b) via a test fixture directly to the receiver permanent or temporary antenna connector.

The method of coupling to the receiver shall be stated in the test report.

Signal generator A shall be at the nominal frequency of the receiver, with normal modulation of the wanted signal. Signal generator B shall be unmodulated and shall be adjusted to a test frequency above that of the upper band edge as defined below.

Initially signal generator B shall be switched off and by using signal generator A the minimum level giving sufficient response shall be established. The output level of generator A shall then be increased by 3 dB.

Signal generator B is then switched on and adjusted until the wanted criteria are met. For purposes of this test, the criteria are considered to be met as long as the receiver always protects the health and safety of the patient. For example, techniques that accomplish this may detect corrupted data and mark it as invalid data or the data link may cease functioning during this phase of the testing. The nature of the technique used to protect the patient and the level at which it functions to provide this protection shall be stated in the test report.

The frequency for generator B is defined by the following procedure:

Receiving upper band edge: highest operating receiver frequency + receiver bandwidth  
Receiving lower band edge: lowest operating receiver frequency - receiver bandwidth.

The receiver centre frequency and bandwidth may be measured or may be declared by the manufacturer.

For systems with swept operating frequencies:

Receiving upper band edge: high end of sweep range + receiver bandwidth  
Receiving lower band edge: low end of sweep range - receiver bandwidth.

The receiver bandwidth and sweeping range may be measured or may be declared by the manufacturer.

For blocking measurements above the receive frequency:

The frequency for generator B is calculated as the upper band edge plus an offset multiplier of the receiver bandwidth.

For blocking measurements below the receive frequency:

The frequency for generator B is calculated as the lower band edge minus an offset multiplier of the receiver bandwidth.

The blocking or desensitization shall be recorded as the ratio in dB of lowest level of the unwanted signal (generator B) to the level of the wanted signal (generator A).

### 8.1.3 Limits

The blocking level, for any frequency within the specified ranges, shall not be less than the values given in table 5, except at frequencies on which spurious responses are found. The limit value is determined by a reference limit (Ref) plus a correction factor (dB) depending of the appropriate receiver classification.

**Table 5**

| Receiver Classification  | Frequency offset (MHz) | Limit          |
|--|------------------------|----------------|
| 1  | All                    | $\geq -20$ dBm |
| 2  | $\pm 2$                | $\geq -69$ dBm |
|  | $\pm 10$               | $\geq -44$ dBm |
| NOTE: The limits are based on an antenna gain of +2 dBi. For other antenna gains greater than +2 dBi the limits shall be adjusted accordingly. |                        |                |

## 8.2 Receiver spurious radiation

These requirements do not apply to receivers used in combination with permanently co-located transmitters continuously transmitting. Co-located is defined as  $< 3$  m. In these cases the receivers will be tested together with the transmitter in operating mode (see clause 7.4).

### 8.2.1 Definition

Spurious radiation from receivers are emissions radiated from the antenna, the chassis and case of the receiver. It is specified as the radiated power of a discrete signal. Included in this definition are modulation products that are outside the 20 dB down point on either side of the fundamental emission.

### 8.2.2 Methods of measurement

This method applies to equipment with an external antenna connector or permanently connected antenna.

On a test site, selected from annex A, the equipment shall be placed at the specified height on a non-conducting support and in the position closest to normal use as declared by the provider. The receiver antenna connector shall be connected to an artificial antenna (see clause 6.2).

The test antenna shall be orientated for vertical polarization and the length of the test antenna shall be chosen to correspond to the instantaneous frequency of the measuring receiver. The output of the test antenna shall be connected to a measuring receiver. The receiver shall be switched on and the measuring receiver shall be tuned over the frequency range 25 MHz to 4 GHz. At each frequency at which a spurious component is detected, the test antenna shall be raised and lowered through the specified range of height until a maximum signal level is detected by the measuring receiver. When a test site according to clauses A.1.1 or A.1.2 is used, there is no need to vary the height of the antenna.

The transmitter shall then be rotated through  $360^\circ$  in the horizontal plane, until the maximum signal level is detected by the measuring receiver and the test antenna height shall be adjusted again for maximum signal level.

The maximum signal level detected by the measuring receiver shall be noted.

The receiver shall be replaced by a substitution antenna as defined in clause A.1.5.

The substitution antenna shall be orientated for vertical polarization and calibrated for the frequency of the spurious component detected.

The substitution antenna shall be connected to a calibrated signal generator.

The frequency of the calibrated signal generator shall be set to the frequency of the spurious component detected.

The input attenuator setting of the measuring receiver shall be adjusted in order to increase the sensitivity of the measuring receiver, if necessary.



The test antenna shall be raised and lowered through the specified range of height to ensure that the maximum signal is received. The input signal to the substitution antenna shall be adjusted to the level that produces a level detected by the measuring receiver, that is equal to the level noted while the spurious component was measured, corrected for any change of input attenuator setting of the measuring receiver. The input level to the substitution antenna shall be recorded as power level, corrected for any change of input attenuator setting of the measuring receiver.

The measurement shall be repeated with the test antenna and the substitution antenna orientated for horizontal polarization.

### 8.2.3 Limits

The power of any receiver spurious emission, radiated or conducted, shall not exceed the values given below:

The limits are applicable to all receiver classes.

- 2 nW below 1 000 MHz;

---

## 9 Measurement uncertainty

The interpretation of the results recorded in the test report for the measurements described in the present document shall be as follows:

- the measured value related to the corresponding limit shall be used to decide whether an equipment meets the requirements of the present document;
- the value of the measurement uncertainty for the measurement of each parameter shall be separately included in the test report;
- the value of the measurement uncertainty shall be, for each measurement, equal to or lower than the figures given below:

|                     |                        |
|---------------------|------------------------|
| RF frequency        | $\pm 1 \times 10^{-7}$ |
| RF power, conducted | $\pm 1$ dB             |
| RF power, radiated  | $\pm 6$ dB             |
| Temperature         | $\pm 1$ °C             |
| Humidity            | $\pm 5$ %              |

For the test methods, according to the present document the uncertainty figures shall be calculated according to the methods described in the TR 100 028 [4] and shall correspond to an expansion factor (coverage factor)  $k = 1,96$  or  $k = 2$  (which provide confidence levels of respectively 95 % and 95,45 % for the case where the distributions characterizing the actual measurement uncertainties are normal (Gaussian)).

The measurement uncertainties given above are based on such expansion factors.

The particular expansion factor used for the evaluation of the measurement uncertainty shall be stated.

## Annex A (normative): Radiated measurement

This annex has been drafted so that it could be used as well for the assessment of speech, data or equipment providing a specific response.

It covers test sites and methods to be used with integral antenna equipment or equipment having an antenna connector.

### A.1 Test sites and general arrangements for measurements involving the use of radiated fields

This annex introduces three most commonly available test sites, an anechoic chamber, an anechoic chamber with a ground plane and an Open Area Test Site (OATS), which may be used for radiated tests. These test sites are generally referred to as free field test sites. Both absolute and relative measurements can be performed in these sites. Where absolute measurements are to be carried out, the chamber should be verified. A detailed verification procedure is described in the relevant parts of TR 102 273-1-1 [5] or equivalent.

**NOTE:** To ensure reproducibility and tractability of radiated measurements only these test sites should be used in measurements in accordance with the present document.

#### A.1.1 Anechoic Chamber

An anechoic chamber is an enclosure, usually shielded, whose internal walls, floor and ceiling are covered with radio absorbing material, normally of the pyramidal urethane foam type. The chamber usually contains an antenna support at one end and a turntable at the other. A typical anechoic chamber is shown in figure A.1.

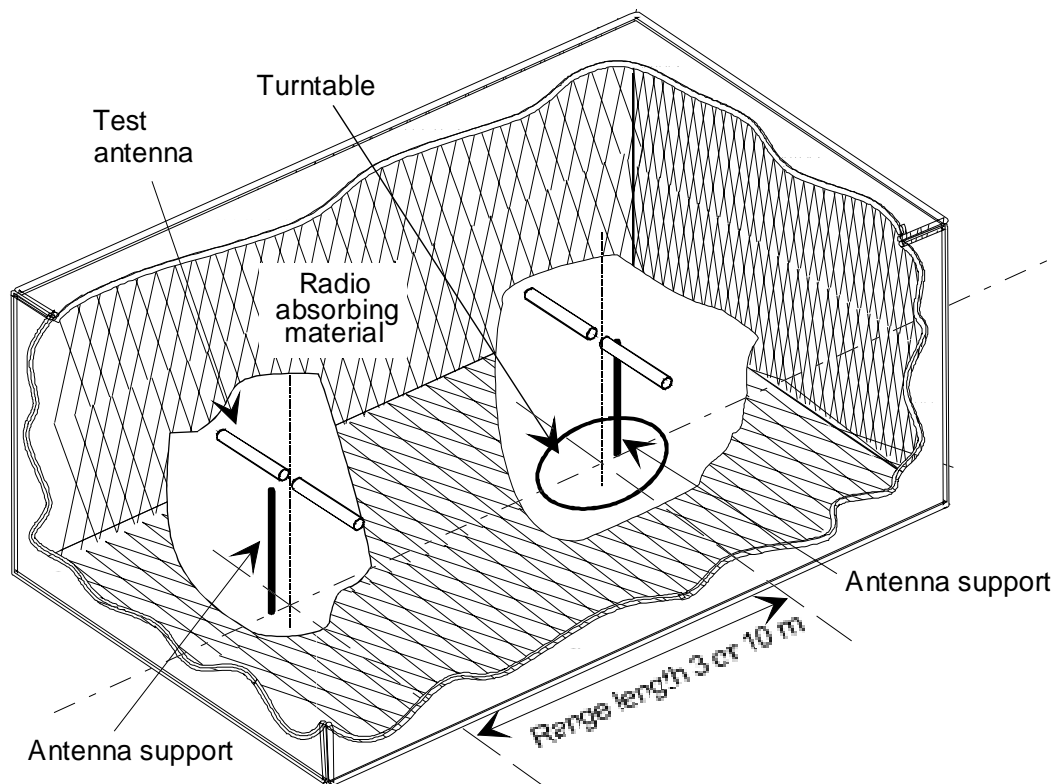

Figure A.1: A typical Anechoic Chamber

The chamber shielding and radio absorbing material work together to provide a controlled environment for testing purposes. This type of test chamber attempts to simulate free space conditions.

The shielding provides a test space, with reduced levels of interference from ambient signals and other outside effects, whilst the radio absorbing material minimizes unwanted reflections from the walls and ceiling which can influence the measurements. In practice it is relatively easy for shielding to provide high levels (80 dB to 140 dB) of ambient interference rejection, normally making ambient interference negligible.

A turntable is capable of rotation through 360° in the horizontal plane and it is used to support the test sample (EUT) at a suitable height (e.g. 1 m.) above the ground plane. The chamber shall be large enough to allow the measuring distance of at least 3 m or  $2(d_1+d_2)^2 / \lambda$  (m), whichever is greater (see to clause A.2.5). The distance used in actual measurements shall be recorded with the test results.

The anechoic chamber generally has several advantages over other test facilities. There is minimal ambient interference, minimal floor, ceiling and wall reflections and it is independent of the weather. It does however have some disadvantages which include limited measuring distance and limited lower frequency usage due to the size of the pyramidal absorbers. To improve low frequency performance, a combination structure of ferrite tiles and urethane foam absorbers is commonly used.

All types of emission, sensitivity and immunity testing can be carried out within an anechoic chamber without limitation.

## A.1.2 Anechoic Chamber with a conductive ground plane

An anechoic chamber with a conductive ground plane is an enclosure, usually shielded, whose internal walls and ceiling are covered with radio absorbing material, normally of the pyramidal urethane foam type. The floor, which is metallic, is not covered and forms the ground plane. The chamber usually contains an antenna mast at one end and a turntable at the other. A typical anechoic chamber with a conductive ground plane is shown in figure A.2.

This type of test chamber attempts to simulate an ideal Open Area Test Site whose primary characteristic is a perfectly conducting ground plane of infinite extent.

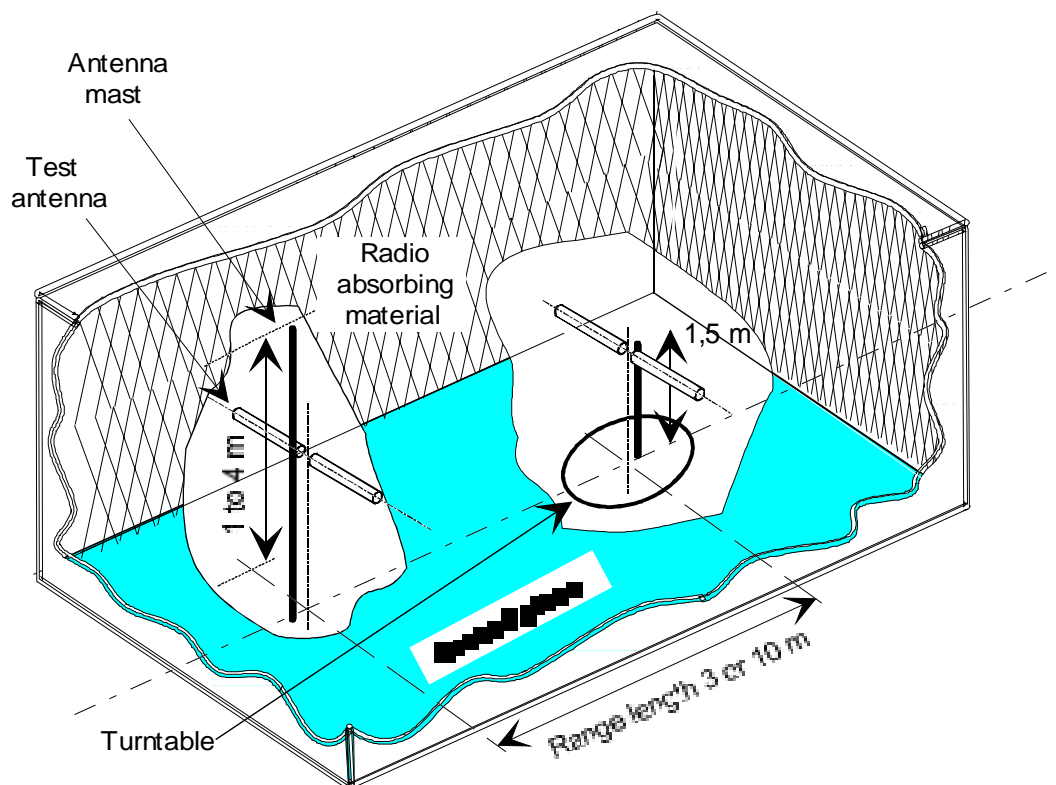

Figure A.2: A typical Anechoic Chamber with a conductive ground plane

In this facility the ground plane creates the wanted reflection path, such that the signal received by the receiving antenna is the sum of the signals from both the direct and reflected transmission paths. This creates a unique received signal level for each height of the transmitting antenna (or EUT) and the receiving antenna above the ground plane.

The antenna mast provides a variable height facility (from 1 m to 4 m) so that the position of the test antenna can be optimized for maximum coupled signal between antennas or between an EUT and the test antenna.

A turntable is capable of rotation through 360° in the horizontal plane and it is used to support the test sample (EUT) at a specified height, usually 1,5 m. above the ground plane. The chamber shall be large enough to allow the measuring distance of at least 3 m or  $2(d_1+d_2)^2/\lambda$  (m), whichever is greater (see clause A.2.5). The distance used in actual measurements shall be recorded with the test results.

Emission testing involves firstly "peaking" the field strength from the EUT by raising and lowering the receiving antenna on the mast (to obtain the maximum constructive interference of the direct and reflected signals from the EUT) and then rotating the turntable for a "peak" in the azimuth plane. At this height of the test antenna on the mast, the amplitude of the received signal is noted. Secondly the EUT is replaced by a substitution antenna (positioned at the EUT's phase or volume centre) which is connected to a signal generator. The signal is again "peaked" and the signal generator output adjusted until the level, noted in stage one, is again measured on the receiving device.

Receiver sensitivity tests over a ground plane also involve "peaking" the field strength by raising and lowering the test antenna on the mast to obtain the maximum constructive interference of the direct and reflected signals, this time using a measuring antenna which has been positioned where the phase or volume centre of the EUT will be during testing. A transform factor is derived. The test antenna remains at the same height for stage two, during which the measuring antenna is replaced by the EUT. The amplitude of the transmitted signal is reduced to determine the field strength level at which a specified response is obtained from the EUT.

### A.1.3 Open Area Test Site (OATS)

An Open Area Test Site comprises a turntable at one end and an antenna mast of variable height at the other end above a ground plane which, in the ideal case, is perfectly conducting and of infinite extent. In practice, whilst good conductivity can be achieved, the ground plane size has to be limited. A typical Open Area Test Site is shown in figure A.3.

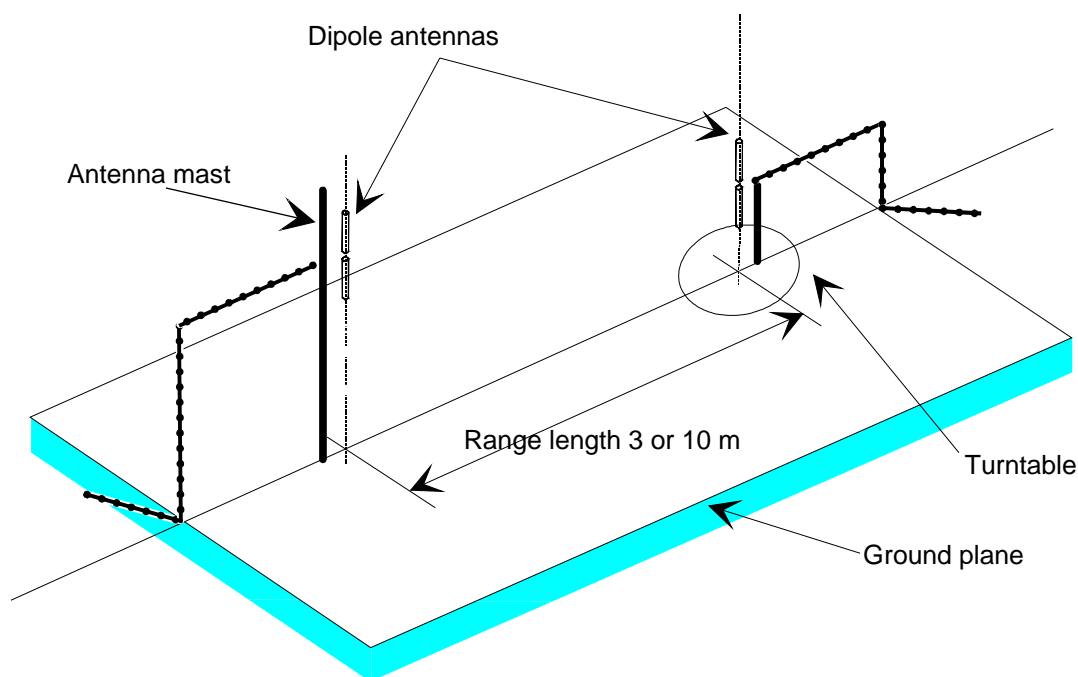
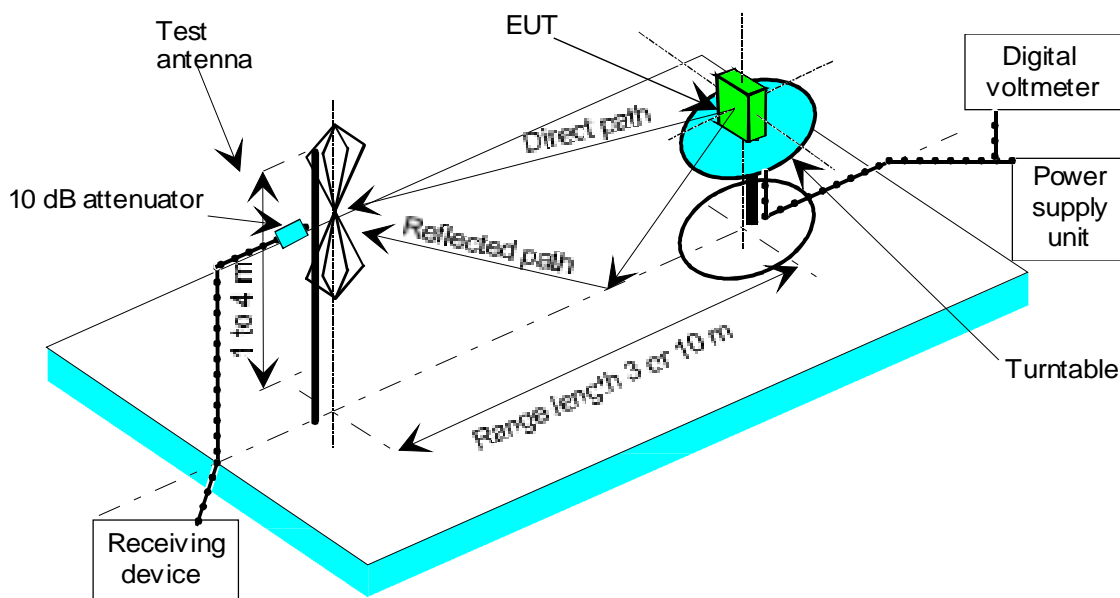

Figure A.3: A typical Open Area Test Site

The ground plane creates a wanted reflection path, such that the signal received by the receiving antenna is the sum of the signals received from the direct and reflected transmission paths. The phasing of these two signals creates a unique received level for each height of the transmitting antenna (or EUT) and the receiving antenna above the ground plane.

Site qualification concerning antenna positions, turntable, measurement distance and other arrangements are same as for anechoic chamber with a ground plane. In radiated measurements an OATS is also used by the same way as anechoic chamber with a ground plane.

Typical measuring arrangement common for ground plane test sites is presented in the figure A.4.



**Figure A.4: Measuring arrangement on ground plane test site (OATS set-up for spurious emission testing)**

#### A.1.4 Human torso simulator for use with active medical implant membrane transmitters

ULP-AMIs may be tested in a simulated man constructed as follows in order to simulate operation of the ULP-AMI under actual operation conditions as shown in figure A.5.

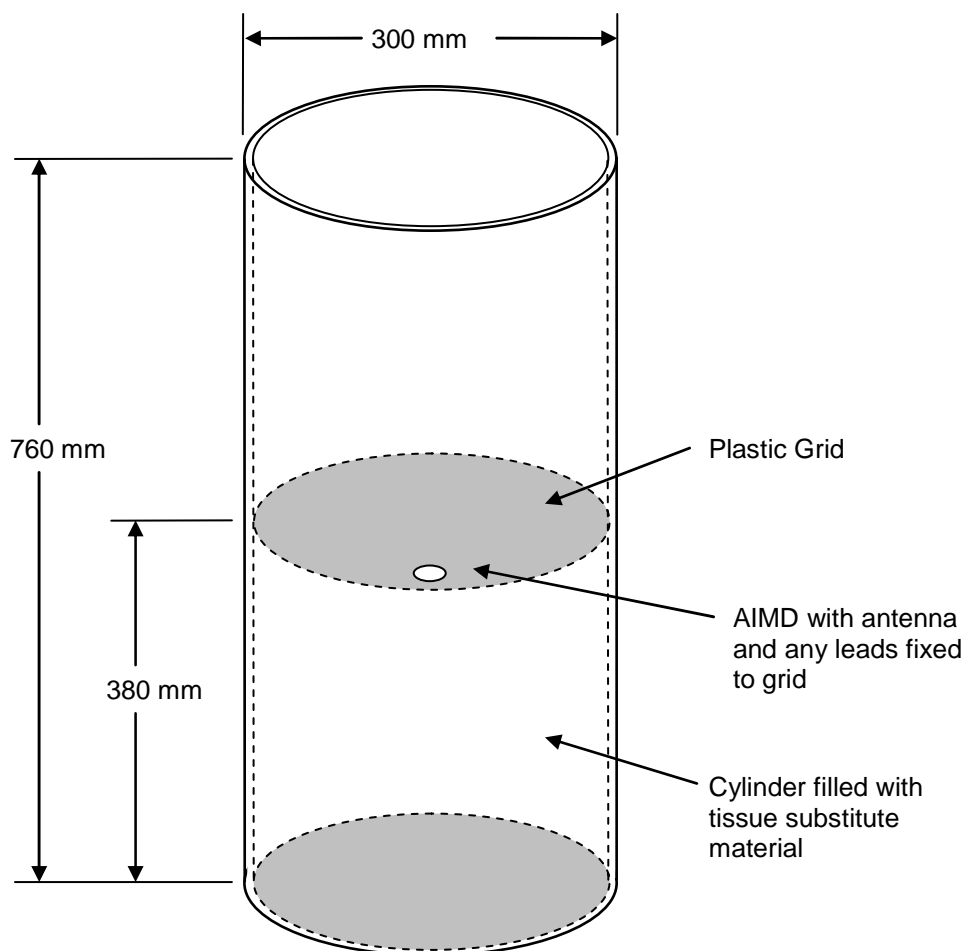

**Figure A.5**

An appropriate simulator for testing ULP-AMI consists of a cylindrical acrylic container with an outside diameter of  $300\text{ mm} \pm 5\text{ mm}$ , a sidewall thickness of  $6\text{ mm} \pm 2,1\text{ mm}$ , and a fluid-filled height of  $760\text{ mm} \pm 5\text{ mm}$ . It shall be filled with a material that is sufficiently fluid that it will flow around the AIMD without any voids. The dielectric and conductivity properties of this material shall match the dielectric and conductivity properties of human muscle tissue at the measurement frequency MHz. Simple saline solutions do not meet the dielectric and conductivity requirements for use as a substitute for human tissue. All emissions measurements will be made using the above specification with the tissue substitute material at a nominal temperature between  $22^{\circ}\text{C}$  and  $38^{\circ}\text{C}$ . This temperature will facilitate testing because it is typical of ambient conditions at many test sites. A mounting grid for the AIMD inside the container shall be provided that permits the radiating element or elements of the AIMD to be positioned vertically and horizontally. The grid should also support any additional AIMD leads associated with the therapeutic function of the AIMD in a fixed repeatable manner such that they do not influence the measurement. The AIMD antenna shall be mounted  $60\text{ mm} \pm 5\text{ mm}$  from the sidewall and centred vertically within the container. When switching from vertical to horizontal positioning, it may be necessary to reposition the antenna to maintain a separation of  $60\text{ mm} \pm 5\text{ mm}$  from the sidewall of the test fixture along its length. AIMD leads will be coiled and placed away from the AIMD antenna while maintaining a nominal 60 mm from the sidewall. The above fixture shall be placed on a turntable such that the AIMD will be located at a nominal 1,5 m height above ground and at a 3 m distance from the measurement antenna. Radiated emissions measurements shall then be performed to insure compliance with the applicable technical specifications.

A formula for a suitable tissue substitute material is defined in the paper "Simulated Biological Materials for Electromagnetic Radiation Absorption Studies" (see bibliography).

## A.1.4 Test antenna

A test antenna is always used in radiated test methods. In emission tests (i.e. frequency error, effective radiated power, spurious emissions and adjacent channel power) the test antenna is used to detect the field from the EUT in one stage of the measurement and from the substitution antenna in the other stage. When the test site is used for the measurement of receiver characteristics (i.e. sensitivity and various immunity parameters) the antenna is used as the transmitting device.

The test antenna should be mounted on a support capable of allowing the antenna to be used in either horizontal or vertical polarization which, on ground plane sites (i.e. anechoic chambers with ground planes and Open Area Test Sites), should additionally allow the height of its centre above the ground to be varied over the specified range (usually 1 metre to 4 metres).

In the frequency band 30 MHz to 1 000 MHz, dipole antennas are generally recommended. For frequencies of 80 MHz and above, the dipoles should have their arm lengths set for resonance at the frequency of test. Below 80 MHz, shortened arm lengths are recommended. For spurious emission testing, however, a combination of bicones and log periodic dipole array antennas (commonly termed "log periodics") could be used to cover the entire 30 MHz to 1 000 MHz band. Above 1 000 MHz, waveguide horns are recommended although, again, log periodics could be used.

NOTE: The gain of a horn antenna is generally expressed relative to an isotropic radiator.

## A.1.5 Substitution antenna

The substitution antenna is used to replace the EUT for tests in which a transmitting parameter (i.e. frequency error, effective radiated power, spurious emissions and adjacent channel power) is being measured. For measurements in the frequency band 30 MHz to 1 000 MHz, the substitution antenna should be a dipole antenna. For frequencies of 80 MHz and above, the dipoles should have their arm lengths set for resonance at the frequency of test. Below 80 MHz, shortened arm lengths are recommended. For measurements above 1 000 MHz, a waveguide horn is recommended. The centre of this antenna should coincide with either the phase centre or volume centre.

## A.1.6 Measuring antenna

The measuring antenna is used in tests on an EUT in which a receiving parameter (i.e. sensitivity and various immunity tests) is being measured. Its purpose is to enable a measurement of the electric field strength in the vicinity of the EUT. For measurements in the frequency band 30 MHz to 1 000 MHz, the measuring antenna should be a dipole antenna. For frequencies of 80 MHz and above, the dipoles should have their arm lengths set for resonance at the frequency of test. Below 80 MHz, shortened arm lengths are recommended. The centre of this antenna should coincide with either the phase centre or volume centre (as specified in the test method) of the EUT.

## A.1.7 Stripline arrangement

### A.1.7.1 General

The stripline arrangement is a RF coupling device for coupling the integral antenna of an equipment to a 50  $\Omega$  radio frequency terminal. This allows the radiated measurements to be performed without an open air test site but in a restricted frequency range. Absolute or relative measurements can be performed; absolute measurements require a calibration of the stripline arrangement.

### A.1.7.2 Description

The stripline is made of three highly conductive sheets forming part of a transmission line which allows the equipment under test to be placed within a known electric field. They shall be sufficiently rigid to support the equipment under test.

### A.1.7.3 Calibration

The aim of calibration is to establish at any frequency a relationship between the voltage applied by the signal generator and the field strength at the designated test area inside the stripline.

#### A.1.7.4 Mode of use

The stripline arrangement may be used for all radiated measurements within its calibrated frequency range.

The method of measurement is the same as the method using an open air test site with the following change. The stripline arrangement input socket is used instead of the test antenna.

---

## A.2 Guidance on the use of radiation test sites

This clause details procedures, test equipment arrangements and verification that should be carried out before any of the radiated test are undertaken. These schemes are common to all types of test sites described in annex A.

### A.2.1 Verification of the test site

No test should be carried out on a test site which does not possess a valid certificate of verification. The verification procedures for the different types of test sites described in annex A (i.e. anechoic chamber, anechoic chamber with a ground plane and Open Area Test Site) are given in the relevant parts of TR 102 273-1-1 [5] or equivalent.

### A.2.2 Preparation of the EUT

The provider should supply information about the EUT covering the operating frequency, polarization, supply voltage(s) and the reference face. Additional information, specific to the type of EUT should include, where relevant, carrier power, channel separation, whether different operating modes are available (e.g. high and low power modes) and if operation is continuous or is subject to a maximum test duty cycle (e.g. 1 minute on, 4 minutes off).

Where necessary, a mounting bracket of minimal size should be available for mounting the EUT on the turntable. This bracket should be made from low conductivity, low relative dielectric constant (i.e. less than 1,5) material(s) such as expanded polystyrene, balsa wood, etc.

### A.2.3 Power supplies to the EUT

All tests should be performed using power supplies wherever possible, including tests on EUT designed for battery-only use. In all cases, power leads should be connected to the EUT's supply terminals (and monitored with a digital voltmeter) but the battery should remain present, electrically isolated from the rest of the equipment, possibly by putting tape over its contacts.

The presence of these power cables can, however, affect the measured performance of the EUT. For this reason, they should be made to be "transparent" as far as the testing is concerned. This can be achieved by routing them away from the EUT and down to the either the screen, ground plane or facility wall (as appropriate) by the shortest possible paths. Precautions should be taken to minimize pick-up on these leads (e.g. the leads could be twisted together, loaded with ferrite beads at 0,15 m spacing or otherwise loaded).

### A.2.4 Volume control setting for analogue speech tests

Unless otherwise stated, in all receiver measurements for analogue speech the receiver volume control where possible, should be adjusted to give at least 50 % of the rated audio output power. In the case of stepped volume controls, to volume control should be set to the first step that provides an output power of at least 50 % of the rated audio output power. This control should not be readjusted between normal and extreme test conditions in tests.



## A.2.5 Range length

The range length for all these types of test facility should be adequate to allow for testing in the far-field of the EUT i.e. it should be equal to or exceed:

$$\frac{2(d_1 + d_2)^2}{\lambda}$$

where:

- $d_1$  is the largest dimension of the EUT/dipole after substitution (m);
- $d_2$  is the largest dimension of the test antenna (m);
- $\lambda$  is the test frequency wavelength (m).

It should be noted that in the substitution part of this measurement, where both test and substitution antennas are half wavelength dipoles, this minimum range length for far-field testing would be:

$$2\lambda$$

It should be noted in the test report when either of these conditions is not met so that the additional measurement uncertainty can be incorporated into the results.

NOTE 1: **For the fully anechoic chamber**, no part of the volume of the EUT should, at any angle of rotation of the turntable, fall outside the "quiet zone" of the chamber at the nominal frequency of the test.

NOTE 2: The "quiet zone" is a volume within the anechoic chamber (without a ground plane) in which a specified performance has either been proven by test, or is guaranteed by the designer/manufacture. The specified performance is usually the reflectivity of the absorbing panels or a directly related parameter (e.g. signal uniformity in amplitude and phase). It should be noted however that the defining levels of the quiet zone tend to vary.

NOTE 3: **For the anechoic chamber with a ground plane**, a full height scanning capability, i.e. 1 to 4 m, should be available for which no part of the test antenna should come within 1 m of the absorbing panels. For both types of Anechoic Chamber, the reflectivity of the absorbing panels should not be worse than -5 dB.

NOTE 4: **For both the anechoic chamber with a ground plane and the Open Area Test Site**, no part of any antenna should come within 0,25 m of the ground plane at any time throughout the tests. Where any of these conditions cannot be met, measurements should not be carried out.

## A.2.6 Site preparation

The cables for both ends of the test site should be routed horizontally away from the testing area for a minimum of 2 m (unless, in the case both types of anechoic chamber, a back wall is reached) and then allowed to drop vertically and out through either the ground plane or screen (as appropriate) to the test equipment. Precautions should be taken to minimize pick up on these leads (e.g. dressing with ferrite beads, or other loading). The cables, their routing and dressing should be identical to the verification set-up.

NOTE: For ground reflection test sites (i.e. anechoic chambers with ground planes and Open Area Test Sites) which incorporate a cable drum with the antenna mast, the 2 m requirement may be impossible to comply with.

Calibration data for all items of test equipment should be available and valid. For test, substitution and measuring antennas, the data should include gain relative to an isotropic radiator (or antenna factor) for the frequency of test. Also, the VSWR of the substitution and measuring antennas should be known.

The calibration data on all cables and attenuators should include insertion loss and VSWR throughout the entire frequency range of the tests. All VSWR and insertion loss figures should be recorded in the log book results sheet for the specific test.

Where correction factors/tables are required, these should be immediately available.

For all items of test equipment, the maximum errors they exhibit should be known along with the distribution of the error e.g.:

- cable loss:  $\pm 0,5$  dB with a rectangular distribution;
- measuring receiver: 1,0 dB (standard deviation) signal level accuracy with a Gaussian error distribution.

At the start of measurements, system checks should be made on the items of test equipment used on the test site.

---

## A.3 Coupling of signals

### A.3.1 General

The presence of leads in the radiated field may cause a disturbance of that field and lead to additional measurement uncertainty. These disturbances can be minimized by using suitable coupling methods, offering signal isolation and minimum field disturbance (e.g. optical and acoustic coupling).

### A.3.2 Data Signals

Isolation can be provided by the use of optical, ultra sonic or infra red means. Field disturbance can be minimized by using a suitable fibre optic connection. Ultra sonic or infra red radiated connections require suitable measures for the minimization of ambient noise.

### A.3.3 Speech and analogue signals

Where an audio output socket is not available an acoustic coupler should be used.

When using the acoustic coupler, care should be exercised that possible ambient noise does not influence the test result.

#### A.3.3.1 Acoustic coupler description

The acoustic coupler comprises a plastic funnel, an acoustic pipe and a microphone with a suitable amplifier. The materials used to fabricate the funnel and pipe should be of low conductivity and of low relative dielectric constant (i.e. less than 1,5).

- The acoustic pipe should be long enough to reach from the EUT to the microphone which should be located in a position that will not disturb the RF field. The acoustic pipe should have an inner diameter of about 6 mm and a wall thickness of about 1,5 mm and should be sufficiently flexible so as not to hinder the rotation of the turntable.
- The plastic funnel should have a diameter appropriate to the size of the loudspeaker in the EUT, with soft foam rubber glued to its edge, it should be fitted to one end of the acoustic pipe and the microphone should be fitted to the other end. It is very important to fix the centre of the funnel in a reproducible position relative to the EUT, since the position of the centre has a strong influence on the frequency response that will be measured. This can be achieved by placing the EUT in a close fitting acoustic mounting jig, supplied by the provider, of which the funnel is an integral part.
- The microphone should have a response characteristic flat within 1 dB over a frequency range of 50 Hz to 20 kHz, a linear dynamic range of at least 50 dB. The sensitivity of the microphone and the receiver audio output level should be suitable to measure a signal to noise ratio of at least 40 dB at the nominal audio output level of the EUT. Its size should be sufficiently small to couple to the acoustic pipe.
- The frequency correcting network should correct the frequency response of the acoustic coupler so that the acoustic SINAD measurement is valid.

### A.3.3.2 Calibration

The aim of the calibration of the acoustic coupler is to determine the acoustic SINAD ratio which is equivalent to the SINAD ratio at the receiver output.

---

## A.4 Standard test position

The standard position in all test sites, except the stripline arrangement, for equipment which is not intended to be worn on a person, including hand-held equipment, shall be on a non conducting support, height 1,5 m, capable of rotating about a vertical axis through the equipment. The standard position of the equipment shall be the following:

- a) for equipment with an internal antenna, it shall be placed in the position closest to normal use as declared by the provider;
- b) for equipment with a rigid external antenna, the antenna shall be vertical;
- c) for equipment with a non-rigid external antenna, the antenna shall be extended vertically upwards by a non-conducting support.

Equipment which is intended to be worn on a person may be tested using a simulated man as support.

The simulated man comprises a rotatable acrylic tube filled with salt water, placed on the ground.

The container shall have the following dimensions:

- Height:  $1,7 \pm 0,1$  m;
- Inside diameter:  $300 \pm 5$  mm;
- Sidewall thickness:  $5 \pm 0,5$  mm.

The container shall be filled with a salt (NaCl) solution of 1,5 g per litre of distilled water.

The equipment shall be fixed to the surface of the simulated man, at the appropriate height for the equipment.

NOTE: To reduce the weight of the simulated man it may be possible to use an alternative tube which has a hollow centre of 220 mm maximum diameter.

In the stripline arrangement the equipment under test or the substitution antenna is placed in the designated test area in the normal operational position, relative to the applied field, on a pedestal made of a low dielectric material (dielectric constant less than 2).

---

## A.5 Test fixture

The test fixture is only needed for the assessment of integral antenna equipment

### A.5.1 Description

The test fixture is a radio frequency coupling device associated with an integral antenna equipment for coupling the integral antenna to a  $50 \Omega$  radio frequency terminal at the working frequencies of the equipment under test. This allows certain measurements to be performed using the conducted measurement methods. Only relative measurements may be performed and only those at or near frequencies for which the test fixture has been calibrated.

In addition, the test fixture may provide:

- a) a connection to an external power supply;
- b) in the case of assessment of speech equipment, an audio interface either by direct connection or by an acoustic coupler.

In the case of non-speech equipment, the test fixture can also provide the suitable coupling means e.g. for the data output.

The test fixture shall normally be provided by the provider.

The performance characteristics of the test fixture shall be approved by the testing laboratory and shall conform to the following basic parameters:

- a) the coupling loss shall not be greater than 30 dB;
- b) a coupling loss variation over the frequency range used in the measurement which does not exceed 2 dB;
- c) circuitry associated with the RF coupling shall contain no active or non-linear devices;
- d) the VSWR at the 50  $\Omega$  socket shall not be more than 1,5 over the frequency range of the measurements;
- e) the coupling loss shall be independent of the position of the test fixture and be unaffected by the proximity of surrounding objects or people. The coupling loss shall be reproducible when the equipment under test is removed and replaced;
- f) the coupling loss shall remain substantially constant when the environmental conditions are varied.

The characteristics and calibration shall be included in the test report.

## A.5.2 Calibration

The calibration of the test fixture establishes a relationship between the output of the signal generator and the field strength applied to the equipment placed in the test fixture.

The calibration is valid only at a given frequency and for a given polarization of the reference field.

The actual set-up used depends on the type of the equipment (e.g. data, speech etc.).

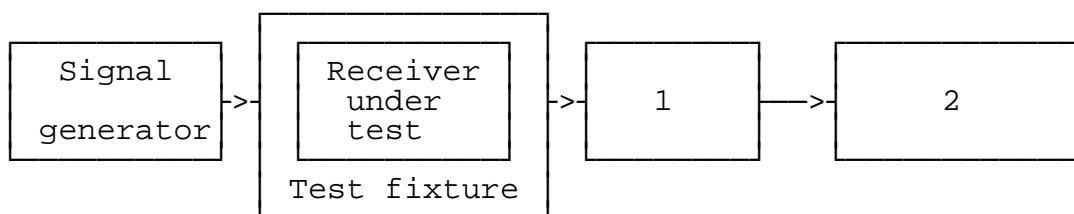

- 1) Coupling device, e.g. AF load/acoustic coupler (in the case of speech equipment).
- 2) Device for assessing the performance, e.g. distortion factor/audio level meter, BER measuring device etc.

**Figure A.6: Measuring arrangement for calibration**

Method of calibration:

- a) Measure the sensitivity expressed as a field strength, as specified in the present document and note the value of this field strength in dB $\mu$ V/m and the polarization used.
- b) Place the receiver in the test fixture which is connected to the signal generator. The level of the signal generator producing:
  - a SINAD of 20 dB;
  - a bit error ratio of 0,01; or
  - a message acceptance ratio of 80 %, as appropriate
 shall be noted.

The calibration of the test fixture is the relationship between the field strength in dB $\mu$ V/m and the signal generator level in dB $\mu$ V emf. This relationship is expected to be linear.

### A.5.3 Mode of use

The test fixture may be used to facilitate some of the measurements in the case of equipment having an integral antenna.

It is used in particular for the measurement of the radiated carrier power and usable sensitivity expressed as a field strength under the extreme conditions.

For the transmitter measurements calibration is not required as relative measuring methods are used.

For the receiver measurements calibration is necessary as absolute measurements are used.

To apply the specified wanted signal level expressed in field strength, convert it into the signal generator level (emf) using the calibration of the test fixture. Apply this value to the signal generator.

## Annex B (normative): Specification for measurement filter

Methods of measurement in clause 8.4 refer to the use of a filter. The IF filter shall be within the limits of the selectivity characteristic of figure B.1.

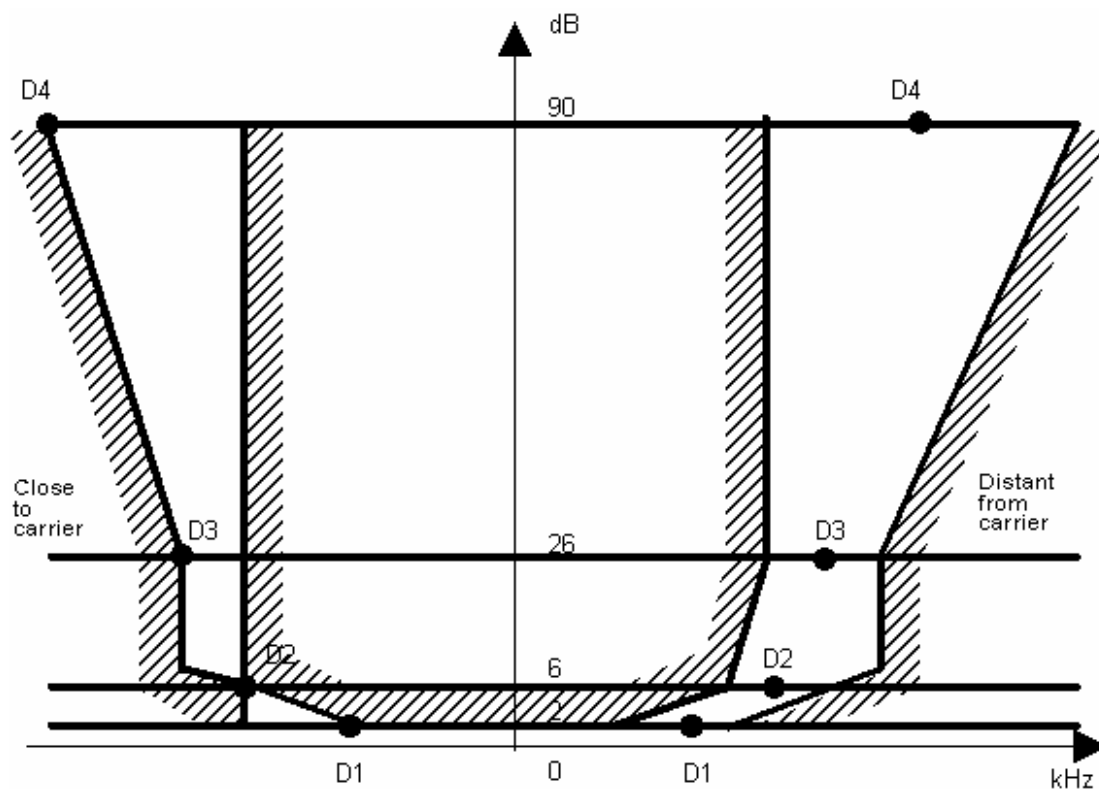

Figure B.1: IF filter

The selectivity characteristic shall keep the frequency separations from the nominal centre frequency of the adjacent channel as stated in table B.1.

Table B.1: Selectivity characteristic

| Frequency separation of filter curve from nominal centre frequency of adjacent channel (kHz) |      |     |     |
|--|------|-----|-----|
| D1   | D2   | D3  | D4  |
| 3  | 4,25 | 5,5 | 9,5 |

The attenuation points shall not exceed the tolerances as stated in tables B.2 and B.3.

Table B.2: Attenuation points close to carrier

| Tolerances range (kHz) |       |       |       |
|------------------------|-------|-------|-------|
| D1                     | D2    | D3    | D4    |
| +1,35                  | ± 0,1 | -1,35 | -5,35 |

**Table B.3: Attenuation points distant from the carrier**

| Tolerance range (kHz) |           |           |              |
|-----------------------|-----------|-----------|--------------|
| D1                    | D2        | D3        | D4           |
| $\pm 2,0$             | $\pm 2,0$ | $\pm 2,0$ | +2,0<br>-6,0 |

The minimum attenuation of the filter, outside the 90 dB attenuation points, shall greater than or equal to 90 dB.

---

## Annex C (normative): Technical performance of the spectrum analyser

Methods of measurement in clause 8.5 refer to the use of a spectrum analyser. The characteristics of the spectrum analyser shall meet at least the following requirements:

- the reading accuracy of the frequency marker shall be within  $\pm 100$  Hz;
- the accuracy of relative amplitude measurements shall be within  $\pm 3,5$  dB.

It shall be possible to adjust the spectrum analyser to allow the separation on its screen of two equal amplitude components with a frequency difference of 100 Hz.

For statistically distributed modulations, the spectrum analyser and the integrating device (when appropriate) needs to allow determination of the power spectral density (energy per time and bandwidth), which has to be integrated over the bandwidth in question.

The spectrum analyser should have a dynamic range greater than 80 dB and the average phase noise in the adjacent and alternate channels shall be such that measurement of adjacent and alternate channel power (see clause 8.5) is not limited by phase noise. In order to confirm this the selected measurement technique for clause 8.5.2 shall be used to measure the adjacent and alternate channel power with a unmodulated signal source with phase noise of less than -110 dBc/Hz at one channel spacing offset and -120 dBc/Hz at two channel spacing offset. The maximum adjacent channel power observed with these conditions shall not exceed -60 dBc, and the maximum alternate channel power measured with these conditions shall not exceed -70 dBc.



---

## Annex D (informative): Bibliography

ERC Report 44 (1997): "Sharing between inductive systems and radiocommunications systems in the band 9 kHz to 135 kHz".

ETSI EN 301 489-3 (V1.2.1): "Electromagnetic compatibility and Radio spectrum Matters (ERM); ElectroMagnetic Compatibility (EMC) standard for radio equipment and services; Part 3: Specific conditions for Short-Range Devices (SRD) operating on frequencies between 9 kHz and 40 GHz".

Directive 98/34/EC of the European Parliament and of the Council of 22 June 1998 laying down a procedure for the provision of information in the field of technical standards and regulations.

ETSI EN 300 330-1 (V1.3.1): "Electromagnetic compatibility and Radio Spectrum Matters (ERM); Short Range Devices; Radio equipment in the frequency range 9 kHz to 25 MHz and inductive loop systems in the frequency range 9 kHz to 30 MHz Part 1: Technical characteristics and test methods".

Ketterling, H-P: "Verification of the performance of fully and semi-anechoic chambers for radiation measurements and susceptibility/immunity testing", 1991, Leatherhead/Surrey.

Directive 1999/5/EC of the European Parliament and of the Council of 9 March 1999 on radio equipment and telecommunications terminal equipment and the mutual recognition of their conformity (R&TTE Directive).

CISPR 16-2-3 (2003): "Specification for radio disturbance and immunity measuring apparatus and methods. Part 2-3: Methods of measurement of disturbances and immunity - Radiated disturbance measurements".

ETSI EN 302 510-2 (V1.1.1): "Electromagnetic compatibility and Radio spectrum Matters (ERM); Radio equipment in the frequency range 30 MHz to 37,5 MHz for Ultra Low Power Active Medical Membrane Implants and Accessories; Part 2: Harmonized EN covering essential requirements of article 3.2 of the R&TTE Directive".

Council Directive 90/385/EEC of 20 June 1990 on the approximation of the laws of the Member States relating to active implantable medical devices (AMD Directive).

Gabriel, C.: "Compilation of the Dielectric Properties of Body Tissues at RF and Microwave Frequencies", Brooks Air Force Technical Report AL/OE-TR-1996-0037, 1996.

---

## History

| <b>Document history</b> |          |                |                                       |
|-------------------------|----------|----------------|---------------------------------------|
| V1.1.1                  | May 2006 | Public Enquiry | PE 20060929: 2006-05-31 to 2006-09-29 |
|                         |          |                |                                       |
|                         |          |                |                                       |
|                         |          |                |                                       |
|                         |          |                |                                       |