

ETSI EN 302 500-1 V2.1.1 (2010-10)

European Standard (Telecommunications series)

**Electromagnetic compatibility
and Radio spectrum Matters (ERM);
Short Range Devices (SRD) using
Ultra WideBand (UWB) technology;
Location Tracking equipment operating in
the frequency range from 6 GHz to 9 GHz;
Part 1: Technical characteristics and
methods of measurement**



ReferenceREN/ERM-TGUWB-009-1

Keywordsradio, regulation, SRD, testing, UWB

ETSI

650 Route des Lucioles
F-06921 Sophia Antipolis Cedex - FRANCE

Tel.: +33 4 92 94 42 00 Fax: +33 4 93 65 47 16

Siret N° 348 623 562 00017 - NAF 742 C
Association à but non lucratif enregistrée à la
Sous-Préfecture de Grasse (06) N° 7803/88

Important notice

Individual copies of the present document can be downloaded from:

<http://www.etsi.org>

The present document may be made available in more than one electronic version or in print. In any case of existing or perceived difference in contents between such versions, the reference version is the Portable Document Format (PDF). In case of dispute, the reference shall be the printing on ETSI printers of the PDF version kept on a specific network drive within ETSI Secretariat.

Users of the present document should be aware that the document may be subject to revision or change of status. Information on the current status of this and other ETSI documents is available at

<http://portal.etsi.org/tb/status/status.asp>

If you find errors in the present document, please send your comment to one of the following services:

http://portal.etsi.org/chaicor/ETSI_support.asp

Copyright Notification

No part may be reproduced except as authorized by written permission.
The copyright and the foregoing restriction extend to reproduction in all media.

© European Telecommunications Standards Institute 2010.
All rights reserved.

DECT™, **PLUGTESTS™**, **UMTS™**, **TIPHON™**, the TIPHON logo and the ETSI logo are Trade Marks of ETSI registered for the benefit of its Members.

3GPP™ is a Trade Mark of ETSI registered for the benefit of its Members and of the 3GPP Organizational Partners.

LTE™ is a Trade Mark of ETSI currently being registered

for the benefit of its Members and of the 3GPP Organizational Partners.

GSM® and the GSM logo are Trade Marks registered and owned by the GSM Association.

Contents

Intellectual Property Rights	5
Foreword.....	5
1 Scope	7
2 References	7
2.1 Normative references	7
2.2 Informative references.....	7
3 Definitions, symbols and abbreviations	8
3.1 Definitions.....	8
3.2 Symbols.....	9
3.3 Abbreviations	9
4 Technical requirement specifications	9
4.1 General requirements	9
4.2 Presentation of equipment for testing purposes.....	9
4.2.1 Choice of model for testing	10
4.2.1.1 Auxiliary test equipment	10
4.2.1.2 Declarations by the provider	10
4.3 Mechanical and electrical design.....	10
4.3.1 General.....	10
4.3.2 Controls	10
4.3.3 Transmitter shut-off facility.....	10
4.3.4 Marking	10
4.3.4.1 Equipment identification.....	11
4.3.4.2 Additional information for the user.....	11
4.4 Other device emissions.....	11
5 Test conditions, power sources and ambient temperatures	11
5.1 Normal and extreme test conditions	11
5.2 Power sources.....	11
5.2.1 Power sources for stand-alone equipment	11
5.2.2 Power sources for plug-in radio devices	12
5.3 Normal test conditions.....	12
5.3.1 Normal temperature and humidity.....	12
5.3.2 Normal test power source	12
5.3.2.1 Mains voltage.....	12
5.3.2.2 Regulated lead-acid battery power sources	12
5.3.2.3 Other power sources.....	12
6 General conditions.....	12
6.1 Modes of operation of the transmitter	12
6.2 Normal test signals	13
6.3 Test sites and general arrangements for radiated measurements	13
6.4 Testing of host connected equipment and plug-in radio devices.....	13
6.4.1 The use of a host or test fixture for testing plug-in radio devices.....	14
6.4.2 Testing of combinations.....	14
6.4.2.1 Alternative A: General approach for combinations.....	14
6.4.2.2 Alternative B: For host equipment with a plug-in radio device	14
6.4.2.3 Alternative C: For combined equipment with a plug-in radio device	14
7 Interpretation of results	14
7.1 Measurement uncertainty	14
7.1.1 Measurement uncertainty is equal to or less than maximum acceptable uncertainty.....	15
7.1.2 Measurement uncertainty is greater than maximum acceptable uncertainty.....	15
7.2 Other emissions	16
8 Methods of measurement and limits for transmitter parameters	16

8.1	Maximum mean e.i.r.p. spectral density.....	16
8.1.1	Definition.....	16
8.1.2	Methods of measurement.....	16
8.1.3	Limits.....	17
8.2	Frequency of highest maximum mean e.i.r.p. spectral density.....	17
8.2.1	Definition.....	17
8.2.2	Methods of measurement.....	17
8.2.3	Limits.....	17
8.3	Maximum peak e.i.r.p.....	17
8.3.1	Definition.....	17
8.3.2	Methods of measurement.....	18
8.3.3	Limits.....	18
8.4	Indirect Detect-And-Avoid (DAA)	19
8.4.1	Introduction.....	19
8.4.2	Design requirement.....	19
8.4.3	Method of measurement	19
8.4.4	Limits.....	19
9	Methods of measurement and limits for receiver parameters.....	20
9.1	Receiver spurious emissions.....	20
9.1.1	Definition.....	20
9.1.2	Test procedure	20
9.1.3	Limit	21
Annex A (normative): Radiated measurement.....		22
A.1	Test sites and general arrangements for measurements involving the use of radiated fields.....	22
A.1.1	Anechoic chamber.....	22
A.1.2	Anechoic chamber with a conductive ground plane.....	23
A.1.3	Outdoor test site	25
A.1.4	Test antenna.....	26
A.1.5	Substitution antenna	26
A.2	Guidance on the use of radiation test sites	26
A.2.1	Verification of the test site	26
A.2.2	Preparation of the EUT.....	26
A.2.3	Power supplies to the EUT.....	27
A.2.4	Range length.....	27
A.2.5	Site preparation	28
A.2.6	General requirements for RF cables	28
A.3	Coupling of signals.....	28
A.3.1	General	28
A.3.2	Data Signals.....	28
A.4	Standard test position	29
A.5	Standard test methods.....	29
A.5.1	Calibrated setup.....	29
A.5.2	Substitution method.....	30
A.5.3	Conducted method.....	31
A.6	Standard calibration method.....	31
Annex B (normative): Technical performance of the spectrum analyser.....		33
Annex C (informative): Measurement antenna and preamplifier specifications		34
Annex D (informative): Calculation of peak limit for 3 MHz measurement bandwidth.....		35
Annex E (informative): Bibliography.....		37
History		38

Intellectual Property Rights

IPRs essential or potentially essential to the present document may have been declared to ETSI. The information pertaining to these essential IPRs, if any, is publicly available for **ETSI members and non-members**, and can be found in ETSI SR 000 314: "*Intellectual Property Rights (IPRs); Essential, or potentially Essential, IPRs notified to ETSI in respect of ETSI standards*", which is available from the ETSI Secretariat. Latest updates are available on the ETSI Web server (<http://webapp.etsi.org/IPR/home.asp>).

Pursuant to the ETSI IPR Policy, no investigation, including IPR searches, has been carried out by ETSI. No guarantee can be given as to the existence of other IPRs not referenced in ETSI SR 000 314 (or the updates on the ETSI Web server) which are, or may be, or may become, essential to the present document.

Foreword

This European Standard (Telecommunications series) has been produced by ETSI Technical Committee Electromagnetic compatibility and Radio spectrum Matters (ERM).

For non EU countries the present document may be used for regulatory (Type Approval) purposes.

The present document is part 1 of a multi-part deliverable covering Short Range Devices (SRD) using Ultra WideBand (UWB) technology; Location Tracking equipment operating in the frequency range from 6 GHz to 9 GHz, as identified below:

Part 1: "Technical characteristics and methods of measurement";

Part 2: "Harmonized EN covering the essential requirements of article 3.2 of the R&TTE Directive".

Clauses 1 and 3 provide a general description on the types of equipment covered by the present document and the definitions and abbreviations used.

Clause 4 provides a guide as to the number of samples required in order that type tests may be carried out, and any markings on the equipment which the provider shall provide.

Clauses 5 and 6 give guidance on the test and general conditions for testing of the device.

Clause 7 gives the interpretation of results and maximum measurement uncertainty values.

Clause 8 specifies the transmitter spectrum utilization parameters which are required to be measured. The clauses provide details on how the equipment should be tested and the conditions which should be applied.

Clause 9 specifies the receiver spectrum utilization parameters which are required to be measured. The clauses provide details on how the equipment should be tested and the conditions which should be applied.

Annex A (normative) provides specifications concerning radiated measurements.

Annex B (normative) provides information on the spectrum analyser specification.

Annex C (informative) provides information on measurement antenna and preamplifier specifications.

Annex D (informative) provides information on peak measurements within a 3 MHz measurement bandwidth.

Annex E (informative) covers other supplementary information.

National transposition dates

Date of adoption of this EN:	5 October 2010
Date of latest announcement of this EN (doa):	31 January 2011
Date of latest publication of new National Standard or endorsement of this EN (dop/e):	31 July 2011
Date of withdrawal of any conflicting National Standard (dow):	31 July 2011

1 Scope

The present document specifies the requirements for Ultra Wideband location tracking equipment operating in all or part of the frequency range from 6 GHz to 9 GHz.

The present document applies for indoor as well as portable or mobile outdoor applications.

It covers Ultra Wideband location tracking tags which are attached to people or objects and tags are tracked using a fixed receiver infrastructure to only receive the UWB emission emitted by the tags. Equipment covered by the present document is fitted with an integral or dedicated antenna.

Transmitter equipment covered by the present document does not have a direct Detect-And-Avoid capability (see [4] and [5]).

The present document contains the technical characteristics and test methods for location tracking equipment and it does not necessarily include all the characteristics which may be required by a user, nor does it necessarily represent the optimum performance achievable.

2 References

References are either specific (identified by date of publication and/or edition number or version number) or non-specific. For specific references, only the cited version applies. For non-specific references, the latest version of the reference document (including any amendments) applies.

Referenced documents which are not found to be publicly available in the expected location might be found at <http://docbox.etsi.org/Reference>.

NOTE: While any hyperlinks included in this clause were valid at the time of publication ETSI cannot guarantee their long term validity.

2.1 Normative references

The following referenced documents are necessary for the application of the present document.

- [1] ETSI TR 100 028 (V1.4.1) (all parts): "Electromagnetic compatibility and Radio spectrum Matters (ERM); Uncertainties in the measurement of mobile radio equipment characteristics".
- [2] CISPR 16-1-1 (2010): "Specification for radio disturbance and immunity measuring apparatus and methods - Part 1-1: Radio disturbance and immunity measuring apparatus - Measuring apparatus".
- [3] ANSI C63.5 (2006): "American National Standard for Calibration of Antennas Used for Radiated Emission Measurements in Electro Magnetic Interference".
- [4] ETSI TS 102 754 (V1.2.1): "Electromagnetic compatibility and Radio spectrum matters (ERM); Short Range Devices (SRD); Technical characteristics of Detect-and-Avoid (DAA) mitigation techniques for SRD equipment using Ultra Wideband (UWB) technology".
- [5] ETSI EN 302 065 (V1.2.1): "Electromagnetic compatibility and Radio spectrum Matters (ERM); Short Range Devices (SRD) using Ultra Wide Band technology (UWB) for communications purposes; Harmonized EN covering the essential requirements of article 3.2 of the R&TTE Directive".

2.2 Informative references

The following referenced documents are not necessary for the application of the present document but they assist the user with regard to a particular subject area.

- [i.1] ITU-R Recommendation SM.1754: "Measurement techniques of ultra-wideband transmissions".

- [i.2] ETSI TR 102 070-2 (V1.1.1): "Electromagnetic compatibility and Radio spectrum Matters (ERM); Guide to the application of harmonized standards to multi-radio and combined radio and non-radio equipment; Part 2: Effective use of the radio frequency spectrum".
- [i.3] ETSI TR 102 273 (V1.2.1) (all parts): "Electromagnetic compatibility and Radio spectrum Matters (ERM); Improvement on Radiated Methods of Measurement (using test site) and evaluation of the corresponding measurement uncertainties".

3 Definitions, symbols and abbreviations

3.1 Definitions

For the purposes of the present document, the following terms and definitions apply:

combined equipment: any combination of non-radio equipment and a plug-in radio device that would not offer full functionality without the radio device

dedicated antenna: removable antenna supplied and tested with the radio equipment, designed as an indispensable part of the equipment

effective radiated power (e.r.p.): product of the power supplied to the antenna and its gain relative to a half-wave dipole in a given direction (RR 1.162)

equivalent isotropically radiated power (e.i.r.p.): product of the power supplied to the antenna and the antenna gain in a given direction relative to an isotropic antenna (absolute or isotropic gain) (RR 1.161)

fixed-mounted station: station which is fixed mounted and which is not intended to be operated while in motion; however, it behaves otherwise in the system like a mobile station

host: host equipment is any equipment which has complete user functionality when not connected to the radio equipment part and to which the radio equipment part provides additional functionality and to which connection is necessary for the radio equipment part to offer functionality

impulsive UWB signal: radiated, short transient Ultra Wideband signal whose occupied bandwidth is defined by its time duration rather than by frequency-hopping or other techniques

integral antenna: antenna designed to be connected to the equipment without the use of a standard connector and considered to be part of the equipment

NOTE: An integral antenna may be fitted internally or externally to the equipment.

Mobile Station (MS): station intended to be used while in motion or during halts at unspecified points

Non-Interference Mode operation (NIM): operational mode that allows the use of the radio spectrum on a non-interference basis without active mitigation techniques

plug-in radio device: radio equipment module intended to be used with or within host, combined or multi-radio equipment, using their control functions and power supply

portable station: mobile station that is portable but cannot comfortably be carried around by a person due to weight and/or size or having relatively high power consumption

provider: manufacturer or his authorized representative or the person responsible for placing on the market

pulse: radiated short transient UWB signal whose time duration is nominally the reciprocal of its -10 dB bandwidth

NOTE: See ITU-R Recommendation SM.1754 [i.1].

radiated measurements: measurements which involve the absolute measurement of a radiated field

stand-alone radio equipment: equipment that is intended primarily as location tracking equipment and that is normally used on a stand-alone basis

Ultra WideBand (UWB): equipment incorporating, as an integral part or as an accessory, technology for short-range radiocommunication, involving the intentional generation and transmission of radio-frequency energy that spreads over a frequency range wider than 50 MHz, which may overlap several frequency bands allocated to radiocommunication services

3.2 Symbols

For the purposes of the present document, the following symbols apply:

dB	decibel
R	distance
λ	wavelength

3.3 Abbreviations

For the purposes of the present document, the following abbreviations apply:

DAA	Detect And Avoid
e.i.r.p.	equivalent isotropically radiated power
e.r.p.	effective radiated power
EMC	ElectroMagnetic Compatibility
EUT	Equipment Under Test
LNA	Low Noise Amplifier
MS	Mobile Station
NIM	Non-Interference Mode
PRF	Pulse Repetition Frequency
R&TTE	Radio and Telecommunications Terminal Equipment
RBW	Resolution BandWidth
RF	Radio Frequency
rms	root mean square
SNR	Signal to Noise Ratio
SRD	Short Range Device
TX	Transmitter
UWB	Ultra WideBand
VBW	Video BandWidth
VSWR	Voltage Standing Wave Ratio

4 Technical requirement specifications

4.1 General requirements

Equipment supplied for testing against the present document shall be fitted with either an integral antenna or a dedicated antenna.

4.2 Presentation of equipment for testing purposes

Each equipment submitted for testing shall fulfil the requirements of the present document on all frequencies over which it is intended to operate.

To simplify and harmonize the testing procedures between the different testing laboratories, measurements shall be performed, according to the present document, on samples of equipment defined in clause 4.2.1.

These clauses are intended to give confidence that the requirements set out in the present document have been met without the necessity of performing measurements on all frequencies.

4.2.1 Choice of model for testing

The provider shall provide one or more samples of the equipment, as appropriate, for testing.

If an equipment has several optional features, considered not to affect the RF parameters then tests need only be performed on the equipment configured with that combination of features considered to be the most complex, as proposed by the provider and agreed by the test laboratory.

For equipment which can be presented for testing with a 50 Ohm antenna connector, conducted transmitter measurements can be made providing suitable antenna calibrations data are available. See clause A.5.3.

4.2.1.1 Auxiliary test equipment

All necessary test signal sources, setting up instructions and other product information shall accompany the equipment when it is submitted for testing.

4.2.1.2 Declarations by the provider

The provider shall declare the necessary information regarding the equipment with respect to all technical requirements set by the present document, including:

- the operating frequency of the equipment (see clause 8.2.1);
- the type of the equipment (e.g. stand-alone equipment, plug-in radio device, combined equipment, etc.), (see also clause 6.4);
- the intended combination(s) of the radio equipment power settings and one or more antenna assemblies and their corresponding e.i.r.p. levels:
 - the nominal power supply voltages of the stand-alone radio equipment or the nominal power supply voltages of the host equipment or combined equipment in case of plug-in devices;
 - the test modulation to be used for testing (see also clause 6.1);
 - the implementation of any mitigation techniques.

4.3 Mechanical and electrical design

4.3.1 General

The equipment submitted by the provider or his representative, shall be designed, constructed and manufactured in accordance with good engineering practice, and with the aim of minimizing harmful interference to other equipment and services.

4.3.2 Controls

Those controls, which, if maladjusted, may increase the interfering potential of the equipment, shall not be easily accessible to the user.

4.3.3 Transmitter shut-off facility

If the equipment is equipped with an automatic transmitter shut-off facility, it shall be possible to disable this feature for the purposes of testing. See clause 8.

4.3.4 Marking

The equipment shall be marked in a visible place. This marking shall be legible and durable. In cases where the equipment is too small to carry the marking, it is sufficient to provide the relevant information in the users' manual.

4.3.4.1 Equipment identification

The marking shall include as a minimum:

- The name of the manufacturer or his trademark.
- The type designation. This is the manufacturer's numeric or alphanumeric code or name that is specific to a particular equipment.

4.3.4.2 Additional information for the user

The following additional information shall be included in the users' manual:

- statements that a UWB transmitter conforming to the present document shall not be:
 - installed at a fixed outdoor location;
 - installed or used in flying models, aircraft and other forms of aviation;
 - operated on board a road or rail vehicle running on a public network or highway.

4.4 Other device emissions

The equipment may contain digital circuit elements, radio circuit elements and other elements whose performance is not covered by the present document. These elements of the equipment shall meet the appropriate performance requirements for those components, as specified in other standards.

NOTE: For further information on this topic see TR 102 070-2 [i.2].

5 Test conditions, power sources and ambient temperatures

5.1 Normal and extreme test conditions

Testing shall be performed under normal test conditions.

The test conditions and procedures shall be as specified in clauses 5.2 and 5.3.

5.2 Power sources

5.2.1 Power sources for stand-alone equipment

For non-battery-operated equipment, during testing the power source of the equipment shall be replaced by an external test power source capable of producing normal test voltages as specified in clause 5.3.2. The internal impedance of the test power source shall be low enough for its effect on the test results to be negligible. For the purpose of tests, the voltage of the power source shall be measured at the input terminals of the equipment. During tests the power source voltages shall be maintained within a tolerance of ± 1 % relative to the voltage at the beginning of each test.

For battery-operated equipment, fully-charged internal batteries shall be used. The batteries used shall be as supplied or recommended by the provider. If internal batteries are used, at the end of each test the voltage shall be within a tolerance of ± 5 % relative to the voltage at the beginning of each test. If the battery is not accessible (for example, it is internal to a sealed unit), then it is acceptable to determine the battery voltage at the start and end of the test by indirect means (e.g. battery health messages sent from the unit itself).

Alternatively, for battery-operated equipment, the external test power source may replace the supplied or recommended internal batteries at the required voltage - this shall be recorded and stated. In this case, the battery remains present, electrically isolated from the rest of the equipment, possibly by putting tape over its contacts.

5.2.2 Power sources for plug-in radio devices

The power source for testing plug-in radio devices shall be provided by a test fixture or host equipment.

Where the host equipment and/or the plug-in radio device is battery powered, the battery may be removed and the test power source applied as close to the battery terminals as practicable.

5.3 Normal test conditions

5.3.1 Normal temperature and humidity

The normal temperature and humidity conditions for tests shall be any convenient combination of temperature and humidity within the following ranges:

- temperature: +15 °C to +35 °C;
- relative humidity: 20 % to 75 %.

When it is impracticable to carry out tests under these conditions, a note to this effect stating the ambient temperature and relative humidity during the tests, shall be recorded and stated.

5.3.2 Normal test power source

5.3.2.1 Mains voltage

The normal test voltage for equipment to be connected to the mains shall be the nominal mains voltage. For the purpose of the present document, the nominal voltage shall be the declared voltage, or any of the declared voltages, for which the equipment was designed.

The frequency of the test power source corresponding to the ac mains shall be between 49 Hz and 51 Hz.

5.3.2.2 Regulated lead-acid battery power sources

When the radio equipment is intended for operation from the usual types of regulated lead-acid battery power source the normal test voltage shall be 1,1 multiplied by the nominal voltage of the battery (6 V, 12 V, etc.).

5.3.2.3 Other power sources

For operation from other power sources or types of battery (primary or secondary), the normal test voltage shall be that declared by the equipment provider. Such values shall be recorded and stated.

6 General conditions

6.1 Modes of operation of the transmitter

For the purpose of the measurements according to the present document, the transmitter shall be operated at the highest data rate which would be available in an operating mode. For packet based systems, this would include both the highest pulse repetition rate as well as the highest packet rate.

Where the transmitter is designed with an adjustable output power, then all transmitter parameters shall be measured using the highest power level, as declared by the provider.

If the transmitter is equipped with an automatic transmitter shut-off facility, it shall be made inoperative for the duration of the test.

The manufacturer shall declare that the operating mode used during testing meets the above requirements.

NOTE: Care should be taken when performing measurements on non-continuous transmitters, particularly those with low duty cycle, to ensure that the measurement equipment has captured the highest emissions from the device as it is rotated.

6.2 Normal test signals

The test data that is used to modulate the transmitted signal for measurement of UWB emissions shall be similar to the data transmitted in the actual operation of the equipment. The test data shall be chosen so as to produce the highest mean transmit power spectral density which would be available in operation.

The manufacturer shall declare that the transmitted signal used during testing meets the above requirements.

The provider shall state as part of the test report the UWB modulation characteristics of the equipment under test, to the full extent necessary.

6.3 Test sites and general arrangements for radiated measurements

The test site used for radiated transmitter measurements shall be as described in clauses A.1.1 or A.1.2 (i.e. only the "anechoic chamber" or "anechoic chamber with ground plane" test sites).

The test site used for radiated receiver measurements shall be as described in clauses A.1.1, A.1.2 or A.1.3.

The substitution antenna used for radiated measurements shall be as described in clause A.1.4.

The substitution antenna used for radiated measurements shall be as described in clause A.1.5.

For guidance on use of radiation test sites, coupling of signals and standard test positions used for radiated measurements, see clauses A.2 to A.4.

Detailed descriptions of radiated measurement arrangements for UWB devices can be found in ITU-R Recommendation SM.1754 [i.1].

All reasonable efforts should be made to clearly demonstrate that emissions from the UWB transmitter do not exceed the specified levels, with the transmitter in the far field. To the extent practicable, the device under test should be measured at the distance specified in clause A.2.4 and with the specified measurement bandwidths (see clause 8). However, in order to obtain an adequate signal-to-noise ratio in the measurement system, radiated measurements may have to be made at distances less than those specified in clause A.2.4 and/or with reduced measurement bandwidths. The revised measurement configuration shall be stated on the test report, together with an explanation of why the signal levels involved necessitated measurement at the distance employed or with the measurement bandwidth used in order to be accurately detected by the measurement equipment and calculations demonstrating compliance.

Where it is not practical to further reduce the measurement bandwidth (either because of limitations of commonly-available test equipment or difficulties in converting readings taken using one measurement bandwidth to those used by the limits in tables 2 to 4, and the required measurement distance would be so short that the device would not clearly be within the far field, the test report shall state this fact, the measurement distance and bandwidth used, the near field/far field distance for the measurement setup (see clause A.2.4), the measured device emissions, the achievable measurement noise floor and the frequency range(s) involved.

6.4 Testing of host connected equipment and plug-in radio devices

For combined equipment and for radio parts for which connection to or integration with host equipment is required to offer functionality to the radio, different alternative test approaches are permitted. Where more than one such combination is intended, testing shall not be repeated for combinations of the radio part and various host equipment where the latter are substantially similar.

Where more than one such combination is intended and the combinations are substantially dissimilar, one combination shall be tested against all requirements of the present document and all other combinations shall be tested separately for radiated spurious emissions only.

6.4.1 The use of a host or test fixture for testing plug-in radio devices

Where the radio part is a plug-in radio device which is intended to be used within a variety of combinations, a suitable test configuration consisting of either a test fixture or a typical host equipment shall be used. This shall be representative for the range of combinations in which the device may be used. The test fixture shall allow the radio equipment part to be powered and stimulated as if connected to or inserted into the host or combined equipment. Measurements shall be made to all requirements of the present document.

NOTE: For further information on this topic, see TR 102 070-2 [i.2].

6.4.2 Testing of combinations

6.4.2.1 Alternative A: General approach for combinations

Combined equipment or a combination of a plug-in radio device and a specific type of host equipment may be used for testing according to the full requirements of the present document.

6.4.2.2 Alternative B: For host equipment with a plug-in radio device

A combination of a plug-in radio device and a specific type of host equipment may be used for testing according to the full requirements of the present document.

For radiated spurious emission tests the most appropriate harmonized EMC standard shall be applied to the host equipment. The plug-in radio device shall meet the radiated spurious emissions requirements as described in clause 9.1.

6.4.2.3 Alternative C: For combined equipment with a plug-in radio device

Combined equipment may be used for testing according to the full requirements of the present document.

For radiated other emissions the requirements of the most appropriate harmonized EMC standard shall be applied to the non-radio equipment. The plug-in radio device shall meet the radiated other emissions requirements as described in clause 9.1. In the case where the plug-in radio device is totally integrated and cannot operate independently, radiated emissions for the combination shall be tested using the most appropriate harmonized standard with the radio part in receive and/or standby mode. If the frequency range is less than the one defined in the present document, additional measurements shall be performed to cover the remaining parts of the frequency range. With the radio in transmit mode, the radiated emissions requirements of the present document shall be applied.

7 Interpretation of results

7.1 Measurement uncertainty

The interpretation of the results recorded in the test report for the measurements described in the present document shall be as follows:

- The measured value related to the corresponding limit shall be used to decide whether an equipment meets the requirements of the present document.
- The value of the measurement uncertainty for the measurement of each parameter shall be separately included in the test report.
- For each measurement, the value of the measurement uncertainty shall (wherever possible; see note below) be equal to or lower than the figures in table 1, and the interpretation procedure specified in clause 7.1.1 shall be used.

Table 1: Measurement uncertainty

Parameter	Value
Radio frequency	$\pm 1 \times 10^{-7}$
Radiated emission of transmitter, valid to 30 GHz	± 6 dB
Radiated emission of receiver, valid to 30 GHz	± 6 dB
Temperature	± 1 K
Humidity	± 10 %
NOTE: For radiated emissions measurements below 3,8 GHz and above 10,6 GHz it may not be possible to reduce measurement uncertainty to the levels specified in table 1 (due to the very low signal level limits and the consequent requirement for high levels of amplification across wide bandwidths). In these cases alone it is acceptable to employ the alternative interpretation procedure specified in clause 7.1.2.	

For the test methods, according to the present document the uncertainty figures shall be calculated according to the methods described in TR 100 028 [1] and shall correspond to an expansion factor (coverage factor) $k = 1,96$ or $k = 2$ (which provide confidence levels of respectively 95 % and 95,45 % in case where the distributions characterizing the actual measurement uncertainties are normal (Gaussian)).

Table 1 is based on such expansion factors.

The particular expansion factor used for the evaluation of the measurement uncertainty shall be stated.

7.1.1 Measurement uncertainty is equal to or less than maximum acceptable uncertainty

The interpretation of the results when comparing measurement values with specification limits shall be as follows:

- When the measured value does not exceed the limit value the equipment under test meets the requirements of the standard.
- When the measured value exceeds the limit value the equipment under test does not meet the requirements of the standard.
- The measurement uncertainty calculated by the test technician carrying out the measurement shall be recorded in the test report.
- The measurement uncertainty calculated by the test technician may be a maximum value for a range of values of measurement, or may be the measurement uncertainty for the specific measurement undertaken. The method used shall be recorded in the test report.

7.1.2 Measurement uncertainty is greater than maximum acceptable uncertainty

The interpretation of the results when comparing measurement values with specification limits shall be as follows:

- When the measured value plus the difference between the maximum acceptable measurement uncertainty and the measurement uncertainty calculated by the test technician does not exceed the limit value the equipment under test meets the requirements of the standard.
- When the measured value plus the difference between the maximum acceptable measurement uncertainty and the measurement uncertainty calculated by the test technician exceeds the limit value the equipment under test does not meet the requirements of the standard.
- The measurement uncertainty calculated by the test technician carrying out the measurement shall be recorded in the test report.
- The measurement uncertainty calculated by the test technician may be a maximum value for a range of values of measurement, or may be the measurement uncertainty for the specific measurement undertaken. The method used shall be recorded in the test report.

7.2 Other emissions

UWB transmitters emit very low power radio signals, comparable with the power of spurious emissions from digital and analogue circuitry. If it can be clearly demonstrated that an emission from an Ultra Wideband device is unintentional and is not radiated from the UWB antenna (e.g. by disabling the device's UWB transmitter or internally disconnecting the UWB antenna) or it can clearly be demonstrated that it is impossible to differentiate between other emissions and the UWB transmitter emissions, that emission or aggregated emissions shall be considered against the receiver spurious emissions limits (see clause 9.1.3, tables 7 and 8).

8 Methods of measurement and limits for transmitter parameters

8.1 Maximum mean e.i.r.p. spectral density

8.1.1 Definition

The maximum mean equivalent isotropically radiated power spectral density of the device under test at a particular frequency is the mean power per unit bandwidth (centred on that frequency) radiated in the direction of the maximum level under the specified conditions of measurement.

8.1.2 Methods of measurement

Measurements shall be made using one of the techniques presented in clause A.5.

The measurement receiver used shall be a spectrum analyser which meets at least the requirements of annex B.

Measurements shall be carried out over the frequency range from 30 MHz to 18 GHz (see note 3).

When measuring maximum mean e.i.r.p. spectral density from the device under test, the spectrum analyser used shall be configured as follows:

- Resolution bandwidth: 1 MHz
- Video bandwidth: Not less than the resolution bandwidth
- Detector mode: rms
- Average time (per point on spectrum analyzer scan): 1 ms or less

NOTE 1: rms average measurements can be accomplished directly using a spectrum analyser which incorporates an rms detector. Alternatively, a true rms level can be measured using a spectrum analyzer that does not incorporate an rms detector - see ITU-R Recommendation SM.1754 [i.1] for details.

NOTE 2: To the extent practicable, the device under test should be measured using a spectrum analyser configured using the settings described above. However, in order to obtain an adequate signal-to-noise ratio in the measurement system, radiated measurements may have to be made using narrower resolution bandwidths. In these cases, the revised measurement configuration should be stated in the test report, together with calculations which permit the measurements taken to be compared with the appropriate limits and an explanation of why the signal levels involved necessitated measurement using the resolution bandwidth employed in order to be accurately determined by the measurement equipment.

NOTE 3: The noise floor above the 18 GHz point rises so high that to get below the -85 dBm/MHz limit will require measurement distances in the mm range. Therefore, measurements above 18 GHz are not feasible with reasonable measurement certainty (see clause 7.1).

8.1.3 Limits

The maximum mean equivalent isotropically radiated power spectral densities measured using the above techniques shall not exceed the limits given in table 2.

Table 2: Maximum mean e.i.r.p. spectral density limit

Frequency range (GHz)	Maximum mean e.i.r.p. spectral density (dBm/MHz)
Below 1,6	-90
1,6 to 2,7	-85
2,7 to 3,4	-70
3,4 to 3,8	-80
3,8 to 4,8	-70
4,8 to 6	-70
6 to 8,5	-41,3
8,5 to 9	-41,3 (see note)
9 to 10,6	-65
Above 10,6	-85
NOTE: Operation is subject to the implementation of DAA. If DAA is not implemented, the following applies: 8,5 GHz to 9 GHz \leq -65 dBm/MHz.	

The power reading on the spectrum analyser can be directly related to the mean e.i.r.p. spectral density limit when a spectrum analyser resolution bandwidth of 1 MHz is used for the measurements.

8.2 Frequency of highest maximum mean e.i.r.p. spectral density

8.2.1 Definition

The frequency of highest maximum mean e.i.r.p. spectral density is the frequency at which the device radiates the highest maximum mean equivalent isotropically radiated power spectral density (across all frequencies and device orientations) under the specified conditions of measurement when the device is transmitting the normal test signal (clauses 6.1 and 6.2).

8.2.2 Methods of measurement

The methods of measurement described in clause 8.1.2 shall be used.

8.2.3 Limits

The frequency of highest maximum mean e.i.r.p. spectral density measured using the above techniques shall not be less than 6 GHz nor greater than 9 GHz.

8.3 Maximum peak e.i.r.p.

8.3.1 Definition

The maximum peak equivalent isotropically radiated power of the device under test at a particular frequency is the peak power (centred on that frequency) radiated in the direction of the maximum level under the specified conditions of measurement.

8.3.2 Methods of measurement

Measurements shall be made using one of the techniques presented in clause A.5.

The measurement receiver used shall be a spectrum analyzer which meets at least the requirements of annex B.

Measurements shall be carried out over the frequency range from 30 MHz to 18 GHz (see note 2).

When measuring maximum peak e.i.r.p. from the device under test, the spectrum analyser used shall be configured as follows:

- Frequency: The measurement within each band listed in table 3 shall be centred on the frequency at which the highest maximum mean e.i.r.p. spectral density occurs within that band (see clause 8.1).
- Resolution bandwidth: Not less than 3 MHz and not greater than 50 MHz for impulsive technology or equal to or greater than 10 MHz for carrier-based technology.
- Video bandwidth: Not less than the resolution bandwidth.
- Detector mode: Peak.
- Display mode: Max. Hold.
- Measurements shall be continued with the transmitter emitting the normal test signal (clauses 6.1 and 6.2) until the displayed trace no longer changes.

NOTE 1: To the extent practicable, the device under test should be measured using a spectrum analyser configured using the settings described above. However, in order to obtain an adequate signal-to-noise ratio in the measurement system, radiated measurements may have to be made using narrower resolution bandwidths. In these cases, the revised measurement configuration should be stated in the test report, together with calculations which permit the measurements taken to be compared with the appropriate limits and an explanation of why the signal levels involved necessitated measurement using the resolution bandwidth employed in order to be accurately determined by the measurement equipment.

NOTE 2: The noise floor above the 18 GHz point rises so high that to get below the -45 dBm (measured in a 50 MHz bandwidth) limit will require measurement distances in the mm range. Therefore, measurements above 18 GHz are not feasible with reasonable measurement certainty (see clause 7.1).

NOTE 3: For peak power measurements, the best signal to noise ratio is usually obtained with the widest available resolution bandwidth. However, at the time of writing the present document, there is no knowledge of a measurement receiver being capable of measuring impulsive peak powers with a 50 MHz RBW. Current upper RBW limits for impulsive emissions are in the order of 20 MHz to 25 MHz.

8.3.3 Limits

The maximum peak equivalent isotropically radiated power spectral densities measured using the above techniques shall not exceed the limits given in table 3.

Table 3: Maximum peak e.i.r.p. limit

Frequency (GHz)	Maximum peak e.i.r.p. (dBm, measured in 50 MHz bandwidth)
Below 1,6	-50
1,6 to 2,7	-45
2,7 to 3,4	-36
3,4 to 3,8	-40
3,8 to 4,8	-30
4,8 to 6	-30
6 to 8,5	0
8,5 to 9	0 (see note)
9 to 10,6	-25
Above 10,6	-45

NOTE: Operation is subject to the implementation of DAA. If DAA is not implemented, the following applies: 8,5 GHz to 9 GHz \leq -25 dBm (measured in 50 MHz bandwidth).

The power reading on the spectrum analyser can be directly related to the peak e.i.r.p. limit when a spectrum analyser resolution bandwidth of 50 MHz is used for the measurements. It is likely that the measurement of the maximum peak e.i.r.p. will be made using a spectrum analyser resolution bandwidth other than 50 MHz.

In this case, the maximum peak e.i.r.p. limit shall be adjusted by $20 \log(\text{RBW}/50)$ dBm where RBW is the resolution bandwidth in Megahertz that is employed. For example, if the maximum peak e.i.r.p. in a particular band is 0 dBm (measured in a 50 MHz bandwidth), and a 3 MHz resolution bandwidth is used, then the measured reading shall not exceed -24,4 dBm.

8.4 Indirect Detect-And-Avoid (DAA)

8.4.1 Introduction

UWB devices can be equipped with Detect and Avoid capability to prevent interference to Radar equipment operating in the range 8,5 GHz to 9 GHz. The capability ensures that the UWB device is not active in this band if Radar signals are also present (indicating that a sensitive Radar installation is nearby).

This capability is relatively expensive and power-hungry, and its implementation may not be feasible in the location tracking UWB transmit-only tags covered by the present document. However, such location tracking tags must work in the immediate vicinity of a sensor infrastructure consisting of receivers which detect the tag's signals, and it would be possible to implement the Detect-and-Avoid sensing mechanism on such receivers.

If tags are designed so that they will only transmit signals in the range 8,5 GHz to 9 GHz if they obtain an indication from a collocated receiver that no Radar signals are currently present in that band, then the protection requirements for Radar services operating in that band are maintained.

8.4.2 Design requirement

To minimize interference to other users of the radio spectrum, the equipment shall transmit only in Non-Interference Mode (NIM) unless it has received an indication that within the last 10s an associated collocated device which has DAA capability (as per [4] and [5]) has verified that non-NIM operation of the equipment is permissible.

8.4.3 Method of measurement

The manufacturer shall provide sufficient information for determining compliance with the design requirement of clause 8.4.2.

The maximum mean e.i.r.p. spectral density of the equipment shall be assessed using the methods of measurement described in clause 8.1.2, in both NIM and non-NIM operation modes.

The maximum peak e.i.r.p. of the equipment shall be assessed using the methods of measurement described in clause 8.3.2, in both NIM and non-NIM operation modes.

8.4.4 Limits

In Non-Interference Mode (NIM) operation, the maximum mean e.i.r.p. spectral density and maximum peak e.i.r.p. of the equipment shall not exceed the levels given in table 4a.

Table 4a: NIM limits for maximum mean e.i.r.p. spectral density and maximum peak e.i.r.p.

Frequency range (GHz)	Maximum mean e.i.r.p. spectral density (dBm/MHz)	Maximum peak e.i.r.p (dBm, measured in 50 MHz bandwidth)
8,5 to 9	-65	-25

In non-NIM operation, the maximum mean e.i.r.p. spectral density and maximum peak e.i.r.p. of the equipment shall not exceed the levels given in table 4b.

Table 4b: Non-NIM limits for maximum mean e.i.r.p. spectral density and maximum peak e.i.r.p.

Frequency range (GHz)	Maximum mean e.i.r.p. spectral density (dBm/MHz)	Maximum peak e.i.r.p (dBm, measured in 50 MHz bandwidth)
8,5 to 9	-41,3	0

9 Methods of measurement and limits for receiver parameters

9.1 Receiver spurious emissions

9.1.1 Definition

Receiver spurious emissions are emissions at any frequency from the equipment which are not attributed to the transmitter. These may be emissions from a receiver circuit on the device, or other emissions from the device which are treated in the same manner (see clause 7.2).

9.1.2 Test procedure

The level of spurious emissions radiated by cabinet and antenna shall be measured.

With the equipment in the receive/standby mode, the applicable spectrum shall be searched for emissions that exceed the limit values given in clause 9.1.3 or that come to within 6 dB below the limit values given in clause 9.1.3. Each occurrence shall be recorded.

Measurements shall be carried out over the frequency range from 30 MHz to 30 GHz.

Measurements shall be made using one of the techniques outlined in clauses A.5.1 or A.5.2.

Where these measurements are made with a spectrum analyser, the following settings shall be used for narrowband emissions:

- resolution BW: 100 kHz;
- video BW: 300 kHz;
- detector mode: positive peak;
- averaging: off;
- span: 100 MHz;
- amplitude: adjust for middle of the instrument's range;
- sweep time: 1 s.

For measuring emissions that exceed the level of 6 dB below the applicable limit, the resolution bandwidth shall be switched to 30 kHz and the span shall be adjusted accordingly. If the level does not change by more than 2 dB, it is a narrowband emission; the observed value shall be recorded. If the level changes by more than 2 dB, the emission is a wideband emission and its level shall be measured and recorded. The measurement result for wideband spurious emissions has to be recalculated for 1 MHz bandwidth.

9.1.3 Limit

The narrowband receiver spurious emissions shall not exceed the values in tables 5 and 6 in the indicated bands.

Table 5: Narrowband spurious emission limits for receivers

Frequency range	Limit
30 MHz to 1 GHz	-57 dBm (e.r.p.)
above 1 GHz to 30 GHz	-47 dBm (e.i.r.p.)

The above limit values apply to narrowband emissions, e.g. as caused by local oscillator leakage. The measurement bandwidth for such emissions may be as small as necessary to get a reliable measurement result.

Wideband spurious emissions shall not exceed the values given in table 6.

Table 6: Wideband spurious emission limits for receivers

Frequency range	Limit
30 MHz to 1 GHz	-47 dBm/MHz (e.r.p.)
above 1 GHz to 30 GHz	-37 dBm/MHz (e.i.r.p.)

Annex A (normative): Radiated measurement

A.1 Test sites and general arrangements for measurements involving the use of radiated fields

This clause introduces three commonly available test sites, an anechoic chamber, an anechoic chamber with a ground plane, and an open-area test site, which may be used for radiated tests. These test sites are generally referred to as free field test sites. Both absolute and relative measurements can be performed in these sites. Where absolute measurements are to be carried out, the site should be verified. A detailed verification procedure is described in the relevant parts of TR 102 273 [i.3] or equivalent.

NOTE: To ensure reproducibility and tractability of radiated measurements only these test sites should be used in measurements in accordance with the present document.

A.1.1 Anechoic chamber

An anechoic chamber is an enclosure, usually shielded, whose internal walls, floor and ceiling are covered with radio absorbing material, normally of the pyramidal urethane foam type. The chamber usually contains an antenna support at one end and a turntable at the other. A typical anechoic chamber is shown in figure A.1.

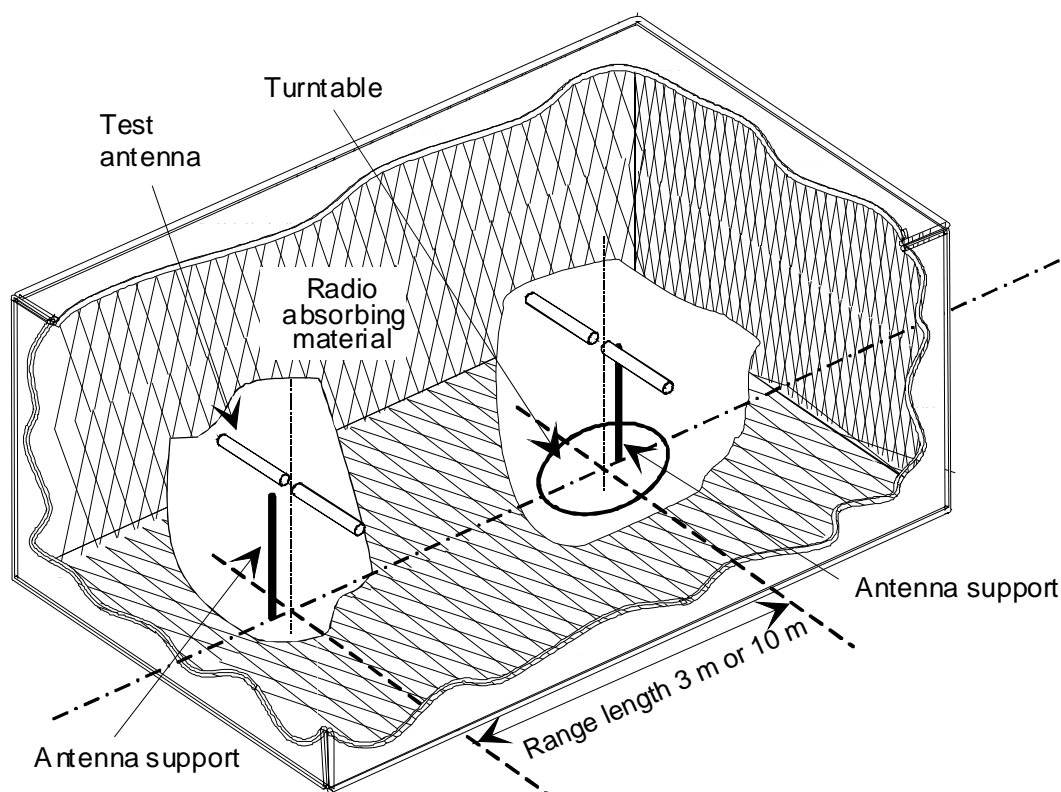

NOTE 1: The test antenna may be chosen according to clause A.1.4.

NOTE 2: The Range length may vary according to the test frequency.

Figure A.1: A typical anechoic chamber

The chamber shielding and radio absorbing material work together to provide a controlled environment for testing purposes. This type of test chamber attempts to simulate free space conditions.

The shielding provides a test space, with reduced levels of interference from ambient signals and other outside effects, whilst the radio absorbing material minimizes unwanted reflections from the walls and ceiling which can influence the measurements. In practice it is relatively easy for shielding to provide high levels (80 dB to 140 dB) of ambient interference rejection, normally making ambient interference negligible.

A turntable is capable of rotation through 360° in the horizontal plane and it is used to support the test sample (EUT) at a suitable height (e.g. 1 m) above the ground plane. The chamber shall be large enough to allow the measuring distance of at least 3 m or $2(d_1+d_2)^2 / \lambda$ (m), whichever is greater (see clause A.2.4). The distance used in actual measurements shall be recorded with the test results. Practical tests have shown that larger measurement distances of about 3 metres at the frequencies below 1 GHz and shorter measurement distances of less than 1 metre can be conducted as long as the far field conditions are still fulfilled.

The anechoic chamber generally has several advantages over other test facilities. There is minimal ambient interference, minimal floor, ceiling and wall reflections and it is independent of the weather. It does however have some disadvantages which include limited measuring distance and limited lower frequency usage due to the size of the pyramidal absorbers. To improve low frequency performance, a combination structure of ferrite tiles and urethane foam absorbers is commonly used.

All types of emission, sensitivity and immunity testing can be carried out within an anechoic chamber without limitation.

A.1.2 Anechoic chamber with a conductive ground plane

An anechoic chamber with a conductive ground plane is an enclosure, usually shielded, whose internal walls and ceiling are covered with radio absorbing material, normally of the pyramidal urethane foam type. The floor, which is metallic, is not covered and forms the ground plane. The chamber usually contains an antenna mast at one end and a turntable at the other. A typical anechoic chamber with a conductive ground plane is shown in figure A.2.

This type of test chamber attempts to simulate an ideal open area test site whose primary characteristic is a perfectly conducting ground plane of infinite extent.

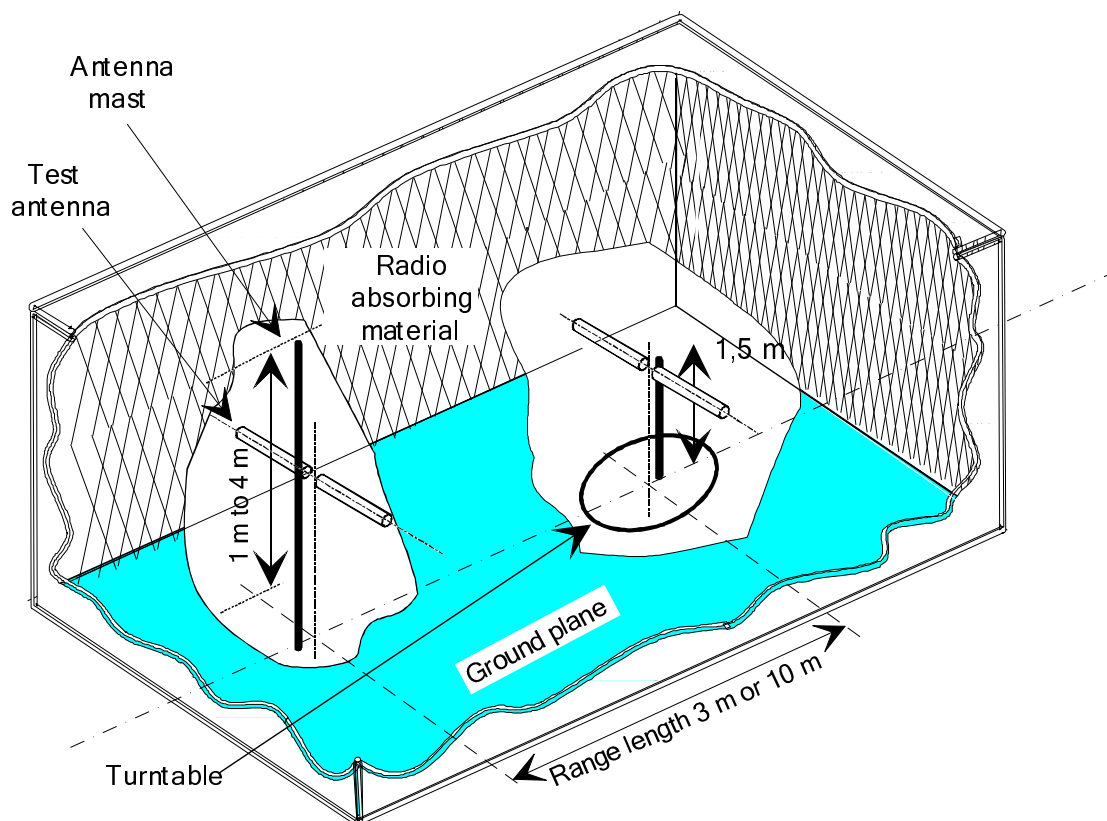

Figure A.2: A typical anechoic chamber with a conductive ground plane

In this facility the ground plane creates the wanted reflection path, such that the signal received by the receiving antenna is the sum of the signals from both the direct and reflected transmission paths. This creates a unique received signal level for each height of the transmitting antenna (or EUT) and the receiving antenna above the ground plane.

The antenna mast provides a variable height facility (from 1 m to 4 m) so that the position of the test antenna can be optimized for maximum coupled signal between antennas or between an EUT and the test antenna.

A turntable is capable of rotation through 360° in the horizontal plane and it is used to support the test sample (EUT) at a specified height, usually 1,5 m above the ground plane. The chamber shall be large enough to allow the measuring distance of at least 3 m or $2(d_1+d_2)^2 / \lambda$ (m), whichever is greater (see clause A.2.4). The distance used in actual measurements shall be recorded with the test results.

Emission testing involves firstly "peaking" the field strength from the EUT by raising and lowering the receiving antenna on the mast (to obtain the maximum constructive interference of the direct and reflected signals from the EUT) and then rotating the turntable for a "peak" in the azimuth plane. At this height of the test antenna on the mast, the amplitude of the received signal is noted. Secondly the EUT is replaced by a substitution antenna (positioned at the EUT's phase or volume centre) which is connected to a signal generator. The signal is again "peaked" and the signal generator output adjusted until the level, noted in stage one, is again measured on the receiving device.

Receiver sensitivity tests over a ground plane also involve "peaking" the field strength by raising and lowering the test antenna on the mast to obtain the maximum constructive interference of the direct and reflected signals, this time using a measuring antenna which has been positioned where the phase or volume centre of the EUT will be during testing. A transform factor is derived. The test antenna remains at the same height for stage two, during which the measuring antenna is replaced by the EUT. The amplitude of the transmitted signal is reduced to determine the field strength level at which a specified response is obtained from the EUT.

A.1.3 Outdoor test site

An outdoor test site, see figure A.3, shall provide:

- Measured support positions at least 3 m or $\lambda/2$ (at the test frequency) apart for the test item or substitution antenna and the test antenna, and a measured midpoint.
- A clear area greater than a circle of diameter twice the separation of the test item or substitution antenna from the test antenna, centred at the midpoint.
- Substantially level ground surface treated to render its effect either negligible (treatment to minimize reflection) or deterministic (treatment with flat reflecting material) and including the whole of the clear area.
- Sufficient precautions to ensure that reflections from extraneous objects beyond the clear area and within or adjacent to the site do not degrade the measurement results in accordance with CISPR 16-1-1 [2].
- Non-conducting supports for the test item or substitution antenna and the test antenna.
- Provision for free-mounting equipment under test to be supported 1,5 m above the ground and rotated through 360° in the horizontal plane.
- Provision for floor-standing equipment to be mounted 100 mm above the ground and rotated through 360° in the horizontal plane.
- Provision for the test antenna to be moved between heights of at least 1 m to 4 m above the treated ground surface and rotated for operation in any plane of polarization.

Key:

- 1) equipment under test;
- 2) test antenna;
- 3) high pass filter (if necessary);
- 4) spectrum analyser or measuring receiver.

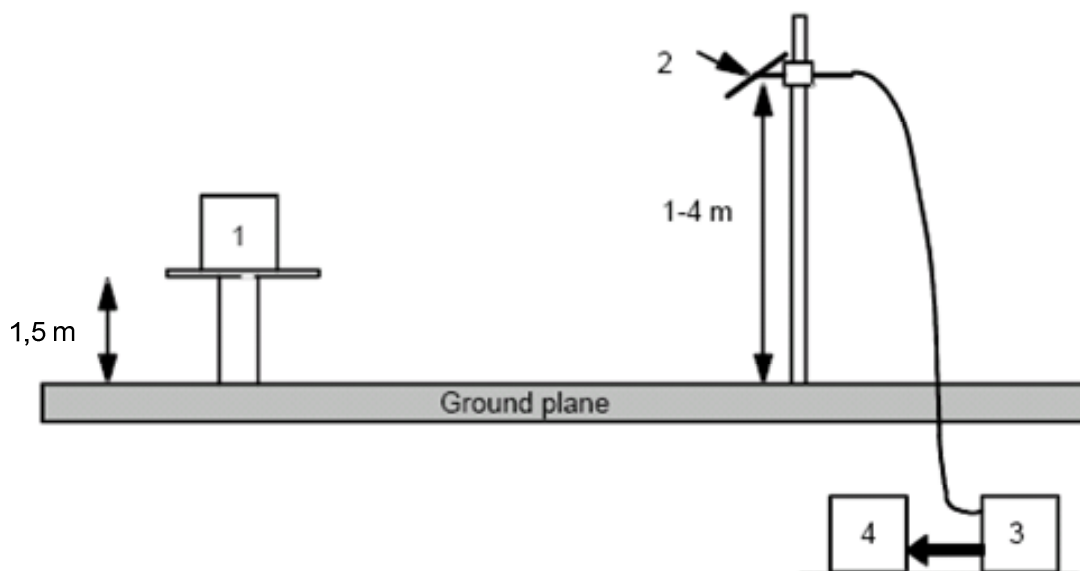

Figure A.3: Outdoor test site

A.1.4 Test antenna

A test antenna shall always be used in radiated test methods. In emission tests (i.e. frequency error, equivalent isotropically radiated power and spurious emissions) the test antenna is used to detect the field from the EUT in one stage of the measurement and from the substitution antenna in the other stage. When the test site is used for the measurement of receiver characteristics (i.e. sensitivity and various immunity parameters) the antenna is used as the transmitting device.

The test antenna should be mounted on a support capable of allowing the antenna to be used in either horizontal or vertical polarization. In the frequency band 30 MHz to 1 000 MHz, dipole antennas (constructed in accordance with ANSI C63.5 [3] are generally recommended). For frequencies of 80 MHz and above, the dipoles should have their arm lengths set for resonance at the frequency of test. Below 80 MHz, shortened arm lengths are recommended. For spurious emission testing, however, a combination of bicones and log periodic dipole array antennas (commonly termed "log periodics") could be used to cover the entire 30 MHz to 1 000 MHz band. Above 1 000 MHz, waveguide horns are recommended although, again, log periodics could be used.

The smallest available test antenna suitable for measurement at a particular frequency should be used wherever practical, to ensure that the region in which far field effects of the equipment under test are measured extends as close to the test antenna as possible. This will ensure that the measurement noise floor can be reduced to the greatest extent possible. Where the test antenna is electrically large compared to the wavelength λ of the emissions under test (the test antenna having a maximum dimension D), the radius r of the near field/far field boundary around the test antenna is given by:

$$r = 2D^2/\lambda$$

NOTE: The gain of a horn antenna is generally expressed relative to an isotropic radiator.

A.1.5 Substitution antenna

The substitution antenna shall be used to replace the EUT for tests in which a transmitting parameter (i.e. equivalent isotropically radiated power and spurious emissions) is being measured. For measurements in the frequency band 30 MHz to 1 000 MHz, the substitution antenna should be a dipole antenna (constructed in accordance with ANSI C63.5 [3] is generally recommended). For frequencies of 80 MHz and above, the dipoles should have their arm lengths set for resonance at the frequency of test. Below 80 MHz, shortened arm lengths are recommended. For measurements above 1 000 MHz, a waveguide horn is recommended. The centre of this antenna should coincide with either the phase centre or volume centre.

A.2 Guidance on the use of radiation test sites

This clause details procedures, test equipment arrangements and verification that should be carried out before any of the radiated test are undertaken. These schemes are common to all types of test sites described in annex A.

A.2.1 Verification of the test site

No test should be carried out on a test site which does not possess a valid certificate of verification. The verification procedures for the different types of test sites described in annex A (i.e. anechoic chamber and anechoic chamber with a ground plane) are given in the relevant parts of TR 102 273 [i.3] or equivalent.

A.2.2 Preparation of the EUT

The provider should supply information about the EUT covering the operating frequency, polarization, supply voltage(s) and the reference face. Additional information, specific to the type of EUT should include, where relevant, carrier power, channel separation, whether different operating modes are available (e.g. high and low power modes) and if operation is continuous or is subject to a maximum test duty cycle (e.g. 1 minute on, 4 minutes off).

Where necessary, a mounting bracket of minimal size should be available for mounting the EUT on the turntable. This bracket should be made from low conductivity, low relative dielectric constant (i.e. less than 1,5) material(s) such as expanded polystyrene, dry balsa wood, etc.

A.2.3 Power supplies to the EUT

All tests should be performed using power supplies wherever possible, including tests on EUT designed for battery-only use. In all cases, power leads should be connected to the EUT's supply terminals (and monitored with a digital voltmeter) but the battery should remain present, electrically isolated from the rest of the equipment, possibly by putting tape over its contacts. If the device design and chosen battery support long duration tests without noticeable drop then the test can be carried out with internal battery (see clause 5.2.2).

For measurements with external batteries, the presence of power cables can, however, affect the measured performance of the EUT. For this reason, they should be made to be "transparent" as far as the testing is concerned. This can be achieved by routing them away from the EUT and down to the either the screen, or facility wall (as appropriate) by the shortest possible paths. Precautions should be taken to minimize pick-up on these leads (e.g. the leads could be twisted together, loaded with ferrite beads at 0,15 m spacing or otherwise loaded).

A.2.4 Range length

The range length for all these types of test facility should be adequate to allow for testing in the far-field of the EUT i.e. it should be equal to or exceed:

$$\frac{2(d_1 + d_2)^2}{\lambda}$$

where:

d_1 is the largest dimension of the EUT/dipole after substitution (m);

d_2 is the largest dimension of the test antenna (m);

λ is the test frequency wavelength (m).

Tests should preferentially be made at a distance of 3 m or $2(d_1+d_2)^2 / \lambda$ (m), whichever is greater.

It should be noted that in the substitution part of this measurement, where both test and substitution antennas are half wavelength dipoles, this minimum range length for far-field testing would be:

$$2\lambda$$

It should be noted in the test report when either of these conditions is not met so that the additional measurement uncertainty can be incorporated into the results.

NOTE 1: **For the fully anechoic chamber**, no part of the volume of the EUT should, at any angle of rotation of the turntable, fall outside the "quiet zone" of the chamber at the nominal frequency of the test.

NOTE 2: The "quiet zone" is a volume within the **fully anechoic chamber** in which a specified performance has either been proven by test, or is guaranteed by the designer/manufacture. The specified performance is usually the reflectivity of the absorbing panels or a directly related parameter (e.g. signal uniformity in amplitude and phase). It should be noted however that the defining levels of the quiet zone tend to vary.

NOTE 3: **For the anechoic chamber with a ground plane**, a full height scanning capability, i.e. 1 m to 4 m, should be available for which no part of the test antenna should come within 1 m of the absorbing panels.

NOTE 4: **For both the anechoic chamber, with and without a ground plane**, no part of any antenna should come within 0,25 m of the ground plane at any time throughout the tests. Where any of these conditions cannot be met, measurements should not be carried out.

NOTE 5: **For both the anechoic chamber, with and without a ground plane**, the reflectivity of any absorbing panels should not be worse than -5 dB.

A.2.5 Site preparation

The cables for both ends of the test site should be routed horizontally away from the testing area for a minimum of 2 m and then allowed to drop vertically and out through either the ground plane or screen (as appropriate) to the test equipment. Precautions should be taken to minimize pick up on these leads (e.g. dressing with ferrite beads, or other loading). The cables, their routing and dressing should be identical to the verification set-up.

Calibration data for all items of test equipment should be available and valid. For test, substitution and measuring antennas, the data should include gain relative to an isotropic radiator (or antenna factor) for the frequency of test. Also, the VSWR of the substitution and measuring antennas should be minimized and known.

The calibration data on all cables and attenuators should include insertion loss and VSWR throughout the entire frequency range of the tests. All VSWR and insertion loss figures should be recorded in the log book results sheet for the specific test.

Where correction factors/tables are required, these should be immediately available.

For all items of test equipment, the maximum errors they exhibit should be known along with the distribution of the error e.g.:

- cable loss: $\pm 0,5$ dB with a rectangular distribution;
- spectrum analyser: 1,0 dB (standard deviation) signal level accuracy with a Gaussian error distribution.

At the start of measurements, system checks should be made on the items of test equipment used on the test site.

A.2.6 General requirements for RF cables

Due to the low power levels involved in the measurements, all RF cables including their connectors at both ends used within the measurement arrangements and set-ups shall be of coaxial type featuring within the frequency range they are used:

- a nominal characteristic impedance of 50 Ω ;
- a VSWR of less than 1,2 at either end;
- a shielding loss in excess of 60 dB.

A.3 Coupling of signals

A.3.1 General

The presence of leads in the radiated field may cause a disturbance of that field and lead to additional measurement uncertainty. These disturbances can be minimized by using suitable coupling methods, offering signal isolation and minimum field disturbance (e.g. optical and acoustic coupling).

A.3.2 Data Signals

Isolation can be provided by the use of optical, Ultra Wideband (UWB) sonic or infra red means. Field disturbance can be minimized by using a suitable fibre optic connection. Ultra Wideband (UWB) sonic or infra red radiated connections require suitable measures for the minimization of ambient noise.

A.4 Standard test position

The standard position in all test sites for equipment which is not intended to be worn on a person, including hand-held equipment, shall be on a non conducting support with an ϵ_r as close as possible to one, height 1,5 m, capable of rotating about a vertical axis through the equipment. The standard position of the equipment shall be the following:

- a) for equipment with an internal antenna, it shall be placed in the position closest to normal use as declared by the provider;
- b) for equipment with a rigid external antenna, the antenna shall be vertical;
- c) for equipment with a non-rigid external antenna, the antenna shall be extended vertically upwards by a non-conducting support.

Equipment which is intended to be worn on a person may be tested using a simulated man as support.

The simulated man comprises a rotatable acrylic tube filled with salt water, placed on the ground.

The container shall have the following dimensions:

- Height: 1,7 m \pm 0,1 m;
- Inside diameter: 300 mm \pm 5 mm;
- Sidewall thickness: 5 mm \pm 0,5 mm.

The container shall be filled with a salt (NaCl) solution of 1,5 g per litre of distilled water.

The equipment shall be fixed to the surface of the simulated man, at the appropriate height for the equipment.

NOTE: To reduce the weight of the simulated man it may be possible to use an alternative tube which has a hollow centre of 220 mm maximum diameter.

A.5 Standard test methods

For equipment which can be presented for testing with a 50 Ohm antenna connector, conducted transmitter measurements can be made providing suitable antenna calibrations data are available. See clause A.5.3.

A.5.1 Calibrated setup

The measurement receiver, test antenna and all associated equipment (e.g. cables, filters, amplifiers, etc.) shall have been recently calibrated against known standards at all the frequencies on which measurements of the equipment are to be made. A suggested calibration method is given in clause A.6.

On a test site according to clause A.1, the equipment shall be placed at the specified height on a support, and in the position closest to normal use as declared by the provider.

The test antenna shall be oriented initially for vertical polarization and shall be chosen to correspond to the frequency of the transmitter.

The output of the test antenna shall be connected to the spectrum analyser via whatever (fully characterized) equipment is required to render the signal measurable (e.g. amplifiers).

The transmitter shall be switched on, and the spectrum analyser shall be tuned to the frequency of the transmitter under test.

The test antenna shall be raised and lowered through the specified range of height until a maximum signal level is detected by the spectrum analyser.

The transmitter shall then be rotated through 360° in the horizontal plane, until the maximum signal level is detected by the spectrum analyser.

The test antenna shall be raised and lowered again through the specified range of height until a maximum signal level is detected by the spectrum analyser.

The maximum signal level detected by the spectrum analyser shall be noted and converted into the radiated power by application of the pre-determined calibration coefficients for the equipment configuration used.

A.5.2 Substitution method

On a test site, selected from clause A.1, the equipment shall be placed at the specified height on a support, as specified in clause A.1, and in the position closest to normal use as declared by the provider.

The test antenna shall be oriented initially for vertical polarization and shall be chosen to correspond to the frequency of the transmitter.

The output of the test antenna shall be connected to the spectrum analyser.

The transmitter shall be switched on, and the measuring receiver shall be tuned to the frequency of the transmitter under test.

The test antenna shall be raised and lowered through the specified range of height until a maximum signal level is detected by the spectrum analyser.

The transmitter shall then be rotated through 360° in the horizontal plane, until the maximum signal level is detected by the spectrum analyser.

The test antenna shall be raised and lowered again through the specified range of height until a maximum signal level is detected by the spectrum analyser.

The maximum signal level detected by the spectrum analyser shall be noted.

The transmitter shall be replaced by a substitution antenna as defined in clause A.1.5.

The substitution antenna shall be orientated for vertical polarization and the length of the substitution antenna shall be adjusted to correspond to the frequency of the transmitter.

The substitution antenna shall be connected to a calibrated signal generator.

If necessary, the input attenuator setting of the spectrum analyser shall be adjusted in order to increase the sensitivity of the spectrum analyser.

The test antenna shall be raised and lowered through the specified range of height to ensure that the maximum signal is received. When a test site according to clause A.1.1 is used, the height of the antenna shall not be varied.

The input signal to the substitution antenna shall be adjusted to the level that produces a level detected by the spectrum analyser, that is equal to the level noted while the transmitter radiated power was measured, corrected for the change of input attenuator setting of the spectrum analyser.

The input level to the substitution antenna shall be recorded as power level, corrected for any change of input attenuator setting of the spectrum analyser.

The measurement shall be repeated with the test antenna and the substitution antenna orientated for horizontal polarization.

The measure of the radiated power of the device is the larger of the two levels recorded at the input to the substitution antenna, corrected for gain of the substitution antenna if necessary.

A.5.3 Conducted method

Equipment shall be presented for testing with a 50 Ohm antenna connector which temporarily replaces the integral or dedicated antenna normally used with the device.

Prior to testing, the gain characteristics of the integrated or dedicated antenna normally used with the device shall have been assessed (driven from a 50 Ohm feed) at the frequencies on which measurements of the equipment are to be made. The measurement receiver and all associated equipment (e.g. cables, filters, amplifiers, etc.) shall have been recently calibrated against known standards at all the frequencies on which measurements of the equipment are to be made. A suggested calibration method is given in clause A.6.

The equipment shall be connected via its temporary 50 Ohm antenna port to the spectrum analyzer via whatever (fully characterized) equipment is required to render the signal measurable (e.g. amplifiers).

The transmitter shall be switched on, and the spectrum analyzer shall be tuned to the frequency of the transmitter under test.

The maximum signal level detected by the spectrum analyzer shall be noted and converted into the radiated power by application of both the known gain at the frequency under test of the integral or dedicated antenna normally used with the device, and the pre-determined calibration coefficients for the equipment configuration used.

A.6 Standard calibration method

The calibration of the test fixture establishes the relationship between the detected output from the test fixture, and the transmitted power (as sampled at the position of the antenna) from the EUT in the test fixture. This can be achieved (at higher frequencies) by using a calibrated horn with a gain of equal to or less than 20 dB, fed from an external signal source, in place of the EUT to determine the variations in detected power over frequency.

The calibration setup is shown in figure A.4.

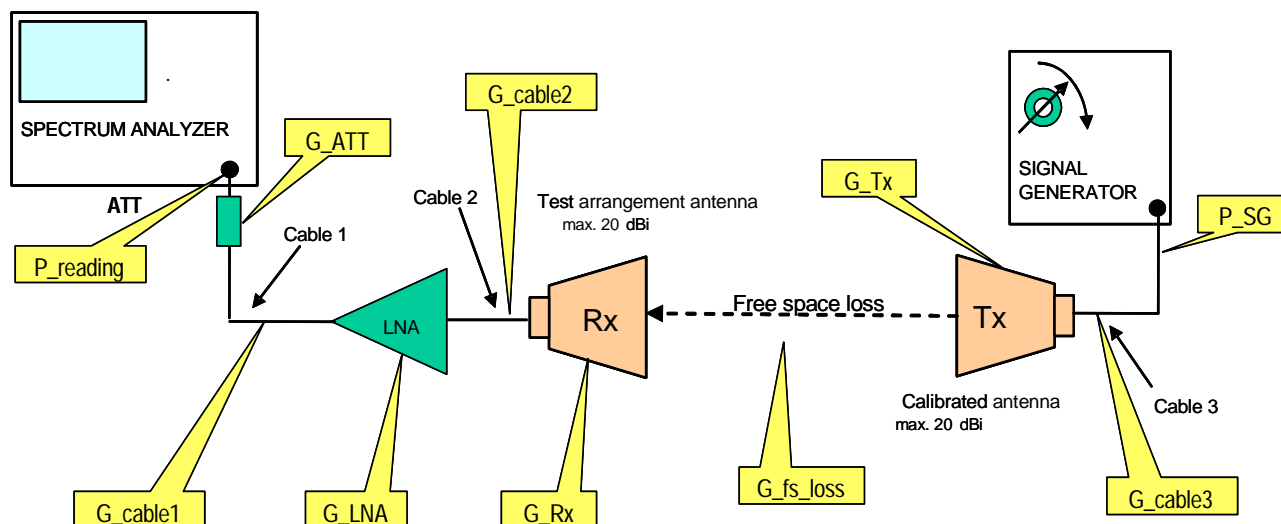

Figure A.4: Calibration set-up configuration

The calibration of the test fixture shall be carried out by either the provider or the accredited test laboratory. The results shall be approved by the accredited test laboratory.

It is the responsibility of the tester to obtain enough measurement accuracy. The following description is an example of a proven and accurate calibration method:

- a) Calibrate all instruments using usual calibration routines.

- b) Remove the EUT from the test fixture and replace the EUT by a calibrated antenna. Carefully orientate the calibration antenna in the test fixture towards the test arrangement antenna. The reference plane of the calibration antenna shall coincide with the EUT reference plane. The distance between the calibration antenna and the test arrangement antenna shall be between 0,5 m to 1 m.
- c) Connect a signal generator to the calibrated antenna in the test fixture.
- d) Connect a 10 dB attenuator to the test arrangement antenna to improve the VSWR. If SNR of the test arrangement is low it might be necessary to omit the attenuator.
- e) Connect a power meter to the test arrangement antenna including a 10 dB attenuator, if required, and apply, by means of a signal generator, a frequency and power level to the same as the expected value from the EUT output to the calibration antenna in the test fixture.
- f) Take into account the gain from both the calibration and the test arrangement antenna, the losses from the attenuator and all cables in use and the gain of a LNA, if required.
- g) Note the absolute reading of the power meter.
- h) Replace the power meter with a spectrum analyser. Adjust the frequency and power level of the signal generator to the same as the expected value from the EUT output. Apply this signal to the calibration antenna.
- i) Take into account the gain from both the calibration and the test arrangement antenna, the losses from the attenuator and all cables in use and the gain of a LNA, if required. Instead of an external attenuator the built-in attenuator of the spectrum analyser may be used.
- j) Set the spectrum analyser detector in rms mode with a RBW and VBW at least as large as the signal generator output signal bandwidth with an appropriate spectrum analyser sweep rate. Note the absolute reading of the spectrum analysers input signal.
- k) The noted absolute power reading of the power meter and the spectrum analyser shall not differ more than the specified uncertainty of the used measurement equipments.
- l) Calculate the total attenuation from the EUT reference plane to the spectrum analyser as follows:

P_{reading} = the absolute power level noted from the power meter/spectrum analyser.

G_{Tx} = antenna gain of the calibrated antenna in the test fixture.

G_{Rx} = antenna gain of the test arrangement antenna.

G_{ATT} = the 10 dB attenuator loss (0 dB, if attenuator not used).

G_{cable} = the total loss of all cables used in the test setup.

G_{LNA} = the gain of the low noise amplifier (0 dB, if LNA not used).

$G_{\text{fs_loss}}$ = the free space loss between the calibrated antenna (Tx) in the test fixture and the test arrangement antenna (Rx).

C_{ATT} = calculated attenuation of all losses with referenced to the EUT position.

P_{abs} = the absolute power of the EUT (e.i.r.p.).

C_{ATT} = $G_{\text{fs_loss}} - G_{\text{Rx}} + G_{\text{cable2}} - G_{\text{LNA}} + G_{\text{cable1}} + G_{\text{ATT}}$.

P_{abs} = $P_{\text{reading}} - C_{\text{ATT}}$.

The calibration should be carried out at a minimum of three frequencies within the operating frequency band.

Annex B (normative): Technical performance of the spectrum analyser

Methods of measurement in clauses 8.1 to 8.3 and 9.1 refer to the use of a spectrum analyser. The characteristics of the spectrum analyser shall meet at least the following requirements:

- the reading accuracy of the frequency marker shall be within ± 100 Hz;
- the accuracy of relative amplitude measurements shall be within $\pm 3,5$ dB.

It shall be possible to adjust the spectrum analyser to allow the separation on its screen of two equal amplitude components with a frequency difference of 100 Hz.

For the purposes of measuring the maximum mean e.i.r.p. spectral density and maximum peak e.i.r.p. the spectrum analyser used shall have adequate bandwidth to measure a signal modulated using the type of modulation used.

Annex C (informative): Measurement antenna and preamplifier specifications

The radiated measurements set-up specifies the use of a horn antenna and a wide-band, high gain preamplifier above 1 GHz in order to measure the very low radiated power spectral density level from UWB equipment.

Table C.1 gives examples of recommended data and features for the horn antenna and preamplifier to be used for the test set-up.

Table C.1: Recommended performance data for preamplifier and horn antenna

Pre-amplifier	
Parameter	Data
Bandwidth	< 1 GHz to > 15 GHz
Noise figure	< 2 dB
Output at 1 dB compression	> +10 dBm
Gain	> 30 dB (see note)
Gain flatness across band	±1,5 dB
Phase response	Linear across frequency range
Impulse response overshoot	< 10 %
Impulse response damping ratio	0,3 to 0,5
VSWR in/out across band	2:1
Nominal impedance	50 Ω
Horn antenna	
Parameter	Data
Gain	> 10 dBi (see note)
1 dB bandwidth	< 1 GHz to > 15 GHz
Nominal impedance	50 Ω
VSWR across band	< 1,5:1
Cross polarization	> 20 dB
Front to back ratio	> 20 dB
Tripod mountable	Yes
Robust precision RF connector	Yes
NOTE:	The combination of preamplifier and horn antenna should give an overall equivalent gain of about 40 dB without overloading the spectrum analyser. The noise floor of the combined equipment should be at least 6 dB below the limits specified in the radiated tests given in the present document.

Annex D (informative): Calculation of peak limit for 3 MHz measurement bandwidth

For impulsive modulation schemes the present document specifies a fixed maximum limit for average power in a 1 MHz bandwidth. The relationship between the PRF and the peak power to average power ratio is given in figure D.1.

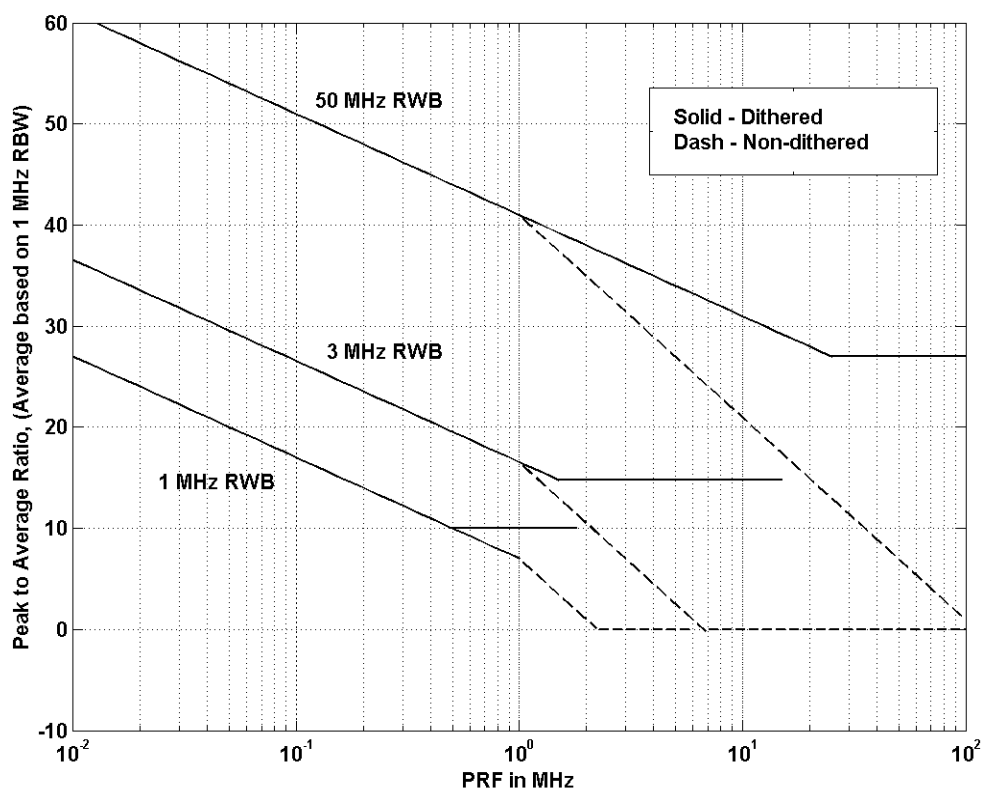

Figure D.1: Peak to average power versus PRF

For a noise like signal (e.g. dithered pulses) the roll-off rate is -10 dB/decade with a break point at half of the resolution bandwidth. Consequently, the breakpoints for 50 MHz, 3 MHz and 1 MHz resolution bandwidths are 25 MHz, 1,5 MHz and 0,5 MHz respectively.

As a peak measurement using a 50 MHz resolution bandwidth is difficult to impossible to conduct, the peak power is measured with a 3 MHz resolution bandwidth.

The curve for 3 MHz resolution bandwidth is $20 \log(BW\ 50\ \text{MHz}/BW\ 3\ \text{MHz}) = 24,4\ \text{dB}$ lower than for a 50 MHz resolution bandwidth. A peak limit of 0 dBm at 50 MHz will consequently be reduced correspondingly by 24,4 dB to -24,4 dBm.

As the dithered limit values are almost identical below and above 1 MHz PRF (within $\pm 1\ \text{dB}$). For a 3 MHz measuring bandwidth the peak limit is adjusted to -25 dBm within the entire range for PRF.

The resulting Peak limit is shown in figure D.2.

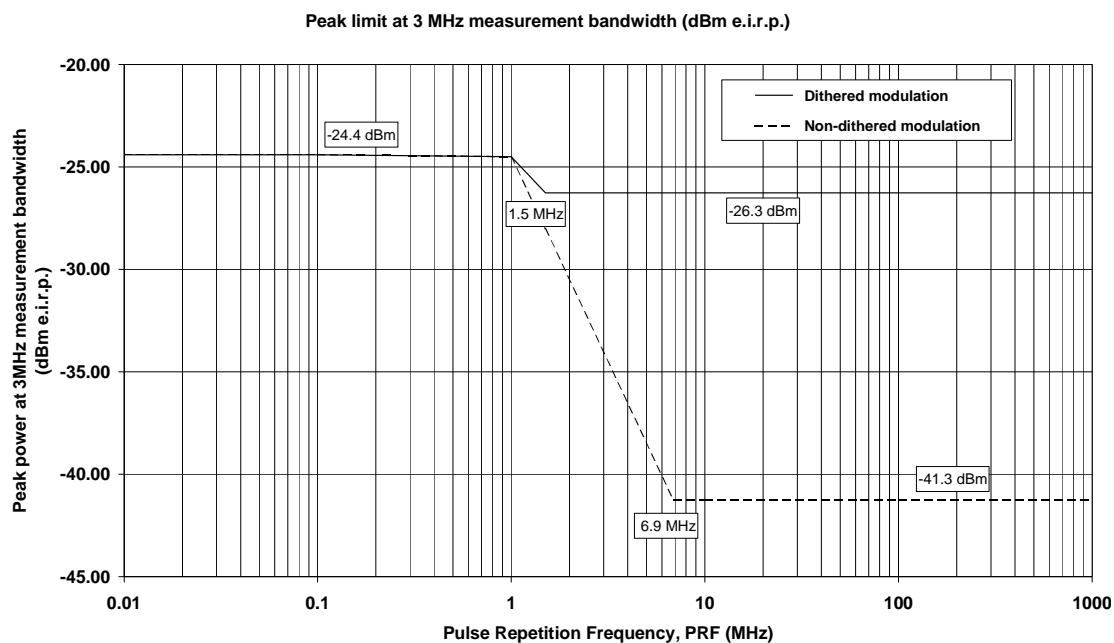

Figure D.2: Peak power limit in a 3 MHz bandwidth

Non-dithered modulation does not have the characteristics of a noise like spread spectrum but contains instead higher-level non-spread spectrum lines. To protect against these non-dithered spectrum lines the Peak limit is reduced further for PRF frequencies above 1 MHz by an additional -20 dB/decade roll-off until the peak to average ratio is zero. The resulting peak limit at 3 MHz is identical to the average limit in 1 MHz bandwidth for PRF above approximately 6,9 MHz.

Annex E (informative): Bibliography

Ketterling, H-P: "Verification of the performance of fully and semi-anechoic chambers for radiation measurements and susceptibility/immunity testing", 1991, Leatherhead/Surrey.

ETSI EN 301 489-3: "Electromagnetic compatibility and Radio spectrum Matters (ERM); ElectroMagnetic Compatibility (EMC) standard for radio equipment and services; Part 3: Specific conditions for Short-Range Devices (SRD) operating on frequencies between 9 kHz and 40 GHz".

ETSI TR 102 495-3: "Electromagnetic compatibility and Radio spectrum Matters (ERM); Short Range Devices (SRD); Technical characteristics for SRD equipment using Ultra Wide Band Sensor technology (UWB); System Reference Document, Part 3: Location tracking applications operating in the frequency band from 6 GHz to 9 GHz".

Directive 1999/5/EC of the European Parliament and of the Council of 9 March 1999 on radio equipment and telecommunications terminal equipment and the mutual recognition of their conformity (R&TTE Directive).

ECC/DEC/(06)04: "ECC Decision of 24 March 2006 amended 6 July 2007 on the harmonized conditions for devices using Ultra-Wideband (UWB) technology in bands below 10.6 GHz".

CEPT/ERC/REC 70-03: "Relating to the use of Short Range Devices (SRD)".

History

Document history		
V1.1.1	February 2007	Publication
V1.2.1	June 2008	Publication
V2.1.1	January 2010	Public Enquiry PE 20100511: 2010-01-11 to 2010-05-11
V2.1.1	August 2010	Vote V 20101005: 2010-08-06 to 2010-10-05
V2.1.1	October 2010	Publication