

ETSI EN 302 326-1 V1.1.1 (2005-12)

European Standard (Telecommunications series)

Fixed Radio Systems; Multipoint Equipment and Antennas; Part 1: Overview and Requirements for Digital Multipoint Radio Systems



Reference

DEN/TM-04130-1

Keywords

access, DFRS, DRRS, FWA, multipoint, radio,
system

ETSI

650 Route des Lucioles
F-06921 Sophia Antipolis Cedex - FRANCE

Tel.: +33 4 92 94 42 00 Fax: +33 4 93 65 47 16

Siret N° 348 623 562 00017 - NAF 742 C
Association à but non lucratif enregistrée à la
Sous-Préfecture de Grasse (06) N° 7803/88

Important notice

Individual copies of the present document can be downloaded from:

<http://www.etsi.org>

The present document may be made available in more than one electronic version or in print. In any case of existing or perceived difference in contents between such versions, the reference version is the Portable Document Format (PDF). In case of dispute, the reference shall be the printing on ETSI printers of the PDF version kept on a specific network drive within ETSI Secretariat.

Users of the present document should be aware that the document may be subject to revision or change of status. Information on the current status of this and other ETSI documents is available at

<http://portal.etsi.org/tb/status/status.asp>

If you find errors in the present document, please send your comment to one of the following services:

http://portal.etsi.org/chaicor/ETSI_support.asp

Copyright Notification

No part may be reproduced except as authorized by written permission.
The copyright and the foregoing restriction extend to reproduction in all media.

© European Telecommunications Standards Institute 2005.
All rights reserved.

DECT™, **PLUGTESTS™** and **UMTS™** are Trade Marks of ETSI registered for the benefit of its Members.
TIPHON™ and the **TIPHON logo** are Trade Marks currently being registered by ETSI for the benefit of its Members.
3GPP™ is a Trade Mark of ETSI registered for the benefit of its Members and of the 3GPP Organizational Partners.

Contents

Intellectual Property Rights	6
Foreword.....	6
0 Introduction	8
0.1 General	8
0.2 Technology features of multipoint systems	9
0.2.1 General.....	9
0.2.2 Network topology overview	9
0.2.3 Multiplexing methods overview	9
0.2.4 Multiple access methods	10
0.2.5 Duplex methods overview	10
0.2.6 Modulation overview.....	10
0.2.7 Error correction overview.....	11
0.2.8 Equivalent Modulation Order (EMO).....	11
0.3 The licensing authority of the national administrations.....	12
1 Scope	13
1.1 Multipoint radio systems	13
1.2 Frequencies.....	13
1.3 Access methods	14
1.4 Equivalent Modulation Order (EMO) and related capacity.....	14
1.5 Duplex methods.....	14
1.6 Asymmetric MP implementations	14
1.7 Antenna types.....	15
1.8 Interoperability requirements	15
2 References	15
3 Definitions, symbols and abbreviations	17
3.1 Definitions.....	17
3.2 Symbols.....	20
3.3 Abbreviations	20
3.4 Equipment classification conventions	22
4 General system architecture	23
4.1 General architecture	23
4.2 Point-to-Multipoint architectures	23
4.3 Mesh (or MP-MP) architectures	24
4.4 Antenna types.....	25
4.5 Antenna type - station type combinations	26
5 Frequency bands and channel plans	26
5.1 Frequency bands.....	26
5.2 Channel arrangements and block assignment.....	28
6 Profiles and requirements.....	29
6.1 Profiles	29
6.1.1 General.....	29
6.1.2 Equipment profiles.....	29
6.1.3 Antenna profiles.....	31
6.1.4 System profiles	31
6.2 RF reference architecture	32
6.3 Environmental Profile	32
6.3.1 General.....	32
6.3.2 Equipment within weather protected locations (indoor locations).....	33
6.3.3 Equipment for non weather protected locations (outdoor locations)	33
6.3.4 Antennas	33
6.4 Main requirements for equipment	33
6.4.1 Introduction.....	33

6.4.2	System capacity	33
6.4.3	Transmit characteristics	34
6.4.4	Receive characteristics.....	34
6.5	Main requirements for antennas	35
7	Complementary requirements	35
7.1	General	35
7.2	System design considerations.....	35
7.2.1	Transmit power tolerance	35
7.2.2	Transmit power range (ATPC/RTPC)	35
7.2.3	Input level range	36
7.2.4	Two tone interference	36
7.2.5	Impulsive interference	36
7.2.6	Distortion sensitivity.....	37
7.2.7	System error performance and availability	37
7.2.8	Residual bit error ratio (RBER)	38
7.2.9	System availability.....	38
7.3	Interfaces	38
7.3.1	Power supply	38
7.3.2	Subscriber interfaces.....	38
7.3.3	Network interfaces	39
7.3.4	Equipment interface to branching network/feeder/antenna	39
7.3.4.1	RF connectors and wave guide flanges	39
7.3.4.2	Return Loss	39
7.3.5	Antenna interface to equipment	40
7.3.5.1	Antenna input connectors.....	40
7.3.5.2	VSWR at the input port(s).....	40
7.3.5.3	Inter-port isolation.....	40
7.4	Environmental and mechanical conditions.....	41
7.4.1	Wind loading and ice loading of antennas	41
7.4.2	Antenna Labelling	41
7.4.3	Mechanical stability.....	41
Annex A (normative):	Equipment Classification (EqC).....	42
A.1	Rationale.....	42
A.2	EqC as a means of identifying a consistent parameter set for equipment compliance.....	42
A.2.1	General	42
A.2.2	Primary Equipment Type (EqC-PET)	43
A.2.3	Secondary Equipment Type (EqC-SET)	43
A.2.4	Equivalent Modulation Order (EqC-EMO).....	44
A.2.5	Channel Separation (EqC-ChS).....	44
A.2.6	Frequency Operating Range (EqC-FR)	45
A.2.7	Station Type (EqC-STN).....	45
Annex B (informative):	Relationship between superseded standards and Equipment Classification (EqC) of equipment profiles.....	46
Annex C (informative):	Receiver selectivity and noise figure	49
Annex D (informative):	Traffic path characteristics.....	50
D.1	Synchronization of traffic interfaces	50
D.2	Round trip delay	50
D.3	Voice coding methods	50
D.4	Transparency	51
Annex E (informative):	Typical reference model for BER, MGBR and EMO.....	52
E.1	General	52

E.2	Interface X ₁ to X _N	53
E.3	Payload processing block	53
E.4	Multiple access block	54
E.5	Outer error correcting block	54
E.6	Inner error correcting block.....	54
E.7	Modulator	55
E.8	Choice of reference point for BER, MGBR and EMO	55
E.9	Examples	55
E.9.1	16 QAM TDMA system with ¾ rate convolutional coding	55
E.9.2	16 QAM TDMA system with ½ rate convolutional coding and 204/188 Reed Solomon coding	56
E.9.3	16 QAM TDMA system with ½ rate turbo coding.....	56
E.9.4	16 QAM FDMA system with ½ rate convolutional coding	56
Annex F (informative): Mixed-mode operation		57
F.1	Introduction	57
F.2	General description of mixed-mode systems	57
F.3	Historical derivation of transmit spectrum masks	57
F.4	Rationale for Multipoint transmit masks.....	58
F.4.1	Introduction	58
F.4.2	Irrelevance of ETSI transmit spectrum mask in determining adjacent channel requirement for intra-system planning	58
F.4.3	Applicability of the transmit spectrum mask to inter-system planning	58
F.4.4	Minimum traffic capacity imposed by the regulator	59
F.5	Essential requirements for transmitters and receivers operating in mixed-mode.....	59
F.5.1	Requirements summary	59
F.5.2	Transmit spectrum masks for mixed-mode	59
F.5.3	Adjacent channel interference	61
F.5.4	Co-channel interference	61
Annex G (informative): Application of this multi-part standard.....		62
Annex H (informative): Notification of Interfaces under article 4.1 of the R&TTE Directive.....		64
H.1	Applicability of TCAM-RIG format of Radio interface specifications to Fixed Services.....	64
H.2	Proposed list of radio interface specifications for Fixed Services.....	65
Annex I (informative): Bibliography.....		66
History		69

Intellectual Property Rights

IPRs essential or potentially essential to the present document may have been declared to ETSI. The information pertaining to these essential IPRs, if any, is publicly available for **ETSI members and non-members**, and can be found in ETSI SR 000 314: "*Intellectual Property Rights (IPRs); Essential, or potentially Essential, IPRs notified to ETSI in respect of ETSI standards*", which is available from the ETSI Secretariat. Latest updates are available on the ETSI Web server (<http://webapp.etsi.org/IPR/home.asp>).

Pursuant to the ETSI IPR Policy, no investigation, including IPR searches, has been carried out by ETSI. No guarantee can be given as to the existence of other IPRs not referenced in ETSI SR 000 314 (or the updates on the ETSI Web server) which are, or may be, or may become, essential to the present document.

Foreword

This European Standard (Telecommunications series) has been produced by ETSI Technical Committee Transmission and Multiplexing (TM).

The present document is part 1 of a multi-part deliverable covering the Fixed Radio Systems; Multipoint Equipment and Antennas, as identified below:

Part 1: "Overview and Requirements for Digital Multipoint Radio Systems";

Part 2: "Harmonized EN covering the essential requirements of article 3.2 of the R&TTE Directive for Digital Multipoint Radio Equipment";

Part 3: "Harmonized EN covering the essential requirements of article 3.2 of the R&TTE Directive for Multipoint Radio Antennas".

This multi-part deliverable covers characteristics and requirements for fixed multipoint radio systems using a variety of multiple access and duplex methods and operating at a variety of bit rates in frequency bands as specified in the present document.

EN 302 326-2 [6] and EN 302 326-3 [7] are Harmonized ENs and essential requirements are those requirements which are essential under article 3.2 of Directive 1999/5/EC of the European Parliament and of the Council of 9 March 1999 on radio equipment and telecommunications terminal equipment and the mutual recognition of their conformity (hereafter mentioned as the R&TTE Directive [1]).

In the above, antennas are both those which are integral to the equipment and those which are non-integral.

Cross references to previous relevant ENs

Up to the publication of the present document, ETSI Digital Multipoint Radio System ENs have been specified in a relatively large number.

Those ENs, to be replaced by this multi-part deliverable, contained both essential requirements, which were cross-referenced in EN 301 753 V1.2 (see bibliography) under the R&TTE Directive [1], and other requirements that may be applicable, even if not considered essential under that Directive.

This multi-part deliverable will replace and supersede, after a suitable transition period the standards that are listed in the three tables below addressing Equipment, Antenna and Harmonized standards respectively. The characteristics of equipment considered in those ENs have also been rationalized, re-compacted and re-subdivided into the various sub parts of this multi-part deliverable.

MP equipment ENs to be superseded

Frequency Range	Nominal Access Method	ETSI Multipoint System Equipment Standard (see bibliography)
< 1 GHz	Common to all	EN 301 460-1
< 1 GHz	TDMA	EN 301 460-2
< 1 GHz	FDMA	EN 301 460-4
< 1 GHz	DS-CDMA	EN 301 460-5
< 1 GHz	FH-CDMA	EN 301 460-3
1 GHz to 3 GHz	TDMA	EN 300 636
1 GHz to 3 GHz	FDMA	EN 301 373
1 GHz to 3 GHz	DS-CDMA	EN 301 055
1 GHz to 3 GHz	FH-CDMA	EN 301 179
3 GHz to 11 GHz	TDMA	EN 301 021
3 GHz to 11 GHz	FDMA	EN 301 080
3 GHz to 11 GHz	DS-CDMA	EN 301 124
3 GHz to 11 GHz	FH-CDMA	EN 301 253
24,25 GHz to 29,5 GHz	Common to all	EN 301 213-1
24,25 GHz to 29,5 GHz	TDMA	EN 301 213-3
24,25 GHz to 29,5 GHz	MC-TDMA	EN 301 213-5
24,25 GHz to 29,5 GHz	FDMA	EN 301 213-2
24,25 GHz to 29,5 GHz	DS-CDMA	EN 301 213-4
31 GHz to 33,4 GHz	Common to all below: TDMA, FDMA, MC-TDMA	EN 302 063: annex A annex B annex C

MP antenna ENs to be superseded

Frequency Range	ETSI Multipoint System Antenna Standard (see bibliography)
1 GHz to 3 GHz	EN 301 525
3 GHz to 11 GHz	EN 302 085
1 GHz to 11 GHz - circularly polarized	EN 302 078
11 GHz to 60 GHz - general aspects	EN 301 215-1
24 GHz to 30 GHz	EN 301 215-2
30 GHz to 40,5 GHz	EN 301 215-4

MP harmonized EN to be superseded

Description	ETSI Multipoint System Harmonized EN (see bibliography)
Generic Harmonized Standard	EN 301 753

The date of cessation of presumption of conformity to Directive 1999/5/EC of the European Parliament and of the Council of 9 March 1999 on radio equipment and telecommunications terminal equipment and the mutual recognition of their conformity (the R&TTE Directive) [1] with reference to EN 301 753 (see bibliography) is proposed to be two years after the date of publication of EN 302 326-2 [6] and EN 302 326-3 [7] in the Official Journal of the European Community.

National transposition dates

Date of adoption of this EN:	16 December 2005
Date of latest announcement of this EN (doa):	31 March 2006
Date of latest publication of new National Standard or endorsement of this EN (dop/e):	30 September 2006
Date of withdrawal of any conflicting National Standard (dow):	30 September 2006

0 Introduction

0.1 General

For the purpose of the present document, multipoint radio systems may be defined as radio systems which interconnect a number of fixed stations (usually more than two). The topology of the systems may be Point-to-Multipoint (P-MP), or multipoint-to-Multipoint (MP-MP), alternatively known as "mesh". A variety of technologies for multiple access and duplex communication is used. The application of these systems is primarily, but not exclusively, to provide access to a variety of services employing a wide range of bit rates. This application is frequently referred to as Fixed Wireless Access (FWA). An alternative application of multipoint radio systems is to provide fixed communication links between stations in a network supporting a different service (such as mobile telephony). This application is frequently known as "infrastructure" or "backhaul". The main field of application of Multipoint (MP) systems using the Fixed Service (FS) is to provide both narrowband and wideband access to both residential and business subscribers to public and private networks (PSTN, Internet, PDN, etc.). By means of MP systems the network service area may cover scattered subscriber locations. The systems may be applied to build new access networks covering urban, suburban and rural areas. Multipoint systems may provide both access and infrastructure applications simultaneously.

Up to the publication of this multi-part deliverable, ETSI Digital Multipoint Radio System ENs have been specified in a relatively large number. There are separate equipment standards for ranges of radio frequencies and access technologies. Similarly, there are separate antenna standards for ranges of radio frequencies. Harmonized European Norm EN 301 753 (see bibliography) identified the essential requirements (in accordance with article 3.2 of the R&TTE Directive [1]) by cross referencing the appropriate sections of the equipment and antenna standards. This multi-part deliverable replaces the current multipoint radio equipment and antenna standards for all frequencies up to 33,4 GHz and the Harmonized EN which defines the essential parameters for these multipoint radio systems. It thereby:

- Presents the characteristics, parameters and requirements for multipoint radio systems in a much more concise form, thus facilitating the distinction between parameters applicable to different Equipment Classifications.
- Removes the extensive cross-referencing in the previous Harmonized EN.
- Facilitates the maintenance of the standard with a far greater degree of uniformity than possible with the current disparate set of standards.
- Facilitates the evolution of the standard in line with the strategy set by the European Commission.
- Rectifies some historical discrepancies in similar requirements appearing in the various MP ENs to be superseded.

This multi-part deliverable is divided as described in clause 1.1.

For systems already covered by the previous EN 301 753 (see bibliography), in general only equal or technically equivalent or less demanding requirements have been used for this multi-part deliverable. Only in a few cases have additional requirements been set or slightly more stringent requirements been imposed, in order to have a more uniform and fair standardized framework across all MP technologies. In all cases, care has been taken that such variations will not affect any frequency planning assumptions for networks already deployed. Therefore, from a strictly technical point of view, in most cases it is expected that equipment already conforming to the previous versions of Harmonized EN 301 753 (see bibliography), would not need re-assessment of essential requirements according to this multi-part deliverable. The legal implications of the declaration of conformity and equipment labelling are, however, outside the scope of this multi-part deliverable. Cases, where additional conformance assessment is required, will be specifically mentioned, where appropriate, in EN 302 326-2 [6] and EN 302 326-3 [7].

In the case of equipment (as opposed to antennas) a specific type of equipment shall be identified by an Equipment Classification (EqC) coherent set, which will specify the principal attributes of the equipment insofar as is necessary to determine which aspects of this multi-part deliverable are applicable. The Equipment Classification is specified in annex A.

Annex G provides guidance to equipment suppliers on how to apply this multi-part deliverable.

0.2 Technology features of multipoint systems

0.2.1 General

There are several mutually independent aspects of technology for Multipoint systems including:

- Network Topology (see clause 0.2.2).
- Multiplexing method (examples are given in clause 0.2.3).
- Multiple access method (examples are given in clause 0.2.4).
- Duplex method (examples are given in clause 0.2.5).
- Modulation method (examples are given in clause 0.2.6).
- Error correcting method (examples are given in clause 0.2.7).

0.2.2 Network topology overview

This multi-part deliverable is concerned mainly with the performance of multipoint equipment and multipoint antennas. However, in practice, a multiplicity of pieces of equipment and connected antennas will work in concert to provide a communication network. The present document considers just two alternative topologies.

- Point-to-Multipoint.
- Multipoint-to-Multipoint (also known as Mesh).

In concept, a **Point-to-multipoint network topology** provides a communication route (on a single radio channel for each sector) from one central point to a number of terminals where users are located. Each user location is either served directly from the central location or via one or more radio repeaters. In general, each user location communicates with the central location by a single pathway.

In concept, a **Multipoint-to-Multipoint (or mesh) network topology** provides communication pathways (sharing a limited number of radio channels) between various system nodes where each node has a communication pathway with a few of its near neighbours. One (or a few) of the nodes might be associated with a core network interface, and many will be at user terminal locations. The communication pathway between core network and user will comprise a number of node-to-node hops. In general there will be multiple alternative routes from user terminal to a core network.

These topologies are discussed more fully in clause 4.

0.2.3 Multiplexing methods overview

A variety of different multiplex methods is used in Point-to-Multipoint (P-MP) systems to multiplex together the signals from a central station (CS) to a number of Terminal Stations (TSs) to allow the radio medium to be shared effectively between the various traffic paths typically under the control of the central station.

Examples of **multiplexing methods** are:

TDM: Time division multiplexing.

FDM: Frequency division multiplexing.

CDM: Code division multiplexing.

OFDM: Orthogonal Frequency Division Multiplexing.

NOTE: OFDM has some attributes of a modulation technique as well as of a multiplexing method.

0.2.4 Multiple access methods

A variety of multiple access methods is used to provide multiple access from a number of TSs to one CS, thus sharing the available radio capacity into the CS between the traffic requirements of the TSs.

Examples of **multiple access methods** are:

- TDMA: Time Division Multiple Access either using a single carrier or multiple carriers; the latter usually identified as Multi Carrier Time Division Multiple Access (MC-TDMA), whose requirements are generally different from the single carrier applications.
- FDMA: Frequency Division Multiple Access.
- DS-SS: Direct Sequence Code Division Multiple Access.
- FH-SS: Frequency Hopping Code Division Multiple Access.
- OFDMA: Orthogonal Frequency Division Multiple Access.

It should be noted that the above list of access methods is historically derived from those defined in the earlier set of multipoint standards. It is not exhaustive and in this respect this multi-part deliverable is, as far as possible, independent of access method. In particular modern digital access technology allows the use of more than one basic access layer (e.g. TDMA/OFDMA).

A description of some of the different basic access methods and a generic comparison among them is provided in TR 101 274 (see bibliography).

Generally, the multiplex method is analogous to the access method. For example, a system using FDMA as the multiple access method from the TSs to CS typically uses Frequency Division Multiplexing (FDM) as the multiplexing method from the CS to the TSs. However, this correspondence is neither universal nor mandatory.

It should be noted that, in general, these different access methods have different values of parameters applicable due to the variation in necessary technical characteristics of such systems.

0.2.5 Duplex methods overview

Two different **duplex methods** are used to separate the two directions of signal in a bi-directional link:

- TDD: Time Division Duplex.
- FDD: Frequency Division Duplex.

NOTE: In FDD operation, two operational modes are possible:

- When both directions transmit simultaneously (generally known as full duplex)
- When the two directions operate at different times (generally known as half duplex, H-FDD).

0.2.6 Modulation overview

In order to transmit digital data across the radio frequency path, one or more parameters of the radio frequency signal is modulated, typically frequency, phase or amplitude. For the commonly used modulation technique, Quadrature Amplitude Modulation (QAM), the two orthogonal carriers are independently amplitude modulated, with the number of discrete amplitude steps permitted for each phase determining the number of possible different states each symbol may assume. In order to constrain the bandwidth of the modulated signal, either the modulating signals or the modulated carriers are filtered (for example, systems may use square root raised cosine shaping of the carrier/sub-carrier). Within a multipoint system different modulation methods may be applied in different situations, at different times and in alternate directions: up-link and down-link.

Examples of **modulation techniques** which may be used in multipoint radio systems are:

- FSK: Frequency Shift Keying.
- PSK: Phase Shift Keying.
- QPSK: Quadrature Phase Shift Keying.
- QAM: Quadrature Amplitude Modulation.
- OFDM: Orthogonal Frequency Division Modulation.

NOTE: OFDM has some attributes of a multiplexing method as well as of a modulation technique.

0.2.7 Error correction overview

The error performance of the system may be improved by the use of **Forward Error Correction (FEC)** or **Automatic ReQuest for retransmission (ARQ)**. One of the main differences between these two techniques stems from their different implementation aspects within an ISO 7 layer model.

Forward error correction may use an inner code (such as convolutional coding), an outer code (such as Reed Solomon), a concatenation of an inner and outer code, or an integrated inner and outer code (such as Turbo code). In general, FEC incurs a constant delay to the data transported and a constant overhead to the available bit rate, although a system may adapt the level of FEC to varying conditions.

ARQ detects the reception of data which are in error and requests retransmission of the faulty data. In general, the delay to the data transmitted may vary, as may the overhead to the available bit rate, although bit error rates approaching zero may be obtained for a wider range of conditions.

A multipoint system may use FEC, ARQ, both, or neither.

0.2.8 Equivalent Modulation Order (EMO)

The modulation order of a modulator and demodulator is determined by the number of discrete states which may be assigned to each symbol. The modulation order is defined as $\log_2(N)$, where N is the number of permitted states per symbol. All other factors being equal, modulation at higher orders is capable of carrying a higher bit rate in the equivalent radio frequency channel when compared with modulation at lower orders, but it can tolerate less interference for the same bit error rate.

However, with the advent of techniques such as forward error correction (as described in clause 0.2.7), the instantaneous bit rate of information which may be transmitted over the air is no longer solely determined by the modulation order. Similarly, the BER performance of a system with FEC is no longer determined solely by the modulation order.

Annex A addresses Equipment Classification (EqC) and defines a new key element in the system profile, Equivalent Modulation Order (EqC-EMO). The supplier indicates a value of EqC-EMO, (which need not necessarily correspond to the physical modulation order) which together with other aspects of EqC, determines which requirements of the standard are applicable to that equipment.

Annex E discusses practical implementation issues concerning the relationship between transmitted bits per second, symbol rate and error correction aspects and considers the reference points at which the minimum gross bit rate and BER may be defined.

Within a multipoint system different modulation orders may be applied in different situations, at different times and in alternate directions up-link and down-link. It should be noted that in P-MP systems CS may use different modulation order (generally higher) than that used in TSs.

0.3 The licensing authority of the national administrations

The sovereign authority of national administrations is, of course, unrestricted by the provisions of this multi-part deliverable and remains outside ETSI's remit.

This multi-part deliverable sets out the requirements for multipoint systems in using alternative topologies, several alternative frequency band and channel plans, using alternative duplex methods, using different equipment types and different antenna types. However, attention is drawn to the fact that many aspects of the equipment and antennas addressed by this multi-part deliverable will be subject to national licensing rules. For instance, the national licensing authorities might restrict the deployment and operation of equipment and antennas compliant with this multi-part deliverable, as an example in terms of:

- Network topology.
- Operating radio frequency bands and block and/or channel arrangements.
- EqCs permitted (for the purpose of "effective use of spectrum" according to the R&TTE Directive).
- Duplex method and, in the case of FDD, duplex separation and sense.
- Antenna gain, permitted classes and polarization.

Several frequency bands are explicitly listed in clause 5 of the present document as identified by CEPT for multipoint systems. However, multipoint systems may be licensed on a national basis for use in other bands currently assigned by CEPT to Fixed Service (see ERC Report 25 (see bibliography)) or in other bands within the frequency ranges as permitted by national administrations. The present document may be applied to any bands, or parts of bands, within the frequency ranges covered by the scope of the present document (see clause 1.2), pending national administration or future CEPT regulation. However, it is intended that this multi-part deliverable shall be applied only to frequency bands which are co-ordinated, whether such co-ordination is on a national or CEPT basis.

1 Scope

1.1 Multipoint radio systems

This multi-part deliverable is applicable to fixed digital multipoint (MP) radio systems, where multipoint encompasses both point-to-multipoint (P-MP) and multipoint-to-multipoint (MP-MP) network architectures. (Although MP-MP systems may, in principle, be realized using directional or sectorial/omnidirectional antennas, only those using directional antennas are within the scope of this multi-part deliverable).

The applicability of this multi-part deliverable to MP equipment is governed by the definition of a number of system profiles that define the set of consistent requirements (see clause 6) to which equipment shall conform. The supplier shall uniquely identify in the technical construction file which Equipment Classification(s) (EqC) (among those limited sets defined in clause 6 and annex A) apply to his equipment and assess it consequently.

The individual parts of this multi-part deliverable are applicable as follows:

The present document includes for multipoint radio systems (equipment and antennas, whether integrated or not):

- Descriptions and parameters of the characteristics of multipoint radio systems.
- Cross-references to EN 302 326-2 [6] and EN 302 326-3 [7] where limits for essential parameters for conformance with article 3.2 of the R&TTE Directive are concerned.
- Specifications which may be complied with on a voluntary basis (normative).
- Recommended limits for other parameters (informative).
- Informative text which assists in the understanding of the specification.

EN 302 326-2 [6] includes for multipoint radio equipment (whether or not integrated with an antenna):

- Essential requirements for conformance with article 3.2 of the R&TTE Directive.

EN 302 326-3 [7] includes for antennas used with multipoint radio systems (whether or not integrated with the equipment):

- Essential requirements for conformance with article 3.2 of the R&TTE Directive.

For Administration's guidance when notifying their regulated Interfaces in accordance with article 4.1 of the R&TTE Directive [1], annex B provides explanatory considerations on the applicability of the TCAM-RIG format for P-P Fixed Links. An example of such a notification is also provided. Annex H has been elaborated in co-ordination with the CEPT ECC WG SE.

1.2 Frequencies

This multi-part deliverable is applicable to multipoint radio equipment and antennas operating in bands allocated to Fixed Service and assigned by national regulations to MP applications, at the date of publication of this EN, within the following frequency ranges:

- Equipment:
 - 30 MHz to 11 GHz.
 - 24,25 GHz to 29,5 GHz.
 - 31,0 GHz to 33,4 GHz.

NOTE 1: Equipment operating in the band from 40,5 GHz to 43,5 GHz is not covered by the present document, but is to be found in EN 301 997-1 and EN 301 997-2 (see bibliography).

- Antennas:
 - 1 GHz to 3 GHz.
 - 3 GHz to 11 GHz.
 - 24,25 GHz to 40,5 GHz.

NOTE 2: Antennas operating in the band from 40,5 GHz to 43,5 GHz are not covered by the present document, they are found in EN 301 215-3 and EN 301 997-2 (see bibliography).

Antenna characteristics are not specified at frequencies below 1,0 GHz. Therefore, for either non-integral antennas below this limit or for equipment with integral antennas below this limit, the Harmonized EN 302 326-2 [6] and EN 302 326-3 [7] are not sufficient for the Declaration of Conformity, according to article 3.2 of the R&TTE Directive [1], and additional essential test suites for antenna requirements shall be agreed with the Notified Body.

1.3 Access methods

The scope of this multi-part deliverable places no restriction on access method (or combinations of access methods) used. The standard applies to certain equipment profiles defined in terms of Equipment Classification (EqC) and listed in clause 6.1. One field of EqC is Primary Equipment Type (EqC-PET), which although historically related to specific access methods places no restriction on access method used provided all requirements for the profile are met. The relationship between the former explicit access methods and the EqC-PET values is shown in informative annex B.

In general, requirements traditionally related to access method are related to EqC-PET. Exceptionally, some non-essential requirements depend upon the actual access method being used (e.g. where access methods using frequency hopping techniques are used there is a restriction on the hopping period).

1.4 Equivalent Modulation Order (EMO) and related capacity

The R&TTE Directive [1] recognizes that mandatory requirements may apply in order to use the spectrum effectively. A large number of factors contribute to the spectral efficiency of a deployed system, but two key parameters have historically been recognized and specified: Minimum Gross Bit Rate (MGBR) and modulation order. Historically, FDMA systems have specified the payload data rate in place of the MGBR, while others have specified the MGBR as the instantaneous bit rate applied to the modulator when user data are being carried. These issues are discussed in annex E.

1.5 Duplex methods

The present document is equally applicable to multipoint systems which use Time Division Duplexing (TDD) or Frequency Division Duplexing (FDD or H-FDD).

NOTE: Attention is also drawn to general guidance given within CEPT Recommendations and others to assigning spectrum so as to allow different systems to operate in adjacent assigned frequencies without unacceptable mutual interference. This is outside the scope of the present document but it is responsibility of the regulatory authorities. For this purpose CEPT Recommendations and Reports offer guidelines particularly in reference to the use of spectrum where different duplex methods are to be used. This includes advice, for systems using FDD, identifying which sub-band is to be used for upstream-links and which for downstream-links for easing the coexistence between neighbouring systems.

1.6 Asymmetric MP implementations

In general, P-MP systems will use corresponding multiplexing methods and multiple access methods in both CS-transmit and CS-receive directions, but nothing prevents dissimilar methods being applied in the alternate directions. Likewise, different radio characteristics (such as different modulation methods, different modulation orders) may be employed in the alternate directions, potentially resulting in asymmetrical capacities and performance. Furthermore, some systems may be designed to operate with different channel separations in up- and down-link directions.

NOTE 1: Implementations, such as in some FDMA systems, where some TS may use a subset of the channels assigned to the CS are not regarded as asymmetric MP implementations from the point of view of the channel separation.

In all asymmetric cases, the provisions of this multi-part deliverable shall apply independently to the transmit and receive directions of a given equipment.

NOTE 2: The deployment of asymmetric systems should take into account the licensing conditions of national administrations.

1.7 Antenna types

This multi-part deliverable specifies several antenna types appropriate for multipoint systems according to their radio frequencies, radiation patterns and polarization. Such antennas may be integral or non-integral.

- Bands of radio frequencies addressed are:
 - 1 GHz to 3 GHz;
 - 3 GHz to 11 GHz;
 - 24,25 GHz to 40,5 GHz.
- Radiation pattern types addressed are: Directional, Sectored (both single beam and multi beam) and Omnidirectional.
- Polarization types addressed are: linear and circular, in orthogonal orientations.

The defined set of antennas does not include all combinations of the above attributes: the comprehensive list is further defined in clause 6.1.3. This multi-part deliverable is equally applicable to integral and non-integral antennas.

Not every antenna type may be coupled with every station type. Only the cases provided in clause 6.1.4 are in the scope of the present document.

1.8 Interoperability requirements

This multi-part deliverable does not set any requirements for interoperability between CSs, RSs and TSs from different manufacturers and no requirement or capability for such interoperability is either stated or implied.

2 References

The following documents contain provisions which, through reference in this text, constitute provisions of the present document.

- References are either specific (identified by date of publication and/or edition number or version number) or non-specific.
- For a specific reference, subsequent revisions do not apply.
- For a non-specific reference, the latest version applies.

Referenced documents which are not found to be publicly available in the expected location might be found at <http://docbox.etsi.org/Reference>.

- [1] Directive 1999/5/EC of the European Parliament and of the Council of 9 March 1999 on radio equipment and telecommunications terminal equipment and the mutual recognition of their conformity (R&TTE Directive).
- [2] ETSI ETS 300 132-1: "Equipment Engineering (EE); Power supply interface at the input to telecommunications equipment; Part 1: Operated by alternating current (ac) derived from direct current (dc) sources".

- [3] ETSI EN 302 217-2-1: "Fixed Radio Systems; Characteristics and requirements for point-to-point equipment and antennas; Part 2-1: System-dependent requirements for digital systems operating in frequency co-ordination is applied".
- [4] ETSI EN 302 217-4-1: "Fixed Radio Systems; Characteristics and requirements for point-to-point equipment and antennas; Part 4-1: System-dependent requirements for antennas".
- [5] ETSI EN 302 217-4-2: "Fixed Radio Systems; Characteristics and requirements for point-to-point equipment and antennas; Part 4-2: Harmonized EN covering essential requirements of Article 3.2 of R&TTE Directive for antennas".
- [6] ETSI EN 302 326-2: "Fixed Radio Systems; Multipoint Equipment and Antennas; Part 2: Harmonized EN covering the essential requirements of Article 3.2 of the R&TTE Directive for Digital Multipoint Radio Equipment".
- [7] ETSI EN 302 326-3: "Fixed Radio Systems; Multipoint Equipment and Antennas; Part 3: Harmonized EN covering the essential requirements of Article 3.2 of the R&TTE Directive for Multipoint Radio Antennas".
- [8] ETSI EN 300 019 (all parts): "Environmental Engineering (EE); Environmental conditions and environmental tests for telecommunications equipment".
- [9] ETSI EN 300 019-1-4: "Environmental Engineering (EE); Environmental conditions and environmental tests for telecommunications equipment; Part 1-4: Classification of environmental conditions; Stationary use at non-weatherprotected locations".
- [10] IEC 60154-1: "Flanges for waveguides. Part 1: General requirements".
- [11] IEC 60154-2: "Flanges for waveguides. Part 2: Relevant specifications for flanges for ordinary rectangular waveguides".
- [12] IEEE 802.3: "Information technology - Telecommunications and information exchange between systems - Local and metropolitan area networks - Specific requirements - Part 3: Carrier Sense Multiple Access with Collision Detection (CSMA/CD) Access Method and Physical Layer Specifications".
- [13] ISO/IEC 8802-3: "Information technology - Telecommunications and information exchange between systems - Local and metropolitan area networks - Specific requirements - Part 3: Carrier sense multiple access with collision detection (CSMA/CD) access method and physical layer specifications".
- [14] ITU-R Recommendation F.557: "Availability objective for radio-relay systems over a hypothetical reference circuit and a hypothetical reference digital path".
- [15] ITU-R Recommendation F.634: "Error performance objectives for real digital radio-relay links forming part of the high-grade portion of international digital connections at a bit rate below the primary rate within an integrated services digital network".
- [16] ITU-R Recommendation F.695: "Availability objectives for real digital radio-relay links forming part of a high-grade circuit within an integrated services digital network".
- [17] ITU-R Recommendation F.696: "Error performance and availability objectives for hypothetical reference digital sections forming part or all of the medium-grade portion of an ISDN connection at a bit rate below the primary rate utilizing digital radio-relay systems".
- [18] ITU-R Recommendation F.697: "Error performance and availability objectives for the local-grade portion at each end of an ISDN connection at a bit rate below the primary rate utilizing digital radio-relay systems".
- [19] ITU-R Recommendation F.746: "Radio-frequency arrangements for fixed service systems".
- [20] ITU-R Recommendation F.752: "Diversity techniques for radio-relay systems".
- [21] ITU-R Recommendation F.1093: "Effects of multipath propagation on the design and operation of line-of-sight digital radio-relay systems".

- [22] ITU-R Recommendation F.1101: "Characteristics of digital fixed wireless systems below about 17 GHz".
- [23] ITU-R Recommendation F.1102: "Characteristics of fixed wireless systems operating in frequency bands above about 17 GHz".
- [24] ITU-R Recommendation F.1492: "Availability objectives for real digital radio-relay links forming part of international portion constant bit rate digital path at or above the primary rate".
- [25] ITU-R Recommendation F.1493: "Availability objectives for real digital radio-relay links forming part of national portion constant bit rate digital path at or above the primary rate".
- [26] ITU-R Recommendation F.1668: "Error performance objectives for real digital fixed wireless links used in 27 500 km hypothetical reference paths and connections".
- [27] ITU-R Recommendation P.530: "Propagation data and prediction methods required for the design of terrestrial line-of-sight systems".
- [28] ITU-T Recommendation G.821: "Error performance of an international digital connection operating at a bit rate below the primary rate and forming part of an Integrated Services Digital Network".
- [29] ITU-T Recommendation G.826: "End-to-end error performance parameters and objectives for international, constant bit-rate digital paths and connections".
- [30] ITU-T Recommendation G.827: "Availability performance parameters and objectives for end-to-end international constant bit-rate digital paths".
- [31] ITU-T Recommendation G.828: "Error performance parameters and objectives for international, constant bit rate synchronous digital paths".
- [32] ITU-T Recommendation I.356: "B-ISDN ATM layer cell transfer performance".
- [33] ITU-T Recommendation I.357: "B-ISDN semi-permanent connection availability".
- [34] ITU-T Recommendation Y.1540: "Internet protocol data communication service - IP packet transfer and availability performance parameters".
- [35] ITU-T Recommendation Y.1541: "Network performance objectives for IP-based services".

3 Definitions, symbols and abbreviations

3.1 Definitions

For the purposes of the present document, the following terms and definitions apply:

Channel Separation (ChS): separation between the centre frequencies of neighbouring RF channels according ITU-R Recommendation F.746 and used for adjacent channel interference requirements

NOTE 1: In cases where the RF channel is not clearly defined, or (particularly for FH-CDMA systems) where the channel separation is less than the manufacturer's declared sub-channel bandwidth. In some access methodologies the whole channel given to the system is subdivided in sub-channels for use by subsets of terminal stations; however also in this case the channel separation is still defined intended in the same way as the above definition (minimum continuous segment of bandwidth made available to the system).

NOTE 2: In this multi-part deliverable Channel Separation (ChS) is a free variable the value(s) of which the supplier shall declare. Limiting values of some other parameters which are requirements of EN 302 326-2 [6] are expressed as functions of ChS. CEPT Recommendations and national administrations may replace restrictions on which ChS values are permitted.

chip: unit of modulation used in Direct Sequence Code Division Multiple Access (DS-SS) expressed as the number of chips per second

chip sequence: sequence of chips with defined length and chip polarities

Direct Sequence Spread Spectrum (DSSS): scheme where the data to be transmitted is combined with a fixed code sequence (chip sequence)

NOTE: This can be used to modulate a carrier.

Direct Sequence Spread Spectrum modulation: form of modulation whereby a combination of data to be transmitted and a fixed code sequence (chip sequence) is used to directly modulate a carrier, e.g. by phase shift keying

DS-CDMA Full Capacity Load: maximum number of 64 kbit/s signals or equivalent which can be transmitted and received by a single CS within a specified RF-bandwidth, fulfilling given performance and availability objectives in respect to fading conditions

DS-CDMA maximum system loading: maximum possible payload data rate on a single RF channel for the class of operation declared by the manufacturer

single DS-CDMA signal: single traffic channel and any associated signalling and synchronization overhead

Equipment Classification (EqC): multi-field classification which indicates the principal characteristics of a particular equipment within the scope of EN 302 326 and indicates which alternative consistent sets of requirements of EN 302 326 apply to that equipment

NOTE: See annex A which addresses the EqC concept.

Frequency Hopping (FH): spread spectrum technique whereby individual radio links are continually switched from one sub-channel to another

NOTE: Such links are not constrained to a single RF channel.

FH-CDMA dwell time: duration of a transmission on a particular sub-channel

FH-CDMA assigned band: aggregation of all RF channels assigned to a FH-CDMA system

NOTE: The assigned band may consist of several non-contiguous RF channels (see figure 1).

FH-CDMA sub-channel: integer sub-division of the RF channel(s) as determined by the equipment manufacturer (see figure 1)

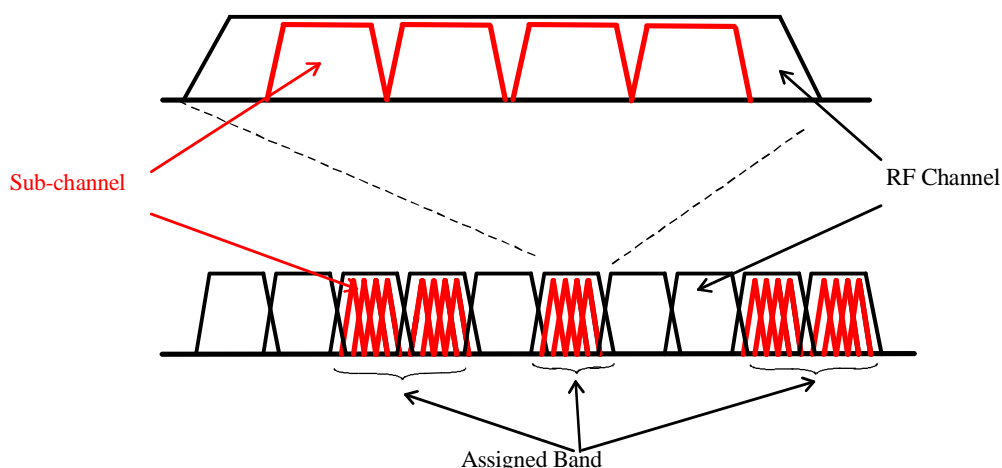

Figure 1: Relationship between "sub-channel", "RF channel" and "assigned band"

FH-hopping period: time between the starts of successive transmissions on a different sub-channel

NOTE: This is the sum of dwell time and transition time.

FH-slow frequency hopping: FH technique where the hopping period is larger than the symbol period

FH-hopping sequence: sequence of sub-channels which a particular link follows

FH-CDMA transition time: period between successive transmissions on different sub-channels during which no transmission is made

gross bit rate: transmission bit rate over the air

NOTE: In case of a transmitter working in burst mode the gross bit rate is the instantaneous maximum transmission bit rate during the burst. The gross bit rate has a unique relationship to the symbol rate through the implemented modulation format. In the case of OFDMA this relationship is unique when all OFDMA sub carriers are in use. Gross bit rate for TDMA/OFDMA systems is the aggregate bit rate of all OFDMA sub carriers transmitting simultaneously; (e.g. for a TDMA/OFDMA system, in any single TDMA burst any single OFDMA TS may be dynamically assigned a subset of the OFDMA-sub-channels. Multiple TS are allowed to transmit at the same time on disjoint sets of OFDM-sub-carriers, so the MGBR is defined when all available OFDM-sub-carriers are in use at the same time.)

integral antenna: antenna which is declared to be part of the radio equipment by the supplier

NOTE: Even when equipment with an integral antenna is concerned, it might still be possible to separate the antenna from the equipment using a special tool. In such cases the assessment of the radio equipment and of the antenna against requirements of this multi-part deliverable may be done separately.

mixed-mode system: system having the capability for stations (CS or TS or RS) to operate on different modulation orders and/or switch dynamically between different modulation orders

NOTE: This capability may be used to improve deployment and capacity capabilities or to adaptively adjust for varying channel impairments, or to improve spectral efficiency by dynamically allocating transmission capacity. The switching between modulation orders may occur as frequently as appropriate to the system, (e.g. on a per-burst or per-timeslot or per-carrier basis). See also: single-mode systems and preset-mode systems.

multi-carrier system: system where more than one modulated sub-carrier is radiated from the same transmitter

NOTE 1: A system that uses several transmitters into a non-active antenna is not considered as a multi-carrier system. Systems using FDM/OFDM modulation formats are also not considered multi-carrier unless more than one separate FDM/OFDM signal set is transmitted from the same transmitter.

NOTE 2: FDMA systems are intrinsically multicarrier, because any single sub-carrier may be easily discriminated at RF level (unlike OFDM modulations) and activated according to the traffic requirements. However, for the purpose of the present document, a FDMA system are also considered as a whole (fully loaded) single signal set, unless more than one FDMA signal set is transmitted from the same transmitter.

nominal output power: maximum output power of the CS, Terminal Station (TS) or Repeater Station (RS) referred to point C' (figure 5) under Full Load Condition, as declared by the manufacturer

Orthogonal Frequency Division Multiplexing (OFDM): multiplexing method where the transmitted signal is composed of multiple narrow band OFDM-sub-carriers, all modulated in parallel

Orthogonal Frequency Division Multiple Access (OFDMA): access method related to the OFDM multiplexing method where only a subset of the OFDM-sub-carriers are used by any single transmitter, allowing multiple transmitters to transmit at the same time on disjoint sets of OFDM-sub-carriers

NOTE: When used in conjunction with TDMA this applies burst by burst.

OFDM-sub-carrier: physical sub-division of the channel as determined by the manufacturer for OFDM and OFDMA systems

NOTE: The complete set of discrete sub-carriers is distributed throughout the assigned channel. With OFDM (and OFDMA), individual symbols are represented by all (or some) of the sub-carriers operating in concert rather than by individual sub-carriers.

OFDMA-sub-channel: logical channel for transmission or control purposes, comprising a set of physical OFDM sub-carriers

NOTE: The specific sub-carriers associated with a particular sub-channel are usually dynamically distributed throughout the whole channel bandwidth. The minimum number of sub-carriers that may comprise a sub-channel is dependent on the system design.

offset channel: radio channel at a frequency other than co-channel but closer than half the adjacent channel separation

preset-mode (multi-format) system: system that can be statically configured or preset to operate on a permanent basis with one among several possible modulation orders

NOTE: Signals transmitted from any station use the single modulation order which has been preset. The presetting could be fixed, or if the licence permits, may be changed from time to time according to the operator's needs. (see also: single-mode system and mixed-mode system).

Radio Frequency channel (RF channel): partition of a radio frequency band which may be assigned by the authorities in accordance with CEPT, ITU-R Recommendations or national authorities regulations on channel arrangement

round trip delay: sum of the delay between the Core Network Interfaces and the Terminal Interfaces in figures 2 and 3 and the delay in the reverse direction between the same points

single-mode system: system designed to operate with a single modulation order only

NOTE: See also preset-mode system and mixed-mode system.

system loading: total payload data rate on a single RF channel

3.2 Symbols

For the purposes of the present document, the following symbols apply:

dB	deciBel
dBm	deciBel relative to 1 milliwatt
f_0	Centre of a radio frequency channel
GHz	GigaHertz
Hz	Hertz
kbit/s	kilobits per second
kHz	kiloHertz
km	kilometre
Mbit/s	Megabits per second
MHz	MegaHertz
ms	millisecond
mW	milliwatt
ns	nanosecond
Ω	ohm
s	second
V	volt

3.3 Abbreviations

For the purposes of the present document, the following abbreviations apply:

AC	Alternating Current
ADPCM	Adaptive Differential Pulse Code Modulation
ARQ	Automatic ReQuest for retransmission
ATM	Asynchronous Transfer Mode
ATPC	Automatic Transmit Power Control
BER	Bit Error Ratio
CDMA	Code Division Multiple Access
CENELEC	Comité Européen de Normalisation ELECtrotechnique

CEPT	Conférence des Administrations Européennes des Postes et Télécommunications
ChS	Channel Separation
CORDIS	COmmunity Research and Development Information Service
COST	European Cooperation in the field of Scientific and Technical research
CS	Central Station
CS-ACELP	Conjugate Structure Algebraic-Code-Excited Linear-Prediction
CSMA/CD	Carrier Sense Multiple Access with Collision Detection
CW	Continuous Wave
DC	Direct Current
DLC	Data Link Control
DQPSK	Differential Phase Shift Keying
DS-CDMA	Direct Sequence - Code Division Multiple Access
ECC	Electronic Communications Committee
EG	ETSI Guide
EIRP	Equivalent Isotropically Radiated Power
EMC	ElectroMagnetic Compatibility
EMO	Equivalent Modulation Order
EN	European Norm
EqC	Equipment Classification

NOTE: See annex A.

ERC	European Radiocommunications Committee
ETS	European Telecommunication Standard
ETSI	European Telecommunications Standards Institute
FDD	Frequency Division Duplex
FDM	Frequency Division Multiplexing
FDMA	Frequency Division Multiple Access
FEC	Forward Error Correction
FH	Frequency Hopping
FH-CDMA	Frequency Hopping - Code Division Multiple Access
FS	Fixed Service
FSK	Frequency Shift Keying
FWA	Fixed Wireless Access
GMSK	Gaussian Minimum Shift Key
IEC	International Electrotechnical Commission
IPR	Intellectual Property Rights
ISO	International Standards Organization
ISDN	Integrated Services Digital Network
ITU	International Telecommunications Union
MC-TDMA	Multiple Carrier - Time Division Multiple Access
MGBR	Minimum Gross Bit Rate
MIB	Management Information Block
MOS	Mean Opinion Score
MP	MultiPoint

NOTE: Generic term for P-MP and MP-MP.

MP-MP	MultiPoint-to-MultiPoint
NFD	Net Filter Discrimination
NNI	Network Node Interface
OFDM	Orthogonal Frequency Division Multiplexing
OFDMA	Orthogonal Frequency Division Multiple Access
PDH	Plesiochronous Digital Hierarchy
PDN	Private Data Network
P-MP	Point-to-MultiPoint
PP	Point-to-Point
PSK	Phase Shift Keying
PSTN	Public Switched Telephone Network
QAM	Quadrature Amplitude Modulation
QDU	Quantization Distortion Unit
QPSK	Quadrature Phase Shift Keying
R&TTE	Radio and Telecommunications Terminal Equipment

RBBER	Residual BER
RF	Radio Frequency
RFC	Remote Frequency Control
RPE	Radiation Performance Envelope
RS	Repeater Station
RSL	Receiver Signal Level
RTPC	Remote Transmit Power Control
SDH	Synchronous Digital Hierarchy
SNI	Service Node Interface (see EG 202 306)
SNMP	Simple Network Management Protocol
TCAM-RIG	Telecommunication Conformity Assessment and Market Surveillance Committee - Radio Interface Group
TDD	Time Division Duplex
TDMA	Time Division Multiple Access
TDMA/OFDMA	Time Division Multiple Access used in combination with Orthogonal Frequency Division Multiple Access
TE	Terminal Equipment
TM	Transmission and Multiplex
TS	Terminal Station
UNI	User Network Interface (see EG 202 306)
VSWR	Voltage Standing Wave Ratio
WGSE	Working Group Spectrum Engineering
WLL	Wireless Local Loop

3.4 Equipment classification conventions

For the purposes of the present document, the following equipment classification conventions apply:

NOTE: See annexes A and B.

D	A value of EqC-PET, historically related to DS-CDMA equipment
DM	A EqC-SET code, historically associated with OFDM modulation
DQ	A EqC-SET code, historically associated with DQPSK modulation
EqC-ChS	Channel Separation field of the EqC
EqC-EMO	Equivalent Modulation Order field of the EqC
EqC-FR	Frequency Range field of the EqC
EqC-PET	Primary Equipment Type field of the EqC
EqC-SET	Secondary Equipment Type field of the EqC
EqC-STN	Type of Station field of the EqC
F	A value of EqC-PET, historically related to FDMA equipment
FA	A EqC-SET code, historically associated with Type A FDMA equipment
FB	A EqC-SET code, historically associated with Type B FDMA equipment
GM	A EqC-SET code, historically associated with GMSK modulation
H	A value of EqC-PET, historically related to FH-CDMA equipment
HC	A EqC-SET code, historically associated with High Compatibility
LC	A EqC-SET code, historically associated with Low Complexity
M	A value of EqC-PET, historically related to MC-TDMA equipment
MA	A EqC-SET code, historically associated with TDMA/OFDMA equipment
O	A value of EqC-PET, historically related to TDMA-OFDMA equipment
OR	A EqC-SET code, historically associated with Orthogonal coding DS-CDMA equipment
PR	A EqC-SET code, historically associated with Pseudo Random coding DS-CDMA equipment
QP	A EqC-SET code, historically associated with QPSK modulation
T	A value of EqC-PET, historically related to TDMA equipment

4 General system architecture

4.1 General architecture

Multipoint fixed wireless systems are characterized by systems architectures in which a number of stations are interconnected by radio to deliver services from one or more core network connection points to connections to terminal equipment.

Architectures currently covered by the present document are:

- Point-to-Multipoint (P-MP).
- Mesh (or Multipoint-to-Multipoint).

The next two clauses describe these architectures and figures 2 and 3 show representative examples of such systems.

4.2 Point-to-Multipoint architectures

In a Point-to-Multipoint system, a Central Station communicates with Terminal Stations, occasionally via Repeater Stations, and exceptionally via further cascaded Repeater Stations. In the example of figure 2, the Central Station operates using a sectored or omni directional antenna in a Point-to-Multipoint configuration, serving three Terminal Stations directly and two via a Repeater Station.

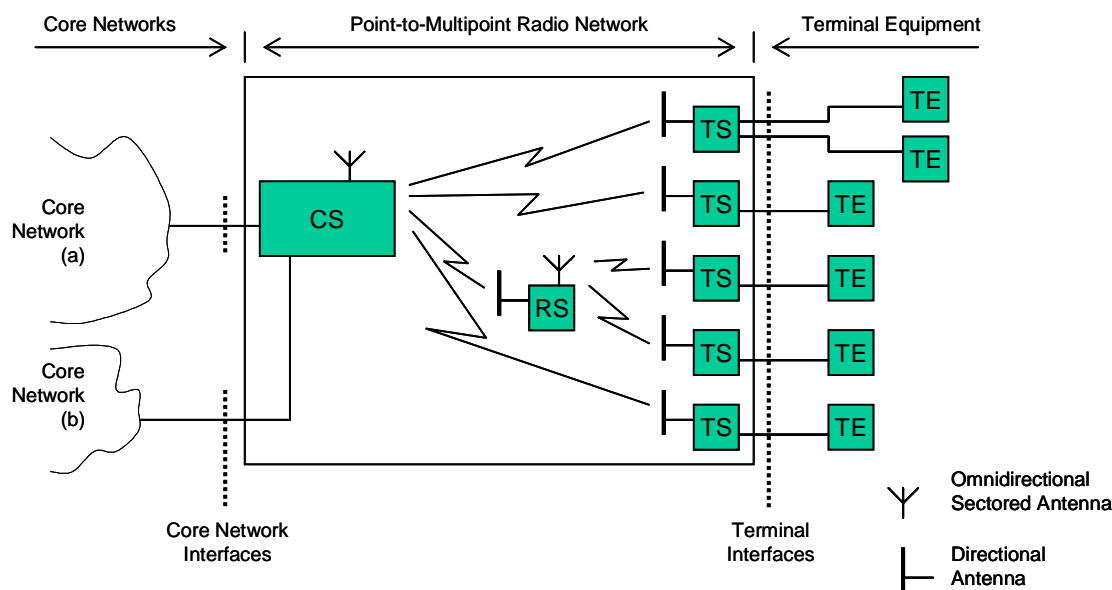

Figure 2: Representative example of a Point-to-Multipoint radio network

Where:

CS is a Central Station, which interfaces to the core network.

TE is Terminal Equipment.

TS is a Terminal Station which interfaces to one or more Terminal Equipment units.

RS is a Repeater Station which provides a radio repeater outstation function.

Any specific equipment in a Point-to-Multipoint system within the scope of the present document shall be a CS, a TS or a RS. The station type (EqC-STN) for particular equipment is one of the key components the Equipment Identification Code of that equipment which determines which parts of the standard apply to that equipment. Annex A addresses EqC.

The Central Station may, in addition to its function as an interface to the core network, perform a control function in the system (such as the allocation of radio system capacity on a demand basis in a concentrated system). The CS may be distributed between locations interconnected by digital transmission links (For example: with one part collocated with a central exchange whilst another part (or parts) located where convenient for radio coverage).

In a Point-to-Multipoint system, the Repeater Station acts simply to relay a signal received from a Central Station to Terminal Stations and further Repeater Stations and, similarly, to relay the signal received from Terminal Stations and Repeater Stations back to the Central Station. This mode of operation allows the Repeater Station, which may serve one or more terminals, to fill in areas that would otherwise be in radio shadow from physical obstructions. The Repeater Stations under the scope of this multi-part deliverable will utilize a directional antenna facing the Central Station or "upstream" Repeater Station and a directional, sectored or omni directional antenna facing the Terminal Stations or "downstream" Repeater Station(s).

A Terminal Station communicates with either a single Central Station or a single Repeater Station; Terminal Stations under the scope of this multi-part deliverable will use a directional antenna.

When a multipoint radio system is deployed in the access telephony network, it may be appropriate to connect the CS to a local exchange, in which case the Core Network Interface (see figure 2) interface between the CS and the local exchange forms the SNI (Service Node Interface), as described, for instance, in EG 202 306 (see bibliography). Alternatively, where the CS incorporates local exchange functionality (e.g. the CS may incorporate an ATM switch interfacing into an ATM network), it may be appropriate to connect the CS directly to a trunk or international exchange, in which case the interface between the CS and the exchange forms the NNI (Network Node Interface). In either case, the Terminal Interface (see figure 2) between the RS or TS and the Terminal Equipment forms the UNI (User Network Interface), as described, for instance, in EG 202 306 (see bibliography). Analogous options apply when the radio system provides access functionality for IP services.

When broadcast or private networks are concerned, different interfaces are also possible. For private networks, the interfaces to Terminal Equipment may also be custom interfaces.

In the case where the multipoint radio system provides backhaul facilities for a different service, e.g. for mobile base stations interconnections), the function of the multipoint system will usually be to provide a "bit pipe" between remote nodes (equivalent to Terminal Equipment on the diagram) and core network nodes.

It should also be noted that Central Stations may not be co-located with core network nodes and the connection between the two may be effected by radio links, optical fibre links, or other means.

Subscriber to subscriber connections may also be provided in some networks, not routed via an external core network. In this case, connections between Central Stations may exist which are effected by radio links, optical fibre links, or other means.

4.3 Mesh (or MP-MP) architectures

In Mesh architectures within the scope of this multi-part deliverable, Stations are connected as an adaptable network, using individual station to station links. In this case, the network may be designed such that there are multiple paths to each Station. In figure 3, seven Repeater Stations operate as a mesh network communicating via directional antennas and interfacing to Terminal Equipment and Core Networks.

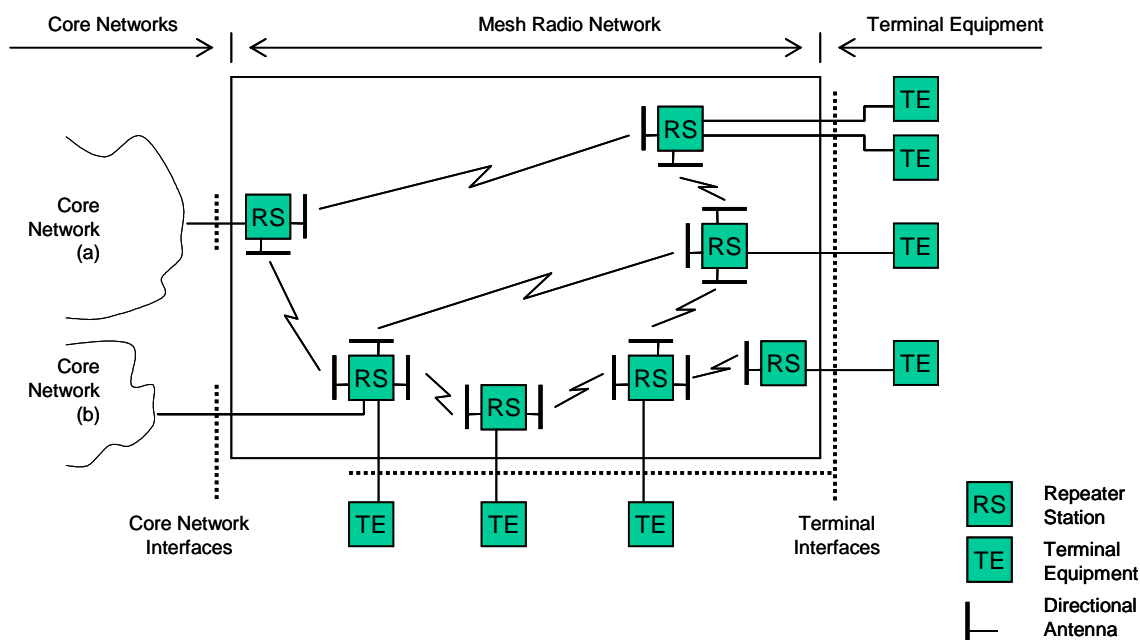

Figure 3: Representative example of a Mesh radio network using directional antennas

Where:

TE is Terminal Equipment.

RS is a Repeater Station which provides a radio repeater outstation function and usually interfaces to one or more Terminal Equipment units and/or one or more Core Networks. All stations in a mesh system within the scope of the present document are RSs. Such stations use directional antennas only.

Any specific equipment in a Mesh system that is within the scope of the present document shall be a RS. The station type (EqC-STN) for a particular equipment is one of the key components the Equipment Classification of that equipment which determines which parts of the standard apply to that equipment. Annex A addresses EqC.

In addition to the radio repeating function for which the Repeater Station is used in Point-to-Multipoint systems, it may additionally terminate or route traffic. In a mesh network, it therefore acts as a node in the network and transmits traffic on the optimum link to reach its required destination or presents the traffic directly to the Terminal Equipment and/or Core Network if appropriate. In a mesh application, the Repeater Station will utilize a directional antenna for each link with another station.

4.4 Antenna types

Antennas, either integral or non-integral, of the various radiation pattern types intended for use in multipoint systems described in the previous clauses are specified in EN 302 326-2 [6] and EN 302 326-3 [7]. The types are summarized in table 1.

Table 1: Multipoint antenna types and their application

Type	Intended application	Notes
Directional	Where the purpose of the antenna is to link with a single other station	
Sectored (single and multi-beam)	Where the purpose of the antenna is to link with several other stations	Sectored antennas with beamwidth < 15° shall conform to the specification otherwise applicable to a directional antenna. Single beam antennas are designed to radiate and receive over a defined angular sector in the azimuth plane as declared by the manufacturer. Multi-beam antennas are designed to radiate and receive over several defined angular sectors in the azimuth plane as declared by the manufacturer
Omnidirectional		Omnidirectional antennas are designed to radiate and receive over the full 360° in the azimuth plane.

Multipoint antennas shall conform with the requirements of the present document and EN 302 326-3 [7], except for links to Terminal Stations with longer hop lengths, where the antenna may alternatively comply with EN 302 217-4-2 [5] or with annex A of EN 302 217-4-1 [4].

4.5 Antenna type - station type combinations

This multi-part deliverable applies only to multipoint systems using certain antenna and station type combinations according to whether the network topology is P-MP or MP-MP (Mesh). Clause 6.1.4 defines which combinations are within the scope of this multi-part deliverable.

5 Frequency bands and channel plans

5.1 Frequency bands

The applicable frequency ranges for multipoint equipment covered by this multi-part deliverable are:

- 30 MHz to 1 GHz.
- 1 GHz to 3 GHz.
- 3 GHz to 11 GHz.
- 24,25 GHz to 29,5 GHz.
- 31,0 GHz to 33,4 GHz.

The applicable frequency ranges for multipoint antennas covered by this multi-part deliverable are:

- 1 GHz to 3 GHz.
- 3 GHz to 11 GHz.
- 24,25 GHz to 40,5 GHz.

NOTE: Equipment and antennas operating in the band from 40,5 GHz to 43,5 GHz are not covered by the present document, they are found in EN 301 215-3 and EN 301 997-2 (see bibliography).

However, the specific frequency bands currently recommended by CEPT/ERC/REC 13-04 (see bibliography) as preferred for Fixed Wireless Access, or explicitly mentioned in ERC Report 25 (see bibliography) for Multipoint applications, including infrastructure for fixed or mobile networks, are shown in table 2. The relevant CEPT recommendations for channel arrangements are also shown; the bands are identified in the first column of the table with the commonly used "shorthand" name for the band. Actual assignment of these frequencies on a national or geographic basis is subject to national administration.

Table 2: Frequency bands identified by CEPT for Multipoint Access or Infrastructure applications (see note 1)

Band (GHz)	Frequency limits (MHz)	Basic Channel separations (MHz) (EqC-ChS) (note 2)	Relevant CEPT Recommendations on channel arrangements and assignment	Notes
3,5	3 410 to 3 600	$N \times 0,25$ 1,75; 3,5; 7; 14	CEPT/ERC/REC 14-03 (see bibliography)	
3,5	3 410 to 3 600	5; 10; 15 (20/40/60 \times 0,25)	CEPT/ERC/REC 14-03 (see bibliography)	3
3,7	3 600 to 3 800	$N \times 0,25$ 1,75; 3,5; 7; 14	CEPT/ERC/REC 12-08 (see bibliography)	
3,7	3 600 to 3 800	5; 10; 15 (20/40/60 \times 0,25)	CEPT/ERC/REC 12-08 (see bibliography)	3
10,5	10 150 to 10 300 paired with 10 500 to 10 650	$N \times 0,5$ 3,5; 7; 14; 28	CEPT/ERC/REC 12-05 (see bibliography)	
10,5	10 150 to 10 300 paired with 10 500 to 10 650	5; 10; 15 (10/20/30 \times 0,5)	CEPT/ERC/REC 12-05 (see bibliography)	3
26	24 500 to 26 500	3,5; 7; 14; 28; 56; 112	CEPT/ERC/REC T/R 13-02 annex B (see bibliography) CEPT/ERC/REC 00-05 (see bibliography)	
28	27 500 to 29 500	3,5; 7; 14; 28; 56; 112	CEPT/ERC/REC T/R 13-02 annex C (see bibliography) CEPT/ERC/REC 01-03 (see bibliography)	4
31	31 000 to 31 300	3,5; 7; 14; 28	CEPT/ECC/REC 02-02 (see bibliography)	
32	31 800 to 33 400	3,5; 7; 14; 28; 56	CEPT/ERC/REC 01-02 (see bibliography)	
NOTE 1: The above bands are those specifically identified by CEPT for FWA or multipoint infrastructures for fixed or mobile networks. However, in some cases, mixed P-P and Multipoint systems may be deployed.				
NOTE 2: Basic channel separations are those recommended in the relevant Recommendations and might be related to the size of licensed frequency slots. It is currently assumed that multi-carrier systems may use any number and bandwidth size of sub-carriers within a specific assigned RF channel, as long as the spectrum mask required for that RF channel is not exceeded for any configuration of sub-carriers.				
NOTE 3: Basic ChS defined only for EqC-PET = D in order to define adjacent channel performances and system capacity.				
NOTE 4: This band is allocated for shared use with FSS. CEPT has designated its segmentation to ease its use by FS and FSS in ERC/DEC(00)09 (see bibliography).				

The present document may also be applied to other bands currently assigned by CEPT to Fixed Service (see ERC Report 25 (see bibliography)) or other bands within the frequency ranges covered by the scope of the present document as permitted by national administrations. A schematic picture of the frequency bands covered in the present document is shown in figure 4.

The actual frequency band (EqC-FR) of operation of a particular equipment is one of the components of the Equipment Classification of the particular equipment which determines the frequency range, of which the requirements in the present document apply to that equipment. Annex A defines Equipment Classification (EqC).

Figure 4 shows in diagrammatic form the relationship of the bands specified for antennas, the bands specified for equipment and the bands currently assigned by CEPT to FWA.

Antenna Range (MHz)	Not in scope of this multi-part deliverable						
Equipment Range (MHz)	30 - 1 000						
CEPT FS allocation (MHz)	146 to 174	335,4 to 380	410 to 430	440 to 470	(Note)		
FWA and Multipoint identified bands in CEPT	none						
Antenna Range (MHz)	1 000 - 3 000						
Equipment Range (MHz)	1 000 - 3 000						
CEPT FS allocation (MHz)	1 350 to 1 400	1 427 to 1 452	1 492 to 1 517	2 025 to 2 110	2 200 to 2 290	2 520 to 2 593	2 597 to 2 670
FWA and Multipoint identified bands in CEPT	none						
Antenna Range (MHz)	3 000 - 11 000						
Equipment Range (MHz)	3 000 - 11 000						
CEPT FS allocation (MHz)	3 410 to 3 600	3 600 - 4 200		4 400 to 5 000	5 850 to 8 500	10 150 to 10 300	10 500 to 10 650
FWA and Multipoint identified bands in CEPT	3 410 to 3 600	3 600 to 3 800				10 150 to 10 300	10 500 to 10 650
Antenna Range (GHz)	24,25 - 40,5						
Equipment Range (GHz)	24,25 - 33,4					Not in scope of this multi-part deliverable	
CEPT FS allocation (GHz)	24,25 - 29,5		31,0 to 31,3	31,8 - 33,4		37,0 to 40,5	
FWA and Multipoint identified bands in CEPT	24,5 to 26,5	27,5 to 29,5	31,0 to 31,3	31,8 - 33,4			
NOTE:	The European Common Allocation Table, CEPT/ERC Report 025 (see bibliography) note EU 7 applies to these bands (with the exclusion of few small slots inside) and states: "This band can also be used by low capacity fixed links in rural areas on a national basis. These links need to be co-ordinated with mobile service and require full protection".						

Figure 4: Relationships between the frequency ranges of application of this multi-part deliverable, CEPT FS primary allocations and bands specifically identified for multipoint applications (Not to scale)

5.2 Channel arrangements and block assignment

The channel separation appropriate to the multipoint system envisaged depends on the necessary customer transport capacity, the overall number of customers connected to one CS in a serving area and the access method used.

In table 2, recommended frequency channel arrangements, known at the date of publication of the present document, are shown. The channel arrangement is relevant neither to article 3.2 of R&TTE Directive [1] nor for other requirements in the present document; the frequency range and actual channel separation are only relevant for defining the set of parameters and test suites relevant to each system designed for that channel separation.

The Channel Separation (EqC-ChS) is one of the key components of the Equipment Classification of a particular equipment, which determines which parts of the standard are applicable to that equipment. Other national or future ITU-R or CEPT/ECC recommendations, for the same bands as the present ITU-R or CEPT/ECC recommendations or within the frequency ranges of applicability of the present document, are considered applicable to systems assessed against the present document, provided that they use the same channel separation as indicated in table 3.

For FDD systems, the spacing between corresponding uplink and downlink channels is the duplex spacing; specific sense for uplink and downlink may be required in CEPT Recommendations or in national rules. When applied to TDD equipment, all allocated spectrum may be utilized by the bi-directional TDD signals and in this case references in the present document to duplex spacing should be disregarded.

It should be noted that administrations may consider it more appropriate to allocate spectrum to operators of multipoint systems on a block basis rather than an individual channel basis. As this practice evolves, it is likely that operators will have the freedom to select channel arrangements within their allocation, provided that defined conditions are met. Therefore some developments may require different channel separations for optimizing the spectrum usage within the assigned block. For such purpose this multi-part deliverable is considered applicable to further channel separations by scaling proportionally all channel-related parameters in the present document. Scaling rules and the applicable ranges of ChS are defined in clause 6 and in EN 302 326-2 [6] within each specific requirement clause.

6 Profiles and requirements

6.1 Profiles

6.1.1 General

This multi-part deliverable allows many distinct types of equipment, several different antenna types and several ways in which they might be interconnected to form a network. However, the applicability is limited to certain combinations of attributes and these combinations of attributes are called "profiles". The following clauses address:

- Equipment profiles.
- Antenna profiles.
- System profiles.

6.1.2 Equipment profiles

The applicability of this multi-part deliverable is limited to alternative consistent sets of recommendations and requirements, each for identified equipment profiles, which are defined in terms of their Equipment Classification (EqC), which classify equipments in terms of key characteristics. The profiles (or indeed any specific equipment) within the scope of this multi-part deliverable may be classified as discussed in normative annex A in terms of the various fields of EqC, which are:

- Frequency Range (EqC-FR);
- Primary Equipment Type (EqC-PET);
- Secondary Equipment Type (EqC-SET), (where needed to distinguish variants of EqC-PET);
- Equivalent Modulation Order (EqC-EMO);
- Channel separation (EqC-ChS) - or range of separations;
- Station type (EqC-STN).

Table 3 shows the complete list of equipment profiles within the scope of this multi-part deliverable in terms of the allowed values (or ranges of values) of the various fields of EqC. The manufacturer shall indicate, in the Technical Construction File or elsewhere, the profile that the specific equipment shall comply with, by defining the values of those fields of EqC shown in table 3 that are applicable to the equipment. The equipment shall then comply with *all* requirements in the present document and EN 302 326-2 [6] relevant to that EqC.

In the case of asymmetric MP implementations (see clause 1.6), the supplier shall identify separately the profiles of the equipment in the two alternate directions in terms of the various EqC fields, and this multi-part deliverable shall apply independently to each direction.

Table 3: Equipment Profiles within the scope of this multi-part deliverable defined by their Equipment Classification

EqC-FR Frequency Range (Basic ranges) (note 7)	EqC-PET Primary Equipment Type (note 3)	EqC-EMO Equivalent Modulation Order (note 4)	EqC-SET Secondary Equipment Type (note 5)	EqC-ChS Channel Separation (MHz) (Basic Ranges) (note 6)	
< 1 GHz	T	2	QP, DQ, or GM	No restriction	
	O	2, 4, 6	DM or MA	No restriction	
	F (note 8)	2, 3, 4	Null	No restriction	
	D	Not applicable	OR or PR	3,5 to 20	
	H	Not applicable	Null	1 to 14	
1 GHz to 3 GHz	T	1, 2	Null	1,75 to 4	
	O	2, 4, 6	DM or MA	1,75 to 14	
	F (note 8)	2, 3, 4	Null	1 to 14	
	D	Not applicable	OR or PR	3,5 to 14	
	H	Not applicable	Null	1 to 14	
3 GHz to 11 GHz	T	2	Null	0,025 to 30	
			HC	1,75 to 30	
			LC	0,025 to < 2	
	O	4	Null	0,025 to 30	
			6	1,75 to 30	
			2, 4	DM or MA	0,025 to 30
	F (note 8)	6	DM or MA	1,75 to 30	
			2, 3, 4	Null	1 to 30
			Not applicable	OR or PR	1 to 30
			Not applicable	Null	1 to 30
24,25 GHz to 29,5 GHz	T	2	Null or HC	3,5 to 112	
		4, 6	Null	3,5 to 112	
	M	2, 4, 6	Null	3,5 to 112	
	F (note 8)	2, 3, 4, 6	Null	3,5 to 112	
	D	Not applicable	OR or PR	3,5 to 112	
31,0 GHz to 33,4 GHz	T	2, 4, 6	Null	3,5 to 56	
	M	2, 4, 6	Null	3,5 to 56	
	F (note 8)	2, 3, 4	Null	3,5 to 56	
NOTE 1: A description of the fields of EqC appears in annex A, and the relationship between EqC fields and the previous equipment types described in the superseded ENs appears in annex B.					
NOTE 2: In the earlier standards a number of system types were defined (e.g. A, B, C, etc.). Annex B indicates the relationship between the earlier system types and the present EqC.					
NOTE 3: Although EqC-PET historically has a relationship with a specific multiple access method, any access method, or combination of access methods, may be used provided that the entire set of requirements in the present document and EN 302 326-2 [6] are met for the stated EqC-PET value.					
NOTE 4: In the EqC-EMO column, the reference made to the modulation order is only indicative, and any equivalent modulation scheme is allowed provided that the whole set of requirements in the present document and EN 302 326-2 [6] are met for the manufacturer's stated EqC-EMO value. For mixed-mode systems EqC-EMO=1 might also be provided, among other more efficient EMO, within the same channel separations.					
NOTE 5: For certain primary equipment types (EqC-PET) it has historically been necessary to sub-divide the equipments according to further characteristics which have different consistent sets of requirements. Although no longer tied to specific characteristics, this subdivision is reflected in Secondary Equipment Type (EqC-SET) classifications which are represented by various two-letter codes. (See annex A).					
NOTE 6: The EqC-ChS column indicates range of ChS values for which this multi-part deliverable is applicable. Several parameters in EN 302 326-2 [6] are given for discrete values of ChS only. For intermediate ChS values, methods are given for deriving the required characteristics with the default being by interpolation between the two nearest adjacent ChS values.					
NOTE 7: The EqC-FR column represents the basic frequency range for which this multi-part deliverable is applicable. For assessment purpose the specific frequency band of the equipment/antenna operation should be defined (e.g. EqC-FR = 3,5 or EqC-FR = 3,4 to 3,6) according to the assessment rules for wide band equipment and antennas defined in annex A of EN 302 326-2 [6].					
NOTE 8: Systems of EqC-PET = H, implementing an actual FH-CDMA access method with hopping period exceeding 400 ms, are not considered within the scope of this multi-part deliverable.					

6.1.3 Antenna profiles

According to their characteristics, multipoint systems use different types of antennas as indicated in clause 6.1.4. Table 4 outlines the multipoint antenna types described in EN 302 326-3 [7].

Table 4: Antenna Types

Frequency Range (GHz)	Types	Polarization	Notes
1 to 3	Directional Sectored single beam Omni directional	Linear	The sectored and omni directional antennas may have a symmetric or asymmetric radiation pattern in the elevation plane.
3 to 11	Directional Sectored single beam Sectored multi beam (in the range 3 GHz to 5,9 GHz) Omni directional	Linear	The sectored single and omni directional antennas may have a symmetric or asymmetric radiation pattern in the elevation plane. The sectored multi beam antennas have in elevation a symmetric radiation pattern only.
1 to 11	Directional Sectored single beam Omni directional	Circular	The sectored and omni directional antennas may have a symmetric or asymmetric radiation pattern in the elevation plane.
24,25 to 30	Directional Sectored single beam	Linear	
30 to 40,5	Directional Sectored single beam Omni directional	Linear	The omni directional antennas may have a symmetric or asymmetric radiation pattern in the elevation plane.

This multi-part deliverable is applicable to multipoint radio system antennas of both linear (single or dual) polarization and circular (single or dual) polarization. Linear polarization antennas may support either or both of two mutually perpendicular planes of polarization. These planes are frequently, though not always, horizontal and vertical. Circular polarization antennas may support either right hand or left hand polarization or, for dual polarization, both.

The RPE directional characteristics and polarization characteristics (co-polar and cross-polar and for either linear or circular polarized antennas) impact on the interference to be considered in network planning. A number of antenna options are defined to allow a trade-off between highly demanding RPE directivity and the cost/size/weight of the antennas. The antenna choice should take into account the constraints of present and future networks requirements and constraints.

Annex B of EN 302 326-3 [7] discusses Antenna Profiles for multipoint systems.

6.1.4 System profiles

This multi-part deliverable applies only to Multipoint systems using the following antenna type to station type combinations according to whether the network topology is P-MP or MP-MP (Mesh). Table 5 indicates which system profiles are within the scope of this multi-part deliverable.

**Table 5: System Profiles within the scope of this multi-part deliverable:
Antenna types - Station types combinations**

Network topology	Station types	Antenna types		
		Omni directional	Sectored	Directional
P-MP	Central Station (CS)	Yes	Yes (See note)	No (See note)
	Repeater Station (RS)			
	Facing CS	No	No	Yes
	Facing TS or further RS	Yes	Yes	Yes
	Terminal Station (TS)	No	No	Yes
MP-MP	Repeater Station (RS)	No	No	Yes

NOTE: Sectored antennas with beamwidth < 15° shall conform to the specification otherwise applicable to a directional antenna.

6.2 RF reference architecture

The RF-system block diagram, illustrated in figure 5 shows the point-to-point connection of a MP transceiver between the CS and one TS and vice versa.

When an RS demodulates and remodulates data, this diagram is also applicable to a point-to-point connection between the CS and RS, one RS to another RS, and an RS to a TS.

The "Payload Processing" block contains the mapping functionalities required for transforming between the baseband interface data format and the raw data stream sent to the modulator and received from the demodulator. It includes, but is not limited to transforming between packet data protocols and the raw data stream.

The points shown are reference points only.

Where no payload processing function is present, the following pairs of points may coincide:

- X'_n and Z' .
- X_n and Z .

Where no branching network is present, the following pairs of points may coincide:

- B' and C' .
- B and C .

Where neither branching network nor feeder network is present, the following pairs of points may coincide:

- B' and D' .
- B and D .

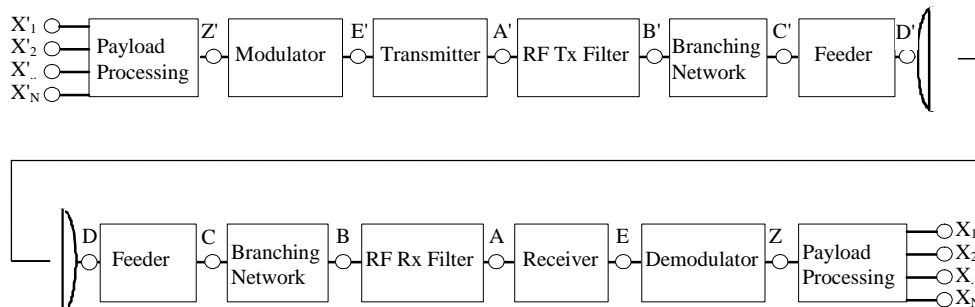

Figure 5: RF system block diagram

6.3 Environmental Profile

6.3.1 General

If the equipment or antenna (or integrated antenna with equipment) are only required to comply with the essential requirements under article 3.2 of R&TTE Directive [1], then the environmental profile within which conformance with all other essential requirements is to be tested has to be declared by the manufacturer as described in EN 302 326-2 [6]. If the manufacturer prefers to assert compliance with an ETSI standardized environmental condition, then the equipment (or integrated antenna with equipment) shall comply with all requirements of this multi-part deliverable within the environmental conditions set out in EN 300 019 [8], which defines weather protected and non-weather protected locations, classes and test severity. Under these circumstances the manufacturer shall state which environmental class the equipment is designed to withstand.

6.3.2 Equipment within weather protected locations (indoor locations)

Equipment intended for operation in temperature controlled locations or partially temperature controlled locations shall meet the requirements of EN 300 019 [8] classes 3.1 and 3.2 respectively.

Optionally, the more stringent requirements of EN 300 019 [8] class 3.3 (Non temperature controlled locations), class 3.4 (Sites with heat trap) and class 3.5 (Sheltered locations) may be applied.

6.3.3 Equipment for non weather protected locations (outdoor locations)

Equipment intended for operation in non weather-protected locations shall meet the requirements of EN 300 019 [8], class 4.1 or 4.1E.

Class 4.1 applies to many European countries and class 4.1E applies to most of Europe.

For systems supplied within a specific radio cabinet, which gives full protection against precipitation, wind, etc. the EN 300 019 [8] classes 3.3, 3.4 and 3.5 may be applied also for equipment intended for operation in non-weather protected locations.

6.3.4 Antennas

If applicable, the radome shall be considered part of the antenna.

There are not specific ETSI standards dealing with environmental conditions of stand alone antennas; however, a non-integral antenna should be designed to operate within a temperature range of -45°C to $+45^{\circ}\text{C}$ with a relative humidity up to 100 % and, for other environmental conditions, may refer to those specified in EN 300 019-1-4 [9].

The temperature range could be divided in two parts where at least one of the following ranges should be covered:

- 1) -33°C to $+40^{\circ}\text{C}$;
- 2) -45°C to $+45^{\circ}\text{C}$.

6.4 Main requirements for equipment

6.4.1 Introduction

Clause 6.4 summarizes requirements related to the "essential requirements" for equipment under article 3.2 of the R&TTE Directive that are further detailed in EN 302 326-2 [6].

However, besides the relevant essential limits set out in EN 302 326-2 [6] published in the EC OJ under the R&TTE Directive, additional requirements in clause 7 may be met if it is desired to achieve full compliance with the requirements of this multi-part ETSI standard applicable to the declared equipment and antenna profile in addition to meeting the essential requirements of the R&TTE Directive [1].

6.4.2 System capacity

The system capacity is the traffic capacity of the system per radio channel of a given size.

Although not explicitly considered an "essential requirement" for equipment under article 3.2 of the R&TTE Directive, there is a relationship between system capacity and efficient spectrum use. This implies a limitation to the minimum value of system capacity for applicability of this multi-part deliverable is necessary. Therefore only equipment that supports at least the minimum capacity (as defined in annex B of EN 302 326-2 [6]) may apply EN 302 326-2 [6] for assessment of R&TTE Directive article 3.2 essential requirements.

For historical reasons, this capacity has been expressed differently for different primary equipment types (EqC-PET) and in different frequency ranges (EqC-FR). In the interests of maintaining continuity with the previous standards, the current version of this multi-part deliverable retains this diversity of definition. It may be expected that future versions of the present document will express the system capacity in a more uniform manner.

6.4.3 Transmit characteristics

Many of the phenomena associated with transmit characteristics are the subject of essential requirements under article 3.2 of R&TTE Directive [1] and, as such, are defined in EN 302 326-2 [6]. Some additional requirements also relate to some transmit characteristics. Table 6 indicates which clauses in EN 302 326-2 [6] address the essential requirements and indicates the additional requirements which are only relevant to the present document.

Table 6: Essential and additional ETSI requirement for transmit characteristics

Essential transmit characteristic (clause heading) specified in EN 302 326-2 [6]	Additional ETSI requirements and notes
Transmitted output power and power control	
Transmitted output power	Notes 1, 2 and 5
Automatic Transmit Power Control (ATPC)	Note 4
Remote Transmit Power Control (RTPC)	
Output power tolerance	Notes 3 and 5
Transmitter output frequency	
Output frequency tolerance	
Remote Frequency Control (RFC)	
Transmitter spectrum density masks	
General requirement	Note 6
Discrete (CW) spectral lines exceeding the spectrum mask (all stations)	
Transmitter spurious emissions	
NOTE 1: The manufacturer shall declare the nominal output power for the CS, TS and RS under full load condition. NOTE 2: ATPC essential requirements only apply if ATPC is implemented. NOTE 3: Besides the tolerance values considered "essential" from the R&TTE Directive point of view, tighter ETSI requirement are reported in clause 7.2.1. NOTE 4: ATPC is an ETSI required feature for the cases reported in clause 7.2.2. In all other cases ATPC is an optional feature. Equipment with ATPC will be subject to manufacturer declaration of the ATPC range and related tolerances. In multi carrier systems, ATPC may be implemented on a common basis, or on a single sub-carrier basis. In either case the spectrum mask shall be met with the maximum provided output power of all sub-carriers. NOTE 5: For mixed-mode and preset-mode systems, the nominal power and power tolerance shall be declared for each modulation order offered. NOTE 6: For mixed-mode and preset-mode systems with assignments made on a per-channel basis, the regulator may wish to include in their licence conditions one transmit spectrum mask appropriate to their national frequency coordination requirements, selected from those applicable to each of the operating modes of the system. For more information, see annex F.	

6.4.4 Receive characteristics

Many of the phenomena associated with receive characteristics are the subject of essential requirements under article 3.2 of R&TTE Directive [1] and, as such, are defined in EN 302 326-2 [6]. Table 7 indicates which clauses in EN 302 326-2 [6] address those essential requirements.

Table 7: Essential requirements for receiver characteristics

Essential receive characteristic (clause heading) specified in EN 302 326-2 [6]
Receiver emissions
Minimum RSL
Single signal performance
Performance at maximum loading (EqC = D only)
Interference sensitivity
Co-channel interference
Adjacent channel interference
CW interference

6.5 Main requirements for antennas

Many of the phenomena associated with antenna characteristics are the subject of essential requirements under article 3.2 of R&TTE Directive [1] and, as such, are defined in EN 302 326-3 [7]. Table 8 indicates the titles of those clauses in EN 302 326-3 [7] which address these essential requirements.

Table 8: Essential and additional ETSI requirement for antenna characteristics

Essential antenna characteristic (clause name) specified in EN 302 326-3 [7]	Additional ETSI requirements and notes
Antenna Co-Polar Radiation Pattern Envelope	
Antenna Cross-Polar Radiation Pattern Envelope	
Antenna Gain	See notes 1 and 2
NOTE 1: Suppliers shall declare the gain of their antennas, which must exceed the minimum values indicated in EN 302 326-3 [7].	
NOTE 2: Regulators might set a more stringent minimum gain requirement in the interface notification under article 4.1.	

7 Complementary requirements

7.1 General

This clause addresses those requirements of multipoint equipment within the scope of the present document that are not related to essential requirements under article 3.2 of the R&TTE Directive [1]. Such requirements are called "complementary requirements". All or some of these complementary requirements are considered useful for proper system operation and deployment. Compliance with all or some of these complementary requirements is on a voluntary basis but must be achieved if full compliance with the present document is claimed.

7.2 System design considerations

7.2.1 Transmit power tolerance

Besides the tolerance necessary for fulfil the provision of R&TTE Directive [1] and reported in EN 302 326-2 [6], equipment intended to be operated in weather protected locations shall be subject to more stringent requirements as follows:

- EqC-FR below 11 GHz: the permitted tolerance is ± 1 dB;
- EqC-FR 24,25 GHz to 33,40 GHz: the permitted tolerance is ± 2 dB.

7.2.2 Transmit power range (ATPC/RTPC)

Implementation of ATPC functionality is an ETSI for uplink transmitters in P-MP systems in the following cases:

- EqC-PET = D with actual DS-CDMA access method in the 24,25 GHz to 29,5 GHz band;
- Transmitters in either direction for MP-MP systems in the 31,0 GHz to 33,4 GHz band that have maximum transmitter power density greater than 0,5 dBm/MHz.

For all equipment classifications, it is appropriate, but not mandatory, for the manufacturer to indicate the range of transmit power covered by ATPC and RTPC.

7.2.3 Input level range

The input level range of the receiver is the range of power levels measured at Point C in the RF Block Diagram (see figure 5) over which the Bit Error Ratio (BER) will not exceed a value which is appropriate to the service type and quality to be delivered. A maximum BER in the range from 10^{-3} to 10^{-6} may be considered typical.

The designed input level range of a receiver should take into account the following system characteristics:

- Maximum variation of distances between stations.
- Non time dependent varying propagation characteristics due, for example to antenna gain tolerance, clutter, non line of sight operation and antenna alignment tolerance.
- Time varying propagation characteristics due, for example, to rain fade.
- Provision of fixed attenuation in either the transmitter or receiver of the station.
- Provision of ATPC and/or RTPC.

An indicative value for input level range of at least 40 dB (accounting for the potential mitigation of ATPC/RTPC, if any) should normally be considered.

Where DS-CDMA is used, then the input level range at the Terminal Station should be greater to accommodate the variation in input power to the receiver depending on the number of channels occupied. The input level range at the Central Station receiver may be less due to the necessity of ATPC/RTPC at the Terminal Station transmitters. An indicative value of 60 dB should be considered at the input to a Terminal Station receiver or the input at a Repeater Station of signals received from a Central Station. An indicative value of 20 dB should be considered at the input at a Central Station receiver or the input at a Repeater Station of signals received from a Terminal Station. Input level range for DS-CDMA equipment, should consider the range of transmit power provided by ATPC. For all equipment classifications, it is appropriate, but not mandatory, for the manufacturer to indicate the input level range of the receiver.

7.2.4 Two tone interference

For multipoint equipment operating at frequencies below 1 GHz, a receiver operating at the RSL specified in the relevant, clause of EN 302 326-2 [6] for a 10^{-6} BER threshold, the introduction of two signals at frequencies offset from the channel centre frequency by $\pm 450\%$ of channel bandwidth and $\pm 900\%$ of channel bandwidth respectively and at a level 30 dB above that RSL should not cause a degradation of more than 1 dB to that RSL/BER threshold.

For multipoint equipment operating at frequencies above 1 GHz, this requirement for immunity to two tone interference, is not considered relevant.

7.2.5 Impulsive interference

For multipoint equipment operating below 1 GHz, the receiver BER shall be measured in the presence of wide band impulsive noise at -102 dBm, measured in a 120 kHz bandwidth with a quasi-peak level detector. The impulses shall be periodic with a repetition rate between 10 Hz and 1 000 Hz. The noise spectrum shall cover all the channel(s) on which the receiver is operating. The manufacturer shall declare the degradation of receiver sensitivity corresponding to a BER = 10^{-3} and 10^{-6} caused by the impulsive noise conditions defined above.

For multipoint equipment operating in frequency ranges above 1 GHz there is no requirement for immunity to impulsive interference.

The rationale for the level of impulsive interference to be applied is as follows:

The test level for man-made noise is derived from the specification for vehicle emissions included in European Directive 95/54/EC (see bibliography). This represents the noise source in rural areas with low vehicle traffic conditions and is also consistent with a number of measurements made in the 0,3 GHz to 1 GHz band for CORDIS/COST Project 207 (see bibliography). The specification level is -112 dBm, quasi-peak, measured in a 120 kHz bandwidth, and exhibits a -20 dB per decade frequency dependence. Other sources of man-made noise are generally at a much lower level (see ITU-R Recommendation P.372 (see bibliography)). In order to account for the worst case scenario whereby the noise arrives on bore-sight of the antenna connected to the equipment, a term is added to account for antenna gain. Because antenna gain is not part of the equipment specification, it is accounted for by using a general term rather than a variable attribute of different antennas. In the frequency range of interest, antenna gain is limited by size (and cost) constraints to a maximum value of around 10 dB at 1 GHz, including feed losses. This increases the noise specification level to -102 dBm at 1 GHz.

For a given physical antenna size, standard antenna theory shows that antenna gain is inversely proportional to the square of the wavelength. It therefore exhibits a +20 dB per decade frequency dependence, and this is followed fairly closely in practical designs within the 0,3 GHz to 1 GHz frequency range. As the frequency dependence of the antenna gain and quasi-peak power are in opposite directions they cancel, removing frequency dependant terms from the present document.

7.2.6 Distortion sensitivity

Multipoint equipment operating in frequencies below 1 GHz should be capable of operating in non line of sight environment. The manufacturer shall specify the equipment capacity and sensitivity under multipath conditions with delay spread ranging from 0 to 20 μ s.

For multipoint in frequency bands above 1 GHz, equipment operate mostly in line of sight conditions; distortion sensitivity due to multipath fading is not considered an important factor justifying a standardized approach. (This contrasts with point-to-point equipment specifications, due to the typically shorter connections of multipoint systems.) Manufacturers should consider implementing countermeasures according to the intended operation of their systems.

7.2.7 System error performance and availability

Equipment shall be designed in order to meet network performance and availability requirements appropriate for the type of traffic carried in a multimedia network. These network requirements (see note) are described by ITU-T Recommendations G.826 [29], G.827 [30] and G.828 [31], by I.356 [32] and I.357 [33] for ATM transmission and Y.1540 [34] and Y.1541 [35] for IP transmission. For transmission of Ethernet frames, network performance requirements of ISO/IEC 8802-3 [13] for 10 Mbit/s Medium Attachment Units and IEEE 802.3 [12] for 100 Mbit/s and 1 000 Mbit/s Physical Layer Devices shall be referred to.

The performance and availability objectives for any overall radio connection operating at capacities below the primary rate, in the high, medium or local grade portions of the network, shall be based on the criteria defined in ITU-R Recommendations F.634 [15], F.695 [16], F.696 [17], F.697 [18] and F.557 [14].

The performance and availability objectives for any overall radio connections operating at capacities at or above the primary rate, used in the international or national portion of the digital path, shall be based on the criteria defined in ITU-R Recommendations F.1668 [26], F.1492 [24] and F.1493 [25].

The effect of the link design on performance is recognized and the general design criteria specified in ITU-R Recommendations F.752 [20], F.1093 [21], F.1101 [22] and F.1102 [23] shall be applied to the digital connection with respect to the propagation scenarios set out in ITU-R Recommendation P.530 [27].

NOTE: An exhaustive list of recommendations for network performance and availability requirements is not in the scope of the present document. The Recommendations referred to in this clause are the basic ones for the most common applications in the fixed networks. Due to continuous evolution of the communication technology, other payloads/network applications might require different or new requirements that should be taken into due account in the equipment and link design for such applications.

7.2.8 Residual bit error ratio (RBER)

The following specification for RBER should be considered a design objective.

The equipment RBER under simulated operating conditions should be measured at the payload interface, reference point X, with a signal applied at reference point B of figure 5 which is 6 dB above the specified RSL for BER = 10^{-6} in EN 302 326-2 [6], taking into account the required test load conditions.

For different payload bit rates the measurement time and the maximum number of errors allowed for digital services are given in table 9.

When packet data payload interfaces are supplied the requirement may be substituted by the equivalent Residual Frame Error Ratio (RFER) as described in informative annex G of EN 302 217-2-1 [3].

Table 9: Maximum number of errors allowed, measuring the RBER

Payload bit rate (kbit/s)	Recording time (h)	Maximum number of errors
≤ 64	20	5
64 to 2 048	(see note 1)	(see note 1)
≥ 2 048 (see note 2)	15	10
NOTE 1: For bit rates between 64 kbit/s and 2 048 kbit/s, the values for the recording time and the maximum number of errors shall be linearly derived from the values for 64 kbit/s and for 2 048 kbit/s, rounding up to the next higher integer value.		
NOTE 2: This requirement corresponds to a RBER $\cong 10 \cdot 10^{-6} \times (2\,048 / \text{Payload-rate})$.		

For systems transporting voice band signals only the maximum number of errors may be relaxed and shall be ≤ 10 during a minimum recording time of 24 minutes.

For MC-TDMA systems, the requirement shall be met by each sub-carrier. The effect of differential attenuation of the sub-carriers, due to different rain intensity within the sector and/or ATPC, shall be taken into account. Therefore the above requirement shall be met with the adjacent sub-carrier(s) RSL set to the higher differential power, with respect to the sub-carrier under actual measurement, permitted by the system implementation, as declared by the supplier.

7.2.9 System availability

All equipment should be designed to meet the availability requirements specified by ITU-R Recommendation F.557 [14], based on the definition of Severely Errored Seconds given in ITU-T Recommendation G.821 [28].

7.3 Interfaces

7.3.1 Power supply

When applicable, the power supply interface shall be in accordance with the characteristics of one or more of the secondary voltages specified in ETS 300 132-1 [2].

NOTE: Other DC secondary voltages or AC mains voltages could be used but relevant standards, if any, are not hereby mentioned; however EMC and safety requirements according to the R&TTE Directive [1] article 3.1, not in the scope of this multi-part deliverable, still apply.

7.3.2 Subscriber interfaces

The equipment covered by this multi-part deliverable shall use one or more of the ETSI, ITU or ISO/IEC (JTC1) standardized subscriber interfaces.

7.3.3 Network interfaces

The equipment covered by this multi-part deliverable shall use one or more of the ETSI, ITU or ISO/IEC (JTC1) standardized network interfaces.

7.3.4 Equipment interface to branching network/feeder/antenna

7.3.4.1 RF connectors and wave guide flanges

For equipment without an integral antenna, the RF interface at reference points C and C' of the RF system block diagram (see figure 5) should be coaxial 50 Ω or an appropriate IEC normalized wave guide flange.

When applicable, the feeder at points D and D' on the RF system block diagram (see figure 5) should be mechanically compatible with the antenna. This should be agreed between the radio equipment supplier and the purchaser in line with the overall systems design requirements. For antennas which are integrated with the radio equipment, proprietary connection designs may be utilized.

When flanges are provided at the antenna port of the radio equipment they should be in accordance with IEC 60154-1 [10] and IEC 60154-2 [11].

Attention is drawn to a range of coaxial connectors referred to in IEC Publication 60339-1 (see bibliography), IEC 60339-2 (see bibliography), IEC Publication 60169-1 (see bibliography), and EN 122 150 (see bibliography). However, it should be noted that these standards are not exhaustive. The impedance of the ports should be nominally 50 Ω coaxial.

For equipment with an integral antenna, an appropriate RF interface (and test fixture if required) is commonly provided to enable the equipment and antenna to be assessed separately. Alternatively, if the required parameters can be measured directly, an RF interface is not required.

7.3.4.2 Return Loss

For equipment according to the present document, that uses outdoor radio frequency units, which are likely to have integral antennas or similar technical solutions, without long feeder connections, the impact of return loss at the antenna port on system performance is negligible. See also the note to table 10.

For outdoor equipment without an integral antenna, the return loss at points C and C' in figure 5 in the direction of the equipment shall, for all systems, be more than the value shown below at the reference impedance.

- Systems < 11 GHz: 10 dB.
- Systems > 24,25 GHz: 14 dB.

For outdoor equipment with an integral antenna there is no requirement. For fully indoor systems, which are generally deployed with longer feeder connections to an external antenna, the suitable return loss depends on the signal bandwidth and modulation complexity.

The minimum requirement would depend on the actual implementation (e.g. error correction code complexity), therefore no standardized values are defined.

For guidance only, the data in table 10 are to be taken into account.

Table 10: Return loss at the C and C' port towards equipment for fully indoor equipment with outdoor antenna

Channel separation (ChS) (MHz) (note 1)	Equivalent Modulation Order (EMO)		
	2	3 and 4	6
ChS \geq 28	14 dB	18 dB	20 dB
28 > ChS \geq 14	Not required	12 dB	16 dB
14 > ChS \geq 7	Not required	Not required	10 dB
7 > ChS	Not required	Not required	Not required

NOTE 1: For TS (and RS), that might have a bandwidth that uses only a portion of the channel used by the corresponding CS, the ChS value should be intended as that utilized portion.

NOTE 2: Not required means that return loss is not an issue for performance but only for potential power loss due to reflection. Even if there might be special cases where RF units designed for outdoor operation are also used in fully indoor conditions, this should be resolved on a case by case basis.

7.3.5 Antenna interface to equipment

7.3.5.1 Antenna input connectors

The input connector of the antenna at points D and D' on the RF system block diagram (see figure 5) should be mechanically compatible with the radio equipment. This should be agreed between the antenna supplier and the purchaser in line with the overall systems design requirements. For antennas which are integrated with the radio equipment, proprietary connection designs may be utilized. In both cases, a suitable test fixture should be agreed and used for test assessment purposes. Alternatively, if the required parameters can be measured directly, an RF interface is not required.

When flanges are provided at the input port of the antenna they should be in accordance with IEC 60154-1 [10] and IEC 60154-2 [11].

Attention is drawn to a range of coaxial connectors referred to in IEC 60339-1 (see bibliography), IEC 60339-2 (see bibliography), IEC 60169-1 (see bibliography), and EN 122 150 (see bibliography). However, it should be noted that these standards are not exhaustive. The impedance of the input ports should be nominally 50 Ω coaxial.

7.3.5.2 VSWR at the input port(s)

The maximum Voltage Standing Wave Ratio (VSWR) should be agreed between the equipment supplier and purchaser in line with the overall system design requirements. For guidance, antennas with a VSWR in the range 1,9 to 1,1 are typical. If applicable, this parameter should be measured with the radome in place.

7.3.5.3 Inter-port isolation

The isolation between the input ports of a dual polarized antenna should be agreed between the equipment supplier and purchaser in line with the overall system design requirements. For guidance inter-port isolation better than 25 dB is typical for linearly polarized antennas and better than 15 dB is typical for circularly polarized antennas.

The isolation between the input ports of a multi-beam antenna should be agreed between the equipment supplier and the purchaser, in line with the overall system design requirements. For guidance, in the case of multi-beam antennas, inter-port isolation is typically 15 dB to 20 dB.

If applicable, this parameter should be measured with the radome in place.

7.4 Environmental and mechanical conditions

7.4.1 Wind loading and ice loading of antennas

The antenna (or integrated antenna together with its associated equipment) should be designed to meet wind survival ratings specified in table 11. If applicable the radome shall be considered part of the antenna.

Table 11: Wind survival ratings

Antenna type	Wind velocity M/s (km/h)	Ice load (density 7 kN/m ³)
Normal duty	55 (200)	25 mm radial ice
Heavy duty	70 (252)	25 mm radial ice

7.4.2 Antenna Labelling

Antennas should be clearly identified with weatherproof permanent label(s) showing all necessary information to identify it clearly (e.g. the manufacturer's name, antenna type, serial number(s) and, where appropriate, polarization direction(s) and any other information relevant to installation and alignment). Integrated antennas may share a common label with the equipment.

For information on possible CE marking under the R&TTE Directive [1], refer to the scope of EN 302 326-3 [7].

7.4.3 Mechanical stability

The antenna (or integrated antenna together with its associated equipment) should be mechanically stable under the most severe operational conditions at the site of intended application. If applicable, the radome should be in place.

For installation purposes, the deviation of the antenna main beam axis should not be more than 0,3 times the smaller of the two azimuth and elevation HPBWs, as a general guide, under the conditions specified in table 12.

Table 12: Antenna stability

Antenna type	Wind velocity m/s (km/h)	Ice load (density 7 kN/m ³)
Normal duty	30 (110)	25 mm radial ice
Heavy duty	45 (164)	25 mm radial ice

Further guidance on other environmental conditions to be withstood may be found in EN 300 019-1-4 [9].

Annex A (normative): Equipment Classification (EqC)

A.1 Rationale

This multi-part deliverable supersedes several separate multipoint equipment standards each addressing different categories of equipment and specifying the characteristics of such equipments. Many of those earlier standards each identified alternative sets of parameter values with which equipment must comply to be considered compliant with the standard. In some of the earlier standards these were referred to as different *system types* usually distinguished by a single letter (or occasionally two letters) - in other cases they are just distinguished by a principal distinguishing feature (such as modulation order). Several of such earlier standards included annexes which indicate "*System Type Codes*", which, together with the standard's own EN number, provided a means of identifying a particular variant equipment covered by the standard. Such identification was intended to be used for licensing purposes, so that the licensor could stipulate specific variants of the standard to be allowed. It was also intended for manufacturers to specify to test houses, and to others concerned with approvals, which variant of the system that is being offered for test. Such references could also be used for procurement purposes.

Within the scope of any specific former multipoint standards, these *System Type Codes* were intended to identify the system in sufficient detail to allow the determination from the EN of the limiting values of relevant parameters and attributes, such as the applicable frequency band (or CEPT frequency/channel plan), the minimum system capacity, the transmit spectrum mask, BER as a function of RSL, and co-channel and adjacent channel interference characteristics.

The System Type Code is superseded by a multi-field reference, each field of which characterizes one aspect of the system. This new means of identifying system variants is called *Equipment Classification* - or *EqC*.

Each equipment variant covered will have an EqC. In the case of asymmetric MP implementations, a different EqC may apply to the alternate directions: receive and transmit.

A.2 EqC as a means of identifying a consistent parameter set for equipment compliance

A.2.1 General

This multi-part deliverable allows several alternative technological approaches to multipoint systems and offers alternative sets of parameters with which equipment shall comply in order to be compliant with the present document. However, the supplier shall indicate which *consistent* set of parameters values that a specific equipment adheres to.

The type of an equipment whose compliance with this multi-part deliverable is being considered is identified by a manufacturer's assertion that it is of a type precisely identified by an Equipment Classification (EqC).

The purpose of EqC is to give the supplier a means to identify unambiguously which of the several alternative consistent sets of parameters values defined in the present document and EN 302 326-2 [6] apply to that equipment.

Some examples of the characteristics which differ according to EqC are:

- The minimum system capacity.
- The transmit spectrum mask.
- BER as a function of RSL.
- Co-channel and adjacent channel interference sensitivity.

The Equipment Classification (EqC) comprises the following fields:

- Primary Equipment Type (EqC-PET).
- Secondary Equipment Type (EqC-SET).
- Equivalent Modulation Order (EqC-EMO).
- Channel Separation (EqC-ChS).
- Frequency Operating Range (EqC-FR).
- Station Type (EqC-ST).

NOTE: Only certain combinations of values of these fields of EqC define Equipment Profiles covered. Combinations within the scope of this multi-part deliverable are shown in clause 6 of the present document.

A.2.2 Primary Equipment Type (EqC-PET)

Primary Equipment Type (PET) may only assume one of the following values:

- T, O, D, H, M, F

NOTE: Historically, these PET values have been related access methods defined by the scope of the former standards. Informative annex B shows the relationship between these values of PET and the scope of former standards. However, there is now no restriction on access method. It is only required that if an equipment is claimed to be of a particular PET, then it shall conform to *all* requirements applicable to that PET.

A.2.3 Secondary Equipment Type (EqC-SET)

For certain of the above EqC- PET values, further variants are within the scope of this multi-part deliverable. The variants are distinguished by a Secondary Equipment Type (EqC-SET) which may only assume one of the following values as shown in table A.1.

Table A.1: Relevant values of Secondary Equipment Type (SET)

Primary Equipment Types	Permitted Secondary Equipment Type
T	HC, LC, QP, GM, DQ, Null
F	FA, FB
D	OR, PR
O	DM, MA
H	Null
M	
NOTE: The origin of these SET codes and their historic meanings and their relationship with system types in former standards is indicated in informative annex B. Their purpose is simply to provide suppliers an unambiguous means, in conjunction with the other fields of EqC, to identify a unique profile and to identify a consistent set of requirements in the present document and EN 302 326-2 [6] which the equipment shall meet. They no longer have meaning beyond that.	

Each value of SET only relates to one specific PET. The valid combinations are only those for which permitted values of the parameters are defined in the present document and EN 302 326-2 [6].

A.2.4 Equivalent Modulation Order (EqC-EMO)

Equivalent Modulation Order (EMO), which is more fully discussed in informative annex E, is related to the modulation and coding scheme applied in the equipment and is related to one aspect of spectral efficiency. Within the scope of the present document, the EMO class may only assume one of the values recognized for the declared PET-SET combination.

NOTE 1: The actual EMO, calculated according to annex E, may not fall within the set of values for the declared PET-SET combination and may not, indeed, be an integer value. Under these circumstances, the declared EMO should be chosen by the manufacturer from the defined set of values (typically, but not necessarily, the closest integer value), such that the equipment complies with all requirements for the declared EMO.

The higher values of Equivalent Modulation Order typically correspond to higher orders of modulation although, provided the equipment satisfies all criteria set for a particular Equivalent Modulation Order throughout the present document and EN 302 326-2 [6], no specific modulation or coding scheme is implied. Indeed Modulation Order represents an indication of the combined effect of the chosen combination of modulation method and coding scheme.

Limiting values of phenomena, which depend upon supplier asserted values of EMO, for some PET-SET combinations include capacity, minimum RSL, transmit spectrum masks, co-channel and adjacent channel rejection.

NOTE 2: Historically, Equivalent Modulation Order was directly related to the order of modulation by the expression $\log_2(\text{number of discrete states which may be assigned to each symbol})$. Thus 2-state modulation would be EMO 1, 4-state modulation would be EMO 2, and 256-state modulation would be EMO 8. However, it is now recognized that designers may trade-off modulation and other characteristics, such as coding schemes, to achieve spectrally efficient performance in terms of capacity, spectrum masks and immunity.

When a variable mode equipment is designed to operate with variable EMO values the supplier shall indicate that it can operate at different EMO and shall list all the different values of EMO that apply. For example, a supplier of multi-mode equipment might indicate EMO = Variable 2, 4, 6 meaning that the equipment may operate with EMO = 2, EMO = 4 or EMO = 6 according to conditions. A discussion of the implications and requirements for multi-mode equipment appears in annex F.

Where a different EMO applies in each direction, the declared EMO shall indicate this by giving the system type for the downstream followed by a hyphen and then the system type for the upstream. For example, a system conforming to EMO 2 in the downstream direction and EMO 4 in the upstream direction should be declared as a EMO 2-4. Where the system type differs for upstream and downstream, the system shall meet all requirements for the declared EMO for each direction independently.

A.2.5 Channel Separation (EqC-ChS)

A RF channel is a partition of a radio frequency band which may be assigned by the authorities in accordance with CEPT, ITU-R Recommendations or national authorities' regulations on channel arrangement.

The Channel Separation (EqC-ChS) is a field of EqC, which, in conjunction with the other fields of EqC, identifies which consistent sets of parameters are relevant to the equipment. EqC-ChS is stated by the supplier as being the separation in MHz between the centre frequencies of neighbouring RF channels relevant to the equipment.

EXAMPLE 1: EqC-ChS = 1,75 MHz.

In cases where the channel separation may vary depending upon the mode of operation of the equipment, the supplier may either indicate the discrete set of values of channel separation which may be used, or the narrowest and widest channel separation which may apply.

EXAMPLE 2: EqC-ChS = 3,5 MHz; 7 MHz; 14 MHz or EqC-ChS = 1 MHz to 4 MHz.

In cases where the RF channel is not implicitly defined by the equipment, as it is often the case for EqC-PET = H systems, where the channel separation is less than the sub-channel bandwidth, the supplier shall indicate a value of EqC-ChS which, in conjunction with the other fields of EqC, defines a consistent set of parameters with which the equipment is asserted to comply.

A.2.6 Frequency Operating Range (EqC-FR)

The following multipoint equipment radio frequency basic ranges are addressed. For an equipment claiming compliance with this multi-part deliverable, the supplier shall indicate its basic range or the specific operation range. This may be done either by identifying which range below applies or by indicating the actual upper and lower frequencies the equipment is intended to operate.

- 30 MHz to 1 GHz.
- 1 GHz to 3 GHz.
- 3 GHz to 11 GHz.
- 24,25 GHz to 29,5 GHz.
- 31,0 GHz to 33,4 GHz.

For example: **EqC-FR = 2,45 MHz to 2,95 MHz**, which indicates the equipment's operational frequency range within the basic range 1 GHz to 3 GHz.

A.2.7 Station Type (EqC-STN)

Three station types are recognized by these standards TS, CS, RS. The supplier shall indicate whether a specific equipment is a Terminal Station (TS), a Central Station (CS) or a Repeater Station (RS).

Example of a supplier indication of station type: **EqC-STN = TS**.

Annex B (informative): Relationship between superseded standards and Equipment Classification (EqC) of equipment profiles

As indicated in the Foreword to the present document this multi-part deliverable will replace and supersede, after a suitable transition period the standards that there are listed. The characteristics of equipment considered in those ENs have also been rationalized, re-compacted and re-subdivided into the various sub parts of this multi-part deliverable.

This multi-part deliverable contains requirements that have been derived, with further rationalization, from a set of previous ENs that were applicable only to multipoint radio systems using the following access techniques:

- 30 MHz to 3 GHz: TDMA, FDMA, DS-CDMA and FH-CDMA.
- 3 GHz to 11 GHz: TDMA, FDMA, DS-CDMA, FH-CDMA and TDMA/OFDMA.
- 24,25 GHz to 29,50 GHz: TDMA, MC-TDMA, FDMA and DS-CDMA.
- 31,00 GHz to 33,40 GHz: TDMA, MC-TDMA and FDMA.

This annex indicates the relationship between the various superseded multipoint equipments ENs (and the variants of equipments defined therein) and the various Equipment Classifications described within the present document that supersede them.

Table B.1 shows how the various equipments described in terms of frequency range, access method and in some cases, system type or equipment class can be mapped onto the profiles of this multi-part deliverable. In general, equipment which was compliant with one of the superseded ENs will be compliant with this multi-part deliverable with the indicated Equipment Classification.

This multi-part deliverable is however less stringent in the following ways.

- The superseded standards were explicit on the multi access method to be permitted. However, it has been recognized that the specific access method does not impact on the coexistence of different systems (which is related only to radio frequency parameters). This multi-part deliverable permits *any* access method (or combinations of access methods) provided that all the provisions of a single corresponding subset of a "Primary Equipment Type" (EqC-PET) are met.
- Similarly, several of the superseded ENs make references to explicitly stated orders of modulation (usually expressed as "n-state modulation"). This multi-part deliverable permits *any* modulation (and coding) processes provided that all the requirements related to the stated "Equivalent Modulation Order" (EqC-EMO) within the selected subset are met.

Table B.2 shows the historic meanings of the various PET and SET codes. However, it is stressed that these no longer have such meanings within this multi-part deliverable and their purpose is solely to provide an unambiguous means for the supplier to indicate with which consistent set of requirements in the present document and EN 302 326-2 [6] the equipment is claimed to comply.

Table B.1: Equipment classifications corresponding to MP equipment of former ENs

Equipment description in former standards				Equipment classification (EqC-)			Remarks		
Freq Range (GHz)	Access Method	ETSI MP Equipment EN	Variants/System Types	PET Primy equip type	EMO Eqv mod order	SET Secy equip type			
< 1	Common	EN 301 460-1	N/A						
	TDMA	EN 301 460-2	See remarks	T	2	QP	QPSK modulation		
						GM	GMSK modulation		
						DQ	DQPSK modulation		
	FDMA	EN 301 460-4	N/A	F	2, 3, 4				
	DS-CDMA	EN 301 460-5	ClassA ClassB	D	Any	OR	orthogonal coding		
PR						pseudo random coding			
FH-CDMA	EN 301 460-3	N/A	H	Any					
1 to 3	TDMA	EN 300 636		T	1, 2				
	FDMA	EN 301 373	Type A	F	2, 3, 4	FA			
			Type B			FB			
	DS-CDMA	EN 301 055	ClassA ClassB	D	Any	OR	orthogonal coding		
			PR			pseudo random coding			
FH-CDMA	EN 301 179		H	Any					
3 to 11	TDMA	EN 301 021	Type A	T	2		low order modulation		
			Type HC			HC	better receiver sensitivity and interference immunity		
			Type C			LC	lower complexity modulation; gross bit rate below < 2 Mbit/s; TDD only		
			Type B			4	medium order modulation		
			Type D			6	higher order modulation		
			Type E			O	2	DM	lower order OFDM modulation, ditto with TDMA/OFDMA access
			Type F				4	DM	medium order OFDM modulation ditto with TDMA/OFDMA access
			Type G			6	DM	higher order OFDM modulation ditto with TDMA/OFDMA access	
	FDMA	EN 301 080	Type A Type B	F	2, 3, 4	FA			
						FB			
	DS-CDMA	EN 301 124		D	Any				
FH-CDMA	EN 301 253		H	Any					
24,25 to 29,5	Common	EN 301 213-1							
	TDMA	EN 301 213-3	Type A	T	2		lower complexity modulation		
			Type HC			HC	better receiver sensitivity and interference immunity		
			Type B			4	medium complexity modulation		
			Type C			6	higher complexity modulation		
	MC-TDMA	EN 301 213-5		M	2		lower complexity modulation		
			4		medium complexity modulation				
			6		higher complexity modulation				
FDMA	EN 301 213-2		F	2, 3, 4					
DS-CDMA	EN 301 213-4		D	Any					
31,0 to 33,4	Common	EN 302 063							
	TDMA	EN 302 063 annex A	Type A	T	2		lower complexity modulation		
			Type HC				better receiver sensitivity and interference immunity		
			Type B			4	medium complexity modulation		
			Type C			6	higher complexity modulation		
	MC-TDMA	EN 302 063 annex C	Type A	M	2		lower complexity modulation		
			Type B		4	medium complexity modulation			
Type C			6		higher complexity modulation				
FDMA	EN 302 063 annex B		F	2, 3, 4					

Table B.2: Historic meanings of Primary and Secondary Equipment Type

Primary Equipment Types	Historic Meaning (Access Method)	Secondary Equipment Type	Historic Meaning
T	TDMA	HC	High compatibility
		LC	Lower complexity System Type C, only applicable for FR 3 GHz to 11 GHz
		QP	QPSK, only applicable for FR below 1 GHz
		GM	GMSK, only applicable for FR below 1 GHz
		DQ	DQPSK, only applicable for FR below 1 GHz
		Null	No special attributes
F	FDMA	FA	Type A
		FB	Type B
D	DS-CDMA	OR	Orthogonal coding
		PR	Pseudo random coding
O	TDMA/OFDMA	DM	OFDM
		MA	OFDMA
H	FH-CDMA	None applicable	
M	MC-TDMA	None applicable	

Annex C (informative): Receiver selectivity and noise figure

In order to facilitate interference calculations with other services both within and from outside the Fixed Service, the receiver selectivity and noise figure should be made available by the manufacturer.

Annex D (informative): Traffic path characteristics

D.1 Synchronization of traffic interfaces

Systems providing services based on the transport of constant bit rate digital data may be required to synchronize the transmitted data to the digital bit stream received from the core network. Where such services are supported, appropriate internal and/or external synchronization should be provided.

In the extreme case where systems provide services from two or more core networks which are not synchronized with each other, the system may be required to synchronize independently the transmitted data corresponding to the digital service from each independent core network.

The principles for synchronization should be according to ITU-T Recommendation G.810 (see bibliography). Tolerances should be according to ITU-T Recommendations G.812 (see bibliography) and G.823 (see bibliography) for systems providing PDH interfaces and/or ITU-T Recommendations G.813 (see bibliography) and G.825 (see bibliography) for systems providing SDH interfaces.

D.2 Round trip delay

This requirement was relevant to "traditional" TDM/voice only 64 kbit/s "WLL" systems. Current MP systems generally offer a mixture of services, combining voice and/or data, over a variety of data rates, including IP services.

The round trip delay is defined with reference to figures 2 and 3 in clause 4, which depict representative examples of P-MP and Mesh network architectures. It is the delay from the Terminal Interface to the Core Network Interface and back to the Terminal Interface. The characteristics of the round trip delay should be stated by the manufacturer.

System designers are advised that for systems intended for voice traffic encoded at 64 kbit/s, the round trip delay should not exceed 20 ms if echo cancellers are not used. In order to avoid any degradation of the quality telephony communication caused by round trip delay introduced by the multipoint system into the transmission network, designers should consider the provisions of ITU-T Recommendation G.131 (see bibliography).

D.3 Voice coding methods

For systems providing voice services, it is recommended that at least one of the following coding methods should be used:

- 64 kbit/s ITU-T Recommendation G.711 (see bibliography);
- 32 kbit/s ITU-T Recommendation G.726 (see bibliography);
- 16 kbit/s ITU-T Recommendation G.728 (see bibliography);
- 8 kbit/s ITU-T Recommendation G.729 (see bibliography);
- 5,3/6,3 kbit/s, dual rate ITU-T Recommendation G.723.1 (see bibliography).

Other voice coding methods may be employed if the quality is adequate for the service provided. It is recommended that, in order to assess the adequacy of the quality for the service provided, it should be measured in Quantization Distortion Units (QDU) or Mean Opinion Score (MOS) and compared with that of the coding methods listed above.

It should be noted that ITU-T Recommendation G.711 (see bibliography) provides transparency to all voice band signalling and data modem signals and is provided as a digital interface to many digital switches. It should be noted that for the majority of European applications, the A law companding option in ITU-T Recommendation G.711 (see bibliography) should be selected for compatibility with the switch.

It is recommended that the coding method or methods used should be stated by the manufacturer.

D.4 Transparency

The services offered over the Radio system should be, as far as possible, fully transparent. By this, it is meant that, with reference to figures 2 and 3, the Core Network and the Terminal Equipment communicate with each other without being aware of the radio link.

Exceptions to this requirement for transparency are as follows:

Concentration of voice and data traffic may be employed to increase the efficiency of spectrum utilization. It should be noted that features of concentration may affect the network design, including the following:

- the means by which circuit unavailability is signalled to the user and/or network for circuit switched calls;
- the means by which flow control is signalled to the user and/or network for data transmission;
- the rules by which data are discarded if flow control is not supported.

Aggregated interfaces at the network interface may be employed. In this instance, the type of transcoding of speech, data, addressing, or signalling applicable to the change in interface type between the user interface and the network interface may affect the network design.

Compression of traffic may be employed to increase the efficiency of spectrum utilization. Examples of such techniques are companding, speech codecs and digital speech interpolation. The standards or algorithms to which the compression and decompression functions conform may affect the network design and it should be noted that some types of traffic (e.g. voice band data) may not be supported on circuits employing these techniques.

Data routing and/or filtering may be supported by the radio system. In this case, the filtering and routing algorithms supported, together with any address translation will affect the network design, as will the method by which such routing or filtering functions are configured.

Reduction of data rate or increased error rate may occur due to interference or propagation effects and any signalling used from the radio system to the user or the network to indicate that the link is unavailable or available only with restricted bit rate or increased error rate should be taken into account in the network design.

Annex E (informative): Typical reference model for BER, MGBR and EMO

E.1 General

The R&TTE Directive [1] recognizes that mandatory requirements may apply in order to use the spectrum effectively. A large number of factors contribute to the spectral efficiency of a deployed system, but two key parameters have historically been recognized and specified: Minimum Gross Bit Rate (MGBR) and modulation order. Historically, FDMA systems have specified the payload data rate in place of the MGBR, while systems employing other access methods have specified the MGBR as the instantaneous bit rate applied to the modulator when user data are being carried.

Since the addition of functionality not present in previous systems, such as forward error correction and payload processing, the definitions of minimum gross bit rate and modulation order have become potential sources of misunderstanding.

It should be noted that the data rate currently specified for Point-to-Point systems is reduced by overhead used for error correction and consideration should be given in moving towards a harmonized definition of data rate in that it should not apparently make Point-to-Point systems appear less spectrally efficient than Multipoint systems.

For all systems currently envisaged as being within the scope of this multi-part deliverable, the rate at which symbols (distinct states of the analogue signal output from the modulator) are transmitted is a constant and is referred to as the symbol rate.

For the purpose of this multi-part deliverable, a new parameter is defined, Equivalent Modulation Order (EMO) which represents the ratio of the bit rate (during a transmission burst, if applicable) at the chosen reference point to the symbol rate. It may be seen that in systems without FEC, the EMO is equivalent to the modulation order. This definition of EMO is independent of duplex method (e.g. FDD or TDD).

This annex describes a typical reference architecture of part of the multipoint radio equipment which may be used by a manufacturer, if desired, to define the reference point for which measurement of Bit Error Rate (BER), and declaration of Minimum Gross Bit Rate (MGBR) and Equivalent Modulation Order (EMO) may be made. The EMO declaration must be constrained to one of the values in the appropriate equipment profile. It should be noted that for certain types of system this architecture may be varied, in which case this annex may be of limited applicability.

The reference architecture described in figure E.1 of this annex should be viewed as an expansion of the blocks between and including the payload processing and modulation (demodulation for the receive direction) blocks in the system reference architecture shown in figure 5. The reference points X'_N and E' correspond to the equivalent points in the system reference architecture shown in figure 5. The reference point Z' in the system reference architecture is not directly related to any reference point in the architecture described in this annex. The reference points P to T within the architecture described in this annex are specific to this annex and do not directly correspond with the reference points in the system reference architecture shown in figure 5.

The reference architecture for the transmit direction is shown in figure E.1. The architecture for the receive direction is a mirror image of the transmit direction, although it should be noted that certain functions, such as ARQ, require interaction between the transmit and receive data streams.

The reference points in this architecture are conceptual and may not relate to an accessible physical interface in the equipment.

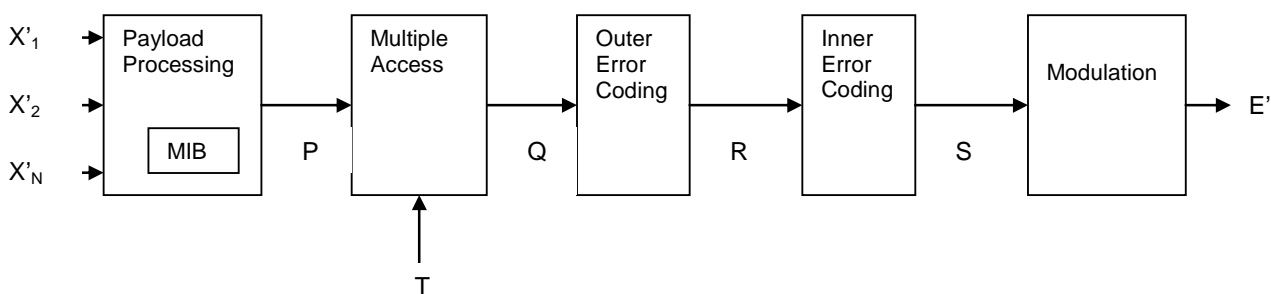

Figure E.1: Reference architecture - transmit direction

E.2 Interface X'_1 to X'_N

The reference points are the points of connection between the radio equipment and the terminal or network equipment from which user data are submitted to the radio equipment for transmission.

It may be noted that the raw data rates at points X'_1 to X'_N may not bear a direct relationship to the data rate over the air. As an example, interfaces such as 100baseT may be appropriate at these reference points although the data rate over the radio system may only be of the order of a few Mbit/s.

E.3 Payload processing block

The payload processing block may perform a range of functions to extract, switch and process user data presented at interfaces X'_1 to X'_N , the data required to be transmitted over the radio link being output at reference point P.

Some management protocols, such as Simple Network Management Protocol (SNMP) operate using data which are encoded as packets in the same or similar way to the user data and are transmitted in the same data stream as the user data. These protocols typically control and monitor the hardware parameters of the equipment via a data array called the Management Information Block (MIB). Given the similarity, in this case, of the transmission of network management data to the transmission of user data, it is appropriate to include such functions in the payload processing block.

Some systems provide Automatic Repeat reQuest (ARQ) error correction within the Data Link Control (DLC) function such that packets of data which are lost or received in error are caused to be retransmitted by the radio equipment. Since the proportion of the available data rate used by the protocol overhead of such systems is both variable and also low, it is appropriate to include ARQ within the payload processing block.

Consideration should, however, be given to the added value inherent in such systems in that the error rate of user data is reduced to a very low value, although at the expense of overhead and delay. Again, should this function be included in measuring the BER, it is important that the consequent loss of user capacity be taken into account in declaring the bit rate of the system and noting that the overhead will vary with the error rate of the channel. It should also be noted that the BER may be immeasurably low and that the delay may be both variable and indeterminate.

Where the payload processing includes a Multiple Access Control (MAC) layer, it is important to distinguish between this protocol layer, which is applicable to the user data interfaces, and the multiple access function described below which is applicable to the appropriate routing between radio stations in the multipoint system. Under some circumstances these two functions may be combined and it is then necessary to evaluate the effect of this function on the available bit rate of the system to convey user data between radio stations.

E.4 Multiple access block

The multiple access block accepts data from the payload processing block at reference point P. At the CS, the function of the multiple access block is to split of data destined for different TSs and to present these data to the error correcting and modulation functions such that they will be received by the appropriate TS. There may be multiple instances of the error correcting and modulation functions. At the TS, the function of the multiple access block is to transmit the data destined for the CS in such way as to be independent from and not interfering with data from other TSs. There are several means by which this may be accomplished, such as placing data in separate timeslots or placing data in separate carriers.

In the specific instance of DS-CDMA systems, the modulation process is preceded by the convolution of the output data for each channel with a code at a higher bit rate (the chip rate). In this instance, the function of multiple access might be preceded by the outer error coding (see clause E.5) and following the inner error coding (see clause E.6).

In the circumstance where the data are separated in the time domain, the multiple access block may generate timing signals to the modulator(s) to define, for example, the starts of frames.

Where Time Division Duplex (TDD) is used, it may be appropriate to include the duplex control functions within the multiple access control block. It thus follows that the selection of reference point Q or R for the declaration of MGBR and EMO and the measurement of BER is not affected by the use of TDD as opposed to FDD.

In the process of encoding and timing data in the multiple access block, network management may be introduced, shown in the figure as data inserted at reference point T. This information may be carried in various forms, such as additional timeslots or additional carriers.

It should be noted certain systems permit packets of data from TSs to collide and are then retransmitted either if collisions are detected or the packets of data are not received. This function can be regarded as a multiple access technique, although consideration should be given to the fact that the overhead of this multiple access function is not constant but rises with increasing traffic.

The data required to be transmitted, including additional data for access control and management, are passed to the outer error correcting block at reference point Q.

E.5 Outer error correcting block

Many systems provide two levels of Forward Error Correction (FEC) and it is usual to designate these as an outer (furthest from the modulator) and inner (nearest the modulator) code.

The outer error correction is not linked to the modulation process and could, in principle, operate on any bitstream. Such error correcting schemes typically operate by framing the data and then introducing a number of additional bits which may detect errors and, typically, correct a smaller number of such errors. Error correcting schemes of this type introduce a small overhead to the data stream but only correct errors at an error rate which introduces a small number of bit errors per frame. An example of such an error correcting scheme is Reed-Solomon coding.

The data required to be transmitted, including additional data introduced by the outer coding, are passed to the inner error correcting block at reference point R.

E.6 Inner error correcting block

The inner error correction is linked to the modulation process. Typically, the error correction coding involves limiting the number of valid states that may be transmitted in each symbol, depending on the state of the preceding symbol. The separation between the permitted states of two successive symbols is thus larger than it would have been had any state been permitted for each symbol. Thus, the demodulation process will operate correctly in the presence of a larger noise signal than would have otherwise been the case.

The inner error correcting block passes information to the modulator block at reference point S. Typically, for each symbol to be transmitted, the inner error correcting block provides a binary code which determines the state to be transmitted in the following symbol.

In the receive direction, the demodulator may pass to the inner error correcting block a decoded binary value representing the state of the received symbol (hard decoding) or it may pass a binary representation of the value of the received symbol (for example, the amplitude of the in phase and quadrature elements of the received symbol) at a higher resolution (soft decoding) which permits more intelligent decision making by the inner decoder.

In the case of an inner error correction code which places a limit on the states which are permitted to be output via the modulator, it is appropriate to define the EMO according to the number of permitted states for each symbol, rather than the total number of states which the modulator may transmit.

Thus, for a QAM system without FEC in which the modulator may transmit any of 16 states, the EMO would be $\log_2(16) = 4$. In a QAM system using FEC which only permits 8 out of the 16 available states to be used for each symbol, the EMO would be $\log_2(8) = 3$.

E.7 Modulator

The modulator takes a digital representation of each symbol to be transmitted and uses this value to alter the parameters of an analogue signal (e.g. amplitude or phase) on a per symbol basis. The transition of these analogue parameters from one state to another is normally controlled by either filtering the baseband digital signals or filtering the output of the modulation process such that the output of the modulator is band limited.

The output of the modulator is presented at reference point E' to the following processes of translating the signal to the desired frequency and amplifying it to the desired level and impedance to match the feeder and antenna.

E.8 Choice of reference point for BER, MGBR and EMO

The reference point for the declaration of MGBR and EMO should be such that the capacity of the system is fairly described in relation to other such systems and any coding gain from the error correction is balanced with a corresponding loss in MGBR (i.e. the reference point for BER should be coincident with that for MGBR).

The reference point should be such that the BER can be measured. Such measurement may be by intercepting data directly at the reference point, by measuring the BER at the user interfaces with all error correction between the user interface and the reference point disabled, or any other method agreed with the test house (e.g. the use of internal diagnostic facilities).

In the typical reference architecture above, it would be appropriate to select either the reference point at Q or R as that at which BER is measured and MGBR and EMO are declared, since this, in principle, removes any dependence on the nature of the payload processing and access control. In either case, the coding gain from the FEC is balanced against the consequent loss in MGBR enabling fair comparisons with other systems to be made.

Where a FEC is used which combines the characteristics of inner and outer coding (e.g. Turbo coding), it would be appropriate to select reference point Q and reference point R would not exist.

Where the system comprises multiple instances of the error correction and modulation functions, the MGBR should be defined as the sum of MGBRs across all modulators.

E.9 Examples

E.9.1 16 QAM TDMA system with $\frac{3}{4}$ rate convolutional coding

For a 16 QAM TDMA system with $\frac{3}{4}$ rate convolutional coding (e.g. Bidimensional 16TCM), the inner coding block is present, but not the outer coding block. Reference point Q does not exist and the multiple access block is connected directly to the inner coding block at reference point R.

Given the selection of reference point R, the EMO would be $\frac{3}{4} \times \log_2(16) = 3$.

E.9.2 16 QAM TDMA system with $\frac{1}{2}$ rate convolutional coding and 204/188 Reed Solomon coding

For a 16 QAM TDMA system with $\frac{1}{2}$ rate convolutional coding and 204/188 Reed Solomon coding, both coding blocks are present.

Given the selection of reference point Q, the unconstrained EMO would be $188/204 \times \frac{1}{2} \times \log_2(16) = 1,843$. However, given that the EMO is constrained to be one of the permitted values in the profile, the declared EMO might be 1 or 2. Given either declaration, both the bit rate per Hz and the BER specifications shall both be met for the declared EMO.

E.9.3 16 QAM TDMA system with $\frac{1}{2}$ rate turbo coding

Turbo coding can exceed the performance of concatenated (inner and outer) coding and, given a long enough block length, can approach the Shannon limit. It is therefore convenient to view turbo coding as equivalent to the combination of the inner and outer coding blocks, which are merged into one coding block with reference point R no longer applicable.

Given the selection of reference point Q, the EMO would be $\frac{1}{2} \times \log_2(16) = 2$.

E.9.4 16 QAM FDMA system with $\frac{1}{2}$ rate convolutional coding

In a 16 QAM FDMA system with $\frac{1}{2}$ rate convolutional coding, the multiple access block would be connected at point R to N multiple instances of the outer coding and modulator blocks, where N is the number of FDMA sub channels.

In this case, given selection of reference point R, the EMO would be $\frac{1}{2} \times \log_2(16) = 2$ and the bit rate would be the sum of the bit rates at the multiple interface points R between the multiple access block and the N inner coding blocks.

Annex F (informative): Mixed-mode operation

F.1 Introduction

This annex is intended to offer guidance on the application of spectrum density masks and receiver interference immunity (defined in EN 302 326-2 [6]) in the context of mixed-mode systems. The guidance is considered necessary due to the fact that, at the time of publication of the present document, there are no ECC harmonized frequency planning assumptions and coexistence rules valid in all FWA frequency bands, nor for all system options currently standardized and available on the market (e.g. system modulation orders, access methods and channel separations).

F.2 General description of mixed-mode systems

Systems applying mixed-mode technology use different modulation orders according to the actual network needs (e.g. according to the range of Terminal Stations, assigned capacity, and severity of propagation channel distortion).

The different modulation order might be selected by a simple presetting, statically defining which modulation order is to be used by a particular CS or TS; in this case it is more appropriate to refer to preset-mode systems, for which spectrum mask and other requirements are already considered in EN 302 326-2 [6]. Preset-mode (or "multi-format") systems also have the capability to change the modulation order through remote controls according to the Operator and Customer needs.

The term "mixed-mode systems" is appropriate when the modulation order can be changed dynamically, for example:

- A TDMA CS might use different modulation orders on a slot-by-slot base according to the TS addressed by that slot. An FDMA CS might use different modulation orders on a carrier-by-carrier basis. The modulation order might also be changed to adapt to varying propagation channel impairments, or for a change in service profile.
- The corresponding TS would use one modulation order until the network situation changes due to either propagation channel impairments, or a change in service profile (e.g. a different service profile might be achieved using a more robust modulation or higher spectral efficiency).

F.3 Historical derivation of transmit spectrum masks

Earlier ETSI ENs for Fixed Radio Systems generally defined a set of masks, one for each standardized emission class (related to a typical modulation order, e.g. 4 QAM, 16 QAM and 64 QAM). The transmit spectrum masks defined in EN 302 326-2 [6] are derived from similar masks specified in earlier point-to-point standards.

These historical masks were specified for two reasons:

- a) In order to permit planning of point-to-point systems operating on adjacent or near adjacent channels over the same physical link and potentially using equipment from different manufacturers and with a different air interface specification. In defining the masks in this way, the assumption was made that the channel filtering was equally divided between transmitter and receiver and that the NFD could thus be calculated on the assumption that the receive mask would match the transmit mask. It was also assumed that the permissible carrier to interference ratio was determined by the modulation type and order and without specifically taking into account possible forward error correction improvement.
- b) In order to permit planning of link parameters to ensure coexistence of geographically separated links.

F.4 Rationale for Multipoint transmit masks

F.4.1 Introduction

The transmit spectrum masks should be determined only by the requirements of inter systems planning (reason b) above), for differing systems that are separated geographically or in frequency. Such determination should be technology neutral. The determination of the transmit spectrum mask as a means of achieving intra system adjacent channel performance (reason a) above) is no longer considered relevant to multipoint systems for reasons given below and hence the determination of transmit spectral masks and co-channel and adjacent channel interference sensitivity should be completely decoupled.

The following clauses explain the detailed reasons for this decoupling.

F.4.2 Irrelevance of ETSI transmit spectrum mask in determining adjacent channel requirement for intra-system planning

An operator using multipoint systems will typically plan the deployment in a given geographical area or frequency range based on actual manufacturers' data. The Tx spectrum mask cannot be assumed to be directly related to the receive selectivity mask.

F.4.3 Applicability of the transmit spectrum mask to inter-system planning

It is essential that regulators should have sufficient data to ensure the compatibility of different operators' systems, given that the operators adhere to the licence conditions. This may be achieved by definition of geographical areas and co-ordination zones, provision of guard bands, power limitations and specification of modulation type and lowest permitted equivalent modulation order (i.e. the EqC EMO specified in the present document).

Similarly, it may be expected that operators using mixed-mode systems will deploy the same equipment throughout their licensed block or, alternatively, introduce guard bands between sub blocks within their licensed block which are used for different equipment.

In order to ensure spectral efficiency and optimal guard band allocation, administrations might choose to specify, in their interface notification under article 4.1 of the R&TTE Directive [1], a minimum declared EMO (as defined in annex E) which may be used. So, for example, a mixed-mode system providing EMOs 2, 4 and 6 might be constrained to use EMOs of 4 and 6 only, to meet the requirements of an administration. It therefore follows that, in order to permit efficient guard band planning, the system must, at all times, meet the transmit spectral mask of the lowest EMO enabled, but, correspondingly, need not meet the adjacent channel performance with an interfering signal of any lower order than that which may be enabled.

The following is a practical example of the above concepts:

Assuming a mixed-mode system operating with EMO = 2, 4 and 6 (e.g. 4 QAM, 16 QAM and 64 QAM formats) is deployed in a situation where the administration has decided to limit the licence to a declared EMO equal to 4 or higher; the 16 and 64 QAM formats only should be enabled (fulfilling the EMO = 4 mask). The 4 QAM format should be disabled or, if agreed by the administration, used only for special conditions enhancing the effective use of the spectrum but still remaining within the EMO = 4 spectrum mask.

However, provided that the same licensing rule is adopted for all operators, the system will not be subject to co-channel or adjacent channel interference from systems with transmit emission worse than EMO = 4 mask.

F.4.4 Minimum traffic capacity imposed by the regulator

It should be noted that regulators (administrations) sometimes, in the interests of spectral efficiency, restrict licences to modulation orders (i.e. EMOs in the present document) at or greater than a specified limit or, alternatively and preferably, specify a spectral efficiency lower limit in a way which is technology independent. Under these circumstances it should be noted that a mixed-mode system which can meet such constraints when operating at the minimum licensed EMO or above, might switch to a lower modulation order only to improve geographical coverage, interference immunity, or frequency reuse. Such switching would therefore improve the overall spectral efficiency of a deployed system and the regulator (administration) should be encouraged to permit mixed-mode switching to a modulation order lower than the EMO that would otherwise have been set in the licence conditions.

For these reasons, consideration should be given to 3 points:

- 1) Minimum capacity in FWA systems is not directly related to the modulation format (e.g. start-up operators may be burdened by the restriction (in the licensed EMO) of using only a higher modulation order when in fact they may not achieve sufficient geographic coverage due to power limitations). The capacity should thus remain only as a long-term objective. It may be achieved by other regulatory means than requiring a minimum EMO.
- 2) In the event that the planning assumptions are made based on the highest EMO defined in the present document, nevertheless, for short periods (e.g. during a rain fade), the system should be allowed to activate the lower actual modulation orders whilst still maintaining the same spectrum mask, in order to provide service.
- 3) In the event that a frequency band is "channelized", and frequencies are assigned on an individual channel basis, then the regulator might wish to impose the more stringent requirement on the transmit spectrum mask, in order to improve adjacent channel performance. In that case, the mixed-mode systems would be restricted to use the most stringent mask, for declared EMOs, applicable to the actual modulation orders offered. However, this is not considered an essential requirement under article 3.2 of the R&TTE Directive [1].

F.5 Essential requirements for transmitters and receivers operating in mixed-mode

F.5.1 Requirements summary

The sole requirement for a transmit spectrum mask should be to ensure that planning can be undertaken such that no interference occurs between systems in adjacent geographical blocks or frequency blocks (considered to be the frequency ranges assigned to different operators). The co-channel and adjacent channel performance of systems deployed by an operator within a block may be achieved by whatever means the manufacturer adopts. It is noted that technically, in the limit, a block may currently be as small as one channel, although this is not expected normally to be the case.

The essential requirement should therefore be a mask or set of masks which allows inter-system coexistence to be planned and a set of co-channel and adjacent channel interference C/I values (one for each modulation mode implemented) to be met by the victim receiver (operating in one mode only at the time) with an interfering transmitter operating in any modulation mode implemented.

F.5.2 Transmit spectrum masks for mixed-mode

The manufacturer should declare which combination of modulation orders (in terms of declared EMOs) the equipment offers, and for each actual modulation order should be compliant with the appropriate mask of the declared EMOs. Planning decisions may then be taken on the basis of the least stringent mask which may be selected (the subset of those supported by the equipment, which are also permitted by the licence).

These requirements apply only for the assessment of essential requirements under article 3.2 of the R&TTE Directive [1]. It is assumed that, when operational, the system should meet only the mask of the lowest licensed EMO, in terms of absolute power density in dBm/MHz, (e.g. in order to optimize service, the system is able to adjust the power of the more complex modulation formats even if exceeding their own mask, provided that the least stringent absolute power density mask is always met in all static and transient conditions, including any training bursts or reference signals). It should be noted that a possible overlapping of EMO masks would occur if the same peak power is used for all EMOs, due to the first roll-off point P(1) of the EMO = 6 mask lying outside the envelope of the EMO = 2 and EMO = 4 masks. However, the less stringent masks do not need to be further relaxed because the overlapping condition is unlikely to occur in deployed mixed-mode systems, for the following reasons:

- 1) There is a significant power drop with higher modulation orders (due to power amplifier back off) that automatically "solves" the overlapping problem, as shown in figure F.1.
- 2) For frequency coordination purposes, a mixed-mode system will not be worse than a single-mode system employing the lowest licensed EMO.

An example is shown in figure F.1, where the output powers of the actual higher modulation orders are increased slightly to optimize service, but are always maintained at a sufficient margin below the absolute EMO = 2 (e.g. 4 QAM) power so that all portions of their spectrum masks remain below the lowest EMO = 2 Tx spectrum mask.

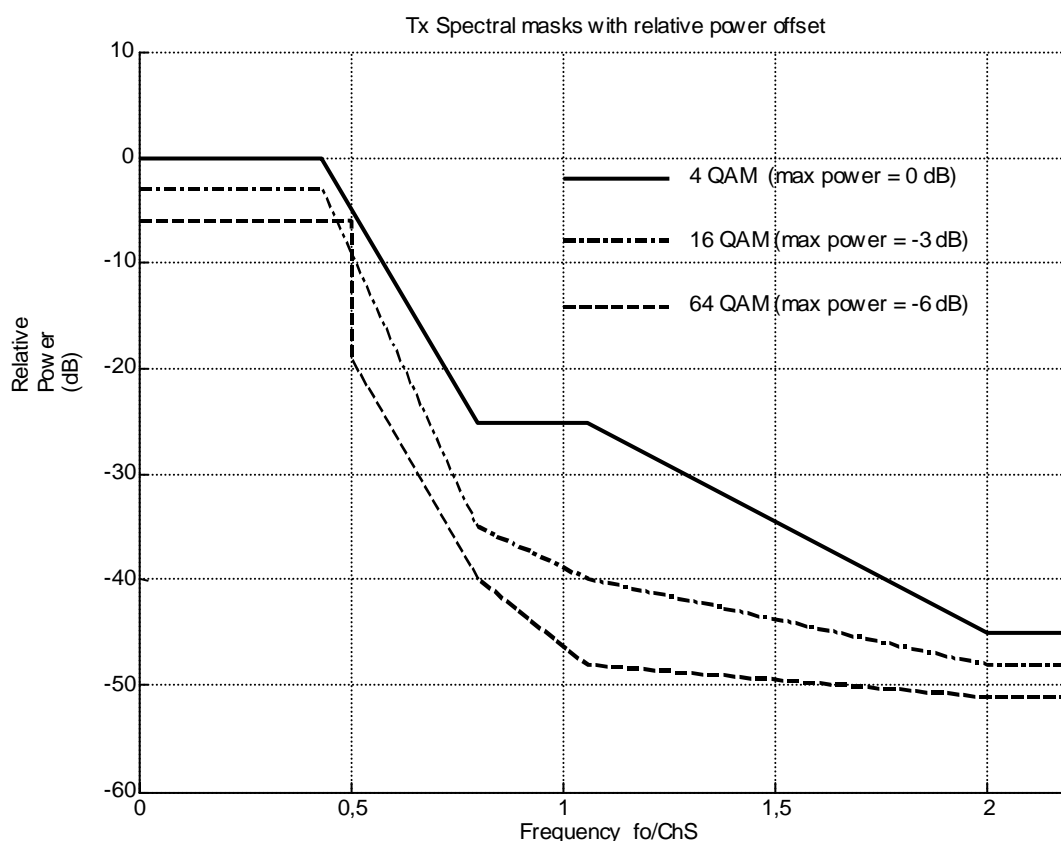

Figure F.1: Tx spectral masks of 16 QAM and 64 QAM with powers adjusted to remain below the 4 QAM mask

F.5.3 Adjacent channel interference

In order to achieve satisfactory spectrum utilization within the frequency range (block) assigned to the Operator, particularly where the capacity of a cell is increased by the use of more than one channel per sector, mixed-mode systems should be required to operate in adjacent channels over the same physical link in precisely the same way that single-mode systems are required to operate. It thus follows that a mixed-mode system should be required, for each actual modulation order used, to meet the related EMO (or manufacturer's defined) adjacent channel performance specification, with all combinations of interfering actual modulation order (including training bursts).

For example, in a mixed-mode TDMA system offering QAM states of 4, 16 and 64 (EMO = 2, 4, and 6 respectively), a time slot which is operating at 64 QAM should meet the adjacent channel performance specification for 64 QAM with an adjacent channel interfering signal of 4 QAM, 16 QAM or 64 QAM. Similarly, a timeslot which is operating at 4 QAM should meet the adjacent performance specification for 4 QAM with an adjacent channel interfering signal of 4 QAM, 16 QAM or 64 QAM.

F.5.4 Co-channel interference

Co-channel interference will occur where the interfering and victim systems are geographically separated or operating on different sectors. In both cases it is extremely unlikely (and spectrally inefficient) that the TDMA frames of the two systems would be synchronized and that the timeslots within each system's frames would operate on identical modulation orders. It therefore follows that the co-channel specification for each victim modulation order offered should be met with an interfering signal of any modulation order offered (including training bursts), in the same way as for adjacent channel performance. However, unlike the adjacent channel case, the co-channel interference performance would not generally depend on the interfering transmitter modulation.

Annex G (informative): Application of this multi-part standard

This annex describes the process whereby this multi-part standard may be applied to an equipment, antenna or equipment with integral antenna.

Step A: Determine whether the equipment, antenna or integrated equipment and antenna falls within the scope of the present document. Clause 1 defines the scope of the present document. Equipment, antennas or equipment with integrated antennas that do not fall within the scope of the present document may neither claim compliance with the present document nor use the standard as the sole route to demonstrate compliance with the essential requirements of the R&TTE Directive.

Does the equipment, antenna or equipment with integral antenna fall completely within the scope of the present document?

Yes: Proceed.

No: The present document may not be applied.

Step B: Determine whether the objective of assessment of equipment, antenna or equipment with integral antenna is to present evidence of fulfilling the essential requirements of the R&TTE Directive only or whether, additionally, to claim full compliance with the present document. Only a subset of the requirements of the present document (identified in clause 6 as "essential" and contained in EN 302 326-2 [6] and EN 302 326-3 [7]) need be met in order to present evidence of fulfilment of the R&TTE Directive essential requirements. All of the normative requirements of the present document are required to be met in order to claim full compliance with the present document, both those identified as "essential" in clause 6 and those identified as "complementary" in clauses 7 and 6.4.3.

Is the equipment, antenna or equipment with integral antenna required to fulfil the essential requirements of the R&TTE Directive?

Yes: The requirements identified as "essential" in clause 6 and contained in EN 302 326-2 [6] and EN 302 326-3 [7] must be met.

No: The present document may not be relevant to the equipment or its proposed use. It may not be appropriate to proceed.

Additionally, is full compliance with the present document to be claimed?

Yes: All normative requirements of the present document must be met, both those identified as "essential" in clause 6 and those identified as "complementary" and contained in clauses 7 and 6.4.3.

No: Only the requirements described as "essential" in clause 6 need be met.

Step C: Is compliance sought for an equipment with integral antenna?

Does the equipment have an integral antenna?

Yes: The requirements of the present document for equipment and antennas must both be met.

No: Only the requirements of the present document for an equipment or an antenna (as appropriate) need be met.

Step D: Determine what equipment or antenna profile is applicable to the equipment, antenna or equipment with integral antenna. The present document is applicable to equipment and antennas of various types, channel spacings, frequency ranges etc. Equipment may be classified with an EqC (Equipment Classification) according to the principles of annex A of the present document. A number of parameters have values which depend on the particular type, channel spacing and frequency range etc. However, not all combinations (described as "equipment profiles") of types and ranges are permissible and, for a given profile, all parameters for that combination must be met. It is not permissible, for example, to "pick and mix" values for different parameters from different profiles. Certain fields within the equipment profile are described by letters. Although these letters are derived from earlier standards specific to particular access methods, it is not necessary that an equipment should employ any specific access technology, only that the profile selected is within the list of combinations permitted in the present document and that all parameters appropriate to the selected profile are met. Annex A of the present document describes the format of the equipment profiles and the description of the fields. Clause 6.1 defines the permitted profiles of equipment, antennas and systems.

Is there a profile in clause 6.1 which is applicable to the equipment, antenna or equipment with integral antenna?

Yes: Select this profile and proceed.

No: The present document may not be applied: apply an alternative standard or, after consultation with a Notified Body, an alternative route for R&TTE Directive compliance.

Step E: Determine the appropriate reference point for traffic stream related parameters. A number of parameters are related to the traffic stream through the equipment, such as bit rate and bit error ratio. Depending on functionality within the equipment, the physical user data interfaces to the equipment may not be the appropriate reference points for these parameters. In this case, it is open to the manufacturer to define a reference point for these parameters within his or her equipment. Annex E of the present document gives guidance, which may assist in the selection of this reference point.

Define the reference point for traffic stream related parameters.

Step F: Select an environmental profile. Equipment, antennas and equipment with integral antennas must operate within an environmental profile. If the equipment, antenna or equipment with integral antenna is only required to present evidence of fulfilling the essential requirements of the R&TTE Directive (see Step B), then the manufacturer may declare the environmental profile within which the equipment, antenna or equipment with integral antenna will comply with the standard. If full compliance with the present document is sought, the equipment, antenna or equipment with integral antenna must comply with the present document within an environmental profile defined in clause 6.3.

Is the equipment, antenna or equipment with integral antenna **only** required to fulfil the essential requirements of the R&TTE Directive?

Yes: An environmental profile for the equipment, antenna or equipment with integral antenna must be defined by the manufacturer.

Additionally, is full compliance with the present document to be claimed?

Yes: The equipment, antenna or equipment with integral antenna must comply with clause 6.3.

Step G: Assess conformance with the relevant clauses of the present document. Given the choice of required level of compliance from step B and the choice of profile from step D, identify all normative clauses and table entries in the present document that are applicable to the selected level of compliance and profile. The test houses which perform the tests for essential requirements on the equipment, antenna or equipment with integral antenna will use the conformance test methods specified in clause 6 of EN 302 326-2 [6] and clause 5 of EN 302 326-3 [7]. It is advised that manufacturers use these or equivalent test methods to perform in-house pre-assessment of their equipment, antenna or equipment with integral antenna.

Assess the conformance of equipment, antenna or equipment with integral antenna to the clauses in this multi-part standard applicable to the level of compliance selected at step B and the profile selected at step D.

NOTE: If assessment of the equipment, antenna or equipment with integral antenna is such that it may not conform to the standard with the selected level of compliance from step B, the choice of profile from step D, the traffic stream reference point from step E and the environmental profile from step F, it may be appropriate to return to step B and make alternative choices.

Annex H (informative): Notification of Interfaces under article 4.1 of the R&TTE Directive

This informative annex provides in table H.1 explanations on the applicability of the TCAM-RIG format to the notification of the regulated Fixed Links Interfaces by the Administrations. Table H.2 gives an illustrative example of such a notification for MP application. This annex has been elaborated in co-ordination with the CEPT ECC WG SE.

NOTE: In table H.1, the text "(ref EN)" is intended as the suitable reference(s) to the EN relevant for the specific case under consideration by the Administration producing the Notification.

H.1 Applicability of TCAM-RIG format of Radio interface specifications to Fixed Services

Table H.1: Applicability of TCAM-RIG format of Radio interface specifications to Fixed Services

Nr.	TCAM-RIG proposed parameter	CEPT ECC WGSE conclusions on applicability to FS
1	Frequency band	Applicable, for FS should mean limits of allocated band, which e.g. may include guard bands of the channel plan and duplex centre gap
2	Radio service (some countries put this only in a separate allocation table)	Applicable, should be set to "Fixed Service" in this case
3	Application	Applicable, for FS should specify whether this frequency band is assigned for PP, PMP, MPMP; for infrastructure, access or other, or combination
4	Channelling/modulation	Channelling only - the channelling arrangements should be specified, e.g. ref. to CEPT/ITU recommendation/annex and/or National (the latter to be explained or attached). National restrictions/modifications to CEPT/ITU plans to be described. Modulation for FS is technology specific, so should not be mentioned as a requirement, but suitable modulations may be derived from channel arrangements/EN classes, see also "Channel occupation rules"
5	Transmit power limit	Applicable, depends on type of FS application, etc. Actual meaning (output power and/or EIRP) may vary
6	Channel occupation rules	Applicable in some cases (not for block assignments), may mean transmission capacity, minimum hop length, etc.
7	Duplex direction/separation	Applicable, for FS should read "Duplex type/spacing", in some cases reference to the specified channel arrangement may be sufficient, in other - should be explained, for FDD MP systems the uplink/downlink bands could be specified
8	Licensing regime	Applicable, for FS could be Individual licence, block assignment, general licence. Other peculiarities should be mentioned if any (e.g. geographical limitations)
9	Additional essential requirements (article 3.3)	Not applicable for FS for the time being
10	Frequency planning assumptions	Applicable, for FS could be expanded into: Antenna radiation pattern (ref EN), Emission spectrum mask (ref EN), Receiver parameters (ref EN) Minimum antenna gain, ATPC
11	Reference	Applicable
12	Remarks	Applicable
13	Notification number (might help to trace back to the notification procedure and it is a requirement to give this reference number in the published regulation).	Applicable

H.2 Proposed list of radio interface specifications for Fixed Services

It should be noted that the proposed below list of radio interface specifications should be used in the framework of R&TTE Directive [1] that is when deciding on eligibility of FS equipment to be placed on the market and brought into service.

The list of parameters that are relevant to national spectrum management functions (e.g. for frequency assignment process) is wider/different, as e.g. described in ECC/REC 01-05 (see bibliography). Administrations may request those parameters from the applicant/licensee during the licensing procedure.

It is understood that the proposed FS radio interface requirements provide a list of parameters, allowing individual Administrations to select those parameters necessary to the case, depending on the information in the European harmonized standards and the level of detail in their national frequency allocation tables.

Table H.2 contains an example tailored to a MP band notification.

Table H.2: Example of Notification for MP Fixed Links

Parameter	Value [examples]	Filling instructions
Frequency band (GHz)	[24,5 to 26,5] or [24,549 to 24,773 paired with 25,557 to 25,781]	Limits of FS allocated band or relevant segmentation applicable to the notification (the example assumes that only the first 8x28 MHz paired channels of the channel arrangement are used for MP)
Radio service	Fixed Service	
Application/ System type	[Access] [PMP]	Infrastructure, access or other, or combination, etc; PP, PMP, MPMP
Channelling	[ERC/REC T/R13-02 annex B] [28 MHz channels only]	Either reference to CEPT/ITU recommendation/annex and/or National plan (the latter to be explained or attached). National restrictions/modifications to CEPT/ITU plans to be described
Transmit power limit	[XX dBm EIRP]	Should be specified whether it is an output power and/or EIRP; in accordance with RR provisions. For block assignment it may be complemented by additional provisions (e.g. border PFD limits)
Channel occupation rules	[equipment type(s) (type x, y) in accordance with EN 301 213-X]	May mean transmission capacity (possibly linked to channel width) (Ref EN equipment type), equipment class, etc. Any geographical and spectrum efficiency requirements might be described
Duplex type/spacing	[FDD] [ERC/REC T/R13-02 annex B; ERC/REC 00-05]	FDD, TDD Either reference to the specified channel arrangement or explained, for FDD MP systems the uplink/downlink bands could be specified
Licensing regime	[Blocks of Nx28 MHz basic channels; ERC/REC 00-05]	Could be Individual assignment, block assignment, and general licence. Other specifics should be mentioned, if any (e.g. geographical limitations)
Frequency planning assumptions	[ATPC: XX dB]	Could include requirements in accordance with articles 3.2 and 7.2 of the R&TTE: Antenna radiation pattern (ref EN), Emission spectrum mask (ref EN), Receiver parameters (ref EN), Minimum antenna gain, ATPC. Note that, in MP applications, actual frequency planning is generally made (cell-by-cell) by the licensed Operator. Here the term is intended from the regulatory point of view only, therefore other provisions are applicable e.g.: For block assignment specific provisions may be set (usage/implementation of relevant ECC-Recs for FWA, PFD masks/limits, inter-operator co-ordination procedures, block edge mask, etc.) and reference to national specific documentation, if any, should be explicitly mentioned here
Reference	[EN 301 753]	Reference to harmonized standard, selected equipment type/class, etc.
Remarks		Any relevant remarks, additional info
Notification number		For administrative reference purposes
NOTE: References in the table are found in bibliography.		

Annex I (informative): Bibliography

CENELEC EN 122 150: "Sectional Specification: Radio frequency coaxial connectors - Series EIA flange".

CEPT/ERC/DEC(00)09: "ERC Decision of 19 October 2000 on the use of the band 27.5 GHz to 29.5 GHz by the fixed service and uncoordinated Earth stations of the fixed-satellite service (Earth-to-space)".

CEPT/ERC/REC 00-05: "Use of the band 24.5 - 26.5 GHz for fixed wireless access".

CEPT/ERC/REC 01-02: "Preferred channel arrangement for digital fixed service systems operating in the frequency band 31.8 - 33.4 GHz".

CEPT/ERC/REC 01-03: "Use of parts of the band 27.5 - 29.5 GHz for Fixed Wireless Access (FWA)".

CEPT/ECC/REC 01-05: "List of parameters of digital point-to-point fixed radio links used for national planning".

CEPT/ECC/REC 02-02: "Channel arrangements for digital fixed service systems (point-to-point and point-to-multipoint) operating in the frequency band 31 - 31.3 GHz".

CEPT/ERC/REC 13-04: "Preferred frequency bands for fixed wireless access in the frequency range between 3 and 29.5 GHz".

CEPT/ERC/REC 12-05: "Harmonized radio frequency channel arrangements for digital terrestrial fixed systems operating in the band 10.0 - 10.68 GHz".

CEPT/ERC/REC 12-08: "Harmonized radio frequency channel arrangements and block allocations for low, medium and high capacity systems in the band 3 600 MHz to 4 200 MHz".

CEPT/ERC/REC T/R 13-02: "Preferred channel arrangements for the fixed services in the range 22.0 - 29.5 GHz".

CEPT/ERC/REC 14-03: "Harmonized radio frequency channel arrangements for low and medium capacity systems in the band 3 400 MHz to 3 600 MHz".

CEPT/ERC Report 25: "The European table of frequency allocations and utilizations covering the frequency range 9 kHz to 275 GHz".

CORDIS COST Project 207: "Digital Land Mobile Radiocommunications".

Directive 95/54/EC concerning the adaptation to technical progress of Council Directive 72/245/EEC and amending Directive 70/156/EEC relating to the type-approval of motor vehicles and their trailers: OJ L 266, 1995.

ETSI EG 202 306 (V1.2.1): "Transmission and Multiplexing (TM); Access networks for residential customers".

ETSI EN 300 636: "Fixed Radio Systems; Point-to-multipoint equipment; Time Division Multiple Access (TDMA); Point-to-multipoint digital radio systems in frequency bands in the range 1 GHz to 3 GHz".

ETSI EN 301 021: "Fixed Radio Systems; Point-to-multipoint equipment; Time Division Multiple Access (TDMA); Point-to-multipoint digital radio systems in frequency bands in the range 3 GHz to 11 GHz".

ETSI EN 301 055: "Fixed Radio Systems; Point-to-multipoint equipment; Direct Sequence Code Division Multiple Access (DS-SS); Point-to-multipoint digital radio systems in frequency bands in the range 1 GHz to 3 GHz".

ETSI EN 301 080: "Fixed Radio Systems; Point-to-multipoint equipment; Frequency Division Multiple Access (FDMA); Point-to-multipoint digital radio systems in frequency bands in the range 3 GHz to 11 GHz".

ETSI EN 301 124: "Fixed Radio Systems; Point-to-multipoint equipment; Direct Sequence Code Division Multiple Access (DS-SS) point-to-multipoint digital radio systems in frequency bands in the range 3 GHz to 11 GHz".

ETSI EN 301 179: "Fixed Radio Systems; Point-to-multipoint equipment; Frequency Hopping Code Division Multiple Access (FH-SS); Point-to-multipoint Digital Radio Relay Systems (DRRS) in the bands within the range 1 GHz to 3 GHz".

ETSI EN 301 213-1: "Fixed Radio Systems; Point-to-multipoint equipment; Point-to-multipoint digital radio systems in frequency bands in the range 24,25 GHz to 29,5 GHz using different access methods; Part 1: Basic parameters".

ETSI EN 301 213-2: "Fixed Radio Systems; Point-to-multipoint equipment; Point-to-multipoint digital radio systems in frequency bands in the range 24,25 GHz to 29,5 GHz using different access methods; Part 2: Frequency Division Multiple Access (FDMA) methods".

ETSI EN 301 213-3: "Fixed Radio Systems; Point-to-multipoint equipment; Point-to-multipoint digital radio systems in frequency bands in the range 24,25 GHz to 29,5 GHz using different access methods; Part 3: Time Division Multiple Access (TDMA) methods".

ETSI EN 301 213-4: "Fixed Radio Systems; Point-to-multipoint equipment; Point-to-multipoint digital radio systems in frequency bands in the range 24,25 GHz to 29,5 GHz using different access methods; Part 4: Direct Sequence Code Division Multiple Access (DS-CDMA) methods".

ETSI EN 301 213-5: "Fixed Radio Systems; Point-to-multipoint equipment; Point-to-multipoint digital radio systems in frequency bands in the range 24,25 GHz to 29,5 GHz using different access methods; Part 5: Multi-Carrier Time Division Multiple Access (MC-TDMA) methods".

ETSI EN 301 215-1: "Fixed Radio Systems; Point to Multipoint Antennas; Antennas for point-to-multipoint fixed radio systems in the 11 GHz to 60 GHz band; Part 1: General aspects".

ETSI EN 301 215-2: "Fixed Radio Systems; Point-to-Multipoint Antennas; Antennas for point-to-multipoint fixed radio systems in the 11 GHz to 60 GHz band; Part 2: 24 GHz to 30 GHz".

ETSI EN 301 215-3: "Fixed Radio Systems; Point to Multipoint Antennas; Antennas for point-to-multipoint fixed radio systems in the 11 GHz to 60 GHz band; Part 3: Multipoint Multimedia Wireless system in 40,5 GHz to 43,5 GHz".

ETSI EN 301 215-4: "Fixed Radio Systems; Point-to-Multipoint Antennas; Antennas for multipoint fixed radio systems in the 11 GHz to 60 GHz band; Part 4: 30 GHz to 40,5 GHz".

ETSI EN 301 253: "Fixed Radio Systems; Point-to-multipoint equipment; Frequency Hopping Code Division Multiple Access (FH-CDMA); Point-to-multipoint digital radio systems in frequency bands in the range 3 GHz to 11 GHz".

ETSI EN 301 373: "Fixed Radio Systems; Point-to-multipoint equipment; Frequency Division Multiple Access (FDMA); Point-to-multipoint digital radio systems in frequency bands in the range 1 GHz to 3 GHz".

ETSI EN 301 460-1: "Fixed Radio Systems; Point-to-multipoint equipment; Part 1: Point-to-multipoint digital radio systems below 1 GHz - Common parameters".

ETSI EN 301 460-2: "Fixed Radio Systems; Point-to-multipoint equipment; Part 2: Point-to-multipoint digital radio systems below 1 GHz - Additional parameters for TDMA systems".

ETSI EN 301 460-3: "Fixed Radio Systems; Point-to-multipoint equipment; Part 3: Point-to-multipoint digital radio systems below 1 GHz - Additional parameters for FH-CDMA systems".

ETSI EN 301 460-4: "Fixed Radio Systems; Point-to-multipoint equipment; Part 4: Point-to-multipoint digital radio systems below 1 GHz - Additional parameters for FDMA systems".

ETSI EN 301 460-5: "Fixed Radio Systems; Point-to-multipoint equipment; Part 5: Point-to-multipoint digital radio systems below 1 GHz - Additional Parameters for DS-CDMA Systems".

ETSI EN 301 525: "Fixed Radio Systems; Point-to-Multipoint Antennas; Antennas for Point-to-Multipoint fixed radio systems in the 1 GHz to 3 GHz band".

ETSI EN 301 753: "Fixed Radio Systems; Multipoint equipment and antennas; Generic harmonized standard for multipoint digital fixed radio systems and antennas covering the essential requirements under article 3.2 of the Directive 1999/5/EC".

ETSI EN 301 997: "Transmission and Multiplexing (TM); Multipoint equipment; Radio equipment for use in Multimedia Wireless Systems (MWS) in the frequency band 40,5 GHz to 43,5 GHz".

ETSI EN 302 063: "Fixed Radio Systems; Multipoint equipment; Multipoint digital radio systems operating in the 31,0 GHz to 33,4 GHz (32 GHz) frequency range".

ETSI EN 302 078: "Fixed Radio Systems; Multipoint antennas; Circularly polarized antennas for multipoint fixed radio systems in the 1 GHz to 11 GHz band".

ETSI EN 302 085: "Fixed Radio Systems; Point-to-Multipoint Antennas; Antennas for point-to-multipoint fixed radio systems in the 3 GHz to 11 GHz band".

ETSI TR 101 274: "Transmission and Multiplexing (TM); Digital Radio Relay Systems (DRRS); Point-to-multipoint DRRS in the access network: Overview of different access techniques".

IEC 60169-1: "Radio-frequency connectors - Part 1: General requirements and measuring methods".

IEC 60339-1: "General purpose rigid coaxial transmission lines and their associated flange connectors - Part 1: General requirements and measuring methods".

IEC 60339-2: "General purpose rigid coaxial transmission lines and their associated flange connectors - Part 2: Detail specifications".

ITU-R Recommendation P.372: "Radio noise".

ITU-T Recommendation G.131: "Talker echo and its control".

ITU-T Recommendation G.711: "Pulse code modulation (PCM) of voice frequencies".

ITU-T Recommendation G.723.1: "Speech coders: Dual rate speech coder for multimedia communications transmitting at 5,3 and 6,3 kbit/s".

ITU-T Recommendation G.726: "40, 32, 24, 16 kbit/s adaptive differential pulse code modulation (ADPCM)".

ITU-T Recommendation G.728: "Coding of speech at 16 kbit/s using low-delay code excited linear prediction".

ITU-T Recommendation G.729: "Coding of speech at 8 kbit/s using conjugate-structure algebraic-code-excited linear-prediction (CS-ACELP)".

ITU-T Recommendation G.810: "Definitions and terminology for synchronization networks".

ITU-T Recommendation G.812: "Timing requirements of slave clocks suitable for use as node clocks in synchronization networks".

ITU-T Recommendation G.813: "Timing characteristics of SDH equipment slave clocks (SEC)".

ITU-T Recommendation G.823: "The control of jitter and wander within digital networks which are based on the 2 048 kbit/s hierarchy".

ITU-T Recommendation G.825: "The control of jitter and wander within digital networks which are based on the synchronous digital hierarchy (SDH)".

History

Document history		
V1.1.1	March 2005	Public Enquiry PE 20050701: 2005-03-02 to 2005-07-01
V1.1.1	October 2005	Vote V 20051216: 2005-10-17 to 2005-12-16
V1.1.1	December 2005	Publication