

ETSI EN 302 307 V1.2.1 (2009-08)

European Standard (Telecommunications series)

**Digital Video Broadcasting (DVB);
Second generation framing structure, channel coding and
modulation systems for Broadcasting,
Interactive Services, News Gathering and
other broadband satellite applications (DVB-S2)**



Reference

REN/JTC-DVB-238

Keywords

BSS, digital, DVB, modulation, satellite, TV

ETSI

650 Route des Lucioles
F-06921 Sophia Antipolis Cedex - FRANCE

Tel.: +33 4 92 94 42 00 Fax: +33 4 93 65 47 16

Siret N° 348 623 562 00017 - NAF 742 C
Association à but non lucratif enregistrée à la
Sous-Préfecture de Grasse (06) N° 7803/88

Important notice

Individual copies of the present document can be downloaded from:

<http://www.etsi.org>

The present document may be made available in more than one electronic version or in print. In any case of existing or perceived difference in contents between such versions, the reference version is the Portable Document Format (PDF). In case of dispute, the reference shall be the printing on ETSI printers of the PDF version kept on a specific network drive within ETSI Secretariat.

Users of the present document should be aware that the document may be subject to revision or change of status. Information on the current status of this and other ETSI documents is available at

<http://portal.etsi.org/tb/status/status.asp>

If you find errors in the present document, please send your comment to one of the following services:

http://portal.etsi.org/chaicor/ETSI_support.asp

Copyright Notification

No part may be reproduced except as authorized by written permission.
The copyright and the foregoing restriction extend to reproduction in all media.

© European Telecommunications Standards Institute 2009.

© European Broadcasting Union 2009.

All rights reserved.

DECTTM, **PLUGTESTS**TM, **UMTS**TM, **TIPHON**TM, the TIPHON logo and the ETSI logo are Trade Marks of ETSI registered for the benefit of its Members.

3GPPTM is a Trade Mark of ETSI registered for the benefit of its Members and of the 3GPP Organizational Partners.

LTETM is a Trade Mark of ETSI currently being registered for the benefit of its Members and of the 3GPP Organizational Partners.

GSM[®] and the GSM logo are Trade Marks registered and owned by the GSM Association.

Contents

Intellectual Property Rights	5
Foreword.....	5
1 Scope	6
2 References	8
2.1 Normative references	8
2.2 Informative references.....	9
3 Symbols and abbreviations.....	9
3.1 Symbols.....	9
3.2 Abbreviations	10
4 Transmission system description.....	12
4.1 System definition.....	12
4.2 System architecture	12
4.3 System configurations	13
5 Subsystems specification.....	14
5.1 Mode adaptation.....	14
5.1.1 Input interface.....	14
5.1.2 Input stream synchronizer (optional, not relevant for single TS - BS)	15
5.1.3 Null-Packet Deletion (ACM and Transport Stream only)	15
5.1.4 CRC-8 encoder (for packetized streams only).....	16
5.1.5 Merger/Slicer	16
5.1.6 Base-Band Header insertion	17
5.2 Stream adaptation	19
5.2.1 Padding	19
5.2.2 BB scrambling	19
5.3 FEC encoding.....	20
5.3.1 Outer encoding (BCH).....	21
5.3.2 Inner encoding (LDPC)	22
5.3.2.1 Inner coding for normal FECFRAME.....	22
5.3.2.2 Inner coding for short FECFRAME.....	23
5.3.3 Bit Interleaver (for 8PSK, 16APSK and 32APSK only).....	24
5.4 Bit mapping into constellation.....	25
5.4.1 Bit mapping into QPSK constellation.....	25
5.4.2 Bit mapping into 8PSK constellation.....	26
5.4.3 Bit mapping into 16APSK constellation.....	26
5.4.4 Bit mapping into 32APSK	27
5.5 Physical Layer (PL) framing	28
5.5.1 Dummy PLFRAME insertion	29
5.5.2 PL signalling	29
5.5.2.1 SOF field.....	30
5.5.2.2 MODCOD field.....	30
5.5.2.3 TYPE field	30
5.5.2.4 PLS code	30
5.5.3 Pilots insertion	31
5.5.4 Physical layer scrambling	31
5.6 Baseband shaping and quadrature modulation	33
6 Error performance	34
Annex A (normative): Signal spectrum at the modulator output.....	35
Annex B (normative): Addresses of parity bit accumulators for $n_{ldpc} = 64\ 800$.....	37
Annex C (normative): Addresses of parity bit accumulators for $n_{ldpc} = 16\ 200$.....	47

Annex D (normative):	Additional Mode Adaptation and ACM tools	50
D.1	"ACM Command" signalling interface	50
D.2	Input stream synchronizer	50
D.3	Null-packet Deletion (normative for input transport streams and ACM).....	52
D.4	BBHEADER and Merging/slicing Policy for various application areas.....	53
D.5	Signalling of reception quality via return channel (Normative for ACM).....	54
Annex E (normative):	SI and signal identification for DSNG and contribution applications	56
Annex F (normative):	Backwards Compatible modes (optional).....	57
Annex G (informative):	Supplementary information on receiver implementation	60
G.1	Carrier recovery.....	60
G.2	FEC decoding.....	60
G.3	ACM: Transport Stream regeneration and clock recovery using ISCR	63
G.4	Non linearity pre-compensation and Intersymbol Interference suppression techniques	63
G.5	Interactive services using DVB-RCS return link: user terminal synchronization.....	64
Annex H (informative):	Examples of possible use of the System.....	65
H.1	CCM digital TV broadcasting: bit rate capacity and C/N requirements	65
H.2	Distribution of multiple TS multiplexes to DTT Transmitters (Multiple TS, CCM).....	67
H.3	SDTV and HDTV broadcasting with differentiated protection (VCM, Multiple TS)	68
H.4	DSNG Services using ACM (Single transport Stream, information rate varying in time)	68
H.5	IP Unicast Services (Non-uniform protection on a user-by-user basis)	69
H.6	Example performance of BC modes.....	71
H.7	Satellite transponder models for simulations	72
H.8	Phase noise masks for simulations	74
Annex I (normative):	Mode Adaptation input interfaces (optional)	75
I.1	Mode Adaptation input interface with separate signalling circuit (optional).....	75
I.2	Mode Adaptation input interface with in-band signalling (optional).....	76
Annex J (informative):	Bibliography.....	77
History	78

Intellectual Property Rights

IPRs essential or potentially essential to the present document may have been declared to ETSI. The information pertaining to these essential IPRs, if any, is publicly available for **ETSI members and non-members**, and can be found in ETSI SR 000 314: "*Intellectual Property Rights (IPRs); Essential, or potentially Essential, IPRs notified to ETSI in respect of ETSI standards*", which is available from the ETSI Secretariat. Latest updates are available on the ETSI Web server (<http://webapp.etsi.org/IPR/home.asp>).

Pursuant to the ETSI IPR Policy, no investigation, including IPR searches, has been carried out by ETSI. No guarantee can be given as to the existence of other IPRs not referenced in ETSI SR 000 314 (or the updates on the ETSI Web server) which are, or may be, or may become, essential to the present document.

Foreword

This European Standard (Telecommunications series) has been produced by Joint Technical Committee (JTC) Broadcast of the European Broadcasting Union (EBU), Comité Européen de Normalisation ELECtrotechnique (CENELEC) and the European Telecommunications Standards Institute (ETSI).

The work of the JTC was based on the studies carried out by the European DVB Project under the auspices of the Ad Hoc Group on DVB-S2 of the DVB Technical Module. This joint group of industry, operators and broadcasters provided the necessary information on all relevant technical matters (see bibliography).

NOTE: The EBU/ETSI JTC Broadcast was established in 1990 to co-ordinate the drafting of standards in the specific field of broadcasting and related fields. Since 1995 the JTC Broadcast became a tripartite body by including in the Memorandum of Understanding also CENELEC, which is responsible for the standardization of radio and television receivers. The EBU is a professional association of broadcasting organizations whose work includes the co-ordination of its members' activities in the technical, legal, programme-making and programme-exchange domains. The EBU has active members in about 60 countries in the European broadcasting area; its headquarters is in Geneva.

European Broadcasting Union
CH-1218 GRAND SACONNEX (Geneva)
Switzerland
Tel: +41 22 717 21 11
Fax: +41 22 717 24 81

Founded in September 1993, the DVB Project is a market-led consortium of public and private sector organizations in the television industry. Its aim is to establish the framework for the introduction of MPEG-2 based digital television services. Now comprising over 200 organizations from more than 25 countries around the world, DVB fosters market-led systems, which meet the real needs, and economic circumstances, of the consumer electronics and the broadcast industry.

National transposition dates

Date of adoption of this EN:	24 August 2009
Date of latest announcement of this EN (doa):	30 November 2009
Date of latest publication of new National Standard or endorsement of this EN (dop/e):	31 May 2010
Date of withdrawal of any conflicting National Standard (dow):	31 May 2010

1 Scope

DVB-S (EN 300 421 [2]) was introduced as a standard in 1994 and DVB-DSNG (EN 301 210 [3]) in 1997. The DVB-S standard specifies QPSK modulation and concatenated convolutional and Reed-Solomon channel coding, and is now used by most satellite operators worldwide for television and data broadcasting services. DVB-DSNG specifies, in addition to DVB-S format, the use of 8PSK and 16QAM modulation for satellite news gathering and contribution services.

Since 1997, digital satellite transmission technology has evolved somewhat:

- New channel coding schemes, combined with higher order modulation, promise more powerful alternatives to the DVB-S/DVB-DSNG coding and modulation schemes. The result is a capacity gain in the order of 30 % at a given transponder bandwidth and transmitted EIRP, depending on the modulation type and code rate.
- Variable Coding and Modulation (VCM) may be applied to provide different levels of error protection to different service components (e.g. SDTV and HDTV, audio, multimedia).
- In the case of interactive and point-to-point applications, the VCM functionality may be combined with the use of return channels, to achieve Adaptive Coding and Modulation (ACM). This technique provides more exact channel protection and dynamic link adaptation to propagation conditions, targeting each individual receiving terminal. ACM systems promise satellite capacity gains of up to 100 % - 200 %. In addition, service availability may be extended compared to a constant protection system (CCM) such as DVB-S or DVB-DSNG. Such gains are achieved by informing the satellite up-link station of the channel condition (e.g. C/N+I) of each receiving terminal via the satellite or terrestrial return channels.
- DVB-S and DVB-DSNG are strictly focused on a unique data format, the MPEG Transport Stream (ISO/IEC 13818-1 [1] or a reference to it). Extended flexibility to cope with other input data formats (such as multiple Transport Streams, or generic data formats) is now possible without significant complexity increase.

The present document defines a "second generation" modulation and channel coding system (denoted the "System" or "DVB-S2" for the purposes of the present document) to make use of the improvements listed above. DVB-S2 is a single, very flexible standard, covering a variety of applications by satellite, as described below. It is characterized by:

- a flexible input stream adapter, suitable for operation with single and multiple input streams of various formats (packetized or continuous);
- a powerful FEC system based on LDPC (Low-Density Parity Check) codes concatenated with BCH codes, allowing Quasi-Error-Free operation at about 0,7 dB to 1 dB from the Shannon limit, depending on the transmission mode (AWGN channel, modulation constrained Shannon limit);
- a wide range of code rates (from 1/4 up to 9/10); 4 constellations, ranging in spectrum efficiency from 2 bit/s/Hz to 5 bit/s/Hz, optimized for operation over non-linear transponders;
- a set of three spectrum shapes with roll-off factors 0,35, 0,25 and 0,20;
- Adaptive Coding and Modulation (ACM) functionality, optimizing channel coding and modulation on a frame-by-frame basis.

The System has been optimized for the following **broadband satellite applications**:

Broadcast Services (BS) Digital multi-programme Television (TV)/High Definition Television (HDTV)

Broadcasting services to be used for primary and secondary distribution in the Fixed Satellite Service (FSS) and the Broadcast Satellite Service (BSS) bands.

DVB-S2 is intended to provide Direct-To-Home (DTH) services for consumer Integrated Receiver Decoder (IRD), as well as collective antenna systems (Satellite Master Antenna Television - SMATV) and cable television head-end stations (possibly with remodulation, see EN 300 429 [5]). DVB-S2 may be considered a successor to the current DVB-S standard EN 300 421 [2], and may be introduced for new services and allow for a long-term migration. BS services are transported in MPEG Transport Stream format. VCM may be applied on multiple transport stream to achieve a differentiated error protection for different services (TV, HDTV, audio, multimedia). Two modes are available:

- **NBC-BS** (Non Backwards Compatible Broadcast Services) is not backwards-compatible with EN 300 421 [2].
- **BC-BS** (Backwards-Compatible Broadcast Services) is backwards-compatible to EN 300 421 [2] (see annex F).

In fact, with a large number of DVB-S receivers already installed, backwards compatibility may be required for a period of time, where old receivers continue to receive the same capacity as before, while the new DVB-S2 receivers could receive additional capacity broadcasts. When the complete receiver population has migrated to DVB-S2, the transmitted signal can be modified to a non-backward compatible mode, thus exploiting the full potential of DVB-S2. To facilitate the reception of DVB-S services by DVB-S2 receivers, implementation of DVB-S in DVB-S2 chips is highly recommended.

Interactive Services (IS) Interactive data services including Internet access

DVB-S2 is intended to provide interactive services to consumer IRDs and to personal computers, where DVB-S2's forward path supersedes the current DVB-S standard EN 300 421 [2] for interactive systems. The return path can be implemented using various DVB interactive systems, such as DVB-RCS (EN 301 790 [6]), DVB-RCP (ETS 300 801 [7]), DVB-RCG (EN 301 195 [8]), DVB-RCC (ES 200 800 [9]). Data services are transported in (single or multiple) Transport Stream format according to EN 301 192 [4] (e.g. using Multiprotocol Encapsulation), or in (single or multiple) generic stream format. DVB-S2 can provide Constant Coding and Modulation (CCM), or Adaptive Coding and Modulation (ACM), where each individual satellite receiving station controls the protection mode of the traffic addressed to it. Input Stream Adaptation for ACM is specified in annex D.

Digital TV Contribution and Satellite News Gathering (DTVC/DSNG)

Digital television contribution applications by satellite consist of point-to-point or point-to-multipoint transmissions, connecting fixed or transportable uplink and receiving stations. They are not intended for reception by the general public. According to ITU-R Recommendation SNG.770-1 [10], SNG is defined as "Temporary and occasional transmission with short notice of television or sound for broadcasting purposes, using highly portable or transportable uplink earth stations ...". Services are transported in single (or multiple) MPEG Transport Stream format. DVB-S2 can provide Constant Coding and Modulation (CCM), or Adaptive Coding and Modulation (ACM). In this latter case, a single satellite receiving station typically controls the protection mode of the full multiplex. Input Stream Adaptation for ACM is specified in annex D.

Data content distribution/trunking and other professional applications (PS)

These services are mainly point-to-point or point-to-multipoint, including interactive services to professional head-ends, which re-distribute services over other media. Services may be transported in (single or multiple) generic stream format. The system can provide Constant Coding and Modulation (CCM), Variable Coding and Modulation (VCM) or Adaptive Coding and Modulation (ACM). In this latter case, a single satellite receiving station typically controls the protection mode of the full TDM multiplex, or multiple receiving stations control the protection mode of the traffic addressed to each one. In either case, interactive or non-interactive, the present document is only concerned with the forward broadband channel.

DVB-S2 is suitable for use on different satellite transponder bandwidths and frequency bands. The symbol rate is matched to given transponder characteristics, and, in the case of multiple carriers per transponder (FDM), to the frequency plan adopted. Examples of possible DVB-S2 use are given in clause H.1.

Digital transmissions via satellite are affected by power and bandwidth limitations. Therefore DVB-S2 provides for many transmission modes (FEC coding and modulations), giving different trade-offs between power and spectrum efficiency (see clause H.1). For some specific applications (e.g. broadcasting) modes such as QPSK and 8PSK, with their quasi-constant envelope, are appropriate for operation with saturated satellite power amplifiers (in single carrier per transponder configuration). When higher power margins are available, spectrum efficiency can be further increased to reduce bit delivery cost. In these cases also 16APSK and 32APSK can operate in single carrier mode close to the satellite HPA saturation by pre-distortion techniques. All the modes are appropriate for operation in quasi-linear satellite channels, in multi-carrier Frequency Division Multiplex (FDM) type applications.

DVB-S2 is compatible with Moving Pictures Experts Group (MPEG-2 and MPEG-4) coded TV services (see ISO/IEC 13818-1 [1]), with a Transport Stream packet multiplex. Multiplex flexibility allows the use of the transmission capacity for a variety of TV service configurations, including sound and data services. All service components are Time Division Multiplexed (TDM) on a single digital carrier.

The present document:

- gives a general description of the DVB-S2 system;
- specifies the digitally modulated signal in order to allow compatibility between pieces of equipment developed by different manufacturers. This is achieved by describing in detail the signal processing principles at the modulator side, while the processing at the receive side is left open to different implementation solutions. However, it is necessary in the present document to refer to certain aspects of reception;
- identifies the global performance requirements and features of the System, in order to meet the service quality targets.

2 References

References are either specific (identified by date of publication and/or edition number or version number) or non-specific.

- For a specific reference, subsequent revisions do not apply.
- Non-specific reference may be made only to a complete document or a part thereof and only in the following cases:
 - if it is accepted that it will be possible to use all future changes of the referenced document for the purposes of the referring document;
 - for informative references.

Referenced documents which are not found to be publicly available in the expected location might be found at <http://docbox.etsi.org/Reference>.

NOTE: While any hyperlinks included in this clause were valid at the time of publication ETSI cannot guarantee their long term validity.

2.1 Normative references

The following referenced documents are indispensable for the application of the present document. For dated references, only the edition cited applies. For non-specific references, the latest edition of the referenced document (including any amendments) applies.

- | | |
|-----|---|
| [1] | ISO/IEC 13818 (parts 1 and 2): "Information technology - Generic coding of moving pictures and associated audio information". |
| [2] | ETSI EN 300 421 (V.1.1.2): "Digital Video Broadcasting (DVB); Framing structure, channel coding and modulation for 11/12 GHz satellite services". |
| [3] | ETSI EN 301 210: "Digital Video Broadcasting (DVB); Framing structure, channel coding and modulation for Digital Satellite News Gathering (DSNG) and other contribution applications by satellite". |
| [4] | ETSI EN 301 192: "Digital Video Broadcasting (DVB); DVB specification for data broadcasting". |
| [5] | ETSI EN 300 429: "Digital Video Broadcasting (DVB); Framing structure, channel coding and modulation for cable systems". |
| [6] | ETSI EN 301 790: "Digital Video Broadcasting (DVB); Interaction channel for satellite distribution systems". |

- [7] ETSI ETS 300 801: "Digital Video Broadcasting (DVB); Interaction channel through Public Switched Telecommunications Network (PSTN)/ Integrated Services Digital Networks (ISDN)".
- [8] ETSI EN 301 195: "Digital Video Broadcasting (DVB); Interaction channel through the Global System for Mobile communications (GSM)".
- [9] ETSI ES 200 800: "Digital Video Broadcasting (DVB); DVB interaction channel for Cable TV distribution systems (CATV)".
- [10] ITU-R Recommendation SNG.770-1: "Uniform operational procedures for satellite news gathering (SNG)".
- [11] ETSI ETS 300 802: "Digital Video Broadcasting (DVB); Network-independent protocols for DVB interactive services".

2.2 Informative references

The following referenced documents are not essential to the use of the present document but they assist the user with regard to a particular subject area. For non-specific references, the latest version of the referenced document (including any amendments) applies.

- [i.1] ETSI TS 102 005: "Digital Video Broadcasting (DVB); Specification for the use of Video and Audio Coding in DVB services delivered directly over IP protocols".
- [i.2] ETSI EN 300 744: "Digital Video Broadcasting (DVB); Framing structure, channel coding and modulation for digital terrestrial television".
- [i.3] ETSI TR 101 154: "Digital Video Broadcasting (DVB); Implementation guidelines for the use of MPEG-2 Systems, Video and Audio in satellite, cable and terrestrial broadcasting applications".
- [i.4] ETSI TR 101 162: "Digital Video Broadcasting (DVB); Allocation of Service Information (SI) codes for DVB systems".

3 Symbols and abbreviations

3.1 Symbols

For the purposes of the present document, the following symbols apply:

α	Roll-off factor
γ	Ratio between constellation radii for 16APSK and 32APSK
c	codeword
C/N	Carrier-to-noise power ratio (N measured in a bandwidth equal to symbol rate)
$C/N+I$	Carrier-to-(Noise+Interference) ratio
$d_{n_{bch}-k_{bch}-1}, d_{n_{bch}-k_{bch}-2}, \dots, d_1, d_0$	BCH code redundancy bits
$d(x)$	BCH code remainder of the division between the generator polynomial and $x^{n_{bch}-k_{bch}} m(x)$
DFL	Data Field Length
d_{min}	LDPC code minimum distance
E_b/N_0	Ratio between the energy per information bit and single sided noise power spectral density
E_s/N_0	Ratio between the energy per transmitted symbol and single sided noise power spectral density
f_N	Nyquist frequency
f_0	Carrier frequency
G	PLS code generator matrix
$g(x)$	code generator polynomial

$g_1(x), g_2(x), \dots, g_{12}(x)$	polynomials to obtain BCH code generator polynomial
\mathbf{i}	LDPC code information block
$i_0, i_1, \dots, i_{k_{ldpc}-1}$	LDPC code information bits
$H(f)$	RC filters frequency transfer function
$H_{(n-k) \times n}$	LDPC code parity check matrix
I, Q	In-phase, Quadrature phase components of the modulated signal
K_{bch}	number of bits of BCH uncoded Block
N_{bch}	number of bits of BCH coded Block
k_{ldpc}	number of bits of LDPC uncoded Block
n_{ldpc}	number of bits of LDPC coded Block
η	PLFRAMING efficiency
η_c	code efficiency
η_{MOD}	number of transmitted bits per constellation symbol
η_{tot}	System spectral efficiency
m	BCH code information word
$m(x)$	BCH code message polynomial
$m_{k_{bch}-1}, m_{k_{bch}-2}, \dots, m_1, m_0$	BCH code information bits
M	number of modulated symbols in SLOT
$P_0, P_1, \dots, P_{n_{ldpc}-k_{ldpc}-1}$	LDPC code parity bits
P	number of pilot symbols in a pilot block
q	code rate dependant constant for LDPC codes
θ	deviation angle in hierarchical constellations
r_m	In-band ripple (dB)
R_s	Symbol rate corresponding to the bilateral Nyquist bandwidth of the modulated signal
R_u	Useful bit rate at the DVB-S2 system input
S	Number of Slots in a XFECFRAME
T_s	Symbol period

3.2 Abbreviations

For the purposes of the present document, the following abbreviations apply:

8PSK	8-ary Phase Shift Keying
16APSK	16-ary Amplitude and Phase Shift Keying
32APSK	32-ary Amplitude and Phase Shift Keying
ACM	Adaptive Coding and Modulation
ASI	Asynchronous Serial Interface
AWGN	Additive White Gaussian Noise
BB	BaseBand
BC	Backwards-Compatible

NOTE: Referred to the system allowing partial stream reception by DVB-S receivers.

BCH	Bose-Chaudhuri-Hocquenghem multiple error correction binary block code
BER	Bit Error Ratio
B_s	Bandwidth of the frequency Slot allocated to a service
BS	Broadcast Service
BSS	Broadcast Satellite Service
BW	BandWidth (at -3 dB) of the transponder
CBR	Constant Bit Rate
CCM	Constant Coding and Modulation
CNI	Carrier to Noise plus Interference ratio
CRC	Cyclic Redundancy Check
D	Decimal notation
DD	Decision Directed

DEMUX	DEMUltipleXer
DF	Data Field
DNP	Deleted Null Packets
DSNG	Digital Satellite News Gathering
DTH	Direct To Home
DTT	Digital Terrestrial Television
DVB	Digital Video Broadcasting project
DVB-S	DVB System for satellite broadcasting

NOTE: As specified in EN 300 421 [2].

DVB-S2 second generation DVB System for satellite broadcasting and unicasting

NOTE: As specified in the present document.

EBU	European Broadcasting Union
EN	European Norm
FDM	Frequency Division Multiplex
FEC	Forward Error Correction
FIFO	First In First Out
FSS	Fixed Satellite Service
GF	Galois Field
GS	Generic Stream
HDTV	High Definition TeleVision
HEX	HEXadecimal notation
HP	High Priority
IBO	Input Back Off
IF	Intermediate Frequency
IMUX	Input MUltipleXer - filter
IRD	Integrated Receiver Decoder
IS	Interactive Services
ISCR	Input Stream Clock Reference
ISI	Input Stream Identifier
ISSY	Input Stream SYNchronizer
ISSYI	Input Stream SYNchronizer Indicator
ITU	International Telecommunications Union
LDPC	Low Density Parity Check (codes)
LNB	Low Noise Block
LP	Low Priority
LSB	Least Significant Bit
MIS	Multiple Input Stream
MPE	Multi-Protocol Encapsulation
MPEG	Moving Pictures Experts Group
MSB	Most Significant Bit

NOTE: In DVB-S2 the MSB is always transmitted first.

NBC	Non-Backwards-Compatible
MUX	MUltipleX
NA	Not Applicable
NP	Null Packets
NPD	Null-Packet Deletion
OBO	Output Back Off
OCT	OCTal notation
OMUX	Output MUltipleXer - filter
PER	(MPEG TS) Packet Error Rate
PID	Packet IDentifier
PL	Physical Layer
PLL	Phase-Locked Loop
PLS	Physical Layer Signalling
PRBS	Pseudo Random Binary Sequence
PS	Professional Services
PSK	Phase Shift Keying

QEF	Quasi-Error-Free
QPSK	Quaternary Phase Shift Keying
RF	Radio Frequency
RO	Roll-Off
SDTV	Standard Definition TeleVision
SIS	Single Input Stream
SNG	Satellite News Gathering
SMATV	Satellite Master Antenna TeleVision
SOF	Start Of Frame
TDM	Time Division Multiplex
TS	Transport Stream
TV	TeleVision
TWTA	Travelling Wave Tube Amplifier
UPL	User Packet Length
VCM	Variable Coding and Modulation
TSDT	Transport Stream Descriptor Table

4 Transmission system description

4.1 System definition

The System is defined as the functional block of equipment performing the adaptation of the baseband digital signals, from the output of a single (or multiple) MPEG transport stream multiplexer(s) (ISO/IEC 13818-1 [1]), or from the output of a single (or multiple) generic data source(s), to the satellite channel characteristics. The System is designed to support source coding as defined in ISO/IEC 13818 [1], TR 101 154 [i.3] and TS 102 005 [i.1]. Data services may be transported in Transport Stream format according to EN 301 192 [4] (e.g. using Multi-protocol Encapsulation), or Generic Stream format.

If the received signal is above the C/N+I threshold, the Forward Error Correction (FEC) technique adopted in the System is designed to provide a "Quasi Error Free" (QEF) quality target. The definition of QEF adopted for DVB-S2 is "less than one uncorrected error-event per transmission hour at the level of a 5 Mbit/s single TV service decoder", approximately corresponding to a Transport Stream Packet Error Ratio $PER < 10^{-7}$ before de-multiplexer.

4.2 System architecture

According to figure 1, the DVB-S2 System shall be composed of a sequence of functional blocks as described below.

Mode adaptation shall be application dependent. It shall provide input stream interfacing, Input Stream Synchronization (optional), null-packet deletion (for ACM and Transport Stream input format only), CRC-8 coding for error detection at packet level in the receiver (for packetized input streams only), merging of input streams (for Multiple Input Stream modes only) and slicing into DATA FIELDS. For Constant Coding and Modulation (CCM) and single input Transport Stream, Mode Adaptation shall consist of a "transparent" DVB-ASI (or DVB-parallel) to logical-bit conversion and CRC-8 coding. For Adaptive Coding and Modulation (ACM), Mode Adaptation shall be according to annex D.

A Base-Band Header shall be appended in front of the Data Field, to notify the receiver of the input stream format and Mode Adaptation type. To be noted that the MPEG multiplex transport packets may be asynchronously mapped to the Base-Band Frames.

For applications requiring sophisticated merging policies, in accordance with specific service requirements (e.g. Quality of Service), Mode Adaptation may optionally be performed by a separate device, respecting all the rules of the DVB-S2 specification. To allow standard interfacing between Mode and Stream Adaptation functions, an optional modulator interface (Mode adaptation input interface) is defined, according to clauses I.1 (separate signalling circuit) or I.2 (in-band signalling).

Stream adaptation shall be applied, to provide padding to complete a Base-Band Frame and Base-Band Scrambling.

Forward Error Correction (FEC) Encoding shall be carried out by the concatenation of BCH outer codes and LDPC (Low Density Parity Check) inner codes (rates 1/4, 1/3, 2/5, 1/2, 3/5, 2/3, 3/4, 4/5, 5/6, 8/9, 9/10). Depending on the application area, the FEC coded block shall have length $n_{ldpc} = 64\,800$ bits or $16\,200$ bits. When VCM and ACM is used, FEC and modulation mode may be changed in different frames, but remains constant within a frame. For Backwards Compatible modes, the bit-stream at the output of the FEC encoder shall be processed according to annex F. Bit interleaving shall be applied to FEC coded bits for 8PSK, 16APSK and 32APSK.

Mapping into QPSK, 8PSK, 16APSK and 32APSK constellations shall be applied, depending on the application area. Gray mapping of constellations shall be used for QPSK and 8PSK.

Physical layer framing shall be applied, synchronous with the FEC frames, to provide Dummy PLFRAME insertion, Physical Layer (PL) Signalling, pilot symbols insertion (optional) and Physical Layer Scrambling for energy dispersal. Dummy PLFRAMEs are transmitted when no useful data is ready to be sent on the channel. The System provides a regular physical layer framing structure, based on SLOTS of $M = 90$ modulated symbols, allowing reliable receiver synchronization on the FEC block structure. A slot is devoted to physical layer signalling, including Start-of-Frame delimitation and transmission mode definition. This mechanism is suitable also for VCM and ACM demodulator setting. Carrier recovery in the receivers may be facilitated by the introduction of a regular raster of pilot symbols ($P = 36$ pilot symbols every 16 SLOTS of 90 symbols), while a pilot-less transmission mode is also available, offering an additional 2,4 % useful capacity.

Base-Band Filtering and Quadrature Modulation shall be applied, to shape the signal spectrum (squared-root raised cosine, roll-off factors 0,35 or 0,25 or 0,20) and to generate the RF signal.

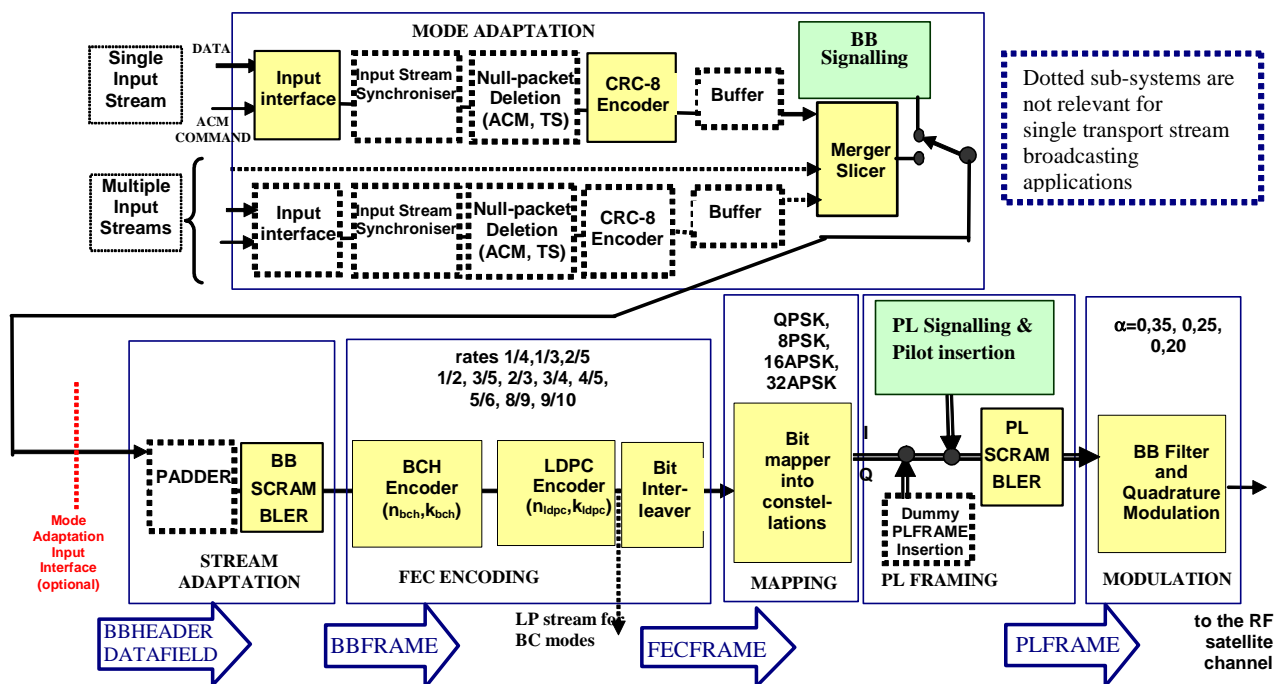

Figure 1: Functional block diagram of the DVB-S2 System

4.3 System configurations

Table 1 associates the System configurations to the applications areas. According to table 1, at least "Normative" subsystems and functionalities shall be implemented in the transmitting and receiving equipment to comply with the present document Guidelines for mode selection are given in annex H.

Table 1: System configurations and application areas

System configurations		Broadcast services	Interactive services	DSNG	Professional services
QPSK	1/4, 1/3, 2/5	O	N	N	N
	1/2, 3/5, 2/3, 3/4, 4/5, 5/6, 8/9, 9/10	N	N	N	N
8PSK	3/5, 2/3, 3/4, 5/6, 8/9, 9/10	N	N	N	N
16APSK	2/3, 3/4, 4/5, 5/6, 8/9, 9/10	O	N	N	N
32APSK	3/4, 4/5, 5/6, 8/9, 9/10	O	N	N	N
CCM		N	N (see note 1)	N	N
VCM		O	O	O	O
ACM		NA	N (see note 2)	O	O
FECFRAME (normal)	64 800 (bits)	N	N	N	N
FECFRAME (short)	16 200 (bits)	NA	N	O	N
Single Transport Stream		N	N (see note 1)	N	N
Multiple Transport Streams		O	O (see note 2)	O	O
Single Generic Stream		NA	O (see note 2)	NA	O
Multiple Generic Streams		NA	O (see note 2)	NA	O
Roll-off 0,35, 0,25 and 0,20		N	N	N	N
Input Stream Synchronizer		NA except (see note 3)	O (see note 3)	O (see note 3)	O (see note 3)
Null Packet Deletion		NA except (see note 3)	O (see note 3)	O (see note 3)	O (see note 3)
Dummy Frame insertion		NA except (see note 3)	N	N	N

N = normative, O = optional, NA = not applicable.

NOTE 1: Interactive service receivers shall implement CCM and Single Transport Stream.

NOTE 2: Interactive Service Receivers shall implement ACM at least in one of the two options: Multiple Transport Streams or Generic Stream (single/multiple input).

NOTE 3: Normative for single/multiple TS input stream(s) combined with ACM/VCM or for multiple TS input streams combined with CCM.

Within the present document, a number of configurations and mechanisms are defined as "Optional". Configurations and mechanisms explicitly indicated as "optional" within the present document, for a given application area, need not be implemented in the equipment to comply with the present document. Nevertheless, when an "optional" mode or mechanism is implemented, it shall comply with the specification as given in the present document.

5 Subsystems specification

The subsystem specification description is organized according to the functional block diagram of figure 1.

5.1 Mode adaptation

This sub-system shall perform Input Interfacing, Input Stream Synchronization (optional), Null-packet deletion (for TS input streams and ACM only), CRC-8 encoding for error detection (for packetized input streams only), input stream merging (for multiple input streams only) and input stream slicing in DATA FIELDS. Finally, base-band signalling shall be inserted, to notify the receiver of the adopted Mode Adaptation format.

According to figure 3, the input sequence(s) is (are):

- Single or multiple Transport Streams (TS).
- Single or multiple Generic Streams (packetized or continuous).

The output sequence is a BBHEADER (80 bits) followed by a DATA FIELD.

5.1.1 Input interface

The System, as defined in the present document, shall be delimited by the interfaces given in table 2.

Table 2: System interfaces

Location	Interface	Interface type	Connection	Multiplicity
Transmit station	Input	MPEG [1, 4] Transport Stream (see note 1)	from MPEG multiplexer	Single or multiple
Transmit station	Input (see note 2)	Generic Stream	From data sources	Single or multiple
Transmit station	Input (see note 3)	ACM command	From rate control unit	Single
Transmit station	Output	70/140 MHz IF, L-band IF, RF (see note 4)	to RF devices	Single or multiple
Transmit station	Input	Mode Adaptation	from Mode Adaptation block	Single
NOTE 1: For interoperability reasons, the Asynchronous Serial Interface (ASI) with 188 bytes format, data burst mode (bytes regularly spread over time) is recommended.				
NOTE 2: For data services.				
NOTE 3: For ACM only. Allows external setting of the ACM transmission mode.				
NOTE 4: IF shall be higher than twice the symbol rate.				

The input interface subsystem shall map the input electrical format into internal logical-bit format. The first received bit will be indicated as the Most Significant Bit (MSB).

A Transport Stream shall be characterized by User Packets (UP) of constant length $UPL = 188 \times 8$ bits (one MPEG packet), the first byte being a Sync-byte (47_{HEX}).

A Generic Stream shall be characterized by a continuous bit-stream or a stream of constant-length User Packets (UP), with length UPL bits (maximum UPL value 64 K, $UPL = 0_{\text{D}}$ means continuous stream, see clause 5.1.5). A variable length packet stream, or a constant length packet exceeding 64 kbit, shall be treated as a continuous stream.

For Generic packetized streams, if a synch-byte is the first byte of the UP, it shall be left unchanged, otherwise a synch-byte = 0_{D} shall be inserted before each packet, and UPL shall be increased by eight. UPL information may be derived by static modulator setting.

"ACM Command" signalling input shall allow setting, by an external "transmission mode control unit", of the transmission parameters to be adopted by the DVB-S2 modulator, for a specific portion of input data. ACM command shall be according to clause D.1.

Mode Adaptation (optional input) shall be a sequence of Data Fields (according to clause 5.1.5), where each individual Data Field is preceded by a BBHEADER, according to clause 5.1.6 and to figure 3, and Stream Adaptation Command, according to clause I.1, to allow setting, by an external 3mode adaptation unit", of the transmission parameters to be adopted by the DVB-S2 modulator, for each specific MA Packet. Mode Adaptation shall be according to clause I.1 (separate signalling circuit) or I.2 (in-band signalling).

5.1.2 Input stream synchronizer (optional, not relevant for single TS - BS)

Data processing in the DVB-S2 modulator may produce variable transmission delay on the user information. The Input Stream Synchronizer subsystem (optional) shall provide suitable means to guarantee Constant-Bit-Rate (CBR) and constant end-to-end transmission delay for packetized input streams (e.g. for Transport Streams). This process shall follow the specification given in annex D. Examples of receiver implementation are given in annex G.

5.1.3 Null-Packet Deletion (ACM and Transport Stream only)

For ACM modes and Transport Stream input data format, MPEG null-packets shall be identified ($PID = 8191_{\text{D}}$) and removed. This allows to reduce the information rate and increase the error protection in the modulator. The process is carried-out in a way that the removed null-packets can be re-inserted in the receiver in the exact place where they originally were. This process shall follow the specification given in annex D.

5.1.4 CRC-8 encoder (for packetized streams only)

If $UPL = 0_D$ (continuous generic stream) this sub-system shall pass forward the input stream without modifications.

If $UPL \neq 0_D$ the input stream is a sequence of User Packets of length UPL bits, preceded by a sync-byte (the sync-byte being $= 0_D$ when the original stream did not contain a sync-byte).

The useful part of the UP (excluding the sync-byte) shall be processed by a systematic 8-bit CRC encoder. The generator polynomial shall be:

$$g(X) = (X^5 + X^4 + X^3 + X^2 + 1)(X^2 + X + 1)(X + 1) = X^8 + X^7 + X^6 + X^4 + X^2 + 1$$

The CRC encoder output shall be computed as:

$$\text{CRC} = \text{remainder} [X^8 u(X) : g(X)]$$

Where $u(X)$ is the input sequence (UPL - 8 bits) to be systematically encoded. Figure 2 gives a possible implementation of the CRC generator by means of a shift register.

The register shall be initialized to all zeros before the first bit of each sequence enters the circuit.

The computed CRC-8 shall replace the sync-byte of the following UP. As described in clause 5.1.6, the sync-byte is copied into the SYNC field of the BBHEADER for transmission.

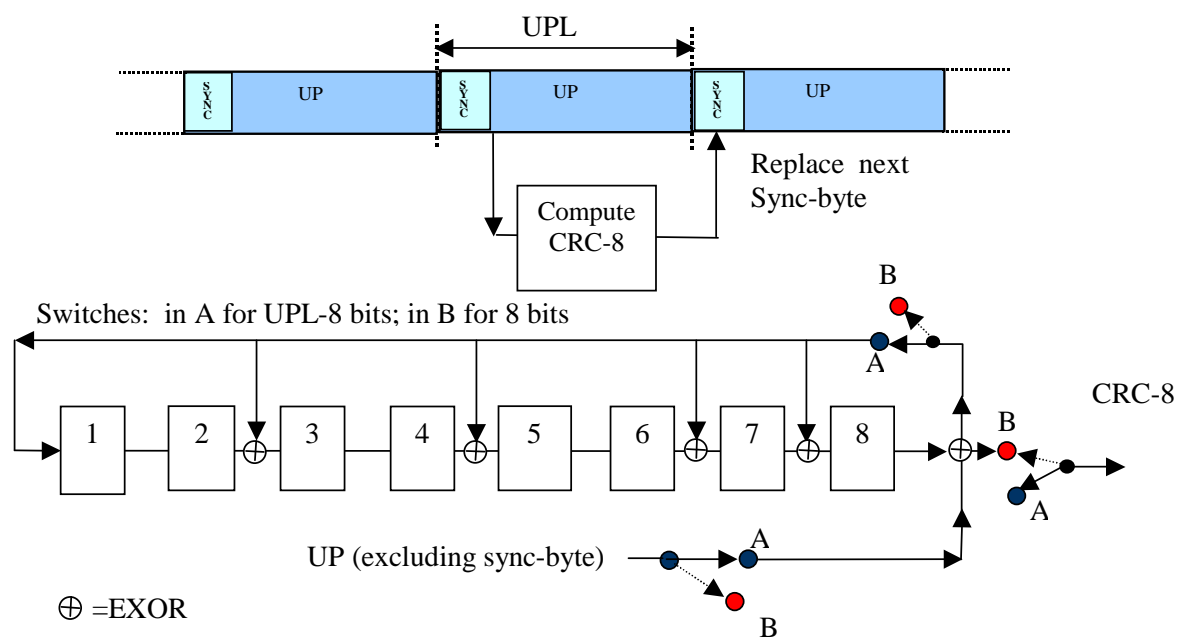

Figure 2: Implementation of the CRC-8 encoder

5.1.5 Merger/Slicer

According to figure 3, the Merger/Slicer input stream(s) is (are) organized as Generic continuous Stream(s) or Packetized Input Stream(s). The UP length is UPL bits (where $UPL = 0$ means continuous sequence). The input stream(s) shall be buffered until the Merger/Slicer may read them.

The Slicer shall read (i.e. slice) from its input (single input stream), or from one of its inputs (multiple input streams) a DATA FIELD, composed of DFL bits (Data Field Length), where:

$$K_{\text{bch}} - (10 \times 8) \geq \text{DFL} \geq 0 \quad (K_{\text{bch}} \text{ as per table 5, 80 bits are dedicated to the BBHEADER, see clause 5.1.6).}$$

The Merger shall concatenate, in a single output, different data fields read and sliced from one of its inputs. In presence of a single stream, only the slicing functionality applies.

A DATA FIELD shall be composed of bits taken from a single input port and shall be transmitted in a homogeneous transmission mode (FEC code and modulation). The Merger/Slicer prioritization policies are application dependent and shall follow the strategies described in table 4 (Single Transport Stream Broadcast services) and in table D.2 (for other application areas).

Depending on the applications, the Merger/Slicer shall either allocate a number of input bits equal to the maximum DATAFIELD capacity ($DFL = K_{bch} - 80$), thus breaking UPs in subsequent DATAFIELDS, or shall allocate an integer number of UPs within the DATAFIELD, making the DFL variable within the above specified boundaries.

When a DATA FIELD is not available at the merger/slicer request on any input port, the Physical Layer Framing sub-system shall generate and transmit a DUMMY PLFRAME (see clause 5.5.1 and table 12).

After Sync-byte replacing by CRC-8 (see clause 5.1.4), it is necessary to provide the receiver a method to recover UP synchronization (when the receiver is already synchronized to the DATA FIELD). Therefore the number of bits from the beginning of the DATA FIELD and the beginning of the first complete UP (first bit of the CRC-8) (see figure 3) shall be detected by the Merger/Slicer and stored in SYNC D field (i.e. SYNC Distance) of the Base-Band Header (see clause 5.1.6). For example, $SYNCD = 0_D$ means that the first USER PACKET is aligned to the DATA FIELD.

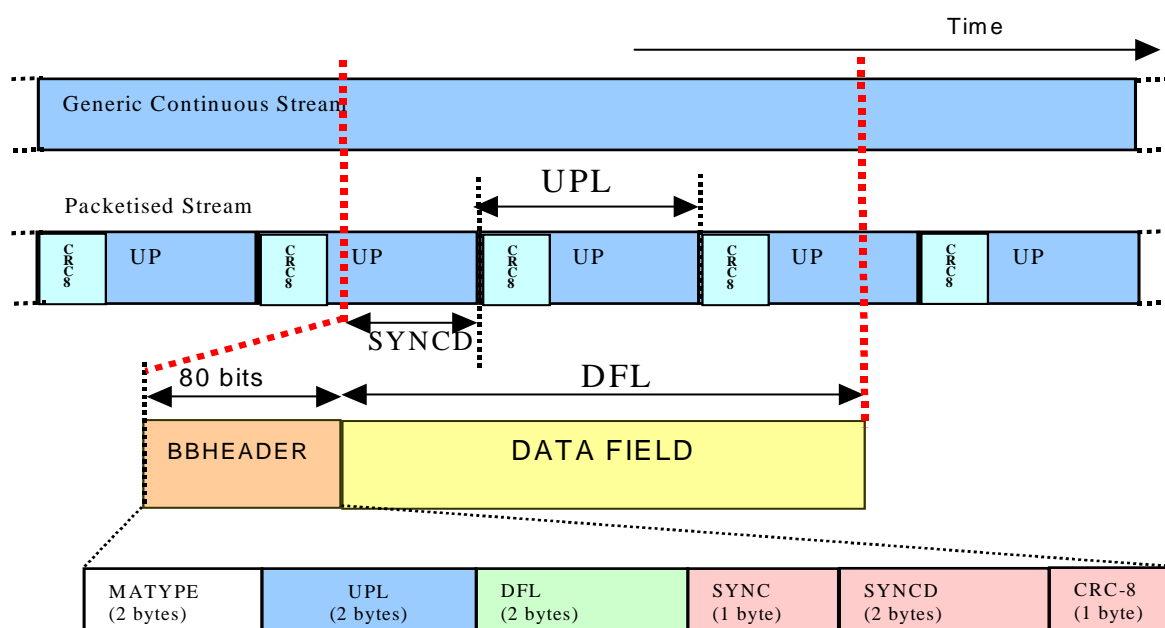

Figure 3: Stream format at the output of the MODE ADAPTER

5.1.6 Base-Band Header insertion

A fixed length base-band Header (BBHEADER) of 10 bytes shall be inserted in front of the DATA FIELD, describing its format (the maximum efficiency loss introduced by the BBHEADER is 0,25 % for $n_{ldpc} = 64\ 800$ and 1 % for $n_{ldpc} = 16\ 200$ assuming inner code rate 1/2).

MATYPE (2 bytes): describes the input stream(s) format, the type of Mode Adaptation and the transmission Roll-off factor, as explained in table 3.

First byte (MATYPE-1):

- TS/GS field (2 bits): Transport Stream Input or Generic Stream Input (packetized or continuous).
- SIS/MIS field (1 bit): Single Input Stream or Multiple Input Stream.
- CCM/ACM field (1 bit): Constant Coding and Modulation or Adaptive Coding and Modulation (VCM is signalled as ACM).
- ISSYI (1 bit), (Input Stream Synchronization Indicator): If $ISSYI = 1$ = active, the ISSY field is inserted after UPs (see annex D).

- NPD (1 bit): Null-packet deletion active/not active.
- RO (2 bits): Transmission Roll-off factor (α).

Second byte (MATYPE-2):

- If SIS/MIS = Multiple Input Stream, then second byte = Input Stream Identifier (ISI); else second byte reserved.

UPL (2 bytes): User Packet Length in bits, in the range 0 to 65 535.

EXAMPLE 1: 0000_{HEX} = continuous stream.

EXAMPLE 2: 000A_{HEX} = UP length of 10 bits.

EXAMPLE 3: UPL = 188x8_D for MPEG transport stream packets.

DFL (2 bytes): Data Field Length in bits, in the range 0 to 58 112.

EXAMPLE 4: 000A_{HEX} = Data Field length of 10 bits.

SYNC (1 byte): copy of the User Packet Sync-byte:

- for packetized Transport or Generic Streams: copy of the User Packet Sync byte;
- for Continuous Generic Streams: SYNC= 00 - B8 reserved for transport layer protocol signaling according to Reference [i.4]; SYNC= B9-FF user private).

EXAMPLE 5: SYNC = 47_{HEX} for MPEG transport stream packets.

EXAMPLE 6: SYNC = 00_{HEX} when the input Generic packetized stream did not contain a sync-byte (therefore the receiver, after CRC-8 decoding, shall remove the CRC-8 field without reinserting the Sync-byte).

SYNCD (2 bytes):

- for packetized Transport or Generic Streams: distance in bits from the beginning of the DATA FIELD and the first UP from this frame (first bit of the CRC-8). SYNCD = 65535_D means that no UP starts in the DATA FIELD;
- for Continuous Generic Streams: SYNCD= 0000 - FFFF reserved for future uses.

CRC-8 (1 byte): error detection code applied to the first 9 bytes of the BBHEADER.

CRC-8 shall be computed using the encoding circuit of figure 2 (switch in A for 72 bits, in B for 8 bits).

The BBHEADER transmission order is from the MSB of the TS/GS field.

Table 4 shows the BBHEADER and the slicing policy for a Single Transport Stream Broadcast Service. For other application areas, BBHEADERS and merging/slicing policies are defined in table D.2.

Table 3: MATYPE-1 field mapping

TS/GS	SIS/MIS	CCM/ACM	ISSYI	NPD	RO
11 = Transport	1 = single	1 = CCM	1 = active	1 = active	00 = 0,35
00 = Generic Packetized	0 = multiple	0 = ACM	0 = not-active	0 = not-active	01 = 0,25
01 = Generic continuous					10 = 0,20
10 = reserved					11 = reserved

Table 4: BBHeader (Mode Adaptation characteristics) and Slicing Policy for Single Transport Stream Broadcast services

Application area/configuration	MATYPE-1	MATYPE-2	UPL	DFL	SYNC	SYNCD	CRC-8	Slicing policy
Broadcasting services / CCM, single TS	11-1-1-0-0-Y	XXXXXXXX	$188_D \times 8$	$K_{bch} - 80_D$	47 _{HEX}	Y	Y	Break No timeout No Padding No Dummy frame
X= not defined; Y = according to configuration/computation. Break = break packets in subsequent DATAFIELDS; Timeout: maximum delay in merger/slicer buffer.								

5.2 Stream adaptation

Stream adaptation (see figures 1 and 4) provides padding to complete a constant length (K_{bch} bits) BBFRAME and scrambling. K_{bch} depends on the FEC rate, as reported in table 5. Padding may be applied in circumstances when the user data available for transmission are not sufficient to completely fill a BBFRAME, or when an integer number of UPs has to be allocated in a BBFRAME.

The input stream shall be a BBHEADER followed by a DATA FIELD. The output stream shall be a BBFRAME.

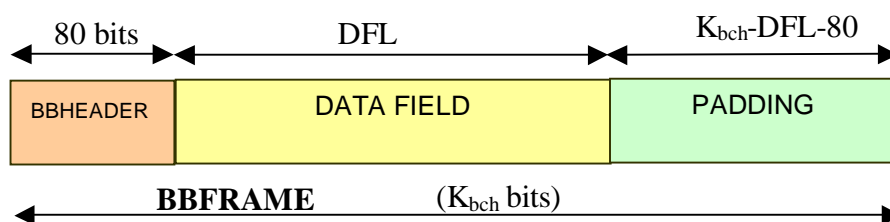

Figure 4: BBFRAME format at the output of the STREAM ADAPTER

5.2.1 Padding

$(K_{bch} - DFL - 80)$ zero bits shall be appended after the DATA FIELD. The resulting BBFRAME shall have a constant length of K_{bch} bits. For Broadcast Service applications, $DFL = K_{bch} - 80$, therefore no padding shall be applied.

5.2.2 BB scrambling

The complete BBFRAME shall be randomized. The randomization sequence shall be synchronous with the BBFRAME, starting from the MSB and ending after K_{bch} bits.

The scrambling sequence shall be generated by the feed-back shift register of figure 5. The polynomial for the Pseudo Random Binary Sequence (PRBS) generator shall be:

$$1 + X^{14} + X^{15}$$

Loading of the sequence (10010101000000) into the PRBS register, as indicated in figure 5, shall be initiated at the start of every BBFRAME.

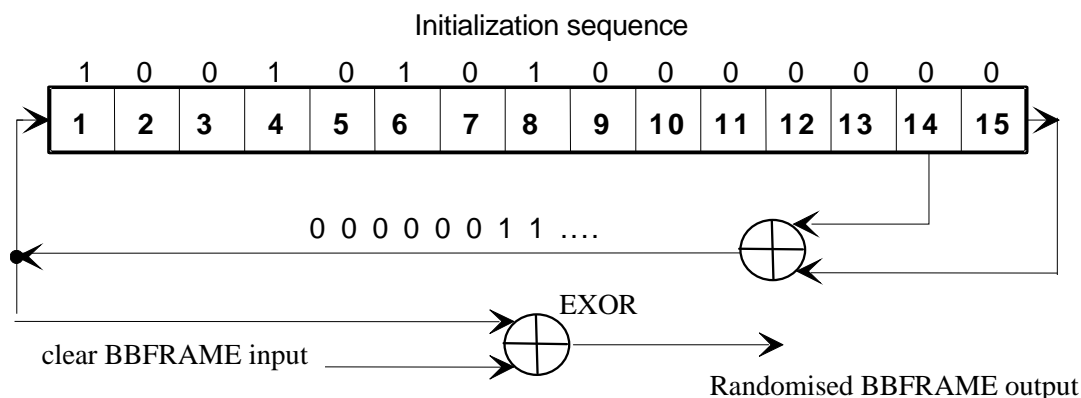

Figure 5: Possible implementation of the PRBS encoder

5.3 FEC encoding

This sub-system shall perform outer coding (BCH), Inner Coding (LDPC) and Bit interleaving. The input stream shall be composed of BBFRAMEs and the output stream of FECFRAMEs.

Each BBFRAME (K_{bch} bits) shall be processed by the FEC coding subsystem, to generate a FECFRAME (n_{ldpc} bits). The parity check bits (BCHFEC) of the systematic BCH outer code shall be appended after the BBFRAME, and the parity check bits (LDPCFEC) of the inner LDPC encoder shall be appended after the BCHFEC field, as shown in figure 6.

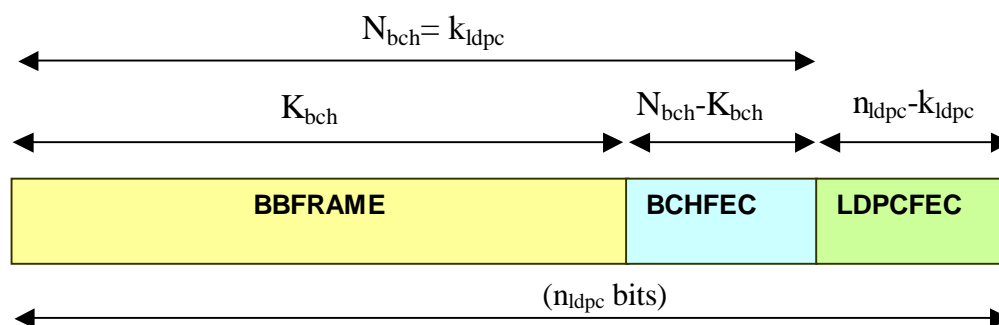

Figure 6: Format of data before bit interleaving
($n_{\text{ldpc}} = 64\,800$ bits for normal FECFRAME, $n_{\text{ldpc}} = 16\,200$ bits for short FECFRAME)

Table 5a gives the FEC coding parameters for the normal FECFRAME ($n_{\text{ldpc}} = 64\,800$ bits) and table 5b for the short FECFRAME ($n_{\text{ldpc}} = 16\,200$ bits).

Table 5a: Coding parameters (for normal FECFRAME $n_{\text{ldpc}} = 64\,800$)

LDPC code	BCH Uncoded Block K_{bch}	BCH coded block N_{bch} LDPC Uncoded Block k_{ldpc}	BCH t-error correction	LDPC Coded Block n_{ldpc}
1/4	16 008	16 200	12	64 800
1/3	21 408	21 600	12	64 800
2/5	25 728	25 920	12	64 800
1/2	32 208	32 400	12	64 800
3/5	38 688	38 880	12	64 800
2/3	43 040	43 200	10	64 800
3/4	48 408	48 600	12	64 800
4/5	51 648	51 840	12	64 800
5/6	53 840	54 000	10	64 800
8/9	57 472	57 600	8	64 800
9/10	58 192	58 320	8	64 800

Table 5b: Coding parameters (for short FECFRAME $n_{ldpc} = 16\ 200$)

LDPC Code identifier	BCH Uncoded Block K_{bch}	BCH coded block N_{bch} LDPC Uncoded Block k_{ldpc}	BCH t-error correction	Effective LDPC Rate $k_{ldpc}/16\ 200$	LDPC Coded Block n_{ldpc}
1/4	3 072	3 240	12	1/5	16 200
1/3	5 232	5 400	12	1/3	16 200
2/5	6 312	6 480	12	2/5	16 200
1/2	7 032	7 200	12	4/9	16 200
3/5	9 552	9 720	12	3/5	16 200
2/3	10 632	10 800	12	2/3	16 200
3/4	11 712	11 880	12	11/15	16 200
4/5	12 432	12 600	12	7/9	16 200
5/6	13 152	13 320	12	37/45	16 200
8/9	14 232	14 400	12	8/9	16 200
9/10	NA	NA	NA	NA	NA

5.3.1 Outer encoding (BCH)

A t-error correcting BCH (N_{bch} , K_{bch}) code shall be applied to each BBFRAME (K_{bch}) to generate an error protected packet. The BCH code parameters for $n_{ldpc} = 64\ 800$ are given in table 5a and for $n_{ldpc} = 16\ 200$ in table 5b.

The generator polynomial of the t error correcting BCH encoder is obtained by multiplying the first t polynomials in table 6a for $n_{ldpc} = 64\ 800$ and in table 5b for $n_{ldpc} = 16\ 200$.

Table 6a: BCH polynomials (for normal FECFRAME $n_{ldpc} = 64\ 800$)

$g_1(x)$	$1+x^2+x^3+x^5+x^{16}$
$g_2(x)$	$1+x+x^4+x^5+x^6+x^8+x^{16}$
$g_3(x)$	$1+x^2+x^3+x^4+x^5+x^7+x^8+x^9+x^{10}+x^{11}+x^{16}$
$g_4(x)$	$1+x^2+x^4+x^6+x^9+x^{11}+x^{12}+x^{14}+x^{16}$
$g_5(x)$	$1+x+x^2+x^3+x^5+x^8+x^9+x^{10}+x^{11}+x^{12}+x^{16}$
$g_6(x)$	$1+x^2+x^4+x^5+x^7+x^8+x^9+x^{10}+x^{12}+x^{13}+x^{14}+x^{15}+x^{16}$
$g_7(x)$	$1+x^2+x^5+x^6+x^8+x^9+x^{10}+x^{11}+x^{13}+x^{15}+x^{16}$
$g_8(x)$	$1+x+x^2+x^5+x^6+x^8+x^9+x^{12}+x^{13}+x^{14}+x^{16}$
$g_9(x)$	$1+x^5+x^7+x^9+x^{10}+x^{11}+x^{16}$
$g_{10}(x)$	$1+x+x^2+x^5+x^7+x^8+x^{10}+x^{12}+x^{13}+x^{14}+x^{16}$
$g_{11}(x)$	$1+x^2+x^3+x^5+x^9+x^{11}+x^{12}+x^{13}+x^{16}$
$g_{12}(x)$	$1+x+x^5+x^6+x^7+x^9+x^{11}+x^{12}+x^{16}$

Table 6b: BCH polynomials (for short FECFRAME $n_{ldpc} = 16\ 200$)

$g_1(x)$	$1+x+x^3+x^5+x^{14}$
$g_2(x)$	$1+x^6+x^8+x^{11}+x^{14}$
$g_3(x)$	$1+x+x^2+x^6+x^9+x^{10}+x^{14}$
$g_4(x)$	$1+x^4+x^7+x^8+x^{10}+x^{12}+x^{14}$
$g_5(x)$	$1+x^2+x^4+x^6+x^8+x^9+x^{11}+x^{13}+x^{14}$
$g_6(x)$	$1+x^3+x^7+x^8+x^9+x^{13}+x^{14}$
$g_7(x)$	$1+x^2+x^5+x^6+x^7+x^{10}+x^{11}+x^{13}+x^{14}$
$g_8(x)$	$1+x^5+x^8+x^9+x^{10}+x^{11}+x^{14}$
$g_9(x)$	$1+x+x^2+x^3+x^9+x^{10}+x^{14}$
$g_{10}(x)$	$1+x^3+x^6+x^9+x^{11}+x^{12}+x^{14}$
$g_{11}(x)$	$1+x^4+x^{11}+x^{12}+x^{14}$
$g_{12}(x)$	$1+x+x^2+x^3+x^5+x^6+x^7+x^8+x^{10}+x^{13}+x^{14}$

BCH encoding of information bits $\mathbf{m} = (m_{k_{bch}-1}, m_{k_{bch}-2}, \dots, m_1, m_0)$ onto a codeword:

$\mathbf{c} = (m_{k_{bch}-1}, m_{k_{bch}-2}, \dots, m_1, m_0, d_{n_{bch}-k_{bch}-1}, d_{n_{bch}-k_{bch}-2}, \dots, d_1, d_0)$ is achieved as follows:

- Multiply the message polynomial $m(x) = m_{k_{bch}-1}x^{k_{bch}-1} + m_{k_{bch}-2}x^{k_{bch}-2} + \dots + m_1x + m_0$ by $x^{n_{bch}-k_{bch}}$.
- Divide $x^{n_{bch}-k_{bch}}m(x)$ by $g(x)$, the generator polynomial. Let $d(x) = d_{n_{bch}-k_{bch}-1}x^{n_{bch}-k_{bch}-1} + \dots + d_1x + d_0$ be the remainder.
- Set the codeword polynomial $c(x) = x^{n_{bch}-k_{bch}}m(x) + d(x)$.

5.3.2 Inner encoding (LDPC)

LDPC encoder systematically encodes an information block of size k_{ldpc} , $\mathbf{i} = (i_0, i_1, \dots, i_{k_{ldpc}-1})$ onto a codeword of size n_{ldpc} , $\mathbf{c} = (i_0, i_1, \dots, i_{k_{ldpc}-1}, p_0, p_1, \dots, p_{n_{ldpc}-k_{ldpc}-1})$. The transmission of the codeword starts in the given order from i_0 and ends with $p_{n_{ldpc}-k_{ldpc}-1}$.

LDPC code parameters (n_{ldpc}, k_{ldpc}) are given in tables 5a and 5b.

For Backwards Compatible modes, the output of the inner encoder is processed according to annex F.

5.3.2.1 Inner coding for normal FECFRAME

The task of the encoder is to determine $n_{ldpc} - k_{ldpc}$ parity bits $(p_0, p_1, \dots, p_{n_{ldpc}-k_{ldpc}-1})$ for every block of k_{ldpc} information bits, $(i_0, i_1, \dots, i_{k_{ldpc}-1})$. The procedure is as follows:

- Initialize $p_0 = p_1 = p_2 = \dots = p_{n_{ldpc}-k_{ldpc}-1} = 0$.
- Accumulate the first information bit, i_0 , at parity bit addresses specified in the first row of tables B.1 through B.11 in annex B. For example, for rate 2/3 (table B.6), (all additions are in GF(2)):

$$\begin{array}{ll}
 p_0 = p_0 \oplus i_0 & p_{2767} = p_{2767} \oplus i_0 \\
 p_{10491} = p_{10491} \oplus i_0 & p_{240} = p_{240} \oplus i_0 \\
 p_{16043} = p_{16043} \oplus i_0 & p_{18673} = p_{18673} \oplus i_0 \\
 p_{506} = p_{506} \oplus i_0 & p_{9279} = p_{9279} \oplus i_0 \\
 p_{12826} = p_{12826} \oplus i_0 & p_{10579} = p_{10579} \oplus i_0 \\
 p_{8065} = p_{8065} \oplus i_0 & p_{20928} = p_{20928} \oplus i_0 \\
 p_{8226} = p_{8226} \oplus i_0 &
 \end{array}$$

- For the next 359 information bits, i_m , $m = 1, 2, \dots, 359$ accumulate i_m at parity bit addresses $\{x + m \bmod 360 \times q\} \bmod (n_{ldpc} - k_{ldpc})$ where x denotes the address of the parity bit accumulator corresponding to the first bit i_0 , and q is a code rate dependent constant specified in table 7a. Continuing with the example, $q = 60$ for rate 2/3. So for example for information bit i_1 , the following operations are performed,

$$\begin{array}{ll}
 p_{60} = p_{60} \oplus i_1 & p_{2827} = p_{2827} \oplus i_1 \\
 p_{10551} = p_{10551} \oplus i_1 & p_{300} = p_{300} \oplus i_1
 \end{array}$$

$$p_{16103} = p_{16103} \oplus i_1$$

$$p_{18733} = p_{18733} \oplus i_1$$

$$p_{566} = p_{566} \oplus i_1$$

$$p_{9339} = p_{9339} \oplus i_1$$

$$p_{12886} = p_{12886} \oplus i_1$$

$$p_{10639} = p_{10639} \oplus i_1$$

$$p_{8125} = p_{8125} \oplus i_1$$

$$p_{20988} = p_{20988} \oplus i_1$$

$$p_{8286} = p_{8286} \oplus i_1$$

- For the 361st information bit i_{360} , the addresses of the parity bit accumulators are given in the second row of the tables B.1 through B.11. In a similar manner the addresses of the parity bit accumulators for the following 359 information bits $i_m, m = 361, 362, \dots, 719$ are obtained using the formula $\{x + (m \bmod 360) \times q\} \bmod (n_{ldpc} - k_{ldpc})$ where x denotes the address of the parity bit accumulator corresponding to the information bit i_{360} , i.e. the entries in the second row of the tables B.1 through B.11.
- In a similar manner, for every group of 360 new information bits, a new row from tables B.1 through B.11 are used to find the addresses of the parity bit accumulators.

After all of the information bits are exhausted, the final parity bits are obtained as follows:

- Sequentially perform the following operations starting with $i = 1$.

$$p_i = p_i \oplus p_{i-1}, \quad i = 1, 2, \dots, n_{ldpc} - k_{ldpc} - 1$$

- Final content of $p_i, i = 0, 1, \dots, n_{ldpc} - k_{ldpc} - 1$ is equal to the parity bit p_i .

Table 7a: q values for normal frames

Code Rate	q
1/4	135
1/3	120
2/5	108
1/2	90
3/5	72
2/3	60
3/4	45
4/5	36
5/6	30
8/9	20
9/10	18

5.3.2.2 Inner coding for short FECFRAME

k_{ldpc} BCH encoded bits shall be systematically encoded to generate n_{ldpc} bits as described in clause 5.3.2.1, replacing table 7a with table 7b, the tables of annex B with the tables of annex C.

Table 7b: q values for short frames

Code Rate	q
1/4	36
1/3	30
2/5	27
1/2	25
3/5	18
2/3	15
3/4	12
4/5	10
5/6	8
8/9	5

5.3.3 Bit Interleaver (for 8PSK, 16APSK and 32APSK only)

For 8PSK, 16APSK, and 32APSK modulation formats, the output of the LDPC encoder shall be bit interleaved using a block interleaver. Data is serially written into the interleaver column-wise, and serially read out row-wise (the MSB of BBHEADER is read out first, except 8PSK rate 3/5 case where MSB of BBHEADER is read out third) as shown in figures 7 and 8.

The configuration of the block interleaver for each modulation format is specified in table 8.

Table 8: Bit Interleaver structure

Modulation	Rows (for $n_{ldpc} = 64\ 800$)	Rows (for $n_{ldpc} = 16\ 200$)	Columns
8PSK	21 600	5 400	3
16APSK	16 200	4 050	4
32APSK	12 960	3 240	5

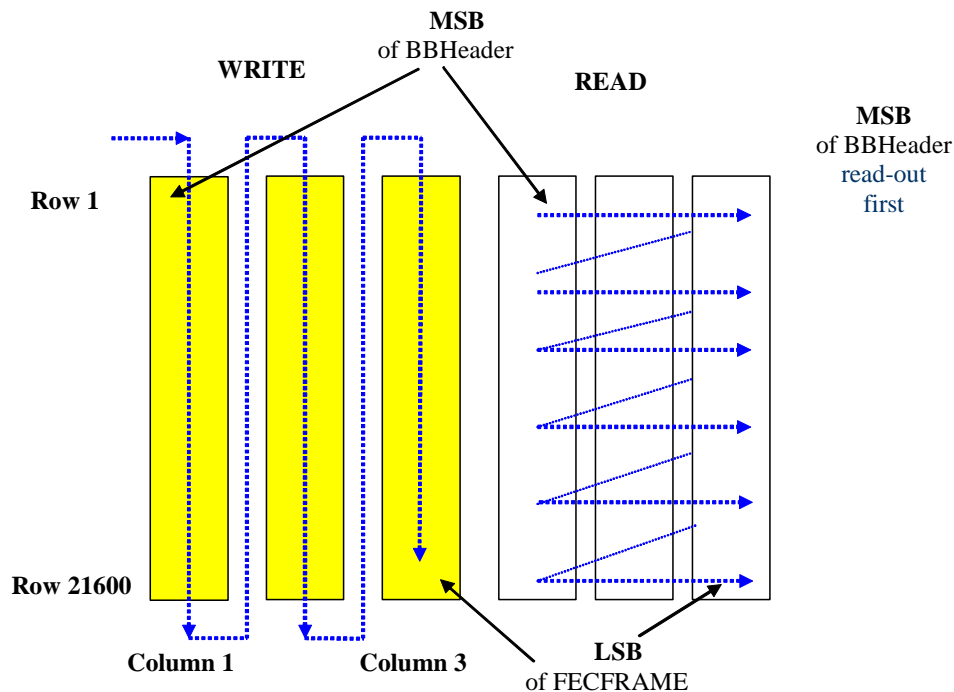

Figure 7: Bit Interleaving scheme for 8PSK and normal FECFRAME length (all rates except 3/5)

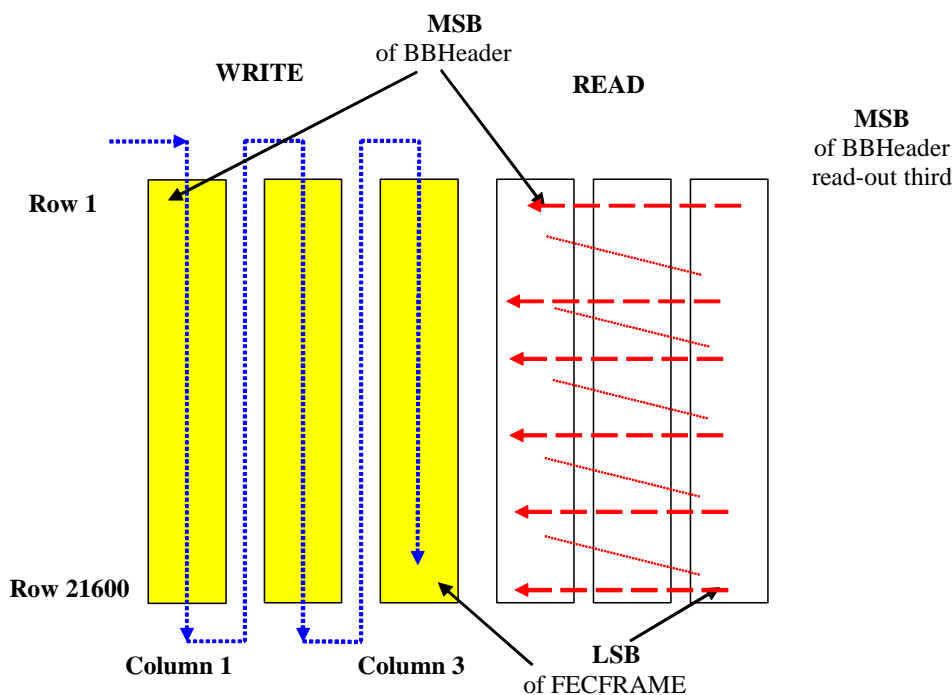

Figure 8: Bit Interleaving scheme for 8PSK and normal FECFRAME length (rate 3/5 only)

5.4 Bit mapping into constellation

Each FECFRAME (which is a sequence of 64 800 bits for normal FECFRAME, or 16 200 bits for short FECFRAME), shall be serial-to-parallel converted (parallelism level = $\eta_{\text{MOD}}/2$ for QPSK, 3 for 8PSK, 4 for 16APSK, 5 for 32APSK) in figures 9 to 12, the MSB of the FECFRAME is mapped into the MSB of the first parallel sequence. Each parallel sequence shall be mapped into constellation, generating a (I,Q) sequence of variable length depending on the selected modulation efficiency η_{MOD} .

The input sequence shall be a FECFRAME, the output sequence shall be a XFECFRAME (complex FECFRAME), composed of $64\,800/\eta_{\text{MOD}}$ (normal XFECFRAME) or $16\,200/\eta_{\text{MOD}}$ (short XFECFRAME) modulation symbols. Each modulation symbol shall be a complex vector in the format (I,Q) (I being the in-phase component and Q the quadrature component) or in the equivalent format $\rho \exp(j\phi)$ (ρ being the modulus of the vector and ϕ being its phase).

5.4.1 Bit mapping into QPSK constellation

For QPSK, the System shall employ conventional Gray-coded QPSK modulation with absolute mapping (no differential coding). Bit mapping into the QPSK constellation shall follow figure 9. The normalized average energy per symbol shall be equal to $\rho^2 = 1$.

Two FECFRAME bits are mapped to a QPSK symbol i.e. bits $2i$ and $2i+1$ determines the i^{th} QPSK symbol, where $i = 0, 1, 2, \dots, (N/2)-1$ and N is the coded LDPC block size.

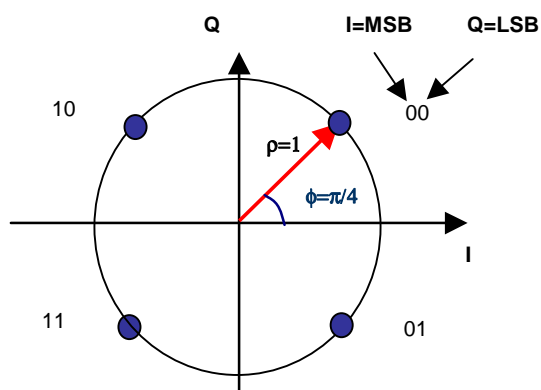

Figure 9: Bit mapping into QPSK constellation

5.4.2 Bit mapping into 8PSK constellation

For 8PSK, the System shall employ conventional Gray-coded 8PSK modulation with absolute mapping (no differential coding). Bit mapping into the 8PSK constellation shall follow figure 10. The normalized average energy per symbol shall be equal to $\rho^2 = 1$.

Bits $3i$, $3i+1$, $3i+2$ of the interleaver output determine the i^{th} 8PSK symbol where $i = 0, 1, 2, \dots (N/3)-1$ and N is the coded LDPC block size.

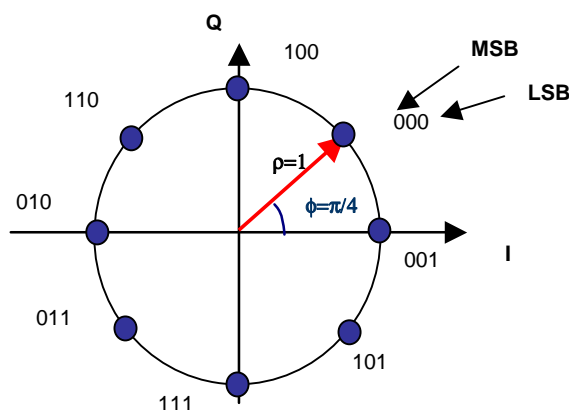

Figure 10: Bit mapping into 8PSK constellation

5.4.3 Bit mapping into 16APSK constellation

The 16APSK modulation constellation (figure 11) shall be composed of two concentric rings of uniformly spaced 4 and 12 PSK points, respectively in the inner ring of radius R_1 and outer ring of radius R_2 .

The ratio of the outer circle radius to the inner circle radius ($\gamma = R_2/R_1$) shall comply with table 9.

Two are the admitted values for the constellation amplitudes, allowing performance optimization according to the channel characteristics (e.g. single or multiple carriers per transponder, use of non-linear predistortion):

- $E=1$ (E =unit average symbol energy) corresponding to $[R_1]^2 + 3[R_2]^2 = 4$
- $R_2=1$.

Bits $4i$, $4i+1$, $4i+2$ and $4i+3$ of the interleaver output determine the i^{th} 16APSK symbol, where $i = 0, 1, 2, \dots, (N/4)-1$ and N is the coded LDPC block size.

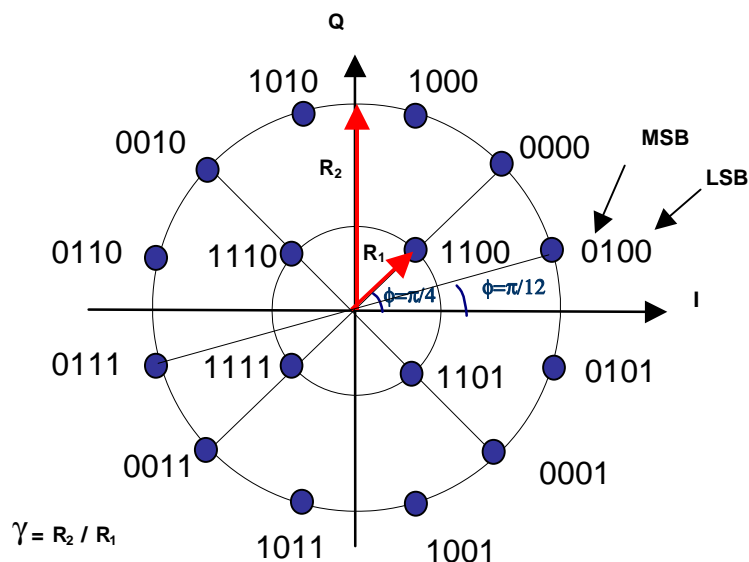

Figure 11: 16APSK signal constellation

Table 9: Optimum constellation radius ratio γ (linear channel) for 16APSK

Code rate	Modulation/coding spectral efficiency	γ
2/3	2,66	3,15
3/4	2,99	2,85
4/5	3,19	2,75
5/6	3,32	2,70
8/9	3,55	2,60
9/10	3,59	2,57

5.4.4 Bit mapping into 32APSK

The 32APSK modulation constellation (see figure 12) shall be composed of three concentric rings of uniformly spaced 4, 12 and 16 PSK points, respectively in the inner ring of radius R_1 , the intermediate ring of radius R_2 and the outer ring or radius R_3 . Table 10 defines the values of $Y_1 = R_2 / R_1$ and $Y_2 = R_3 / R_1$.

Two are the admitted values for the constellation amplitudes, allowing performance optimization according to the channel characteristics (e.g., single or multiple carriers per transponder, use of non-linear predistortion):

- $E=1$ (E =unit average symbol energy) corresponding to $[R_1]^2 + 3[R_2]^2 + 4[R_3]^2 = 8$.
- $R_3=1$.

Bits $5i, 5i+1, 5i+2, 5i+3$ and $5i+4$ of the interleaver output determine the i^{th} 32APSK symbol, where $i = 0, 1, 2, (N/5)-1$.

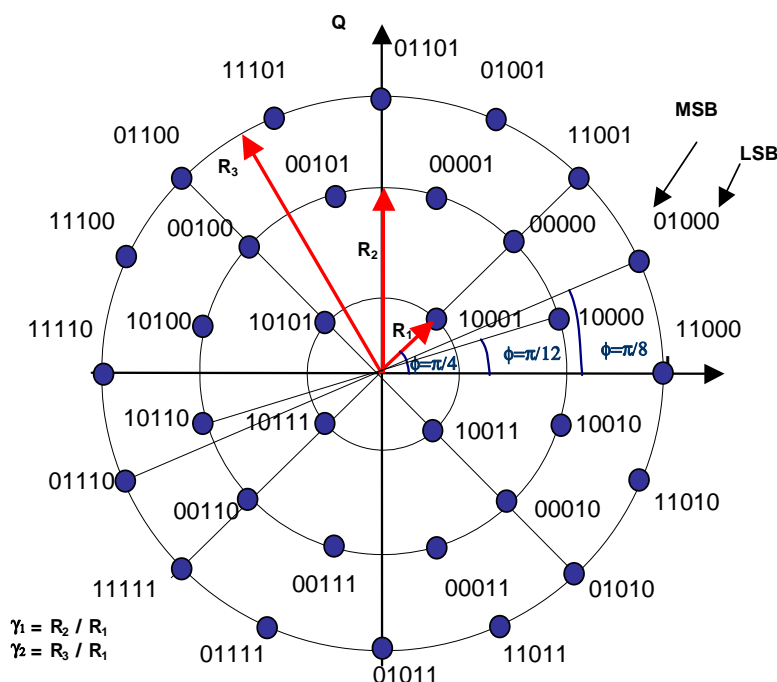

Figure 12: 32APSK signal constellation

Table 10: optimum constellation radius ratios γ_1 and γ_2 (linear channel) for 32 APSK

Code rate	Modulation/coding spectral efficiency	γ_1	γ_2
3/4	3,74	2,84	5,27
4/5	3,99	2,72	4,87
5/6	4,15	2,64	4,64
8/9	4,43	2,54	4,33
9/10	4,49	2,53	4,30

5.5 Physical Layer (PL) framing

The PLFraming sub-system shall generate a physical layer frame (named PLFRAME) by performing the following processes (see figures 1 and 13):

- Dummy PLFRAME generation when no XFECFRAME is ready to be processed and transmitted.
- XFECFRAME slicing into an integer number S of constant length SLOTS (length: $M = 90$ symbols each); S shall be according to table 11.
- PLHEADER generation and insertion before the XFECFRAME for receiver configuration. PLHEADER shall occupy exactly one SLOT (length: $M = 90$ Symbols).
- Pilot Block insertion (for modes requiring pilots) every 16 SLOTS, to help receiver synchronization. The Pilot Block shall be composed of $P = 36$ pilot symbols.
- Randomization of the (I, Q) modulated symbols by means of a physical layer scrambler.

The input stream of the sub-system shall be a XFECFRAME and the output a scrambled PLFRAME.

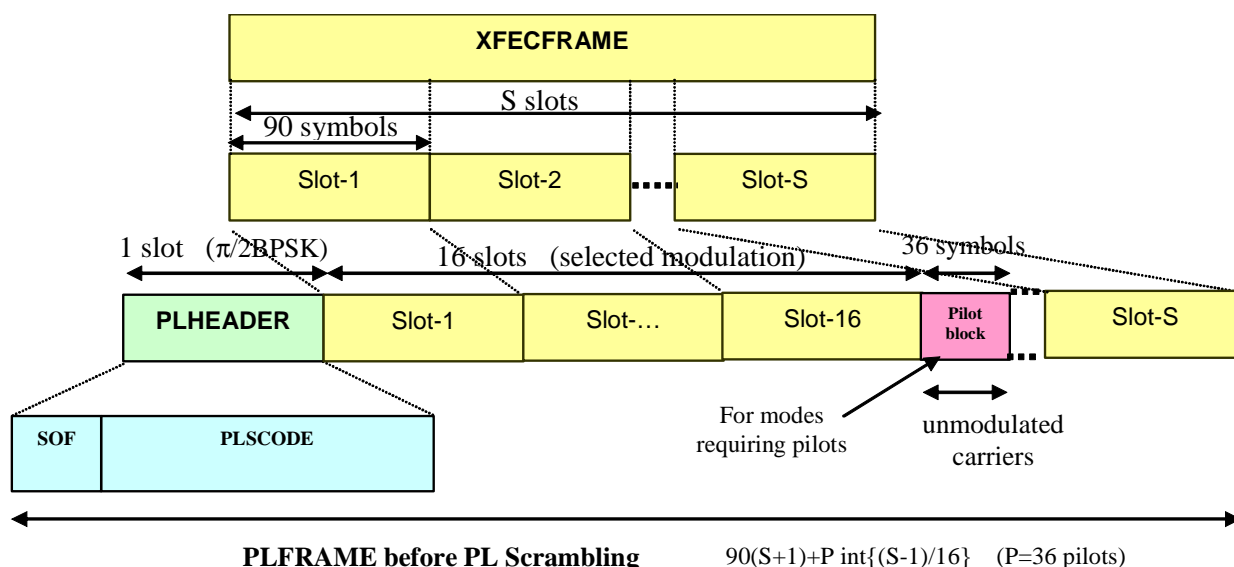

Figure 13: Format of a "Physical Layer Frame" PLFRAME

Table 11: S = number of SLOTS (M = 90 symbols) per XFECFRAME

η_{MOD} (bit/s/Hz)	$n_{\text{ldpc}} = 64\ 800$ (normal frame)		$n_{\text{ldpc}} = 16\ 200$ (short frame)	
	S	η % no-pilot	S	η % no-pilot
2	360	99,72	90	98,90
3	240	99,59	60	98,36
4	180	99,45	45	97,83
5	144	99,31	36	97,30

The PLFRAMING efficiency is $\eta = 90S / [90(S+1) + P \text{int}\{(S-1)/16\}]$, where $P = 36$ and $\text{int}\{\cdot\}$ is the integer function.

5.5.1 Dummy PLFRAME insertion

A Dummy PLFRAME shall be composed of a PLHEADER (see clause 5.5.2) and of 36 SLOTS of un-modulated carriers ($I = (1/\sqrt{2})$, $Q = (1/\sqrt{2})$).

5.5.2 PL signalling

The PLHEADER is intended for receiver synchronization and physical layer signalling.

NOTE: After decoding the PLHEADER, the receiver knows the PLFRAME duration and structure, the modulation and coding scheme of the XFECFRAME, the presence or absence of pilot symbols.

The PLHEADER (one SLOT of 90 symbols) shall be composed of the following fields:

- **SOF** (26 symbols), identifying the Start of Frame.
- **PLS** code (64 symbol): PLS (Physical Layer Signalling) code shall be a non-systematic binary code of length 64 and dimension 7 with minimum distance $d_{\text{min}} = 32$. It is equivalent to the first order Reed-Muller under permutation. It transmits 7 bits for physical layer signalling purpose. These 7 bits consists of two fields: MODCOD and TYPE defined as follows:
 - MODCOD (5 symbols), identifying the XFECFRAME modulation and FEC rate;
 - TYPE (2 symbols), identifying the FECFRAME length (64 800 bits or 16 200 bits) and the presence/absence of pilots.

The PLHEADER, represented by the binary sequence $(y_1, y_2, \dots, y_{90})$ shall be modulated into $90 \pi/2$ BPSK symbols according to the rule:

$$I_{2i-1} = Q_{2i-1} = (1/\sqrt{2}) (1-2y_{2i-1}), I_{2i} = -Q_{2i} = - (1/\sqrt{2}) (1-2y_{2i}) \text{ for } i = 1, 2, \dots, 45$$

5.5.2.1 SOF field

SOF shall correspond to the sequence $18D2E82_{\text{HEX}}$ (01-1000-....-0010 in binary notation, the left-side bit being the MSB of the PLHEADER).

5.5.2.2 MODCOD field

MODCOD shall correspond to 5 bits, identifying code rates in the set $\eta_C = [1/4, 1/3, 2/5, 1/2, 3/5, 2/3, 3/4, 4/5, 5/6, 8/9, 9/10]$ and modulations in the set of spectrum efficiencies $\eta_{\text{MOD}} = [2, 3, 4, 5]$ according to table 12.

Table 12: MODCOD coding

Mode	MOD COD	Mode	MOD COD	Mode	MOD COD	Mode	MOD COD
QPSK 1/4	1 _D	QPSK 5/6	9 _D	8PSK 9/10	17 _D	32APSK 4/5	25 _D
QPSK 1/3	2 _D	QPSK 8/9	10 _D	16APSK 2/3	18 _D	32APSK 5/6	26 _D
QPSK 2/5	3 _D	QPSK 9/10	11 _D	16APSK 3/4	19 _D	32APSK 8/9	27 _D
QPSK 1/2	4 _D	8PSK 3/5	12 _D	16APSK 4/5	20 _D	32APSK 9/10	28 _D
QPSK 3/5	5 _D	8PSK 2/3	13 _D	16APSK 5/6	21 _D	Reserved	29 _D
QPSK 2/3	6 _D	8PSK 3/4	14 _D	16APSK 8/9	22 _D	Reserved	30 _D
QPSK 3/4	7 _D	8PSK 5/6	15 _D	16APSK 9/10	23 _D	Reserved	31 _D
QPSK 4/5	8 _D	8PSK 8/9	16 _D	32APSK 3/4	24 _D	DUMMY PLFRAME	0 _D

5.5.2.3 TYPE field

The MSB of the TYPE field shall identify 2 FECFRAME sizes (0 = normal: 64 800 bits; 1 = short: 16 200 bits). The LSB of the TYPE field shall identify the pilot configurations (see clause 5.5.3) (0 = no pilots, 1 = pilots).

5.5.2.4 PLS code

The MODCODE and TYPE fields are bi-orthogonally coded with a (64,7) code. Such code is constructed starting from a bi-orthogonal (32,6) code according to the construction in figure 13a.

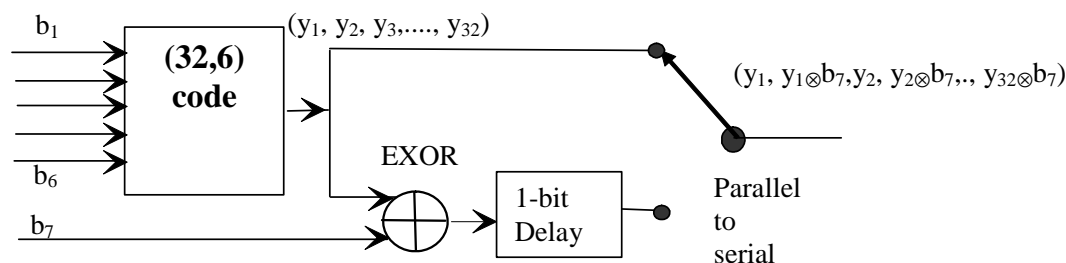

Figure 13a: (the symbol \otimes stands for binary EXOR)

The particular construction guarantees that each odd bit in the (64,7) code is either always equal to the previous one or is always the opposite. Which of the two hypotheses is true depends on the bit b_7 . This fact can be exploited in case differentially coherent detection is adopted in the receiver.

The MODCOD and the MSB of the TYPE field shall be encoded by a linear block code of length 32 with the following generator matrix.

$$\mathbf{G} = \begin{bmatrix}
 01010101010101010101010101010101 \\
 00110011001100110011001100110011 \\
 00001111000011110000111100001111 \\
 00000000111111110000000011111111 \\
 00000000000000001111111111111111 \\
 11111111111111111111111111111111
 \end{bmatrix}$$

Figure 13b

The most significant bit of the MODCOD is multiplied with the first row of the matrix, the following bit with the second row and so on. The 32 coded bits is denoted as $(y_1 y_2 \dots y_{32})$. When the least significant bit of the TYPE field is 0, the final PLS code will generate $(y_1 y_1 y_2 y_2 \dots y_{32} y_{32})$ as the output, i.e. each symbol shall be repeated. When the least significant bit of the TYPE field is 1, the final PLS code will generate $(y_1 \bar{y}_1 y_2 \bar{y}_2 \dots y_{32} \bar{y}_{32})$ as output, i.e. the repeated symbol is further binary complemented. The 64 bits output of the PLS code is further scrambled by the binary sequence:

0111000110011101100000111100100101010011010000100010110111111010.

5.5.3 Pilots insertion

Two PLFRAME configurations shall be possible:

- Without pilots.
- With pilots.

In this latter case a PILOT BLOCK shall be composed of $P = 36$ pilot symbols. Each pilot shall be an un-modulated symbol, identified by $I = (1/\sqrt{2})$, $Q = (1/\sqrt{2})$. The first PILOT BLOCK shall be inserted 16 SLOTS after the PLHEADER, the second after 32 SLOTS and so on, as represented in figure 13. If the PILOT BLOCK position coincides with the beginning of the next SOF, then the PILOT BLOCK is not transmitted.

The pilot presence/absence in VCM and ACM can be changed on a frame-by-frame basis.

5.5.4 Physical layer scrambling

Prior to modulation, each PLFRAME, excluding the PLHEADER, shall be randomized for energy dispersal by multiplying the $(I+jQ)$ samples by a complex randomization sequence $(C_I + jC_Q)$:

$$I_{\text{SCRAMBLED}} = [I C_I - Q C_Q]; \quad Q_{\text{SCRAMBLED}} = (I C_Q + Q C_I)$$

NOTE: The randomization sequence rate corresponds to the I-Q PLFRAME symbol rate, thus it has no impact on the occupied signal bandwidth. The randomization sequence has a period greater than the maximum required duration of about 70 000 symbols).

The randomization sequence shall be reinitialized at the end of each PLHEADER (see figure 14). The PLFRAME duration depends on the modulation selected, thus the randomization sequence length shall be truncated to the current PLFRAME length.

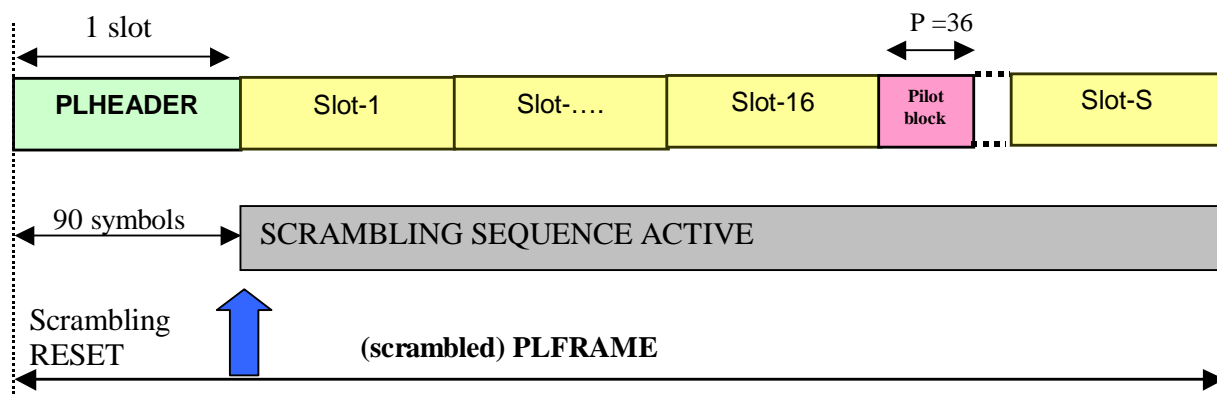

Figure 14: PL SCRAMBLING

The scrambling code sequences shall be constructed by combining two real m -sequences (generated by means of two generator polynomials of degree 18) into a complex sequence. The resulting sequences thus constitute segments of a set of Gold sequences.

Let x and y be the two sequences respectively. The x sequence is constructed using the primitive (over $GF(2)$) polynomial $1+x^7+x^{18}$. The y sequence is constructed using the polynomial $1+y^5+y^7+y^{10}+y^{18}$.

The sequence depending on the chosen scrambling code number n is denoted z_n in the sequel. Furthermore, let $x(i)$, $y(i)$ and $z_n(i)$ denote the i^{th} symbol of the sequence x , y , and z_n respectively. The m -sequences x and y are constructed as:

- Initial conditions:
 - x is constructed with $x(0) = 1$, $x(1) = x(2) = \dots = x(16) = x(17) = 0$.
 - $y(0) = y(1) = \dots = y(16) = y(17) = 1$.
- Recursive definition of subsequent symbols:
 - $x(i+18) = x(i+7) + x(i)$ modulo 2, $i = 0, \dots, 2^{18} - 20$.
 - $y(i+18) = y(i+10) + y(i+7) + y(i+5) + y(i)$ modulo 2, $i = 0, \dots, 2^{18} - 20$.

The n^{th} Gold code sequence z_n $n = 0, 1, 2, \dots, 2^{18}-2$, is then defined as:

$$z_n(i) = [x((i+n) \text{ modulo } (2^{18}-1)) + y(i)] \text{ modulo } 2, i = 0, \dots, 2^{18} - 2.$$

These binary sequences are converted to integer valued sequences R_n (R_n assuming values 0, 1, 2, 3) by the following transformation:

$$R_n(i) = 2 z_n((i + 131\,072) \text{ modulo } (2^{18}-1)) + z_n(i) \quad i = 0, 1, \dots, 66\,419.$$

Finally, the n^{th} complex scrambling code sequence $C_I(i) + jC_Q(i)$ is defined as:

$$C_I(i) + jC_Q(i) = \exp(j R_n(i) \pi/2)$$

R_n	$\exp(j R_n \pi/2)$	$I_{\text{scrambled}}$	$Q_{\text{scrambled}}$
0	1	I	Q
1	j	-Q	I
2	-1	-I	-Q
3	-j	Q	-I

Figure 15 gives a possible block diagram for PL scrambling sequences generation for $n = 0$.

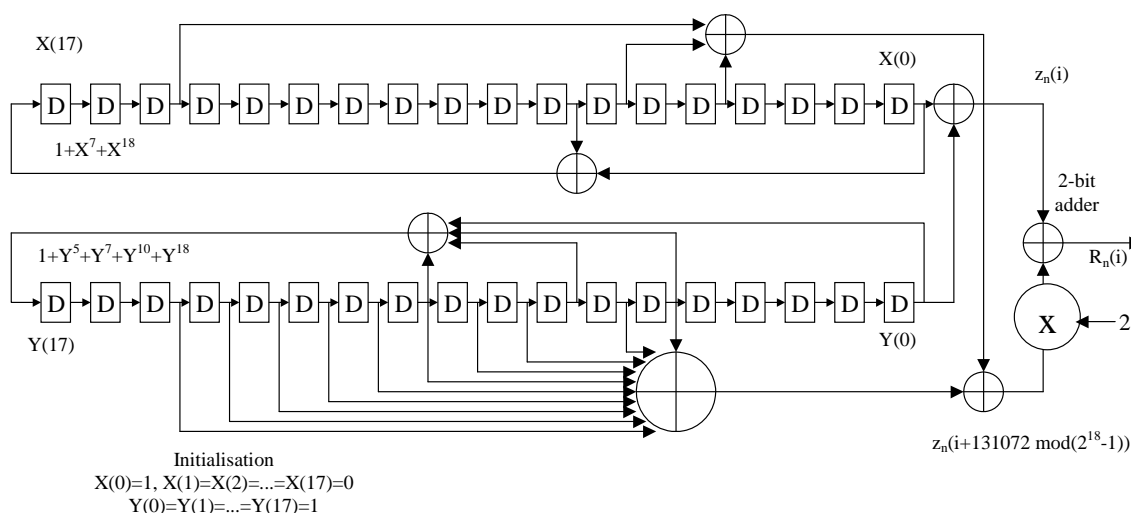

Figure 15: Configuration of PL scrambling code generator for $n = 0$

In case of broadcasting services, $n = 0$ shall be used as default sequence, to avoid manual receiver setting or synchronization delays.

NOTE: n , assuming values in the range 0 to 262 141, indicates the spreading sequence number. The use of different PL Scrambling sequences allows a reduction of interference correlation between different services. For the same purpose, it is possible to reuse a shifted version of the same sequence in different satellite beams. Furthermore n can be unequivocally associated to each satellite operator or satellite or transponder, thus permitting identification of an interfering signal via the PL Scrambling "signature" detection. There is no explicit signalling method to convey n to the receiver.

5.6 Baseband shaping and quadrature modulation

After randomization, the signals shall be square root raised cosine filtered. The roll-off factor shall be $\alpha = 0,35, 0,25$ and $0,20$, depending on the service requirements.

The baseband square root raised cosine filter shall have a theoretical function defined by the following expression:

$$H(f) = 1 \quad \text{for } |f| < f_N(1 - \alpha)$$

$$H(f) = \left\{ \frac{1}{2} + \frac{1}{2} \sin \frac{\pi}{2f_N} \left[\frac{f_N - |f|}{\alpha} \right] \right\}^{1/2} \quad \text{for } f_N(1 - \alpha)$$

$$H(f) = 0 \quad \text{for } |f| > f_N(1 + \alpha),$$

where: $f_N = \frac{1}{2T_s} = \frac{R_s}{2}$ is the Nyquist frequency and α is the roll-off factor.

A template for the signal spectrum at the modulator output is given in annex A.

Quadrature modulation shall be performed by multiplying the in-phase and quadrature samples (after baseband filtering) by $\sin(2\pi f_0 t)$ and $\cos(2\pi f_0 t)$, respectively (where f_0 is the carrier frequency). The two resulting signals shall be added to obtain the modulator output signal.

6 Error performance

Table 13 summarizes performance requirements at QEF over AWGN (E_s = average energy per transmitted symbol). Ideal E_s/N_0 (dB) is the figure achieved by computer simulation, 50 LDPC fixed point decoding iterations (see annex G), perfect carrier and synchronization recovery, no phase noise, AWGN channel. For short FECFRAMEs an additional degradation of 0,2 dB to 0,3 dB has to be taken into account.

For calculating link budgets, specific satellite channel impairments should be taken into account.

PER is the ratio between the useful transport stream packets (188 bytes) correctly received and affected by errors, after forward error correction.

Table 13: E_s/N_0 performance at Quasi Error Free PER = 10^{-7} (AWGN channel)

Mode	Spectral efficiency	Ideal E_s/N_0 (dB) for FECFRAME length = 64 800
QPSK 1/4	0,490243	-2,35
QPSK 1/3	0,656448	-1,24
QPSK 2/5	0,789412	-0,30
QPSK 1/2	0,988858	1,00
QPSK 3/5	1,188304	2,23
QPSK 2/3	1,322253	3,10
QPSK 3/4	1,487473	4,03
QPSK 4/5	1,587196	4,68
QPSK 5/6	1,654663	5,18
QPSK 8/9	1,766451	6,20
QPSK 9/10	1,788612	6,42
8PSK 3/5	1,779991	5,50
8PSK 2/3	1,980636	6,62
8PSK 3/4	2,228124	7,91
8PSK 5/6	2,478562	9,35
8PSK 8/9	2,646012	10,69
8PSK 9/10	2,679207	10,98
16APSK 2/3	2,637201	8,97
16APSK 3/4	2,966728	10,21
16APSK 4/5	3,165623	11,03
16APSK 5/6	3,300184	11,61
16APSK 8/9	3,523143	12,89
16APSK 9/10	3,567342	13,13
32APSK 3/4	3,703295	12,73
32APSK 4/5	3,951571	13,64
32APSK 5/6	4,119540	14,28
32APSK 8/9	4,397854	15,69
32APSK 9/10	4,453027	16,05
NOTE:	Given the system spectral efficiency η_{tot} the ratio between the energy per information bit and single sided noise power spectral density $E_b/N_0 = E_s/N_0 - 10\log_{10}(\eta_{tot})$.	

Spectral efficiencies (per unit symbol rate) are computed for normal FECFRAME length and no pilots.

Examples of possible use of the System are given in annex H. Table H.1 gives examples of possible degradation introduced by the satellite channel model described in clause H.7.

Annex A (normative): Signal spectrum at the modulator output

For roll-off factor $\alpha = 0,35$, the signal spectrum at the modulator output shall be in accordance with EN 300 421 [2].

As an option, the signal spectrum can correspond to a narrower roll-off factor $\alpha = 0,25$ or $\alpha = 0,20$.

Figure A.1 gives a template for the signal spectrum at the modulator output.

Figure A.1 also represents a possible mask for a hardware implementation of the Nyquist modulator filter. The points A to S shown on figures A.1 and A.2 are defined in table A.1. The mask for the filter frequency response is based on the assumption of ideal Dirac delta input signals, spaced by the symbol period $T_S = 1/R_S = 1/2f_N$ while in the case of rectangular input signals a suitable $x/\sin x$ correction shall be applied on the filter response.

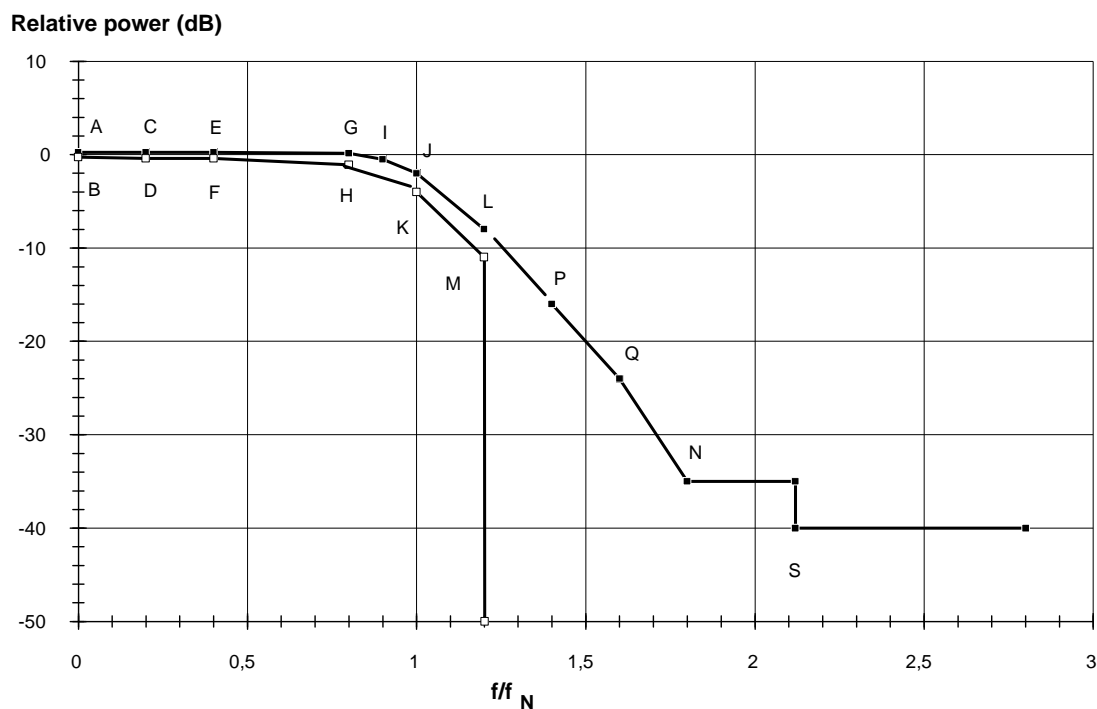

Figure A.1: Template for the signal spectrum mask at the modulator output represented in the baseband frequency domain, the frequency axis is calibrated for roll-off factor $\alpha = 0,35$

Figure A.2 gives a mask for the group delay for the hardware implementation of the Nyquist modulator filter.

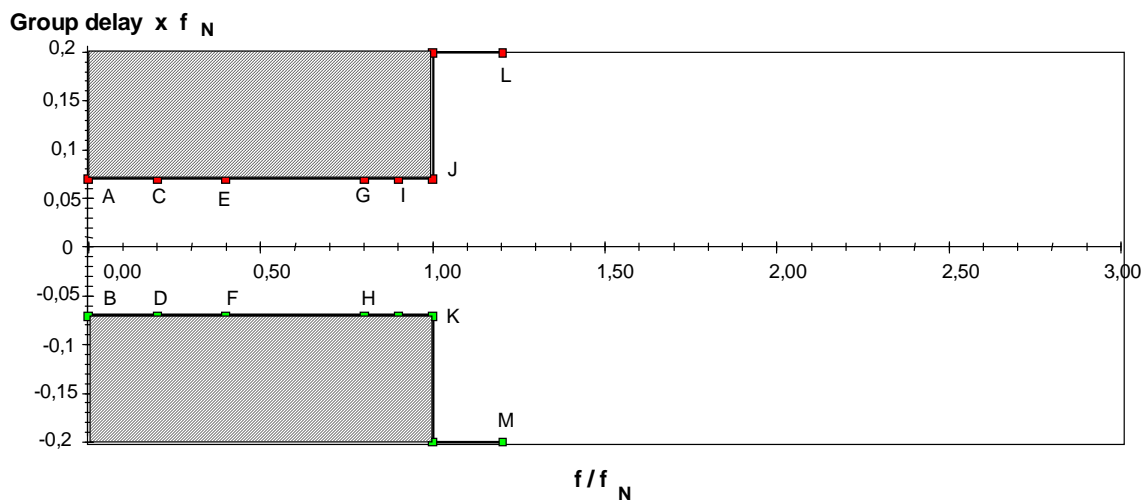

Figure A.2: Template of the modulator filter group delay

Table A.1: Definition of points given in figures A.1 and A.2

Point	Frequency for $\alpha = 0,35$	Frequency for $\alpha = 0,25$	Frequency for $\alpha = 0,20$	Relative power (dB)	Group delay
A	$0,0 f_N$	$0,0 f_N$	$0,0 f_N$	+0,25	$+0,07 / f_N$
B	$0,0 f_N$	$0,0 f_N$	$0,0 f_N$	-0,25	$-0,07 / f_N$
C	$0,2 f_N$	$0,2 f_N$	$0,2 f_N$	+0,25	$+0,07 / f_N$
D	$0,2 f_N$	$0,2 f_N$	$0,2 f_N$	-0,40	$-0,07 / f_N$
E	$0,4 f_N$	$0,4 f_N$	$0,4 f_N$	+0,25	$+0,07 / f_N$
F	$0,4 f_N$	$0,4 f_N$	$0,4 f_N$	-0,40	$-0,07 / f_N$
G	$0,8 f_N$	$0,86 f_N$	$0,89 f_N$	+0,15	$+0,07 / f_N$
H	$0,8 f_N$	$0,86 f_N$	$0,89 f_N$	-1,10	$-0,07 / f_N$
I	$0,9 f_N$	$0,93 f_N$	$0,94 f_N$	-0,50	$+0,07 / f_N$
J	$1,0 f_N$	$1,0 f_N$	$1,0 f_N$	-2,00	$+0,07 / f_N$
K	$1,0 f_N$	$1,0 f_N$	$1,0 f_N$	-4,00	$-0,07 / f_N$
L	$1,2 f_N$	$1,13 f_N$	$1,11 f_N$	-8,00	-
M	$1,2 f_N$	$1,13 f_N$	$1,11 f_N$	-11,00	-
N	$1,8 f_N$	$1,60 f_N$	$1,5 f_N$	-35,00	-
P	$1,4 f_N$	$1,30 f_N$	$1,23 f_N$	-16,00	-
Q	$1,6 f_N$	$1,45 f_N$	$1,4 f_N$	-24,00	-
S	$2,12 f_N$	$1,83 f_N$	$1,7 f_N$	-40,00	-

Annex B (normative): Addresses of parity bit accumulators for $n_{\text{ldpc}} = 64\ 800$

Example of interpretation of the table B.4.

$$p_{54} = p_{54} \oplus i_0 \quad p_{9318} = p_{9318} \oplus i_0 \quad p_{14392} = p_{14392} \oplus i_0 \quad p_{27561} = p_{27561} \oplus i_0 \quad p_{26909} = p_{26909} \oplus i_0 \quad p_{10219} = p_{10219} \oplus i_0$$

$$p_{2534} = p_{2534} \oplus i_0 \quad p_{8597} = p_{8597} \oplus i_0$$

$$p_{144} = p_{144} \oplus i_1 \quad p_{9408} = p_{9408} \oplus i_1 \quad p_{14482} = p_{14482} \oplus i_1 \quad p_{27651} = p_{27651} \oplus i_1 \quad p_{26999} = p_{26999} \oplus i_1 \quad p_{10309} = p_{10309} \oplus i_1$$

$$p_{2624} = p_{2624} \oplus i_1 \quad p_{8687} = p_{8687} \oplus i_1$$

: : : : : : : :

: : : : : : : :

$$p_{32364} = p_{32364} \oplus i_{359} \quad p_{9228} = p_{9228} \oplus i_{359} \quad p_{14302} = p_{14302} \oplus i_{359} \quad p_{27471} = p_{27471} \oplus i_{359} \quad p_{26819} = p_{26819} \oplus i_{359}$$

$$p_{10129} = p_{10129} \oplus i_{359} \quad p_{2444} = p_{2444} \oplus i_{359} \quad p_{8507} = p_{8507} \oplus i_{359}$$

$$p_{55} = p_{55} \oplus i_{360} \quad p_{7263} = p_{7263} \oplus i_{360} \quad p_{4635} = p_{4635} \oplus i_{360} \quad p_{2530} = p_{2530} \oplus i_{360} \quad p_{28130} = p_{28130} \oplus i_{360}$$

$$p_{3033} = p_{3033} \oplus i_{360} \quad p_{23830} = p_{23830} \oplus i_{360} \quad p_{3651} = p_{3651} \oplus i_{360}$$

: : : : : : : :

: : : : : : : :

Table B.1: Rate 1/4 ($n_{\text{ldpc}} = 64\ 800$)

23606 36098 1140 28859 18148 18510 6226 540 42014 20879 23802 47088	36046 32914 11836
16419 24928 16609 17248 7693 24997 42587 16858 34921 21042 37024 20692	7304 39782 33721
1874 40094 18704 14474 14004 11519 13106 28826 38669 22363 30255 31105	16905 29962 12980
22254 40564 22645 22532 6134 9176 39998 23892 8937 15608 16854 31009	11171 23709 22460
8037 40401 13550 19526 41902 28782 13304 32796 24679 27140 45980 10021	34541 9937 44500
40540 44498 13911 22435 32701 18405 39929 25521 12497 9851 39223 34823	14035 47316 8815
15233 45333 5041 44979 45710 42150 19416 1892 23121 15860 8832 10308	15057 45482 24461
10468 44296 3611 1480 37581 32254 13817 6883 32892 40258 46538 11940	30518 36877 879
6705 21634 28150 43757 895 6547 20970 28914 30117 25736 41734 11392	7583 13364 24332
22002 5739 27210 27828 34192 37992 10915 6998 3824 42130 4494 35739	448 27056 4682
8515 1191 13642 30950 25943 12673 16726 34261 31828 3340 8747 39225	12083 31378 21670
18979 17058 43130 4246 4793 44030 19454 29511 47929 15174 24333 19354	1159 18031 2221
16694 8381 29642 46516 32224 26344 9405 18292 12437 27316 35466 41992	17028 38715 9350
15642 5871 46489 26723 23396 7257 8974 3156 37420 44823 35423 13541	17343 24530 29574
42858 32008 41282 38773 26570 2702 27260 46974 1469 20887 27426 38553	46128 31039 32818
22152 24261 8297	20373 36967 18345
19347 9978 27802	46685 20622 32806
34991 6354 33561	
29782 30875 29523	
9278 48512 14349	
38061 4165 43878	
8548 33172 34410	
22535 28811 23950	
20439 4027 24186	
38618 8187 30947	
35538 43880 21459	
7091 45616 15063	
5505 9315 21908	

Table B.2: Rate 1/3 ($n_{ldpc} = 64\ 800$)

34903 20927 32093 1052 25611 16093 16454 5520 506 37399 18518 21120	29094 5357 19224
11636 14594 22158 14763 15333 6838 22222 37856 14985 31041 18704 32910	9562 24436 28637
17449 1665 35639 16624 12867 12449 10241 11650 25622 34372 19878 26894	40177 2326 13504
29235 19780 36056 20129 20029 5457 8157 35554 21237 7943 13873 14980	6834 21583 42516
9912 7143 35911 12043 17360 37253 25588 11827 29152 21936 24125 40870	40651 42810 25709
40701 36035 39556 12366 19946 29072 16365 35495 22686 11106 8756 34863	31557 32138 38142
19165 15702 13536 40238 4465 40034 40590 37540 17162 1712 20577 14138	18624 41867 39296
31338 19342 9301 39375 3211 1316 33409 28670 12282 6118 29236 35787	37560 14295 16245
11504 30506 19558 5100 24188 24738 30397 33775 9699 6215 3397 37451	6821 21679 31570
34689 23126 7571 1058 12127 27518 23064 11265 14867 30451 28289 2966	25339 25083 22081
11660 15334 16867 15160 38343 3778 4265 39139 17293 26229 42604 13486	8047 697 35268
31497 1365 14828 7453 26350 41346 28643 23421 8354 16255 11055 24279	9884 17073 19995
15687 12467 13906 5215 41328 23755 20800 6447 7970 2803 33262 39843	26848 35245 8390
5363 22469 38091 28457 36696 34471 23619 2404 24229 41754 1297 18563	18658 16134 14807
3673 39070 14480 30279 37483 7580 29519 30519 39831 20252 18132 20010	12201 32944 5035
34386 7252 27526 12950 6875 43020 31566 39069 18985 15541 40020 16715	25236 1216 38986
1721 37332 39953 17430 32134 29162 10490 12971 28581 29331 6489 35383	42994 24782 8681
736 7022 42349 8783 6767 11871 21675 10325 11548 25978 431 24085	28321 4932 34249
1925 10602 28585 12170 15156 34404 8351 13273 20208 5800 15367 21764	4107 29382 32124
16279 37832 34792 21250 34192 7406 41488 18346 29227 26127 25493 7048	22157 2624 14468
39948 28229 24899	38788 27081 7936
17408 14274 38993	4368 26148 10578
38774 15968 28459	25353 4122 39751
41404 27249 27425	
41229 6082 43114	
13957 4979 40654	
3093 3438 34992	
34082 6172 28760	
42210 34141 41021	
14705 17783 10134	
41755 39884 22773	
14615 15593 1642	
29111 37061 39860	
9579 33552 633	
12951 21137 39608	
38244 27361 29417	
2939 10172 36479	

Table B.3: Rate 2/5 ($n_{ldpc} = 64\ 800$)

31413 18834 28884 947 23050 14484 14809 4968 455 33659 16666 19008	25796 31795 12152	28229 31684 30160
13172 19939 13354 13719 6132 20086 34040 13442 27958 16813 29619 16553	12184 35088 31226	15293 8483 28002
1499 32075 14962 11578 11204 9217 10485 23062 30936 17892 24204 24885	38263 33386 24892	14880 13334 12584
32490 18086 18007 4957 7285 32073 19038 7152 12486 13483 24808 21759	23114 37995 29796	28646 2558 19687
32321 10839 15620 33521 23030 10646 26236 19744 21713 36784 8016 12869	34336 10551 36245	6259 4499 26336
35597 11129 17948 26160 14729 31943 20416 10000 7882 31380 27858 33356	35407 175 7203	11952 28386 8405
14125 12131 36199 4058 35992 36594 33698 15475 1566 18498 12725 7067	14654 38201 22605	10609 961 7582
17406 8372 35437 2888 1184 30068 25802 11056 5507 26313 32205 37232	28404 6595 1018	10423 13191 26818
15254 5365 17308 22519 35009 718 5240 16778 23131 24092 20587 33385	19932 3524 29305	15922 36654 21450
27455 17602 4590 21767 22266 27357 30400 8732 5596 3060 33703 3596	31749 20247 8128	10492 1532 1205
6882 873 10997 24738 20770 10067 13379 27409 25463 2673 6998 31378	18026 36357 26735	30551 36482 22153
15181 13645 34501 3393 3840 35227 15562 23615 38342 12139 19471 15483	7543 29767 13588	5156 11330 34243
13350 6707 23709 37204 25778 21082 7511 14588 10010 21854 28375 33591	13333 25965 8463	28616 35369 13322
12514 4695 37190 21379 18723 5802 7182 2529 29936 35860 28338 10835	14504 36796 19710	8962 1485 21186
34283 25610 33026 31017 21259 2165 21807 37578 1175 16710 21939 30841	4528 25299 7318	23541 17445 35561
27292 33730 6836 26476 27539 35784 18245 16394 17939 23094 19216 17432	35091 25550 14798	33133 11593 19895
11655 6183 38708 28408 35157 17089 13998 36029 15052 16617 5638 36464	7824 215 1248	33917 7863 33651
15693 28923 26245 9432 11675 25720 26405 5838 31851 26898 8090 37037	30848 5362 17291	20063 28331 10702
24418 27583 7959 35562 37771 17784 11382 11156 37855 7073 21685 34515	28932 30249 27073	13195 21107 21859
10977 13633 30969 7516 11943 18199 5231 13825 19589 23661 11150 35602	13062 2103 16206	4364 31137 4804
19124 30774 6670 37344 16510 26317 23518 22957 6348 34069 8845 20175	7129 32062 19612	5585 2037 4830
34985 14441 25668 4116 3019 21049 37308 24551 24727 20104 24850 12114	9512 21936 38833	30672 16927 14800
38187 28527 13108 13985 1425 21477 30807 8613 26241 33368 35913 32477	35849 33754 23450	
5903 34390 24641 26556 23007 27305 38247 2621 9122 32806 21554 18685	18705 28656 18111	
17287 27292 19033	22749 27456 32187	

Table B.4: Rate 1/2 ($n_{ldpc} = 64\ 800$)

54	9318	14392	27561	26909	10219	2534	8597	40	30051	30426
55	7263	4635	2530	28130	3033	23830	3651	41	1335	15424
56	24731	23583	26036	17299	5750	792	9169	42	6865	17742
57	5811	26154	18653	11551	15447	13685	16264	43	31779	12489
58	12610	11347	28768	2792	3174	29371	12997	44	32120	21001
59	16789	16018	21449	6165	21202	15850	3186	45	14508	6996
60	31016	21449	17618	6213	12166	8334	18212	46	979	25024
61	22836	14213	11327	5896	718	11727	9308	47	4554	21896
62	2091	24941	29966	23634	9013	15587	5444	48	7989	21777
63	22207	3983	16904	28534	21415	27524	25912	49	4972	20661
64	25687	4501	22193	14665	14798	16158	5491	50	6612	2730
65	4520	17094	23397	4264	22370	16941	21526	51	12742	4418
66	10490	6182	32370	9597	30841	25954	2762	52	29194	595
67	22120	22865	29870	15147	13668	14955	19235	53	19267	20113
68	6689	18408	18346	9918	25746	5443	20645			
69	29982	12529	13858	4746	30370	10023	24828			
70	1262	28032	29888	13063	24033	21951	7863			
71	6594	29642	31451	14831	9509	9335	31552			
72	1358	6454	16633	20354	24598	624	5265			
73	19529	295	18011	3080	13364	8032	15323			
74	11981	1510	7960	21462	9129	11370	25741			
75	9276	29656	4543	30699	20646	21921	28050			
76	15975	25634	5520	31119	13715	21949	19605			
77	18688	4608	31755	30165	13103	10706	29224			
78	21514	23117	12245	26035	31656	25631	30699			
79	9674	24966	31285	29908	17042	24588	31857			
80	21856	27777	29919	27000	14897	11409	7122			
81	29773	23310	263	4877	28622	20545	22092			
82	15605	5651	21864	3967	14419	22757	15896			
83	30145	1759	10139	29223	26086	10556	5098			
84	18815	16575	2936	24457	26738	6030	505			
85	30326	22298	27562	20131	26390	6247	24791			
86	928	29246	21246	12400	15311	32309	18608			
87	20314	6025	26689	16302	2296	3244	19613			
88	6237	11943	22851	15642	23857	15112	20947			
89	26403	25168	19038	18384	8882	12719	7093			
0	14567	24965								
1	3908	100								
2	10279	240								
3	24102	764								
4	12383	4173								
5	13861	15918								
6	21327	1046								
7	5288	14579								
8	28158	8069								
9	16583	11098								
10	16681	28363								
11	13980	24725								
12	32169	17989								
13	10907	2767								
14	21557	3818								
15	26676	12422								
16	7676	8754								
17	14905	20232								
18	15719	24646								
19	31942	8589								
20	19978	27197								
21	27060	15071								
22	6071	26649								
23	10393	11176								
24	9597	13370								
25	7081	17677								
26	1433	19513								
27	26925	9014								
28	19202	8900								
29	18152	30647								
30	20803	1737								
31	11804	25221								
32	31683	17783								
33	29694	9345								
34	12280	26611								
35	6526	26122								
36	26165	11241								
37	7666	26962								
38	16290	8480								
39	11774	10120								

Table B.5: Rate 3/5 ($n_{\text{ldpc}} = 64\ 800$)

22422 10282 11626 19997 11161 2922 3122 99 5625 17064 8270 179	25 6393 3725
25087 16218 17015 828 20041 25656 4186 11629 22599 17305 22515 6463	26 597 19968
11049 22853 25706 14388 5500 19245 8732 2177 13555 11346 17265 3069	27 5743 8084
16581 22225 12563 19717 23577 11555 25496 6853 25403 5218 15925 21766	28 6770 9548
16529 14487 7643 10715 17442 11119 5679 14155 24213 21000 1116 15620	29 4285 17542
5340 8636 16693 1434 5635 6516 9482 20189 1066 15013 25361 14243	30 13568 22599
18506 22236 20912 8952 5421 15691 6126 21595 500 6904 13059 6802	31 1786 4617
8433 4694 5524 14216 3685 19721 25420 9937 23813 9047 25651 16826	32 23238 11648
21500 24814 6344 17382 7064 13929 4004 16552 12818 8720 5286 2206	33 19627 2030
22517 2429 19065 2921 21611 1873 7507 5661 23006 23128 20543 19777	34 13601 13458
1770 4636 20900 14931 9247 12340 11008 12966 4471 2731 16445 791	35 13740 17328
6635 14556 18865 22421 22124 12697 9803 25485 7744 18254 11313 9004	36 25012 13944
19982 23963 18912 7206 12500 4382 20067 6177 21007 1195 23547 24837	37 22513 6687
756 11158 14646 20534 3647 17728 11676 11843 12937 4402 8261 22944	38 4934 12587
9306 24009 10012 11081 3746 24325 8060 19826 842 8836 2898 5019	39 21197 5133
7575 7455 25244 4736 14400 22981 5543 8006 24203 13053 1120 5128	40 22705 6938
3482 9270 13059 15825 7453 23747 3656 24585 16542 17507 22462 14670	41 7534 24633
15627 15290 4198 22748 5842 13395 23918 16985 14929 3726 25350 24157	42 24400 12797
24896 16365 16423 13461 16615 8107 24741 3604 25904 8716 9604 20365	43 21911 25712
3729 17245 18448 9862 20831 25326 20517 24618 13282 5099 14183 8804	44 12039 1140
16455 17646 15376 18194 25528 1777 6066 21855 14372 12517 4488 17490	45 24306 1021
1400 8135 23375 20879 8476 4084 12936 25536 22309 16582 6402 24360	46 14012 20747
25119 23586 128 4761 10443 22536 8607 9752 25446 15053 1856 4040	47 11265 15219
377 21160 13474 5451 17170 5938 10256 11972 24210 17833 22047 16108	48 4670 15531
13075 9648 24546 13150 23867 7309 19798 2988 16858 4825 23950 15125	49 9417 14359
20526 3553 11525 23366 2452 17626 19265 20172 18060 24593 13255 1552	50 2415 6504
18839 21132 20119 15214 14705 7096 10174 5663 18651 19700 12524 14033	51 24964 24690
4127 2971 17499 16287 22368 21463 7943 18880 5567 8047 23363 6797	52 14443 8816
10651 24471 14325 4081 7258 4949 7044 1078 797 22910 20474 4318	53 6926 1291
21374 13231 22985 5056 3821 23718 14178 9978 19030 23594 8895 25358	54 6209 20806
6199 22056 7749 13310 3999 23697 16445 22636 5225 22437 24153 9442	55 13915 4079
7978 12177 2893 20778 3175 8645 11863 24623 10311 25767 17057 3691	56 24410 13196
20473 11294 9914 22815 2574 8439 3699 5431 24840 21908 16088 18244	57 13505 6117
8208 5755 19059 8541 24924 6454 11234 10492 16406 10831 11436 9649	58 9869 8220
16264 11275 24953 2347 12667 19190 7257 7174 24819 2938 2522 11749	59 1570 6044
3627 5969 13862 1538 23176 6353 2855 17720 2472 7428 573 15036	60 25780 17387
0 18539 18661	61 20671 24913
1 10502 3002	62 24558 20591
2 9368 10761	63 12402 3702
3 12299 7828	64 8314 1357
4 15048 13362	65 20071 14616
5 18444 24640	66 17014 3688
6 20775 19175	67 19837 946
7 18970 10971	68 15195 12136
8 5329 19982	69 7758 22808
9 11296 18655	70 3564 2925
10 15046 20659	71 3434 7769
11 7300 22140	
12 22029 14477	
13 11129 742	
14 13254 13813	
15 19234 13273	
16 6079 21122	
17 22782 5828	
18 19775 4247	
19 1660 19413	
20 4403 3649	
21 13371 25851	
22 22770 21784	
23 10757 14131	
24 16071 21617	

Table B.6: Rate 2/3 ($n_{ldpc} = 64\ 800$)

0 10491 16043 506 12826 8065 8226 2767 240 18673 9279 10579 20928	4 9161 15642
1 17819 8313 6433 6224 5120 5824 12812 17187 9940 13447 13825 18483	5 10714 10153
2 17957 6024 8681 18628 12794 5915 14576 10970 12064 20437 4455 7151	6 11585 9078
3 19777 6183 9972 14536 8182 17749 11341 5556 4379 17434 15477 18532	7 5359 9418
4 4651 19689 1608 659 16707 14335 6143 3058 14618 17894 20684 5306	8 9024 9515
5 9778 2552 12096 12369 15198 16890 4851 3109 1700 18725 1997 15882	9 1206 16354
6 486 6111 13743 11537 5591 7433 15227 14145 1483 3887 17431 12430	10 14994 1102
7 20647 14311 11734 4180 8110 5525 12141 15761 18661 18441 10569 8192	11 9375 20796
8 3791 14759 15264 19918 10132 9062 10010 12786 10675 9682 19246 5454	12 15964 6027
9 19525 9485 7777 19999 8378 9209 3163 20232 6690 16518 716 7353	13 14789 6452
10 4588 6709 20202 10905 915 4317 11073 13576 16433 368 3508 21171	14 8002 18591
11 14072 4033 19959 12608 631 19494 14160 8249 10223 21504 12395 4322	15 14742 14089
12 13800 14161	16 253 3045
13 2948 9647	17 1274 19286
14 14693 16027	18 14777 2044
15 20506 11082	19 13920 9900
16 1143 9020	20 452 7374
17 13501 4014	21 18206 9921
18 1548 2190	22 6131 5414
19 12216 21556	23 10077 9726
20 2095 19897	24 12045 5479
21 4189 7958	25 4322 7990
22 15940 10048	26 15616 5550
23 515 12614	27 15561 10661
24 8501 8450	28 20718 7387
25 17595 16784	29 2518 18804
26 5913 8495	30 8984 2600
27 16394 10423	31 6516 17909
28 7409 6981	32 11148 98
29 6678 15939	33 20559 3704
30 20344 12987	34 7510 1569
31 2510 14588	35 16000 11692
32 17918 6655	36 9147 10303
33 6703 19451	37 16650 191
34 496 4217	38 15577 18685
35 7290 5766	39 17167 20917
36 10521 8925	40 4256 3391
37 20379 11905	41 20092 17219
38 4090 5838	42 9218 5056
39 19082 17040	43 18429 8472
40 20233 12352	44 12093 20753
41 19365 19546	45 16345 12748
42 6249 19030	46 16023 11095
43 11037 19193	47 5048 17595
44 19760 11772	48 18995 4817
45 19644 7428	49 16483 3536
46 16076 3521	50 1439 16148
47 11779 21062	51 3661 3039
48 13062 9682	52 19010 18121
49 8934 5217	53 8968 11793
50 11087 3319	54 13427 18003
51 18892 4356	55 5303 3083
52 7894 3898	56 531 16668
53 5963 4360	57 4771 6722
54 7346 11726	58 5695 7960
55 5182 5609	59 3589 14630
56 2412 17295	
57 9845 20494	
58 6687 1864	
59 20564 5216	
0 18226 17207	
1 9380 8266	
2 7073 3065	
3 18252 13437	

Table B.7: Rate 3/4 ($n_{ldpc} = 64\ 800$)

0 6385 7901 14611 13389 11200 3252 5243 2504 2722 821 7374	24 2655 14957
1 11359 2698 357 13824 12772 7244 6752 15310 852 2001 11417	25 5565 6332
2 7862 7977 6321 13612 12197 14449 15137 13860 1708 6399 13444	26 4303 12631
3 1560 11804 6975 13292 3646 3812 8772 7306 5795 14327 7866	27 11653 12236
4 7626 11407 14599 9689 1628 2113 10809 9283 1230 15241 4870	28 16025 7632
5 1610 5699 15876 9446 12515 1400 6303 5411 14181 13925 7358	29 4655 14128
6 4059 8836 3405 7853 7992 15336 5970 10368 10278 9675 4651	30 9584 13123
7 4441 3963 9153 2109 12683 7459 12030 12221 629 15212 406	31 13987 9597
8 6007 8411 5771 3497 543 14202 875 9186 6235 13908 3563	32 15409 12110
9 3232 6625 4795 546 9781 2071 7312 3399 7250 4932 12652	33 8754 15490
10 8820 10088 11090 7069 6585 13134 10158 7183 488 7455 9238	34 7416 15325
11 1903 10818 119 215 7558 11046 10615 11545 14784 7961 15619	35 2909 15549
12 3655 8736 4917 15874 5129 2134 15944 14768 7150 2692 1469	36 2995 8257
13 8316 3820 505 8923 6757 806 7957 4216 15589 13244 2622	37 9406 4791
14 14463 4852 15733 3041 11193 12860 13673 8152 6551 15108 8758	38 11111 4854
15 3149 11981	39 2812 8521
16 13416 6906	40 8476 14717
17 13098 13352	41 7820 15360
18 2009 14460	42 1179 7939
19 7207 4314	43 2357 8678
20 3312 3945	44 7703 6216
21 4418 6248	0 3477 7067
22 2669 13975	1 3931 13845
23 7571 9023	2 7675 12899
24 14172 2967	3 1754 8187
25 7271 7138	4 7785 1400
26 6135 13670	5 9213 5891
27 7490 14559	6 2494 7703
28 8657 2466	7 2576 7902
29 8599 12834	8 4821 15682
30 3470 3152	9 10426 11935
31 13917 4365	10 1810 904
32 6024 13730	11 11332 9264
33 10973 14182	12 11312 3570
34 2464 13167	13 14916 2650
35 5281 15049	14 7679 7842
36 1103 1849	15 6089 13084
37 2058 1069	16 3938 2751
38 9654 6095	17 8509 4648
39 14311 7667	18 12204 8917
40 15617 8146	19 5749 12443
41 4588 11218	20 12613 4431
42 13660 6243	21 1344 4014
43 8578 7874	22 8488 13850
44 11741 2686	23 1730 14896
0 1022 1264	24 14942 7126
1 12604 9965	25 14983 8863
2 8217 2707	26 6578 8564
3 3156 11793	27 4947 396
4 354 1514	28 297 12805
5 6978 14058	29 13878 6692
6 7922 16079	30 11857 11186
7 15087 12138	31 14395 11493
8 5053 6470	32 16145 12251
9 12687 14932	33 13462 7428
10 15458 1763	34 14526 13119
11 8121 1721	35 2535 11243
12 12431 549	36 6465 12690
13 4129 7091	37 6872 9334
14 1426 8415	38 15371 14023
15 9783 7604	39 8101 10187
16 6295 11329	40 11963 4848
17 1409 12061	41 15125 6119
18 8065 9087	42 8051 14465
19 2918 8438	43 11139 5167
20 1293 14115	44 2883 14521
21 3922 13851	
22 3851 4000	
23 5865 1768	

Table B.8: Rate 4/5 ($n_{ldpc} = 64\ 800$)

0 149 11212 5575 6360 12559 8108 8505 408 10026 12828	3 6970 5447
1 5237 490 10677 4998 3869 3734 3092 3509 7703 10305	4 3217 5638
2 8742 5553 2820 7085 12116 10485 564 7795 2972 2157	5 8972 669
3 2699 4304 8350 712 2841 3250 4731 10105 517 7516	6 5618 12472
4 12067 1351 11992 12191 11267 5161 537 6166 4246 2363	7 1457 1280
5 6828 7107 2127 3724 5743 11040 10756 4073 1011 3422	8 8868 3883
6 11259 1216 9526 1466 10816 940 3744 2815 11506 11573	9 8866 1224
7 4549 11507 1118 1274 11751 5207 7854 12803 4047 6484	10 8371 5972
8 8430 4115 9440 413 4455 2262 7915 12402 8579 7052	11 266 4405
9 3885 9126 5665 4505 2343 253 4707 3742 4166 1556	12 3706 3244
10 1704 8936 6775 8639 8179 7954 8234 7850 8883 8713	13 6039 5844
11 11716 4344 9087 11264 2274 8832 9147 11930 6054 5455	14 7200 3283
12 7323 3970 10329 2170 8262 3854 2087 12899 9497 11700	15 1502 11282
13 4418 1467 2490 5841 817 11453 533 11217 11962 5251	16 12318 2202
14 1541 4525 7976 3457 9536 7725 3788 2982 6307 5997	17 4523 965
15 11484 2739 4023 12107 6516 551 2572 6628 8150 9852	18 9587 7011
16 6070 1761 4627 6534 7913 3730 11866 1813 12306 8249	19 2552 2051
17 12441 5489 8748 7837 7660 2102 11341 2936 6712 11977	20 12045 10306
18 10155 4210	21 11070 5104
19 1010 10483	22 6627 6906
20 8900 10250	23 9889 2121
21 10243 12278	24 829 9701
22 7070 4397	25 2201 1819
23 12271 3887	26 6689 12925
24 11980 6836	27 2139 8757
25 9514 4356	28 12004 5948
26 7137 10281	29 8704 3191
27 11881 2526	30 8171 10933
28 1969 11477	31 6297 7116
29 3044 10921	32 616 7146
30 2236 8724	33 5142 9761
31 9104 6340	34 10377 8138
32 7342 8582	35 7616 5811
33 11675 10405	0 7285 9863
34 6467 12775	1 7764 10867
35 3186 12198	2 12343 9019
0 9621 11445	3 4414 8331
1 7486 5611	4 3464 642
2 4319 4879	5 6960 2039
3 2196 344	6 786 3021
4 7527 6650	7 710 2086
5 10693 2440	8 7423 5601
6 6755 2706	9 8120 4885
7 5144 5998	10 12385 11990
8 11043 8033	11 9739 10034
9 4846 4435	12 424 10162
10 4157 9228	13 1347 7597
11 12270 6562	14 1450 112
12 11954 7592	15 7965 8478
13 7420 2592	16 8945 7397
14 8810 9636	17 6590 8316
	18 6838 9011
15 689 5430	19 6174 9410
16 920 1304	20 255 113
17 1253 11934	21 6197 5835
18 9559 6016	22 12902 3844
19 312 7589	23 4377 3505
20 4439 4197	24 5478 8672
21 4002 9555	25 4453 2132
22 12232 7779	26 9724 1380
23 1494 8782	27 12131 11526
24 10749 3969	28 12323 9511
25 4368 3479	29 8231 1752
26 6316 5342	30 497 9022
27 2455 3493	31 9288 3080
28 12157 7405	32 2481 7515
29 6598 11495	33 2696 268
30 11805 4455	34 4023 12341
31 9625 2090	35 7108 5553
32 4731 2321	
33 3578 2608	
34 8504 1849	
35 4027 1151	
0 5647 4935	
1 4219 1870	
2 10968 8054	

Table B.9: Rate 5/6 ($n_{\text{ldpc}} = 64\ 800$)

0 4362 416 8909 4156 3216 3112 2560 2912 6405 8593 4969 6723	14 7067 8878
1 2479 1786 8978 3011 4339 9313 6397 2957 7288 5484 6031 10217	15 9027 3415
2 10175 9009 9889 3091 4985 7267 4092 8874 5671 2777 2189 8716	16 1690 3866
3 9052 4795 3924 3370 10058 1128 9996 10165 9360 4297 434 5138	17 2854 8469
4 2379 7834 4835 2327 9843 804 329 8353 7167 3070 1528 7311	18 6206 630
5 3435 7871 348 3693 1876 6585 10340 7144 5870 2084 4052 2780	19 363 5453
6 3917 3111 3476 1304 10331 5939 5199 1611 1991 699 8316 9960	20 4125 7008
7 6883 3237 1717 10752 7891 9764 4745 3888 10009 4176 4614 1567	21 1612 6702
8 10587 2195 1689 2968 5420 2580 2883 6496 111 6023 1024 4449	22 9069 9226
9 3786 8593 2074 3321 5057 1450 3840 5444 6572 3094 9892 1512	23 5767 4060
10 8548 1848 10372 4585 7313 6536 6379 1766 9462 2456 5606 9975	24 3743 9237
11 8204 10593 7935 3636 3882 394 5968 8561 2395 7289 9267 9978	25 7018 5572
12 7795 74 1633 9542 6867 7352 6417 7568 10623 725 2531 9115	26 8892 4536
13 7151 2482 4260 5003 10105 7419 9203 6691 8798 2092 8263 3755	27 853 6064
14 3600 570 4527 200 9718 6771 1995 8902 5446 768 1103 6520	28 8069 5893
15 6304 7621	29 2051 2885
16 6498 9209	0 10691 3153
17 7293 6786	1 3602 4055
18 5950 1708	2 328 1717
19 8521 1793	3 2219 9299
20 6174 7854	4 1939 7898
21 9773 1190	5 617 206
22 9517 10268	6 8544 1374
23 2181 9349	7 10676 3240
24 1949 5560	8 6672 9489
25 1556 555	9 3170 7457
26 8600 3827	10 7868 5731
27 5072 1057	11 6121 10732
28 7928 3542	12 4843 9132
29 3226 3762	13 580 9591
0 7045 2420	14 6267 9290
1 9645 2641	15 3009 2268
2 2774 2452	16 195 2419
3 5331 2031	17 8016 1557
4 9400 7503	18 1516 9195
5 1850 2338	19 8062 9064
6 10456 9774	20 2095 8968
7 1692 9276	21 753 7326
8 10037 4038	22 6291 3833
9 3964 338	23 2614 7844
10 2640 5087	24 2303 646
11 858 3473	25 2075 611
12 5582 5683	26 4687 362
13 9523 916	27 8684 9940
14 4107 1559	28 4830 2065
15 4506 3491	29 7038 1363
16 8191 4182	0 1769 7837
17 10192 6157	1 3801 1689
18 5668 3305	2 10070 2359
19 3449 1540	3 3667 9918
20 4766 2697	4 1914 6920
21 4069 6675	5 4244 5669
22 1117 1016	6 10245 7821
23 5619 3085	7 7648 3944
24 8483 8400	8 3310 5488
25 8255 394	9 6346 9666
26 6338 5042	10 7088 6122
27 6174 5119	11 1291 7827
28 7203 1989	12 10592 8945
29 1781 5174	13 3609 7120
0 1464 3559	14 9168 9112
1 3376 4214	15 6203 8052
2 7238 67	16 3330 2895
3 10595 8831	17 4264 10563
4 1221 6513	18 10556 6496
5 5300 4652	19 8807 7645
6 1429 9749	20 1999 4530
7 7878 5131	21 9202 6818
8 4435 10284	22 3403 1734
9 6331 5507	23 2106 9023
10 6662 4941	24 6881 3883
11 9614 10238	25 3895 2171
12 8400 8025	26 4062 6424
13 9156 5630	27 3755 9536

28 4683 2131

29 7347 8027

Table B.10: Rate 8/9 ($n_{\text{ldpc}} = 64\ 800$)

0 6235 2848 3222	13 1969 3869	6 5821 4932	19 5736 1399	12 2644 5073
1 5800 3492 5348	14 3571 2420	7 6356 4756	0 970 2572	13 4212 5088
2 2757 927 90	15 4632 981	8 3930 418	1 2062 6599	14 3463 3889
3 6961 4516 4739	16 3215 4163	9 211 3094	2 4597 4870	15 5306 478
4 1172 3237 6264	17 973 3117	10 1007 4928	3 1228 6913	16 4320 6121
5 1927 2425 3683	18 3802 6198	11 3584 1235	4 4159 1037	17 3961 1125
6 3714 6309 2495	19 3794 3948	12 6982 2869	5 2916 2362	18 5699 1195
7 3070 6342 7154	0 3196 6126	13 1612 1013	6 395 1226	19 6511 792
8 2428 613 3761	1 573 1909	14 953 4964	7 6911 4548	0 3934 2778
9 2906 264 5927	2 850 4034	15 4555 4410	8 4618 2241	1 3238 6587
10 1716 1950 4273	3 5622 1601	16 4925 4842	9 4120 4280	2 1111 6596
11 4613 6179 3491	4 6005 524	17 5778 600	10 5825 474	3 1457 6226
12 4865 3286 6005	5 5251 5783	18 6509 2417	11 2154 5558	4 1446 3885
13 1343 5923 3529	6 172 2032	19 1260 4903	12 3793 5471	5 3907 4043
14 4589 4035 2132	7 1875 2475	0 3369 3031	13 5707 1595	6 6839 2873
15 1579 3920 6737	8 497 1291	1 3557 3224	14 1403 325	7 1733 5615
16 1644 1191 5998	9 2566 3430	2 3028 583	15 6601 5183	8 5202 4269
17 1482 2381 4620	10 1249 740	3 3258 440	16 6369 4569	9 3024 4722
18 6791 6014 6596	11 2944 1948	4 6226 6655	17 4846 896	10 5445 6372
19 2738 5918 3786	12 6528 2899	5 4895 1094	18 7092 6184	11 370 1828
0 5156 6166	13 2243 3616	6 1481 6847	19 6764 7127	12 4695 1600
1 1504 4356	14 867 3733	7 4433 1932	0 6358 1951	13 680 2074
2 130 1904	15 1374 4702	8 2107 1649	1 3117 6960	14 1801 6690
3 6027 3187	16 4698 2285	9 2119 2065	2 2710 7062	15 2669 1377
4 6718 759	17 4760 3917	10 4003 6388	3 1133 3604	16 2463 1681
5 6240 2870	18 1859 4058	11 6720 3622	4 3694 657	17 5972 5171
6 2343 1311	19 6141 3527	12 3694 4521	5 1355 110	18 5728 4284
7 1039 5465	0 2148 5066	13 1164 7050	6 3329 6736	19 1696 1459
8 6617 2513	1 1306 145	14 1965 3613	7 2505 3407	
9 1588 5222	2 2319 871	15 4331 66	8 2462 4806	
10 6561 535	3 3463 1061	16 2970 1796	9 4216 214	
11 4765 2054	4 5554 6647	17 4652 3218	10 5348 5619	
12 5966 6892	5 5837 339	18 1762 4777	11 6627 6243	

Table B.11: Rate 9/10 ($n_{\text{ldpc}} = 64\ 800$)

0 5611 2563 2900	17 3216 2178	16 6296 2583	15 1263 293	14 3267 649
1 5220 3143 4813	0 4165 884	17 1457 903	16 5949 4665	15 6236 593
2 2481 834 81	1 2896 3744	0 855 4475	17 4548 6380	16 646 2948
3 6265 4064 4265	2 874 2801	1 4097 3970	0 3171 4690	17 4213 1442
4 1055 2914 5638	3 3423 5579	2 4433 4361	1 5204 2114	0 5779 1596
5 1734 2182 3315	4 3404 3552	3 5198 541	2 6384 5565	1 2403 1237
6 3342 5678 2246	5 2876 5515	4 1146 4426	3 5722 1757	2 2217 1514
7 2185 552 3385	6 516 1719	5 3202 2902	4 2805 6264	3 5609 716
8 2615 236 5334	7 765 3631	6 2724 525	5 1202 2616	4 5155 3858
9 1546 1755 3846	8 5059 1441	7 1083 4124	6 1018 3244	5 1517 1312
10 4154 5561 3142	9 5629 598	8 2326 6003	7 4018 5289	6 2554 3158
11 4382 2957 5400	10 5405 473	9 5605 5990	8 2257 3067	7 5280 2643
12 1209 5329 3179	11 4724 5210	10 4376 1579	9 2483 3073	8 4990 1353
13 1421 3528 6063	12 155 1832	11 4407 984	10 1196 5329	9 5648 1170
14 1480 1072 5398	13 1689 2229	12 1332 6163	11 649 3918	10 1152 4366
15 3843 1777 4369	14 449 1164	13 5359 3975	12 3791 4581	11 3561 5368
16 1334 2145 4163	15 2308 3088	14 1907 1854	13 5028 3803	12 3581 1411
17 2368 5055 260	16 1122 669	15 3601 5748	14 3119 3506	13 5647 4661
0 6118 5405	17 2268 5758	16 6056 3266	15 4779 431	14 1542 5401
1 2994 4370	0 5878 2609	17 3322 4085	16 3888 5510	15 5078 2687
2 3405 1669	1 782 3359	0 1768 3244	17 4387 4084	16 316 1755
3 4640 5550	2 1231 4231	1 2149 144	0 5836 1692	17 3392 1991
4 1354 3921	3 4225 2052	2 1589 4291	1 5126 1078	
5 117 1713	4 4286 3517	3 5154 1252	2 5721 6165	
6 5425 2866	5 5531 3184	4 1855 5939	3 3540 2499	
7 6047 683	6 1935 4560	5 4820 2706	4 2225 6348	
8 5616 2582	7 1174 131	6 1475 3360	5 1044 1484	
9 2108 1179	8 3115 956	7 4266 693	6 6323 4042	
10 933 4921	9 3129 1088	8 4156 2018	7 1313 5603	
11 5953 2261	10 5238 4440	9 2103 752	8 1303 3496	
12 1430 4699	11 5722 4280	10 3710 3853	9 3516 3639	
13 5905 480	12 3540 375	11 5123 931	10 5161 2293	
14 4289 1846	13 191 2782	12 6146 3323	11 4682 3845	
15 5374 6208	14 906 4432	13 1939 5002	12 3045 643	
16 1775 3476	15 3225 1111	14 5140 1437	13 2818 2616	

Annex C (normative): Addresses of parity bit accumulators for $n_{ldpc} = 16\ 200$

Table C.1: Rate 1/4 ($n_{ldpc} = 16\ 200$)

6295 9626 304 7695 4839 4936 1660 144 11203 5567 6347 12557
 10691 4988 3859 3734 3071 3494 7687 10313 5964 8069 8296 11090
 10774 3613 5208 11177 7676 3549 8746 6583 7239 12265 2674 4292
 11869 3708 5981 8718 4908 10650 6805 3334 2627 10461 9285 11120
 7844 3079 10773
 3385 10854 5747
 1360 12010 12202
 6189 4241 2343
 9840 12726 4977

Table C.2: Rate 1/3 ($n_{ldpc} = 16\ 200$)

416 8909 4156 3216 3112 2560 2912 6405 8593 4969 6723 6912
 8978 3011 4339 9312 6396 2957 7288 5485 6031 10218 2226 3575
 3383 10059 1114 10008 10147 9384 4290 434 5139 3536 1965 2291
 2797 3693 7615 7077 743 1941 8716 6215 3840 5140 4582 5420
 6110 8551 1515 7404 4879 4946 5383 1831 3441 9569 10472 4306
 1505 5682 7778
 7172 6830 6623
 7281 3941 3505
 10270 8669 914
 3622 7563 9388
 9930 5058 4554
 4844 9609 2707
 6883 3237 1714
 4768 3878 10017
 10127 3334 8267

Table C.3: Rate 2/5 ($n_{ldpc} = 16\ 200$)

5650 4143 8750 583 6720 8071 635 1767 1344 6922 738 6658
 5696 1685 3207 415 7019 5023 5608 2605 857 6915 1770 8016
 3992 771 2190 7258 8970 7792 1802 1866 6137 8841 886 1931
 4108 3781 7577 6810 9322 8226 5396 5867 4428 8827 7766 2254
 4247 888 4367 8821 9660 324 5864 4774 227 7889 6405 8963
 9693 500 2520 2227 1811 9330 1928 5140 4030 4824 806 3134
 1652 8171 1435
 3366 6543 3745
 9286 8509 4645
 7397 5790 8972
 6597 4422 1799
 9276 4041 3847
 8683 7378 4946
 5348 1993 9186
 6724 9015 5646
 4502 4439 8474
 5107 7342 9442
 1387 8910 2660

Table C.4: Rate 1/2 ($n_{ldpc} = 16\ 200$)

20 712 2386 6354 4061 1062 5045 5158	11 8935 4996
21 2543 5748 4822 2348 3089 6328 5876	12 3028 764
22 926 5701 269 3693 2438 3190 3507	13 5988 1057
23 2802 4520 3577 5324 1091 4667 4449	14 7411 3450
24 5140 2003 1263 4742 6497 1185 6202	
0 4046 6934	
1 2855 66	
2 6694 212	
3 3439 1158	
4 3850 4422	
5 5924 290	
6 1467 4049	
7 7820 2242	
8 4606 3080	
9 4633 7877	
10 3884 6868	

Table C.5: Rate 3/5 ($n_{\text{ldpc}} = 16\ 200$)

2765 5713 6426 3596 1374 4811 2182 544 3394 2840 4310 771	5 1733 6028
4951 211 2208 723 1246 2928 398 5739 265 5601 5993 2615	6 3786 1936
210 4730 5777 3096 4282 6238 4939 1119 6463 5298 6320 4016	7 4292 956
4167 2063 4757 3157 5664 3956 6045 563 4284 2441 3412 6334	8 5692 3417
4201 2428 4474 59 1721 736 2997 428 3807 1513 4732 6195	9 266 4878
2670 3081 5139 3736 1999 5889 4362 3806 4534 5409 6384 5809	10 4913 3247
5516 1622 2906 3285 1257 5797 3816 817 875 2311 3543 1205	11 4763 3937
4244 2184 5415 1705 5642 4886 2333 287 1848 1121 3595 6022	12 3590 2903
2142 2830 4069 5654 1295 2951 3919 1356 884 1786 396 4738	13 2566 4215
0 2161 2653	14 5208 4707
1 1380 1461	15 3940 3388
2 2502 3707	16 5109 4556
3 3971 1057	17 4908 4177
4 5985 6062	

Table C.6: Rate 2/3 ($n_{\text{ldpc}} = 16\ 200$)

0 2084 1613 1548 1286 1460 3196 4297 2481 3369 3451 4620 2622	1 2583 1180
1 122 1516 3448 2880 1407 1847 3799 3529 373 971 4358 3108	2 1542 509
2 259 3399 929 2650 864 3996 3833 107 5287 164 3125 2350	3 4418 1005
3 342 3529	4 5212 5117
4 4198 2147	5 2155 2922
5 1880 4836	6 347 2696
6 3864 4910	7 226 4296
7 243 1542	8 1560 487
8 3011 1436	9 3926 1640
9 2167 2512	10 149 2928
10 4606 1003	11 2364 563
11 2835 705	12 635 688
12 3426 2365	13 231 1684
13 3848 2474	14 1129 3894
14 1360 1743	
0 163 2536	

Table C.7: Rate 3/4 ($n_{\text{ldpc}} = 16\ 200$)

3 3198 478 4207 1481 1009 2616 1924 3437 554 683 1801	8 1015 1945
4 2681 2135	9 1948 412
5 3107 4027	10 995 2238
6 2637 3373	11 4141 1907
7 3830 3449	0 2480 3079
8 4129 2060	1 3021 1088
9 4184 2742	2 713 1379
10 3946 1070	3 997 3903
11 2239 984	4 2323 3361
0 1458 3031	5 1110 986
1 3003 1328	6 2532 142
2 1137 1716	7 1690 2405
3 132 3725	8 1298 1881
4 1817 638	9 615 174
5 1774 3447	10 1648 3112
6 3632 1257	11 1415 2808
7 542 3694	

Table C.8: Rate 4/5 ($n_{\text{ldpc}} = 16\ 200$)

5 896 1565	7 951 2068	9 2116 1855
6 2493 184	8 3108 3542	0 722 1584
7 212 3210	9 307 1421	1 2767 1881
8 727 1339	0 2272 1197	2 2701 1610
9 3428 612	1 1800 3280	3 3283 1732
0 2663 1947	2 331 2308	4 168 1099
1 230 2695	3 465 2552	5 3074 243
2 2025 2794	4 1038 2479	6 3460 945
3 3039 283	5 1383 343	7 2049 1746
4 862 2889	6 94 236	8 566 1427
5 376 2110	7 2619 121	9 3545 1168
6 2034 2286	8 1497 2774	

Table C.9: Rate 5/6 ($n_{\text{ldpc}} = 16\ 200$)

3 2409 499 1481 908 559 716 1270 333 2508 2264 1702 2805	6 497 2228
4 2447 1926	7 2326 1579
5 414 1224	0 2482 256
6 2114 842	1 1117 1261
7 212 573	2 1257 1658
0 2383 2112	3 1478 1225
1 2286 2348	4 2511 980
2 545 819	5 2320 2675
3 1264 143	6 435 1278
4 1701 2258	7 228 503
5 964 166	0 1885 2369
6 114 2413	1 57 483
7 2243 81	2 838 1050
0 1245 1581	3 1231 1990
1 775 169	4 1738 68
2 1696 1104	5 2392 951
3 1914 2831	6 163 645
4 532 1450	7 2644 1704
5 91 974	

Table C.10: Rate 8/9 ($n_{\text{ldpc}} = 16\ 200$)

0 1558 712 805	4 1496 502	3 544 1190
1 1450 873 1337	0 1006 1701	4 1472 1246
2 1741 1129 1184	1 1155 97	0 508 630
3 294 806 1566	2 657 1403	1 421 1704
4 482 605 923	3 1453 624	2 284 898
0 926 1578	4 429 1495	3 392 577
1 777 1374	0 809 385	4 1155 556
2 608 151	1 367 151	0 631 1000
3 1195 210	2 1323 202	1 732 1368
4 1484 692	3 960 318	2 1328 329
0 427 488	4 1451 1039	3 1515 506
1 828 1124	0 1098 1722	4 1104 1172
2 874 1366	1 1015 1428	
3 1500 835	2 1261 1564	

Annex D (normative): Additional Mode Adaptation and ACM tools

D.1 "ACM Command" signalling interface

"ACM Command" signalling input (see figure D.1) shall allow setting, by an external "transmission mode control unit", of the transmission parameters to be adopted by the DVB-S2 modulator, for a specific portion of input data.

"ACM Command" shall carry the following information:

- MODCOD (5 bits, according to table 12).
- TYPE (2 bits, according to clause 5.5.2.3).
- CVALID (Command Valid).
- SEND (deliver Data).

The transmission format specified by MODCOD and TYPE shall be applied to user data received after CVALID = active and before SEND = active. When SEND = active, the modulator shall deliver user data immediately, even if a FECFRAME is not completed, by inserting the PADDING field (see clause 5.2.1). The user data included in the interval between CVALID = active and SEND = active shall not exceed the capacity of $(K_{\text{bch}}-80)$ bits, K_{bch} being the transmittable bits associated with a specific MODCOD and TYPE.

For input Transport Streams, ACM is implemented via null-packet deletion function, therefore input user data do not correspond directly to the transmitted data. In this case, the SEND function is not relevant, and CVALID, MODCOD and TYPE shall become active at least 10 times a second. The ACM modulator shall continuously apply the specified MODCOD and TYPE to user data after CVALID = active.

An example temporization of ACM Command is given in figure D.1, using a single serial interface to convey MODCOD, TYPE, CVALID(active = high-to-low transition) and SEND (active = low-to-high transition).

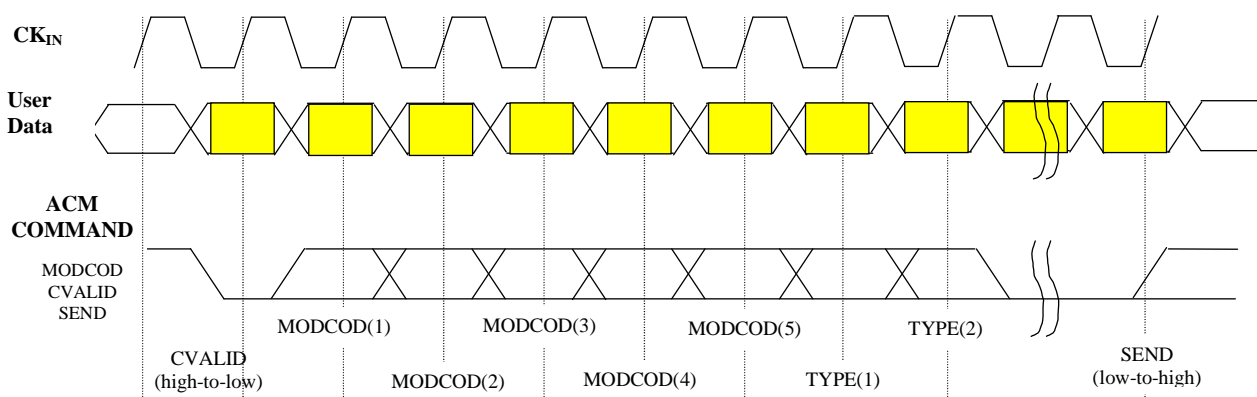

Figure D.1: Example temporization of ACM Command (serial format)

D.2 Input stream synchronizer

Delays and packet jitter introduced by DVB-S2 modems may depend from the transmitted bit-rate and may change in time during ACM rate switching. The "Input Stream Synchronizer" (see figures D.1 and D.2) shall provide a mechanism to regenerate, in the receiver, the clock of the Transport Stream (or Generic Packetized Stream) at the modulator Mode Adapter input, in order to guarantee end-to-end constant bit rates and delays (see also figure G.3, example receiver implementation). Table D.1 indicates the applications in which the Input Stream Synchronizer is normative or optional.

When $ISSYI = 1$ in MATYPE field (see table 3), a counter shall be activated (22 bits), clocked by the modulator symbol rate (frequency R_s). The Input Stream SYNchronization field (ISSY, 2 or 3 bytes) shall be appended after each input packet (in the case of Transport Streams, before null-packet deletion takes place), as shown in figure D.2. ISSY shall be coded according to table D.1, sending the following variables:

- ISCR (short: 15 bits; long: 22 bits) (ISCR = Input Stream Time Reference), loaded with the LSBs of the counter content at the instant the relevant input packet is processed (at constant rate R_{IN}), and specifically the instant the MSB of the relevant packet arrives at the modulator input stream interface.
- BUFS (2+10 bits) (BUFS = maximum size of the requested receiver buffer to compensate delay variations). It is assumed that a receiver FIFO buffer (see clause G.3, figure G.3) operates on a single stream input (i.e. corresponding to a specific MATYPE-2 configuration for SIS/MIS = 0 in MATYPE-1); the FIFO buffer input is the recovered packet stream after FEC error correction, at the channel arriving rate, and after null packet reinsertion, its output is the modulator output stream (to be sent to the TS demultiplexer in case of Transport Stream), read with the recovered (transport) stream clock. If $ISSYI = 1$ and optional BUFS is used, this variable shall be transmitted at least 5 times per second, replacing ISCR. The maximum buffer size required in the receiver shall be 20 Mbits.
- BUFSTAT (2+10 bits) (BUFSTAT = actual status to reset the receiver buffer = number of filled bits). If $ISSYI = 1$ and optional BUFSTAT is used, this variable shall be transmitted at least 5 times per second, replacing ISCR. This value can be used to set the receiver buffer status during reception start-up procedure, and to verify normal functioning in steady state.

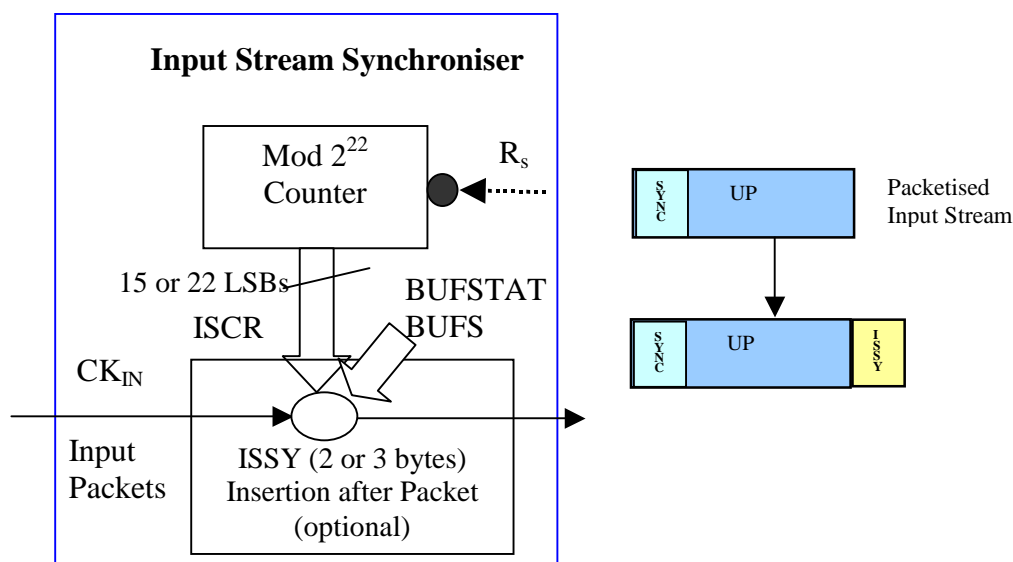

Figure D.2: Input stream synchronizer block diagram

Table D.1: ISSY field coding (2 or 3 bytes)

First Byte				Second Byte	Third Byte	
bit-7 (MSB)	bit-6	bit-5 and bit-4	bit-3 and bit-2	bit-7 to bit-0	bit-7 bit-0	
0 = ISCR _{short}	MSB of ISCR _{short}	next 6 bits of ISCR _{short}		next 8 bits of SCR _{short}	not present	
1	0 = ISCR _{long}	6 MSBs of ISCR _{long}		next 8 bits of ISCR _{long}	next 8 bits of ISCR _{long}	
1	1	00 = BUFS	BUFS unit 00 = bits 01 = Kbits 10 = Mbits 11 = reserved	2 MSBs of BUFS	next 8 bits of BUFS	not present when ISCR _{short} is used; else reserved
1	1	10 = BUFSTAT	BUFSTAT unit 00 = bits 01 = Kbits 10 = Mbits 11 = reserved	2 MSBs of BUFSTAT	next 8 bits of BUFSTAT	not present when ISCR _{short} is used; else reserved
1	1	others = reserved	reserved	reserved	reserved	not present when ISCR _{short} is used; else reserved

NOTE: For Generic Packetized Streams optional ISCR shall be limited to the "short" format.

An example receiver scheme to regenerate the output packet stream and the relevant clock R'_{IN} is given in figure G.3.

D.3 Null-packet Deletion (normative for input transport streams and ACM)

Transport Stream rules require that the bit rates at the output of the MUX and the input of the DEMUX are constant in time, and the end-to-end delay is also constant. In order to fulfil such requirements in an ACM environment, the null-packet deletion function shall be activated (see annex H.4 for application examples).

As shown in figure D.3, Useful Packets (i.e. packets with $PID \neq 8191_D$) (including the optional ISSY appended field) shall be transmitted while null-packets ($PID = 8191_D$) (including the optional ISSY appended field) shall be removed.

After transmission of a UP, a counter called DNP (Deleted Null-Packets, 1 byte) shall be first reset and then incremented at each deleted null-packet. The counter content shall be appended after the Least Significant Byte of the next transmitted useful packet, then DNP shall be reset. When DNP reaches the maximum allowed value $DNP = 255_D$, then if the following packet is again a null-packet this null-packet is kept as a useful packet and transmitted.

The resulting stream has $UPL = (188 + 1) \times 8$ bits (for $ISSYI = 0$) or $UPL = (188 + 2 + 1) \times 8$ bits (for $ISSYI = 1$ and $ISCR_{short}$), or $UPL = (188 + 3 + 1) \times 8$ bits (for $ISSYI = 1$ and $ISCR_{long}$), since the Transport Stream packets are extended by the DNP and ISSY (optional) fields.

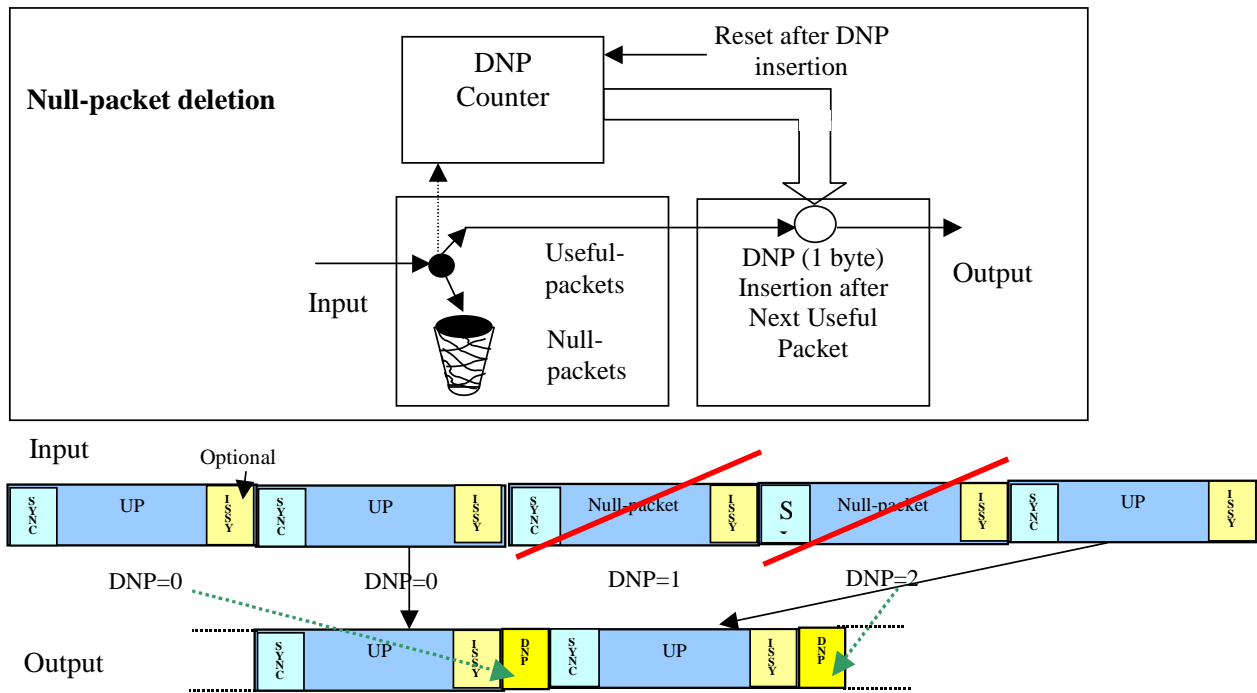

Figure D.3: Null-packet deletion and DNP field (1 byte) insertion

D.4 BBHEADER and Merging/slicing Policy for various application areas

According to the application area, BBHeader coding and Merging/slicing policy shall be according to table D.2.

Table D.2: BBHeader coding for various application areas and Merging/Slicing policy

Application area/configuration	MATYPE-1	MATYPE-2	UPL	DFL	SYNC	SYNCD	CRC-8	Merging/slicing policy
Broadcasting/CCM, single TS	111100Y	X	188 _D x8	K _{bch} - 80 _D	47 _{HEX}	Y	Y	Break No timeout No Padding No Dummy
Broadcasting, differentiated protection level per stream/VCM, constant protection level per TS, Multiple TS	1100Y0Y	Y	188 _D x8 (+16 or 24 if ISSYI = 1)	K _{bch} - 80 _D	47 _{HEX}	Y	Y	Break Read (1) No timeout No Padding Yes Dummy
DSNG with time variable protection level/ACM, single TS input, NP- deletion, ACM Command active	111011Y	X	189 _D x8+ (16 or 24)	K _{bch} - 80 _D	47 _{HEX}	Y	Y	Break Read (0) No timeout No Padding Yes Dummy
Interactive services with ACM over TS, differentiated protection per stream/ ACM, constant protection level per TS, Multiple TS, NP- deletion	1100Y1Y	Y	189 _D x8 (+16 or 24 if ISSYI = 1)	Y ≤ K _{bch} - 80 _D	47 _{HEX}	Y	Y	Read(1) or (2) Yes Padding Yes Dummy YES shortframe (see note)
Interactive services (IP) with ACM over GS, differentiated protection per stream/ ACM, constant protection level per input stream, Multiple Generic Stream	010000Y	Y	0	Y ≤ K _{bch} - 80 _D	X	X	Y	Read(1) or (2) Yes Padding Yes Dummy YES shortframe (see note)
Interactive services (IP) with ACM over GS, time variable protection/ ACM, time variable protection level, Single Generic Stream, ACM Command active	011000Y	X	0	Y ≤ K _{bch} - 80 _D	X	X	Y	According to ACM Command Yes Padding Yes Dummy YES shortframe
BC Broadcasting services	111100Y	X	188 _D x8	K _{bch} - 80 _D	47 _{HEX}	Y	Y	Break No timeout No Padding No Dummy

X = not defined; Y = according to configuration/computation Break = break packets in subsequent DATAFIELDS;
Timeout: maximum delay in merger/slicer buffer.
Read (0) = Read [K_{bch} (Normal FECFRAME) - 80] bits when available, otherwise dummy.
Read (1) = Round-robin polling. Read [K_{bch} (Normal FECFRAME) - 80] bits from port i when available, otherwise poll the next port.
Read (2) = On timeout, read DFL bits from port i and select the shortest FECFRAME containing DFL.
NOTE: Additional merging policy modes may be optionally implemented by manufacturers.

D.5 Signalling of reception quality via return channel (Normative for ACM)

In ACM modes, the receiver shall signal the reception quality via an available return channel, according to the various DVB interactive systems, such as for example DVB-RCS (EN 301 790 [6]), DVB-RCP (ETS 300 801 [7]), DVB-RCG (EN 301 195 [8]), DVB-RCC (ES 200 800 [9]).

DVB "Network Independent Protocols for DVB Interactive Services" (ETS 300 802 [11]) may be adopted to achieve maximum network interoperability. Other simpler or optimized solutions (e.g. to guarantee minimum signalling delay) may be adopted to directly interface with the aforementioned DVB interactive systems.

The receiver shall evaluate quality-of-reception parameters, in particular carrier to noise plus interference ratio in dB available at the receiver, indicated as **CNI**. CNI format shall be:

$$\text{CNI} = 20 + 10 \{ 10 \text{Log}_{10}[\text{C} / (\text{N} + \text{I})] \} \text{ (positive integer, 8 bits, in the range 0 to 255).}$$

In fact for DVB-S2 $10 \text{Log}_{10}[\text{C} / (\text{N} + \text{I})]$ may be in the range -2 dB to +23,5 dB.

$10 \text{Log}_{10}[\text{C} / (\text{N} + \text{I})]$ shall be evaluated with a quantized accuracy better than 1 dB (accuracy = mean error + 3 σ , where σ is the standard deviation). Since modulation and coding modes for DVB-S2 are typically spaced 1 dB to 1,5 dB apart, a quantized precision better than 0,3 dB is recommended in order to fully exploit system capabilities. The measurement process is assumed to be continuous. A possible method to evaluate CNI is by using symbols known a-priori at the receiver, such as those in the SOF field of the PLFRAME Header and, when available, pilot symbols.

CNI and other optional reception quality parameters (such as for example the BER on the channel evaluated by counting the errors corrected by the LDPC decoder, the packet error rate detected by CRC-8, the CNI distance from the QEF threshold) may optionally be used by the receiver to identify the maximum throughput DVB-S2 transmission mode that it may decode at QEF, indicated by MODCOD_RQ (7 bits, b_6, \dots, b_0) where:

- (b_4, \dots, b_0) are coded according to MODCOD in table 12;
- b_5 indicates the presence/absence of pilots: ($b_5 = 0$ no pilots, $b_5 = 1$ pilots);
- $b_6 = 1$ indicates (b_5, \dots, b_0) are valid; $b_6 = 0$ indicates (b_5, \dots, b_0) information is not available by the terminal.

As a minimum, the CNI and MODCOD_RQ parameters shall be sent to the satellite network operator Gateway every time the protection on the DVB-S2 channel has to be changed. When no modification of the protection level is requested, the optional message from the terminal to the Gateway shall indicate MODCOD_RQ = actual MODCOD and pilot configuration of the frames received by the terminal. In specific applications, CNI and MODCOD_RQ fields may be extended to an integer number of byte(s), by padding zeroes in MSB positions.

The maximum delay required for CNI and MODCOD evaluation and delivery to the Gateway via the interaction channel shall be no more than 300 ms, but this delay should be minimized if services interruptions are to be avoided under fast fading conditions (C/N+I variations as fast as 0,5 dB/s to 1 dB/s may occur in Ka band). Optionally the gateway may acknowledge the reception of the message and the execution of the command by a message containing the new adopted MODCOD, coded according to table 12. The allocated protection shall be equal or more robust than that requested by the terminal.

Example Transmission Protocol using [11]

DVBS2_Change_Modcod message shall be sent from the receiving terminal to the satellite network operator gateway, every time the protection on the DVB-S2 channel has to be changed.

```
DVBS2_Change_Modcod()  length in bits (big-endian notation)
{
  CNI;                 8
  MODCOD_RQ;          8
}
```

DVBS2_Ack_Modcod message shall optionally be sent from the Gateway to the receiving terminal to acknowledge the DVB-S2 protection level modification. MODCOD_ACK shall be coded according to the MODCOD_RQ conventions.

```
DVBS2_Ack_Modcod()  length in bits (big-endian notation)
{
  MODCOD_ACK;        8
}
```

Annex E (normative): SI and signal identification for DSNG and contribution applications

In DSNG transmissions, editing of the SI tables in the field may be impossible due to operational problems. Therefore, only the following MPEG.2-defined SI tables PAT, PMT and Transport Stream Descriptor Table (TSDT) are mandatory. DSNG transmission using DVB-S2 shall implement SI according to annex D of EN 301 210 [3].

Satellite transmissions may be affected by interference problems, which may be generated by SNG stations not strictly adhering to standard operating regulations. Although solutions to this problem are mostly based on operational rules, DVB-S2 provides technical means to allow interfering station identification. DVB-S2 up-link stations (except stations for broadcast services) shall make their signal identifiable by applying the Physical Layer Scrambling initialization sequence n (n in the range 0 to 262 141; see clause 5.5.4) assigned to each station owner.

Annex F (normative): Backwards Compatible modes (optional)

Optional Backwards Compatible (BC) modes are intended to send, on a single satellite channel, two Transport Streams, the first (High Priority, HP) being compatible with DVB-S receivers (according to EN 300 421 [2]) as well as with DVB-S2 receivers, the second (Low Priority, LP) being compatible with DVB-S2 receivers only. Backwards compatibility can be optionally implemented according to two approaches:

- layered modulations, where a DVB-S2 and a DVB-S signals are asynchronously combined on the radio-frequency channel (therefore this operational mode does not require any specific tool in the DVB-S2 specification).
- hierarchical modulation, where the two HP and LP Transport Streams are synchronously combined at modulation symbol level on an asymmetric 8PSK constellation.

NOTE 1: Hierarchical modes are also used in EN 300 744 [i.2].

NOTE 2: Also other non-DVB legacy broadcast services based on QPSK may transmit a DVB-S2 LP stream, using the aforementioned hierarchical and layered modulation schemes.

Figure F.1 schematically represents the hierarchical transmission system structure: it consists of two branches, the first compliant with DVB-S standard for the high priority layer, the second increasing the constellation dimensionality to a non-uniform 8PSK for the low priority layer.

Figure F.2 shows the non-uniform 8PSK transmitted constellation.

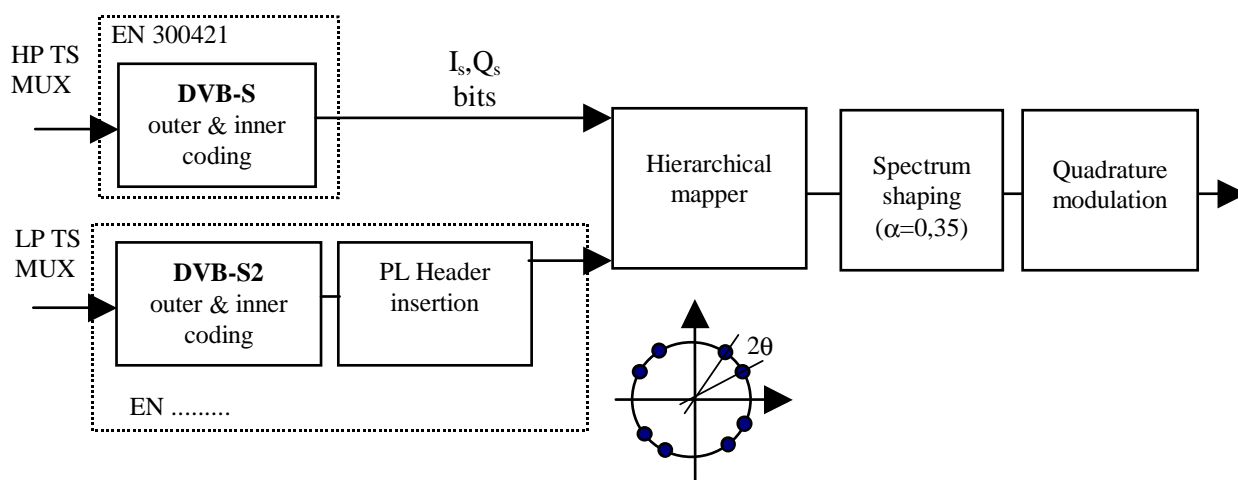

Figure F.1: Functional block diagram of hierarchical backward compatible DVB-S2 system

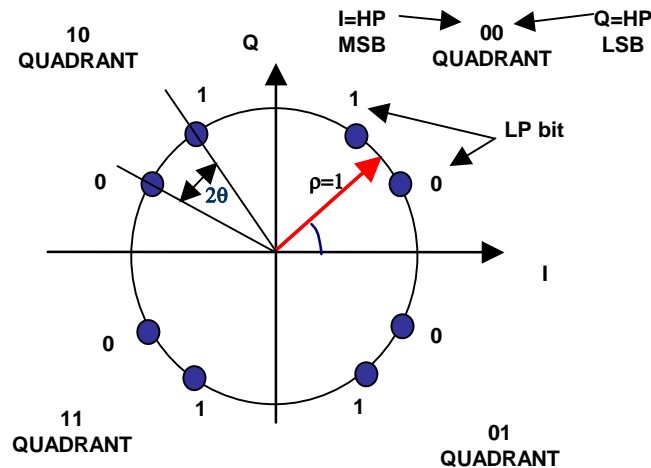

Figure F.2: Non-uniform 8PSK constellation

For hierarchical modulation, the LP DVB-S2 compliant signal shall be BCH and LDPC encoded, with LDPC code rates 1/4, 1/3, 1/2 or 3/5. The LP stream shall be generated by the DVB-S2 system according to figure 1. The hierarchical mapper shall map three bits per symbol as in the figure F.2:

- one bit from the DVB-S2 LDPC encoded signal, following PLHEADER insertion; two bits from the HP DVB-S encoder.

The deviation angle θ may vary according to user requirements.

NOTE: θ may be constrained by legacy receiver performance, such as carrier recovery cycle slips: large θ figures improve LP ruggedness against noise and interference, but penalize HP. clause H.6 gives examples of the HP and LP performance versus θ .

The PLHEADER sequence shall comprise 90 bits to indicate the LP code rate being transmitted, as follow, shown octal encoded, MSB (leftmost bit) transmitted first:

- 441647550603300214057262124712 indicates 1/4 rate;
- 753012530643221406326217103300 indicates 1/3 rate;
- 247124232750142006603055713411 indicates 1/2 rate;
- 006604742326301422613065240657 indicates 3/5 rate.

Dummy Frames and short frames shall not be used for BC modes.

Table F.1 gives the number of SLOTS per FECFRAME in the LP stream. Table F.2 gives the bit-rate ratio (%) of the LP stream versus the HP stream.

Table F.1: S = number of SLOTS (M = 90 symbols) per FECFRAME

$n_{ldpc} = 64\ 800$ (normal frame)	
η_{MOD} (bit/s/Hz) for LP stream	S
1	720

Table F.2: (LP bit-rate/HP bit-rate)x100 [%]

DVB-S Coding (HP)	DVB-S2 Coding (LP)			
	1/4	1/3	1/2	3/5
1/2	26,6	35,7	53,7	64,6
2/3	20,0	26,7	40,3	48,4
3/4	17,8	23,8	35,8	43,0
5/6	16,0	21,4	32,2	38,7
7/8	15,2	20,4	30,7	36,9

Annex G (informative): Supplementary information on receiver implementation

Receiver specification is not under the scope of the present document. Nevertheless the DVB-S2 specification has been developed devoting a large effort to technical evaluations on the receiver design, in order to guarantee that the end-to-end performance target may be met. Typical impairments that may significantly impact the performance of the receiver are:

- phase noise of the LNB and tuner;
- quality of the transmitter and/or receiver oscillators;
- adjacent channel interference;
- satellite non-linearity.

This clause includes some tutorial material on receiver implementation, although other techniques may be used offering the target functionalities and receiver performance.

G.1 Carrier recovery

A significant portion of DVB-S2 deployment will replace/enhance the current DVB-S users. In this situation, it is highly desirable that the outdoor equipment including the LNB will be retained. Extensive simulation studies have been carried out, using the critical phase noise model of consumer LNB from annex H.8, and implementing variants of three baseline carrier recovery techniques:

- decision directed digital phase locked loops with "blind" phase error detection (DD-PLL), operating on the modulated symbols;
- pilot-symbol aided DD-PLL (phase estimations extracted from the pilot symbols and from the PLHEADER are used to reset the DD-PLL circuit, which otherwise operates on the modulated symbols);
- pilot-symbol interpolation techniques (phase estimations extracted from the pilot symbols are interpolated over the modulated symbols).

With the receiver algorithms taken into consideration, the simulation results demonstrate that carrier synchronization can be achieved in presence of phase noise and worst-case thermal noise for any DVB-S2 mode. Some of the transmission modes, such as for example 8PSK rate 3/5 and rate 2/3, 16APSK rate 3/4, 32APSK 4/5 required the use of pilot symbols to avoid cycle slips. For ACM operation, the use of pilot symbols can guarantee continuous receiver synchronization.

G.2 FEC decoding

LDPC codes are linear block codes with sparse parity check matrices $H_{(n-k) \times n}$.

As an example, an LDPC code of length $N = 8$ and rate $1/2$ can be specified by the following parity check matrix.

$$H = \begin{matrix} & \begin{matrix} n_1 & n_2 & n_3 & n_4 & n_5 & n_6 & n_7 & n_8 \end{matrix} \\ \begin{matrix} \left[\begin{array}{cccccccc} 1 & 0 & 0 & 1 & 1 & 0 & 0 & 1 \\ 0 & 1 & 1 & 0 & 1 & 0 & 1 & 0 \\ 1 & 0 & 1 & 0 & 0 & 1 & 0 & 1 \\ 0 & 1 & 0 & 1 & 0 & 1 & 1 & 0 \end{array} \right] \end{matrix} & \begin{matrix} m_1 \\ m_2 \\ m_3 \\ m_4 \end{matrix} \end{matrix}$$

The same code can be equivalently represented by the bipartite graph in figure G.1(a) which connects each check equation (check node) to its participating bits (bit nodes).

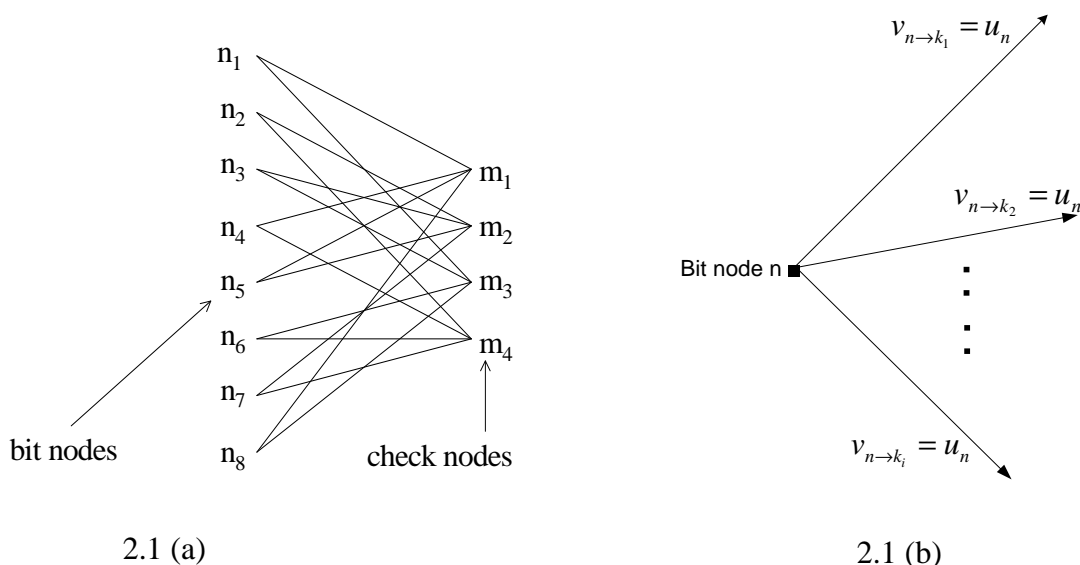

**Figure G.1: (a) Bipartite graph of an LDPC code;
(b) Initialization of outgoing messages from bit nodes**

The purpose of the decoder is to determine the transmitted values of the bits. Bit nodes and check nodes communicate with each other to accomplish that. The decoding starts by assigning the channel values to the outgoing edges from bit nodes to check nodes. Upon receiving that, the check nodes make use of the parity check equations to update the bit node information and send it back. Each bit node then performs a soft majority vote among the information reaching him. At this point, if the hard decisions on the bits satisfy all of the parity check equations, it means a valid codeword has been found and the process stops. Otherwise bit nodes go on sending the result of their soft majority votes to the check nodes. In the following clauses, we describe the decoding algorithm in detail. The number of edges adjacent to a node is called the degree of that node.

- Initialization:

$$v_{n \rightarrow k_i} = u_n, \quad n = 0, 1, \dots, N-1, \quad i = 1, 2, \dots, \text{deg}(\text{bit node } n)$$

Here $v_{n \rightarrow k_i}$ denotes the message that goes from bit node n to its adjacent check node k_i , u_n denotes the channel value for the bit n and N is the codeword size. The initialization process is also shown in figure G.1(b).

- Check node update:

Let us denote the incoming messages to the check node k from its d_c adjacent bit nodes by

$v_{n_1 \rightarrow k}, v_{n_2 \rightarrow k}, \dots, v_{n_{d_c} \rightarrow k}$ (see figure G.2(a)). Our aim is to compute the outgoing messages from the check node k back to d_c adjacent bit nodes. Let us denote these messages by $w_{k \rightarrow n_1}, w_{k \rightarrow n_2}, \dots, w_{k \rightarrow n_{d_c}}$.

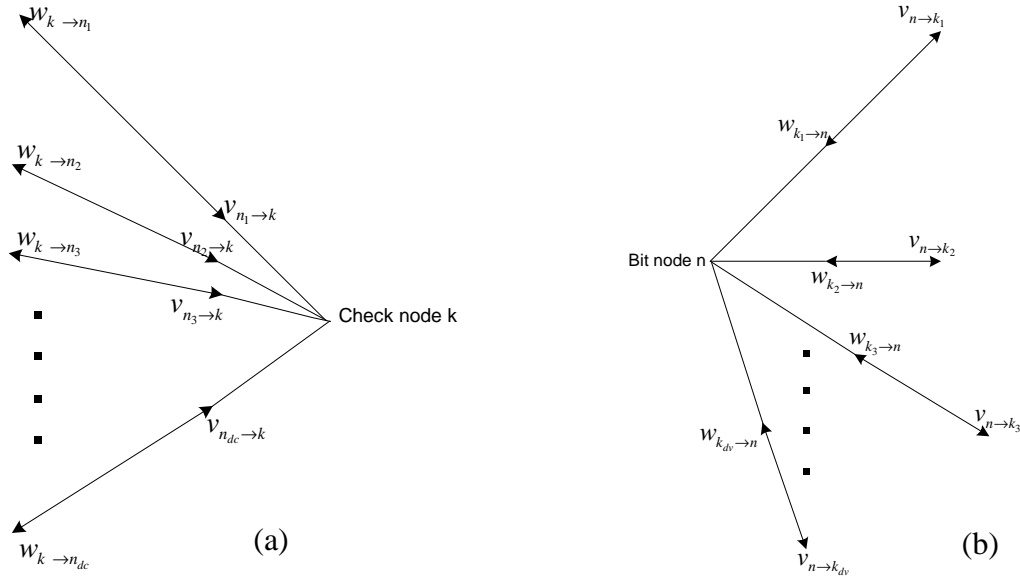

Figure G.2: Message update at check nodes (a), and at bit nodes (b)

$$w_{k \rightarrow n_i} = g(v_{n_1 \rightarrow k}, v_{n_2 \rightarrow k}, \dots, v_{n_{i-1} \rightarrow k}, v_{n_{i+1} \rightarrow k}, \dots, v_{n_{dc} \rightarrow k})$$

where $g(a, b) = \text{sign}(a) \times \text{sign}(b) \times \{\min(|a|, |b|)\} + LUT_g(a, b)$;

and $LUT_g(a, b) = \log(1 + e^{-|a+b|}) - \log(1 + e^{-|a-b|})$.

- Bit Node Update:

Let us denote the incoming messages to the bit node n from its d_v adjacent check nodes by $w_{k_1 \rightarrow n}, w_{k_2 \rightarrow n}, \dots, w_{k_{dv} \rightarrow n}$ (see figure G.2(b)). Our aim is to compute the outgoing messages from the bit node n back to d_v adjacent check nodes. Let us denote these messages by $v_{n \rightarrow k_1}, v_{n \rightarrow k_2}, \dots, v_{n \rightarrow k_{dv}}$.

They are computed as follows: $v_{n \rightarrow k_i} = u_n + \sum_{j \neq i} w_{k_j \rightarrow n}$.

- Hard Decision Making:

After the bit node updates, hard decision can be made for each bit n by looking at the sign of $v_{n \rightarrow k_i} + w_{k_i \rightarrow n}$ for any k_i . If the hard decisions satisfy all the parity check equations, it means a valid codeword has been found, therefore the process stops. Otherwise another check node/bit node update is performed. If no convergence is achieved after a pre-determined number of iterations, the current output is given out. As SNR increases, the decoder converges with fewer iterations.

G.3 ACM: Transport Stream regeneration and clock recovery using ISCR

When the modulator operates in ACM mode (null-packet deletion active), the receiver may regenerate the Transport Stream by inserting, before each useful packet, DNP in the reception FIFO buffer. As shown in figure G.3, the Transport Stream clock R'_{IN} may be recovered by means of a Phase Locked Loop (PLL). The recovered symbol-rate R_s may be used to clock a local counter (which by definition runs synchronously with the input stream synchronization counter of figure D.2, apart from the Satellite Doppler frequency shift). The PLL compares the local counter content with the transmitted ISCR of each TS packet, and the phase difference may be used to adjust the R'_{IN} clock. In this way R'_{IN} remains constant, and the reception FIFO buffer automatically compensates the chain delay variations. Since the reception FIFO buffer is not self-balancing, the BUFSTAT and the BUFS information may be used to set its initial state.

As an alternative, when dynamic variations of the end-to-end delay and bit-rate may be acceptable by the source decoders, the receiver buffer filling condition may be used to drive the PLL. In this case the reception buffer is self-balancing (in steady state half of cells are filled), and the ISSY field may be omitted at the transmitting side.

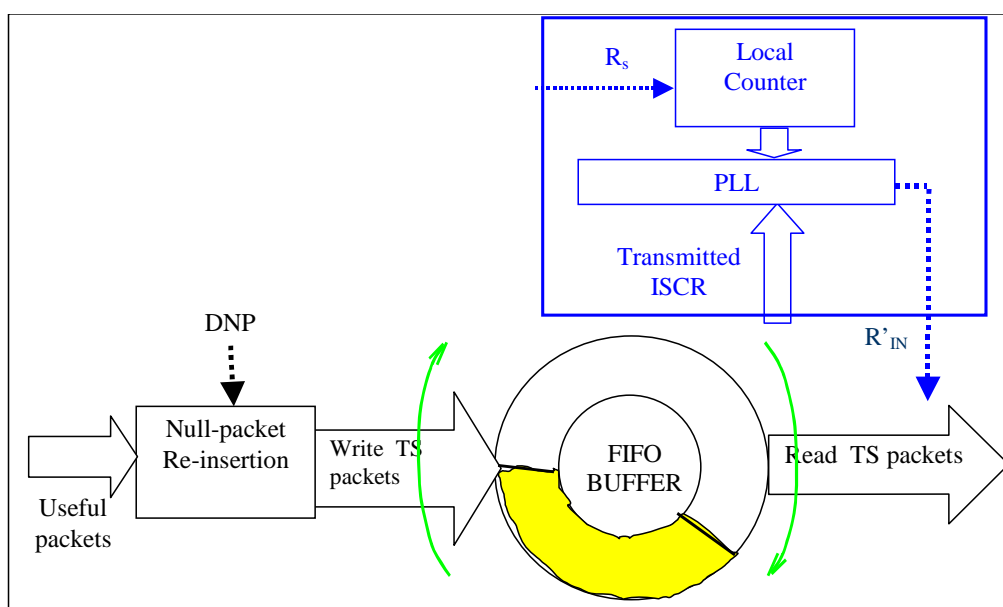

Figure G.3: Example receiver block diagram for Null-packet re-insertion and R_{TS} clock recovery

G.4 Non linearity pre-compensation and Intersymbol Interference suppression techniques

A significant feature of DVB-S2 standard is to support high-order modulation such as 16 APSK and 32 APSK. These modulation schemes, although specifically designed for non-linear channels, are particularly sensitive to the characteristics of the satellite transponders. Computer simulation studies, based on the use of the satellite transponder model of clause H.7, demonstrated that there are significant opportunities to further enhance the performance by pre-distortion of the transmitted signal and/or intersymbol interference suppression technique in the receiver.

G.5 Interactive services using DVB-RCS return link: user terminal synchronization

Interactive services can be operated with a DVB-RCS (EN 301 790 [6]) return path, provided that an absolute time reference (NCR, Network Clock Reference) can be generated in the user terminal for transmissions alignment. In DVB-RCS the hub broadcasts the NCR in the form of special transport packets over the forward link. In case of DVB-S2 forward link, NCR shall be associated to the emission time, at the transmitting side, of the first symbol of the SOF field.

In order to facilitate RCS synchronization at user terminal, a "SOF flag" output should be included in the DVB-S2 receiver chipset. Furthermore, in order to allow alignment of the SOF flag with the relevant NCR, the receiver chipset should implement an internal counter of the received physical layer frames (e.g. modulo $M = 32$), with arbitrary start-up. The counter content should label both the "SOF flag" and the decoded data at the chip output. In practical implementations the SOF flag label could be signalled serially on the SOF flag signal and the frame label on another signal.

Annex H (informative): Examples of possible use of the System

H.1 CCM digital TV broadcasting: bit rate capacity and C/N requirements

The DVB-S2 system may be used in "single carrier per transponder" or in "multi-carriers per transponder" (FDM) configurations. In single carrier per transponder configurations, the transmission symbol rate R_S can be matched to given transponder bandwidth BW (at -3 dB), to achieve the maximum transmission capacity compatible with the acceptable signal degradation due to transponder bandwidth limitations. To take into account possible thermal and ageing instabilities, reference can be made to the frequency response mask of the transponder. Group delay equalization at the transmitter may be used to increase the transmission capacity or to reduce degradation.

In the multi-carrier FDM configuration, R_S can be matched to the frequency slot BS allocated to the service by the frequency plan, to optimize the transmission capacity while keeping the mutual interference between adjacent carriers at an acceptable level.

Figure H.1 gives examples of the useful bit rate capacity R_u achievable by the System versus the LDPC code rate, assuming unit symbol rate R_S . The symbol rate R_S corresponds to the -3 dB bandwidth of the modulated signal. $R_S (1+\alpha)$ corresponds to the theoretical total signal bandwidth after the modulator. The figures refer to Constant Coding and Modulation, normal FECFRAME length (64 800 bit), no PADDING field, no pilots (the pilots would reduce the efficiency by about 2,4 %). Typical BW/ R_S or BS/ R_S ratios are $1 + \alpha = 1,35$ and $1,20$, where α is the roll-off factor of the modulation. This choice allows to obtain a negligible E_S/N_0 degradation due to transponder bandwidth limitations, and also to adjacent channel interference on a linear channel. BW/ R_S factors $< 1 + \alpha$ may also be adopted, but careful studies should be carried-out on a case-by-case basis to avoid unacceptable interference and distortion levels.

Figure H.2 shows the required C/N (Carrier-to-Noise power ratio measured in a bandwidth equal to the symbol rate) versus the spectrum efficiency (useful bit-rate for unit symbol rate R_S), obtained by computer simulations on the AWGN channel (ideal demodulator, no phase noise). The performance of DVB-S and DVB-DSNG is also shown for comparison, for the same quality target $PER = 10^{-7}$. Before Nyquist filtering in the modulator, the peak-to-average power ratio is 0 dB for QPSK and 8PSK, while it is in the range [1,05 ÷ 1,11] dB for 16APSK (the exact value can be calculated using expression $4 \gamma^2 / (3 \gamma^2 + 1)$) and [1,97 ÷ 2,12] dB for 32APSK (the exact expression is $8 \gamma_2^2 / (4 \gamma_2^2 + 3 \gamma_1^2 + 1)$). When DVB-S2 is transmitted by satellite, quasi-constant envelope modulations, such as QPSK and 8PSK, are power efficient in single carrier per transponder configuration, since they can operate on transponders driven near saturation. 16APSK and 32APSK, which are inherently more sensitive to non-linear distortions and would require quasi-linear transponders (i.e. with larger Output-Back-Off, OBO) may be improved in terms of power efficiency by using non-linear compensation techniques in the up-link station.

The use of the narrower roll-off $\alpha = 0,25$ and $\alpha = 0,20$ may allow a transmission capacity increase but may also produce larger non-linear degradations by satellite for single carrier operation.

In the FDM configuration, the satellite transponder should be quasi-linear (i.e. with large Output-Back-Off, OBO) to avoid excessive intermodulation interference between signals.

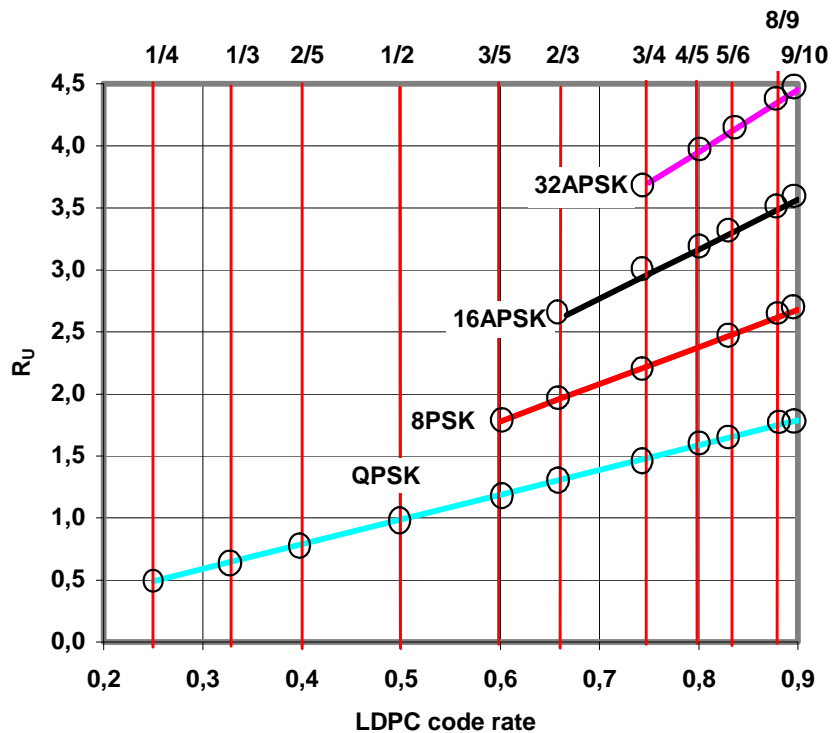

Figure H.1: Examples of useful bit rates R_u versus LDPC code rate per unit symbol rate R_s

Spectrum efficiency versus required C/N on AWGN channel

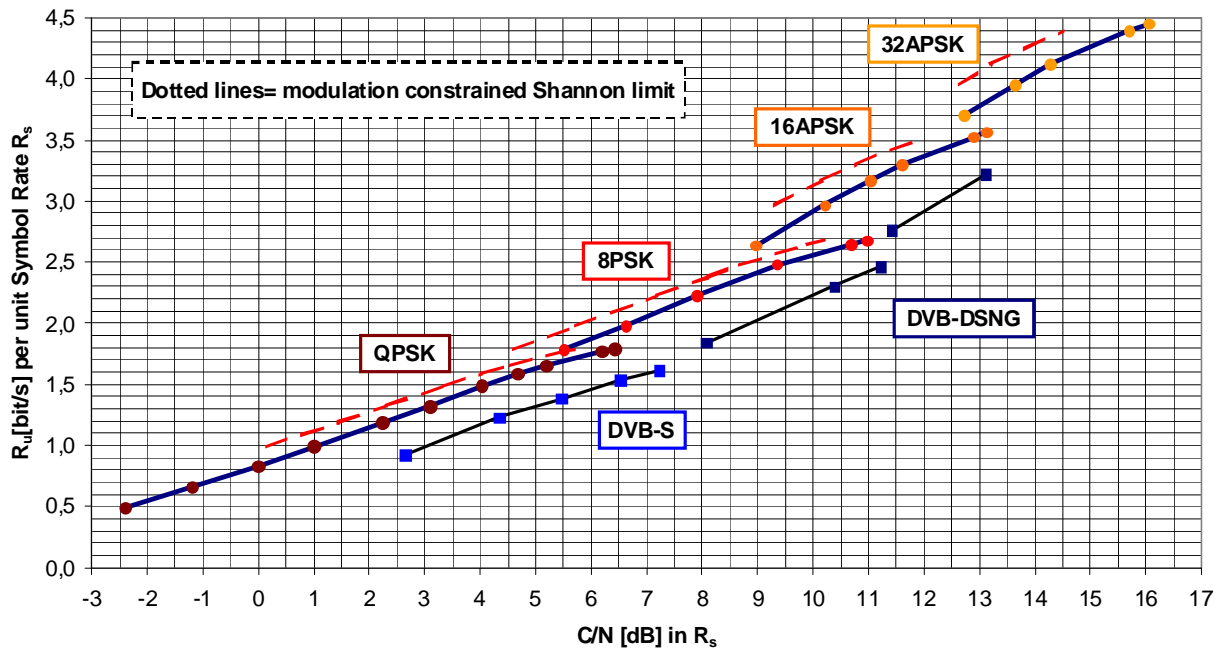

Figure H.2: Required C/N versus spectrum efficiency, obtained by computer simulations on the AWGN channel (ideal demodulator) (C/N refers to average power)

Table H.1 shows the C/N degradation measured by computer simulations using the satellite channel models given in annexes H.7 (non linearized TWTA) and H.8. The following parameters have been simulated: $R_S = 27,5$ Mbaud, roll-off = 30 % (not available in DVB-S2, but giving performance between roll-off 0,35 and 0,25), dynamic pre-distortion memory $M = 5$ (for QPSK, 8PSK and 16APSK), $M = 3$ (for 32APSK). C_{SAT} is the un-modulated carrier power at HPA saturation, OBO is the measured power ratio (dB) between the un-modulated carrier at saturation and the modulated carrier (after OMUX). The considered phase noise mask is relevant to a low-cost consumer LNB, while for professional applications lower degradations may be expected.

Table H.1: C/N degradation [dB] on the satellite channel (simulation results)

Transmission Mode	C_{SAT}/N loss [dB] no predistortion without Phase Noise	C_{SAT}/N loss [dB] with dynamic predistortion without Phase Noise	C_{SAT}/N loss [dB] with dynamic predistortion with Phase Noise
QPSK 1/2	0,62 (IBO = 0; OBO = 0,33)	0,5 (IBO = 0 dB; OBO = 0,38)	0,63
8PSK 2/3	0,95 (IBO = 0,5; OBO = 0,35)	0,6 (IBO = 0; OBO = 0,42)	0,85
16APSK 3/4	3,2 (IBO = 5; OBO = 1,7)	1,5 (IBO = 1; OBO = 1,1)	1,8
32APSK 4/5	6,2 (IBO = 9; OBO = 3,7)	2,8 (IBO = 3,6; OBO = 2,0)	3,5

H.2 Distribution of multiple TS multiplexes to DTT Transmitters (Multiple TS, CCM)

The DVB-S2 system is suitable for the distribution of N MPEG multiplexes to digital terrestrial transmitters, using a single carrier per transponder configuration, thus optimizing the power efficiency by saturating the satellite HPA (with the DVB-S system N carriers per transponder should be transmitted, requiring a large HPA OBO). For example, assuming the availability of a $BW = 36$ MHz transponder, a symbol rate of 30 Mbaud may be transmitted using $\alpha = 0,20$. Thus to transmit two DTT MUXes at 24 Mbit/s each, a spectrum efficiency of 1,6 [bit/s/Hz] is required, corresponding to QPSK rate 5/6 (required C/N = 5,2+0,7 dB + implementation margin). Figure H.3 shows an example of possible configuration at the transmitting side.

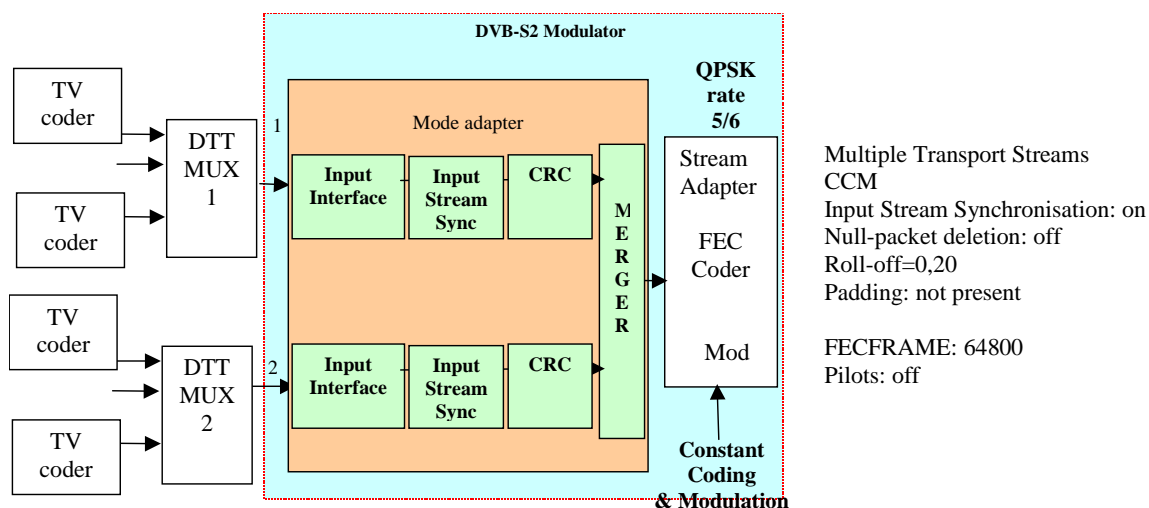

Figure H.3: Example of DVB-S2 configuration for multiple DTT multiplexes distribution by satellite

- 2) The TS bit-rate is set at the maximum level receivable at QeF in clear sky. The TS multiplexer adds null-packets to generate the constant bit-rate R_{TS} .
- 3) Null Packets (NP) are deleted in the Mode Adapter, so that the actual bit-rate on the channel corresponds to the source bit-rate. The deleted NPs are signalled in the DNP byte.
- 4) The receiver re-inserts Null Packets exactly in the original position (by decoding DNP), and the Transport Stream clock is regenerated using the Input Stream Clock Reference (ISCR).

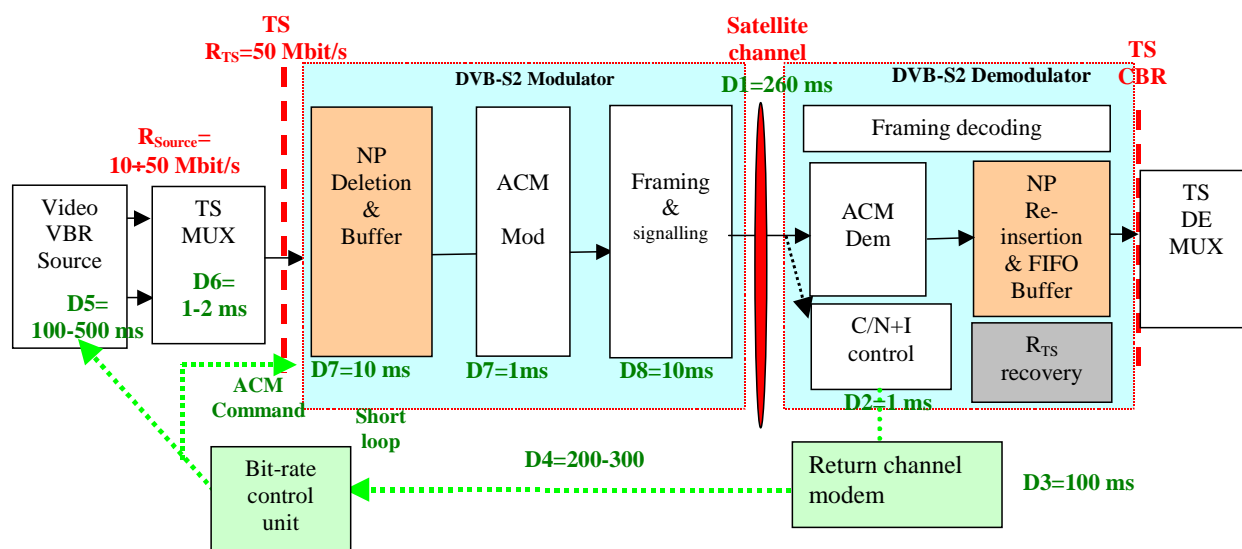

Figure H.6: Single TS - uniform protection for long periods: transmission and receiving schemes

With reference to figure H.6, during a fast fading the bit rate control unit may impose a rate reduction first on the source encoder, and only after the command has been executed (e.g. after 100 ms to 500 ms), to the DVB-S2 modulator (via ACM Command). A drawback of this configuration is that the video encoder and MUX delays (D_5 and D_6 in figure H.6) are included in the control loop, with the risk of service outage under fast fading conditions. To overcome this additional delay the ACM Command can be instantly delivered also to the modulator, but to avoid packet losses large buffers have to be inserted in the DVB-S2 modulator and demodulator.

H.5 IP Unicast Services (Non-uniform protection on a user-by-user basis)

Figure H.7 shows a possible exchange of information (info request and info response) between the user, the Satellite Gateway and the information provider during an Internet navigation session by satellite (forward high capacity link).

These interactive data services may take advantage of:

- non-uniform error protection (ACM);
- differentiated service levels (priority in the delivery queues).

According to the negotiation between the user terminal and the "ACM routing manager", an "ACM router" may in principle separate IP packets per user, per required error protection and per service level. The aggregate input traffic on the various protection levels should not overload the available channel capacity; this applies to the average input traffic, while the peak traffic may temporarily exceed it, compatibly with the input buffering capacity and the service requirements on maximum delays.

To fulfil this rule, when the total offered traffic becomes larger than the channel capacity, lower priority IP packets may be delayed (or even dropped) in favour of high priority packets. If the control-loop delays (including routing manager and ACM router) are too large to allow error free reception under fast-fading conditions, real time services (e.g. video/audio streaming) may be permanently allocated to a high protection branch, while lower priority services (e.g. best effort) may exploit the higher efficiency (i.e. lower cost) provided by ACM. It should be noted that the polling strategy of the input buffers may be statically or dynamically profiled according to the traffic statistics, the propagation characteristics, and the traffic prioritization policy of the service operator.

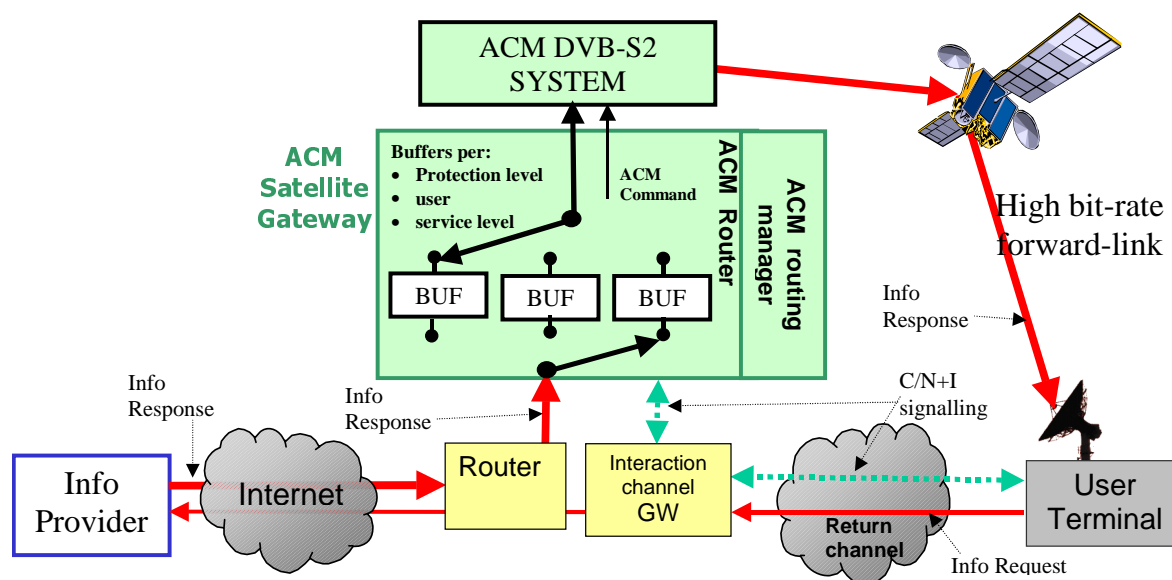

Figure H.7: Example of IP services using a DVB-S2 ACM link

The ACM router may interface with the DVB-S2 modulator:

- via a Single Generic Stream input and the ACM Command input. In this case the ACM router is independent from the DVB-S2 modulator, and may implement any routing policy. The DVB-S2 modulator immediately transmits the user data according to the ACM Command, therefore the loop delays may be minimized;
- via Multiple (Transport or Generic) Stream inputs, one per each active protection level (the ACM Command interface needs not be active). In this case the DVB-S2 Merger/Slicer partially covers the functionality of the ACM router.

This latter case is represented in more detail in figure H.8. The ACM router splits the users' packets per service level (priority) and per required protection level, and sends them to the multiple DVB-S2 input interfaces, each stream being permanently associated to a given protection level. Therefore each input stream merges the traffic of all the users needing a specific protection level, and its useful bit-rate may (slowly) change in time according to the traffic characteristics. According to table D.2, the Merger/Slicer in figure H.8 cyclically polls the input TS buffers, and conveys to the ACM modulator a block of "users" data ready to fill (or partially fill) a PLFRAME. A timeout may be defined in order to avoid long delays in each merger/slicer buffer.

Dotted boxes in figure H.8 address the specific case of IP services encapsulated in Transport Streams (Multi-Protocol Encapsulation - MPE), according to EN 301 192 [4]. In this case, K MPE gateways (GTW_i) are associated to K TS Multiplexers, to feed K DVB-S2 input streams (one per active protection level). Null-packet deletion, applied to each branch, reduces the transmitted bit-rate. The decoded TS, after null packets re-insertion, is a valid TS (the input stream synchronizer may optionally be activated). To fully exploit the potential ACM advantages, the additional control-loop delays introduced by the TS-specific equipment (Gateways, TS Muxes) should be minimized.

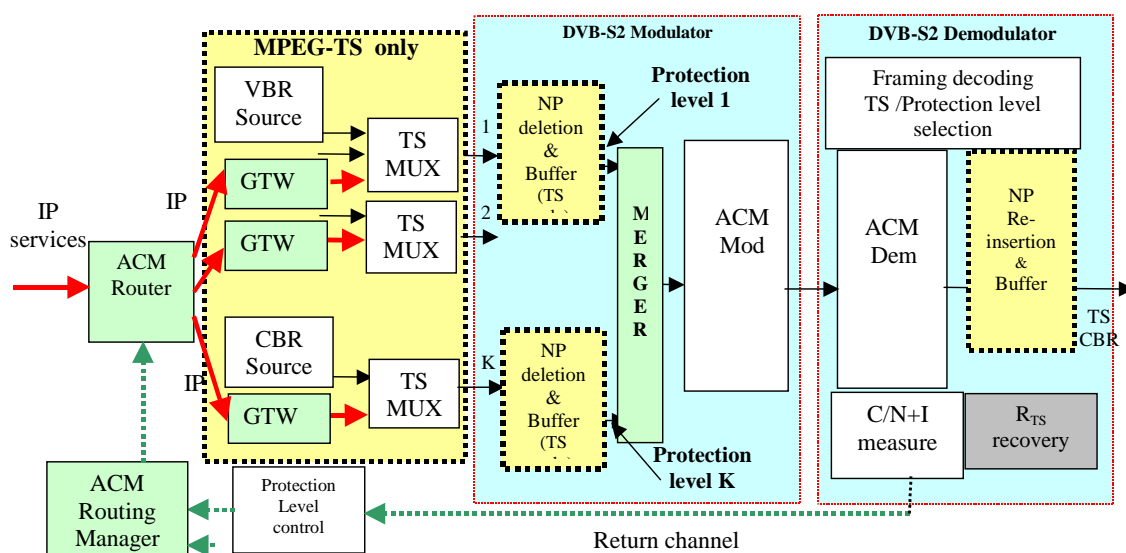

Figure H.8: IP Unicasting and ACM: Multiple input streams - uniform protection per stream (for Generic input Streams, GTWs, TS Muxes and null-packet deletion are not required)

H.6 Example performance of BC modes

Figure H.9 shows the C/N performance (linear AWGN channel) of the HP stream (DVB-S) and of LP stream (DVB-S2) versus the deviation angle θ , achieved under the simplifying assumption that the LP stream degrades the HP stream as a Gaussian noise of equal power (the C/N figures are according to EN 300 421 [2] for HP and according to table 13 - scaled to BPSK format - for LP, including 0,8 dB implementation margin for both streams). The points of intersection of the curves correspond to balanced HP and LP performance. For example, assuming an available $C/N = 10$ dB, adopting QPSK 7/8 for the HP DVB-S stream, $\theta = 12^\circ$ and rate 1/3 LP DVB-S2 stream, the total bit rate per unit bandwidth is 1,61 (HP) + 0,33 (LP) = 1,94 bit/s/Hz. In comparison, a DVB-S-only transmission would not be able to fully exploit the available C/N to maximize the total bit rate. The most significant advantages (additional bit-rate at a given C/N) of the BC DVB-S2 system over the legacy DVB-S system can be obtained for large available C/N (i.e. > 9 dB) and for spectral efficiencies above the maximum level offered by DVB-S (QPSK 7/8).

In practical cases, transmission parameters (code rates, θ) should be optimized on a case-by-case basis, taking into account the real channel characteristics.

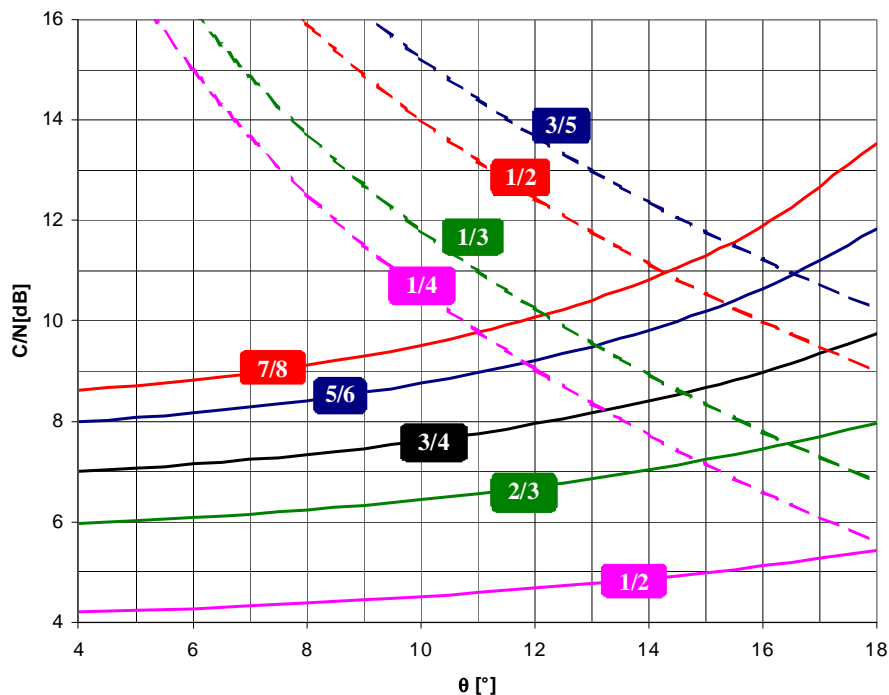

Figure H.9: Example performance of HP and LP backwards compatible streams versus θ

H.7 Satellite transponder models for simulations

For simulations, the "transparent" (i.e. non regenerative) satellite transponder model may be composed of an input filter (IMUX), a power amplifier (TWT or SSA) and an output filter (OMUX). Two amplifier models are here defined, the linearized TWTA (LTWTA) and the non-linearized TWTA. SSPAs have not been considered since they are less critical than TWTAs in terms of degradations.

The reference symbol rate with the specified IMUX/OMUX filter bandwidth is $R_s = 27,5$ Mbaud.

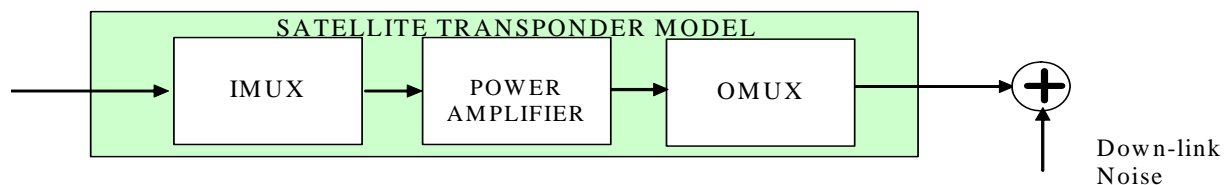

Figure H.10: Satellite transponder model

Figures H.11 and H.12 give the AM/AM and AM/PM TWTA characteristics.

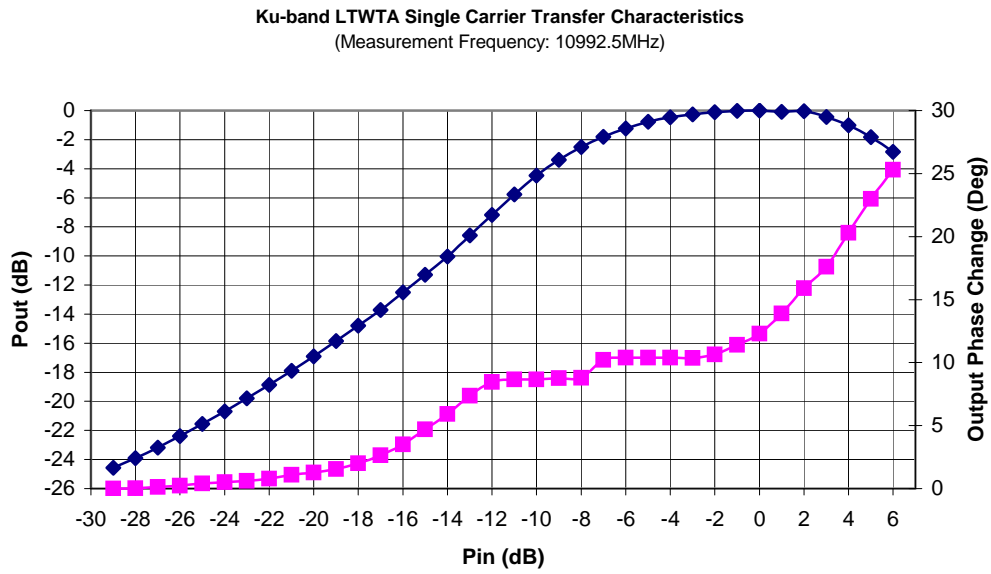

Figure H.11: Linearized TWTA characteristic

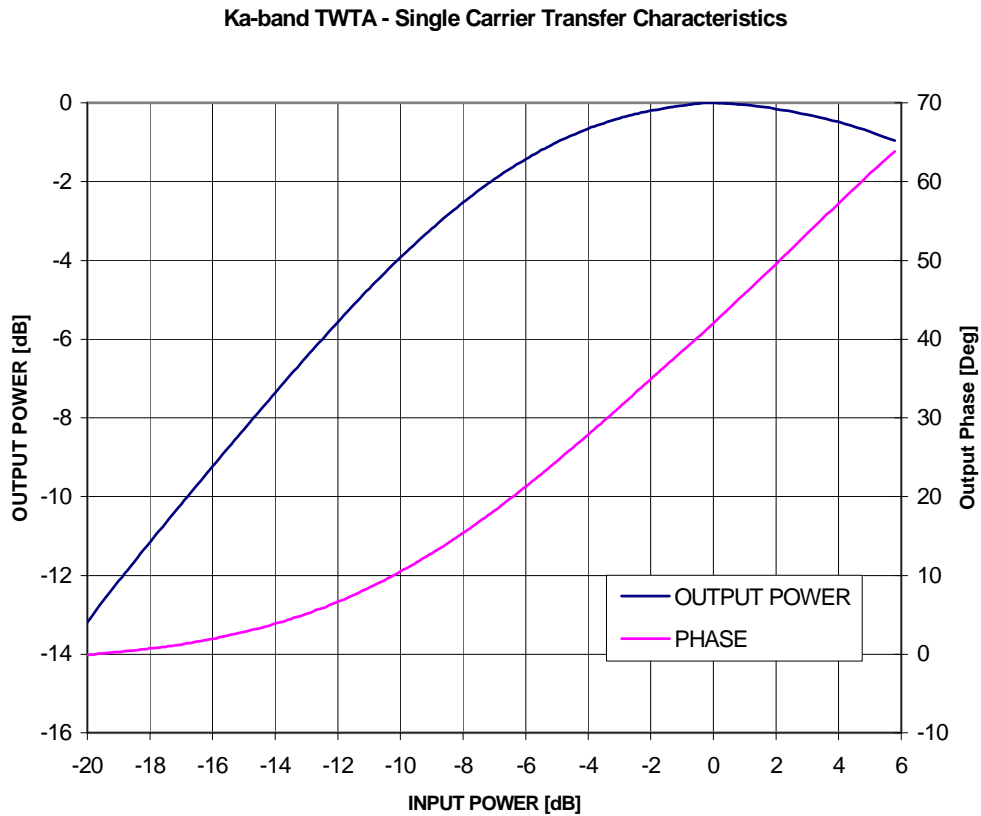

Figure H.12: Non-Linearized TWTA characteristic

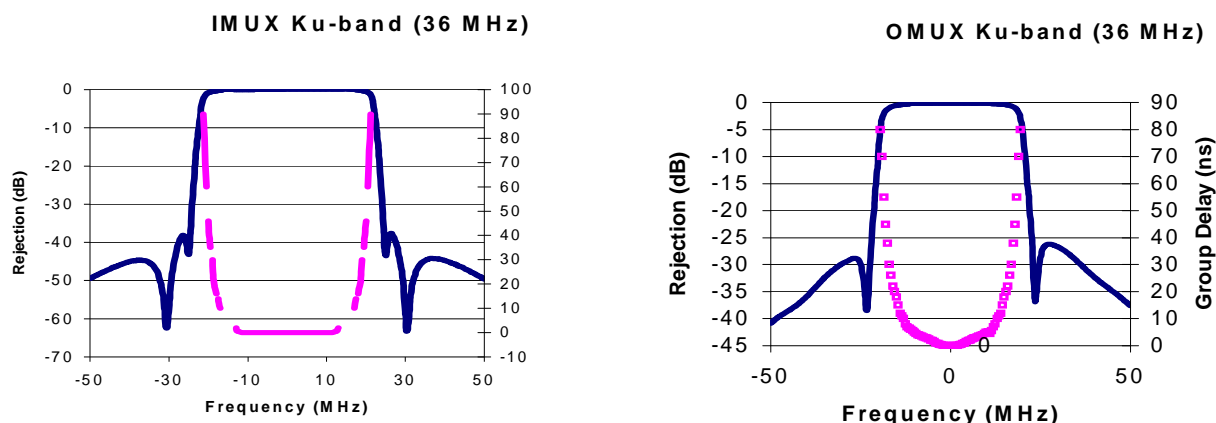

Figure H.13: IMUX and OMUX characteristics

Other transponder bandwidths BW [MHz] may be obtained by scaling the IMUX and OMUX characteristics:

- $R(f) = \text{Rejection} [f \times (\text{BW}/36)]$.
- $G(f) = [(36/\text{BW})] \times \text{Group-delay} [f \times (\text{BW}/36)]$.

The band-centre insertion loss is not indicated, but should be included in C_{SAT} for link budget computation.

H.8 Phase noise masks for simulations

The following phase noise masks for consumer reception systems may be used to evaluate the carrier recovery algorithms. The mask represents single side-band power spectral densities. The "aggregate" masks combine the phase noise contributions of the LNB and of the relevant Tuner. Other sources of phase noise within the chain (e.g. satellite transponder, up-link station, etc.) are usually negligible, and therefore the proposed masks may be considered as representative of the full chain.

Table H.2: Aggregate Phase Noise masks for Simulation (in dBc/Hz)

frequency \Rightarrow	100 Hz	1 kHz	10 kHz	100 kHz	1 MHz	> 10 MHz
Aggregate1 (typical)	-25	-50	-73	-93	-103	-114
Aggregate2 (critical)	-25	-50	-73	-85	-103	-114

Annex I (normative): Mode Adaptation input interfaces (optional)

I.1 Mode Adaptation input interface with separate signalling circuit (optional)

Mode Adaptation optional input interface (see figure 1) shall allow implementing the merging of multiple input streams by an external "Mode Adaptation Unit", respecting all the rules of the DVB-S2 specification. To allow to vary the transmission parameters to be adopted by the DVB-S2 modulator, it shall also transport the ACM command associated to each specific Data Field.

According to figure 3 Mode Adaptation shall be a sequence of Data Fields (according to clause 5.1.5), where each individual Data Field is preceded by a BBHEADER, according to clause 5.1.6 and to figure 3, and a Stream Adaptation command (SA command), transporting the transmission parameters to be adopted by the DVB-S2 modulator for each specific Data Field and corresponding BBHEADER.

"SA Command" (similar to the ACM command format, see clause D.1) shall carry the following information:

- MODCOD (5 bits, according to table 12).
- TYPE (2 bits, according to clause 5.5.2.3).
- CVALID (Command Valid).
- SEND (end of MA Packet).

The CVALID=active indicates the start of a MA Packet (MSB of the BB Header).

The transmission format specified by MODCOD and TYPE shall be applied to MA Packet received after CVALID=active and before SEND=active. When SEND=active, the modulator shall deliver user data immediately, even if a FECFRAME is not completed, by inserting the PADDING field (see clause 5.2.1). The user data included in the interval between CVALID=active and SEND=active shall not exceed the capacity of $(K_{bch}-80)$ bits, K_{bch} being the transmittable bits associated with a specific MODCOD and TYPE.

An example temporisation of SA Command is given in figure I.1, using a single serial interface to convey MODCOD, TYPE, CVALID(active= high-to-low transition) and SEND (active= low-to-high transition).

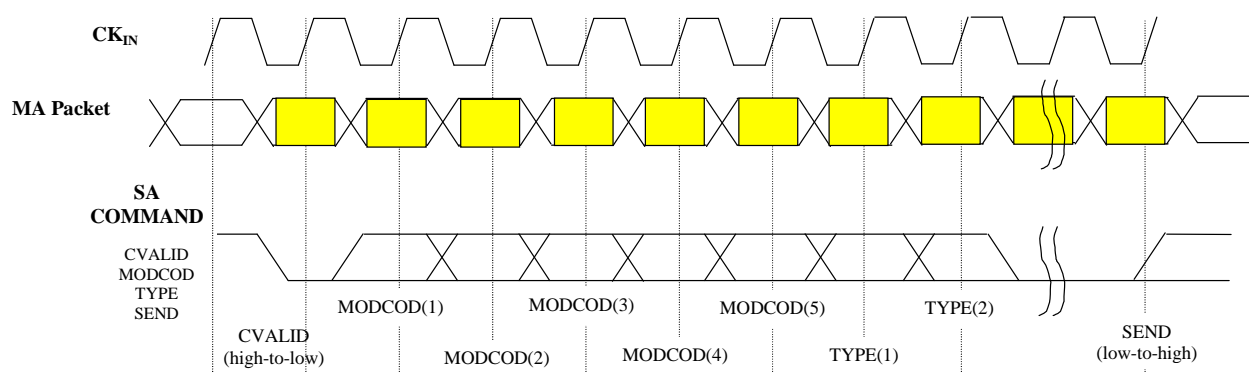

Figure I.1: Example temporisation of SA Command (serial format)

I.2 Mode Adaptation input interface with in-band signalling (optional)

Alternatively to clause I.1, the SA command can be mapped into a Transport Header to be prepended to the data generated by the external Mode Adaptation Unit. According to figure I.1, Mode Adaptation shall be a sequence of Data Fields (according to clause 5.1.5), where each individual Data Field is preceded by a BBHEADER, according to clause 5.1.6 and to figure 3, and a Transport Header.

The Transport Header shall consist of 2 bytes as illustrated in figure I. 2 and defined in table I.1. The first byte identifies the start of the Mode Adaptation packet and shall correspond to the sequence 0xB8. The second byte shall indicate the ACM command, defining the dynamic transmission parameters (MODCOD, TYPE) for the BBFRAME, according to table I. 2.

The BBFRAME shall consist of a valid BBHEADER, followed by the payload with length DFL, without padding bytes.

Stream Adaptation shall synchronize to the baseband frames (using the 0xB8 syncmarker and the DFL field inside the BBHEADER).

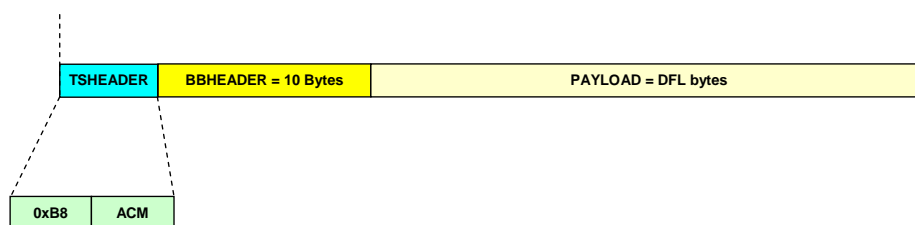

Transport Header : 2 Bytes

Figure I.2: Mode Adaptation format at the Mode Adaptation input interface

Table I.1: Transport Header format

Byte	Contents	Purpose
Byte 0	0xB8 syncmarker	For BBF synchronization
Byte 1	ACM command byte	Defines modcod, frametype and pilot insertion

Table I.2: ACM command byte definition (acm[0] is the least significant bit)

Bit fields	Description
Acm[4:0]	MODCOD (as defined in table 12)
Acm[5]	pilots configuration (0 = no pilots, 1 = pilots)
Acm[6]	FECFRAME sizes (0 = normal: 64 800 bits; 1 = short: 16 200 bits)
Acm[7]	reserved bit (set to 0)

Annex J (informative): Bibliography

R. De Gaudenzi, A. Guillen i Fabregas, A. Martinez Vicente, B. Ponticelli, "APSK Coded Modulation Schemes for Nonlinear Satellite Channels with High Power and Spectral Efficiency", in the Proc. of the AIAA Satellite Communication Systems Conference 2002, Montreal, Canada, May 2002, Paper # 1861.

U. Reimers, A. Morello, "DVB-S2, the second generation standard for satellite broadcasting and unicasting", International Journal on Satellite Communication Networks, 2004; 22.

M. Eroz, F.-W. Sun and L.-N. Lee, "DVB-S2 Low Density Parity Check Codes with near Shannon Limit Performance", International Journal on Satellite Communication Networks, 2004; 22.

E. Casini, R. De Gaudenzi, A. Ginesi, "DVB-S2 modem algorithms design and performance over typical satellite channels", International Journal on Satellite Communication Networks, 2004; 22.

F.-W. Sun Y. Jiang and L.-N. Lee "Frame synchronization and pilot structure for DVB-S2", International Journal on Satellite Communication Networks, 2004; 22.

A. Morello, R. Rinaldo, M. Vazquez-Castro, "DVB-S2 ACM modes for IP and MPEG unicast applications", International Journal on Satellite Communication Networks, 2004; 22.

E. Chen, J. L. Koslov, V. Mignone, J. Santoru, "DVB-S2 Backward-Compatible modes: a bridge between the present and the future", International Journal on Satellite Communication Networks, 2004; 22.

ETSI EN 300 744: "Digital Video Broadcasting (DVB); Framing structure, channel coding and modulation for digital terrestrial television".

CENELEC EN 50083-9: "Cable networks for television signals, sound signals and interactive services - Part 9: Interfaces for CATV/SMATV headends and similar professional equipment for DVB/MPEG-2 transport streams".

ETSI EN 300 468: "Digital Video Broadcasting (DVB); Specification for Service Information (SI) in DVB systems".

ETSI TBR 30 (1997): "Satellite Earth Stations and Systems (SES); Satellite News Gathering Transportable Earth Stations (SNG TES) operating in the 11-12/13-14 GHz frequency bands".

ETSI ETS 300 327: "Satellite Earth Stations and Systems (SES); Satellite News Gathering (SNG) Transportable Earth Stations (TES) (13-14/11-12 GHz)".

ETSI EN 300 673: "Electromagnetic compatibility and Radio spectrum Matters (ERM); ElectroMagnetic Compatibility (EMC) standard for Very Small Aperture Terminal (VSAT), Satellite News Gathering (SNG), Satellite Interactive Terminals (SIT) and Satellite User Terminals (SUT) Earth Stations operated in the frequency ranges between 4 GHz and 30 GHz in the Fixed Satellite Service (FSS)".

History

Document history		
V1.1.1	March 2005	Publication
V1.1.2	June 2006	Publication
V1.2.1	April 2009	One-step Approval Procedure OAP 20090822: 2009-04-24 to 2009-08-24
V1.2.1	August 2009	Publication