

Final draft **ETSI EN 302 304** V1.1.1 (2004-06)

---

*European Standard (Telecommunications series)*

## **Digital Video Broadcasting (DVB); Transmission System for Handheld Terminals (DVB-H)**

---

European Broadcasting Union



Union Européenne de Radio-Télévision



---

Reference

DEN/JTC-DVB-155

---

Keywords

broadcasting, digital, DVB, terminal, video, audio,  
data, mobile, TV

**ETSI**

650 Route des Lucioles  
F-06921 Sophia Antipolis Cedex - FRANCE

Tel.: +33 4 92 94 42 00 Fax: +33 4 93 65 47 16

Siret N° 348 623 562 00017 - NAF 742 C  
Association à but non lucratif enregistrée à la  
Sous-Préfecture de Grasse (06) N° 7803/88

---

**Important notice**

Individual copies of the present document can be downloaded from:

<http://www.etsi.org>

The present document may be made available in more than one electronic version or in print. In any case of existing or perceived difference in contents between such versions, the reference version is the Portable Document Format (PDF). In case of dispute, the reference shall be the printing on ETSI printers of the PDF version kept on a specific network drive within ETSI Secretariat.

Users of the present document should be aware that the document may be subject to revision or change of status. Information on the current status of this and other ETSI documents is available at

<http://portal.etsi.org/tb/status/status.asp>

If you find errors in the present document, send your comment to:

[editor@etsi.org](mailto:editor@etsi.org)

---

**Copyright Notification**

No part may be reproduced except as authorized by written permission.  
The copyright and the foregoing restriction extend to reproduction in all media.

© European Telecommunications Standards Institute 2004.

© European Broadcasting Union 2004.

All rights reserved.

**DECT™**, **PLUGTESTS™** and **UMTS™** are Trade Marks of ETSI registered for the benefit of its Members.  
**TIPHON™** and the **TIPHON logo** are Trade Marks currently being registered by ETSI for the benefit of its Members.  
**3GPP™** is a Trade Mark of ETSI registered for the benefit of its Members and of the 3GPP Organizational Partners.

---

# Contents

Intellectual Property Rights .....	4
Foreword.....	4
Introduction .....	5
Overview of the system.....	5
Time-slicing .....	7
MPE-FEC.....	7
4K mode and in-depth interleavers.....	7
DVB-H signalling .....	8
1 Scope .....	9
2 References .....	9
3 Definitions and abbreviations.....	9
3.1 Definitions .....	9
3.2 Abbreviations .....	10
4 System definition.....	10
4.1 General .....	10
4.2 Physical layer .....	10
4.3 Link layer .....	11
4.4 Service information .....	11
4.5 Single frequency networks (informative) .....	11
5 Use of the system (informative) .....	12
<b>Annex A (informative): Bibliography.....</b>	<b>13</b>
History .....	14

---

## Intellectual Property Rights

IPRs essential or potentially essential to the present document may have been declared to ETSI. The information pertaining to these essential IPRs, if any, is publicly available for **ETSI members and non-members**, and can be found in ETSI SR 000 314: "*Intellectual Property Rights (IPRs); Essential, or potentially Essential, IPRs notified to ETSI in respect of ETSI standards*", which is available from the ETSI Secretariat. Latest updates are available on the ETSI Web server (<http://webapp.etsi.org/IPR/home.asp>).

Pursuant to the ETSI IPR Policy, no investigation, including IPR searches, has been carried out by ETSI. No guarantee can be given as to the existence of other IPRs not referenced in ETSI SR 000 314 (or the updates on the ETSI Web server) which are, or may be, or may become, essential to the present document.

---

## Foreword

This European Standard (Telecommunications series) has been produced by Joint Technical Committee (JTC) Broadcast of the European Broadcasting Union (EBU), Comité Européen de Normalisation ELEctrotechnique (CENELEC) and the European Telecommunications Standards Institute (ETSI), and is now submitted for the ETSI standards One-step Approval Procedure.

NOTE: The EBU/ETSI JTC Broadcast was established in 1990 to co-ordinate the drafting of standards in the specific field of broadcasting and related fields. Since 1995 the JTC Broadcast became a tripartite body by including in the Memorandum of Understanding also CENELEC, which is responsible for the standardization of radio and television receivers. The EBU is a professional association of broadcasting organizations whose work includes the co-ordination of its members' activities in the technical, legal, programme-making and programme-exchange domains. The EBU has active members in about 60 countries in the European broadcasting area; its headquarters is in Geneva.

European Broadcasting Union  
 CH-1218 GRAND SACONNEX (Geneva)  
 Switzerland  
 Tel: +41 22 717 21 11  
 Fax: +41 22 717 24 81

Founded in September 1993, the DVB Project is a market-led consortium of public and private sector organizations in the television industry. Its aim is to establish the framework for the introduction of MPEG-2 based digital television services. Now comprising over 200 organizations from more than 25 countries around the world, DVB fosters market-led systems, which meet the real needs, and economic circumstances, of the consumer electronics and the broadcast industry.

<b>Proposed national transposition dates</b>	
Date of latest announcement of this EN (doa):	3 months after ETSI publication
Date of latest publication of new National Standard or endorsement of this EN (dop/e):	6 months after doa
Date of withdrawal of any conflicting National Standard (dow):	6 months after doa

---

# Introduction

## Overview of the system

The present document specifies the transmission system using ETSI Digital Video Broadcasting standards to provide an efficient way of carrying multimedia services over digital terrestrial broadcasting networks to handheld terminals (DVB-H). It identifies ETSI standards in which functionalities and parameters shall be implemented in order to deliver DVB-H compliant services.

Although the DVB-T transmission system has proven its ability to serve fixed, portable and mobile terminals, handheld terminals (defined as a light battery powered apparatus) require specific features from the transmission system serving them:

- as battery powered, the transmission system shall offer them the possibility to repeatedly power off some part of the reception chain to increase the battery usage duration;
- as targeting nomadic users, the transmission system shall ease access to the DVB-H services when receivers leave a given transmission cell and enter a new one;
- as expected to serve various situations of use (indoor and outdoor, pedestrian and inside moving vehicle), the transmission system shall offer sufficient flexibility/scalability to allow reception of DVB-H services at various speeds, while optimizing transmitter coverage;
- as services are expected to be delivered in an environment suffering high levels of man-made noise, the transmission system shall offer the means to mitigate their effects on the receiving capabilities;
- as DVB-H aims to provide a generic way to serve handheld terminals, in various part of the world, the transmission system shall offer the flexibility to be used in various transmission bands and channel bandwidths.

A full DVB-H system is defined by combining elements in the physical and link layers as well as service information. DVB-H makes use of the following technology elements for the link layer and the physical layer:

- Link layer:
  - time-slicing in order to reduce the average power consumption of the terminal and enabling smooth and seamless frequency handover;
  - forward error correction for multiprotocol encapsulated data (MPE-FEC) for an improvement in C/N-performance and Doppler performance in mobile channels, also improving tolerance to impulse interference.

- Physical layer:

DVB-T (EN 300 744 [1]) with the following technical elements specifically targeting DVB-H use:

- DVB-H signalling in the TPS-bits to enhance and speed up service discovery. Cell identifier is also carried on TPS-bits to support quicker signal scan and frequency handover on mobile receivers;
- 4K-mode for trading off mobility and SFN cell size, allowing single antenna reception in medium SFNs at very high speed, adding thus flexibility in the network design;
- in-depth symbol interleaver for the 2K and 4K-modes for further improving their robustness in mobile environment and impulse noise conditions.

**NOTE:** As stated in the present document, to provide DVB-H services time-slicing, cell identifier and DVB-H signalling are mandatory; all other technical elements may be combined arbitrarily.

It should be mentioned that both time-slicing and MPE-FEC technology elements, as they are implemented on the link layer, do not touch the DVB-T physical layer in any way. It is also important to notice that the payload of DVB-H are IP-datagrams or other network layer datagrams encapsulated into MPE-sections.

The conceptual structure of a DVB-H receiver is depicted in figure 1. It includes a DVB-H demodulator and a DVB-H terminal. The DVB-H demodulator includes a DVB-T demodulator, a time-slicing module and a MPE-FEC module.

- The DVB-T demodulator recovers the MPEG-2 Transport Stream packets from the received DVB-T (EN 300 744 [1]) RF signal. It offers three transmission modes 8K, 4K and 2K with the corresponding Transmitter Parameter Signalling (TPS). Note that the 4K mode, the in-depth interleavers and the DVB-H signalling have been defined while elaborating the DVB-H standard.
- The time-slicing module, provided by DVB-H, aims to save receiver power consumption while enabling to perform smooth and seamless frequency handover.
- The MPE-FEC module, provided by DVB-H, offers over the physical layer transmission, a complementary forward error correction allowing the receiver to cope with particularly difficult receiving situations.

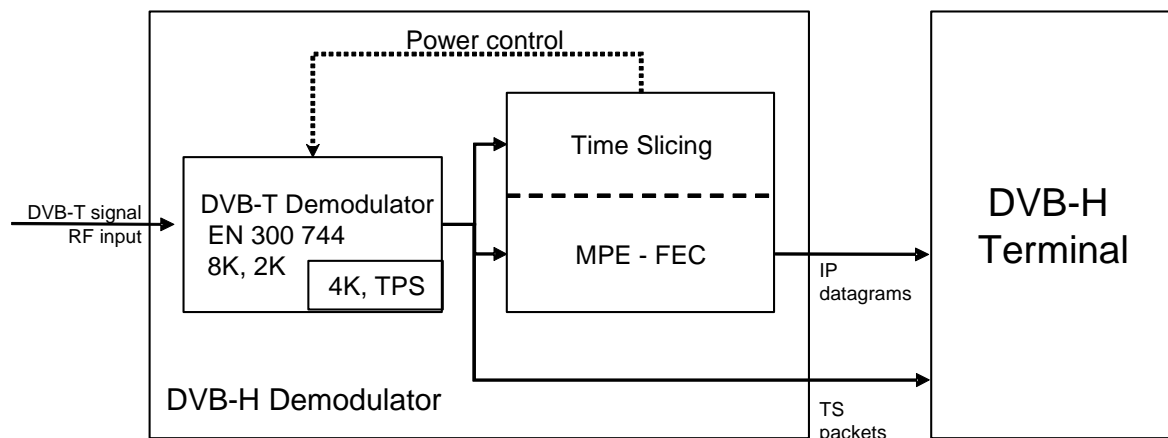

Figure 1: Conceptual structure of a DVB-H receiver

An example of using DVB-H for transmission of IP-services is given in figure 2. In this example, both traditional MPEG-2 services and time-sliced "DVB-H services" are carried over the same multiplex. The handheld terminal decodes/uses IP-services only.

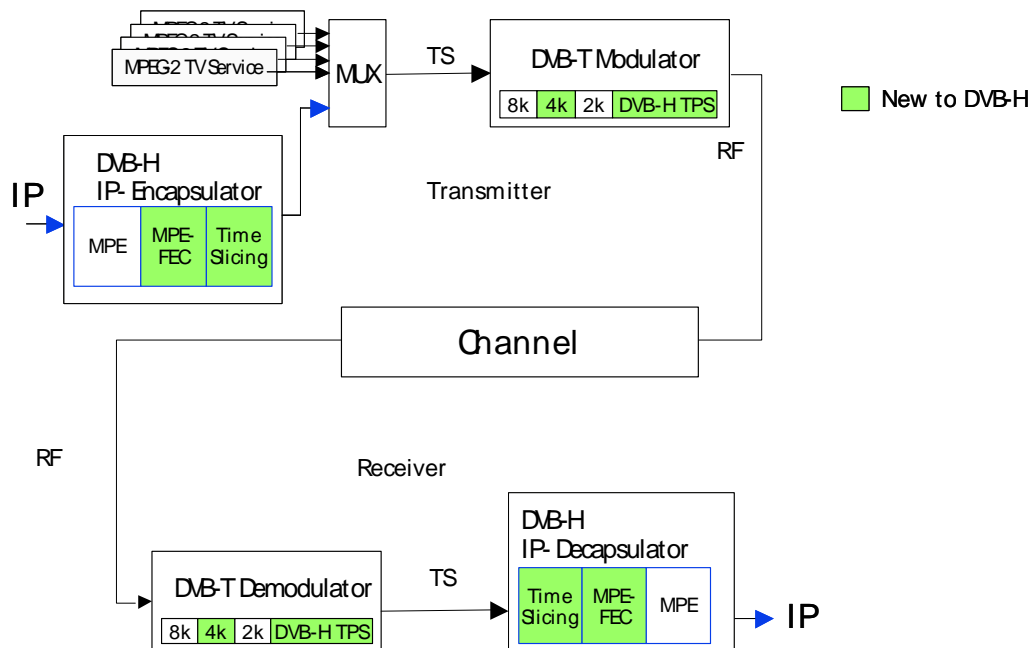

Figure 2: A conceptual description of using a DVB-H system (sharing a MUX with MPEG2 services)

## Time-slicing

The objective of time-slicing is to reduce the average power consumption of the terminal and enable smooth and seamless service handover. Time-slicing consists of sending data in bursts using significantly higher instantaneous bit rate compared to the bit rate required if the data were transmitted using traditional streaming mechanisms.

To indicate to the receiver when to expect the next burst, the time ( $\Delta t$ ) to the beginning of the next burst is indicated within the burst. Between the bursts, data of the elementary stream is not transmitted, allowing other elementary streams to use the bandwidth otherwise allocated. Time-slicing enables a receiver to stay active only a fraction of the time, while receiving bursts of a requested service. Note that the transmitter is constantly on (i.e. the transmission of the transport stream is not interrupted).

Time-slicing also supports the possibility to use the receiver to monitor neighbouring cells during the off-times (between bursts). By accomplishing the switching of the reception from one transport stream to another during an off period it is possible to accomplish a quasi-optimum handover decision as well as seamless service handover.

Time-slicing is always used in DVB-H as is defined in the main body of the present document (see clause 4.3).

## MPE-FEC

The objective of the MPE-FEC is to improve the C/N- and Doppler performance in mobile channels and to improve the tolerance to impulse interference.

This is accomplished through the introduction of an additional level of error correction at the MPE layer. By adding parity information calculated from the datagrams and sending this parity data in separate MPE-FEC sections, error-free datagrams can be output after MPE-FEC decoding despite a very bad reception condition. The use of MPE-FEC is optional as defined in the main body of the present document (see clause 4.3).

With MPE-FEC a flexible amount of the transmission capacity is allocated to parity overhead. For a given set of transmission parameters providing 25 % of parity overhead, the MPE-FEC may require about the same C/N as a receiver with antenna diversity.

The MPE-FEC overhead can be fully compensated by choosing a slightly weaker transmission code rate, while still providing far better performance than DVB-T (without MPE-FEC) for the same throughput. This MPE-FEC scheme should allow high-speed single antenna DVB-T reception using 8K/16-QAM or even 8K/64-QAM signals. In addition MPE-FEC provides good immunity to impulse interference.

The MPE-FEC, as standardized, works in such a way that MPE-FEC ignorant (but MPE capable) receivers will be able to receive the data stream in a fully backwards-compatible way, provided it does not reject the used stream\_type.

## 4K mode and in-depth interleavers

The objective of the 4K mode is to improve network planning flexibility by trading off mobility and SFN size. To further improve robustness of the DVB-T 2K and 4K modes in a mobile environment and impulse noise reception conditions, an in-depth symbol interleaver is also standardized.

The additional 4K transmission mode is an interpolation of the parameters defined for the 2K and 8K transmission modes. It aims to offer an additional trade-off between Single Frequency Network (SFN) cell size and mobile reception performance, providing an additional degree of flexibility for network planning.

Terms of the trade-off can be expressed as follows:

- The DVB-T 8K mode can be used both for single transmitter operation and for small, medium and large SFNs. It provides a Doppler tolerance allowing high speed reception.
- The DVB-T 4K mode can be used both for single transmitter operation and for small and medium SFNs. It provides a Doppler tolerance allowing very high speed reception.
- The DVB-T 2K mode is suitable for single transmitter operation and for small SFNs with limited transmitter distances. It provides a Doppler tolerance allowing extremely high speed reception.

For 2K and 4K modes the in-depth interleavers increase the flexibility of the symbol interleaving, by decoupling the choice of the inner interleaver from the transmission mode used. This flexibility allows a 2K or 4K signal to take benefit of the memory of the 8K symbol interleaver to effectively quadruple (for 2K) or double (for 4K) the symbol interleaver depth to improve reception in fading channels. This provides also an extra level of protection against short noise impulses caused by, e.g. ignition interference and various domestic electrical appliances.

4K and in-depth interleavers affect the physical layer, however their implementations do not imply large increase in equipment (i.e. logic gates and memory) over the version 1.4.1 of DVB-T standard EN 300 744 [1] for either transmitters or receivers. A typical mobile demodulator already incorporates enough RAM and logic for the management of 8K signals, which already exceed that required for 4K operation.

The emitted spectrum of the 4K mode is similar to the 2K and 8K modes thus no changes in transmitter filters are envisaged.

## DVB-H signalling

The objective of the DVB-H signalling is to provide a robust and easy-to-access signalling to the DVB-H receivers, thus to enhancing and speeding up service discovery.

TPS is a very robust signalling channel allowing TPS-lock in a demodulator with very low C/N-values. TPS provides also a faster way to access signalling than demodulating and decoding the Service Information (SI) or the MPE-section header.

The DVB-H system uses two TPS bits to indicate the presence of time-slicing and optional MPE-FEC. Besides these, the signalling of the 4K mode and the use of in-depth symbol interleavers are also standardized.



---

# 1 Scope

The present document specifies DVB-H by referencing ETSI Digital Video Broadcasting standards and by their use.

---

## 2 References

The following documents contain provisions which, through reference in this text, constitute provisions of the present document.

- References are either specific (identified by date of publication and/or edition number or version number) or non-specific.
- For a specific reference, subsequent revisions do not apply.
- For a non-specific reference, the latest version applies.

Referenced documents which are not found to be publicly available in the expected location might be found at <http://docbox.etsi.org/Reference>.

- |     |   |
|-----|---|
| [1] | ETSI EN 300 744: "Digital Video Broadcasting (DVB); Framing structure, channel coding and modulation for digital terrestrial television". (DVB-T) |
| [2] | ETSI EN 300 468: "Digital Video Broadcasting (DVB); Specification for Service Information (SI) in DVB systems". (DVB-SI)                          |
| [3] | ETSI EN 301 192: "Digital Video Broadcasting (DVB); DVB specification for data broadcasting". (DVB-DATA)  |
| [4] | ETSI TS 101 191: "Digital Video Broadcasting (DVB); DVB mega-frame for Single Frequency Network (SFN) synchronization".                           |
| [5] | ISO/IEC 7498-1: "Information technology - Open Systems Interconnection - Basic Reference Model: The Basic Model".                                 |
- 

## 3 Definitions and abbreviations

### 3.1 Definitions

For the purposes of the present document, the following terms and definitions apply:

**burst size:** number of network layer bits within a time sliced burst

**datagram:** network layer packet with full address information enabling it to be routed to the endpoint without further information

**DVB-H services:** content carried by the DVB-H system

**IP/MAC stream:** data stream including an address header containing an IP and/or MAC address

NOTE: IP/MAC stream is encapsulated in an MPEG-2 Transport Stream multiplex. An example would be an IP multicast stream conveyed in MPE sections.

**off-time:** the time between two time-sliced bursts

NOTE: During the off-time, no transport\_packets are delivered on relevant elementary stream.

**MPE-FEC:** method to deliver additional Forward Error Correction (FEC) to datagrams delivered in MPE sections, as defined in EN 301 192 [3]

**network layer:** OSI layer as defined in ISO/IEC 7498-1 [5]

**time-slicing:** method to deliver MPE sections and MPE-FEC sections in bursts, as defined in EN 301 192 [3]

## 3.2 Abbreviations

For the purposes of the present document, the following abbreviations apply:

DVB-H	DVB Handheld system
DVB-T	DVB Terrestrial transmission standard (EN 300 744 [1])
FEC	Forward Error Correction
INT	IP/MAC Notification Table
IP	Internet Protocol
MAC	Media Access Control
MPE	Multiprotocol Encapsulation
MPEG-2	Moving Picture Experts Group
MUX	Multiplexer
RAM	Random
RF	Radio Frequency
SFN	Single Frequency Network
TPS	Transmission Parameter Signalling

---

## 4 System definition

### 4.1 General

DVB-H is a broadcast transmission system for datagrams. These datagrams may be IP or other datagrams and may contain data that pertain to multimedia services, file downloading services, or to other services not mentioned here.

The objective of DVB-H is to provide efficient means for carrying these multimedia data over digital terrestrial broadcasting networks to handheld terminals. The main characteristics with regard to efficiency are considered to be constraints on power supply and varying transmission conditions due to mobility.

DVB-H details the specification of:

- the physical layer;
- the link layer;
- the service information.

Recommendations about the synchronization of SFNs in DVB-H are also provided.

Further information and recommendations about how to use and select the appropriate parameters of DVB-H are provided in the text and through documents that are listed in the bibliography.

### 4.2 Physical layer

DVB-H shall follow EN 300 744 [1].

The optional cell\_id and DVB-H signalling defined in EN 300 744 [1] shall be used for DVB-H.

NOTE 1: All parameter configurations of [1] using cell\_id and DVB-H signalling are allowed for DVB-H. However, some parts of [1] are specified specifically targeting DVB-H use. These are: DVB-H signalling, 4K mode with native interleaver, in-depth interleaver for 2K and 4K, 5 MHz channel bandwidth for use in non-broadcast bands.

NOTE 2: The specific issues of DVB-H regarding use of 4K mode, use of in-depth symbol interleavers and use of TPS bits are handled in annex F of EN 300 744 [1]. The 5 MHz channel bandwidth operation is specified in annex G of EN 300 744 [1].

## 4.3 Link layer

Datagrams shall be encapsulated using Multi-Protocol Encapsulation (MPE) as specified in EN 301 192 [3].

Time-slicing shall be used on elementary streams carrying MPE sections. Time-slicing is specified in EN 301 192 [3].

MPE-FEC should be used on elementary streams using time-slicing. MPE-FEC is specified in EN 301 192 [3].

## 4.4 Service information

DVB-H shall follow EN 300 468.

NOTE: The service information has terrestrial delivery system descriptor (see [2], clause 6.2.13.3) which includes DVB-H specific elements.

The delivery system descriptor shall be the `terrestrial_delivery_system_descriptor`, specified in EN 300 468 [2].

The cell list descriptor, as defined in EN 300 468 [2], shall be used and be complete.

The use of time-slicing and the optional MPE-FEC shall be announced using the `time_slice_fec_identifier_descriptor`, as specified in EN 301 192 [3].

To support detection of DVB-H system services on a transport stream, the following applies:

- The IP/MAC streams delivering services of the DVB-H system shall be announced on the IP/MAC Notification Table (INT) carried on the actual transport stream. INT is specified in EN 301 192 [3].

To support handover between transport streams with same network ID, the following applies:

- If the coverage area of transport streams carrying DVB-H services, and belonging to the same network, are intersecting, INT on such transport streams should announce IP/MAC streams on each of the intersecting transport stream(s) carrying DVB-H services.

To support handover between transport streams carrying DVB-H services, and belonging to different networks, the following applies:

- If the coverage areas of transport streams carrying DVB-H services are intersecting, and these transport streams belong to different networks, INT on such transport streams should announce IP/MAC streams on each of the intersecting transport stream(s) carrying DVB-H services.

If the coverage area of transport streams, carrying DVB-H services and belonging to different networks, are intersecting, each of such transport streams should carry valid `NIT_other(s)` announcing the network(s) with intersecting transport streams(s), one or more carrying DVB-H services.

## 4.5 Single frequency networks (informative)

As regards synchronization of SFNs the DVB-H system may use methods described in TS 101 191 [4].

NOTE 1: The DVB-H system is fully compatible with SFN operation and may use exactly the same methods for modulator/transmitter synchronization as other DVB-T networks. To support `tps_mip` signalling related to interleaving and DVB-H signalling, bits  $P_2$  and bits  $P_{15}$ ,  $P_{16}$  should be used as defined in TS 101 191 [4].

NOTE 2: If the 5 MHz option of the DVB-T standard is used together with TS 101 191 [4] the bandwidth is optionally signalled by the bandwidth function.

---

## 5 Use of the system (informative)

The principles for implementing DVB-T can be found in TR 101 190 (see bibliography).

---

## Annex A (informative): Bibliography

- ETSI TR 101 190: "Digital Video Broadcasting (DVB); Implementation guidelines for DVB terrestrial services; Transmission aspects".

---

## History

<b>Document history</b>		
V1.1.1	June 2004	One-step Approval Procedure OAP 20041022: 2004-06-23 to 2004-10-22