

Final draft **ETSI EN 302 296** V1.1.1 (2004-11)

---

*Candidate Harmonized European Standard (Telecommunications series)*

**Electromagnetic compatibility  
and Radio spectrum Matters (ERM);  
Transmitting equipment for  
the digital television broadcast service,  
Terrestrial (DVB-T);  
Harmonized EN under article 3.2  
of the R&TTE Directive**

---



---

Reference

DEN/ERM-TG17-003

---

Keywords

broadcasting, digital, radio, regulation, terrestrial,  
transmitter, TV, video

**ETSI**

650 Route des Lucioles  
F-06921 Sophia Antipolis Cedex - FRANCE

Tel.: +33 4 92 94 42 00 Fax: +33 4 93 65 47 16

Siret N° 348 623 562 00017 - NAF 742 C  
Association à but non lucratif enregistrée à la  
Sous-Préfecture de Grasse (06) N° 7803/88

---

**Important notice**

Individual copies of the present document can be downloaded from:

<http://www.etsi.org>

The present document may be made available in more than one electronic version or in print. In any case of existing or perceived difference in contents between such versions, the reference version is the Portable Document Format (PDF). In case of dispute, the reference shall be the printing on ETSI printers of the PDF version kept on a specific network drive within ETSI Secretariat.

Users of the present document should be aware that the document may be subject to revision or change of status. Information on the current status of this and other ETSI documents is available at

<http://portal.etsi.org/tb/status/status.asp>

If you find errors in the present document, please send your comment to one of the following services:

[http://portal.etsi.org/chaicor/ETSI\\_support.asp](http://portal.etsi.org/chaicor/ETSI_support.asp)

---

**Copyright Notification**

No part may be reproduced except as authorized by written permission.  
The copyright and the foregoing restriction extend to reproduction in all media.

© European Telecommunications Standards Institute 2004.  
All rights reserved.

**DECT**<sup>TM</sup>, **PLUGTESTS**<sup>TM</sup> and **UMTS**<sup>TM</sup> are Trade Marks of ETSI registered for the benefit of its Members.  
**TIPHON**<sup>TM</sup> and the **TIPHON logo** are Trade Marks currently being registered by ETSI for the benefit of its Members.  
**3GPP**<sup>TM</sup> is a Trade Mark of ETSI registered for the benefit of its Members and of the 3GPP Organizational Partners.

# Contents

Intellectual Property Rights .....	4
Foreword.....	4
Introduction .....	5
1 Scope .....	7
2 References .....	7
3 Definitions, symbols and abbreviations .....	8
3.1 Definitions .....	8
3.2 Symbols.....	9
3.3 Abbreviations .....	9
4 Technical requirements specifications .....	9
4.1 Environmental profile.....	9
4.2 Antenna port measurements .....	10
4.2.1 Spurious emissions .....	10
4.2.1.1 Definition .....	10
4.2.1.2 Method of measurement (essential test suite) .....	10
4.2.1.2.1 Initial conditions.....	10
4.2.1.2.2 Procedure.....	10
4.2.1.2.3 Test requirements .....	10
4.2.1.3 Limit.....	10
4.2.2 Out-of-band emissions.....	12
4.2.2.1 Definition .....	12
4.2.2.2 Method of measurement (essential test suite) .....	12
4.2.2.2.1 Initial conditions .....	12
4.2.2.2.2 Procedure.....	13
4.2.2.2.3 Test requirements .....	13
4.2.2.3 Limit.....	13
4.3 Enclosure port measurements (radiated emissions).....	17
4.3.1 Cabinet radiation.....	17
4.3.1.1 Definition .....	17
4.3.1.2 Method of test (essential test suite) .....	17
4.3.1.2.1 Initial conditions .....	17
4.3.1.2.2 Procedure.....	17
4.3.1.2.3 Test requirements .....	17
4.3.1.3 Limits .....	17
4.4 Measurement uncertainties .....	18
<b>Annex A (normative): General measuring arrangements .....</b>	<b>19</b>
A.1 Testing arrangements for antenna port measurements .....	19
A.1.1 Spurious emissions .....	19
A.1.2 Out-of-band emissions .....	20
A.1.3 Test frequency range .....	20
A.1.4 Test modulating signal .....	21
A.2 Testing arrangements for enclosure port (radiated emissions) measurements .....	21
<b>Annex B (informative): Bibliography.....</b>	<b>22</b>
<b>Annex C (informative): The EN title in the official languages .....</b>	<b>23</b>
History .....	24

---

## Intellectual Property Rights

IPRs essential or potentially essential to the present document may have been declared to ETSI. The information pertaining to these essential IPRs, if any, is publicly available for **ETSI members and non-members**, and can be found in ETSI SR 000 314: "*Intellectual Property Rights (IPRs); Essential, or potentially Essential, IPRs notified to ETSI in respect of ETSI standards*", which is available from the ETSI Secretariat. Latest updates are available on the ETSI Web server (<http://webapp.etsi.org/IPR/home.asp>).

Pursuant to the ETSI IPR Policy, no investigation, including IPR searches, has been carried out by ETSI. No guarantee can be given as to the existence of other IPRs not referenced in ETSI SR 000 314 (or the updates on the ETSI Web server) which are, or may be, or may become, essential to the present document.

---

## Foreword

This Candidate Harmonized European Standard (Telecommunications series) has been produced by ETSI Technical Committee Electromagnetic compatibility and Radio spectrum Matters (ERM), and is now submitted for the Vote phase of the ETSI standards Two-step Approval Procedure.

The present document has been produced by ETSI in response to a mandate from the European Commission issued under Council Directive 98/34/EC [1] (as amended) laying down a procedure for the provision of information in the field of technical standards and regulations.

The present document is intended to become a Harmonized Standard, the reference of which will be published in the Official Journal of the European Communities referencing the Directive 1999/5/EC [2] of the European Parliament and of the Council of 9 March 1999 on radio equipment and telecommunications terminal equipment and the mutual recognition of their conformity ("the R&TTE Directive").

<b>Proposed national transposition dates</b>	
Date of latest announcement of this EN (doa):	3 months after ETSI publication
Date of latest publication of new National Standard or endorsement of this EN (dop/e):	6 months after doa
Date of withdrawal of any conflicting National Standard (dow):	18 months after doa

## Introduction

The present document is part of a set of standards designed to fit in a modular structure to cover all radio and telecommunications terminal equipment under the R&TTE Directive [2]. Each standard is a module in the structure. The modular structure is shown in figure 1.

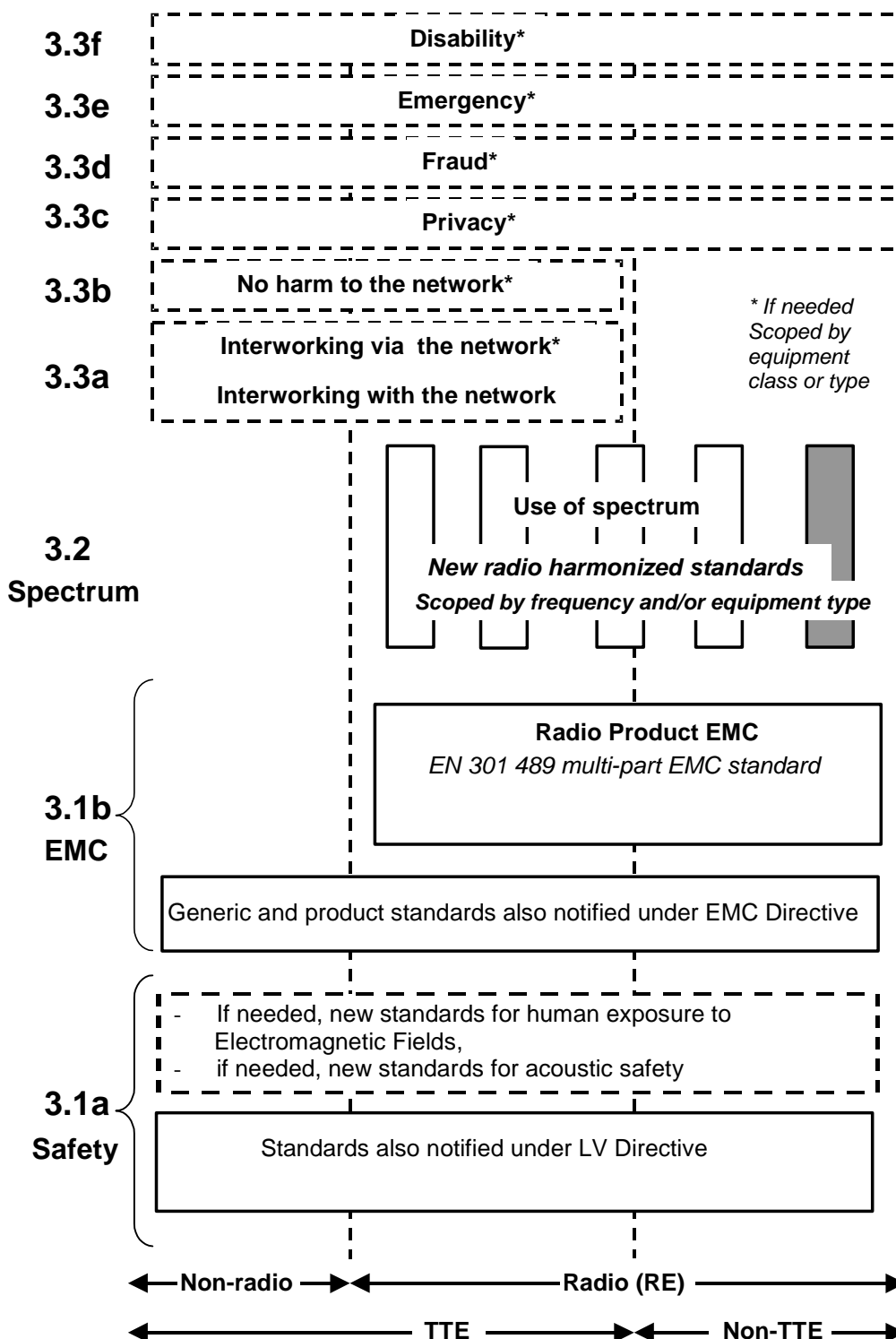

Figure 1: Modular structure for the various standards used under the R&TTE Directive [2]

The left hand edge of the figure 1 shows the different clauses of article 3 of the R&TTE Directive [2].

For article 3.3 various horizontal boxes are shown. Dotted lines indicate that at the time of publication of the present document essential requirements in these areas have to be adopted by the Commission. If such essential requirements are adopted, and as far and as long as they are applicable, they will justify individual standards whose scope is likely to be specified by function or interface type.

The vertical boxes show the standards under article 3.2 for the use of the radio spectrum by radio equipment. The scopes of these standards are specified either by frequency (normally in the case where frequency bands are harmonized) or by radio equipment type.

For article 3.1b the diagram shows EN 301 489, the multi-part product EMC standard for radio used under the EMC Directive [3].

For article 3.1a the diagram shows the existing safety standards currently used under the LV Directive [4] and new standards covering human exposure to electromagnetic fields. New standards covering acoustic safety may also be required.

The bottom of the figure shows the relationship of the standards to radio equipment and telecommunications terminal equipment. A particular equipment may be radio equipment, telecommunications terminal equipment or both. A radio spectrum standard will apply if it is radio equipment. An article 3.3 standard will apply as well only if the relevant essential requirement under the R&TTE Directive [2] is adopted by the Commission and if the equipment in question is covered by the scope of the corresponding standard. Thus, depending on the nature of the equipment, the essential requirements under the R&TTE Directive [2] may be covered in a set of standards.

The modularity principle has been taken because:

- it minimizes the number of standards needed. Because equipment may, in fact, have multiple interfaces and functions it is not practicable to produce a single standard for each possible combination of functions that may occur in an equipment;
- it provides scope for standards to be added:
  - under article 3.2 when new frequency bands are agreed; or
  - under article 3.3 should the Commission take the necessary decisionswithout requiring alteration of standards that are already published;
- it clarifies, simplifies and promotes the usage of Harmonized Standards as the relevant means of conformity assessment.

Other document directly associated with the present document:

- EN 301 489-14 [5].

---

# 1 Scope

The present document applies to transmitting equipment for the terrestrial digital television broadcasting service.

The types of equipment covered by the present document are as follows:

- Transmitting equipment for digital television broadcasting service, with 7 MHz and 8 MHz RF channel bandwidths, operating in the CEPT frequency bands. These frequencies are currently within the television Bands III, IV and V.

The present document is intended to cover the provisions of article 3.2 of Directive 1999/5/EC [2] (R&TTE Directive), which states that "... radio equipment shall be so constructed that it effectively uses the spectrum allocated to terrestrial/space radio communications and orbital resources so as to avoid harmful interference".

In addition to the present document, other ENs that specify technical requirements in respect of essential requirements under other parts of article 3 of the R&TTE Directive [2] may apply to equipment within the scope of the present document.

NOTE: A list of such ENs is included on the web site <http://www.newapproach.org>.

---

# 2 References

The following documents contain provisions which, through reference in this text, constitute provisions of the present document.

- References are either specific (identified by date of publication and/or edition number or version number) or non-specific.
- For a specific reference, subsequent revisions do not apply.
- For a non-specific reference, the latest version applies.

Referenced documents which are not found to be publicly available in the expected location might be found at <http://docbox.etsi.org/Reference>.

- [1] Directive 98/34/EC of the European Parliament and of the Council of 22 June 1998 laying down a procedure for the provision of information in the field of technical standards and regulations.
- [2] Directive 1999/5/EC of the European Parliament and of the Council of 9 March 1999 on radio equipment and telecommunications terminal equipment and the mutual recognition of their conformity (R&TTE Directive).
- [3] Council Directive 89/336/EEC of 3 May 1989 on the approximation of the laws of the Member States relating to electromagnetic compatibility (EMC Directive).
- [4] Council Directive 73/23/EEC of 19 February 1973 on the harmonization of the laws of the Member States relating to electrical equipment designed for use within certain voltage limits (LV Directive).
- [5] ETSI EN 301 489-14 (V1.2.1): "Electromagnetic compatibility and Radio spectrum Matters (ERM); ElectroMagnetic Compatibility (EMC) standard for radio equipment and services; Part 14: Specific conditions for analogue and digital terrestrial TV broadcasting service transmitters".
- [6] ETSI EN 300 744 (V1.4.1): "Digital Video Broadcasting (DVB); Framing structure, channel coding and modulation for digital terrestrial television".
- [7] CENELEC EN 55022 (1998): "Information technology equipment - Radio disturbance characteristics - Limits and methods of measurement".

- [8] CENELEC EN 55011 (1998): "Industrial, scientific and medical (ISM) radio-frequency equipment - Radio disturbance characteristics - Limits and methods of measurement".
- [9] IEC 60489-1 + Am1 (1996) + Am2 (1999): "Methods of measurement for radio equipment used in the mobile services. Part 1: General definitions and standard conditions of measurement".
- [10] ETSI TR 100 028 (all parts): "Electromagnetic compatibility and Radio spectrum Matters (ERM); Uncertainties in the measurement of mobile radio equipment characteristics".

---

## 3 Definitions, symbols and abbreviations

### 3.1 Definitions

For the purposes of the present document, the following terms and definitions apply:

**antenna port:** port of an apparatus which is designed, in normal operation, to be connected to an antenna using coaxial cable

**broadcasting service:** radiocommunication service in which the transmissions are intended for direct reception by the general public

NOTE: This service may include sound transmissions, television transmissions or other types of transmission.

**cabinet radiation:** radiation from an enclosure containing, equipment, excluding radiation from connected antennas or cables

**carrier power:** average power supplied to the antenna port by a transmitter during one radio frequency cycle taken under the condition of no modulation

**class of emission:** set of characteristics of an emission, designated by standard symbols, e.g. type of modulation of the main carrier, modulating signal, type of information to be transmitted, and also, if appropriate, any additional signal characteristics

**dBc:** decibels relative to the unmodulated carrier power of the emission

NOTE: In the cases which do not have a carrier, for example in some digital modulation schemes where the carrier is not accessible for measurement, the reference level equivalent to dBc is decibels relative to the *mean power P*.

**digital signal:** discretely timed signal in which information is represented by a finite number of well defined discrete values that its characteristic quantities may take in time

**digital television:** television in which all information is represented by a digital signal

**enclosure port:** physical boundary of the apparatus through which electromagnetic fields may radiate or impinge

NOTE: In the case of integral antenna equipment, this port is inseparable from the antenna port.

**environmental profile:** range of environmental conditions under which equipment within the scope of EN 302 296 is required to comply with the provisions EN 302 296

**effective radiated power:** product of the power supplied to the antenna and its gain relative to a half wave dipole in a given direction

**exclusion band:** band of radio frequencies where no measurements are made

**harmonic:** component of order greater than 1 of the Fourier series of a periodic quantity

**harmonic number:** integral number given by the ratio of the frequency of a harmonic to the fundamental frequency (2<sup>nd</sup> harmonic = 2 × fundamental frequency)

**intermodulation products:** unwanted frequencies resulting from intermodulation between carriers or harmonics of emission, or between any oscillations generated to produce the carrier



**mean power:** average power supplied to the antenna port by a transmitter during an interval of time sufficiently long compared with the lowest frequency encountered in the modulation taken under normal operating conditions

**necessary bandwidth:** for a given class of emission, the width of the frequency band which is sufficient to ensure the transmission of information at the rate and with the quality required under specified conditions

**out-of-band emissions:** emission on a frequency or frequencies immediately outside the *necessary bandwidth* which results from the modulation process, but excluding *spurious emissions*

**rated output power:** power that the transmitter or transposer shall deliver at its output under specified conditions of operation

**reference bandwidth:** bandwidth in which the emission level is specified

**spurious emissions:** emission on a frequency or frequencies which are outside the *necessary bandwidth* and the level of which may be reduced without affecting the corresponding transmission of information

NOTE: Spurious emissions include harmonic emissions, parasitic emissions, intermodulation products and frequency conversion products but exclude *out-of-band emissions*.

**unwanted emissions:** consist of *spurious emissions* and *out-of-band emissions*

## 3.2 Symbols

For the purposes of the present document, the following symbols apply:

μ                      Micro

## 3.3 Abbreviations

For the purposes of the present document, the following abbreviations apply:

dB	logarithmic ratio (tenths of a "Bel")
dBm	dB relative to one milliwatt
DVB-T	Digital Video Broadcasting - Terrestrial
EMC	ElectroMagnetic Compatibility
EUT	Equipment Under Test
GHz	Giga Hertz
kHz	kilo Hertz
LV	Low Voltage
m	metres
MHz	Mega Hertz
QAM	Quadrature Amplitude Modulation
R&TTE	Radio and Telecommunications Terminal Equipment
RF	Radio Frequency
TV	TeleVision
W	Watt

---

# 4 Technical requirements specifications

## 4.1 Environmental profile

The environmental profile for operation of the equipment shall be declared by the supplier. The equipment shall comply with all the technical requirements of the present document at all times when operating within the boundary limits of the required operational environmental profile.

## 4.2 Antenna port measurements

### 4.2.1 Spurious emissions

#### 4.2.1.1 Definition

Emission on a frequency or frequencies which are outside the necessary bandwidth and the level of which may be reduced without affecting the corresponding transmission of information. Spurious emissions include harmonic emissions, parasitic emissions, intermodulation products and frequency conversion products but exclude out of band emissions.

For the purposes of the present document spurious emissions are emissions at frequencies outside the frequency range  $f_0 \pm 14$  MHz for 7 MHz channels,  $f_0 \pm 12$  MHz for 8 MHz channels, where  $f_0$  is the centre frequency of the channel, irrespective of the number of carriers employed.

#### 4.2.1.2 Method of measurement (essential test suite)

##### 4.2.1.2.1 Initial conditions

Test environment:

- the normal operating environment, as declared by the equipment manufacturer.

Test frequencies:

- 1) the lowest operating frequency of the EUT;
- 2) the highest operating frequency of the EUT;
- 3) a frequency mid-way between 1) and 2) above.

Test arrangement (see figure A.1):

- 1) connect the EUT to the test load, via the coupling device;
- 2) connect the spectrum analyser to the coupling device.

For the purposes of this test no test signal is required, the manufacturer shall ensure that the full rated output power of the transmitter will be maintained during this test.

##### 4.2.1.2.2 Procedure

- 1) operate the EUT at each of the test frequencies as defined in clause 4.2.1.2.1;
- 2) measure the results on the spectrum analyser.

##### 4.2.1.2.3 Test requirements

The results obtained shall be compared to the limits in clause 4.2.1.3 in order to demonstrate compliance.

#### 4.2.1.3 Limit

Spurious emissions shall not exceed the values set out in table 4.1 additionally shown in figures 4.1 and 4.2, for the frequency range 9 kHz to 4,5 GHz.

NOTE: In the case of a DVB-T transmitter supplied without an internal bandpass output filter, the manufacturer shall specify the characteristics of the filter necessary to fulfil the spurious emission limits defined in table 4.1. The manufacturer shall include this information in their test report.

Table 4.1: Spurious emission limits for DVB-T transmitters

Frequency range of the spurious emission	Limits of the spurious emission	Reference bandwidth	Figure
9 kHz to 174 MHz	-36 dBm (250 nW)	100 kHz	4.1
> 174 MHz to 400 MHz	-82 dBm, for $P \leq 25$ W -126 dBc, for $25$ W < $P \leq 1\ 000$ W -66 dBm, for $1\ 000$ W < $P$	4 kHz	4.2
> 400 MHz to 790 MHz	-36 dBm (250 nW)	100 kHz	4.1
> 790 MHz to 862 MHz	-76 dBm, for $P \leq 25$ W -120 dBc, for $25$ W < $P \leq 1\ 000$ W -60 dBm, for $1\ 000$ W < $P$	4 kHz	4.2
> 862 MHz to 1 000 MHz	-36 dBm (250 nW)	100 kHz	4.1
> 1 000 MHz	-30 dBm (1 $\mu$ W)	100 kHz	4.1

NOTE: P = mean power of the transmitter.

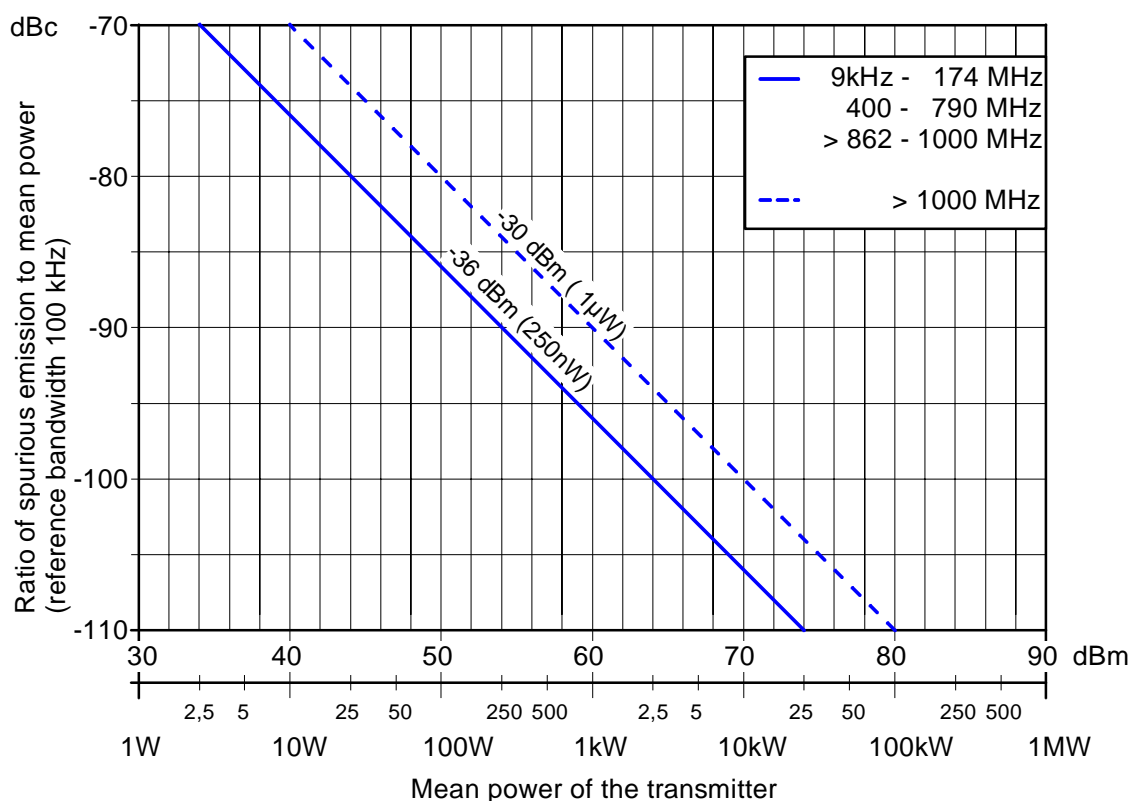
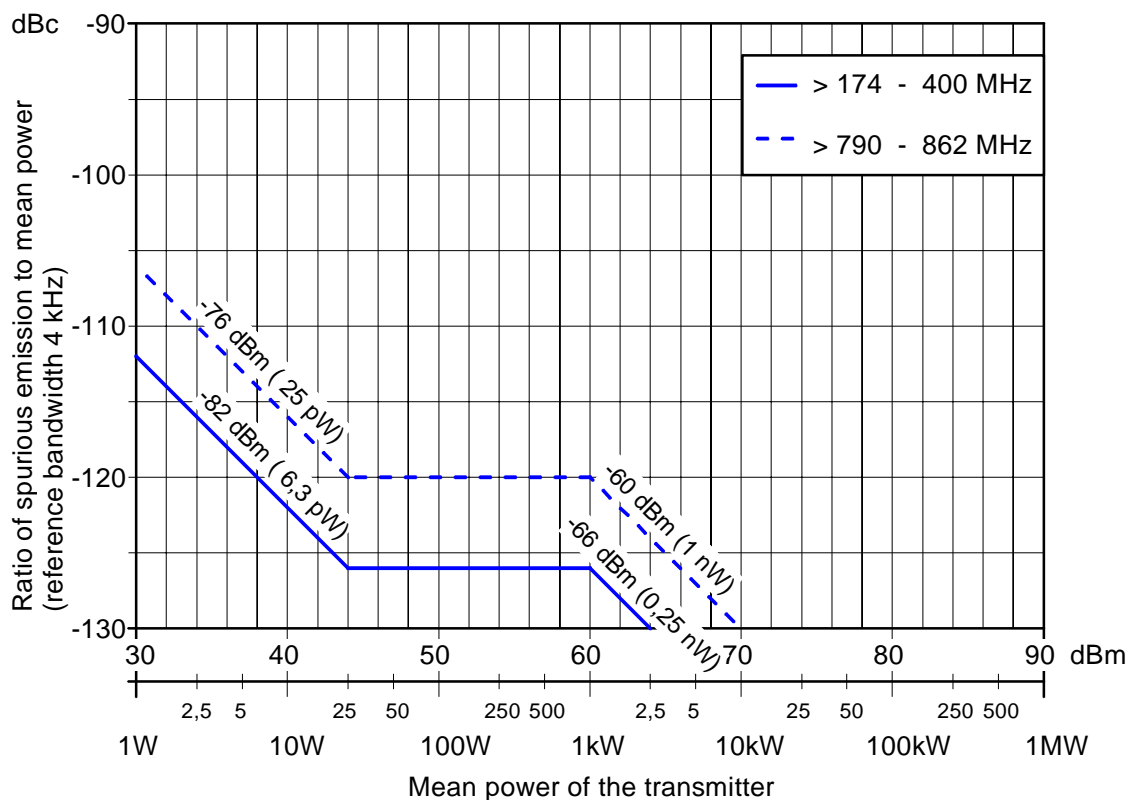

Figure 4.1: Spurious emission limits for DVB-T transmitters (100 kHz reference bandwidth)



**Figure 4.2: Spurious emission limits for DVB-T transmitters (4 kHz reference bandwidth)**

## 4.2.2 Out-of-band emissions

### 4.2.2.1 Definition

Emission on a frequency or frequencies immediately outside the necessary bandwidth which results from the modulation process, but excludes spurious emissions.

For the purposes of the present document out-of-band emissions are emissions at frequencies outside the necessary bandwidth and within the frequency ranges  $f_0 \pm 14$  MHz for 7 MHz channels,  $f_0 \pm 12$  MHz for 8 MHz channels, where  $f_0$  is the centre frequency of the channel, irrespective of the number of carriers employed.

### 4.2.2.2 Method of measurement (essential test suite)

#### 4.2.2.2.1 Initial conditions

Test environment:

- the normal operating environment, as declared by the equipment manufacturer.

Test frequencies:

- 1) the lowest operating frequency of the EUT;
- 2) the highest operating frequency of the EUT;
- 3) a frequency mid-way between 1) and 2) above.

Test arrangement (see figure A.2):

- 1) connect the EUT to the test load, via the coupling device;
- 2) connect the spectrum analyser to the coupling device.

For the purposes of this test no test signal is required, the manufacturer shall ensure that the full rated output power of the transmitter will be maintained during this test.

#### 4.2.2.2.2 Procedure

- 1) operate the EUT at each of the test frequencies as defined in clause 4.2.2.2.1;
- 2) measure the results on the spectrum analyser.

#### 4.2.2.2.3 Test requirements

The results obtained shall be compared to the limits in clause 4.2.2.3 in order to demonstrate compliance.

#### 4.2.2.3 Limit

Out-of-band emissions shall not exceed the limits specified in tables 4.2 and 4.3, additionally shown in figures 4.3 and 4.4.

Out-of-band emissions limits are given as mean power level measured in a 4 kHz bandwidth, where 0 dB corresponds to the mean output power.

Unless otherwise declared by the manufacturer it shall be assumed that the EUT conforms to the non-critical case.

For critical cases such as television channels adjacent to other services (low power or receive only) a spectrum mask with higher of out-of-channel attenuation may be needed.

NOTE: In the case of a DVB-T transmitter supplied without an internal bandpass output filter, the manufacturer shall specify the characteristics of the filter necessary to fulfil the out-of-band emission masks defined in tables 4.2 and 4.3. The manufacturer shall include this information in their test report.

**Table 4.2: Out-of-band emission limits for transmitter with output power  $\geq 25$  W**

Classification accordingly the frequency assignment	7 MHz Channel, frequency difference from the centre frequency	8 MHz Channel, frequency difference from the centre frequency	Relative level
Non-critical cases	$\pm 3,4$ MHz	$\pm 3,81$ MHz	-32,2 dBc/-32,8 dBc
	$\pm 3,7$ MHz	$\pm 4,2$ MHz	-73 dBc
	$\pm 5,25$ MHz	$\pm 6$ MHz	-85 dBc
	$\pm 10,5$ MHz	$\pm 12$ MHz	-110 dBc
	$\pm 13,85$ MHz	-	-126 dBc
Critical cases	$\pm 3,4$ MHz	$\pm 3,81$ MHz	-32,2 dBc/-32,8 dBc
	$\pm 3,7$ MHz	$\pm 4,2$ MHz	-83 dBc
	$\pm 5,25$ MHz	$\pm 6$ MHz	-95 dBc
	$\pm 10,5$ MHz	$\pm 12$ MHz	-120 dBc
	$\pm 11,75$ MHz	-	-126 dBc

Table 4.3: Out-of-band emission limits for transmitter with output power &lt; 25 W

Classification accordingly the frequency assignment	7 MHz Channel, frequency difference from the centre frequency	8 MHz Channel, frequency difference from the centre frequency	Absolute level
Non-critical cases	$\pm 3,4$ MHz	$\pm 3,81$ MHz	11,8 dBm/11,2 dBm
	$\pm 3,7$ MHz	$\pm 4,2$ MHz	-29 dBm
	$\pm 5,25$ MHz	$\pm 6$ MHz	-41 dBm
	$\pm 10,5$ MHz	$\pm 12$ MHz	-66 dBm
	$\pm 13,85$ MHz	-	-82 dBm
Critical cases	$\pm 3,4$ MHz	$\pm 3,9$ MHz	11,8 dBm/11,2 dBm
	$\pm 3,7$ MHz	$\pm 4,2$ MHz	-39 dBm
	$\pm 5,25$ MHz	$\pm 6$ MHz	-51 dBm
	$\pm 10,5$ MHz	$\pm 12$ MHz	-76 dBm
	$\pm 11,75$ MHz	-	-82 dBm

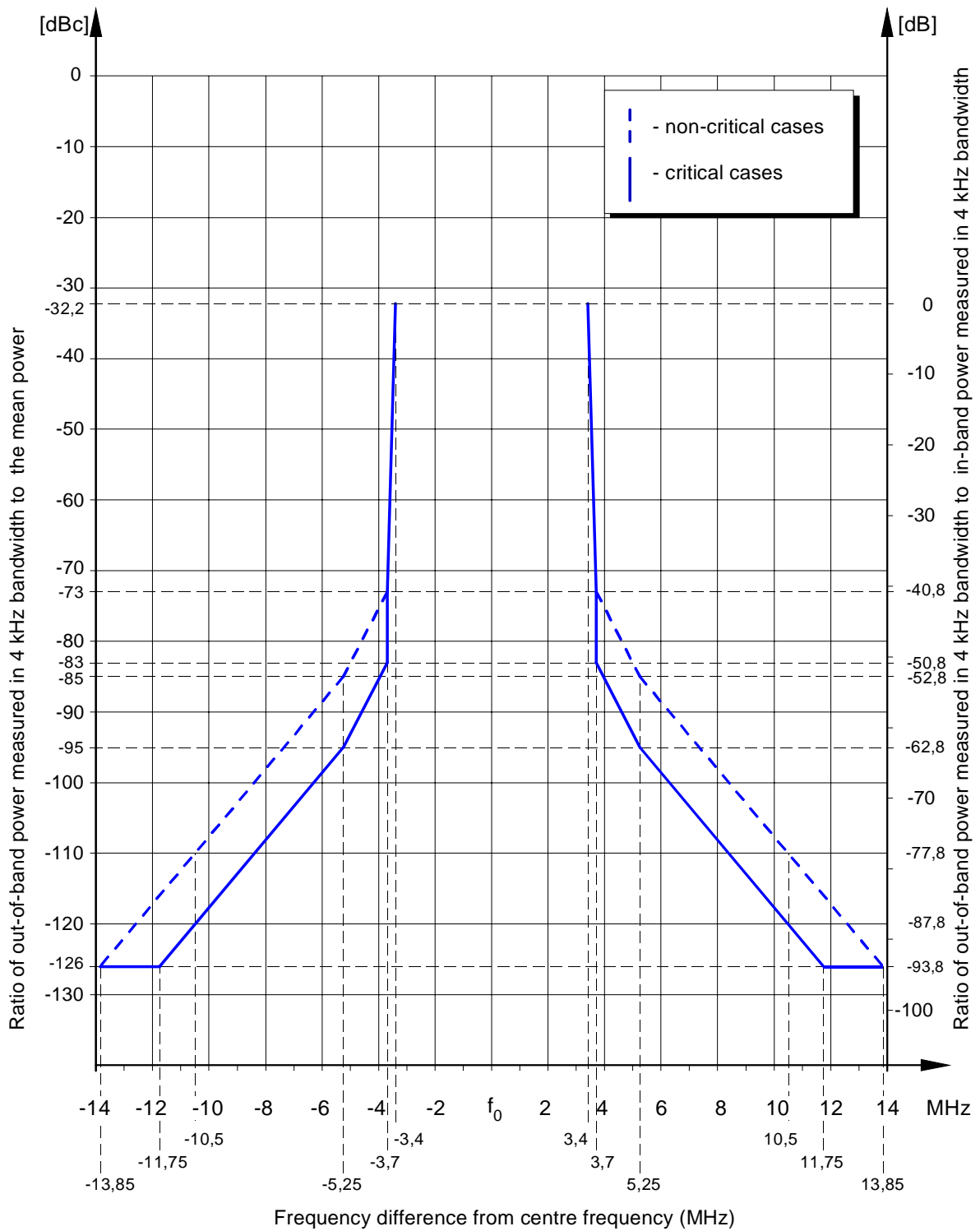

Figure 4.3: Out-of-band limits for DVB-T transmitters  $\geq 25$  W in 7 MHz channels

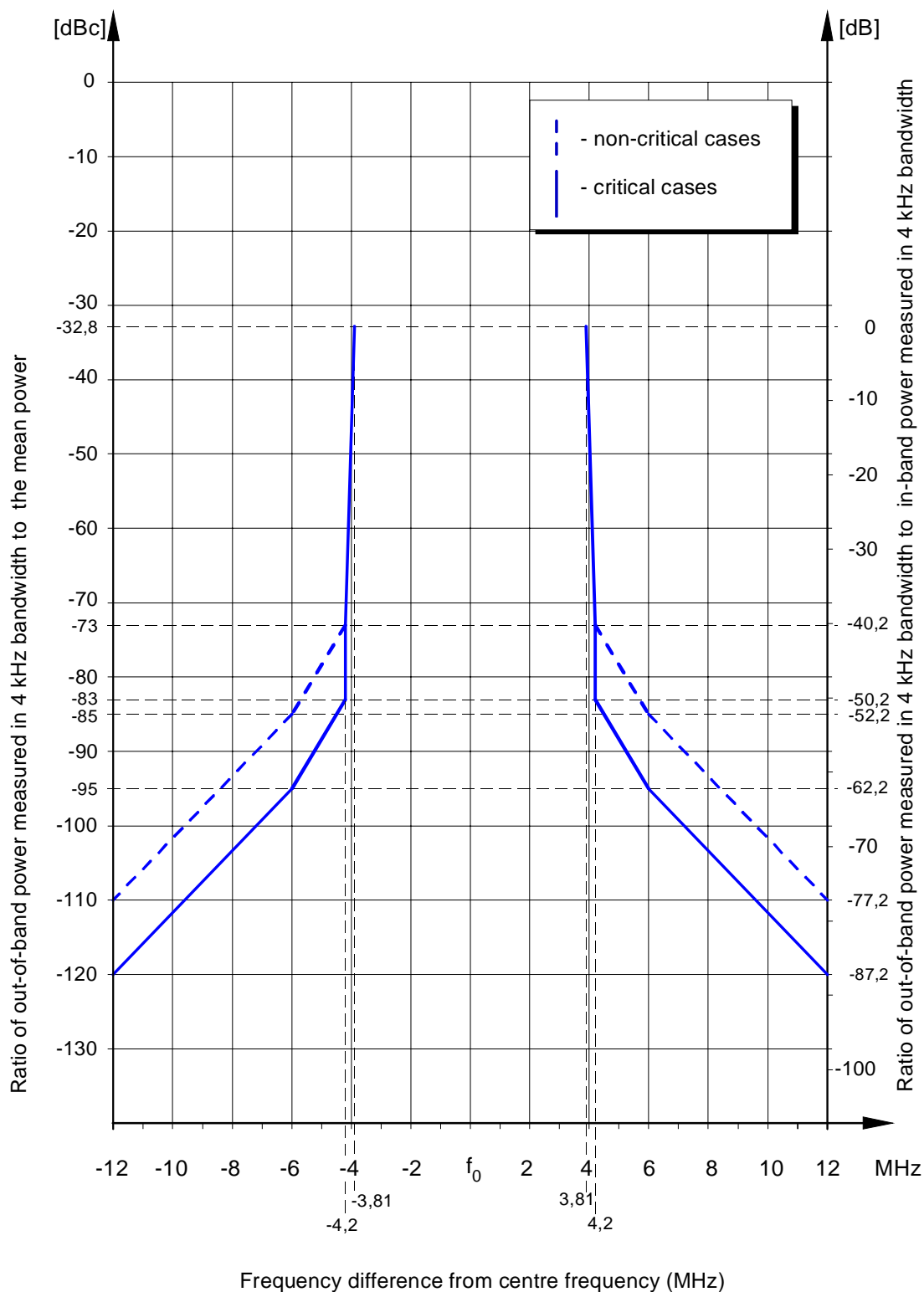

Figure 4.4: Out-of-band limits for DVB-T transmitters  $\geq 25$  W in 8 MHz channels



## 4.3 Enclosure port measurements (radiated emissions)

### 4.3.1 Cabinet radiation

#### 4.3.1.1 Definition

Emissions from the equipment, radiated from the enclosure port, other than those present at the antenna port.

#### 4.3.1.2 Method of test (essential test suite)

##### 4.3.1.2.1 Initial conditions

Test environment:

- the normal operating environment, as declared by the equipment manufacturer.

Test frequencies:

- 1) the lowest operating frequency of the EUT;
- 2) the highest operating frequency of the EUT;
- 3) a frequency mid-way between 1) and 2) above.

Test arrangement: (see figure A.3):

For the purposes of this test no test signal is required, the manufacturer shall ensure that the full rated output power of the transmitter will be maintained during this test.

##### 4.3.1.2.2 Procedure

The test method shall be in accordance with EN 55022 [7], unless physical size is a restriction, in which case the test method shall be in accordance with EN 55011 [8]:

- measurements shall be made outside the exclusion band (see table 4.4);
- measurements shall be made in the operational mode producing the largest emission in the frequency band being investigated consistent with normal applications;
- the equipment shall be configured in a manner which is representative of a normal/typical operation, where practical;
- an attempt shall be made to maximize the detected radiated emission, e.g. by moving the cables of the equipment;
- the configuration and mode of operation during measurements shall be precisely noted in the test report;
- RF input/output ports shall be correctly terminated;
- the tests shall be carried out at a point within the specified normal operating environmental range and at the rated supply voltage for the equipment.

##### 4.3.1.2.3 Test requirements

The results obtained shall be compared to the limits in clause 4.3.1.3 in order to demonstrate compliance.

### 4.3.1.3 Limits

Radiated emissions shall not exceed the values set out in table 4.4, shown additionally in figure 4.5, for the frequency range 30 MHz to 4,5 GHz.

This test shall be performed at a distance of 10 m, where feasible. When size and/or power requirements necessitate testing in a manufacturing facility, other distances may be used (see notes 1, 2 and 3). Tests shall not be carried out in the exclusion band (see note 2 in table 4.4).

**Table 4.4: Cabinet radiation limits**

Quasi-peak limits (dB $\mu$ V/m) at 10 m (see notes 1 and 2)	Frequency range
$30 \text{ dB}\mu\text{V/m} \leq 60 + 10 \log_{10} (P_0/2\,000) \leq 70 \text{ dB}\mu\text{V/m}$	30 MHz to 230 MHz
$37 \text{ dB}\mu\text{V/m} \leq 67 + 10 \log_{10} (P_0/2\,000) \leq 77 \text{ dB}\mu\text{V/m}$	> 230 MHz to 4,5 GHz
NOTE 1: $P_0$ = RF output power in W.	
NOTE 2: The exclusion band for the transmitter shall be the allocated channel.	

NOTE 1: The measurements can be carried out at other distances. In that case limits are modified according to the relation:

$$L(x) = L(10\text{m}) + 20 \log (10/x) \quad \text{where } x = \text{distance in meter (m)}.$$

NOTE 2: Care should be taken if measuring at test distances below 10 m as this may be in the near field.

NOTE 3: In cases of dispute the measurement distance of 10 m shall take precedence.

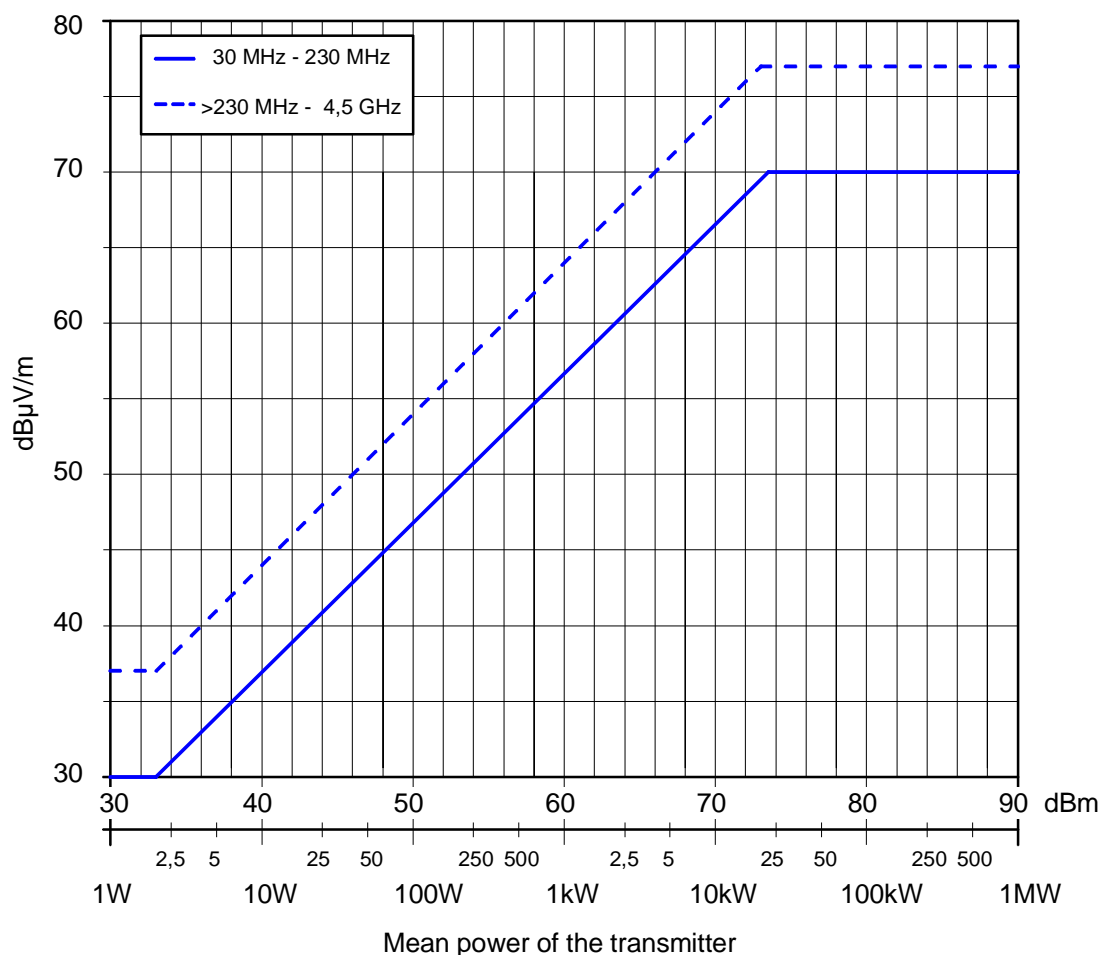

**Figure 4.5: Cabinet radiation limits for DVB-T transmitters**

## 4.4 Measurement uncertainties

Measurement uncertainty should be calculated and techniques employed to minimize its range. This uncertainty should be applied to the limit and any measurement falling below the range is deemed acceptable (TR 100 028 [10]).

## Annex A (normative): General measuring arrangements

### A.1 Testing arrangements for antenna port measurements

#### A.1.1 Spurious emissions

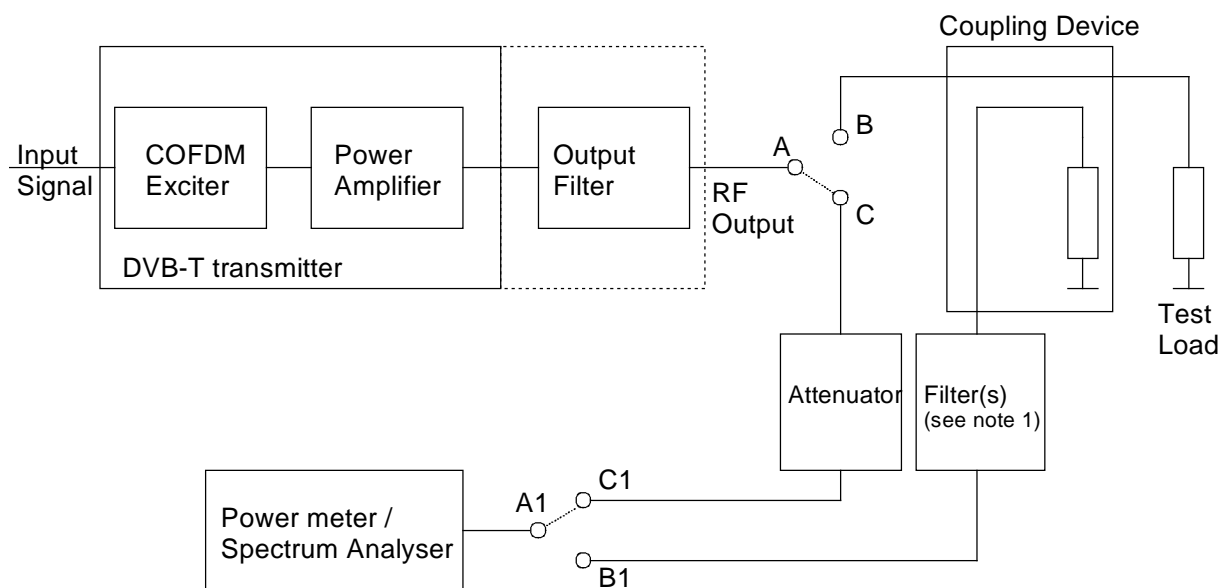

NOTE 1: The optional filter should suppress the output signal so that no intermodulation products are generated by the spectrum analyser. The insertion loss throughout the measuring range should be known.

NOTE 2: For high power transmitters the preferred set up would require A to be connected to B and A1 to be connected to B1.

NOTE 3: For low power transmitters the preferred set up would require A to be connected to C and A1 to be connected to C1.

NOTE 4: If the transmitter does not include any output filter, an external filter shall be added after the transmitter for the testing arrangement. This filter shall be representative of the multiplexer or filter existing in operational conditions and viewed by the transmitted output when installed. In this case, the antenna port measurements shall be performed at the output of this extra filter.

**Figure A.1: Testing arrangement for spurious emissions**

## A.1.2 Out-of-band emissions

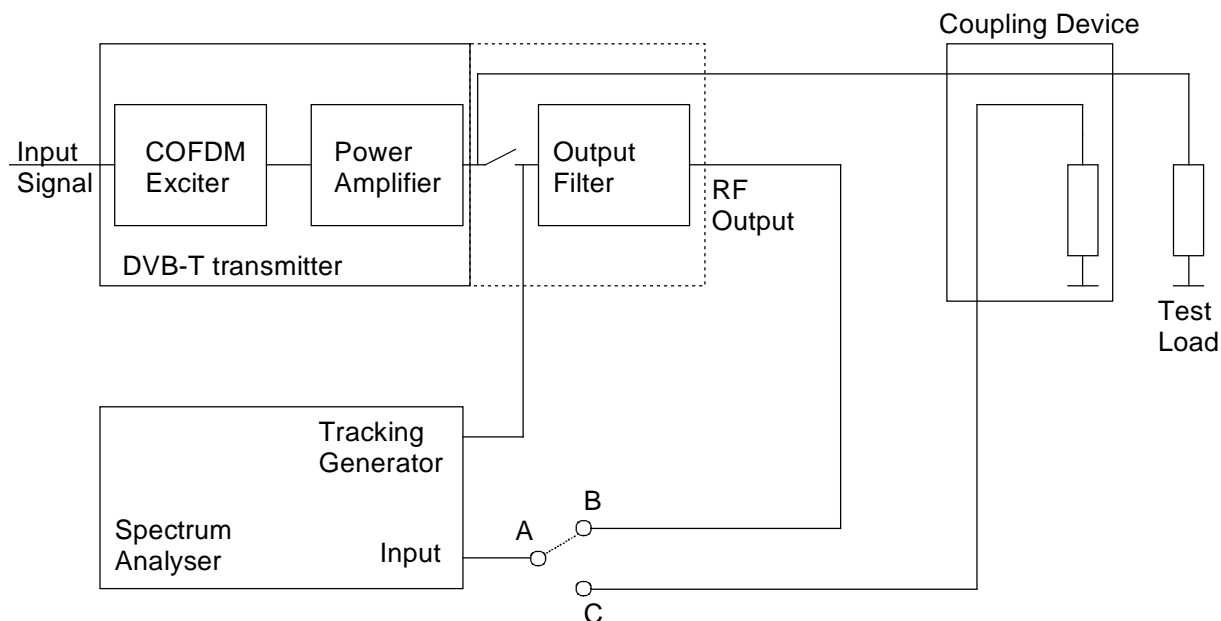

NOTE 1: Disconnect the power amplifier from the output filter.

NOTE 2: The frequency response of the output filter must be measured and recorded (Connection A-B).

NOTE 3: The spectrum of the DVB-T signal at the output of the power amplifier must be measured and recorded (Connection A-C).

NOTE 4: The out-of-band spectrum of the DVB-T signal shall be calculated by applying the recorded frequency response of the output filter to the recorded spectrum of the DVB-T signal.

NOTE 5: If the transmitter does not include any output filter, an external filter shall be added after the transmitter for the testing arrangement. This filter shall be representative of the multiplexer or filter existing in operational conditions and viewed by the transmitted output when installed. In this case, the antenna port measurements shall be performed at the output of this extra filter.

**Figure A.2: Testing arrangement for out-of-band emissions**

## A.1.3 Test frequency range

Limits on unwanted emissions for radio equipments are considered to be applicable to the range 9 kHz to 300 GHz. However, for practical measurement purposes, the frequency range of spurious emissions may be restricted. As guidance for practical purposes, the following measurement parameters in table A.1 are recommended.

**Table A.1: Test frequency range**

Transmitter fundamental frequency range	Unwanted emission frequency measurement range	
	lower frequency	upper frequency
47 MHz to 862 MHz	9 kHz	4,5 GHz

The following reference bandwidths are to be used:

For spurious emissions:

- 100 kHz between 9 kHz and 174 MHz;
- 4 kHz between 174 MHz and 400 MHz;
- 100 kHz between 400 MHz and 790 MHz;
- 4 kHz between 790 MHz and 862 MHz;

- 100 kHz between 862 MHz and 1 000 MHz;
- 100 kHz above 1 000 MHz.

For out-of-band emissions:

- 4 kHz.

### A.1.4 Test modulating signal

The modulation signal at the input of the transmitter shall be as stated in EN 300 744 [6], clause 4.3, but with the following specific settings:

- Mode 8 K.
- Guard interval duration 1/32.
- TS modulation 64 QAM.
- Code Ratio 2/3.

---

## A.2 Testing arrangements for enclosure port (radiated emissions) measurements

Further guidance can be found in IEC 60489-1 amendment 2 [9].

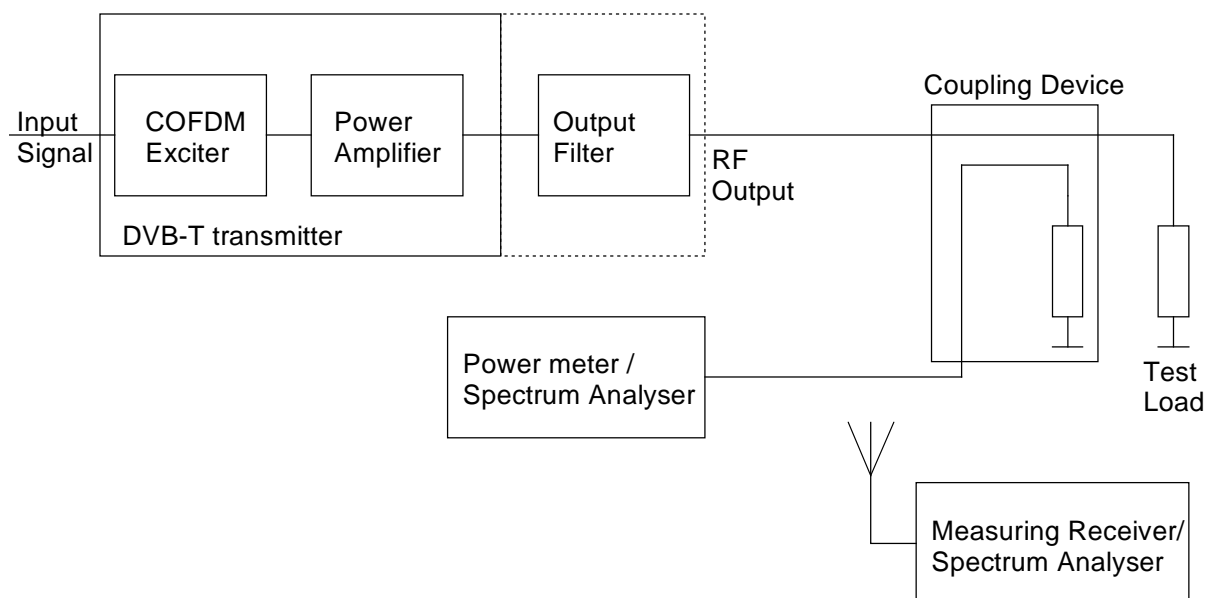

NOTE: If the transmitter does not include any output filter, an external filter shall be added after the transmitter for the testing arrangement. This filter shall be representative of the multiplexer or filter existing in operational conditions and viewed by the transmitted output when installed.

**Figure A.3: Testing arrangement for cabinet radiation**

---

## Annex B (informative): Bibliography

- The Chester 1997 Multilateral Co-ordination Agreement Relating to Technical Criteria, Co-ordination Principles and Procedures for the Introduction of Terrestrial Digital Video Broadcasting (DVB-T) Chester, 25<sup>th</sup> July 1997 Resolution 5.
- CEPT/ERC Recommendation 74-01: "Spurious emissions".
- ITU-R Recommendation SM.329-10: "Unwanted emissions in the spurious domain".
- ITU-R Recommendation SM.328-10: "Spectra and bandwidth of emissions".
- ITU-R Recommendation SM.1541-1: "Unwanted emissions in the out-of-band domain".
- ETSI ETR 290: "Digital Video Broadcasting (DVB); Measurement guidelines for DVB systems".
- IEC 60244-1: "Methods of measurement for radio transmitters - Part 1: General characteristics for broadcast transmitters".
- IEC 60244-6: "Methods of measurement for radio transmitters - Part 6: Cabinet radiation at frequencies between 130 kHz and 1 GHz".
- IEC 61000-4-3/Am1 (2002): "Electromagnetic compatibility (EMC) - Part 4-3: Testing and measurement techniques - Radiated, radio-frequency, electromagnetic field immunity test".
- ETSI TR 101 190: "Digital Video Broadcasting (DVB); Implementation guidelines for DVB terrestrial services; Transmission aspects".

## Annex C (informative): The EN title in the official languages

Language	EN title
Czech	
Danish	
Dutch	
English	Electromagnetic compatibility and Radio spectrum Matters (ERM); Transmitting equipment for the digital television broadcast service, Terrestrial (DVB-T); Harmonized EN under article 3.2 of the R&TTE Directive.
Estonian	
Finnish	
French	CEM et spectre radioélectrique (ERM); Équipements de transmission pour la diffusion du service de télévision numérique terrestre (DVB-T); EN harmonisée couvrant l'article 3.2 de la Directive R&TTE
German	Elektromagnetische Verträglichkeit und Funkspektrumangelegenheiten (ERM); Sendertechnische Einrichtungen für den terrestrischen digitalen Fernseh-Rundfunkdienst (DVB-T); Harmonisierte EN nach Artikel 3.2 der R&TTE Richtlinie
Greek	
Hungarian	
Icelandic	
Italian	
Latvian	
Lithuanian	
Maltese	
Polish	Kompatybilność Elektromagnetyczna i Zagadnienia Widma Radiowego (ERM) - Urządzenia nadawcze cyfrowej telewizyjnej służby radiodfuzyjnej, naziemna (DVB-T) - Zharmonizowana EN zgodna z artykułem 3.2 dyrektywy R&TTE
Portuguese	
Slovak	
Slovenian	
Spanish	
Swedish	

---

## History

<b>Document history</b>				
V1.1.1	April 2004	Public Enquiry	PE 20040813:	2004-04-14 to 2004-08-13
V1.1.1	November 2004	Vote	V 20050121:	2004-11-22 to 2005-01-21