

ETSI EN 302 288-1 V1.3.1 (2008-02)

European Standard (Telecommunications series)

**Electromagnetic compatibility
and Radio spectrum Matters (ERM);
Short Range Devices;
Road Transport and Traffic Telematics (RTTT);
Short range radar equipment operating in the 24 GHz range;
Part 1: Technical requirements and
methods of measurement**



Reference

REN/ERM-TG31B-004-1

Keywords

radar, radio, RTTT, SRD, testing

ETSI

650 Route des Lucioles
F-06921 Sophia Antipolis Cedex - FRANCE

Tel.: +33 4 92 94 42 00 Fax: +33 4 93 65 47 16

Siret N° 348 623 562 00017 - NAF 742 C
Association à but non lucratif enregistrée à la
Sous-Préfecture de Grasse (06) N° 7803/88

Important notice

Individual copies of the present document can be downloaded from:

<http://www.etsi.org>

The present document may be made available in more than one electronic version or in print. In any case of existing or perceived difference in contents between such versions, the reference version is the Portable Document Format (PDF). In case of dispute, the reference shall be the printing on ETSI printers of the PDF version kept on a specific network drive within ETSI Secretariat.

Users of the present document should be aware that the document may be subject to revision or change of status. Information on the current status of this and other ETSI documents is available at

<http://portal.etsi.org/tb/status/status.asp>

If you find errors in the present document, please send your comment to one of the following services:

http://portal.etsi.org/chaicor/ETSI_support.asp

Copyright Notification

No part may be reproduced except as authorized by written permission.
The copyright and the foregoing restriction extend to reproduction in all media.

© European Telecommunications Standards Institute 2008.
All rights reserved.

DECTTM, **PLUGTESTS**TM and **UMTS**TM are Trade Marks of ETSI registered for the benefit of its Members.
TIPHONTM and the **TIPHON logo** are Trade Marks currently being registered by ETSI for the benefit of its Members.
3GPPTM is a Trade Mark of ETSI registered for the benefit of its Members and of the 3GPP Organizational Partners.

Contents

Intellectual Property Rights	6
Foreword.....	6
1 Scope	7
2 References	7
3 Definitions, symbols and abbreviations	8
3.1 Definitions	8
3.2 Symbols.....	10
3.3 Abbreviations	10
4 Technical requirements specifications	11
4.1 Presentation of equipment for testing purposes.....	11
4.1.1 Choice of model for testing	11
4.2 Mechanical and electrical design.....	11
4.3 Auxiliary test equipment	12
4.4 Interpretation of the measurement results	12
5 Test conditions, power sources and ambient temperatures	12
5.1 Normal and extreme test conditions	12
5.2 External test power source.....	12
5.3 Normal test conditions.....	12
5.3.1 Normal temperature and humidity	12
5.3.2 Normal test power source	13
5.3.2.1 Mains voltage	13
5.3.2.2 Other power sources.....	13
5.4 Extreme test conditions	13
5.4.1 Extreme temperatures	13
5.4.1.1 Procedure for tests at extreme temperatures.....	13
5.4.1.2 Extreme temperature ranges.....	13
5.4.2 Extreme test source voltages.....	13
5.4.2.1 Mains voltage	13
5.4.2.2 Other power sources.....	13
6 General conditions.....	14
6.1 Test fixture	14
6.1.1 Requirements	14
6.1.2 Calibration	15
6.1.3 General requirements for RF cables.....	16
6.1.4 Shielded anechoic chamber.....	17
7 Methods of measurement and limits for transmitter parameters	18
7.1 Methods of measurement and limits for transmitters in the 22,000 GHz to 26,65 GHz band.....	18
7.1.1 Permitted range of operating frequencies	18
7.1.1.1 Definition	18
7.1.1.2 Method of measurement.....	18
7.1.1.3 Limits	19
7.1.2 Maximum radiated average power density (e.i.r.p.)	19
7.1.2.1 Definition	19
7.1.2.2 Method of measurement.....	19
7.1.2.3 Limits	21
7.1.3 Maximum radiated peak power density (e.i.r.p.)	21
7.1.3.1 Definition	21
7.1.3.2 Method of measurement.....	21
7.1.3.3 Standard procedure and setup extensions.....	22
7.1.3.4 Limits	22
7.1.4 Methods of measurement and limits for emissions in the 24,05 GHz to 24,25 GHz band	23
7.1.4.1 Equivalent isotropically radiated power (e.i.r.p.).....	23

7.1.4.1.1	Definition.....	23
7.1.4.1.2	Method of measurement	23
7.1.4.1.3	Limits	25
7.1.4.2	Permitted range of operating frequencies.....	25
7.1.4.2.1	Definition.....	25
7.1.4.2.2	Method of measurement for equipment not using FH modulation.....	25
7.1.4.2.3	Method of measurement for equipment using pulsed FH modulation.....	26
7.1.4.2.4	Limit	26
7.1.5	Vertical plane transmitter emissions in the 23,6 GHz to 24 GHz range	27
7.1.5.1	Definition	27
7.1.5.2	Measurement procedure	27
7.1.5.3	Vertical emission limits in the 23,6 GHz to 24,0 GHz range.....	27
7.2	Radiated spurious and out-of-band emissions	27
7.2.1	Definition.....	27
7.2.2	Measuring receiver	28
7.2.3	Method of measurement for radiated spurious or out-of-band emissions.....	28
7.2.4	Limits.....	29
8	Methods of measurement and limits for receiver parameters.....	29
8.1	Receiver spurious emissions.....	29
8.1.1	Definition.....	29
8.1.2	Method of measurement - radiated spurious emissions	29
8.1.3	Limit	30
9	Measurement uncertainty	30
Annex A (normative): Radiated measurements		31
A.1	Test sites and general arrangements for measurements involving the use of radiated fields.....	31
A.2	Guidance on the use of radiation test sites	31
A.2.1	Substitution antenna	31
A.3	Indoor test site using a fully anechoic RF chamber	31
A.3.1	Example of the construction of a shielded anechoic chamber	31
A.3.2	Influence of parasitic reflections in anechoic chambers.....	33
A.3.3	Calibration of the shielded RF anechoic chamber.....	33
Annex B (normative): General description of measurement methods.....		34
B.1	Radiated measurements.....	34
B.2	Performance requirements for preamplifier and horn antenna.....	35
B.3	Measurement of the residual carrier	35
Annex C (informative): Example of modulation schemes.....		36
C.1	Pseudo Noise Pulse Position Modulation (PN PPM).....	36
C.1.1	Definition	36
C.1.2	Typical operation parameters	37
C.2	Pulsed FH (Pulsed Frequency Hopping)	37
C.2.1	Definition	37
C.2.2	Typical operation parameters	38
C.2.3	Additional requirements for pulsed FH equipment measurement	38
C.2.3.1	Pulsed FH modulation	38
C.2.3.2	Measurement requirements.....	38
C.3	PN-2-PSK (Pseudo noise binary coded phase shift keying).....	39
C.3.1	Definition	39
C.3.2	Typical operation parameters	40
Annex D (normative): Installation requirements of 24 GHz Short Range Radar (SRR) systems		41

Annex E (informative):	Conversion of power density to e.i.r.p.....	42
E.1	Assumptions	42
E.2	Example.....	42
Annex F (informative):	Bibliography.....	43
History		44

Intellectual Property Rights

IPRs essential or potentially essential to the present document may have been declared to ETSI. The information pertaining to these essential IPRs, if any, is publicly available for **ETSI members and non-members**, and can be found in ETSI SR 000 314: "*Intellectual Property Rights (IPRs); Essential, or potentially Essential, IPRs notified to ETSI in respect of ETSI standards*", which is available from the ETSI Secretariat. Latest updates are available on the ETSI Web server (<http://webapp.etsi.org/IPR/home.asp>).

Pursuant to the ETSI IPR Policy, no investigation, including IPR searches, has been carried out by ETSI. No guarantee can be given as to the existence of other IPRs not referenced in ETSI SR 000 314 (or the updates on the ETSI Web server) which are, or may be, or may become, essential to the present document.

Foreword

This European Standard (Telecommunications series) has been produced by ETSI Technical Committee Electromagnetic compatibility and Radio spectrum Matters (ERM).

For non EU countries the present document may be used for regulatory (Type Approval) purposes.

Equipment compliant with the present document is intended for fitment into road vehicles, therefore it is subject to automotive EMC type approval and has to comply with Directive 95/54/EC [7]. For use on vehicles outside the scope of Directive 95/54/EC [7] compliance with an EMC directive/standard appropriate for that use is required.

The present document is part 1 of a multi-part deliverable covering Electromagnetic compatibility and Radio spectrum Matters (ERM); Short Range Devices, Road Transport and Traffic Telematics (RTTT); Short range radar equipment operating in the 24 GHz range, as identified below:

Part 1: "Technical requirements and methods of measurement";

Part 2: "Harmonized EN covering essential requirements of article 3.2 of the R&TTE Directive".

National transposition dates	
Date of adoption of this EN:	10 August 2007
Date of latest announcement of this EN (doa):	30 November 2007
Date of latest publication of new National Standard or endorsement of this EN (dop/e):	31 May 2008
Date of withdrawal of any conflicting National Standard (dow):	31 May 2008

1 Scope

The present document specifies the technical requirements and methods of measurement for Short Range Devices (SRD) working as broadband devices with at least 500 MHz bandwidth in the 22,000 GHz to 26,65 GHz frequency range intended for Road Transport and Traffic Telematics (RTTT) applications, such as automotive 24 GHz Short Range Radar (SRR) for e.g. obstacle detection, stop and go, blind spot detection, parking aid, backup aid, precrash and other automotive applications.

The present document covers transmitters intended to operate in a temporary frequency designation under the 24 GHz ECC decision CEPT/ECC/DEC/(04)10. The application is also subject to the EU Commission decision on 24 GHz SRR 2005/50/EC.

The present document applies to:

- a) Transmitters in the range from 22,000 GHz to 26,65 GHz operating as broadband devices over the specific bandwidth defined for the individual devices.
- b) Receivers operating in the range from 22,000 GHz to 26,65 GHz.
- c) Integrated transceivers.

The present document contains the technical characteristics and test methods for short range radar equipment fitted with integral antennas.

The present document does not necessarily include all the characteristics which may be required by a user, nor does it necessarily represent the optimum performance achievable.

The present document covers short range radar mobile applications. The present document covers only SRR equipment for road vehicles.

The present document complies with field limits for human exposure to electromagnetic fields as provided by the EC Recommendation 1999/519/EC (see bibliography) and the methods for compliance demonstration in EN 50371 (see bibliography).

2 References

The following documents contain provisions which, through reference in this text, constitute provisions of the present document.

- References are either specific (identified by date of publication and/or edition number or version number) or non-specific.
- For a specific reference, subsequent revisions do not apply.
- For a non-specific reference, the latest version applies.

Referenced documents which are not found to be publicly available in the expected location might be found at <http://docbox.etsi.org/Reference>.

NOTE: While any hyperlinks included in this clause were valid at the time of publication ETSI cannot guarantee their long term validity.

- [1] Void.
- [2] CISPR 16 (parts 1-1, 1-4 and 1-5): "Specification for radio disturbance and immunity measuring apparatus and methods; Part 1: Radio disturbance and immunity measuring apparatus".
- [3] CEPT/ERC/REC 01-06: "Procedure for mutual recognition of type testing and type approval for radio equipment".
- [4] Void.

- [5] Void.
- [6] ETSI TR 100 028 (V1.4.1) (all parts): "Electromagnetic compatibility and Radio spectrum Matters (ERM); Uncertainties in the measurement of mobile radio equipment characteristics".
- [7] Commission Directive 95/54/EC of 31 October 1995 adapting to technical progress Council Directive 72/245/EEC on the approximation of the laws of the Member States relating to the suppression of radio interference produced by spark-ignition engines fitted to motor vehicles and amending Directive 70/156/EEC on the approximation of the laws of the Member States relating to the type-approval of motor vehicles and their trailers.
- [8] ETSI EN 302 288-2 (V1.2.2): "Electromagnetic compatibility and Radio spectrum Matters (ERM); Short Range Devices; Road Transport and Traffic Telematics (RTTT); Short range radar equipment operating in the 24 GHz range; Part 2: Harmonized EN covering the essential requirements of article 3.2 of the R&TTE Directive".
- [9] Void.
- [10] Void.
- [11] Void.
- [12] Void.

3 Definitions, symbols and abbreviations

3.1 Definitions

For the purposes of the present document, the following terms and definitions apply:

activity factor: actual on-the-air time divided by active session time or actual on-the-air emission time within a given time window

antenna scan duty factor: ratio of the area of the beam (measured at its -3 dB point) to the total area scanned by the antenna (as measured at its -3 dB point)

assigned frequency band: frequency band within which the device is authorized to operate

associated antenna: antenna and all its associated components which are designed as an indispensable part of the equipment

average time: time interval on which a mean measurement is integrated

blanking period: time period where either no waveform or a constant waveform within the 24 GHz SRD band occurs

boresight: axis of the main beam in a directional antenna

channel dwell duty cycle: ratio of the time of uninterrupted continuous transmission within a given frequency channel to the channel repetition interval

NOTE: Channel dwell time/channel repetition interval.

channel dwell time: accumulated amount of transmission time of uninterrupted continuous transmission within a single given frequency channel and within one channel repetition interval

duty cycle: the ratio of the total on time of the "message" to the total off-time in any one hour period

NOTE: The device may be triggered either automatically or manually, whether the duty cycle is fixed or random depends on how the device is triggered.

Equipment Under Test (EUT): radar sensor including the integrated antenna together with any external antenna components which affect or influence its performance

equivalent isotropically radiated power (e.i.r.p.): total power or power density transmitted, assuming an isotropic radiator

NOTE: e.i.r.p. is conventionally the product of "power or power density into the antenna" and "antenna gain".
e.i.r.p. is used for both peak or average power and peak or average power density.

equivalent pulse power duration: duration of an ideal rectangular pulse which has the same content of energy compared with the pulse shape of the EUT with pulsed modulation or on-off gating

far field measurements: measurement at a distance "X" of at least $2d^2/\lambda$, where d is the largest dimension of the antenna aperture of the EUT

maximum safe level for radiated power density: level which can be transmitted in accordance with the current recommended safety levels in Council Recommendation 1999/519/EC

on-off gating: methods of transmission with fixed or randomly quiescent period that is much larger than the PRF

operating frequency (operating centre frequency): nominal frequency at which equipment is operated

NOTE: Equipment may be able to operate at more than one operating frequency.

operating frequency range: range of operating frequencies over which the equipment can be adjusted through switching or reprogramming or oscillator tuning

NOTE 1: For pulsed or phase shifting systems without further carrier tuning the operating frequency range is fixed on a single carrier line.

NOTE 2: For analogue or discrete frequency modulated systems (FSK, FMCW) the operating frequency range covers the difference between minimum and maximum of all carrier frequencies on which the equipment can be adjusted.

power envelope: power supplied to the antenna by a transmitter during one radio frequency cycle at the crest of the modulation envelope taken under normal operating conditions

Power Spectral Density (PSD): ratio of the amount of power to the used radio measurement bandwidth

NOTE: It is expressed in units of dBm/Hz or as a power in unit dBm with respect to the used bandwidth. In case of measurement with a spectrum analyser the measurement bandwidth is equal to the RBW.

precrash: time before the crash occurs when safety mechanism are deployed

Pulse Repetition Frequency (PRF): inverse of the Pulse Repetition Interval, averaged over a time sufficiently long as to cover all PRI variations

Pulse Repetition Interval (PRI): time between the rising edges of the transmitted (pulsed) output power

quiescent period: time instant where no intentional emission occurs

radome: external protective cover which is independent of the associated antenna, and which may contribute to the overall performance of the antenna (and hence, the EUT)

spatial radiated power density: power per unit area normal to the direction of the electromagnetic wave propagation

NOTE: Spatial radiated power density is expressed in units of W/m².

spread spectrum: telecommunications techniques in which a [signal](#) is transmitted in a [bandwidth](#) considerably greater than the [frequency](#) content of the original [information](#)

ultra wideband: classification of the spectral width of a transmission system

ultra-wideband bandwidth: equipment using ultra-wideband technology means equipment incorporating, as an integral part or as an accessory, technology for short-range radiocommunication, involving the intentional generation and transmission of radio-frequency energy that spreads over a frequency range wider than 50 MHz

3.2 Symbols

For the purposes of the present document, the following symbols apply:

λ	Wavelength
ac	alternating current
B	Bandwidth
B_{FH}	Frequency hopping bandwidth
d	largest dimension of the antenna aperture
D_{fb}	distance of ferrite beads
E	Field strength
E_o	Reference field strength
f_c	Carrier frequency
f_{hop}	Hopping frequency
f_h	highest frequency
f_l	lowest frequency
G_a	Antenna gain
P_{rad}	Radiated power
$P_{PK\ 3\ MHz}$	Radiated peak power measured in 3 MHz bandwidth
P_s	Signal generator power
R	Distance
R_o	Reference distance
Rx	Receiver
τ	Pulse width
T_{blk}	Blank time period
T_c	Chip period
T_{dw}	Dwell time
T_{fr}	Frame time
T_{pw}	Pulse power duration
Tx	Transmitter

3.3 Abbreviations

For the purposes of the present document, the following abbreviations apply:

BPSK	Binary Phase Shift Keying
CW	Continuous Wave
dB	decibel
dB _i	gain in decibels relative to an isotropic antenna
DSB	Dual Side Band
DSS	Direct Sequence Signal
e.i.r.p.	equivalent isotropically radiated power
ECC	Electronic Communications Committee
EMC	Electro Magnetic Compatibility
ERC	European Radiocommunication Committee
EUT	Equipment Under Test
FH	Frequency Hopping
FHSS	Frequency Hopping Spread Spectrum
FMCW	Frequency Modulated Continuous Wave
FSK	Frequency Shift Keying
IF	Intermediate Frequency
LNA	Low Noise Amplifier
PDCF	Pulse Desensitization Correction Factor
PM	Pulse Modulation
PN	Pseudo Noise
PPM	Pulse Position Modulation (staggered)
PRF	Pulse Repetition Frequency

PRI	Pulse Repetition Interval
PSK	Phase Shift Keying
R&TTE	Radio and Telecommunications Terminal Equipment
RAS	Radio Astronomy Site
RBW	Resolution BandWidth
RF	Radio Frequency
RMS	Root Mean Square
RTTT	Road Transport and Traffic Telematics
Rx	Receiver (Receive)
SA	Spectrum Analyser
SNR	Signal to Noise Ratio
SPM	Staggered Pulse Position Modulated
SRD	Short Range Device
SRR	Short Range Radar
Tx	Transmitter
VBW	Video BandWidth
VSWR	Voltage Standing Wave Ratio

4 Technical requirements specifications

4.1 Presentation of equipment for testing purposes

Each equipment submitted for testing, where applicable, shall fulfil the requirements of the present document on all frequencies over which it is intended to operate. EMC type approval testing to Directive 95/54/EC [7] shall be done on the vehicle.

The provider shall provide one or more samples of the equipment, as appropriate for testing.

Additionally, technical documentation and operating manuals, sufficient to allow testing to be performed, shall be supplied.

The performance of the equipment submitted for testing shall be representative of the performance of the corresponding production model. In order to avoid any ambiguity in that assessment, the present document contains instructions for the presentation of equipment for testing purposes, conditions of testing (clause 5) and the measurement methods (clauses 7 and 8). Instructions for installation of the equipment in a road vehicle are provided in annex D.

Stand alone equipment submitted for testing shall be offered by the provider complete with any ancillary equipment needed for testing. The provider shall declare the frequency range(s), the range of operation conditions and power requirements, as applicable, in order to establish the appropriate test conditions.

The EUT will comprise the sensor, antenna and radome if needed and will be tested as a stand alone assembly. The EUTs test fixtures may be supplied by the provider to facilitate the tests (clause 6.1).

These clauses are intended to give confidence that the requirements set out in the present document have been met without the necessity of performing measurements on all frequencies.

4.1.1 Choice of model for testing

If an equipment has several optional features, considered not to affect the RF parameters then the tests need only to be performed on the equipment configured with that combination of features considered to be the most complex, as proposed by the provider and agreed by the test laboratory.

4.2 Mechanical and electrical design

The equipment submitted by the provider shall be designed, constructed and manufactured in accordance with good engineering practice and with the aim of minimizing harmful interference to other equipment and services.

Transmitters and receivers may be individual or combination units.

4.3 Auxiliary test equipment

All necessary test signal sources and set-up information shall accompany the equipment when it is submitted for testing.

4.4 Interpretation of the measurement results

The interpretation of the results recorded on the appropriate test report for the measurements described in the present document shall be as follows:

- the measured value relating to the corresponding limit shall be used to decide whether an equipment meets the requirements of the present document;
- the measurement uncertainty value for the measurement of each parameter shall be included in the test report;
- the recorded value of the measurement uncertainty shall, for each measurement, be equal to, or lower than, the figures in the table of measurement uncertainty (table 7).

5 Test conditions, power sources and ambient temperatures

5.1 Normal and extreme test conditions

Testing shall be carried out under normal test conditions, and also, where stated, under extreme test conditions.

The test conditions and procedures shall be as specified in clauses 5.2 to 5.4.

5.2 External test power source

During tests the power source of the equipment shall be an external test power source, capable of producing normal and extreme test voltages as specified in clauses 5.3.2 and 5.4.2. The internal impedance of the external test power source shall be low enough for its effect on the test results to be negligible.

The test voltage shall be measured at the point of connection of the power cable to the equipment.

During tests the external test power source voltages shall be within a tolerance of ± 1 % relative to the voltage at the beginning of each test. The level of this tolerance can be critical for certain measurements. Using a smaller tolerance provides a reduced uncertainty level for these measurements.

5.3 Normal test conditions

5.3.1 Normal temperature and humidity

The normal temperature and humidity conditions for tests shall be any convenient combination of temperature and humidity within the following ranges:

- temperature: +15 °C to +35 °C;
- relative humidity: 20 % to 75 %.

When it is impracticable to carry out tests under these conditions, a note to this effect, stating the ambient temperature and relative humidity during the tests, shall be added to the test report.

5.3.2 Normal test power source

The internal impedance of the test power source shall be low enough for its effect on the test results to be negligible. For the purpose of the tests, the voltage of the external test power source shall be measured at the input terminals of the equipment.

5.3.2.1 Mains voltage

The normal test voltage for equipment shall be the nominal mains voltage. For the purpose of the present document, the nominal voltage shall be the declared voltage, or any of the declared voltages, for which the equipment was designed.

The frequency of the test power source corresponding to the ac mains shall be between 49 Hz and 51 Hz.

5.3.2.2 Other power sources

For operation from other power sources the normal test voltage shall be that declared by the provider. Such values shall be stated in the test report.

5.4 Extreme test conditions

5.4.1 Extreme temperatures

5.4.1.1 Procedure for tests at extreme temperatures

Before measurements are made, the equipment shall have reached thermal balance in the test chamber. The equipment shall not be switched off during the temperature stabilizing period.

If the thermal balance is not checked by measurements, a temperature stabilizing period of at least one hour, or such period as may be decided by the accredited test laboratory, shall be allowed. The sequence of measurements shall be chosen, and the humidity content in the test chamber shall be controlled so that excessive condensation does not occur.

5.4.1.2 Extreme temperature ranges

For tests at extreme temperatures, measurements shall be made in accordance with the procedures specified in clause 5.4.1.1, at the upper and lower temperatures of one of the following limits:

- Temperature: -20 °C to +55 °C.

5.4.2 Extreme test source voltages

5.4.2.1 Mains voltage

The extreme test voltages for equipment to be connected to an ac mains source shall be the nominal mains voltage $\pm 10\%$.

5.4.2.2 Other power sources

For equipment using other power sources, or capable of being operated from a variety of power sources, the extreme test voltages shall be that declared by the provider. These shall be recorded in the test report.

6 General conditions

Detailed descriptions of the radiated measurement arrangements are included in annexes A and B. In general, measurements shall be carried out under far field conditions. The far field condition for the EUTs is considered to be fulfilled in a minimum radial distance "X" that shall be a minimum of $2d^2/\lambda$, where d is the largest dimension of the antenna aperture of the EUT, for a single device measurement.

Absolute power measurements shall be made using an appropriate method to ensure that the wave front is properly formed (i.e. operating in far field conditions). The test site shall meet the appropriate requirements as defined in published guidelines/standards.

6.1 Test fixture

6.1.1 Requirements

The test fixture for radio equipment operating in the 24 GHz range shall enable the EUT to be physically supported, together with a wave guide horn antenna RX which is used to measure the transmitted energy, in a fixed physical relationship to the EUT or calibration antenna TX (see figure 1). The test fixture shall be designed for use in an anechoic environment and allow certain measurements to be performed in the far field, i.e. at a distance greater than $2d^2/\lambda$, where d is the largest dimension of the antenna aperture of the EUT.

The test fixture shall incorporate at least one 50 Ω RF connector, a device for electromagnetic coupling to the EUT and a means for repeatable positioning of the EUT.

Its compactness shall enable the whole assembly to be accommodated within a test chamber, usually a climatic facility. The circuitry associated with the RF coupling device shall not contain active or non-linear components.

Only after it has been verified that the test fixture does not affect performance of the EUT, the EUT can be confidently tested.

At set-up, the EUT shall be aligned in the test fixture so that the maximum power is detected at the coupled output (see also clause 7.1.2.2) Orientation of the horn antenna will take into account the polarization of the EUT.

In addition, the test fixture shall provide a connection to an external power supply.

The test fixture shall be provided by the provider together with a full description, which shall meet the approval of the selected accredited test laboratory.

The performance characteristics of the test fixture shall be measured and shall be approved by the accredited test laboratory. It shall conform to the following basic parameters:

- the gain of the waveguide horn shall not exceed 20 dB;
- the physical distance between the front face of the EUT and the waveguide horn shall be between 50 cm and 1 m;
- the minimum distance between the transmitting and receiving antenna shall guarantee mutual far field conditions (distance greater than $2d^2/\lambda$, where d is the largest dimension of the antenna aperture of the EUT);
- the physical height between the centre of the EUT and the supporting structure of the test fixture shall be between 50 cm and 60 cm;

NOTE: Information on uncertainty contributions, and verification procedures are detailed in clauses 5 and 6, respectively, of TR 102 273-2 (see bibliography).

- the Voltage Standing Wave Ratio (VSWR) at the waveguide flange at which measurements are made shall not be greater than 1,5;
- the performance of the test fixture when mounted in the anechoic chamber or in a temperature chamber, shall be unaffected by the proximity of surrounding objects or people inside the chamber. The performance shall be reproducible if the EUT is removed and then replaced;

- the performance of the test fixture shall remain within the defined limits of the calibration report, when the test conditions are varied over the limits described in clauses 5.3 and 5.4.

The characteristics and calibration of the test fixture shall be included in a calibration report.

6.1.2 Calibration

The calibration of the test fixture establishes the relationship between the detected output from the test fixture, and the transmitted power (as sampled at the position of the antenna) from the EUT in the test fixture. This can be achieved by using a calibrated horn with a gain of equal to or less than 20 dBi, fed from an external signal source, in place of the EUT to determine the variations in detected power with temperature and over frequency.

The calibration setup is shown in figure 1.

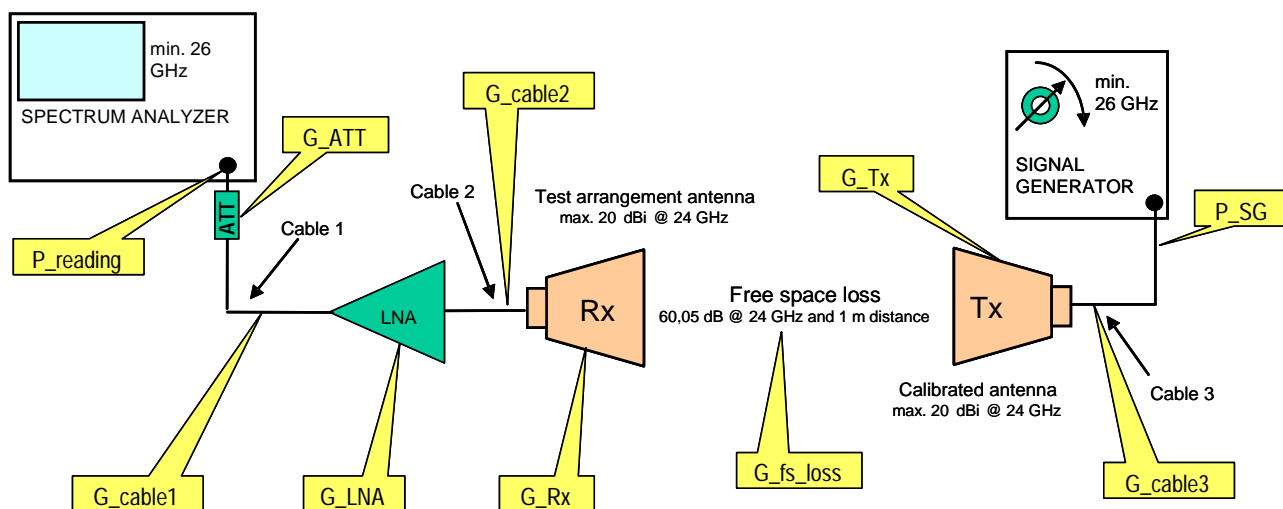

Figure 1: Calibration set-up configuration (example for 1m Rx to Tx free space distance)

The calibration of the test fixture shall be carried out by either the provider or the accredited test laboratory. The results shall be approved by the accredited test laboratory.

It is the responsibility of the tester to obtain enough measurement accuracy. The following description is an example of a proven and accurate calibration method:

- Calibrate all instruments using usual calibration routines.
- Remove the EUT from the test fixture and replace the EUT by a calibrated antenna. Carefully orientate the calibration antenna in the test fixture towards the test arrangement antenna. The reference plane of the calibration antenna shall coincide with the EUT reference plane. The distance between the calibration antenna and the test arrangement antenna shall be between 0,5 m to 1 m.
- Connect a signal generator to the calibrated antenna in the test fixture.
- Connect a 10 dB attenuator to the test arrangement antenna to improve the VSWR. If SNR of the test arrangement is low it might be necessary to omit the attenuator.
- Connect a power meter to the test arrangement antenna including a 10 dB attenuator, if required, and apply, by means of a signal generator, a frequency and power level to the same as the expected value from the EUT output to the calibration antenna in the test fixture.
- Take into account the gain from both the calibration and the test arrangement antenna, the losses from the attenuator and all cables in use and the gain of a LNA, if required.
- Note the absolute reading of the power meter.

- h) Replace the power meter with a spectrum analyser. Adjust the frequency and power level of the signal generator to the same as the expected value from the EUT output. Apply this signal to the calibration antenna.
- i) Take into account the gain from both the calibration and the test arrangement antenna, the losses from the attenuator and all cables in use and the gain of a LNA, if required. Instead of an external attenuator the built-in attenuator of the spectrum analyser may be used.
- j) Set the spectrum analyser detector in RMS mode with a RBW and VBW at least as large as the signal generator output signal bandwidth with an appropriate spectrum analyser sweep rate. Note the absolute reading of the spectrum analysers input signal.
- k) The noted absolute power reading of the power meter and the spectrum analyser shall not differ more than the specified uncertainty of the used measurement equipments.
- l) Calculate the total attenuation from the EUT reference plane to the spectrum analyser as follows:

P_reading	=	the absolute power level noted from the power meter/spectrum analyser
G_Tx	=	antenna gain of the calibrated antenna in the test fixture
G_Rx	=	antenna gain of the test arrangement antenna
G_ATT	=	the 10 dB attenuator loss (0 dB, if attenuator not used)
G_cable	=	the total loss of all cables used in the test setup
G_LNA	=	the gain of the low noise amplifier (0 dB, if LNA not used)
G_fs_loss	=	the free space loss between the calibrated antenna (Tx) in the test fixture and the test arrangement antenna (Rx)
C_ATT	=	calculated attenuation of all losses with referenced to the EUT position
P_abs	=	the absolute power of the EUT (e.i.r.p.)
C_ATT	=	$G_{fs_loss} - G_{Rx} + G_{cable2} - G_{LNA} + G_{cable1} + G_{ATT}$
P_abs	=	$P_{reading} - C_{ATT}$

The calibration should be carried out at a minimum of three frequencies within the operating frequency band, at the declared polarization of the EUT, and over the temperature ranges specified in clause 5.3.1.

6.1.3 General requirements for RF cables

All RF cables including their connectors at both ends used within the measurement arrangements and set-ups shall be of coaxial type featuring within the frequency range they are used:

- a nominal characteristic impedance of 50 Ω ;
- a VSWR of less than 1,2 at either end;
- a shielding loss in excess of 60 dB.

All RF cables exposed to radiation shall be loaded with ferrite beads spaced at distance D_{fb} apart from each other along the entire length of the cable. Such cables are referred to as ferrited cables. The distance D_{fb} shall be smaller than half of the signal wavelength under test.

All RF cables shall be routed suitably in order to reduce impacts on antenna radiation pattern, antenna gain, antenna impedance.

NOTE: Further details are provided in TR 102 273-2 (see bibliography).

6.1.4 Shielded anechoic chamber

Due to the low power emitted by the EUT, the test site shall be a shielded anechoic chamber.

A typical anechoic chamber is shown in figure 2. This type of test chamber attempts to simulate free space conditions.

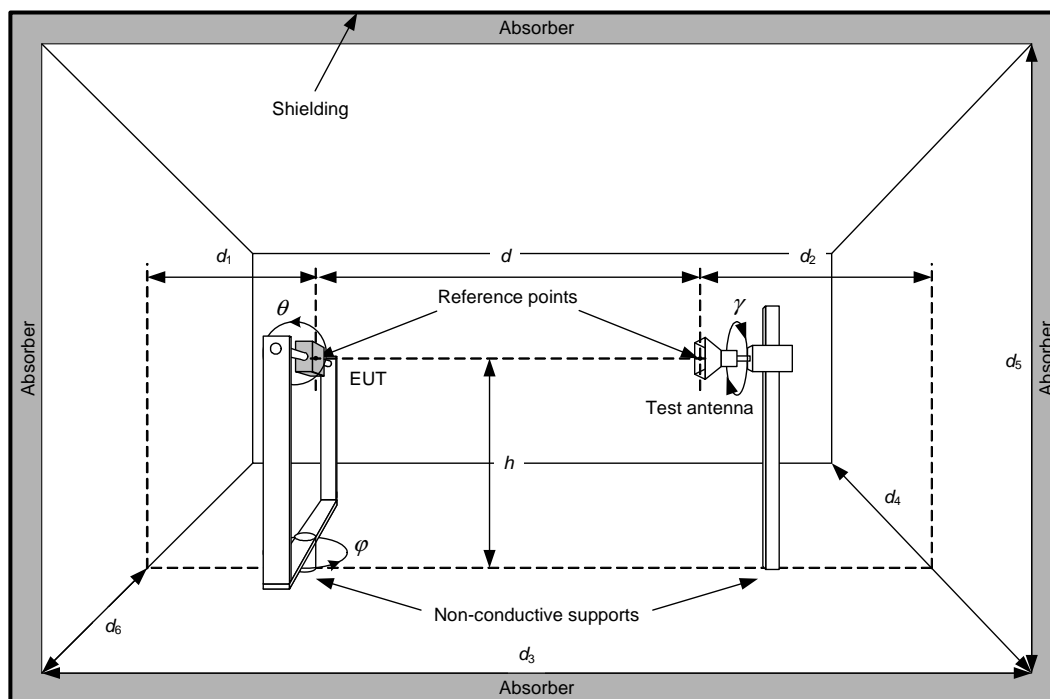

Figure 2: Typical anechoic chamber

The chamber contains suitable antenna supports on both ends.

The supports carrying the test antenna and EUT shall be made of a non-permeable material featuring a low value of its relative permittivity.

The anechoic chamber shall be shielded. Internal walls, floor and ceiling shall be covered with radio absorbing material. The shielding and return loss for perpendicular wave incidence vs. frequency in the frequency range as of 300 MHz shall meet:

- 105 dB shielding loss;
- 30 dB return loss.

Both absolute and relative measurements can be performed in an anechoic chamber. Where absolute measurements are to be carried out the chamber shall be verified.

The shielded anechoic chamber test site shall be calibrated and validated for the frequency range being applicable.

NOTE 1: Information on uncertainty contributions, and verification procedures are detailed in clauses 5 and 6, respectively, of TR 102 273-2 (see bibliography).

NOTE 2: Further information on shielded anechoic chambers is given in clause A.3.

7 Methods of measurement and limits for transmitter parameters

The emitted spectrum from SRRs consists of two different emissions:

- a) Single carrier emissions in the SRD band from 24,05 GHz to 24,25 GHz.
- b) Broadband emissions in the 22,000 GHz to 26,65 GHz.

The methods of measurement are different for the single carrier emissions (measured over the entire bandwidth as described in clause 7.1.4) and the broadband emissions (measured in a 1 MHz bandwidth for average power as described in clause 7.1.2 and measured in a 3 MHz bandwidth for peak power in as described in clause 7.1.3).

7.1 Methods of measurement and limits for transmitters in the 22,000 GHz to 26,65 GHz band

To meet the requirements for all applications the EUT shall be measured at its maximum peak and mean output power level and maximum antenna gain. Antenna polar diagrams and details of polarization, shall be presented and agreed with the accredited test laboratory if they are necessary to enable the measurements described in clause 7.2.3 to be performed.

Alternative test methods to those described within the present document may be used with the agreement of the provider, and at the discretion of the accredited test laboratory. Procedures shall comply with CEPT/ERC/REC 01-06 [3] and CISPR 16 (parts 1-1, 1-4 and 1-5) [2].

For 24 GHz EUTs the type of modulation has to be stated in the test specification.

7.1.1 Permitted range of operating frequencies

7.1.1.1 Definition

The permitted range of operating frequencies is the frequency range over which the equipment is authorized to operate.

7.1.1.2 Method of measurement

The minimum and maximum output frequencies at which the permitted spurious and out-of-band emission levels as specified in clause 7.2 are exceeded due to intentional emission from the radio transmitter, determine the operating range of the EUT.

The permitted range of frequencies shall be measured using the method shown in figure 3. If the measuring receiver is capable of measuring the signals directly without any down mixing, the fundamental or harmonic mixer can be omitted. If more than one modulation scheme can be generated by the EUT, then the maximum and minimum frequencies generated by each modulation scheme shall be measured and recorded separately.

The measuring receiver may be a spectrum analyser, oscilloscope, selective power meter or any measuring receiver which is appropriate to perform the intended measurement of the EUT.

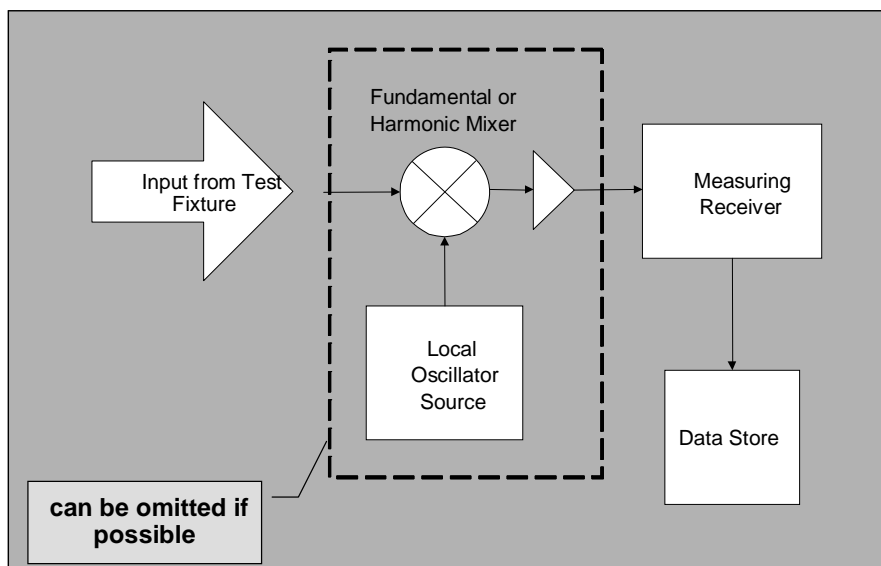

Figure 3: Test equipment for measuring the operating frequency range

This measurement shall be performed at normal and at extreme test conditions (see clauses 5.3 and 5.4).

The method of measurement shall be documented in the test report.

7.1.1.3 Limits

The permitted range of operating frequency for intentional emissions shall be from 22,000 GHz to 26,65 GHz. Outside the permitted range of operating frequencies the intentional emissions shall be reduced by no less than 20 dB.

7.1.2 Maximum radiated average power density (e.i.r.p.)

7.1.2.1 Definition

The maximum radiated average power density (e.i.r.p.) is defined as the emitted power density in a one MHz bandwidth of the transmitter including antenna gain according to the procedure given in the following clause. See clause 5 for the test conditions.

7.1.2.2 Method of measurement

Using an applicable measurement procedure e.g. as described in annexes A and B, the power density shall be measured according to figure 4 and recorded in the test report. The method of measurement shall be documented in the test report.

The tests shall be made in an anechoic-shielded chamber, as the measured levels often are lower than the ambient environmental noise.

The test set-up is shown in figure 4.

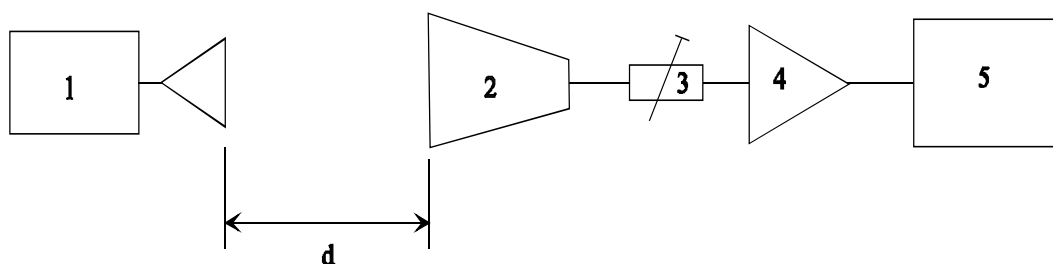

Key:

1. Equipment under test with integrated antenna.
2. Double ridged guide horn antenna (wideband test antenna).
3. Variable step attenuator.
4. Low noise, pulse rated, high gain, wideband preamplifier.
5. Spectrum analyser.

Figure 4: Test set-up for power density measurements of transmitters operating in the 22,000 GHz to 26,65 GHz band

The minimum performance data for preamplifier (key 4) and horn antenna (key 2) are shown in clause B.2.

The following spectrum analyser settings shall be used:

- Resolution bandwidth = 1 MHz.
- Video bandwidth ≥ 3 MHz.
- Detector mode: r.m.s. with an averaging time of less than 50 ms/MHz.

The test procedure is the following:

- a) Set the EUT in normal operation mode.
- b) The test antenna (2) is positioned at a measurement distance of approximately 1 m from the equipment under test (1).
- c) The equipment under test (1) and the test horn antenna (2) are orientated for maximum reading at the spectrum analyser (5).
- d) Starting with maximum attenuation, the attenuation of the variable step attenuator (3) is gradually reduced. The corresponding increased reading on the spectrum analyser (5) is simultaneously monitored until a 1 dB compression of the preamplifier (4) is detected. The attenuation is then increased by 3 dB.
- e) The measured spectrum curve at the spectrum analyser (5) is recorded over an amplitude range of approximately 35 dB. Measurements of power densities below -75 dBm/MHz (e.i.r.p.) are not required.
- f) The frequency, f_c , at which the amplitude of the radiated spectrum is maximum is determined from the spectrum analyser curve in point d) above.
- g) The lower frequency, f_l , and the higher frequency, f_h , where the radiated spectrum density is 20 dB below maximum, as determined in e) above, are recorded.
- h) The equipment under test (1) is substituted by an unmodulated signal generator connected to an antenna having gain, G_a . The antenna is positioned in front of the test horn antenna (2) at the same measurement distance d as for a) above and is orientated for maximum reading at the spectrum analyser. The signal generator frequency is adjusted to f_c and its output power adjusted until the spectrum analyser (5) reading is identical with the maximum level of the radiated spectrum according to point d) above. The signal generator output power, P_s , is measured with power meter and the radiated power (e.i.r.p.) is calculated as:

$$P_{\text{rad}} = P_s \text{ (dBm)} + G_a \text{ (dB) e.i.r.p}$$

7.1.2.3 Limits

The transmitter maximum radiated average power density (e.i.r.p.) under normal and extreme test conditions shall not exceed the values given in table 1 and illustrated in figure 5.

Table 1: Limits for broadband maximum radiated average power density (e.i.r.p.) in the frequency band from 22,000 GHz to 26,65 GHz

	Frequency f [GHz]		
	22,000 < f < 22,65	22,65 < f < 25,65	25,65 < f < 26,65
Maximum radiated average power density (e.i.r.p.) [dBm/MHz]	$-61,3 + 20 \times (f - 21,65 \text{ GHz}) / 1 \text{ GHz}$	-41,3	$-41,3 - 20 \times (f - 25,65 \text{ GHz}) / 1 \text{ GHz}$

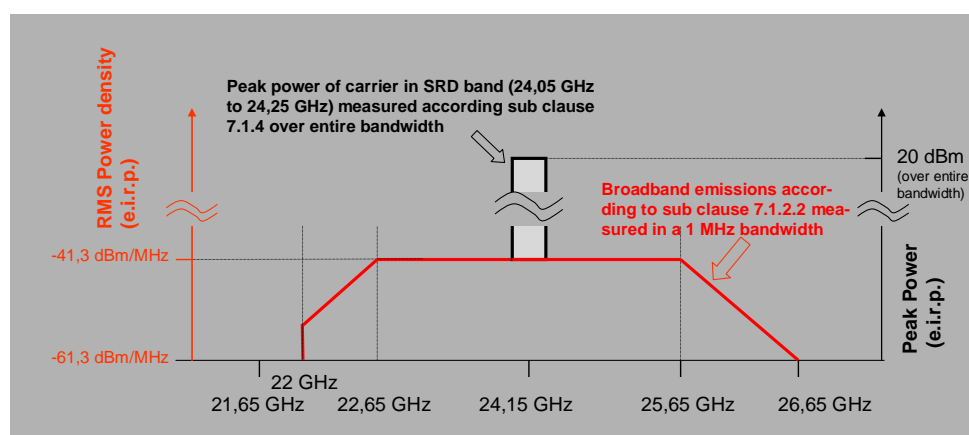

NOTE: The transmitter peak power emission limits within the frequency range from 24,05 GHz to 24,25 GHz are defined in clause 7.1.4.

Figure 5: Transmitter maximum radiated average power density (e.i.r.p.) mask for equipment operating in the 22,000 GHz to 26,65 GHz band

7.1.3 Maximum radiated peak power density (e.i.r.p.)

7.1.3.1 Definition

The maximum radiated peak power density including antenna gain (e.i.r.p.) is defined as the peak power measured in a 50 MHz bandwidth. As it is difficult to measure the peak power in a 50 MHz bandwidth with spectrum analysers, the test is measuring the peak power in a resolution bandwidth greater than 1 MHz according to the procedure given in the following clause 7.1.3.2. See clause 5 for the test conditions.

7.1.3.2 Method of measurement

This method of measurement is using similar test set-up as given in figure 4. The necessary steps for measurement of radiated peak power are:

- The peak power measurement is based on a 50 MHz measurement bandwidth. No further correction factor (PDCF) is applied to the readings measured in the 50 MHz RBW. With standard commercial test equipment such large RBW is not feasible. Furthermore the VBW shall be at least as large as the RBW for correct peak measurements. Therefore a resolution bandwidth of 3 MHz shall be used. The measurement shall be centred on the frequency at which the highest radiated emission occurs.
- The procedure described in clause 7.1.2.2 indents a) to g) shall be used. The following spectrum analyser settings may be used:
 - Resolution bandwidth = 3 MHz.
 - Video bandwidth = 3 MHz.

- Detector mode = Peak with max hold.
- The measured radiated peak power in a 3 MHz bandwidth, $P_{PK\ 3MHz}$, is measured and recorded.
- The analyser should be used in a maximum-hold trace mode. The method of measurement shall be documented in the test report.

7.1.3.3 Standard procedure and setup extensions

As the emitted power levels are close or below the spurious emission limits, modifications in the configuration setup (e.g. reduction of the measurement distance, use of a microwave low noise amplifier in the test equipment receiver path to get enough power level above the noise floor, etc.) might become necessary.

The peak power measurement is based on a 50 MHz measurement bandwidth. No further correction factor (PDCF) is applied to the readings measured in the 50 MHz RBW.

With standard commercial test equipment such large RBW is not feasible. Furthermore the VBW must be at least as large as the RBW for correct peak measurements.

The largest VBW on a spectrum analyser is about 10 MHz, so the widest RBW that could be employed should be 10 MHz. To compensate for the differences in RBW from 50 MHz to 3 MHz, the worst case assumption of a 20 log relationship is used, i.e. reducing the RBW from 50 MHz to 3 MHz results in an attenuation of the peak limit of $20 \log(3/50)$ or -24,44 dB. If peak measurements were to be performed using a 1 MHz RBW, the peak limit would be decreased by $20 \log(1/50)$ or -34 dB.

To illustrate the above mentioned with an example, for a given peak limit of 0 dBm in 50 MHz RBW, the following limits in other RBWs are equivalent:

- 0 dBm in 50 MHz RBW; or
- -24,44 dBm in 3 MHz RBW; or
- -34 dBm in 1 MHz RBW.

The RBW must be centred on the frequency at which the highest radiated emission occurs. Any RBW within 1 MHz and 50 MHz with the peak limit correction following the square of the change in RBW (i.e. 20 log relationship) could be possible.

The analyser should be used in a maximum-hold trace mode.

The method of measurement shall be documented in the test report.

7.1.3.4 Limits

The transmitter maximum peak power density (e.i.r.p.) under normal and extreme test conditions shall not exceed the values given in table 2 and depicted in figure 6.

Table 2: Limits for broadband maximum transmitted peak power density (e.i.r.p.) in the 22,000 GHz to 26,65 GHz band

	Frequency f [GHz]		
	22,000 < f < 22,65	22,65 < f < 25,65	25,65 < f < 26,65
Peak Power density (e.i.r.p.) [dBm/3 MHz]	$-44,44 + 20 \times (f - 21,65 \text{ GHz}) / 1 \text{ GHz}$	-24,44	$-24,44 - 20 \times (f - 25,65 \text{ GHz}) / 1 \text{ GHz}$

NOTE: The transmitter peak power emission limits within the frequency range from 24,05 GHz to 24,25 GHz are defined in clause 7.1.4.

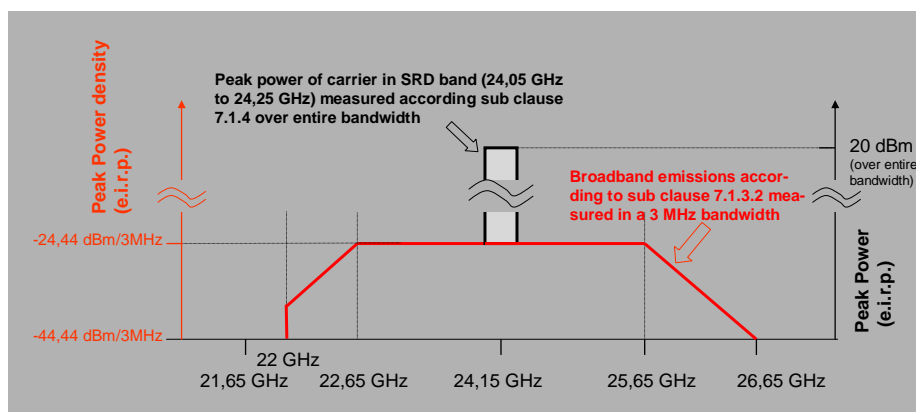

Figure 6: Transmitter maximum radiated peak power density (e.i.r.p.) mask for equipment operating in the 22,000 GHz to 26,65 GHz band

7.1.4 Methods of measurement and limits for emissions in the 24,05 GHz to 24,25 GHz band

7.1.4.1 Equivalent isotropically radiated power (e.i.r.p.)

7.1.4.1.1 Definition

The e.i.r.p. is defined as the peak power of the transmitter and calculated according to the procedure given in the following clause. See clause 5 for the test conditions.

7.1.4.1.2 Method of measurement

Using the applicable measurement procedure as described in annex B, the power output shall be measured and recorded in the test report. The method of measurement shall be documented in the test report.

In order to measure e.i.r.p. it is first necessary to determine the appropriate method of measurement to be used, see clauses 7.1.4.1.2.1 and 7.1.4.1.2.2. The -6 dB transmitter bandwidth shall be determined using a 100 kHz measuring bandwidth in order to establish which measurement method is applicable.

7.1.4.1.2.1 Transmitters with a -6 dB bandwidth up to 20 MHz

This method of measurement shall only be used for:

- non spread spectrum equipment with a -6 dB bandwidth of 20 MHz or less and a duty cycle above 50 %;
- spread spectrum equipment with a -6 dB channel bandwidth of 1 MHz or less.

Other transmitters shall be tested according to clause 7.1.4.1.2.2.

The equipment shall be able to operate in a continuous transmit mode for testing purposes, where possible.

For FHSS systems, the hop frequency which provides the maximum indicated level shall be used. The frequency shall be indicated in the test report.

For peak power measurements, a spectrum analyser or selective voltmeter shall be used and tuned to the transmitter carrier at which the highest level is detected.

Measurements shall be performed at normal and extreme conditions (see clauses 5.3 and 5.4).

The e.i.r.p. is calculated according to the relevant method stated in annex B.

7.1.4.1.2.2 Other transmitters than defined in clause 7.1.4.1.2.1

This method of measurement shall be used for:

- a) non spread spectrum equipment with a -6 dB bandwidth greater than 20 MHz;
- b) equipment with a duty cycle below 50 %;
- c) spread spectrum equipment with a -6 dB channel bandwidth above 1 MHz.

The measurement shall be performed using normal operation of the equipment with test modulation applied.

The test procedure shall be as follows:

Step 1:

- using suitable attenuators, the output power of the transmitter shall be coupled to a matched diode detector. The output of the matched diode detector shall be connected to the vertical channel of an oscilloscope;
- the combination of the matched diode detector and the oscilloscope shall be capable of faithfully reproducing the envelope peaks and the duty cycle of the transmitter output signal;
- the observed duty cycle of the transmitter (Tx on/(Tx on + Tx off)) shall be noted as x ($0 < x \leq 1$), and recorded in the test report. For the purpose of testing, the equipment shall be operated with a duty cycle that is equal to or greater than 0,1. Where this duty cycle is not possible, then this shall be stated on the test report and the actual duty cycle shall be declared.

Step 2:

- the average output power of the transmitter shall be determined using a wideband calibrated RF power meter with a matched thermocouple detector or an equivalent thereof and with an integration period that exceeds the repetition period of the transmitter by a factor 5 or more. The observed value shall be noted as "A" (in dBm);
- the e.i.r.p. shall be calculated from the above measured power output A (in dBm) the observed duty cycle x , and the declared antenna gain(s) "G" in dBi, according to the formula:
 - $P = A + G + 10 \log (1/x)$ (dBm).
 - P shall not exceed the value specified in table 3, and shall be recorded in the test report.

Step 3:

- the measurement set up as given under step 1 shall be used to determine, on the oscilloscope, the peak of the envelope of the output signal of the transmitter;
- the maximum (peak) deviation of the Y-trace of the oscilloscope shall be noted as "B".

Step 4:

- the transmitter shall be replaced by a signal generator. The output frequency of the signal shall be made equal to the centre of the frequency range occupied by the transmitter;
- the signal generator shall be unmodulated. The output power of the signal generator shall be raised to a level such that the deviation of the Y-trace of the oscilloscope reaches level B, as indicated in step 3;
- this output level "C" (in dBm) of the signal generator shall be determined using a wideband, calibrated RF power meter with a matched thermocouple detector or an equivalent thereof;
- level C shall not exceed by more than 3 dB the value specified in table 3, converted into dBm, minus the antenna gain(s) G in dBi;
- the measurement shall be repeated at the lowest, the middle, and the highest frequency of the declared frequency range. These frequencies shall be recorded in the test report.

Measurements shall be performed at normal and extreme conditions (see clauses 5.3 and 5.4).

7.1.4.1.3 Limits

Table 3: Limit for transmitted peak power in the 24,05 GHz to 24,25 GHz SRD band

	Limit
Peak Power (e.i.r.p.)	20 dBm

In addition, peak power emissions exceeding -10 dBm e.i.r.p. are restricted to a maximum duty cycle limit of 10 %.

7.1.4.2 Permitted range of operating frequencies

The frequency range of the equipment is determined by the lowest and highest frequencies occupied by the power envelope in accordance with CEPT/ERC/REC 70-03:

- f_H is the highest frequency of the power envelope, it is the frequency furthest above the frequency of maximum power where the output power drops below the level of -74,8 dBm/Hz spectral power density (-30 dBm if measured in a 30 kHz reference bandwidth) e.i.r.p.
- f_L is the lowest frequency of the power envelope; it is the frequency furthest below the frequency of maximum power where the output power drops below the level of -74,8 dBm/Hz spectral power density (-30 dBm if measured in a 30 kHz reference bandwidth) e.i.r.p.

7.1.4.2.1 Definition

The permitted range of operating frequencies includes all frequencies on which the equipment may operate within an assigned frequency band. The operating frequency range shall be declared by the provider.

The range of frequencies, determined by clause 7.1.4.2.2, shall be specified in the test report.

7.1.4.2.2 Method of measurement for equipment not using FH modulation

The method of measurement for equipment employing pulsed FH modulation is given in clause 7.1.4.2.3.

Using applicable conducted measurement procedures, as described in annex B, the frequency range(s) shall be measured and recorded in the test report.

These measurements shall be performed under both normal and extreme operating conditions as defined in clauses 5.3 and 5.4.

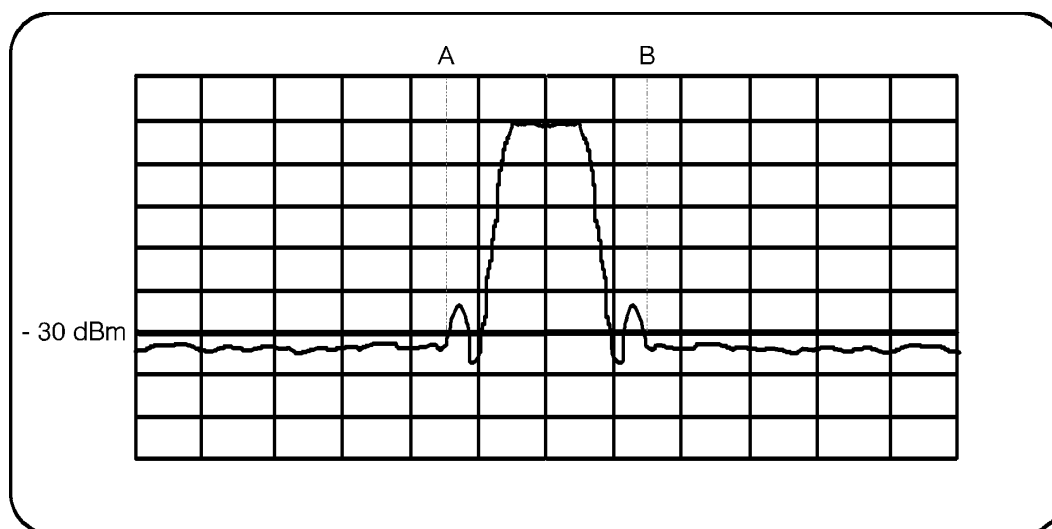
**Figure 7: Measuring the extreme frequencies of the power envelope**

The measurement procedure shall be as follows:

- a) put the spectrum analyser in video averaging mode with a minimum of 50 sweeps selected;
- b) select the lowest operating frequency of the equipment under test and activate the transmitter with modulation applied. The RF emission of the equipment shall be displayed on the spectrum analyser. The display will form an image like that shown in figure 7;
- c) using the marker of the spectrum analyser, find the lowest frequency below the operating frequency at which spectral power density drops below the level given in clause 7.1.4.2 (see A in figure 7). This frequency shall be recorded in the test report;
- d) select the highest operating frequency of the equipment under test and find the highest frequency at which the spectral power density drops below the value given in clause 7.1.4.2 (see B in figure 7). This frequency shall be recorded in the test report;
- e) the difference between the frequencies measured in steps c) and d) is the operating frequency range. It shall be recorded in the test report.

This measurement shall be repeated for each frequency range declared by the provider.

7.1.4.2.3 Method of measurement for equipment using pulsed FH modulation

Using an applicable conducted measurement procedure as described in annex B the frequency range of the equipment shall be measured and recorded in the test report.

The transmitter power level shall be set to the rated power level.

These measurements shall be performed under both normal and extreme operating conditions as defined in clauses 5.3 and 5.4.

The measurement procedure shall be as follows:

- a) put the spectrum analyser in video averaging mode with a minimum of 50 sweeps selected;
- b) select the lowest hop frequency of the equipment under test and activate the transmitter with modulation applied. The display will form an image similar to that shown in figure 7;
- c) find the lowest frequency below the operating frequency at which spectral power density drops below the level given in clause 7.1.4.2 (see A in figure 7). This frequency shall be recorded in the test report;
- d) select the highest hop frequency of the equipment under test and find the highest frequency at which the spectral power density drops below the level given in clause 7.1.4.2 (see B in figure 7). This frequency shall be recorded in the test report;
- e) the difference between the frequencies measured in steps c) and d) is the frequency range. It shall be recorded in the test report.

This measurement shall be repeated for each operating frequency range declared by the provider.

7.1.4.2.4 Limit

The width of the power envelope is $f_H - f_L$ for a given operating frequency. In equipment that allows adjustment or selection of different operating frequencies, the power envelope takes up different positions in the allowed band. The frequency range limits are determined by the lowest value of f_L and the highest value of f_H resulting from the adjustment of the equipment to the lowest and highest operating frequencies.

The transmitted power under normal and extreme test conditions for equipment operating in the 24,050 GHz to 24,250 GHz band with fixed beam antennas shall be less than the limits shown in table 3 in clause 7.1.4.1.3.

7.1.5 Vertical plane transmitter emissions in the 23,6 GHz to 24 GHz range

7.1.5.1 Definition

The vertical plane transmitter emissions are defined as emissions of the antenna as a function of the elevation angle, normalized to the maximum emission at boresight.

7.1.5.2 Measurement procedure

- a) The measurement of the EUT shall be done at 23,6 GHz, 23,8 GHz and 24 GHz.
- b) The EUT shall be operated in a mode or test mode where the highest emissions can be achieved.
- c) Only the relative attenuation to the maximum bore sight direction shall be measured.
- d) Measurement is done with a spectrum analyser with peak detector in maxhold with largest RBW and VBW possible.
- e) The provider shall indicate the normal mounting orientation of the EUT.
- f) A test fixture similar to figure 1 can be used. The EUT is fixed on a mechanism that allows pivoting of the device either in a vertical or horizontal plane in both directions up to minimum of 90°. The EUT is fixed in a way that its elevation plane coincides with the pivoting plane. The maximum bore sight direction is adjusted and referred to as the 0° origin.
- g) The EUT is turned to the left and right from the bore sight direction in minimum 2° steps up to 90° and the respective emission values are noted.
- h) Determine the relative emission attenuation from the bore sight maximum value to both sides (e.g. in a polar-log antenna diagram).
- i) Verify if the vertical emission limits of clause 7.1.5.3 are fulfilled.

The results shall be documented in the test report.

7.1.5.3 Vertical emission limits in the 23,6 GHz to 24,0 GHz range

SRR equipment operating in the 22,000 GHz to 26,65 GHz shall apply directional antennas.

Following proper installation, any emissions within the 23,6 GHz to 24 GHz band that appear 38° or greater above the horizontal plane shall be attenuated by 25 dB below the limit specified in clauses 7.1.2.3 and 7.1.3.4.

For equipment authorized, manufactured or imported up to December 31st, 2009 this level of attenuation shall be 25 dB for any emissions within the 23,6 GHz to 24 GHz band that appear 30° or greater above the horizontal plane.

For equipment authorized, manufactured or imported on or after January 1, 2010, this level of attenuation shall be 30 dB for any emissions within the 23,6 GHz to 24 GHz band that appear 30° or greater above the horizontal plane. This level of attenuation can be achieved through the antenna directivity, through a reduction in output power or any other means.

7.2 Radiated spurious and out-of-band emissions

7.2.1 Definition

Spurious emissions are emissions radiated by the antenna of the EUT or its cabinet on a frequency, or frequencies, outside the permitted range of frequencies occupied by the transmitter. Spurious emissions include harmonic emissions, parasitic emissions, intermodulation products and frequency conversion products, but exclude out-of-band emissions.

Out-of-band emissions are residual emissions related to the intentional emissions radiated by the antenna of the EUT on the frequencies immediately outside the permitted range of frequencies which results from the modulation process.

Spurious emissions and out-of-band emissions are measured as spectral power density under normal operating conditions.

7.2.2 Measuring receiver

The term "measuring receiver" refers to either a selective voltmeter or spectrum analyser. The bandwidth of the measuring receiver shall, where possible, be according to CISPR 16 (parts 1-1, 1-4 and 1-5) [2]. In order to obtain the required sensitivity a narrower bandwidth may be necessary, this shall be stated in the test report form.

The bandwidth of the measuring receiver shall be less than the maximum given in table 4.

Table 4: Maximum receiver bandwidths

Frequency being measured (f)	Maximum measuring receiver bandwidth
$f < 1\,000$ MHz	100 kHz to 120 kHz
$f \geq 1\,000$ MHz	1 MHz

7.2.3 Method of measurement for radiated spurious or out-of-band emissions

A test site such as one selected from annex A, which fulfils the requirements of the specified frequency range of this measurement shall be used. The test method employed should be as described in annex B. The bandwidth of the measuring receiver shall be set to a suitable value to correctly measure the spurious or out-of-band emissions. This bandwidth shall be recorded in the test report. For frequencies above 40 GHz a down converter may be used as shown in figure 8. The local oscillator used to down convert the received signals shall be stable and with a phase noise of better than -80 dBc/Hz at 100 kHz offset. The local oscillator frequency shall be selected such that the down converted signal is within the accepted band of the spectrum analyser, and maintaining an adequate Intermediate Frequency (IF) bandwidth to capture the full spectrum of the signal. The e.i.r.p. of the EUT shall be measured and recorded. For these measurements it is strongly recommended to use a Low Noise Amplifier (LNA) before the SA input to achieve the required sensitivity. Measurements shall not be required at frequencies where the spectral power density falls below -75 dBm/MHz.

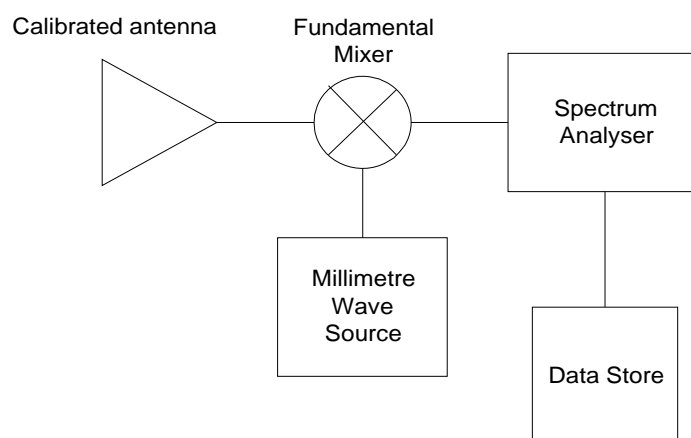

Figure 8: Test equipment for measuring spurious or out-of-band radiation above 40 GHz

7.2.4 Limits

The equivalent isotropically radiated power of any spurious or out-of-band emission shall not exceed the values given in tables 5 and 6 in accordance to CEPT/ERC/REC 74-01.

Table 5: Limits of radiated spurious emissions

Frequency range	Limit values for radiated spurious emissions
47 MHz to 74 MHz	-54 dBm
87,5 MHz to 118 MHz	-54 dBm
174 MHz to 230 MHz	-54 dBm
470 MHz to 862 MHz	-54 dBm
otherwise in band 30 MHz to 1 000 MHz	-36 dBm
1 000 MHz to 100 000 MHz (see note)	-30 dBm
NOTE: Not applicable within the permitted range of frequencies for the 24 GHz SRR from 22,000 GHz to 26,65 GHz.	

Table 6: Limits of radiated out-of-band emissions

Frequency range	Limit values for radiated out of band emissions
10 000 MHz to 40 000 MHz	-61,3 dBm

8 Methods of measurement and limits for receiver parameters

8.1 Receiver spurious emissions

8.1.1 Definition

Separate radiated spurious measurements need not be made on receivers co-located with transmitters. The definitions from clause 7.2.1 on transmitter spurious and out-of-band emissions apply.

8.1.2 Method of measurement - radiated spurious emissions

This method of measurement applies to receivers having an integral antenna.

- a) A test site selected from annex A which fulfils the requirements of the specified frequency range of this measurement shall be used. The test antenna shall be oriented initially for vertical polarization and connected to a measuring receiver. The bandwidth of the measuring receiver shall be adjusted until the sensitivity of the measuring receiver is at least 6 dB below the spurious emission limit given in clause 7.2.4. This bandwidth shall be recorded in the test report.

The receiver under test shall be placed on the support in its standard position.

- b) The frequency of the measuring receiver shall be adjusted over the frequency range from 25 MHz to 50 GHz. The frequency of each spurious component shall be noted. If the test site is disturbed by radiation coming from outside the site, this qualitative search may be performed in a screened room with reduced distance between the transmitter and the test antenna.
- c) At each frequency at which a component has been detected, the measuring receiver shall be tuned and the test antenna shall be raised or lowered through the specified height range until the maximum signal level is detected on the measuring receiver.
- d) The receiver shall be rotated up to 360° about a vertical axis, to maximize the received signal.

- e) The test antenna shall be raised or lowered again through the specified height range until a maximum is obtained. This level shall be noted.
- f) The substitution antenna (see clause A.2.1) shall replace the receiver antenna in the same position and in vertical polarization. It shall be connected to the signal generator.
- g) At each frequency at which a component has been detected, the signal generator, substitution antenna and measuring receiver shall be tuned. The test antenna shall be raised or lowered through the specified height range until the maximum signal level is detected on the measuring receiver. The level of the signal generator giving the same signal level on the measuring receiver as in step e) shall be noted. This level, after correction due to the gain of the substitution antenna and the cable loss, is the radiated spurious component at this frequency.
- h) The frequency and level of each spurious emission measured and the bandwidth of the measuring receiver shall be recorded in the test report.
- i) Measurements b) to h) shall be repeated with the test antenna oriented in horizontal polarization.

8.1.3 Limit

The maximum Equivalent Isotropically Radiated Power (max. e.i.r.p.) of any spurious emission outside the permitted range of frequencies, shall not exceed 2 nW (≈ -57 dBm) in the frequency range $25 \text{ MHz} \leq f \leq 1 \text{ GHz}$ and shall not exceed 20 nW (≈ -47 dBm) on frequencies in the range $1 \text{ GHz} < f \leq 22,000 \text{ GHz}$ and $26,65 \text{ GHz} < f \leq 50 \text{ GHz}$ in accordance to CEPT/ERC/REC 74-01.

9 Measurement uncertainty

The accumulated measurement uncertainties of the test system in use, for the parameters to be measured, should not exceed those given in table 7 to ensure that the measurements remain within an acceptable standard.

Table 7: Absolute measurement uncertainty

Parameter	Uncertainty
Radio Frequency (out of band)	$\pm 1 \times 10^{-7}$
Radiated Emission (valid to 100 GHz)	± 6 dB
Temperature	± 1 K
Humidity	± 10 %

The interpretation of the results recorded in the test report for the measurements described in the present document shall be as follows:

- the measured value related to the corresponding limit shall be used to decide whether an equipment meets the requirements of the present document:
 - a) the value of the measurement uncertainty for the measurement of each parameter shall be separately included in the test report;
 - b) the value of the measurement uncertainty shall be, for each measurement, equal to or lower than the figures in table 7.

For the test methods, according to the present document the uncertainty figures shall be calculated according to the methods described in the TR 100 028 [6] and shall correspond to an expansion factor (coverage factor) $k = 1,96$ or $k = 2$ (which provide confidence levels of respectively 95 % and 95,45 % in case where the distributions characterizing the actual measurement uncertainties are normal (Gaussian)).

Table 7 is based on such expansion factors.

The particular expansion factor used for the evaluation of the measurement uncertainty shall be stated.

Annex A (normative): Radiated measurements

A.1 Test sites and general arrangements for measurements involving the use of radiated fields

This annex provides information for test sites to be used for SRR.

For general guidance on the use of radiation test sites refer to CISPR 16 (parts 1-1, 1-4 and 1-5) [2].

A.2 Guidance on the use of radiation test sites

For measurements involving the use of radiated fields, use shall be made of a test site in conformity with the requirements of clause A.3. For measurements above 40 GHz care shall be taken to ensure that the selected test site is appropriate. When using such a test site, the following conditions should be observed to ensure consistency of measuring results.

A.2.1 Substitution antenna

The substitution antenna and signal generator is used to replace the EUT in substitution measurements. For measurements below 1 GHz the substitution antenna shall be half wavelength dipole resonant at the frequency under consideration, or a shortened dipole, calibrated to the half wavelength dipole. For measurements between 1 GHz and 4 GHz either a half wavelength dipole or a horn radiator may be used. For measurements above 4 GHz a horn radiator shall be used. The centre of this antenna shall coincide with the reference point of the EUT it has replaced. This reference point shall be the volume centre of the sample when its antenna is mounted inside the cabinet, or the point where an outside antenna is connected to the cabinet. The distance between the lower extremity of the dipole and the ground shall be at least 300 mm.

A.3 Indoor test site using a fully anechoic RF chamber

For radiation measurements when the frequency of the signals being measured is greater than 30 MHz, use shall be made of an indoor site being a well-shielded anechoic chamber simulating free space environment. If such a chamber is used, this shall be recorded in the test report.

In the range between 30 MHz and 100 MHz some additional calibration may be necessary.

An example of a typical measurement site may be an electrically shielded anechoic chamber being 10 m long, 5 m broad and 5 m high. Walls and ceiling should be coated with RF absorbers of 1 m height. The base should be covered with absorbing material 1 m thick, and a wooden floor, able to carry test equipment and operators. A measuring distance of 3 m to 5 m in the long middle axis of the chamber can be used for measurements up to 12,75 GHz. For frequencies above 12,75 GHz the chamber may be used provided it has been calibrated for use at the frequency being measured. The construction of the anechoic chamber is described in the following clauses.

A.3.1 Example of the construction of a shielded anechoic chamber

Free-field measurements can be simulated in a shielded measuring chamber where the walls are coated with RF absorbers. Figure A.2 shows the requirements for shielding loss and wall return loss of such a room. As dimensions and characteristics of usual absorber materials are critical below 100 MHz (height of absorbers < 1 m, reflection attenuation < 20 dB) such a room is preferably suitable for measurements above 100 MHz. Figure A1 shows the construction of a shielded measuring chamber having a base area of 5 m by 10 m and a height of 5 m.

Ceilings and walls are coated with pyramidal formed RF absorbers approximately 1 m high or equivalent material with the same performance. The base is covered with absorbers which form a non-conducting sub-floor, or with special ground floor absorbers. The available internal dimensions of the room are 3 m × 8 m × 3 m, so that a measuring distance of maximum 5 m in the middle axis of this room is available.

At 100 MHz the measuring distance can be extended up to a maximum of 2λ .

The floor absorbers reduce floor reflections so that the antenna height need not be changed and floor reflection influences need not be considered.

All measuring results can therefore be checked with simple calculations and the measurement uncertainties have the smallest possible values due to the simple measuring configuration.

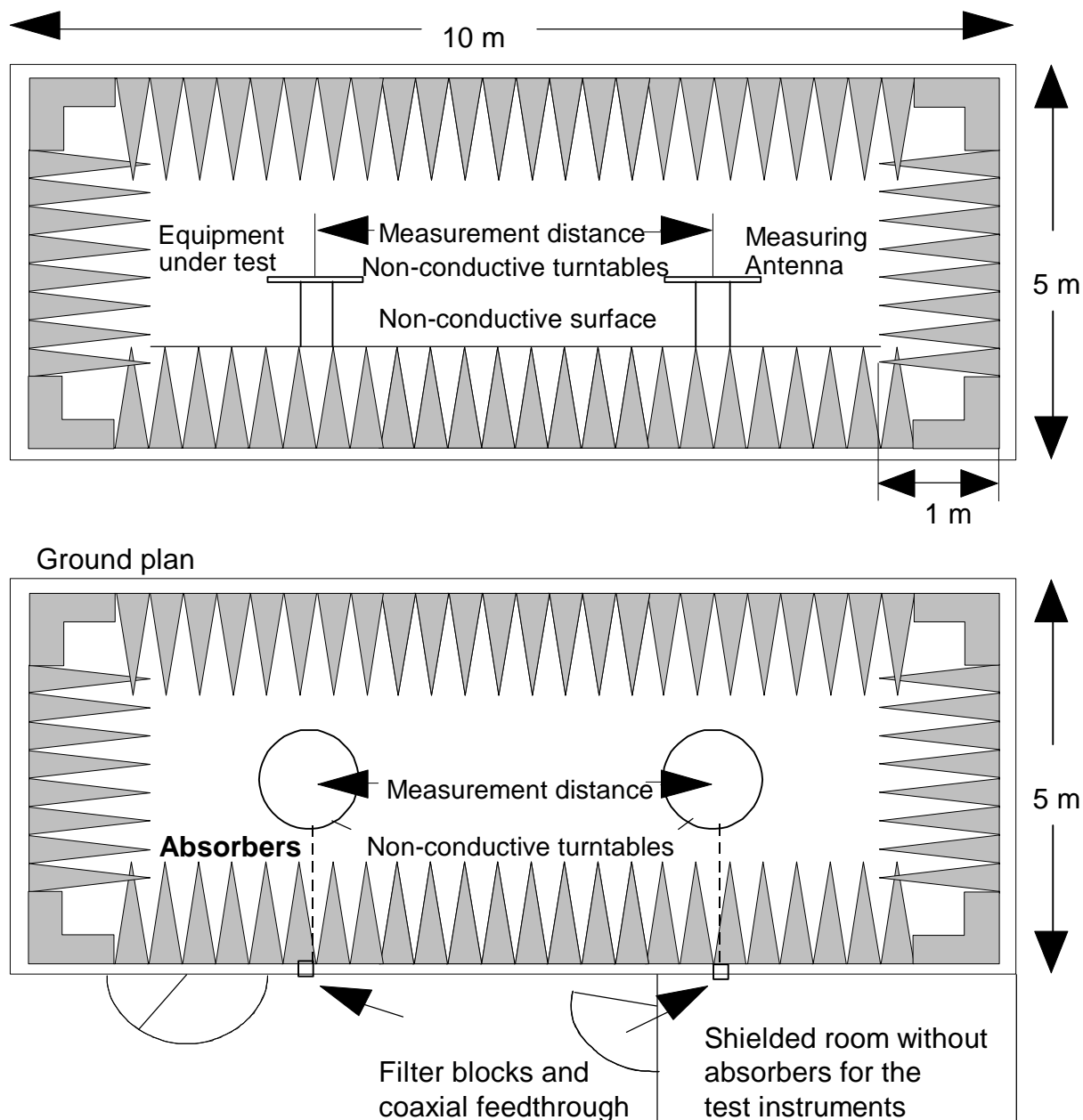

Figure A.1: Example of construction of an anechoic shielded chamber to meet shielding and return loss requirements

A.3.2 Influence of parasitic reflections in anechoic chambers

For free-space propagation in the far field condition the correlation $E = E_0 \times (R_0/R)$ is valid for the dependence of the field strength E on the distance R , whereby E_0 is the reference field strength in the reference distance R_0 .

It is useful to use just this correlation for comparison measurements, as all constants are eliminated with the ratio and neither cable attenuation nor antenna mismatch or antenna dimensions are of importance.

Deviations from the ideal curve can be seen easily if the logarithm of the above equation is used, because the ideal correlation of field strength and distance can then be shown as a straight line and the deviations occurring in practice are clearly visible. This indirect method shows the disturbances due to reflections more readily and is far less problematical than the direct measurement of reflection attenuation.

With an anechoic chamber of the dimensions of clause A.3 at low frequencies up to 100 MHz there are no far field conditions, and therefore reflections are stronger so that careful calibration is necessary. In the medium frequency range from 100 MHz to 1 GHz the dependence of the field strength on the distance meets the expectations very well. In the frequency range of 1 GHz to 100 GHz, because more reflections will occur, the dependence of the field strength on the distance will not correlate so closely.

A.3.3 Calibration of the shielded RF anechoic chamber

Calibration of the chamber shall be performed over the range 30 MHz to 100 GHz.

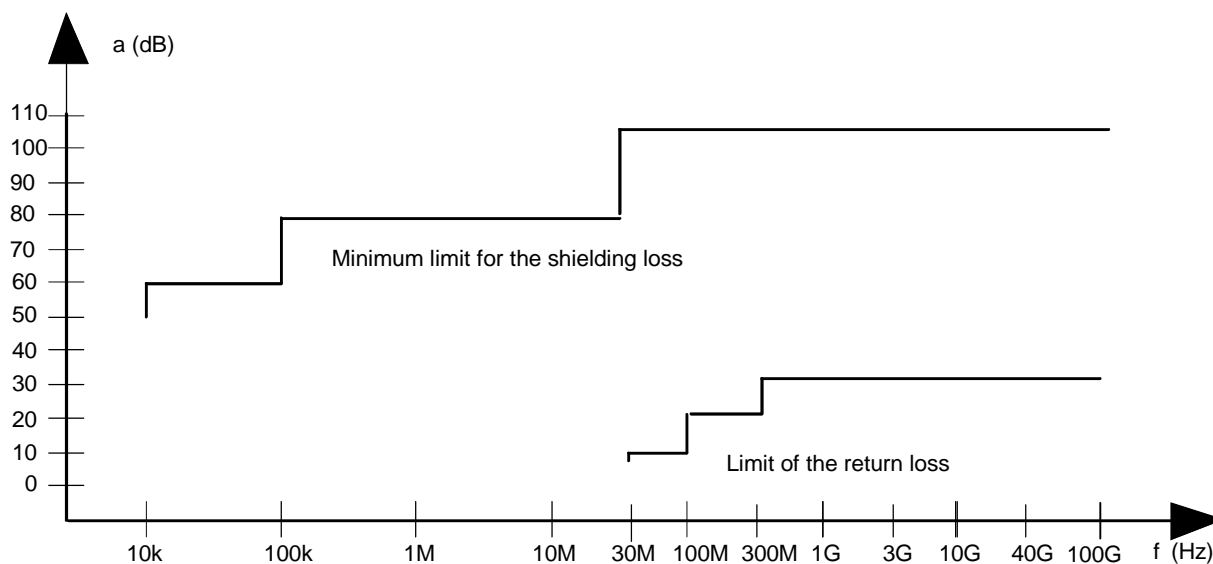

Figure A.2: Specification for shielding and reflections

Annex B (normative): General description of measurement methods

B.1 Radiated measurements

Radiated measurements shall be performed with the aid of a test antenna and measuring receiver as described in annex A. The test antenna and measurement receiver, spectrum analyser or selective voltmeter (including all cables) shall be calibrated according to the procedure defined in this annex. The EUT and the test antenna shall be oriented to obtain the maximum emitted power level. This position shall be recorded in the measurement report. The frequency range shall be measured in this position.

For equipment with multiple fixed beam antennas, the tests shall be carried out with the test antenna oriented to obtain the maximum emitted power level, and repeated for each beam position. If the equipment transmits more than one beam at a time, then the maximum e.i.r.p. shall be recorded.

If the equipment has an antenna which is either mechanically or electronically scanned, then the scanning shall be inhibited for these tests. With the scanning stopped, the e.i.r.p. for the EUT shall be measured with the antenna in its position of highest gain (i.e. highest output power) as stated by the provider.

Measurements of absolute power levels below 40 GHz shall be carried out at a distance of $2d^2/\lambda$. For measurements of absolute power above 40 GHz an anechoic environment or test site is necessary which should be large enough to allow the erection of a test antenna in the far field (i.e. at a distance of not less than $2d^2/\lambda$).

Radiated measurements shall be performed with the EUT in the approved test fixture in a fully anechoic environment.

All radiated measurements with devices operating in the 22,000 GHz to 26,65 GHz band shall be carried out in a fully anechoic environment. For measurements of absolute power the measurement distance shall be large enough to allow the erection of a test antenna in the far field.

For an anechoic chamber the test antenna shall be oriented initially for vertical polarization unless otherwise stated.

B.2 Performance requirements for preamplifier and horn antenna

Table B.1: Minimum performance data for preamplifier and horn antenna

Pre-amplifier	
Parameter	Data
Bandwidth	< 18 GHz to > 28 GHz
Noise figure	< 5 dB
Output at 1 dB compression	> 10 dBm
Gain	> 20 dB
Gain flatness across band	±1,5 dB
Phase response	Linear across frequency range
Impulse response overshoot	< 10 %
Impulse response damping ratio	0,3 to 0,5
VSWR in/out across band	2:1
Nominal impedance	50 Ω
Horn antenna	
Parameter	Data
Gain	> 4 dBi
1 dB bandwidth	< 18 GHz to > 28 GHz
Nominal impedance	50 Ω
VSWR across band	< 1,5:1
Cross polarization	> 20 dB
Front to back ratio	> 20 dB
Tripod mountable	Yes
Robust precision RF connector	Yes
Antenna factors	for 1 m

B.3 Measurement of the residual carrier

The modulation of the SRRs operating according to clause C.1 is realized by pulsing the TX power. Typically, pulsing is done with RF switches that have two operating states, a high isolation and a low insertion loss state. To ensure sufficient suppression of leakage emissions the residual carrier shall be measured. By system concept the residual carrier is always present, therefore the residual carrier average power equals the peak power.

For the measurement according to clause 7.1.4 the device is set into an operating mode where the modulation is shut off and the modulating TX switch is set to its high isolating state, reducing the peak power of the carrier by the switch isolation.

The measurement setup exists of a pick-up horn antenna, a preamplifier and a power-meter. The horn antenna is oriented to obtain the maximum emitted power. Regarding the minimum performance requirements of the preamplifier and the horn antenna clause B.2 applies. The setup shall be calibrated to measure transmitted e.i.r.p. power.

The total radiated power level shall not exceed -10 dBm e.i.r.p. for this test. This assumes an isolation loss of 30 dB. If the isolation loss is different from a value of 30 dB then the radiated power level shall be adjusted accordingly to not exceed the limit of -10 dB.

Annex C (informative): Example of modulation schemes

C.1 Pseudo Noise Pulse Position Modulation (PN PPM)

C.1.1 Definition

For pulse modulation, the Tx "amplitude" is periodically switched on for a short time (called pulse duration pdt) and switched off during the subsequent reception period. A typical example is shown in figure C.1. Due to finite switch isolation, a residual CW emission does occur.

The time between the rising edges of the pulsed output power is called the Pulse Repetition Interval (PRI). The PRI may vary between subsequent pulses, in which case the modulation is called staggered PRI.

In case of a pseudo noise variation of the PRI a wideband spectrum with very homogeneous spectral power density and noise like emissions with respect to narrow band receivers can be achieved.

The Pulse Repetition Frequency (PRF) is the inverse of the PRI averaged over a time sufficiently long to cover all PRI variations.

The pulse duty cycle is the product of the PRF and the pulse duration. The equivalent pulse power duration has to be applied in case of nonrectangular pulse shapes, which is defined to be the duration of an ideal rectangular pulse which has the same content of energy compared with the nonrectangular pulse shape of the EUT.

The radiated power (RMS) on the crest of the pulse shape is called the peak output power.

The peak output power multiplied by the average pulse duty cycle used to generate the broadband spectrum is called the average output power.

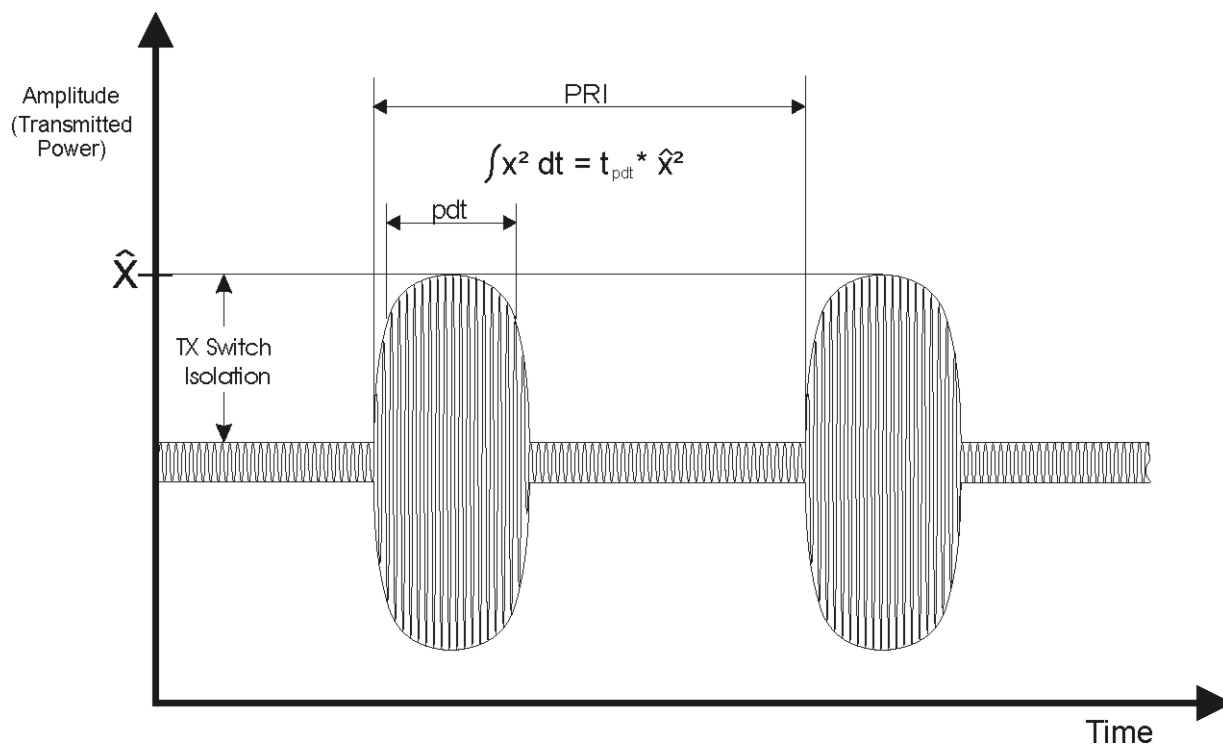

Figure C.1: Typical pulse modulation scheme

C.1.2 Typical operation parameters

The peak and average (RMS) power limits are given in clauses 7.1.2.3 and 7.1.3.4. Typical operation parameters are given in tables C.1 and C.3.

Table C.1: Typical operation parameters for pulse modulation

Parameter	Typical value
PRF	2 MHz
Equivalent pulse power duration	500 ps
Activity factor	10 %
Pulse duty cycle	1/1 000
Residual carrier power	< -10 dBm
Occupied Bandwidth (DSB _{-20 dB})	4 GHz

C.2 Pulsed FH (Pulsed Frequency Hopping)

C.2.1 Definition

For frequency hopping modulation a frequency carrier is stepped over a given frequency bandwidth B_{FH} within frequency slots that are interleaved by the slot interleave bandwidth Δf_i . The coding of the frequency step pattern can be realized with both randomly and predefined sequences at a given hopping frequency f_{hop} . The granularity of the frequency slots determines the spectral distribution, which in case of a pseudo noise randomized sequence of frequency steps, results in a spectrum similar to white noise.

The continuous emission of the FH can be further time gated with a given pulse width T_{pw} (e.g. Pulsed FH). If the pulse repetition frequency PRF is varied over time (staggered PRF), the frequency distribution of the pulsed FH is further dithered over the frequency bandwidth B_{FH} .

With a Staggered Pulse Position Modulated Frequency Hopping system (SPM FH) spread spectrum characteristics can be independently tuned by either varying pulse modulation or frequency slot spreading individually.

For a PPM FH system the number of different hopping frequencies n_{slot} and the pulse width T_{pw} can vary from frame to frame.

In the case of a pure Doppler measurement ($n_{slot} = 1$) the carrier frequency f_{c_norm} has to stay within the 24 GHz SRD band with power levels according to CEPT/ERC/REC 70-03, annex 6 (i.e. 20 dBm peak e.i.r.p. over entire bandwidth). The accumulated dwell time T_{dw} within a frequency slot depends on the pulse width T_{pw} and the hopping frequency f_{hop} in combination with the number of slots during a complete frame time T_{fr} .

Both pulse width T_{pw} and slot changing frequency f_{hop} can be changed within the frame time T_{fr} as long as the peak and average limits in clauses 7.1.2.3 and 7.1.3.4 are respected.

Between consecutive frames there may be a blanking period T_{blk} where no waveform or a constant waveform with the carrier frequency f_{c_norm} located in the 24 GHz SRD band (according to CEPT/ERC/REC 70-03, annex 6 is transmitted).

A typical PM FH modulation is shown in figure C.2.

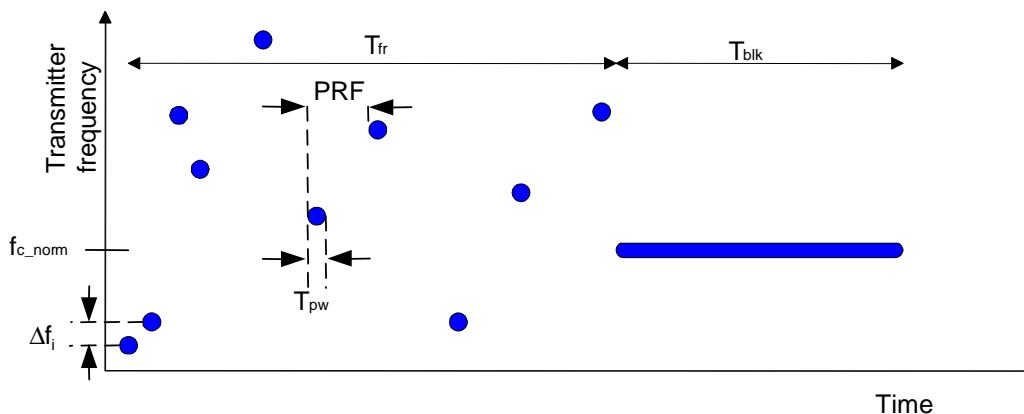

Figure C.2: Typical Pulsed FH modulation

C.2.2 Typical operation parameters

The peak and average (RMS) power limits are given in clauses 7.1.2.3 and 7.1.3.4. Typical operation parameters are given in table C.2.

Table C.2: Typical operation parameters for Pulsed FH modulation

Parameter	Typical value
Number of slots n_{slot} per frame	1 (within SRD band) 2^8 (within B_{FH})
Dwell time per slot T_{dw}	1 μs
Hopping frequency f_{hop}	$1/T_{\text{dw}}$
Frame time period T_{fr}	10 ms
Equivalent pulse power duration T_{pw}	100 ns
Duty cycle for pulse train	10 %
Blank Time period T_{blk}	10 ms
Occupied Bandwidth B_{FH} (DSB -10 dB)	1,5 GHz
slot interleave bandwidth Δf_i	15 MHz

C.2.3 Additional requirements for pulsed FH equipment measurement

C.2.3.1 Pulsed FH modulation

Pulsed FH modulation shall make use of at least 64 well defined, non-overlapping channels or hopping positions separated by the slot interleave bandwidth. The dwell time per frequency hop shall not exceed 10 μs (the instantaneous bandwidth of a single hop channel is defined by the inverse of the pulse width (i.e. a 50 ns pulse modulation generates an instantaneous occupied bandwidth of 20 MHz). While the equipment is operating (transmitting and/or receiving) each channel of the hopping sequence shall be occupied at least once during the frame period.

The provider shall declare the total number of hops, the dwell time, the -20 dB bandwidth per hop and the maximum frequency separation of the individual hops.

C.2.3.2 Measurement requirements

Measurements shall be carried out while the equipment is frequency hopping between the declared occupied bandwidth. The use and the distribution of the individual pulsed frequency hops over the occupied bandwidth shall be declared by the provider and measured accordingly.

C.3 PN-2-PSK (Pseudo noise binary coded phase shift keying)

C.3.1 Definition

With PN-2-PSK modulation, the transmitted continuous wave radiation is modulated in phase by a pseudo noise code, i.e. the direct sequence signal (DSS), that represents the states of the base band signal of a BPSK modulation.

A generic binary DSS impulse $c(t)$ and the corresponding transmitted signal $s(t)$ are shown in figure C.3. The binary DSS impulse $c(t)$ and the transmitted signal $s(t)$ can be expressed as:

$$c(t) = \sum_{i=0}^{L-1} C_i \times u(t - i \times T_c);$$

$$s(t) = c(t) \times \sin(2 \times \pi \times f_c \times t).$$

Where:

C_i defines the states $\{+1, -1\}$ of the elementary signals (chips);

$u(t)$ defines the rectangular signal: $u(t) = \begin{cases} 1 & \text{for } 0 \leq t < T_c \\ 0 & \text{else} \end{cases}$

f_c defines the carrier frequency;

T_c defines the duration of a chip (chip period);

L defines number of chips per PN-sequence.

The bandwidth (B) of the transmitted signal $s(t)$ is defined by the bandwidth of the main lobe and corresponds to twice the inverse of the chip rate, from null to null:

$$B = 2 \times \frac{1}{T_c}$$

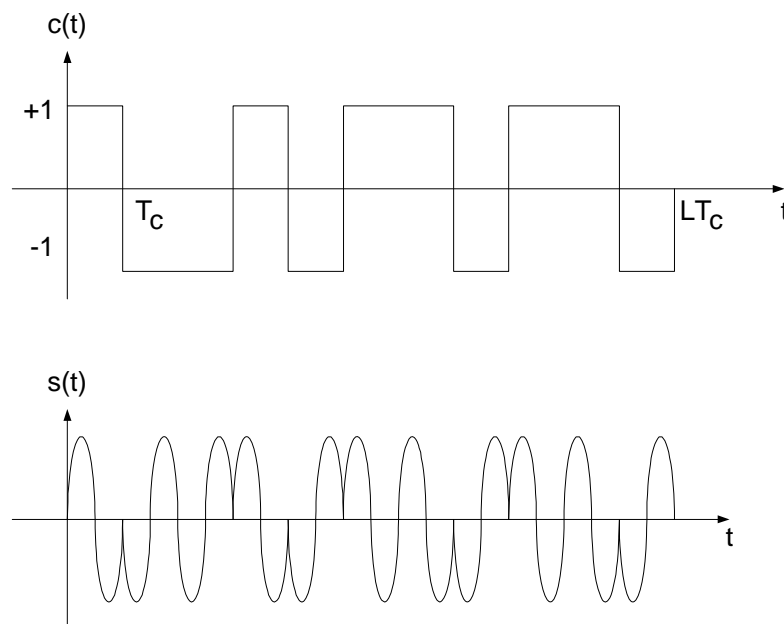

Figure C.3: Typical binary direct sequence impulse $c(t)$ and the transmitted PN-2-PSK signal $s(t)$

The PN-PSK can furthermore be time-gated or pulsed as described in clause C.2.

C.3.2 Typical operation parameters

The peak and average (RMS) power limits are given in clauses 7.1.2.3 and 7.1.3.4. Typical operation parameters are given in table C.3.

Table C.3: Limits for PN-BPSK Modulation

Parameter	Typical value
Chip period T_c	2 ns
PN-sequence period ($L \times T_c$)	10 μ s to 100 μ s
Occupied Bandwidth B (DSB $_{-20\text{ dB}}$)	4 GHz

Annex D (normative): Installation requirements of 24 GHz Short Range Radar (SRR) systems

This annex provides the information for 24 GHz SRR equipment manufacturers and installers to design the equipment and the installation in the road vehicle in such a way, that the essential requirement as stated in EN 302 288-2 [8], clause 4.2.3, are fulfilled.

The following installation requirements shall be fulfilled:

- a) 24 GHz SRR to be installed at a permanent fixed position on a terrestrial transportation vehicle.
- b) The equipment to be operated only when the vehicle is operating, e.g. the car key is in the ignition position.
- c) The mounting height of 24 GHz SRRs to be limited to a maximum of 1,5 m for commercial vehicles (i.e. lorries) and 0,75 m for cars.
- d) The vertical emission limit for transmitter emissions within the frequency range from 23,60 GHz to 24 GHz above an elevation of 30° to be reduced with respect to the bore sight emission at different values with time; -25 dB up to the end of year 2009 and -30 dB at the beginning of the year 2010 (see also clause 7.1.5).
- e) For the protection of Radio Astronomy Sites (RAS), the table D.1 lists radio astronomy site locations and the radius of the exclusion zone for each. Automotive short-range radar equipment put into service in the Community shall ensure protection of the radio astronomy stations operating in the radio spectrum band 22,21 GHz to 24,00 GHz through automatic deactivation in the relevant exclusion zone or via another method providing equivalent protection for these stations without driver intervention. The SRR may be deactivated manually until July 1st, 2007 after which automatic deactivation is mandatory.

Table D.1: List of radio astronomy sites and exclusion zone radii

Country	Name of the station	Geographic Latitude	Geographic Longitude	Exclusion zone radius (km)
Finland	Metsähovi	60°13'04" N	24°23'37" E	7
	Tuorla	60°24'56" N	22°26'31" E	5
France	Plateau de Bure	44°38'01" N	05°54'26" E	35
	Floirac	44°50'10" N	00°31'37" W	35
Germany	Effelsberg	50°31'32" N	06°53'00" E	6,5
Hungary	Penc	47°47'22" N	19°16'53" E	2
Italy	Medicina	44°31'14" N	11°38'49" E	20
	Noto	36°52'34" N	14°59'21" E	8
	Sardinia	39°29'50" N	09°14'40" E	15
Latvia	Ventspils	57°33'12" N	21°51'17" E	8,5
Poland	Kraków – Fort Skala	50°03'18" N	19°49'36" E	1
	Toruń - Piwnice	52°54'48" N	18°33'30" E	1
Russia	Dmitrov	56°26'00" N	37°27'00" E	35
	Kalyazin	57°13'22" N	37°54'01" E	35
	Pushchino	54°49'00" N	37°40'00" E	35
	Zelenchukskaya	43°49'53" N	41°35'32" E	35
Spain	Yebes	40°31'27" N	03°05'22" W	15
	Robledo	40°25'38" N	04°14'57" W	7
Switzerland	Bleien	47°20'26" N	08°06'44" E	3
Sweden	Onsala	57°23'45" N	11°55'35" E	12
UK	Cambridge	52°09'59" N	00°02'20" E	9
	Darnhall	53°09'22" N	02°32'03" W	5
	Jodrell Bank	53°14'10" N	02°18'26" W	9
	Knockin	52°47'24" N	02°59'45" W	5
	Pickmere	53°17'18" N	02°26'38" W	5

Annex E (informative): Conversion of power density to e.i.r.p.

This annex offers an example of the conversion from "power/unit area" (power density) to e.i.r.p.

E.1 Assumptions

e.i.r.p. is the product of "power into the antenna" multiplied by the "antenna gain".

e.i.r.p. is the total power transmitted, assuming an isotropic radiator.

Area of a sphere = πd^2 .

E.2 Example

For a power density of 200 nW/cm² (measured at 3 m):

200 nW/cm² (at 3 m) = power measured in a 1 cm² area at 3 m distance.

e.i.r.p. = total radiated power over the whole area of a sphere.

e.i.r.p. = [power measured in a 1cm² area at 3 m distance (W)] × [area of sphere at 3 m (in cm²)].

e.i.r.p. = [(200 × 10⁻⁹) × (π × 36 × 10⁴)] W.

e.i.r.p. = 226,19 mW.

Hence: 200 nW/cm² (at 3 m) ≅ 23,54 dBm.

Annex F (informative): Bibliography

- ETSI TR 102 273-2 (V1.2.1): "Electromagnetic compatibility and Radio spectrum Matters (ERM); Improvement on Radiated Methods of Measurement (using test site) and evaluation of the corresponding measurement uncertainties; Part 2: Anechoic chamber".
- ETSI EN 301 489-1: "Electromagnetic compatibility and Radio spectrum Matters (ERM); ElectroMagnetic Compatibility (EMC) standard for radio equipment and services; Part 1: Common technical requirements".
- ETSI EN 301 489-3: "Electromagnetic compatibility and Radio spectrum Matters (ERM); ElectroMagnetic Compatibility (EMC) standard for radio equipment and services; Part 3: Specific conditions for Short-Range Devices (SRD) operating on frequencies between 9 kHz and 40 GHz".
- Directive 1999/5/EC of the European Parliament and of the Council of 9 March 1999 on radio equipment and telecommunications terminal equipment and the mutual recognition of their conformity.
- Fotis Karamitsos: "The EU approach to Road Safety and Intelligent Transport Systems (ITS)".

NOTE: See <http://www.cordis.lu>.

- Final report of the e-Safety Working Group on Road Safety.

NOTE: See http://www.europa.eu.int/information_society/programmes/esafety/index_en.htm.

- EC Mandate, Standardization Mandate Forwarded to CEN/CENELEC,/ETSI in the Field of Information Technology And Telecommunication, M/329, Harmonized Standards, covering Ultra Wideband (UWB) Applications.

NOTE: See <http://europa.eu.int/comm/enterprise/rte/harstand.htm>.

- ETSI EN 300 440-1: "Electromagnetic compatibility and Radio spectrum Matters (ERM); Short Range Devices (SRD); Radio equipment to be used in the 1 GHz to 40 GHz frequency range; Part 1: Technical characteristics and test methods".
- CEPT/ERC/REC 70-03: "Relating to the use of Short Range Devices (SRD)".
- Council Recommendation 1999/519/EC of 12 July 1999 on the limitation of exposure of the general public to electromagnetic fields (0 Hz to 300 GHz).
- CEPT/ERC/REC 74-01: "Unwanted emissions in the spurious domain"
- CEPT/ECC/DEC/(04)10: "ECC Decision of 12 November 2004 on the frequency bands to be designated for the temporary introduction of Automotive Short Range Radars (SRR)". (Amended 2005)
- Commission Decision 2005/50/EC of 17 January 2005 on the harmonization of the 24 GHz range radio spectrum band for the time-limited use by automotive short-range radar equipment in the Community.
- CENELEC EN 50371:2002: "Generic standard to demonstrate the compliance of low power electronic and electrical apparatus with the basic restrictions related to human exposure to electromagnetic fields (10 MHz - 300 GHz) - General public".

History

Document history		
V1.1.1	January 2005	Publication
V1.2.1	May 2006	Publication
V1.3.1	April 2007	One-step Approval Procedure OAP 20070810: 2007-04-11 to 2007-08-10
V1.3.1	February 2008	Publication