

Draft **ETSI EN 302 245-2** V1.1.1 (2004-05)

Candidate Harmonized European Standard (Telecommunications series)

**Electromagnetic compatibility
and Radio spectrum Matters (ERM);
Transmitting equipment for the Digital Radio Mondiale (DRM)
broadcasting service;
Part 2: Harmonized EN under article 3.2 of the R&TTE Directive**



Reference

DEN/ERM-TG17WG2-001-2

Keywords

audio, broadcasting, digital, DRM, radio,
regulation, terrestrial, transmitter

ETSI

650 Route des Lucioles
F-06921 Sophia Antipolis Cedex - FRANCE

Tel.: +33 4 92 94 42 00 Fax: +33 4 93 65 47 16

Siret N° 348 623 562 00017 - NAF 742 C
Association à but non lucratif enregistrée à la
Sous-Préfecture de Grasse (06) N° 7803/88

Important notice

Individual copies of the present document can be downloaded from:

<http://www.etsi.org>

The present document may be made available in more than one electronic version or in print. In any case of existing or perceived difference in contents between such versions, the reference version is the Portable Document Format (PDF). In case of dispute, the reference shall be the printing on ETSI printers of the PDF version kept on a specific network drive within ETSI Secretariat.

Users of the present document should be aware that the document may be subject to revision or change of status. Information on the current status of this and other ETSI documents is available at

<http://portal.etsi.org/tb/status/status.asp>

If you find errors in the present document, send your comment to:

editor@etsi.org

Copyright Notification

No part may be reproduced except as authorized by written permission.
The copyright and the foregoing restriction extend to reproduction in all media.

© European Telecommunications Standards Institute 2004.
All rights reserved.

DECT™, **PLUGTESTS™** and **UMTS™** are Trade Marks of ETSI registered for the benefit of its Members.
TIPHON™ and the **TIPHON logo** are Trade Marks currently being registered by ETSI for the benefit of its Members.
3GPP™ is a Trade Mark of ETSI registered for the benefit of its Members and of the 3GPP Organizational Partners.

Contents

Intellectual Property Rights	4
Foreword.....	4
Introduction	5
1 Scope	7
2 References	7
3 Definitions, symbols and abbreviations	8
3.1 Definitions	8
3.2 Symbols.....	9
3.3 Abbreviations	9
4 Technical requirements specifications	9
4.1 Antenna port measurements	9
4.1.1 Spurious emissions	9
4.1.1.1 Definition	9
4.1.1.2 Method of measurement (essential test suite)	9
4.1.1.2.1 Initial conditions	9
4.1.1.2.2 Procedure.....	10
4.1.1.2.3 Test requirements	10
4.1.1.3 Limit.....	10
4.1.2 Out-of-band emissions.....	11
4.1.2.1 Definition	11
4.1.2.2 Method of measurement (essential test suite)	11
4.1.2.2.1 Initial conditions	11
4.1.2.2.2 Procedure.....	11
4.1.2.2.3 Test requirements	11
4.1.2.3 Limit.....	11
4.1.3 Transmitter muting during frequency shift	13
4.1.3.1 Definition	13
4.1.3.2 Method of measurement.....	14
4.1.3.2.1 Initial conditions	14
4.1.3.2.2 Procedure.....	14
4.1.3.2.3 Test requirements	14
4.1.3.3 Limit.....	14
4.2 Enclosure port measurements (radiated emissions).....	14
4.2.1 Cabinet radiation.....	14
4.2.1.1 Definition	14
4.2.1.2 Method	14
4.2.1.2.1 Initial conditions	14
4.2.1.2.2 Procedure.....	15
4.2.1.2.3 Test requirements	15
4.2.1.3 Limits	15
4.3 Measurement uncertainties	16
Annex A (normative): General measuring arrangements	17
A.1 Testing arrangements for antenna port and enclosure port measurements.....	17
A.1.1 Test frequency range (antenna port measurements)	17
A.1.2 Testing arrangement	18
History	19

Intellectual Property Rights

IPRs essential or potentially essential to the present document may have been declared to ETSI. The information pertaining to these essential IPRs, if any, is publicly available for **ETSI members and non-members**, and can be found in ETSI SR 000 314: "*Intellectual Property Rights (IPRs); Essential, or potentially Essential, IPRs notified to ETSI in respect of ETSI standards*", which is available from the ETSI Secretariat. Latest updates are available on the ETSI Web server (<http://webapp.etsi.org/IPR/home.asp>).

Pursuant to the ETSI IPR Policy, no investigation, including IPR searches, has been carried out by ETSI. No guarantee can be given as to the existence of other IPRs not referenced in ETSI SR 000 314 (or the updates on the ETSI Web server) which are, or may be, or may become, essential to the present document.

Foreword

This Candidate Harmonized European Standard (Telecommunications series) has been produced by ETSI Technical Committee Electromagnetic compatibility and Radio spectrum Matters (ERM), and is now submitted for the Public Enquiry phase of the ETSI standards Two-step Approval Procedure.

The present document is part 2 of a multi-part deliverable covering the Transmitting equipment for the Digital Radio Mondiale (DRM) broadcasting service, as identified below:

Part 1: "Technical characteristics and test methods";

Part 2: "Harmonized EN under article 3.2 of the R&TTE Directive".

The present document has been produced by ETSI in response to a mandate from the European Commission issued under Council Directive 98/34/EC [11] laying down a procedure for the provision of information in the field of technical standards and regulations.

The present document is intended to become a Harmonized Standard, the reference of which will be published in the Official Journal of the European Communities referencing the Directive 1999/5/EC [1] of the European Parliament and of the Council of 9 March 1999 on radio equipment and telecommunications terminal equipment and the mutual recognition of their conformity ("the R&TTE Directive").

Proposed national transposition dates	
Date of latest announcement of this EN (doa):	3 months after ETSI publication
Date of latest publication of new National Standard or endorsement of this EN (dop/e):	6 months after doa
Date of withdrawal of any conflicting National Standard (dow):	18 months after doa

Introduction

The present document is part of a set of standards designed to fit in a modular structure to cover all radio and telecommunications terminal equipment under the R&TTE Directive [1]. Each standard is a module in the structure. The modular structure is shown in figure 1.

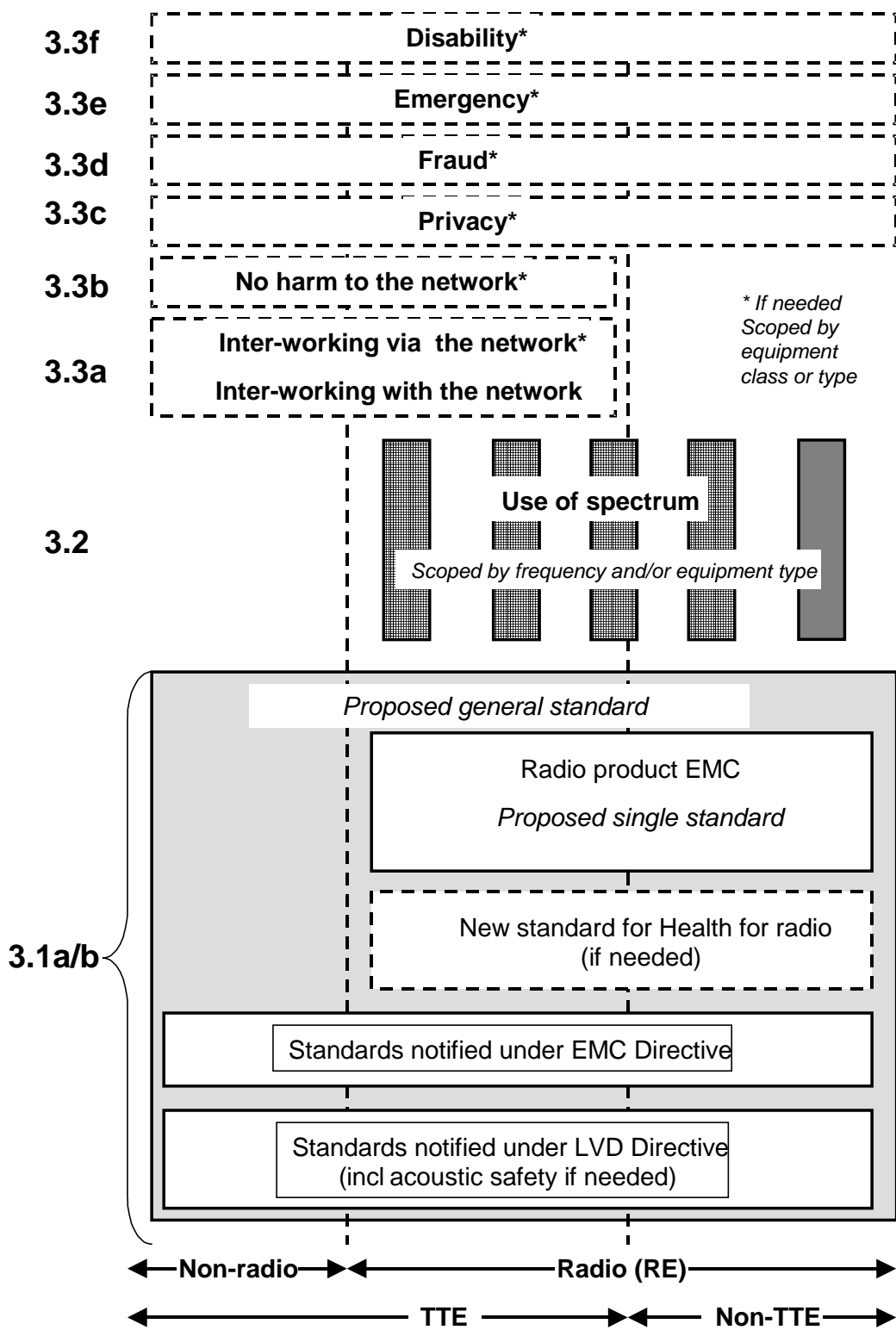

Figure 1: Modular structure for the various standards used under the R&TTE Directive

The left hand edge of the figure 1 shows the different clauses of Article 3 of the R&TTE Directive [1].

For article 3.3 various horizontal boxes are shown. Dotted lines indicate that at the time of publication of the present document essential requirements in these areas have to be adopted by the Commission. If such essential requirements are adopted, and as far and as long as they are applicable, they will justify individual standards whose scope is likely to be specified by function or interface type.

The vertical boxes show the standards under article 3.2 for the use of the radio spectrum by radio equipment. The scopes of these standards are specified either by frequency (normally in the case where frequency bands are harmonized) or by radio equipment type.

For article 3.1b the diagram shows the new single multi-part product EMC standard for radio, and the existing collection of generic and product standards currently used under the EMC Directive [2]. The parts of this new standard will become available in the second half of 2000, and the existing separate product EMC standards will be used until it is available.

For article 3.1a the diagram shows the existing safety standards currently used under the LV Directive [4] and new standards covering human exposure to electromagnetic fields. New standards covering acoustic safety may also be required.

The bottom of the figure shows the relationship of the standards to radio equipment and telecommunications terminal equipment. A particular equipment may be radio equipment, telecommunications terminal equipment or both. A radio spectrum standard will apply if it is radio equipment. An article 3.3 standard will apply as well only if the relevant essential requirement under the R&TTE Directive [1] is adopted by the Commission and if the equipment in question is covered by the scope of the corresponding standard. Thus, depending on the nature of the equipment, the essential requirements under the R&TTE Directive [1] may be covered in a set of standards.

The modularity principle has been taken because:

- it minimizes the number of standards needed. Because equipment may, in fact, have multiple interfaces and functions it is not practicable to produce a single standard for each possible combination of functions that may occur in an equipment;
- it provides scope for standards to be added:
 - under article 3.2 when new frequency bands are agreed; or
 - under article 3.3 should the Commission take the necessary decisionswithout requiring alteration of standards that are already published;
- it clarifies, simplifies and promotes the usage of Harmonized Standards as the relevant means of conformity assessment.

1 Scope

The present document applies to Transmitting equipment for the Digital Radio Mondiale (DRM) broadcasting service.

The types of equipment covered by the present document are as follows:

- Transmitting equipment for the Digital Radio Mondiale broadcasting service operating in the harmonized LF, MF and HF terrestrial sound broadcasting bands.

The present document is intended to cover the provisions of Article 3.2, of Directive 1999/5/EC [1] (R&TTE Directive), which states that "... radio equipment shall be so constructed that it effectively uses the spectrum allocated to terrestrial/space radio communications and orbital resources so as to avoid harmful interference."

In addition to the present document, other ENs that specify technical requirements in respect of essential requirements under other parts of Article 3 of the R&TTE Directive [1] may apply to equipment within the scope of the present document.

NOTE: A list of such ENs is included on the web site <http://www.newapproach.org>.

2 References

The following documents contain provisions which, through reference in this text, constitute provisions of the present document.

- References are either specific (identified by date of publication and/or edition number or version number) or non-specific.
- For a specific reference, subsequent revisions do not apply.
- For a non-specific reference, the latest version applies.

Referenced documents which are not found to be publicly available in the expected location might be found at <http://docbox.etsi.org/Reference>.

- [1] Directive 1999/5/EC of the European Parliament and of the Council of 9 March 1999 on radio equipment and telecommunications terminal equipment and the mutual recognition of their conformity (R&TTE Directive).
- [2] Council Directive 89/336/EEC of 3 May 1989 on the approximation of the laws of the Member States relating to electromagnetic compatibility (EMC Directive).
- [3] Council Directive 73/23/EEC of 19 February 1973 on the harmonization of the laws of the Member States relating to electrical equipment designed for use within certain voltage limits (LV Directive).
- [4] International Telecommunication Union (ITU): "Radio regulations", Edition 2001.
- [5] CENELEC EN 55011: "Industrial, scientific and medical (ISM) radio-frequency equipment - Radio disturbance characteristics - Limits and methods of measurement", Definitions, symbols and abbreviations.
- [6] ETSI EN 302 245-1: "Electromagnetic compatibility and Radio spectrum Matters (ERM); Transmitting equipment for the Digital Radio Mondiale (DRM) broadcasting service; Part 1: Technical characteristics and test methods".
- [7] ETSI EN 301 489-11: "Electromagnetic compatibility and Radio spectrum Matters (ERM); ElectroMagnetic Compatibility (EMC) standard for radio equipment and services; Part 11: Specific conditions for terrestrial sound broadcasting service transmitters".
- [8] ETSI TR 100 028: "Electromagnetic compatibility and Radio spectrum Matters (ERM); Uncertainties in the measurement of mobile radio equipment characteristics".

- [9] ETSI ES 201 980: "Digital Radio Mondiale (DRM) System Specification".
- [10] CENELEC EN 55022: "Limits and methods of measurement of radio disturbance characteristics of information technology equipment".
- [11] Council directive 98/34/EC of the European Parliament and of the Council of 22 June 1998 laying down a procedure for the provision of information in the field of technical standards and regulations.

3 Definitions, symbols and abbreviations

3.1 Definitions

For the purposes of the present document, the following terms and definitions apply:

broadcasting service: radiocommunication service in which the transmissions are intended for direct reception by the general public. This service may include sound transmissions, television transmissions or other types of transmission

channel bandwidth: frequency band of defined width (as a multiple of the carrier grid) including safety margin for operation on adjacent channels, located symmetrically around a carrier frequency in the carrier grid

class of emission: set of characteristics of an emission, designated by standard symbols, e.g. type of modulation of the main carrier, modulating signal, type of information to be transmitted, and also, if appropriate, any additional signal characteristics

dBc: decibels relative to the unmodulated carrier power of the emission

NOTE: In the cases which do not have a carrier, for example in some digital modulation schemes where the carrier is not accessible for measurement, the reference level equivalent to dBc is decibels relative to the mean power P.

enclosure port: physical boundary of the apparatus through which electromagnetic fields may radiate or impinge

NOTE: In the case of integral antenna equipment, this port is inseparable from the antenna port.

environmental profile: range of environmental conditions under which equipment within the scope of EN 302 245-2 is required to comply with the provisions of EN 302 245-2

harmonic: component of order greater than 1 of the Fourier series of a periodic quantity

harmonic number: integral number given by the ratio of the frequency of a harmonic to the fundamental frequency (2nd harmonic = 2 x fundamental frequency)

mean power: average power supplied to the antenna transmission line by a transmitter during an interval of time sufficiently long compared with the lowest frequency encountered in the modulation envelope taken under normal operating conditions

necessary bandwidth: for a given class of emission, the width of the frequency band which is sufficient to ensure the transmission of information at the rate and with the quality required under specified conditions

out-of-band emissions: emission on a frequency or frequencies immediately outside the necessary bandwidth which results from the modulation process, but excluding spurious emissions

reference bandwidth: bandwidth in which the emission levels are specified

spurious emissions: emission on a frequency or frequencies which are outside the necessary bandwidth and the level of which may be reduced without affecting the corresponding transmission of information. Spurious emissions include harmonic emissions, parasitic emissions, intermodulation products and frequency conversion products but exclude out of band emissions

unwanted emissions: consist of spurious emissions and out of band emissions

3.2 Symbols

For the purposes of the present document, the following symbol applies:

μ micro (10^{-6})

3.3 Abbreviations

For the purposes of the present document, the following abbreviations apply:

AF	Audio Frequency
DRM	Digital Radio Mondiale
EMC	Electro-Magnetic Compatibility
emf	electromotive force
EUT	Equipment Under Test
HF	High Frequency
LF	Low Frequency
LV	Low Voltage
MF	Medium Frequency
R&TTE	Radio and Telecommunications Terminal Equipment

4 Technical requirements specifications

4.1 Antenna port measurements

4.1.1 Spurious emissions

4.1.1.1 Definition

Emission on a frequency or frequencies which are outside the necessary bandwidth and the level of which may be reduced without affecting the corresponding transmission of information. Spurious emissions include harmonic emissions, parasitic emissions, intermodulation products and frequency conversion products but exclude out of band emissions [4].

4.1.1.2 Method of measurement (essential test suite)

4.1.1.2.1 Initial conditions

Test environment:

- the normal operating environment, as declared by the equipment manufacturer.

Test frequencies:

- 1) the lowest operating frequency of the EUT;
- 2) the highest operating frequency of the EUT;
- 3) a frequency mid-way between 1) and 2) above.

Test arrangement (see figure A.1):

- 1) all ports unused at the time of testing shall be correctly terminated;
- 2) connect the EUT to the test load, via the coupling device;
- 3) connect the measuring device to the coupling device (a filter may be used to attenuate the wanted signal).

4.1.1.2.2 Procedure

- 1) Operate the EUT at each of the test frequencies as defined in clause 4.1.1.2.1.
- 2) Measure the results on the spectrum analyser.

4.1.1.2.3 Test requirements

The results obtained shall be compared to the limits in clause 4.1.1.3 in order to demonstrate compliance.

4.1.1.3 Limit

Spurious emissions shall not exceed the values set out in table 4.1 and additionally figure 4.1 for the frequency range 9 kHz to 1 GHz.

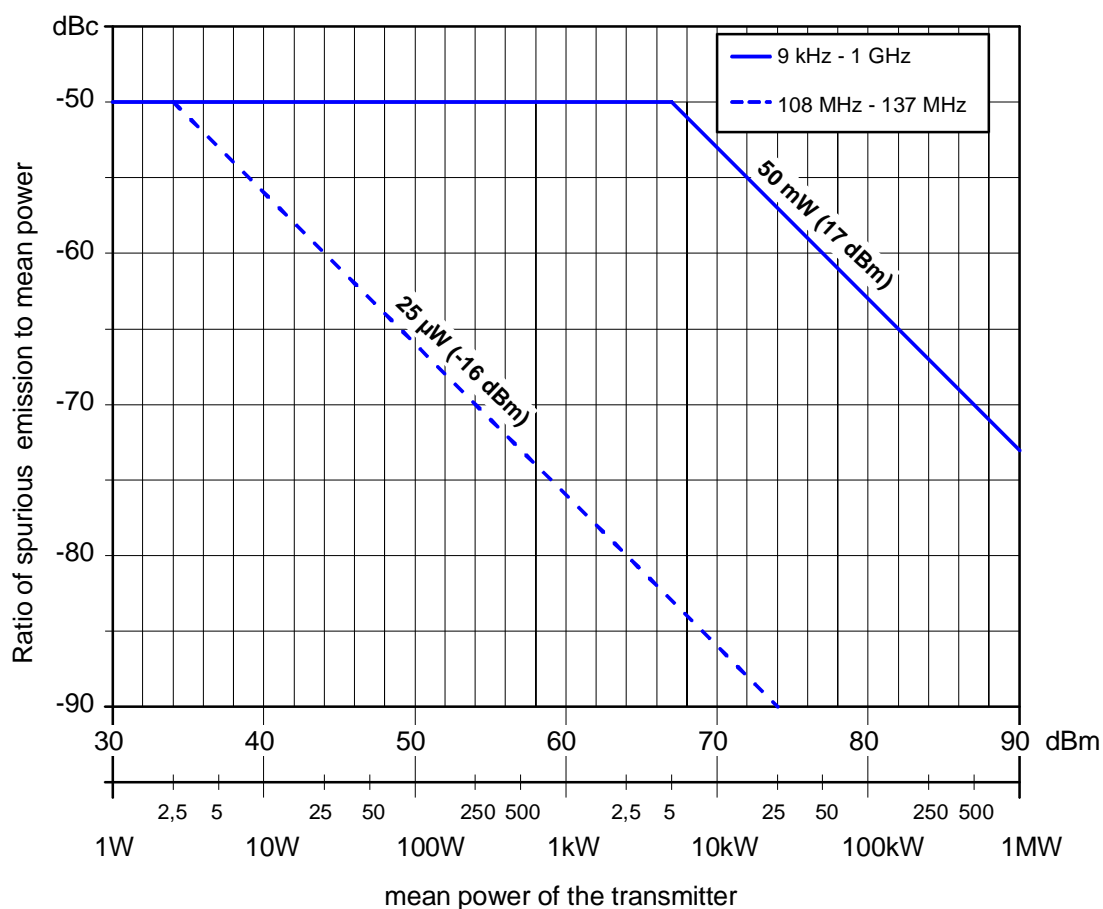

Figure 4.1: Spurious emission limits

Table 4.1: Spurious emission limits for DRM sound broadcasting transmitters

Limits	
Mean power of the transmitter	Mean power absolute levels (dBm) or relative levels (dBc) below the mean power supplied to the antenna port in the reference bandwidth (see annex A)
All power ranges	-50 dBc, without exceeding the absolute mean power of 50 mW (17 dBm)
NOTE:	Within the band 108 MHz to 137 MHz the limits shall be -50 dBc, without exceeding the absolute mean power of 25 µW (-16 dBm).

4.1.2 Out-of-band emissions

4.1.2.1 Definition

Out-of-band emissions are defined as any emission on a frequency or frequencies immediately outside the necessary bandwidth which results from the modulation process, but excluding spurious emissions. For the purposes of the present document the out-of-band region shall extend to ± 500 % of the necessary bandwidth.

4.1.2.2 Method of measurement (essential test suite)

4.1.2.2.1 Initial conditions

Test environment:

- the normal operating environment, as declared by the equipment manufacturer.

Test frequencies:

- 1) the lowest operating frequency of the EUT;
- 2) the highest operating frequency of the EUT;
- 3) a frequency mid-way between 1) and 2) above.

Test arrangement:

- see figure A.2.

4.1.2.2.2 Procedure

- 1) All ports unused at the time of testing shall be correctly terminated.
- 2) Operate the EUT at each of the test frequencies as defined in clause 4.1.2.2.1.
- 3) Measure the results on the spectrum analyser.

4.1.2.2.3 Test requirements

The results obtained shall be compared to the limits in clause 4.1.2.3 in order to demonstrate compliance.

4.1.2.3 Limit

The limits shown in table 4.2 and additionally shown in table 4.3 and figures 4.2 and 4.3 apply.

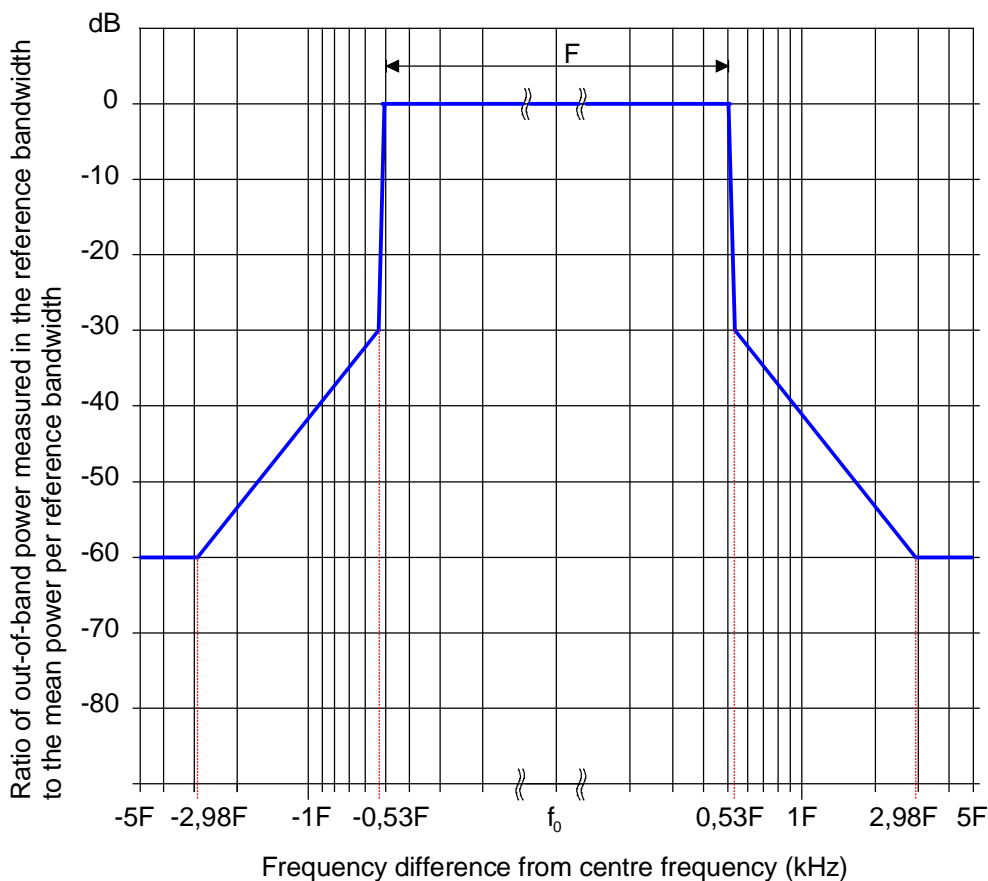

Figure 4.2: Out-of-band emission limits shown on a logarithmic axis

Table 4.2: Out-of-band emission limits (logarithmic axis)

Relative Frequency (f/F)	Effective Frequency (f) at different nominal bandwidth or occupied channel bandwidth (F) (kHz)						Out-of-band emission limits (dB)
	F = 4,5	F = 5	F = 9	F = 10	F = 18	F = 20	
±0,10	0,45	0,50	0,90	1,00	1,80	2,00	0,00
±0,50	2,25	2,50	4,50	5,00	9,00	10,00	0,00
±0,53	2,39	2,65	4,77	5,30	9,54	10,60	-30,00
±2,98	13,41	14,90	26,82	29,80	53,64	59,60	-60,00
±5	22,5	25	45	50	90	100	-60,00

NOTE: The slope between 0,5 F and 0,53 F is 30 dB. The slope outside 0,53 F is 12 dB per octave until the value of -60 dB is reached.

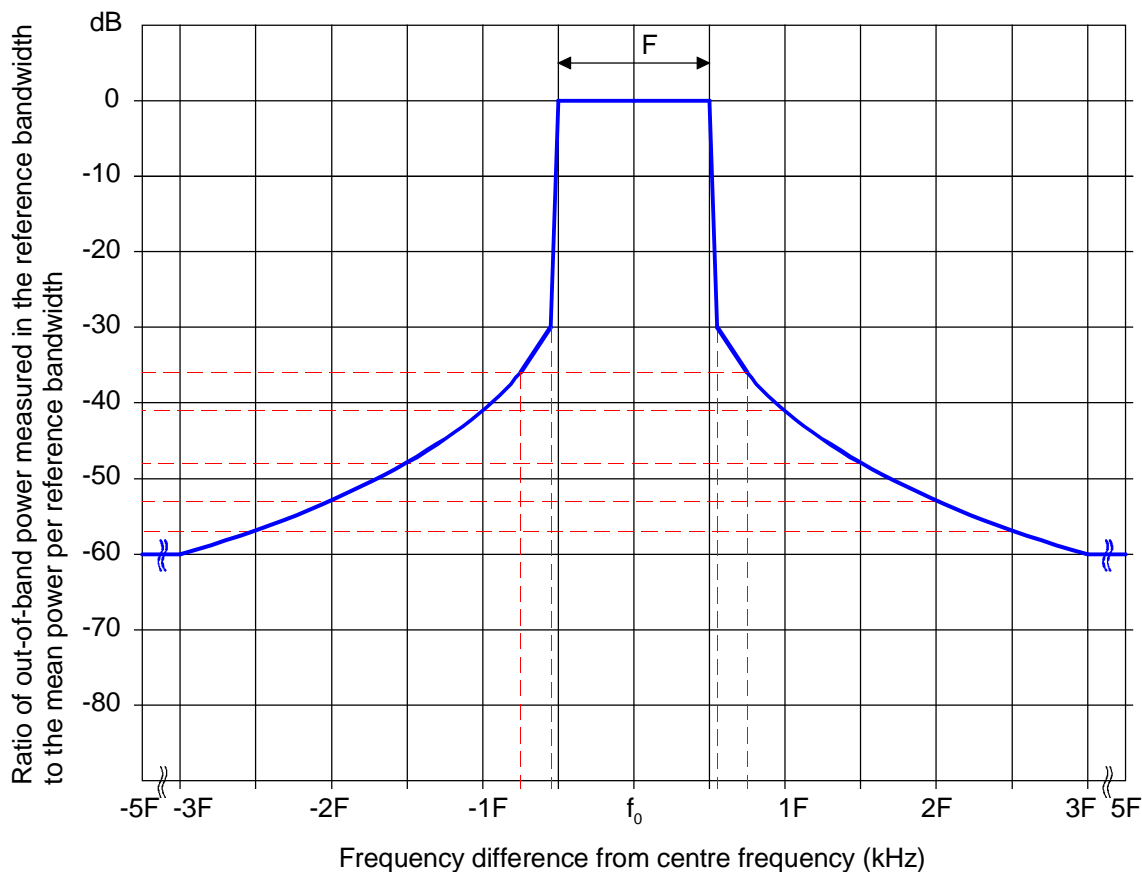

Figure 4.3: Out-of-band emission limits shown on a linear axis

Table 4.3: Out-of-band emission limits (linear axis)

Relative Frequency (f/F)	Effective Frequency (f) at different nominal bandwidth or occupied channel bandwidth (F) (kHz)						Out-of-band emission limits (dB)
	F = 4,5	F = 5	F = 9	F = 10	F = 18	F = 20	
$\pm 0,10$	0,45	0,50	0,90	1,00	1,80	2,00	0,00
$\pm 0,50$	2,25	2,50	4,50	5,00	9,00	10,00	0,00
$\pm 0,53$	2,39	2,65	4,77	5,30	9,54	10,60	-30,00
$\pm 0,75$	3,38	3,75	6,75	7,50	13,50	15,00	-36,03
$\pm 1,00$	4,50	5,00	9,00	10,00	18,00	20,00	-41,03
$\pm 1,50$	6,75	7,50	13,50	15,00	27,00	30,00	48,07
$\pm 2,00$	9,00	10,00	18,00	20,00	36,00	40,00	53,07
$\pm 2,50$	11,25	12,5	22,50	25,00	45,00	50,00	56,95
$\pm 2,98$	13,41	14,90	26,82	29,80	53,64	59,60	-60,00
± 5	22,5	25	45	50	90	100	-60,00

4.1.3 Transmitter muting during frequency shift

4.1.3.1 Definition

The suppression of emissions during the re-tuning of transmitters.

4.1.3.2 Method of measurement

4.1.3.2.1 Initial conditions

Test environment:

- the normal operating environment, as declared by the equipment manufacturer.

Test frequencies:

- present frequency to desired frequency.

Test arrangement (see figure A.1):

- 1) all ports unused at the time of testing shall be correctly terminated;
- 2) connect the EUT to the test load, via the coupling device;
- 3) connect the measuring device to the coupling device.

4.1.3.2.2 Procedure

- 1) Operate the EUT at the present frequency.
- 2) Initiate frequency change.
- 3) Observe the output signal on an oscilloscope.

4.1.3.2.3 Test requirements

The results obtained shall be compared to the limits in clause 4.1.3.3 in order to demonstrate compliance.

4.1.3.3 Limit

The muting shall be as defined in clause 4.1.1.3.

4.2 Enclosure port measurements (radiated emissions)

4.2.1 Cabinet radiation

4.2.1.1 Definition

Emissions from the equipment, radiated from the enclosure port, other than those present at the antenna port.

4.2.1.2 Method

4.2.1.2.1 Initial conditions

Test environment:

- the normal operating environment, as declared by the equipment manufacturer.

Test frequencies:

- a) the lowest operating frequency of the EUT;
- b) the highest operating frequency of the EUT;
- c) a frequency mid-way between a) and b) above.

Test arrangement:

- see figure A.1.

4.2.1.2.2 Procedure

The test method shall be in accordance with EN 55022 [10], unless physical size is a restriction, in which case the test method shall be in accordance with EN 55011 [5].

- Measurements shall be made in the operational mode producing the largest emission in the frequency band being investigated consistent with normal applications.
- The equipment shall be configured in a manner which is representative of a normal/typical operation, where practical.
- An attempt shall be made to maximize the detected radiated emission, e.g. by moving the cables of the equipment.
- The configuration and mode of operation during measurements shall be precisely noted in the test report.
- All input/output ports shall be correctly terminated.
- The tests shall be carried out at a point within the specified normal operating environmental range and at the rated supply voltage for the equipment.

4.2.1.2.3 Test requirements

The results obtained shall be compared to the limits in clause 4.2.1.3 in order to demonstrate compliance.

4.2.1.3 Limits

Cabinet radiation shall not exceed the values set out in table 4.4, shown additionally in figure 4.4.

This test shall be performed at a distance of 10 m, where feasible. When size and/or power requirements necessitate testing in a manufacturing facility, other distances may be used (see notes 1, 2 and 3).

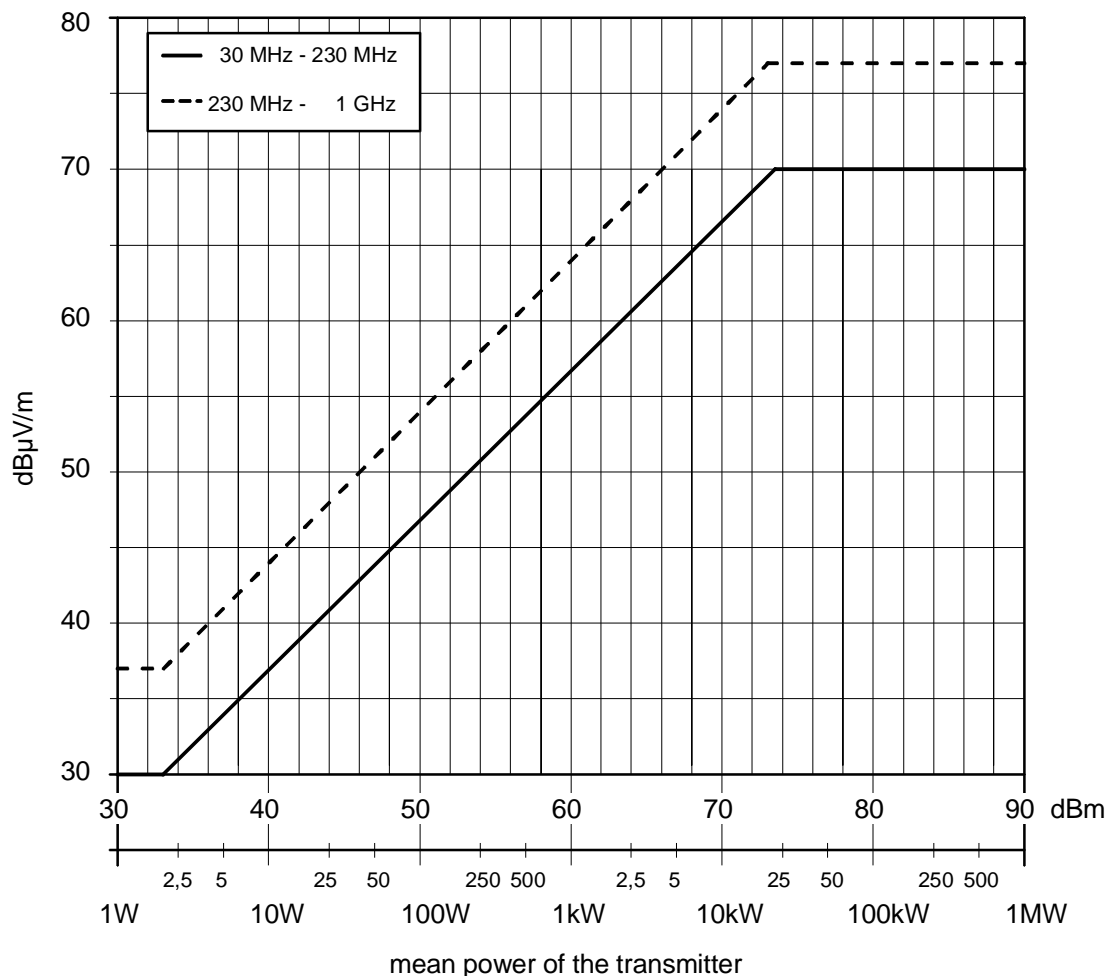

Figure 4.4: Cabinet radiation for DRM transmitters

Table 4.4

Limits for radiated emissions	
Quasi-peak limits (dBµV/m) at 10 m (see note)	Frequency range
$30 \text{ dB}\mu\text{V/m} \leq 60 + 10 \log_{10} (P_0 / 2\,000) \leq 70 \text{ dB}\mu\text{V/m}$	30 MHz to 230 MHz
$37 \text{ dB}\mu\text{V/m} \leq 67 + 10 \log_{10} (P_0 / 2\,000) \leq 77 \text{ dB}\mu\text{V/m}$	> 230 MHz to 1 GHz
NOTE: P_0 = RF output power in watts.	

NOTE 1: The measurements can be carried out at other distances. In that case limits are modified according to the relation:

$$L(x\text{m}) = L(10\text{m}) + 20 \log (10/x);$$

where x = distance.

NOTE 2: Care should be taken if measuring at test distances below 10 m as this may be in the near field.

NOTE 3: In cases of dispute the measurement distance of 10 m shall take precedence.

4.3 Measurement uncertainties

Measurement uncertainty should be calculated and techniques employed to minimize its range. This uncertainty should be applied to the limit and any measurement falling below the range is deemed acceptable [8].

Annex A (normative): General measuring arrangements

A.1 Testing arrangements for antenna port and enclosure port measurements

A.1.1 Test frequency range (antenna port measurements)

Limits on unwanted emissions for radio equipments are considered to be applicable to the range 9 kHz to 300 GHz. However, for practical measurement purposes, the frequency range of spurious emissions may be restricted. As guidance for practical purposes, the following measurement parameters in table A.1 are recommended:

Table A.1: Antenna port measurements

Transmitter fundamental frequency range	Unwanted Emission frequency measurement range	
	Lower frequency	Upper frequency
9 kHz to 30 MHz	9 kHz	1 GHz

The following reference bandwidths are to be used:

For spurious emissions:

- 1 kHz between 9 kHz and 150 kHz;
- 10 kHz between 150 kHz and 30 MHz;
- 100 kHz between 30 MHz and 1 GHz.

For out of band emissions:

- 100 Hz.

A.1.2 Testing arrangement

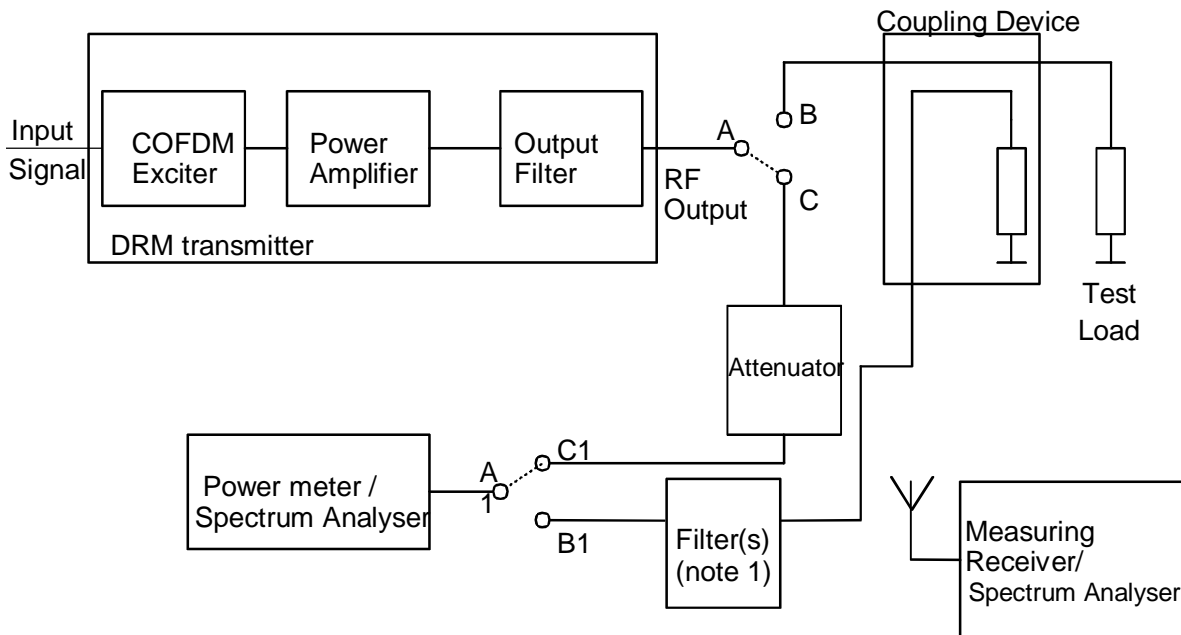

NOTE 1: Filter(s) not used in Rated output power measurements.

NOTE 2: For high power transmitters the preferred set up would require A to be connected to B and A1 to be connected to B1.

NOTE 3: For low power transmitters the preferred set up would require A to be connected to C and A1 to be connected to C1.

NOTE 4: For enclosure port measurements the "Measuring Receiver / Spectrum Analyser" is used to measure the results.

Figure A.1: Testing arrangement

History

Document history			
V1.1.1	May 2004	Public Enquiry	PE 20040910: 2004-05-12 to 2004-09-10