

Final draft **ETSI EN 302 195-1** V1.1.1 (2004-01)

European Standard (Telecommunications series)

**Electromagnetic compatibility
and Radio spectrum Matters (ERM);
Radio equipment in the frequency range 9 kHz to 315 kHz
for ultra low power active medical implants and accessories;
Part 1: Technical characteristics and test methods**



Reference

DEN/ERM-TG30-001-1

Keywords

health, inductive, magnetic, mobile, radio, short range, SRD, testing

ETSI

650 Route des Lucioles
F-06921 Sophia Antipolis Cedex - FRANCE

Tel.: +33 4 92 94 42 00 Fax: +33 4 93 65 47 16

Siret N° 348 623 562 00017 - NAF 742 C
Association à but non lucratif enregistrée à la
Sous-Préfecture de Grasse (06) N° 7803/88

Important notice

Individual copies of the present document can be downloaded from:

<http://www.etsi.org>

The present document may be made available in more than one electronic version or in print. In any case of existing or perceived difference in contents between such versions, the reference version is the Portable Document Format (PDF). In case of dispute, the reference shall be the printing on ETSI printers of the PDF version kept on a specific network drive within ETSI Secretariat.

Users of the present document should be aware that the document may be subject to revision or change of status. Information on the current status of this and other ETSI documents is available at

<http://portal.etsi.org/tb/status/status.asp>

If you find errors in the present document, send your comment to:

editor@etsi.org

Copyright Notification

No part may be reproduced except as authorized by written permission.
The copyright and the foregoing restriction extend to reproduction in all media.

© European Telecommunications Standards Institute 2004.
All rights reserved.

DECTTM, **PLUGTESTS**TM and **UMTS**TM are Trade Marks of ETSI registered for the benefit of its Members.
TIPHONTM and the **TIPHON logo** are Trade Marks currently being registered by ETSI for the benefit of its Members.
3GPPTM is a Trade Mark of ETSI registered for the benefit of its Members and of the 3GPP Organizational Partners.

Contents

Intellectual Property Rights	6
Foreword.....	6
1 Scope	7
2 References	8
3 Definitions, symbols and abbreviations	8
3.1 Definitions	8
3.2 Symbols.....	9
3.3 Abbreviations	9
4 Technical requirements specifications	10
4.1 General requirements	10
4.1.1 Receiver classification	10
4.1.2 General performance criteria	10
4.2 Presentation of equipment for testing purposes.....	10
4.2.1 Choice of model for testing	11
4.2.2 Testing of equipment that does not have an external 50 Ω RF connector (integral antenna equipment)	11
4.2.2.1 Equipment with an internal permanent or temporary antenna connector.....	11
4.2.2.2 Equipment with a temporary antenna connector.....	11
4.3 Mechanical and electrical design.....	11
4.3.1 General.....	11
4.3.2 Controls	11
4.3.3 Transmitter shut-off facility	11
4.3.4 Receiver power save capability	12
4.4 Declarations by the applicant	12
4.5 Auxiliary test equipment	12
4.6 Interpretation of the measurement results	12
5 Test conditions, power sources and ambient temperatures	12
5.1 Normal and extreme test conditions	12
5.2 Test power source.....	12
5.2.1 External test power source.....	13
5.2.2 Internal test power source	13
5.3 Normal test conditions.....	13
5.3.1 Normal temperature and humidity.....	13
5.3.2 Normal test power source	13
5.3.2.1 Mains voltage.....	13
5.3.2.2 Regulated lead-acid battery power sources	14
5.3.2.3 Other power sources.....	14
5.4 Extreme test conditions	14
5.4.1 Extreme temperatures	14
5.4.1.1 Procedure for tests at extreme temperatures.....	14
5.4.1.1.1 Procedure for equipment designed for continuous operation	14
5.4.1.1.2 Procedure for equipment designed for intermittent operation	14
5.4.1.2 Extreme temperature ranges.....	15
5.4.2 Extreme test source voltages.....	15
5.4.2.1 Mains voltage.....	15
5.4.2.2 Regulated lead-acid battery power sources	15
5.4.2.3 Power sources using other types of batteries.....	16
5.4.2.4 Other power sources.....	16
6 General conditions.....	16
6.1 Normal test signals and test modulation.....	16
6.1.1 Normal test signals for data	16
6.2 Antenna	17
6.2.1 Artificial Antenna	17

6.3	Test fixture	17
6.3.1	Alternate test fixture for equipment intended to be implanted within a human body	17
6.4	Test sites and general arrangements for radiated measurements	18
6.5	Modes of operation of the transmitter	18
6.6	Measuring receiver	18
7	Transmitter requirements	18
7.1	Transmitter definitions	19
7.1.1	The inductive loop coil transmitters	19
7.1.2	Product classes	19
7.2	Transmitter carrier output levels	20
7.2.1	H-field (radiated)	20
7.2.1.1	Definition	20
7.2.1.2	Methods of measurement	20
7.2.1.3	Limits	20
7.2.2	Radiated E-field	20
7.2.2.1	Definition	21
7.2.2.2	Methods of measurement	21
7.2.2.3	Limits	21
7.3	Permitted frequency range of the modulation bandwidth	21
7.3.1	Definition	21
7.3.2	Method of measurement	21
7.3.3	Limits	22
7.4	Spurious emissions	22
7.4.1	Definition	22
7.4.2	Radiated field strength	22
7.4.2.1	Methods of measurement (< 30 MHz)	22
7.4.2.2	Limits	23
7.5	Duty cycle	23
7.5.1	Definitions	23
7.5.2	Declaration	23
7.5.3	Duty cycle classes	23
8	Receiver requirement	24
8.1	Blocking or desensitization	24
8.1.1	Definition	24
8.1.2	Methods of measurement	24
8.1.3	Limits	25
8.2	Receiver spurious radiation	25
8.2.1	Definition	25
8.2.1.1	Methods of measurement	25
8.2.1.2	Limits	25
9	Measurement uncertainty	26
Annex A (normative): Radiated measurements		27
A.1	Test sites and general arrangements for measurements involving the use of radiated fields	27
A.1.1	Outdoor test site	27
A.1.1.1	Standard position	28
A.1.1.2	Equipment in close proximity to the human body but external to it	28
A.1.1.3	Active medical implant equipment	28
A.1.2	Test antenna	30
A.1.2.1	Below 30 MHz	30
A.1.3	Optional additional indoor site	30
A.2	Guidance on the use of radiation test sites	30
A.2.1	Measuring distance	30
A.2.2	Auxiliary cables	31
Annex B (normative): H-field limit correction factor for generated E-fields		32
Annex C (informative): E-fields in the near field at low frequencies		33

Annex D (normative):	H-field measurements at other distances than 10 m.....	34
Annex E (informative):	Bibliography.....	36
History		37

Intellectual Property Rights

IPRs essential or potentially essential to the present document may have been declared to ETSI. The information pertaining to these essential IPRs, if any, is publicly available for **ETSI members and non-members**, and can be found in ETSI SR 000 314: "*Intellectual Property Rights (IPRs); Essential, or potentially Essential, IPRs notified to ETSI in respect of ETSI standards*", which is available from the ETSI Secretariat. Latest updates are available on the ETSI Web server (<http://webapp.etsi.org/IPR/home.asp>).

Pursuant to the ETSI IPR Policy, no investigation, including IPR searches, has been carried out by ETSI. No guarantee can be given as to the existence of other IPRs not referenced in ETSI SR 000 314 (or the updates on the ETSI Web server) which are, or may be, or may become, essential to the present document.

Foreword

This European Standard (Telecommunications series) has been produced by ETSI Technical Committee Electromagnetic compatibility and Radio spectrum Matters (ERM), and is now submitted for the Vote phase of the ETSI standards Two-step Approval Procedure.

For non-EU countries the present document may be used for regulatory (Type Approval) purposes.

The present document is part 1 of a multi-part deliverable covering inductively coupled Ultra Low Power Active Medical Implants (ULP-AMI) devices in the frequency range 9 kHz to 315 kHz, as identified below:

Part 1: "Technical characteristics and test methods";

Part 2: "Harmonized EN covering essential requirements of article 3.2 of the R&TTE Directive".

Proposed national transposition dates	
Date of latest announcement of this EN (doa):	3 months after ETSI publication
Date of latest publication of new National Standard or endorsement of this EN (dop/e):	6 months after doa
Date of withdrawal of any conflicting National Standard (dow):	6 months after doa

1 Scope

The present document applies to Ultra Low Power Active Medical Implant (ULP-AMI) transmitters and receivers operating in the range from 9 kHz to 315 kHz and any associated radio apparatus transmitting in the frequency range of 9 kHz to 315 kHz including external programmers and patient related telecommunication devices using digital modulation techniques such as, but not limited to, FSK or pulse position modulation. Analogue voice modulation is not within the scope of the present document.

The present document contains the technical characteristics and test methods for radio equipment and is referenced in CEPT/ECC Recommendation 70-03 [2], annex 12 band(b).

The present document does not necessarily include all the characteristics which may be required by a user, nor does it necessarily represent the optimum performance achievable. It is a product standard which may be completely or partially superseded by specific standards covering specific applications.

The present document applies to ULP-AMI transceivers conforming to the following:

- inductive loop systems;
- with an antenna connection and/or with an integral antenna;
- for use as telecommunications and telecommand transmission to/from active medical implants.

ULP-AMI equipment has an inherent safety of human life implication, manufacturers and users are cautioned to pay particular attention to the potential for interference from other systems operating in the same or adjacent bands.

The present document covers physician operated programmer/controllers transmitters (typically fixed stations), patient operated external transmitters (fixed or mobile stations) and implanted radio transmitting devices (portable stations).

All types of digital modulation for radio devices are covered by the present document.

The radio equipment, covered by the classification SRD is divided into several power classes based on maximum radiated field strength or output power (see table 1). The power class designation is based on CEPT/ERC Recommendation 70-03 [2] and ERC Decisions.

Table 1: Maximum radiated H-field

Power Class	Radiated H-field or power level
1	7 dB μ A/m at 10 m
2	42 dB μ A/m at 10 m
3	72 dB μ A/m at 10 m (at 9 kHz to 30 kHz, descending 3 dB/octave from 30 kHz to 135 kHz)
4	37,7 dB μ A/m at 10 m (at 135 kHz, descending 3 dB/octave from 135 kHz to 1 MHz)
	29 dB μ A/m at 10 m (at 1,0 MHz descending 9 dB/octave from 1 MHz to 4,642 MHz)
5	9 dB μ A/m at 10 m (4,642 MHz to 30 MHz)
	30 dB μ A/m at 10 m 9 kHz to 315 kHz

2 References

The following documents contain provisions which, through reference in this text, constitute provisions of the present document.

- References are either specific (identified by date of publication and/or edition number or version number) or non-specific.
- For a specific reference, subsequent revisions do not apply.
- For a non-specific reference, the latest version applies.

Referenced documents which are not found to be publicly available in the expected location might be found at <http://docbox.etsi.org/Reference>.

- [1] Directive 1999/5/EC of the European Parliament and of the Council of 9 March 1999 on radio equipment and telecommunications terminal equipment and the mutual recognition of their conformity (R&TTE Directive).
- [2] CEPT/ERC Recommendation 70-03: "Relating to the use of Short Range Devices (SRD)".
- [3] ITU-T Recommendation O.153: "Basic parameters for the measurement of error performance at bit rates below the primary rate".
- [4] ETSI ETR 028: "Radio Equipment and Systems (RES); Uncertainties in the measurement of mobile radio equipment characteristics".
- [5] Air Force Technical Report AL/OE-TR-1996-0037: "Compilation of the Dielectric Properties of Body Tissues at RF and Microwave Frequencies ".

3 Definitions, symbols and abbreviations

3.1 Definitions

For the purposes of the present document, the following terms and definitions apply:

active medical implant: diagnostic or therapeutic device designed to be implanted in a human body containing a power source and capable of generating radio frequency energy within the 9 kHz to 315 kHz frequency band for the purpose of providing a digital communications link

artificial antenna: tuned reduced-radiating dummy load equal to the nominal impedance specified by the applicant

assigned frequency: frequency within the applicable band on which the device is authorized to operate

conducted measurements: measurements which are made using a direct connection to the equipment under test

custom antenna: antenna built according to manufacturers antenna design rules

dedicated antenna: removable antenna supplied and tested with the radio equipment that is designed as an indispensable part of the equipment

fixed station: equipment intended for use in a fixed location

H-field test antenna: electrically screened loop or equivalent antenna, with which the magnetic component of the field can be measured

integral antenna: permanent fixed antenna, which may be built-in, that is designed as an indispensable part of the equipment

magnetic dipole moment: product of (Number of coil turns) × (coil area) × (coil current)

NOTE: Air coils only.

medical implant device: apparatus that includes a transmitter with an integral receiver that operates in the ULP-AMI band that is placed inside the human body for the purpose of performing diagnostic functions and/or delivery of therapeutic treatment

medical implant programmer/control transmitter: a transmitter, operating outside of a human body in the ULP-AMI frequency band that transfers information to/from the implant after a communications link is initiated

mobile station: equipment external to the body, normally used by a patient, to provide telecommand or telemetry communication functions to a medical implant device placed within the body

patient activator: equipment intended to be used by a patient to communicate with an implanted device

portable station: equipment intended to be carried, attached or implanted in a human body that is operated at a separation distance less than 20 cm from or internal to a human body

programmer/controller: ULP-AMI equipment used by a physician to communicate with an implanted device

radiated measurements: measurements which involve the absolute measurement of a radiated field

telecommand: use of radio communication for the transmission of signals to initiate, modify or terminate functions of equipment at a distance

telecommunications: use of radio communications for the transmission of data between various ULP-AMI devices

telemetry: use of radio communication for indicating or recording data at a distance

ultra low power active medical implant (ULP-AMI): active medical implant transmitter or associated medical implant programmer/control transmitter that is designed to radiate RF energy in accordance with the provisions of annex 12, band (b), to CEPT/ECC Recommendation 70-03 [2] and EN 302 195-1

3.2 Symbols

For the purposes of the present document, the following symbols apply:

E	Electrical field strength
E _o	Reference electrical field strength (see annex A)
f	frequency
H	Magnetic field strength
H _o	Reference magnetic field strength (see annex A)
m	magnetic dipole moment
P	Power
R	Distance
R _o	Reference distance (see annex A)
t	time

3.3 Abbreviations

For the purposes of the present document, the following abbreviations apply:

EMC	ElectroMagnetic Compatibility
RF	Radio Frequency
R&TTE	Radio and Telecommunications Terminal Equipment
SRD	Short Range Device
ULP-AMI	Ultra Low Power - Active Medical Implant

4 Technical requirements specifications

4.1 General requirements

4.1.1 Receiver classification

The product family of ULP-AMI radio devices is divided into three Equipment Classes, see table 2, each having its own set of minimum performance criteria. This classification is based upon the impact on persons in case the equipment does not operate above the specified minimum performance level. Applicable equipment classification shall be specified by the manufacturer.

Table 2

Receiver class	Relevant receiver clauses	Risk assessment of receiver performance
1	8.1 and 8.2	Highly reliable ULP-AMI communication media; e.g. serving human life inherent systems (may result in a physical risk to a person)
2	8.1 and 8.2	Medium reliable ULP-AMI communication media e.g. causing Inconvenience to persons, which cannot simply be overcome by other means
3	8.2	Standard reliable ULP-AMI communication media e.g. Inconvenience to persons, which can simply be overcome by other means (e.g. manual)
NOTE: In particular where an ULP-AMI which may have an inherent safety of human life implication, manufacturers and users should pay particular attention to the potential for interference from other systems operating in the same or adjacent bands.		

4.1.2 General performance criteria

The receiver performance shall be in conformity with the specifications declared by the manufacturer. Where the intended performance cannot be achieved under testing, the manufacturer shall declare and publish the performance criteria used to determine the performance of the receiver.

4.2 Presentation of equipment for testing purposes

Each equipment submitted for testing where type approval is still in force shall fulfil the requirements of the present document on all frequencies over which it is intended to operate.

The applicant shall declare the operating frequency, the range of operating conditions and power requirements in consultation with the accredited laboratory, as applicable, to establish the appropriate test conditions.

Additionally, technical documentation and operating manuals, sufficient to make the test, shall be supplied.

A test fixture for equipment with an integral antenna may be supplied by the applicant (see clause 6.3). For equipment supplied with an external antenna the applicant shall provide the antenna and a suitable test fixture as needed. In general, compliance must be shown by performing radiated magnetic field strength measurements.

If an equipment is designed to operate with different radiated field strengths or power level, measurement of each transmitter parameter shall be performed, according to the present document, on samples of equipment defined in clause 4.2.1.

To simplify and harmonize the testing procedures between different testing laboratories, measurements shall be performed, according to the present document, on samples defined in clause 4.2.1.

4.2.1 Choice of model for testing

The applicant shall provide one or more samples of the equipment, as appropriate for testing.

Stand alone equipment shall be offered by the applicant complete with any ancillary equipment needed for testing.

If an equipment has several optional features, considered not to affect the RF parameters then the tests need only to be performed on the equipment configured with that combination of features considered to be the most complex, as proposed by the applicant and agreed by the test laboratory.

In the case of integral or dedicated antenna equipment, if the equipment does not have an internal permanent 50 Ω connector then it is permissible to supply a second sample of the equipment with a temporary antenna connector fitted to facilitate testing, see clause 4.2.2.

4.2.2 Testing of equipment that does not have an external 50 Ω RF connector (integral antenna equipment)

This type of equipment will normally be tested by performing radiated tests at 10 m. For devices with very low radiated field levels, measurements may be made at closer distance and the levels extrapolated to 10 m using the procedures in annex E.

4.2.2.1 Equipment with an internal permanent or temporary antenna connector

The means to access and/or implement the internal permanent or temporary antenna connector shall be stated by the applicant with the aid of a diagram. The fact that use has been made of the internal antenna connection, or of a temporary connection, to facilitate measurements shall be recorded in the test report.

4.2.2.2 Equipment with a temporary antenna connector

The applicant may submit one set of equipment with the normal antenna connected, to enable radiated measurements to be made. The applicant shall attend the test laboratory at the conclusion of the radiated measurements, to disconnect the antenna and fit the temporary connector if needed. The testing laboratory staff shall not connect or disconnect any temporary antenna connector.

Alternatively, the applicant may submit two sets of equipment to the test laboratory, one fitted with a temporary antenna connector with the antenna disconnected and another equipment with the antenna connected. Each equipment shall be used for the appropriate tests. The applicant shall declare that the two sets of equipment are identical in all aspects except for the antenna connector.

4.3 Mechanical and electrical design

4.3.1 General

The equipment submitted by the applicant should be designed, constructed and manufactured in accordance with sound engineering practice and with the aim of minimizing harmful interference to other equipment and services.

Transmitters and receivers may be individual or combination units.

4.3.2 Controls

Those controls which, if maladjusted, might increase the interfering potentialities of the equipment should not be easily accessible to the user.

4.3.3 Transmitter shut-off facility

If the transmitter is equipped with an automatic transmitter shut-off facility, it should be made inoperative for the duration of the test.

4.3.4 Receiver power save capability

If the receiver is equipped with a battery-saving circuit, this circuit should be made inoperative for the duration of the tests.

4.4 Declarations by the applicant

When submitting equipment for type testing, the applicant shall supply the necessary information required by the appropriate application form.

The performance of the equipment submitted for type testing shall be representative of the performance of the corresponding production model.

4.5 Auxiliary test equipment

All necessary test signal sources, test fixtures, specialized test apparatus and set-up information shall accompany the equipment when it is submitted for type testing unless alternative arrangements are agreed to by the test house and the manufacturer.

4.6 Interpretation of the measurement results

The interpretation of the results recorded on the appropriate test report for the measurements described in the present document shall be as follows:

- the measured value, determined by extrapolation if needed, relating to the corresponding limit shall be used to decide whether an equipment meets the requirements of the present document;
- the measurement uncertainty value for the measurement of each parameter shall be included in the test report;
- the recorded value of the measurement uncertainty shall, for each measurement, be equal to, or lower than, the figures in the table of measurement uncertainty (clause 9).

5 Test conditions, power sources and ambient temperatures

5.1 Normal and extreme test conditions

Type testing shall be made under normal test conditions, and also, where stated, under extreme test conditions. It should be noted that emissions test on active medical implant devices may at the option of the manufacturer be performed using the human torso simulator filled with the tissue substitute material at nominal room temperature. The purpose is to facilitate testing at the measurement facility. Measured emission levels are not expected to vary significantly from the levels measured at the nominal temperature of 37°C.

The test conditions and procedures shall be as specified in clauses 5.2 to 5.4.

5.2 Test power source

The equipment shall be tested using the appropriate test power source as specified in clauses 5.2.1 or 5.2.2. Where equipment can be powered using either external or internal power sources, then the equipment shall be tested using the external power source as specified in clause 5.2.1 then repeated using the internal power source as specified in clause 5.2.2.

The test power source used shall be stated in the test report.

5.2.1 External test power source

During type tests, the power source of the equipment shall be replaced by an external test power source capable of producing normal and extreme test voltages as specified in clauses 5.3.2 and 5.4.2. The internal impedance of the external test power source shall be low enough for its effect on the test results to be negligible. For the purpose of the tests, the voltage of the external test power source shall be measured at the input terminals of the equipment. The external test power source shall be suitably de-coupled as close to the equipment battery terminals as practicable. For radiated measurements any external power leads should be so arranged so as not to affect the measurements.

During tests the test power source voltages shall be within a tolerance of $< \pm 1$ % relative to the voltage at the beginning of each test. The value of this tolerance can be critical for certain measurements. Using a smaller tolerance will provide a better uncertainty value for these measurements.

5.2.2 Internal test power source

For radiated measurements on portable equipment with integral antenna, fully charged internal batteries should be used. The batteries used should be as supplied or recommended by the applicant. If internal batteries are used, at the end of each test the voltage shall be within a tolerance of $< \pm 5$ % relative to the voltage at the beginning of each test. For portable devices where the batteries cannot be measured or replaced but have telemetry readout of battery voltage, it is acceptable to record the starting and ending voltages as provided by the telemetry readout. This shall be stated in the test report.

If appropriate, for conducted measurements or where a test fixture is used, an external power supply at the required voltage may replace the supplied or recommended internal batteries. This shall be stated on the test report.

For equipment intended to be implanted in a human body that is hermetically sealed it may not be possible to measure the battery voltage directly or indirectly. For this type of equipment, it is not necessary to measure the voltage at the end of each test; however, care shall be taken to ensure that the internal battery supply voltage does not fall below the manufacturer's specification for normal operating voltage range. For battery operated devices, it is acceptable to read the battery voltage via telemetry readout.

5.3 Normal test conditions

5.3.1 Normal temperature and humidity

The normal temperature and humidity conditions for tests for devices external to the human body shall be any convenient combination of temperature and humidity within the following ranges:

- temperature +15°C to +37°C;
- relative humidity 20 % to 75 %.

Active medical implant transmitters operate after implant in a human body. Accordingly, the body tends to serve as an oven to maintain the implant temperature near 37°C. Therefore, the normal temperature and humidity conditions for implant transmitters shall be within the following ranges:

- temperature +36°C to +38°C;
- relative humidity not applicable.

When it is impracticable to carry out tests under these conditions, a note to this effect, stating the ambient temperature and relative humidity during the tests, shall be added to the test report.

5.3.2 Normal test power source

5.3.2.1 Mains voltage

The normal test voltage for equipment to be connected to the mains shall be the nominal mains voltage. For the purpose of the present document, the nominal voltage shall be the declared voltage, or any of the declared voltages, for which the equipment was designed.

The frequency of the test power source corresponding to the ac mains shall be between 49 Hz and 51 Hz.

5.3.2.2 Regulated lead-acid battery power sources

When the radio equipment is intended for operation with the usual types of regulated lead-acid battery power source, the normal test voltage shall be 1,1 multiplied by the nominal voltage of the battery (e.g. 6 V, 12 V, etc.).

5.3.2.3 Other power sources

For operation from other power sources or types of battery (primary or secondary), the normal test voltage shall be that declared by the equipment applicant and agreed by the accredited test laboratory. Such values shall be stated in the test report.

5.4 Extreme test conditions

5.4.1 Extreme temperatures

5.4.1.1 Procedure for tests at extreme temperatures

Before measurements are made the equipment shall have reached thermal balance in the test chamber. The equipment shall be switched off during the temperature stabilizing period.

In the case of equipment containing temperature stabilization circuits designed to operate continuously, the temperature stabilization circuits shall be switched on for 15 minutes after thermal balance has been obtained, and the equipment shall then meet the specified requirements.

If the thermal balance is not checked by measurements, a temperature stabilizing period of at least one hour, or such period as may be decided by the accredited test laboratory, shall be allowed. The sequence of measurements shall be chosen, and the humidity content in the test chamber shall be controlled so that excessive condensation does not occur.

If the equipment is incapable of transmitting an unmodulated carrier, an actual digital data sequence or a pseudorandom sequence representative of an actual digital data transmission shall be used to modulate the carrier (see clauses 6.1 and 6.1.1).

5.4.1.1.1 Procedure for equipment designed for continuous operation

If the applicant states that the equipment is designed for continuous operation, the test procedure shall be as follows:

- before conducting tests at the upper extreme temperature the equipment shall be placed in the test chamber and left until thermal balance is attained. The equipment shall then be switched on in the transmit condition for a period of time specified by the manufacturer to be the maximum time the equipment will transmit in normal operation after which the equipment shall meet the specified requirements;
- for tests at the lower extreme temperature, the equipment shall be left in the test chamber until thermal balance is attained, then switched on for a period of one minute after which the equipment shall meet the specified requirements.

5.4.1.1.2 Procedure for equipment designed for intermittent operation

If the applicant states that the equipment is designed for intermittent operation, the test procedure shall be as follows:

- before tests at the upper extreme temperature the equipment shall be placed in the test chamber and left until thermal balance is attained in the oven. The equipment shall then either:
 - transmit on and off according to the applicants declared duty cycle for a period of five minutes; or
 - if the applicant's declared on period exceeds one minute, then transmit in the on condition for a period not exceeding one minute, followed by a period in the off or standby mode for four minutes; after which the equipment shall meet the specified requirements;

- for tests at the lower extreme temperature, the equipment shall be left in the test chamber until thermal balance is attained, then switched to the standby or receive condition for one minute after which the equipment shall meet the specified requirements.

5.4.1.2 Extreme temperature ranges

For tests at extreme temperatures, measurements shall be made in accordance with the procedures specified in clause 5.4.1.1, at the upper and lower temperatures of one of the following ranges.

Table 3: Extreme temperature ranges

Category I (General)	-20°C to +55°C
Category II (Portable equipment for outdoor use)	-10°C to +55°C
Category III (Equipment for normal indoor use) (see note 1)	0°C to +55°C
Category IV (Active Medical Implant transmitters) (see note 2)	+25°C to +45°C
NOTE 1: The term "equipment for normal indoor use" is taken to mean that the room temperature is controlled and the minimum indoor temperature is equal to or greater than 5°C.	
NOTE 2: The term "Active Medical Implant transmitters" refers only to equipment that is intended to be placed inside a human body during normal operation. The range of +25°C to +45°C is the core body temperature variation over which a human body can survive.	

The manufacturer may define a different temperature range than specified above for any category provided the EUT meets the conditions set forth below. For specific applications, the manufacturer can specify wider temperature ranges than given as a minimum above. In this case the test report shall show compliance with the limits in the present document over the extended ranges specified by the manufacturer. This shall be reflected in the manufacturers' product literature. Narrower temperature ranges than given above may be implemented provided the reduced range is reflected in the manufacturers' product literature and the test report shows that the device implements techniques which do not allow it to exceed the limits specified in the present document over the minimum ranges given above.

The equipment shall comply with all the technical requirements of the present document at all times when operating within the boundary limits of the required operational temperature profile.

For special applications, the manufacturer can specify wider temperature ranges than given as a minimum above. This shall be reflected in manufacturers' product literature.

The test report shall state which range is used.

5.4.2 Extreme test source voltages

5.4.2.1 Mains voltage

The extreme test voltages for equipment to be connected to an ac mains source shall be the nominal mains voltage $\pm 10\%$. For equipment operating over a range of mains voltages clause 5.4.2.4 applies.

5.4.2.2 Regulated lead-acid battery power sources

When the radio equipment is intended for operation from the usual type of regulated lead-acid battery power sources the extreme test voltages shall be 1,3 and 0,9 multiplied by the nominal voltage of the battery (6 V, 12 V, etc.).

For float charge applications using "gel-cell" type batteries the extreme voltage shall be 1,15 and 0,85 multiplied by the nominal voltage of the declared battery voltage.

5.4.2.3 Power sources using other types of batteries

The lower extreme test voltages for equipment with power sources using batteries shall be as follows:

- for equipment with a battery indicator, the end point voltage as indicated;
- for equipment without a battery indicator the following end point voltages shall be used:
 - a) for the Leclanché or the lithium type of battery:
 - 0,85 multiplied by the nominal voltage of the battery;
 - b) for the nickel-cadmium type of battery:
 - 0,9 multiplied the nominal voltage of the battery;
- for other types of battery or equipment, the lower extreme test voltage for the discharged condition shall be declared by the equipment applicant.

The nominal voltage is considered to be the upper extreme test voltage in this case.

5.4.2.4 Other power sources

For equipment using other power sources, or capable of being operated from a variety of power sources, the extreme test voltages shall be according to manufactures specification.

6 General conditions

The following clauses are written to define conditions for individual units to be separately tested. However, it is not intended to prevent a "system approach" to performing the testing where each individual unit in a given system will be operational during testing. Where individual units have differing requirements, the test report shall list and identify the unit separately together with the information showing compliance with the applicable requirement.

6.1 Normal test signals and test modulation

The test modulating signal is a signal which modulates a carrier, is dependent upon the type of equipment under test and also the measurement to be performed. Modulation test signals only apply to products with an external modulation connector. For equipment without an external modulation connector, normal operating modulation shall be used.

6.1.1 Normal test signals for data

Normal test signals for data are specified as follows:

- D-M2: a test signal representing a pseudo-random bit sequence of at least 511 bits in accordance with ITU-T Recommendation O.153 [3]. This sequence shall be continuously repeated. If the sequence cannot be continuously repeated, the actual method used shall be stated in the test report.
- D-M3: a test signal shall be agreed between the accredited test laboratory and the applicant in case selective messages are used and are generated or decoded within the equipment.
The agreed test signal may be formatted and may contain error detection and correction.

For angle modulation, the normal level of the test signal D-M3 shall produce a deviation of 20 % of the channel separation or any other value as declared by the applicant as the normal operating level.

In case of amplitude modulation, the modulation ratio shall be 60 %, or any value, as declared by the applicant, as the normal operating level.

For other forms of modulation, the ratio and level will be as declared by the applicant.

6.2 Antenna

Equipment operating in the 9 kHz to 315 kHz band shall have an integral antenna, an external dedicated antenna or both. If provision for an external antenna connection is made, the connector shall be a unique type to prevent use of an antenna other than a dedicated antenna supplied by the manufacturer.

6.2.1 Artificial Antenna

An artificial antenna that simulates the actual antenna configuration specified by the applicant may be used only as necessary. The test laboratory and the manufacturer shall agree as to the arrangement.

6.3 Test fixture

With equipment intended for use with an integral antenna, and not equipped with a 50 Ω RF output connector, a suitable test fixture may be used as agreed with the accredited test laboratory, if radiated measurements with the intended antenna cannot be made.

This fixture is a RF coupling device for coupling the integral antenna to a 50 Ω RF terminal at the working frequencies of the equipment under test. This allows certain measurements to be performed using conducted measuring methods. However, only relative measurements may be performed. The test fixture is normally only required for extreme temperature measurements and shall be calibrated only with the equipment under test.

The test fixture shall be fully described by the applicant. The accredited test laboratory, where applicable shall calibrate the test fixture by carrying out the required field measurements at normal temperatures at the prescribed test site. Then the same measurements shall be repeated on the equipment under test using the test fixture for all identified frequency components.

In addition, the test fixture may provide:

- a connection to an external power supply;
- a connection to a data interface.

The performance characteristics of the test fixture shall be agreed upon with the accredited test laboratory, where applicable and shall conform to the following basic parameters:

- the circuit associated with the RF coupling shall contain no active or non linear devices;
- the coupling loss shall not influence the measuring results;
- the coupling loss shall be independent of the position of the test fixture and be unaffected by the proximity of the surrounding objects or people;
- the coupling loss shall be reproducible when the equipment under test is removed and replaced;
- the coupling loss shall remain substantially constant when the environmental conditions are varied.

6.3.1 Alternate test fixture for equipment intended to be implanted within a human body

For measurement purposes, to determine compliance with all emission limits, active medical implants may be tested in a fixture that approximates the physical conditions of an implant transmitter placed in a human body. This fixture, a human torso simulator, with the implant mounted inside, shall be filled with a tissue substitute material and placed on the radiated emissions test site turntable with the implant at a height of 1,5 m above the ground plane for testing purposes. The tissue substitute material conductivity and dielectric parameters shall in accordance with clause A.1.1.3. Typically they will be equivalent to those of human muscle tissue at the fundamental frequency or alternatively these parameters may be adjusted to correspond to the measurement frequency. The tissue substitute material shall be sufficiently fluid that it will flow around the implant without creating any voids.

6.4 Test sites and general arrangements for radiated measurements

For guidance on radiation test sites, see annex A. Detailed descriptions of radiated measurement arrangements are included in this annex.

6.5 Modes of operation of the transmitter

For the purpose of the measurements according to the present document, there should preferably be a facility to operate the transmitter in an unmodulated state. The method of achieving an unmodulated carrier frequency or special types of modulation patterns may also be decided by agreement between the applicant and the accredited test laboratory. It shall be described in the test report. It may involve suitable temporary internal modifications of the equipment under test. If it is not possible to provide an unmodulated carrier then this shall be stated in the test report.

For the purpose of type testing, the normal test signal, see clauses 6.1 and 6.1.1, shall be applied to the input of the transmitter under test with the normal input device disconnected when possible.

6.6 Measuring receiver

The term "measuring receiver" refers to a selective voltmeter or a spectrum analyser. The bandwidth and detector type of the measuring receiver are given in table 4. Measurements above 30 MHz are not required.

Table 4

Frequency (f)	Detector type	Bandwidth
$9 \text{ kHz} \leq f < 150 \text{ kHz}$	Quasi Peak	200 Hz to 300 Hz
$150 \text{ kHz} \leq f < 30 \text{ MHz}$	Quasi Peak	9 kHz to 10 kHz

Exceptionally, a different bandwidth may be used for narrow band signals if agreed with the accredited test laboratory. This shall be stated in the test report.

7 Transmitter requirements

To meet the requirements of the present document, the transmitter shall be measured at the radiated H-field, conducted current or power level as declared by the applicant.

Where the transmitter is designed with an adjustable carrier H-field or RF current, all parameters shall be measured using the highest output level as declared by the applicant. The equipment shall then be adjusted to the lowest setting, as declared by the applicant, and the spurious emissions measurement shall be repeated (see clause 7.4).

When making transmitter tests on equipment designed for intermittent operation, the duty cycle of the transmitter, as declared by the applicant on the application form, shall not be exceeded. The actual duty cycle used shall be stated on the test report form.

If the equipment is supplied with an integral antenna and a permanent antenna connector to be used with a dedicated antenna, the following full tests shall be carried out using the integral antenna and the dedicated antenna connected to the external connector:

- radiated H-field (see clause 7.2.1);
- radiated E-field (see clause 7.2.2);
- spurious emissions (see clause 7.4).

7.1 Transmitter definitions

Transmitters covered by the present document are considered to have internal and/or dedicated external antennas. In this case, radiated field strength measurements are required. User defined antenna systems are not permitted.

7.1.1 The inductive loop coil transmitters

These transmitters are characterized by:

- a) the loop coil antenna area A shall be $< 30 \text{ m}^2$;
- b) the length of any antenna loop element shall be $< \frac{\lambda}{4}$ ($< \frac{75}{f}$, where f is in MHz) or $< 30 \text{ m}$ whichever is shorter;
- c) antenna coil may have one or multiple turns.

7.1.2 Product classes

This equipment is defined as Product Class 1 or Product Class 2. The Product Class shall not be confused with Equipment Class, see clause 4.1.1 or with Power Class, see clauses 1 and 7.2.1.3. The different antenna types are referencing CEPT/ERC Recommendation 70-03 [2].

Product Class 1:

Inductive loop coil transmitter, tested with an antenna as either:

- an integral antenna (antenna type 1); or
- a dedicated antenna supplied with the equipment (antenna type 2).

The following restrictions apply to this product class:

- 9 kHz to 315 kHz frequency range;
- no field customization of the antenna(s);
- loop antenna area $< 30 \text{ m}^2$; and
- the length of any antenna loop element shall be $< \frac{\lambda}{4}$ ($< \frac{75}{f}$, where f is in MHz) or $< 30 \text{ m}$ whichever is shorter.

The transmitter carrier and spurious are limited by the maximum generated H-field, (see clauses 7.2.1 and 7.4.2 respectively).

Where a manufacturer provides a range of standard antennas, the equipment will be tested as Product Class 1 equipment, with the antenna(s) attached. The measurements shall be repeated for each of such antenna.

Product Class 2:

E-field transmitter, tested with each type of antenna to be used.

The transmitter carrier and spurious are limited by the maximum generated E-field, measured as the equivalent H-field, (see clauses 7.2.1 and 7.2.2).

7.2 Transmitter carrier output levels

7.2.1 H-field (radiated)

7.2.1.1 Definition

In the case of a transmitter with an integral or dedicated antenna, the H-field is measured in the direction of maximum field strength under specified conditions of measurement.

7.2.1.2 Methods of measurement

The measurements shall be made on an open field test site as specified in annex A. Any measured values shall be at least 6 dB above the ambient noise level.

The H-field produced by the equipment shall be measured at standard distance of 10 m. Where this is not practical, e.g. due to low power of the equipment including the antenna or with use of special field cancelling antenna, then other distances may be used. When another distance is used, the distance used and the field strength value measured shall be stated in the test report. In this case, the measured value at the actual test distance shall be extrapolated to 10 m and stated in the test report.

The H-field is measured with a shielded loop antenna connected to a measurement receiver. The measuring bandwidth and detector type of the measurement receiver shall be in accordance with clause 6.6.

The equipment under test shall operate where possible, without modulation. Where this is not possible, it shall be stated in the test report.

For transmitters using a continuous wideband swept carrier or stepped frequency function, the measurement shall be made with the sweep or stepping off. When it is not possible to turn the sweep off the measurements shall be made with the sweep on using a peak detector and this shall be stated in the test report.

For measuring equipment calibrated in dB μ V, the reading should be reduced by 51,5 dB to be converted to dB μ A/m.

7.2.1.3 Limits

The limits presented in the present document are the field strengths that allow satisfactory operation of inductive ULP-AMI systems. These levels were determined after careful analysis within CEPT.

Maximum field strength under normal and extreme conditions is given in table 5.

For the purpose of type approval, the limits from table 5 apply. Exceptionally, some administrations may have a need to provide additional protection to some existing services operating on frequencies covered by table 5.

In all cases SRDs operate on a non-interference basis. Solutions can range from site engineering to field strength modification and can be used on a case-by-case basis.

Additional information is available in CEPT/ERC Recommendation 70-03 [2] or EEC Decisions.

Table 5: H-field limits at 10 m

Frequency range (MHz)	H-field strength limit (H _f) dB μ A/m at 10 m
$0,009 \leq f \leq 0,315$	30
NOTE: Systems operating below 135 kHz may alternately choose to show conformance according to the limits and technical standards specified in annex 9 of CEPT/ERC Recommendation 70-03 [2].	

7.2.2 Radiated E-field

The provisions of this clause and subsequent clauses are applicable to devices designed to intentionally radiate an electric field.

7.2.2.1 Definition

The radiated E-field is defined as the E-field in the direction of maximum field strength under the specified conditions of measurement. This is defined for a transmitter with an integral or dedicated antenna.

7.2.2.2 Methods of measurement

The transmitter radiated E-field is based on the equivalent H-field, measured at 10 m.

The H-field is measured with a shielded loop antenna connected to a measurement receiver. The measuring bandwidth and detector type of the measurement receiver shall be in accordance with clause 6.6.

For a detailed explanation of the relationship between E-field and H-field, see annex B.

7.2.2.3 Limits

In the frequency range 9 kHz to 315 kHz, the limits of H_{ef} follow the H-fields limits, H_f , as given in clause 7.2.1.3, table 5 with an additional correction factor C. The factor given below is specific for a 10 m measuring distance.

The limit $H_{ef} = H_f + C$

where:

$$C = 20 \times \log (f_c/4,78 \times 10^6) \text{ dB};$$

and where:

f_c is the carrier frequency in Hz.

7.3 Permitted frequency range of the modulation bandwidth

The permitted frequency range shall be stated by the applicant.

7.3.1 Definition

The modulation bandwidth contains all associated side bands above the following level:

- a) for carrier frequencies in the range of 9 kHz to 315 kHz, at the highest level of either:
 - 20 dB below the carrier or the appropriate spurious limit, see clause 7.4.

Where the assigned frequency band has been divided into sub-bands by the regulatory body, the above measuring levels and bandwidths apply inside these sub-bands.

Devices whose carrier level is below the spurious limit, see clause 7.4, do not have a defined modulation bandwidth.

7.3.2 Method of measurement

The transmitter shall be connected to all manufacturer supplied antenna(s). The spectrum analyser shall be connected to a shielded loop antenna placed at any convenient distance from the transmitter antenna.

The transmitter shall be operated at the nominal carrier power or field strength measured under normal test conditions in clause 7.2. The attenuator shall be adjusted to an appropriate level displayed at the spectrum analyser screen.

The transmitter shall be modulated with standard test modulation (see clauses 6.1 and 6.1.1). If the equipment cannot be modulated externally, the internal modulating signal shall be used.

For transmitters using a continuous wideband swept carrier the measurement shall be made with the sweep on.

The output of the transmitter, with or without test fixture, shall be measured by using a spectrum analyser with a resolution bandwidth appropriate to accept all major side bands. Normally this would be a resolution bandwidth setting of approximately 1 % of the 20 dB bandwidth. The power level calibration of the spectrum analyser shall then be related to the power level or field strength measured in clause 7.2. The calculation will be used to calculate the absolute level of the sideband power.

The test laboratory shall ensure that the spectrum analyser's span is sufficiently wide enough to ensure that the carrier and all its major side bands are captured.

The difference between the frequencies of the upper and lower points, where the displayed power envelope of the modulation including frequency drift is equal to the appropriate level defined in clause 7.3.1 is recorded as the modulation bandwidth.

The measurements shall be made during normal and extreme test conditions (clauses 5.4.1 and 5.4.2 applied simultaneously).

7.3.3 Limits

The permitted range of the modulation bandwidth shall be within the limits of the assigned frequency band stated in CEPT/ERC Recommendation 70-03 [2] or ERC Decisions.

7.4 Spurious emissions

7.4.1 Definition

Spurious emissions are emissions at frequencies other than those of the carrier and sidebands associated with normal test modulation (clause 6.1). The level of spurious emissions shall be measured only for frequencies below 30 MHz at normal conditions (clause 5.3) as:

- 1) their effective radiated power or field strength when radiated by the cabinet with integral antenna, if applicable, and any other dedicated antenna supplied by the manufacturer.

7.4.2 Radiated field strength

This clause refers to clause 7.4.1; indent 1.

7.4.2.1 Methods of measurement (< 30 MHz)

This applies to all Product Classes.

The field strength shall be measured for frequencies below 30 MHz. The equipment under test shall be measured at a distance of 10 m on an outdoor test site. The test antenna shall be a calibrated shielded magnetic field antenna. The equipment under test and test antenna shall be arranged as stated in clause A.1.1.

The equipment under test shall be switched on with normal modulation. The characteristics of the modulation signal used shall be stated in the test report. The measuring receiver shall be tuned over the frequency range 9 kHz to 30 MHz, except for the frequency band in which the transmitter is intended to operate.

At each frequency at which a relevant spurious signal is detected the equipment under test and the test antenna shall be rotated until maximum field strength is indicated on the measuring receiver. This level shall be noted.

If the transmitter can be operated in the standby mode, then the measurements shall be repeated in the standby mode.

For measuring equipment calibrated in dB μ V, the reading should be reduced by 51,5 dB to be converted to dB μ A/m.

7.4.2.2 Limits

Radiated spurious emissions below 30 MHz shall not exceed the generated H-field dB μ A/m at 10 m given in table 6.

Table 6

State	Frequency $9 \text{ kHz} \leq f < 10 \text{ MHz}$	Frequency $10 \text{ MHz} \leq f < 30 \text{ MHz}$
Transmit	10 dB μ A/m	-10 dB μ A/m
Standby	-5 dB μ A/m	-25 dB μ A/m

7.5 Duty cycle

7.5.1 Definitions

For the purpose of the present document the term duty cycle refers to the ratio of the total on time of the "message" to the total off time in any one hour period under repeated operation during the time measurement interval. The device may be triggered either automatically or manually and depending on how the device is triggered will also depend on whether the duty cycle is fixed or random.

7.5.2 Declaration

For software controlled or pre-programmed devices, the applicant shall declare the duty cycle class for the equipment under test, see table 7.

For manually activated or event dependant devices, with or without software controlled functions, the applicant shall declare whether the device once triggered, follows a pre-programmed cycle, or whether the transmission is constant until the activation mechanism is released or otherwise reset. The applicant shall also give a description of the application for the device and include a typical usage pattern for maximizing duty cycle that would occur in a period of 1 hour. The typical usage pattern as declared by the applicant shall be used to determine the duty cycle and hence the duty class, see table 7. Maximum duty cycle permitted is 10 %.

Where an acknowledgement is required, the additional transmitter on-time shall be included and declared by the manufacturer.

7.5.3 Duty cycle classes

In a period of 1 hour the duty cycle shall not exceed the values given in table 7.

Table 7

Duty cycle Class	Duty cycle ratio
1	< 0,1 %
2	< 1,0 %
3	< 10 %

8 Receiver requirement

8.1 Blocking or desensitization

8.1.1 Definition

Blocking is a measure of the capability of the receiver to receive a wanted modulated signal without exceeding a given degradation due to the presence of an unwanted input signal at any frequencies other than those of the spurious responses adjacent selectivity. Receivers implanted in a human body that use error detection coding and recognize a limited command set such as pacemakers, defibrillators, etc., are not required to perform this test.

8.1.2 Methods of measurement

This measurement shall be conducted under normal conditions.

Two signal generators A and B shall be connected to the receiver via a combining network to the receiver either:

- a) via a test fixture or a test antenna that couples to the receiver integral or dedicated antenna; or
- b) via a test fixture directly to the receiver permanent or temporary antenna connector.

The method of coupling to the receiver shall be stated in the test report.

Signal generator A shall be at the nominal frequency of the receiver, with normal modulation of the wanted signal. Signal generator B shall be unmodulated and shall be adjusted to a test frequency above that of the upper band edge as defined below.

Initially signal generator B shall be switched off and by using signal generator A the minimum level giving sufficient response shall be established. The output level of generator A shall then be increased by 3 dB.

Signal generator B is then switched on and adjusted until the wanted criteria is met. For purposes of this test, the criteria are considered to be met as long as the receiver always protects the health and safety of the patient. For example, techniques that accomplish this may detect corrupted data and mark it as invalid data or the data link may cease functioning during this phase of the testing. The nature of the technique used to protect the patient and the level at which it functions to provide this protection shall be stated in the test report.

The frequency for generator B is defined by the following procedure:

- receiving upper band edge: highest operating receiver frequency + receiver bandwidth;
- receiving lower band edge: lowest operating receiver frequency - receiver bandwidth.

The receiver centre frequency and bandwidth may be measured or may be declared by the manufacturer.

For systems with swept operating frequencies:

- receiving upper band edge: high end of sweep range + receiver bandwidth;
- receiving lower band edge: low end of sweep range - receiver bandwidth.

The receiver bandwidth and sweeping range may be measured or may be declared by the manufacturer.

For blocking measurements above the receive frequency:

- The frequency for generator B is calculated as the upper band edge plus an offset multiplier of the receiver bandwidth.

For blocking measurements below the receive frequency:

- The frequency for generator B is calculated as the lower band edge minus an offset multiplier of the receiver bandwidth.

The blocking or desensitization shall be recorded as the ratio in dB of lowest level of the unwanted signal (generator B) to the level of the wanted signal (generator A).

8.1.3 Limits

The blocking ratio, for any frequency within the specified ranges, shall not be less than the values given in table 8, except at frequencies on which spurious responses are found. The limit value is determined by a reference limit (Ref) plus a correction factor (dB) depending of the appropriate receiver classification.

Table 8: Receiver blocking or desensitization limits

Receiver Classification	Generator B frequency offset from band edge	Limit
1	2 x receiver bandwidth or 50 kHz whichever is greater	Ref
2	2 x receiver bandwidth or 50 kHz whichever is greater	Ref -15 dB
	4 x receiver bandwidth or 50 kHz whichever is greater	Ref -10 dB
	8 x receiver bandwidth or 50 kHz whichever is greater	Ref -5 dB
	20 x receiver bandwidth or 50 kHz whichever is greater	Ref
Reference limit (Ref) = 30 dB at 9 kHz increasing with 10 dB/decade to 65 dB at 30 MHz.		

8.2 Receiver spurious radiation

These requirements do not apply to receivers used in combination with permanently co-located transmitters continuously transmitting. Co-located is defined as < 3 m. In these cases the receivers will be tested together with the transmitter in operating mode (see clause 7.4). Measurements above 30 MHz are not required.

8.2.1 Definition

Spurious radiation from receivers consists of emissions radiated from the antenna, the chassis and case of the receiver. It is specified as the radiated power of a discrete signal. Included in this definition are modulation products that are outside the 20 dB down point on either side of the fundamental emission.

8.2.1.1 Methods of measurement

The method of measurement defined in clause 7.4.2.1 shall be used.

Convert reading by 51,5 dB for measuring equipment calibrated in dB μ V or dB μ V/m.

8.2.1.2 Limits

The spurious components below 30 MHz shall not exceed the generated H-field dB μ A/m values at 10 m according to table 9.

Table 9: Receiver spurious radiation limits

Frequency 9 kHz \leq f < 10 MHz	Frequency 10 MHz \leq f \leq 30 MHz
-5 dB μ A/m	-25 dB μ A/m

9 Measurement uncertainty

The interpretation of the results recorded in the test report for the measurements described in the present document shall be as follows:

- the measured value related to the corresponding limit shall be used to decide whether an equipment meets the requirements of the present document;
- the value of the measurement uncertainty for the measurement of each parameter shall be separately included in the test report;
- the value of the measurement uncertainty shall be, for each measurement, equal to or lower than the figures given below:

RF frequency	$\pm 1 \times 10^{-7}$
RF power, conducted	± 1 dB
RF power, radiated	± 6 dB
Temperature	± 1 °C
Humidity	± 5 %

For the test methods, according to the present document the uncertainty figures shall be calculated according to the methods described in the ETR 028 [4] and shall correspond to an expansion factor (coverage factor) $k = 1,96$ or $k = 2$ (which provide confidence levels of respectively 95 % and 95,45 % for the case where the distributions characterizing the actual measurement uncertainties are normal (Gaussian)).

The measurement uncertainties given above are based on such expansion factors.

The particular expansion factor used for the evaluation of the measurement uncertainty shall be stated.

Annex A (normative): Radiated measurements

A.1 Test sites and general arrangements for measurements involving the use of radiated fields

A.1.1 Outdoor test site

The outdoor test site shall be on a reasonably level surface or ground. For measurements at frequencies below 30 MHz no artificial ground plane shall be used and the measurement antenna shall be of a shielded loop type and placed on a table of 1-m height placed 10 m from the EUT. Closer distances are permitted if measurements of low level emissions are performed. For measurements at frequencies 30 MHz and above, a conducting ground plane of at least 5 m diameter shall be provided at one point on the site. In the middle of this ground plane, a non-conducting support, capable of rotation through 360° in the horizontal plane, shall be used to support the test sample in its standard position, at 1 m above the ground plane, with the exception of equipment with floor standing antenna. For this equipment, the antenna shall be raised, on a non-conducting support, 100 mm above the turntable, the point(s) of contact being consistent with normal use. The test site shall be large enough to allow the erection of a measuring or transmitting antenna at a distance of 10 m or optionally 30 m. The distance actually used shall be recorded with the results of the tests carried out on the site.

Sufficient precautions shall be taken to ensure that reflections from extraneous objects adjacent to the site do not degrade the measurements results.

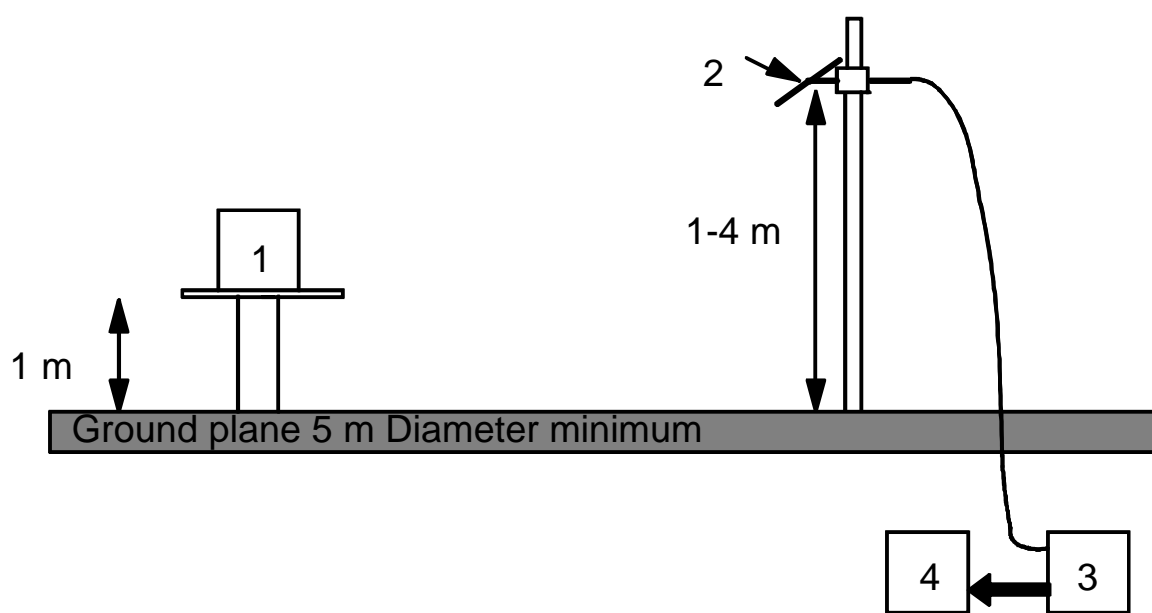

Figure A.1

A.1.1.1 Standard position

The standard position in all test sites, except for equipment which is intended to be worn on a person, shall be as follows:

- for equipment with an integral antenna, it shall be placed in the position closest to normal use as declared by the manufacturer;
- for equipment with a rigid external antenna, the antenna shall be vertical;
- for equipment with non-rigid external antenna, the antenna shall be extended vertically upwards by a non-conducting support.

For equipment intended to be worn close to the body or hand held, the non-conducting support may, at the request of the applicant be replaced with a simulated man, if appropriate. The use of the simulated man shall be stated in the test report.

The simulated man shall consist of an acrylic tube, filled with salt water (1,5 grams NaCl per litre of distilled water). The tube shall have a length of $1,7\text{ m} \pm 0,1\text{ m}$ and an internal diameter of $300\text{ mm} \pm 5\text{ mm}$ with side wall thickness of $1,5\text{ mm} \pm 0,5\text{ mm}$.

To reduce the weight of the simulated man it may be possible to use an alternative tube, which has a hollow centre of 200 mm maximum diameter.

The sample shall be fixed to the surface of the simulated man, at the appropriate height for the equipment.

A.1.1.2 Equipment in close proximity to the human body but external to it

The following provisions apply to equipment designed to be external to but in very close proximity to a human body.

For programmer/control equipment intended to be worn close to the body or hand held, the non-conducting support may, at the request of the applicant be replaced with a simulated man, if appropriate. The use of the simulated man shall be stated in the test report.

The simulated man for equipment external to the body shall consist of an acrylic tube, filled with salt water (1,5 g NaCl per litre of distilled water). The tube shall have a length of $1,7\text{ m} \pm 0,1\text{ m}$ and an internal diameter of $300\text{ mm} \pm 5\text{ mm}$ with side wall thickness of $1,5\text{ mm} \pm 0,5\text{ mm}$.

To reduce the weight of the simulated man it may be possible to use an alternative tube that has a hollow centre of 200 mm maximum diameter.

The sample shall be fixed to the surface of the simulated man, at the appropriate height for the equipment.

The following provisions apply to equipment designed to be implanted in a human body.

A.1.1.3 Active medical implant equipment

Equipment intended to be implanted in a human body for purposes of the present document should be tested in a simulated man constructed as follows in order to simulate operation of the implant under actual operating conditions as shown in figure A.2.

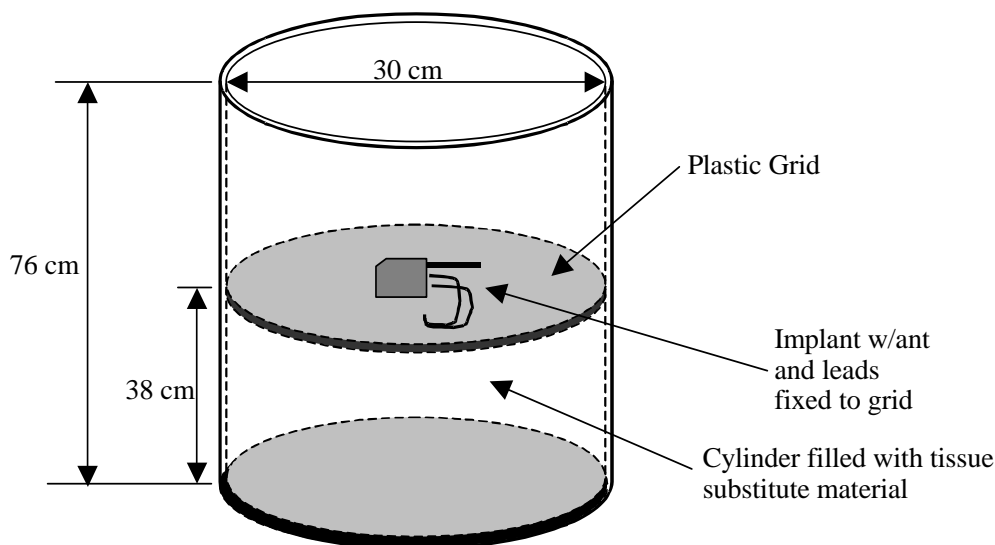

Figure A.2

A torso simulator for testing medical implant transmitters consists of a cylindrical Plexiglas container with a size of $30\text{ cm} \pm 0,5\text{ cm}$ by $76\text{ cm} \pm 0,5\text{ cm}$ with a sidewall thickness of $0,635\text{ cm} \pm 0,05\text{ cm}$. It shall be completely filled with a material that is sufficiently fluid that it will flow around the implant without any voids.

The dielectric and conductivity properties of this material should match the dielectric and conductivity properties of human muscle tissue at the centre frequency of operation or, if desired, at the measurement frequency. The saline solution specified below may be used for this purpose; however, it typically will not match these properties.

All radiated emissions measurements will be made using the above torso simulator with the tissue substitute material at a nominal temperature between 22°C and 38°C .

NOTE 1: This temperature will facilitate testing because it is representative of ambient conditions at many test sites.

A mounting fixture for the implant inside the container shall be provided that permits the radiating element or elements of the implant to be positioned vertically and horizontally. The fixture should also support any additional implant leads associated with the therapeutic function of the implant in a fixed repeatable manner such that they do not influence the measurement.

NOTE 2: In this frequency range, implant antennas are normally enclosed with the case of the implant.

For testing purposes the side of the implant case that is in closest proximity to the internal antenna shall be mounted in a vertical plane no further than $6\text{ cm} \pm 0,5\text{ cm}$ from the sidewall of the container and centred vertically within the container. When switching from vertical to horizontal positioning, the implant case shall be mounted as above except the side of the case shall be mounted in a horizontal plane. In this case it may be necessary to reposition the implant to maintain a separation as above no greater than $6\text{ cm} \pm 0,5\text{ cm}$ from the sidewall of the test fixture along its length. Implant leads shall be coiled and placed away from the implant antenna while maintaining a nominal 6 cm from the sidewall.

The above fixture shall be placed on a turntable such that the implant transmitter is located at a nominal 1,5-m above ground and at a 3-m distance from the measurement antenna.

Radiated emissions measurements shall then be performed to ensure compliance with the applicable technical specifications. In situations where the implant case that is in closest proximity to the internal antenna is unknown, the implant position will be investigated to determine the position producing maximum emissions. Data shall be recorded for this position to determine conformance with the applicable limit.

Implants that are designed to communicate with an external device may require the presence of the external device in order to transmit. Manufacturers should note that it is desirable if possible to activate normal implant transmitter function via a technique that does not require an external accessory device such as a programmer to be used.

Tissue parameters for various frequencies may be obtained from the following website: <http://niremf.ifac.cnr.it>, maintained by the ITALIAN NATIONAL RESEARCH COUNCIL, Institute for Applied Physics. Other sources can be used provided they are based on the 4-Cole-Cole equations developed by Gabriel [5]. A saline solution recognized by the medical industry as a tissue medium may be used if desired by the manufacturer. As guidance, a saline solution producing a 375 Ω -cm conductivity using a standard test cell meets this requirement.

A.1.2 Test antenna

A.1.2.1 Below 30 MHz

A calibrated loop antenna shall be used to detect the field strength from the test sample. The antenna shall be supported in the vertical plane and be rotated about a vertical axis. The lowest point of the loop shall be 1 m above ground level.

A.1.3 Optional additional indoor site

When the frequency of the signals being measured is greater than 80 MHz, use may be made of an indoor test site. If this alternative site is used, this shall be recorded in the test report.

The measurement site may be a laboratory room with a minimum area of 6 m by 7 m and at least 2,7 m in height.

Apart from the measuring apparatus and the operator, the room shall be as free as possible from reflecting objects other than the walls, floor and ceiling.

The potential reflections from the wall behind the equipment under test are reduced by placing a barrier of absorbent material in front of it. The corner reflector around the test antenna is used to reduce the effect of reflections from the opposite wall and from the floor and ceiling, in the case of horizontally polarized measurements. Similarly, the corner reflector reduces the effects of reflections from the sidewalls for vertically polarized measurements. For the lower part of the frequency range (below approximately 175 MHz), no corner reflector or absorbent barrier is needed. For practical reasons, the $\lambda/2$ antenna in figure A.2 may be replaced by an antenna of constant length, provided that this length is between $\lambda/4$ and λ at the frequency of measurement, and the sensitivity of the measuring system is sufficient. In the same way, the distance of $\lambda/2$ to the apex may be varied.

The test antenna, measuring receiver, substitution antenna and calibrated signal generator are used in a way similar to that of the general method. To ensure that errors are not caused by the propagation path approaching the point at which phase cancellation between the direct and the remaining reflected signals occurs, the substitution antenna shall be moved through a distance of $\pm 0,1$ m in the direction of the test antenna as well as in the two directions perpendicular to this first direction.

If these changes of distance cause a signal change of greater than 2 dB, the test sample should be re-sited until a change of less than 2 dB is obtained.

A.2 Guidance on the use of radiation test sites

For measurements involving the use of radiated fields, use may be made of a test site in conformity with the requirements of clause A.1. When using such a test site, the following conditions should be observed to ensure consistency of measuring results.

A.2.1 Measuring distance

Evidence indicates that the measuring distance is not critical and does not significantly affect the measuring results. For ULP-AMI inductive systems covered by the present document, the measurement distance should generally be 10 m or less. Precautions described in this annex are to be observed. Measurements at low frequencies and distances less than $\lambda/2$ are considered in the present document and shall be followed. Measuring distances of 3 m, 5 m, 10 m and 30 m are in common use in European test laboratories. Measurements at distances different to 10 m need to have a correction factor added to give a resultant at 10 m so that comparison with the limit is possible. The correction factor used shall be stated and justified in the test report.

A.2.2 Auxiliary cables

The position of auxiliary cables (power supply and microphone cables etc.) which are not adequately de-coupled, may cause variations in the measurement results. In order to get reproducible results, cables and wires of auxiliaries should be arranged vertically downwards (through a hole in the non conducting support), or as specified in the technical documentation supplied with the equipment.

Care shall be taken to ensure that test cables do not adversely affect the measuring result.

Annex B (normative):
H-field limit correction factor for generated E-fields

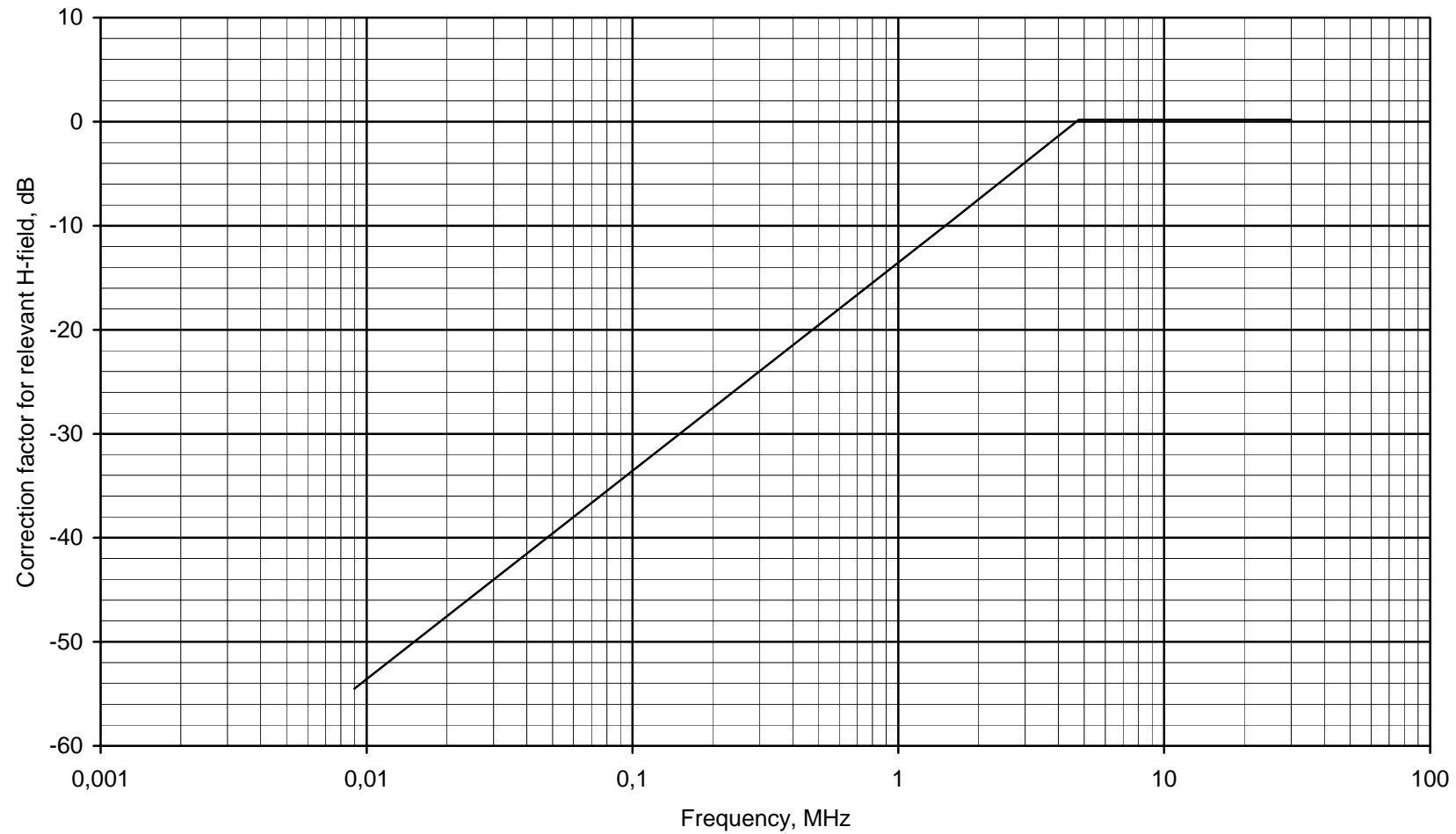

Figure B.1

Annex C (informative): E-fields in the near field at low frequencies

E-field at low frequencies is often in the near field and it is in reality only possible to measure the H-field component with the shielded loop antenna; in this case there is also a relation between the E-field and the H-field by the wave impedance Z . In the near field the wave impedance is highly dependent on the type of radiating antenna (loop or open end wire) and the wavelength. If the power density at a certain distance is the same for a H-field and an E-field generated signal, the following calculation can be made:

In the direction of maximum power in the near field, the power density S is:

$$S = \frac{E^2}{Z_e} = H_e^2 Z_e = H_m^2 Z_m \quad (1)$$

where:

S = power density;

E = electrical field generated by an E-field antenna at distance d ;

H_e = magnetic field generated by an E-field antenna at distance d ;

H_m = magnetic field generated by a H-field antenna at distance d ;

Z_e = wave impedance of a field generated by an E-field antenna at distance d ;

Z_m = wave impedance of a field generated by an H-field antenna at distance d .

$$Z_m = Z_0 2\pi \frac{d}{\lambda} \quad \text{if } d < \frac{\lambda}{2\pi} \quad (\text{near field}) \quad (2)$$

$$Z_e = Z_0 \frac{\lambda}{2\pi d} \quad \text{if } d < \frac{\lambda}{2\pi} \quad (\text{near field}) \quad (3)$$

Equation (1) gives:

$$H_e = H_m \sqrt{\frac{Z_m}{Z_e}} \quad (A/m) \quad (4)$$

Equation (2) and (3) into (4) gives:

$$H_e = H_m \frac{2\pi d}{\lambda} = H_m \frac{2\pi d f_c}{300} \quad (5)$$

where f_c is the carrier frequency in MHz.

For $2\pi d/\lambda = 1$, $d = 10$ and $f_c = 4,78$ MHz, and using equation (5), this gives:

$$H_e = H_m \frac{f_c}{4,78} \quad (f \text{ in MHz}) \quad (6)$$

For $2\pi d/\lambda < 1$ if $f_c < 4,78$ MHz then equation (5) is valid, (i.e. near field).

For $2\pi d/\lambda \geq 1$ if $f_c > 4,78$ MHz then $H_e = H_m$, (i.e. far field).

The method allows an electric generated E-field to be measured as a magnetic generated H-field by adding a correction factor derived from (6).

Annex D (normative): H-field measurements at other distances than 10 m

Measurements at longer distances than 10 m may be relevant for equipment using combination loop antennas having an increased reduction of the radiated H-field versus distance. An example of this performance is a "figure eight antenna" having two identical but physical spaced antenna loops driven with opposite phased currents.

The present document allows field measurements to be made at other distances than 10 m. In this case, the appropriate H-field limit, H_x , for applicant requested measurement distance, d_x , shall be calculated. The calculation of the new limit, H_x , shall be made by the applicant. Both the calculation of new limit and the requested measurement distance shall be stated in the Application and Test Report.

The following procedure shall be used:

- a) For $\frac{\lambda}{2\pi} \geq 3d(m)$;

where d is either 10 m or the new measurements distance, d_x , whichever is the longest).

The new limit H_x in dB μ A/m at distance d_x is determined from the 10 m limit H_{10} in dB μ A/m by:

$$H_x = H_{10} + 60 \times \log \frac{10}{d_x} (\text{dB}\mu\text{A} / \text{m}) \quad (1)$$

- b) For $\frac{\lambda}{2\pi} \leq 0,3d(m)$;

where d is either 10 m or the new measurements distance d_x whichever is the shortest.

The new limit H_x in dB μ A/m at distance d_x is determined from the 10 m limit H_{10} in dB μ A/m by:

$$H_x = H_{10} + 20 \times \log \frac{10}{d_x} (\text{dB}\mu\text{A} / \text{m}) \quad (2)$$

- c) If $\frac{\lambda}{2\pi}$ is between the two boundaries determined in A and B above the following steps shall be followed:

Step 1: Calculate the radian wavelength, x :

$$x = \frac{\lambda}{2\pi} = \frac{300}{2\pi f} (m); \text{ where } f \text{ is in MHz} \quad (3)$$

Step 2: Calculate the magnetic dipole moment from the 10 m limit, H_{10} in A/m by either:

- a) for $x \times 2,354 \geq 10 m$

$$m = H_{10} \frac{2\pi x \times 10^3}{\sqrt{x^2 + 10^2}} (\text{Am}^2) \text{ or;} \quad (4)$$

- b) for $x \times 2,354 < 10 m$

$$m = H_{10} \frac{x^2 \times 10^3 \times 4\pi}{\sqrt{x^4 + x^2 \times 10^2 + 10^4}} (\text{Am}^2) \quad (5)$$

Step 3: Calculate the new limit H_x in A/m for the new measurements distance, d_x is calculated by either:

- a) for $d_x \leq x \times 2,354$

$$H_x = \frac{m\sqrt{x^2 + d_x^2}}{2\pi(x + d_x^3)} (A/m) \text{ or;} \quad (6)$$

- b) for $d_x > x \times 2,354$

$$H_x = \frac{m\sqrt{x^4 + x^2 d_x^2 + d_x^4}}{4\pi(x^2 + d_x^3)} (A/m) \quad (7)$$

The calculated value for H_x in A/m may be converted to dB μ A/m as appropriate.

As an example, the H-field limits at 10 m are converted to 30 m by using the above method.

Table D.1: H-field limits at 30 m

Frequency range (MHz)	H-field strength limit (H_f) dB μ A/m at 30 m
$0,009 \leq f < 0,03$	43,5 or according to note
$0,03 \leq f < 0,07$ $0,119 \leq f < 0,135$	43,5 at 0,03 MHz descending 3 dB/octave or according to note
$0,05975 \leq f < 0,06025$ $0,07 \leq f < 0,119$	13,5
$0,135 \leq f < 1,26$	8,7 at 0,135 MHz descending 3 dB/octave
$1,26 \leq f < 30$	-1
$6,765 \leq f \leq 6,795$ $13,553 \leq f \leq 13,567$ $26,957 \leq f \leq 27,283$	32,5

NOTE: For the frequency ranges 9 kHz to 70 kHz and 119 kHz to 135 kHz, the following additional restrictions apply to the higher limits:

- for loop coil antennas with an area $\geq 0,16 \text{ m}^2$;
- for loop coil antennas with an area between $0,05 \text{ m}^2$ and $0,16 \text{ m}^2$, with a correction factor. The limit is: $+10 \times \log(\text{area}/0,16 \text{ m}^2)$.

Annex E (informative): Bibliography

- ERC Report 44 (1997): "Sharing between inductive systems and radiocommunications systems in the band 9 kHz to 135 kHz".
- ECC Report 12 (2002): 'ULTRA LOW POWER ACTIVE MEDICAL IMPLANT SYSTEMS (ULP-AMI)'.
- CISPR 16-1: "Specifications for radio disturbance and immunity measuring apparatus and methods; Part 1: Radio disturbance and immunity measuring apparatus".
- ETSI EN 301 489-3 (V1.2.1): "Electromagnetic compatibility and Radio spectrum Matters (ERM); ElectroMagnetic Compatibility (EMC) standard for radio equipment and services; Part 3: Specific conditions for Short-Range Devices (SRD) operating on frequencies between 9 kHz and 40 GHz".
- Directive 98/34/EC of the European Parliament and of the Council of 22 June 1998 laying down a procedure for the provision of information in the field of technical standards and regulations.
- ETSI EN 300 330-1 (V1.3.1): "Electromagnetic compatibility and Radio Spectrum Matters (ERM); Short Range Devices; Radio equipment in the frequency range 9 kHz to 25 MHz and inductive loop systems in the frequency range 9 kHz to 30 MHz Part 1: Technical characteristics and test methods".
- IEC 60601-1-2 (2001): "Medical electrical equipment; Part 1-2: General requirements for safety; Collateral standard: Electromagnetic compatibility - Requirements and tests".
- Council Directive 90/385/EEC of 20 June 1990 on the approximation of the laws of the Member States relating to active implantable medical devices (AMD Directive).
- RADIOFREQUENCY RADIATION DOSIMETRY HANDBOOK (October 1986), USAF School of Aerospace Medicine, Aerospace Medical Division (AFSC), Brooks Air Force Base, TX 78235-5301.

History

Document history				
V1.1.1	May 2003	Public Enquiry	PE 20030919:	2003-05-21 to 2003-09-19
V1.1.1	January 2004	Vote	V 20040312:	2003-01-12 to 2004-03-12