

ETSI EN 302 186 V1.1.1 (2004-01)

Candidate Harmonized European Standard (Telecommunications series)

**Satellite Earth Stations and Systems (SES);
Harmonized EN for satellite mobile
Aircraft Earth Stations (AESs)
operating in the 11/12/14 GHz frequency bands
covering essential requirements
under article 3.2 of the R&TTE Directive**



Reference

DEN/SES-00085

Keywords

aeronautical, air interface, AMSS, earth station,
FSS, GSO, mobile, MSS, regulation, satellite

ETSI

650 Route des Lucioles
F-06921 Sophia Antipolis Cedex - FRANCE

Tel.: +33 4 92 94 42 00 Fax: +33 4 93 65 47 16

Siret N° 348 623 562 00017 - NAF 742 C
Association à but non lucratif enregistrée à la
Sous-Préfecture de Grasse (06) N° 7803/88

Important notice

Individual copies of the present document can be downloaded from:

<http://www.etsi.org>

The present document may be made available in more than one electronic version or in print. In any case of existing or perceived difference in contents between such versions, the reference version is the Portable Document Format (PDF). In case of dispute, the reference shall be the printing on ETSI printers of the PDF version kept on a specific network drive within ETSI Secretariat.

Users of the present document should be aware that the document may be subject to revision or change of status. Information on the current status of this and other ETSI documents is available at

<http://portal.etsi.org/tb/status/status.asp>

If you find errors in the present document, send your comment to:

editor@etsi.org

Copyright Notification

No part may be reproduced except as authorized by written permission.
The copyright and the foregoing restriction extend to reproduction in all media.

© European Telecommunications Standards Institute 2004.
All rights reserved.

DECT™, **PLUGTESTS™** and **UMTS™** are Trade Marks of ETSI registered for the benefit of its Members.
TIPHON™ and the **TIPHON logo** are Trade Marks currently being registered by ETSI for the benefit of its Members.
3GPP™ is a Trade Mark of ETSI registered for the benefit of its Members and of the 3GPP Organizational Partners.

Contents

Intellectual Property Rights	6
Foreword.....	6
Introduction	7
1 Scope	9
2 References	10
3 Definitions, symbols and abbreviations	11
3.1 Definitions	11
3.2 Symbols.....	14
3.3 Abbreviations	14
4 Technical requirement specifications	15
4.1 General	15
4.1.1 Environmental profile	15
4.2 Conformance requirements	15
4.2.1 General.....	15
4.2.2 Spurious radiation	16
4.2.2.1 Justification	16
4.2.2.2 Specification.....	16
4.2.2.3 Conformance tests	17
4.2.3 On-axis spurious radiation	17
4.2.3.1 Justification	17
4.2.3.2 Specification.....	17
4.2.3.2.1 "Carrier-on" state.....	17
4.2.3.2.2 "Carrier-off" state and "transmission disabled" state.....	18
4.2.3.3 Conformance tests	18
4.2.4 Off-axis EIRP emissions density in the nominated bandwidth.....	18
4.2.4.1 Justification	18
4.2.4.2 Specification.....	18
4.2.4.3 Conformance tests	19
4.2.5 Control and Monitoring Functions (CMF).....	19
4.2.5.1 Processor monitoring	20
4.2.5.1.1 Justification	20
4.2.5.1.2 Specification	20
4.2.5.1.3 Conformance tests	20
4.2.5.2 Transmit subsystem monitoring	21
4.2.5.2.1 Justification	21
4.2.5.2.2 Specification	21
4.2.5.2.3 Conformance tests	21
4.2.5.3 Power-on/Reset	21
4.2.5.3.1 Justification	21
4.2.5.3.2 Specification	21
4.2.5.3.3 Conformance tests	21
4.2.5.4 Control Channel (CC) reception	21
4.2.5.4.1 Justification	21
4.2.5.4.2 Specification	21
4.2.5.4.3 Conformance tests	21
4.2.5.5 Network control commands	22
4.2.5.5.1 Justification	22
4.2.5.5.2 Specification	22
4.2.5.5.3 Conformance tests	22
4.2.5.6 Initial burst transmission	22
4.2.5.6.1 General	22
4.2.5.6.2 Specification	22
4.2.5.6.3 Conformance tests	23

4.2.6	Power Flux Density at the surface of the earth	23
4.2.6.1	General	23
4.2.6.2	Power flux density limits in the 14,00 GHz to 14,50 GHz frequency band	23
4.2.6.2.1	Justification	23
4.2.6.2.2	Specification 1: mode of PFD limitation	23
4.2.6.2.3	Specification 2: Location where to limit the PFD	24
4.2.6.2.4	Specification 3: PFD limitation	24
4.2.6.2.5	Specification 4: Fault conditions	25
4.2.6.2.6	Conformance tests	25
5	Testing for compliance with technical requirements.....	25
5.1	Environmental conditions for testing	25
5.2	Essential radio test suites.....	25
6	Test methods	26
6.0	General	26
6.1	Spurious radiation.....	27
6.1.1	Test method	27
6.1.1.1	Up to 1 000 MHz (see clause 4.2.2.2, table 2)	27
6.1.1.1.1	Test site.....	27
6.1.1.1.2	Measuring receivers.....	28
6.1.1.1.3	Procedure.....	28
6.1.1.2	Above 1 000 MHz (see clause 4.2.2.2, tables 3 and 4)	28
6.1.1.2.1	Identification of the significant frequencies of spurious radiation	28
6.1.1.2.2	Measurement of radiated power levels of identified spurious radiation	29
6.2	On-axis spurious radiation.....	30
6.2.1	Test method	30
6.2.1.1	Test site	30
6.2.1.2	Method of measurement.....	30
6.2.1.2.1	General	30
6.2.1.2.2	Method of measurement at the antenna flange	30
6.2.1.2.3	Method of measurement with a test antenna	31
6.3	Off-axis EIRP emissions density in the nominated bandwidth	32
6.3.1	General.....	32
6.3.2	rms antenna pointing accuracy.....	33
6.3.2.1	Method of measurement.....	33
6.3.3	Measurement of the off-axis EIRP without the antenna	33
6.3.3.1	Transmitter output power density	33
6.3.3.1.1	Method of measurement	34
6.3.3.2	Antenna transmit gain	34
6.3.3.2.1	General	34
6.3.3.2.2	Test site.....	34
6.3.3.2.3	Method of measurement	35
6.3.3.3	Antenna transmit radiation patterns	36
6.3.3.3.1	General	36
6.3.3.3.2	Test site.....	36
6.3.3.3.3	Method of measurement	36
6.3.3.4	Computation of results	37
6.3.4	Measurement of the off-axis EIRP with the antenna	37
6.3.4.1	General	37
6.3.4.2	Maximum EIRP density per 40 kHz ratio relative to the EIRP.....	37
6.3.4.2.1	Method of measurement	38
6.3.4.3	Maximum on-axis EIRP.....	38
6.3.4.3.1	General	38
6.3.4.3.2	Test site.....	38
6.3.4.3.3	Method of measurement	39
6.3.4.4	Antenna transmit radiation patterns	40
6.3.4.4.1	General	40
6.3.4.4.2	Test site.....	40
6.3.4.4.3	Method of measurement	41
6.3.4.5	Computation of results	42
6.4	Power Flux Density Test	42

6.4.1	General.....	42
6.4.2	Verification of specification 1: mode of PFD limitation.....	42
6.4.3	Verification of specification 2: Location where to limit the PFD.....	43
6.4.4	Verification of specification 3: PFD limitation.....	43
6.4.4.1	Measurement of the antenna radiation pattern below the aircraft fuselage.....	43
6.4.4.1.1	General.....	43
6.4.4.1.2	Test site.....	43
6.4.4.1.3	Test method procedure.....	43
6.4.4.2	Measurement of on-axis EIRP as a function of altitude.....	44
6.4.4.2.1	General.....	44
6.4.4.2.2	Test site.....	44
6.4.4.2.3	Method of measurement with a test antenna.....	45
6.4.4.3	Computation of the power flux density at the surface of the Earth.....	45
6.4.5	Verification of specification 4: Fault conditions.....	46
6.4.5.1	Test Arrangement.....	46
6.4.5.2	Test method.....	46
6.5	Control and monitoring.....	47
6.5.1	Test arrangement.....	47
6.5.2	Processor monitoring.....	48
6.5.2.1	Test method.....	48
6.5.3	Transmit subsystem monitoring.....	48
6.5.3.1	Test method.....	48
6.5.4	Power-on/Reset.....	49
6.5.4.1	Test method.....	49
6.5.5	Control Channel (CC) reception.....	49
6.5.5.1	Test method.....	49
6.5.6	Network control commands.....	50
6.5.6.1	Test method.....	50
6.5.7	Initial burst transmission.....	51
6.5.7.1	Test method.....	51
Annex A (normative): The EN Requirements Table (EN-RT).....		52
Annex B (normative): Environmental conditions.....		53
B.1	General.....	53
B.2	Environmental conformance requirements.....	53
B.3	Environmental test conditions.....	53
Annex C (informative): Bibliography.....		55
History.....		56

Intellectual Property Rights

IPRs essential or potentially essential to the present document may have been declared to ETSI. The information pertaining to these essential IPRs, if any, is publicly available for **ETSI members and non-members**, and can be found in ETSI SR 000 314: "*Intellectual Property Rights (IPRs); Essential, or potentially Essential, IPRs notified to ETSI in respect of ETSI standards*", which is available from the ETSI Secretariat. Latest updates are available on the ETSI Web server (<http://webapp.etsi.org/IPR/home.asp>).

Pursuant to the ETSI IPR Policy, no investigation, including IPR searches, has been carried out by ETSI. No guarantee can be given as to the existence of other IPRs not referenced in ETSI SR 000 314 (or the updates on the ETSI Web server) which are, or may be, or may become, essential to the present document.

Foreword

This Candidate Harmonized European Standard (Telecommunications series) has been produced by ETSI Technical Committee Satellite Earth Stations and Systems (SES).

The present document has been produced by ETSI in response to a mandate from the European Commission issued under Council Directive 98/34/EC (as amended) laying down a procedure for the provision of information in the field of technical standards and regulations.

The present document is intended to become a Harmonized Standard, the reference of which will be published in the Official Journal of the European Communities referencing the Directive 1999/5/EC [1] of the European Parliament and of the Council of 9 March 1999 on radio equipment and telecommunications terminal equipment and the mutual recognition of their conformity ("the R&TTE Directive").

Technical specifications relevant to Directive 1999/5/EC [1] are given in annex A.

National transposition dates	
Date of adoption of this EN:	23 January 2004
Date of latest announcement of this EN (doa):	30 April 2004
Date of latest publication of new National Standard or endorsement of this EN (dop/e):	31 October 2004
Date of withdrawal of any conflicting National Standard (dow):	31 October 2004

Introduction

The present document is part of a set of standards designed to fit in a modular structure to cover all radio and telecommunications terminal equipment under the R&TTE Directive [1]. Each standard is a module in the structure. The modular structure is shown in figure 1a.

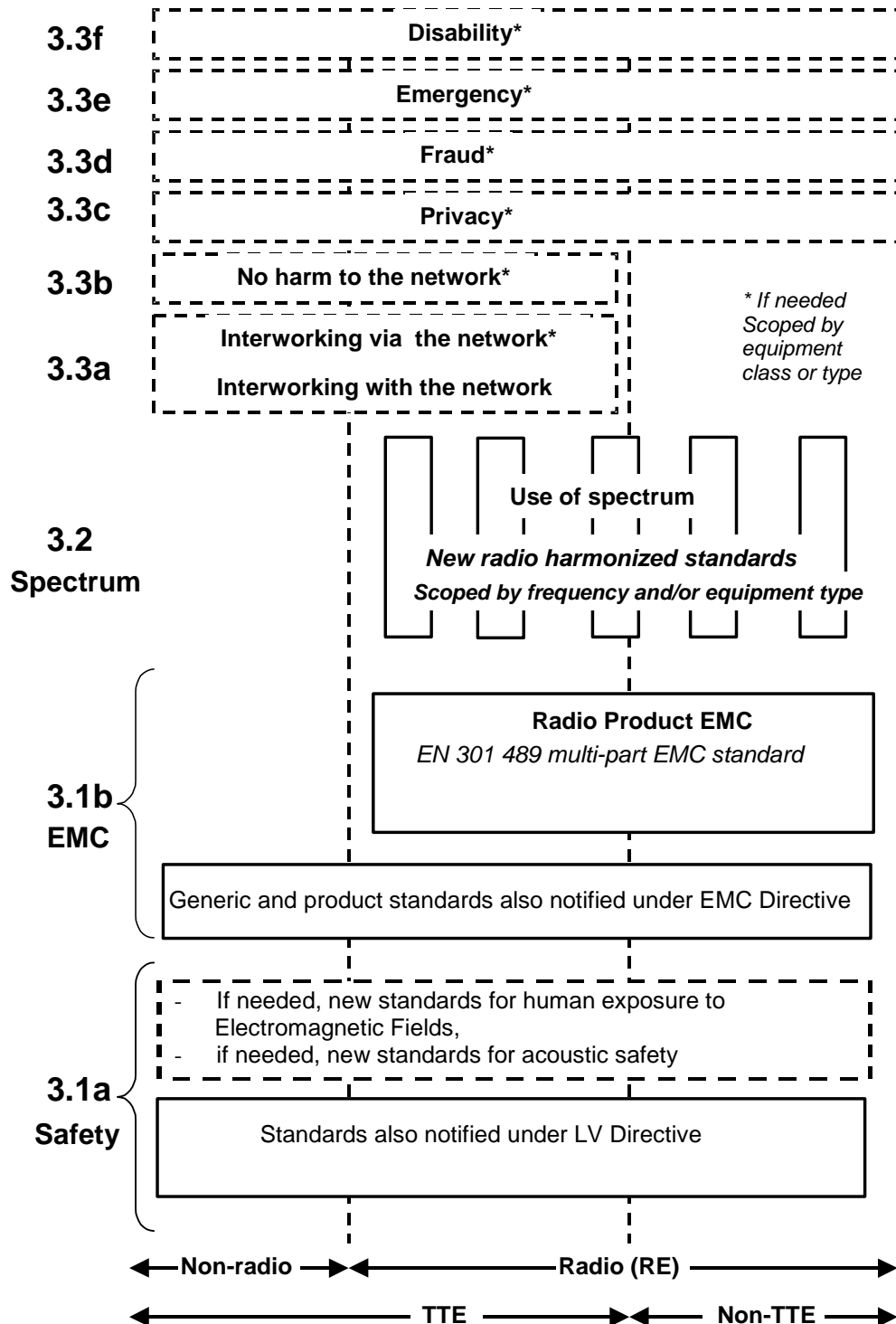

Figure 1a: Modular structure for the various standards used under the R&TTE Directive [1]

The left hand edge of the figure 1a shows the different clauses of article 3 of the R&TTE Directive [1].

For article 3.3 various horizontal boxes are shown. Dotted lines indicate that at the time of publication of the present document essential requirements in these areas have to be adopted by the Commission. If such essential requirements are adopted, and as far and as long as they are applicable, they will justify individual standards whose scope is likely to be specified by function or interface type.

The vertical boxes show the standards under article 3.2 for the use of the radio spectrum by radio equipment. The scopes of these standards are specified either by frequency (normally in the case where frequency bands are harmonized) or by radio equipment type.

For article 3.1b the diagram shows EN 301 489, the multi-part product EMC standard for radio used under the EMC Directive (see bibliography).

For article 3.1a the diagram shows the existing safety standards currently used under the LV Directive (see bibliography) and new standards covering human exposure to electromagnetic fields. New standards covering acoustic safety may also be required.

The bottom of the figure shows the relationship of the standards to radio equipment and telecommunications terminal equipment. A particular equipment may be radio equipment, telecommunications terminal equipment or both. A radio spectrum standard will apply if it is radio equipment. An article 3.3 standard will apply as well only if the relevant essential requirement under the R&TTE Directive [1] is adopted by the Commission and if the equipment in question is covered by the scope of the corresponding standard. Thus, depending on the nature of the equipment, the essential requirements under the R&TTE Directive [1] may be covered in a set of standards.

The modularity principle has been taken because:

- it minimizes the number of standards needed. Because equipment may, in fact, have multiple interfaces and functions it is not practicable to produce a single standard for each possible combination of functions that may occur in an equipment;
- it provides scope for standards to be added:
 - under article 3.2 when new frequency bands are agreed; or
 - under article 3.3 should the Commission take the necessary decisions without requiring alteration of standards that are already published;
- it clarifies, simplifies and promotes the usage of Harmonized Standards as the relevant means of conformity assessment.

The requirements have been selected to ensure an adequate level of compatibility with other radio services.

The present document may not cover those cases where a potential source of interference which is producing individually repeated transient phenomena or a continuous phenomenon is present, e.g. a radar or broadcast site in the near vicinity. In such a case it may be necessary to use special protection applied to either the source of interference, or the interfered part or both.

The present document does not contain any requirement, recommendation or information about the installation of the AES on aircraft.

The determination of the parameters of the AES using a given GeoStationary Orbiting (GSO) satellite for the protection of the spectrum allocated to that satellite, is considered to be under the responsibility of the satellite operator or the satellite network operators.

1 Scope

The present document specifies certain minimum technical performance requirements of Aircraft Earth Station (AES) equipment with both transmit and receive capabilities for provision of aeronautical mobile satellite service, in the frequency bands given in table 1.

Table 1: Frequency bands for the AES equipment specified in the present document

Mode of Operation	Frequency Band
AES transmit	14,00 GHz to 14,50 GHz
AES receive	10,70 GHz to 11,70 GHz
AES receive	12,50 GHz to 12,75 GHz
NOTE: The AESs are operating in one or more frequency ranges of the Fixed and Mobile-Satellite Services.	

The AES has the following characteristics:

- These AESs are equipment for installation on aircraft.
- The AES could consist of a number of modules from the antenna subsystem to the user interfaces.
- The AES uses linear polarization.
- The AES system uses digital modulation.
- The AES operates through a GSO satellite at least 3° away from any other geostationary satellite operating in the same frequency band and covering the same area.
- The antenna of the AES is directional, with means of tracking the satellites, which can be achieved by using either an active phase array or reflective type configuration.
- These AESs are operating as part of a satellite network used for the distribution and/or exchange of information between users.
- These AESs are controlled and monitored by a Network Control Facility (NCF). The NCF is outside the scope of the present document.
- When on the ground, the AES does not transmit at elevation angles below 7° with respect to the local horizontal plane, except at locations where transmissions below 7° are permitted by the local Administration; (the minimum elevation angle is also limited as per clause 4.2).

The technical requirements in the present document are in two major categories:

- **emission limits:** to protect other radio services and systems from harmful interference generated by the AES in normal use;
- **AES Control and Monitoring Functions (CMF):** to protect other radio services and systems from unwanted transmissions from the AES. The CMF in each AES is capable of answering to commands from the Network Control Facility (NCF) for its supporting satellite network.

The present document applies to the AESs with their ancillary equipment and its various ports, and when operated within the boundary limits of the operational environmental profile declared by the manufacturer.

The technical requirements for the AES in regard to the Power Flux Density (PFD) limits to protect Fixed Service (FS) and Radio Astronomy Service (RAS) are based on annexes B and C of ITU-R Recommendation M.1643 [5] and ECC Report 26 (see bibliography). Furthermore, in relation to the protection of the Fixed Satellite Service (FSS) the technical requirements of the AES take into account annex A of ITU-R Recommendation M.1643 [5].

The present document is intended to cover the provisions of Directive 1999/5/EC (R&TTE Directive) [1] article 3.2, which states that "... radio equipment shall be so constructed that it effectively uses the spectrum allocated to terrestrial/space radio communications and orbital resources so as to avoid harmful interference".

In addition to the present document, other ENs that specify technical requirements in respect of essential requirements under other parts of article 3 of the R&TTE Directive [1] may apply to equipment within the scope of the present document.

NOTE: A list of such ENs is included on the web site at: <http://www.newapproach.org>.

The present document does not cover equipment compliance with relevant civil aviation regulations. In this respect, an AES, for its installation and operation on board an aircraft is subject to additional national or international civil aviation airworthiness certification requirements, for example to EUROCAE ED-14D [4].

2 References

The following documents contain provisions which, through reference in this text, constitute provisions of the present document.

- References are either specific (identified by date of publication and/or edition number or version number) or non-specific.
- For a specific reference, subsequent revisions do not apply.
- For a non-specific reference, the latest version applies.

Referenced documents which are not found to be publicly available in the expected location might be found at <http://docbox.etsi.org/Reference>.

- [1] Directive 1999/5/EC of the European Parliament and of the Council of 9 March 1999 on radio equipment and telecommunications terminal equipment and the mutual recognition of their conformity (R&TTE Directive).
- [2] CISPR 16-1 (2003) (all sub-parts): "Specification for radio disturbance and immunity measuring apparatus and methods; Part 1: Radio disturbance and immunity measuring apparatus".
- [3] IEEE STD 149 (1979): "IEEE Standard Test Procedures for Antennas".
- [4] EUROCAE ED-14D (1997) Change 1 (2000), Change 2 (2001) and Change 3 (2002) (Equivalent to RTCA DO-160D): "Environmental Conditions and Test Procedures for Airborne Equipment".
- [5] ITU-R Recommendation M.1643 (2003): "Technical and operational requirements for aircraft earth stations of aeronautical mobile-satellite service including those using fixed-satellite service network transponders in the band 14-14.5 GHz (Earth-to-space)".

3 Definitions, symbols and abbreviations

3.1 Definitions

For the purposes of the present document, the terms and definitions given in the R&TTE Directive [1] and the following apply:

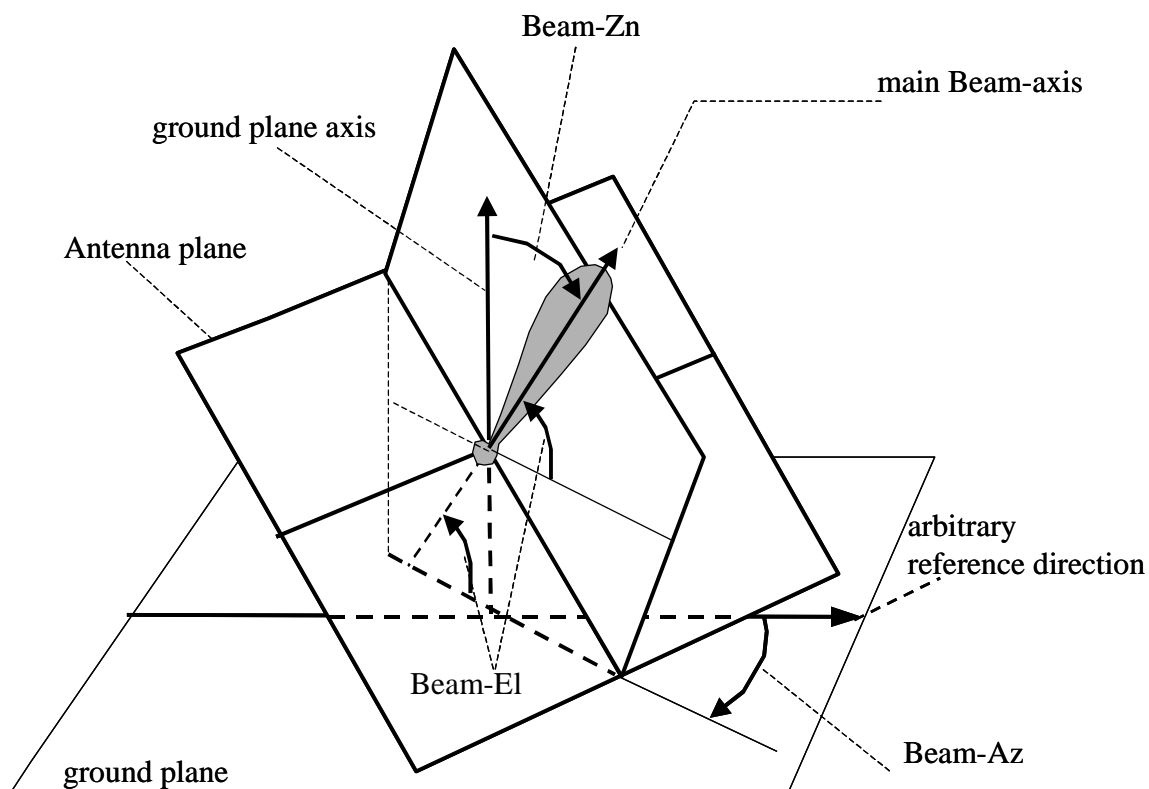

Figure 1b: Reference angles and planes for a passive (e.g. reflector) antenna

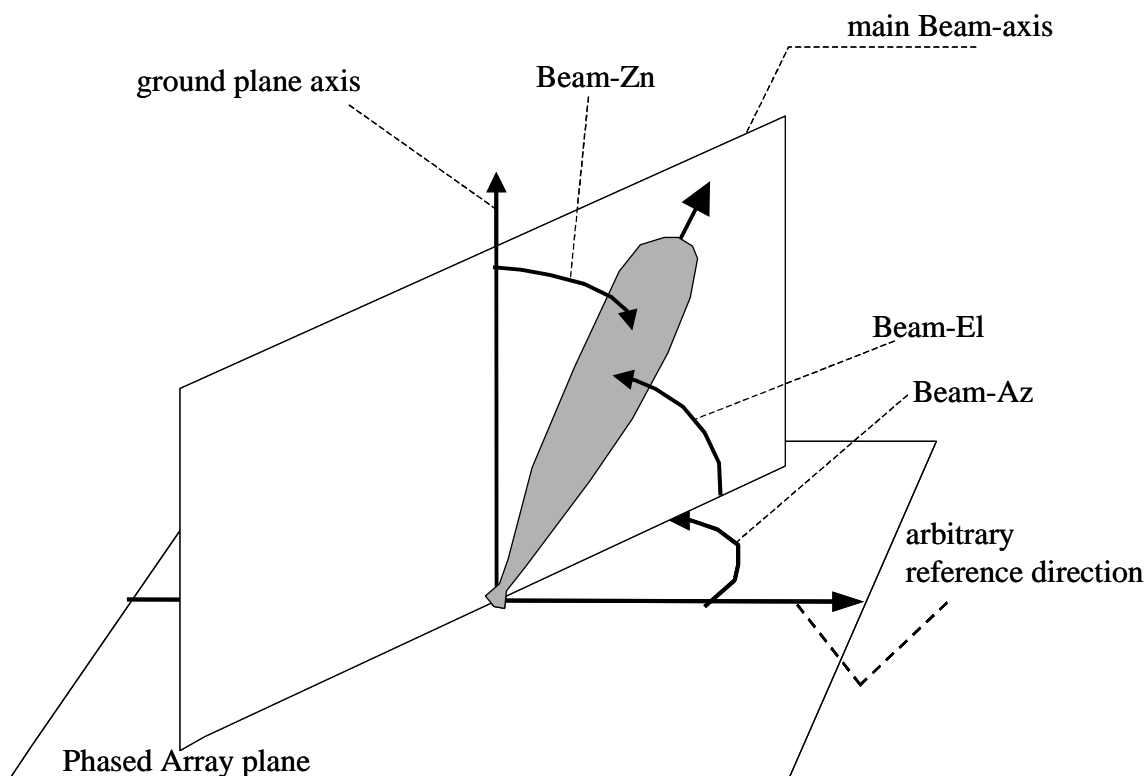

Figure 1c: Reference angles and planes for an active (e.g. phased array) antenna

AMSS network: comprises the AESs, geostationary satellite, LES and NCF

ancillary equipment: equipment used in connection with an AES is considered as ancillary if the three following conditions are met:

- the equipment is intended for use in conjunction with the AES to provide additional operational and/or control features (e.g. to extend control to another position or location); and
- the equipment cannot be used on a stand alone basis, to provide user functions independently of the AES; and
- the absence of the equipment does not inhibit the operation of the AES.

antenna plane: for a passive antenna, plane orthogonal to the main beam axis direction. For a phased array antenna, the antenna plane is the phase array plane

NOTE: See figure 1b.

applicant: manufacturer or his authorized representative within the European Community or the person responsible for placing the apparatus on the market

beam Az angle: angle between an arbitrary reference direction (declared by the manufacturer) within the ground plane and the orthogonal projection of the main beam axis within that plane

NOTE 1: See figures 1b and 1c.

NOTE 2: In case of a rectangular phased array antenna such reference direction may be taken, for example, as the direction parallel to the longer of the two sides.

NOTE 3: When the ground plane axis is vertical and the reference direction oriented towards the north or the south, then the beam Az angle is the main beam azimuth angle.

beam EI angle: angle between the ground plane and the main beam axis

NOTE: See figures 1b and 1c.

beam Zn angle: angle between the ground plane axis and the antenna main beam axis

NOTE: See figures 1b and 1c.

carrier-off state: state in which AES is when either it is authorized by the Network Control Facility (NCF) to transmit but when it does not transmit any signal, or when it is not authorized by the NCF to transmit

carrier-on state: state in which AES is when it is authorized by the NCF to transmit and when it transmits a signal

Control Channel (CC): channel or channels by which AES receive control information from the NCF of their network

NOTE: The CCs are not necessarily on separate RF channels from the RF channels carrying the user data streams.

EIRP_{max}: maximum EIRP capability of the AES as declared by the applicant

environmental profile: range of environmental conditions

Externally Mounted Equipment (EME): those of the modules of the Installable Equipment (IE) which are intended to be mounted externally to the aircraft as stated by the manufacturer

ground plane: for a passive antenna, the plane over which the antenna is mounted

NOTE: This plane can be specified by the manufacturer. For a phased array antenna, the ground plane is the phase array plane (see figure 1b).

ground plane axis: direction orthogonal to the ground plane

NOTE: See figures 1b and 1c.

Installable Equipment (IE): equipment which is intended to be fitted to an aircraft

NOTE: An IE may consist of one or several interconnected modules.

Internally Mounted Equipment (IME): those of the modules of the IE which are not declared by the manufacturer as EME are defined as IME

integral antenna: antenna which may not be removed during the tests according to the applicant's statement

Land Earth Station (LES): earth station in the FSS or, in some cases, in the MSS, located at a specified fixed point or within a specified area on land to provide a feeder-link for the MSS

main beam axis: direction where the antenna gain is maximum

NOTE: See figures 1b and 1c.

manufacturer: authorized representative within the Community or the person responsible for placing the apparatus on the market

nominated Bandwidth (Bn): bandwidth of the AES radio frequency transmission nominated by the applicant

NOTE 1: The nominated bandwidth is centred on the transmit frequency and does not exceed 5 times the occupied Bandwidth (Bo). The nominated bandwidth is within the 14,00 GHz to 14,50 GHz transmit frequency band.

NOTE 2: The nominated bandwidth is wide enough to encompass all spectral elements of the transmission which have a level greater than the specified spurious radiation limits. The nominated bandwidth is wide enough to take account of the transmit carrier frequency stability. This definition is chosen to allow flexibility regarding adjacent channel interference levels which will be taken into account by operational procedures depending on the exact transponder carrier assignment situation.

occupied Bandwidth (Bo): for a digital modulation scheme-the width of the signal spectrum 10 dB below the maximum in-band density

phased array plane: for a phased array antenna, the plane containing the radiating elements, if it exists, otherwise the closest plane to the radiating elements

NOTE: This plane could be specified by the manufacturer (see figure 1c).

removable antenna: antenna which may be removed during the tests according to the applicant's statement

Response Channel (RC): channel by which AES transmit monitoring information to the NCF

rms value: root mean square value of N measured values x_i is the square root of the sum of the square of the values x_i divided by N:

$$rms\ value = \sqrt{\frac{1}{N} \sum_{i=1}^N x_i^2}$$

spurious radiation: any radiation outside the nominated bandwidth

transmission disabled state: state in which AES is when it is not authorized to transmit by the NCF

transmission enabled state: state in which AES is when it is authorized to transmit by the NCF

3.2 Symbols

For the purposes of the present document, the following symbols apply:

dBc	ratio expressed in decibel relative to the absolute carrier EIRP
dB _i	ratio of an antenna gain to the gain of an isotropic antenna, expressed in decibel
dBW	ratio of a power to 1 watt, expressed in decibel
dBpW	ratio of a power to 1 pico watt, expressed in decibel
dB μ V/m	square of the ratio of an electric field to 1 μ V/m, expressed in decibel 20 log (electric field / 1 μ V/m)
θ_{min}	minimum off-axis angle as declared by the manufacturer as defined in clause 4.2.2.2

3.3 Abbreviations

For the purposes of the present document, the following abbreviations apply:

AES	Aircraft Earth Station
AMSS	Aeronautical Mobile Satellite Service
B _o	occupied Bandwidth
B _n	nominated Bandwidth
CC	Control Channel
CISPR	International SPecial Committee on Radio Interference
CMF	Control and Monitoring Function
EC	European Community
EIRP	Equivalent Isotropically Radiated Power
EIRP _{sd}	EIRP spectral density
EME	Externally Mounted Equipment
EN	European Norm
EN-RT	EN Requirements Table
EUROCAE	EUROpean Organization for Civil Aeronautical Electronics
EUT	Equipment Under Test
FEC	Forward Error Correction
FS	Fixed Service
FSS	Fixed-Satellite Service
GSO	Geostationary Satellite Orbit
HPA	High Power Amplifier
IE	Installable Equipment
IEEE	Institute of Electrical and Electronic Engineers
IME	Internally Mounted Equipment

IPR	Intellectual Property Rights
ISO	International Organization for Standardization
LES	Land Earth Station
LNA	Low Noise Amplifier
LNA/D	Low Noise Amplifier/Diplexer
LRU	Line Replaceable Unit
MSS	Mobile Satellite Service
NCF	Network Control Facility
PFD	Power Flux Density
R&TTE	Radio and Telecommunications Terminal Equipment
RAS	Radio Astronomy Service
RC	Response Channel
RF	Radio Frequency
rms	root mean square
RTCA	Radio Technical Committee-Aeronautical
SES	Satellite Earth Stations and Systems
STE	Special Test Equipment
STU	Satellite Terminal Unit
VSAT	Very Small Aperture Terminal

4 Technical requirement specifications

4.1 General

The transmissions from the AES to the Satellite in the 14,00 GHz to 14,50 GHz band fall under a secondary allocation to the Mobile-Satellite Service (MSS), the transmissions should not cause harmful interference to primary services (e.g. the Fixed-Satellite Service (FSS)) and at the same time cannot claim protection from harmful interference from those services. In relation to Radio Astronomy (RA) service in the band 14,47 GHz to 14,50 GHz (whose allocation is on a secondary basis) the transmissions from AES equipment shall not cause unacceptable interference to RA sites operating in this band.

The technical requirements of the present document apply under the operational conditions of the equipment declared by the manufacturer. The operational condition declared by the manufacturer shall include the ranges of the antenna main beam axis directions relative to the antenna ground plane, or any equivalent limit.

4.1.1 Environmental profile

The technical requirements of the present document apply under the environmental profiles for operation of the equipment (EME and IME), which shall be declared by the manufacturer. The equipment (EME and IME) shall comply with all the technical requirements of the present document at all times when operating within the boundary limits of the declared operational environmental profiles and for the environmental conditions (as specified in clause B.3) corresponding to the type of equipment as specified in clause B.2.

4.2 Conformance requirements

4.2.1 General

The applicant shall declare the aircraft model for which the AES is designed.

Under operational conditions an AES may dynamically change the occupied Bandwidth (B_o) and other transmission parameters (e.g. FEC, modulation, symbol rate) of the transmitted signal. For each occupied bandwidth an $EIRP_{max}$ and a nominated Bandwidth (B_n) shall be declared by the applicant. The following specifications apply to the AES for each occupied bandwidth and other transmission parameters.

4.2.2 Spurious radiation

4.2.2.1 Justification

To limit the level of interference to terrestrial and satellite radio services.

4.2.2.2 Specification

The following specifications apply to the AES transmitting at EIRP values up to and including $EIRP_{max}$.

- 1) The AES shall not exceed the limits for radiated interference field strength over the frequency range from 30 MHz to 1 000 MHz specified in table 2.

Table 2: Limits of radiated field strength at a test distance of 10 m in a 120 kHz bandwidth

Frequency range	Quasi-peak limits
30 MHz to 230 MHz	30 dB μ V/m
230 MHz to 1 000 MHz	37 dB μ V/m

The lower limits shall apply at the transition frequency.

- 2) When the AES is in the "Transmission disabled" state, the off-axis spurious Equivalent Isotropically Radiated Power (EIRP) from the AES, in the measurement bandwidth, shall not exceed the limits in table 3, for all off-axis angles greater than a minimum off-axis angle (θ_{min}) declared by the manufacturer.

Table 3: Limits of off-axis spurious EIRP - "Transmission disabled" state

Frequency band	EIRP limit	measurement bandwidth
1,0 GHz to 10,7 GHz	48 dBpW	100 kHz
10,7 GHz to 21,2 GHz	54 dBpW	100 kHz
21,2 GHz to 40,0 GHz	60 dBpW	100 kHz

The lower limits shall apply at the transition frequency.

- 3) When the AES is in the "Transmission enabled" state, i.e. in the carrier-on and carrier-off states, the off-axis spurious EIRP density from the AES, outside the nominated bandwidth, shall not exceed the limits in table 4, for all off-axis angles greater than a minimum off-axis angle (θ_{min}) declared by the manufacturer.

Table 4: Limits of off-axis spurious EIRP "Transmission Enabled" state

Frequency band	EIRP limit	Measurement bandwidth
1,0 GHz to 3,4 GHz	49 dBpW	100 kHz
3,4 GHz to 10,7 GHz	55 dBpW	100 kHz
10,7 GHz to 13,75 GHz	61 dBpW	100 kHz
13,75 GHz to 14,00 GHz	95 dBpW (see note)	10 MHz
14,50 GHz to 14,75 GHz	95 dBpW (see note)	10 MHz
14,75 GHz to 21,2 GHz	61 dBpW	100 kHz
21,2 GHz to 40,0 GHz	67 dBpW	100 kHz
NOTE: This limit may be exceeded in a frequency band which shall not exceed 50 MHz, centred on the carrier frequency, provided that the on-axis EIRP density at the considered frequency is 50 dB below the maximum on-axis EIRP density of the signal (within the nominated bandwidth) expressed in dBW/100 kHz. Furthermore, this limit may be exceeded by a factor of $12 \log(h/2 \text{ km})$ (dB), where the h is the height in km of the aircraft above mean sea level and $h > 2 \text{ km}$, for equipment put on the market before 1 January 2004.		

The lower limits shall apply at the transition frequency.

In the frequency band 28,0 GHz to 29,0 GHz, for any 20 MHz band within which one or more spurious signals exceeding the above limit of 67 dBpW are present, then the power of each of those spurious signals exceeding the limit shall be added in watts, and the sum shall not exceed 78 dBpW.

For AES designed to simultaneously transmit multiple carriers, the limits apply to the sum of the EIRPs of all the simultaneously transmitted carriers.

For tables 3 and 4 the elevation angle of the AES main beam axis with respect to its local horizontal plane shall not be lower than the following minimum elevation angle (ϵ_{\min}) of the AES main beam axis:

$$\epsilon_{\min} = \max(\epsilon_{0 \text{ km}}, \theta_{\min}) - [\max(\epsilon_{0 \text{ km}}, \theta_{\min}) - \epsilon_{2 \text{ km}}] \cdot (h/2 \text{ km}) \quad \text{for } h \leq 2 \text{ km}$$

$$\epsilon_{\min} = \theta_{\min} - \arccos(R_e/(R_e+h)) \quad \text{for } h > 2 \text{ km}$$

where:

R_e mean Earth Radius in km (6 378,14 km);

h is the AES altitude, above the mean sea level, in km. The value of h is set to 0 km when the AES is on the ground;

$\epsilon_{0 \text{ km}}$ is the minimum elevation angle in degrees permitted on the ground: 7° everywhere except in locations where transmissions at lower elevation angles are permitted by the local administrations;

$$\epsilon_{2 \text{ km}} = \theta_{\min} - \arccos(R_e/(R_e+2 \text{ km})) = \theta_{\min} - 1,435^\circ.$$

The elevation angles are positive above the local horizontal plane and negative below it.

4.2.2.3 Conformance tests

Conformance tests shall be carried out in accordance with clause 6.1.

4.2.3 On-axis spurious radiation

4.2.3.1 Justification

To limit the level of interference to satellite radio services.

4.2.3.2 Specification

4.2.3.2.1 "Carrier-on" state

The following specification applies to the AES transmitting at EIRP values up to $EIRP_{\max}$.

- 1) In the 14,00 GHz to 14,50 GHz band the EIRP spectral density of the spurious radiation and outside a bandwidth of 5 times the occupied bandwidth centred on the carrier centre frequency shall not exceed:

$$4 - K \quad \text{dBW in any 100 kHz bandwidth.}$$

- 2) In a bandwidth of 5 times the occupied bandwidth centred on the carrier centre frequency, the EIRP spectral density of the spurious radiation, outside the nominated bandwidth, shall not exceed:

$$18 - K \quad \text{dBW in any 100 kHz bandwidth.}$$

K is the factor that accounts for a reduction on the on-axis spurious radiation level in case of multiple AESs operating on the same frequency.

For AESs which are not expected to transmit simultaneously in a same carrier frequency band, the value of K is 0.

For AESs which are expected to transmit simultaneously in a same carrier frequency band with identical or different EIRPs, the value of K for each EIRP of the AES is given by the following formula:

$$K = -10 \log (EIRP/EIRP_{Aggregate})$$

where:

- EIRP is the on-axis EIRP of the AES within the nominated bandwidth; and
- $EIRP_{Aggregate}$ is the maximum on-axis aggregate EIRP within the nominated bandwidth of the AMSS system towards the satellite;
- $EIRP_{Aggregate}$ shall not be exceeded for more than 0,01 % of the time.

The value of $EIRP_{Aggregate}$ and the operational conditions of the AMSS network shall be declared by the applicant.

NOTE 1: The on-axis spurious radiations, outside the 14,00 GHz to 14,50 GHz band, are indirectly limited by clause 4.2.2.2. Consequently no specification is needed.

NOTE 2: Intermodulation limits inside the band 14,00 GHz to 14,50 GHz are to be determined by system design and are subject to satellite operator specifications.

For AES designed to transmit simultaneously several different carriers (multicarrier operation), the above limits only apply to each individual carrier when transmitted alone.

4.2.3.2.2 "Carrier-off" state and "transmission disabled" state

In the 14,00 GHz to 14,50 GHz band the EIRP spectral density of the spurious radiation (i.e. outside the nominated bandwidth) shall not exceed -21 dBW in any 100 kHz bandwidth.

4.2.3.3 Conformance tests

Conformance tests shall be carried out in accordance with clause 6.2.

4.2.4 Off-axis EIRP emissions density in the nominated bandwidth

4.2.4.1 Justification

Protection of other satellite systems which use the same frequency band.

4.2.4.2 Specification

The following specifications apply to the AES transmitting at EIRP values up to $EIRP_{max}$.

The maximum EIRP in any 40 kHz band in any direction ϕ degrees from the AES antenna main beam axis shall not exceed the following limits within 3° of the geostationary orbit:

33 - 25 log ($\phi + \delta\phi$) - H	dB(W),	where	$2,5^\circ \leq \phi + \delta\phi \leq 7,0^\circ$
+12 - H	dB(W),	where	$7,0^\circ < \phi + \delta\phi \leq 9,2^\circ$
36 - 25 log ($\phi + \delta\phi$) - H	dB(W),	where	$9,2^\circ < \phi + \delta\phi \leq 48^\circ$
-6 - H	dB(W),	where	$48^\circ < \phi + \delta\phi \leq 180^\circ$

where ϕ is the angle, in degrees, between the main beam axis and the direction considered.

The value of $\delta\phi$ (relative to the target satellite) is equal to the rms antenna pointing accuracy.

For AESs designed to transmit always at $EIRP_{max}$, H (in dB) is the maximum number of AESs which may transmit at $EIRP_{max}$ as declared by the manufacturer.

For AESs designed to operate in an AMSS network where the EIRP of each AES is determined by the NCF and where the NCF is in charge of the compliance of the aggregate EIRP density with the above mask, H is the margin as declared by the manufacturer for compliance with the mask, when the AES is transmitting at EIRP_{max}. For NCF which use the antenna pattern or the off-axis EIRP_{sd} the manufacturer shall declare the applicable pattern, the value of H shall be set to 0dB and the AES EIRP density shall not exceed the EIRP density corresponding to the declared pattern.

This margin H or this pattern may be a function of the position of the AES relative to the GSO arc.

The antenna pointing accuracy is the accuracy relative to the nominal GSO satellite direction.

For any off-axis direction in the region outside 3° of the geostationary orbital arc, the above limits may be exceeded by no more than 9 dB (ITU-R Recommendation S.524-7 (see bibliography)). For AES equipment put on the market before 1 January 2004, this latter limit may be further exceeded by no more than 16 dB for directions above the AES horizontal plane only and outside the region within the 3° of the geostationary orbital arc, until such time that an Administration requests protection of operational NGSO systems.

These limits apply within the set of operational main-beam directions of the AES, defined relative to the AES antenna ground plane, and declared by the manufacturer.

The applicant shall declare the maximum on-axis EIRP corresponding to each range of main beam directions and the corresponding envelope of the EIRP density as a function of the off-axis angle. This envelope could also be the EIRP density mask given above. For each range of the main beam directions the above mask in clause 4.2.4.2 shall not be exceeded. The AES shall be able to reduce its on-axis EIRP as required by the NCF in a CC when several AESs are transmitting simultaneously at the same carrier frequency.

4.2.4.3 Conformance tests

Conformance tests shall be carried out in accordance with clause 6.3.

4.2.5 Control and Monitoring Functions (CMF)

For the purpose of the CMF definition, the following states of the AES are defined, without presuming the effective implementation of the AES state machine:

- "Non-valid";
- "Initial phase";
- "Transmission disabled"; and
- "Transmission enabled".

Where:

- In the "Non-valid" state and in the "Transmission disable" state (e.g. under any fault condition), the AES is not allowed to transmit.
- In the "Initial phase" state the AES is only allowed to transmit initial bursts.
- In the "Transmission-enabled" state the AES is allowed to transmit.

NOTE: When the AES is in the "Transmission-enabled" the carrier may have two states: the "Carrier-on" state when the AES transmits a signal and the "Carrier-off" state when the AES does not transmit any signal.

When the AES is not allowed to transmit the EIRP limits for the "Transmission disable" state shall apply.

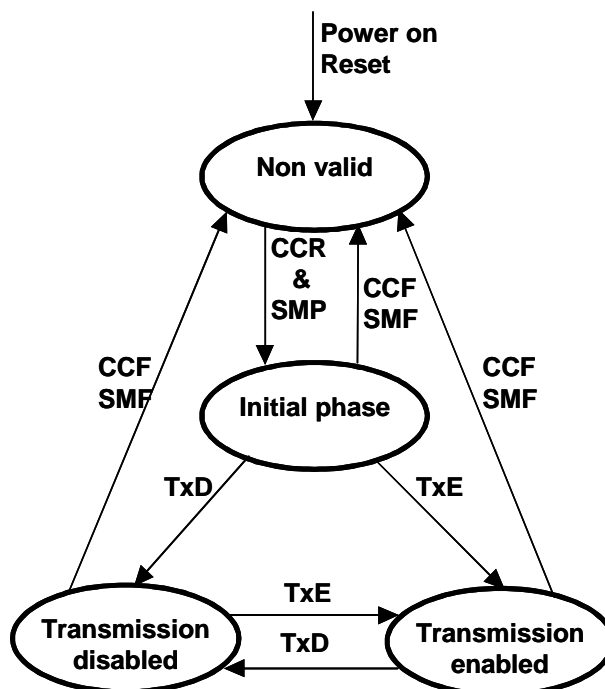

SMP: System Monitoring Pass.
 SMF: System Monitoring Fail.
 TxE: Transmission Enable command.
 TxD: Transmission Disable command.
 CCR: Control Channel correctly Received.
 CCF: Control Channel Reception Failure.

NOTE: From "Transmission disabled" state a TxE command may also result in a transition towards the "Initial phase" state.

Figure 2: Example state transition diagram of the control and monitoring function of the AES

The following minimum set of CMF shall be implemented in AES in order to minimize the probability that they may originate unwanted transmissions that may give rise to harmful interference to other systems.

4.2.5.1 Processor monitoring

4.2.5.1.1 Justification

To ensure that the AES can suppress transmissions in the event of a processor subsystem failure.

4.2.5.1.2 Specification

The AES shall incorporate a processor monitoring function for each of its processors involved in the manipulation of its required traffic and in the control and monitoring functions.

The processor monitoring function shall detect any failure of the processor hardware and software.

After any fault condition occurs, the AES shall enter the carrier-off state within 1 s, if it was in the Transmission enabled state, and within 30 s it shall enter the Transmission disable state until the processor monitoring function has determined that all fault conditions have been cleared.

4.2.5.1.3 Conformance tests

Conformance tests shall be carried out in accordance with clause 6.5.2.

4.2.5.2 Transmit subsystem monitoring

4.2.5.2.1 Justification

To ensure the correct operation of the transmit frequency generation subsystem, and to inhibit transmissions should the subsystem fail.

4.2.5.2.2 Specification

The AES shall monitor the operation of its transmit frequency generation subsystem.

No later than 5 s after any fault condition of the transmit frequency generation subsystem occurs, the AES shall enter the Transmission-disabled state until the transmit subsystem monitoring function has determined that all fault conditions have been cleared.

4.2.5.2.3 Conformance tests

Conformance tests shall be carried out in accordance with clause 6.5.3.

4.2.5.3 Power-on/Reset

4.2.5.3.1 Justification

To demonstrate that the AES achieves a controlled non-transmitting state following the powering of the unit or the occurrence of a reset made by a local operator when this function is implemented.

4.2.5.3.2 Specification

During and following "power on" or a manual reset when this function is implemented, the AES shall remain in the Transmission-disabled state.

4.2.5.3.3 Conformance tests

Conformance tests shall be carried out in accordance with clause 6.5.4.

4.2.5.4 Control Channel (CC) reception

4.2.5.4.1 Justification

To ensure that the AES cannot transmit unless it correctly receives the CC messages from the NCF.

4.2.5.4.2 Specification

- a) Without correct reception of the CC messages from the NCF, the AES shall remain in the Transmission-disabled state.
- b) When in the Transmission enabled state, the AES shall enter the Transmission disabled state immediately after a period not exceeding 30 s without correct reception of the CC messages from the NCF.

4.2.5.4.3 Conformance tests

Conformance tests shall be carried out in accordance with clause 6.5.5.

4.2.5.5 Network control commands

4.2.5.5.1 Justification

These requirements ensure that the AES is capable of:

- a) retaining a unique identification in the network and transmitting it upon reception of an appropriate request;
- b) receiving commands from the NCF through its CC and executing those commands.

4.2.5.5.2 Specification

The AES shall hold, in non-volatile memory, its unique identification code in the network.

The AES shall be capable of receiving through its CC dedicated commands (addressed to the AES) from the NCF, and which contain:

- transmission enable commands, including the transmission parameters (at least the EIRP, the data rate and carrier centre frequency);

NOTE: The transmission parameter may be transmitted by any means (e.g. a value or a reference to a set of values).

- transmission disable commands;
- identification request.

The transmission parameters of the AES shall be only those authorized by the NCF through the CC.

When, any transmission parameter change in a CC message is received by the AES, it shall implement that change within 1 s.

Once a transmission enable command is received the AES is authorized to transmit.

After power-on or reset the AES shall remain in the Transmission disabled state until it receives a transmission enable command. For systems where no transmission enable command is expected after power-on or reset the AES may only transmit initial bursts (see clause 4.2.5.6).

Once a transmission disable command is received, within 1 s the AES shall enter and shall remain in the Transmission disabled state until the transmission disable command is superseded by a subsequent transmission enable command.

The AES shall be capable of transmitting its identification code upon reception of an identification request.

4.2.5.5.3 Conformance tests

Conformance tests shall be carried out in accordance with clause 6.5.6.

4.2.5.6 Initial burst transmission

4.2.5.6.1 General

Restrictions on the initial burst transmissions are necessary to limit disturbance to other services.

4.2.5.6.2 Specification

For AMSS Systems where no transmission enable command is foreseen without request from the AES, in the "Initial phase" state the AES may transmit initial bursts.

- a) The duty cycle of the burst retransmission shall not exceed 0,2 %.
- b) Each burst shall not carry more than 256 data bytes excluding the burst preambles and the FEC coding bits.
- c) The initial burst shall be transmitted at an EIRP up to $EIRP_{max}$.

The requirements for the Transmission enable state shall apply during the transmission of each initial burst.

4.2.5.6.3 Conformance tests

Conformance tests shall be carried out in accordance with clause 6.5.7.

4.2.6 Power Flux Density at the surface of the earth

4.2.6.1 General

The limitation of the Power Flux Density (PFD) at the surface of the Earth shall be controlled either by the AES itself, or by the NCF.

4.2.6.2 Power flux density limits in the 14,00 GHz to 14,50 GHz frequency band

4.2.6.2.1 Justification

In Europe, some countries operate Fixed Service (FS) links in the band 14,25 GHz to 14,50 GHz (shared band with FSS) on a primary basis (i.e. France, Italy and United Kingdom; see ITU Radio Regulations footnotes 5.508a and 5.509a) and Radio Astronomy Service (RAS) in the band 14,47 GHz to 14,50 GHz (shared with the FSS) on a secondary basis (i.e. France, Italy, United Kingdom and Spain; see ITU Radio Regulations footnotes 5.504b and 5.504c).

In other countries outside Europe FS links may operate in other parts of the 14,00 GHz to 14,50 GHz band on a primary basis as per ITU Radio Regulations footnotes 5.505, 5.508, 5.508a and 5.509a and Radio Astronomy Service (RAS) in the band 14,47 GHz to 14,50 GHz on a secondary basis as per ITU Radio Regulations footnotes 5.504b and 5.504c.

Based on the above, there is a requirement for protection of FS systems in the band 14,00 to 14,50 GHz and RAS sites in the band 14,47 GHz to 14,50 GHz from in-band and out-band emissions of AES operating in the band 14,00 GHz to 14,50 GHz on a secondary basis. The specification of protection of FS systems and RAS is based on the Power Flux Density (PFD) limits per AES.

The PFD requirement for protection of FS systems is applicable when the AES is in line of sight with a country employing such FS systems and could be relaxed if the operator of the AES network has an agreement with the Administration of that country.

The PFD requirement for protection of specific RAS sites is applicable when the AES is in line of sight of the specific RAS sites.

Even though the NCF is outside the scope of the present document, within the present clause on PFD limitation, the applicant is required to declare the minimum requirement for a NCF operating the AES and for the purpose of the PFD limitation.

4.2.6.2.2 Specification 1: mode of PFD limitation

Two modes of limitation may be implemented for this PFD limitation:

- a) the "partially remote controlled mode" where the NCF determines that the PFD shall be limited and regularly transmits to the AES the necessary information for the determination and the update of the AES transmission parameters, by the AES itself;
- b) the "full remote controlled mode" where the NCF determines that the PFD shall be limited and regularly transmits all the necessary transmission parameters to the AES.

At least one of these two modes shall be implemented within the AES.

The applicant shall declare:

- the modes of limitation which are implemented within the AES;

- the AES interfaces involved in the PFD limitation:
 - the list of relevant parameters which are collected by the AES for the transmission parameter determination by the AES and the NCF (e.g. the aircraft altitude, latitude, longitude, attitude);
 - the list of these relevant parameters which are used by the AES for the transmission parameter determination;
 - the list of these relevant parameters which are transmitted by the AES to the NCF for the transmission parameter determination;
 - the list of the transmission parameters which are received by the AES from the NCF for the transmission parameter determination;
 - for the collected relevant parameters, the AES interface (s), including the protocols, the timing, the ranges of the values, the speed of the variations and the required accuracies;
 - for the relevant parameters transmitted to the NCF, the AES interface with the NCF, including the protocols and the timing;
 - for the transmission parameter received from the NCF, the AES interface with the NCF, including the protocols and the timing;
 - these declared AES interfaces shall be in accordance with the user documentation.

4.2.6.2.3 Specification 2: Location where to limit the PFD

When the AES is operating in the frequency band from 14,00 GHz to 14,50 GHz and within the line-of-sight of the territory of an Administration where the Fixed Service networks are operating in this frequency band, the PFD produced at the surface of the Earth by emissions from the AES shall be limited as specified in specification 3a. The territory of Administrations where Fixed Service networks are operating in this frequency band are defined by the ITU Radio Regulations footnotes 5.505, 5.508, 5.508a and 5.509a.

When the AES is operating in the frequency band from 14,00 GHz to 14,50 GHz and within the line-of-sight of the RAS site operating in the frequency band 14,47 GHz and 14,50 GHz, the PFD produced at the surface of the Earth by emissions from the AES shall be limited as specified in specification 3b. The Administrations where RAS sites are operating in this frequency band are defined by the ITU Radio Regulations footnotes 5.504b and 5.504c.

For an AES which determines partially where to limit the PFD, based on its location, the AES shall be able to determine where to limit the PFD with the accuracy declared by the applicant.

For AMSS networks where the NCF determines completely or partially where to limit the PFD, based on the AES location, the collection of the relevant parameters by the AES and the exchange of information between the AES and the NCF shall be sufficient for the NCF to determine where to limit the PFD with the accuracy declared by the applicant and to inform in time the AES to limit the PFD.

The determination of the locations where a PFD limitation is necessary, for the protection of the FS or RAS or both, shall take into account the inaccuracy of the AES location and of the country borders or RAS specific sites in the data base used either by the AES or the NCF, as declared by applicant.

4.2.6.2.4 Specification 3: PFD limitation

Specification 3a

When the AES PFD at the surface of the Earth shall be limited, for the protection of FS in the band 14,25 GHz to 14,50 GHz, then the PFD at the surface of the Earth shall not exceed the PFD limits of annex B of ITU-R Recommendation M.1643 [5].

This specification 3a applies in the band 14,25 GHz to 14,50 GHz when the AES is operating in the 14,00 GHz to 14,50 GHz.

Specification 3b

When the AES PFD at the surface of the Earth shall be limited, for the protection of RAS sites in the band 14,47 GHz to 14,50 GHz, then the PFD at the surface of the Earth shall not exceed the PFD limits of annex C of ITU-R Recommendation M.1643 [5].

This specification 3b applies in the band 14,47 GHz to 14,50 GHz when the AES is operating in the 14,00 GHz to 14,50 GHz.

Specification 3c

The above specifications 3a and 3b apply for any AES altitude relative to sea level within the operational altitude range of the AES as declared by the manufacturer. Outside this range of altitude the AES shall not transmit.

The above specifications 3a and 3b apply for the relevant parameters within the ranges declared by the applicant. In case of a relevant parameter out of the specified range AES shall not transmit.

The relationship between the PFD, the EIRP and the altitude (h) of the AES is given in annex D of ITU-R Recommendation M.1643 [5].

For an AES which determines partially where to limit the PFD, based on its location, the AES shall be able to limit the PFD as specified above taking into account the inaccuracies declared by the applicant.

For AMSS networks where the NCF determines completely or partially where to limit the PFD, based on the AES location, the collection of relevant parameters by the AES and the exchange of information between the AES and the NCF shall be such that with the information received from the NCF the AES is able to limit the PFD as specified above taking into account the inaccuracies declared by the applicant.

4.2.6.2.5 Specification 4: Fault conditions

Any collection or transmission of the relevant parameters to the NCF which have not been completed correctly within the required delay(s) declared by the manufacturer, shall be considered as a fault condition. In this case the AES shall enter the "Transmission disabled" state.

Any transmission parameter not received or not correctly received from the NCF within the required delay declared by the manufacturer shall be considered as a fault condition. In this case the AES shall enter the "Transmission disabled" state.

4.2.6.2.6 Conformance tests

Conformance tests shall be carried out in accordance with clause 6.4.

5 Testing for compliance with technical requirements

5.1 Environmental conditions for testing

Tests defined in the present document shall be carried out at representative points within the boundary limits of the declared operational environmental profile (see annex B).

5.2 Essential radio test suites

The essential radio test suites for an AES are given in clause 6.

6 Test methods

6.0 General

The AES will consist of equipment located within the interior of an aircraft fuselage (Internally Mounted Equipment or IME) and mounted on the exterior of the aircraft (Externally Mounted Equipment or EME). In addition, the externally mounted equipment will be designed and tested to meet the requirements given in clause 4, as tested per the procedures in this clause.

Formal testing will be accomplished under the direction of a test procedure. This test procedure will have been created specifically for testing the exact equipment intended for qualification or certification. The test procedure will describe or provide reference to all expected test conditions and parameters, including cable harness construction details, all equipment set-up, interconnect, placement and configuration details, instructions for operating the device and for determining its proper operation, and any necessary instructions for performing the test measurements.

Measurement Accuracy: The values of measurement uncertainty associated with each measurement parameter apply to all of the test cases described in the present document. The measurement uncertainties shall not exceed the values shown in tables 5 and 6.

Table 5: Measurement uncertainty

Measurement parameter	Uncertainty
Radio frequency	±10 kHz
RF power	±0,75 dB
Conducted spurious	±4 dB
Radiated spurious	±6 dB
Antenna on-axis gain	±2 dB

Table 6: Measurement uncertainties for antenna gain pattern

Gain relative to the antenna on-axis gain	Uncertainty
> -3 dB	±0,3 dB
-3 dB to -20 dB	±1,0 dB
-20 dB to -30 dB	±2,0 dB
-30 dB to -40 dB	±3,0 dB

Monitoring Function: To enable the performance tests to be carried out, the use of a NCF Control Channel or a Special Test Equipment (STE) made available by the applicant or system provider, may be necessary. Since this STE will be specific for the particular system, it is not possible to provide detailed specifications in the present document. However, the following baseline is provided:

- if the AES shall receive a modulated carrier from the satellite in order to transmit, then special test arrangements are required to simulate the satellite signal, thus enabling the system to transmit, thereby allowing measurement of transmission parameters;
- any characteristic of these special test arrangements which may have direct or indirect effects on the parameters to be measured shall be clearly stated by the applicant.

The test procedures given in clause 6 may be replaced by other equivalent procedures provided that the results are proven to be as accurate as those obtained according to the specified method. Because each applicant's equipment may be different, then different test methods can be suggested and proposed by the applicant to account for the different equipment characteristics. Specific test procedures shall be fully documented in the test procedure and test report.

All tests with carrier-on shall be undertaken with the transmitter operating at maximum power and with the maximum transmit burst rate, where applicable, which shall be declared by the applicant.

If the Equipment Under Test (EUT) has had hardware and/or software modification(s) performed by the applicant for these tests, then full documentation of such modification(s) shall be provided to prove that the modification(s) will simulate the required test condition. Such modification(s) shall be proved to allow the AES to operate without its main characteristics being changed.

All technical characteristics and operational conditions declared by the applicant shall be entered in the test report.

6.1 Spurious radiation

6.1.1 Test method

An EUT comprises all of the exterior mounted Line Replaceable Units (LRUs), including the antenna and radome (if any). These LRUs shall be interconnected by the longest cable expected to be seen in service as recommended by the applicant, or, if that is unknown, by a 10 m cable. The connecting cable between the internal and the external units shall be the same type as recommended by the applicant in the installation manual. The type of cable used shall be entered in the test procedure and the test report.

Because an AES antenna is typically attached directly to the skin of the airplane fuselage, and is usually the primary aperture for externally generated emissions, testing without an antenna will not be an option, herein.

The internal unit(s) shall be terminated with matched impedances at the interface ports if there is no associated equipment connected to such ports and if recommended by the applicant in the user documentation.

Antennas

For frequencies up to 80 MHz the measuring antenna shall be calibrated according to the requirements of CISPR 16-1 [2].

For frequencies between 80 MHz and 1 000 MHz the measuring antenna shall be calibrated according to the requirements of CISPR 16-1 [2].

For frequencies above 1 000 MHz the antenna shall be a horn radiator of known gain/frequency characteristics. When used for reception, the antenna and any associated amplification system shall have an amplitude/frequency response within ± 2 dB of the combined calibration curves across the antenna's measurement frequency range. The antenna is mounted on a support capable of allowing the antenna to be used in either horizontal or vertical polarization and at the specified height.

6.1.1.1 Up to 1 000 MHz (see clause 4.2.2.2, table 2)

6.1.1.1.1 Test site

The test shall be performed either in an open area test site, a semi-anechoic chamber, or an anechoic chamber. Ambient noise levels shall be at least 6 dB below the applicable unwanted emissions limit.

The open area test site shall be flat, free of overhead wires and nearby reflecting structures, sufficiently large to permit aerial placement at the specified measuring distance and provide adequate separation between aerial, test unit and reflecting structures, according to the specification of CISPR 16-1 [2].

For both the open area test site and the semi-anechoic chamber a metal ground plane shall be inserted on the natural ground plane and it shall extend at least 1 m beyond the perimeter of the EUT at one end and at least 1 m beyond the measurement antenna at the other end.

The distance between the EUT and measuring antenna should be 10 m. For measurements at a different distance an inverse proportionality factor of 20 dB per decade shall be used to normalize the measured data to the specified distance for determining compliance. Care should be taken in measurement of large test units at 3 m at frequencies near 30 MHz due to near field effects.

6.1.1.1.2 Measuring receivers

The measuring receiver will either be located outside the test area such that no radiations from the measuring receiver in the band of interest are detectable at the measuring antenna, or the test area will be calibrated without the EUT to determine the contribution of the receiving equipment active elements.

Measuring receivers shall conform to the following characteristics:

- the response to a constant amplitude sine wave signal shall remain within ± 1 dB across the frequency range of interest;
- quasi-peak detection shall be used in a -6 dB bandwidth of 120 kHz;
- the receiver shall be operated below the 1 dB compression point.

6.1.1.1.3 Procedure

- a) The EUT shall be all exterior mounted LRUs.
- b) The EUT shall be in the carrier-on state.
- c) The EUT shall be rotated in azimuth through 360° in minimum steps of 45° and, except in an anechoic chamber, the measuring antenna height simultaneously varied from 1 m to 4 m above the ground plane. Alternatively, the measuring antenna may be moved around the EUT at a fixed distance from the EUT.
- d) All identified spurious radiations shall be measured and noted in frequency and level.
- e) The boresight of the antenna shall be pointing at zenith, i.e. upwards.

6.1.1.2 Above 1 000 MHz (see clause 4.2.2.2, tables 3 and 4)

The spectrum analyser resolution bandwidth shall be set to the specified measuring bandwidth or as close as possible. If the resolution bandwidth is different from the specified measuring bandwidth, a bandwidth correction shall be performed for the noise-like wideband spurious emissions.

Tests shall be performed in two stages for both the carrier-on and carrier-off states:

- Procedure a) Identification of the significant frequencies of spurious radiation;
- Procedure b) Measurement of radiated power levels of identified spurious radiation.

6.1.1.2.1 Identification of the significant frequencies of spurious radiation

6.1.1.2.1.1 Test site

The identification of frequencies emitting from the EUT shall be performed either in an anechoic chamber, an open area test site or a semi-anechoic chamber with the test antenna close to the EUT and at the same height as the volume centre of the EUT. See also figure 3 for the AES positioning.

6.1.1.2.1.2 Procedure

- a) The EUT shall be in the carrier-off state.
- b) The main beam of the antenna shall have an angle of elevation equal to θ_{\min} .
- c) The measuring receivers shall scan the frequency band while the EUT revolves or the test antenna is moved around the EUT.
- d) The EUT shall be rotated in azimuth through 360° in minimum steps of 45° and the frequency of any spurious signals noted for further investigation. Alternatively, the measuring antenna may be moved around the EUT at a fixed distance from the EUT.
- e) The test shall be repeated with the test antenna being in the opposite polarization.

- f) The test shall be repeated in the carrier-on state while transmitting one modulated carrier at maximum power.

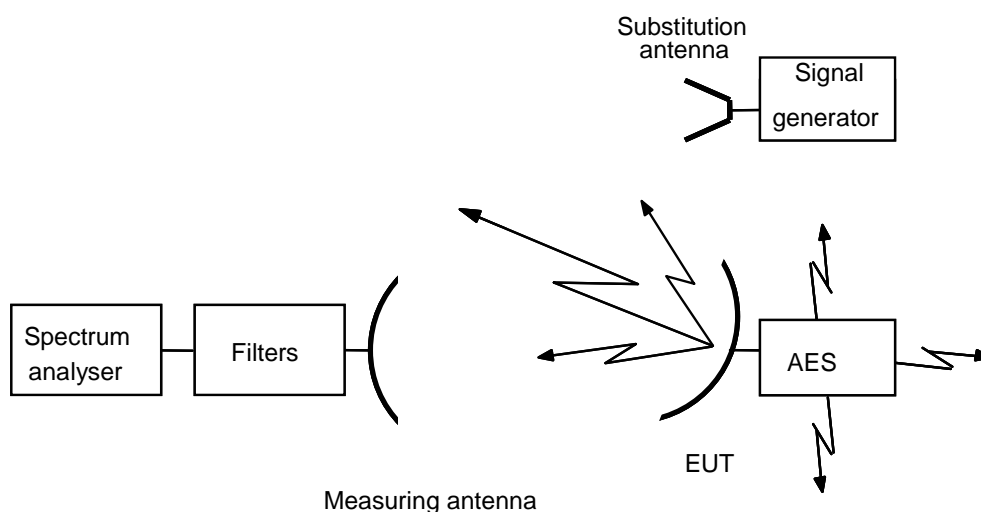

Figure 3: Test arrangement-spurious radiation measurement above 1 000 MHz for an EUT with antenna

6.1.1.2.2 Measurement of radiated power levels of identified spurious radiation

6.1.1.2.2.1 Test site

The measurement of each spurious radiation noted during procedure a) of the test shall be performed on a test site that is free from reflecting objects, i.e. either an open-area test site, a semi-anechoic chamber or an anechoic chamber. See also figure 3 for the AES positioning.

6.1.1.2.2.2 Procedure

- a) The test arrangement shall be as shown in figure 3.
- b) The EUT shall be installed such that if there are more than one LRU under simultaneous test, they are separated by about 1 m to 2 m. The height at which the EUT is tested will be determined by the manufacturer. The interconnection cable shall be maintained by non-conductive means at a height from the ground plane simulating the worst-case expected airplane installation for wiring relative to the fuselage. For the test arrangement shown in figure 3 the main beam of the antenna shall have an angle of elevation equal to θ_{\min} and be oriented away from the geostationary orbit, or be inhibited by placing RF absorbing panels in that direction (this is to minimize interference towards the GSO satellites while the test is performed). For antennas designed for minimum off-axis gain in the direction of the geostationary orbit plane, the plane containing the larger cut of the main lobe shall be set vertical.
- c) The measuring antenna shall be positioned at a distance from the EUT (e.g. 3 m, 5 m, 10 m) relevant to the applied test site. The measuring antenna shall be adjusted in height and the EUT rotated or the measuring antenna move around the EUT, while the EUT is in the appropriate carrier condition. For the maximum response on the associated spectrum analyser at each spurious frequency previously identified, the response level shall be noted. The adjustment in height of the measuring antenna does not apply when an anechoic chamber is being used. The measuring antenna shall not enter the θ_{\min} off-axis cone around the main beam direction.
- d) The investigation shall be repeated with the measuring antenna in the opposite polarization and the response level similarly noted.
- e) The EUT shall be replaced by the substitution antenna to which is connected a signal generator. The main beam axes of the measuring and substitution antennas shall be aligned. The distance between these antennas shall be the distance determined under test c).
- f) The substitution and measuring antennas shall be aligned in the polarization which produced the larger response between the EUT and the test antenna in steps c) and d).

- g) The output of the generator shall be adjusted so that the received level is identical to that of the previously noted largest spurious radiation, for each frequency identified as a spurious signal.
- h) The output level of the signal generator shall be noted. The EIRP of the spurious radiation is the sum, in dB, of the signal generator output plus the substitution antenna isotropic gain minus the interconnection cable loss.
- i) For equipment which take account of the relaxation factor $12 \log (h/2 \text{ km})$ (dB) and which are put on the market before 1 January 2004, the test shall be executed at AES altitudes equal to 0 km, 2 km, 4 km, 8 km and 12 km, or to the closest altitude within the range of operational altitudes as declared by the manufacturer.

6.2 On-axis spurious radiation

6.2.1 Test method

6.2.1.1 Test site

There are no requirements for the test site to be used for this test.

6.2.1.2 Method of measurement

6.2.1.2.1 General

The tests shall be undertaken with the transmitter operating at $EIRP_{max}$.

For AES equipment for which measurements at the antenna flange are not possible or not agreed by the applicant, the measurements shall be performed with a test antenna.

For AES equipment for which measurements at the antenna flange are possible and agreed by the applicant, the measurements shall be performed at the antenna flange. The EUT is the AES with its antenna comprising both the internal and external units.

6.2.1.2.2 Method of measurement at the antenna flange

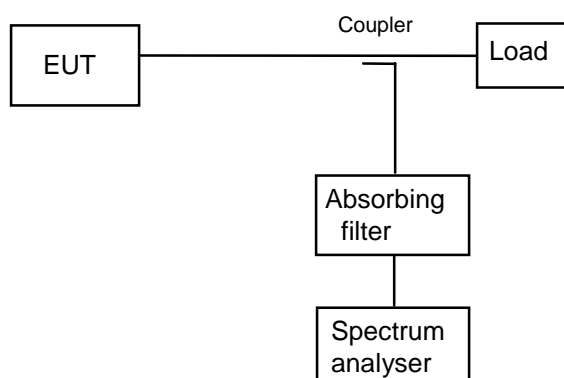

Figure 4: Test arrangement - on-axis spurious radiation measurements at the antenna flange

- a) The test arrangement shall be as shown in figure 4. In order to protect the Spectrum Analyser while ensuring the necessary measurement accuracy, particularly close to the carrier, if an absorbing filter is used it shall be tuned to the transmit carrier frequency.
- b) The EUT shall transmit one modulated carrier continuously, or at its maximum burst rate where applicable, centred on a frequency as close to the lower limit of the operating frequency band of the EUT as possible. The EUT shall be operated at the highest normal operating EIRP. The frequency range 14,00 GHz to 14,50 GHz shall be investigated.

- c) Due to the proximity of the carrier the spectrum analyser resolution bandwidth shall be set to a measurement bandwidth of 3 kHz, or as close as possible. If the measurement bandwidth is different from the specified measurement bandwidth, a bandwidth correction factor shall be performed for noise-like wideband spurious radiation.
- d) To obtain the on-axis spurious EIRP, the antenna transmit gain shall be added to any figure obtained in the above measurement and any correction or calibration factor summated with the result. The antenna gain shall be as measured in clause 6.3.3.2 at the closest frequency to the spurious frequency.
- e) The tests in b) to d) shall be repeated with a transmit frequency in the centre of the operating frequency band.
- f) The tests in b) to d) shall be repeated with a transmit frequency as close to the upper limit of the operating frequency band of the EUT as possible.
- g) The test shall be repeated in the carrier-off state.
- h) The test shall be repeated in the "transmission disabled state".

6.2.1.2.3 Method of measurement with a test antenna

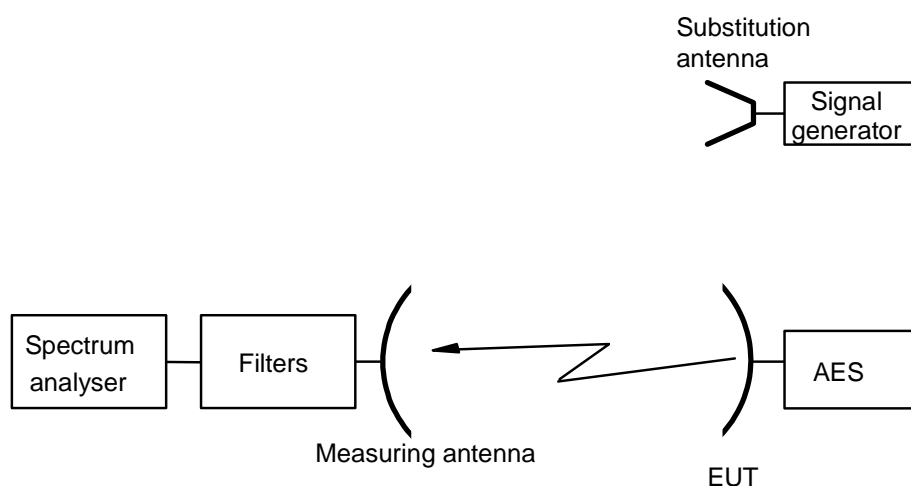

Figure 5: Test arrangement-on-axis spurious radiation measurements for an EUT with antenna

- a) The test arrangement shall be as shown in figure 5.
- b) The EUT shall be installed such that the LRUs are at a height between 0,5 m and 1,0 m on a turntable. If there are more than one LRU in the EUT, they shall be separated by 1 m to 2 m. The interconnection cable shall be maintained by non-conductive means at a height between 0,5 m and 1,0 m.
- c) The spectrum analyser resolution bandwidth shall be set to the specified measuring bandwidth or as close as possible. If the resolution bandwidth is different from the specified measuring bandwidth, a bandwidth correction factor shall be performed for noise-like wideband spurious radiation.
- d) The EUT shall transmit one modulated carrier continuously, or at its maximum burst rate where applicable, centred on a frequency as close to the lower limit of the operating frequency band of the EUT as possible. The EUT shall be operated at $EIRP_{max}$. The frequency range 14,00 GHz to 14,50 GHz shall be investigated and each spurious frequency shall be noted.
- e) Due to the proximity of the carrier the spectrum analyser resolution bandwidth shall be set to a measurement bandwidth of 3 kHz, or as close as possible. If the measurement bandwidth is different from the specified measurement bandwidth, a bandwidth correction factor shall be performed for noise-like wideband spurious radiation.

- f) The measuring antenna shall be positioned at a distance from the EUT (e.g. 3 m, 5 m, 10 m) relevant to the applied test site and shall be aligned with the EUT antenna for the transmit frequency. The measuring antenna shall be adjusted in height, while the EUT is in the appropriate carrier condition, for a maximum response on the associated spectrum analyser at each spurious frequency previously identified, this response level shall be noted. The adjustment in height of the measuring antenna does not apply when an anechoic chamber is being used.
- g) The EUT shall be replaced by a representative substitution antenna to which is connected a signal generator. The main beam axes of the measuring and substitution antennas shall be aligned. The distance between these antennas shall be the distance determined under test f).
- h) The substitution and measuring antennas shall be aligned in the polarization that produced the largest response between the EUT and the test antenna.
- i) The output of the generator shall be adjusted so that the received level is identical to that of the previously noted largest spurious radiation.
- j) The output level of the signal generator shall be noted. The EIRP of the on-axis spurious radiation is the sum, in dB, of the signal generator output plus the substitution antenna isotropic gain minus the interconnection cable loss.
- k) The tests in d) to j) shall be repeated with a transmit frequency in the centre of the operating frequency band.
- l) The tests in d) to j) shall be repeated with a transmit frequency as close to the upper limit of the operating frequency band of the EUT as possible.
- m) The test shall be repeated in the carrier-off state.
- n) The test shall be repeated in the "transmission disabled state" state.

6.3 Off-axis EIRP emissions density in the nominated bandwidth

6.3.1 General

Conformance shall be determined from:

- a) the measurement of the rms pointing accuracy;
- b) the measurement of the off-axis EIRP.

For the measurement of the off-axis EIRP, the EUT shall be either with or without its antenna:

- For AES equipment with passive antenna and for which measurements at the antenna flange are possible and agreed by the manufacturer, the EUT shall be without the antenna. The test shall be performed in three stages:
 - a) the measurement of the transmitter output power density (dBW/40 kHz);
 - b) the measurement of the antenna transmit gain (dBi);
 - c) the measurement of the antenna transmit radiation patterns (dBi).
- For AES equipment with active antenna or with passive antenna and for which measurements at the antenna flange are not possible or not agreed by the manufacturer, the EUT shall be fitted with the antenna. The test shall be performed in three stages:
 - a) the measurement of the maximum EIRP density per 40 kHz ratio relative to the EIRP (dBc/40 kHz);
 - b) the measurement of the maximum on-axis EIRP (dBW);
 - c) the measurement of the antenna transmit radiation patterns (dBi).

6.3.2 rms antenna pointing accuracy

6.3.2.1 Method of measurement

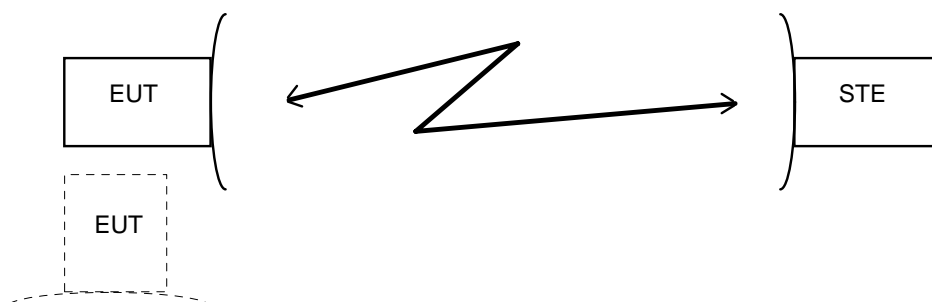

Figure 6: Test arrangement - rms pointing accuracy

- The equipment shall be arranged as shown in figure 6 at a distance between the STE and EUT such that the two antennas are in the far field of each other, with the EUT main beam set away from the STE. The beam Zn-angle and the beam Az-angle shall be set to 0°.
- The level of the signal radiated by the STE shall be adjusted so that the EUT receives a power density corresponding to the signal to noise ratio declared by the manufacturer. This power density shall be representative of those expected for 95 % of the AES within the network and typically will be 2 dB above the edge of coverage figures for which the AES is designed to operate.
- The EUT shall be switched-on and allow the EUT to acquire the pointing position towards the STE.
- The pointing error shall be measured five times and recorded. The method of measurement to be used shall be agreed between the manufacturer and the test house.
- The rms value of this pointing error shall be calculated with the above 5 measurements x_i :

$$rms\ value = \sqrt{\frac{1}{5} \times \sum_{i=1}^{i=5} x_i^2}$$

- The EUT shall be switched-off.
- The EUT shall be repointed to cause a change in main beam pointing angle of at least 60 degrees.
- The tests in c) to f) shall be repeated 8 more times.
- The value of rms pointing accuracy shall be taken to be the largest value of the 9 rms values recorded.

6.3.3 Measurement of the off-axis EIRP without the antenna

6.3.3.1 Transmitter output power density

For purpose of the test, the EUT comprises all of the equipment (Installable Equipment; IE) noted up to the antenna flange:

- the EME;
- the IME;
- a connection cable between IME and EME unit;
- the necessary power supply cables and any other cable ensuring a proper functioning of the terminal.

Where the EUT is so designed that it is not normally possible to make a direct connection to the feed at the antenna flange, or connecting point, the manufacturer shall provide a means of so doing specifically for the test AES.

6.3.3.1.1 Method of measurement

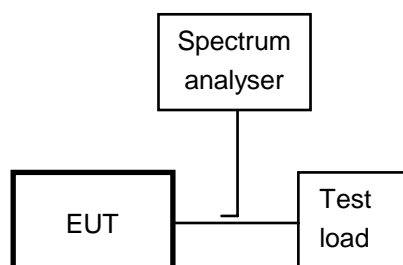

Figure 7: Test arrangement - transmit output power density measurement

- a) The EUT shall be connected to a test load as shown in figure 7.
- b) The test be carried out with the transmit signal of the operational waveform which carries a pseudorandom data stream, the maximum power density supplied to the antenna flange shall be measured in dBW/40 kHz. The coupling factor of the test coupler at the test frequency and the attenuation of any necessary waveguide adapter shall be taken into account. The resolution bandwidth of the spectrum analyser shall be set as close as possible to the specified measuring bandwidth. If the resolution bandwidth is different from the specified bandwidth then a bandwidth correction factor shall be performed.

6.3.3.2 Antenna transmit gain

6.3.3.2.1 General

For the purpose of the present document, the antenna transmit gain is defined as the ratio, expressed in decibels, of the power that would have to be supplied to the reference antenna, i.e. an isotropic radiator isolated in space, to the power supplied to the antenna being considered, so that they produce the same field strength at the same distance in the same direction. Unless otherwise specified the gain is for the direction of maximum radiation.

For the purpose of this test the EUT is defined as that part of the AES that comprises the antenna and its flange. The EUT includes an enclosure of equal weight/distribution to any electrical equipment normally housed within the antenna (see clause 6.3.3.1 regarding this requirement).

6.3.3.2.2 Test site

This test shall be performed on either an outdoor far-field test site or compact test range. However, if the near-field scanner technology to convert near-field measurements to far-field results is proven and sufficiently accurate by reference to tests taken in both regions then antenna measurements may be taken in the near field.

6.3.3.2.3 Method of measurement

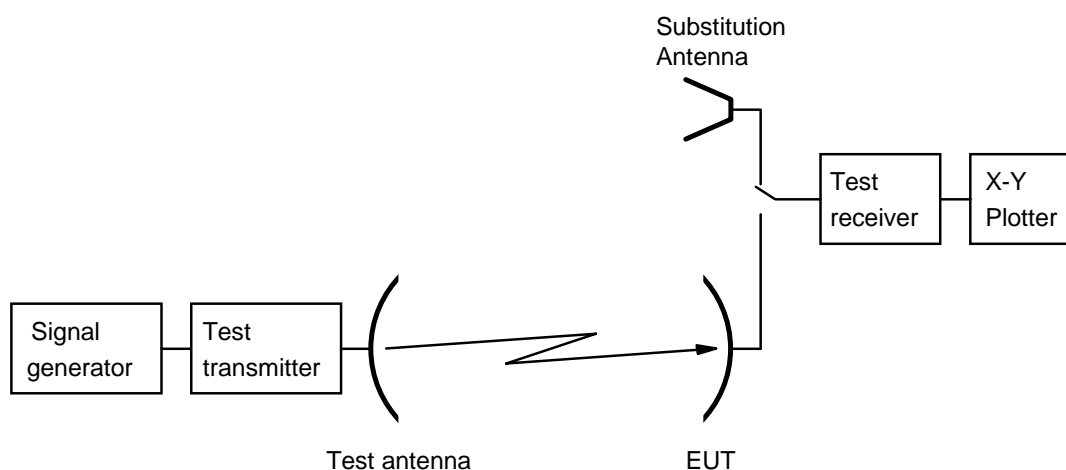

Figure 8: Test arrangement - antenna transmit gain measurement

- a) The test arrangement shall be as shown in figure 8 with the EUT connected to the test receiver. A signal proportional to the angular position from the servomechanism shall be applied to the X-axis and the signal level from the test receiver shall be applied to the Y-axis of the plotter.
- b) The main beam axis shall be pointed horizontal towards the STE.
- c) The initial E-plane of the test signal radiated by the test transmitter through its antenna shall be horizontal. The EUT main beam axis shall be aligned with the main beam axis of the test transmitter. The EUT antenna or its polarizer shall be rotated around its main beam axis such that its E-plane coincides with the E-plane of the test transmitter.
- d) After any change of the E-plane of the test signal, the EUT antenna shall be rotated around its main beam axis such that its E-plane coincides with the E-plane of the test transmitter.
- e) The frequency of the test signal shall be set 5 MHz above the bottom of the lowest frequency band declared by the manufacturer.
- f) The EUT shall be aligned to maximize the received signal and the X-Y plotter adjusted to give the maximum reading on the chart.
- g) The EUT shall be driven in azimuth in one direction through 10°.
- h) The pattern measurement is then obtained by driving the EUT in azimuth back through boresight to 10° the other side with the plotter recording the results.
- i) The EUT shall be replaced by the substitution antenna and the received signal level maximized.
- j) This level shall be recorded on the X-Y plotter.
- k) The substitution antenna shall be driven in azimuth as in f) and g).
- l) The gain of the EUT shall be calculated from:

$$G_{\text{EUT}} = L_1 - L_2 + C$$

where:

- G_{EUT} is the gain of the EUT (dBi);
- L_1 is the level obtained with the EUT (dB);
- L_2 is the level obtained with the substitution antenna (dB);
- C is the calibrated gain of the substituted antenna at the test frequency (dBi).

- m) The tests in e) to l) shall be repeated with the frequency changed to the middle of the lowest frequency band declared by the manufacturer.
- n) The tests in e) to l) shall be repeated with the frequency changed to 5 MHz below the top of the lowest frequency band declared by the manufacturer.
- o) The tests in d) to n) may be performed simultaneously.
- p) The tests in c) to p) shall be repeated with the E-plane vertical.
- q) The tests in c) to p) shall be repeated with the E-plane $+45^\circ$ to the horizontal plane.
- r) The tests in c) to p) shall be repeated with the E-plane -45° to the horizontal plane.
- s) The tests in b) to r) shall be repeated for all frequency bands declared by the manufacturer.

6.3.3.3 Antenna transmit radiation patterns

6.3.3.3.1 General

For the purpose of the present document, the antenna transmit radiation patterns are diagrams relating field strength to direction relative to the pointing angle of the antenna at a constant large distance from the antenna.

For the purpose of this test the EUT is defined as that part of the AES which comprises the antenna and its flange. The antenna includes the parabolic reflector, feed, support struts and an enclosure of equal weight/distribution to any electrical equipment normally housed with the feed at the antenna focal point (see clause 6.3.3.1 regarding this requirement).

6.3.3.3.2 Test site

This test shall be performed on either an outdoor far-field test site or compact test range. However, if the near-field scanner technology to convert near-field measurements to far-field results is proven and sufficiently accurate by reference to tests taken in both regions then antenna measurements may be taken in the near field.

6.3.3.3.3 Method of measurement

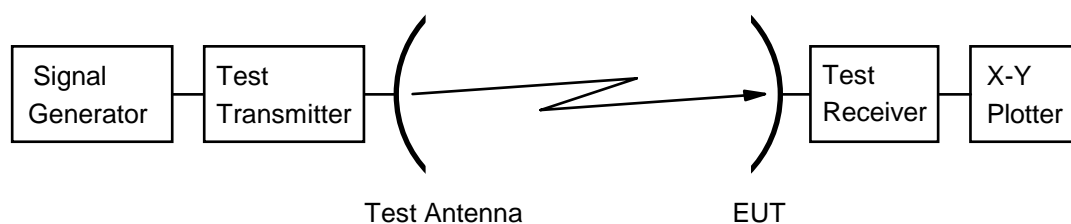

Figure 9: Test arrangement - antenna transmit radiation pattern measurement

- a) The test arrangement shall be as shown in figure 9 with the EUT connected to the test receiver. A signal proportional to the angular position from the servomechanism shall be applied to the X-axis and the signal level from the test receiver shall be applied to the Y-axis of the plotter.
- b) The main beam axis shall be pointed horizontal towards the STE.
- c) The initial E-plane of the test signal radiated by the test transmitter through its antenna shall be horizontal. The EUT main beam axis shall be aligned with the main beam axis of the test transmitter. The EUT antenna or its polarizer shall be rotated around its main beam axis such that its E-plane coincides with the E-plane of the test transmitter.
- d) After any change of the E-plane of the test signal, the EUT antenna shall be rotated around its main beam axis such that its E-plane coincides with the E-plane of the test transmitter.

- e) The frequency of the test signal shall be set 5 MHz above the bottom of the lowest frequency band declared by the manufacturer.
- f) The EUT shall be aligned to maximize the received signal and the X-Y plotter adjusted to give the maximum reading on the chart.
- g) The EUT shall be driven in azimuth to -180° .
- h) The transmit pattern measurement is then obtained by driving the EUT in azimuth through from -180° to $+180^\circ$ with the plotter recording the results. Measurements may be excluded where the radiation pattern from the antenna is fully blocked by the aircraft fuselage for the models declared by the manufacturer. Exclusions shall be noted in the test report.
- i) The tests in d) to h) shall be repeated with the frequency changed to the middle of the lowest frequency band declared by the manufacturer.
- j) The tests in d) to h) shall be repeated with the frequency changed to 5 MHz below the top of the lowest frequency band declared by the manufacturer.
- k) The tests in d) to j) may be performed simultaneously.
- l) The tests in d) to k) shall be repeated with the E-plane being vertical.
- m) The tests in d) to k) shall be repeated with the E-plane at $+\alpha$ to the vertical plane. α is defined as the worst-case angle ($^\circ$) between the horizontal plane and the geostationary orbital arc, as seen from the range of latitudes as declared by the manufacturer.
- n) The tests in d) to k) shall be repeated with the E-plane at $-\alpha$ to the horizontal. α is as defined in m).
- o) The tests in c) to n) shall be repeated for all frequency bands declared by the manufacturer.

6.3.3.4 Computation of results

The results shall be computed by producing a "mask" to the specified limits with the reference level being equal to the sum of the transmitter output power density and the on-axis gain of the antenna. The mask shall be a function of ϕ and shall take account of the value $\delta\phi$ equal to the rms of the measured pointing accuracy. This reference shall then be placed on the maximum point of the plot obtained from the transmit radiation pattern measurement, so as to ascertain that the off-axis EIRP density is within the mask, and thus conforming to the specification.

6.3.4 Measurement of the off-axis EIRP with the antenna

6.3.4.1 General

The requirements set out in clauses 6.1.1 to 6.1.3.1.2 for the measurements above 1 000 MHz shall apply.

6.3.4.2 Maximum EIRP density per 40 kHz ratio relative to the EIRP

For purpose of the test, the EUT shall be the AES fitted with its antenna.

6.3.4.2.1 Method of measurement

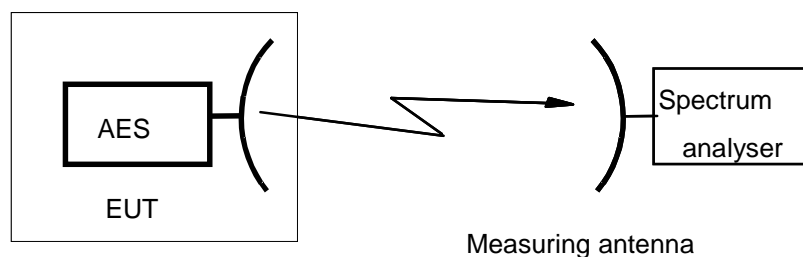

Figure 10: Test arrangement - radiated power density measurement

- The test arrangement shall be as shown in figure 10, both antennas being in line of sight of each other.
- The test be carried out with the transmit signal of the operational waveform which carries a pseudorandom data stream. The transmission shall be continuous where possible.
- The resolution bandwidth of the spectrum analyser shall be set larger but as close as possible to the Bo of the transmitted signal. The total power P1 received shall be measured in dBW.
- The resolution bandwidth of the spectrum analyser shall be set as close as possible to the specified measuring bandwidth: 40 kHz. If the resolution bandwidth is different from the specified bandwidth then a bandwidth correction factor shall be performed. The maximum value P2 of the power received in any 40 kHz bandwidth over the Bo shall be measured in dBW.
- The maximum EIRP density per 40 kHz ratio relative to the EIRP, in dBc/40 kHz, is the difference (P1 - P2).

6.3.4.3 Maximum on-axis EIRP

6.3.4.3.1 General

For purpose of the test, the EUT is the AES fitted with its antenna.

The distance between the EUT or the substitution antenna and the measuring antenna shall be such that the radiating near-field of each antenna shall not overlap with that of the other. The larger radiating near-field of the EUT and substitution antenna shall be used to determine the minimum distance between the EUT and measuring antenna in the first instance.

6.3.4.3.2 Test site

This test shall be performed on either an outdoor far-field test site or compact test range. However, if the near-field scanner technology to convert near-field measurements to far-field results is proven and sufficiently accurate by reference to tests taken in both regions then antenna measurements may be taken in the near field.

6.3.4.3.3 Method of measurement

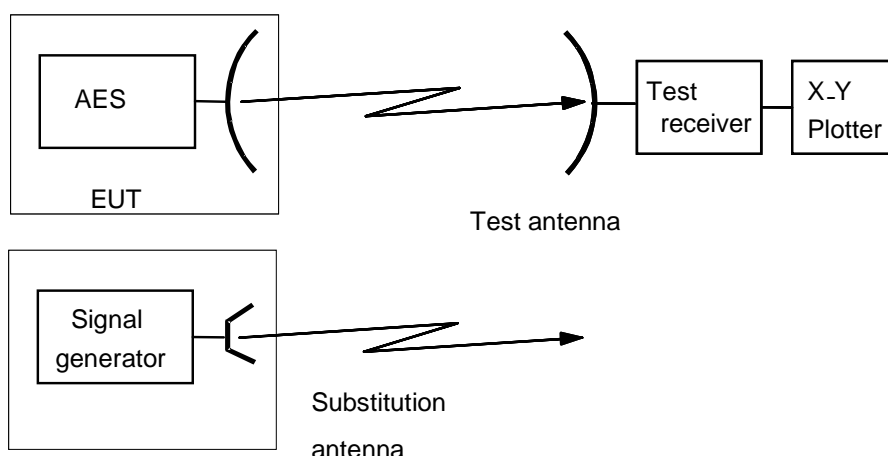

Figure 11: Test arrangement - maximum on-axis EIRP received measurement

- a) The test arrangement shall be as shown in figure 11, both antennas being in line of sight of each other. A signal proportional to the angular position from the servomechanism shall be applied to the X-axis and the signal level from the test receiver proportional to the power received in dBW shall be applied to the Y-axis of the plotter.
- b) The test be carried out with the EUT transmitting the operational waveform signal, at maximum power, which carries a pseudorandom data stream. The transmission shall be continuous where possible.
- c) The resolution bandwidth of the spectrum analyser shall be set larger but as close as possible to the Bo of the transmitted signal.
- d) The ground plane axis shall be pointed horizontal towards the STE. The beam Zn-angle and the beam Az-angle shall be set to 0°.
- e) The initial E-plane of the test signal radiated by the EUT through its antenna shall be horizontal. The test receiver antenna main beam axis shall be aligned with the main beam axis of the EUT antenna. The test receiver antenna or its polarizer shall be rotated around its main beam axis such that its E-plane coincides with the E-plane of the EUT.
- f) After any change of the E-plane of the test signal, the test receiver antenna shall be rotated around its main beam axis such that its E-plane coincides with the E-plane of the EUT.
- g) The frequency of the test signal shall be set 0,5 x Bo above the bottom of the lowest frequency band declared by the manufacturer.
- h) The EUT shall be aligned to maximize the received signal and the X-Y plotter adjusted to give the maximum reading on the chart.
- i) The EUT shall be driven in azimuth in one direction through 10°.
- j) The pattern measurement is then obtained by driving the EUT in azimuth back through boresight to 10° the other side with the plotter recording the results.
- k) The EUT shall be replaced by the signal generator connected to a calibrated antenna (a substitution antenna), transmitting a carrier at a frequency equal to the EUT carrier frequency. The received signal level shall be maximized.
- l) This level shall be recorded on the X-Y plotter.
- m) The signal generator with the substitution antenna shall be driven in azimuth as in h) and j).
- n) The EIRP of the signal radiated by the EUT shall be calculated from:

$$\text{EIRP}_{\text{EUT}} = L_1 - L_2 + G + P$$

where:

- EIRP_{EUT} is the EIRP of the signal radiated by the EUT (dBW), in the considered direction;
 - L₁ is the level obtained with the EUT (dBW), in the considered same direction;
 - L₂ is the level obtained with the signal generator with the substitution antenna (dBW);
 - G is the calibrated gain of the substitution antenna at the test frequency (dBi);
 - P is the power produced by the signal generator at the flange of the substitution antenna (dBW).
- o) The tests in h) to n) shall be repeated with the frequency changed to the middle of the lowest frequency band declared by the manufacturer.
 - p) The tests in h) to n) shall be repeated with the frequency changed to 0,5 x Bo below the top of the lowest frequency band declared by the manufacturer.
 - q) The tests in h) to p) may be performed simultaneously.
 - r) The tests in h) to q) shall be repeated with the E-plane vertical.
 - s) The tests in h) to q) shall be repeated with the E-plane at +45° to the horizontal plane.
 - t) The tests in h) to q) shall be repeated with the E-plane at -45° to the horizontal plane.
 - u) For an active antenna the tests in h) to t) shall be repeated with the beam Zn angle increased in 15° increments up to the maximum beam Zn angle declared by the manufacturer when maximum EIRP variation is expected with the beam Zn angle.
 - v) For an active antenna the tests in h) to u) shall be repeated with the beam Az angle increased in 45° increments when maximum EIRP variation is expected with the beam Az angle.
 - w) The tests in g) to v) shall be repeated for all frequency bands declared by the manufacturer.
 - z) The maximum on-axis EIRP of the signal radiated by the EUT is the maximum value of the values calculated in step n).

6.3.4.4 Antenna transmit radiation patterns

6.3.4.4.1 General

For the purpose of the present document, the antenna transmit radiation patterns are diagrams relating field strength to direction relative to the pointing angle of the antenna at a constant large distance from the antenna.

For purpose of the test, the EUT shall be the AES fitted with its antenna.

The distance between the EUT or the substitution antenna and the measuring antenna shall be such that the radiating near-field of each antenna shall not overlap with that of the other. The larger radiating near-field of the EUT and substitution antenna shall be used to determine the minimum distance between the EUT and measuring antenna in the first instance.

6.3.4.4.2 Test site

This test shall be performed on either an outdoor far-field test site or compact test range. However, if the near-field scanner technology to convert near-field measurements to far-field results is proven and sufficiently accurate by reference to tests taken in both regions then antenna measurements may be taken in the near field.

6.3.4.4.3 Method of measurement

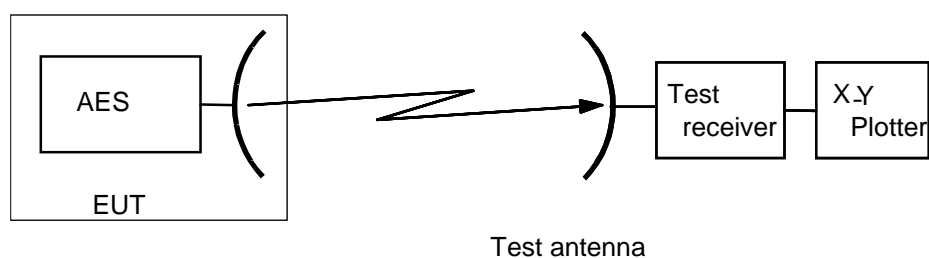

Figure 12: Test arrangement - antenna transmit radiation pattern measurement

- a) The test arrangement shall be as shown in figure 12, both antennas being in line of sight of each other. A signal proportional to the angular position from the servomechanism shall be applied to the X-axis and the signal level from the test receiver proportional to the power received in dBW shall be applied to the Y-axis of the plotter.
- b) The test be carried out with the EUT transmitting the operational waveform signal, which carries a pseudorandom data stream. The transmission shall be continuous where possible.
- c) The resolution bandwidth of the spectrum analyser shall be set larger but as close as possible to the Bo of the transmitted signal.
- d) The antenna main beam axis shall be pointed horizontal towards the STE. The beam Zn-angle and the beam Az-angle shall be set to 0°.
- e) The initial E-plane of the test signal radiated by the EUT through its antenna shall be horizontal. The test receiver antenna main beam axis shall be aligned with the main beam axis of the EUT. The test receiver antenna or its polarizer shall be rotated around its main beam axis such that its E-plane is coincides with the E-plane of the EUT.
- f) After any change of the E-plane of the EUT test signal, the test receiver antenna shall be rotated around its main beam axis such that its E-plane is coincides with the E-plane of the EUT.
- g) The frequency of the EUT test signal shall be set 0,5 x Bo above the bottom of the lowest frequency band declared by the manufacturer.
- h) The EUT shall be aligned to maximize the received signal and the X-Y plotter adjusted to give the maximum reading on the chart.
- i) The EUT shall be driven in azimuth to -180°.
- j) The transmit pattern measurement is then obtained by driving the EUT in azimuth through from -180° to +180° with the plotter recording the results. Measurements may be excluded where the radiation pattern from the antenna is fully blocked by the aircraft fuselage for the models declared by the manufacturer. Exclusions shall be noted in the test report.
- k) The tests in h) to j) shall be repeated with the frequency changed to the middle of the lowest frequency band declared by the manufacturer.
- l) The tests in h) to j) shall be repeated with the frequency changed to 0,5 x Bo below the top of the lowest frequency band declared by the manufacturer.
- m) The tests in h) to l) may be performed simultaneously.
- n) The tests in f) to m) shall be repeated with the E-plane vertical.
- o) The tests in f) to m) shall be repeated with the E-plane at + α to the horizontal plane. α is defined as the worst-case angle (°) between the horizontal plane and the geostationary orbital arc, as seen from the range of latitudes as declared by the manufacturer.
- p) The tests in f) to m) shall be repeated with the E-plane at - α to the horizontal plane. α is as defined in k).

- q) For an active antenna, the tests in f) to p) shall be repeated with beam Zn angle increased in 15° increments up to the maximum beam Zn angle declared by the manufacturer when maximum EIRP variation is expected with beam Zn angle.
- r) For an active antenna, the tests in f) to q) shall be repeated with the beam Az angle increased in 45° increments when maximum EIRP variation is expected with the beam Az angle.
- s) The tests in f) to r) shall be repeated for all frequency bands declared by the manufacturer.

6.3.4.5 Computation of results

The results shall be computed by producing a "mask" to the specified limits with the reference level being equal to the sum of the transmitter on-axis EIRP (measured in clause 6.3.4.2) and the ratio between the maximum EIRP density per 40 kHz ratio to the EIRP (measured in clause 6.3.4.3). The mask shall be a function of ϕ and shall take account of the value $\delta\phi$ equal to the rms of the measured pointing accuracy. This reference shall then be placed on the maximum point of the plot obtained from the transmit radiation pattern measurement, so as to ascertain that the off-axis EIRP density is within the mask, and thus conforming to the specification.

6.4 Power Flux Density Test

6.4.1 General

Tests consist in:

- 1) Verification of specification 1: mode of PFD limitation (see clause 6.4.2).
- 2) Verification of specification 2: Location where to limit the PFD (see clause 6.4.3).
- 3) Verification of specification 3: PFD limitation (see clause 6.4.4):
 - a) Measurement of the radiation pattern below the aircraft fuselage (see clause 6.4.4.1).
 - b) Measurement of on-axis EIRP as a function of altitude (see clause 6.4.4.2).
 - c) Computation of the power flux density at the surface of the Earth (see clause 6.4.4.3).
- 4) Verification of specification 4: Fault conditions (see clause 6.4.5).

The applicant shall provide a STE, with the necessary functionality to perform the required tests. The STE may be a NCF, or an equipment simulating some functions of the NCF, for the purpose of the tests, e.g. the transmission of test messages and the display of the messages received and transmitted.

Within that clause 6.4, the aircraft parameters are the necessary parameters provided by the aircraft and used for the determination of the transmissions parameters.

6.4.2 Verification of specification 1: mode of PFD limitation

The applicant shall declare:

- the modes of limitation which are implemented within the AES, at least one; and
- the AES interfaces involved in the PFD limitation as specified in specification 1 of clause 4.2.6 with their characteristics.

These declared AES interfaces shall be in accordance with the user documentation.

Unless declared by the applicant the above information shall be taken from the user documentation.

6.4.3 Verification of specification 2: Location where to limit the PFD

The applicant shall demonstrate by documentary evidence that with the declared NCF-AES interface and relevant aircraft-AES interfaces the NCF and the AES are able to determine, with the accuracy declared by the applicant, the locations where to limit the PFD as required in specification 2 in clause 4.2.6.

The applicant shall demonstrate:

- that the declared interfaces exist;
- that the declared relevant parameters for the transmission parameter determination are transmitted by the AES towards the NCF or the STE simulating a NCF; and
- that the declared transmission parameters received from the NCF are effectively received from the NCF or from the STE simulating a NCF.

For an AES which determines partially where to limit the PFD, based on its location, the applicant shall demonstrate:

- that the AES is able to determine where to limit the PFD when the values of the declared relevant parameters collected by the AES and the transmission parameters received from the NCF or from the STE are modified.

The test configuration described in clause 6.4.5 for the verification of specification 4 shall apply.

6.4.4 Verification of specification 3: PFD limitation

6.4.4.1 Measurement of the antenna radiation pattern below the aircraft fuselage

6.4.4.1.1 General

In this test the EUT is mounted on a ground plane that is representative of an aircraft fuselage section. The ground plane shall have a diameter equal to the smallest fuselage diameter of the range of aircraft models declared by the manufacturer with which the EUT will operate. If required this test can be repeated with ground planes representative of each aircraft model declared by the manufacturer.

One method for a test of the EUT is given below in clause 6.4.4.1.3. It is the responsibility of the equipment manufacturer to define a detailed test methodology for his AES system.

6.4.4.1.2 Test site

Test sites, far-field or compact range, shall be limited to those that adhere to the standards and definitions provided in IEEE STD 149 [3]. The test site shall be capable of substitution method gain measurements as defined by the above IEEE standard.

6.4.4.1.3 Test method procedure

This test measures the antenna radiation pattern on a cross section perpendicular to the aircraft longitudinal axis, with the AES mounted on the aircraft fuselage.

All range setup and tests shall be undertaken with the EUT transmitting at EIRP_{max}.

The following setup and test pertains to each frequency and polarization to be measured. All EUT measurements are to have the radome in place.

- a) A typical fuselage roll plane test arrangement shall be as shown in figure 13. This figure shows an AES antenna mounted on a metallic fuselage section of an aircraft. The fuselage section is mounted in the compact range such that it can be rotated through 360° to allow the measurement of the radiation pattern below the fuselage section.
- b) Range receiver linearity and peak level shall be set using an appropriate calibrated antenna.
- c) Range receiver dynamic range shall be greater than 120 dB with linearity demonstrated 30 dB above the peak standard level.

- d) A reference level gain pattern shall be recorded through the beam peak.
- e) The calibrated antenna shall be removed from the test set-up and replaced with the fuselage section, EUT, and radome. No change to the range configuration other than the replacement of the calibrated antenna with the fuselage section, EUT, and radome is permitted.
- f) Set the antenna Zn-angle and the beam Zn-angle of the EUT to the maximum specified angle, θ_{\min} as declared by the manufacturer.
- g) Record the complete 360° EUT roll plane radiation pattern.
- h) Adjust/normalize the received EUT radiation pattern level based on the difference between the measured reference gain standard level and the certified reference gain level.

Repeat a) through h) at each desired frequency and emitted polarization.

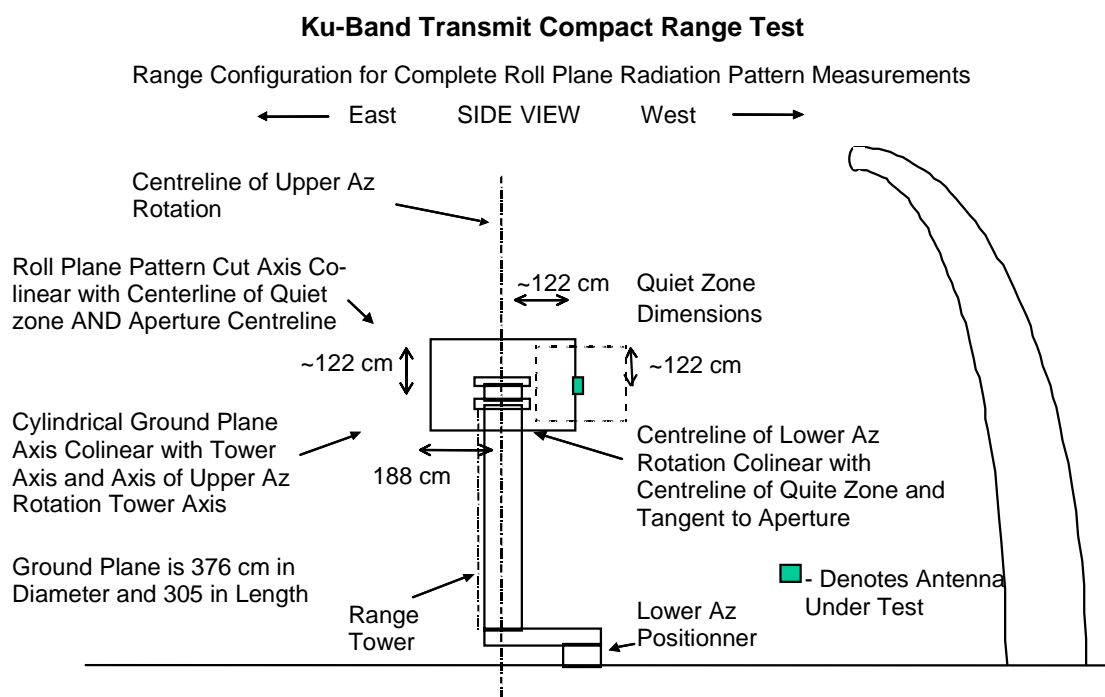

Figure 13: An example of a test set-up for measuring the roll plane radiation pattern beneath the fuselage of an aircraft

6.4.4.2 Measurement of on-axis EIRP as a function of altitude

6.4.4.2.1 General

In this test the STE is used to simulate the operation of the AES within line-of-sight of an operating FS (ITU Radio Regulations footnotes 5.508a, 5.509a, 5.505, and 5.508) and/or a radio astronomy site (14,47 GHz to 14,50 GHz). The test will measure EIRP as a function of altitude. In cases where the NCF issues PFD limitation commands, STE will also be used to simulate the NCF.

If the EUT is an AES that has been modified by the manufacturer for these tests then full documentation of such modification(s) shall be provided to prove that the modification(s) will simulate the required test condition.

6.4.4.2.2 Test site

There are no requirements for the test site to be used for this test.

6.4.4.2.3 Method of measurement with a test antenna

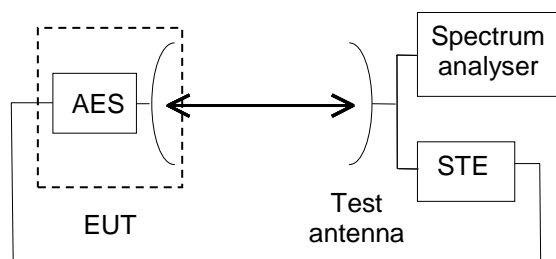

Figure 14: Test arrangement for measurement of on-axis EIRP as a function of altitude

- a) The test arrangement shall be as shown in figure 14.
- b) The resolution bandwidth of the spectrum analyser shall be set larger but as close as possible to the Bo of the transmitted signal.
- c) The STE shall be set to simulate AES operation at 1 km in altitude, or at the minimum declared operational altitude, within line-of-sight of an operating FS, or a radio astronomy site.
- d) The EUT shall transmit one modulated carrier continuously at the minimal Bo declared by the applicant, or at its maximum burst rate where applicable. The transmit signal centre frequency shall be as close to the minimum operational frequency as declared by the applicant for compliance with the FS limitation in the band between 14,25 GHz and 14,50 GHz.
- e) The measuring antenna shall be positioned at a distance from the EUT (e.g. 3 m, 5 m, 10 m) relevant to the applied test site and shall be aligned with the EUT antenna for the transmit frequency.
- f) The tests in d) to e) shall be repeated with a transmit frequency in the centre of the operating frequency band.
- g) The tests in d) to e) shall be repeated with a transmit frequency as close to the upper limit of the operating frequency band of the EUT as possible.
- h) The tests in d) to g) shall be repeated with the simulated altitude successively set to 2 km, 4 km, 8 km, 12 km, if applicable.
- i) The tests in b) to h) shall be repeated with the nominated bandwidth set to the maximum Bo as declared by the applicant.
- j) The tests in sections b) to i) shall be repeated with the transmit signal centre frequency centred, and as close to the upper limit of the band of operations as declared by the operator for operation with FS in the band between 14,25 GHz and 14,50 GHz.
- k) The tests in sections b) to i) shall be repeated with the transmit signal as close to the minimum operational frequency, centred at the centre frequency, and as close to the maximum operational frequency of the band of operations as declared by the operator for operation with RA in the band between 14,47 GHz and 14,50 GHz.
- l) The above test shall be repeated for protection of FS band between 14,00 GHz and 14,25 GHz. These tests can be replaced by documentary evidence, based on the results provide for protection of the FS band between 14,25 GHz and 14,50 GHz.

6.4.4.3 Computation of the power flux density at the surface of the Earth

The PFD at the surface of the Earth shall be calculated as follows:

- 1) The EIRP pattern below the aircraft shall be computed for each transmit frequency and altitude tested in clause 6.4.2. This is done using the maximum on-axis EIRP spectral density measured in:
 - a) the 14,25 GHz to 14,50 GHz band with respect to FS requirements; and
 - b) the 14,47 GHz to 14,50 GHz band with respect to Radio Astronomy requirements;
 using the gain pattern below the aircraft measured in clause 6.4.1.

- 2) Then for each transmit frequency and altitude tested in clause 6.4.2, the PFD at the surface of the earth as a function of arrival angle shall be computed using the EIRP pattern below the aircraft (calculated above) for that test condition and the method of computing the PFD at the surface of the Earth described in annex D of ITU-R Recommendation M.1643 [5].

These computations shall take into account the inaccuracy on the locations where the PFD has to be limited.

NOTE: This inaccuracy is a function of the period of transmission of the location of the aircraft, of the maximum speed of the aircraft, of its maximum trajectory deviations, of the inaccuracy of the position measurements, on the time distribution within the network, of the transmissions delays, of the delays within successive buffers.

- 3) Finally, for each frequency and altitude tested, the resulting PFD at the surface of the earth as a function of arrival angle can be compared to the limits in clauses 4.2.6.2 and 4.2.6.3 to verify compliance.

6.4.5 Verification of specification 4: Fault conditions

6.4.5.1 Test Arrangement

The tests in this clause shall be performed either using the test setup as illustrated in figure 14, or with the AES installed on an airplane and a test NCF.

6.4.5.2 Test method

- 1) Uncompleted collection of the aircraft parameters:
 - a) The EUT shall be in the "Transmission enabled" state and shall be transmitting data.
 - b) The EUT shall require aircraft parameters through its command interface with the aircraft.
 - c) A fault condition on the collection of the transmission parameters shall be generated.
 - d) The EUT shall enter the "Transmission disabled" state within the time frame declared by the applicant.

The events from a) to d) shall be displayed and verified with the oscilloscope and by measurement of the transmitted signal.

- 2) Uncompleted transmission of the aircraft state parameters by the EUT to the NCF:
 - a) The EUT shall be in the "Transmission enabled" state.
 - b) The EUT shall send a status message with the new aircraft state parameter(s) to the NCF or STE. Either this is done periodically or when the aircraft state parameter(s) change. In that second case the aircraft state parameter(s) shall be modified so that the EUT send a status message.
 - c) The EUT shall transmit status message with the aircraft state parameters, as declared by the applicant, to the NCF or STE.
 - d) The transmission of the status message by the EUT to the NCF or STE shall be interrupted.
 - e) The EUT shall enter the "Transmission disabled" state within the time frame declared by the applicant.

The events from a) to e) shall be displayed and verified with the oscilloscope or recorded command time.

If this test can not be performed as specified above, this demonstration may be replaced by documentary evidences.

- 3) Transmission parameter not received or not correctly received from the NCF:
 - a) The EUT shall be in the "Transmission enabled" state.
 - b) The reception of transmission parameters messages from the NCF or STE shall be inhibited.
 - c) The EUT shall send a status message with the new aircraft state parameter(s) to the NCF or STE. Either this is done periodically or when the aircraft state parameter(s) change. In that second case the aircraft state parameter(s) shall be modified so that the EUT send a status message.

- d) The EUT shall transmit the status message with the aircraft state parameters to the NCF or STE.
- e) Without receiving from the NCF or STE the message with the transmission parameters within the time frame declared by the applicant the EUT shall enter the "Transmission disabled" state.

The events from a) to e) shall be displayed and verified with the oscilloscope and by measurement of the transmitted signal.

If this test can not be performed as specified above, this demonstration may be replaced by documentary evidences.

6.5 Control and monitoring

If the EUT is an AES that has been modified by the manufacturer for these tests then full documentation of such modification(s) shall be provided to prove that the modification(s) will simulate the required test condition.

For the purpose of this test the EUT is defined as the AES either with or without its antenna connected.

The measurement of the EIRP spectral density shall be limited to within either the nominated bandwidth or a 10 MHz bandwidth centred on the carrier frequency, whichever is the greater.

6.5.1 Test arrangement

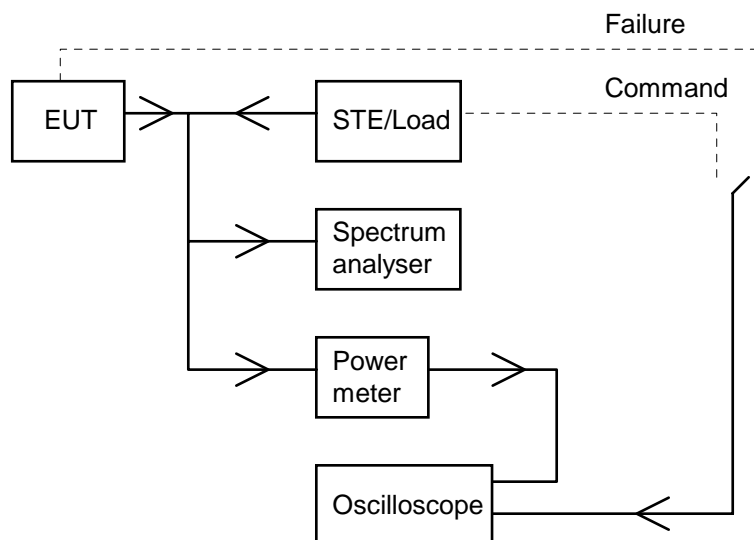

Figure 15: General test arrangement for control and monitoring tests for conducted measurements

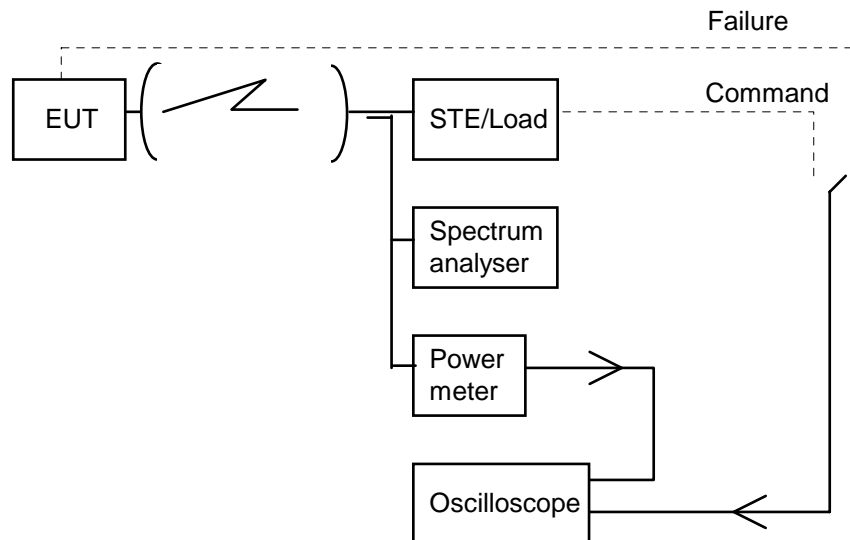

Figure 16: General test arrangement for control and monitoring tests for radiated measurements

The test arrangement shall be as shown in figures 15 or 16. The EUT shall be authorized to transmit and shall be in the carrier-on state at the commencement of each test. The dual trace storage oscilloscope shall monitor by measuring the time difference between the command, or failure, and the occurrence of the expected event (e.g. the transmission suppression). Alternatively, command messages may be automatically recoded and time stamped for comparison to the occurrence of the expected event. The power meter and spectrum analyser shall monitor the EUT output level.

6.5.2 Processor monitoring

6.5.2.1 Test method

- a) Each of the processors within the EUT shall, in turn, be caused to fail.
- b) Within 1 s of such failure the EUT shall cease to transmit as measured by the oscilloscope.
- c) The power meter and spectrum analyser shall be observed to ascertain that the transmissions have been suppressed.
- d) The failed processor shall be restored to normal working condition and the EUT shall be restored to normal working before the next processor shall be induced to fail.

6.5.3 Transmit subsystem monitoring

6.5.3.1 Test method

- a) The frequency generation subsystem shall be caused to fail in respect of:
 - 1) frequency stability;
 - 2) output.
- b) Within 6 s of such failure the EUT shall cease to transmit as measured by the oscilloscope.
- c) The power meter and spectrum analyser shall be observed to ascertain that the transmissions have been suppressed.
- d) The frequency generation subsystem shall be restored to normal working condition and the EUT shall be restored to normal working before the next induced failure.

6.5.4 Power-on/Reset

6.5.4.1 Test method

- a) The EUT shall be switched off and the STE shall not transmit the CC.
- b) The EUT shall be switched on.
- c) The EUT shall not transmit during and after switching-on, and shall enter the Transmission disabled state.

The events from a) to c) shall be displayed and verified with the oscilloscope and by measurement of the transmitted signal. If a manual reset function is implemented the following test shall be performed:

- d) The EUT shall be switched on and the STE shall transmit the CC.
- e) A call shall be initiated from the EUT and the EUT shall enter the carrier-on state.
- f) The reset function shall be initiated.
- g) The EUT shall enter the Transmission disabled state.

The event from e) to g) shall be displayed and verified with the oscilloscope or recorded command time and by measurement of the transmitted signal.

6.5.5 Control Channel (CC) reception

6.5.5.1 Test method

The following tests shall be performed:

- case where the CC has never been received by the EUT;
- case where the CC is lost by the EUT during a transmission period of a call;
- case where the CC is lost by the EUT during a period without transmission;
- case where the CC is being lost by the EUT and a call is initiated within the Time-Out period T1;
- case where the CC requests a change of transmission parameters to the EUT.

The Time-Out period T1 used in the tests shall be 30 s.

- a) Case where the CC has never been received by the EUT:
 - a1) The EUT shall be switched off and the STE shall not transmit the CC.
 - a2) The EUT shall be switched on.
 - a3) A call shall be initiated from the EUT.
 - a4) The EUT shall remain in the Transmission disabled state.

The events from a2) to a4) shall be displayed and verified with the oscilloscope or recorded command time and by measurement of the transmit signal.

- b) Case where the CC is lost by the EUT during a transmission period of a call:
 - b1) The EUT shall be switched-on and the STE shall transmit the CC.
 - b2) A call shall be initiated from the EUT.
 - b3) The STE shall stop transmitting the CC.
 - b4) Within T1 from b3), the EUT shall enter the Transmission disabled state.

The events from b2) to b4) shall be displayed and verified with the oscilloscope or recorded command time and by measurement of the transmitted signal.

- c) Case where the CC is lost by the EUT during a period without transmission:
 - c1) The EUT shall be switched on and the STE shall transmit the CC.
 - c2) The STE shall stop transmitting the CC.
 - c3) More than T1 later, a call shall be initiated from the EUT.
 - c4) The EUT shall remain in the Transmission disabled state.

The events from c2) to c4) shall be displayed and verified with the oscilloscope or recorded command time and by measurement of the transmitted signal.

- d) Case where the CC is being lost by the EUT and a call is initiated within the T1 period:
 - d1) The EUT shall be switched on and the STE shall transmit the CC.
 - d2) The STE shall stop transmitting the CC.
 - d3) Within the period T1 from d2), a call shall be initiated from the EUT.
 - d4) The EUT may transmit but within the T1 period the EUT shall enter the Transmission disabled state.

The events from d2) to d4) shall be displayed and verified with the oscilloscope or recorded command time and by measurement of the transmitted signal.

- e) Case where the CC requests a change of transmission parameters to the EUT:
 - e1) The EUT shall be on the Transmission enabled state.
 - e2) The STE shall transmit to the EUT a CC message, requesting a change to, e.g. the EIRP, the data rate or the carrier frequency.
 - e3) After the reception by the EUT of the CC message the EUT shall implement the parameters specified in the CC message, within the delay declared by the applicant for compliance with the present document.

The events from e1) to e3) shall be displayed and verified with the oscilloscope or recorded command time and by measurement of the transmitted signal.

6.5.6 Network control commands

6.5.6.1 Test method

The following tests shall be performed in sequence:

- Transmission enable command.
- Transmission disable command.
- Identification request.
- a) Transmission enable command:
 - a1) The EUT shall be switched-on and the STE shall transmit the CC.
 - a2) The EUT shall enter the initial phasestate.
 - a3) A call (or data transmission) shall be initiated from the EUT, the EUT shall remain in the Transmission disabled state.
 - a4) The STE shall transmit an enable command addressed to the EUT.
 - a5) A call shall be initiated from the EUT.

- a6) The EUT shall enter the carrier-on state and shall transmit at the transmission parameters specified in the CC received from the STE.

The events from a2) to a6) shall be displayed and verified with the oscilloscope or recorded command time and by measurement of the transmitted signal.

- b) Transmission disable command:
 - b1) Continue from a6).
 - b2) The STE shall transmit a disable command to the EUT.
 - b3) The EUT shall enter the Transmission disabled state within 1 s.
 - b4) A call shall be initiated from the EUT.
 - b5) The EUT shall remain in the Transmission disabled state.
 - b6) The STE shall transmit an enable command.
 - b7) A call shall be initiated from the EUT.
 - b8) The EUT shall enter the carrier-on state and shall transmit.

The events from b2) to b8) shall be displayed and verified with the oscilloscope or recorded command time and by measurement of the transmitted signal.

- c) Identification request:
 - c1) Continue from b8).
 - c2) The STE shall transmit an identification request.
 - c3) The EUT shall transmit its identification code.

The STE shall display the identification code sent by the EUT.

6.5.7 Initial burst transmission

6.5.7.1 Test method

This test procedure applies only to AESs which are designed to transmit initial bursts.

- a) The EUT is switched-off and the STE shall be transmitting the CC.
- b) The EUT shall be switched-on and shall enter the initial state.
- c) The EUT shall not transmit, except the initial bursts, if any.
- d) Each initial burst shall not last more than 1 s, and the transmission of the initial bursts shall not exceed 1 % of the time.

The events from b) to d) shall be displayed and verified with the oscilloscope or recorded command time and by measurement of the transmitted signal.

Annex A (normative): The EN Requirements Table (EN-RT)

Notwithstanding the provisions of the copyright clause related to the text of the present document, ETSI grants that users of the present document may freely reproduce the EN-RT proforma in this annex so that it can be used for its intended purposes and may further publish the completed EN-RT.

The EN Requirements Table (EN-RT) serves a number of purposes, as follows:

- it provides a tabular summary of all the requirements;
- it shows the status of each EN-Requirement, whether it is essential to implement in all circumstances (Mandatory), or whether the requirement is dependent on the manufacturer having chosen to support a particular optional service or functionality (Optional). In particular it enables the EN-Requirements associated with a particular optional service or functionality to be grouped and identified;
- when completed in respect of a particular equipment it provides a means to undertake the assessment of conformity with the EN.

The EN-RT is placed in an annex of the EN in order that it may be photocopied and used as a proforma.

Table A.1: EN Requirements Table (EN-RT)

EN Reference		EN			Comment
No.	Reference	EN-Requirements (see note)	Status		
1	4.2.2	Spurious radiation	M		
2	4.2.3	On-axis spurious radiation	M		
3	4.2.4	Off-axis EIRP density in the Nominated bandwidth	M		
4	4.2.5.1	Processor monitoring	M		
5	4.2.5.2	Transmit subsystem monitoring	M		
6	4.2.5.3	Power-on/Reset	M		
7	4.2.5.4	Control Channel (CC) reception	M		
8	4.2.5.5	Network control commands	M		
9	4.2.5.6	Initial burst transmission	M		
10	4.2.6.2	Power flux density limits in the 14,00 GHz to 14,50 GHz frequency band	M		

NOTE: These EN-Requirements are justified under article 3.2 of the R&TTE Directive.

Key to columns:

- No.** Table entry number;
- Reference** Clause reference number of conformance requirement within the present document;
- Status** Status of the entry as follows:
- M Mandatory, shall be implemented under all circumstances;
 - O Optional, may be provided, but if provided shall be implemented in accordance with the requirements;
 - O.n This status is used for mutually exclusive or selectable options among a set. The integer "n" shall refer to a unique group of options within the EN-RT. A footnote to the EN-RT shall explicitly state what the requirement is for each numbered group. For example, "It is mandatory to support at least one of these options", or, "It is mandatory to support exactly one of these options".
- Comments** To be completed as required.

Annex B (normative): Environmental conditions

B.1 General

This annex specifies the environmental conditions under which the relevant requirements of the present document shall be fulfilled.

Testing under other environmental conditions will be undertaken by manufacturers according to the requirements of EUROCAE ED-14D/RTCA DO-160D [4], and need not be repeated as it is not a requirement of the present document.

NOTE: DO-160D "Environmental Conditions and Test Procedures for Airborne Equipment", Issued 7-29-97, superseded DO-160C, Changes 1, 2 and 3, Prepared by SC-135. Standard procedures and environmental test criteria for testing airborne equipment for the entire spectrum of aircraft from light general aviation aircraft and helicopters through the "Jumbo Jets" and SST categories of aircraft. The document includes 25 sections and three appendices. Examples of tests covered include vibration, power input, radio frequency susceptibility, lightning, and electrostatic discharge. Coordinated with EUROCAE, RTCA DO-160D and EUROCAE ED-14D [4] are identically worded. DO-160C is recognized by the International Organization for Standardization (ISO) as de facto international standard ISO 7137.

B.2 Environmental conformance requirements

Aircraft Earth Stations are Installable Equipments (IE) typically consisting of:

- a) an Internally Mounted Equipment (IME) may consist of the following three units:
 - i) a Satellite Terminal Unit (STU);
 - ii) a High Power Amplifier (HPA);
 - iii) a Low Noise Amplifier/Diplexer (LNA/D);
- b) an Externally Mounted Equipment (EME), consisting of an antenna assembly which can be either:
 - i) a single reflector antenna; or
 - ii) two active phased array antennas (one receive and one transmit).

B.3 Environmental test conditions

The equipments comprising the AES may be subject to different environmental hazards and are required to maintain their performance in accordance with the present document under all environmental circumstances for the Equipment Categories applicable to them as defined in EUROCAE ED-14D. Whilst the AES being subjected to the EUROCAE ED-14D [4] environmental conditions and specifications, tests specified in the present document shall be maintained within the following envelope of environmental conditions (or otherwise as specified by the manufacturer):

- a) for the IME (ambient conditions):
 - temperature: +15°C to +35°C;
 - relative humidity: ≤ 85 %;
 - pressure: 840 hPa to 1 070 hPa (equivalent to +1 525 m to -460 m altitude).

Tests made at environmental conditions other than ambient as specified above shall be conducted subject to the following tolerances:

- Temperature: $\pm 3^{\circ}\text{C}$;
- Pressure: $\pm 5\%$.

b) for the EME:

- temperature: -55°C to $+35^{\circ}\text{C}$;
- relative humidity: $\leq 85\%$;
- pressure: 91 hPa to 1 070 hPa (equivalent to +16 800 m to -460 m altitude).

The power supply shall be in accordance with EUROCAE ED-14D/RTCA DO-160D [4] Normal Operating Conditions (nominal), for the Equipment Category applicable to the AES.

Annex C (informative): Bibliography

ECC Report 26: "The compatibility & sharing of the aeronautical mobile satellite service with existing services in the band 14,00 to 14,50 GHZ Molde", February 2003.

Directive 98/34/EC of the European Parliament and of the Council of 22 June 1998 laying down a procedure for the provision of information in the field of technical standards and regulations.

ETSI EN 301 489 (all parts): "Electromagnetic compatibility and Radio spectrum Matters (ERM); ElectroMagnetic Compatibility (EMC) standard for radio equipment and services".

Council Directive 89/336/EEC of 3 May 1989 on the approximation of the laws of the Member States relating to electromagnetic compatibility (EMC Directive).

Council Directive 73/23/EEC of 19 February 1973 on the harmonization of the laws of Member States relating to electrical equipment designed for use within certain voltage limits (LV Directive).

ETSI EN 301 427 (V1.2.1): "Satellite Earth Stations and Systems (SES); Harmonized EN for Low data rate Mobile satellite Earth Stations (MESs) except aeronautical mobile satellite earth stations, operating in the 11/12/14 GHz frequency bands covering essential requirements under article 3.2 of the R&TTE directive".

ETSI EN 301 428 (V1.2.1): "Satellite Earth Stations and Systems (SES); Harmonized EN for Very Small Aperture Terminal (VSAT); Transmit-only, transmit/receive or receive-only satellite earth stations operating in the 11/12/14 GHz frequency bands covering essential requirements under article 3.2 of the R&TTE directive".

ITU-R Recommendation S.524-7: "Maximum permissible levels of off-axis e.i.r.p. density from earth stations in geostationary-satellite orbit networks operating in the fixed-satellite service transmitting in the 6 GHz, 14 GHz and 30 GHz frequency bands".

ITU Radio Regulations.

ISO 7137 (1995): "Aircraft - Environmental conditions and test procedures for airborne equipment".

History

Document history			
V1.1.1	April 2003	Public Enquiry	PE 20030815: 2003-04-16 to 2003-08-15
V1.1.1	November 2003	Vote	V 20040123: 2003-11-24 to 2004-01-23
V1.1.1	January 2004	Publication	