



EUROPEAN STANDARD

**Environmental Engineering (EE);  
Powering of equipment in access network**

---

Reference

REN/EE-0257

---

Keywords

access, network, power supply, remote

**ETSI**

650 Route des Lucioles  
F-06921 Sophia Antipolis Cedex - FRANCE

Tel.: +33 4 92 94 42 00 Fax: +33 4 93 65 47 16

Siret N° 348 623 562 00017 - NAF 742 C  
Association à but non lucratif enregistrée à la  
Sous-Préfecture de Grasse (06) N° 7803/88

---

**Important notice**

The present document can be downloaded from:

<http://www.etsi.org/standards-search>

The present document may be made available in electronic versions and/or in print. The content of any electronic and/or print versions of the present document shall not be modified without the prior written authorization of ETSI. In case of any existing or perceived difference in contents between such versions and/or in print, the prevailing version of an ETSI deliverable is the one made publicly available in PDF format at [www.etsi.org/deliver](http://www.etsi.org/deliver).

Users of the present document should be aware that the document may be subject to revision or change of status.

Information on the current status of this and other ETSI documents is available at

<https://portal.etsi.org/TB/ETSIDeliverableStatus.aspx>

If you find errors in the present document, please send your comment to one of the following services:

<https://portal.etsi.org/People/CommiteeSupportStaff.aspx>

---

**Copyright Notification**

No part may be reproduced or utilized in any form or by any means, electronic or mechanical, including photocopying and microfilm except as authorized by written permission of ETSI.

The content of the PDF version shall not be modified without the written authorization of ETSI.

The copyright and the foregoing restriction extend to reproduction in all media.

© ETSI 2020.

All rights reserved.

**DECT™**, **PLUGTESTS™**, **UMTS™** and the ETSI logo are trademarks of ETSI registered for the benefit of its Members.

**3GPP™** and **LTE™** are trademarks of ETSI registered for the benefit of its Members and of the 3GPP Organizational Partners.

**oneM2M™** logo is a trademark of ETSI registered for the benefit of its Members and of the oneM2M Partners.

**GSM®** and the GSM logo are trademarks registered and owned by the GSM Association.

# Contents

Intellectual Property Rights .....	5
Foreword.....	5
Modal verbs terminology.....	5
1 Scope .....	6
2 References .....	6
2.1 Normative references .....	6
2.2 Informative references.....	8
3 Definition of terms, symbols and abbreviations.....	9
3.1 Terms.....	9
3.2 Symbols.....	10
3.3 Abbreviations .....	11
4 Powering configurations.....	12
4.0 General .....	12
4.1 Remote powering architectures .....	14
4.1.1 Centralized powering architecture configurations .....	14
4.1.2 Cluster powering architecture configurations .....	15
4.2 Local powering architecture configurations .....	17
4.2.1 TE of access network, common to several customers.....	17
4.2.2 TE of access network, at customer premises .....	18
4.2.3 TE in access network reverse powered from customer premises.....	19
4.2.3.1 Reference configuration introduction.....	19
4.2.3.2 Wiring and electrical limitation consideration .....	19
4.2.3.3 Reverse power, voltage and current limits .....	19
5 Effect of the technologies on the powering strategy .....	19
5.0 General .....	19
5.1 Powering strategy of family 1: metallic links.....	21
5.2 Powering strategy of family 2: non-metallic links .....	21
6 Requirements for local powering .....	21
6.1 TE including the power plant.....	21
6.2 TE powered by a DC voltage nominal -48 V or up to 400 VDC local power unit.....	22
6.3 TE powered by a LPU with a DC voltage other than -48 V or up to 400 VDC .....	22
6.4 TE powered by a nominal AC voltage of 230 V, 50 Hz local power unit.....	22
7 Requirements for remote powering .....	22
7.0 Remote powering solutions .....	22
7.1 Input of the Remote Power Unit (RPU) .....	22
7.2 Output characteristics of the Remote Powering system .....	23
7.2.1 Remote powering output with a RFT-V circuit .....	23
7.2.2 Remote powering output with a RFT-C circuit.....	23
7.2.3 Remote powering output at up to 400 VDC .....	23
7.2.3.0 General consideration on line electrical parameters and operation .....	23
7.2.3.1 Steady state output voltage and current.....	23
7.2.3.2 Transient state output voltage .....	23
7.2.3.3 Architecture of RP distribution for reliable and safe operation management .....	24
7.2.3.4 Requirements for stable and safe operation .....	25
7.3 Input characteristics of remote power receiver.....	25
7.3.1 RFT-V remote power receiver input in voltage mode .....	25
7.3.2 RFT-C remote power receiver input in current mode .....	25
7.3.3 Remote Power Receiver (RPR) input .....	26
7.3.4 Remote Power Receiver (RPR) output .....	26
8 Power source interruption management .....	26
9 Power management .....	27

10	Safety, EMC, protection.....	29
10.1	Product Safety .....	29
10.2	EMC .....	30
10.3	Protection/resistibility .....	30
10.4	Earthing and bonding of access network powering solutions.....	30
10.5	Wiring requirements of remote power feeding to TE through power cable at up to 400 VDC voltage mode.....	31
10.5.1	Protection against electric shock.....	31
10.5.2	Protection against fire .....	32
10.5.3	Protection against physical damage .....	32
11	Environmental conditions.....	32
<b>Annex A (informative):</b>	<b>Statistical data on electrical power supply availability, from the Low Voltage (LV) public grid (mains) in various European countries .....</b>	<b>33</b>
<b>Annex B (informative):</b>	<b>Battery sizing.....</b>	<b>37</b>
B.0	General rules .....	37
B.1	back-up power .....	38
B.2	Autonomy of the back-up.....	38
B.3	Use of valve regulated lead acid battery.....	39
B.4	Battery state of health test .....	39
<b>Annex C (informative):</b>	<b>Comparative reliability approach of remote powering versus local powering .....</b>	<b>40</b>
<b>Annex D (informative):</b>	<b>Bibliography.....</b>	<b>43</b>
History .....		44

---

## Intellectual Property Rights

### Essential patents

IPRs essential or potentially essential to normative deliverables may have been declared to ETSI. The information pertaining to these essential IPRs, if any, is publicly available for **ETSI members and non-members**, and can be found in ETSI SR 000 314: "*Intellectual Property Rights (IPRs); Essential, or potentially Essential, IPRs notified to ETSI in respect of ETSI standards*", which is available from the ETSI Secretariat. Latest updates are available on the ETSI Web server (<https://ipr.etsi.org/>).

Pursuant to the ETSI IPR Policy, no investigation, including IPR searches, has been carried out by ETSI. No guarantee can be given as to the existence of other IPRs not referenced in ETSI SR 000 314 (or the updates on the ETSI Web server) which are, or may be, or may become, essential to the present document.

### Trademarks

The present document may include trademarks and/or tradenames which are asserted and/or registered by their owners. ETSI claims no ownership of these except for any which are indicated as being the property of ETSI, and conveys no right to use or reproduce any trademark and/or tradename. Mention of those trademarks in the present document does not constitute an endorsement by ETSI of products, services or organizations associated with those trademarks.

---

## Foreword

This draft European Standard (EN) has been produced by ETSI Technical Committee Environmental Engineering (EE), and is now submitted for the combined Public Enquiry and Vote phase of the ETSI standards EN Approval Procedure.

<b>Proposed national transposition dates</b>	
Date of latest announcement of this EN (doa):	3 months after ETSI publication
Date of latest publication of new National Standard or endorsement of this EN (dop/e):	6 months after doa
Date of withdrawal of any conflicting National Standard (dow):	6 months after doa

---

## Modal verbs terminology

In the present document "**shall**", "**shall not**", "**should**", "**should not**", "**may**", "**need not**", "**will**", "**will not**", "**can**" and "**cannot**" are to be interpreted as described in clause 3.2 of the [ETSI Drafting Rules](#) (Verbal forms for the expression of provisions).

"**must**" and "**must not**" are **NOT** allowed in ETSI deliverables except when used in direct citation.

---

# 1 Scope

The present document describes the principles for powering of Telecommunications Equipment (TE) in access networks (both traditional copper based and Next Generation fibre and/or hybrid based) and contains requirements for the powering systems, laying down:

- the characteristics of the input and output interfaces of the power units; the recommendations for TE power protection, also regarding network integrity and public services availability requirements;
- the management data, necessary to guarantee the required availability of the network and provided public services and to ensure the maintenance of the TE power units.

The present document takes into account the innovative characteristics of fibre-based access network equipment, for which the intrinsic limitation of the local power plants should be considered regarding the equipment installed inside telecom centre or local exchanges or installed in streets or inside buildings: it goes from "complete integration of the power plant in the TE" to "remote power feeding from a distant power plant".

The present document provides detailed information in annex A on the improved reliability of public electric power grid and on the improved reliability and availability of new fibre-based NGA network. It should be considered that, for street cabinet TE, the local power scenario is common and, in that case, the main power supply availability characteristics are mainly based on electrical energy provider's performance.

The present document applies to the powering of all equipment of the access network (copper, fibre or radio networks) located inside or outside telecommunications centres or local exchanges, differentiating the applicable and sustainable power protection requirements. The access network is defined as the part of the telecommunications network, which comprises the network termination (passive or active) that is installed inside customer premises and the first exchange that can be also the broadband local exchange.

As innovative fibre-based and hybrid-based NGA network TE are changing the traditional powering paradigm, the present document proposes the viable measures to comply with the integrity, availability and uninterrupted telephone/VoIP provision that European regulatory defines for public networks [i.18].

The present document describes different configurations of powering the TE and the impacts on networks and services continuity and reliability:

- Local power supply for TE (e.g. street cabinet, active network termination, etc.).
- Remote Feeding to TE from central office through copper access pair.
- Cluster Power supply feeding power for a cluster of TE.
- Remote power feeding to TE from centre or cluster power through a power cable.
- Back feeding or Reverse Powering architecture that can supply power to Access Network Units such as ONU or ONT or remote DSL unit from the customer premises through its final distribution access copper pair.

---

## 2 References

### 2.1 Normative references

References are either specific (identified by date of publication and/or edition number or version number) or non-specific. For specific references, only the cited version applies. For non-specific references, the latest version of the referenced document (including any amendments) applies.

Referenced documents which are not found to be publicly available in the expected location might be found at <https://docbox.etsi.org/Reference/>.

NOTE: While any hyperlinks included in this clause were valid at the time of publication, ETSI cannot guarantee their long term validity.

The following referenced documents are necessary for the application of the present document.

- [1] ETSI EN 300 132-1: "Environmental Engineering (EE); Power supply interface at the input to Information and Communication Technology (ICT) equipment; Part 1: Alternating Current (AC)".
  - [2] ETSI EN 300 132-2: "Environmental Engineering (EE); Power supply interface at the input of Information and Communication Technology (ICT) equipment; Part 2: -48 V Direct Current (DC)".
  - [3] IEC 62368-3: "Audio/video, information and communication technology equipment - Part 3: Safety aspects for DC power transfer through communication cables and ports".
  - [4] EN 60038: "CENELEC standard Voltages", (produced by CENELEC).
  - [5] EN 60664-1: "Insulation coordination for equipment within low-voltage systems - Part 1: Principles, requirements and tests", (produced by CENELEC).
  - [6] EN 50310: "Application of equipotential bonding and earthing in buildings with information technology equipment", (produced by CENELEC).
  - [7] ETSI EN 300 253: "Environmental Engineering (EE); Earthing and bonding of ICT equipment powered by -48 VDC in telecom and data centres".
  - [8] Recommendation ITU-T K.35: "Bonding configurations and earthing at remote electronic sites".
  - [9] Recommendation ITU-T K.45: "Resistibility of telecommunication equipment installed in the access and trunk networks to overvoltages and overcurrents".
  - [10] ETSI ES 203 215: "Environmental Engineering (EE); Measurement Methods and Limits for Power Consumption in Broadband Telecommunication Networks Equipment".
  - [11] ETSI EN 300 132-3: "Environmental Engineering (EE); Power supply interface at the input to telecommunications equipment; Part 3: Operated by rectified current source, alternating current source or direct current source up to 400 V".
- NOTE: A revision is on-going in ETSI and this document should become ETSI EN 300 132-3-1: "Direct current source up to 400 V".
- [12] ETSI ES 202 336-1: "Environmental Engineering (EE); Monitoring and Control Interface for Infrastructure Equipment (Power, Cooling and Building Environment Systems used in Telecommunication Networks); Part 1: Generic Interface".
  - [13] ETSI TS 101 548-1: "Access, Terminals, Transmission and Multiplexing (ATTM); European Requirements for Reverse Powering of Remote Access Equipment; Part 1: Twisted pair networks".
  - [14] ETSI EN 301 605: "Environmental Engineering (EE); Earthing and bonding of 400 VDC data and telecom (ICT) equipment".
  - [15] Recommendation ITU-T L.1200 (May 2012): "Direct current power feeding interface up to 400 V at the input to telecommunication and ICT equipment".
  - [16] HD 60364 series: "Low Voltage electrical installations material", produced by CENELEC.
  - [17] ETSI ES 202 336-8: "Environmental Engineering (EE); Monitoring and Control Interface for Infrastructure Equipment (Power, Cooling and Building Environment Systems used in Telecommunication Networks); Part 8: Remote Power Feeding System control and monitoring information model".

## 2.2 Informative references

References are either specific (identified by date of publication and/or edition number or version number) or non-specific. For specific references, only the cited version applies. For non-specific references, the latest version of the referenced document (including any amendments) applies.

NOTE: While any hyperlinks included in this clause were valid at the time of publication, ETSI cannot guarantee their long term validity.

The following referenced documents are not necessary for the application of the present document but they assist the user with regard to a particular subject area.

- [i.1] ETSI EN 300 019-1-1: "Environmental Engineering (EE); Environmental conditions and environmental tests for telecommunications equipment; Part 1-1: Classification of environmental conditions; Storage".
  - [i.2] ETSI EN 300 019-1-3: "Environmental Engineering (EE); Environmental conditions and environmental tests for telecommunications equipment; Part 1-3: Classification of environmental conditions; Stationary use at weather protected locations".
  - [i.3] ETSI EN 300 019-1-4: "Environmental Engineering (EE); Environmental conditions and environmental tests for telecommunications equipment; Part 1-4: Classification of environmental conditions; Stationary use at non-weather protected locations".
  - [i.4] ETSI EN 300 019-1-8: "Environmental Engineering (EE); Environmental conditions and environmental tests for telecommunications equipment; Part 1-8: Classification of environmental conditions; Stationary use at underground locations".
  - [i.5] Void.
  - [i.6] Void.
  - [i.7] HD 60364-1: "Low-voltage electrical installations - Part 1: Fundamental principles, assessment of general characteristics, definitions", produced by CENELEC.
  - [i.8] ETSI EN 302 999: "Safety; Remote Power Feeding Installations; Safety requirements for the erection and operation of information technology installations with remote power feeding".
  - [i.9] ENISA: "Power Supply Dependencies in the Electronic Communications Sector Survey, analysis and recommendations for resilience against power supply failures" - December 2013.
  - [i.10] CEER (Council of European Energy Regulators): "Benchmarking Report 5.2 on the Continuity of Electricity Supply" - Ref: C14-EQS-62-03 (12 February 2015).
- NOTE: Available at <https://www.ceer.eu/documents/104400/-/-/cbc48e6a-5d5e-a170-ae1d-7b7b298d46a4>.
- [i.11] AEEGSI report 16<sup>th</sup> November 2015.
- NOTE: Available at [www.autorita.energia.it/allegati/com\\_stampa/15/151116cs.pdf](http://www.autorita.energia.it/allegati/com_stampa/15/151116cs.pdf).
- [i.12] ETSI TS 103 553-1: "Environmental Engineering (EE); Innovative energy storage technology for stationary use; Part 1: Overview".
  - [i.13] IEC EN 60950-21: "Information technology equipment. Safety. Remote power feeding".
  - [i.14] IEC EN 60950-22: "Information technology equipment. Safety. Equipment installed outdoors".
  - [i.15] IEC EN 62368-3: "Audio/video, information and communication technology equipment - Part 3: Safety aspects for DC power transfer through communication cables and ports".
  - [i.16] Recommendation ITU-T L.1001: "External universal power adapter solutions for stationary information and communication technology devices".
  - [i.17] IEC EN 62368-1: "Audio/video, information and communication technology equipment - Part 1: Safety requirements".



- [i.18] Directive 2002/22/EC of the European Parliament and of the Council of 7 March 2002 as amended by Directive 2009/136/EC of the European Parliament and of The Council of 25 November 2009, in particular regarding the Article 23 provisions.
- [i.19] ETSI EN 303 215 (V1.3.1) (2015-04): "Environmental Engineering (EE); Measurement methods and limits for power consumption in broadband telecommunication networks equipment".
- [i.20] EN 60896-2: "Stationary lead-acid batteries - General requirements and methods of test - Part 2: Valve regulated types", produced by CENELEC.
- [i.21] TR 62102: "Electrical safety - Classification of interfaces for equipment to be connected to information and communications technology networks", produced by CENELEC.
- [i.22] Void.
- [i.23] Recommendation ITU-T L.1220 (2017-08): "Innovative energy storage technology for stationary use - Part 1: Overview of energy storage".
- [i.24] EN 60950-1: "Information technology equipment - Safety - Part 1: General requirements", produced by CENELEC.
- [i.25] Recommendation ITU-T L.1202 (2015): "Methodologies for evaluating the performance of an up to 400 VDC power feeding system and its environmental impact".
- [i.26] [ETSI ES 203 408 \(V1.1.1\) \(2016-12\)](#): "Environmental Engineering (EE); Colour and marking of DC cable and connecting devices".
- [i.27] Broadband Forum TR-301.

---

## 3 Definition of terms, symbols and abbreviations

### 3.1 Terms

For the purposes of the present document the following terms apply:

**access network:** part of a telecommunications network between the Network Termination/Access Gateway and the first switching unit

**backfeeding or reverse powering:** powering architecture that can supply power to access network units from the customer through its final distribution access copper pair

NOTE: Access network units may be ONU, ONT or remote DSL units.

**centralized powering:** remote powering in which the remote feeding source is located in a telecommunications centre

**cluster powering:** remote powering of a cluster of equipment (1 to n items of equipment), in which the remote feeding source is located outside a telecommunications centre

**electric energy provider:** provider of electrical energy from the public grid (mains)

**ES1, ES2, ES3:** See IEC EN 62368-1 [i.17].

**interface A:** -48 V power interface at input of Telecom/ICT equipment with voltage range and other electrical specifications defined in ETSI EN 300 132-2 [2]

**interface A1:** up to 400 VAC rms power interface at input of Telecom/ICT equipment with voltage range and other electrical specifications defined in ETSI EN 300 132-1 [1]

**interface A3:** up to 400 VDC power interface at input of Telecom/ICT equipment with voltage range, and other electrical specifications defined in ETSI EN 300 132-3 [11]

**Local Power Unit (LPU):** power supply equipment whose function is to supply a telecommunication equipment situated at the same location

NOTE: It is generally locally connected to the mains and provides DC or AC voltage output to feed telecommunication equipment.

**local powering:** powering principle of a telecommunications equipment by a (dedicated) power unit implemented in the same location

**primary circuit:** See IEC EN 62368-1 [i.17].

**protective device selectivity:** coordination of the operating characteristics of two or more protective devices to ensure faulty equipment is safely disconnected with no or limited impact on other parts of the system

**PS1, PS2, PS3:** See IEC EN 62368-1 [i.17].

**Remote Feeding Telecommunication (RFT) circuit:** secondary circuit within the equipment, intended to supply or receive DC power via a telecommunication network at voltages equal to or exceeding the limits for TNV circuits, and on which overvoltages from telecommunication networks are possible

**Remote Power Unit (RPU):** unit, powered by the grid or by a DC power system delivering -48 V or up to 400 VDC, which supplies remote DC on power lines to distant Telecommunication Equipment (TE) e.g. radio unit or RPR

**Remote Power Receiver (RPR):** unit receiving remote DC from RPU through power lines and converting it to input power interface of a TE or a radio unit

NOTE: The RPR may be an external unit with an adapted power interface (e.g. -48 V) or an integrated function of a telecommunications equipment.

**Remote Powering (RP):** power feeding of a telecommunications equipment by a remote power circuit

NOTE: Such a circuit consists of a remote power unit, distribution wiring, and fed receivers.

**RFT-C circuit:** RFT circuit which is so designed and protected that under normal operating conditions and single fault conditions the currents in the circuit do not exceed defined values

**RFT-V circuit:** RFT circuit which is so designed and protected that under normal operating conditions and single fault conditions the voltages are limited and the accessible area of contact is limited

**secondary circuit:** See IEC EN 62368-1 [i.17].

**SELV circuit:** See EN 60950-1 [i.24].

**TLC network and service provider:** provider of telecommunications network services

**TN-C:** See HD 60364-1 [i.7].

**TN-S:** See HD 60364-1 [i.7].

**TNV circuit:** See EN 60950-1 [i.24].

**TT:** See HD 60364-1 [i.7].

## 3.2 Symbols

$I_1, I_2, I_3, I_4, I_5, I_6,$	power interface
L-	Power line of negative potential polarity
L+	Power line of positive potential polarity
S	Signal
S/P <sub>filter</sub>	Filter separating signal S and power P

### 3.3 Abbreviations

For the purposes of the present document, the following abbreviations apply:

A <sub>bat</sub>	Autonomy of a battery
AC	Alternating Current
AN	Access Node
ANU	Access Network Unit
B	Battery
CB	Circuit Breaker
CO	Central Office
CPE	Customer's Premises Equipment
DC	Direct Current
DC/DC	Direct Current/Direct Current

NOTE: DC/DC are used in general in expression such as DC/DC converter or DC/DC conversion.

DSL	Digital Subscriber Line
EC <sub>bat</sub>	Energy Capacity of a battery
EMC	ElectroMagnetic Compatibility
FTTB	Fibre To The Building
FTTC	Fibre To The Curb
FTTCab	Fibre To The Cabinet
FTTdP	Fibre To The distribution Point
FTTH	Fibre To The Home
HD	Harmonization Document
ICT	Information & Communication Technology
IEC	International Electrical Committee
IT	Information Technology
ITU-T	International Telecommunication Union - Telecommunication standardization sector
LED	Light Emitting Diode
LPU	Local Power Unit
LV	Low Voltage
MDF	Main Distribution Frame
MTBF	Mean Time Between Failure
MTTR	Mean Time To Repair
NGA	Next Generation Access
ONT	Optical Network Termination
ONU	Optical Network Unit
P	Power

NOTE: Indices can be used associated with P as P<sub>indice</sub> in some clauses to clarify which power P is used in formula.

PD	Powered Device
PG	Power Gathering
PM	Powering Method
PSE	Power Sourcing Equipment
PSTN	Public Switched Telephone Network
R	Rectifier
RFT	Remote Feeding Telecommunication
RFT-C	Remote Feeding Telecommunication-Current
RFT-V	Remote Feeding Telecommunication-Voltage
RP	Remote Power
RPF	Remote Power Feeding
RPR	Remote Power Receiver
RPU	Remote Power Unit
SAIDI	System Average Interruption Duration Index
SAIFI	System Average Interruption Frequency Index
SELV	Safety Extra Low Voltage
TC	Telecommunication Centre
TE	Telecom Equipment

TLC	TeLecommuniCation
TNV	Telecommunication Network Voltage
UPS	Uninterruptible Power Supply
VRLA	Valve Regulated Lead Acid
Vrms	Volt root mean square

---

## 4 Powering configurations

### 4.0 General

Next Generation Access (NGA) networks induce changes in the powering model and in the need of local back-up, when compared to traditional access networks centre where the back-up is obtained by battery alone or with back-up generator source (Diesel, fuel cell)

Both fixed and mobile NGA networks, usually, require local powering of access network active equipment that are installed outside Central Offices and closer to the end users premises, Typical NGA scenarios are fiber-based FTTH, hybrid FTTC/FTTCab, FTTdP and FTTB architectures.

The new local powering scenario of fibre-based or hybrid fibre/copper NGA networks of a public Telecom networks and services provider, shall include back-up measures in order to ensure to comply with continuity, availability and reliability requirements defined by European regulation [i.18]. But for FTTB, FTTC/FTTCab, FTTdP with the increasing deployment of a great number of distributed active small cabinets, that can be installed inside buildings (FTTB) or in the street (FTTC, FTTCab), the basic power supply backup autonomy has to be optimized, due to a large number of small active cabinets to be installed at optimized costs and dimensions. Only when it's required for some service offers, a long back-up autonomy is obtained by local battery extension or alternatively by remote powering solution proposed to avoid local energy storage.

When a back-up is required, for defining its autonomy and its technology, the global availability and reliability of NGA networks and the AC mains failure rate and availability are considered. In fact, AC mains statistical analysis have shown in years 2000 to 2015 improvements of availability in many European countries. The NGA equipment availability have also been improved compared to the traditional network technologies, as a result, the general availability of access network is improved even with very limited or no local back-up (see annex A).

These considerations also apply to active Network Terminations like routers and/or VoIP access gateway installed and powered inside end users' premises (or inside end users' building).

Electrical energy providers have responsibility for electricity continuity and performances are reported for example in [i.10] and [i.11]. The failures and blackout risks apply to all energy customers included TLC providers. This influences the main characteristic features of the different powering architectures of access network equipment including two very important items:

- The point of connection to electric grid because the active TE of the NGA networks are changing in location. In TLC site they are powered by TLC connection to grid. When distributed they can be remotely DC powered from a TLC site connected to the grid. NGA equipment can also be local Network Terminations and Access Gateway, e.g. CPE installed inside an end users' premises powered by himself or at a short distance also powered by the customer by using a reverse powering solution.
- The responsibility and location for power back-up when it can be provided. The entity that is in charge can be electrical energy providers, TLC network and service providers or end users. The location can be inside big cabinet, Telecom Central Office, broadband local exchange etc. For NGA active street cabinets, in particular in the case of a large number of small street cabinets, battery backup are not mandatory.

As a consequence the definition of the optimal powering and back-up of equipment of the access network needs to consider three main parts:

- 1) the Telecommunication Centre (TC) including local exchange site (e.g. broadband access node);
- 2) the access network (the area between the Telecom Centre or local exchange and the Customer's Premises);
- 3) the Customer's Premises Equipment (CPE).

## Powering architectures

Active equipment of access networks can be powered:

- remotely from a telecommunications centre (centralized powering);
- from a power supply node (cluster powering);
- locally from the mains (local powering);
- from renewable sources (PV, wind etc.).

NOTE: Any of the three main powering architectures preferably may be combined with renewable energy sources, such as solar panels.

Inside these three main powering architectures, several configurations of powering are used. They are summarized in the clauses from 4.1 to 4.2 and in the figures 1, 2 and 3 by the acronyms PM1 to PM 10 (for powering).

## Power back-up

Today, innovative NGA networks are based on grid local powering and/or end users provided local powering (home power or reverse powering solution) DC remote powering is used as an alternative to avoid local energy storage when required.

The powering availability, continuity and reliability performance are in principle based on the performance that electrical energy providers are able to assure, also complying with energy regulation requirements as big local battery are not practicable and is not required. Considering this short back-up, in annex A, a medium availability and reliability performance for NGA networks, including the grid power supply continuity statistical component, is illustrated: fibre-based NGA networks have better reliability performance than traditional copper based networks, even including electricity blackout condition component. Further improvement of the grid power supply continuity by electricity providers could be appropriate also to better protect NGA equipment.

For service, which needs to provide an available service even in the case of a mains outage, a power back-up unit can be located either in the remote power source or in the equipment powered.

For NGA networks cabinets, service providers may provide protection for grid power supply fluctuation, micro-interruptions and short interruptions (e.g. of order of seconds or minutes).

Regarding power backup for big site (e.g. Central Office) or for local exchange site, clauses 4.1 to 4.2 detail the different installation configurations.

## Location of the Telecom Equipment (TE)

On the figures 1, 2 and 3 of the following clauses, the TE in access network is schematically represented in the field. These figures mean that the TE can be implemented in different types of locations:

- in a customer's Premises;
- in a building, public or private;
- in an indoor cabinet;
- in a street cabinet;
- on a pole or tower or street lamp;
- in a telecommunications manhole, etc.

The TE provides services for several customers or for one professional customer.

On figure 3, the TE can be located at customer's Premises and provides services for only one private customer.

## Power interfaces locations

Example of power interface locations are illustrated in figure 1, figure 2 and figure 3.

Seven power-feeding interfaces location ( $I_n$ ) are mentioned in the following clauses. They are as follows:

- $I_0$  = Power interface between a -48 V/-60 V power plant and the fed equipment in a telecom centre. It shall comply with the interface "A" according to ETSI EN 300 132-2 [2].
- $I_1$  = Power interface between the public mains (commercial AC) and the fed equipment. It shall comply with the A1 voltage interface defined in in ETSI EN 300 132-1 [1].
- $I_2$  = Power interface at the output of a source (Remote Power Unit (RPU) or TE) feeding a remote power line. It shall comply with clause 7.
- $I_3$  = Power interface at the input of a distant Remote Power Receiver (RPR/TE), receiving energy from a remote power line. It shall comply with clause 7.
- $I_4$  = Power interface between a local power unit and the fed equipment. It can be  $I_0$  or  $I_5$  or different e.g. 5 or 12V for small power TE. When using 5 or 12V, the universal power adapter should be as defined in [i.16].
- $I_5$  = Power interface between the equipment in a telecom centre or (broadband) local exchange or in a cluster powering site. It shall comply with one of the following interface:
  - interface "A" standardized in ETSI EN 300 132-2 [2]; or
  - interface "A3" standardized in ETSI EN 300 132-3 [11].
- $I_6$  = Power Interface from the customer. Voltages up to a maximum magnitude permitted by IEC EN 62368-1 [i.17] or IEC 62368-3 [3] can be used when transmitting power over telecom pair at interface  $I_6$ .

## 4.1 Remote powering architectures

### 4.1.1 Centralized powering architecture configurations

The different power supply configurations are detailed in figure 1.

The output of the power source of a remote TE is defined at interface  $I_2$ .

It comes from a centralized TE (PM1a, PM2a) or from a specific remote power unit (RPU in PM1b, PM2b, PM3a, PM3b). The remote power unit consists of protection and distribution devices and, possibly, power conversion equipment.

The input of the TE or RPU can be the interface  $I_0$  (-48 V A interface defined in ETSI EN 300 132-2 [2]) or interface  $I_5$  (up to 400 VDC A3 interface defined in ETSI EN 300 132-3 [11]). This uninterrupted power is generated from AC Interface I1 located in the telecommunication centre defined in ETSI EN 300 132-1 [1].

In some cases, the TE of the access network may be equipped with a battery providing additional power in periods of heavy traffic (PM3). This battery is recharged by the remote power supply during periods of light traffic.

In PM3b, the RP line receiver function (RPR) is external to the radio unit.

In the case of up to 400VDC voltage mode RPU/RPR architecture, other architecture are possible with multiple RPU or RPR on a line as detailed in clause 7.2.3.3.

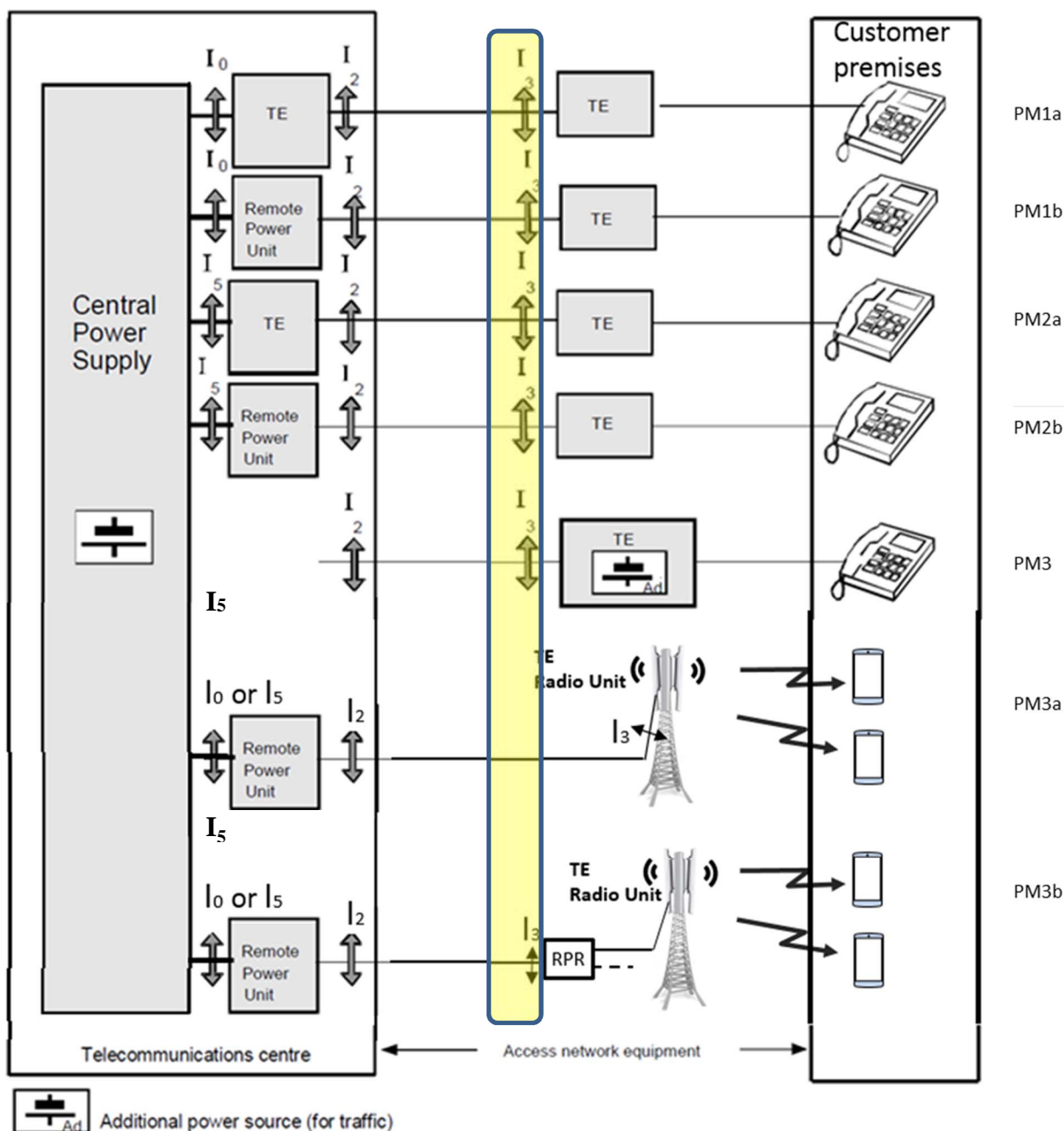

Figure 1: Centralized powering configurations

#### 4.1.2 Cluster powering architecture configurations

The different possible power supply configurations are detailed in figure 2. The remote power source, called Remote Powering Unit (RPU), serves a group of distant telecommunications equipment, from 1 to  $n$ . The RPU is installed in a location (building, outdoor cabinet, manhole, etc.) which is distinct from the centralized TE's building, access network TE cabinet or access network TE manhole. The telecom service is backed up by batteries located either at the RPU (remote powering with back-up at source, PM4) or in the telecommunications equipment (remote powering with local back-up, PM5, PM5a, PM5b, PM5c, PM5d).

In PM5c and PM5d, the RP line receiver function (RPR) is external to the radio unit.

In the case of RPU/RPR architecture, other architecture are possible with multiple RPU or RPR on a line as detailed in clause 7.

In the case of NGA networks, local long time power blackout protection with batteries is not a practical and sustainable measure, at street cabinet level. This clustered scenario could be considered to concentrate local powering source and back-up energy storage, and also to optimize electricity provider provision.

The voltage on  $I_2$  and  $I_3$  are defined in clause 7 and follows limits of clause 10.1.

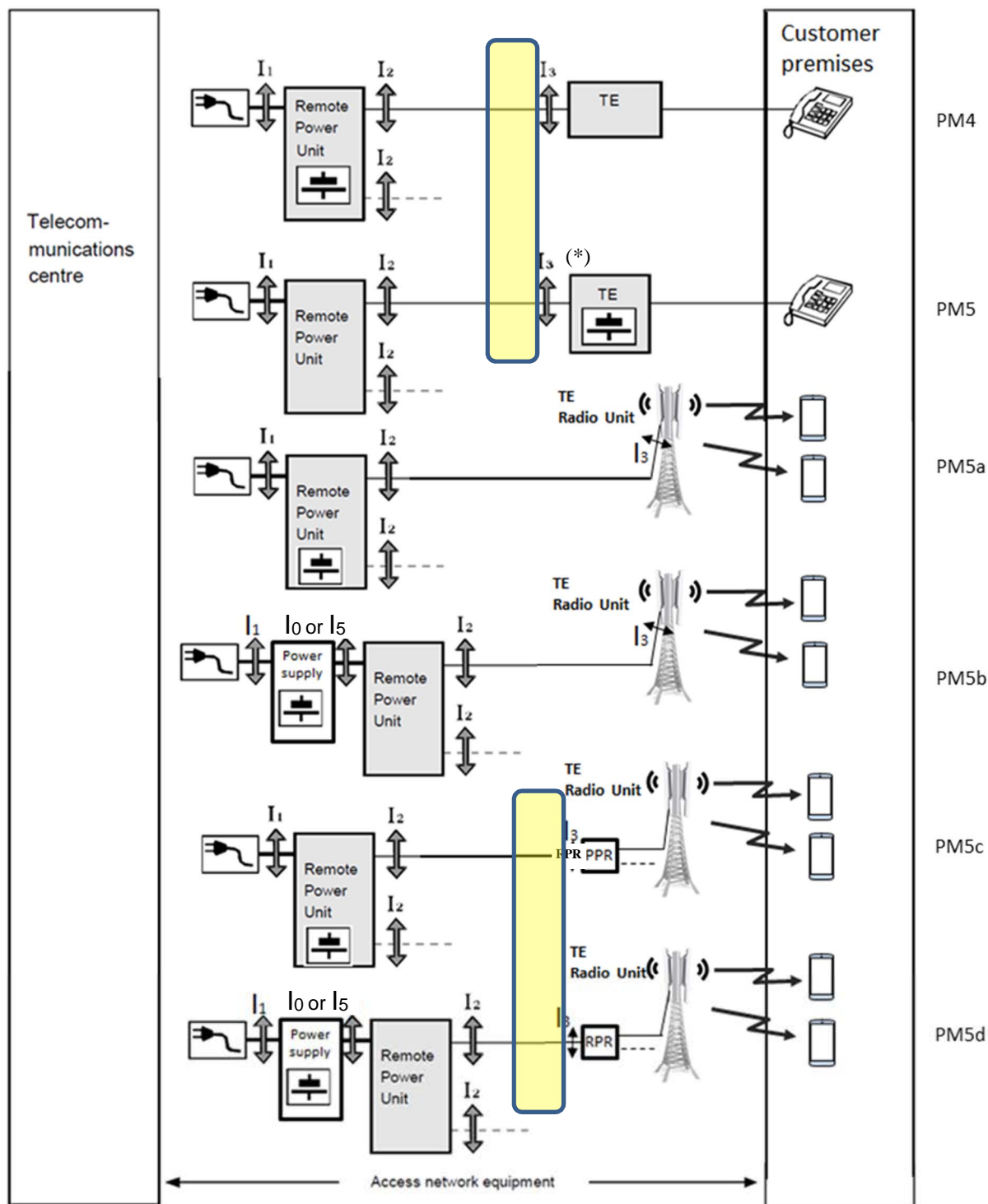

(\*) only a filtering of short dips is required in NGA architectures. Battery is not imposed

Figure 2: Cluster powering configurations



## 4.2 Local powering architecture configurations

### 4.2.1 TE of access network, common to several customers

The different possible local power supply configurations are detailed in figure 3. They are the following two basic types:

- The telecommunications equipment is powered by a Local Power Unit (LPU in PM6) by interface  $I_0$  or  $I_5$  providing the functions of short time protection and power conversion. It is either housed in the telecommunications equipment rack or installed in an independent mounting, but always in the same building or location as the TE.
- The telecommunications equipment is powered directly from the mains at Interface  $I_1$  (PM7). It includes power conversion equipment with short hold-up time or optional back-up.

In the case of NGA networks, long time power blackout protection with batteries is not a practical and sustainable solution, at street or building cabinet level compared to the case of big site or in local exchange site where the battery/UPS availability could be ensured.

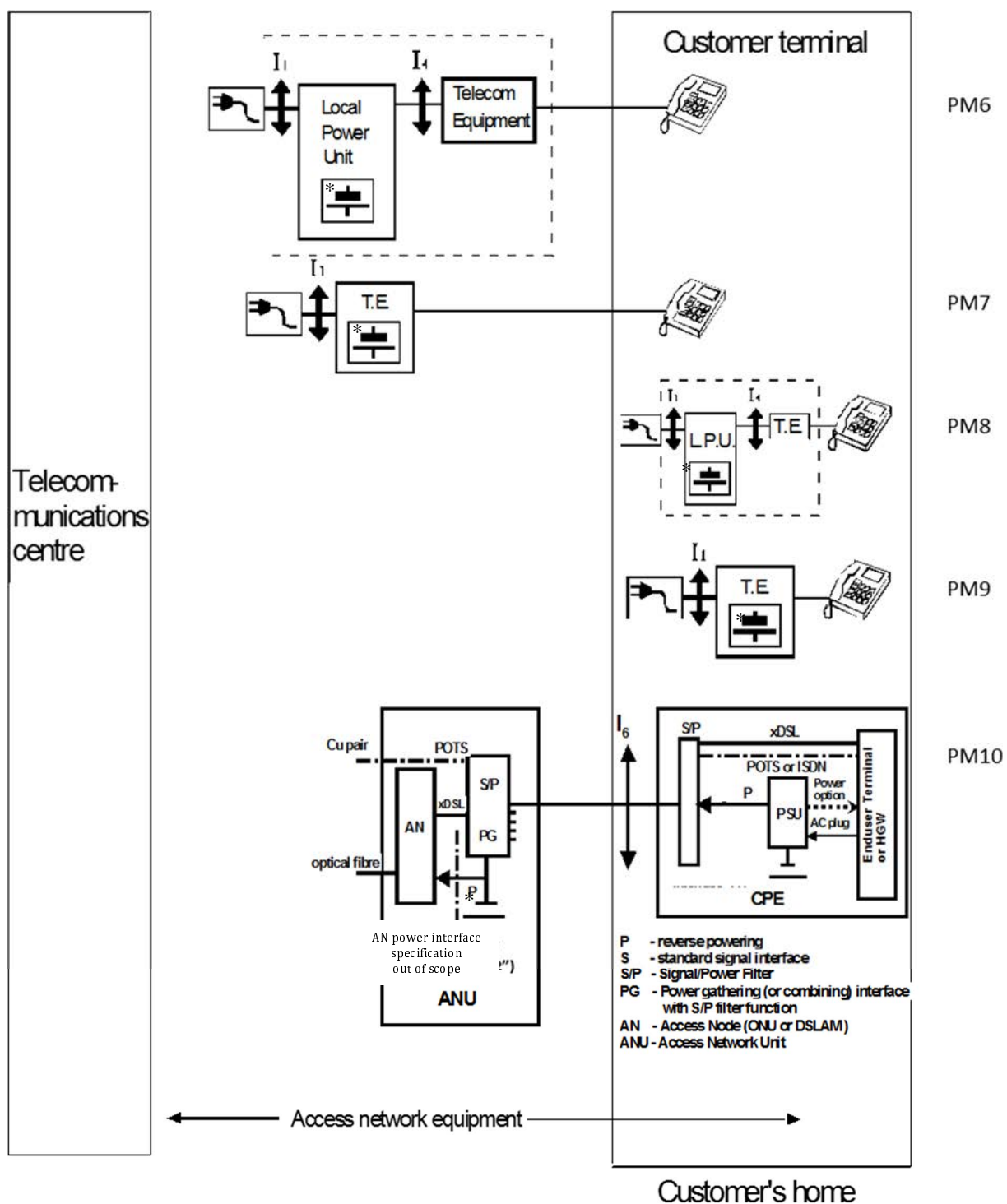

(\*) battery not required in NGA architectures

**Figure 3: Local powering configurations**

#### 4.2.2 TE of access network, at customer premises

The TE is located in a customer's home and provides services for a single private customer. Two types of power feeding are defined in local powering architecture:

- the telecommunications equipment is powered (interface  $I_4$ ) through a Local Power Unit (PM8) which may additionally provide backup; This LPU can have  $I_0$  or  $I_5$  power input interface;
- the telecommunications equipment is supplied by the end user's  $I_0$  or  $I_5$  power input interface: the only way to provide power back is through a voluntary end user's provided DC or AC UPS (PM9).

## 4.2.3 TE in access network reverse powered from customer premises

### 4.2.3.1 Reference configuration introduction

The TE is an ANU, ONU or remote DSL unit or any kind of access telecom equipment (i.e. Network Terminations, Access Gateway, etc.) between a telecom centre or local exchange and the customer premises and is generally located in FTTB, FTTP or FTTC cabinet or underground chamber or man-hole.

The TE is common to N customers ( $x = \text{Building, Curb, Node, etc.}$ ), and is generally powered through 48 V interface.

In the FTTP configuration one customer feeds one ANU with one or more ports by reverse powering either on a copper twisted pair or on a coaxial cable.

NOTE 1: Broadband Forum TR-301 [i.27] provides the architectural basis and technical requirements for FTTP deployment scenarios.

NOTE 2: The customer power supply PSU in CPE can be powered by AC mains  $I_1$ . Commonly in business customer an AC UPS feeds the  $I_1$  interface or a power station feeds the  $I_0$  (-48 V) or  $I_5$  (up to 400 VDC) interface.

### 4.2.3.2 Wiring and electrical limitation consideration

The power on a telecommunication network copper twisted pair will be compliant under any load condition to relevant applicable safety standards (IEC EN 62368-1 [i.17], IEC 62368-3 [3]).

In addition, when using or reusing Telecom copper pair and any equipment between parts of the link (interconnection arrangements, connectors to devices, etc.) for short distance reverse powering from customer (e.g. some hundreds of meters), the maximum transferred power shall be defined using maximum current limit of the cable class defined in relevant applicable safety standards. ETSI TS 101 548-1 [13] defines voltage limits of reverse power feeding solutions.

When there is more than one PSE connected on the building wiring, the building input to PD should implement power limitation in accordance with relevant safety standards to control additive power. In addition each PSE shall have protection under returning current from other PSE under any conditions.

NOTE 1: To avoid electrical fire risks, power interconnection to building wiring and other connected devices should be power limited in compliance with requirements in the relevant applicable safety standards.

NOTE 2: As interconnection of unknown building wiring parts and other devices is possible on existing Telecom copper pairs circuits, the maximum continuous current from PSE should not exceed 1,3 A.

NOTE 3: These safeguards are equivalent to those applicable for equipment that may not be located in close proximity to each other, such as those associated with Power over Ethernet and similar communication technology cabling.

### 4.2.3.3 Reverse power, voltage and current limits

The powering method PM10 in figure 3, i.e. reverse powering of access network equipment shall comply with ETSI TS 101 548-1 [13].

## 5 Effect of the technologies on the powering strategy

### 5.0 General

Access network involves different technologies such as copper, optical fibre or radio.

Between the exchange and the customer's terminals, the telecom network is achieved as follows:

- either in one single technology (for instance "copper", for a big part of the present network or "optical fibre", for a FTTH network or radio link); or

- in a combination of technologies (hybrid networks: copper/radio network, optical/copper, optical/radio).

Ongoing technology evolution provides more diffused and smaller street cabinets and/or all-fibre access network solutions which is changing the power solutions. In access network, TE Backup batteries of DC power supply or of UPS are more justified for large cabinets or cabinets installed in large TLC sites, due to the evident higher impact of grid interruptions on Telecom services. On the opposite, the back-up has high practical drawbacks when distributed on many small sites, in terms of battery maintenance and replacement, environmental impact, etc. to put in balance of service dependability improvement.

The focus should be on global resulting TE availability and reliability which are intrinsically increased in NGA networks over the traditional access network technology. Local power supply availability has to be included as a component of the global availability of TE.

For more protections requirements against long electrical interruption, it would be more logical for small TE equipment to use other global protection solutions:

- either to rely on the electrical providers reliability performance when possible; or
- when not possible in some countries to rely on remote powering solution. The remote power solution should be preferred to big batteries and encouraged by a simplified regulation.

These access network systems can be divided in two main families (see figure 4) according to the links between the telecom centre and the active equipment, and their consequences on powering:

- Family 1: system connected to a telecom centre by a metallic link. This family includes the copper access.
- Family 2: system connected to a telecom centre by a non-metallic link. This family includes the fibre access network (FTTH), the hybrid fibre/copper access network (FTTCab/FTTC/FTTB), the hybrid copper/radio access network and the radio access network.

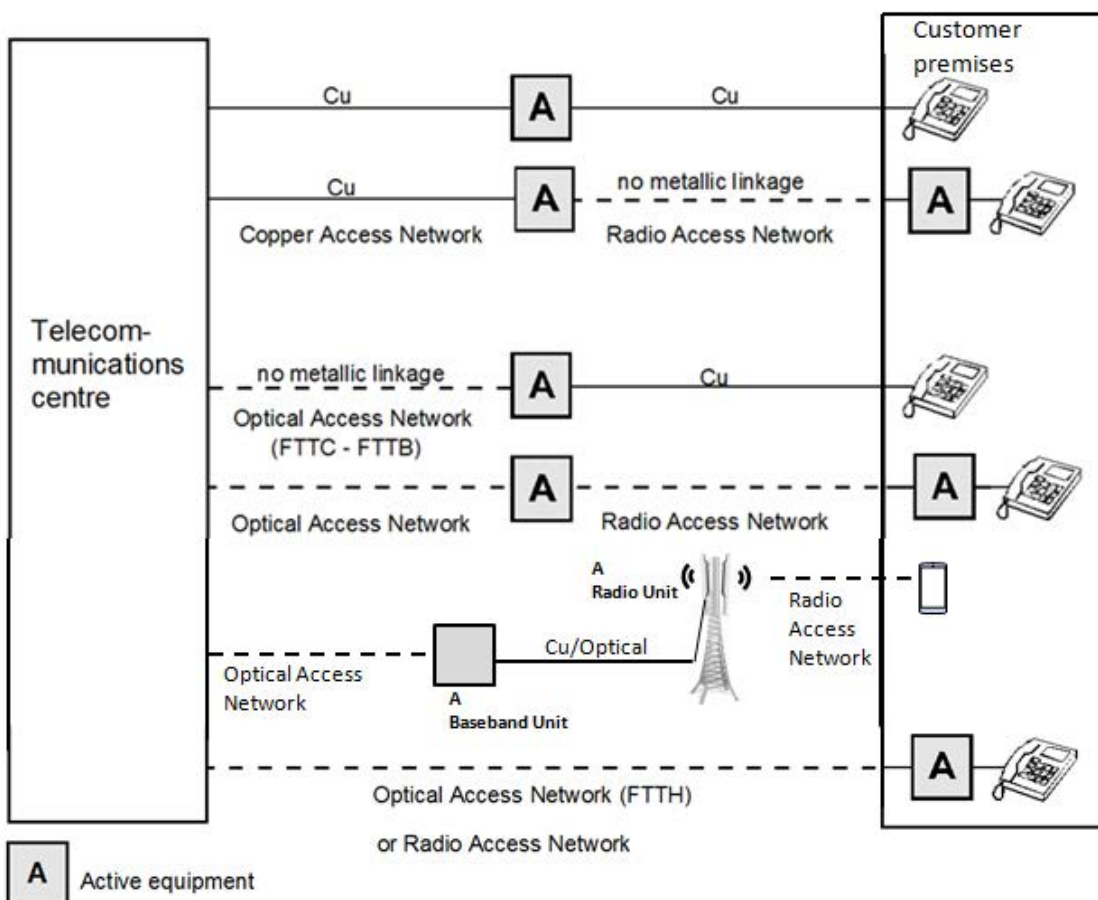

Figure 4: Access network technologies

## 5.1 Powering strategy of family 1: metallic links

The equipment of copper access network is generally powered according to the four principles defined as follows:

- a) due to a metallic link from the telecom centre to the access network equipment, the centralized **powering** (PM1a/PM1b and PM2a/PM2b in figure 1) can be used: remote power source with back-up in the central office and power ducts used by the (existing) copper pair(s). Such a solution can be developed if the power consumption of the equipment is not too high. The output voltage of the power source is defined in clause 7.2;
- b) when the power consumption of the access network equipment is higher, Remote Power Feeding to TE through a power cable or local powering can be used;
- c) when local powering is used, two configurations are defined:
  - the power supply with back-up can be provided by a Local Power Unit (PM6 or PM8 in figure 3). The telecom operator is the provider of the LPU and the requirements at the interface "LPU/Telecom system" ( $I_4$  of figure 3) are defined in clauses 6.2 to 6.4;
  - the power plant with back-up can also be included in the TE (PM7 or PM9 in figure 3). Clause 8 defines the requirements for the power back-up i.e. the conditions for the definition of a back-up time.
- d) for intermediate power consumption, the centralized powering can be completed by a local battery (PM3 in figure 1) which provides an additional power source in operation (discharge) when the traffic increases. Most part of time, the traffic is such that the power provided by remote powering is sufficient and the local battery is in charge. By daily cycles or occasionally, the local battery is used when the traffic increases.

## 5.2 Powering strategy of family 2: non-metallic links

The equipment of the fibre access network, the radio access network, the hybrid fibre/copper access network, the hybrid copper/radio access network and the hybrid fibre/radio access network are generally powered according to the three principles defined as follows:

- a) When no "natural" electrical link connects the telecom centre to the Active Network Unit equipment (ANU), the **local powering** is the recommended solution in FTTB and FTTC. As it is defined in clause 5.1 b), the power supply of the equipment can be provided either by a LPU (PM6 in figure 3) or directly from the mains (PM8 in figure 3). In the first case, the requirements at the interface LPU/ ANU are defined in clauses 6.2 to 6.4. In the second case, the requirements for the power back-up are given in clause 8.
- b) When a lot of active equipment is implemented in one area, it may be cost effective to centralize their power supply in a RPU (located in the same area as the active equipment) as defined for **cluster powering** architecture (see clause 4.2). The power feeding from the RPU to the ANU is generally ensured by dedicated power cables. The requirements on the output of the RPU are defined in clause 7.2.  
 General approach and recommended requirements on viable power protection are given in clause 8.
- c) In some cases, the ANU may be supplied by means of a **centralized powering** architecture (PM1b and PM3a of figure 1). The requirements on the output of the RPU are defined in clause 7.2.

The powering of hybrid fibre/radio access network obeys the same principles than those defined in hybrid fibre/copper access network. The receiving equipment is a fixed part located at the customer's home. It is in any case powered locally (PM9 in figure 3) from the mains.

The fibre access network is characterized by the optical architectures FTTH, FTTB and FTTC.

---

# 6 Requirements for local powering

## 6.1 TE including the power plant

The input voltage of the telecommunications equipment (at interface  $I_1$  of clause 4) is nominal 230 V, 50 Hz.

A power back-up unit with batteries, when applicable, provides continuity of supply in the event of a mains outage or a failure of power equipment. The general recommended requirements of power protection are defined in clause 8.

## 6.2 TE powered by a DC voltage nominal -48 V or up to 400 VDC local power unit

The Local Power Unit (LPU) provides the functions of short time protection and power conversion.

The input voltage of the telecommunications equipment TE is -48 V (interface A) up to 400 VDC (interface A3). It can be  $I_0$  or  $I_3$  or  $I_5$  or  $I_4$ .

$I_0$  interface shall comply with the requirements of interface A in ETSI EN 300 132-2 [2].

$I_5$  interface shall comply with the requirements of interface A3 in ETSI EN 300 132-3 [11].

## 6.3 TE powered by a LPU with a DC voltage other than -48 V or up to 400 VDC

The present document covers DC voltage levels / ranges defined in the -48 V and up to 400 VDC interface standards. Other voltages are not covered in the present document.

## 6.4 TE powered by a nominal AC voltage of 230 V, 50 Hz local power unit

The Local Power Unit (LPU) may be an Uninterruptible Power Supply which provides the functions of protection and power conversion. The input voltage of the TE (at interface  $I_1$  of clause 4) is the nominal AC voltage defined in ETSI EN 300 132-1 [1] which is in Europe 230 V, 50 Hz [4].

---

# 7 Requirements for remote powering

## 7.0 Remote powering solutions

The general architectures of remote powering of TE are presented in figure 1 and 2 for fixed and mobile networks respectively in centralized and cluster powering configurations.

ETSI EN 302 999 [i.8] requirement for erection of remote powering solutions should be considered such as equipment access restriction, off voltage line locking for extra-safe operation, cable and RP equipment marking, circuit faults monitoring. This includes also operational informative recommendations for workers training and instruction information in manuals and on equipment.

The colour and marking of DC cable and connecting devices, should comply with ETSI ES 203 408 [i.26].

A comparative reliability approach is presented in annex C.

## 7.1 Input of the Remote Power Unit (RPU)

In centralized powering, the Remote Power Unit (RPU) can be supplied at its power input interface by the power system of a telecom centre with the following input voltage as defined in clause 4:

- Interface  $I_0$  -48 V. Its characteristics shall comply with the requirements detailed in ETSI EN 300 132-2 [2].
- Interface  $I_5$  up to 400 VDC. Its characteristics shall comply with the requirements detailed in ETSI EN 300 132-3 [11] and ETSI EN 301 605 [14].

In a cluster powering solution, the Remote Power Unit can be supplied at its power input interface by the following input voltage as defined in clause 4:

- interface  $I_1$ , 230 V, 50 Hz that shall comply with ETSI EN 300 132-1 [1];
- interface  $I_0$ , -48 V that shall comply with ETSI EN 300 132-2 [2];
- interface  $I_5$ , 400 VDC that shall comply with ETSI EN 300 132-3 [11] and ETSI EN 301 605 [14]:
  - In some countries outside Europe and for a transition period to the range defined above in steady state, a lower voltage range can exist at the input of the RPU such as 192 V -288 V as indicated in Recommendation ITU-T L.1200 [15]. This can impact the RP line voltage for optimization purpose.

## 7.2 Output characteristics of the Remote Powering system

### 7.2.1 Remote powering output with a RFT-V circuit

When using RFT-V remote powering on telecom pair or coaxial cable, the RFT-V voltage mode defined in EN 62368-3 [i.15] shall be applied.

### 7.2.2 Remote powering output with a RFT-C circuit

When using RFT-C remote powering on telecom pair or coaxial cable, the RFT-C current mode defined in EN 62368-3 [i.15] shall be applied.

### 7.2.3 Remote powering output at up to 400 VDC

#### 7.2.3.0 General consideration on line electrical parameters and operation

The voltage ranges at output of the RPU to RP lines may be different from ETSI EN 300 132-3 [11] interface voltage ranges and are defined in following clauses for steady state, transient state and under operational fault conditions.

#### 7.2.3.1 Steady state output voltage and current

The output voltage on  $I_2$  provided by RPU shall be at maximum of 400 VDC.

In order to use ICT equipment originally intended for 230 VAC, including but not limited to power converters, distribution units, cables, etc., the output voltage of a RPU may for a transition period be limited to maximum 300 VDC.

NOTE 1: In systems, where the RPU voltage is limited to 300 VDC, telecom load equipment may be used with an input voltage also limited to a maximum of 300 VDC.

NOTE 2: For achieving the highest energy efficiency (low loss in the RP line with small copper cross-section), the RPU output at minimum and maximum voltage of the voltage range should be close to 400 VDC e.g. (380 - 390 VDC).

NOTE 3: If the RPR itself feeds a remote TE, a voltage in SELV voltage range may be used.

#### 7.2.3.2 Transient state output voltage

- The voltage on  $I_2$  shall return in the steady state voltage range within 100 ms whatever is the power change between 0 and the maximum line power specified for the RPU line output.
- It shall never exceed:
  - 410 VDC longer than 1s and 420 VDC longer than 10 ms.

- In systems, where the RPU voltage is limited to 300 VDC for a transition period, the transient voltage should never exceed 310 VDC longer than 1 s and 320 VDC longer than 10 ms.

### 7.2.3.3 Architecture of RP distribution for reliable and safe operation management

The distribution lines and installation shall comply with IEC 60364 series [16].

Figure 5 shows the most common remote powering architectures. The ICT product safety is defined in clause 10.

**The basic safety** is covered by basic safety standard and extra safety depends on architecture variation that are all not described in figures 1 and 2:

- 1 cable to each TE: 1 to 1 architecture as shown on figures 1 and 2.
- 1 cable for several TE: 1 to n architecture.
- 1 cable as a reliable power loop with two RPU at each end, to have tolerance to broken line or RPU interruption.
- A line extension by using couple of RPU/RPR for several RP line sections in series (for example at the end of each RP line section a RPR function is powered by a RPU function).
- The architectures are not limited and can consist of combinations of the ones shown in figure 5.
- The safe operation of the ICT products used in the architectures is defined in clause 10. The basic safety operation is covered by basic safety standard (see clause 10.1). However, additional measures for safety and stable operation are given in clause 7.2.3.4.

A fault on one RP line may propagate temporarily as a functional disturbance to other RP lines connected to the same RPU but shall not cause a fault on the central office power supply and on its connected ICT equipment.

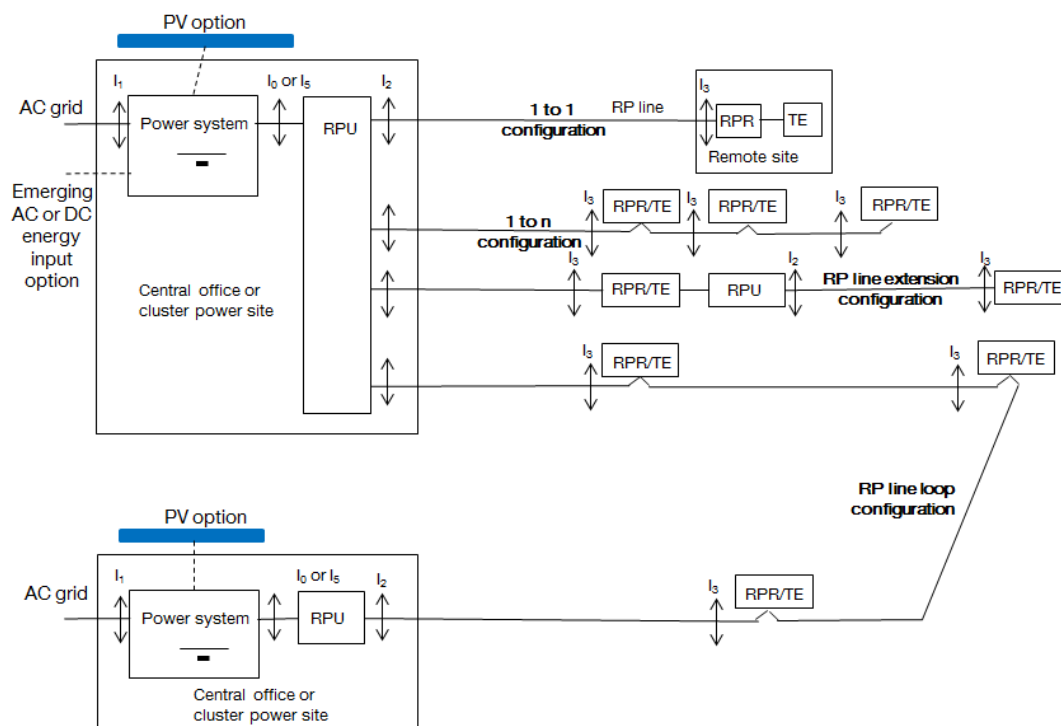

**Figure 5: Details of remote power configurations common options**



### 7.2.3.4 Requirements for stable and safe operation

- Other user requirements on reliability and safety depending on configuration are related to detection and protection solutions to cover overcurrent conditions (short circuit, overloads) on RP line taking protective device selectivity in to account when several RPR are connected:

- RP line wire ground fault (earth leakage)

NOTE 1: An earth leakage may occur when the line isolation is broken somewhere in its path. This happens particularly in wet area or when a person is touching one line conductor. The RP system should have the optional function of opening a RP line automatically, with the equivalent reaction time of a Residual Current Detection circuit breaker.

- RP line short-circuit

In case of short circuit, the current should be limited in less than 5 s at the lower value as possible to reduce fire risk in the short-circuit load.

- RP line overload

A test of 10 % overload over the maximum current is defined in ETSI EN 302 999 [i.8].

- RP line inrush

RPR equipment inrush current shall not trip protective devices recommended by the RPR equipment manufacturer.

NOTE 2: The overload applies after the inrush current phase as defined in ETSI EN 300 132-3 [11].

- RP line in open circuit

The line open circuit should be automatically detected and in that case the voltage should be decreased to the lowest possible level. For example, the line can be powered off.

- Safe start-up

The system should have safe start-up and open circuit detection for the RP line between RPU and RPR. Safe start-up and open circuit detection are not required for the line between RPR and TE. During the safe start-up the RP line should remain at a voltage limited to 60 VDC, until a normal state without line short-circuit or open-circuit is detected.

- There should be also a method, not necessarily part of the product, to locate the open circuit fault along the line which is simplifying maintenance.

NOTE 3: it is highly recommended to have an automatic start-up procedure to avoid costly manual operation. For example, when an operator closes a circuit breaker at RPR level, he does not have to come back to the RPU side to power on manually the RP line.

## 7.3 Input characteristics of remote power receiver

### 7.3.1 RFT-V remote power receiver input in voltage mode

The remote powered receiver equipment (Interface I<sub>3</sub> of clause 4) shall at least accept an input voltage in the range of values between the nominal output voltage of the RFT-V Remote Power Unit and half of that value.

Within the accepted voltage range, the remote power receiver shall be able to deliver the same defined power whatever is the voltage.

### 7.3.2 RFT-C remote power receiver input in current mode

The remote powered receiver equipment (Interface I<sub>3</sub> of clause 4) shall at least accept an input voltage in the range of values between the nominal output voltage of the RFT-C Remote Power Unit and half of that value.

The input voltage is constant, for the output voltage of the remote power unit varies in value dependent on the line length and the number of receiver equipment in series.

### 7.3.3 Remote Power Receiver (RPR) input

The voltage at input of a Remote Power Receiver unit (RPR) from a RPU shall stay in the following range at interface I<sub>3</sub>:

- Range: 260 - 400 VDC

During a transition period a narrow voltage range 192 - 288 VDC may be used for ICT equipment originally intended for 230 VAC, including but not limited to power converters, distribution units, cables, etc.

NOTE 1: Above allows the use of RPR based on power supply designed for AC powering single phase narrow voltage range as defined in ETSI EN 300 132-1 [1] and stay in same creepage and clearance distance.

NOTE 2: The low voltage limit of the range is useful for unregulated range, for enabling very long distance remote powering and for handling power transient (e.g. due to inrush current), but it is recommended to operate as much as possible with a limited voltage drop in the RP lines to avoid too much energy losses.

### 7.3.4 Remote Power Receiver (RPR) output

The output of the RPR, should be current limited with an overcurrent protection so that above 100 % load the voltage falls down using "hiccup mode" or "fold back curve" or a combination of both. The output voltage should stay close to a constant voltage (i.e.  $\pm 5$  %) under a load of 0 % to 100 % of the rated power.

The system design shall ensure that in the case of multiple RPR on the same RP line, none of the RPR should shut down at any defined load during a transient peak power on one of the RPR (e.g. due to inrush current at start-up of TE).

NOTE: Automatic restart should be provided to recover from these protective areas.

---

## 8 Power source interruption management

As illustrated in clause 4, the situation is evolving from power supply uninterrupted energy based on relatively long energy back-up to short power dip, voltage fluctuation and sag filtering (e.g. of order of seconds or minutes) with new access network technologies; the long autonomy batteries should not be generalized to an highly increasing number of active access equipment considering environmental and cost sustainability and NGA fibre-based network TE reliability and restart time improvement, with respect to the traditional Telecom technology and public grid increased basic availability and reliability defined by electricity providers adhering to the energy sector specific regulation. (see annex A).

Inside Telecom Centres or local exchanges or large dimension cabinets, the battery of DC station or AC UPS based remains actually considered as a viable and sustainable solution. Only for specific situations of poor power availability form public grid (long time blackout), the adoption of an energy backup (e.g. with large batteries) could be considered also for small NGA cabinets.

In the case of centralized remote powering that is localized inside Telecom Centres or local exchanges, a standby source, such as a turbine or motor-driven generating set, could possibly supplement and reinforce battery back-up of supply.

Annex B gives information on battery sizing.

NOTE: For optimization purpose, it is recommended to adapt energy storage solutions based on overview and selection methods of the Recommendation ITU-T L.1220 [i.23].

## 9 Power management

The operating status of the power supply and back-up equipment powering an access network equipment, shall be known by the network operator to enable appropriate maintenance to be carried out. The power management data detailed in this clause are required and available for remote management. One option is a connexion through the Telecommunications Management Network to the network or the Network Management System.

The management interface at centralized power site, cluster site, LPU or ANU shall comply with ETSI ES 202 336-1 [12] and with ETSI ES 202 336-8 [17] for the remote powering systems.

According to the different powering architectures, the power management shall follow the requirements given in table 1.

**Table 1: General management requirement for all powering configurations**

Architectures	Management requirements
<b>Centralized Powering:</b> PM1a/PM1b/PM2a/PM2b/PM3/ PM3a, PM3b	The TE of access network does not ensure the management of the centralized powering, but TE power supply failures of each TE shall be detected and alarms shall be transmitted by the centralized powering equipment to the management system.
<b>Local Powering:</b> PM6/PM7 PM8/PM9	The TE shall provide at least 2alarms (category 2, 3) to the LPU The LPU shall provide 2 alarms synthesis (category 2, 3) in addition to detailed alarms. The LPU shall transmit TE alarms and its own alarms to the management system. Local visual indication of alarms is required (e.g. by LED) for each RP line Other information may be transmitted such as battery test results, or grid failures statistics.
<b>Cluster Powering:</b> PM4 PM5 /PM5a /PM5b /PM5c /PM5d	The TE shall provide at least 2 alarm synthesis (category 2, 3) to the RPU. The RPU shall provide 2 alarms synthesis (category 2, 3) in addition to detailed alarms. The RPU shall transmit the TE alarms and its own alarms to the management system. Local visual indication of alarms is required (e.g. by LED).for each RP line. Other information may be transmitted such as battery test results, or grid failures statistics.
<b>Reverse powering:</b> PM10	The reversed power TE (e.g. ANU, ONU or ONT of FTTPd) shall provide an alarm to the Telecom Management Network, when the reverse power is interrupted. Without battery, there should be a sufficient energy reserve to send this message sometime called dying gasp. When there is a battery in the ANU, ONU or ONT, alarms are battery discharge for a defined time due to lack of reverse power or failure of DC/DC converter (alarm 8, table 2) and battery voltage very low (alarm 6, table 2). The ANU shall provide 2 alarms synthesis (category 2, 3) in addition to detailed alarms. Other information may be transmitted such as battery test results (alarm 7). Local visual indication of alarms is required (e.g. LED) for local ANU alarms or reverse power lack.

For configuration PM 4, 5, 6, 7, 8, 9, table 2 gives the information (failure events) which shall be controlled and the resulting alarms which should be communicated to the operator by the system via the management network.

Alarms 2, 3, 5 and 6 may be combined together and alarms 4, 7 and 8 too if, locally, a visual check of the component involved or if a simple test procedure makes it possible to identify the fault. The consequences of alarms may be determined by the operator.

**Table 2: Alarms of LPU configuration (PM6, PM7, PM8, PM9)**

<b>Alarm- Warning</b>	<b>Category</b>	<b>Failure events</b>
1) Loss of input power	1	- Mains outage
2) Power module failure number 1	3	- Failure of a power conversion module (rectifier, DC/DC converter etc.) with no redundancy - Failure of two modules of a (n+1) redundant system
3) Failure of a protection device	3	- Opening of a protection device (circuit breaker, fuse, relay contact etc.), except one integrated in a conversion module
4) Power module failure number 2	2	- Failure of one power conversion module (rectifier, converter, etc.) in a (n+1) redundant system
5) Monitoring unit alarm	3	- Failure of the power management and monitoring unit (management of battery charge etc.), if present. In the event of a monitoring unit failure, fall-back mode operation is assured to ensure continuity of supply
6) Battery voltage too low	3	- Voltage level, characteristics of a significant level of discharge (excluding test)
7) Battery test alarm	2	- Test result: end of service life of battery
8) Lack of reverse power or battery discharge	2	- Battery voltage or current showing discharge due to internal failure or lack of reverse power

NOTE 1: Three levels of alarms are defined in tables 1 and 2:

- a) Category "1" Event: An event happens which normally does not need a maintenance intervention of the network operator.
- b) Category "2" Alarm: The failure event need a maintenance intervention of the network operator but the service can be ensured without discharging the battery.
- c) Category "3" Alarm: The failure event need a not-delayed maintenance intervention of the network operator.

NOTE 2: In the cluster powering, due to the power management, the remote power unit and the distant TE's units cannot be designed independently. The means to transfer the information from the RPU to the distant Network Units can be very different: implementation of one Network Unit close to the RPU (which feeds other distant Network Units), specific information cables in parallel with power cables, information on current carrier, etc.

**Table 3: Alarms of RP configurations (PM4, PM5 / PM5a / PM5b / PM5c / PM5d)**

Alarm- Warning	Category	Failure events
RPU or RPR converter failure	The category of each alarm can be set depending on operator choice.	Failure of power conversion module (rectifier, DC/DC converter etc.).
RP line voltage out of range		Voltage level, characteristics of a significant level of battery discharge (excluding test) or a high voltage condition. This includes operation of a voltage protective device e.g. over-voltage.
RP line loss of power / current		Operation of protective device due to a fault condition (or manual operation), open circuit line.
RP line overload		Excessive current due to faulty equipment or too much connected load.
RP line ground fault (detection of earth leakage in IT mode)		Line to ground fault.
RP line in open circuit		Damaged line due to mechanical impact or opening of a protective device.
RPR output voltage fault		Voltage level, characteristics of a significant level of battery discharge (excluding test), high voltage condition or operation of protective device due to line fault.

NOTE 3: Alarm transport of remotely fed equipment is often the responsibility of the system operator.

---

## 10 Safety, EMC, protection

### 10.1 Product Safety

The requirements for safety are outside the scope of the present document. Safety standards are published by CENELEC and IEC.

Table 4 gives information of the relevant standards and voltage category for each power Interfaces defined in the present document that may be override by evolution of safety standard.

NOTE 1: An example of such a product safety standard is IEC EN 62368-1 [i.17].

NOTE 2: For Safety categories of interfaces see TR 62102 [i.21].

NOTE 3: Examples of interfaces are in table 4. For A3 interface, high resistance mid-point grounding is considered as the highest safety and availability choice considering ETSI EN 301 605 [14].

NOTE 4: For earthing and bonding of interface A3 for up to 400 VDC see ETSI EN 301 605 [14].

Table 4: Example Safety Standards

Interface	Category	According to
I <sub>0</sub> (-48 VDC)	ES1	IEC EN 62368-1 [i.17]
I <sub>1</sub> (230 V, 50 Hz)	ES3	IEC EN 62368-1 [i.17]
I <sub>2</sub> or I <sub>3</sub> (-48 VDC)	ES 1	IEC EN 62368-1 [i.17]
I <sub>2</sub> or I <sub>3</sub> (< 60 mA)	RFT-C	IEC EN 62368-3 [i.15]
I <sub>2</sub> or I <sub>3</sub> (max. +140 V or max. +200 V, 10 mA)	RFT-V	IEC EN 62368-3 [i.15]
I <sub>2</sub> or I <sub>3</sub> up to 400 VDC	ES3	IEC EN 62368-1 [i.17]
I <sub>4</sub> (-48 VDC)	ES1	IEC EN 62368-1 [i.17]
I <sub>4</sub> (230 V, 50 Hz)	ES3	IEC EN 62368-1 [i.17]
I <sub>4</sub> (max. +140 V or max. +200 V, 10 mA)	RFT-V	IEC EN 62368-1 [i.17]
I <sub>5</sub> (230 V, 50 Hz)	ES3	IEC EN 62368-1 [i.17]
I <sub>5</sub> up to 400 VDC	ES3	IEC EN 62368-1 [i.17]
I <sub>6</sub> (< 60 V / -60 VDC)	ES 1	IEC EN 62368-1 [i.17]
I <sub>6</sub> (< 120 VDC)	ES2 or ES3	IEC EN 62368-1 [i.17]
NOTE: In table 4, the safety standards IEC EN 62368-1 [i.17] and IEC EN 62368-3 [i.15] are quoted as example. These two standards replace respectively IEC EN 60950-1 [i.24] (but also IEC EN 60950-22 [i.14]) and IEC EN 60950-21 [i.13] but both standards (IEC EN 60950 parts or IEC EN 62368 parts) can be applied for the safety requirements until the stability date defined by IEC or the date of withdrawal defined by CENELEC.		

## 10.2 EMC

The telecommunications equipment shall comply with the relevant EMC standards.

## 10.3 Protection/resistibility

Telecommunications equipment of access network may be installed in very different locations which have nothing to do with telecom centres. The electrical environment is not so controlled and depends on the type of networks (aerial, buried, IT, TT, TN-C or TN-S mains distribution) [i.7].

Equipment which have to be supplied directly from the mains or through a UPS shall be designed to comply with overvoltage categories as they are defined in EN 60664-1 [5] and Recommendation ITU-T K.45 [9], unless additional protection to be provided external to the equipment. Limits for power consumption in broadband telecommunication networks equipment shall comply with ETSI ES 203 215 [10].

## 10.4 Earthing and bonding of access network powering solutions

The bonding and earthing of equipment in access network shall comply with:

- requirements of ETSI EN 300 253 [7] or ETSI EN 301 605 [14] for telecommunication/ICT equipment in a central office; or
- requirements of EN 50310 [6] for information technology equipment in customer premises; or
- Recommendation ITU-T K.35 [8] for an equipment located in remote electronic sites;
- national regulations and electrical installation safety codes where applicable.

The earthing of 400 VDC remote power distribution on power cable defined in clause 7.2.3 shall be of IT system type with earthed high-ohmic Mid-Point (MP) terminal according to ETSI EN 301 605 [14]. For the PE conductor, there are option a) and option b) in the figure 6. Option b) is preferred. Option a) would only be used for very small distance e.g. inside the same site.

The line output earthing arrangement (insulation monitor, earthing fault and alarm) shall be compliant with high-ohmic mid-point grounding requirements of ETSI EN 301 605 [14].

NOTE: Even if both optional system earthing IT and TN-S arrangements outlined in ETSI EN 301 605 [14] fully comply with relevant EN/IEC-standard, the IT earthing system (high-ohmic mid-point grounding) is preferred as an extra safety precaution beyond the minimum level that the TN-S earthing system provides.

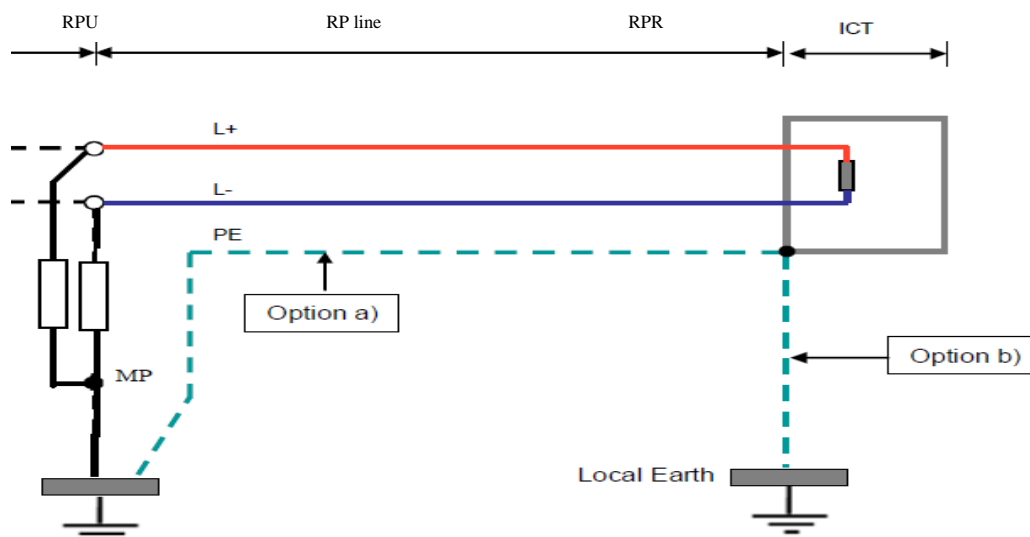

Figure 6: IT earthed high-ohmic Mid-Point (MP) connection of Remote Powering lines

## 10.5 Wiring requirements of remote power feeding to TE through power cable at up to 400 VDC voltage mode

### 10.5.1 Protection against electric shock

Live parts (L+/L-) shall be completely covered with insulation which can only be removed by tools. In order to prevent service personnel from contacting L+ and L- simultaneously, it shall not be possible to access bare parts of the L+ and L- conductors simultaneously.

The rated voltage of power cable from RPU to TE shall comply at least with the system voltage, which are at maximum 400 VDC line to line and 400 VDC with reference to ground.

If an AC cable is used for DC applications its rated Alternating Current (AC) voltage rating, shall be at least 300 Vrms.

NOTE: AC cables are rated for peak AC voltages and thus an AC cable with a 300 Vrms rating has a peak voltage rating of 424 V ( $300 \times 1,414$ ).

## 10.5.2 Protection against fire

The cross-sectional area of power cable shall be adequate for the current they are intended to carry such that the maximum permitted temperature of conductor insulation is not exceeded.

Power cables (L+/L-) shall be protected by over current protective device.

## 10.5.3 Protection against physical damage

The power cable or composite cable (optical fibres + copper conductors) from RPU to TE or RPU shall be protected by conduit or tubing, or armoured cable, or installed out of reach, or installed with obstacles to prevent unintentional contact with Power cable but not intentional contact, which means:

- 1) access can only be gained by electrician or by instructed persons who have been instructed about the reasons for the restrictions and about any precautions that shall be taken; and
- 2) access is through the use of a tool or lock and key, or other means of security, and is controlled by the authority responsible for the location.

---

# 11 Environmental conditions

The access network powering equipment solution defined in the present document shall comply with the environmental class adapted to the location defined by the user for each application.

ETSI EN 300 019-1-1 [i.1] defines the classification of the environmental conditions. ETSI EN 300 019-1-3 [i.2] specifies the classification of environmental conditions - Stationary use at weather protected locations.

ETSI EN300 019-1-4 [i.3] specifies the classification of environmental conditions - Stationary use at non-weather protected locations and ETSI EN 300 019-1-8 [i.4] for stationary use at underground locations. Table 5 gives the ETSI environmental classes applicable to three main locations for information.

**Table 5: Examples for powering equipment locations (informative)**

Powering Equipment Location	Weather protected locations						
	Class 3.1 Temperature Controlled Locations	Class 3.2 Partly Temperature controlled locations	Class 3.3 Not Temperature controlled locations	Class 3.4 Sites with Heat-trap	Class 3.5 Sheltered locations	Class 4.1 Non-Weather-protected Locations	Class 8.1 Underground locations
<b>Outside plant</b>	-	○	●	●	●	●	●
<b>Inside a building</b>	●	●	●	○	-	-	-
<b>Customer home</b>	●	○	-	-	-	-	-
● Suitable for most cases. ○ Suitable for some cases. - Not suitable for most cases.							



## Annex A (informative): Statistical data on electrical power supply availability, from the Low Voltage (LV) public grid (mains) in various European countries

Statistical data on electrical power supply availability, from the Low Voltage (LV) public grid (mains) in various European countries, can be a relevant element for TE's power supply protection strategy, in an NGA networks context. In the following figures A.1 and A.2, data on public electrical power grid availability, from some European countries, are shown (including Medium Voltage and Low Voltage interruptions - source ETSI TS 103 553-1 [i.12], annex C. Data change from country to country, but a general trend of improvement in power grid availability can be observed.

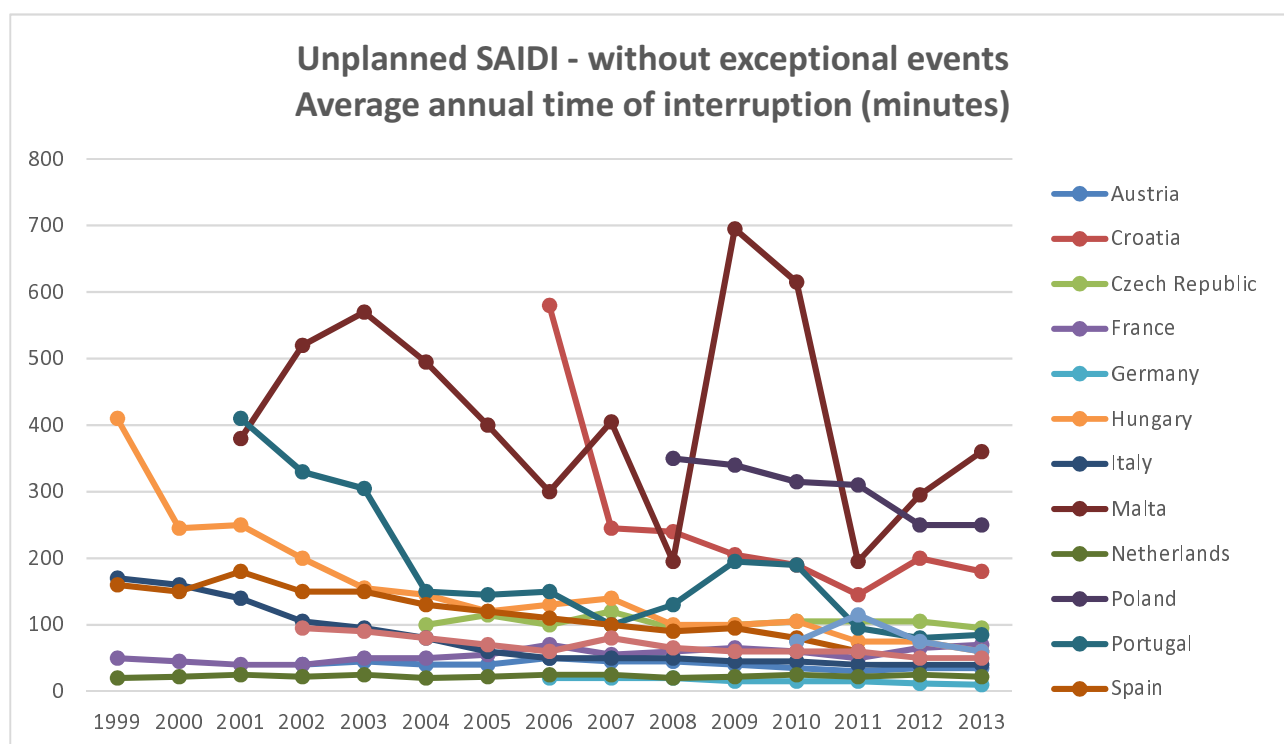
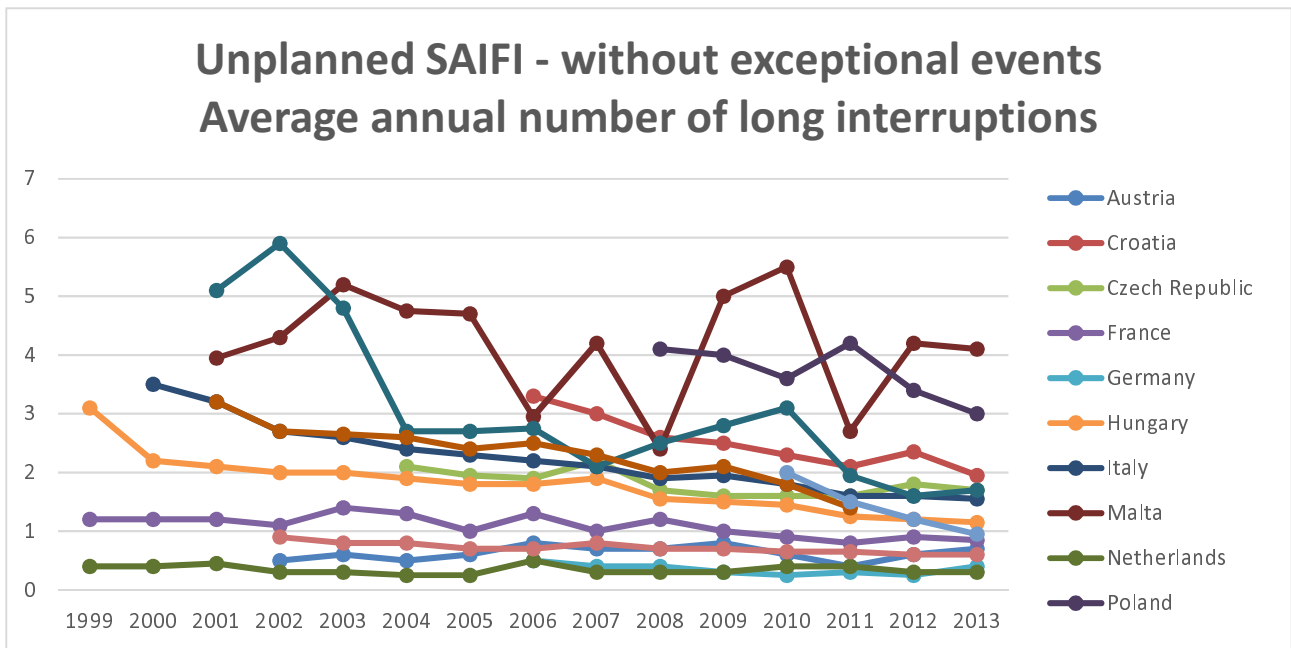
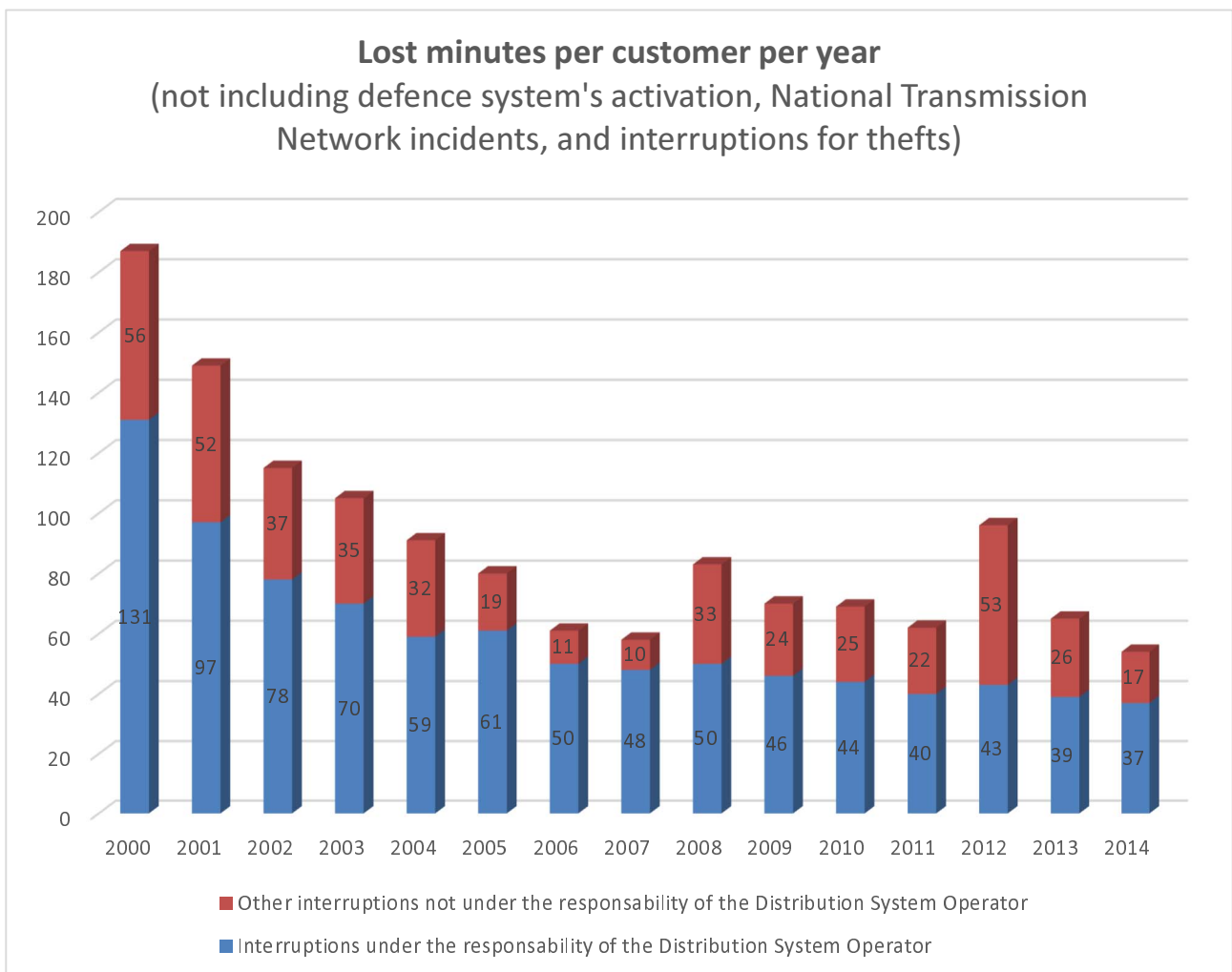

Figure A.1: Data on power grid availability for European countries



**Figure A.2: Data on power grid availability for European countries**

In a similar way, the following figures A.3, A.4 and A.5 give equivalent information for the Italian electrical LV power grid



**Figure A.3: Data on power grid availability for Italy**

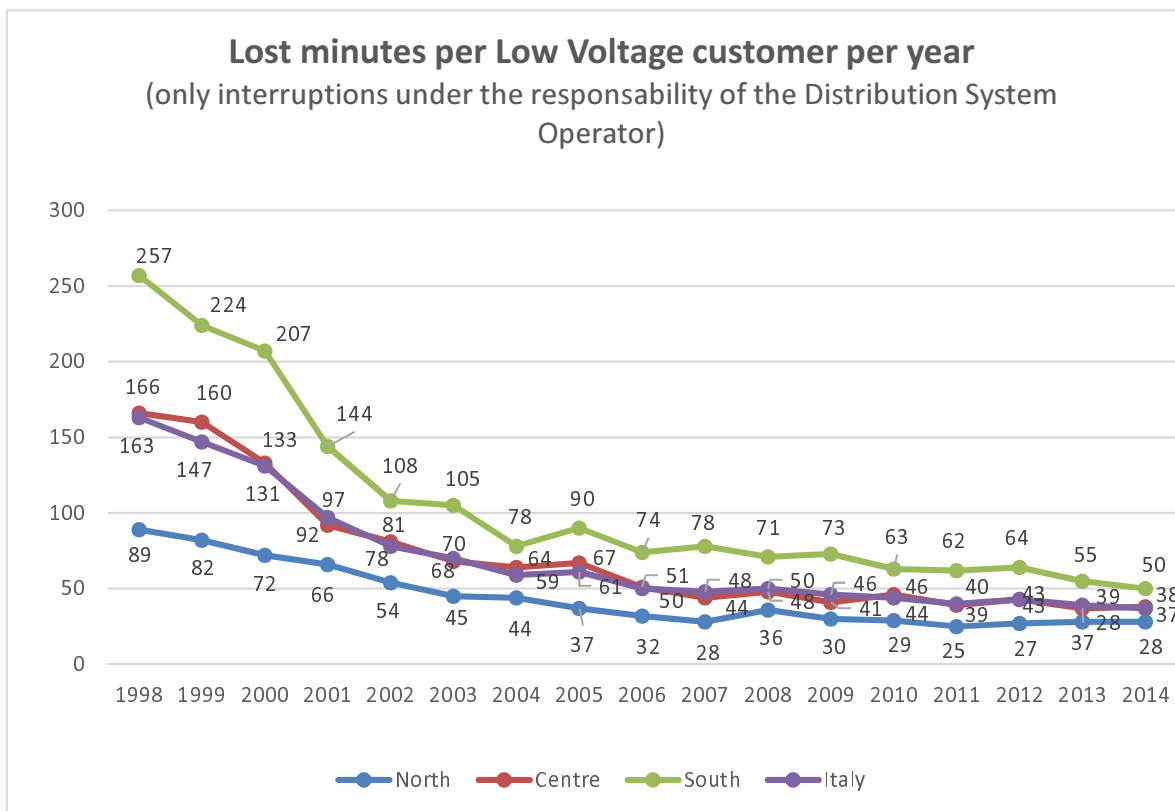

Figure A.4: Data on power grid availability for Italy

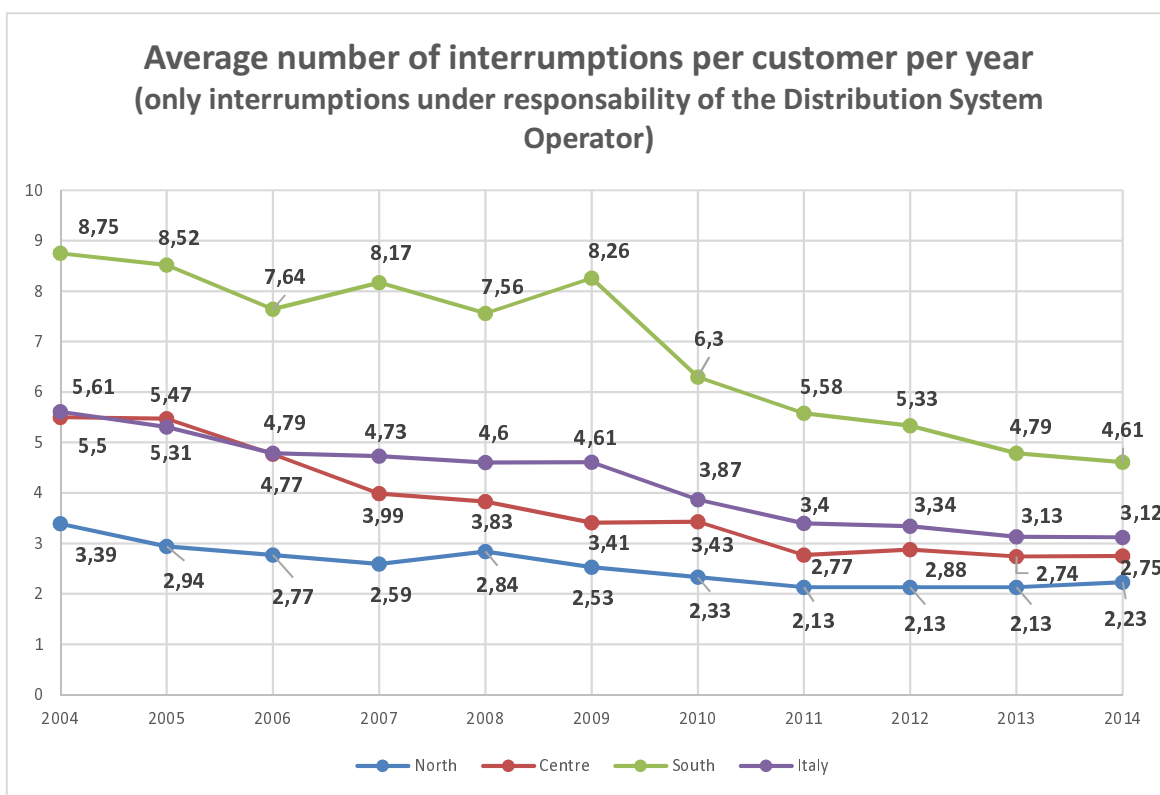

Figure A.5: Data on power grid availability for Italy

Figure A.6 shows the comparison of the total unavailability of classic PSTN and of the new NGA networks (FTTCab architecture, with or without adoption of mains' micro interruption coverage – up to 1 second - by supercapacitor adoption), as an example for the Italian network.

The total unavailability is, as a basis, primarily related to access network, Main Distribution Frame (MDF) in Central Office (CO) and network equipment reliability.

New fibre based NGA networks give, in general, a higher availability and reliability, with respect to traditional access network technologies.

In PSTN scenario no extra unavailability from public mains is taken into account (since PSTN has coverage of power outage through Central Office's batteries). In NGA network scenario, unavailability from public mains and related TE reboots has also to be taken into account.

The result of the analysis shows in figure A.6, that the adoption of a very short energy storage unit (supercapacitor for 1 second coverage of mains' micro interruptions) can significantly reduce the total unavailability of NGA network (with a sensible reduction due to TE reboots), giving a total level of unavailability lower than traditional PSTN from Central Office.

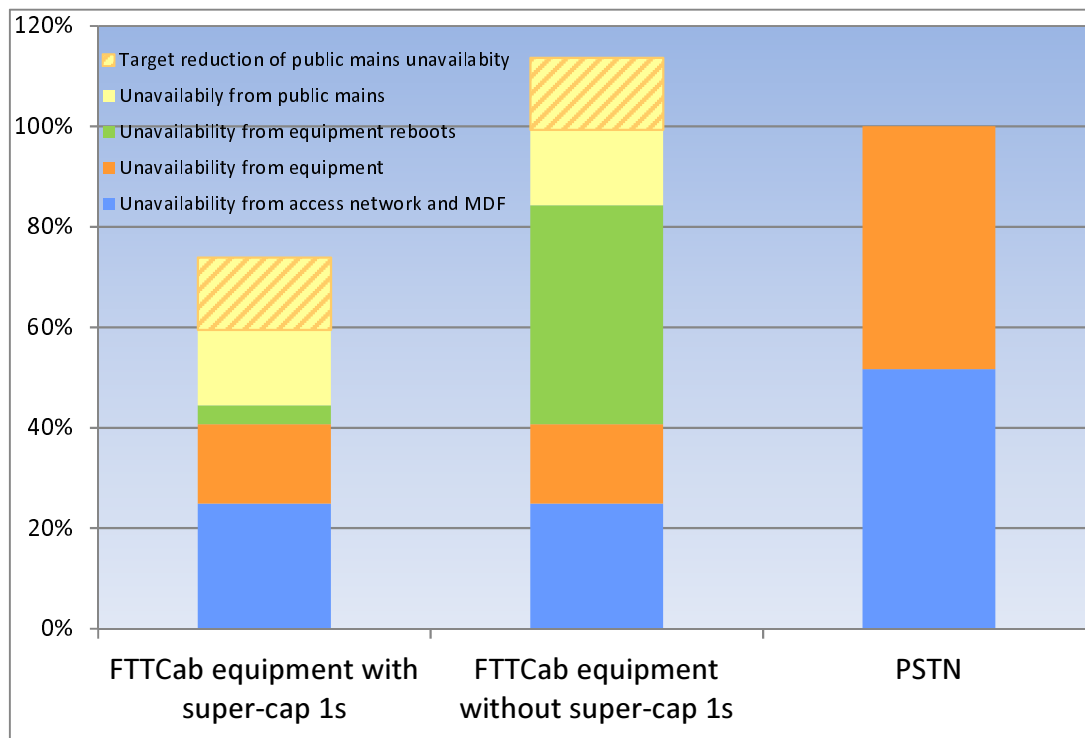

**Figure A.6: Unavailability of new NGA network (FTTCab) vs. classic PSTN**

So only global availability and reliability requirements should be considered and assured, taking into account also European regulatory requirement regarding network integrity and service availability, also for practical measures to comply with possible un-interruption requirement [i.9] and [i.18].

## Annex B (informative): Battery sizing

### B.0 General rules

In the case of innovative IP based access network technologies, including VoIP, the battery calculation applies only inside Telecom Centres and local exchanges, based on IP broadband network availability requirements as it was achieved with old generation PSTN access network equipment. When distributed access network equipment closer to the customer are used, the need of back-up and its type has to be defined case by case depending on national regulation, ICT unavailability requirements and which powering solution is chosen. For grid connected small system refer to clause 4 and annex A. When using remote powering there is in general no need of local power back-up.

The sizing of the battery is established at the maximum power discharge rate in order to allow the combined effects of:

- a) **its ageing:** the battery capacity should be adapted and sized to ensure the power discharge rate during the whole estimated service life of the battery (defined for the average operating temperature); in general that means that the battery autonomy should be obtained with 80 % of remaining capacity in the aged battery.
- b) **its environment conditions:** the battery capacity should be adapted and sized to ensure the discharge rate at the minimum operating temperature.

The maximum power discharge rate should be assessed based on equipment power consumption modelling, metrics and KPI (e.g. for type of equipment such as IP switching, routers, servers, radio access node or cellular base station, etc.). For example, for NGA broadband equipment (xDSL technology with VoIP services), the power consumption of the equipment can be calculated as stated in ETSI EN 303 215 [i.19], clause B.2 can be used as a rough model for all type of equipment when no better model is known.

In general the discharge rate corresponds to a constant power discharge as the Telecom/ICT equipment are equipped with DC/DC converters with approximatively constant efficiency over the battery discharge voltage range.

After a discharge at 20 °C defined by a constant discharge power  $P_{ICT}$  with a back-up time equal to the autonomy  $A_{bat}$ , the charge time of the battery at 80 % level should be shorter than 2 times the discharge time in order to allow a second discharge of 80 % with the same discharge rate than the first one.

The compliance with these criteria should be assessed using the data provided by the battery manufacturers. Sizing of the battery energy capacity  $EC_{bat}$  should be made at constant power. The power available at a given discharge duration can be found in manufacturers tables or sizing tool.  $EC_{bat}$  is in that case the energy capacity in Wh.

For example for 2 h autonomy of a Telecom/ICT consuming 784 W and with 1 V losses in the voltage distribution at 48 V i.e. about a total of 800 W, the backed-up power is 1 600 Wh it needs to take a battery giving this at 80 % of capacity at end of life, so  $EC_{bat} = 1\ 600\ Wh / 80\ \% = 2\ 000\ Wh$  and the discharge rate of the new battery is  $2\ 000 / 800 = 2,5$  hour. In practice, it will be achieved by 4 battery blocks of 12 V of 500 Wh capacity at 2 h rate up to an end of discharge voltage of 1,8 V per cell. For 24 cells as in 4 blocks of 12 V, the end of voltage is 43,2V on the battery poles, and so it allows with voltage drops in distribution to keep above the minimum voltage limit of -48 V Telecom/ICT equipment interface defined in ETSI EN 300 132-2 [2].

NOTE 1: For lead-acid technology, the higher is the voltage, the lower is the capacity, but the longer is lifetime. A trade-off is required to size correctly, e.g. for discharge time < 10 h, it is common to stop discharge at 1,8 V per cell.

NOTE 2: As some manufacturers are just providing coulombic capacity at constant current, it is possible to consider an average voltage at middle of discharge to calculate an equivalent constant power e.g. 1,9 V per cell at 2 hours discharge duration. In the previous example, that means 2 000 Wh at 2,5 h rate, needs more than 44 Ah at a mean voltage of 45,6 V.

## B.1 back-up power

For PSTN equipment and other ICT equipment when there is no better model in ETSI standard in respect to ICT equipment power consumption modelling, metrics and KPI, the power consumption P is established for the following conditions of power consumption:

$$P_{\text{back-up}} = P_{\text{core}} + n \cdot (P_{\text{idle}} + \varepsilon \cdot P_{\text{busy}}) + P_{\text{distr}}$$

where:

$P_{\text{back-up}}$  = Maximum power of the Telecom/ICT equipment and distribution losses used for defining the back-up energy capacity giving the required autonomy

$P_{\text{core}}$  = Maximum base power per PSTN equipment unit

n = Maximum number of subscribers which can be connected to the PSTN equipment unit

$P_{\text{idle}}$  = Power per equipped service module without traffic

$P_{\text{distr}}$  = Power losses in the electrical distribution (cable, interconnection, protective devices) between battery and ICT equipment interface. When not known, it is recommended to consider a mean 1 V losses at 48 V, which means about 2 % of P

$\varepsilon$  = 10 % (this is for example a traffic of 0,1 Erlang as explained in note 1)

$P_{\text{busy}}$  = Operating power consumption per subscriber off-hook line

NOTE 1: Selected value of ratio of off-hook subscribers. 0,1 Erlang is chosen, if no other required values are defined.

NOTE 2: The backed-up power is the output of the battery unit having taken into account the losses in the conversion stages of the system.

## B.2 Autonomy of the back-up

When a TE is designed with its own power unit including back-up function, the provider of the equipment has to define **the autonomy** (back-up time) and **the minimum service life** of the battery for the back-up power defined in the clause B.1 if no better model for the considered equipment can be found in an existing ETSI standard in respect to ICT energy consumption modelling, metrics and KPI.

During an upstream power failure, the battery should ensure the normal operation of the telecom/ICT equipment for the autonomy A considering a discharge at a constant power with value P defined in the table B.1.

**Table B.1: Back-up energy storage power and autonomy sizing**

Operating Conditions	P = Back-up Power	A, Autonomy in discharge with a constant power (=P)
Equipment consumption depending on traffic	$P_{\text{back-up}} = P_{\text{core}} + n \cdot (P_{\text{idle}} + \varepsilon \cdot P_{\text{busy}}) + P_{\text{distr}}$	A
Equipment consumption independent of traffic	$P_{\text{back-up}} = P_{\text{core}} + n \cdot P_{\text{idle}} + P_{\text{distr}}$	A
Equipment consumption independent of number of service units	$P_{\text{back-up}} = P_{\text{core}} + n \cdot \varepsilon \cdot P_{\text{busy}} + P_{\text{distr}}$	A
Consumption of an equipment in customer's home (n < 4)	a) $P_{\text{back-up}} = P_{\text{core}} + n \cdot P_{\text{idle}} + P_{\text{distr}}$ b) $P_{\text{back-up}} = P_{\text{core}} + n \cdot (P_{\text{idle}} + \varepsilon \cdot P_{\text{busy}}) + P_{\text{distr}}$	A <sub>1</sub> A <sub>2</sub>

NOTE: The purpose of this clause is to clarify the conditions for which the autonomy of the battery is defined. There is no intention of the present document to require any value of autonomy.

---

## B.3 Use of valve regulated lead acid battery

Valve regulated lead acid batteries should conform to EN 60896-2 [i.20].

In a floating mode operation, the battery can be kept charged at a voltage level corrected as a function of the temperature. The charging current is limited in accordance with the manufacturer's recommendations.

In a discharge mode operation, a disconnecting device can be used to isolate the battery from the load at the end of discharging when the value of low-voltage disconnection defined by the manufacturer is reached.

---

## B.4 Battery state of health test

A mechanism of periodic test of the battery can be provided. It proposes a criterion for a control of the ageing of the battery. The test is carried out automatically and establish whether the battery is capable of fulfilling its function or if the end of service life criterion is reached. The test ends with a report via the management system.

## Annex C (informative): Comparative reliability approach of remote powering versus local powering

This annex propose a reliability calculation based on Recommendation ITU-T L.1202 [i.25].

Two architectures are compared:

- **Local grid configuration** (figure 3 PM6, PM7): the access network cabinet is connected to local AC grid. It is equipped with -48 V Rectifier (R) / Battery (B). B is often a VRLA lead-acid battery with 1h autonomy. There is no redundancy of CB and B, and AC reliability is lower at the end of the grid.
- **Remote power configuration from telecom centre** (figure 1 PM3, 3a, 3b), and from cluster power site (figure 2, PM4, 5a, 5b, 5c, 5d): several access network cabinets are powered by RP lines as defined in clause 7. Each cabinet RPR is connected by a RP line to a RPU output interface in a centre. The centralized RPU is fed by a redundant rectifier/battery power system connected to grid with 3 hour autonomy and possibility to connect an emergency generator. In general the grid access can be carefully chosen not at the end of LV AC grid and sometime on HTA AC grid which improved a lot the AC grid reliability compared to remote cabinet local grid connection where this careful choice is not possible. The AC and DC distribution, rectifiers and batteries can be in redundant with much less over cost than in each remote cabinets and the battery test can be more elaborated. In addition, the maintenance is improved by more preventive alarms and shorter MTTR.

Example of reliability calculation and results are given in table C.1. Remote power solutions are found more reliable in all cases:

- 2,4 times more reliable with battery well managed;
- 5 to 10 times more reliable with battery not replaced;
- much lower probability of all sites down e.g. due to an AC grid common mode failure.

About the comparative reliability calculation, a very simplified reliability approach is as follows considering [i.25] clause III.2:

- By using approximation of exponential reliability function, giving a constant failure rate ( $\lambda$ ). This is allowing to use the easier to use Mean Time Between Failures ( $MTBF = 1/\lambda$ ). This can also be done for Mean Time To repair ( $MTTR = 1/\mu$ ), as used for AC grid reliability approach.
- With this approximation, it is possible to add serial bloc failure rates. As redundancy can lead to complicated calculations e.g. for rectifiers or the battery, the redundancy of electronic items can be simplified by considering that it is driven by the common mode failures such as the bus-bar short-circuits which can mean only multiplying by 10 the single equipment MTBF (e.g. 300 000 for the rectifier to 3 million hours). There should be a reliability calculation with grid MTBF without considering exceptional failure (e.g. due to a climatic crisis with a very long MTTR) and another reliability calculation including these exceptional failures to consider the autonomy and resilience of the system.
- A system is considered reparable when the MTTR of its components is short compared to the MTBF, for example for majority of electro mechanic and electronic components (modular AC/DC rectifier, circuit breakers), the failure detection alarm and the replacement are relatively short (from some hours to some days), and it does not affect so much the very long MTBF. For a battery where the loss of capacity failure rate accelerate at end of life and would require a discharge test to be detected, the failure rate is highly increased compared to average  $MTBF = 500\,000$  hours = 0,5 Mh. As usual life time is between 3 to 8 years depending on temperature, and the end of life accelerated loss of capacity of 1 to 0,3 year. It can be considered that the MTBF is increased by a factor 0,3 / 3 or 1 / 8, so about 10.

The basic reliability data of equipment (rectifier, battery, circuit breakers) are based on data proposed in appendix III of Recommendation ITU-T L.1202 [i.25] in Million hours for MTBF:

- AC and DC circuit breaker unit:  $MTBF = 0,2$ .
- internal cabinet distribution:  $MTBF > 1$ .



- rectifier unit: MTBF = 0,3.
- battery: MTBF = 0,5 before end of life.
- MTBF = 5 in the year of end of life (e.g. with no preventive replacement when ageing criteria of 80 % remaining is reached as defined in clause B.0).

Reliability data of the AC grid have been chosen based on European data of LV customer line interruption duration given in figure A.1 and frequency in figure A.2 with more detailed information on interruption frequency function of duration as observed on French AC grid:

- LV long interruption frequency in Europe roughly 3 yearly interruption classes (0,3 - 1, 1 - 2, 2 - 4)
- LV long interruption duration in Europe roughly 3 yearly duration classes in hours (< 0,5, 0,5 - 2 h, 2 - 4 h)

Example of France grid data:

- LV short interruption, MTTR < 15 min:  $\lambda$  average =  $5,7 \cdot 10^{-4} \text{ h}^{-1}$  (dispersion 2 to 10)
- LV long interruption, MTTR < 1 h:  $\lambda$  average =  $1,7 \cdot 10^{-4} \text{ h}^{-1}$  (dispersion 0,5 to 2)
- LV long interruption, MTTR > 3 h: 4,80 % of long interruptions
- HVA long interruption, MTTR < 1 h:  $\lambda$  average =  $0,58 \cdot 10^{-4} \text{ h}^{-1}$
- HVA long interruption, MTTR > 3 h: 3,2 % of long interruptions

A rough sensibility calculation is carried out with some reliability and repair parameters simulated by multiplying by 2 and dividing by 2 the different reliability parameters (MTBF, grid MTTR):

- equipment good and bad environmental and operational conditions;
- good AC grid / bad AC grid;
- for non-redundant battery, the MTBF considered constant is only the stabilized failure rate  $\lambda$  after early life failure and before end of life. At start and end of life, the failure rate is much higher. For example for a lead-acid battery bloc it can be multiplied by 10 in the first year and in the year of the predicted end of life. In order to take this important risk into account two failure rate are considered for case (1).

About the error assessment, the result is valid only if the park and time of observation is sufficient to estimate a reasonable error on the failure rate as illustrated in the following examples:

- if 50 failures per year are observed on a set of 100 items of equipment (i.e. about 1 Million hour of observation), MTBF = 20 000 h and error =  $1 / 50 = 2 \%$ ;
- if only 2 failures per year are observed, MTBF = 500 000 h but the error range is huge: MTBF = 300 000 h for 3 failures and MTBF = 1 Million h for 1 failures, so there may be a factor 3 in the MTBF.

The assessment of ICT equipment unavailability is not proposed in this first approach as it is much more complex. It depends on equipment MTTR is 0,5 to 4 h, and on failure type, alarm and access delays. For example, there is no interruption in case of failure of a redundant rectifier or in case of battery failure if there is no grid interruption. About battery MTTR, there is a detailed approach in appendix III.2 of Recommendation ITU-T L.1202 [i.25] taking into account the test period.

**Table C.1: Example of compared reliability assessment between remote powered TE and grid connected TE**

End LV AC line	Equipment unit MTBF (in Mh)	All failure rate in (.10-6/h)			Selected LV or HVA line	All failure rate in (.10-6/h)			
		<15mn	1h	>3h		1h	>3h		
AC grid Interruption class		<15mn	1h	>3h		1h	>3h		
AC grid failure rate		570	171	8		131	4		
unavailability = interruption probability		0,014%	0,013%	0,0025%		0,013%	0,000013		
Panne n arrivées EdF		10%	50%	100%		100%	100%		
<b>Power Equipment reliability</b>									
Single circuit breaker (CB)	0,2	5	5	5	Redundant CB	0,5	0,5		
n+1 rectifiers (10 times better than single)	0,3	0,3	0,3	0,3	n+2 rectifiers	0,3	0,3		
Single cabinet 1h battery and CB before end of life (EoL) probability of autonomy >3h = 1	0,5	6,2	6,2	1000000	1+1 battery of 3h autonomy	1,2	1,2		
Battery not replaced at EoL(probability of autonomy < 1h = 1)		17	1000000	1000000	1 of the Battery not replaced (autonomy 1 to 3h)	17	1000000		
					RPR, RPU, CB and RP line	12	12		
<b>1 site failure</b>					<b>1 site failure rate</b>			<b>worse value</b>	<b>reliability gain</b>
cabinet battery replaced before EoL		5	5	30	RPU site battery ok	13	13	<b>13</b>	<b>2,4</b>
not replaced before EoL		5	134	30	RPU site battery not replaced	13	25	<b>25</b>	<b>5,3</b>
					emergency power option		13	<b>13</b>	<b>10,7</b>
<b>1 site of n in failure</b>		10	10	10	<b>1 site of n : failure rate</b>	10	10		
cabinet battery replaced before EoL		53	53	300	RPU site battery ok	125	125	<b>125</b>	<b>2,4</b>
not replaced before EoL		53	1337	300	RPU site battery not replaced	125	251	<b>251</b>	<b>5,3</b>
<b>All n sites off</b>					<b>All n sites off</b>				
cabinet battery replaced before EoL		0	0	25	RPU site battery ok	1	1	<b>1</b>	<b>29,6</b>
only 50% cabinet battery replaced before EoL		0	32	25	RPU site battery not replaced	1	13	<b>13</b>	<b>2,4</b>
					si GE mobile		1	<b>1</b>	<b>38,4</b>

---

## Annex D (informative): Bibliography

"Application Report SLVA694: Using Hot-Swap Controllers for Reverse Powering FTTdp", Texas instrument, April 2015.

"Reverse Powering, its Benefits and Constraints", Daniel Feldman -VP Business Development, Microsemi, 2014.

---

## History

<b>Document history</b>		
V1.1.1	January 2002	Publication
V2.1.1	August 2014	Publication
V2.1.30	October 2020	EN Approval Procedure AP 20210128: 2020-10-30 to 2021-01-28