

ETSI EN 302 099 V2.1.1 (2014-08)



**Environmental Engineering (EE);
Powering of equipment in access network**

Reference

REN/EE-02043

Keywords

access, network, power supply, remote

ETSI

650 Route des Lucioles
F-06921 Sophia Antipolis Cedex - FRANCE

Tel.: +33 4 92 94 42 00 Fax: +33 4 93 65 47 16

Siret N° 348 623 562 00017 - NAF 742 C
Association à but non lucratif enregistrée à la
Sous-Préfecture de Grasse (06) N° 7803/88

Important notice

The present document can be downloaded from:

<http://www.etsi.org>

The present document may be made available in electronic versions and/or in print. The content of any electronic and/or print versions of the present document shall not be modified without the prior written authorization of ETSI. In case of any existing or perceived difference in contents between such versions and/or in print, the only prevailing document is the print of the Portable Document Format (PDF) version kept on a specific network drive within ETSI Secretariat.

Users of the present document should be aware that the document may be subject to revision or change of status. Information on the current status of this and other ETSI documents is available at

<http://portal.etsi.org/tb/status/status.asp>

If you find errors in the present document, please send your comment to one of the following services:

http://portal.etsi.org/chaicor/ETSI_support.asp

Copyright Notification

No part may be reproduced or utilized in any form or by any means, electronic or mechanical, including photocopying and microfilm except as authorized by written permission of ETSI.

The content of the PDF version shall not be modified without the written authorization of ETSI.

The copyright and the foregoing restriction extend to reproduction in all media.

© European Telecommunications Standards Institute 2014.

All rights reserved.

DECT™, **PLUGTESTS™**, **UMTS™** and the ETSI logo are Trade Marks of ETSI registered for the benefit of its Members. **3GPP™** and **LTE™** are Trade Marks of ETSI registered for the benefit of its Members and of the 3GPP Organizational Partners.

GSM® and the GSM logo are Trade Marks registered and owned by the GSM Association.

Contents

Intellectual Property Rights	5
Foreword.....	5
Modal verbs terminology.....	5
1 Scope	6
2 References	6
2.1 Normative references	6
2.2 Informative references.....	7
3 Definitions and abbreviations.....	8
3.1 Definitions.....	8
3.2 Abbreviations	9
4 Powering configurations.....	9
4.1 Remote powering	11
4.1.1 Centralized powering.....	11
4.1.2 Cluster powering.....	11
4.2 Local powering.....	12
4.2.1 TE of access network, common to several customers.....	12
4.2.2 TE of access network, at customer's home	13
4.2.3 TE in access network reverse powered from customer home	14
5 Effect of the technologies on the powering strategy	15
5.1 Powering strategy of family 1: metallic links.....	16
5.2 Powering strategy of family 2: non-metallic links	16
6 Requirements for local powering	17
6.1 TE including the power plant	17
6.2 TE powered by a dc voltage nominal -48 V local power unit	17
6.3 TE powered by a LPU with a dc voltage other than -48 V.....	17
6.4 TE powered by a nominal ac voltage of 230 V, 50 Hz local power unit.....	17
7 Requirements for remote powering.....	17
7.1 Input of the Remote Power Unit.....	17
7.2 Output of the Remote Power Unit.....	18
7.3 Input characteristics of remote powered receiver in the voltage mode	18
7.4 Input characteristics of remote powered receiver in the current mode	18
8 Power back-up.....	18
9 Power management	18
10 Safety, EMC, protection.....	20
10.1 Product Safety	20
10.2 EMC	21
10.3 Protection/resistibility	21
10.4 Bonding and earthing	21
11 Environmental conditions.....	22
Annex A (normative): Battery sizing.....	23
A.1 Back-up power for telephone service.....	23
A.2 Autonomy of the back-up.....	23
A.3 Use of valve regulated lead acid battery.....	24
A.4 End of service life of battery	24

Annex B (informative): Bibliography.....25
History26

Intellectual Property Rights

IPRs essential or potentially essential to the present document may have been declared to ETSI. The information pertaining to these essential IPRs, if any, is publicly available for **ETSI members and non-members**, and can be found in ETSI SR 000 314: "*Intellectual Property Rights (IPRs); Essential, or potentially Essential, IPRs notified to ETSI in respect of ETSI standards*", which is available from the ETSI Secretariat. Latest updates are available on the ETSI Web server (<http://ipr.etsi.org>).

Pursuant to the ETSI IPR Policy, no investigation, including IPR searches, has been carried out by ETSI. No guarantee can be given as to the existence of other IPRs not referenced in ETSI SR 000 314 (or the updates on the ETSI Web server) which are, or may be, or may become, essential to the present document.

Foreword

This European Standard (EN) has been produced by ETSI Technical Committee Environmental Engineering (EE).

National transposition dates	
Date of adoption of this EN:	18 August 2014
Date of latest announcement of this EN (doa):	30 November 2014
Date of latest publication of new National Standard or endorsement of this EN (dop/e):	31 May 2015
Date of withdrawal of any conflicting National Standard (dow):	31 May 2015

Modal verbs terminology

In the present document "**shall**", "**shall not**", "**should**", "**should not**", "**may**", "**may not**", "**need**", "**need not**", "**will**", "**will not**", "**can**" and "**cannot**" are to be interpreted as described in clause 3.2 of the [ETSI Drafting Rules](#) (Verbal forms for the expression of provisions).

"**must**" and "**must not**" are **NOT** allowed in ETSI deliverables except when used in direct citation.

1 Scope

The present document describes the principles for powering of Telecommunications Equipment (TE) in access networks and contains requirements for the powering systems, laying down:

- the characteristics of the input and output interfaces of the power units;
- the power back-up conditions for TE including a power unit;
- the management data, necessary to guarantee the availability of the service and to ensure the maintenance of the power units.

The present document takes into account the characteristics of access network equipment for which the limits of responsibility in the installation or design of the power plants are very different than for equipment of telecom centre: it goes from "complete integration of the power plant in the TE" to "remote power feeding from a distant power plant".

The present document applies to the powering of all equipment of the access network (copper, fibre or radio networks) located outside telecommunications centres. The access network is defined as the part of the telecommunications network, which comprises the customer terminal installation and the first exchange (switching unit). The customer terminal and the switching unit are excluded from the application field of the present document.

The present document describes different configurations of powering the TE:

- Local power supply for TE.
- Remote Feeding to TE from centre through copper access pair.
- Cluster Power supply feeding power for a cluster of TE.
- Back feeding or Reverse Powering architecture that can supply power to Access Network Units such as ONU or ONT or remote DSL unit from the customer premises through its final distribution access copper pair.

2 References

References are either specific (identified by date of publication and/or edition number or version number) or non-specific. For specific references, only the cited version applies. For non-specific references, the latest version of the reference document (including any amendments) applies.

Referenced documents which are not found to be publicly available in the expected location might be found at <http://docbox.etsi.org/Reference>.

NOTE: While any hyperlinks included in this clause were valid at the time of publication ETSI cannot guarantee their long term validity.

2.1 Normative references

The following referenced documents are necessary for the application of the present document.

- [1] ETSI ETS 300 132-1: "Equipment Engineering (EE); Power supply interface at the input to telecommunications equipment; Part 1: Operated by alternating current (ac) derived from direct current (dc) sources".
- [2] ETSI EN 300 132-2: "Environmental Engineering (EE); Power supply interface at the input to telecommunications and datacom (ICT) equipment; Part 2: Operated by -48 V direct current (dc)".
- [3] CENELEC EN 60950-1: "Information technology equipment - Safety - Part 1: General requirements".
- [4] IEC 60950-21: "Safety of information technology equipment - Part 21: Remote power feeding".

- [5] CENELEC/IEC EN 60038: "CENELEC/IEC standard voltages".
- [6] CENELEC EN 60664-1: "Insulation coordination for equipment within low-voltage systems - Part 1: Principles, requirements and tests".
- [7] CENELEC EN 50310: "Application of equipotential bonding and earthing in buildings with information technology equipment".
- [8] CENELEC EN 60896-2: "Stationary lead-acid batteries - General requirements and methods of test - Part 2: Valve regulated types".
- [9] ETSI EN 300 253: "Environmental Engineering (EE); Earthing and bonding of telecommunication equipment in telecommunication centres".
- [10] Recommendation ITU-T K.35: "Bonding configurations and earthing at remote electronic sites".
- [11] CENELEC TR 62102: "Electrical safety - Classification of interfaces for equipment to be connected to information and communications technology networks".
- [12] Recommendation ITU-T K.45: "Resistibility of telecommunication equipment installed in the access and trunk networks to overvoltages and overcurrents".
- [13] ETSI ES 203 215: "Environmental Engineering (EE); Measurement Methods and Limits for Power Consumption in Broadband Telecommunication Networks Equipment".
- [14] ETSI EN 300 132-3-1: "Environmental Engineering (EE); Power supply interface at the input to telecommunications and datacom (ICT) equipment; Part 3: Operated by rectified current source, alternating current source or direct current source up to 400 V; Sub-part 1: Direct current source up to 400 V".
- [15] ETSI ES 202 336-1: "Environmental Engineering (EE); Monitoring and Control Interface for Infrastructure Equipment (Power, Cooling and Building Environment Systems used in Telecommunication Networks); Part 1: Generic Interface".

2.2 Informative references

The following referenced documents are not necessary for the application of the present document but they assist the user with regard to a particular subject area.

- [i.1] ETSI EN 300 019-1-1: "Environmental Engineering (EE); Environmental conditions and environmental tests for telecommunications equipment; Part 1-1: Classification of environmental conditions; Storage".
- [i.2] ETSI EN 300 019-1-3: "Environmental Engineering (EE); Environmental conditions and environmental tests for telecommunications equipment; Part 1-3: Classification of environmental conditions; Stationary use at weatherprotected locations".
- [i.3] ETSI EN 300 019-1-4: "Environmental Engineering (EE); Environmental conditions and environmental tests for telecommunications equipment; Part 1-4: Classification of environmental conditions; Stationary use at non-weatherprotected locations".
- [i.4] ETSI EN 300 019-1-8: "Environmental Engineering (EE); Environmental conditions and environmental tests for telecommunications equipment; Part 1-8: Classification of environmental conditions; Stationary use at underground locations".
- [i.5] ETSI TR 102 629: "Access, Terminals, Transmission and Multiplexing (ATTM); Reverse Power Feed for Remote Nodes".
- [i.6] ETSI EN 301 605: "Environmental Engineering (EE); Earthing and bonding of 400 VDC data and telecom (ICT) equipment".
- [i.7] ETSI TR 102 614: "Environmental Engineering (EE); Reverse powering of access network unit by end-user equipment: A4 interface".

- [i.8] CENELEC HD 60364-1: "Low-voltage electrical installations - Part 1: Fundamental principles, assessment of general characteristics, definitions".
- [i.9] ETSI EN 302 999: "Safety; Remote Power Feeding Installations; Safety requirements for the erection and operation of information technology installations with remote power feeding".

3 Definitions and abbreviations

3.1 Definitions

For the purposes of the present document the following terms and definitions apply:

access network: part of a telecommunications network between the customer terminal installation and the first switching unit

backfeeding or reverse powering: powering architecture that can supply power to access network units from the customer through its final distribution access copper pair

NOTE: Access network units may be ONU, ONT or remote DSL units.

centralized powering: remote powering in which the remote feeding source is located in a telecommunications centre

cluster powering: remote powering of a cluster of equipment (1 to n items of equipment), in which the remote feeding source is located outside a telecommunications centre

distant power receiver: power equipment electrically connected to a Remote Power Unit

NOTE: Its function is to supply telecommunications equipment situated at the same location. It may be combined with the item of telecommunications equipment itself.

hazardous voltage: See EN 60950-1 [3].

Local Power Unit (LPU): power supply equipment whose function is to supply a telecommunication equipment situated at the same location

NOTE: It is generally locally connected to the mains and provides dc or ac voltage output to feed telecommunication equipment.

local powering: powering principle of a telecommunications equipment by a (dedicated) power unit implemented in the same location

primary circuit: See EN 60950-1 [3].

Remote Feeding Telecommunication (RFT) circuit: secondary circuit within the equipment, intended to supply or receive dc power via a telecommunication network at voltages equal to or exceeding the limits for TNV circuits, and on which overvoltages from telecommunication networks are possible

Remote Power Unit (RPU): power unit, connected to the mains or from a centralized power plant, which supplies distant telecommunications equipment

remote powering: power feeding of a telecommunications equipment by a remote power circuit

NOTE: Such a circuit consists of a remote power unit, distribution wiring, and fed receivers.

RFT-C circuit: RFT circuit which is so designed and protected that under normal operating conditions and single fault conditions the currents in the circuit do not exceed defined values

RFT-V circuit: RFT circuit which is so designed and protected that under normal operating conditions and single fault conditions the voltages are limited and the accessible area of contact is limited

secondary circuit: See EN 60950-1 [3].

SELV circuit: See EN 60950-1 [3].

TN-C: See CENELEC HD 60364-1 [i.8].

TN-S: See CENELEC HD 60364-1 [i.8].

TNV circuit: See EN 60950-1 [3].

TT: See CENELEC HD 60364-1 [i.8].

3.2 Abbreviations

For the purposes of the present document, the following abbreviations apply:

ac	alternating current
AN	Access Node
ANU	Access Network Unit
CH	Customer's Home
CPE	Customer's Premises Equipment
dc	direct current
DC/DC	Direct Current/Direct Current
DSL	Digital Subscriber Line
EMC	ElectroMagnetic Compatibility
FTTB	Fibre To The Building
FTTC	Fibre To The Curb
FTTCab	Fibre To The Cabinet
FTTDp	Fibre To The Distribution point
FTTH	Fibre To The Home
HD	Harmonization Document
ICT	Information & Communication Technology
IEC	International Electrical Committee
ISDN	Integrated Services Digital Network
IT	Information Technology
ITU-T	International Telecommunication Union - Sector Telecommunication (T)
LED	Light Emitting Diode
LPU	Local Power Unit
ONT	Optical Network Termination
ONU	Optical Network Unit
P	Power
PG	Power Gathering
PW	Power Way
RFT	Remote Feeding Telecommunication
RFT-C	Remote Feeding Telecommunication-Current
RFT-V	Remote Feeding Telecommunication-Voltage
RPU	Remote Power Unit
S	Signal
S/P _{filter}	filter separating signal S and power P
SELV	Safety Extra Low Voltage
TC	Telecommunication's Centre
TE	Telecom Equipment
TNV	Telecommunication Network Voltage
UPS	Uninterruptible Power Supply

4 Powering configurations

The main characteristic feature of the different powering architectures of access network equipment is the location of the following two functions:

- the point of connection to the mains; and
- the place of power back-up.

The total network can be divided in three main parts:

- 1) the Telecommunication Centre (TC);
- 2) the field (the undefined area between the Telecom Centre and the Customer's Home);
- 3) the Customer's Home (CH).

Powering architectures

Equipment of access networks can be powered remotely from a telecommunications centre (centralized powering) or from a power supply node (cluster powering), or locally from the mains (local powering). Inside these three main powering architectures, several configurations of powering are used. They are summarized in the clauses 4.1 to 4.2 and in the figures 1, 2 and 3 by the acronyms PW1 to PW 10 (for powering).

Power back-up

For the telephone service, which needs to provide an available service even in the case of a mains outage, a power back-up unit is located either in the remote power source or in the equipment powered. The clauses 4.1 to 4.2 detail the different installation configurations.

Location of the Telecom Equipment (TE)

On the figures 1, 2 and 3 of the following clauses, the TE in access network is schematically represented in the field. These figures mean that the TE can be implemented in different types of locations:

- in a customer's office;
- in a building, public or private;
- in an indoor cabinet;
- in a street cabinet;
- on a pole cabinet;
- in a telecommunications manhole, etc.

The TE provides services for several customers or for one professional customer.

On figure 3, the TE can be located at customer's home and provides services for only one private customer.

Power interfaces

Six power-feeding interfaces are mentioned in the following clauses: They are as follows:

I_0 = Power interface between a -48 V/-60 V power plant and the fed equipment in a telecom centre. It fits with the interface "A" according to EN 300 132-2 [2].

I_1 = Power interface between the public mains (commercial ac) and the fed equipment. It shall comply with the voltage defined in EN 60038 [5].

I_2 = Power interface at the output of a remote power source.

I_3 = Power interface at the input of a distant power receiver interface, in remote powering.

I_4 = Power interface between a local power unit and the fed equipment, in local powering. It fits with the interface "A" according to EN 300 132-2 [2] or with the interface defined in clauses 6.2 to 6.4.

I_5 = Power interface between the equipment in a telecom centre and one of the following:

- i) the public mains (commercial ac); or
- ii) emergency power (UPS, diesel generator); or
- iii) interface "A" that shall comply with ETS 300 132-1 [1]; or

iv) interface "A3" that shall comply with EN 300 132-3-1 [14]. Nominal AC voltage shall comply with the voltage defined in EN 60038 [5].

I_6 = Power Interface from the customer. When using the telecom pair to transmit power, the voltage is 60 V DC maximum and peaks are limited according to TR 102 614 [i.7] and EN 60950-1 [3]. Under specific conditions ensuring proper operation, safety and reliability for POTS or DSL lines, a maximum of 120 V DC voltage option is possible from point of connexion outside of the customer premises (same limits as for ISDN voltage).

4.1 Remote powering

4.1.1 Centralized powering

The different power supply configurations are detailed in figure 1. The output of the power source is defined at interface I_2 . It comes from a TE (PW1a) or from a specific remote power unit (RPU in PW1b). Interface I_0 corresponds to the input of the RPU. The remote power unit consists of protection and distribution devices and, possibly, power conversion equipment. Interface I_5 corresponds to Interface I_1 and is located in the telecommunication centre.

In some cases, the TE of the access network may be equipped with a battery providing additional power in periods of heavy traffic (PW3). This battery is recharged by the remote power supply during periods of light traffic.

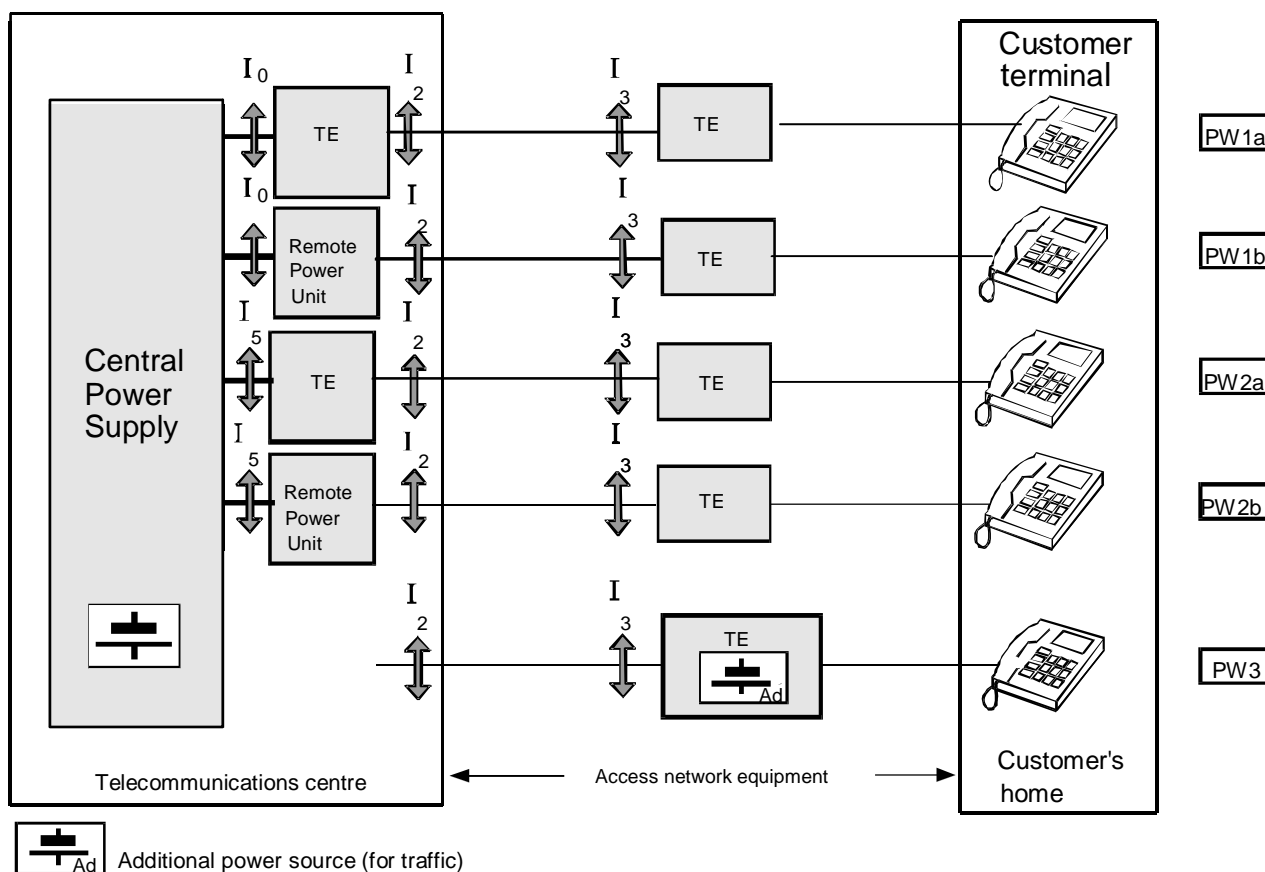

Figure 1: Centralized powering

4.1.2 Cluster powering

The different possible power supply configurations are detailed in figure 2. The remote power source, called Remote Power Unit (RPU), serves a group of distant telecommunications equipment, from 1 to n. The RPU is installed in a location (building, outdoor cabinet, manhole, etc.) which is distinct from the TE's building, cabinet or manhole. The telephone service is backed up by batteries located either at the remote power unit (remote powering with back-up at source, PW4) or in the telecommunications equipment (remote powering with local back-up, PW5).

The voltage on I_2 and I_3 is limited as defined in table 3 of clause 10.1.

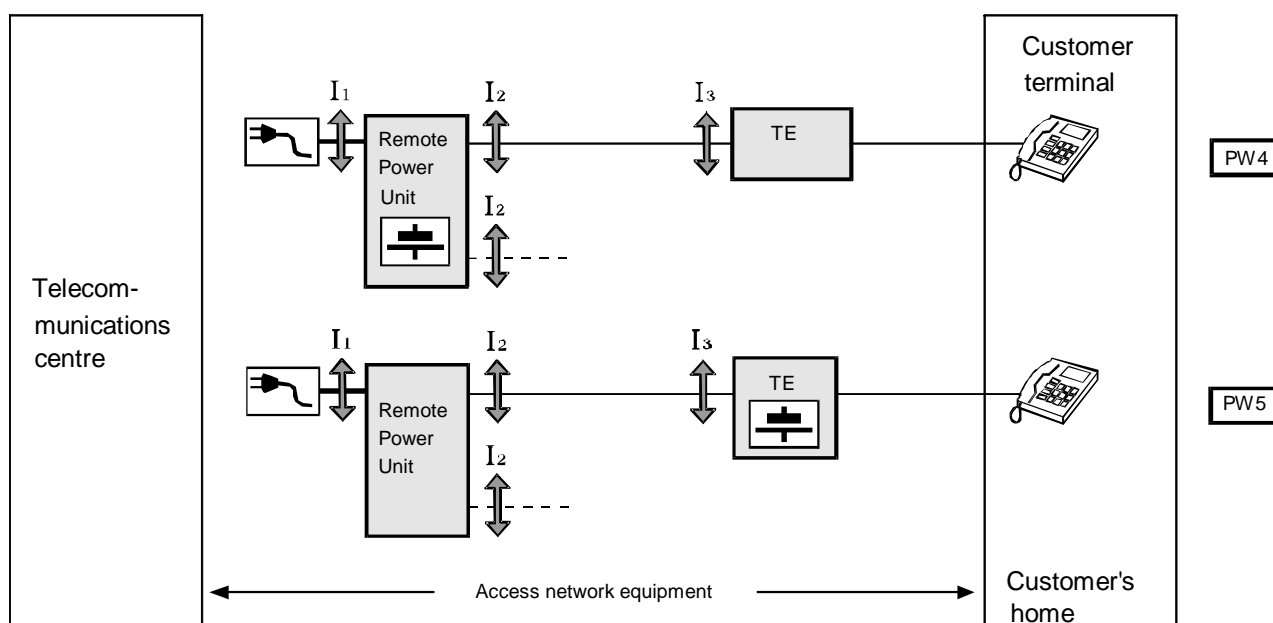

Figure 2: Cluster powering

4.2 Local powering

4.2.1 TE of access network, common to several customers

The different possible local power supply configurations are detailed in figure 3. They are the following two basic types:

- The telecommunications equipment is powered (Interface I_4) through a Local Power Unit (LPU in PW6) providing the functions of protection, power conversion and back-up of telephone service. It is either housed in the telecommunications equipment rack or installed in an independent mounting, but always in the same building or location as the TE.
- The telecommunications equipment is powered directly from the mains at Interface I_1 (PW7). It includes protection devices, power conversion equipment and back-up blocks for telephone service.

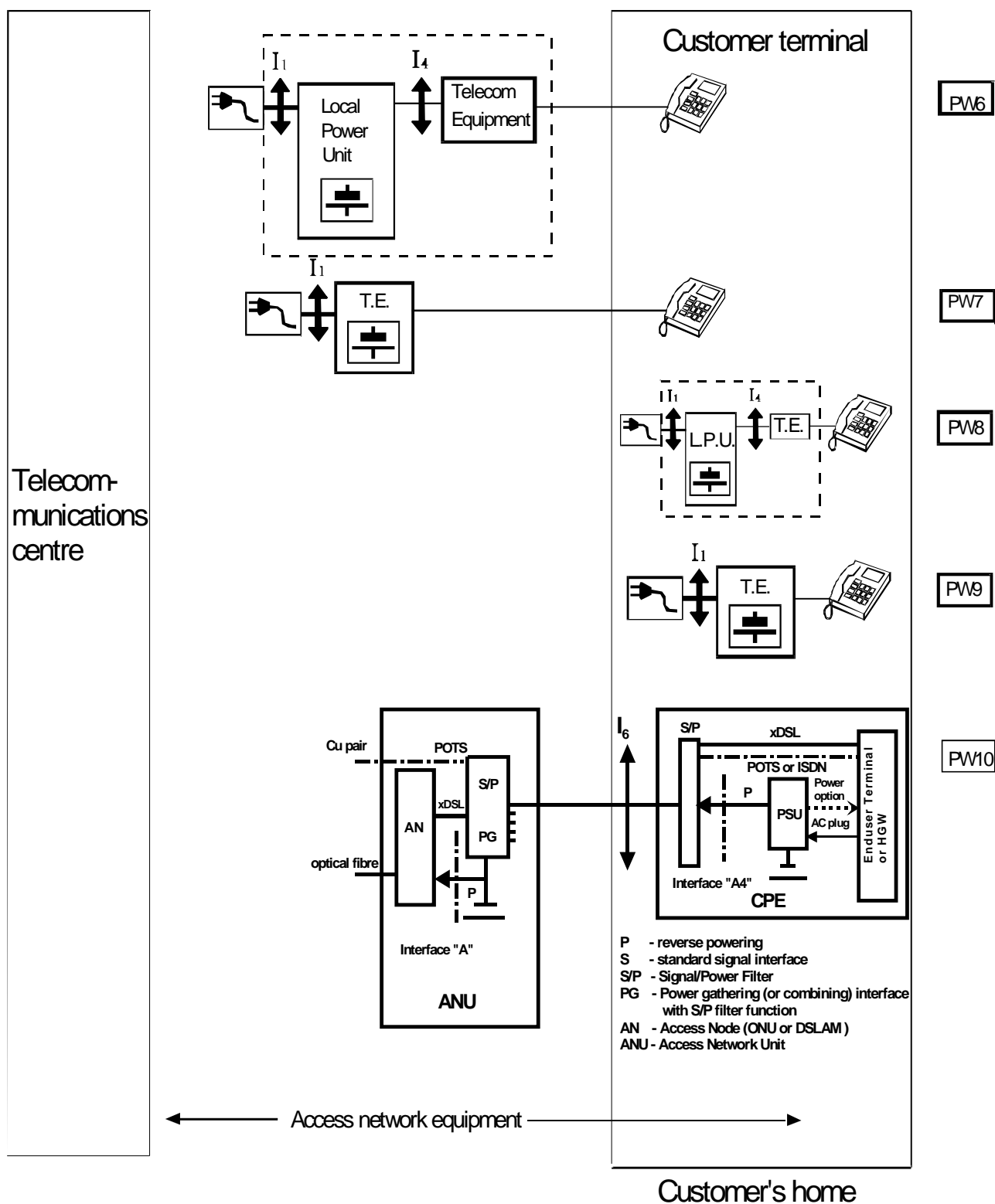

Figure 3: Local powering configurations

4.2.2 TE of access network, at customer's home

The TE is located in a customer's home and provides services for a single private customer. Two types of power feeding are defined in local powering architecture:

- the telecommunications equipment is powered (interface I_4) through a Local Power Unit (PW8) which may additionally provide backup;

- the telecommunications equipment usually provides back-up for telephone service when supplied by the mains or by UPS (PW9).

4.2.3 TE in access network reverse powered from customer home

The ANU, ONU or remote DSL unit or any kind of access telecom equipment between a telecom centre and the customer premises and is generally located in FTTB, FTTP or FTTC cabinet or underground chamber or man-hole. The telecom access node equipment is common to N customers (x=Building, Curb, Node, etc.), and is generally powered through 48 V interface A as defined in EN 300 132-2 [2] by a power gathering interface PG receiving pairs from customer through a splitter separating signal S and power P (S/P_{filter}).

NOTE 1: The determination of the need of a S/Pfilter splitter is out of the scope of the present document. It is used to avoid direct current on some CPE not accepting DC at input or for avoiding conflict with POTS interface and attenuation of telecom signal by DC power supply output impedance.

In the FTTP configuration one customer feeds one ANU with one or more ports by reverse powering either on a copper twisted pair or on a coaxial cable.

The power on a telecommunication network copper twisted pair shall be compliant under any load condition to safety requirements in EN 60950-1 [3].

For telecom network respecting all basic safety conditions of EN 60950-1 [3], the power source shall be limited to 15 W. The reverse powering voltage is at maximum -60 V DC (PW 10). Details on the choice of the voltage limit for ensuring safety in customer premises is given in TR 102 614 [i.7].

The maximum current is 250 mA at -60 V DC and below which means that the S/P_{filter} should be dimensioned for the maximum current of 250 mA.

If a lower limit of voltage is used, the current would be limited by the maximum power of 15 W, e.g. if this voltage value is 50V, the current should be not greater than 300 mA.

For power source higher than 15 W the connected equipment and the network shall fulfil additional safety requirements defined in EN 60950-1 [3].

For compatibility reason, the same interface is used on an option with coaxial cable in place of a twisted pair. The appropriate copper section and interconnection and connectors shall be used for low energy loss and safety. In the case of access network for powering of the ICT equipment with 60V reverse powering, the powered equipment shall be capable of accepting input voltages not exceeding 72 V.

This limit of power gives a limit for the energy cost per user and the power should be fairly supported by customer by a method to split almost equally the power between reverse powering lines (TR 102 614 [i.7] and TR 102 629 [i.5]).

NOTE 2: The overlay of reverse powering on POTS pair between customer and the ANU is possible. There should be circuitry to avoid a power collision between the phone remote powering and low frequency signals with the reverse powering (TR 102 614 [i.7]).

NOTE 3: There could be a lower voltage than 60 V used to protect existing POTS CPE, in some nations.

NOTE 4: The reverse powering should always be on, even when using DSL standby low power mode, to be independent from DSL line status modes (L0, L2, L3 modes).

NOTE 5: When there is a requirement of more power or longer distance for reverse powering, that should fulfill, the TNV 3 voltage limit lower than 120 V DC and the current or power consumption limitation for twisted copper pairs according of EN 60950-1 [3]. It is possible to increase the voltage to the maximum limit for TNV 3 120 V DC defined in EN 60950-1 [3]. This has already been done on copper twisted pair like in ISDN provided there is no problem due to POTS interface S/T. But it is recommended to consider how to use a voltage limited to -60 V DC and use more than one twisted pair if more power than the maximum defined limit for one pair is required. The 120V should be considered only when additional pairs are not available in a country and when the cluster power cabinet solution with power cable (see PW4 and 5) is not possible. Even for use in professional building the -60 V DC voltage on a pair is recommended to avoid destruction of equipment or problem of human safety in case of confusion with Ethernet pairs and Power over Ethernet.

NOTE 6: In the case of installation in a man hole with water ingress, the maximum DC voltage should be limited to lower than 120 V as the current limit is not limited to 60 mA. There is no compatibility of this lower voltage reverse powering and 60 V reverse powering. Example can be 12 V and 24 V reverse powering on very short distance or very low power.

5 Effect of the technologies on the powering strategy

Access network involves different technologies such as copper, optical fibre or radio. Between the exchange and the customer's terminal, the telecom network is achieved:

- either in one single technology (for instance "copper", for a big part of the present network or "optical fibre", for a future FTTH network or radio link); or
- in a combination of technologies (hybrid networks: copper/radio network, optical/copper, optical/radio).

These access network systems can be divided in two main families (see figure 4) according to the links between the telecom centre and the active equipment, and their consequences on powering:

- Family 1: system connected to a telecom centre by a metallic link. This family includes the copper access.
- Family 2: system connected to a telecom centre by a non-metallic link. This family includes the fibre access network (FTTH), the hybrid fibre/copper access network (FTTCab/FTTC/FTTB), the hybrid copper/radio access network and the radio access network.

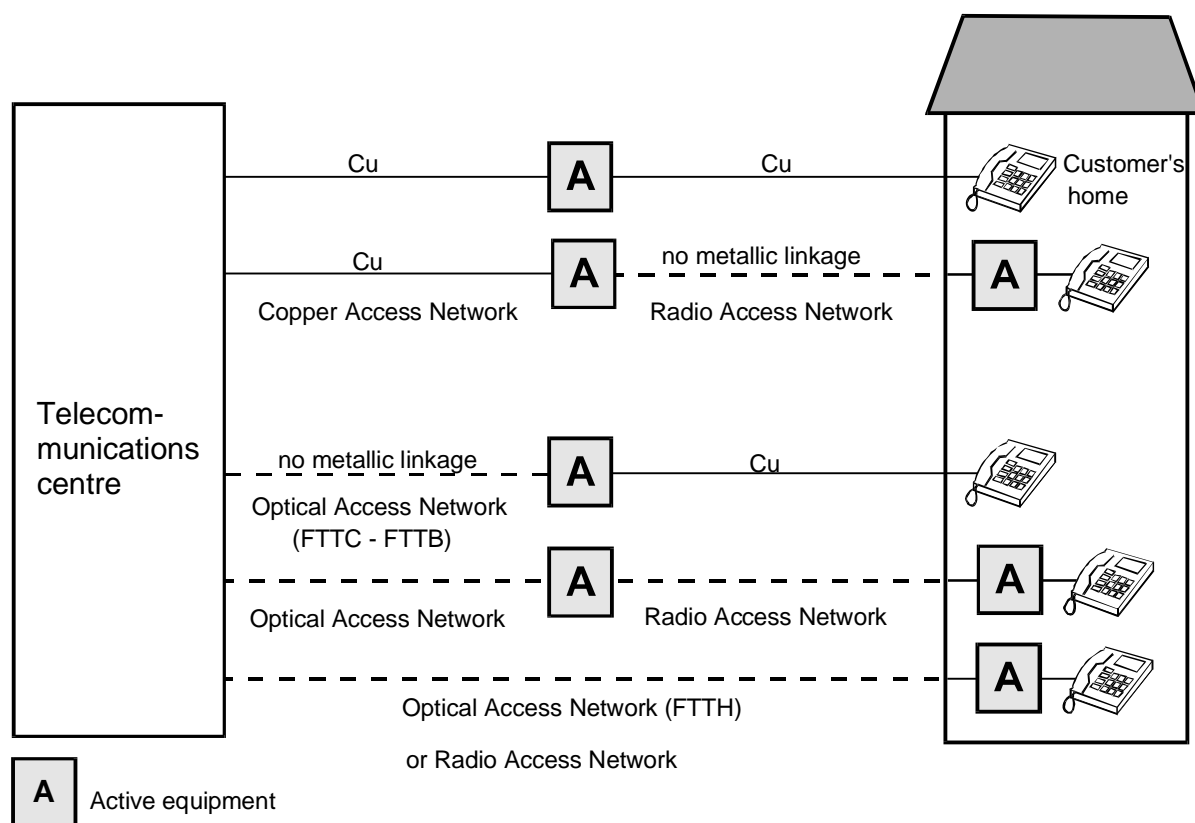

Figure 4: Access network technologies

5.1 Powering strategy of family 1: metallic links

The equipment of copper access network is generally powered according to the three principles defined as follows:

- a) due to a metallic link from the telecom centre to the access network equipment, the centralized **powering** (PW1a/PW1b and PW2a/PW2b in figure 1) can be used: remote power source with back-up in the central office and power ducts used by the (existing) copper pair(s). Such a solution can be developed if the power consumption of the equipment is not too high. The output voltage of the power source is defined in clause 7.2;
- b) when the power consumption of the access network equipment is higher, **local powering** has to be used. Two configurations are defined:
 - the power supply with back-up can be provided by a Local Power Unit (PW6 or PW8 in figure 3). The telecom operator is the provider of the LPU and the requirements at the interface "LPU/Telecom system" (I_4 of figure 3) are defined in clauses 6.2 to 6.4;
 - the power plant with back-up can also be included in the TE (PW7 or PW9 in figure 3). Clause 8 defines the requirements for the power back-up i.e. the conditions for the definition of a back-up time.
- c) for intermediate power consumption, the centralized powering can be completed by a local battery (PW3 in figure 1) which provides an additional power source in operation (discharge) when the traffic increases. Most part of time, the traffic is such that the power provided by remote powering is sufficient and the local battery is in charge. By daily cycles or occasionally, the local battery is used when the traffic increases.

5.2 Powering strategy of family 2: non-metallic links

The equipment of the fibre access network, the radio access network, the hybrid fibre/copper access network, the hybrid copper/radio access network and the hybrid fibre/radio access network are generally powered according to the three principles defined as follows:

- a) Since no "natural" electrical link connects the telecom centre to the Optical Network Unit (ONU), the **local powering** is the recommended solution in FTTB particularly for professional applying. As it was defined in clause 5.1 b), the power supply of the equipment can be provided either by a LPU (PW6 in figure 3) or directly from the mains (PW8 in figure 3). In the first case, the requirements at the interface LPU/ONU are defined in clauses 6.2 to 6.4. In the second case, the requirements for the power back-up are given in clause 8.
- b) When a lot of ONUs are implemented in one area, it may be cost effective to centralize their power supply in a RPU (located in the same area as the ONUs) as defined for **cluster powering** architecture (see clause 4.2). The power feeding from the RPU to the ONUs is generally ensured by dedicated power cables. The requirements on the output of the RPU are defined in clause 7.2.

The location of the battery for the power back-up of the telephone service can be either in the RPU (PW4 of figure 2) or in the TE (PW5 of figure 2). In the second configuration, the requirements on power back-up are given in clause 8.

- c) In some cases, the ONUs may be supplied by means of a **centralized powering** architecture (PW1b of figure 1). The requirements on the output of the RPU are defined in clause 7.2.

The powering of hybrid fibre/radio access network obeys the same principles than those defined in hybrid fibre/copper access network. The receiving equipment is a fixed part located at the customer's home. It is in any case powered locally (PW9 in figure 3) from the mains.

The fibre access network is characterized by the optical architectures FTTH, FTTB and FTTC.

Powering of radio access network is by **local powering**. As it was defined in clause 5.1 b) the power supply of the equipment can be provided directly from the mains (PW8 or PW9 in figure 3). In this case the requirements for power back-up are given in clause 8.

6 Requirements for local powering

6.1 TE including the power plant

The input voltage of the telecommunications equipment (at interface I_1 of clause 4) is nominal 230 V, 50 Hz.

A power back-up unit with batteries provides continuity of supply for the telephone service in the event of a mains outage or a failure of power equipment upstream of the batteries. The conditions of power back-up are defined in clause 8.

6.2 TE powered by a dc voltage nominal -48 V local power unit

The local power unit (LPU) supplies the functions of protection, power conversion and back-up of the telephone service.

The input voltage of the telecommunications equipment (at interface I_4 of clause 4) is -48 V. Its characteristics shall comply with the requirements detailed in EN 300 132-2 [2].

6.3 TE powered by a LPU with a dc voltage other than -48 V

Some items of access network telecommunications equipment require power supplies other than -48 V. This shall be mentioned in the individual technical specification of the equipment concerned.

NOTE: This clause does not take into account internal interface of a TE but the interface (at interface I_4) between a LPU and a TE.

6.4 TE powered by a nominal ac voltage of 230 V, 50 Hz local power unit

The local power unit (LPU) can be an Uninterruptible Power Supply which provides the functions of protection, power conversion and back-up for the telephone service. The input voltage of the TE (at interface I_4 of clause 4) is the nominal AC voltage 230 V, 50 Hz [5].

7 Requirements for remote powering

7.1 Input of the Remote Power Unit

In centralized powering, the Remote Power Unit is supplied through the power plant of a telecom centre. The input voltage of that equipment (at interface I_0 of clause 4) is -48 V. Its characteristics shall comply with the requirements detailed in EN 300 132-2 [2]. The input can be also at interface I_5 of clause 4.

In cluster powering, the input voltage of the Remote Power Unit (at interface I_1 of clause 4) is 230 V, 50 Hz.

NOTE: Up to 400 VDC may be used inside a cluster RPU, but the remote powering of RPU by up to 400 VDC is not considered in the present document as no safety requirement is available for it. For DC powering, it is only considered in the present document to use powering defined in IEC 60950-21 [4] and EN 302 999 [i.9].

7.2 Output of the Remote Power Unit

Two modes of remote powering are taken into account:

- a) Remote powering with a RFT-V circuit voltage mode.
- b) Remote powering with a RFT-C circuit current mode.

7.3 Input characteristics of remote powered receiver in the voltage mode

Remote powered receiver equipment (Interface I₃ of clause 4) shall at least accept an input voltage in the range of values between the nominal output voltage of the Remote Power Unit and half of that value.

7.4 Input characteristics of remote powered receiver in the current mode

The input voltage is constant, for the output voltage of the remote power unit varies in value dependent on the line length and the number of receiver equipment in series.

8 Power back-up

A power back-up system consisting of batteries provides continuity of supply for the telephone service in the event of mains outage or failure of power equipment upstream of the batteries.

NOTE: In the case of centralized remote powering, a standby source, such as a turbine or motor-driven generating set, could possibly supplement and reinforce back-up of supply.

Annex A gives the condition of battery size.

9 Power management

The operating status of the power sub-assemblies, providing power and possibly back-up of access network equipment, shall be known to the telecommunications operator to enable appropriate maintenance to be carried out. The power management data detailed in this clause are required for the access network equipment, itself designed with a management system connected to the Telecommunications Management Network.

The management interface shall be compliant with ES 202 336-1 [15].

According to the different powering architectures, the requirements on power management are given in table 1.

Table 1

Architectures	Management requirements
Centralized Powering:	
PW1a/PW1b/PW2a/PW2b/PW3	The TE of access network does not ensure the management of the powering.
Local Powering:	
PW6/PW7	The TE provides at least 3 alarm loops (category 1, 2, 3) to the LPU and transmits the alarms coming from the LPU by its management system. Local visual indication of alarms is required (e.g. LED).
PW8/PW9	The TE surveys the failure events defined in table 1. It transmits at least 3 alarms to its management system if a visual check or a simple test procedure allows to identify the fault.
Cluster Powering:	
PW4	The TE provides at least 3 alarm loops (category 1, 2, 3) to the RPU and transmits the alarms coming from the RPU to its management system. Local visual indication of alarms is required (e.g. LED).
PW5	The TE provides at least 2 alarms loops (category 1, 2, 3) or 3 alarm loops (when redundancy of a RPU's conversion module) to the RPU. The TE surveys the failure events defined in table 1. It transmits at least 3 alarms to its management system if a visual check or a simple test procedure allows to identify the fault.
Reverse powering:	
PW10	<p>The reversed power TE (e.g. ANU, ONU or ONT of FTTPd) shall provide an alarm to the Telecom Management Network, when the reverse power is interrupted. Without battery, there should be a sufficient energy reserve to send this message sometime called dying gasp.</p> <p>When there is a battery in the ANU, ONU or ONT, alarms are battery discharge for a defined time due to lack of reverse power or failure of DC/DC converter (alarm 8 table 2) and battery voltage very low (alarm 6 table 2) Battery test result might be offered (alarm 7). Local visual indication of alarms are required (e.g. LED) if battery.</p> <p>The alarms shall be sent by each TE through the fixed line or by radio link or by a management gathering unit (refer to ES 202 336-1 [15]). In any case alarm loops are required to gather the information from several TE of the same building at a single location (e.g. bottom of the building). At this location there can be an gathering unit.</p>

For configuration PW 4,5,6,7,8,9, table 2 indicates the information (failure events) which have to be controlled and the resulting alarms which should be communicated to the operator by the system via the management network. Alarms 2, 3, 5 and 6 may be combined together and alarms 4 and 7 too if, locally a visual check of the component involved or if a simple test procedure makes it possible to identify the fault. The consequences of alarms may be determined by the operator.

Table 2

Alarm- Warning	Category	Failure events
1) Loss of input power	1	- Mains outage
2) Power module failure number 1	3	- Failure of a power conversion module (rectifier, dc/dc converter etc.) with no redundancy - Failure of two modules of a (n+1) redundant system
3) Failure of a protection device	3	- Opening of a protection device (circuit breaker, fuse, relay contact etc.), except one integrated in a conversion module
4) Power module failure number 2	2	- Failure of one power conversion module (rectifier, converter, etc.) in a (n+1) redundant system
5) Monitoring unit alarm	3	- Failure of the power management and monitoring unit (management of battery charge etc.), if present. In the event of a monitoring unit failure, fallback mode operation is assured to ensure continuity of supply
6) Battery voltage too low	3	- Voltage level, characteristics of a significant level of discharge (excluding test)
7) Battery test alarm	2	- Test result: end of service life of battery
8) Lack of reverse power or battery discharge	2	- Battery voltage or current showing discharge due to internal failure or lack of reverse power

NOTE 1: Three levels of alarms are defined in tables 1 and 2:

- a) Category "1": An event happens which normally does not need a maintenance intervention of the network operator.
- b) Category "2": The failure event may need a maintenance intervention of the network operator but the service can be ensured without discharging the battery.
- c) Category "3": The failure event may need a not-delayed maintenance intervention of the network operator.

NOTE 2: In the cluster powering, due to the power management, the remote power unit and the distant TE's units cannot be designed independently. The means to transfer the information from the RPU to the distant Network Units can be very different: implementation of one Network Unit close to the RPU (which feeds other distant Network Units), specific information cables in parallel with power cables, information on current carrier, etc.

10 Safety, EMC, protection

10.1 Product Safety

The requirements for safety are outside the scope of the present document. Safety standards are published by CENELEC. Power Interfaces (table 3) shall comply with the referred standard.

NOTE 1: An example of such a CENELEC product safety standard is EN 60950-1 [3].

NOTE 2: For Safety categories of interfaces see TR 62102 [11].

NOTE 3: Examples of interfaces are in table 3. For A3 interface, high resistance mid point grounding is the highest safety and availability choice.

NOTE 4: For earthing and bonding of interface A3 [14] for 400 V DC see standard EN 301 605 [i.6].

Table 3

Interface	Category	According to
I ₁ or I ₅ (230 V, 50 Hz) or "A3" 260 V – 400 V DC interface	Hazardous	EN 60950-1 [3] EN 300 132-3-1 [14]
I ₄ (-48 V DC)	SELV	EN 60950-1 [3]
I ₂ or I ₃ , I ₆ (< 60 V / -60 V DC) (< 120 V DC)	SELV/TNV 1 TNV 2/3	EN 60950-1 [3]
I ₃ (< 60 mA)	RFT-C	IEC 60950-21 [4]
I ₄ (max. +140 V or max. +200 V, 10 mA)	RFT-V	IEC 60950-21 [4]

10.2 EMC

The telecommunications equipment shall comply with the relevant EMC standards.

10.3 Protection/resistibility

Telecommunications equipment of access network may be installed in very different locations which have nothing to do with telecom centres. The electrical environment is not so controlled and depends on the type of networks (aerial, buried, IT, TT, TN-C or TN-S mains distribution) [i.8].

Equipment which have to be supplied directly from the mains or through a UPS shall be designed by taking into account overvoltage categories as they are defined in EN 60664-1 [6] and Recommendation ITU-T K.45 [12], unless additional protection to be provided external to the equipment. Limits for power consumption in broadband telecommunication networks equipment shall comply with ES 203 215 [13].

10.4 Bonding and earthing

The bonding and earthing of equipment in access network shall comply with:

- requirements of EN 300 253 [9] for telecommunication equipment in a telecom centre; or
- requirements of EN 50310 [7] for information technology equipment in customer premises; or
- Recommendation ITU-T K.35 [10] for an equipment located in remote electronic sites;
- National regulations and electrical installation safety codes where applicable.

NOTE: For earthing and bonding of interface A3 [14] for 400 V see standard EN 301 605 [i.6].

11 Environmental conditions

EN 300 019-1-1 [i.1] defines the classification of the environmental conditions. EN 300 019-1-3 [i.2] specifies the classification of environmental conditions - Stationary use at weatherprotected locations. EN 300 019-1-4 [i.3] specifies the classification of environmental conditions - Stationary use at non-weatherprotected locations and EN 300 019-1-8 [i.4] for stationary use at underground locations. Table 4 gives the ETSI environmental classes applicable to three main locations for information.

Table 4: Examples for powering equipment locations (informative)

Powering Equipment Location	Weatherprotected locations					Class 4.1 Non-Weather-protected Locations	Class 8.1 Underground locations
	Class 3.1 Temperature Controlled Locations	Class 3.2 Partly Temperature controlled locations	Class 3.3 Not Temperature controlled locations	Class 3.4 Sites with Heat-trap	Class 3.5 Sheltered locations		
Outside plant	-	○	●	●	●	●	●
Inside a building	●	●	●	○	-	-	-
Customer home	●	○	-	-	-	-	-
<ul style="list-style-type: none"> ● Suitable for most cases. ○ Suitable for some cases. - Not suitable for most cases. 							

Annex A (normative): Battery sizing

The sizing of the battery is established at the discharging rate defined in clauses A.1 and A.2 with allowance for the combined effects of:

- a) **its ageing:** the battery capacity is sufficient to assure the discharging rate during the whole estimated service life of the battery (defined for the average operating temperature);
- b) **its environment conditions:** the battery capacity is sufficient to assure the discharging rate at the minimum operating temperature.

After a discharge at 20 °C defined by a constant discharge power (value P) with a back-up time equal to the autonomy value (A), the charge time of the battery does not exceed 2 times the discharge time in order to permit a second discharge with the same discharging rate than the first one.

The assessing compliance with these criteria is provided in accordance with the data of battery manufacturers.

A.1 Back-up power for telephone service

The power level to back-up P is established for the following conditions of consumption:

$$P = P_{\text{core}} + n \times (P_{\text{idle}} + \epsilon \times P_{\text{busy}})$$

where:

P_{core} = Maximum base power per equipment unit;

n = Maximum number of subscribers which can be connected to the equipment unit;

P_{idle} = Power per equipped service module without traffic;

ϵ = 0,1 (traffic of 0,1 Erlang) (see note 1);

P_{busy} = Operating power consumption per subscriber off-hook line.

NOTE 1: Selected number of off-hook subscribers is 0,1 Erlang, if no other values are required.

NOTE 2: The backed-up power is defined at the level of the battery after having taken into account the conversion stages of the system.

A.2 Autonomy of the back-up

When a TE is designed with its own power unit including back-up function, the provider of the equipment has to define **the autonomy** (back-up time) and **the minimum service life** of the battery for the back-up power defined in the precedent clause.

During an upstream power failure, the battery shall ensure normal operation of the telephone service equipment during the autonomy A for a discharge at a constant power level, as defined in the table A.1.

Table A.1

	P = Backed-up Power	A, Autonomy in discharge with a constant power (=P)
Equipment consumption depending on traffic	$P = P_{core} + n \times (P_{idle} + \varepsilon \times P_{busy})$	A
Equipment consumption independent of traffic	$P = P_{core} + n \times P_{idle}$	A
Equipment consumption independent of number of service units	$P = P_{core} + n \times \varepsilon \times P_{busy}$	A
Consumption of an equipment in customer's home ($n < 4$)	a) $P = P_{core} + n \times P_{idle}$	A ₁
	b) $P = P_{core} + n \times (P_{idle} + \varepsilon \times P_{busy})$	A ₂

NOTE: The purpose of this clause is to precise the conditions for which the autonomy of the battery is defined. There is no intention of the present document to require any value of autonomy, which can depend on the national requirements of the telecom operators in relation with the knowledge of their own electricity networks and their specific maintenance politics.

A.3 Use of valve regulated lead acid battery

Valve regulated lead acid batteries have to be conform to EN 60896-2 [8].

In a floating mode operation, the battery can be kept charged at a voltage level corrected as a function of the temperature. The charging current is limited in accordance with the manufacturer's recommendations.

In a discharge mode operation, a disconnecting device can be used to isolate the battery from the load at the end of discharging when the value of low-voltage disconnection defined by the manufacturer is reached.

A.4 End of service life of battery

A mechanism of periodic test of the battery can be provided. It proposes a criterion for a control of the ageing of the battery. The test is carried out automatically and establish whether the battery is capable of fulfilling its function or if the end of service life criterion is reached. The test ends with a report via the management system.

Annex B (informative): Bibliography

CENELEC HD 384: "Electrical installations of buildings".

History

Document history		
V1.1.1	January 2002	Publication
V2.0.0	December 2013	EN Approval Procedure AP 20140404: 2013-12-05 to 2014-04-04
V2.1.0	June 2014	Vote V 20140818: 2014-06-19 to 2014-08-18
V2.1.1	August 2014	Publication