

Draft **ETSI EN 302 099** V1.0.7 (2001-02)

---

*European Standard (Telecommunications series)*

**Environmental Engineering (EE);  
Powering of equipment in access network**

---



---

**Reference**

DEN/EE-02007

---

**Keywords**

AN, power supply

**ETSI**

650 Route des Lucioles  
F-06921 Sophia Antipolis Cedex - FRANCE

---

Tel.: +33 4 92 94 42 00 Fax: +33 4 93 65 47 16

Siret N° 348 623 562 00017 - NAF 742 C  
Association à but non lucratif enregistrée à la  
Sous-Préfecture de Grasse (06) N° 7803/88

---

**Important notice**

Individual copies of the present document can be downloaded from:

<http://www.etsi.org>

The present document may be made available in more than one electronic version or in print. In any case of existing or perceived difference in contents between such versions, the reference version is the Portable Document Format (PDF). In case of dispute, the reference shall be the printing on ETSI printers of the PDF version kept on a specific network drive within ETSI Secretariat.

Users of the present document should be aware that the document may be subject to revision or change of status. Information on the current status of this and other ETSI documents is available at <http://www.etsi.org/tb/status/>

If you find errors in the present document, send your comment to:  
editor@etsi.fr

---

**Copyright Notification**

No part may be reproduced except as authorized by written permission.  
The copyright and the foregoing restriction extend to reproduction in all media.

© European Telecommunications Standards Institute 2001.  
All rights reserved.

# Contents

Intellectual Property Rights .....	4
Foreword.....	4
1 Scope.....	5
2 References.....	5
3 Definitions and abbreviations.....	6
3.1 Definitions.....	6
3.2 Abbreviations.....	7
4 Powering configurations .....	7
4.1 Remote powering .....	9
4.1.1 Centralized powering .....	9
4.1.2 Cluster powering.....	9
4.2 Local powering .....	10
4.2.1 Telecom equipment of access network, common to several customers.....	10
4.2.2 Telecom equipment of access network, at customer's home.....	11
5 Effect of the technologies on the powering strategy.....	12
5.1 Powering strategy of family 1: metallic links .....	13
5.2 Powering strategy of family 2: non-metallic links .....	13
6 Requirements for local powering.....	14
6.1 Telecom equipment including the power plant .....	14
6.2 Telecom equipment powered by a DC voltage nominal -48 V local power unit.....	14
6.3 Telecom equipment powered by a LPU with a DC voltage other than -48 V .....	14
6.4 Telecom equipment powered by a nominal ac voltage nominal of 230 V, 50 Hz local power unit.....	14
7 Requirements for remote powering .....	14
7.1 Input of the Remote Power Unit.....	14
7.2 Output of the Remote Power Unit.....	14
7.3 Input characteristics of remote powered receiver in the voltage mode.....	15
7.4 Input characteristics of remote powered receiver in the current mode.....	15
8 Power back-up.....	15
9 Power management.....	15
10 Safety, EMC, protection.....	16
10.1 Product Safety.....	16
10.2 EMC.....	17
10.3 Protection / Resistibility .....	17
10.4 Bonding and earthing .....	17
11 Environmental conditions .....	17
<b>Annex A (normative): Battery sizing .....</b>	<b>19</b>
A.1 Back-up power for telephone service .....	19
A.2 Autonomy of the back-up.....	19
A.3 Use of valve regulated lead acid battery .....	20
A.4 End of service life of battery .....	20
History .....	21

---

## Intellectual Property Rights

IPRs essential or potentially essential to the present document may have been declared to ETSI. The information pertaining to these essential IPRs, if any, is publicly available for **ETSI members and non-members**, and can be found in ETSI SR 000 314: "*Intellectual Property Rights (IPRs); Essential, or potentially Essential, IPRs notified to ETSI in respect of ETSI standards*", which is available from the ETSI Secretariat. Latest updates are available on the ETSI Web server (<http://www.etsi.org/ipr>).

Pursuant to the ETSI IPR Policy, no investigation, including IPR searches, has been carried out by ETSI. No guarantee can be given as to the existence of other IPRs not referenced in ETSI SR 000 314 (or the updates on the ETSI Web server) which are, or may be, or may become, essential to the present document.

---

## Foreword

This European Standard (Telecommunications series) has been produced by ETSI Technical Committee Environmental Engineering (EE), and is now submitted for the Public Enquiry phase of the ETSI standards Two-step Approval Procedure.

<b>Proposed national transposition dates</b>	
Date of latest announcement of this EN (doa):	3 months after ETSI publication
Date of latest publication of new National Standard or endorsement of this EN (dop/e):	6 months after doa
Date of withdrawal of any conflicting National Standard (dow):	6 months after doa

---

# 1 Scope

The present document describes the principles for powering of telecommunications equipment in access network and contains requirements for the powering systems, laying down:

- the characteristics of the input and output interfaces of the power units;
- the power back-up conditions for telecom equipment including a power unit;
- the management data, necessary to guarantee the availability of the service and to ensure the maintenance of the power units.

The present document takes into account the characteristics of access network equipment for which the limits of responsibility in the installation or design of the power plants are very different than for equipment of telecom centre: it goes from "complete integration of the power plant in the telecom equipment" till "remote power feeding from a distant power plant".

The present document applies for the powering of all equipment of the access network (copper, fiber or radio networks) located outside telecommunications centres. The access network is defined as the part of the telecommunications network, which is comprised between the customer terminal installation and the first exchange (switching unit). The customer terminal and the switching unit are excluded of the application field of the present document.

---

# 2 References

The following documents contain provisions which, through reference in this text, constitute provisions of the present document.

- References are either specific (identified by date of publication and/or edition number or version number) or non-specific.
- For a specific reference, subsequent revisions do not apply.
- For a non-specific reference, the latest version applies.

- [1] ETSI ETS 300 132-1: "Equipment Engineering (EE); Power supply interface at the input to telecommunications equipment; Part 1: Operated by alternating current (ac) derived from direct current (dc) sources".
- [2] ETSI ETS 300 132-2: "Equipment Engineering (EE); Power supply interface at the input to telecommunications equipment; Part 2: Operated by direct current (dc)".
- [3] CENELEC HD 384: "Electrical installations of buildings".
- [4] CENELEC EN 60950: "Safety of information technology equipment".
- [5] CENELEC HD 472 S1 (1989): "Nominal voltages for low-voltage public electricity supply systems".
- [6] CENELEC HD 625-1: "Insulation coordination for equipment within low-voltage systems - Part 1: Principles requirements and tests".
- [7] CENELEC EN 50310: "Application of equipotential bonding and earthing in buildings with information technology equipment".
- [8] CENELEC EN 60896-2: "Stationary lead-acid batteries - General requirements and method of test - Part 2: Valve regulated types".
- [9] ETSI ETS 300 019-1-1: "Equipment Engineering (EE); Environmental conditions and environmental tests for telecommunications equipment; Part 1-1: Classification of environmental conditions; Storage".

- [10] ETSI ETS 300 019-1-3: "Equipment Engineering (EE); Environmental conditions and environmental tests for telecommunications equipment; Part 1-3: Classification of environmental conditions; Stationary use at weatherprotected locations".
- [11] ETSI ETS 300 019-1-4: "Equipment Engineering (EE); Environmental conditions and environmental tests for telecommunications equipment; Part 1-4: Classification of environmental conditions; Stationary use at non-weatherprotected locations".
- [12] ETSI ETS 300 019-1-8: "Equipment Engineering (EE); Environmental conditions and environmental tests for telecommunications equipment; Part 1-8: Classification of environmental conditions; Stationary use at underground locations".
- [13] ETSI ETS 300 253: "Equipment Engineering (EE); Earthing and bonding of telecommunication equipment in telecommunication centres".
- [14] ITU-T Recommendation K.35: "Bonding configurations and earthing at remote electronic sites".
- [15] ETSI EG 201 212: "Electrical safety; Classification of interfaces for equipment to be connected to telecommunication networks". (This document is also available from CENELEC as ROBT-002).
- [16] ITU-T Recommendation K.45: "Resistibility of access network equipment to overvoltages and overcurrents".

---

## 3 Definitions and abbreviations

### 3.1 Definitions

For the purposes of the present document the following terms and definitions apply:

**access network:** part of a telecommunications network between the customer terminal installation and the first switching unit

**local powering:** powering principle of a telecommunications equipment by a (dedicated) power unit implemented in the same location

**remote powering:** power feeding of a telecommunications equipment by a remote power circuit. Such a circuit consists of a remote power unit, distribution wiring, and fed receivers

**Remote Feeding Telecommunication (RFT) circuit:** secondary circuit within the equipment, intended to supply or receive dc power via a telecommunication network at voltages equal to or exceeding the limits for TNV circuits, and on which overvoltages from telecommunication networks are possible

**RFT-C circuit:** RFT circuit which is so designed and protected that under normal operating conditions and single fault conditions the currents in the circuit do not exceed defined values

**RFT-V circuit:** RFT circuit which is so designed and protected that under normal operating conditions and single fault conditions the voltages are limited and the accessible area of contact is limited

**centralized powering:** remote powering in which the remote feeding source is located in a telecommunications centre

**cluster powering:** remote powering of a cluster of equipment (1 to n items of equipment), in which the remote feeding source is located outside a telecommunications centre

**Remote Power Unit (RPU):** power unit, connected to the mains or from a centralized power plant, which supplies distant telecommunications equipment

**Distant Power Receiver:** power equipment electrically connected to a Remote Power Unit. Its function is to supply telecommunications equipment situated at the same location. It may be combined with the item of telecommunications equipment itself

**Local Power Unit (LPU):** power supply equipment whose function is to supply a telecommunications equipment situated at the same location. It is generally locally connected to the ac mains and provides dc or ac voltage output to feed telecommunication equipment

**SELV circuit:** (see EN 60950 [4])

**TNV circuit:** (see EN 60950 [4])

**Hazardous Voltage:** (see EN 60950 [4])

**primary circuit:** (see EN 60950 [4])

**secondary circuit:** (see EN 60950 [4])

## 3.2 Abbreviations

For the purposes of the present document, the following abbreviations apply:

ac	alternating current
CH	Customer's Home
dc	direct current
FTTB	Fibre To The Building
FTTC	Fibre To The Curb
FTTCab	Fibre To The Cabinet
FTTH	Fibre To The Home
LPU	Local Power Unit
ONU	Optical Network Unit
RFT	Remote Feeding Telecommunication
RPU	Remote Power Unit
TC	Telecommunication's Centre
TNV	Telecommunication Network Voltage
UPS	Uninterruptible Power Supply

---

## 4 Powering configurations

The main characteristic feature of the different powering architectures of access network equipment is the location of the following two functions:

- the point of connection to the mains; and
- the place of power back-up.

The total network can be divided in three main parts:

- 1) the Telecommunication Centre (TC);
- 2) the field (the undefined area between the Telecom Centre and the Customer's Home);
- 3) the Customer's Home (CH).

### Powering architectures

Equipment of access network can be powered remotely from a telecommunications centre (centralized powering) or from a power supply node (cluster powering), or locally from the mains (local powering). Inside these three main powering architectures, several configurations of powering are used. They are summarized in the clauses 4.1 to 4.2 and in the figures 1, 2 and 3 by the acronyms PW1 to PW 9 (for powering).

### Power back-up

For the telephone service, which needs to provide an available service even in the case of a mains outage, a power back-up unit is located either in the remote power source or in the equipment powered. The clauses 4.1 to 4.2 detail the different installation configurations.

### Location of the telecom equipment

On the figures 1, 2 and 3 of the following clauses, the telecom equipment in access network is schematically represented in the field. These figures mean that the telecom equipment can be implemented in different types of locations:

- in a customer's office;
- in a building, public or private;
- in an indoor cabinet;
- in a street cabinet;
- on a pole cabinet;
- in a telecommunications manhole, etc.

The telecom equipment provides services for several customers or for one professional customer.

On figure 3, the telecom equipment can be located at customer's home and provides services for only one private customer.

### Power interfaces

Six power-feeding interfaces are mentioned in the following clauses: They are as follows:

- $I_0$  = Power interface between a -48 V power plant and the fed equipment in a telecom centre. It fits with the interface "A" according to ETS 300 132-2 [2].
- $I_1$  = Power interface between the public mains (commercial ac) and the fed equipment. It fits with the voltage defined in HD 472 [5].
- $I_2$  = Power interface at the output of a remote power source.
- $I_3$  = Power interface at the input of a distant power receiver interface, in remote powering.
- $I_4$  = Power interface between a local power unit and the fed equipment, in local powering. It fits with the interface "A" according to ETS 300 132-2 [2] or with the interface defined in clauses 6.2 to 6.4.
- $I_5$  = Power interface between the public mains (commercial ac) or emergency power (UPS, diesel generator) or interface "A" according to ETS 300 132-1 [1] and the fed equipment in a telecom centre. It fits with the voltage defined in HD 472 [5].



## 4.1 Remote powering

### 4.1.1 Centralized powering

The different power supply configurations are detailed in figure 1. The output of the power source is defined at interface  $I_2$ . It comes from a telecom equipment (PW1a) or from a specific remote power unit (RPU in PW1b). Interface  $I_0$  corresponds to the input of the RPU. The remote power unit consists of protection and distribution devices and, possibly, power conversion equipment. Interface  $I_5$  corresponds to Interface  $I_1$  and is located in the telecommunication centre.

In some cases, the telecom equipment of the access network may be equipped with a battery providing additional power in periods of heavy traffic (PW3). This battery is recharged by the remote power supply during periods of light traffic.

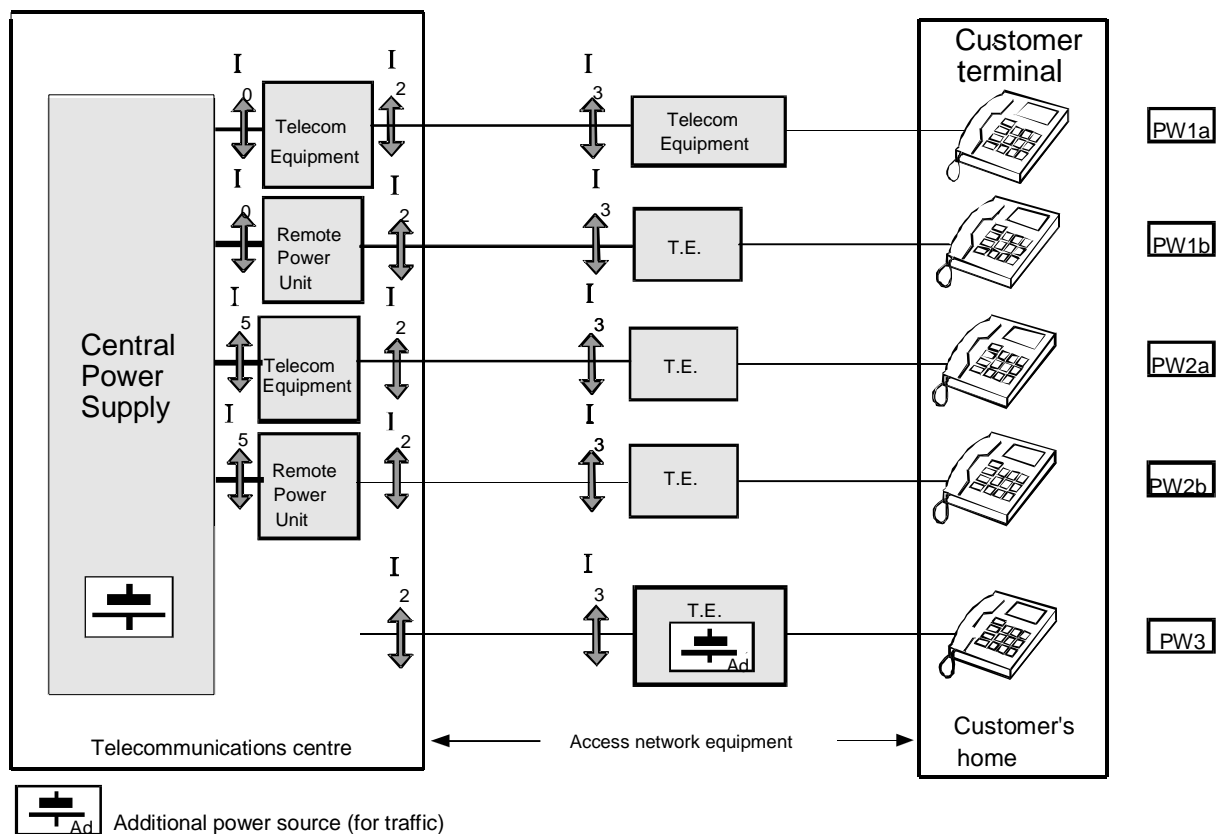

Figure 1: Centralized powering

### 4.1.2 Cluster powering

The different possible power supply configurations are detailed in figure 2. The remote power source, called Remote Power Unit (RPU), serves a group of distant telecommunications equipment, from 1 to  $n$ . The RPU is installed in a location (building, outdoor cabinet, manhole, etc.) which is distinct from the telecom equipment's building, cabinet or manhole. The telephone service is backed up by batteries located either at the remote power unit (remote powering with back-up at source, PW4) or in the telecommunications equipment (remote powering with local back-up, PW5).

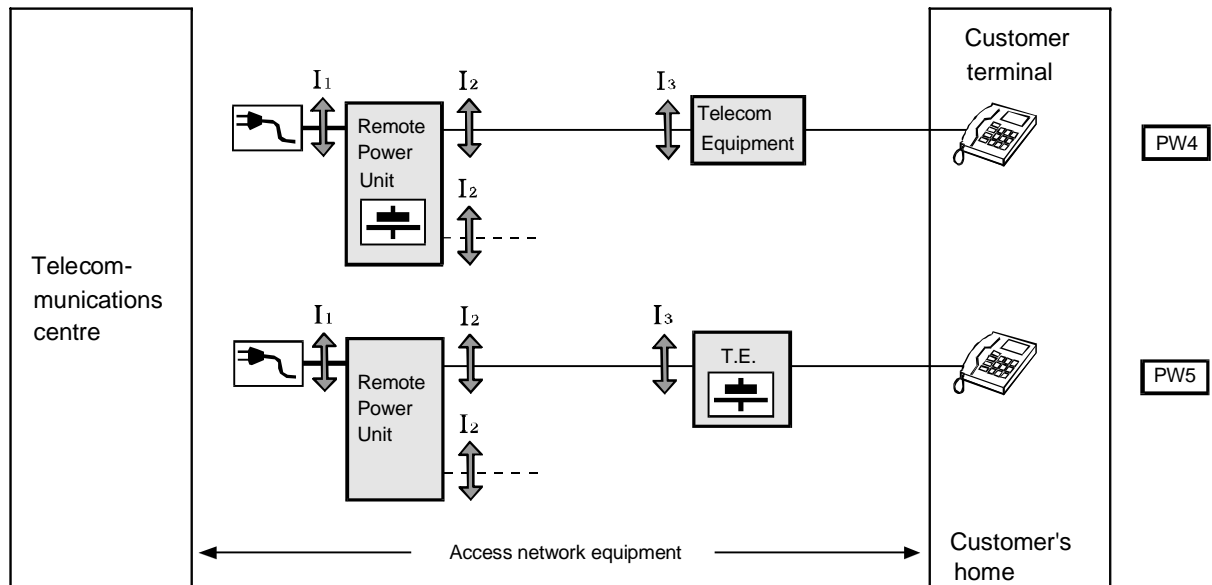

Figure 2: Cluster powering

## 4.2 Local powering

### 4.2.1 Telecom equipment of access network, common to several customers

The different possible local power supply configurations are detailed in figure 3. They are the following two basic types:

- the telecommunications equipment is powered (Interface  $I_4$ ) through a Local Power Unit (LPU in PW6) providing the functions of protection, power conversion and back-up of telephone service. It is either housed in the telecommunications equipment rack or installed in an independent mounting, but always in the same building or location as the telecom equipment.
- the telecommunications equipment is powered directly from the mains at Interface  $I_1$  (PW7). It includes protection devices, power conversion equipment and back-up blocks for telephone service.

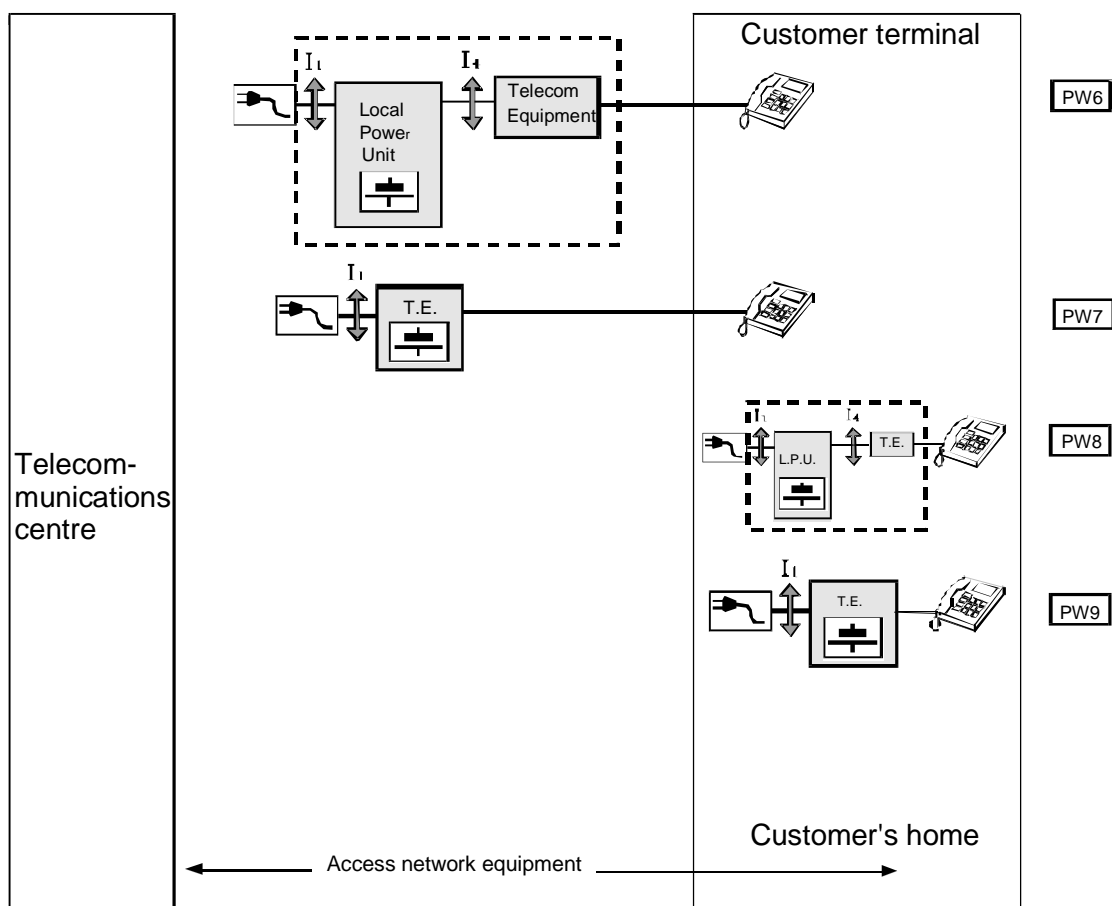

**Figure 3: Local powering**

#### 4.2.2 Telecom equipment of access network, at customer's home

The telecom equipment is located in a customer's home and provides services for a single private customer. Two types of power feeding are defined in local powering architecture:

- the telecommunications equipment is powered (interface  $I_4$ ) through a Local Power Unit (PW8) which may additionally provide backup;
- the telecommunications equipment provides usually back-up for telephone service when supplied by the mains or by UPS (PW9).

## 5 Effect of the technologies on the powering strategy

Access network involves different technologies such as copper, optical fiber or radio. Between the exchange and the customer's terminal, the telecom network is achieved:

- either in one single technology (for instance "copper", for a big part of the present network or "optical fiber", for a future FTTH network or radio link); or
- in a combination of technologies (hybrid networks: copper/radio network, optical/copper, optical/radio).

These access network systems can be divided in two main families (see figure 4) according to the links between the telecom centre and the active equipment, and their consequences on powering:

- Family 1: system connected to a telecom centre by a metallic link. This family includes the copper access.
- Family 2: system connected to a telecom centre by a non-metallic link. This family includes the fiber access network (FTTH), the hybrid fiber /copper access network (FTTcab/FTTC/FTTB), the hybrid copper/radio access network and the radio access network.

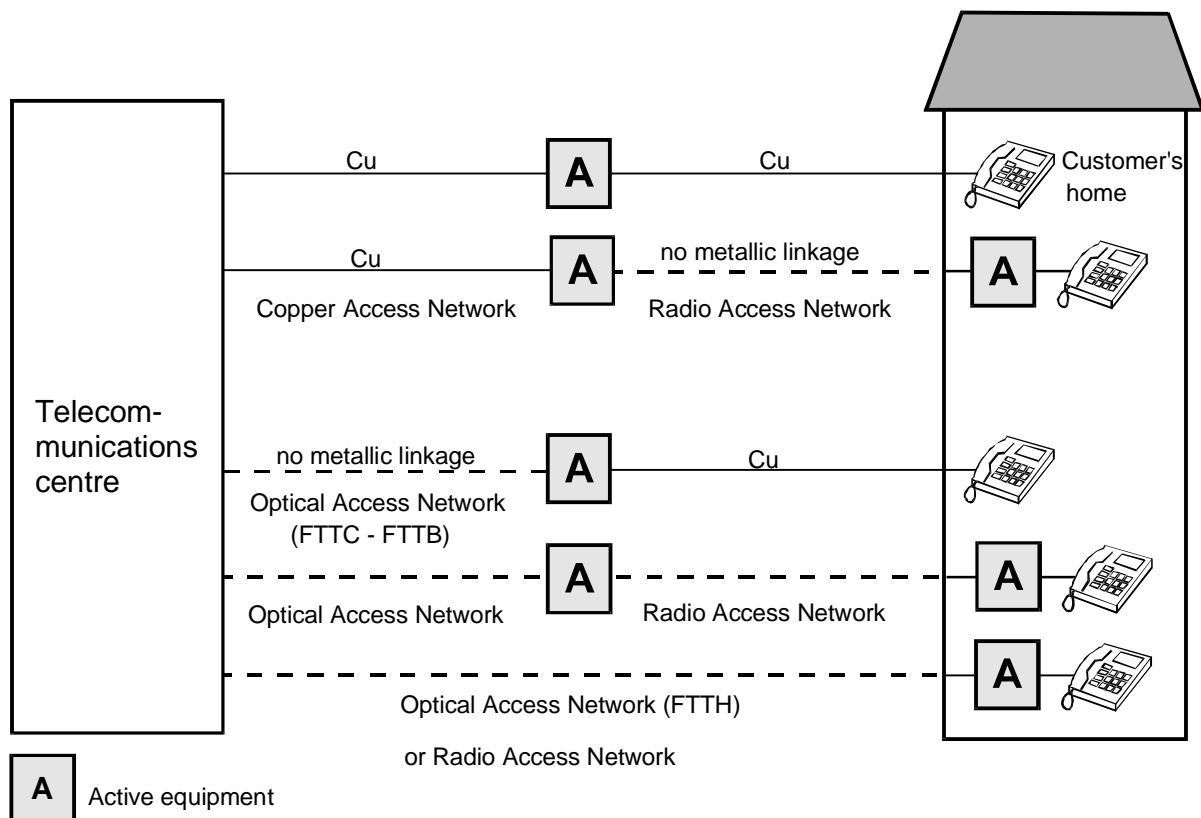

Figure 4: Access network technologies

## 5.1 Powering strategy of family 1: metallic links

The equipment of copper access network is generally powered according to the three principles defined as follows:

- a) due to a metallic link from the telecom centre to the access network equipment, the **centralized powering** (PW1a/PW1b and PW2a/PW2b in figure 1) can be used: remote power source with back-up in the central office and power ducts by the (existing) copper pair(s). Such a solution can be developed if the power consumption of the equipment is not too high. The output voltage of the power source is defined in clause 7.2.
- b) when the power consumption of the access network equipment is higher, a **local powering** has to be used. Two configurations are defined:
  - the power supply with back-up can be provided by a Local Power Unit (PW6 or PW8 in figure 3). The telecom operator is the provider of the LPU and the requirements at the interface "LPU/Telecom system" (I<sub>4</sub> of figure 3) are defined in clauses 6.2 to 6.4.
  - the power plant with back-up can also be included in the telecom equipment (PW7 or PW9 in figure 3). Clause 8 defines the requirements for the power back-up i.e. the conditions for the definition of a back-up time.
- c) for intermediate power consumption, the centralized powering can be completed by a local battery (PW3 in figure 1) which provides an additional power source in operation (discharge) when the traffic increases. During the most part of time, the traffic is such that the power provided by remote powering is sufficient and the local battery is in charge. By daily cycles or occasionally, the local battery is used when the traffic increases.

## 5.2 Powering strategy of family 2: non-metallic links

The equipment of the fiber access network, the radio access network, the hybrid fiber/copper access network, the hybrid copper/radio access network and the hybrid fiber/radio access network are generally powered according to the three principles defined as follows:

- a) Since no "natural" electrical link connects the telecom centre to the Optical Network Unit (ONU), the **local powering** is the recommended solution in FTTB particularly for professional applying. As it was defined in clause 5.1 b), the power supply of the equipment can be provided either by a LPU (PW6 in figure 3) or directly from the mains (PW8 in figure 3). In the first case, the requirements at the interface LPU/ONU are defined in clauses 6.2 to 6.4. In the second case, the requirements for the power back-up are given in clause 8.
- b) When a lot of ONUs are implemented in one area, it may be cost effective to centralize their power supply in a RPU (located in the same area than the ONUs) as defined for **cluster powering** architecture (clause 4.2). The power feeding from the RPU to the ONUs is generally ensured by dedicated power cables. The requirements on the output of the RPU are defined in clause 7.2.

The location of the battery for the power back-up of the telephone service can be either in the RPU (PW4 of figure 2) or in the telecom equipment (PW5 of figure 2). In the second configuration, the requirements on power back-up are given in clause 8.

- c) In some cases, the ONUs may be supplied by means of a **centralized powering** architecture (PW1b of figure 1). The requirements on the output of the RPU are defined in clause 7.2.

The powering of hybrid fiber/radio access network can obey to the same principles than those defined in hybrid fiber/copper access network. The receiving equipment is a fixed part located at the customer's home. It is in any case powered locally (PW9 in figure 3) from the mains.

The fiber access network is characterized by the optical architectures FTTH, FTTB and FTTC.

The powering of radio access network is the **local powering**. As it was defined in clause 5.1 b) the power supply of the equipment can be provided directly from the mains (PW8 or PW9 in figure 3). In this case the requirements for the power back-up are given in clause 8.

---

## 6 Requirements for local powering

### 6.1 Telecom equipment including the power plant

The input voltage of the telecommunications equipment (at interface  $I_1$  of clause 4) is nominal 230 V, 50 Hz.

A power back-up unit with batteries provides continuity of supply for the telephone service in the event of a mains outage or a failure of power equipment upstream of the batteries. The conditions of power back-up are defined in clause 8.

### 6.2 Telecom equipment powered by a DC voltage nominal -48 V local power unit

The local power unit (LPU) supplies the functions of protection, power conversion and back-up of the telephone service.

The input voltage of the telecommunications equipment (at interface  $I_4$  of clause 4) is -48 V. Its characteristics shall comply with the requirements detailed in ETS 300 132-2 [2].

### 6.3 Telecom equipment powered by a LPU with a DC voltage other than -48 V

Some items of access network telecommunications equipment require power supplies other than -48 V. This shall be mentioned in the individual technical specification of the equipment concerned.

NOTE: This clause does not take into account internal interface of a telecom equipment but the interface (at interface  $I_4$ ) between a LPU and a telecom equipment.

### 6.4 Telecom equipment powered by a nominal ac voltage nominal of 230 V, 50 Hz local power unit

The local power unit (LPU) can be an Uninterruptible Power Supply which provides the functions of protection, power conversion and back-up for the telephone service. The input voltage of the telecommunications equipment (at interface  $I_4$  of clause 4) is nominal 230 V, 50 Hz.

---

## 7 Requirements for remote powering

### 7.1 Input of the Remote Power Unit

In centralized powering, the Remote Power Unit is supplied through the power plant of a telecom centre. The input voltage of that equipment (at interface  $I_0$  of clause 4) is -48 V. Its characteristics shall comply with the requirements detailed in ETS 300 132-2 [2]. The input can be also at interface  $I_5$  of clause 4.

In cluster powering, the input voltage of the Remote Power Unit (at interface  $I_1$  of clause 4) is 230 V, 50 Hz.

### 7.2 Output of the Remote Power Unit

Two modes of remote powering are taken into account:

- a) Remote powering with a RFT-V circuit                      voltage mode.
- b) Remote powering with a RFT-C circuit                      current mode.

### 7.3 Input characteristics of remote powered receiver in the voltage mode

Remote powered receiver equipment (Interface I<sub>3</sub> of clause 4) shall at least accept input voltage range included values between the nominal output voltage of the Remote Power Unit and half of that value.

### 7.4 Input characteristics of remote powered receiver in the current mode

The input voltage is constant, for the output voltage of the remote power unit varies in value dependent on the line length and the number of receiver equipment in series.

---

## 8 Power back-up

A power back-up system consisting of batteries provides continuity of supply for the telephone service in the event of mains outage or failure of power equipment upstream of the batteries.

NOTE: In the case of centralized remote powering, a standby source, such as a turbine or motor-driven generating set, could possibly supplement and reinforce back-up of supply.

Annex A gives the condition of battery size.

---

## 9 Power management

The operating status of the power sub-assemblies, providing power and possibly back-up of access network equipment, shall be known to the telecommunications operator to enable appropriate maintenance to be carried out. The power management data detailed in this clause are required for the access network equipment, itself designed with a management system connected to the Telecommunications Management Network.

Table 1 indicates the bits of information (failure events) which have to be controlled and the resulting alarms which must be communicated to the operator by the system via the management network. Alarms 2, 3, 5 and 6 may be combined together and alarms 4 and 7 too if, locally a visual check of the component involved or if a simple test procedure makes it possible to identify the fault. The consequences of alarms may be determined by the operator.

**Table 1**

Alarm	Category	Failure events
1) Loss of input power	1	- Mains outage
2) Power module failure number 1	3	- Failure of a power conversion module (rectifier, DC/DC converter etc.) with no redundancy - Failure of two modules of a (n+1) redundant system
3) Failure of a protection device	3	- Opening of a protection device (circuit breaker, fuse, relay contact etc.), except one integrated in a conversion module
4) Power module failure number 2	2	- Failure of one power conversion module (rectifier, converter, etc.) in a (n+1) redundant system
5) Monitoring unit alarm	3	- Failure of the power management and monitoring unit (management of battery charge etc.), if present. In the event of a monitoring unit failure, fallback mode operation is assured to ensure continuity of supply
6) Battery voltage too low	3	- Voltage level, characteristics of a significant level of discharge (excluding test)
7) Battery test alarm	2	- Test result: end of service life of battery

According to the different powering architectures, the requirements on power management are given in table 2.

Table 2

Architectures	Management requirements
<b>Centralized Powering:</b> PW1a/PW1b / PW2a/PW2b / PW3	The telecom equipment of access network does not ensure the management of the powering.
<b>Local Powering:</b>  PW6 / PW7.....  PW8 / PW9.....	  The telecom equipment provides at least 3 alarm loops (category 1, 2, 3) to the LPU and transmits the alarms coming from the LPU by its management system.  The telecom equipment surveys the failure events defined in table 1. It transmits at least 3 alarms to its management system if a visual check or a simple test procedure allows to identify the fault.
<b>Cluster Powering:</b>  PW4.....  PW5.....	  The telecom equipment provides at least 3 alarm loops (category 1, 2, 3) to the RPU and transmits the alarms coming from the RPU to its management system.  The telecom equipment provides at least 2 alarms loops (category 1, 2, 3) or 3 alarm loops (when redundancy of a RPU's conversion module) to the RPU. The telecom equipment surveys the failure events defined in table 1. It transmits at least 3 alarms to its management system if a visual check or a simple test procedure allows to identify the fault.

NOTE 1: Three levels of alarms are defined in tables 1 and 2:

- a) Category "1": An event happens which normally does not need a maintenance intervention of the network operator.
- b) Category "2": The failure event may need a maintenance intervention of the network operator but the service can be ensured without discharging the battery.
- c) Category "3": The failure event may need a not-delayed maintenance intervention of the network operator.

NOTE 2: In the cluster powering, due to the power management, the remote power unit and the distant telecom equipment's units cannot be designed independently. The means to transfer the information's from the RPU to the distant Network Units can be very different: implementation of one Network Unit close to the RPU (which feeds other distant Network Units), specific information cables in parallel with power cables, information's on current carrier, etc.

---

## 10 Safety, EMC, protection

### 10.1 Product Safety

The requirements for safety are outside the scope of the present document. Safety standards are published by CENELEC.

NOTE 1: An example of such a CENELEC product safety standard is EN 60950 [4].

NOTE 2: For Safety categories of interfaces see EG 201 212 [15].

NOTE 3: Examples of interfaces are in table 3.



Table 3

Interface	Category	According to
I <sub>1</sub> or I <sub>5</sub> (230 V, 50 Hz)	Hazardous	EN 60950 [4]
I <sub>4</sub> (-48 V)	SELV	EN 60950 [4]
I <sub>2</sub> or I <sub>3</sub> (< 60 V) (< 120 V)	SELV / TNV 1 TNV 2/3	EN 60950 [4]
I <sub>3</sub> (< 60 mA)	RFT-C	under study in EN 60950 [4]
I <sub>4</sub> (max. ±140 V or max. ±200 V, 10 mA)	RFT-V	under study in EN 60950 [4]

## 10.2 EMC

The telecommunications equipment shall comply with the relevant EMC standards.

## 10.3 Protection / Resistibility

Telecommunications equipment of access network may be installed in very different locations which have nothing to do with telecom centres. The electrical environment is not so controlled and depends on the type of networks (aerial, buried, TT, TN-C or TN-S mains distribution).

Equipment which have to be supplied directly from the mains or through a UPS shall be designed by taking into account overvoltage categories as they are defined in HD 625-1 [6] and ITU-T Recommendation K.45 [16], unless additional protection to be provided external to the equipment.

## 10.4 Bonding and earthing

The bonding and earthing of equipment in access network shall comply with:

- requirements of ETS 300 253 [13] for telecommunication equipment in a telecom centre; or
- requirements of EN 50310 [7] for information technology equipment in customer premises; or
- ITU-T Recommendation K.35 [14] for an equipment located in remote electronic sites;
- National regulations and electrical installation safety codes where applicable.

---

# 11 Environmental conditions

ETS 300 019-1-1 [9] defines the classification of the environmental conditions. ETS 300 019-1-3 [10] specifies the classification of environmental conditions - Stationary use at weatherprotected locations. ETS 300 019-1-4 [11] specifies the classification of environmental conditions - Stationary use at non-weatherprotected locations and ETS 300 019-1-8 [12] for stationary use at underground locations. Table 4 gives the ETSI environmental classes applicable to three main locations for information.

Table 4: Examples for powering equipment locations (informative)

Powering Equipment Location	Weatherprotected locations					Class 4.1 Non-Weather-protected Locations	Class 8.1 Underground locations
	Class 3.1 Temperature Controlled Locations	Class 3.2 Partly Temperature controlled locations	Class 3.3 Not Temperature controlled locations	Class 3.4 Sites with Heat-trap	Class 3.5 Sheltered locations		
Outside plant	-	○	●	●	●	●	●
Inside a building	●	●	●	○	-	-	-
Customer home	●	○	-	-	-	-	-
<ul style="list-style-type: none"> <li>● Suitable for most cases.</li> <li>○ Suitable for some cases.</li> <li>- Not suitable for most cases.</li> </ul>							

---

## Annex A (normative): Battery sizing

The sizing of the battery is established at the discharging rate defined in clauses A.1 and A.2 with allowance for the combined effects of:

- a) **its ageing:** the battery capacity is sufficient to assure the discharging rate during the whole estimated service life of the battery (defined for the average operating temperature);
- b) **its environment conditions:** the battery capacity is sufficient to assure the discharging rate at the minimum operating temperature.

After a discharge at 20°C defined by a constant discharge power (value P) with a back-up time equal to the autonomy value (A), the charge time of the battery does not exceed 2 times the discharge time in order to permit a second discharge with the same discharging rate than the first one.

The assessing compliance with these criteria are provided in accordance with the data of battery manufacturers.

---

### A.1 Back-up power for telephone service

The power level to back-up P is established for the following conditions of consumption:

$$P = P_{\text{core}} + n \times (P_{\text{idle}} + \epsilon \times P_{\text{busy}})$$

where:

$P_{\text{core}}$  = Maximum base power per equipment unit;

n = Maximum number of subscribers which can be connected to the equipment unit;

$P_{\text{idle}}$  = Power per equipped service module without traffic;

$\epsilon$  = 0,1 (traffic of 0,1 Erlang) (see note 1);

$P_{\text{busy}}$  = Operating power consumption per subscriber off-hook line.

NOTE 1: Selected number of off-hook subscribers is 0,1 Erlang, if no other values are required.

NOTE 2: The backed-up power is defined at the level of the battery after having taken into account the conversion stages of the system.

---

### A.2 Autonomy of the back-up

When a telecom equipment is designed with its own power unit including back-up function, the provider of the equipment has to define **the autonomy** (back-up time) and **the minimum service life** of the battery for the back-up power defined in the precedent clause.

During an upstream power failure, the battery shall guarantee normal operation of the telephone service equipment during the autonomy A for a discharge at a constant power level, as defined in the table A.1.

Table A.1

	<b>P = Backed-up Power</b>	<b>A, Autonomy in discharge with a constant power (=P)</b>
Equipment consumption depending on traffic	$P = P_{core} + n \times (P_{idle} + \epsilon \times P_{busy})$	A
Equipment consumption independent of traffic	$P = P_{core} + n \times P_{idle}$	A
Equipment consumption independent of number of service units	$P = P_{core} + n \times \epsilon \times P_{busy}$	A
Consumption of an equipment in customer's home ( $n < 4$ )	a) $P = P_{core} + n \times P_{idle}$	A <sub>1</sub>
	b) $P = P_{core} + n \times (P_{idle} + \epsilon \times P_{busy})$	A <sub>2</sub>

NOTE: The purpose of this clause is to precise the conditions for which the autonomy of the battery is defined. There is no intention of the present document to require any value of autonomy, which can depend on the national requirements of the telecom operators in relation with the knowledge of their own electricity networks and their specific maintenance politics.

---

### A.3 Use of valve regulated lead acid battery

Valve regulated lead acid batteries have to be conform to EN 60 896-2 [8].

In a floating mode operation, the battery can be kept charged at a voltage level corrected as a function of the temperature. The charging current is limited in accordance with the manufacturer's recommendations.

In a discharge mode operation, a disconnecting device can be used to isolate the battery from the load at the end of discharging when the value of low-voltage disconnection defined by the manufacturer is reached.

---

### A.4 End of service life of battery

A mechanism of periodic test of the battery can be provided. It proposes a criterion for a control of the ageing of the battery. The test is carried out automatically and establish whether the battery is capable of fulfilling its function or if the end of service life criterion is reached. The test ends with a report via the management system.

---

## History

Document history		
V1.0.7	February 2001	Public Enquiry PE 20010629: 2001-02-28 to 2001-06-29