

**Digital Enhanced Cordless Telecommunications (DECT);  
Cordless Terminal Mobility (CTM);  
Feature Package 1 (FP1);  
CTM circuit-switched data profile, 32 kbit/s and 64 kbit/s  
Unrestricted Digital Information (UDI)**

---



---

**Reference**

DEN/DECT-030127 (jeo000pc.PDF)

---

**Keywords**

DECT, CTM, mobility, network

**ETSI**

---

**Postal address**

F-06921 Sophia Antipolis Cedex - FRANCE

---

**Office address**

650 Route des Lucioles - Sophia Antipolis  
Valbonne - FRANCE  
Tel.: +33 4 92 94 42 00 Fax: +33 4 93 65 47 16  
Siret N° 348 623 562 00017 - NAF 742 C  
Association à but non lucratif enregistrée à la  
Sous-Préfecture de Grasse (06) N° 7803/88

---

**Internet**

secretariat@etsi.fr  
Individual copies of this ETSI deliverable  
can be downloaded from  
<http://www.etsi.org>  
If you find errors in the present document, send your  
comment to: editor@etsi.fr

---

**Copyright Notification**

No part may be reproduced except as authorized by written permission.  
The copyright and the foregoing restriction extend to reproduction in all media.

© European Telecommunications Standards Institute 1999.  
All rights reserved.

# Contents

Intellectual Property Rights.....	5
Foreword.....	5
1 Scope.....	6
2 References.....	6
3 Definitions and abbreviations.....	7
3.1 Definitions.....	7
3.2 Abbreviations.....	9
4 Description of services.....	10
4.1 Reference configuration.....	10
4.2 Service objectives.....	11
4.2.1 General.....	11
5 NWK layer requirements.....	11
5.1 General.....	11
5.2 Requirements.....	12
6 DLC layer requirements.....	12
6.1 C-plane requirements.....	12
6.2 U-plane requirements.....	12
7 MAC layer requirements.....	12
8 PHL layer requirements.....	12
9 Management requirements.....	12
<b>Annex A (normative): Aspects of V.120 for use with CTM FP1.....</b>	<b>13</b>
A.1 Terminal adaptation sublayer.....	13
A.1.1 Mode of operation.....	13
A.1.2 Logical links.....	13
A.1.3 Parameter negotiation.....	14
A.1.4 Bearer service.....	14
A.1.5 Terminal adoption header.....	14
A.1.6 Mode of transmission.....	14
A.2 Data Link control and core sublayer.....	14
A.2.1 Signalling protocols.....	14
A.2.2 System parameters.....	15
A.3 Physical sublayer.....	15
<b>Annex B (normative): Interworking.....</b>	<b>16</b>
B.1 Interworking to connection-oriented bearer services.....	16
B.1.1 Scope.....	16
B.1.2 Reference configuration.....	16
B.1.3 Interworking service of DTE using V.24 connection.....	17
B.1.3.1 General.....	17
B.1.3.2 TAF interworking to ITU-T Recommendation V.24.....	17
B.1.3.2.1 General.....	17
B.1.3.2.2 V.24 Interchange circuit handling rules.....	17
B.1.3.2.3 Call establishment signalling handling.....	18
B.1.3.3 DECT FP Interworking procedures.....	18
B.1.3.3.1 General.....	18
B.1.3.3.2 Call establishment signalling handling.....	19

B.1.3.3.3	Modem selection.....	19
B.2	<<IWU-ATTRIBUTES>> coding.....	23
	Bibliography.....	27
	History.....	28

---

## Intellectual Property Rights

IPRs essential or potentially essential to the present document may have been declared to ETSI. The information pertaining to these essential IPRs, if any, is publicly available for **ETSI members and non-members**, and can be found in SR 000 314: *"Intellectual Property Rights (IPRs); Essential, or potentially Essential, IPRs notified to ETSI in respect of ETSI standards"*, which is available **free of charge** from the ETSI Secretariat. Latest updates are available on the ETSI Web server (<http://www.etsi.org/ipr>).

Pursuant to the ETSI IPR Policy, no investigation, including IPR searches, has been carried out by ETSI. No guarantee can be given as to the existence of other IPRs not referenced in SR 000 314 (or the updates on the ETSI Web server) which are, or may be, or may become, essential to the present document.

---

## Foreword

This European Standard (Telecommunications series) has been produced by ETSI Project Digital Enhanced Cordless Telecommunications (DECT), and is now submitted for the Public Enquiry phase of the ETSI Two-step Approval Procedure.

The present document is based on ETS 300 175-1 to 8 [1] to [8] and ETS 300 824 [10]. General attachment requirements are based on TBR 6 [19] and, where applicable, voice attachment requirements are based on TBR 10 [20].

The present document has been developed in accordance to the rules of documenting a profile specification as described in ISO/IEC 9646-6 [11].

<b>Proposed national transposition dates</b>	
Date of latest announcement of this EN (doa):	3 months after ETSI publication
Date of latest publication of new National Standard or endorsement of this EN (dop/e):	6 months after doa
Date of withdrawal of any conflicting National Standard (dow):	6 months after doa

---

# 1 Scope

The present document specifies that set of technical requirements for Digital Enhanced Cordless Telecommunications (DECT) Fixed Part (FP) and DECT Portable Part (PP) necessary for the support of the Cordless Terminal Mobility (CTM) Feature Package 1 (CTM-FP1).

The objective of the present document is to ensure the Air Interface (AI) interoperability of DECT CTM-FP1 PPs and DECT CTM-FP1 FPs if applied.

The CTM service allows users of cordless terminals to be mobile within and between networks. Where radio coverage is provided and the cordless terminal has appropriate access rights the user shall be able to make calls from, and to receive calls at, any location within the fixed public and/or private networks, and may move without interruption of a call in progress.

CTM-FP1 defines 32Kbit/sec Circuit Switched Data services (CSD) for CTM users.

The present document is intended as an extension of the DECT CTM Access Profile (ETS 300 824 [10]) mobility features mandatory base covering the requirements for CTM-FP1.

---

# 2 References

The following documents contain provisions which, through reference in this text, constitute provisions of the present document.

- References are either specific (identified by date of publication, edition number, version number, etc.) or non-specific.
- For a specific reference, subsequent revisions do not apply.
- For a non-specific reference, the latest version applies.
- A non-specific reference to an ETS shall also be taken to refer to later versions published as an EN with the same number.

- [1] ETS 300 175-1: "Digital Enhanced Cordless Telecommunications (DECT); Common Interface (CI); Part 1: Overview".
- [2] ETS 300 175-2: "Digital Enhanced Cordless Telecommunications (DECT); Common Interface (CI); Part 2: Physical layer (PHL)".
- [3] ETS 300 175-3: "Digital Enhanced Cordless Telecommunications (DECT); Common Interface (CI); Part 3: Medium Access Control (MAC) layer".
- [4] ETS 300 175-4: "Digital Enhanced Cordless Telecommunications (DECT); Common Interface (CI); Part 4: Data Link Control (DLC) layer".
- [5] ETS 300 175-5: "Digital Enhanced Cordless Telecommunications (DECT); Common Interface (CI); Part 5: Network (NWK) layer".
- [6] ETS 300 175-6: "Digital Enhanced Cordless Telecommunications (DECT); Common Interface (CI); Part 6: Identities and addressing".
- [7] ETS 300 175-7: "Digital Enhanced Cordless Telecommunications (DECT); Common Interface (CI); Part 7: Security features".
- [8] ETS 300 175-8: "Digital Enhanced Cordless Telecommunications (DECT); Common Interface (CI); Part 8: Speech coding and transmission".
- [9] EN 300 444 (V1.2): "Digital Enhanced Cordless Telecommunications (DECT); Generic Access Profile (GAP)".

- [10] ETS 300 824: "Digital Enhanced Cordless Telecommunications (DECT); Cordless Terminal Mobility (CTM); CTM Access Profile (CAP)".
- [11] ISO/IEC 9646-6: "Information technology - Open Systems Interconnection - Conformance testing methodology and framework - Part 6: Protocol profile test specification".
- [12] CCITT Recommendation Q.922: "ISDN data link layer specification for frame mode bearer services".
- [13] ITU-T Recommendation Q.931: "Digital Subscriber Signalling System No. 1 (DSS 1) - ISDN user-network interface layer 3 specification for basic call control".
- [14] ITU-T Recommendation Q.933: "Integrated services digital network (ISDN) digital subscriber signalling system no. 1 (DSS 1) - signalling specifications for frame mode switched and permanent virtual connection control and status monitoring".
- [15] ITU-T Recommendation V.24: "List of definitions for interchange circuits between data terminal equipment (DTE) and data circuit-terminating equipment (DCE)".
- [16] ITU-T Recommendation V.42bis: "Data compression procedures for data circuit terminating equipment (DCE) using error correction procedures".
- [17] ITU-T Recommendation V.110: "Support by an ISDN of data terminal equipments with V-Series type interfaces".
- [18] ITU-T Recommendation V.120: "Support by an ISDN of data terminal equipment with V-Series type interfaces with provision for statistical multiplexing".
- [19] TBR 6: "Digital Enhanced Cordless Telecommunications (DECT); General terminal attachment requirements".
- [20] TBR 10: "Digital Enhanced Cordless Telecommunications (DECT); General terminal attachment requirements; Telephony applications".

---

## 3 Definitions and abbreviations

### 3.1 Definitions

For the purposes of the present document, the following definitions apply:

**authentication:** the process whereby a DECT subscriber is positively verified to be a legitimate user of a particular FP.

NOTE 1: Authentication is generally performed at call set-up, but may also be done at any other time (e.g. during a call).

**bearer service:** a type of telecommunication service that provides a defined capability for the transmission of signals between user-network interfaces.

NOTE 2: The DECT user-network interface corresponds to the top of the Network (NWK) layer (layer 3).

**C-plane:** the control plane of the DECT protocol stacks, which contains all of the internal DECT protocol control, but may also include some external user information.

NOTE 3: The C-plane stack always contains protocol entities up to and including the NWK layer.

**call:** all of the NWK layer processes involved in one NWK layer peer-to-peer association.

NOTE 4: Call may sometimes be used to refer to processes of all layers, since lower layer processes are implicitly required.

**DECT network:** a network that uses the DECT AI to interconnect a local network to one or more portable applications. The logical boundaries of the DECT network are defined to be at the top of the DECT NWK layer.

NOTE 5: A DECT network is a logical grouping that contains one or more FTs plus their associated PT. The boundaries of the DECT network are not physical boundaries.

**Fixed Part (DECT Fixed Part) (FP):** a physical grouping that contains all of the elements in the DECT network between the local network and the DECT AI.

NOTE 6: A DECT FP contains the logical elements of at least one FT, plus additional implementation specific elements.

**Fixed radio Termination (FT):** a logical group of functions that contains all of the DECT processes and procedures on the fixed side of the DECT AI.

NOTE 7: A FT only includes elements that are defined in the DECT Common Interface (CI) standard. This includes radio transmission elements together with a selection of layer 2 and layer 3 elements.

**global network:** a telecommunication network capable of offering a long distance telecommunication service.

NOTE 8: The term does not include legal or regulatory aspects, nor does it indicate if the network is a public or a private network.

**handover:** the process of switching a call in progress from one physical channel to another physical channel.

NOTE 9: There are two physical forms of handover, intra-cell handover and inter-cell handover.

**incoming call:** a call received at a PP.

**inter-operability:** the capability of FPs and PPs, that enable a PP to obtain access to teleservices in more than one Location Area (LA) and/or from more than one operator (more than one service provider).

**inter-operator roaming:** roaming between FP coverage areas of different operators (different service providers).

**Interworking Unit (IWU):** a unit that is used to interconnect sub networks.

NOTE 10: The IWU will contain the interworking functions necessary to support the required sub-network interworking.

**isochronous:** pertaining to a signal or a time-varying phenomenon characterized by significant instants separated by time intervals having a duration theoretically equal to the duration of a unit interval or to an integral multiple of this duration.

**Local Network (LNW):** a telecommunication network capable of offering local telecommunication services.

NOTE 11: The term does not include legal or regulatory aspects, nor does it indicate if the network is a public network or a private network.

**MAC connection (connection):** an association between one source MAC Multiple Bearer Control (MBC) entity and one destination MAC MBC entity. This provides a set of related MAC services (a set of logical channels), and it can involve one or more underlying MAC bearers.

**outgoing call:** a call originating from a PP.

**Portable Application (PA):** a logical grouping that contains all the elements that lie beyond the DECT network boundary on the portable side.

NOTE 12: The functions contained in the PA may be physically distributed, but any such distribution is invisible to the DECT network.

**Portable Part (DECT Portable Part) (PP):** a physical grouping that contains all elements between the user and the DECT AI. PP is a generic term that may describe one or several physical pieces.

NOTE 13: A DECT PP is logically divided into one PT plus one or more PAs.



**Portable radio Termination (PT):** a logical group of functions that contains all of the DECT processes and procedures on the portable side of the DECT AI.

NOTE 14: A PT only includes elements that are defined in the DECT CI standard. This includes radio transmission elements (layer 1) together with a selection of layer 2 and layer 3 elements.

**Radio Fixed Part (RFP):** one physical sub-group of a FP that contains all the radio end points (one or more) that are connected to a single system of antennas.

**synchronous:** the essential characteristics of time-scales or signals such that their corresponding significant instants occur at precisely the same average rate.

**synchronous transmission:** transmission using isochronous signals in which the sending and receiving instruments are operating continuously in a constant time difference between corresponding significant instants.

## 3.2 Abbreviations

For the purposes of the present document, the following abbreviations apply:

AAL	ATM Adaptation Layer
AI	Air Interface
ATM	Asynchronous Transfer Mode
CAP	CTM Access Profile
CC	Call Control
CI	Common Interface
CSD	Circuit Switched Data
CTM	Cordless Terminal Mobility
CTM-FP1	Cordless Terminal Mobility Feature Package 1
DCE	Data Communication Equipment
DECT	Digital Enhanced Cordless Telecommunications
DLC	Data Link Control
DTE	Data Terminal Equipment
FP	Fixed Part
FT	Fixed radio Termination
GAP	Generic Access Profile
GSM	Global System for Mobile communication
ISDN	Integrated Services Digital Network
IWF	Interworking Functions
IWU	Interworking Unit
IWF	Interworking Function
LCE	Link Control Entity
LNW	Local Network
MAC	Medium Access Control
MBC	Multiple Bearer Control
MM	Mobility Management
NWK	Network
PA	Portable Application
PHL	Physical layer
PP	Portable Part
PT	Portable radio Termination
RFP	Radio Fixed Part
SAP	Service Access Point
TAF	Terminal Adoption Functions

## 4 Description of services

### 4.1 Reference configuration

The reference configuration for this profile shall be as shown in figure 1.

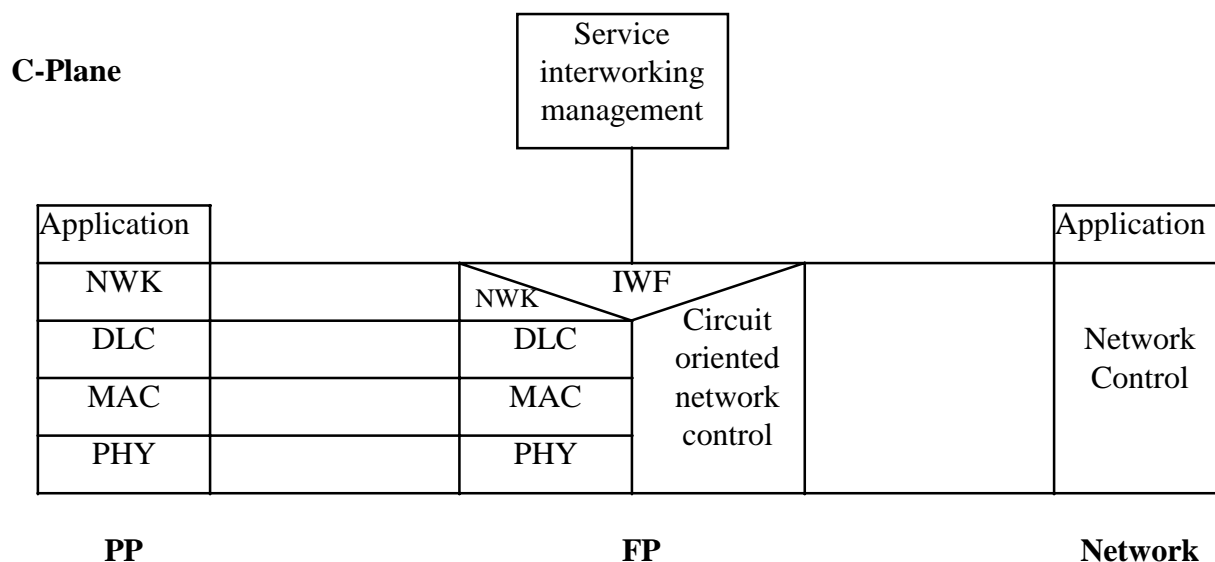

**U-Plane**

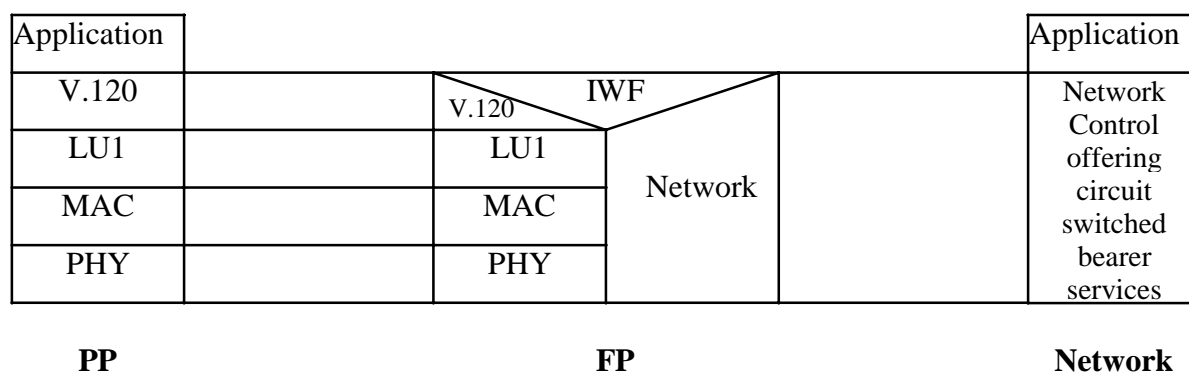

**Figure 1: Profile reference configuration showing interworking to connection-oriented networks via the C-plane and U-plane**

## 4.2 Service objectives

### 4.2.1 General

The service objectives for the C-plane are those of CTM feature package 1 as described in the CTM FP1 Service Description.

The service objectives for the U-plane are listed in subclauses 4.2.2.

The U-plane service objective for the 32 kbit/s service are detailed in table 1:

**Table 1: Service objectives of the 32 kbit/s service**

<b>Transfer mode</b>	<b>Circuit mode</b>
Transfer capability	Unrestricted digital
Data structure integrity	octet
Continuous data rate	by steps of 2,4 kbit/s up to 28,8 kbit/s; and by steps of 4 kbit/s up to 28,0 kbit/s
User data protection	optional
Service change and negotiation	optional
Encryption support	Mandatory
User data compression	Optional (note 1)

NOTE: User data compression may be used only if user data are protected. Data compression shall be achieved according to ITU-T Recommendation V.42bis [16].

---

## 5 NWK layer requirements

### 5.1 General

The NWK layer provisions shall include the following entities:

- Call Control (CC);
- Link Control Entity (LCE);
- Mobility Management (MM).

Portable Part and Fixed Part CC entities shall use circuit switched mode procedures.

Annex B specifies how procedures shall be used.

The MM requirements shall be aligned to the requirements of the CAP, defined in ETS 300 824 [10].

The provisions of NWK layer, ETS 300 175-5 [5] shall be implemented with respect to the services, procedures, messages and information elements coding listed in annex B. The provisions of ETS 300 175-6 [6] shall be implemented with respect to the structure and use of identities.

Support for exchanged attribute procedures shall be mandatory (ETS 300 175-5 [5], subclause 15.2.3).

The <<RELEASE-REASON>> element shall always be included in the {CC-RELEASE-COM} message.

## 5.2 Requirements

The full requirements of the GAP, defined in EN 300 444 [9] clause 8, and CAP, defined in ETS 300 824 [10] clause 9, shall apply, with the following exceptions and/or additions:

- a) both PP and FP shall set the info element <<BASIC SERVICE>> (defined in ETS 300 175-5 [5], subclause 7.6.4) to " Other" value;
- b) both PP and FP shall support the information element <<IWU-ATTRIBUTES>>, (defined in ETS 300 175-5 [5], subclause 7.7.21) in {CC-SETUP} and {CC-RELEASE-COM} messages;
- c) both PP and FP shall support the information element <<RELEASE-REASON>> (defined in ETS 300 175-5 [5], subclause 7.6.7);
- d) for a safe treatment of incoming call the PP shall inform the network that it supports CTM FP1. PP shall set bit 7 of octet 4a (profile Indicator\_2 Coding) of <<Terminal Capabilities>> IE;
- e) for a safe treatment of outgoing call the network shall inform the PP that it supports CTM FP1. FT shall set bit a35 of Extended higher layer capabilities message (see [5] clause F.2).

The specific coding required for the <<IWU-ATTRIBUTES>> information element is defined in clause B.2 of the present document.

---

## 6 DLC layer requirements

The DLC layer shall contain two independent planes of protocol: the C-plane and the U-plane. All internal DECT protocol control shall be handled by the C-plane. All external user data and control shall be handled by the U-plane.

### 6.1 C-plane requirements

The requirements defined in ETS 300 824 [10] clause 10 shall apply.

### 6.2 U-plane requirements

The requirements described in annex A (and derived from ITU-T Recommendation V.120 [18]) of the present document shall apply.

---

## 7 MAC layer requirements

The requirements defined in ETS 300 824 [10] clause 11 shall apply.

---

## 8 PHL layer requirements

To carry data information ETS 300 824 [10] clause 12 shall apply.

NOTE: ADPCM modulation/demodulation is not supported.

---

## 9 Management requirements

The requirements defined in ETS 300 824 [10] clause 14 shall apply.

## Annex A (normative): Aspects of V.120 for use with CTM FP1

FP and PP conformable to CTM FP1 shall adopt ITU-T Recommendation V.120 [18] rate adaptation protocol upon LU1 (Transparent Unprotected Data) SAP.

ITU-T Recommendation V.120 [18] allows both unprotected and protected data transmission respectively using unnumbered frame (UI) or numbered frame at data link control sublayer (see annex B.2).

User data may be compressed according to ITU-T Recommendation V.42bis [16] only if multiple frame are used.

V.120 is specified in ITU-T Recommendation V.120 [18] and consists of four different sublayers as shown in figure A.1.

Terminal adaptation sublayer
Data link control sublayer
Data link core sublayer
Physical layer

**Figure A.1 Protocol layers defined in ITU-T Recommendation V.120 [18]**

The following subclauses describe the options that shall be chosen in different sublayers to be CTM FP1 conform.

### A.1 Terminal adaptation sublayer

#### A.1.1 Mode of operation

ITU-T Recommendation V.120 [18] defines three modes of terminal adoption:

- 1) protocol sensitive asynchronous mode, to support asynchronous (start/stop) protocols;
- 2) protocol sensitive synchronous mode to support synchronous protocols using High-level Data Link Control procedure (HDLC) frame format;
- 3) bit transparent mode to support synchronous protocols.

Only protocol sensitive asynchronous mode shall be used in CTM FP1.

#### A.1.2 Logical links

ITU-T Recommendation V.120 [18] permits to multiplex several terminal adoption connections across a circuit-mode bearer connection. These connections are referred to in ITU-T Recommendation V.120 [18] as "logical links" and are identified by a LLI.

Only LLI 256 (the default one established at the same time of circuit switched bearer connection) and LLI 0 (for in-channel signalling) shall be used by PP and FP CTM FP1 conform.

### A.1.3 Parameter negotiation

ITU-T Recommendation V.120 [18] allows parameter negotiation during the bearer channel establishment in accordance with the procedures described in ITU-T Recommendation Q.931 [13] for circuit mode operation and ITU-T Recommendation Q.933 [14] for frame mode operation.

Parameter negotiation in CTM FP1 shall not be done in this way. During bearer channel establishment negotiation shall be done according to procedure described in [5] subclause 15.2.3.

### A.1.4 Bearer service

ITU-T Recommendation V.120 [18] allows both Frame Mode bearer service and Circuit Mode Bearer service. Only Circuit Mode Bearer service shall be considered in CTM FP1.

### A.1.5 Terminal adoption header

According to ITU-T Recommendation V.120 [18] a logical link may use frames with or without terminal adoption header.

In CTM FP1 shall be used only frames including terminal adaptation header.

### A.1.6 Mode of transmission

ITU-T Recommendation V.120 [18] enables both half duplex and full duplex modes.

In CTM FP1 only full duplex mode shall be used.

---

## A.2 Data Link control and core sublayer

### A.2.1 Signalling protocols

The purpose of signalling procedures described in ITU-T Recommendation V.120 [18] is:

- a) establishment and release of the underlying circuit-mode bearer connection (according to ITU-T Recommendation Q.931 [13]); and
- b) establishment and release of logical links, multiplexed within the circuit-mode bearer connection. Logical link negotiation procedures may be carried out by means of user information messages in ITU-T Recommendation Q.931 [13] call associated temporary signalling connection on the ISDN D-channel, or by means of logical link zero within the bearer channel (in-band).

Differently in CTM FP1 :

- a) establishment and release of the underlying circuit-mode bearer connection shall be done as described in clause 5 NWK layer requirements of the present document; and
- b) establishment and release of logical links shall not be allowed as already stated in subclause A.1.2 Logical links of the present document.

## A.2.2 System parameters

CCITT Recommendation Q.922 [12], referred by ITU-T Recommendation V.120 [18], uses following system parameters:

### Retransmission timer (Timer T200)

It is the timer at the end of which transmission of a frame may be initiated.

### Maximum number of retransmissions (N200)

The retransmission counter (N200) is a system parameter which identifies the maximum number of retransmissions of a frame.

### Maximum number of octets in an Information field (N201)

Defines the maximum number of octet that can be contained in an information field.

### Maximum number of outstanding I frames (k)

The maximum number (k) of sequentially numbered I frames that may be outstanding (that is, unacknowledged) at any given time is also called "maximum window size".

### Timer T203

The idle timer (T203) represents the maximum time allowed without frames being exchanged.

Only the following system parameters may be negotiated:

- T200;
- N201;
- k;
- T203.

System parameters default values that shall be used in CTM FP1 are shown in table A.1.

**Table A.1 System parameter default values**

System Parameter	Default values
Retransmission timer (Timer T200)	300 ms
Maximum number of retransmissions (N200)	64
Maximum number of octets in an Information field (N201)	260
Maximum number of outstanding I frames (k)	32
Timer T203	60 s

---

## A.3 Physical sublayer

According to ITU-T Recommendation V.120 [18] the physical layer protocol shall be as described in Recommendation I.430 or I.431.

In CTP FP1 ITU-T Recommendation V.120 [18] is not an entire level two but just a sublayer, so it shall not rely upon a real physical layer but upon LU1 (Transparent Unprotected Data) DLC.

## Annex B (normative): Interworking

### B.1 Interworking to connection-oriented bearer services

#### B.1.1 Scope

The provisions of this subclause shall apply to interworking to public connection-oriented network services such as PSTN, ISDN or Global System for Mobile communication (GSM). Figure B.1 shows a possible connection scenario.

Interworking to ITU-T V series synchronous modems (e.g. V.34) and ITU-T Recommendation V.110 [17] are examples of this type of applications. The physical implementation of these services and the use of the IWF to other networks (if present) are abstracted from the user.

This annex defines the TAF integral to a Portable Part (PP) and the IWF integral to a Fixed Part (FP) which enable the attachment of serial data applications to a PP and the attachment of connection-oriented serial data transmission network services to a FP.

This annex does not mandate the implementation of a specific interface between the PP and the terminal and the FP and the service/network, but specifies the Air Interface (AI) requirements in order to facilitate interoperability between equipment of different origin.

This annex specifies also interworking conventions for Data Terminal Equipment (DTE)-to-PP interfaces based on ITU-T Recommendation V.24 [15], and corresponding conventions for FP IWUs.

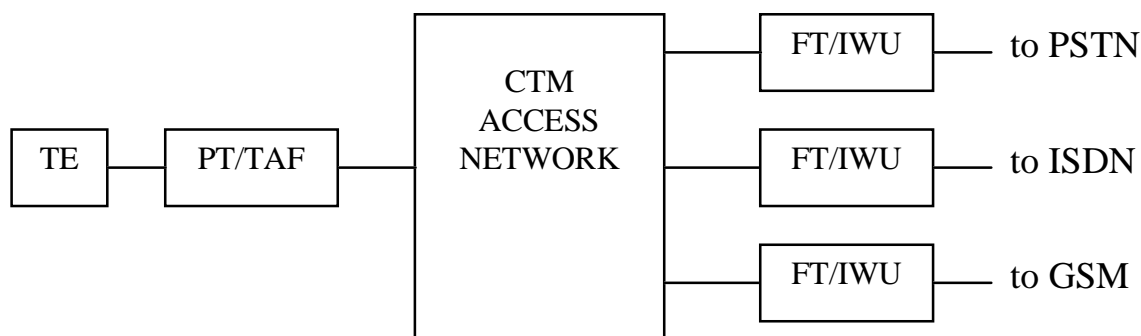

Figure B.1 Connection scenarios

#### B.1.2 Reference configuration

The reference configuration for U-plane and C-plane operation is shown in figure B.2 and figure B.3, respectively.

The serial data transmission service contains a network specific interworking unit using the IWF services to provide interconnection to outside networks such as PSTN, ISDN or Global System for Mobile communication (GSM).

The selection of the appropriate Interworking Unit (IWU) will be determined by the FP/IWF on the basis of information contained in the <<IWU-ATTRIBUTES>> information element signalled in the {CC-SETUP} request message.

In addition where service parameter negotiation is provided, the IWU shall be responsible for interworking the negotiation between the PP and the FP and between the FP and the attached network. Service parameter negotiation is only supported during the call establishment phase.



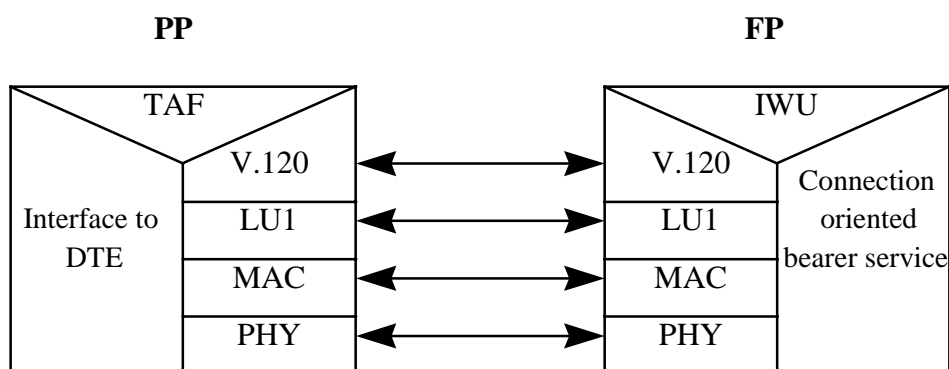

**Figure B.2 Profile reference U-plane configuration showing the interworking to a connection-oriented bearer service**

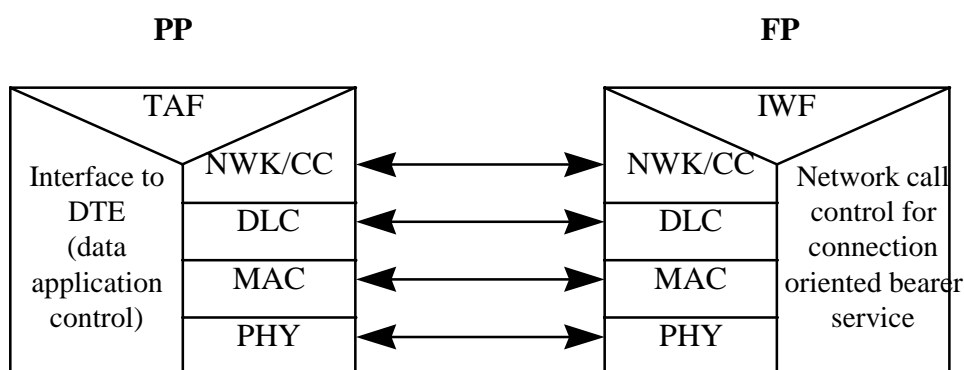

**Figure B.3 Profile reference C-plane configuration showing the interworking to the connection-oriented bearer service**

## B.1.3 Interworking service of DTE using V.24 connection

### B.1.3.1 General

This subclause specifies the interworking of the CTM FP1 services with DTE connected by ITU-T Recommendation V.24 [15] to the PP. This subclause will describe how ITU-T Recommendation V.24 [15] signalling should take place in the TAF.

This subclause (and related subclauses) do not specify or require the physical realization of V.24 capable interface for equipment claiming support of this interworking annex. Instead they require only the logical realization of equivalent functionality with the aim of DECT AI interoperability.

### B.1.3.2 TAF interworking to ITU-T Recommendation V.24

#### B.1.3.2.1 General

The V.24 TAF emulates DCE towards the DTE. The implementation of the V.24 interface is not mandatory in the context of this interworking annex, but if the V.24 interface is implemented physically or logically in the TAF then the provisions of this subclause are mandatory.

#### B.1.3.2.2 V.24 Interchange circuit handling rules

This subclause specifies how shall be handled ITU-T Recommendation V.24 [15] interchange circuits while figures B.4 to B.7 show respectively a PT originated call, a PT terminated call, a release PT initiated and FT initiated.

### **Data Terminal Ready (108/2)**

The circuit 108/2 (DTR) is required to be in the ON state before the PT/TAF may initiate call establishment (manual or automatic). The circuit 108/2 (DTR) may be used to indicate with ON state to the PT/TAF that the DTE is ready to accept an incoming call.

In the active state, the 108/2 (DTR) transition from ON to OFF state shall cause the TAF to release the connection, after an implementation-specific timeout. The PT/TAF shall issue an MNCC-RELEASE-req primitive with Release Reason "User Detached" and send the corresponding {CC-RELEASE} message.

If 108/2(DTR) is OFF, the TAF shall respond to an incoming call with a MNCC-ALERT-req primitive and shall turn ON circuit 125 (RI). If circuit 108/2(DTR) goes ON in this condition, the TAF shall issue an MNCC-CONNECT-req primitive and send the corresponding {CC-CONNECT} message.

### **Data Set Ready (107)**

The status change of circuit 107 (DSR) from OFF to ON by PT/TAF shall indicate to the DTE that network call establishment has been successful, that a far-end modem has been detected and that negotiation to establish a carrier has begun.

The status change of 107 (DSR) from ON to OFF by PT/TAF shall indicate to the DTE that the call has been released. Circuit 107 (DSR) shall be turned OFF when the PT/TAF receives MNCC-REJECT-ind primitive.

### **Data Carrier Detect (109) and Clear To Send (106)**

The status change of circuit 109 (DCD) and 106 (CTS) from OFF to ON indicates to the DTE the successful establishment of a data carrier to the far-end modem, and the availability of service for end-to-end data transfer.

Circuit 109 (DCD) and 106 (CTS) may be turned ON by the PT/TAF, when it receives the first valid ITU-T Recommendation V.120 [18] frame having bit RR ON in its control state octet.

During data transfer circuit 106 (CTS) may be handled to make hardware flow control between DTE and PT/TAF according to the status of local uplink data buffer.

## **B.1.3.2.3 Call establishment signalling handling**

The TAF shall control call establishment by means of the relevant MNCC primitives, in accordance with the procedures of the CAP. Information about the state of call establishment may be transferred by the TAF to the DTE using V.24 control signals or locally defined means. Such information is expected to include notification of the MNCC-CALL\_PROC-ind, MNCC-ALERT-ind and MNCC-CONNECT-ind primitives. In particular, the TAF shall include means to provide notification to the DTE or the user of the MNCC-CONNECT-ind primitive.

Moreover the TAF shall inform DTE about the establishment of an end-to-end data service using V.24 control signals. Such information shall be notified to the PT/TAF by the FT/IWU in the following way. Until the successful establishment of a data carrier between the FT/IWU and the far-end modem the FT/IWU shall send to the PT/TAF ITU-T Recommendation V.120 [18] frames with bit RR zero. When modem setup has ended FT/IWU shall handle bit RR according to ITU-T Recommendation V.120 [18], so it shall send at least a frame containing RR one.

## **B.1.3.3 DECT FP Interworking procedures**

### **B.1.3.3.1 General**

This subclause specifies the interworking procedures for the IWU of the PSTN/ISDN modem service.

### B.1.3.3.2 Call establishment signalling handling

The modem call establishment is directly signalled to IWF via the DECT network layer primitives and procedures standardized herein using the CAP interworking procedures.

If the selected service is an ITU-T V series voice-band modem the signalling to the local fixed network shall be identical to a standard 3,1 kHz audio call establishment up to the point where the FP CC enters the active state. At this point the behaviour of IWF towards the network shall be in accordance with the ITU-T V series modem selected: the modem configuration parameters (e.g. the data rates allowed and the ability of supporting the fall-back mechanism) shall be the ones in the <<IWU-ATTRIBUTES>> IE.

If the selected modem service is an ITU-T Recommendation V.110 [17] ISDN modem the signalling to the local fixed network shall follow the standard ISDN call setup procedures for the ITU-T Recommendation V.110 [17] service. The ITU-T Recommendation V.110 [17] call setup parameters for the ISDN call shall use the appropriate parameters from octets 6 to 8c of the <<IWU-ATTRIBUTES>> IE and shall allocate the remaining ITU-T Recommendation V.110 [17] parameters according to the capabilities of IWF.

The 'Answer' indication from the local fixed network shall be understood when one or more of the following has been detected:

- 1) off-hook for the called party has been detected;
- 2) charging for this call has started;
- 3) a CONNECT message has been received (e.g. from an ISDN network);
- 4) the 2 100 Hz modem tone has been detected.

Depending on the attached local fixed network and the called party it may not be possible to detect any of the above. Under such circumstances the FP IWU is permitted to issue a MNCC-RELEASE-req primitive following a timeout period indicating release reason 'timer expired'.

### B.1.3.3.3 Modem selection

For an outgoing call, the modem type in IWF is selected according to the value of the "modem type" field in <<IWU-ATTRIBUTES>> IE. If this value is not supported by IWF, the supported service negotiation procedures shall be invoked by the IWU. If no acceptable modem can be negotiated, the call is rejected with an MNCC-RELEASE-COM-req primitive with release reason (hex) 05 "Incompatible service".

For an incoming call, a locally determined value of the modem type shall be used by the IWU in the MNCC-SETUP-req primitive and coded in the <<IWU-ATTRIBUTES>> IE. A PP-initiated peer attribute negotiation (ETS 300 175-5 [5], subclause 15.2.5) may be used to modify this value, otherwise the IWF may locally determine a new value after it has received the MNCC-CONNECT-ind primitive and has consequently responded to the incoming call and has agreed the modem type to be used. It shall then communicate this in an MNCC-CONNECT\_ACK-req primitive.

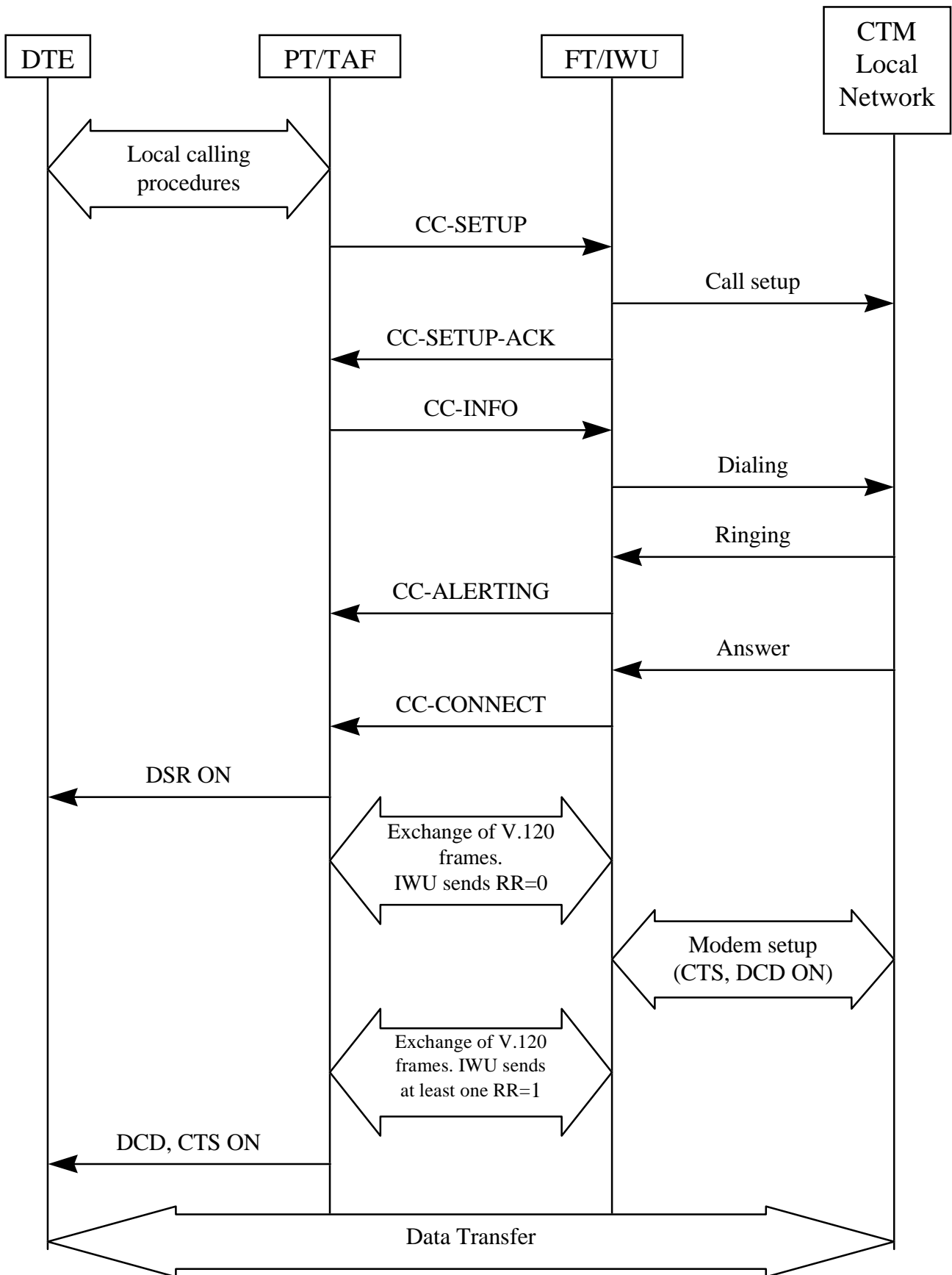

Figure B.4: PT outgoing call

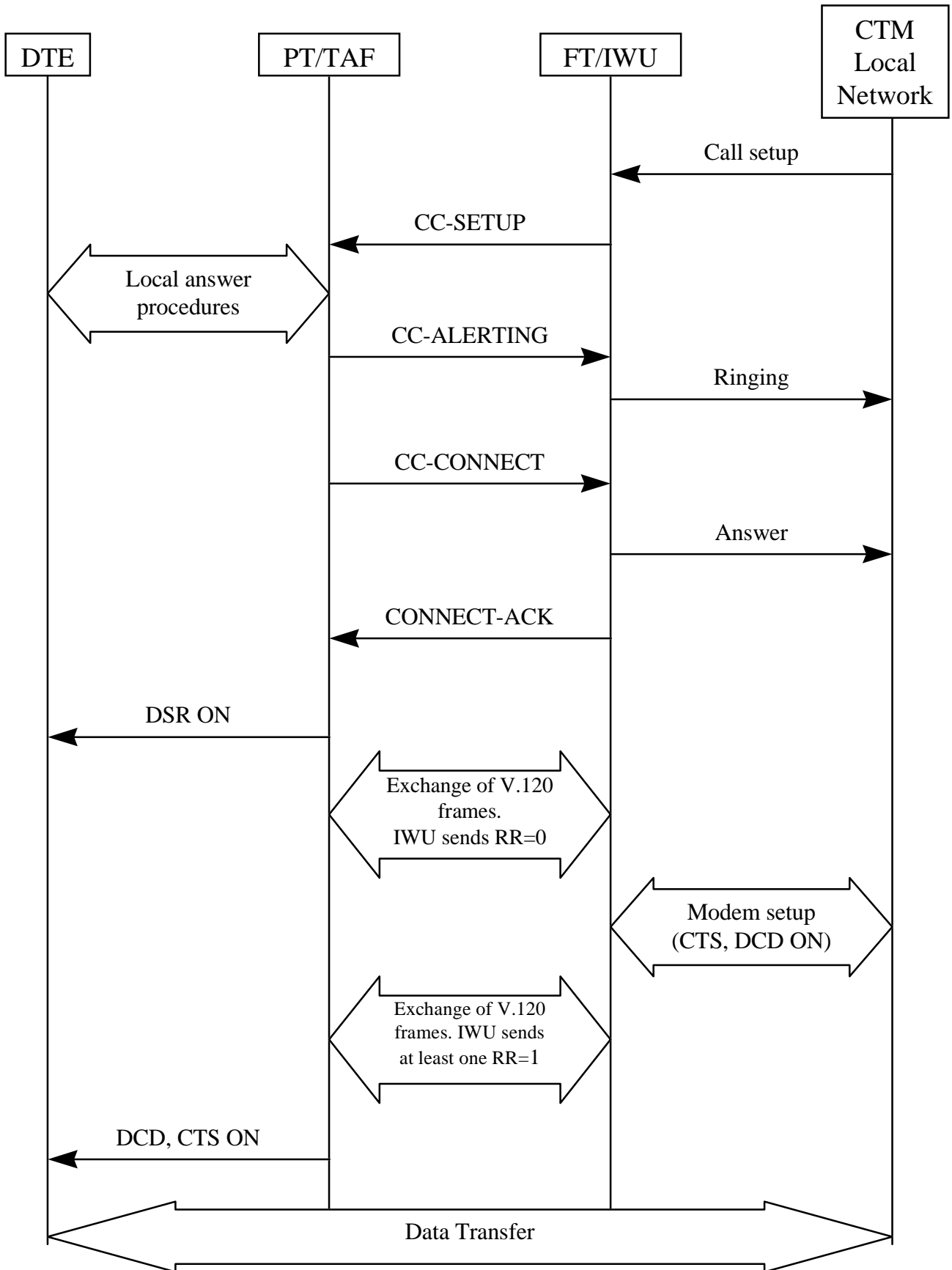

Figure B.5: PP incoming call

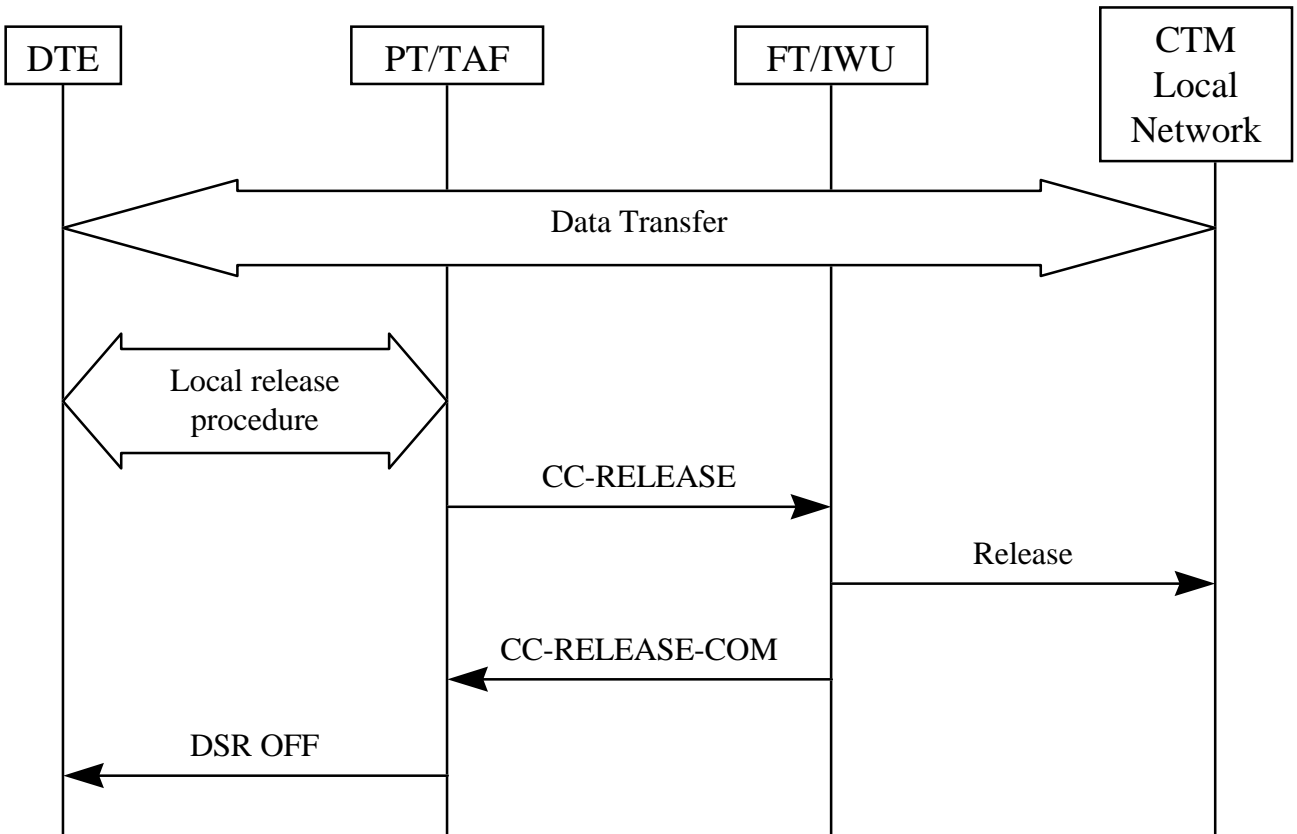

Figure B.6: Release PT initiated

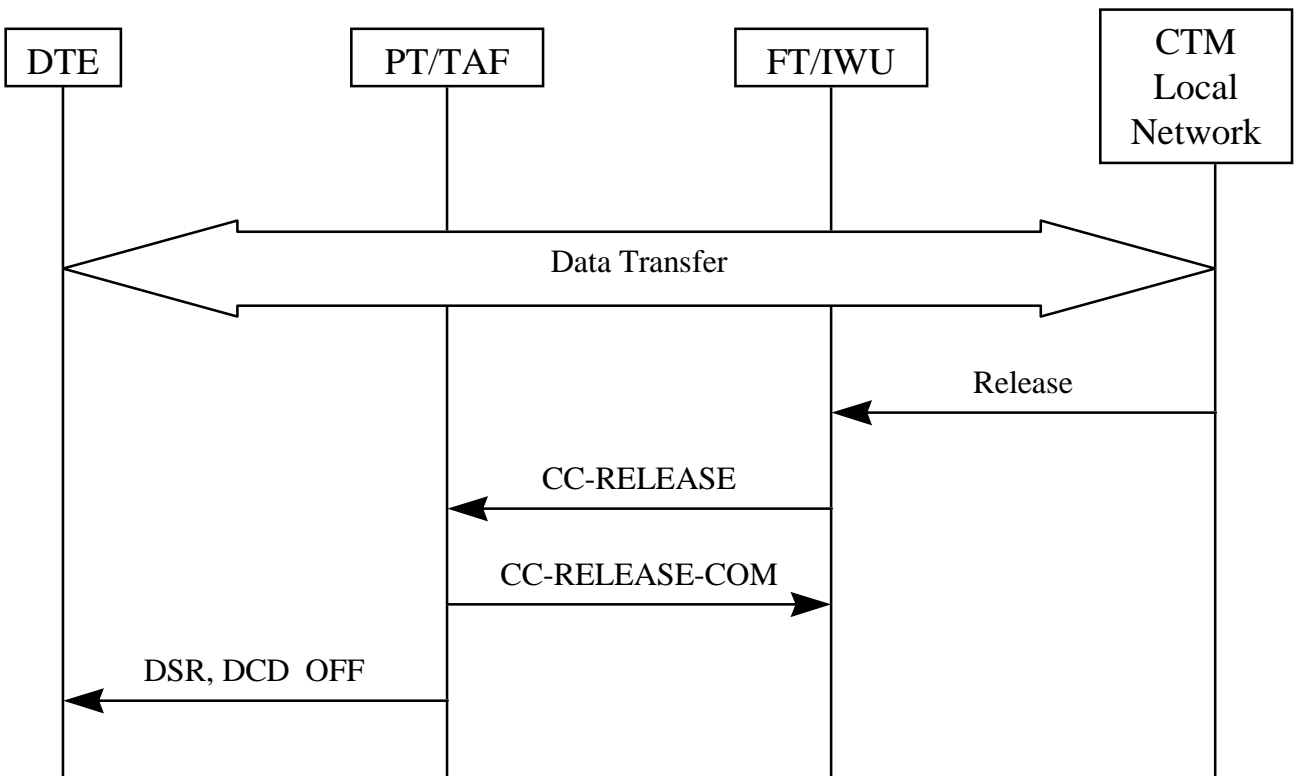

Figure B.7: Release FT initiated

## B.2 <<IWU-ATTRIBUTES>> coding

Bit:	8	7	6	5	4	3	2	1	Octet
0	<<IWU-ATTRIBUTES>>								1
	Length of contents (L)								2
1	Coding standard			Profile					3
1	Negotiation Indicator			Profile subtype					4
0/1	IWU service								5
1	Symmetry		Fbk	Rate Res.		Mfe	Spare		6
1	Stop bits		Data bits		Parity			7	
0/1	Min user data rate Tx								8
0/1	Max user data rate Tx								8a
0/1	Min user data rate Rx								8b
1	Max user data rate Rx								8c

Figure B.8: IWU-ATTRIBUTES information element

### Coding standard (octet 3):

Bits	7 6	Meaning
	0 1	Profile defined coding

### Profile (octet 3):

Bits	5 4 3 2 1	Meaning
	0 1 1 0 1	CTM-FP1 Profile

### Negotiation indicator (octet 4):

Bits	7 6 5	Meaning
		These bits are defined as specified ETS 300 175-5 [5], subclause 7.7.21 Interworking Unit Attributes when the coding standard (octet 3) indicates "Profile defined coding".

### Profile subtype (octet 4):

Bits	4 3 2 1	Meaning
	0 0 0 0	32 kbit/s
		All other values reserved.

**IWU service (octet 5):**

Bits	7 6 5 4 3 2 1	Meaning
	0 0 0 0 0 0 0	Unspecified V.series voice-band modem
	0 0 0 0 0 0 1	V.21
	0 0 0 0 0 1 0	V.22
	0 0 0 0 0 1 1	V.22 bis
	0 0 0 0 1 0 0	V.23
	0 0 0 0 1 0 1	V.26 bis
	0 0 0 0 1 1 0	V.26 ter
	0 0 0 0 1 1 1	V.27
	0 0 0 1 0 0 0	V.27 ter
	0 0 0 1 0 0 1	V.32
	0 0 0 1 0 1 0	V.32 bis
	0 0 0 1 0 1 1	V.34
	0 0 0 1 1 0 0	V.110
	0 0 0 1 1 0 1	V.120
	0 0 0 1 1 1 0	V.24
	0 0 0 1 1 1 1	32 kbit/s unprotected
	0 0 1 1 0 0 0	H.324 via 32 kbit/s (DECT annex)
	0 0 1 1 0 0 1	ATM AAL-1
	1 1 1 1 1 1 1	Escape
		All other values reserved.

**Symmetry (octet 6):**

Bits	7 6	Meaning
	0 0	Asymmetric, full duplex
	0 1	Symmetric, full duplex
		All other values reserved.

**Fbk (octet 6):**

Bits	5	Meaning
	0	Bit rate fall back supported
	1	Bit rate fall back not supported

**Rate Resolution (octet 6):**

Bits	4 3	Meaning
	0 0	$n \times 2,4$ kbit/s
	0 1	$n \times 4$ kbit/s
		All other values reserved.

**Mfe (Multiple frame establishment, octet 6):**

This information element is included for compatibility with ITU-T Recommendation V.120 [18].

Bits	2	Meaning
	0	Multiple frame establishment not supported, only UI frames allowed
	1	Multiple frame establishment supported



**Stop bits (octet 7):**

This information element is included for compatibility with ITU-T Recommendation V.120 [18].

Bits	7 6	Meaning
	0 0	Not used
	0 1	1 bit
	1 0	1.5 bits
	1 1	2 bits

**Data bits (octet 7):**

This information element is included for compatibility with ITU-T Recommendation V.120 [18].

Bits	5 4	Meaning
	0 0	Not used
	0 1	5 bits
	1 0	7 bits
	1 1	8 bits

**Parity (octet 7):**

This information element is included for compatibility with ITU-T Recommendation V.120 [18].

Bits	3 2 1	Meaning
	0 0 0	Odd
	0 1 0	Even
	0 1 1	None
	1 0 0	Forced to 0
	1 0 1	Forced to 1

**Min user data rate Tx (octet 8):**

If the **user data rate resolution** in octet 6 (bits 3-4) indicate ' $n \times 2,4$  kbit/s' then:

Bits	7 6 5 4 3 2 1	Meaning
	0 0 0 0 0 0 0	0 kbit/s
	0 0 0 0 0 0 1	2,4 kbit/s
	0 0 0 0 0 1 0	4,8 kbit/s
	0 0 0 0 0 1 1	7,2 kbit/s
	0 0 0 0 1 0 0	9,6 kbit/s
	0 0 0 0 1 0 1	12 kbit/s
	0 0 0 0 1 1 0	14,4 kbit/s
	0 0 0 0 1 1 1	16,8 kbit/s
	0 0 0 1 0 0 0	19,2 kbit/s
	0 0 0 1 0 0 1	21,6 kbit/s
	0 0 0 1 0 1 0	24 kbit/s
	0 0 0 1 0 1 1	26,4 kbit/s
	0 0 0 1 1 0 0	28,8 kbit/s
	All other values reserved.	

If the **user data rate resolution** in octet 6 (bits 3-4) indicate ' $n \times 4$  kbit/s' then:

Bits	7 6 5 4 3 2 1	Meaning
	0 0 0 0 0 0 0	0 kbit/s
	0 0 0 0 0 0 1	4 kbit/s
	0 0 0 0 0 1 0	8 kbit/s
	0 0 0 0 0 1 1	12 kbit/s
	0 0 0 0 1 0 0	16 kbit/s
	0 0 0 0 1 0 1	20 kbit/s
	0 0 0 0 1 1 0	24 kbit/s
	0 0 0 0 1 1 1	28 kbit/s
	All other values reserved.	

**Max user data rate Tx (octet 8a) (optional):**

This octet is optional. If omitted, the max user data rate Tx shall be interpreted as equal to the rate indicated by octet 8 and octets 8b and 8c shall not be included.

**Bits 7 6 5 4 3 2 1 Meaning**

The coding of these bits is identical to the coding of bits 1-7 of octet 8.

**Min user data rate Rx (octet 8b) (optional):**

This octet is optional. If omitted, the min user data rate Rx shall be interpreted as equal to the rate indicated by octet 8 and octet 8c shall not be included.

**Bits 7 6 5 4 3 2 1 Meaning**

The coding of these bits is identical to the coding of bits 1-7 of octet 8.

**Max user data rate Rx (octet 8c) (optional):**

This octet is optional. If omitted the max user data rate Rx shall be interpreted as equal to the rate indicated by octet 8b.

**Bits 7 6 5 4 3 2 1 Meaning**

The coding of these bits is identical to the coding of bits 1-7 of octet 8.

---

## Bibliography

The following material, though not specifically referenced in the body of the present document (or not publicly available), gives supporting information.

DE/NA-020066: "Cordless Terminal Mobility (CTM); Phase 2+ Feature Package 1 (FP1); 64 and 32 kbit/s Unrestricted Digital Information (UDI)".

EN 300 176-1: "Digital Enhanced Cordless Telecommunications (DECT); Approval test specification; Part 1: Radio".

TBR 22: "Radio Equipment and Systems (RES); Attachment requirements for terminal equipment for Digital Enhanced Cordless Telecommunications (DECT) Generic Access Profile (GAP) applications".

---

## History

<b>Document history</b>			
V0.2.2	March 1999	Public Enquiry	PE 9927: 1999-03-05 to 1999-07-02