

Draft **ETSI EN 302 092-4** V1.1.1 (1999-12)

European Standard (Telecommunications series)

**Broadband Integrated Services Digital Network (B-ISDN) and
Broadband Private Integrated Services Network (B-PISN);
Digital Subscriber Signalling System No. two (DSS2)
and Broadband QSIG (B-QSIG) protocols;
Call control specification in separated call
and bearer control environment;
Part 4: Abstract Test Suite (ATS) and partial Protocol
Implementation eXtra Information for Testing (PIXIT)
proforma specification**



ReferenceDEN/SPAN-05154-4

KeywordsATS, B-ISDN, B-ISUP, B-QSIG, broadband,
control, DSS2, PIXIT, protocol

ETSI

Postal addressF-06921 Sophia Antipolis Cedex - FRANCE

Office address650 Route des Lucioles - Sophia Antipolis
Valbonne - FRANCE
Tel.: +33 4 92 94 42 00 Fax: +33 4 93 65 47 16
Siret N° 348 623 562 00017 - NAF 742 C
Association à but non lucratif enregistrée à la
Sous-Préfecture de Grasse (06) N° 7803/88

Internetsecretariat@etsi.fr
Individual copies of this ETSI deliverable
can be downloaded from
<http://www.etsi.org>
If you find errors in the present document, send your
comment to: editor@etsi.fr

Important notice

This ETSI deliverable may be made available in more than one electronic version or in print. In any case of existing or perceived difference in contents between such versions, the reference version is the Portable Document Format (PDF). In case of dispute, the reference shall be the printing on ETSI printers of the PDF version kept on a specific network drive within ETSI Secretariat.

Copyright Notification

No part may be reproduced except as authorized by written permission.
The copyright and the foregoing restriction extend to reproduction in all media.

© European Telecommunications Standards Institute 1999.
All rights reserved.

Contents

Intellectual Property Rights.....	5
Foreword	5
1 Scope.....	6
2 References.....	6
3 Definitions and abbreviations	7
3.1 Definitions	7
3.2 Abbreviations.....	8
4 Abstract Test Method.....	9
4.1 Description of ATM used	9
4.2 Conventions for test components and PCOs	9
5 Untestable test purposes.....	11
6 ATS to TP map	11
7 PCTR conformance	11
8 PIXIT conformance.....	11
9 ATS Conformance	12
Annex A (normative): Protocol Conformance Test Report (PCTR) proforma.....	13
A.1 Identification summary	13
A.1.1 Protocol conformance test report.....	13
A.1.2 IUT identification	13
A.1.3 Testing environment	13
A.1.4 Limits and reservations	14
A.1.5 Comments	14
A.2 IUT Conformance status	14
A.3 Static conformance summary.....	14
A.4 Dynamic conformance summary.....	15
A.5 Static conformance review report	15
A.6 Test campaign report.....	15
A.7 Observations.....	17
Annex B (normative): Partial PIXIT proforma.....	18
B.1 Identification summary	18
B.2 Abstract test suite summary	18
B.3 Test laboratory	18
B.4 Client (of the Test Laboratory)	19
B.5 SUT	19
B.6 Protocol information	20
B.6.1 Protocol identification.....	20
B.6.2 Release cause values	20
B.6.3 Parameter Values	20
B.6.4 Test management timers	21

Annex C (normative):	Abstract Test Suite (ATS)	22
C1	The TTCN Graphical form (TTCN.GR)	22
C2	The TTCN Machine Processable form (TTCN.MP).....	22
History	23

Intellectual Property Rights

IPRs essential or potentially essential to the present document may have been declared to ETSI. The information pertaining to these essential IPRs, if any, is publicly available for **ETSI members and non-members**, and can be found in SR 000 314: "*Intellectual Property Rights (IPRs); Essential, or potentially Essential, IPRs notified to ETSI in respect of ETSI standards*", which is available from the ETSI Secretariat. Latest updates are available on the ETSI Web server (<http://www.etsi.org/ipr>).

Pursuant to the ETSI IPR Policy, no investigation, including IPR searches, has been carried out by ETSI. No guarantee can be given as to the existence of other IPRs not referenced in SR 000 314 (or the updates on the ETSI Web server) which are, or may be, or may become, essential to the present document.

Foreword

This European Standard (Telecommunications series) has been produced in joint activity by ETSI Technical Committee Signalling Protocol and Switching (SPS) and ECMA TC32 - TG15, and is now submitted for the Public Enquiry phase of the ETSI standards Two-step Approval Procedure.

The present document is part 4 of a multi-part standard covering the Digital Subscriber Signalling System No. 2 (DSS2), Broadband Inter-Exchange Signalling (B-QSIG), and Signalling System No. 7 (SS7) TSS&TP for the Broadband Integrated Services Digital Network (B-ISDN) and Broadband Private Integrated Services Network (B-PISN) Call Control, as described below:

- Part 1: "Protocol specification";
- Part 2: "Protocol Implementation Conformance Statement (PICS) proforma specification";
- Part 3: "Test Suite Structure and Test Purposes (TSS&TP) specification";
- Part 4: "Abstract Test Suite (ATS) and partial Protocol Implementation eXtra Information for Testing (PIXIT) proforma specification".**

Proposed national transposition dates	
Date of latest announcement of this EN (doa):	3 months after ETSI publication
Date of latest publication of new National Standard or endorsement of this EN (dop/e):	6 months after doa
Date of withdrawal of any conflicting National Standard (dow):	6 months after doa

1 Scope

The present document provides the Abstract Test Suite (ATS) and partial Protocol Implementation eXtra Information for Testing (PIXIT) proforma for the Call Control protocol as specified in EN 302 092-1.

This fourth part of EN 302 092 series is applicable to the Call Control protocol at the Q_B , S_B , T_B and co-incident S_B/T_B reference points within, between and at the access to Broadband Private Integrated Services Networks and within, between and at the access to public Broadband Integrated Services Digital Networks.

A further part of this standard specifies the Test Suite Structure and Test Purposes (TSS&TP) related to this ATS and partial PIXIT proforma.

2 References

The following documents contain provisions which, through reference in this text, constitute provisions of the present document.

- References are either specific (identified by date of publication, edition number, version number, etc.) or non-specific.
- For a specific reference, subsequent revisions do not apply.
- For a non-specific reference, the latest version applies.
- A non-specific reference to an ETS shall also be taken to refer to later versions published as an EN with the same number.

- [1] EN 302 092-1 (V1.1.1): "Broadband Integrated Services Digital Network (B-ISDN) and Broadband Private Integrated Services Network (B-PISN); Digital Subscriber Signalling System No. two (DSS2), Broadband Inter-Exchange Signalling (B-QSIG), and Signalling System No.7 (SS7); Call control specification in a separated call and bearer control environment; Part 1: Protocol specification".
- [2] EN 302 092-2 (V1.1.1): "Broadband Integrated Services Digital Network (B-ISDN) and Broadband Private Integrated Services Network (B-PISN); Digital Subscriber Signalling System No. two (DSS2), Broadband Inter-Exchange Signalling (B-QSIG), and Signalling System No.7 (SS7); Call control specification in a separated call and bearer control environment; Part 2: Protocol Implementation Conformance Statement (PICS) proforma specification".
- [3] EN 302 092-3 (V1.1.1): "Broadband Integrated Services Digital Network (B-ISDN) and Broadband Private Integrated Services Network (B-PISN); Digital Subscriber Signalling System No. two (DSS2), Broadband Inter-Exchange Signalling (B-QSIG), and Signalling System No.7 (SS7); Call control specification in a separated call and bearer control environment; Part 3: Test Suite Structure and Test Purposes (TSS&TP) specification".
- [4] ISO/IEC 9646-1: "Information Technology - Open Systems Interconnection - Conformance testing methodology and framework, Part 1: General concepts".
- [5] ISO/IEC 9646-2: "Information Technology - Open Systems Interconnection -Conformance testing methodology and framework, Part 2: Abstract Test Suite Specification".
- [6] ISO/IEC 9646-3: "Information Technology - Open Systems Interconnection -Conformance testing methodology and framework, Part 3: The Tree and Tabular Combined Notation".
- [7] ISO/IEC 9646-4: "Information Technology - Open Systems Interconnection -Conformance testing methodology and framework, Part 4: Test realization".
- [8] ISO/IEC 9646-5: "Information Technology - Open Systems Interconnection -Conformance testing methodology and framework, Part 5: Requirements on test laboratories and clients for the conformance assessment process".

- [9] Void.
- [10] EN 302 092-4: "Broadband Integrated Services Digital Network (B-ISDN); Digital Subscriber Signalling System No. two (DSS2) and Broadband QSIG (B-QSIG) protocols; Call control in separated call and bearer control environment; Part 4: Abstract Test Suite (ATS) and partial Protocol Implementation eXtra Information for Testing (PIXIT) proforma specification".

3 Definitions and abbreviations

3.1 Definitions

For the purposes of the present document, the following terms and definitions apply in addition to the definitions in EN 302 092-1:

Abstract test case: Refer to ISO/IEC 9646-1

Abstract Test Method (ATM): Refer to ISO/IEC 9646-1

Abstract Test Suite (ATS): Refer to ISO/IEC 9646-1

Implementation Under Test (IUT): Refer to ISO/IEC 9646-1

Lower tester (LT): Refer to ISO/IEC 9646-1

Protocol Implementation Conformance Statement (PICS): Refer to ISO/IEC 9646-1

PICS proforma: Refer to ISO/IEC 9646-1

Protocol Implementation eXtra Information for Testing (PIXIT): Refer to ISO/IEC 9646-1

PIXIT proforma: Refer to ISO/IEC 9646-1

Point of Control and Observation (PCO): Refer to ISO/IEC 9646-1

System Under Test (SUT): Refer to ISO/IEC 9646-1

Test Purpose (TP): Refer to ISO/IEC 9646-1

Upper Tester (UT): Refer to ISO/IEC 9646-1

3.2 Abbreviations

For the purposes of the present document, the following abbreviations apply:

APDU	Application Protocol Data Unit
ATM	Abstract Test Method
ATS	Abstract Test Suite
DSS2	Digital Subscriber Signalling System No. two
B-ISDN	Broadband Integrated Services Digital Network
B-PISN	Broadband Private Integrated Services Network
B-QSIG	Broadband Inter-Exchange Signalling System
CC	Call Control
CC0	Call Idle state
CC1	Call Initiated state
CC2	Outgoing Call Proceeding state
CC3	Call Ready state
CC4	Call Present state
CC5	Incoming Call Proceeding state
CC6	Await Call Completion state
CC7	Call Active state
CC8	Call Release Request state
CC9	Call Release Indication state
CM	Co-ordination Message
CP	Co-ordination Point
ExTS	Executable Test Suite
IUT	Implementation Under Test
LT	Lower Tester
MOT	Means Of Testing
MTC	Main Test Component
PCO	Point of Control and Observation
PDU	Protocol Data Unit
PICS	Protocol Implementation Conformance Statement
PIXIT	Protocol Implementation eXtra Information for Testing
PTC	Parallel Test Component
SUT	System Under Test
TCP	Test Co-ordination Procedures
TP	Test Purpose
TTCN	Tree and Tabular Combined Notation
UT	Upper Tester

4 Abstract Test Method

4.1 Description of ATM used

For CC, the protocol defines different roles that a CC entity can play: it can be an end or transit CC entity. In the first case, only one interface is used and in the second case, two interfaces are used for testing purposes.

The requirement for testing the IUT is to focus on the behaviour of the IUT at the Q_B , S_B , T_B and co-incident S_B/T_B reference points within, between and at the access to Broadband Private Integrated Services Networks and within, between and at the access to public Broadband Integrated Services Digital Networks. Thus the IUT is a call control protocol entity at a particular interface and is not the other entities and functions existing in the SUT.

It is possible to specify an ATS based on a Single party (remote) test method for such an IUT. However, it is considered that an ATS based on such an approach is of limited use as the only way to specify IUT generated PDUs is to use the "implicit send" statement. Many users of such an ATS would replace the "implicit send" statements with descriptions of the behaviour at other interfaces.

An ATS based on a multi-party test method is considered to be more useful in that it is closer to how a real test suite would be constructed. Such a test method specifies behaviour at multiple network interfaces. One very important limitation here is that tests are focussed on one particular interface. Thus the test system is made up one Main Test Component (MTC) and one or more Parallel Test Components (PTC), see figure 1.

4.2 Conventions for test components and PCOs

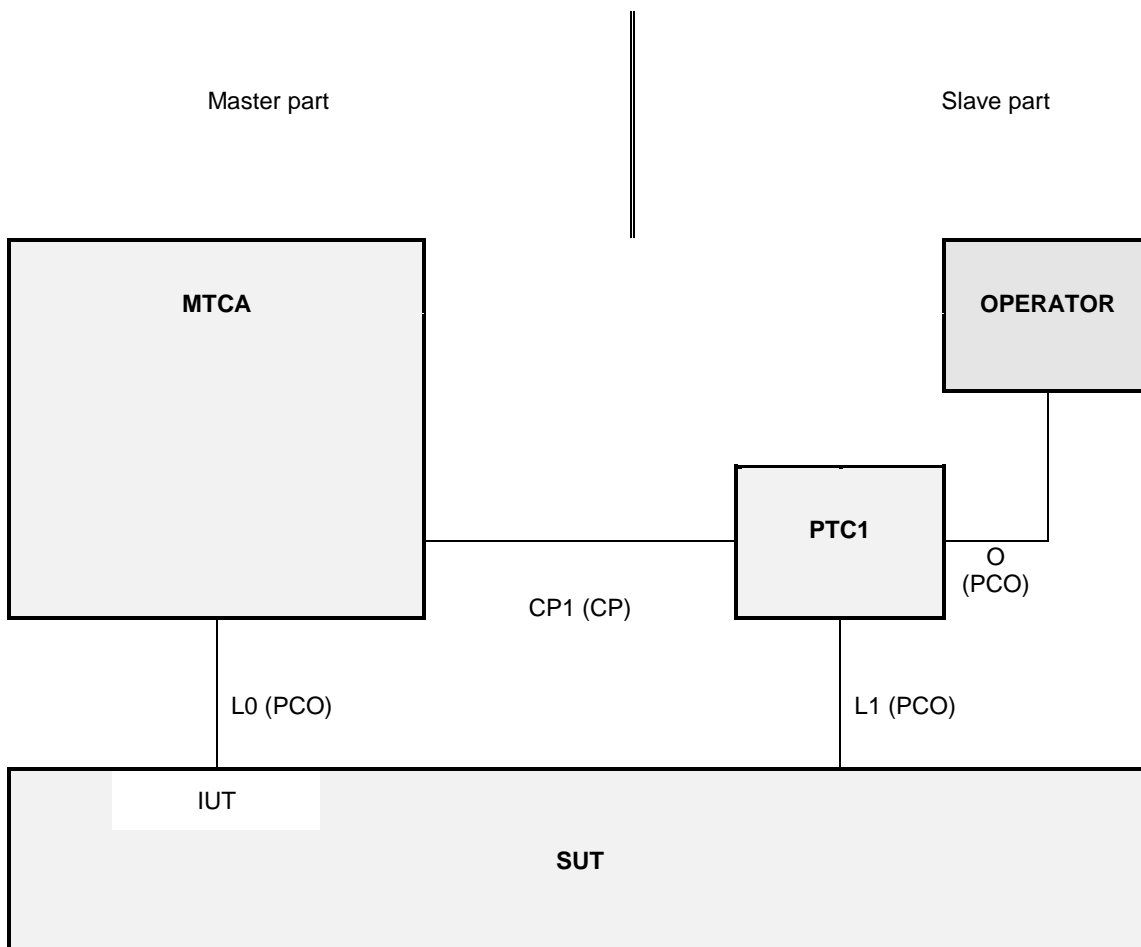

Figure 1: Multi-party test method

In a master/slave arrangement, the MTC is considered to be the master while the PTCs are the slaves. The "slave" testers are only an explicit description of how to deal with the remote interfaces during the testing process, i.e. "how to make the IUT send the required message".

This means, in particular, that the verdict will only be assigned from the protocol aspects observed on *the* interface under test (i.e. by the "master" tester), as it would be observed by a terminal connected to this interface. A failure in the correlation between the protocol at the different interfaces to which the different testers are connected, i.e. in the mechanism of the functional service itself, will not cause a FAIL verdict. For instance, if the IUT fails to send a message on the tested interface after another interface has received the proper stimulus, the verdict will be INCONCLUSIVE.

The MTC MTCA has two functions in this configuration. Firstly, it has the MTC function of controlling the one or more PTCs. Thus it is responsible for starting the PTCs and afterwards co-ordinates activities by exchanging Co-ordination Messages (CM) with the PTCs. Secondly it is responsible for the behaviour of the Lower Tester (LT) at PCO L0.

A combination of the remote and multi-party test methods is applied. As can be seen from figure 1, several PCOs are used.

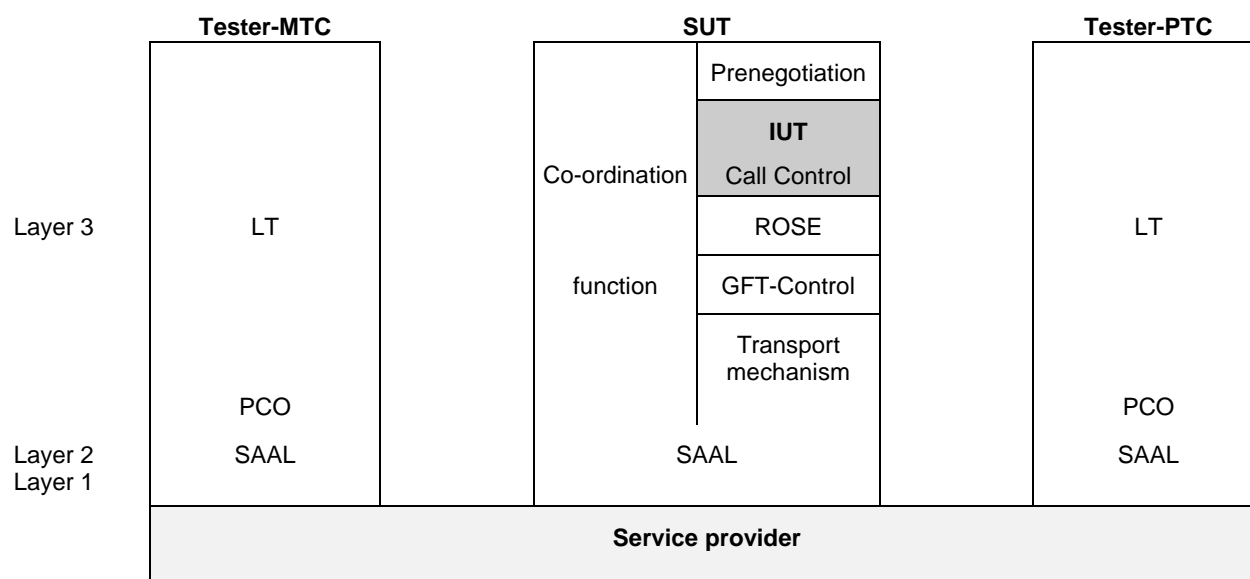

Figure 2: Combination of the remote and multi-party test methods

The MTC PCO is named "L0" ("L" for Lower). The L0 PCO is used to control and observe the behaviour of the IUT and test case verdicts are assigned depending on the behaviour observed at this PCO. The PTC PTC1 uses PCOs L1 and O. These PCOs are used to control and, in a limited way, observe the behaviour of the network equipment at interface other than the one under test. No verdicts are assigned at this PCO. The L1 PCO is only used for transit CC entity.

ISO/IEC 9646-2 [6] allows the informal expression of Test Co-ordination Procedures (TCP) between the System Under Test (SUT) upper layer(s) and the Lower Tester (LT). In the ATS contained in annex C, TCP is achieved by use of a second "informal" PCO, called "O" (for Operator). This PCO is used to specify control but not observation above the IUT and consequently, events at this PCO are never used to generate test case verdicts. The use of this O PCO is regarded as a preferred alternative to the use of the implicit send event, in that it allows the ATS to specify in a clear and meaningful way what actions are required to be performed on the IUT. As an alternative of L1, the O PCO is used for an end CC entity.

As stated in a previous paragraph, the non-receipt of network generated messages at L0, which are stimulated by events at the L1, will result in INCONCLUSIVE rather than FAIL verdicts being assigned.

In test cases which verify that the IUT rejects invalid or unacceptable APDUs, no PTC is activated at all, as these procedures are considered local to the access between IUT and MTC.

5 Untestable test purposes

There are no untestable test purposes associated with this ATS.

6 ATS to TP map

The identifiers used for the TPs are reused as test case names. Thus there is a straightforward one-to-one mapping.

7 PCTR conformance

A test laboratory, when requested by a client to produce a PCTR, is required, as specified in ISO/IEC 9646-5, to produce a PCTR conformant with the PCTR template given in annex B of ISO/IEC 9646-5.

Furthermore, a test laboratory, offering testing for the ATS specification contained in annex C, when requested by a client to produce a PCTR, is required to produce a PCTR conformant with the PCTR proforma contained in annex A of the present document.

A PCTR which conforms to this PCTR proforma specification shall preserve the content and ordering of the clauses contained in annex A. Clause A.6 of the PCTR may contain additional columns. If included, these shall be placed to the right of the existing columns. Text in italics may be retained by the test laboratory.

8 PIXIT conformance

A test realizer, producing an executable test suite for the Abstract Test Suite (ATS) specification contained in annex C, is required, as specified in ISO/IEC 9646-4, to produce an augmented partial PIXIT proforma conformant with this partial PIXIT proforma specification.

An augmented partial PIXIT proforma which conforms to this partial PIXIT proforma specification shall, as a minimum, have contents which are technically equivalent to annex B. The augmented partial PIXIT proforma may contain additional questions that need to be answered in order to prepare the Means Of Testing (MOT) for a particular Implementation Under Test (IUT).

A test laboratory, offering testing for the ATS specification contained in annex C, is required, as specified in ISO/IEC 9646-5, to further augment the augmented partial PIXIT proforma to produce a PIXIT proforma conformant with this partial PIXIT proforma specification.

A PIXIT proforma which conforms to this partial PIXIT proforma specification shall, as a minimum, have contents which are technically equivalent to annex B. The PIXIT proforma may contain additional questions that need to be answered in order to prepare the test laboratory for a particular IUT.

9 ATS Conformance

The test realizer, producing a Means Of Testing (MOT) and Executable Test Suite (ExTS) for this Abstract Test Suite (ATS) specification, shall comply with the requirements of ISO/IEC 9646-4. In particular, these concern the realization of an Executable Test Suite (ExTS) based on each ATS. The test realizer shall provide a statement of conformance of the MOT to this ATS specification.

An ExTS which conforms to this ATS specification shall contain test groups and test cases which are technically equivalent to those contained in the ATS in annex C. All sequences of test events comprising an abstract test case shall be capable of being realized in the executable test case. Any further checking which the test system might be capable of performing is outside the scope of this ATS specification and shall not contribute to the verdict assignment for each test case.

Test laboratories running conformance test services using this ATS shall comply with ISO/IEC 9646-5.

A test laboratory which claims to conform to this ATS specification shall use an MOT which conforms to this ATS.

Annex A (normative): Protocol Conformance Test Report (PCTR) proforma

Notwithstanding the provisions of the copyright clause related to the text of the present document, ETSI grants that users of the present document may freely reproduce the PCTR proforma in this annex so that it can be used for its intended purposes and may further publish the completed PCTR.

A.1 Identification summary

A.1.1 Protocol conformance test report

PCTR number:	
PCTR Date:	
Corresponding SCTR number:	
Corresponding SCTR date:	
Test Laboratory identification:	
Test Laboratory Manager:	
Signature:	

A.1.2 IUT identification

Name:	
Version:	
Protocol specification:	EN 302 092-1
PICS:	EN 302 092-2
Previous PCTRs (if any)	

A.1.3 Testing environment

PIXIT Reference number:	
ATS Specification:	EN 302 092-4
Abstract Test Method:	Remote test method (see ISO/IEC 9646-2)
Means of Testing identification:	
Dates of testing:	
Conformance Log reference(s):	
Retention Date for Log reference(s):	

A.1.4 Limits and reservations

Additional information relevant to the technical contents or further use of the test report, or to the rights and obligations of the test laboratory and the client, may be given here. Such information may include restriction on the publication of the report.

A.1.5 Comments

Additional comments may be given by either the client or the test laboratory on any of the contents of the PCTR, for example, to note disagreement between the two parties.

A.2 IUT Conformance status

This IUT has or has not been shown by conformance assessment to be non-conforming to the specified protocol specification.

Strike the appropriate words in this sentence. If the PICS for this IUT is consistent with the static conformance requirements (as specified in clause A.3 of this report) and there are no "FAIL" verdicts to be recorded (in clause A.6) strike the words "has or", otherwise strike the words "or has not".

A.3 Static conformance summary

The PICS for this IUT is or is not consistent with the static conformance requirements in the specified protocol.

Strike the appropriate words in this sentence.

A.4 Dynamic conformance summary

The test campaign did or did not reveal errors in the IUT.

Strike the appropriate words in this sentence. If there are no "FAIL" verdicts to be recorded (in clause A.6 of this report) strike the words "did or", otherwise strike the words "or did not".

Summary of the results of groups of tests:

A.5 Static conformance review report

If clause A.3 indicates non-conformance, this subclause itemizes the mismatches between the PICS and the static conformance requirements of the specified protocol specification.

A.6 Test campaign report

ATS Reference	Selected ? (Y/N)	Run ? (Y/N)	Verdict	Observations
CC_111_01				
CC_111_02				
CC_112_01				
CC_112_02				
CC_112_03				
CC_112_04				
CC_112_05				
CC_112_06				
CC_112_07				
CC_112_08				
CC_112_09				
CC_112_10				
CC_112_11				
CC_112_12				
CC_112_13				
CC_112_14				
CC_112_15				
CC_112_16				
CC_113_01				
CC_113_02				
CC_121_01				
CC_121_02				

ATS Reference	Selected ? (Y/N)	Run ? (Y/N)	Verdict	Observations
CC_121_03				
CC_121_04				
CC_121_05				
CC_121_06				
CC_121_07				
CC_121_08				
CC_121_09				
CC_121_10				
CC_121_11				
CC_121_12				
CC_121_13				
CC_121_14				
CC_121_15				
CC_121_16				
CC_121_17				
CC_121_18				
CC_121_19				
CC_121_20				
CC_121_21				
CC_121_22				
CC_121_23				
CC_121_24				
CC_121_25				
CC_121_26				
CC_121_27				
CC_121_28				
CC_121_29				
CC_121_30				
CC_121_31				
CC_121_32				
CC_121_33				
CC_122_01				
CC_122_02				
CC_122_03				
CC_122_04				
CC_122_05				
CC_122_06				
CC_122_07				
CC_122_08				
CC_122_09				
CC_122_10				
CC_122_11				
CC_122_12				
CC_122_13				
CC_122_14				
CC_122_15				
CC_122_16				
CC_211_01				
CC_211_02				
CC_211_03				
CC_211_04				
CC_211_05				
CC_211_06				
CC_211_07				
CC_211_08				
CC_222_01				
CC_222_02				
CC_222_03				
CC_222_04				
CC_222_05				
CC_311_01				
CC_311_02				
CC_311_03				

ATS Reference	Selected ? (Y/N)	Run ? (Y/N)	Verdict	Observations
CC_311_04				
CC_311_05				
CC_311_06a				
CC_311_06b				
CC_311_07				
CC_311_08				
CC_311_09				
CC_311_10				
CC_311_11				
CC_311_12				
CC_311_13				
CC_311_14				
CC_311_15a				
CC_311_15b				
CC_312_01				
CC_321_01				
CC_321_02				
CC_321_03				
CC_321_04				
CC_321_05				
CC_321_06a				
CC_321_06b				
CC_322_01a				
CC_322_01b				
CC_322_03a				
CC_322_03b				
CC_322_04a				
CC_322_04b				
CC_322_05a				
CC_322_05b				
CC_322_06a				
CC_322_06b				
CC_322_07a				
CC_322_07b				
CC_322_08a				
CC_322_08b				

A.7 Observations

Additional information relevant to the technical content of the PCTR are given here.

Annex B (normative): Partial PIXIT proforma

Notwithstanding the provisions of the copyright clause related to the text of the present document, ETSI grants that users of the present document may freely reproduce the PIXIT proforma in this annex so that it can be used for its intended purposes and may further publish the completed PIXIT.

B.1 Identification summary

PIXIT Number:

Test Laboratory Name:

Date of Issue:

Issued to:

B.2 Abstract test suite summary

Protocol Specification: EN 302 092-1

ATS Specification: EN 302 092-4

Abstract Test Method: Remote test method (see ISO/IEC 9646-2)

B.3 Test laboratory

Test Laboratory Identification:

Accreditation status of the test service:

Accreditation reference:

Test Laboratory Manager:

Test Laboratory contact:

Means of Testing:

Test Laboratory instructions for Completion:

B.4 Client (of the Test Laboratory)

Client Identification:

Client Test manager:

Client contact:

Test Facilities required:

B.5 SUT

Name:

Version:

SCS Reference:

Machine configuration:

Operating System Identification:

IUT Identification:

PICS (all layers):

Limitations of the SUT:

Environmental Conditions:

B.6 Protocol information

B.6.1 Protocol identification

Specification reference: EN 302 092-1

Protocol Version:

PICS Reference: EN 302 092-2

B.6.2 Release cause values

Table B.1: Release cause values

Item	Does the IUT support the sending a CallRelease Invoke APDU indicating ...	Supported Y/N
1.1	normalCallClearing?	
1.2	callDescriptionNotAccepted?	
1.3	temporaryFailure?	

B.6.3 Parameter Values

Table B.2: Parameter values

Item	Parameter values Give a value for...	Value
Call description		
2.1	the bearer establishment address of the preceding side	
2.2	the bearer establishment address of the succeeding side	
2.3	a valid bearer ID	
2.4	the preceding side party EP address.	
2.5	the succeeding side party EP address.	
2.6	a callDescription that will not be accepted by the IUT (note)	
2.7	a callDescription that indicates an unallocated number (note)	
2.8	a callDescription that contains an incomplete address (note)	
Protocol discriminator		
2.9	protocol discriminator to be used in the message header of the transport messages	
2.10	protocol profile to be used in the Facility information element	
NOTE: These fields need only be completed, if the specified coding exists.		

B.6.4 Test management timers

Table B.3: Timer values

Item	Timer Give a value for the timer that is used ...	Value (in seconds)
3.1	to wait for the IUT to respond to a stimulus sent by the tester (TAC).	
3.2	to control that the IUT does not respond to a stimulus sent by the tester (TNOAC).	
3.3	to wait for the test operator to perform an implicit send action or to wait for a PTC to react (TWAIT).	
3.4	as T701 (default 162 seconds)	
3.5	as T703 (default 3 - 15 seconds)	
3.6	as T708 (default 30 seconds)	
3.7	as T710 (default 30 seconds)	
<p>NOTE: The IUT provider may fill in a value range rather than a fixed value for the test management timers. During test execution the test laboratory will choose specific values for the timers dependant on the means of testing used. These specific values may even be beyond the range given by the IUT provider, if this is necessary for achieving satisfactory test results.</p>		

Annex C (normative): *Abstract Test Suite (ATS)*

This ATS has been produced using the Tree and Tabular Combined Notation (TTCN) according to ISO/IEC 9646-3 [6].

The ATS was developed on a separate TTCN software tool and therefore the TTCN tables are not completely referenced in the table of contents. The ATS itself contains a test suite overview part which provides additional information and references.

C1 The TTCN Graphical form (TTCN.GR)

The TTCN.GR representation of this ATS is contained in an Adobe Portable Document Format™ file (TD045b.PDF contained in archive jdd00ico.ZIP) which accompanies the present document.

C2 The TTCN Machine Processable form (TTCN.MP)

The TTCN.MP representation corresponding to this ATS is contained in an ASCII file (TD044b.MP contained in archive jdd00ico.ZIP) which accompanies the present document.

History

Document history			
V1.1.1	December 1999	Public Enquiry	PE 200016: 1999-12-22 to 2000-04-21