

Final draft **ETSI EN 302 077-1** V1.1.1 (2004-11)

---

*European Standard (Telecommunications series)*

**Electromagnetic compatibility  
and Radio spectrum Matters (ERM);  
Transmitting equipment for the  
Terrestrial - Digital Audio Broadcasting (T-DAB) service;  
Part 1: Technical characteristics and test methods**

---



---

Reference

DEN/ERM-TG17WG2-002-1

---

Keywords

audio, broadcasting, DAB, digital, radio, terrestrial

**ETSI**

650 Route des Lucioles  
F-06921 Sophia Antipolis Cedex - FRANCE

Tel.: +33 4 92 94 42 00 Fax: +33 4 93 65 47 16

Siret N° 348 623 562 00017 - NAF 742 C  
Association à but non lucratif enregistrée à la  
Sous-Préfecture de Grasse (06) N° 7803/88

---

**Important notice**

Individual copies of the present document can be downloaded from:

<http://www.etsi.org>

The present document may be made available in more than one electronic version or in print. In any case of existing or perceived difference in contents between such versions, the reference version is the Portable Document Format (PDF). In case of dispute, the reference shall be the printing on ETSI printers of the PDF version kept on a specific network drive within ETSI Secretariat.

Users of the present document should be aware that the document may be subject to revision or change of status. Information on the current status of this and other ETSI documents is available at

<http://portal.etsi.org/tb/status/status.asp>

If you find errors in the present document, please send your comment to one of the following services:

[http://portal.etsi.org/chaicor/ETSI\\_support.asp](http://portal.etsi.org/chaicor/ETSI_support.asp)

---

**Copyright Notification**

No part may be reproduced except as authorized by written permission.  
The copyright and the foregoing restriction extend to reproduction in all media.

© European Telecommunications Standards Institute 2004.  
All rights reserved.

**DECT™**, **PLUGTESTS™** and **UMTS™** are Trade Marks of ETSI registered for the benefit of its Members.  
**TIPHON™** and the **TIPHON logo** are Trade Marks currently being registered by ETSI for the benefit of its Members.  
**3GPP™** is a Trade Mark of ETSI registered for the benefit of its Members and of the 3GPP Organizational Partners.

# Contents

Intellectual Property Rights .....	5
Foreword.....	5
Introduction .....	5
1 Scope .....	6
2 References .....	6
3 Definitions, symbols and abbreviations .....	7
3.1 Definitions .....	7
3.2 Symbols.....	8
3.3 Abbreviations .....	8
4 Technical requirements specifications .....	9
4.1 Environmental profile.....	9
4.2 Transmitter output characteristics .....	9
4.2.1 Rated output power.....	9
4.2.1.1 Definition .....	9
4.2.1.2 Method of measurement.....	9
4.2.1.2.1 Initial conditions .....	9
4.2.1.2.2 Procedure.....	9
4.2.1.2.3 Test requirements .....	10
4.2.1.3 Limit.....	10
4.2.2 Frequency stability.....	10
4.2.2.1 Definition .....	10
4.2.2.2 Method of measurement.....	10
4.2.2.2.1 Initial conditions .....	10
4.2.2.2.2 Procedure.....	10
4.2.2.2.3 Test requirements .....	10
4.2.2.3 Limit.....	11
4.2.3 Crest factor.....	11
4.2.3.1 Definition .....	11
4.2.3.2 Method of measurement.....	11
4.2.3.2.1 Initial conditions .....	11
4.2.3.2.2 Procedure.....	11
4.2.3.2.3 Test requirements .....	11
4.2.3.3 Limit.....	12
4.3 Digital signal processing .....	12
4.3.1 Signal delay of T-DAB transmitters .....	12
4.3.1.1 Definition .....	12
4.3.1.2 Method of measurement.....	12
4.3.1.2.1 Initial conditions .....	12
4.3.1.2.2 Procedure.....	12
4.3.1.2.3 Test requirements .....	12
4.3.1.3 Limit.....	12
4.3.2 Behaviour in case of erroneous ETI signal .....	12
4.3.2.1 Definition .....	12
4.3.2.2 Method of measurement.....	12
4.3.2.2.1 Initial conditions .....	12
4.3.2.2.2 Procedure.....	13
4.3.2.2.3 Test requirements .....	13
4.3.2.3 Limit.....	13
4.3.3 BER-Performance degradation .....	13
4.3.3.1 Definition .....	13
4.3.3.2 Method of measurement.....	13
4.3.3.2.1 Initial conditions .....	13
4.3.3.2.2 Procedure.....	13

4.3.3.2.3	Test requirements .....	14
4.3.3.3	Limit.....	14
4.4	Antenna port measurements .....	14
4.4.1	Spurious emissions .....	14
4.4.1.1	Definition .....	14
4.4.1.2	Method of measurement (essential test suite) .....	14
4.4.1.2.1	Initial conditions .....	14
4.4.1.2.2	Procedure.....	15
4.4.1.2.3	Test requirements .....	15
4.4.1.3	Limit.....	15
4.4.2	Out-of-band emissions.....	17
4.4.2.1	Definition .....	17
4.4.2.2	Method of measurement (essential test suite) .....	17
4.4.2.2.1	Initial conditions .....	17
4.4.2.2.2	Procedure.....	17
4.4.2.2.3	Test requirements .....	17
4.4.2.3	Limit.....	17
4.5	Enclosure port measurements (radiated emissions).....	21
4.5.1	Cabinet radiation.....	21
4.5.1.1	Definition .....	21
4.5.1.2	Method of measurement (essential test suite) .....	21
4.5.1.2.1	Initial conditions .....	21
4.5.1.2.2	Procedure.....	21
4.5.1.2.3	Test requirements .....	21
4.5.1.3	Limit.....	22
4.6	Measurement uncertainties .....	23
<b>Annex A (normative): General measuring arrangements .....</b>		<b>24</b>
A.1	Testing arrangements for antenna port measurements .....	24
A.1.1	Spurious emissions .....	24
A.1.2	Out-of-band emissions .....	25
A.1.3	Test frequency range .....	25
A.1.4	Test modulating signal .....	26
A.2	Testing arrangements for enclosure port (radiated emissions) measurements .....	26
<b>Annex B (informative): Typical COFDM measuring arrangements.....</b>		<b>27</b>
B.1	ETI errors .....	27
B.2	Bit Error performance measurement .....	27
B.2.1	Test procedure .....	27
<b>Annex C (informative): Measurement of the overall delay of a T-DAB transmitter .....</b>		<b>29</b>
<b>Annex D (informative): Delay type and delay management.....</b>		<b>31</b>
<b>Annex E (informative): Spectrum measurements .....</b>		<b>32</b>
<b>Annex F (informative): Bibliography.....</b>		<b>33</b>
History .....		34

---

## Intellectual Property Rights

IPRs essential or potentially essential to the present document may have been declared to ETSI. The information pertaining to these essential IPRs, if any, is publicly available for **ETSI members and non-members**, and can be found in ETSI SR 000 314: "*Intellectual Property Rights (IPRs); Essential, or potentially Essential, IPRs notified to ETSI in respect of ETSI standards*", which is available from the ETSI Secretariat. Latest updates are available on the ETSI Web server (<http://webapp.etsi.org/IPR/home.asp>).

Pursuant to the ETSI IPR Policy, no investigation, including IPR searches, has been carried out by ETSI. No guarantee can be given as to the existence of other IPRs not referenced in ETSI SR 000 314 (or the updates on the ETSI Web server) which are, or may be, or may become, essential to the present document.

---

## Foreword

This European Standard (Telecommunications series) has been produced by ETSI Technical Committee Electromagnetic compatibility and Radio spectrum Matters (ERM), and is now submitted for the Vote phase of the ETSI standards Two-step Approval Procedure.

The present document is part 1 of a multi-part deliverable covering the Electromagnetic compatibility and Radio spectrum Matters (ERM); Transmitting equipment for the Terrestrial - Digital Audio Broadcasting (T-DAB) service, as identified below:

**Part 1: "Technical characteristics and test methods";**

Part 2: "Harmonized EN under article 3.2 of R&TTE Directive".

<b>Proposed national transposition dates</b>	
Date of latest announcement of this EN (doa):	3 months after ETSI publication
Date of latest publication of new National Standard or endorsement of this EN (dop/e):	6 months after doa
Date of withdrawal of any conflicting National Standard (dow):	6 months after doa

---

## Introduction

The present document covers a set of non mandatory technical parameters that are considered to be the minimum requirement for the design and operation of a T-DAB sound broadcasting service.

Other documents directly associated with the present document:

- EN 302 077-2 [1];
- EN 301 489-11 [2].

---

# 1 Scope

The present document applies to the following radio telecommunications terminal equipment types:

- Digital Audio Broadcast - Terrestrial equipment used in the sound broadcasting service.

NOTE: At the time the present document was drafted, the following bands were allocated to T-DAB (Wiesbaden agreement, Maastricht agreement (see bibliography)):

- 47 MHz to 68 MHz;
- 174 MHz to 240 MHz;
- 1 452 MHz to 1 492 MHz.

---

# 2 References

The following documents contain provisions which, through reference in this text, constitute provisions of the present document.

- References are either specific (identified by date of publication and/or edition number or version number) or non-specific.
- For a specific reference, subsequent revisions do not apply.
- For a non-specific reference, the latest version applies.

Referenced documents which are not found to be publicly available in the expected location might be found at <http://docbox.etsi.org/Reference>.

- [1] ETSI EN 302 077-2: "Electromagnetic compatibility and Radio spectrum Matters (ERM); Transmitting equipment for the Terrestrial - Digital Audio Broadcasting (T-DAB) service; Part 2: Harmonized EN under article 3.2 of the R&TTE Directive".
- [2] ETSI EN 301 489-11: "Electromagnetic compatibility and Radio spectrum Matters (ERM); ElectroMagnetic Compatibility (EMC) standard for radio equipment and services; Part 11: Specific conditions for terrestrial sound broadcasting service transmitters".
- [3] ETSI ETS 300 799: "Digital Audio Broadcasting (DAB); Distribution interfaces; Ensemble Transport Interface (ETI)".
- [4] CENELEC EN 55022: "Information technology equipment - Radio disturbance characteristics - Limits and methods of measurement".
- [5] CENELEC EN 55011: "Industrial, scientific and medical (ISM) radio-frequency equipment - Radio disturbance characteristics - Limits and methods of measurement".
- [6] IEC 60489-1 amendment 2: "Methods of measurement for radio equipment used in the mobile services. Part 1: General definitions and standard conditions of measurement".
- [7] ETSI TR 100 028 (all parts): "Electromagnetic compatibility and Radio spectrum Matters (ERM); Uncertainties in the measurement of mobile radio equipment characteristics".

---

## 3 Definitions, symbols and abbreviations

### 3.1 Definitions

For the purposes of the present document, the following terms and definitions apply:

**antenna port:** port of an apparatus which is designed, in normal operation, to be connected to an antenna using coaxial cable

**broadcasting service:** radiocommunication service in which the transmissions are intended for direct reception by the general public

NOTE: This service may include sound transmissions, television transmissions or other types of transmission.

**cabinet radiation:** radiation from an enclosure containing, equipment, excluding radiation from connected antennas or cables

**class of emission:** set of characteristics of an emission, designated by standard symbols, e.g. type of modulation of the main carrier, modulating signal, type of information to be transmitted, and also, if appropriate, any additional signal characteristics

**dBc:** decibels relative to the unmodulated carrier power of the emission

NOTE: In the cases which do not have a carrier, for example in some digital modulation schemes where the carrier is not accessible for measurement, the reference level equivalent to dBc is decibels relative to the mean power P.

**enclosure port:** physical boundary of the apparatus through which electromagnetic fields may radiate or impinge

NOTE: In the case of integral antenna equipment, this port is inseparable from the antenna port.

**environmental profile:** range of environmental conditions under which equipment within the scope of EN 302 077-1 is required to comply with the provisions of EN 302 077-1

**exclusion band:** band of radio frequencies where no measurements are made

**harmonic:** component of order greater than 1 of the Fourier series of a periodic quantity

**harmonic number:** integral number given by the ratio of the frequency of a harmonic to the fundamental frequency (2<sup>nd</sup> harmonic = 2 x fundamental frequency)

**intermodulation products:** unwanted frequencies resulting from intermodulation between carriers or harmonics of emission, or between any oscillations generated to produce the carrier

**L-band:** for the purpose of these document L-band is defined as the frequency range from 1 452 MHz to 1 492 MHz

**mean power:** average power supplied to the antenna port by a transmitter during an interval of time sufficiently long compared with the lowest frequency encountered in the modulation envelope taken under normal operating conditions

**necessary bandwidth:** for a given class of emission, the width of the frequency band which is sufficient to ensure the transmission of information at the rate and with the quality required under specified conditions

**out-of-band emissions:** emission on a frequency or frequencies immediately outside the necessary bandwidth which results from the modulation process, but excluding spurious emissions

**rated output power:** power that the transmitter or transposer shall deliver at its output under specified conditions of operation

**reference bandwidth:** bandwidth in which the emission level is specified

**RMS power:** the apparent power of an AC power that is calculated by multiplying root-mean-square (rms) current by the root mean square voltage

NOTE 1: In a purely resistive circuit this is held to be the equivalent heating effect of a DC power and can be deemed to be true power. In a circuit that consists of reactance as well as resistance the apparent power is greater than the true power (the vector difference between true power and apparent power is called reactive power).

$$\text{True Power} = V_{\text{rms}} \times (I_{\text{rms}} \Delta \cos \emptyset)$$

Where  $\Delta \cos \emptyset$  is the phase difference between voltage and current introduced by the reactance of the load.

NOTE 2: From the above definition it becomes clear that unless any measuring system can be completely devoid of reactance then the measured power cannot be considered to be RMS power. It therefore becomes apparent that this parameter would be difficult to measure with any degree of accuracy at RF frequencies.

**spurious emissions:** emissions on a frequency or frequencies which are outside the necessary bandwidth and the level of which may be reduced without affecting the corresponding transmission of information. Spurious emissions include harmonic emissions, parasitic emissions, intermodulation products and frequency conversion products but exclude out of band emissions.

**unwanted emissions:** consist of spurious emissions and out-of-band emissions

## 3.2 Symbols

For the purposes of the present document, the following symbols apply:

C/N	Carrier power to Noise power density
$\mu$	micro, $10^{-6}$

## 3.3 Abbreviations

For the purposes of the present document, the following abbreviations apply:

BER	Bit Error Ratio
COFDM	Coded Orthogonal Frequency Division Multiplex
CRC	Cyclic Redundancy Check
CW	Continuous Wave
EMC	ElectroMagnetic Compatibility
ETI	Ensemble Transport Interface
EUT	Equipment Under Test
FIB	Fast Information Blocks
FIC	Fast Information Channel
Hz	Hertz (cycles per second)
IEC	International Electrotechnical Commission
IF	Intermediate Frequency
ITU	International Telecommunications Union
LV	Low Voltage
N	Noise power
NI	Network Independent layer
PRBS	Pseudo Random Binary Sequence
R&TTE	Radio and Telecommunications Terminal Equipment
RF	Radio Frequency
rms	root mean square
SFN	Single Frequency Network
T-DAB	Terrestrial - Digital Audio Broadcast
Tx	Transmitter
V	Volt
VHF	Very High Frequency
W	Watt



---

## 4 Technical requirements specifications

### 4.1 Environmental profile

The environmental profile for operation of the equipment shall be declared by the supplier. The equipment shall comply with all the technical requirements of the present document at all times when operating within the boundary limits of the required operational environmental profile.

### 4.2 Transmitter output characteristics

#### 4.2.1 Rated output power

##### 4.2.1.1 Definition

The rated output power is the power that the transmitter shall deliver at its antenna port under the manufacturers specified conditions of operation.

NOTE: It is, however, recommended that this parameter is not quoted as RMS power.

##### 4.2.1.2 Method of measurement

###### 4.2.1.2.1 Initial conditions

Test environment:

The normal operating environment, as declared by the equipment manufacturer.

Test frequencies:

- a) the lowest operating frequency of the EUT;
- b) the highest operating frequency of the EUT;
- c) a frequency mid-way between a) and b) above.

Test arrangement: (see figure A.1)

- 1) all ports unused at the time of testing shall be correctly terminated;
- 2) connect the EUT to the Test Load, via the Coupling Device or via the attenuator;
- 3) connect the measuring device to the Coupling Device or attenuator.

###### 4.2.1.2.2 Procedure

The power of the signal of a T-DAB transmitter is defined as the long-term average of the time-varying short-term signal power. An appropriate instrument for T-DAB power measurements is a thermal power meter.

NOTE: The signal power is constant symbol by symbol. A certain short-term variation is especially given by the Null symbol.

#### 4.2.1.2.3 Test requirements

The results obtained shall be compared to the limits in clause 4.2.1.3 in order to demonstrate compliance.

#### 4.2.1.3 Limit

The output power shall be within  $\pm 0,5$  dB of the rated output power under normal operating conditions as defined by the manufacturer.

### 4.2.2 Frequency stability

#### 4.2.2.1 Definition

The frequency stability of an emission is the variation of frequency against a predetermined time scale.

#### 4.2.2.2 Method of measurement

##### 4.2.2.2.1 Initial conditions

Test environment:

The normal operating environment, as declared by the equipment manufacturer.

Test frequencies:

Any one frequency within the tuning range of the EUT.

Test arrangement: (see figure A.1)

- 1) all ports unused at the time of testing shall be correctly terminated;
- 2) connect the EUT to the Test Load, via the Coupling Device or via the attenuator;
- 3) connect the measuring device to the Coupling Device or attenuator.

NOTE: Alternatively the transmitter local oscillator may be measured in order to calculate the frequency stability of the EUT RF output signal.

##### 4.2.2.2.2 Procedure

The characteristic frequency may be measured with any suitable measuring device, provided that the accuracy attained during the measurement is better than approximately 10 % of the frequency tolerance or the frequency stability given in the relevant equipment specification of the transmitter.

For a tight frequency tolerance or a high degree of frequency stability, the measuring accuracy stated above puts higher demands on the accuracy of the measuring equipment.

In this case, the measurements shall preferably be made with a recording instrument.

The accuracy of the measuring method, if known, shall be stated with the results of the measurements. If not known, an estimate should be given.

The conditions of operation shall also be given together with the assigned frequency of the emission, which has been used as the characteristic frequency.

##### 4.2.2.2.3 Test requirements

The results obtained shall be compared to the limits in clause 4.2.2.3 in order to demonstrate compliance.

### 4.2.2.3 Limit

The centre frequency of the RF signal shall not deviate more than 10 % of the relevant carrier spacing from its nominal value. This results in the following allowance for frequency deviation:

- transmission mode I < 100 Hz;
- transmission mode IV < 200 Hz;
- transmission mode II < 400 Hz;
- transmission mode III < 800 Hz.

The stability of the centre frequency shall be better than:

- transmission mode I  $\pm 10$  Hz;
- transmission mode IV  $\pm 20$  Hz;
- transmission mode II  $\pm 40$  Hz;
- transmission mode III  $\pm 80$  Hz;

within a three month period when measured under identical operating conditions at the start and at the end of the period.

## 4.2.3 Crest factor

### 4.2.3.1 Definition

Maximum ratio of peak power to mean power levels.

### 4.2.3.2 Method of measurement

#### 4.2.3.2.1 Initial conditions

Test environment:

The normal operating environment, as declared by the equipment manufacturer.

Test frequencies:

- a) the lowest operating frequency of the EUT;
- b) the highest operating frequency of the EUT;
- c) a frequency mid-way between a) and b) above.

Test arrangement: (see figure A.1)

- 1) all ports unused at the time of testing shall be correctly terminated;
- 2) connect the EUT to the Test Load, via the Coupling Device or attenuator;
- 3) connect the measuring device to the Coupling Device or attenuator.

#### 4.2.3.2.2 Procedure

Using a suitable measuring device first record the peak power then record the mean power.

#### 4.2.3.2.3 Test requirements

The results obtained shall be compared to the limits in clause 4.2.3.3 in order to demonstrate compliance.

#### 4.2.3.3 Limit

The peak level of the output RF power signal shall not exceed the mean power level by more than 13 dB.

### 4.3 Digital signal processing

#### 4.3.1 Signal delay of T-DAB transmitters

##### 4.3.1.1 Definition

The overall signal delay of the T-DAB transmitter is the time difference from the start of the first bit of the ETI(NI) frame with frame phase 0 to the start of the Null symbol of the corresponding transmission frame at the RF output. (See ETS 300 799 [3], clause C.6).

##### 4.3.1.2 Method of measurement

###### 4.3.1.2.1 Initial conditions

Test environment:

The normal operating environment, as declared by the equipment manufacturer.

Test arrangement: (see figure C.2).

###### 4.3.1.2.2 Procedure

A possible means of determining the delay of a transmitter is to insert a specific test pattern into the ETI signal and observe the COFDM signal at IF or RF. Annex C provides details of a possible implementation of this method.

###### 4.3.1.2.3 Test requirements

The results obtained shall be compared to the limits in clause 4.3.1.3 in order to demonstrate compliance.

##### 4.3.1.3 Limit

Transmitters that are operated in SFNs (Single Frequency Networks) shall provide additional adjustable delay. This adjustable delay shall allow the overall delay to be increased to at least 500 ms in all modes, with a maximum step of 1  $\mu$ s.

Manual setting of the adjustable delay is the minimum requirement. Provision should be made for automatic dynamic delay compensation.

NOTE: Adjustable delay may also be a requirement in particular situations when analogue and digital transmissions have to be synchronized.

#### 4.3.2 Behaviour in case of erroneous ETI signal

##### 4.3.2.1 Definition

Operational status of transmitter during ETI signal error.

##### 4.3.2.2 Method of measurement

###### 4.3.2.2.1 Initial conditions

Test environment:

The normal operating environment, as declared by the equipment manufacturer.

Test arrangement: (see clause B.1).

#### 4.3.2.2.2 Procedure

See annex B.

#### 4.3.2.2.3 Test requirements

The results obtained shall be compared to the limits in clause 4.3.2.3 in order to demonstrate compliance.

#### 4.3.2.3 Limit

The Minimum Requirements for Terrestrial DAB Transmitters shall be:

- $P = 4$ ;
- $Q = 40$ ;
- $M = 80$ .

If the input signal is absent, or if frame synchronization is not achieved, the transmitter RF signal shall be muted in line with spurious emission limits, clause 4.4.1.2.4.

If frame synchronization is achieved, but CRC violations are detected, the transmitter shall offer two alternative responses:

- a) The output RF signal is not affected by sporadic single CRC violations. The output RF signal is switched off after  $P$  CRC violations in  $Q$  frames, and switched on after  $M$  consecutive frames free from CRC violations.
- b) The output RF signal is transmitted irrespective of CRC violations.

After the warming-up time of the transmitter the output RF signal shall be stable within two seconds following the application of an error-free input signal.

### 4.3.3 BER-Performance degradation

#### 4.3.3.1 Definition

Difference between theoretical and actual BER degradation.

#### 4.3.3.2 Method of measurement

##### 4.3.3.2.1 Initial conditions

Test environment:

The normal operating environment, as declared by the equipment manufacturer.

Test arrangement: (see clause B.2).

##### 4.3.3.2.2 Procedure

For this measurement a test receiver should be used. In principle only the degradation of the whole chain (transmitter and receiver) can be assessed, but this can provide a useful indication of transmitter degradation.

The receiver is connected to the output of the transmitter (without insertion of a channel simulator). Error correction shall be enabled in both the EUT and the receiver. Band limited noise is added to the T-DAB signal at the receiver input in order to achieve a given value of BER. Adjustable attenuators are used to set both the input power ( $C$ ) and the noise power ( $N$ ) to appropriate values at the input of the receiver. BER is the ratio of erroneous bits of the received data to the total bits of the received data during the measurement interval. The power of the added noise,  $N$ , is measured within the nominal T-DAB bandwidth of 1,536 MHz.

#### 4.3.3.2.3 Test requirements

The results obtained shall be compared to the limits in clause 4.3.3.3 in order to demonstrate compliance.

#### 4.3.3.3 Limit

An operational transmitter shall not degrade the theoretical system BER (with channel coding and decoding) by more than 1 dB, under the conditions set out in tables 4.1 and 4.2.

**Table 4.1: BER Performance degradation limits**

Code Rate R for equal convolutional coding	0,5
Transmission modes	all T-DAB modes
Theoretical performance	according to table 4.2

**Table 4.2: BER Performance degradation limits**

BER	C/N
$1 \times 10^{-2}$	5,0 dB
$3 \times 10^{-3}$	5,4 dB
$1 \times 10^{-3}$	5,8 dB
$3 \times 10^{-4}$	6,2 dB
$1 \times 10^{-4}$	6,6 dB
$3 \times 10^{-5}$	6,9 dB
$1 \times 10^{-5}$	7,2 dB
$3 \times 10^{-6}$	7,5 dB
$1 \times 10^{-6}$	7,8 dB

Theoretical BER performance in Gaussian channel (equal error protection with  $R = 0,5$ ).

## 4.4 Antenna port measurements

### 4.4.1 Spurious emissions

#### 4.4.1.1 Definition

Emission on a frequency or frequencies which are outside the necessary bandwidth and the level of which may be reduced without affecting the corresponding transmission of information. Spurious emissions include harmonic emissions, parasitic emissions, intermodulation products and frequency conversion products but exclude out of band emissions.

For the purposes of the present document spurious emissions are emissions at frequencies outside the frequency range  $f_0 \pm 3$  MHz, where  $f_0$  is the centre frequency of the transmission, irrespective of the number of carriers employed.

#### 4.4.1.2 Method of measurement (essential test suite)

##### 4.4.1.2.1 Initial conditions

Test environment:

The normal operating environment, as declared by the equipment manufacturer.

Test frequencies:

- a) the lowest operating frequency of the EUT;
- b) the highest operating frequency of the EUT;

- c) a frequency mid-way between a) and b) above.

Test arrangement: (see figure A.1)

- 1) all ports unused at the time of testing shall be correctly terminated;
- 2) connect the EUT to the Test Load, via the Coupling Device or via the attenuator;
- 3) connect the measuring device to the Coupling Device or attenuator.

#### 4.4.1.2.2 Procedure

- 1) operate the EUT at each of the test frequencies as defined in clause 4.4.1.2.1;
- 2) measure the results on the Spectrum Analyser.

#### 4.4.1.2.3 Test requirements

The results obtained shall be compared to the limits in clause 4.4.1.3 in order to demonstrate compliance.

#### 4.4.1.3 Limit

Spurious emissions shall not exceed the values set out in table 4.3, shown additionally in figures 4.1 and 4.2, for the frequency range 9 kHz to 1 GHz or 3<sup>rd</sup> Harmonic whichever is higher.

NOTE: In the case of a T-DAB transmitter supplied without an internal bandpass output filter, the manufacturer shall specify the characteristics of the filter necessary to fulfil the spurious emission limits defined in table 4.3. The manufacturer shall include this information in their test report.

**Table 4.3: Spurious emissions limits**

Frequency range of the spurious emission (MHz)	Limits of the spurious emission	Reference bandwidth (kHz)	Figure
9 kHz - 174	-36 dBm (250 nW)	100	4.1
> 174 - 400	-82 dBm, for $P \leq 25$ W -126 dBc, for $25$ W < $P \leq 1\ 000$ W -66 dBm, for $1\ 000$ W < $P$	4	4.2
> 400 - 1 000	-36 dBm (250 nW)	100	4.1
> 1 000 - 1 452	-30 dBm (1 $\mu$ W)	100	4.1
> 1 452 - 1 492	-62 dBm, for $P \leq 25$ W -106 dBc, for $25$ W < $P \leq 1\ 000$ W -46 dBm, for $1\ 000$ W < $P$	4	4.2
> 1 492	-30 dBm (1 $\mu$ W)	100	4.1

NOTE: P = mean power of the transmitter.

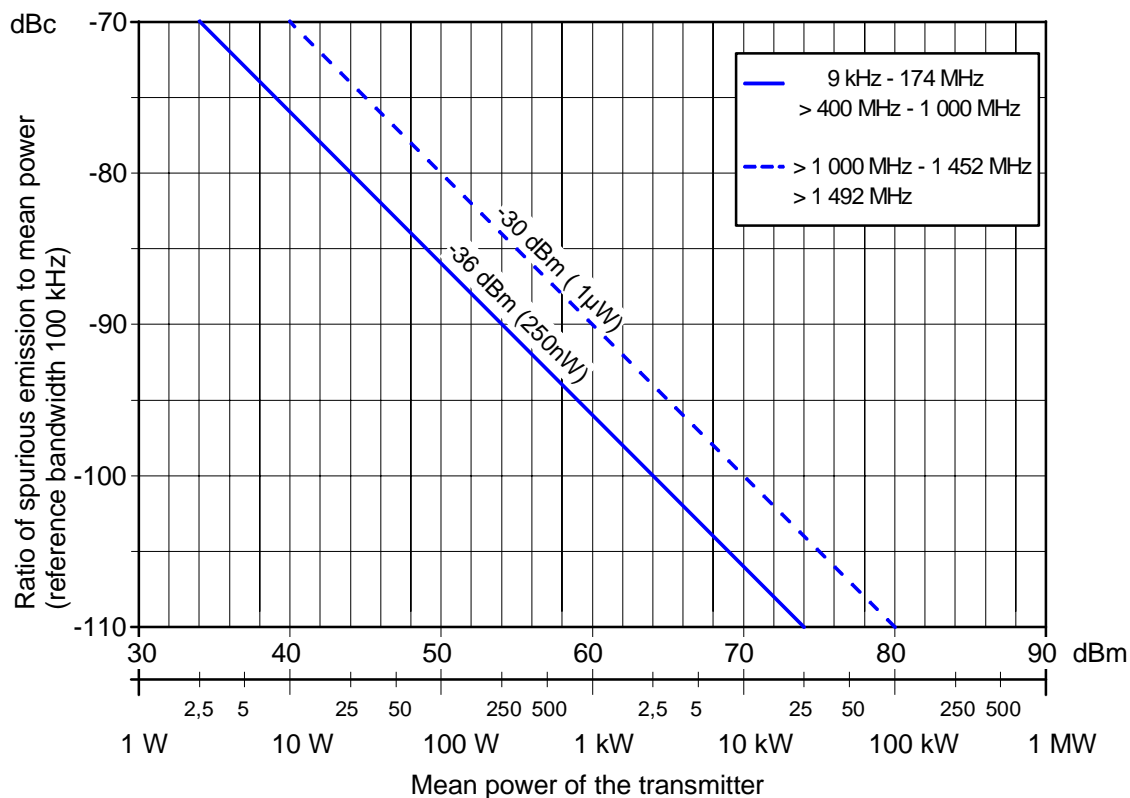

Figure 4.1: Spurious emissions limits for T-DAB transmitters (100 kHz reference bandwidth)

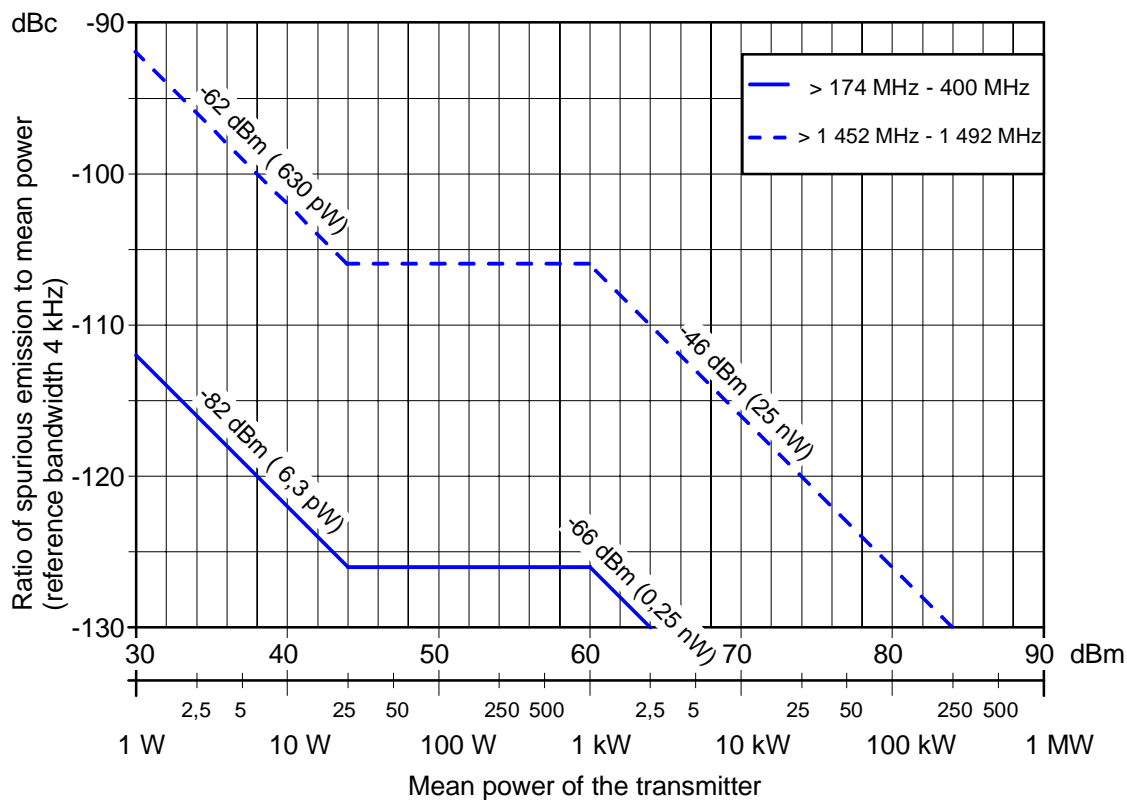

Figure 4.2: Spurious emissions limits for T-DAB transmitters (4 kHz reference bandwidth)



## 4.4.2 Out-of-band emissions

### 4.4.2.1 Definition

Emission on a frequency or frequencies immediately outside the necessary bandwidth which results from the modulation process, but excludes spurious emissions.

For the purposes of the present document out-of-band emissions are emissions at frequencies outside the necessary bandwidth and within the frequency range  $f_0 \pm 3$  MHz, where  $f_0$  is the centre frequency of the transmission, irrespective of the number of carriers employed.

### 4.4.2.2 Method of measurement (essential test suite)

#### 4.4.2.2.1 Initial conditions

Test environment:

The normal operating environment, as declared by the equipment manufacturer.

Test frequencies:

- a) the lowest operating frequency of the EUT;
- b) the highest operating frequency of the EUT;
- c) a frequency mid-way between a) and b) above.

Test arrangement: (see figure A.2).

#### 4.4.2.2.2 Procedure

- 1) all ports unused at the time of testing shall be correctly terminated;
- 2) operate the EUT at each of the test frequencies as defined in clause 4.4.2.2.1 and in each relevant T-DAB operating mode;
- 3) measure the results on the Spectrum Analyser.

#### 4.4.2.2.3 Test requirements

The results obtained shall be compared to the limits in clause 4.4.2.3 in order to demonstrate compliance.

### 4.4.2.3 Limit

Out-of-band emissions shall not exceed the limits specified in tables 4.4 and 4.5, additionally shown in figures 4.3 and 4.4.

Out-of-band emissions limits are given as mean power level measured in a 4 kHz bandwidth, where 0 dB corresponds to the mean output power.

Unless otherwise declared by the manufacturer it shall be assumed that the EUT conforms to the non-critical case (case2).

- Case 1: The solid line mask shall apply to VHF T-DAB transmitters operating in areas critical for adjacent channel T-DAB to T-DAB interference, and in any case when it is necessary to protect other services operating on adjacent frequencies on a primary basis.
- Case 2: The dashed line mask shall apply to VHF T-DAB transmitters in other cases and to 1,5 GHz T-DAB transmitters.
- Case 3: The solid line mask shall apply to VHF T-DAB transmitters in exceptional circumstances to protect safety services.

Case 4: The chain dotted line mask shall apply to VHF T-DAB transmitters operating in channel 12D and on a case by case basis in certain areas.

NOTE: In the case of a DVB-T transmitter supplied without an internal bandpass output filter, the manufacturer shall specify the characteristics of the filter necessary to fulfil the out-of-band emission masks defined in tables 4.4 and 4.5. The manufacturer shall include this information in their test report.

**Table 4.4: Transmitters operating with output power between 25 W and 1 000 W**

Classification accordingly the frequency assignment	1,54 MHz block, frequency difference from the centre frequency (MHz)	Relative level
		(dBc)
VHF T-DAB transmitters operating in uncritical cases or in the L-band (case 2)	±0,97	-26
	±0,97	-56
	±3,0	-106
VHF T-DAB transmitters operating in critical cases (case 1)	±0,77	-26
	±0,97	-71
	±1,75	-106
VHF T-DAB transmitters operating in exceptional circumstances to protect safety services (case 3)	±3,0	-106
	±0,77	-26
	±0,97	-71
VHF T-DAB transmitters operating in the channel 12D and certain areas (case 4)	±2,2	-126
	±3,0	-126
	±0,77	-26
	±0,97	-78
	±2,2	-126
	±3,0	-126

**Table 4.5: Transmitters operating with output power < 25W and > 1 000 W**

Classification accordingly the frequency assignment	1,54 MHz block, frequency difference from the centre frequency (MHz)	Absolute level (dBm)	
		for transmitter with output power	
		< 25 W	> 1 000 W
VHF T-DAB transmitters operating in uncritical cases or in the L- band (case 2)	±0,97	18	34
	±0,97	-12	4
	±3,0	-62	-46
VHF T-DAB transmitters operating in critical cases (case 1)	±0,77	18	34
	±0,97	-27	-11
	±1,75	-62	-46
VHF T-DAB transmitters operating in exceptional circumstances to protect safety services (case 3)	±3,0	-62	-46
	±0,77	18	-34
	±0,97	-27	-11
VHF T-DAB transmitters operating in the channel 12D and certain areas (case 4)	±2,2	-82	-66
	±3,0	-82	-66
	±0,77	18	-34
	±0,97	-34	-18
	±2,2	-82	-66
	±3,0	-82	-66

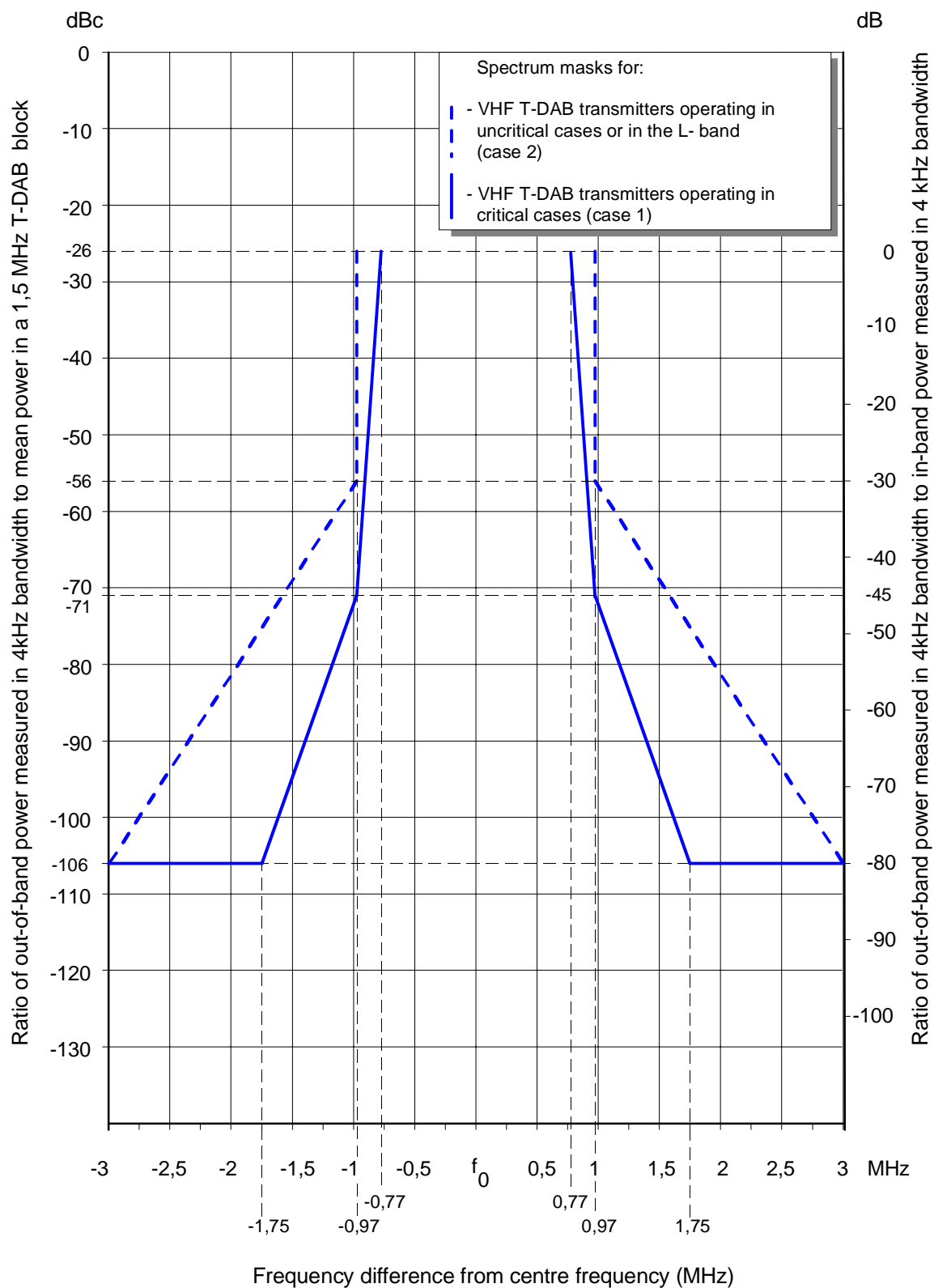

Figure 4.3: Spectrum masks for T-DAB out-of-band emissions (case 1 and case 2)

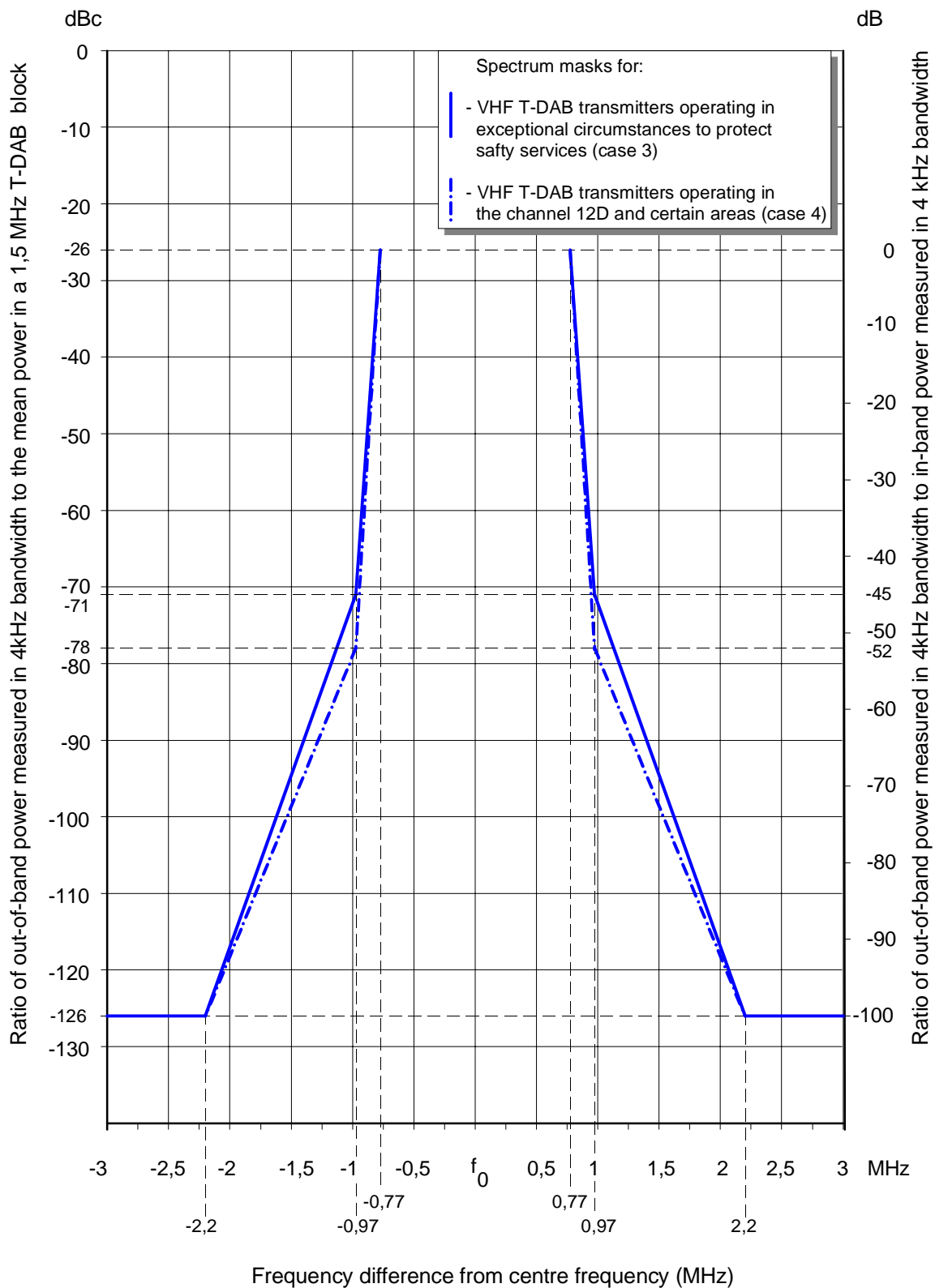

Figure 4.4: Spectrum masks for T-DAB out-of-band emissions (case 3 and case 4)

## 4.5 Enclosure port measurements (radiated emissions)

### 4.5.1 Cabinet radiation

#### 4.5.1.1 Definition

Emissions from the equipment, radiated from the enclosure port, other than those present at the antenna port.

#### 4.5.1.2 Method of measurement (essential test suite)

##### 4.5.1.2.1 Initial conditions

Test environment:

The normal operating environment, as declared by the equipment manufacturer.

Test frequencies:

- a) the lowest operating frequency of the EUT;
- b) the highest operating frequency of the EUT;
- c) a frequency mid-way between a) and b) above.

Test arrangement: (see figure A.3).

For the purposes of this test no test signal is required, the manufacturer shall ensure that the full rated output power of the transmitter will be maintained during this test.

##### 4.5.1.2.2 Procedure

The test method shall be in accordance with EN 55022 [4], unless physical size is a restriction, in which case the test method shall be in accordance with EN 55011 [5].

- measurements shall be made outside the exclusion band (see table 4.6);
- measurements shall be made in the operational mode producing the largest emission in the frequency band being investigated consistent with normal applications;
- the equipment shall be configured in a manner which is representative of a normal/typical operation, where practical;
- an attempt shall be made to maximize the detected radiated emission, e.g. by moving the cables of the equipment;
- the configuration and mode of operation during measurements shall be precisely noted in the test report;
- RF input/output ports shall be correctly terminated;
- the tests shall be carried out at a point within the specified normal operating environmental range and at the rated supply voltage for the equipment.

##### 4.5.1.2.3 Test requirements

The results obtained shall be compared to the limits in clause 4.5.1.3 in order to demonstrate compliance.

### 4.5.1.3 Limit

Radiated emissions shall not exceed the values set out in table 4.6, shown additionally in figure 4.5, for the frequency range 30 MHz to the upper limit.

This test shall be performed at a distance of 10 m, where feasible. When size and/or power requirements necessitate testing in a manufacturing facility, other distances may be used (see notes 1 to 3). Tests shall not be carried out in the exclusion band (see note 2 in table 4.6).

**Table 4.6: Cabinet radiation limits**

Quasi-peak limits (dB $\mu$ V/m) at 10 m (see notes 1 and 2)	Frequency range
$30 \text{ dB}\mu\text{V/m} \leq 60 + 10 \log_{10} (P_0/2\,000) \leq 70 \text{ dB}\mu\text{V/m}$	30 MHz to 230 MHz
$37 \text{ dB}\mu\text{V/m} \leq 67 + 10 \log_{10} (P_0/2\,000) \leq 77 \text{ dB}\mu\text{V/m}$	> 230 MHz to Upper limit
NOTE 1: $P_0$ = RF output power in W.	
NOTE 2: The exclusion band for the transmitter extends from $F_c - 3$ MHz to $F_c + 3$ MHz, where $F_c$ is the operating frequency in MHz.	
NOTE 3: Upper frequency limit = 1 GHz or 3 <sup>rd</sup> Harmonic, whichever is higher.	

NOTE 1: The measurements can be carried out at other distances. In that case limits are modified according to the relation:

$$L(x) = L(10\text{m}) + 20 \log (10/x) \quad \text{where } x = \text{distance in meter (m)}.$$

NOTE 2: Care should be taken if measuring at test distances below 10 m as this may be in the near field.

NOTE 3: In cases of dispute the measurement distance of 10 m shall take precedence.

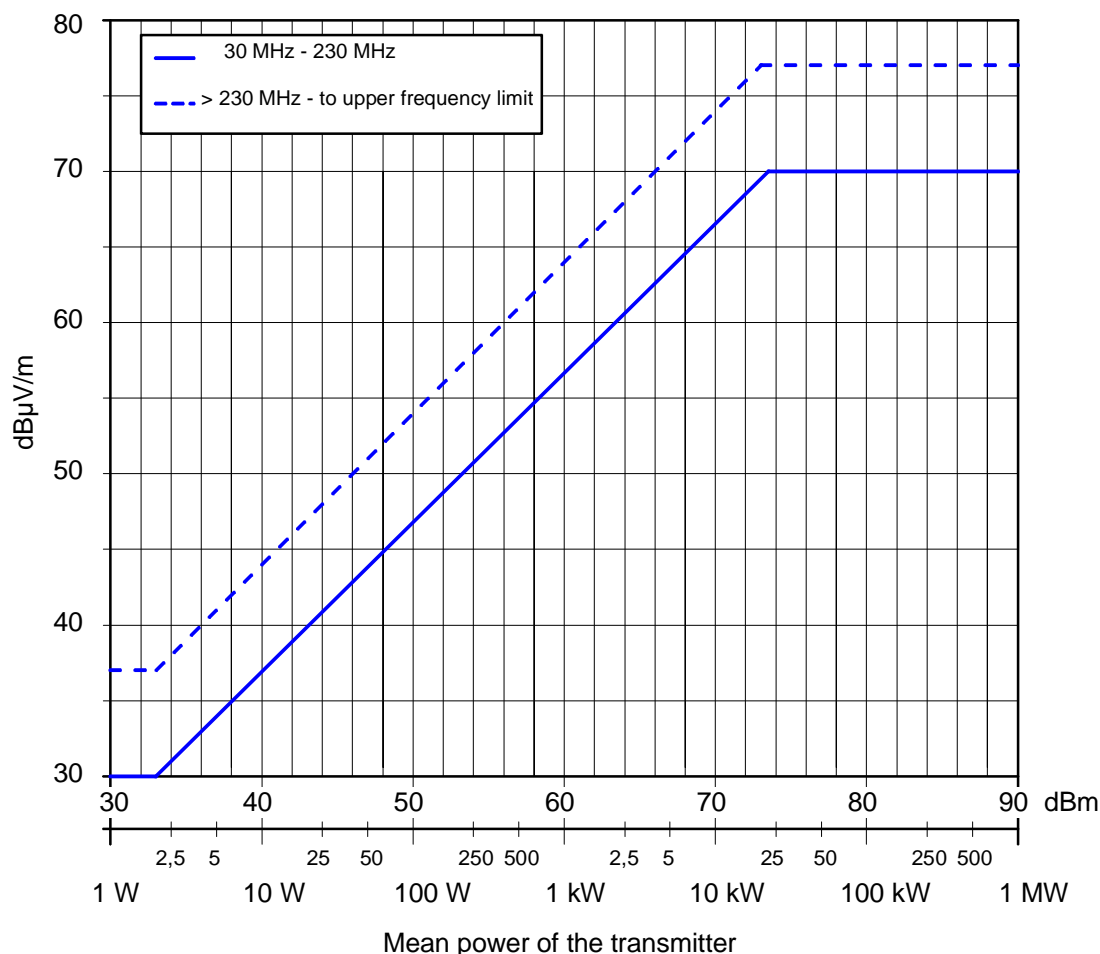

**Figure 4.5: Cabinet radiation limits for T-DAB transmitters**

## 4.6 Measurement uncertainties

Measurement uncertainty should be calculated and techniques employed to minimize its range. This uncertainty should be applied to the limit and any measurement falling below the range is deemed acceptable [7].

## Annex A (normative): General measuring arrangements

### A.1 Testing arrangements for antenna port measurements

#### A.1.1 Spurious emissions

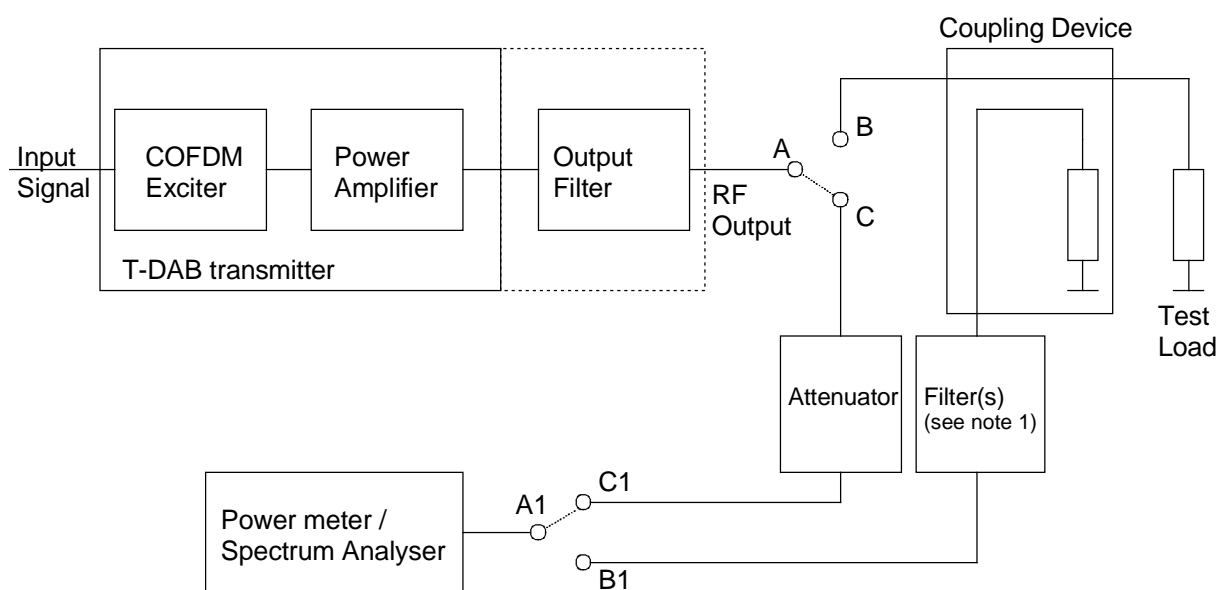

NOTE 1: The optional filter should suppress the output signal so that no intermodulation products are generated by the spectrum analyser. The insertion loss throughout the measuring range should be known.

NOTE 2: For high power transmitters the preferred set up would require A to be connected to B and A1 to be connected to B1.

NOTE 3: For low power transmitters the preferred set up would require A to be connected to C and A1 to be connected to C1.

NOTE 4: If the transmitter does not include any output filter, an external filter shall be added after the transmitter for the testing arrangement. This filter shall be representative of the multiplexer or filter existing in operational conditions and viewed by the transmitted output when installed. In this case, the antenna port measurements shall be performed at the output of this extra filter.

**Figure A.1: Testing arrangement for spurious emissions**



## A.1.2 Out-of-band emissions

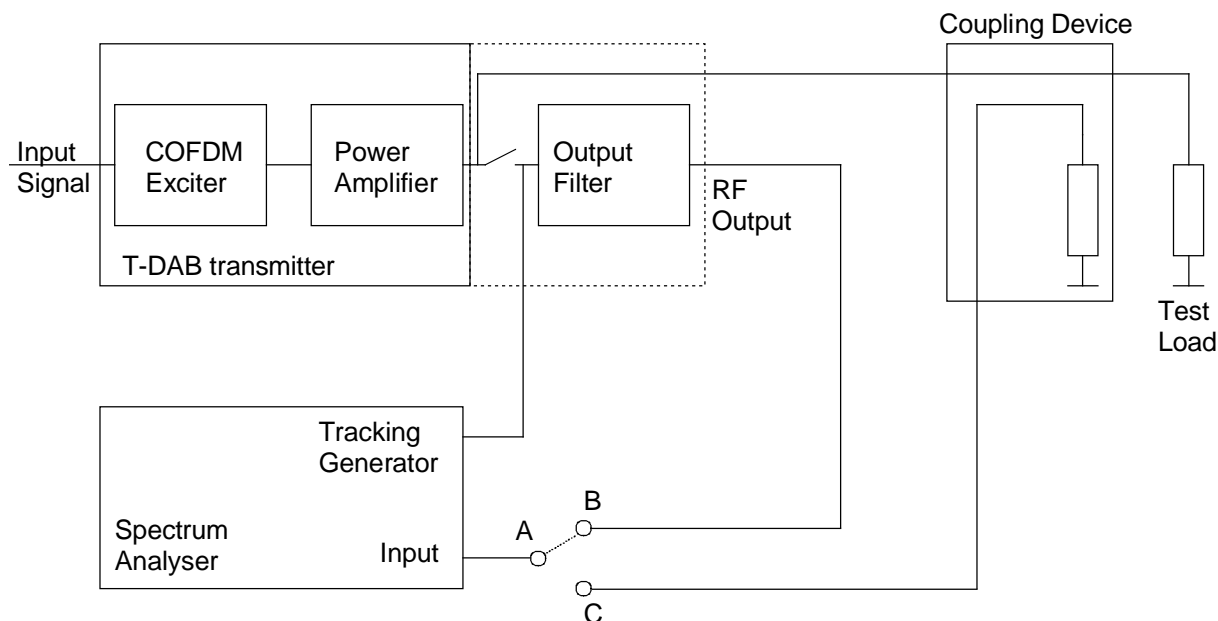

NOTE 1: Disconnect the power amplifier from the output filter.

NOTE 2: The frequency response of the output filter must be measured and recorded (connection A-B).

NOTE 3: The spectrum of the T-DAB signal at the output of the power amplifier must be measured and recorded (connection A-C).

NOTE 4: The out-of-band spectrum of the T-DAB signal shall be calculated by applying the recorded frequency response of the output filter to the recorded spectrum of the T-DAB signal.

NOTE 5: If the transmitter does not include any output filter, an external filter shall be added after the transmitter for the testing arrangement. This filter shall be representative of the multiplexer or filter existing in operational conditions and viewed by the transmitted output when installed. In this case, the antenna port measurements shall be performed at the output of this extra filter.

**Figure A.2: Testing arrangement for out-of-band emissions**

## A.1.3 Test frequency range

Limits on unwanted emissions for radio equipment are considered to be applicable to the range 9 kHz to 300 GHz. However, for practical measurement purposes, the frequency range of spurious emissions may be restricted. As guidance for practical purposes, the following measurement parameters in table A.1 are recommended:

**Table A.1: Test frequency range**

Transmitter fundamental frequency range	Unwanted emission frequency measurement range	
	lower frequency	upper frequency
47,936 MHz to 1 492 MHz	9 kHz	1 GHz or 3 <sup>rd</sup> Harmonic whichever is higher

The following reference bandwidths are to be used:

For Spurious Emissions:

- 100 kHz between 9 kHz and 174 MHz;
- 4 kHz between 174 MHz and 400 MHz;
- 100 kHz between 400 MHz and 1 452 MHz;

- 4 kHz between 1 452 MHz and 1 492 MHz;
- 100 kHz above 1 492 MHz.

For Out-of- band Emissions:

- 4 kHz.

### A.1.4 Test modulating signal

No special test signal is required, however an input signal should be provided, according to the specification of the transmitter, to obtain a valid T-DAB output signal.

## A.2 Testing arrangements for enclosure port (radiated emissions) measurements

Further guidance can be found in IEC 60489-1 amendment 2 [6].

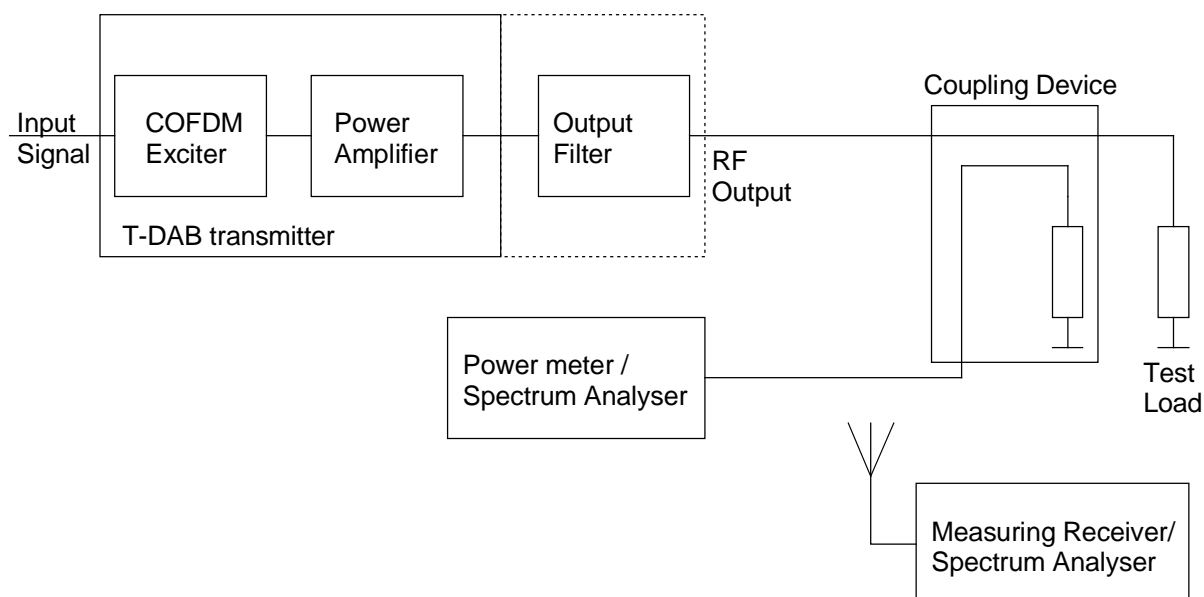

NOTE: If the transmitter does not include any output filter, an external filter shall be added after the transmitter for the testing arrangement. This filter shall be representative of the multiplexer or filter existing in operational conditions and viewed by the transmitted output when installed.

**Figure A.3: Testing arrangement for cabinet radiation**

---

## Annex B (informative): Typical COFDM measuring arrangements

### B.1 ETI errors



Figure B.1: ETI Test arrangement

---

### B.2 Bit Error performance measurement

#### B.2.1 Test procedure

- Run the EUT for at least 30 min at its nominal power.
- Set the spectrum analyser centre frequency to the Tx frequency, Span to 5 MHz, Reference Band Width to 30 kHz, Video Band Width to 100 Hz.- Make sure that the internal noise of the analyser is less than 25 dB below the noise source output. Make sure that the analyser is not overloaded.
- Adjust the variable attenuator and/or the noise source output until the spectrum Analyser shows the desired  $(C + N_o)/N_o$ . Use the Marker to read the results from the analyser.

EXAMPLE: For 5 dB  $C/N_o$ , the T-DAB signal on the analyser display is 6,2 dB above the noise level.

- Set the EUT and the T-DAB Receiver according to the instructions below.
- The Bit Error ratio is displayed on the BER analyser.

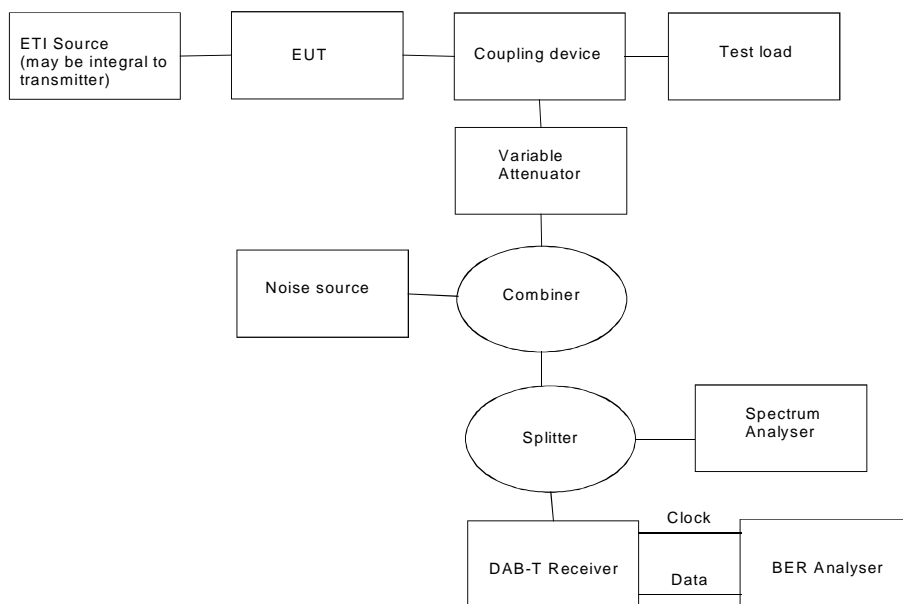
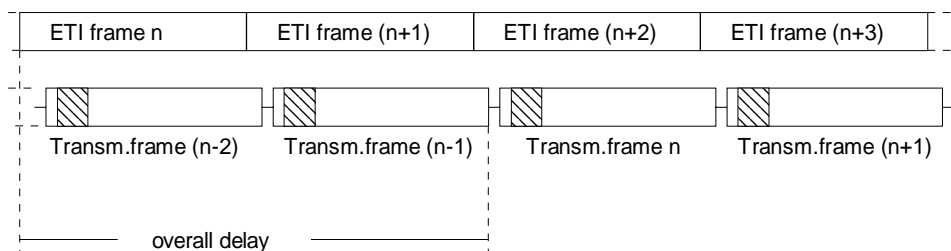

**Figure B.2: Bit error performance measurement**

## Annex C (informative): Measurement of the overall delay of a T-DAB transmitter

In an SFN the transmitters have to transmit the symbols synchronous in time and frequency. To set up an SFN the overall delay time of each transmitter including delay compensation has to be known.

According to clause 4.3.3.1 the overall delay of a T-DAB transmitter is defined as the time difference from the start of the first bit of the ETI(NI) frame with phase 0 to the start of the Null symbol of the corresponding transmission frame at the RF output. It comprises the processing delay and the additional adjustable delay.



**Figure C.1: Overall transmitter delay**

Figure C.1 illustrated for the case of transmission mode II and III.

The problem is to identify the output frame corresponding to a specific ETI frame.

### Detection of a transmission frame in the analogue output signal

It is not possible to observe a specific subchannel because the subchannels are time interleaved. So the solution is to fill the FIC with a specific data pattern and to detect this specific FIC at the analogue output of the COFDM encoder or the whole transmitter.

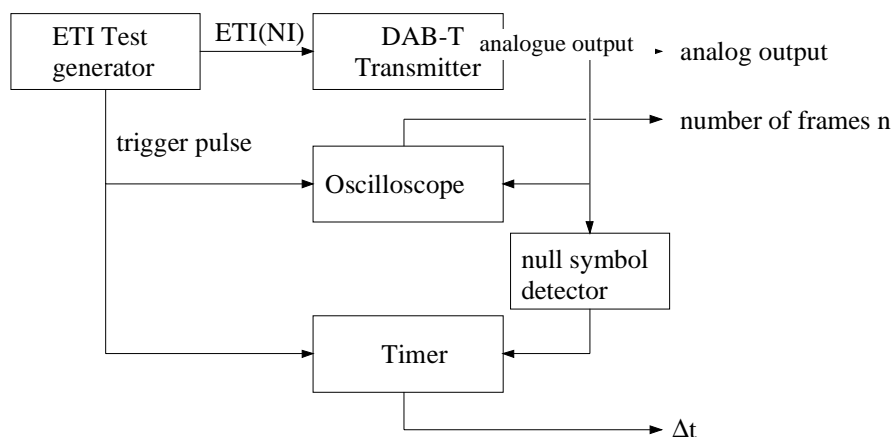

**Figure C.2: Measurement of the overall transmitter delay**

The ETI test generator periodically inserts Fast Information Blocks (FIB) with a specific data pattern into ETI frames with frame phase 0. A suitable period is e. g. 32 frames. It also generates a trigger pulse synchronous to the start of this ETI frame which is used to trigger a storage oscilloscope.

In a COFDM encoder the first FIC symbol is calculated by differential encoding the frequency interleaved data with reference to the phase states of the phase reference symbol. For example if the frequency interleaved data of the following symbol would be all zero the envelope of the phase reference symbol would be repeated.

The specific FIBs result in specific FIC symbols. Their waveform can be detected with an oscilloscope suitable for the frequency range of the T-DAB Signal, e. g. an IF signal. So the user has to count the number of complete transmission frames until the specific FIC appears.

Finally the time difference between the start of the ETI frame and the first displayed transmission frame after the trigger pulse has to be measured. This can be done by detecting the null symbol and generate a synchronous pulse. Then the difference between this pulse and the trigger pulse can be measured with a timer.

### Calculating the overall delay

The overall delay is given by the following expression:

$$\text{delay} = n \times T_f + \Delta t$$

with:  $n$  number of complete transmission frames.

$T_f$  duration of a transmission frame.

$\Delta t$  difference between trigger pulse and null symbol pulse.

Figures C.3 and C.4 show the difference of a normal FIC waveform and a FIC waveform with a specific data pattern as can be observed at an oscilloscope screen.

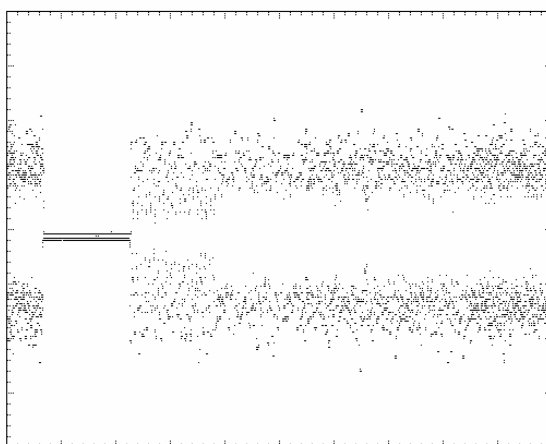

Figure C.3: FIC with normal data

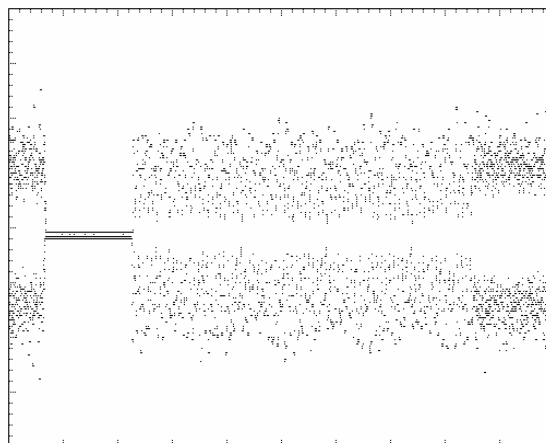

Figure C.4: FIC with specific data pattern

---

## Annex D (informative): Delay type and delay management

There are a number of types of delay adjustment that may be defined for operational purposes. These are:

### **Transmitter Trimming Delay**

Used to ensure that transmitters from different manufacturers have the same nominal delay. By implication, the adjustment range provided for this compensation, added to the delay to the basic transmitter, must meet the maximum delay specification in clause 4.3.1.3.

### **Transmitter Offset Delay**

Used to adjust the relative timings of transmitters within an SFN, in order to optimize reception. The range needed for this adjustment is in the order of 0  $\mu$ s to 2 000  $\mu$ s.

### **Network Padding Delay**

Used to compensate the delays in the distribution systems, to ensure that the network is synchronized. Some introductory networks may require up to several hundred milliseconds of adjustment. Network adaptation would normally be expected to include compensation for delays in the distribution system, removing the need for Network Padding Delay in the basic transmitter.

---

## Annex E (informative): Spectrum measurements

The spectrum mask is defined in relation to spectrum density measured in 4 kHz bandwidth.

The spectral density of a T-DAB signal shall be defined as the long-term average of the time-varying signal power per unity bandwidth (i.e. 1 Hz). Values for other bandwidths can be achieved by proportional increase of the values for unity bandwidth.

The spectral density of a T-DAB signal can in principle be determined by the following procedure: The T-DAB signal is applied to a band filter with rectangular passband characteristics and a known bandwidth (typically 10 kHz) and with an adjustable centre frequency. The output of the filter is measured by a power meter that delivers real mean values and integrates as long as necessary (typically 2 transmission frames) to get constant readings. These readings can be interpreted as the average spectral density for the measurement bandwidth used. By moving the centre frequency step by step across the T-DAB signal and adjacent frequency regions the frequency dependent average of the spectral density can be found. The derivation of the average spectrum density for the unity bandwidth is straightforward. In practice such measurements will often be performed by using a spectrum analyser. It has to be analysed to what extent the device follows the principles given above. In particular, equivalent noise bandwidth and RMS measurement need to be carefully checked.

Due to the prolongation of the COFDM symbol by the guard interval the spectral density inside the nominal bandwidth varies by about 3 dB with a periodicity of the carrier distance. This variation can only be observed in its entirety if the bandwidth of the spectral density measurement filter is low compared to the carrier distance. (The carrier distance is mode-dependent.)

**NOTE:** Low measurement bandwidth allows to detect small CW components within the COFDM spectrum. Those components that fall outside the nominal T-DAB frequency block should be treated separately from the COFDM signal as their impairment effect may be different.

To avoid regular structures in the modulated signal a non-regular, e.g. a PRBS like or a programme type digital transmitter-input signal, is necessary.

Care has to be taken that the input stage of the selective measurement equipment is not overloaded by the main lobe of the signal while assessing the spectral density of the side lobes, i.e. the out-of-band range. Especially in cases with very strong attenuation of the side lobes non-linear distortion in the measurement equipment can produce side lobe signals that mask the original ones. Selective attenuation of the main lobe has proven to be in principal a way to avoid this masking effect. However, as the frequency response of the band-stop filter has to be included in the evaluation the whole measurement procedure may become somewhat complex.



---

## Annex F (informative): Bibliography

ETSI EN 300 401: "Radio Broadcasting Systems; Digital Audio Broadcasting (DAB) to mobile, portable and fixed receivers".

ITU-T Recommendation G.703: "Physical/electrical characteristics of hierarchical digital interfaces".

EBU/EUREKA Project 147: "Digital Audio Broadcasting: Definition of the Digital Baseband I/Q Interface".

EBU/EUREKA Project 147: "The EUREKA DAB System: Guidelines for implementation and operation"  
December 1994.

Directive 1999/5/EC of the European Parliament and of the Council of 9 March 1999 on radio equipment and telecommunications terminal equipment and the mutual recognition of their conformity (R&TTE Directive).

Council Directive 89/336/EEC of 3 May 1989 on the approximation of the laws of the Member States relating to electromagnetic compatibility (EMC Directive).

Council Directive 73/23/EEC of 19 February 1973 on the harmonization of the laws of the Member States relating to electrical equipment designed for use within certain voltage limits (LV Directive).

CEPT/ERC/REC 74-01: "Spurious emissions".

ITU-R Recommendation SM 329-9: "Spurious emissions".

ITU-R Recommendation SM.328-10: "Spectra and bandwidth of emissions".

ITU-R Recommendation SM 1541: "Unwanted emissions in the Out-of-band domain".

ETSI ETR 290: "Digital Video Broadcasting (DVB); Measurement guidelines for DVB systems".

IEC 60244-1: "Methods of measurement for radio transmitters - Part 1: General characteristics for broadcast transmitters".

IEC 60244-6: "Methods of measurement for radio transmitters. Part 6: Cabinet radiation at frequencies between 130 kHz and 1 GHz".

IEC 61000-4-3/Am1 (2002): "Electromagnetic compatibility (EMC) Part 4-3: Testing and measurement techniques - Radiated, radio frequency, electromagnetic field immunity test".

The CEPT T-DAB planning meeting, Wiesbaden, 3rd to 21st July 1995; FINAL ACTS of the CEPT T-DAB Planning Meeting.

FINAL ACTS of the CEPT T-DAB Planning Meeting (4) Maastricht, 2002: "Special Arrangement of the European Conference of Postal and Telecommunications Administrations (CEPT) relating to the use of the band 1 452 MHz - 1 479,5 MHz for Terrestrial Digital Audio Broadcasting (T-DAB)".

---

## History

<b>Document history</b>		
V1.1.1	April 2004	Public Enquiry PE 20040827: 2004-04-28 to 2004-08-27
V1.1.1	November 2004	Vote V 20050121: 2004-11-22 to 2005-01-21