



**Transmitting equipment for the
Digital Audio Broadcasting (DAB) service;
Harmonised Standard for access to radio spectrum**

ReferenceREN/ERM-TG17-201

Keywordsaudio, broadcasting, DAB, digital, harmonised
standard, radio, regulation**ETSI**650 Route des Lucioles
F-06921 Sophia Antipolis Cedex - FRANCE

Tel.: +33 4 92 94 42 00 Fax: +33 4 93 65 47 16

Siret N° 348 623 562 00017 - APE 7112B
Association à but non lucratif enregistrée à la
Sous-Préfecture de Grasse (06) N° w061004871

Important notice

The present document can be downloaded from:

<http://www.etsi.org/standards-search>

The present document may be made available in electronic versions and/or in print. The content of any electronic and/or print versions of the present document shall not be modified without the prior written authorization of ETSI. In case of any existing or perceived difference in contents between such versions and/or in print, the prevailing version of an ETSI deliverable is the one made publicly available in PDF format at www.etsi.org/deliver.

Users of the present document should be aware that the document may be subject to revision or change of status.

Information on the current status of this and other ETSI documents is available at

<https://portal.etsi.org/TB/ETSIDeliverableStatus.aspx>

If you find errors in the present document, please send your comment to one of the following services:

<https://portal.etsi.org/People/CommitteeSupportStaff.aspx>

If you find a security vulnerability in the present document, please report it through our
Coordinated Vulnerability Disclosure Program:

<https://www.etsi.org/standards/coordinated-vulnerability-disclosure>

Notice of disclaimer & limitation of liability

The information provided in the present deliverable is directed solely to professionals who have the appropriate degree of experience to understand and interpret its content in accordance with generally accepted engineering or other professional standard and applicable regulations.

No recommendation as to products and services or vendors is made or should be implied.

In no event shall ETSI be held liable for loss of profits or any other incidental or consequential damages.

Any software contained in this deliverable is provided "AS IS" with no warranties, express or implied, including but not limited to, the warranties of merchantability, fitness for a particular purpose and non-infringement of intellectual property rights and ETSI shall not be held liable in any event for any damages whatsoever (including, without limitation, damages for loss of profits, business interruption, loss of information, or any other pecuniary loss) arising out of or related to the use of or inability to use the software.

Copyright Notification

No part may be reproduced or utilized in any form or by any means, electronic or mechanical, including photocopying and microfilm except as authorized by written permission of ETSI.

The content of the PDF version shall not be modified without the written authorization of ETSI.

The copyright and the foregoing restriction extend to reproduction in all media.

© ETSI 2022.

All rights reserved.

Contents

Intellectual Property Rights	6
Foreword.....	6
Modal verbs terminology.....	7
1 Scope	8
2 References	8
2.1 Normative references	8
2.2 Informative references.....	9
3 Definition of terms, symbols and abbreviations.....	9
3.1 Terms.....	9
3.2 Symbols.....	10
3.3 Abbreviations	10
4 Technical requirements specifications	11
4.1 Environmental profile.....	11
4.2 Conformance requirements	11
4.2.1 Rated output power.....	11
4.2.1.1 Definition	11
4.2.1.2 Limit.....	11
4.2.1.3 Conformance.....	11
4.2.2 Frequency stability.....	12
4.2.2.1 Definition	12
4.2.2.2 Limit.....	12
4.2.2.3 Conformance.....	12
4.2.3 Crest factor.....	12
4.2.3.1 Definition	12
4.2.3.2 Limit.....	12
4.2.3.3 Conformance.....	12
4.2.4 Spurious emissions	12
4.2.4.1 Definition	12
4.2.4.2 Limits	12
4.2.4.3 Conformance.....	13
4.2.5 Out-of-band emissions.....	13
4.2.5.1 Definition	13
4.2.5.2 Limit.....	14
4.2.5.3 Conformance.....	16
4.2.6 MCOFDM systems: ACLR performance	17
4.2.6.1 Definition	17
4.2.6.2 Limit.....	17
4.2.6.3 Conformance.....	17
4.2.7 MCOFDM systems: MER performance	17
4.2.7.1 Definition	17
4.2.7.2 Limit.....	17
4.2.7.3 Conformance.....	17
4.2.8 Behaviour in case of erroneous ETI signal	17
4.2.8.1 Definition	17
4.2.8.2 Limit.....	17
4.2.8.3 Conformance.....	18
4.2.9 BER-Performance degradation	18
4.2.9.1 Definition	18
4.2.9.2 Limit.....	18
4.2.9.3 Conformance.....	18
5 Testing for compliance with technical requirements.....	18
5.1 Environmental conditions for testing	18
5.2 Test modulating signal	19
5.3 Methods of measurement	19

5.3.1	Rated output power	19
5.3.1.1	Initial conditions	19
5.3.1.2	Procedure	19
5.3.1.3	Test requirements	19
5.3.2	Frequency stability	19
5.3.2.1	Initial conditions	19
5.3.2.2	Procedure	20
5.3.2.3	Test requirements	20
5.3.3	Crest factor	20
5.3.3.1	Initial conditions	20
5.3.3.2	Procedure	20
5.3.3.3	Test requirements	20
5.3.4	Spurious emissions	20
5.3.4.1	Initial conditions	20
5.3.4.2	Procedure	21
5.3.4.3	Test requirements	21
5.3.5	Out-of-band emissions	21
5.3.5.1	Initial conditions	21
5.3.5.2	Procedure	21
5.3.5.3	Test requirements	21
5.3.6	MCOFDM systems: ACLR	21
5.3.6.1	Initial conditions	21
5.3.6.2	Procedure	21
5.3.6.3	Test requirements	22
5.3.7	MCOFDM systems: MER	22
5.3.7.1	Initial conditions	22
5.3.7.2	Procedure	22
5.3.7.3	Test requirements	22
5.3.8	Behaviour in case of erroneous ETI signal	22
5.3.8.1	Initial conditions	22
5.3.8.2	Procedure	22
5.3.8.3	Test requirements	23
5.3.9	BER-Performance degradation	23
5.3.9.1	Initial conditions	23
5.3.9.2	Procedure	23
5.3.9.3	Test requirements	23
Annex A (informative):	Relationship between the present document and the essential requirements of Directive 2014/53/EU	24
Annex B (normative):	Measuring arrangements	25
B.1	Testing arrangements for antenna port measurements	25
B.1.1	Antenna port measurements	25
B.1.2	Out-of-band emissions	26
B.1.3	MCOFDM: ACLR and MER performance	26
Annex C (normative):	COFDM measuring arrangements	27
C.1	ETI errors	27
C.2	Bit Error performance measurement	27
Annex D (informative):	Practical measurement of spurious domain emissions	28
D.1	Introduction	28
D.2	Directional coupler issues	28
Annex E (informative):	Spectrum measurements	29
Annex F (informative):	MCOFDM systems	30
F.1	Introduction	30

F.2 Architecture.....	31
Annex G (informative): Maximum measurement uncertainty.....	33
Annex H (informative): Change history	34
History	35

Intellectual Property Rights

Essential patents

IPRs essential or potentially essential to normative deliverables may have been declared to ETSI. The declarations pertaining to these essential IPRs, if any, are publicly available for **ETSI members and non-members**, and can be found in ETSI SR 000 314: "*Intellectual Property Rights (IPRs); Essential, or potentially Essential, IPRs notified to ETSI in respect of ETSI standards*", which is available from the ETSI Secretariat. Latest updates are available on the ETSI Web server (<https://ipr.etsi.org/>).

Pursuant to the ETSI Directives including the ETSI IPR Policy, no investigation regarding the essentiality of IPRs, including IPR searches, has been carried out by ETSI. No guarantee can be given as to the existence of other IPRs not referenced in ETSI SR 000 314 (or the updates on the ETSI Web server) which are, or may be, or may become, essential to the present document.

Trademarks

The present document may include trademarks and/or tradenames which are asserted and/or registered by their owners. ETSI claims no ownership of these except for any which are indicated as being the property of ETSI, and conveys no right to use or reproduce any trademark and/or tradename. Mention of those trademarks in the present document does not constitute an endorsement by ETSI of products, services or organizations associated with those trademarks.

DECT™, **PLUGTESTS™**, **UMTS™** and the ETSI logo are trademarks of ETSI registered for the benefit of its Members. **3GPP™** and **LTE™** are trademarks of ETSI registered for the benefit of its Members and of the 3GPP Organizational Partners. **oneM2M™** logo is a trademark of ETSI registered for the benefit of its Members and of the oneM2M Partners. **GSM®** and the GSM logo are trademarks registered and owned by the GSM Association.

Foreword

This final draft Harmonised European Standard (EN) has been produced by ETSI Technical Committee Electromagnetic compatibility and Radio spectrum Matters (ERM), and is now submitted for the Vote phase of the ETSI standards EN Approval Procedure.

The present document has been prepared under the Commission's standardisation request C(2015) 5376 final [i.4] to provide one voluntary means of conforming to the essential requirements of Directive 2014/53/EU on the harmonisation of the laws of the Member States relating to the making available on the market of radio equipment and repealing Directive 1999/5/EC [i.1].

Once the present document is cited in the Official Journal of the European Union under that Directive, compliance with the normative clauses of the present document given in table A.1 confers, within the limits of the scope of the present document, a presumption of conformity with the corresponding essential requirements of that Directive, and associated EFTA regulations.

Proposed national transposition dates	
Date of latest announcement of this EN (doa):	3 months after ETSI publication
Date of latest publication of new National Standard or endorsement of this EN (dop/e):	6 months after doa
Date of withdrawal of any conflicting National Standard (dow):	18 months after doa

Modal verbs terminology

In the present document "**shall**", "**shall not**", "**should**", "**should not**", "**may**", "**need not**", "**will**", "**will not**", "**can**" and "**cannot**" are to be interpreted as described in clause 3.2 of the [ETSI Drafting Rules](#) (Verbal forms for the expression of provisions).

"**must**" and "**must not**" are **NOT** allowed in ETSI deliverables except when used in direct citation.

1 Scope

The present document specifies technical characteristics and methods of measurements for transmitting equipment for broadcast sound services using the Digital Audio Broadcast (DAB) modulation system operating in VHF band III (174 MHz to 240 MHz).

DAB transmissions are licensed by national administrations. The Final Acts of the CEPT T-DAB Planning Meeting Constanța, 2007 (WI95revCO07) [i.2] and the Final Acts of the Regional Radiocommunication Conference for planning of the digital terrestrial broadcasting service in parts of Regions 1 and 3, in the frequency bands 174 MHz to 230 MHz and 470 MHz to 862 MHz (RRC-06) [i.3] provide spectrum masks for Out-of-Band emissions under different conditions. These requirements are represented by four transmission cases in the present document, see table 0. The license conditions set by the national administration stipulate which transmission case (Out-of-Band spectrum mask) applies.

Table 0: Transmission cases

Case	Description	Identification in WI95revCO07	Identification in RRC-06
1	Applicable to DAB transmissions operating in areas critical for adjacent channel DAB to DAB interference, and in any case when it is necessary to protect other services operating on adjacent frequencies on a primary basis	1: critical	2: sensitive
2	Applicable to DAB transmissions when no other case applies	2: non-critical	1: non-critical
3	Applicable to DAB transmitters in exceptional circumstances to protect safety services	Critical case considering protection of distress and safety frequencies	
4	Applicable to DAB transmissions operating on a case-by-case basis in certain areas		3: sensitive in certain areas where channel 12D is in use

NOTE: The relationship between the present document and essential requirements of article 3.2 of Directive 2014/53/EU [i.1] is given in annex A.

2 References

2.1 Normative references

References are either specific (identified by date of publication and/or edition number or version number) or non-specific. For specific references, only the cited version applies. For non-specific references, the latest version of the referenced document (including any amendments) applies.

Referenced documents which are not found to be publicly available in the expected location might be found at <https://docbox.etsi.org/Reference/>.

NOTE: While any hyperlinks included in this clause were valid at the time of publication, ETSI cannot guarantee their long term validity.

The following referenced documents are necessary for the application of the present document.

- [1] ETSI EN 300 401 (V2.1.1) (01-2017): "Radio broadcasting systems; Digital Audio Broadcasting (DAB) to mobile, portable and fixed receivers".
- [2] ETSI ETS 300 799 (Edition 1) (09-1997): "Digital Audio Broadcasting (DAB); Distribution interfaces; Ensemble Transport Interface (ETI)".

2.2 Informative references

References are either specific (identified by date of publication and/or edition number or version number) or non-specific. For specific references, only the cited version applies. For non-specific references, the latest version of the referenced document (including any amendments) applies.

NOTE: While any hyperlinks included in this clause were valid at the time of publication, ETSI cannot guarantee their long term validity.

The following referenced documents are not necessary for the application of the present document but they assist the user with regard to a particular subject area.

- [i.1] Directive 2014/53/EU of the European Parliament and of the Council of 16 April 2014 on the harmonisation of the laws of the Member States relating to the making available on the market of radio equipment and repealing Directive 1999/5/EC.
- [i.2] Final Acts of the CEPT T-DAB Planning Meeting Constanța, 2007 (WI95revCO07).
- [i.3] Final Acts of the Regional Radiocommunication Conference for planning of the digital terrestrial broadcasting service in parts of Regions 1 and 3, in the frequency bands 174-230 MHz and 470-862 MHz (RRC-06).
- [i.4] Commission Implementing Decision C(2015) 5376 final of 4.8.2015 on a standardisation request to the European Committee for Electrotechnical Standardisation and to the European Telecommunications Standards Institute as regards radio equipment in support of Directive 2014/53/EU of the European Parliament and of the Council.

3 Definition of terms, symbols and abbreviations

3.1 Terms

For the purposes of the present document, the terms given in Directive 2014/53/EU [i.1] and the following apply:

Adjacent Channel Leakage Ratio (ACLR): ratio of the mean power of the DAB signal in the OFDM block at f_L to the mean power of the unoccupied OFDM block within the MCOFDM group

antenna port: port of an apparatus which is designed, in normal operation, to be connected to an antenna using coaxial cable

broadcasting service: radiocommunication service in which the transmissions are intended for direct reception by the general public

NOTE: This service may include sound transmissions, television transmissions or other types of transmission.

DAB transmitter: device comprising a DAB exciter and RF amplifier

dBc: decibels relative to the unmodulated carrier power of the emission

NOTE: In the cases which do not have a carrier, for example in some digital modulation schemes where the carrier is not accessible for measurement, the reference level equivalent to dBc is decibels relative to the mean power P.

f_H : centre frequency of the highest frequency OFDM block generated by the DAB transmitter

f_L : centre frequency of the lowest frequency OFDM block generated by the DAB transmitter

NOTE: In the case of a single block transmitter, $f_L = f_H$.

harmonic: component of order greater than 1 of the Fourier series of a periodic quantity

high power transmitter: transmitter whose rated output power is greater than 1 000 W per OFDM block

intermodulation products: unwanted frequencies resulting from intermodulation between carriers or harmonics of emission, or between any oscillations generated to produce the carrier

low power transmitter: transmitter whose rated output power is less than or equal to 25 W per OFDM block

MCOFDM group: group of OFDM blocks generated by a MCOFDM system

MCOFDM system: low power transmitter system that generates more than one OFDM block with an overall RF system filter spanning all blocks

mean power: average power supplied to the antenna port by a transmitter during an interval of time sufficiently long compared with the lowest frequency encountered in the modulation envelope taken under normal operating conditions

medium power transmitter: transmitter whose rated output power is greater than 25 W and less than or equal to 1 000 W per OFDM block

necessary bandwidth: width of the frequency band which is sufficient to ensure the transmission of information at the rate and with the quality required under specified conditions

OFDM block: group of digitally modulated carriers comprising a complete DAB ensemble

out-of-band emissions: emission on a frequency or frequencies immediately outside the necessary bandwidth which results from the modulation process, but excluding spurious emissions

rated output power: mean power that the transmitter delivers at its antenna port under specified conditions of operation

reference bandwidth: bandwidth in which the emission level is specified

RF system filter: filter connected to the output of the RF amplifier to control output spectrum

NOTE: The RF system filter may be internal or external to the transmitter casing.

spurious emissions: emissions on a frequency or frequencies which are outside the necessary bandwidth and the level of which may be reduced without affecting the corresponding transmission of information

NOTE: Spurious emissions include harmonic emissions, parasitic emissions, intermodulation products and frequency conversion products but exclude out of band emissions.

unwanted emissions: spurious emissions and out-of-band emissions

3.2 Symbols

For the purposes of the present document, the following symbols apply:

"	inch
C/N	Carrier power to Noise power density
Hz	Hertz (cycles per second)
m	metre
μ	micro, 10 ⁻⁶
V	Volt
W	Watt

3.3 Abbreviations

For the purposes of the present document, the following abbreviations apply:

ACLR	Adjacent Channel Leakage Ratio
BER	Bit Error Ratio
COFDM	Coded Orthogonal Frequency Division Multiplex
CRC	Cyclic Redundancy Check
CW	Continuous Wave
DAB	Digital Audio Broadcasting

EDI	Encapsulation of DAB Interfaces
EFTA	European Free Trade Association
EMC	ElectroMagnetic Compatibility
ETI	Ensemble Transport Interface
EUT	Equipment Under Test
MCOFDM	Multiple Coded Orthogonal Frequency Division Multiplex
MER	Modulation Error Ratio
N	Noise power
OFDM	Orthogonal Frequency Division Multiplex
OOB	Out-Of-Band
PRBS	Pseudo Random Binary Sequence
RF	Radio Frequency
RMS	Root Mean Square
SFN	Single Frequency Network
TII	Transmitter Identification Information
Tx	Transmitter
VHF	Very High Frequency

4 Technical requirements specifications

4.1 Environmental profile

The technical requirements of the present document apply under the environmental profile for operation of the equipment, which shall be in accordance with its intended use. The equipment shall comply with all the technical requirements of the present document at all times when operating within the boundary limits of the operational environmental profile defined by its intended use.

4.2 Conformance requirements

4.2.1 Rated output power

4.2.1.1 Definition

The rated output power is the mean power that the transmitter shall deliver at its antenna port.

For MCOFDM systems, the rated output power is the mean power of the highest powered OFDM block within the MCOFDM group.

Transmitters shall be categorized into one of three power classes, as follows:

- low power;
- medium power;
- high power.

4.2.1.2 Limit

The output power shall be within $\pm 0,5$ dB of the rated output power.

4.2.1.3 Conformance

Conformance tests as defined in clause 5.3.1 shall be carried out.

4.2.2 Frequency stability

4.2.2.1 Definition

The frequency stability of an emission is the variation of frequency against a predetermined time scale.

4.2.2.2 Limit

The stability of the centre frequency shall not deviate more than 10 Hz from its nominal value.

4.2.2.3 Conformance

Conformance tests as defined in clause 5.3.2 shall be carried out.

4.2.3 Crest factor

4.2.3.1 Definition

Maximum ratio of peak power to mean power levels.

4.2.3.2 Limit

The peak level of the output RF power signal shall not exceed the mean power level by more than 13 dB.

4.2.3.3 Conformance

Conformance tests as defined in clause 5.3.3 shall be carried out.

4.2.4 Spurious emissions

4.2.4.1 Definition

Emission on a frequency or frequencies which are outside the necessary bandwidth and the level of which may be reduced without affecting the corresponding transmission of information. Spurious emissions include harmonic emissions, parasitic emissions, intermodulation products and frequency conversion products but exclude out-of-band emissions.

For the purposes of the present document spurious emissions are emissions at frequencies below $f_L - 3$ MHz, where f_L is the centre frequency of the lowest frequency OFDM block, and above $f_H + 3$ MHz, where f_H is the centre frequency of the highest frequency OFDM block of the transmission, irrespective of the number of blocks employed. In the case of a single block transmitter, $f_L = f_H$.

The reference bandwidth used for spurious emissions measurements shall be as follows:

- 1 kHz between 9 kHz and 150 kHz;
- 10 kHz between 150 kHz and 30 MHz;
- 100 kHz between 30 MHz and 1 GHz;
- 1 MHz above 1 GHz.

4.2.4.2 Limits

Spurious emissions shall not exceed the values set out in table 1, shown additionally in figure 1, for the frequency range 9 kHz to 3 GHz at the output of the RF system filter.

Table 1: Spurious emissions limits

Mean power of the transmitter	Limits Mean power absolute levels (dBm) or relative levels (dBc) below the power supplied to the antenna port in the reference bandwidth (see clause 4.2.4.1)
$P < 9 \text{ dBW}$	-36 dBm
$9 \text{ dBW} \leq P < 29 \text{ dBW}$	75 dBc
$29 \text{ dBW} \leq P < 39 \text{ dBW}$	-16 dBm
$39 \text{ dBW} \leq P < 50 \text{ dBW}$	85 dBc
$50 \text{ dBW} \leq P$	-5 dBm

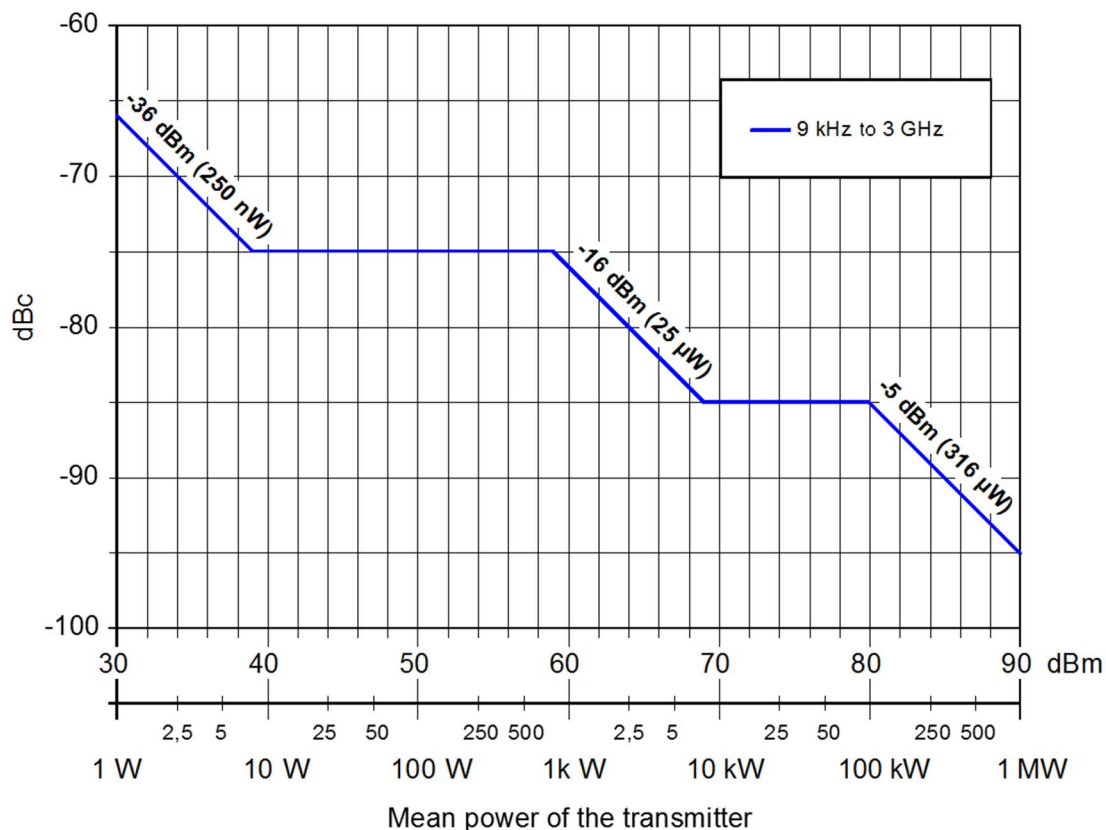

Figure 1: Spurious emissions limits for DAB transmitters

Figure 2: Void

4.2.4.3 Conformance

Conformance tests as defined in clause 5.3.4 shall be carried out.

4.2.5 Out-of-band emissions

4.2.5.1 Definition

Emission on a frequency or frequencies immediately outside the necessary bandwidth which results from the modulation process, but excludes spurious emissions.

For the purposes of the present document out-of-band emissions are emissions at frequencies outside the necessary bandwidth and within the frequency ranges $f_L - 3 \text{ MHz}$ to f_L , where f_L is the centre frequency of the lowest frequency OFDM block, and f_H to $f_H + 3 \text{ MHz}$, where f_H is the centre frequency of the highest frequency OFDM block of the transmission, irrespective of the number of blocks employed. In the case of a single block transmitter, $f_L = f_H$.

4.2.5.2 Limit

Out-of-band emissions shall not exceed the limits specified in tables 2 to 5, additionally shown in figure 3 and figure 4.

Out-of-band emissions limits are given as mean power level measured in a 4 kHz bandwidth, where 0 dB corresponds to the mean output power.

The national licence conditions specify which case the DAB transmitter shall conform to:

- Case 1: The solid line mask (see figure 3) shall apply to DAB transmitters operating in areas critical for adjacent channel DAB to DAB interference, and in any case when it is necessary to protect other services operating on adjacent frequencies on a primary basis.
- Case 2: The dashed line mask (see figure 3) shall apply to DAB transmitters in other cases.
- Case 3: The solid line mask (see figure 4) shall apply to DAB transmitters in exceptional circumstances to protect safety services.
- Case 4: The chain dotted line mask (see figure 4) shall apply to DAB transmitters operating on a case by case basis in certain areas.

Table 2: Case 1: Transmitters operating in critical cases

1,54 MHz block, frequency difference from the centre frequency (MHz)	Low power Absolute level (dBm)	Medium power Relative level (dBc)	High Power Absolute level (dBm)
±0,77	18	-26	34
±0,97	-27	-71	-11
±1,75	-62	-106	-46
±3,0	-62	-106	-46

Table 3: Case 2: Transmitters operating in non-critical cases

1,54 MHz block, frequency difference from the centre frequency (MHz)	Low power Absolute level (dBm)	Medium power Relative level (dBc)	High Power Absolute level (dBm)
±0,97	18	-26	34
±0,97	-12	-56	4
±3,0	-62	-106	-46

Table 4: Case 3: Transmitters operating in exceptional circumstances to protect safety services

1,54 MHz block, frequency difference from the centre frequency (MHz)	Low power Absolute level (dBm)	Medium power Relative level (dBc)	High Power Absolute level (dBm)
±0,77	18	-26	34
±0,97	-27	-71	-11
±2,2	-82	-126	-66
±3,0	-82	-126	-66

Table 5: Case 4: Transmitters operating on a case by case basis in certain areas

1,54 MHz block, frequency difference from the centre frequency (MHz)	Low power Absolute level (dBm)	Medium power Relative level (dBc)	High Power Absolute level (dBm)
±0,77	18	-26	34
±0,97	-34	-78	-18
±2,2	-82	-126	-66
±3,0	-82	-126	-66

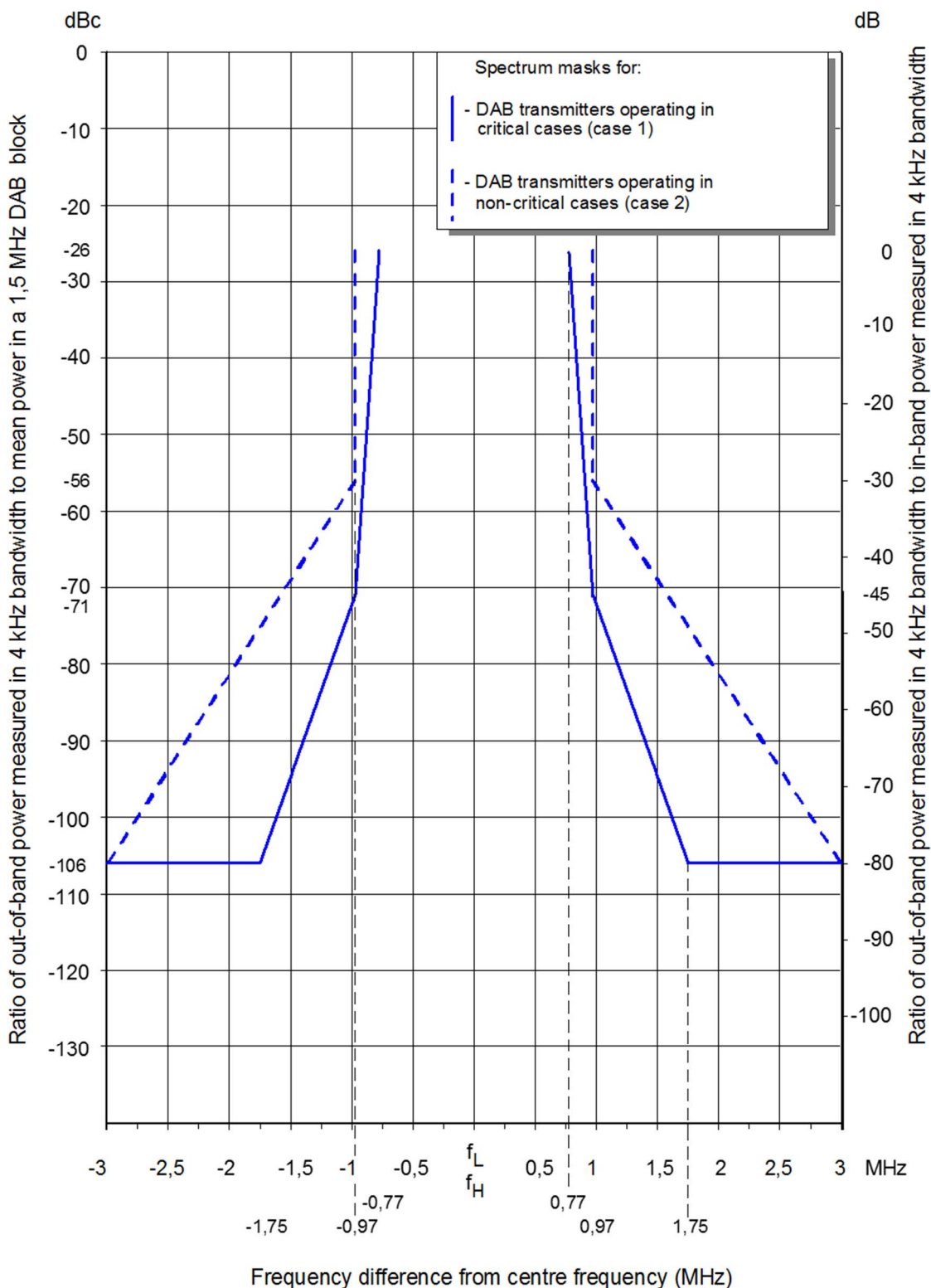

Figure 3: Spectrum masks for DAB out-of-band emissions (case 1 and case 2)

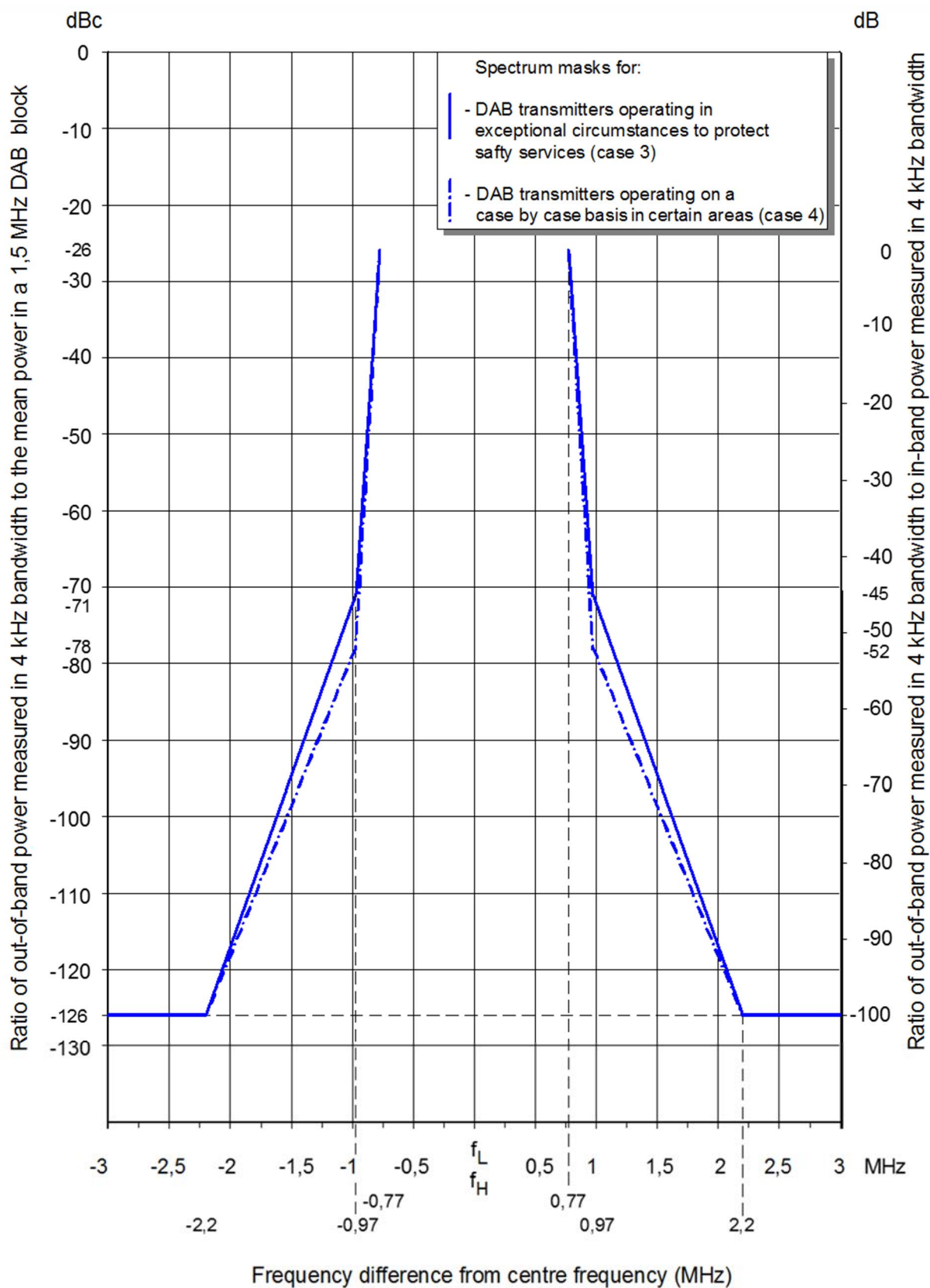

Figure 4: Spectrum masks for DAB out-of-band emissions (case 3 and case 4)

4.2.5.3 Conformance

Conformance tests as defined in clause 5.3.5 shall be carried out.

4.2.6 MCOFDM systems: ACLR performance

4.2.6.1 Definition

Adjacent channel performance required for unoccupied OFDM blocks within the MCOFDM group.

The ACLR is defined as the ratio of the mean power of the DAB signal in the OFDM block at f_L to the mean power of the unoccupied OFDM block within the MCOFDM group.

Out-of-band emissions which fall between f_L and f_H within the MCOFDM group are not influenced by the RF system filter. Every unoccupied OFDM block within the MCOFDM group shall be subject to an ACLR limit.

4.2.6.2 Limit

For each unoccupied OFDM block within the MCOFDM group, the ACLR shall be ≥ 55 dB.

4.2.6.3 Conformance

Conformance tests as defined in clause 5.3.6 shall be carried out.

4.2.7 MCOFDM systems: MER performance

4.2.7.1 Definition

MER performance required for every occupied OFDM block within the MCOFDM group.

4.2.7.2 Limit

For every occupied OFDM block within the MCOFDM group, the MER shall be ≥ 20 dB.

4.2.7.3 Conformance

Conformance tests as defined in clause 5.3.7 shall be carried out.

4.2.8 Behaviour in case of erroneous ETI signal

4.2.8.1 Definition

Operational status of transmitter during ETI signal error (see ETSI ETS 300 799 [2], clauses 4 to 8).

4.2.8.2 Limit

The minimum requirements for DAB transmitters shall be:

- $P = 4$;
- $Q = 40$;
- $M = 80$.

If the input signal is absent, or if frame synchronization is not achieved, the transmitter RF signal shall be muted in line with spurious emission limits, clause 4.2.4.2.

If frame synchronization is achieved, but CRC violations are detected, the transmitter shall offer two alternative responses:

- a) The output RF signal is not affected by sporadic single CRC violations. The output RF signal is switched off after P CRC violations in Q frames, and switched on after M consecutive frames free from CRC violations.

- b) The output RF signal is transmitted irrespective of CRC violations.

After the warming-up time of the transmitter the output RF signal shall be stable within two seconds following the application of an error-free input signal.

4.2.8.3 Conformance

Conformance tests as defined in clause 5.3.8 shall be carried out.

4.2.9 BER-Performance degradation

4.2.9.1 Definition

Difference between theoretical and actual BER degradation.

4.2.9.2 Limit

An operational transmitter shall not degrade the theoretical system BER (with channel coding and decoding) by more than 1 dB, under the conditions set out in table 6 and table 7.

Table 6: BER Performance degradation limits

Code Rate R for equal convolutional coding	0,5
Theoretical performance	according to table 7

Table 7: BER Performance degradation limits

BER	C/N
1×10^{-2}	5,0 dB
3×10^{-3}	5,4 dB
1×10^{-3}	5,8 dB
3×10^{-4}	6,2 dB
1×10^{-4}	6,6 dB
3×10^{-5}	6,9 dB
1×10^{-5}	7,2 dB
3×10^{-6}	7,5 dB
1×10^{-6}	7,8 dB

4.2.9.3 Conformance

Conformance tests as defined in clause 5.3.9 shall be carried out.

5 Testing for compliance with technical requirements

5.1 Environmental conditions for testing

Tests defined in the present document shall be carried out at representative points within the boundary limits of the operational environmental profile defined by its intended use.

Where technical performance varies subject to environmental conditions, tests shall be carried out under a sufficient variety of environmental conditions (within the boundary limits of the operational environmental profile defined by its intended use) to give confidence of compliance for the affected technical requirements.

5.2 Test modulating signal

An input signal shall be provided, according to the specification of the transmitter, to obtain a valid DAB output signal as defined in ETSI EN 300 401 [1], clause 15.

5.3 Methods of measurement

5.3.1 Rated output power

5.3.1.1 Initial conditions

Test frequencies:

- a) the lowest operating frequency of the EUT;
- b) the highest operating frequency of the EUT;
- c) a frequency mid-way between a) and b) above.

Test arrangement (see figure B.1):

- 1) all ports unused at the time of testing shall be correctly terminated;
- 2) connect the EUT to the Test Load, via the coupling device or via the attenuator;
- 3) connect the spectrum analyser or power meter to the coupling device or attenuator.

5.3.1.2 Procedure

- 1) operate the EUT at each of the test frequencies as defined in clause 5.3.1.1;
- 2) measure the results on the spectrum analyser or power meter.

The power of the signal of a DAB transmitter is defined as the long-term average of the time-varying short-term signal power. An appropriate instrument for DAB power measurements is a thermal power meter. The signal power is constant symbol by symbol. A certain short-term variation is especially given by the Null symbol.

5.3.1.3 Test requirements

The results obtained shall be compared to the limits in clause 4.2.1.2 in order to demonstrate compliance.

5.3.2 Frequency stability

5.3.2.1 Initial conditions

Test frequencies:

- Any one frequency within the tuning range of the EUT.

Test arrangement (see figure B.1):

- 1) all ports unused at the time of testing shall be correctly terminated;
- 2) connect the EUT to the Test Load, via the Coupling Device or via the attenuator;
- 3) connect the measuring device to the Coupling Device or attenuator.

5.3.2.2 Procedure

- 1) Operate the exciter of the EUT at the test frequency as defined in clause 5.3.2.1.
- 2) Measure the maximum deviation on the frequency recorder over a 5 minute period.

5.3.2.3 Test requirements

The results obtained shall be compared to the limits in clause 4.2.2.2 in order to demonstrate compliance.

5.3.3 Crest factor

5.3.3.1 Initial conditions

Test frequencies:

- a) the lowest operating frequency of the EUT;
- b) the highest operating frequency of the EUT;
- c) a frequency mid-way between a) and b) above.

Test arrangement (see figure B.1):

- 1) all ports unused at the time of testing shall be correctly terminated;
- 2) connect the EUT to the Test Load, via the Coupling Device or attenuator;
- 3) connect the measuring device to the Coupling Device or attenuator.

5.3.3.2 Procedure

Using a suitable measuring device first record the peak power then record the mean power.

5.3.3.3 Test requirements

The results obtained shall be compared to the limits in clause 4.2.3.2 in order to demonstrate compliance.

5.3.4 Spurious emissions

5.3.4.1 Initial conditions

Test frequencies:

- a) the lowest operating frequency of the EUT;
- b) the highest operating frequency of the EUT;
- c) a frequency mid-way between a) and b) above.

Test arrangement (see figure B.1):

- 1) all ports unused at the time of testing shall be correctly terminated;
- 2) connect the EUT to the Test Load, via the Coupling Device or via the attenuator;
- 3) connect the measuring device to the Coupling Device or attenuator.

5.3.4.2 Procedure

- 1) Operate the EUT at each of the test frequencies as defined in clause 5.3.4.1.
- 2) Measure the results on the Spectrum Analyser.

5.3.4.3 Test requirements

The results obtained shall be compared to the limits in clause 4.2.4.2 in order to demonstrate compliance.

5.3.5 Out-of-band emissions

5.3.5.1 Initial conditions

Test frequencies:

- a) the lowest operating frequency of the EUT;
- b) the highest operating frequency of the EUT;
- c) a frequency mid-way between a) and b) above.

Test arrangement (see figure B.2).

5.3.5.2 Procedure

- 1) All ports unused at the time of testing shall be correctly terminated.
- 2) Operate the EUT at each of the test frequencies as defined in clause 5.3.5.1.
- 3) Measure the results on the Spectrum Analyser.

5.3.5.3 Test requirements

The results obtained shall be compared to the limits in clause 4.2.5.2 in order to demonstrate compliance.

5.3.6 MCOFDM systems: ACLR

5.3.6.1 Initial conditions

Test frequencies:

- a) the centre frequency of the OFDM block closest to the frequency midway between the lowest and highest possible frequencies of the EUT; if two OFDM blocks fulfill this requirement, then the lower frequency OFDM block shall be used.

Test arrangement (see figure B.3):

The OFDM block at the test frequency shall be unoccupied. All other OFDM blocks shall be operated at the full rated output power of the transmitter during this test.

5.3.6.2 Procedure

- 1) Connect the EUT to the Test Load, via the Coupling Device.
- 2) Measure the mean power of the OFDM block centred at f_L .
- 3) Measure the mean power of the OFDM block centred at the test frequency.
- 4) Calculate the ACLR as the ratio of the two powers.

The mean power shall be measured in a 3 kHz bandwidth over the integration bandwidth of 1,712 MHz for both the occupied and unoccupied OFDM blocks.

The ACLR can be measured directly on some spectrum analysers, but off-line calculation by a numerical linear power sum of the trace data may be required in other cases.

5.3.6.3 Test requirements

The results obtained shall be compared to the limits in clause 4.2.6.2 in order to demonstrate compliance.

5.3.7 MCOFDM systems: MER

5.3.7.1 Initial conditions

Test frequencies:

- a) the operating frequency of each OFDM block of the EUT.

Test arrangement (see figure B.1):

All OFDM blocks are operated at the full rated output power of the transmitter during this test.

5.3.7.2 Procedure

- 1) Connect the EUT to the Test Load, via the Coupling Device.
- 2) MER can be measured directly with a suitable DAB enabled RF analyser or decoder. The analyser should be connected to a suitable low level RF coupling device on the antenna or test load port after the EUT RF system filter.

5.3.7.3 Test requirements

The results obtained shall be compared to the limits in clause 4.2.7.2 in order to demonstrate compliance.

5.3.8 Behaviour in case of erroneous ETI signal

5.3.8.1 Initial conditions

Test frequencies:

- Any one frequency within the tuning range of the EUT.

Test arrangement (see clause C.1).

- 1) All ports unused at the time of testing shall be correctly terminated.
- 2) Connect the EUT to the Test Load, via the Coupling Device or via the attenuator.
- 3) Connect the measuring device to the Coupling Device or attenuator.

5.3.8.2 Procedure

- 1) Connect the EUT to the Test Load, via the Coupling Device.
- 2) Connect the ETI replayer (see clause C.1) to the EUT to create an errored ETI input.
- 3) Measure the muting and recovery of the EUT with a suitable DAB enabled RF analyser or decoder. The analyser should be connected to a suitable low level RF coupling device on the antenna or test load port after the EUT RF system filter.

5.3.8.3 Test requirements

The results obtained shall be compared to the limits in clause 4.2.8.2 in order to demonstrate compliance.

5.3.9 BER-Performance degradation

5.3.9.1 Initial conditions

Test frequencies:

- Any one frequency within the tuning range of the EUT.

Test arrangement (see clause C.2).

The receiver is connected to the output of the transmitter. Error correction shall be enabled in both the EUT and the receiver. Band limited noise is added to the DAB signal at the receiver input in order to achieve a given value of BER. Adjustable attenuators are used to set both the input power (C) and the noise power (N) to appropriate values at the input of the receiver. BER is the ratio of erroneous bits of the received data to the total bits of the received data during the measurement interval. The power of the added noise, N, is measured within the nominal DAB bandwidth of 1,536 MHz.

5.3.9.2 Procedure

- 1) Connect the EUT to the test load, via the coupling device.
- 2) Run the EUT for at least 30 min at its nominal power.
- 3) Set the spectrum analyser centre frequency to the Tx frequency, span to 5 MHz, reference bandwidth to 30 kHz, video bandwidth to 100 Hz.
- 4) Make sure that the internal noise of the analyser is less than 25 dB below the noise source output. Make sure that the analyser is not overloaded.
- 5) Adjust the variable attenuator and/or the noise source output until the spectrum analyser shows the desired $(C + N_0)/N_0$. Use the marker to read the results from the analyser.

EXAMPLE: For 5 dB C/No, the DAB signal on the analyser display is 6,2 dB above the noise level.

- 6) Set the EUT and the DAB receiver according to figure C.2.
- 7) The Bit Error Ratio is displayed on the BER analyser.

5.3.9.3 Test requirements

The results obtained shall be compared to the limits in clause 4.2.9.2 in order to demonstrate compliance.

Annex A (informative): Relationship between the present document and the essential requirements of Directive 2014/53/EU

The present document has been prepared under the Commission's standardisation request C(2015) 5376 final [i.4] to provide one voluntary means of conforming to the essential requirements of Directive 2014/53/EU on the harmonisation of the laws of the Member States relating to the making available on the market of radio equipment and repealing Directive 1999/5/EC [i.1].

Once the present document is cited in the Official Journal of the European Union under that Directive, compliance with the normative clauses of the present document given in table A.1 confers, within the limits of the scope of the present document, a presumption of conformity with the corresponding essential requirements of that Directive, and associated EFTA regulations.

Table A.1: Relationship between the present document and the essential requirements of Directive 2014/53/EU [i.1]

Harmonised Standard ETSI EN 302 077					
Requirement				Requirement Conditionality	
No	Description	Essential requirements of Directive	Clause(s) of the present document	U/C	Condition
1	Rated output power	3.2	4.2.1	U	
2	Frequency stability	3.2	4.2.2	U	
3	Crest factor	3.2	4.2.3	U	
4	Spurious emissions	3.2	4.2.4	U	
5	Out-of-band emissions	3.2	4.2.5	U	
6	MCOFDM ACLR	3.2	4.2.6	C	MCOFDM transmitter
7	MCOFDM MER	3.2	4.2.7	C	MCOFDM transmitter
8	Behaviour in case of erroneous ETI signal	3.2	4.2.8	U	
9	BER-Performance degradation	3.2	4.2.9	U	

Key to columns:

Requirement:

No A unique identifier for one row of the table which may be used to identify a requirement.

Description A textual reference to the requirement.

Essential requirements of Directive

Identification of article(s) defining the requirement in the Directive.

Clause(s) of the present document

Identification of clause(s) defining the requirement in the present document unless another document is referenced explicitly.

Requirement Conditionality:

U/C Indicates whether the requirement is unconditionally applicable (U) or is conditional upon the manufacturer's claimed functionality of the equipment (C).

Condition Explains the conditions when the requirement is or is not applicable for a requirement which is classified "conditional".

Presumption of conformity stays valid only as long as a reference to the present document is maintained in the list published in the Official Journal of the European Union. Users of the present document should consult frequently the latest list published in the Official Journal of the European Union.

Other Union legislation may be applicable to the product(s) falling within the scope of the present document.

Annex B (normative): Measuring arrangements

B.1 Testing arrangements for antenna port measurements

B.1.1 Antenna port measurements

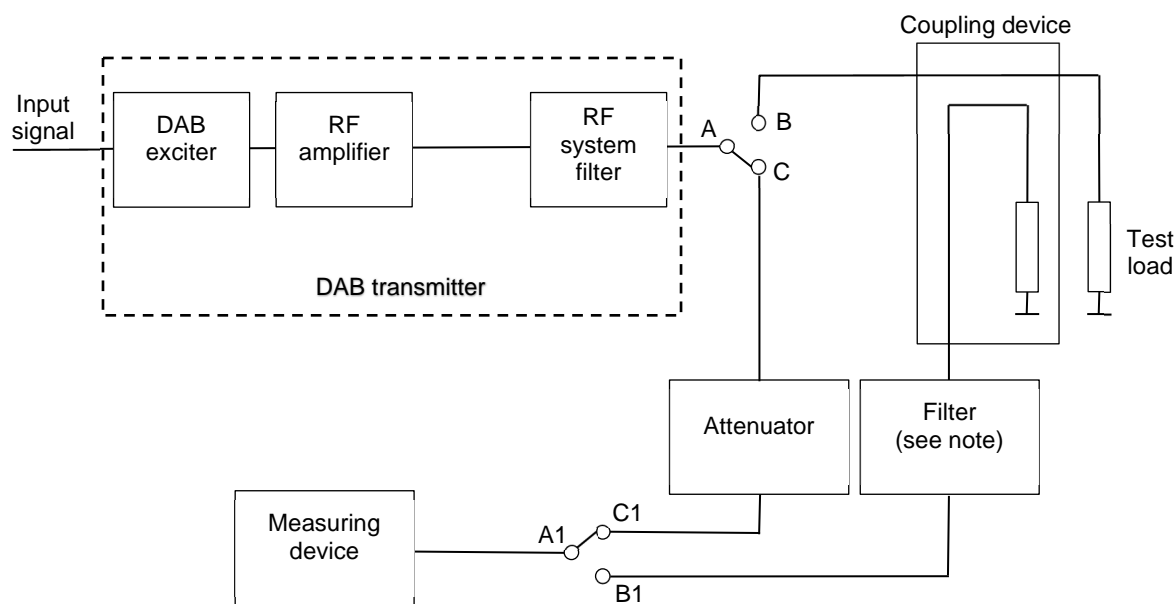

For high and medium power transmitters the preferred set up requires A to be connected to B and A1 to be connected to B1.

For low power transmitters the preferred set up requires A to be connected to C and A1 to be connected to C1.

NOTE: The filter shall suppress the output signal so that no intermodulation products are generated by the measuring device. The insertion loss throughout the measuring range shall be known.

Figure B.1: Testing arrangement for antenna port measurements

B.1.2 Out-of-band emissions

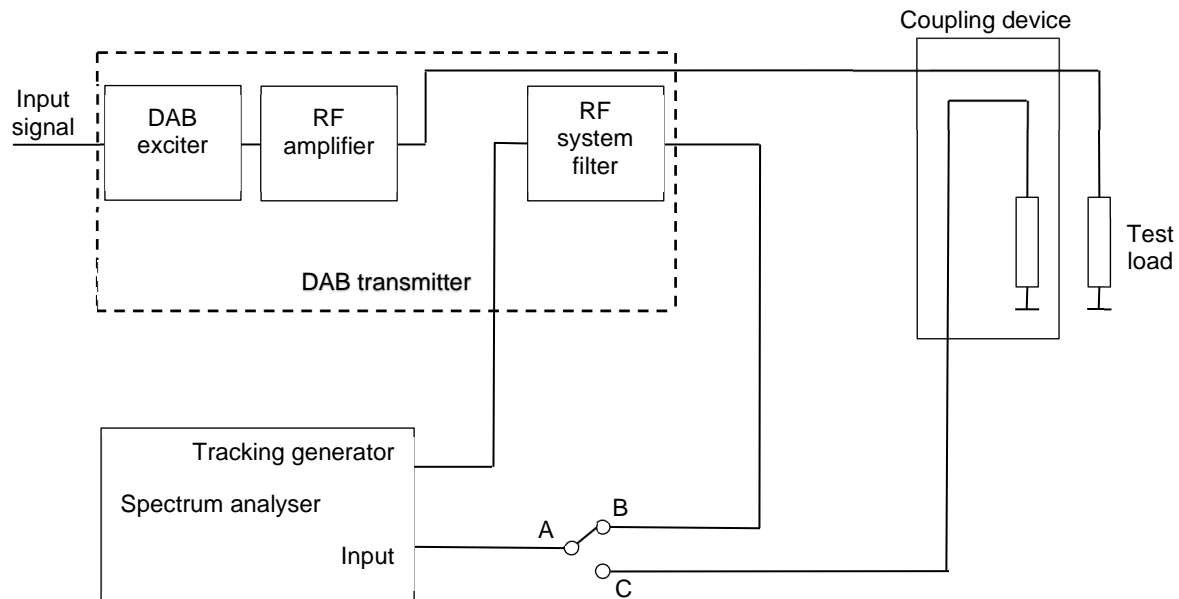

To overcome dynamic range limitations of typical spectrum analysers, a composite measurement approach is proposed as follows:

- Disconnect the RF system filter from the RF amplifier.
- Set the switch to position A - B to measure and record the frequency response of the RF system filter.
- Set the switch to position A - C to measure and record the spectrum of the DAB signal at the output of the RF amplifier.
- The out-of-band spectrum shall be calculated by applying the recorded frequency response of the RF system filter to the recorded spectrum of the RF amplifier.

Figure B.2: Testing arrangement for out-of-band emissions

B.1.3 MCOFDM: ACLR and MER performance

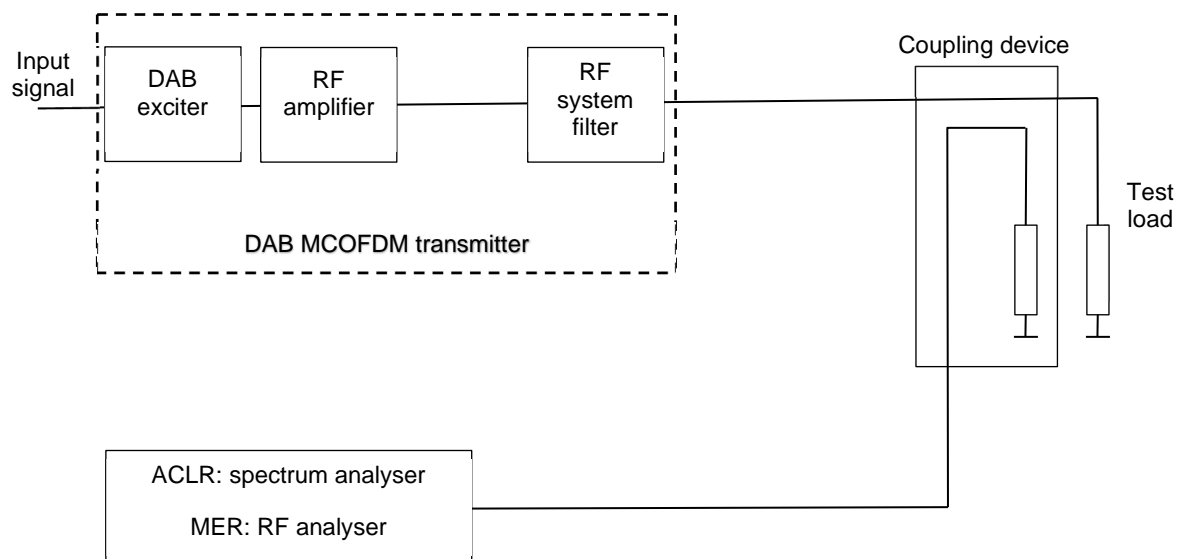

Figure B.3: Testing arrangement for MCOFDM ACLR and MER performance

Annex C (normative): COFDM measuring arrangements

C.1 ETI errors

The test arrangement is shown in figure C.1.



Figure C.1: ETI Test arrangement

C.2 Bit Error performance measurement

The test arrangement is shown in figure C.2.

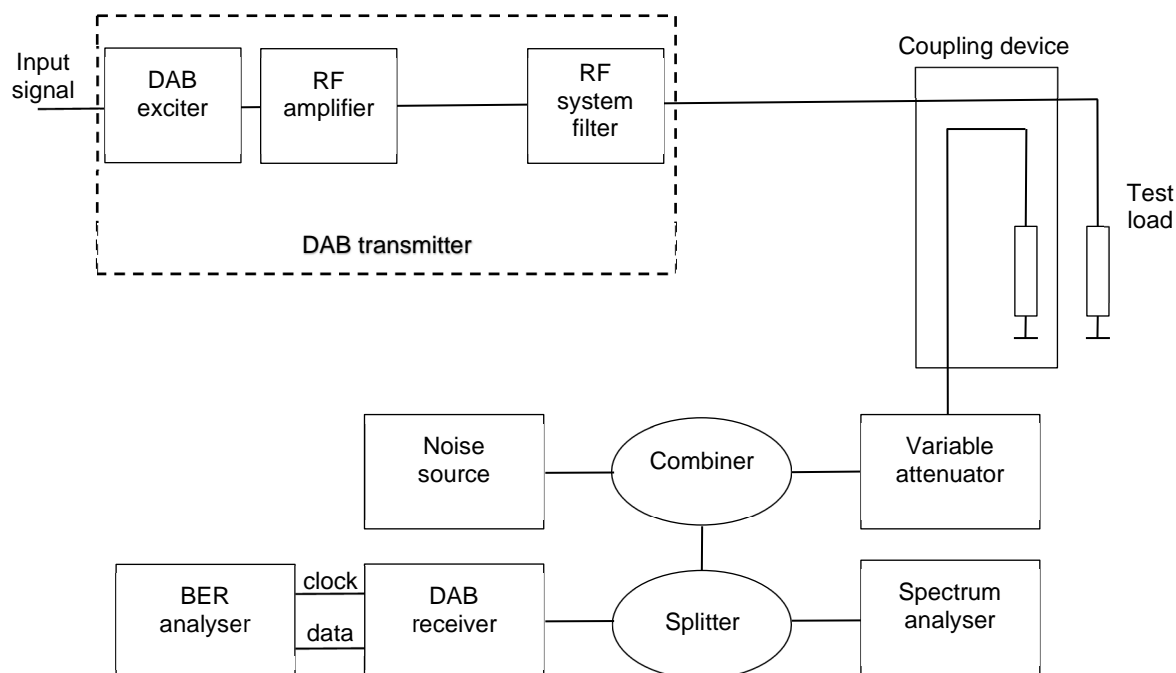

Figure C.2: Bit error performance measurement

Annex D (informative): Practical measurement of spurious domain emissions

D.1 Introduction

The accurate measurement of spurious domain emissions is typically limited by the dynamic range of the spectrum analyser. It is usually necessary to use additional band-reject, low pass or high pass filters to remove the fundamental signal in order to reveal the unwanted spurious domain emissions.

D.2 Directional coupler issues

Measurements on live equipment connected to broadcast antennas are further complicated by practical issues relating to the couplers used to probe the transmitter output signal. These typically exhibit a frequency dependent response which is expected to be accounted for in the measurement. Directional couplers usually exhibit a response whereby the coupling factor increases 6 dB per octave as shown in figure D.1 for a device for use with a 1 5/8 " feeder.

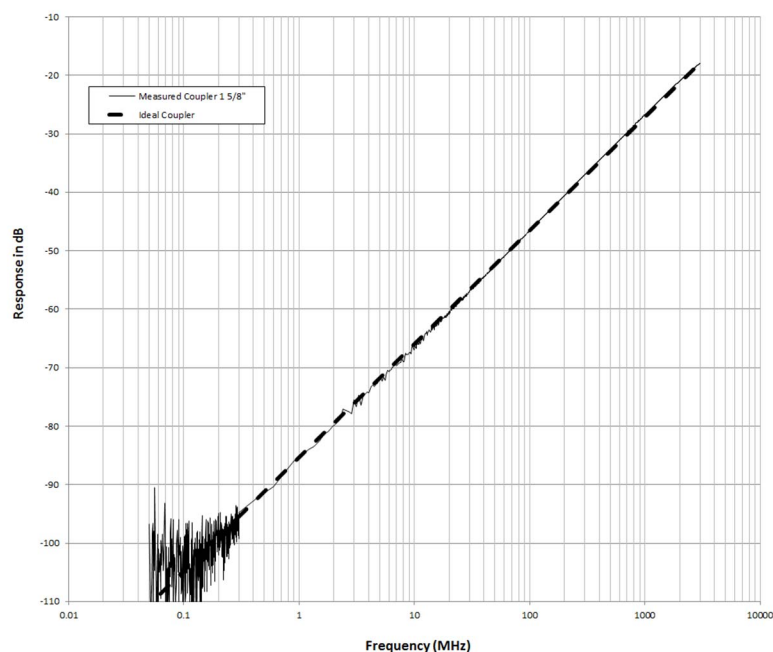

Figure D.1: Typical Measured Directional Coupler Frequency Response (1 5/8 " feeder)

At low frequencies, the decreasing coupling factor results in a low signal level and the spurious domain measurement will typically be limited by the noise floor of the spectrum analyser.

The RF transmission response seen in figure D.1 shows very low coupling factors at low frequencies and higher coupling factors at frequencies above the operating channel. In order to overcome this effect a composite measurement approach can be adopted as follows:

- The levels of the spurious emissions at the output of the channel filter/RF combiner may be calculated by weighting the measured result with the frequency response of the coupler. This calculation can be carried out off-line.

Annex E (informative): Spectrum measurements

The spectrum mask is defined in relation to spectrum density measured in 4 kHz bandwidth.

The spectral density of a DAB signal is defined as the long-term average of the time-varying signal power per unity bandwidth (i.e. 1 Hz). Values for other bandwidths can be achieved by proportional increase of the values for unity bandwidth.

The spectral density of a DAB signal can in principle be determined by the following procedure:

- The DAB signal is applied to a band filter with rectangular passband characteristics and a known bandwidth (typically 10 kHz) and with an adjustable centre frequency. The output of the filter is measured by a power meter that delivers real mean values and integrates as long as necessary (typically 2 transmission frames) to get constant readings. These readings can be interpreted as the average spectral density for the measurement bandwidth used. By moving the centre frequency step by step across the DAB signal and adjacent frequency regions the frequency dependent average of the spectral density can be found. The derivation of the average spectrum density for the unity bandwidth is straightforward. In practice, such measurements are often performed by using a spectrum analyser. It has to be analysed to what extent the device follows the principles given above. In particular, equivalent noise bandwidth and RMS measurement need to be carefully checked.

Due to the prolongation of the COFDM symbol by the guard interval the spectral density inside the nominal bandwidth varies by about 3 dB with a periodicity of the carrier distance. This variation can only be observed in its entirety if the bandwidth of the spectral density measurement filter is low compared to the carrier distance (the carrier distance is mode-dependent). Low measurement bandwidth allows detection of small CW components within the COFDM spectrum. Those components that fall outside the nominal DAB frequency block should be treated separately from the COFDM signal as their impairment effect may be different.

To avoid regular structures in the modulated signal a non-regular, e.g. a PRBS like or a programme type digital transmitter-input signal, is necessary.

Care has to be taken that the input stage of the selective measurement equipment is not overloaded by the main lobe of the signal while assessing the spectral density of the side lobes, i.e. the out-of-band range. Especially in cases with very strong attenuation of the side lobes non-linear distortion in the measurement equipment can produce side lobe signals that mask the original ones. Selective attenuation of the main lobe has proven to be a way to avoid this masking effect. However, as the frequency response of the band-stop filter has to be included in the evaluation the whole measurement procedure may become somewhat complex.

Annex F (informative): MCOFDM systems

F.1 Introduction

A traditional DAB transmitter generates and amplifies a single OFDM block. However, with the further development of DAB networks, lower cost filler transmitters are desirable, and the ability to generate and amplify multiple OFDM blocks within the same transmitter becomes attractive. An MCOFDM system fulfills this need.

An MCOFDM system allows a number of adjacent OFDM blocks to be generated and amplified. The power of each OFDM block within the MCOFDM group may be different, and some OFDM blocks may not be occupied. Some example arrangements are shown in figure F.1.

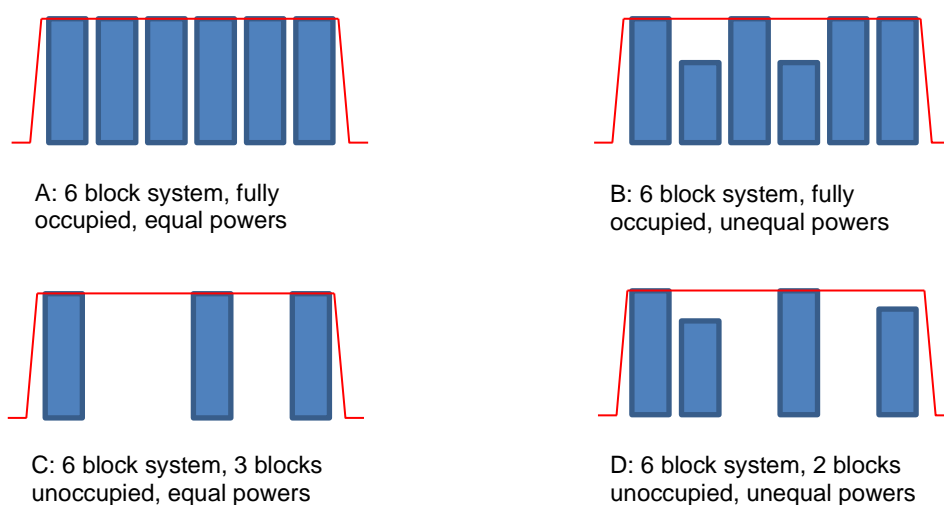

Figure F.1: Example MCOFDM systems

The requirements for spurious and OOB emissions from an MCOFDM system are the same as for traditional DAB transmitters, based on the block edge characteristics, as shown in figure F.2.

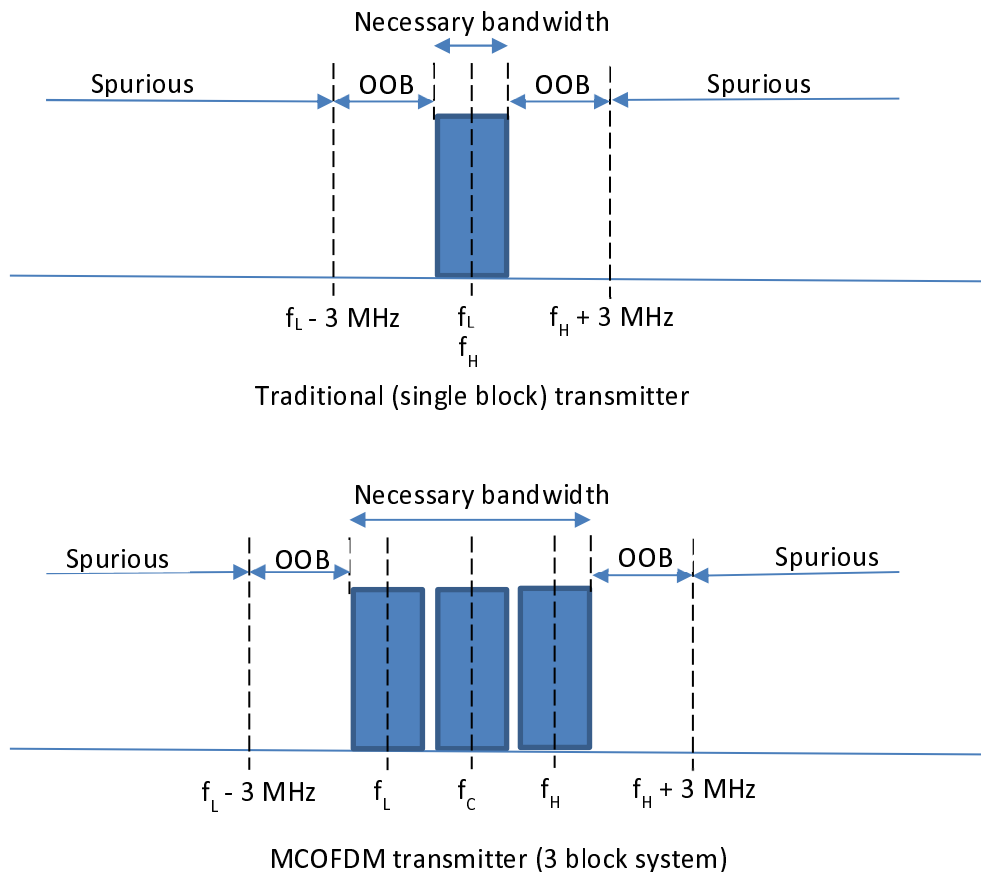

Figure F.2: Frequency bands of spurious and OOB emissions and necessary bandwidth

F.2 Architecture

The MCOFDM signal chain consists of the same three elements as a traditional single OFDM block transmission system, that is an exciter, RF amplifier and RF system filter.

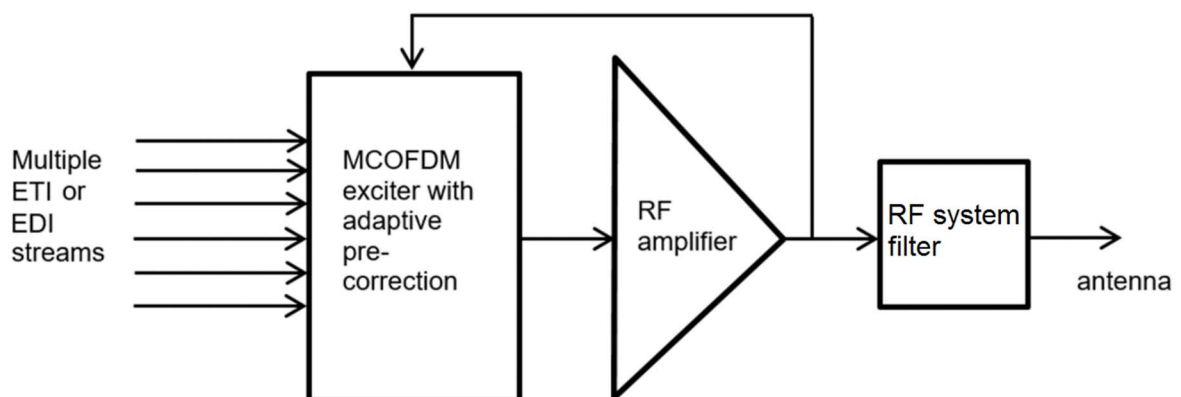

Figure F.3: Typical MCOFDM architecture

The MCOFDM exciter is fed with multiple ETI or EDI feeds and generates a group of DAB OFDM blocks. Each block can be individually configured, allowing parameters such as SFN timing, TII, etc. to be set.

The composite group of OFDM blocks is then passed through a single amplifier chain (with suitable digital adaptive non-linear and linear pre-correction).

The MCOFDM output from the RF amplifier is then passed through an RF band-pass system filter. The filter amplitude response is set to provide sufficient bandwidth in order to pass the group of OFDM blocks with low loss. Stop band attenuation provides suppression beyond the upper and lower edges of the group of blocks. Since the RF system filter passes the entire MCOFDM group, the attenuation of unoccupied OFDM blocks within the group is performed in the exciter.

Annex G (informative): Maximum measurement uncertainty

The measurements described in the present document are based on the following assumptions:

- the measured value related to the corresponding limit will be used to decide whether an equipment meets the requirements of the present document;
- the value of the measurement uncertainty for the measurement of each parameter is included in the test report.

Table G.1 shows the recommended values for the maximum measurement uncertainty figures.

Table G.1: Maximum measurement uncertainty

Parameter	Uncertainty
Rated output power (conducted)	0,75 dB
Frequency stability	0,1 Hz
Crest factor	0,75 dB
Spurious emissions (conducted emissions)	3,0 dB
Out-of-band emissions (conducted emissions)	3,0 dB
MCOFDM systems: ACLR	0,75 dB
MCOFDM systems: MER	0,75 dB

Annex H (informative): Change history

Version	Information about changes
2.1.1	First published version covering Directive 2014/53/EU Major changes are: <ul style="list-style-type: none">• Introduction of MCOFDM systems• Removal of cabinet radiation testing (transferred to EMC testing)
2.2.1	Second published version covering Directive 2014/53/EU. Minor changes are: <ul style="list-style-type: none">• Revision of limits for spurious emissions to fully align with ERC Recommendation 74-01;• Revision of parts of clause 5.3 to provide greater clarity of procedures.

History

Document history		
V1.1.1	January 2005	Publication as ETSI EN 302 077 parts 1 and 2
V2.1.1	June 2018	Publication
V2.2.0	February 2022	EN Approval Procedure AP 20220519: 2022-02-18 to 2022-05-19
V2.3.0	July 2022	Vote V 20220830: 2022-07-01 to 2022-08-30