

Draft **ETSI EN 302 065** V1.2.1 (2009-12)

---

*Harmonized European Standard (Telecommunications series)*

**Electromagnetic compatibility and  
Radio spectrum Matters (ERM);  
Short Range Devices (SRD) using  
Ultra Wide Band technology (UWB)  
for communications purposes;  
Harmonized EN covering essential requirements  
of article 3.2 of the R&TTE Directive**

---



---

Reference

REN/ERM-TGUWB-0118-1

---

Keywords

radio, SRD, testing, UWB

**ETSI**

650 Route des Lucioles  
F-06921 Sophia Antipolis Cedex - FRANCE

Tel.: +33 4 92 94 42 00 Fax: +33 4 93 65 47 16

Siret N° 348 623 562 00017 - NAF 742 C  
Association à but non lucratif enregistrée à la  
Sous-Préfecture de Grasse (06) N° 7803/88

---

**Important notice**

Individual copies of the present document can be downloaded from:

<http://www.etsi.org>

The present document may be made available in more than one electronic version or in print. In any case of existing or perceived difference in contents between such versions, the reference version is the Portable Document Format (PDF). In case of dispute, the reference shall be the printing on ETSI printers of the PDF version kept on a specific network drive within ETSI Secretariat.

Users of the present document should be aware that the document may be subject to revision or change of status. Information on the current status of this and other ETSI documents is available at

<http://portal.etsi.org/tb/status/status.asp>

If you find errors in the present document, please send your comment to one of the following services:

[http://portal.etsi.org/chaicor/ETSI\\_support.asp](http://portal.etsi.org/chaicor/ETSI_support.asp)

---

**Copyright Notification**

No part may be reproduced except as authorized by written permission.  
The copyright and the foregoing restriction extend to reproduction in all media.

© European Telecommunications Standards Institute 2009.  
All rights reserved.

**DECT**<sup>™</sup>, **PLUGTESTS**<sup>™</sup>, **UMTS**<sup>™</sup>, **TIPHON**<sup>™</sup>, the TIPHON logo and the ETSI logo are Trade Marks of ETSI registered for the benefit of its Members.

**3GPP**<sup>™</sup> is a Trade Mark of ETSI registered for the benefit of its Members and of the 3GPP Organizational Partners.

**LTE**<sup>™</sup> is a Trade Mark of ETSI currently being registered

for the benefit of its Members and of the 3GPP Organizational Partners.

**GSM**<sup>®</sup> and the GSM logo are Trade Marks registered and owned by the GSM Association.

# Contents

Intellectual Property Rights .....	6
Foreword.....	6
Introduction .....	7
1 Scope .....	9
2 References .....	9
2.1 Normative references .....	10
2.2 Informative references.....	10
3 Definitions, symbols and abbreviations .....	11
3.1 Definitions .....	11
3.2 Symbols.....	12
3.3 Abbreviations .....	12
4 Technical requirements specification.....	13
4.1 Technical requirements .....	13
4.1.1 Operating bandwidth.....	13
4.1.1.1 Definition .....	13
4.1.1.2 Test procedure.....	13
4.1.1.3 Limit.....	13
4.1.1.4 Measurement uncertainty .....	14
4.1.2 Maximum value of mean power spectral density .....	14
4.1.2.1 Definition .....	14
4.1.2.2 Test procedure.....	14
4.1.2.3 Limit.....	14
4.1.2.4 Maximum allowable measurement uncertainty.....	15
4.1.3 Maximum value of peak power .....	15
4.1.3.1 Definition .....	15
4.1.3.2 Test procedure.....	15
4.1.3.3 Limit.....	15
4.1.3.4 Maximum allowable measurement uncertainty.....	16
4.1.4 Transmit Power Control.....	16
4.1.4.1 Definition .....	16
4.1.4.2 Test procedure.....	16
4.1.4.3 Limit.....	17
4.1.4.4 Maximum allowable measurement uncertainty.....	17
4.1.5 Receiver spurious emissions .....	17
4.1.5.1 Definition .....	17
4.1.5.2 Test procedure.....	17
4.1.5.3 Limit.....	17
4.1.5.4 Maximum allowable measurement uncertainty.....	18
4.1.6 Detect-And-Avoid (DAA) .....	18
4.1.6.1 Introduction .....	18
4.1.6.1.1 Applicable frequency ranges .....	18
4.1.6.1.2 DAA operational modes .....	18
4.1.6.2 Test procedure.....	19
4.1.6.3 Limit.....	19
4.1.6.4 Maximum allowable measurement uncertainty.....	19
4.1.7 Low Duty Cycle (LDC) .....	19
4.1.7.1 Definitions.....	19
4.1.7.2 Test procedure.....	19
4.1.7.3 Limits .....	19
4.1.8 Equivalent mitigation techniques.....	20
5 Essential radio test suites.....	20
5.1 Product information.....	20
5.2 Requirements for the test modulation.....	21

5.3	Test conditions, power supply and ambient temperatures .....	21
5.3.1	Test conditions .....	21
5.3.2	Power sources .....	21
5.3.2.1	Power sources for stand-alone equipment .....	21
5.3.2.2	Power sources for plug-in radio devices .....	21
5.3.3	Normal test conditions .....	22
5.3.3.1	Normal temperature and humidity .....	22
5.3.3.2	Normal power source .....	22
5.3.3.2.1	Mains voltage .....	22
5.3.3.2.2	Lead-acid battery power sources used on vehicles .....	22
5.3.3.2.3	Other power sources .....	22
5.4	Choice of equipment for test suites .....	22
5.4.1	Choice of model .....	22
5.4.2	Presentation .....	22
5.4.3	Operating bandwidth .....	22
5.4.4	Test sites and general arrangements for radiated measurements .....	23
5.5	Testing of host connected equipment and plug-in radio devices .....	23
5.5.1	The use of a host or test fixture for testing plug-In radio devices .....	23
5.5.2	Testing of combinations .....	23
5.5.2.1	Alternative A: General approach for combinations .....	23
5.5.2.2	Alternative B: For host equipment with a plug-in radio device .....	23
5.5.2.3	Alternative C: For combined equipment with a plug-in radio device .....	24
5.6	Interpretation of the measurement results .....	24
5.6.1	Measurement uncertainty is equal to or less than maximum acceptable uncertainty .....	24
5.6.2	Measurement uncertainty is greater than maximum acceptable uncertainty .....	25
5.7	Other emissions .....	25
5.8	Test procedures for essential radio test suites .....	25
5.8.1	General .....	25
5.8.2	Maximum mean power spectral density .....	25
5.8.3	Maximum peak power .....	27
5.8.4	Operating bandwidth .....	27
5.8.5	Receiver spurious emissions .....	28
5.8.6	Low Duty Cycle .....	28
5.8.7	Test Procedure for the radiolocation systems DAA test .....	28
5.8.7.1	Introduction .....	28
5.8.7.2	Start-up test .....	30
5.8.7.2.1	Test without a radiolocation test signal during the <i>Minimum Initial Channel Availability</i> <i>Check Time, <math>T_{\text{avail\_time\_min}}</math></i> .....	30
5.8.7.2.2	Tests with a radiolocation test signal at the beginning of the <i>Minimum Initial Channel</i> <i>Availability Check Time, <math>T_{\text{avail\_time\_min}}</math></i> .....	31
5.8.7.2.3	Tests with radiolocation test signal at the end of the <i>Minimum Initial Channel Availability</i> <i>Check Time, <math>T_{\text{avail\_time\_min}}</math></i> .....	33
5.8.7.3	In-operation test .....	35
5.8.7.3.1	In-operation test procedure .....	35
5.8.7.4	Test patterns for the radiolocation DAA test .....	36
5.8.8	Test Procedure for BWA systems in the band 3,4 GHz to 3,8 GHz .....	37
5.8.8.1	Introduction .....	37
5.8.8.1.1	UWB radio devices with and without victim service identification .....	37
5.8.8.2	Initial start-up test .....	37
5.8.8.2.1	Test without a BWA test signal during the <i>Minimum Initial Channel Availability Check</i> <i>Time, <math>T_{\text{avail\_time\_min}}</math></i> .....	38
5.8.8.2.2	Tests with a BWA test signal at the beginning of the <i>Minimum Initial Channel Availability</i> <i>Check Time, <math>T_{\text{avail\_time}}</math></i> .....	38
5.8.8.2.3	Tests with a BWA test signal at the end of the <i>Minimum Initial Channel Availability Check</i> <i>Time, <math>T_{\text{avail\_time}}</math></i> .....	40
5.8.8.3	In-operation test .....	41
5.8.8.4	Test Patterns for BWA Testing .....	42
<b>Annex A (normative):</b>	<b>HS Requirements and conformance Test specifications Table (HS-RTT) .....</b>	<b>44</b>
<b>Annex B (normative):</b>	<b>Radiated measurements .....</b>	<b>47</b>

B.1	Test sites and general arrangements for measurements involving the use of radiated fields .....	47
B.1.1	Anechoic chamber .....	47
B.1.2	Anechoic chamber with a conductive ground plane .....	48
B.1.3	Test antenna.....	50
B.1.4	Substitution antenna .....	50
B.1.5	Measuring antenna .....	50
B.2	Guidance on the use of a radiation test site .....	50
B.2.1	Verification of the test site .....	50
B.2.2	Preparation of the EUT.....	51
B.2.3	Power supplies to the EUT .....	51
B.2.4	Range length.....	51
B.2.5	Site preparation .....	52
B.3	Coupling of signals.....	52
B.3.1	General .....	52
B.3.2	Data Signals.....	52
B.4	Standard test methods.....	52
B.4.1	Calibrated setup.....	52
B.4.2	Substitution method.....	53
B.5	Standard calibration method.....	54
<b>Annex C (normative):</b>	<b>Conducted measurements for DAA testing .....</b>	<b>56</b>
<b>Annex D (informative):</b>	<b>Measurement antenna and preamplifier specifications .....</b>	<b>57</b>
<b>Annex E (normative):</b>	<b>Radiolocation services in the band 3,1 GHz to 3,4 GHz.....</b>	<b>58</b>
<b>Annex F (normative):</b>	<b>Broadband wireless access services in the band 3,4 GHz to 3,8 GHz .....</b>	<b>59</b>
<b>Annex G (normative):</b>	<b>Radiolocation services in the band 8,5 GHz to 9,0 GHz.....</b>	<b>60</b>
<b>Annex H (informative):</b>	<b>Calculation of peak limit for 3 MHz measurement bandwidth.....</b>	<b>61</b>
<b>Annex I (normative):</b>	<b>ICS Proforma for DAA radio device.....</b>	<b>63</b>
I.1	Identification of the protocol.....	63
I.2	ICS proforma tables.....	63
I.2.1	Avoidance Modes.....	63
<b>Annex J (informative):</b>	<b>Bibliography.....</b>	<b>64</b>
<b>Annex K (informative):</b>	<b>The EN title in the official languages .....</b>	<b>65</b>
History	.....	66

---

## Intellectual Property Rights

IPRs essential or potentially essential to the present document may have been declared to ETSI. The information pertaining to these essential IPRs, if any, is publicly available for **ETSI members and non-members**, and can be found in ETSI SR 000 314: "*Intellectual Property Rights (IPRs); Essential, or potentially Essential, IPRs notified to ETSI in respect of ETSI standards*", which is available from the ETSI Secretariat. Latest updates are available on the ETSI Web server (<http://webapp.etsi.org/IPR/home.asp>).

Pursuant to the ETSI IPR Policy, no investigation, including IPR searches, has been carried out by ETSI. No guarantee can be given as to the existence of other IPRs not referenced in ETSI SR 000 314 (or the updates on the ETSI Web server) which are, or may be, or may become, essential to the present document.

---

## Foreword

This Harmonized European Standard (Telecommunications series) has been produced by ETSI Technical Committee Electromagnetic compatibility and Radio spectrum Matters (ERM), and is now submitted for the Public Enquiry phase of the ETSI standards Two-step Approval Procedure.

The present document has been produced by ETSI in response to a mandate from the European Commission issued under Council Directive 98/34/EC [i.2] (as amended) laying down a procedure for the provision of information in the field of technical standards and regulations.

The present document is intended to become a Harmonized Standard, the reference of which will be published in the Official Journal of the European Communities referencing the Directive 1999/5/EC [i.3] of the European Parliament and of the Council of 9 March 1999 on radio equipment and telecommunications terminal equipment and the mutual recognition of their conformity ("the R&TTE Directive").

The present document is intended to cover the provisions of article 3.2 of Directive 1999/5/EC (R&TTE Directive) [i.3].

The present document does not apply to radio equipment for which a specific Harmonized EN applies as such. Harmonized EN may specify additional EN requirements relevant to the presumption of conformity under article 3.2 of the R&TTE Directive.

Technical specifications relevant to Directive 1999/5/EC [i.3] are given in annex A.

<b>Proposed national transposition dates</b>	
Date of latest announcement of this EN (doa):	3 months after ETSI publication
Date of latest publication of new National Standard or endorsement of this EN (dop/e):	6 months after doa
Date of withdrawal of any conflicting National Standard (dow):	18 months after doa

---

# Introduction

The present document is part of a set of standards developed by ETSI and is designed to fit in a modular structure to cover all radio and telecommunications terminal equipment within the scope of the R&TTE Directive. The modular structure is shown in EG 201 399 [i.1].

## UWB Technologies

The present document provides a generic set of technical requirements covering many different types of UWB technologies used for short range communications. These technologies can be broken down into two groups:

- 1) Impulse based technologies; and
- 2) RF carrier based technologies.

The following clauses give a brief overview of these UWB technologies and their associated modulation techniques.

### Impulse technology

Impulse derived UWB technology consists of a series of impulses created from a dc voltage step whose rise time can be modified to provide the maximum useful number of spectral emission frequencies. This derived impulse can then be suitably modified by the use of filters to locate the resulting waveform within a specific frequency spectrum range. This filter can be a stand alone filter or incorporated into an antenna design to reduce emissions outside the designated frequency spectrum.

Modulation techniques include pulse positioning in time, pulse suppression and other techniques to convey information. The transmitted energy is summed at the receiver to reproduce the transmitted pulse.

This technology is suitable for direct and non-direct line of sight communications, any reflected or time delayed emissions being suppressed by the receiver input circuits.

### RF carrier based technology

RF carrier based UWB technology is based upon classical radio carrier technology suitably modulated by a baseband modulating process. The modulating process must produce a bandwidth in excess of 50 MHz to be defined as UWB.

Different modulating processes are used to transmit the data information to the receiver and can consist of a series of single hopping frequencies or multi-tone carriers.

This technology can be used for both direct and non-direct line of sight communications, any reflected or time delayed emissions being suppressed by the receiver input circuits.

### Test and measurement limitations

The ERA report 2006-0713 [i.9] has shown that there are practical limitations on measurements of RF radiated emissions. The minimum radiated levels that can be practically measured in the lower GHz frequency range by using a radiated measurement setup with a horn antenna and pre-amplifier are typically in the range of about -70 dBm/MHz to -75 dBm/MHz (e.i.r.p) to have sufficient confidence in the measured result (i.e. UWB signal should be at least 6 dB above the noise floor of the spectrum analyser and the measurement is performed under far-field conditions at a one meter distance).

For equipment that have detachable antennas and provide a 50 ohm antenna port, conducted measurements can be made providing suitable antenna calibrations can be provided. In the present document, test suites for conducted measurements are only provided for DAA conformance measurements. All transmitter emissions of the radio device are expected to be measured using the radiated measurement setup.

For integrated antenna equipment, previous ETSI testing standards have allowed equipment modification to provide a 50 ohm test adaptor to be added to provide the necessary test port. However, UWB integral equipment and particularly impulse based technology does not use classical radio techniques and as such is unlikely to have matched 50 ohm antenna port impedances.

The present document therefore recognizes these difficulties and provides a series of test methods suitable for the different UWB technologies.



# 1 Scope

The present document applies to transceivers, transmitters and receivers utilizing Ultra WideBand (UWB) technologies and used for short range communication purposes.

The present document applies to impulse, modified impulse and RF carrier based UWB communication technologies.

The present document applies to fixed (indoor only), mobile or portable applications, e.g.:

- stand-alone radio equipment with or without its own control provisions;
- plug-in radio devices intended for use with, or within, a variety of host systems, e.g. personal computers, hand-held terminals, etc.;
- plug-in radio devices intended for use within combined equipment, e.g. cable modems, set-top boxes, access points, etc.;
- combined equipment or a combination of a plug-in radio device and a specific type of host equipment;
- equipment for use in road and rail vehicles.

NOTE 1: As per the ECC/DEC/(06)04 [i.4] and Decision 2007/131/EC [i.5] and its amendment the UWB transmitter equipment conforming to this standard is not to be installed at a fixed outdoor location, for use in flying models, aircraft and other forms of aviation.

The present document applies to UWB equipment with an output connection used with a dedicated antenna or UWB equipment with an integral antenna.

These radio equipment types are capable of operating in all or part of the frequency bands given in Table 1.

**Table 1: Radiocommunications frequency bands**

Radiocommunications frequency bands	
Transmit	3,1 GHz to 4,8 GHz
Receive	3,1 GHz to 4,8 GHz
Transmit	6,0 GHz to 9 GHz
Receive	6,0 GHz to 9 GHz

NOTE: The UWB radio device can also operate outside of the radiocommunications frequency bands shown in the present table provided that the limits in clause 4.1.2.3, Table 3 are met.

NOTE 2: A list of such ENs is included on the web site <http://www.newapproach.org>.

# 2 References

References are either specific (identified by date of publication and/or edition number or version number) or non-specific.

- For a specific reference, subsequent revisions do not apply.
- Non-specific reference may be made only to a complete document or a part thereof and only in the following cases:
  - if it is accepted that it will be possible to use all future changes of the referenced document for the purposes of the referring document;
  - for informative references.

Referenced documents which are not found to be publicly available in the expected location might be found at <http://docbox.etsi.org/Reference>.

NOTE: While any hyperlinks included in this clause were valid at the time of publication ETSI cannot guarantee their long term validity.

## 2.1 Normative references

The following referenced documents are indispensable for the application of the present document. For dated references, only the edition cited applies. For non-specific references, the latest edition of the referenced document (including any amendments) applies.

- [1] ETSI TR 100 028 (V1.4.1) (all parts): "Electromagnetic compatibility and Radio spectrum Matters (ERM); Uncertainties in the measurement of mobile radio equipment characteristics".
- [2] ANSI C63.5 (2004): "American National Standard for Electromagnetic Compatibility-Radiated Emission Measurements in Electromagnetic Interference (EMI) Control-Calibration of Antennas (9 kHz to 40 GHz)".
- [3] ITU-R Recommendation SM 329-10 (2003): "Unwanted emissions in the spurious domain".
- [4] ETSI TS 102 321 (V1.1.1): "Electromagnetic compatibility and Radio spectrum Matters (ERM); Normalized Site Attenuation (NSA) and validation of a fully lined anechoic chamber up to 40 GHz".
- [5] ETSI TS 102 754 (V1.2.1): "Electromagnetic compatibility and Radio spectrum Matters (ERM); Short Range Devices (SRD); Technical characteristics of Detect-And-Avoid (DAA) mitigation techniques for SRD equipment using Ultra Wideband (UWB) technology".

## 2.2 Informative references

The following referenced documents are not essential to the use of the present document but they assist the user with regard to a particular subject area. For non-specific references, the latest version of the referenced document (including any amendments) applies.

- [i.1] ETSI EG 201 399 (V2.1.1): "Electromagnetic compatibility and Radio spectrum Matters (ERM); A guide to the production of candidate Harmonized Standards for application under the R&TTE Directive".
- [i.2] Directive 1998/34/EC as amended by 1998/48/EC the European Parliament and of the Council of 22 June 1998 laying down a procedure for the provision of information in the field of technical standards and regulations.
- [i.3] Directive 1999/5/EC of the European Parliament and of the Council of 9 March 1999 on radio equipment and telecommunications terminal equipment and the mutual recognition of their conformity (R&TTE Directive).
- [i.4] CEPT ECC/DEC/(06)04 of 24 March 2006 amended 6 July 2007 at Constanza on the harmonized conditions for devices using Ultra-Wideband (UWB) technology in bands below 10.6 GHz.
- [i.5] Decision 2007/131/EC: commission decision of 21 February 2007 on allowing the use of the radio spectrum for equipment using ultra-wideband technology in a harmonised manner in the Community (notified under document number C(2007) 522).
- [i.6] ITU-R Recommendation SM.1754 (2006): "Measurement techniques of ultra-wideband transmissions".
- [i.7] ETSI TR 102 273 (V1.2.1) (all parts): "Electromagnetic compatibility and Radio spectrum Matters (ERM); Improvement of radiated methods of measurement (using test sites) and evaluation of the corresponding measurement uncertainties".
- [i.8] ETSI TR 102 070-2 (V1.1.1): "Electromagnetic compatibility and Radio spectrum Matters (ERM); Guide to the application of harmonized standards to multi-radio and combined radio and non-radio equipment; Part 2: Effective use of the radio frequency spectrum".
- [i.9] ERA Report 2006-0713: "Conducted and radiated measurements for low level UWB emissions".

- [i.10] ECC Report 120 (March 2008): "ECC Report on Technical requirements for UWB DAA (Detect and avoid) devices to ensure the protection of radiolocation in the bands 3.1-3.4 GHz and 8.5-9 GHz and BWA terminals in the band 3.4 - 4.2 GHz".

---

## 3 Definitions, symbols and abbreviations

### 3.1 Definitions

For the purposes of the present document, the following terms and definitions apply:

**avoidance level:** maximum amplitude to which the UWB transmit power is set for the relevant protection zone

**combined equipment:** any combination of non-radio equipment and a plug-in radio device that would not offer full functionality without the radio device

**default avoidance bandwidth:** portion of the victim service bandwidth to be protected if no enhanced service bandwidth identification mechanisms are implemented in the DAA enabled devices

**detect and avoid time:** time duration between a change of the external RF environmental conditions and adaptation of the corresponding UWB operational parameters

**detection probability:** probability that the DAA enabled UWB radio device reacts appropriately to a signal detection threshold crossing within the detect and avoid time

**dedicated antenna:** removable antenna supplied and tested with the radio equipment, designed as an indispensable part of the equipment

**effective radiated power (e.r.p):** product of the power supplied to the antenna and its gain relative to a half-wave dipole in a given direction (RR 1.162)

**equivalent isotropically radiated power (e.i.r.p):** product of the power supplied to the antenna and the antenna gain in a given direction relative to an isotropic antenna (absolute or isotropic gain) (RR 1.161)

**gating:** transmission that is intermittent or of a low duty cycle referring to the use of burst transmissions where a transmitter is switched on and off for selected time intervals

**hopping:** spread spectrum technique whereby individual radio links are continually switched from one subchannel to another

**host:** host equipment is any equipment which has complete user functionality when not connected to the radio equipment part and to which the radio equipment part provides additional functionality and to which connection is necessary for the radio equipment part to offer functionality

**impulse:** pulse whose width is determined by its dc step risetime and whose maximum amplitude is determined by its dc step value

**in operation channel availability check time:** minimum time the UWB radio device spends searching for victim signals during normal operation, Parameter:  $T_{in\ op\ avail}$

**integral antenna:** permanent fixed antenna, which may be built-in, designed as an indispensable part of the equipment

**maximum avoidance power level:** UWB transmit power assuring the equivalent protection of the victim service

**minimum avoidance bandwidth:** portion of the victim service bandwidth requiring protection

**minimum initial channel availability check time:** minimum time the UWB radio device spends searching for victim signals after power on, Parameter:  $T_{avail, Time}$

**narrowband:** See test in clause 5.8.5.

**Non-Interference mode operation (NIM):** operational mode that allows the use of the radio spectrum on a non-interference basis without active mitigation techniques

**plug-in radio device:** radio equipment module intended to be used with or within host, combined or multi-radio equipment, using their control functions and power supply

**pulse:** short transient signal whose time duration is nominally the reciprocal of its -10 dB bandwidth

**rf carrier:** fixed radio frequency prior to modulation

**signal detection threshold:** amplitude of the victim signal which defines the transition between adjacent protection zones, Parameter:  $D_{\text{thresh}}$

NOTE: The threshold level is defined to be the signal level at the receiver front end of the UWB DAA radio device and assuming a 0 dBi receive antenna.

**signal detection threshold set:** set of amplitudes of the victim signal which defines the transition between adjacent protection zones

**stand-alone radio equipment:** equipment that is intended primarily as communications equipment and that is normally used on a stand-alone basis

**victim signal:** signal(s) of the service to be detected and protected by the DAA mitigation technique

**wideband:** emission whose occupied bandwidth is greater than the test equipment measurement bandwidth

## 3.2 Symbols

For the purposes of the present document, the following symbols apply:

$\Omega$	ohm
$\lambda$	wavelength
$D$	detection threshold
dB	decibel
dBi	gain in decibels relative to an isotropic antenna
dBm	gain in decibels relative to one milliwatt
$f$	frequency
$f_H$	highest frequency of the power envelope
$f_L$	lowest frequency of the power envelope
$I$	Isolation in dB
$P$	Power in dBm
$R$	Distance
$T_{\text{avail\_time\_min}}$	Minimum initial channel availability check time
$T_{\text{avoid}}$	Detect and avoid time

NOTE: Actual Detect and Avoid time of a DUT, can be negative.

$T_{\text{avoid\_max}}$	Maximum allowed Detect and avoid time
$T$	time

## 3.3 Abbreviations

For the purposes of the present document, the following abbreviations apply:

AC	Alternating Current
ATT	ATTenuator/ATTenuation
BPSK	Binary Phase Shift Keying
BWA	Broadband Wireless Access
CEPT	European Conference of Postal and Telecommunications Administrations
CON	Conformance test results
CPC	Cognitive Pilot Channels
DAA	Detect And Avoid

dc	direct current
e.i.r.p.	equivalent isotropically radiated power
e.r.p.	effective radiated power
ECC	Electronic Communications Committee
EIRP	Equivalent Isotropically Radiated Power
EUT	Equipment Under Test
FDD	Frequency Division Duplex
FH	Frequency Hopping
FMCW	Frequency Modulated Continuous Wave
FSK	Frequency Shift Keying
HS	Harmonized Standard
ICS	Implementation Conformance Statement
LDC	Low Duty Cycle
LFM	Linear Frequency Modulation
LNA	Low Noise Amplifier
NIM	Non Interference Mode
OFDM	Orthogonal Frequency Division Multiplexing
OFDMA	Orthogonal Frequency Division Multiple Access
PRF	Pulse Repetition Frequency
R&TTE	Radio and Telecommunications Terminal Equipment
RBW	Resolution BandWidth
RF	Radio Frequency
RMS	Root Mean Square
RR	Radio Regulations
Rx	Receiver
SNR	Signal to Noise Ratio
SRD	Short Range Device
TDD	Time Division Duplex
TPC	Transmit Power Control
Tx	Transmitter
UWB	Ultra WideBand
VBW	Video BandWidth
VSWR	Voltage Standing Wave Ratio

---

## 4 Technical requirements specification

### 4.1 Technical requirements

#### 4.1.1 Operating bandwidth

##### 4.1.1.1 Definition

The width of a frequency band such that, below the lower and above the upper frequency limits, the mean powers emitted are each equal to a percentage of 5 % of the total mean power of a given emission.

For the purposes of the present document the measurements are made at the -13 dB points.

##### 4.1.1.2 Test procedure

This test shall be performed using a radiated test procedure (see clause 5.4.4 and annex B).

##### 4.1.1.3 Limit

The operating bandwidth shall be greater than 50 MHz (at -10 dB relative to the maximum spectral power density).

#### 4.1.1.4 Measurement uncertainty

See Table 11.

### 4.1.2 Maximum value of mean power spectral density

#### 4.1.2.1 Definition

The maximum mean power spectral density (specified as e.i.r.p.) of the radio device under test, at a particular frequency, is the average power per unit bandwidth (centred on that frequency) radiated in the direction of the maximum level under the specified conditions of measurement.

#### 4.1.2.2 Test procedure

This test shall be performed using a radiated test procedure (see clause 5.8.2) for the frequencies as shown in Table 2.

This test shall be repeated at the frequencies as shown in Table 3 including the frequency band edges at 1,6 GHz, 2,7 GHz, 3,1 GHz, 3,4 GHz, 3,8 GHz, 4,8 GHz, 6,0 GHz and 8,5 GHz, 9 GHz and 10,6 GHz as shown in Table 3.

#### 4.1.2.3 Limit

The maximum mean power spectral density measured using the above test procedure shall not exceed the limits given in Tables 2 and 3.

**Table 2: Maximum value of mean power spectral density limit**

Frequency (GHz)	Maximum value of mean power spectral density (dBm/MHz)
$3,1 < f \leq 4,8$	$\leq -41,3$ (see notes 1, 2 and 3)
$6 < f \leq 8,5$	$\leq -41,3$ (see note 4)
$8,5 < f \leq 9$	$\leq -41,3$ (see notes 5 and 6)
<p>NOTE 1: When DAA is implemented, equipment shall implement the whole frequency range from 3,1 GHz to 4,8 GHz. Radio devices shall be capable of selecting an operating channel anywhere within the band 3,1 GHz to 4,8 GHz.</p> <p>NOTE 2: LDC or DAA is required (see clause 4.1.6 or 4.1.7). If LDC or DAA is not implemented then the following applies:</p> <ul style="list-style-type: none"> <li>- 3,1 GHz to 3,4 GHz <math>\leq -70</math> dBm/MHz.</li> <li>- 3,4 GHz to 3,8 GHz <math>\leq -80</math> dBm/MHz.</li> <li>- 3,8 GHz to 4,8 GHz <math>\leq -70</math> dBm/MHz.</li> </ul> <p>NOTE 3: In case of radio devices installed in road and rail vehicles, operation is subject to the implementation of LDC or (TPC and DAA). TPC shall have a range of 12 dB with respect to the maximum value of mean power spectral density. If only DAA is implemented then the following applies:</p> <ul style="list-style-type: none"> <li>- 3,1 GHz to 4,8 GHz <math>\leq -53,3</math> dBm/MHz.</li> </ul> <p>NOTE 4: In case of radio devices installed in road and rail vehicles, operation is subject to the implementation of LDC or Transmit Power Control (TPC). TPC shall have a range of 12 dB with respect to the maximum value of mean power spectral density. If TPC or LDC is not implemented then the following applies:</p> <ul style="list-style-type: none"> <li>- 6 GHz to 8,5 GHz <math>\leq -53,3</math> dBm/MHz.</li> </ul> <p>NOTE 5: If DAA is not implemented then the following applies:</p> <ul style="list-style-type: none"> <li>- 8,5 GHz to 9 GHz <math>\leq -65</math> dBm/MHz</li> </ul> <p>NOTE 6: In case of radio devices installed in road and rail vehicles, operation is subject to the implementation of either DAA and LDC or DAA and TPC. TPC shall have a range of 12 dB with respect to the maximum value of mean power spectral density. If only DAA is implemented then the following applies: 8,5 GHz to 9 GHz <math>\leq -53,3</math> dBm/MHz.</p>	

**Table 3: Maximum value of mean power spectral density limit at frequency band edges**

Frequency (GHz)	Maximum value of mean power spectral density (dBm/MHz)
$f \leq 1,6$	-90
$1,6 < f \leq 2,7$	-85
$2,7 < f \leq 3,1$	-70
$3,1 < f \leq 3,4$ (applies to equipment not using DAA, DAA and TPC or LDC)	-70
$3,4 < f \leq 3,8$ (applies for equipment not using DAA, DAA and TPC or LDC)	-80
$3,8 < f \leq 4,8$ (applies for equipment not using DAA, DAA and TPC or LDC)	-70
$4,8 < f \leq 6$	-70
$8,5 < f \leq 9$ (applies for equipment not using DAA, or DAA and TPC)	-65
$9 < f \leq 10,6$	-65
$f > 10,6$	-85

#### 4.1.2.4 Maximum allowable measurement uncertainty

See Table 11.

### 4.1.3 Maximum value of peak power

#### 4.1.3.1 Definition

The peak power specified as e.i.r.p. contained within a 50 MHz bandwidth at the frequency at which the highest mean radiated power occurs, radiated in the direction of the maximum level under the specified conditions of measurement.

#### 4.1.3.2 Test procedure

This test shall be performed using a radiated test procedure (see clause 5.8.3).

#### 4.1.3.3 Limit

The maximum peak power limit measured using the above test procedure shall not exceed the limits given in Table 4.

Table 4: Maximum peak power limit

Frequency (GHz)	Maximum peak power (dBm, measured in 50 MHz)
$3,1 < f \leq 4,8$	$\leq 0$ (see notes 1, 2 and 3)
$6 < f \leq 8,5$	$\leq 0$ (see note 4)
$8,5 < f \leq 9$	$\leq 0$ (see notes 5 and 6)
NOTE 1: When DAA is implemented, equipment shall implement the whole frequency range from 3,1 GHz to 4,8 GHz. Radio devices shall be capable of selecting an operating channel anywhere within the band 3,1 to 4,8 GHz.	
NOTE 2: LDC or DAA is required (see clause 4.1.6 or 4.1.7). If LDC or DAA is not implemented then the following applies: <ul style="list-style-type: none"> <li>- 3,1 GHz to 3,4 GHz <math>\leq -30</math> dBm, measured in 50 MHz,</li> <li>- 3,4 GHz to 3,8 GHz <math>\leq -40</math> dBm, measured in 50 MHz,</li> <li>- 3,8 GHz to 4,8 GHz <math>\leq -30</math> dBm, measured in 50 MHz.</li> </ul>	
NOTE 3: In case of radio devices installed in road and rail vehicles, operation is subject to the implementation of LDC or (TPC and DAA. TPC shall have a range of 12 dB with respect to the maximum value of peak power. If only DAA is implemented then the following applies: <ul style="list-style-type: none"> <li>- 3,1 GHz to 4,8 GHz <math>\leq -12</math> dBm, measured in 50 MHz.</li> </ul>	
NOTE 4: In case of radio devices installed in road and rail vehicles, operation is subject to the implementation of LDC or Transmit Power Control (TPC). TPC shall have a range of 12 dB with respect to the maximum value of peak power. If TPC or LDC is not implemented then the following applies: <ul style="list-style-type: none"> <li>- 6 GHz to 8,5 GHz <math>\leq -12</math> dBm, measured in 50 MHz.</li> </ul>	
NOTE 5: If DAA is not implemented then the following applies: <ul style="list-style-type: none"> <li>- 8,5 GHz to 9 GHz <math>\leq -25</math> dBm, measured in 50 MHz.</li> </ul>	
NOTE 6: In case of radio devices installed in road and rail vehicles, operation is subject to the implementation of DAA and LDC or DAA and TPC. TPC shall have a range of 12 dB with respect to the maximum value of peak power. If only DAA is implemented then the following applies: <ul style="list-style-type: none"> <li>- 8,5 GHz to 9 GHz <math>\leq -12</math> dBm, measured in 50 MHz.</li> </ul>	

The power reading on the spectrum analyser can be directly related to the peak power limit when a spectrum analyser resolution bandwidth of 50 MHz is used for the measurements. If a spectrum analyser resolution bandwidth of X MHz is used instead, the maximum peak power limit shall be scaled down by a factor of  $20 \log(50/X)$ , where X represents the measurement bandwidth used.

EXAMPLE: If the maximum peak power in a particular frequency band is 0 dBm/50 MHz, and a 3 MHz resolution bandwidth is used in case of an impulsive technology, then the measured value shall not exceed -24,4 dBm (see annex D).

For rf carrier based modulation using multi-tone carriers and not having gating techniques implemented, the maximum peak power limit shall be scaled down by a different factor of  $10 \log(50/X)$ , where X represents the measurement bandwidth used.

#### 4.1.3.4 Maximum allowable measurement uncertainty

See Table 11.

### 4.1.4 Transmit Power Control

#### 4.1.4.1 Definition

Transmit Power Control (TPC) is a mechanism to be used to ensure an interference mitigation on the aggregate power from a large number of radio devices. The TPC mechanism shall provide the full range from the highest to the lowest power level of the radio device and is required for UWB radio devices intended to be installed in road or rail vehicles.

#### 4.1.4.2 Test procedure

TPC tests to assess the highest and lowest power spectral density level shall be measured using a radiated test procedure (see clause 5.8.2).



#### 4.1.4.3 Limit

The maximum value of power spectral density when configured to operate at the highest level of the TPC range shall not exceed the levels given in Table 5a.

**Table 5a: Limits for maximum value of power spectral density at the highest level of the TPC range**

Frequency range (MHz)	Power spectral density limit (e.i.r.p.) (dBm/MHz)
3 100 to 4 800 (radio devices are also subject to DAA or LDC implementation)	-41,3
6 000 to 8 500	-41,3
8 500 to 9 000 (radio devices are also subject to DAA implementation)	-41,3

The maximum value of power spectral density when configured to operate at the lowest level of the TPC range shall not exceed the levels given in Table 5b.

**Table 5b: Limits for maximum value of power spectral density at the lowest level of the TPC range**

Frequency range (MHz)	Power spectral density limit (e.i.r.p.) (dBm/MHz)
3 100 to 4 800 (radio devices are also subject to DAA or LDC implementation)	-53,3
6 000 to 8 500	-53,3
8 500 to 9 000 (radio devices are also subject to DAA implementation)	-53,3

#### 4.1.4.4 Maximum allowable measurement uncertainty

See Table 11.

### 4.1.5 Receiver spurious emissions

#### 4.1.5.1 Definition

Receiver spurious emissions are emissions at any frequency when the equipment is in receive mode. Consequently, receiver spurious emission testing applies only when the equipment can work in a receive-only mode.

#### 4.1.5.2 Test procedure

The radiated test procedures as defined in clause 5.8.5 shall be used.

#### 4.1.5.3 Limit

The narrowband spurious emissions of the receiver shall not exceed the values in Tables 6 and 7 in the indicated bands.

**Table 6: Narrowband spurious emission limits for receivers**

Frequency range	Limit
30 MHz to 1 GHz	-57 dBm (e.r.p.)
above 1 GHz to 40 GHz	-47 dBm (e.i.r.p.)

The above limit values apply to narrowband emissions, e.g. as caused by local oscillator leakage. The measurement bandwidth for such emissions may be as small as necessary to get a reliable measurement result.

Wideband spurious emissions shall not exceed the values given in Table 7.

**Table 7: Wideband spurious emission limits for receivers**

Frequency range	Limit
30 MHz to 1 GHz	-47 dBm/MHz (e.r.p.)
above 1 GHz to 40 GHz	-37 dBm/MHz (e.i.r.p.)

#### 4.1.5.4 Maximum allowable measurement uncertainty

See Table 11.

### 4.1.6 Detect-And-Avoid (DAA)

#### 4.1.6.1 Introduction

UWB radio devices can be equipped with Detect and Avoid algorithms in the presence of Radar signals in the range 3,1 GHz to 3,4 GHz and 8,5 GHz to 9 GHz and BWA systems in the range 3,4 GHz to 3,8 GHz.

The preferred test set-up shall be a radiated test set-up. For equipment that have detachable antennas and provide a 50 ohm antenna port, conducted measurements can be made providing suitable antenna calibrations can be provided.

The UWB radio devices under test will be configured as a master-slave pair or equivalent where at least one of the radio devices has a DAA capability. The separation of these radio devices will be such that a good link between the two radio devices can be assured at all times. Only the DAA equipped radio device need be illuminated in the Victim service field. If this is not possible and where both radio devices are DAA enabled, then care should be taken to prevent false triggering.

##### 4.1.6.1.1 Applicable frequency ranges

The required UWB operational frequencies are defined by the victim services. For the purposes of the present document the measurements are made at the -10 dBc points.

The operational frequency bands required are given in Table 8. The UWB system bandwidth as defined by the -10 dBc points shall at least partly include the victim service. Where the frequency span of the UWB radio device is insufficient to cover the victim service's bandwidth, the frequency range shall be split into two bands and tests repeated for the higher and lower frequency ranges.

**Table 8: UWB System bandwidth for test**

Victim Service	Bandwidth	Comments
S-band Radiolocation	3,1 GHz to 3,4 GHz	NIM power level: - -70 dBm/MHz mean - -36 dBm peak in 50 MHz
BWA	3,4 GHz to 3,8GHz	NIM power level: - -80 dBm/MHz mean - -40 dBm in 50 MHz peak
X-Band Radiolocation	8,5 GHz to 9 GHz	NIM power level: - -65 dBm/MHz mean - -25 dBm in 50 MHz peak

##### 4.1.6.1.2 DAA operational modes

To assure repeatability of the tests it will be necessary to ensure that all UWB radio devices under test follow a predefined start up and enter a known status following the start up. The condition at the end of the start up shall be dependent upon the test being undertaken. The suggested status is given in Table 9.

**Table 9: UWB radio device status during test**

Test ID	UWB Status after start-up	Comments
TD_Radar_001 & BWA_006	NIM operation: - LDC - NIM power level	The UWB DAA radio device should be set into a operational state where it intend to operate in a non NIM operation after the <i>Minimum Initial Channel Availability Check Time</i>
TD_Radar_002, 003 and BWA_007, 008	NIM operation: - LDC - NIM power level	The UWB DAA radio device should be set into a operational state where it intend to operate in a non NIM operation after the <i>Minimum Initial Channel Availability Check Time</i>
TD_Radar_005 and TD_BWA_009	Transmitting/Receiving data at Payload levels identified in the relevant test section at max permitted mean power level	Payload shall be 50 % For a two zone system, the max mean power level will normally be -41,3 dBm/MHz

#### 4.1.6.2 Test procedure

See clauses 5.8.7 and 5.8.8.

#### 4.1.6.3 Limit

The DAA limits are expressed in normative annexes E to G.

#### 4.1.6.4 Maximum allowable measurement uncertainty

See Table 11.

### 4.1.7 Low Duty Cycle (LDC)

#### 4.1.7.1 Definitions

Tx on is the duration of a transmission burst and Tx off is the time interval between two consecutive transmission bursts.

#### 4.1.7.2 Test procedure

The manufacturer shall provide sufficient information for determining compliance with the limits given in Table 10.

#### 4.1.7.3 Limits

**Table 10: LDC limits**

LDC parameter	Value
Maximum Tx on	≤ 5 ms
Minimum mean Tx off	≥ 38 ms (mean value averaged over one (1) second)
Accumulated minimum Tx off ( $\Sigma$ Tx off)	≥ 950 ms in one (1) second
Maximum accumulated transmission time ( $\Sigma$ Tx on)	18 s in one (1) hour

UWB radio devices having LDC and DAA implemented and operating in all or part of the frequency band from 3,1 GHz to 4,8 GHz may switch on the LDC parameter set to avoid interference to BWA services and radiolocation services as shown in Table E.1.

### 4.1.8 Equivalent mitigation techniques

Other mitigation techniques and mitigation factors can be taken into account for the calculation of the maximum allowed TX power of an UWB radio device as long as the reached mitigation factors are equivalent or higher than the mitigation factors reached using the presented techniques which have been accepted by the CEPT/ECC and are documented in the CEPT report 120. Examples for additional mitigation factors could be the deployment of the radio device in a restricted indoor area with higher wall attenuation, shielding or the deployment and installation of the UWB system in a controlled manner where the use of BWA terminals is not allowed or coordinated with the deployment of the UWB system. The additional mitigation factors need to be weighted against the specific services to be protected and a similar approach has to be taken like in CEPT report 120.

The manufacturer shall provide sufficient information for determining compliance with the transmission emission limits in clauses 4.1.2 and 4.1.3 when using equivalent mitigation techniques.

**NOTE:** Regulations in the EC decision 2007/131/EC [i.5] and its amendment allow for other equivalent mitigation techniques to be used across all frequency bands, where these offer at least equivalent protection to that provided by the limits in the Decision.

**EXAMPLE:** LDC is presumed that this technique will provide an equivalent level of protection in the 3,1 GHz to 4,8 GHz frequency band compared with DAA. This means that, in the frequency band it will be possible to use UWB equipment inside a railway or automotive vehicle where either the TPC or the LDC mitigation technique is applied.

---

## 5 Essential radio test suites

### 5.1 Product information

The following product information shall be provided by the manufacturer:

- the type of UWB technology implemented in the equipment (e.g. carrier-based, impulse, modified impulsed, etc.);
- the type of modulation schemes available (e.g. OFDM modulation, pulsed modulation or any other type of modulation etc.);
- for FMCW, FH, FSK or similar carrier based modulation schemes, it is important to describe the modulation parameters in order to ensure that the right settings of the measuring receiver are used. To ensure coincidence, the measurement should also be repeated using different analyzer sweep times. Important parameters are the modulation period, deviation or dwell times within a modulation period, rate of modulation (Hz/s);
- the operating frequency range(s) of the equipment (see clause 4.1.1);
- the type of the equipment (e.g. stand-alone equipment, plug-in radio device, combined equipment etc), (see also clause 5.5);
- the intended combination(s) of the radio equipment power settings and one or more antenna assemblies and their corresponding e.i.r.p. levels (see also clause 5.4);
- the nominal power supply voltages of the stand-alone radio equipment or the nominal power supply voltages of the host equipment or combined equipment in case of plug-in radio devices;
- the test modulation to be used for testing (see also clause 5.2);
- the implementation of features such as gating or hopping;
- the implementation of any mitigation or equivalent mitigation techniques (see also clause 4.1.8);
- in case of conducted DAA measurements, the antenna impedance over the operating frequency range as well as maximum antenna gain characteristics (frequency response) over the operating frequency range(s).

## 5.2 Requirements for the test modulation

The test modulation used should be representative of normal use of the equipment and which results in the highest mean transmit power spectral density.

The highest mean transmit power spectral density is also grossly affected by frame/packet length, inter-packet gaps, normal and burst modes. The manufacturer shall declare this information and that the settings were used that are considered to lead to the highest mean transmit power spectral density.

Where the equipment is not capable of continuous RF transmission, the test modulation shall be such that:

- the generated RF signal is the same frame structure with random data for each transmission;
- transmissions occur regularly in time;
- sequences of transmissions can be repeated accurately.

The same test modulation shall be used for all measurements on the same equipment. For transmitters that have multi-modulation schemes incorporated, the manufacturer shall declare the modulation scheme to be used for the tests.

Implemented transmitter timeout functionality shall be disabled for the sequence of the test suite.

Where radio devices are equipped with LDC, the LDC operation will be disabled for the duration of the test.

The manufacturer shall provide the means to operate the transmitter during the tests.

## 5.3 Test conditions, power supply and ambient temperatures

### 5.3.1 Test conditions

Testing shall be performed under normal test conditions.

The test conditions and procedures shall be performed as specified in the following clauses.

### 5.3.2 Power sources

#### 5.3.2.1 Power sources for stand-alone equipment

During testing, the power source of the equipment shall be replaced by a test power source capable of producing normal test voltages as specified in clause 5.3.3.2. The internal impedance of the test power source shall be low enough for its effect on the test results to be negligible. For the purpose of tests, the voltage of the power source shall be measured at the input terminals of the equipment.

For battery operated equipment the battery may be removed and the test power source shall be applied as close to the battery terminals as practicable.

During tests the power source voltages shall be maintained within a tolerance of  $\pm 1$  % relative to the voltage at the beginning of each test. The value of this tolerance is critical to power measurements; using a smaller tolerance will provide better measurement uncertainty values.

#### 5.3.2.2 Power sources for plug-in radio devices

The power source for testing plug-in radio devices shall be provided by a test fixture or host equipment.

Where the host equipment and/or the plug-in radio device is battery powered, the battery may be removed and the test power source applied as close to the battery terminals as practicable.

### 5.3.3 Normal test conditions

#### 5.3.3.1 Normal temperature and humidity

The normal temperature and humidity conditions for tests shall be any convenient combination of temperature and humidity within the following ranges:

- temperature: +15 °C to +35 °C;
- relative humidity: 20 % to 75 %.

When it is impracticable to carry out the tests under these conditions, a note to this effect, stating the ambient temperature and relative humidity during the tests, shall be recorded.

The actual values during the tests shall be recorded.

#### 5.3.3.2 Normal power source

##### 5.3.3.2.1 Mains voltage

The normal test voltage for equipment to be connected to the mains shall be the nominal mains voltage. For the purpose of the present document, the nominal voltage shall be the voltage(s) for which the equipment was designed.

The frequency of the test power source corresponding to the AC mains shall be between 49 Hz and 51 Hz.

##### 5.3.3.2.2 Lead-acid battery power sources used on vehicles

When radio equipment is intended for operation from the usual, alternator fed lead-acid battery power source used on vehicles, then the normal test voltage shall be 1,1 times the nominal voltage of the battery (6 V, 12 V, etc.).

##### 5.3.3.2.3 Other power sources

For operation from other power sources or types of battery (primary or secondary), the nominal test voltage shall be as stated by the equipment manufacturer. This shall be recorded.

## 5.4 Choice of equipment for test suites

### 5.4.1 Choice of model

The tests shall be carried out on one or more production models or equivalent preliminary models, as appropriate. If testing is performed on (a) preliminary model(s), then the corresponding production models shall be identical to the tested models in all respects relevant for the purposes of the present document.

If an equipment has several optional features that are considered to affect directly the RF parameters then tests need only be performed on the equipment configured with the considered worst case combination of features as declared by the manufacturer.

### 5.4.2 Presentation

Stand-alone equipment shall be tested complete with any ancillary equipment.

Plug-in radio devices may be tested together with a suitable test fixture and/or typical host equipment (see clause 5.5).

### 5.4.3 Operating bandwidth

Where equipment has more than one operating bandwidth, a minimum of two operating bandwidths shall be chosen such that the lower and higher limits of the operating range(s) of the equipment are covered (see clause 4.1.2.3). All operating bandwidths of the equipment shall be declared by the equipment manufacturer.

## 5.4.4 Test sites and general arrangements for radiated measurements

The test site, test antenna and substitution antenna used for radiated measurements shall be as described in clause A.1.

For guidance on use of radiation test sites, coupling of signals and standard test positions used for radiated measurements, see clauses B.2 to B.4.

Detailed descriptions of radiated measurement arrangements for UWB radio devices can be found in ITU-R Recommendation SM.1754 [i.6].

All reasonable efforts should be made to clearly demonstrate that emissions from the UWB transmitter do not exceed the specified levels, with the transmitter in the far field. To the extent practicable, the radio device under test shall be measured at the distance specified in clause B.2.4 and with the specified measurement bandwidths. However, in order to obtain an adequate signal-to-noise ratio in the measurement system, radiated measurements may have to be made at distances less than those specified in clause B.2.4 and/or with reduced measurement bandwidths. The revised measurement configuration should be stated on the test report, together with an explanation of why the signal levels involved necessitated measurement at the distance employed or with the measurement bandwidth used in order to be accurately detected by the measurement equipment and calculations demonstrating compliance.

Where it is not practical to further reduce the measurement bandwidth (either because of limitations of commonly-available test equipment or difficulties in converting readings taken using one measurement bandwidth to those used by the limits in Tables 2 to 4, and the required measurement distance would be so short that the radio device would not clearly be within the far field, the test report shall state this fact, the measurement distance and bandwidth used, the near field/far field distance for the measurement setup (see clause B.2.4), the measured radio device emissions, the achievable measurement noise floor and the frequency range(s) involved.

## 5.5 Testing of host connected equipment and plug-in radio devices

For combined equipment and for radio parts for which connection to or integration with host equipment is required to offer functionality to the radio, different alternative test approaches are permitted. Where more than one such combination is intended, testing shall not be repeated for combinations of the radio part and various host equipment where the latter are substantially similar.

Where more than one such combination is intended and the combinations are substantially dissimilar, one combination shall be tested against all requirements of the present document and all other combinations shall be tested separately for radiated spurious emissions only.

### 5.5.1 The use of a host or test fixture for testing plug-In radio devices

Where the radio part is a plug-in radio device which is intended to be used within a variety of combinations, a suitable test configuration consisting of either a test fixture or a typical host equipment shall be used. This shall be representative for the range of combinations in which the radio device may be used. The test fixture shall allow the radio equipment part to be powered and stimulated as if connected to or inserted into the host or combined equipment. Measurements shall be made to all requirements of the present document.

NOTE: For further information on this topic, see TR 102 070-2 [i.8].

### 5.5.2 Testing of combinations

#### 5.5.2.1 Alternative A: General approach for combinations

Combined equipment or a combination of a plug-in radio device and a specific type of host equipment may be used for testing according to the full requirements of the present document.

#### 5.5.2.2 Alternative B: For host equipment with a plug-in radio device

A combination of a plug-in radio device and a specific type of host equipment may be used for testing according to the full requirements of the present document.

For radiated emission tests the most appropriate harmonized EMC standard shall be applied to the host equipment. The plug-in radio device shall meet the radiated emissions requirements as described in clauses 4.1.5.

### 5.5.2.3 Alternative C: For combined equipment with a plug-in radio device

Combined equipment may be used for testing according to the full requirements of the present document.

For radiated emissions the requirements of the most appropriate harmonized EMC standard shall be applied to the non-radio equipment. The plug-in radio device shall meet the radiated emissions requirements as described in clauses 4.1.5. In the case where the plug-in radio device is totally integrated and cannot operate independently, radiated emissions for the combination shall be tested using the most appropriate harmonized standard with the radio part in receive and/or standby mode. If the frequency range is less than the one defined in the present document, additional measurements shall be performed to cover the remaining parts of the frequency range. With the radio in transmit mode, the radiated emissions requirements of the present document shall be applied.

## 5.6 Interpretation of the measurement results

The interpretation of the results for the measurements described in the present document shall be as follows:

- 1) the measured value related to the corresponding limit shall be used to decide whether an equipment meets the requirements of the present document;
- 2) the measurement uncertainty value for the measurement of each parameter shall be recorded;
- 3) the recorded value of the measurement uncertainty shall be wherever possible, for each measurement, equal to or lower than the figures in Table 11, and the interpretation procedure specified in clause 5.6.1 shall be used.

For the test methods, according to the present document, the measurement uncertainty figures shall be calculated in accordance with the guidance provided in TR 100 028 [1] and shall correspond to an expansion factor (coverage factor)  $k = 1,96$  or  $k = 2$  (which provide confidence levels of respectively 95 % and 95,45 % in the case where the distributions characterizing the actual measurement uncertainties are normal (Gaussian)).

Table 11 is based on such expansion factors.

**Table 11: Maximum measurement uncertainty**

Parameter	Uncertainty
Radio Frequency	$\pm 1 \times 10^{-5}$
all emissions, radiated	$\pm 6$ dB (see note)
temperature	$\pm 1$ °C
Humidity	$\pm 5$ %
DC and low frequency voltages	$\pm 3$ %
NOTE: For radiated emissions measurements below 2,7 GHz and above 10,6 GHz it may not be possible to reduce measurement uncertainty to the levels specified in Table 11 (due to the very low signal level limits and the consequent requirement for high levels of amplification across wide bandwidths). In these cases alone it is acceptable to employ the alternative interpretation procedure specified in clause 5.6.2.	

### 5.6.1 Measurement uncertainty is equal to or less than maximum acceptable uncertainty

The interpretation of the results when comparing measurement values with specification limits shall be as follows:

- a) When the measured value does not exceed the limit value the equipment under test meets the requirements of the present document.
- b) When the measured value exceeds the limit value the equipment under test does not meet the requirements of the present document.



- c) The measurement uncertainty calculated by the test technician carrying out the measurement shall be recorded in the test report.
- d) The measurement uncertainty calculated by the test technician may be a maximum value for a range of values of measurement, or may be the measurement uncertainty for the specific measurement undertaken. The method used shall be recorded in the test report.

## 5.6.2 Measurement uncertainty is greater than maximum acceptable uncertainty

The interpretation of the results when comparing measurement values with specification limits should be as follows:

- a) When the measured value plus the difference between the maximum acceptable measurement uncertainty and the measurement uncertainty calculated by the test technician does not exceed the limit value the equipment under test meets the requirements of the present document.
- b) When the measured value plus the difference between the maximum acceptable measurement uncertainty and the measurement uncertainty calculated by the test technician exceeds the limit value the equipment under test does not meet the requirements of the present document.
- c) The measurement uncertainty calculated by the test technician carrying out the measurement shall be recorded in the test report.
- d) The measurement uncertainty calculated by the test technician may be a maximum value for a range of values of measurement, or may be the measurement uncertainty for the specific measurement undertaken. The method used shall be recorded in the test report.

## 5.7 Other emissions

UWB transmitters emit very low power radio signals, comparable with the power of spurious emissions from digital and analogue circuitry. If it can be clearly demonstrated that an emission from the ultra-wideband radio device is not the ultra-wideband emission identified in clause 4.1.1 (e.g. by disabling the radio device's UWB transmitter) or it can clearly be demonstrated that it is impossible to differentiate between other emissions and the UWB transmitter emissions, that emission or aggregated emissions shall be considered against the receiver spurious emissions limits (see clause 4.1.5.3).

## 5.8 Test procedures for essential radio test suites

### 5.8.1 General

This clause describes methods of measurement for the following transmitter and receiver parameters:

- the maximum mean power spectral density (e.i.r.p.);
- the maximum peak power (e.i.r.p.);
- the operating bandwidth(s); and
- the receiver spurious emissions.

The following methods of measurement shall apply to the testing of stand-alone units and to the equipment configurations identified in clause 5.5.

### 5.8.2 Maximum mean power spectral density

See clause 5.3 for the test conditions.

The maximum mean power spectral density shall be determined and recorded.

The following shall be applied to the combination(s) of the radio device and its intended antenna(s). In the case that the RF power level is user adjustable, all measurements shall be made with the highest power level available to the user for that combination.

Radiated measurements shall be made using one of the techniques presented in clause B.4.

Measurements shall be carried out over the frequency ranges as shown in clause 4.1.2.3, Tables 2 and 3.

When measuring maximum mean power spectral density from the radio device under test, the spectrum analyser or equivalent shall be configured as follows unless otherwise stated:

Resolution bandwidth: 1 MHz

NOTE 1: To the extent practicable, the radio device under test is measured using a spectrum analyser configured using the setting described above. However, in order to obtain an adequate signal-to-noise ratio in the measurement system, radiated measurements may have to be made using narrower resolution bandwidths where it is practical. In these cases, the revised measurement configuration should be stated in the test report, together with calculations which permit the measurements taken to be compared with the appropriate limits and an explanation of why the signal levels involved necessitated measurement using the resolution bandwidth employed in order to be accurately determined by the measurement equipment.

Video bandwidth: Not less than the resolution bandwidth.

Detector mode: RMS

NOTE 2: RMS average measurements can be accomplished directly using a spectrum analyser which incorporates an RMS detector. Alternatively, a true RMS level can be measured using a spectrum analyser that does not incorporate an RMS detector (see ITU-R Recommendation SM.1754 [i.6] for details).

Average time (per point on spectrum analyser scan): 1 ms or less.

Frequency Span: Equal to or less than the number of displayed samples multiplied by the resolution bandwidth. The measurement results shall be determined and recorded over the frequency ranges as shown in clause 4.1, Tables 2 and 3.

The measurements shall be repeated at the frequency band edges at 1,6 GHz, 2,7 GHz, 3,1 GHz, 3,4 GHz, 3,8 GHz, 4,8 GHz, 6,0 GHz and 8,5 GHz, 9 GHz and 10,6 GHz. The measurements at the frequency band edges shall be performed at the frequency offsets as shown in Table 12.

**Table 12: Frequency offsets for band edge measurements**

Band edge frequency (GHz)	Frequency with frequency offset applied
1,6	1,6 GHz - 20 MHz
2,7	2,7 GHz - 20 MHz
3,1	3,1 GHz - 20 MHz
3,4	3,4 GHz - 20 MHz
3,8	3,8 GHz - 20 MHz
4,8	4,8 GHz + 20 MHz
6	6 GHz - 20 MHz
8,5	8,5 GHz + 20 MHz
9	9 GHz + 20 MHz
10,6	10,6 GHz + 20 MHz

This frequency offset that is shown in Table 12 is necessary since measurements at the exact frequency edges with a spectrum analyser may integrate energy from both sides of the respective band edge frequency. This is caused by the filter bandwidth of the test equipment.

The measurements shall be repeated for radio devices with TPC implemented within the UWB radio device configured at the lowest power spectral density level.

### 5.8.3 Maximum peak power

See clause 5.3 for the test conditions.

For all UWB modulations the maximum peak power (e.i.r.p.) shall be measured at the frequency of the maximum mean power spectral density as recorded under clause 5.8.2.

Radiated measurements shall be made using one of the techniques presented in clause B.4.

When measuring maximum peak power from the radio device under test, the spectrum analyser used should be configured as follows:

- Frequency: The measurement shall be centred on the frequency at which the maximum mean power spectral density occurs.
- Resolution bandwidth: Equal to or greater than 3 MHz but not greater than 50 MHz for impulsive technology or equal or greater than 10 MHz but not greater than 50 MHz for RF carrier based technology.

NOTE 1: For peak power measurements, the best signal to noise ratio is usually obtained with the widest available resolution bandwidth. However, at the time of writing the present document, there is no knowledge of a measurement receiver being capable of measuring impulsive peak powers with a 50 MHz RBW. Current upper RBW limits for impulsive emissions are in the order of 20 MHz to 25 MHz.

- Video bandwidth: Not less than the resolution bandwidth.
- Detector mode: Peak.
- Display mode: Max. Hold.
- Measurements shall be continued with the transmitter emitting the normal test signal (see clause 5.2) until the displayed trace no longer changes.

NOTE 2: To the extent practicable, the radio device under test is measured using a spectrum analyser configured using the settings described above. However, in order to obtain an adequate signal-to-noise ratio in the measurement system, radiated measurements may have to be made using narrower resolution bandwidths. In these cases, the revised measurement configuration should be stated in the test report, together with calculations which permit the measurements taken to be compared with the appropriate limits and an explanation of why the signal levels involved necessitated measurement using the resolution bandwidth employed in order to be accurately determined by the measurement equipment.

### 5.8.4 Operating bandwidth

Using the following measurement procedure the frequency range (see clause 4.1.2) of the equipment shall be measured and recorded.

During these measurements the test modulation as specified in clause 5.2 shall be used.

The measurement procedure shall be as follows:

- place the spectrum analyser in video averaging mode and max hold mode with a minimum of 50 sweeps selected and activate the transmitter with modulation applied;
- find the lowest frequency below the operating bandwidth at which spectral power density decreases to the level given in clause 4.1.1. This frequency shall be recorded;
- find the highest frequency at which the spectral power density decreases to the level given in clause 4.1.1. This frequency shall be recorded;
- the difference between the lowest frequency and highest frequency measured is the frequency range which shall be recorded.

This measurement shall be repeated for each operating bandwidth as declared by the manufacturer.

The results obtained shall be compared to the limit in clause 4.1.1.3.

## 5.8.5 Receiver spurious emissions

See clause 5.3 for the test conditions.

The level of spurious emissions radiated by cabinet and antenna shall be measured.

The following method of measurement shall apply:

- Above 1 GHz a full anechoic test site as described in clause B.1.1 is preferred for measurement. The spurious emissions as defined in clause 4.1.5.1 shall be measured and recorded.
- Where an anechoic chamber is not available, the test site described in clause B.1.2 may be used with suitable anechoic material placed on the floor of the chamber.
- Below 1 GHz the method and site characteristics described in ITU recommendation SM 329-10 [3] shall be used (see clause B.1.2). The spurious emissions as defined in clause 4.1.5.1 shall be measured and recorded.

The measurement procedure shall be as follows:

- With the equipment in the receive mode, the applicable spectrum shall be searched for emissions that exceed the limit values given in clause 4.1.5.3 or that come to within 6 dB below the limit values given in clause 4.1.5.3. Each occurrence shall be recorded.

Measurements shall be carried out over the frequency range from 30 MHz to 40 GHz.

The measurements shall be performed only under the following conditions:

- The equipment shall be tested in the standby/ receive mode among frequencies as defined in clauses 5.8.4.

Where these measurements are made with a spectrum analyser, the following settings shall be used for narrowband emissions:

- resolution BW: 100 kHz;
- video BW: 300 kHz;
- detector mode: positive peak;
- averaging: off;
- span: 100 MHz;
- amplitude: adjust for middle of the instrument's range;
- sweep time: 1 s.

For measuring emissions that exceed the level of 6 dB below the applicable limit, the resolution bandwidth shall be switched to 30 kHz and the span shall be adjusted accordingly. If the level does not change by more than 2 dB, it is a narrowband emission; the observed value shall be recorded. If the level changes by more than 2 dB, the emission is a wideband emission and its level shall be measured and recorded.

The results obtained shall be compared to the limits in clause 4.1.5.3 in order to prove compliance with the requirement.

## 5.8.6 Low Duty Cycle

The performance of the implementation shall be declared by the manufacturer. Sufficient information about the performed LDC tests shall be provided.

## 5.8.7 Test Procedure for the radiolocation systems DAA test

### 5.8.7.1 Introduction

In the present clause the test procedure for the radiolocation DAA test is depicted. The UWB DAA radio device under test shall be verified under normal operational conditions.

The DAA test is split into two main test conditions:

- start-up test with and without radiolocation test signal; and
- in-operation test.

The start-up test verifies the operation of the UWB DAA radio device during the initial start-up when the DAA UWB radio device intends to operate directly in a non NIM. Thus the UWB DAA radio device need to be set in an operational condition in which this is guaranteed. The test verifies that the UWB DAA radio device respects the defined *Minimum Initial Channel availability Check Time*.

The in-operation test is intended to verify the dynamic behaviour of the UWB DAA radio device under test. During this test the UWB DAA radio device under test shall operate in a normal dynamic operational mode. The manufacturer has to declare this normal operational mode taking into account the zone model.

The radiated test configuration is shown in Figure 1a and the conducted test configuration is shown in Figure 1b.

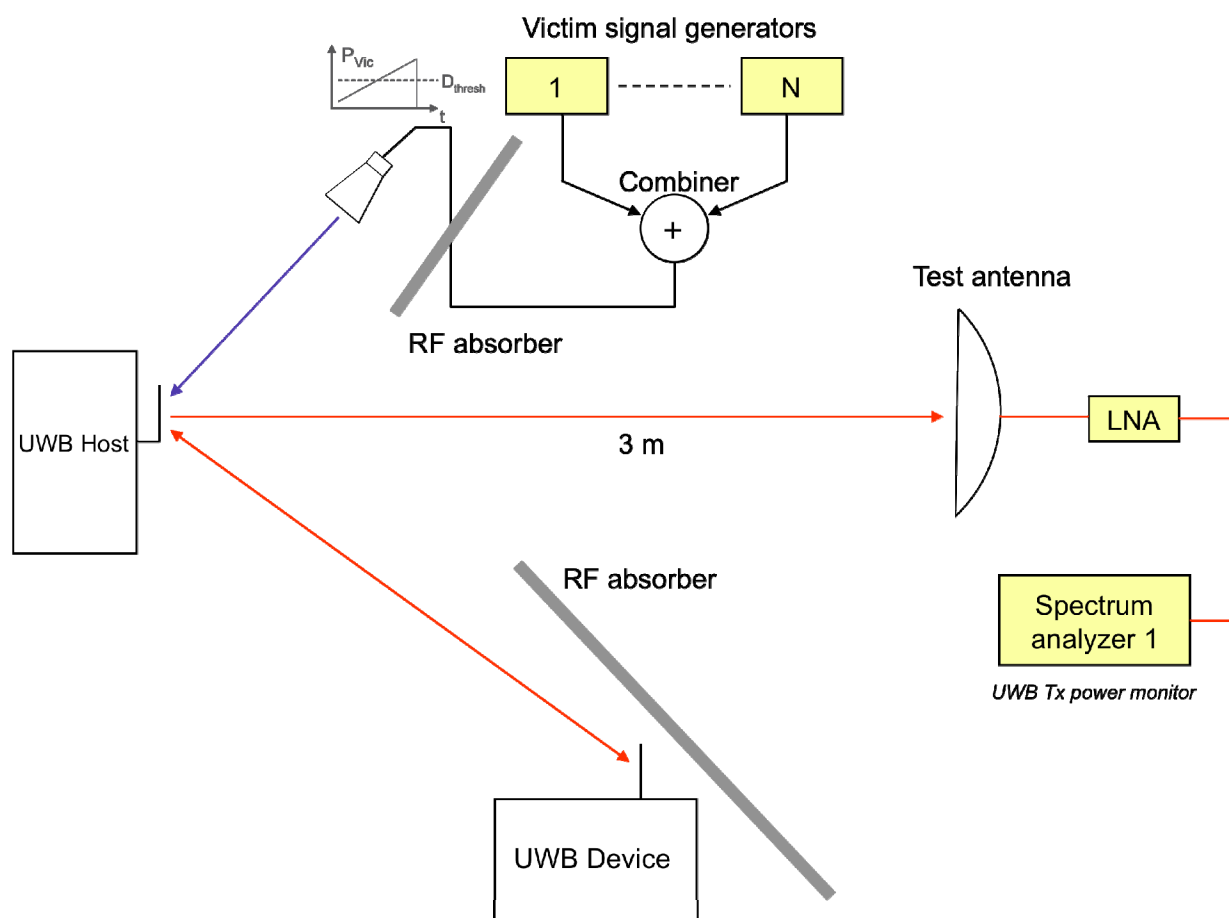
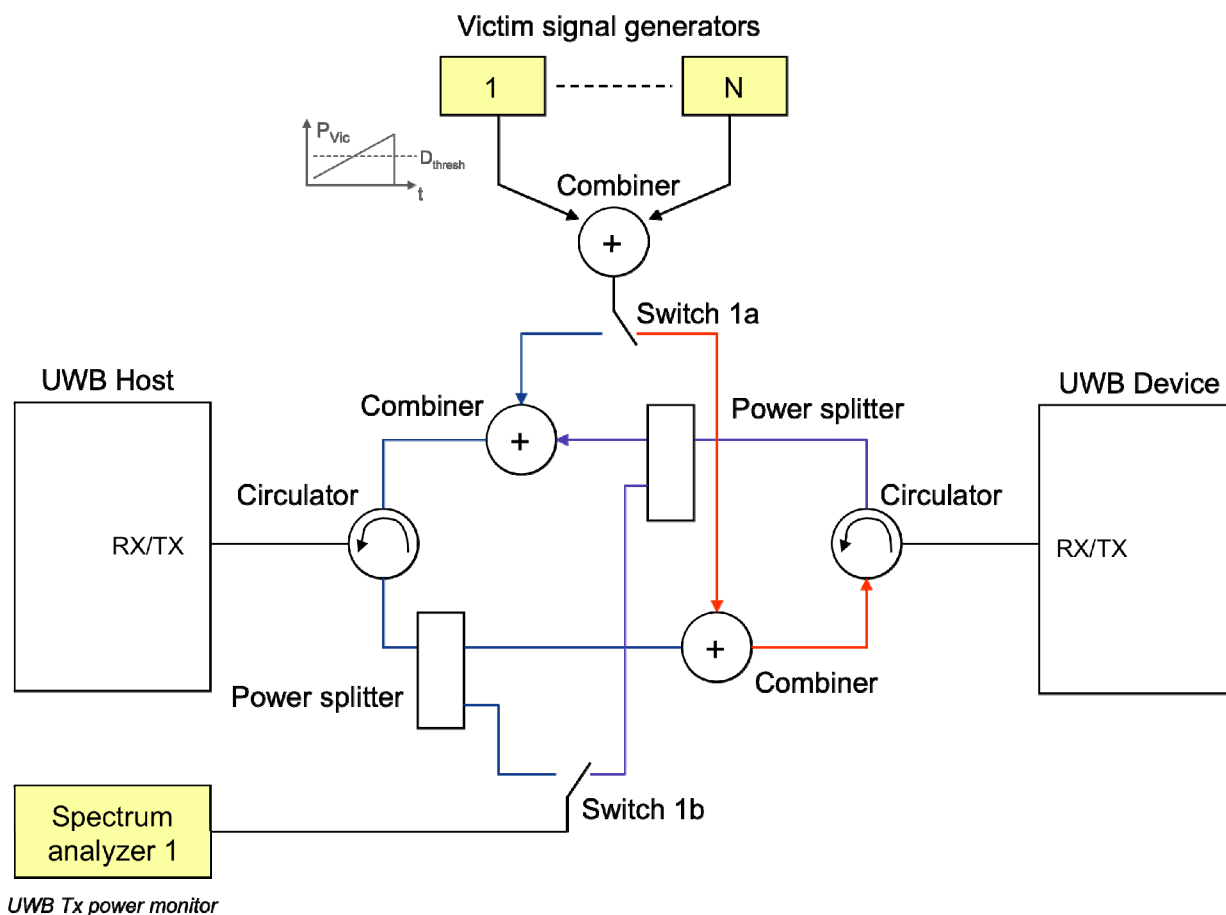

Figure 1a: Example for a test configuration for the radiated DAA test setup



**Figure 1b: Proposal for a test configuration for a conducted DAA test setup**

For equipment that have detachable antennas and provide a 50 ohm antenna port, conducted measurements can be made providing suitable antenna calibrations can be provided. In the present document, test suites for conducted measurements are only provided for DAA conformance measurements. All transmitter emissions of the radio device are expected to be measured using the radiated measurement setup.

**NOTE:** The UWB companion device should be about 2 meters away which is equivalent to about 50 dB attenuation in 3,1GHz to 4,8 GHz and about 56 dB in 8,5 GHz to 9,0 GHz between the EUT and companion devices in the conducted set-up.

### 5.8.7.2 Start-up test

The clauses below define the procedure to verify the *Minimum Initial Channel Availability Check* by ensuring that the UWB DAA radio device is capable of detecting radar pulses at the beginning and at the end of the *Minimum Channel Availability Check Time*. Furthermore, one initial test shall guarantee that the UWB radio device doesn't switch into a NIM operation before the end of the *Minimum Initial Channel Availability Check time*.  $T_{avail\_time\_min}$ .

#### 5.8.7.2.1 Test without a radiolocation test signal during the *Minimum Initial Channel Availability Check Time*, $T_{avail\_time\_min}$

##### Summary:

Verify the UWB DAA radio device will not start transmitting in a non NIM operation before the end of the *Minimum Initial Channel Availability Check Time* when no radiolocation test signal is present. This is illustrated in Figure 2.

**Test description identifier:** TD\_Radar\_001.

**Requirement Reference:** See Table 9.

**Pre-test Condition:**

- UWB radio device supporting DAA
- UWB radio device switched off

**Test Sequence:**

- The UWB DAA radio device will be switched off. No signal generator is connected to the test setup or the signal generator is switched off.
- The UWB DAA radio device is powered on at  $T_0$ .  $T_1$  denotes the instant when the UWB DAA radio device has completed its power-up sequence ( $T_{power\_up}$ ), enters into the operational mode defined in Table 9 and is ready to start the radar detection.

**CON-1:** The UWB DAA radio device shall not switch into a mode other than a NIM before the end of  $T_1 + T_{avail\_time\_min}$  after switch on of the radio device, where the NIM operation is either the LDC mode or the power level defined in annex A for the relevant victim band.

NOTE: Additional verification may be needed to define  $T_1$  in case it is not exactly known or indicated by the UWB DAA radio device.

**CON-2:** A timing trace or description of the observed timing and behaviour of the UWB DAA radio device shall be recorded.

- Repeat b) for 5 times in a row.

**CON-3:** CON-1 and CON-2 shall be fulfilled in all 5 tests. If one failure occurs go to d). For more than one failure the test has not been passed.

- Repeat b) for 10 times in a row.

**CON-4:** CON-1 and CON-2 shall be fulfilled in all 10 tests.

- End of test.

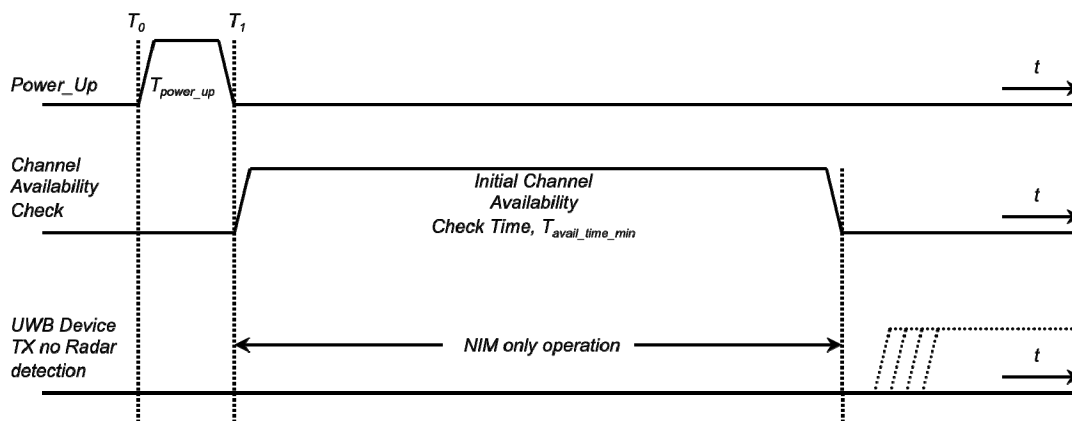

**Figure 2: Example of timing for radiolocation testing of the Minimum Initial Channel Availability Check Time  $T_{avail\_time}$ , UWB DAA device intent to operate in a non NIM mode**

#### 5.8.7.2.2 Tests with a radiolocation test signal at the beginning of the *Minimum Initial Channel Availability Check Time*, $T_{avail\_time\_min}$

**Summary:**

Verify the radar detection and avoidance capability for the selected UWB operational frequency when a radar burst occurs at the beginning of the *Minimum Initial Channel Availability Check Time*. This is illustrated in Figure 3.

**Test description identifier:** TD\_Radar\_002

**Requirement Reference:** See Table 9

**Pre-test Condition:**

- UWB radio device supporting DAA
- UWB radio device switched off

**Test Sequence:**

- a) The UWB DAA radio device will be switched off. The signal generator used to generate the test patterns in Table 13 will be connected to an antenna of suitable characteristics to permit the UWB DAA radio device to be illuminated with a field equal to the threshold detection limit or connected to the corresponding connectors in the case of a conducted measurement setup.
- b) The UWB DAA radio device is powered on at  $T_0$ .  $T_1$  denotes the instant when the UWB DAA radio device has completed its power-up sequence ( $T_{\text{power\_up}}$ ), enters into the operational mode defined in Table 9 and is ready to start the radar detection.
- c) A radar burst is generated in the relevant radiolocation frequency band using the radar test frequency and radar test signal #1 defined in Table 13 at a level of 10 dB above the level defined in annexes E and G and at exactly the threshold levels as defined in annexes E and G. This single-burst radar test signal shall commence within 2 seconds after time  $T_1$ .

**CON-1:** The *Minimum initial Channel Availability Check* is expected to commence at  $T_1$  and is expected to end no sooner than  $T_1 + T_{\text{avail\_time\_min}}$  unless a radiolocation signal is detected sooner.

NOTE: Additional verification may be needed to define  $T_1$  in case it is not exactly known or indicated by the UWB DAA radio device.

**CON-2:** It shall be recorded if the radiolocation test signal was detected. This can be done by verifying that the UWB DAA radio device stays in a NIM operation in the relevant operational band using the *default avoidance bandwidth* of the regarded radiolocation service beyond  $T_1 + T_{\text{avail\_time\_min}}$ .

- d) Repeat a) to c) for 5 times in a row.

**CON-3:** CON-1 and CON-2 shall be fulfilled in all 5 tests. If CON-3 is fulfilled go to f). If one failure occurs go to e). For more than one failure the test has not been passed.

- e) Repeat a) to c) for 10 times in a row.

**CON-4:** CON-1 and CON-2 shall be fulfilled in all 10 tests.

- f) Repeat b) to e) for each of the relevant radar test signals for the UWB operational frequency range as defined in Table 13 at a level of 10 dB above the defined threshold level as defined in annex E and G and at exactly the threshold levels as defined in annexes E and G.

**CON-3:** A timing trace or description of the observed timing and behaviour of the UWB DAA radio device shall be recorded.

- g) Repeat c) to f) for each of the identified radar frequencies.



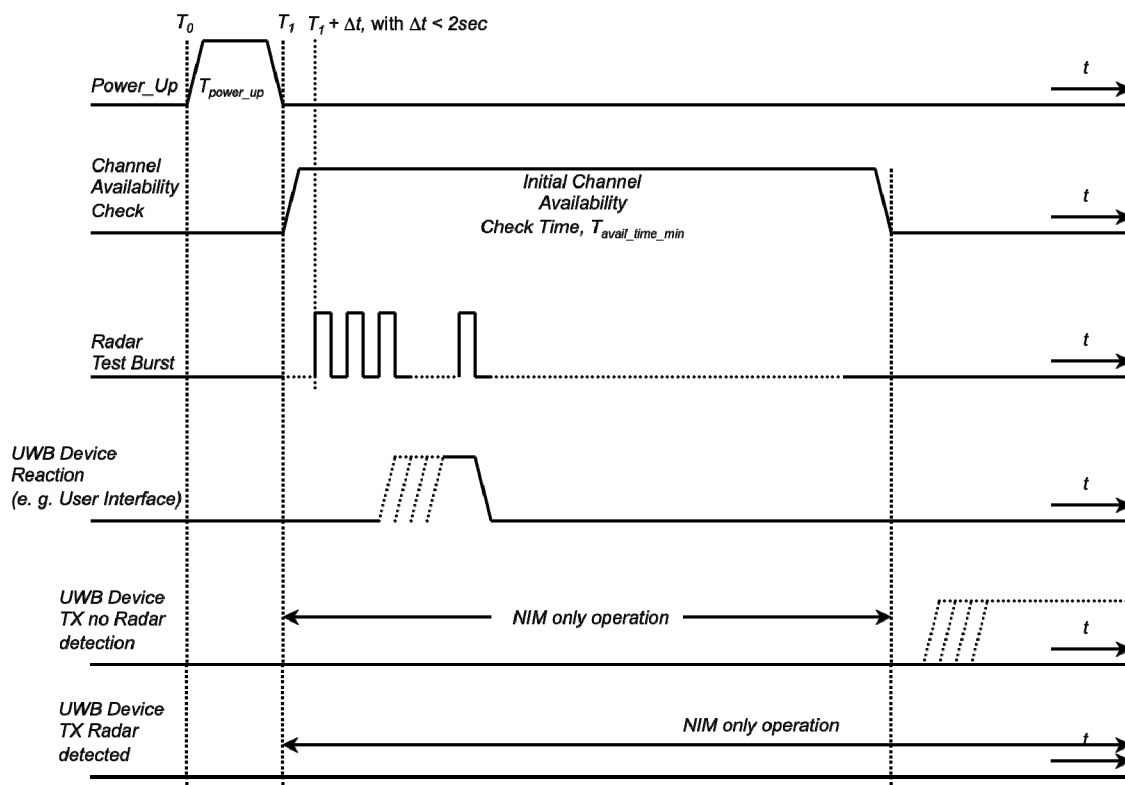

**Figure 3: Example of timing for radiolocation testing at the beginning of the Minimum Initial Channel Availability Check Time, UWB DAA radio device intent to operate in a non-NIM mode**

#### 5.8.7.2.3 Tests with radiolocation test signal at the end of the *Minimum Initial Channel Availability Check Time*, $T_{avail\_time\_min}$

##### Summary:

Verify the radar detection capability for the selected UWB operational frequency when a radar burst occurs at the end of the *Minimum Initial Channel Availability Check Time*. This is illustrated in Figure 4.

**Test description identifier:** TD\_Radar\_003

**Requirement Reference:** See Table 9

##### Pre-test Condition:

- UWB radio device supporting DAA
- UWB radio device switched off

##### Test Sequence:

- The UWB DAA radio device will be switched off. The signal generator used to generate the test patterns in Table 13 will be connected to an antenna of suitable characteristics to permit the UUT to be illuminated with a field equal to the threshold detection limit or connected to the corresponding connectors in the case of a conducted measurement setup.
- The UWB DAA radio device is powered up at  $T_0$ .  $T_1$  denotes the instant when the UWB DAA radio device has completed its power-up sequence ( $T_{power\_up}$ ), enters into the operational mode defined in Table 9 and is ready to start the radar detection.

**CON-1:** The *Minimum Initial Channel Availability Check*  $T_{avail\_time}$  is expected to commence at instant  $T_1$  and is expected to end no sooner than  $T_1 + T_{avail\_time}$  unless a radar is detected sooner.

NOTE: Additional verification may be needed to define  $T_1$  in case it is not exactly known or indicated by the UWB DAA radio device.

- c) A radar burst is generated in the relevant radiolocation frequency band using the radar test frequency and radar test signal #1 defined in Table 13 at a level of 10 dB above the level defined in annexes D and F. This single-burst radar test signal shall commence towards the end of the minimum required *Minimum Initial Channel Availability Check Time* but not before time  $T_1 + 10$  seconds.

**CON-2:** It shall be recorded if the radar test signal was detected. This can be done by verifying that the UWB DAA radio device is switched into a NIM operation in the relevant operational band using the *default avoidance bandwidth* of the regarded radiolocation service.

- d) Repeat b) to c) for 5 times in a row.

**CON-3:** CON-1 and CON-2 shall be fulfilled in all 5 tests. If CON-3 is fulfilled go to f). If one failure occurs go to e). For more than one failure the test has not been passed.

- e) Repeat b) to c) for 10 times in a row.

**CON-4:** CON-1 and CON-2 shall be fulfilled in all 10 tests.

- f) Repeat b) to e) for each of the relevant radar test signals for the UWB operational frequency range as defined in Table 13 at a level of 10 dB above the defined threshold level as defined in annex E and G and at exactly the threshold levels as defined in annexes E and G.

**CON-3:** A timing trace or description of the observed timing and behaviour of the UWB DAA radio device shall be recorded.

- g) Repeat b) to f) for each of the identified radar frequencies.

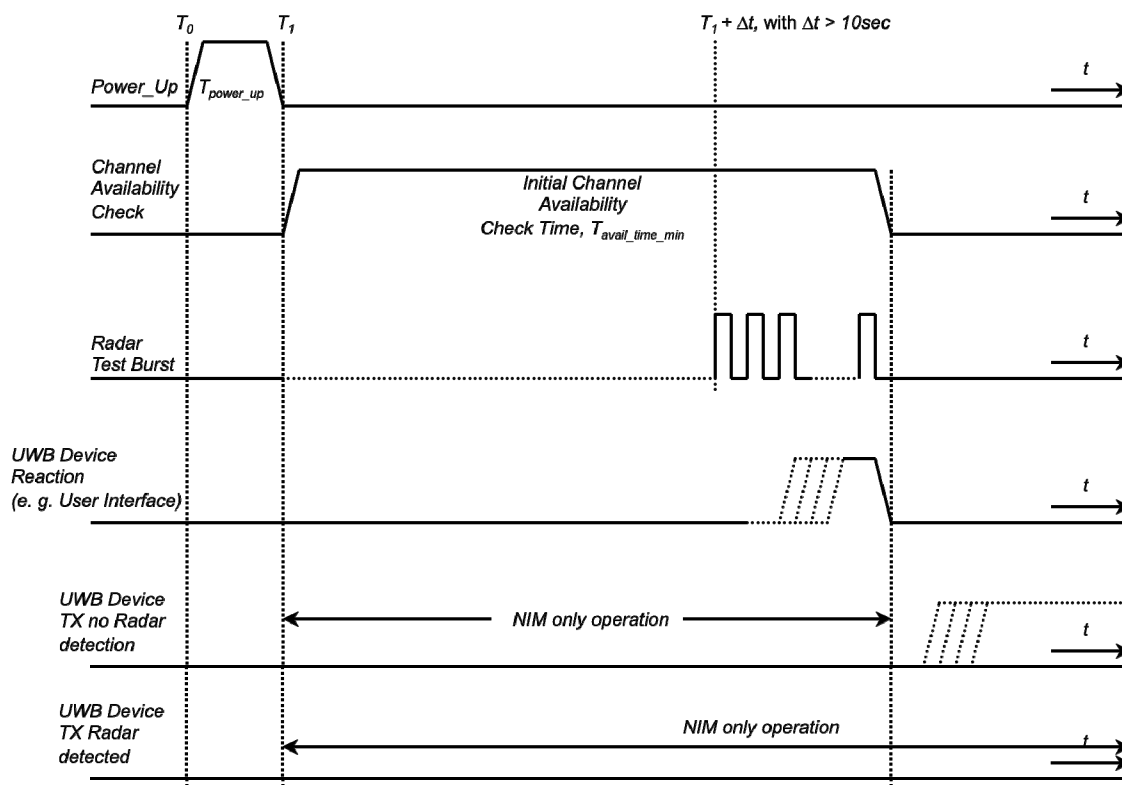
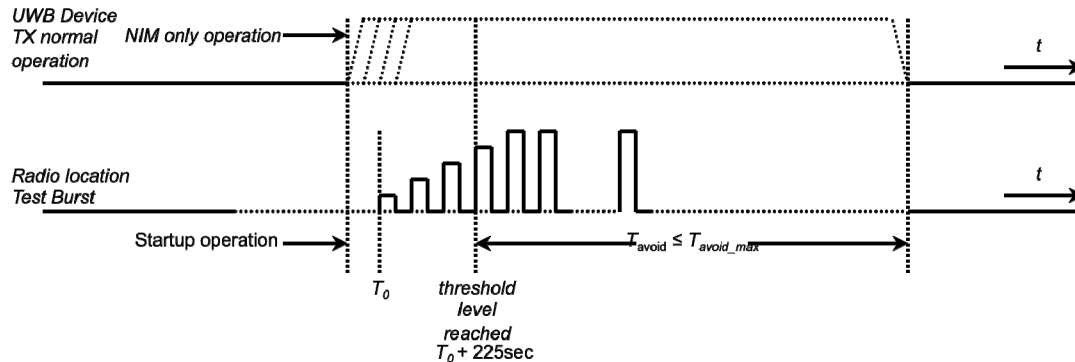

Figure 4: Example of timing for radar testing towards the end of the Minimum initial Channel Availability Check Time

### 5.8.7.3 In-operation test

The clauses below define the procedure to verify the *Detect and Avoid Time*,  $T_{\text{avoid}}$  by ensuring that the UWB DAA radio device is capable of detecting radiolocation system pulses during the normal operation of the UWB DAA radio device using a maximum mean EIRP power of -41,3 dBm/MHz which corresponds to a Zone 2 operation in the Radiolocation bands. This test should represent the relative movement of an UWB DAA radio device in relation to a potential victim radiolocation radio device. In Figure 5 an example for the used test signal is depicted. After the reach of the detection threshold level given in Table D.1 or F.1 respectively, the UWB DAA radio device shall switch into a NIM operation not later than  $T_{\text{avoid}}$ .



**Figure 5: Example of timing for radiolocation signal in-operation testing of the Detect and Avoid Time, here with increasing Radiolocation test signal level larger than the threshold**

#### 5.8.7.3.1 In-operation test procedure

##### Summary:

The procedure below verifies the radiolocation detection and avoidance capability for the selected UWB operational frequency in normal UWB operation using an increasing radiolocation test signal level. In this test the *Detect and Avoid time* and the corresponding avoidance operation will be verified. This is illustrated in Figure 5.

**Test description identifier:** TD\_Radar\_005

**Requirement Reference:** See Table 9

##### Pre-test Condition:

- Two UWB radio devices at least one supporting DAA
- Both UWB radio devices switched on
- UWB radio device in normal communication mode with a channel load of 50 %

##### Test Sequence:

- a) Both UWB DAA radio devices shall be switched on, enter the correct operational frequency band Table 8, and in a stable operational mode as defined in Table 9. The signal generator used to generate the test patterns in Table 13 will be connected to an antenna of suitable characteristics to permit the UUT to be illuminated with a field equal to the threshold detection limit or connected to the corresponding connectors in the case of a conducted measurement setup.
- b) The radiolocation test signal will be switched on at  $T_0$  with the test pattern in accordance with Table 13 at a power level 15 dB below the threshold identified in annex A and will be increased in 20 steps of 1 dB every 15 seconds progressively to reach the threshold +5 dB value at  $T_0 + 300$  seconds.

**CON-1:** The measurement of the actual "Detect and Avoid Time"  $T_{\text{avoid}}$  of the DUT is expected to commence at instant  $T_0 + 225$  seconds. The actual detect and avoid time of the radio device under test shall be smaller or equal to the Maximum Detect and Avoid time  $T_{\text{avoid\_max}}$  as defined in annex A. The actual Detect and Avoid time  $T_{\text{avoid}}$  of the radio device under test can be negative.

**CON-2:** It shall be recorded if the radar test signal was detected before  $T_0 + 225$  seconds +  $T_{\text{avoid\_max}}$ . This can be done by verifying that the UWB DAA radio device is switched into a NIM operation in the relevant operational band using the default avoidance bandwidth of the regarded radiolocation service.

c) Repeat b) for 5 times in a row.

**CON-3:** CON-1 and CON-2 shall be fulfilled in all 5 tests, then go to e). If one failure occurs go to d). For more than one failure the test has not been passed.

d) Repeat b) for 10 times in a row.

**CON-4:** CON-1 and CON-2 shall be fulfilled in all 10 tests.

e) Repeat b) to d) for each of the relevant radar test signals for the UWB operational frequency range as defined in Table 13 for the threshold levels as defined in annexes E and G.

**CON-5:** A timing trace or description of the observed timing and behaviour of the UWB DAA radio device shall be recorded.

f) Repeat b) to e) for each of the radar frequencies.

#### 5.8.7.4 Test patterns for the radiolocation DAA test

The general structure of radiolocation bursts is given in Figure 6. The test patterns to be used throughout testing, together with the relevant radar frequencies of operation are given in Table 13.

**Table 13: Parameters of radiolocation test signals**

Radar Test Frequencies (see note 11)	Radar test signal	Pulse width W [ $\mu$ s] (see note 5)	Pulse repetition frequency $f_{\text{PRF}}$ [pps] (see note 13)	Pulses per burst [PPB] (see notes 1 and 12)	Burst repetition frequency $f_{\text{BRF}}$ [bps]	Detection probability with 50 % channel load
$f_1 = 3,1$ GHz $f_1 < f_2 < f_3$ $f_3 = 3,4$ GHz	1 - Variable	20, 30, 40	400 to 1 400 (see note 6)	10 to 60	0,2 to 0,08	$P_d > 90$ %
$f_1 = 3,1$ GHz $f_1 < f_2 < f_3$ $f_3 = 3,4$ GHz	2 - Variable	10, 20, 40, 60, 100	100 to 500 (see note 6)	2 to 5	0,2 to 0,08	$P_d > 90$ %
$f_1 = 8,55$ GHz $f_1 < f_2 < f_3$ $f_3 = 8,95$ GHz	3 - Variable	1, 2, 5, 10, 15	5 000 to 15 000	20 to 560	2,0 to 0,22	$P_d > 90$ %

NOTE 1: This represents the number of pulses seen at the UWB DAA radio device per radar scan:

$$N = \{[\text{antenna beamwidth (deg)}] \times [\text{pulse repetition rate (pps)}]\} / \{[\text{scan rate (deg/s)}]\}.$$

Chose randomly a number of pulses in the given limits.

$$L = \text{PPB} \times 1/f_{\text{PRF}}, \text{ Burst length in seconds.}$$

NOTE 2: The test signals above only contain a single burst of pulses.

NOTE 3: The number of pulses per burst given in this table simulates real radar systems and takes into account the effects of pulse repetition rate and pulse width on the detection probability for a single burst.

NOTE 4:  $P_d$  gives the probability of detection per simulated radar burst and represents a minimum level of detection performance under defined conditions - in this case a 50 % traffic load.

Therefore  $P_d$  does not represent the overall detection probability for any particular radar under real life conditions. In general 2 sequential bursts are needed to achieve a real life detection rate of better than 99 % for any radar that falls within the scope of this table.

NOTE 5: The pulse width used in these tests is assumed to be representative of real radar systems with different pulse widths and different modulations. The pulse width is assumed to have an accuracy of  $\pm 10$  %.

NOTE 6: Chose PRF randomly in the given range.

NOTE 7: The burst repetition frequency  $f_{\text{BRF}}$  is used in the In-Service Monitoring test setup.

NOTE 8: The radar test signals 1 and 2 are to be used for the DAA radio device test in the band 3,1 GHz to 3,4 GHz.

NOTE 9: The radar test signals 3 are to be used for the DAA radio device test in the 8,5 GHz to 9 GHz.

NOTE 10: Pulses have instantaneous bandwidth of 0,5, 1, 2 or 5 MHz. Modulation types can be LFM, BPSK.

NOTE 11: The Radar Test Frequency  $f_2$  shall be arbitrarily chosen between the  $f_1$  and  $f_3$ .

NOTE 12: Suitable combinations of PPB and  $f_{\text{BRF}}$  are to be selected whereby for radar test signals 1 to 3, the minimum number of pulses per second is 2, 2/5 and 40 respectively. This clarifies note 1.

NOTE 13: The granularity for each radar test signal is 11 evenly distributed cases. The respective step sizes for radar test signals 1 to 3 are 100, 40 and 1 000.

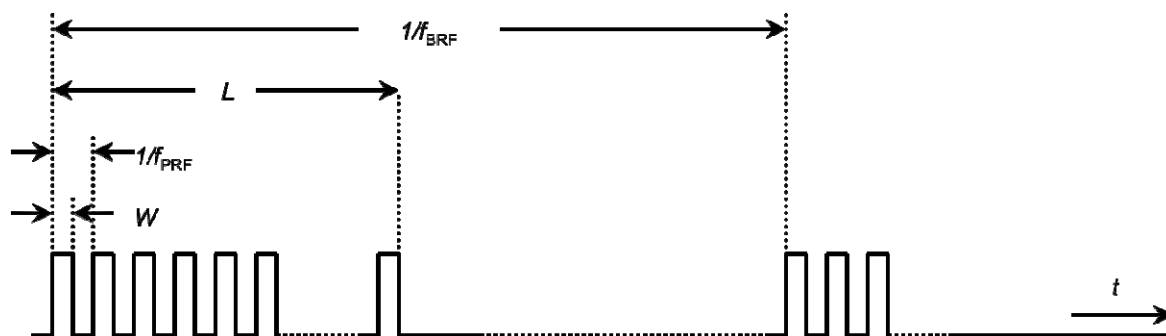

Figure 6: General structure of the bursts for DAA radiolocation test transmissions

## 5.8.8 Test Procedure for BWA systems in the band 3,4 GHz to 3,8 GHz

### 5.8.8.1 Introduction

The series of tests described in this clause emulates the operational conditions of a WiMax base station communicating with a WiMax subscriber collocated with a UWB enabled radio device. The possible range of performance evaluation tests might include assessment during preamble, data exchange and call termination between the two radio devices. In all cases the tests undertaken would establish that the minimum threshold detection levels, identified in the ECC decision and reproduced in annex B of TS 102 754 [5], can be met.

The current BWA systems deployed in Europe are all Time Division Duplex (TDD) however more recent developments have introduced Frequency Division Duplex (FDD) systems where the separation of carriers is approximately 200 MHz. The presently deployed BWA systems are fixed in nature although mobile systems are available these do not have significant market penetration. Nonetheless these further developments are anticipated in the present document and are tested for through the selective use of common bandwidth sizes and modulation schemes.

In both configurations, fixed or mobile, using either FDD or TDD in general the base station to subscriber link will present the lower power level to the UWB radio device and the nature of the signal, particularly the payload density, will correspond to the traffic type being carried. In the case of a collocated subscriber waking from idle and entering the start-up negotiation, the levels to be detected will be very much higher and, until data transfer begins, the signals periodic with no payload.

#### 5.8.8.1.1 UWB radio devices with and without victim service identification

To enhance spectrum utilisation, manufacturers may chose to implement victim service identification. Such a scheme allows the use of an extended range of optional avoidance mechanisms which will permit enhanced performance of the UWB radio device whilst assuring the victim service operation. The manufacturer will identify at the time of test whether the UWB radio device is equipped with victim service identification and the associated avoidance mechanisms implemented. These associated avoidance mechanisms will be evaluated.

### 5.8.8.2 Initial start-up test

The clauses below define the procedure to verify that the *Minimum Initial Channel Availability Check* time is met and that the UWB DAA radio device is capable of detecting BWA systems at the beginning and at the end of the *Minimum Channel Availability Check Time*. Thus the UWB DAA radio devices need to be set in a typical operational mode where a non NIM operation is required. Following the power up procedure the UWB radio device will enter the state identified in Table 9. The start-up test needs to be performed using all defined thresholds and optionally with a downlink signal deployed.

### 5.8.8.2.1 Test without a BWA test signal during the Minimum Initial Channel Availability Check Time, $T_{\text{avail\_time\_min}}$

#### Summary:

Verify that the UWB DAA radio device will not start transmitting in a non NIM operation before the end of the *Minimum Initial Channel Availability Check Time* under the condition that no BWA test signal is present.

**Test description identifier:** TD\_BWA\_006.

**Requirement Reference:** See Table 9.

#### Pre-test Condition:

- UWB radio device supporting DAA
- UWB radio device switched off

#### Test Sequence:

- a) The UWB DAA radio devices will be switched off. No victim signal generator is connected to the test setup or the signal generator is switched off in radiated test set-ups.
- b) The UWB DAA radio device is powered on at  $T_0$ .  $T_1$  denotes the instant when the UWB DAA radio device has completed its power-up sequence ( $T_{\text{power\_up}}$ ), has entered the correct operational frequency band shown in Table 8, is in a known state, identified in Table 9 and is ready to start the BWA detection.

**CON-1:** The UWB DAA radio device shall not switch into a mode other than a NIM before the end of  $T_1 + T_{\text{avail\_time\_min}}$  after switch on of the radio device, where the NIM operation is either the LDC mode or the power level defined in annex E for the relevant victim band.

NOTE: Additional verification may be needed to define  $T_1$  in case it is not exactly known or indicated by the UWB DAA radio device.

**CON-2:** A timing trace or description of the observed timing and behaviour of the UWB DAA radio device shall be recorded. An example is shown in Figure 2.

- c) Repeat b) for 5 times in a row.

**CON-3:** CON-1 and CON-2 shall be fulfilled in all 5 tests. If one failure occurs go to d). For more than one failure the test has not been passed.

- d) Repeat b) for 10 times in a row.

**CON-4:** CON-1 and CON-2 shall be fulfilled in all 10 tests.

- e) End of test.

### 5.8.8.2.2 Tests with a BWA test signal at the beginning of the *Minimum Initial Channel Availability Check Time*, $T_{\text{avail\_time}}$

#### Summary:

Verify the BWA detection and avoidance capability for the selected UWB operational frequency when a BWA signal occurs at the beginning of the *Minimum Initial Channel Availability Check Time*.

The UWB DAA radio device shall protect the complete *default avoidance bandwidth* as defined in annex F; this is a mandatory test for all UWB DAA radio devices. Where the UWB radio device is equipped with victim service identification, the *associated victim service identification avoidance mechanisms* and any other *optional avoidance mechanisms* identified by the manufacturer drawn from the avoidance RQ shall be specified and conformance established.

**Test description identifier:** TD\_BWA\_007.

**Requirement Reference:** See Table 9.

**Pre-test Condition:**

- UWB radio device supporting DAA
- UWB radio device switched off

**Test Sequence:**

- a) The UWB DAA radio device will be switched off. The signal generator used to generate the test patterns in Table 14 will be connected to an antenna of suitable characteristics to permit the UWB DAA radio device to be illuminated with a field intensity quantified below or connected to the corresponding connectors in the case of a conducted measurement setup deploying the same threshold limits defined in annex F.
- b) The UWB DAA radio device is powered on at  $T_0$ .  $T_1$  denotes the instant when the UWB DAA radio device has completed its power-up sequence ( $T_{\text{power\_up}}$ ), has entered the correct operational frequency band Table 8 and in a predefined state Table 9 and is ready to start the BWA detection.
- c) A BWA signal is generated in the relevant BWA frequency band using the web surfing test pattern defined in Table 14 at a level of 10 dB above each of the threshold levels defined in annex F. This BWA test signal shall commence within 1 second after time  $T_1$  and repeat for a minimum of 240 seconds.

**CON-1:** The *Minimum initial Channel Availability Check* time is expected to commence at  $T_1$  and is expected to end no sooner than  $T_1 + T_{\text{avail\_time\_min}}$  unless a BWA signal is detected sooner.

NOTE: Additional verification may be needed to define  $T_1$  in case it is not exactly known or indicated by the UWB DAA radio device.

**CON-2:** It shall be recorded if the BWA test signal was detected. This can be done by verifying that the UWB DAA radio device is switched into an avoid operation corresponding to the investigated threshold level in the relevant operational band or stays in a corresponding NIM operation. The following avoid operation parameter shall be verified:

- *default avoidance bandwidth* for the BWA service identified and where relevant
- *optional avoidance mechanisms* identified by the manufacturer for the BWA service identified
- LDC operational parameter if applicable

**CON-3:** A timing trace or description of the observed timing and behaviour of the UWB DAA radio device shall be recorded for each avoidance mechanism. An example is shown in Figure 3

- d) Repeat b) and c) for 5 times in a row.

**CON-4:** CON-1, CON-2 and CON-3 shall be fulfilled in all 5 tests. If one failure occurs go to d). For more than one failure the test has not been passed.

- e) Repeat a) to c) for 10 times in a row.

**CON-4:** CON-1 and CON-2 shall be fulfilled in all 10 tests.

- f) Repeat a) to e) at each of the threshold levels in annex E.

- g) Repeat a) to f) for each BWA operating frequency identified.

- h) If the UWB radio device has optional avoidance mechanisms, repeat a) to g) for each optional avoidance mechanism identified.

- i) If the UWB radio devices have Victim Service Identification implemented, re-establish the victim service as an Up-link down-link pair as identified in Table 14 and repeat steps a) to h) for each of the associated victim service identification avoidance mechanisms.

### 5.8.8.2.3 Tests with a BWA test signal at the end of the *Minimum Initial Channel Availability Check Time*, $T_{\text{avail\_time}}$

#### Summary:

Verify the BWA detection and avoidance capability for the selected UWB operational frequency when a BWA signal occurs at the end of the *Minimum Initial Channel Availability Check Time*.

The UWB DAA radio device shall protect the complete *default avoidance bandwidth* as defined in annex F; this is a mandatory test for all UWB DAA radio devices. Where the UWB radio device is equipped with victim service identification, the *associated victim service identification avoidance mechanisms* and any other *optional avoidance mechanisms* identified by the manufacturer drawn from the avoidance RQ shall be specified and conformance established.

**Test description identifier:** TD\_BWA\_008

**Requirement Reference:** See Table 9

#### Pre-test Condition:

- UWB radio device supporting DAA
- UWB radio device switched off

#### Test Sequence:

- a) The UWB DAA radio device will be switched off. The signal generator used to generate the test patterns in Table 14 will be connected to an antenna of suitable characteristics to permit the UWB DAA radio device to be illuminated with a field intensity quantified below or connected to the corresponding connectors in the case of a conducted measurement setup deploying the same threshold limits defined in annex F.
- b) The UWB DAA radio device is powered on at  $T_0$ .  $T_1$  denotes the instant when the UWB DAA radio device has completed its power-up sequence ( $T_{\text{power\_up}}$ ), has entered the correct operational frequency band (Table 8) and in a predefined state (Table 9) and is ready to start the BWA detection.
- c) A BWA signal is generated in the relevant BWA frequency band using the web surfing test pattern defined in Table 14 a level of 10 dB above each of the threshold levels defined in annex F. This BWA test signal shall commence towards the end of the minimum required Minimum Initial Channel Availability Check Time but not before time  $T_1 + 3$  seconds and repeat for a minimum of 240 seconds.

**CON-1:** The *Minimum initial Channel Availability Check* time is expected to commence at  $T_1$  and is expected to end no sooner than  $T_1 + T_{\text{avail\_time\_min}}$  unless a BWA signal is detected sooner.

NOTE: Additional verification may be needed to define  $T_1$  in case it is not exactly known or indicated by the UWB DAA radio device.

**CON-2:** It shall be recorded if the BWA test signal was detected. This can be done by verifying that the UWB DAA radio device is switched into an avoid operation corresponding to the investigated threshold level in the relevant operational band or stays in a corresponding NIM operation. The following avoid operations shall be verified:

- *default avoidance bandwidth* for the BWA service identified and where relevant
- *optional avoidance mechanisms* identified by the manufacturer for the BWA service identified
- LDC operational parameter if applicable

**CON-3:** A timing trace or description of the observed timing and behaviour of the UWB DAA radio device shall be recorded for each avoidance mechanism.

- d) Repeat b) and c) for 5 times in a row.

**CON-4:** CON-1, CON-2 and CON-3 shall be fulfilled in all 5 tests. If one failure occurs go to d). For more than one failure the test has not been passed.



- e) Repeat b) and c) for 10 times in a row.

**CON-5:** CON-1, CON-2 and CON-3 shall be fulfilled in all 10 tests.

- f) Repeat b) to e) at each of the threshold levels in annex F.
- g) Repeat b) to f) for each BWA operating frequency identified.
- h) If the UWB radio device has optional avoidance mechanisms, repeat b) to g) for each *optional avoidance mechanism* identified.
- i) If the UWB radio devices have Victim Service Identification implemented, re-establish the victim service as an Up-link down-link pair as identified in Table 14 and repeat steps b) to h) for each of the *associated victim service identification avoidance mechanisms*.

### 5.8.8.3 In-operation test

This series of tests evaluates the UWB radio device's response to the presence of different payload types which the victim service may carry. The range of services was defined by the ECC and is reproduced in annex F. Each service requires a different response time from the UWB radio device and these are also recorded in annex F.

The in-operation is different from the start-up tests previously identified only in as much as the UWB pair will be actively exchanging data and the victim signal will also be an established transmission. In this test the *Detect and Avoid time* will be recorded and the corresponding avoidance operation will be verified.

#### Summary:

Verify the BWA detection and avoidance capability for the selected UWB operational frequency when a BWA signal occurs during the normal exchange of data between two active UWB radio devices.

The UWB DAA radio device shall protect the complete *default avoidance bandwidth* as defined in annex F; this is a mandatory test for all UWB DAA radio devices. Where the UWB radio device is equipped with victim service identification, the *associated victim service identification avoidance mechanisms* and any other *optional avoidance mechanisms* identified by the manufacturer drawn from the avoidance RQ shall be specified and conformance established.

**Test description identifier:** TD\_BWA\_009.

**Requirement Reference:** See Table 9.

#### Pre-test Condition:

- i. Two UWB radio devices with at least one supporting DAA.
- ii. Both UWB radio devices switched on and exchanging data.

#### Test Sequence:

- a) Both UWB DAA radio devices shall be switched on, enter the correct operational frequency band Table 8 and in a stable operational mode and the payload defined in Table 9. The signal generator used to generate the test patterns in Table 14 will be connected to an antenna of suitable characteristics to permit the UUT to be illuminated with a field intensity defined below or connected to the corresponding connectors in the case of a conducted measurement setup.
- b) The BWA test signal will be switched on at  $T_0$  with the test pattern in accordance with Table 14 at a power level 15 dB below the threshold identified in annex E and will be increased in 20 steps of 1 dB every 15 seconds progressively to reach the threshold +5 dB value at  $T_0 + 300$  seconds.

**CON-1:** The measurement of the actual "Detect and Avoid Time"  $T_{\text{avoid}}$  of the DUT is expected to commence at instant  $T_0 + 225$  seconds. The actual detect and avoid time of the radio device under test shall be smaller or equal to the Maximum Detect and Avoid time  $T_{\text{avoid\_max}}$ . The actual Detect and Avoid time  $T_{\text{avoid}}$  of the radio device under test can be negative. The following avoid operations shall be verified:

- *default avoidance bandwidth* for the BWA service identified and where relevant
- *optional avoidance mechanisms* identified by the manufacturer for the BWA service identified

- LDC operational parameter if applicable

**CON-2:** A timing trace or description of the observed timing and behaviour of the UWB DAA radio device shall be recorded for each test case. An example is shown in Figure 5.

- c) Repeat b) and c) for 5 times in a row.

**CON-3:** CON-1 and CON-2 shall be fulfilled in all 5 tests. If one failure occurs go to d). For more than one failure the test has not been passed.

- d) Repeat b) and c) for 10 times in a row.

**CON-4:** CON-1 and CON-2 shall be fulfilled in all 10 tests.

- e) Repeat b) for each threshold in annex E

**NOTE:** Instead of repeating the test for each threshold, continuous testing for the different thresholds can also be performed. Depending on the implemented avoidance strategy, some threshold tests may be redundant, i.e. one test already covers another case.

- f) Repeat b) and c) for each service identified in Table 14.

- g) Repeat c) to e) for each BWA operating frequency identified.

- h) If the UWB radio device has optional avoidance mechanisms, repeat c) to f) for each optional avoidance mechanism identified.

- i) If the UWB radio devices have Victim Service Identification implemented, re-establish the victim service as an Up-link down-link pair as identified in Table 14 and repeat steps c) to f) for each of the associated victim service identification avoidance mechanisms.

#### 5.8.8.4 Test Patterns for BWA Testing

The test patterns to be used throughout testing for the services identified in Table 14, will display the periodicity of signals given in Figure 9. The details of each burst for each service is given are given in Table 14.

**Table 14: Test patterns for BWA testing**

Service/Operational Status	Operational Frequencies (see note 1)	Test Pattern BW 7 MHz (see note 2)
VoIP	3,41 GHz, 3,5 GHz,	9 OFDMA symbols frame each at intervals identified in Figure 9
Web Surfing	3,459 GHz, 3,61 GHz,	
Broadcast	3,7 GHz, 3,79 GHz	
NOTE 1: Where Up-link down-link pairs are required these shall be centred symmetrically around the frequencies 3,5 GHz and 3,7 GHz. The down link level shall be at each of the threshold levels.		
NOTE 2: Most BWA systems operated in the future in Europe will be based on mobile WiMax with a bandwidth of 5 MHz, 7 MHz or 10 MHz. Thus the chosen 7 MHz test signal bandwidth is representative of the current and future BWA deployment in Europe. A relevant subcarrier modulation scheme shall be chosen (QPSK, 16QAM or 64QAM).		
NOTE 3: For a 7 MHz-bandwidth WiMAX signal the number of physical radio subcarriers is fixed and it is 1 024 where 841 subcarriers are used within a symbol and the rest are guard (left, right) subcarriers. The number of subchannels used (groups of logical subcarriers) can be varied between 0 and 34 but this variation has almost no impact in the final transmitted spectrum power and there is no variation in the bandwidth of the WiMAX signal. This may have little impact on the number of detections reported by the EUT. The influence of using different modulation schemes (QPSK, 16QAM and 64QAM) may also have little impact in the detection results from one scheme to another.		

**Figure 7: Void**

**Figure 8: Void**

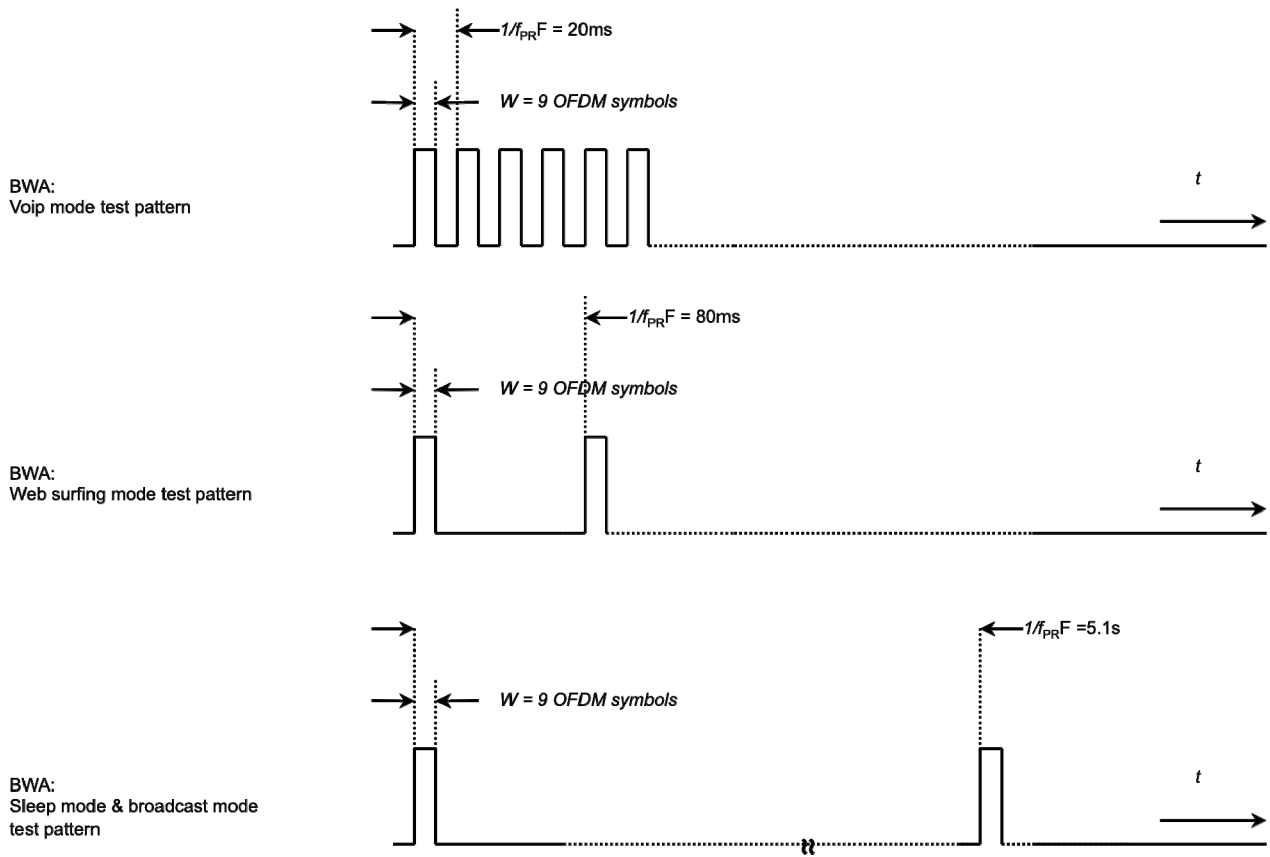

Figure 9: Timing of BWA test signals

---

## Annex A (normative): HS Requirements and conformance Test specifications Table (HS-RTT)

The HS Requirements and conformance Test specifications Table (HS-RTT) in Table A.1 serves a number of purposes, as follows:

- it provides a statement of all the requirements in words and by cross reference to (a) specific clause(s) in the present document or to (a) specific clause(s) in (a) specific referenced document(s);
- it provides a statement of all the test procedures corresponding to those requirements by cross reference to (a) specific clause(s) in the present document or to (a) specific clause(s) in (a) specific referenced document(s);
- it qualifies each requirement to be either:
  - Unconditional: meaning that the requirement applies in all circumstances, or
  - Conditional: meaning that the requirement is dependant on the manufacturer having chosen to support optional functionality defined within the schedule.
- in the case of Conditional requirements, it associates the requirement with the particular optional service or functionality;
- it qualifies each test procedure to be either:
  - Essential: meaning that it is included with the Essential Radio Test Suite and therefore the requirement shall be demonstrated to be met in accordance with the referenced procedures;
  - Other: meaning that the test procedure is illustrative but other means of demonstrating compliance with the requirement are permitted.

**Table A.1: HS Requirements and conformance Test specifications Table (HS-RTT)**

<b>Harmonized Standard EN 302 065</b>						
The following requirements and test specifications are relevant to the presumption of conformity under the article 3.2 of the R&TTE Directive						
<b>Requirement</b>			<b>Requirement Conditionality</b>		<b>Test specification</b>	
<b>No</b>	<b>Description</b>	<b>Reference: clause No</b>	<b>U/C</b>	<b>Condition</b>	<b>E/O</b>	<b>Reference: clause No</b>
1	Operating bandwidth	4.1.1	U	.	E	5.8.4
2	Maximum value of mean power spectral density	4.1.2	U		E	5.8.2
3	Maximum value of peak power	4.1.3	U		E	5.8.3
4	Transmit Power Control	4.1.4	C	Applies only to equipment having TPC implemented	E	5.8.2
5	Receiver spurious emissions	4.1.5	C	Applies only to equipment that can be operated in a receive-only mode	E	5.8.5
6a	Detect-and-avoid	4.1.6	C	Applies only to equipment operating in the frequency band 3,1 GHz to 4,8 GHz and having DAA	E	5.8.7, 5.8.8, annexes D and E
6b	Detect-and-avoid	4.1.6	C	Applies only to equipment operating in the frequency band 8,5 GHz to 9 GHz and having DAA	E	5.8.7 and annex F
7	Low Duty Cycle	4.1.7	C	Applies only to equipment with LDC implemented: 3,1 to 4,8 (alternative to DAA-1 and DAA-2) -> (DAA-1 + DAA-2) OR LDC  for cars: (DAA-1 + DAA-2 + TPC) OR LDC (latter option, it is not mandatory to implement the whole range)  6-8,5: in cars, alternative to TPC  8,5-9: DAA-3 in cars: (DAA-3 + TPC) OR (DAA-3 + LDC)	O	5.8.6
8	Equivalent Mitigation Techniques	4.1.8	C	Applies only to equipment using equivalent mitigation techniques	X	

**Key to columns:****Requirement:**

**No** A unique identifier for one row of the table which may be used to identify a requirement or its test specification.

**Description** A textual reference to the requirement.

**Clause Number** Identification of clause(s) defining the requirement in the present document unless another document is referenced explicitly.

**Requirement Conditionality:**

**U/C** Indicates whether the requirement is to be *unconditionally* applicable (U) or is *conditional* upon the manufacturers claimed functionality of the equipment (C).

**Condition** Explains the conditions when the requirement shall or shall not be applicable for a technical requirement which is classified "conditional".

**Test Specification:**

**E/O** Indicates whether the test specification forms part of the Essential Radio Test Suite (E) or whether it is one of the Other Test Suite (O).

**NOTE:** All tests whether "E" or "O" are relevant to the requirements. Rows designated "E" collectively make up the Essential Radio Test Suite; those designated "O" make up the Other Test Suite; for those designated "X" there is no test specified corresponding to the requirement. The completion of all tests classified "E" as specified with satisfactory outcomes is a necessary condition for a presumption of conformity. Compliance with requirements associated with tests classified "O" or "X" is a necessary condition for presumption of conformity, although conformance with the requirement may be claimed by an equivalent test or by manufacturer's assertion supported by appropriate entries in the technical construction file.

**Clause Number** Identification of clause(s) defining the test specification in the present document unless another document is referenced explicitly. Where no test is specified (that is, where the previous field is "X") this field remains blank.

## Annex B (normative): Radiated measurements

### B.1 Test sites and general arrangements for measurements involving the use of radiated fields

This annex introduces the test site which may be used for radiated tests. The test site is generally referred to as a free field test site. Both absolute and relative measurements can be performed in these sites. Where absolute measurements are to be carried out, the chamber should be verified. A detailed verification procedure is described in TS 102 321 [4].

#### B.1.1 Anechoic chamber

An anechoic chamber is the preferred test site to be used for radiated testing in accordance with the present document above 1 GHz. However, an anechoic chamber with ground plane as described in clause B.1.2 may be used above 1 GHz providing that suitable anechoic material is placed on the chamber floor to suppress any reflected signal.

An anechoic chamber is an enclosure, usually shielded, whose internal walls, floor and ceiling are covered with radio absorbing material, normally of the pyramidal urethane foam type. The chamber usually contains an antenna support at one end and a turntable at the other. A typical anechoic chamber is shown in Figure B.1.

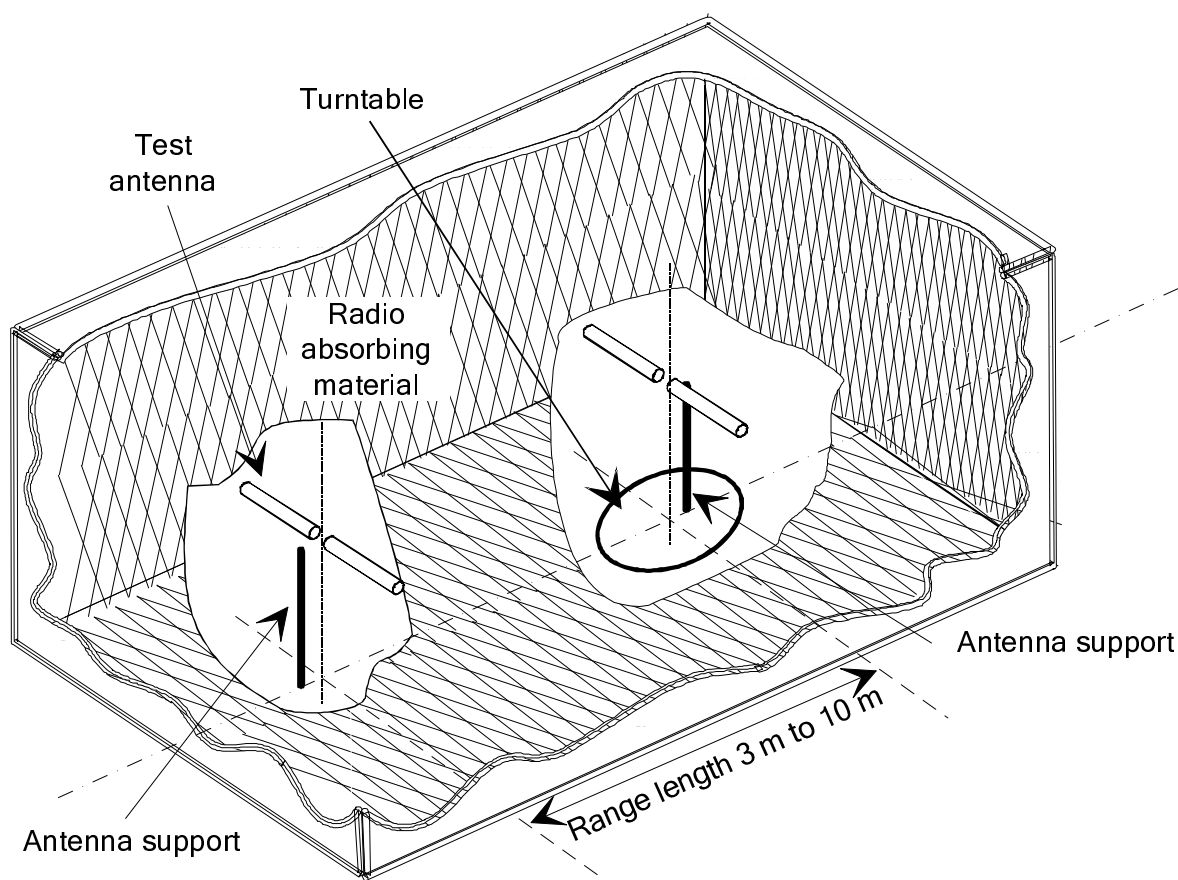

Figure B.1: A typical anechoic chamber

The chamber shielding and radio absorbing material work together to provide a controlled environment for testing purposes. This type of test chamber attempts to simulate free space conditions.

The shielding provides a test space, with reduced levels of interference from ambient signals and other outside effects, whilst the radio absorbing material minimizes unwanted reflections from the walls and ceiling which can influence the measurements. In practice it is relatively easy for shielding to provide high levels (80 dB to 140 dB) of ambient interference rejection, normally making ambient interference negligible.

A turntable is capable of rotation through 360° in the horizontal plane and it is used to support the test sample (EUT) at a suitable height (e.g. 1 m) above the ground plane. The chamber shall be large enough to allow the measuring distance of at least 3 m or  $2(d_1 + d_2)^2/\lambda$  (m), whichever is greater (see clause B.2.5). However, it shall be noted that due to the low radiated power density for UWB equipment, its transmit spectrum can be measured at approximately 1 m to improve measurement sensitivity. The distance used in actual measurements shall be recorded with the test results. Practical tests have shown that larger measurement distances of up to 3 meters at the frequencies below 1 GHz and shorter measurement distances of less than 1 meter at frequencies above 10 GHz can be conducted as long as the far field conditions are still fulfilled.

The anechoic chamber generally has several advantages over other test facilities. There is minimal ambient interference, minimal floor, ceiling and wall reflections and it is independent of the weather. It does however have some disadvantages which include limited measuring distance and limited lower frequency usage due to the size of the pyramidal absorbers. To improve low frequency performance, a combination structure of ferrite tiles and urethane foam absorbers is commonly used.

All types of emission testing can be carried out within an anechoic chamber without limitation.

## B.1.2 Anechoic chamber with a conductive ground plane

An anechoic chamber with a conductive ground plane shall be used for radiated testing in accordance with the present document below 1 GHz.

An anechoic chamber with a conductive ground plane is an enclosure, usually shielded, whose internal walls and ceiling are covered with radio absorbing material, normally of the pyramidal urethane foam type. The floor, which is metallic, is not covered and forms the ground plane. The chamber usually contains an antenna mast at one end and a turntable at the other. A typical anechoic chamber with a conductive ground plane is shown in Figure B.2.

This type of test chamber attempts to simulate an ideal Open Area Test Site whose primary characteristic is a perfectly conducting ground plane of infinite extent.



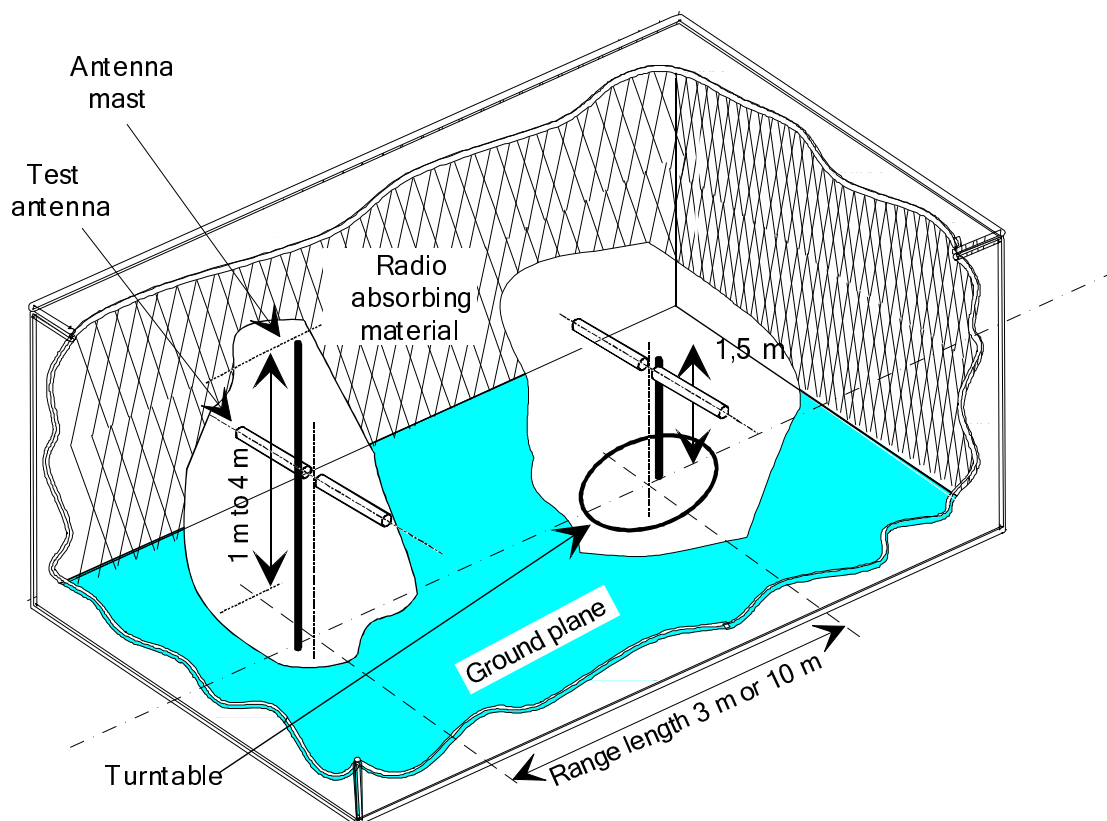

**Figure B.2: A typical anechoic chamber with a conductive ground plane**

In this facility the ground plane creates the wanted reflection path, such that the signal received by the receiving antenna is the sum of the signals from both the direct and reflected transmission paths. This creates a unique received signal level for each height of the transmitting antenna (or EUT) and the receiving antenna above the ground plane.

The antenna mast provides a variable height facility (from 1 m to 4 m) so that the position of the test antenna can be optimized for maximum coupled signal between antennas or between a EUT and the test antenna.

A turntable is capable of rotation through  $360^\circ$  in the horizontal plane and it is used to support the test sample (EUT) at a specified height, usually 1,5 m above the ground plane. The chamber shall be large enough to allow the measuring distance of at least 3 m or  $2(d_1 + d_2)^2 / \lambda$  (m), whichever is greater (see clause A.2.5). However, it shall be noted that due to the low radiated power density for UWB equipment it's transmit spectrum can be measured at approximately 1 m. The distance used in actual measurements shall be recorded with the test results.

Emission testing involves firstly "peaking" the field strength from the EUT by raising and lowering the receiving antenna on the mast (to obtain the maximum constructive interference of the direct and reflected signals from the EUT) and then rotating the turntable for a "peak" in the azimuth plane. At this height of the test antenna on the mast, the amplitude of the received signal is noted. Secondly the EUT is replaced by a substitution antenna (positioned at the EUT's phase or volume centre), which is connected to a signal generator. The signal is again "peaked" and the signal generator output adjusted until the level, noted in stage one, is again measured on the receiving radio device.

Receiver sensitivity tests over a ground plane also involve "peaking" the field strength by raising and lowering the test antenna on the mast to obtain the maximum constructive interference of the direct and reflected signals, this time using a measuring antenna which has been positioned where the phase or volume centre of the EUT will be during testing. A transform factor is derived. The test antenna remains at the same height for stage two, during which the measuring antenna is replaced by the EUT. The amplitude of the transmitted signal is reduced to determine the field strength level at which a specified response is obtained from the EUT.

### B.1.3 Test antenna

A test antenna is always used in radiated test methods. In emission tests (i.e. effective radiated power, spurious emissions) the test antenna is used to detect the field from the EUT in one stage of the measurement and from the substitution antenna in the other stage. When the test site is used for the measurement of receiver characteristics (i.e. sensitivity and various immunity parameters) the antenna is used as the transmitting radio device.

The test antenna should be mounted on a support capable of allowing the antenna to be used in either horizontal or vertical polarization which, on ground plane sites (i.e. anechoic chambers with ground plane) should additionally allow the height of its centre above the ground to be varied over the specified range (usually 1 m to 4 m).

In the frequency band 30 MHz to 1 000 MHz, dipole antennas (constructed in accordance with ANSI C63.5 [2]) are generally recommended. For frequencies of 80 MHz and above, the dipoles should have their arm lengths set for resonance at the frequency of test. Below 80 MHz, shortened arm lengths are recommended. For spurious emission testing, however, a combination of bicones and log periodic dipole array antennas (commonly termed "log periodics") could be used to cover the entire 30 MHz to 1 000 MHz band. Above 1 000 MHz, waveguide horns are recommended although, again, log periodics could be used.

NOTE: The gain of a horn antenna is generally expressed relative to an isotropic radiator.

### B.1.4 Substitution antenna

The substitution antenna is used to replace the EUT for tests in which a transmitting parameter (i.e. frequency error, effective radiated power, spurious emissions and adjacent channel power) is being measured. For measurements in the frequency band 30 MHz to 1 000 MHz, the substitution antenna should be a dipole antenna (constructed in accordance with ANSI C63.5 [2]). For frequencies of 80 MHz and above, the dipoles should have their arm lengths set for resonance at the frequency of test. Below 80 MHz, shortened arm lengths are recommended. For measurements above 1 000 MHz, a waveguide horn is recommended. The centre of this antenna should coincide with either the phase centre or volume centre.

### B.1.5 Measuring antenna

The measuring antenna is used in tests on a EUT in which a receiving parameter (i.e. sensitivity and various immunity tests) is being measured. Its purpose is to enable a measurement of the electric field strength in the vicinity of the EUT. For measurements in the frequency band 30 MHz to 1 000 MHz, the measuring antenna should be a dipole antenna (constructed in accordance with ANSI C63.5 [2]). For frequencies of 80 MHz and above, the dipoles should have their arm lengths set for resonance at the frequency of test. Below 80 MHz, shortened arm lengths are recommended. The centre of this antenna should coincide with either the phase centre or volume centre (as specified in the test method) of the EUT.

---

## B.2 Guidance on the use of a radiation test site

This clause details procedures, test equipment arrangements and verification that should be carried out before any of the radiated tests are undertaken.

### B.2.1 Verification of the test site

No test should be carried out on a test site which does not possess a valid certificate of verification. The verification procedures for the different types of test sites described in annex A (i.e. anechoic chamber and anechoic chamber with a ground plane) are given in the relevant parts of TR 102 273 [i.7] or equivalent.

## B.2.2 Preparation of the EUT

The manufacturer should supply information about the EUT covering the operating frequency, polarization, supply voltage(s) and the reference face. Additional information, specific to the type of EUT should include, where relevant, carrier power, channel separation, whether different operating modes are available (e.g. high and low power modes) and if operation is continuous or is subject to a maximum test duty cycle (e.g. 1 minute on, 4 minutes off).

Where necessary, a mounting bracket of minimal size should be available for mounting the EUT on the turntable. This bracket should be made from low conductivity, low relative dielectric constant (i.e. less than 1,5) material(s) such as expanded polystyrene, balsa wood, etc.

## B.2.3 Power supplies to the EUT

All tests should be performed using power supplies wherever possible, including tests on EUT designed for battery-only use. In all cases, power leads should be connected to the EUT's supply terminals (and monitored with a digital voltmeter) but the battery should remain present, electrically isolated from the rest of the equipment, possibly by putting tape over its contacts.

The presence of these power cables can, however, affect the measured performance of the EUT. For this reason, they should be made to be "transparent" as far as the testing is concerned. This can be achieved by routing them away from the EUT and down to either the screen, ground plane or facility wall (as appropriate) by the shortest possible paths. Precautions should be taken to minimize pick-up on these leads (e.g. the leads could be twisted together, loaded with ferrite beads at 0,15 m spacing or otherwise loaded).

## B.2.4 Range length

The range length for all these types of test facility should be adequate to allow for testing in the far field of the EUT i.e. it should be equal to or exceed:

$$\frac{2(d_1 + d_2)^2}{\lambda}$$

where:

$d_1$  is the largest dimension of the EUT/dipole after substitution (m);

$d_2$  is the largest dimension of the test antenna (m);

$\lambda$  is the test frequency wavelength (m).

It should be noted that in the substitution part of this measurement, where both test and substitution antennas are half wavelength dipoles, this minimum range length for far-field testing would be:

$$2\lambda$$

It should be noted in test reports when either of these conditions is not met so that the additional measurement uncertainty can be incorporated into the results.

NOTE 1: For the fully anechoic chamber, no part of the volume of the EUT should, at any angle of rotation of the turntable, fall outside the "quiet zone" of the chamber at the nominal frequency of the test.

NOTE 2: The "quiet zone" is a volume within the anechoic chamber (without a ground plane) in which a specified performance has either been proven by test, or is guaranteed by the designer/manufacturer. The specified performance is usually the reflectivity of the absorbing panels or a directly related parameter (e.g. signal uniformity in amplitude and phase). It should be noted however that the defining levels of the quiet zone tend to vary.

## B.2.5 Site preparation

The cables for both ends of the test site should be routed horizontally away from the testing area for a minimum of 2 m and then allowed to drop vertically and out through either the ground plane or screen (as appropriate) to the test equipment. Precautions should be taken to minimize pick up on these leads (e.g. dressing with ferrite beads, or other loading). The cables, their routing and dressing should be identical to the verification set-up.

Calibration data for all items of test equipment should be available and valid. For test, substitution and measuring antennas, the data should include gain relative to an isotropic radiator (or antenna factor) for the frequency of test. Also, the VSWR of the substitution and measuring antennas should be known.

The calibration data on all cables and attenuators should include insertion loss and VSWR throughout the entire frequency range of the tests. All VSWR and insertion loss figures should be recorded in the logbook results sheet for the specific test.

Where correction factors/tables are required, these should be immediately available.

For all items of test equipment, the maximum measurement uncertainty they exhibit should be known along with the distribution of the uncertainty.

At the start of measurements, system checks should be made on the items of test equipment used on the test site.

---

## B.3 Coupling of signals

### B.3.1 General

The presence of leads in the radiated field may cause a disturbance of that field and lead to additional measurement uncertainty. These disturbances can be minimized by using suitable coupling methods, offering signal isolation and minimum field disturbance (e.g. optical and acoustic coupling).

### B.3.2 Data Signals

Isolation can be provided by the use of optical, ultrasonic or infrared means. Field disturbance can be minimized by using a suitable fibre optic connection. Ultrasonic or infrared radiated connections require suitable measures for the minimization of ambient noise.

---

## B.4 Standard test methods

Two methods of determining the radiated power of a radio device are described in clauses B.4.1 and B.4.2.

### B.4.1 Calibrated setup

The measurement receiver, test antenna and all associated equipment (e.g. cables, filters, amplifiers, etc.) shall have been recently calibrated against known standards at all the frequencies on which measurements of the equipment are to be made. A suggested calibration method is given in clause B.5.

On a test site according to clause B.1, the equipment shall be placed at the specified height on a support, and in the position closest to normal use as declared by the provider.

The test antenna shall be oriented initially for vertical polarization and shall be chosen to correspond to the frequency of the transmitter.

The output of the test antenna shall be connected to the spectrum analyser via whatever (fully characterized) equipment is required to render the signal measurable (e.g. amplifiers).

The transmitter shall be switched on, if possible without modulation, and the spectrum analyser shall be tuned to the frequency of the transmitter under test.

The test antenna shall be raised and lowered through the specified range of height until a maximum signal level is detected by the spectrum analyser.

The transmitter shall then be rotated through 360° in the horizontal plane, until the maximum signal level is detected by the spectrum analyser.

The test antenna shall be raised and lowered again through the specified range of height until a maximum signal level is detected by the spectrum analyser.

The maximum signal level detected by the spectrum analyser shall be noted and converted into the radiated power by application of the pre-determined calibration coefficients for the equipment configuration used.

## B.4.2 Substitution method

On a test site, selected from clause B.1, the equipment shall be placed at the specified height on a support, as specified in clause B.1, and in the position closest to normal use as declared by the provider.

The test antenna shall be oriented initially for vertical polarization and shall be chosen to correspond to the frequency of the transmitter.

The output of the test antenna shall be connected to the spectrum analyser.

The transmitter shall be switched on, if possible without modulation, and the measuring receiver shall be tuned to the frequency of the transmitter under test.

The test antenna shall be raised and lowered through the specified range of height until a maximum signal level is detected by the spectrum analyser.

The transmitter shall then be rotated through 360° in the horizontal plane, until the maximum signal level is detected by the spectrum analyser.

The test antenna shall be raised and lowered again through the specified range of height until a maximum signal level is detected by the spectrum analyser.

The maximum signal level detected by the spectrum analyser shall be noted.

The transmitter shall be replaced by a substitution antenna as defined in clause B.1.4.

The substitution antenna shall be orientated for vertical polarization and the length of the substitution antenna shall be adjusted to correspond to the frequency of the transmitter.

The substitution antenna shall be connected to a calibrated signal generator.

If necessary, the input attenuator setting of the spectrum analyser shall be adjusted in order to increase the sensitivity of the spectrum analyser.

The test antenna shall be raised and lowered through the specified range of height to ensure that the maximum signal is received. When a test site according clause B.1.1 is used, the height of the antenna shall not be varied.

The input signal to the substitution antenna shall be adjusted to the level that produces a level detected by the spectrum analyser, that is equal to the level noted while the transmitter radiated power was measured, corrected for the change of input attenuator setting of the spectrum analyser.

The input level to the substitution antenna shall be recorded as power level, corrected for any change of input attenuator setting of the spectrum analyser.

The measurement shall be repeated with the test antenna and the substitution antenna orientated for horizontal polarization.

The measure of the radiated power of the radio device is the larger of the two levels recorded at the input to the substitution antenna, corrected for gain of the substitution antenna if necessary.

## B.5 Standard calibration method

The calibration of the test fixture establishes the relationship between the detected output from the test fixture, and the transmitted power (as sampled at the position of the antenna) from the EUT in the test fixture. This can be achieved (at higher frequencies) by using a calibrated horn with a gain of equal to or less than 20 dB, fed from an external signal source, in place of the EUT to determine the variations in detected power over frequency.

The calibration setup is shown in Figure B.3.

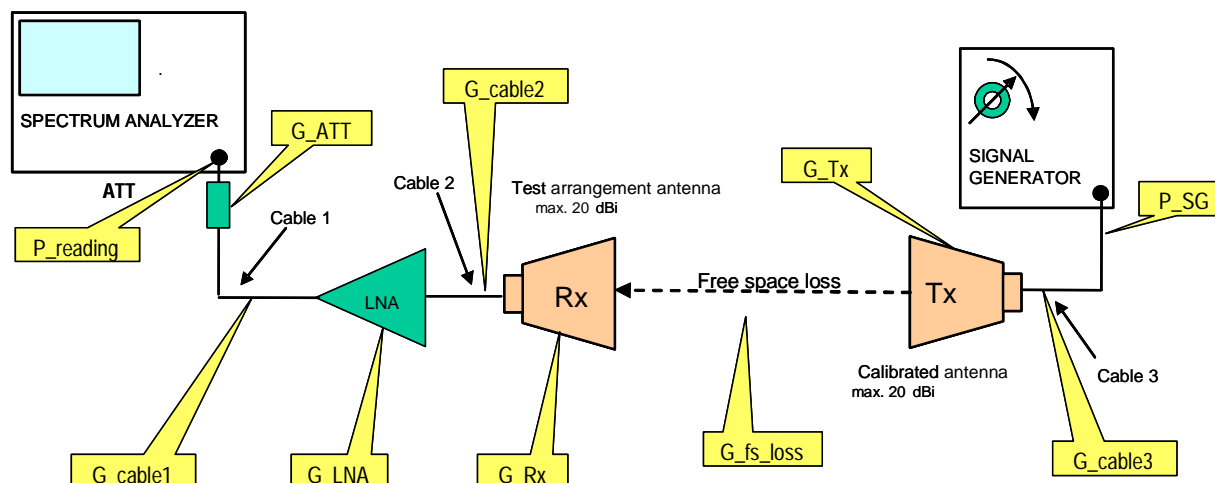

**Figure B.3: Calibration set-up configuration**

The calibration of the test fixture shall be carried out by either the provider or the accredited test laboratory. The results shall be approved by the accredited test laboratory.

It is the responsibility of the tester to obtain enough measurement accuracy. The following description is an example of a proven and accurate calibration method:

- a) Calibrate all instruments using usual calibration routines.
- b) Remove the EUT from the test fixture and replace the EUT by a calibrated antenna. Carefully orientate the calibration antenna in the test fixture towards the test arrangement antenna. The reference plane of the calibration antenna shall coincide with the EUT reference plane. The distance between the calibration antenna and the test arrangement antenna shall be between 0,5 m to 1 m.
- c) Connect a signal generator to the calibrated antenna in the test fixture.
- d) Connect a 10 dB attenuator to the test arrangement antenna to improve the VSWR. If SNR of the test arrangement is low it might be necessary to omit the attenuator.
- e) Connect a power meter to the test arrangement antenna including a 10 dB attenuator, if required, and apply, by means of a signal generator, a frequency and power level to the same as the expected value from the EUT output to the calibration antenna in the test fixture.
- f) Take into account the gain from both the calibration and the test arrangement antenna, the losses from the attenuator and all cables in use and the gain of a LNA, if required.
- g) Note the absolute reading of the power meter.
- h) Replace the power meter with a spectrum analyser. Adjust the frequency and power level of the signal generator to the same as the expected value from the EUT output. Apply this signal to the calibration antenna.
- i) Take into account the gain from both the calibration and the test arrangement antenna, the losses from the attenuator and all cables in use and the gain of a LNA, if required. Instead of an external attenuator the built-in attenuator of the spectrum analyser may be used.

- j) Set the spectrum analyser detector in RMS mode with a RBW and VBW at least as large as the signal generator output signal bandwidth with an appropriate spectrum analyser sweep rate. Note the absolute reading of the spectrum analysers input signal.
- k) The noted absolute power reading of the power meter and the spectrum analyser shall not differ more than the specified uncertainty of the used measurement equipments.
- l) Calculate the total attenuation from the EUT reference plane to the spectrum analyser as follows:
- P\_reading = the absolute power level noted from the power meter/spectrum analyser.
  - G\_Tx = antenna gain of the calibrated antenna in the test fixture.
  - G\_Rx = antenna gain of the test arrangement antenna.
  - G\_ATT = the 10 dB attenuator loss (0 dB, if attenuator not used).
  - G\_cable = the total loss of all cables used in the test setup.
  - G\_LNA = the gain of the low noise amplifier (0 dB, if LNA not used).
  - G\_fs\_loss = the free space loss between the calibrated antenna (Tx) in the test fixture and the test arrangement antenna (Rx).
  - C\_ATT = calculated attenuation of all losses with referenced to the EUT position.
  - P\_abs = the absolute power of the EUT (e.i.r.p.).
  - C\_ATT = G\_fs\_loss - G\_Rx + G\_cable2 - G\_LNA + G\_cable1 + G\_ATT.
  - P\_abs = P\_reading - C\_ATT.

The calibration should be carried out at a minimum of three frequencies within the operating frequency band.

---

## Annex C (normative): Conducted measurements for DAA testing

Conducted measurements may be applied to DAA equipment provided with an antenna connector.

The antenna gain of the dedicated antenna and the losses (including those from impedance matching) over frequencies shall be taken into account to assess the detection threshold levels as given in annexes E to G. These detection thresholds assume a 0 dBi gain receive characteristics.

The Voltage Standing Wave Ratio (VSWR) at the 50  $\Omega$  connector shall not be greater than 1,5: 1 over the frequency range of the measurement.

All cables shall be calibrated over the complete frequency range of measurement.



## Annex D (informative): Measurement antenna and preamplifier specifications

The radiated measurements set-up in annex B specifies the use of a horn antenna and a wide-band, high gain preamplifier above 1 GHz in order to measure the very low radiated power density level from UWB equipment.

Table D.1 gives examples of recommended data and features for the horn antenna and preamplifier to be used for the test set-up.

**Table D.1: Recommended performance data for preamplifier and horn antenna**

<b>Pre-amplifier</b>	
<b>Parameter</b>	<b>Data</b>
Bandwidth	<1 GHz to >15 GHz
Noise figure	< 2 dB
Output at 1 dB compression	> +10 dBm
Gain	> 30 dB (see note)
Gain flatness across band	± 1,5 dB
Phase response	Linear across frequency range
Impulse response overshoot	< 10 %
Impulse response damping ratio	0,3 to 0,5
VSWR in/out across band	2:1
Nominal impedance	50 Ω
<b>Horn antenna</b>	
<b>Parameter</b>	<b>Data</b>
Gain	> 10 dBi (see note)
3 dB bandwidth	<1 GHz to >15 GHz
Nominal impedance	50 Ω
VSWR across band	< 1,5:1
Cross polarization	> 20 dB
Front to back ratio	> 20 dB
Tripod mountable	Yes
Robust precision RF connector	Yes
NOTE:	The combination of preamplifier and horn antenna should give an overall equivalent gain of about 40 dB without overloading the spectrum analyser. The noise floor of the combined equipment should be at least 6 dB below the limits specified in the radiated tests given in the present document.

## Annex E (normative): Radiolocation services in the band 3,1 GHz to 3,4 GHz

**Table E.1: Band 3,1 GHz to 3,4 GHz: Radiolocation systems Detect and avoid parameter set**

Parameter	Symbol	Zone 1	Zone 2
Minimum Initial channel availability Check time	$T_{\text{avail\_time\_min}}$	14 s	
Maximum Detect and Avoid time	$T_{\text{avoid\_max}}$	150 s	
Detection probability		99 % (see note)	
Detection probability in Continuous detection operation during UWB radio device operation		97 % (see note)	
Signal detection threshold (Peak Detector)	$D_{\text{thresh}}$	$D_{\text{thresh\_1}} = -38 \text{ dBm}$	
Avoidance Level (UWB maximum mean Tx Power density)		-70 dBm/MHz	-41,3 dBm/MHz
Default Avoidance Bandwidth		3,1 GHz to 3,4 GHz (300 MHz)	
Possible Avoidance Options		All	
NOTE:	5 consecutive tests shall be performed for each radar signal. If the radar signal was detected all 5 times the UWB DAA radio device will have passed the test. If the radar signal was not detected one time, the test shall be repeated another 10 times with the same radar signal. If the radar signal was detected all 10 times the UWB DAA radio device will have passed the test.		

### Additional requirement for operation in the band 3,1 GHz to 4,8 GHz:

UWB DAA radio devices shall be capable of selecting an operating channel anywhere within the band 3,1 GHz to 4,8 GHz.

## Annex F (normative): Broadband wireless access services in the band 3,4 GHz to 3,8 GHz

**Table F.1: BWA Detect and avoid parameter set**

Parameter		Zone 1	Zone 2	Zone 3
Minimum Initial channel availability Check time	$T_{avail\_time\_min}$	5,1 s		
Detection Probability for initial detect operation after UWB radio device power on		99 % (see note)		
Signal detection threshold (UL)	$D_{thresh(UL)}$	$D_{thresh\_1} = -38$ dBm	$D_{thresh\_2} = -61$ dBm	
Avoidance Level (UWB Maximum mean Tx Power density)		-80 dBm/MHz in the frequency range from 3,4 GHz to 3,8 GHz and	-65 dBm/MHz	-41,3 dBm/MHz
Default Avoidance Bandwidth		3,4 GHz to 3,6 GHz, 3,6 GHz to 3,8 GHz (see note 2)		
Possible Avoidance Options		All		
NOTE 1: 5 consecutive tests shall be performed for each BWA signal. If the BWA signal was detected all 5 times the UWB DAA radio device will have passed the test. If the BWA signal was not detected one time, the test shall be repeated another 10 times with the same BWA signal. If the BWA signal was detected all 10 times the UWB DAA radio device will have passed the test.				
NOTE 2: The phrase " <i>default avoidance bandwidth</i> " means that if the victim was detected in the range 3,4 GHz to 3,6 GHz the " <i>complete default avoidance bandwidth</i> " is 3,4 GHz to 3,6 GHz and if the victim was detected in the range 3,6 GHz to 3,8 GHz the " <i>complete default avoidance bandwidth</i> " is 3,6 GHz to 3,8 GHz.				

NOTE: Detection mechanism needs to be validated to protect existing operation of victim stations of radio services such as BWA terminals in the band 3,4 GHz to 3,8 GHz.

**Table F.2: BWA Detect and avoid timings**

BWA system / mode	Maximum Detect and Avoid Time, $T_{avoid\_max}$	Detection Probability (for continuous detect operation) (see note 2)
VoIP	2 s	95 %
Web surfing	15 s	95 %
Sleep mode (see note 1)	60 s	95 %
Multimedia broadcasting	15 s	95 %
NOTE 1: For the purposes of testing, the sleep mode is covered by the multimedia broadcasting mode.		
NOTE 2: 5 consecutive tests shall be performed for each BWA signal. If the BWA signal was detected all 5 times the UWB DAA radio device will have passed the test. If the BWA signal was not detected one time, the test shall be repeated another 10 times with the same BWA signal. If the BWA signal was detected all 10 times the UWB DAA radio device will have passed the test.		

### Additional requirement for operation in the band 3,1 GHz to 4,8 GHz:

UWB DAA radio devices shall be capable of selecting an operating channel anywhere within the band 3,1 GHz to 4,8 GHz.

## Annex G (normative): Radiolocation services in the band 8,5 GHz to 9,0 GHz

**Table G.1: Band 8,5 GHz to 9,0 GHz: Radiolocation systems Detect and avoid parameter set**

Parameter		Zone 1	Zone 2
Minimum Initial channel availability Check time	$T_{\text{avail\_time\_min}}$	14 s	
Maximum Detect and Avoid time	$T_{\text{avoid\_max}}$	150 s	
Detection probability		99 % (see note)	
Detection probability in Continuous detection operation during UWB radio device operation		97 % (see note)	
Signal detection threshold (Peak Detector)	$D_{\text{thresh}}$	$D_{\text{thresh\_1}} = -61$ dBm	
Avoidance Level (UWB maximum mean Tx Power density)		-65 dBm/MHz	-41,3 dBm/MHz
Default Avoidance Bandwidth		8,5 GHz to 9,0 GHz (500 MHz)	
Possible Avoidance Options		All	
NOTE: 5 consecutive tests shall be performed for each radar signal. If the radar signal was detected all 5 times the UWB DAA radio device will have passed the test. If the radar signal was not detected one time, the test shall be repeated another 10 times with the same radar signal. If the radar signal was detected all 10 times the UWB DAA radio device will have passed the test.			

## Annex H (informative): Calculation of peak limit for 3 MHz measurement bandwidth

For impulsive modulation schemes the present document specifies a fixed maximum limit for average power in a 1 MHz bandwidth. The relationship between the PRF and the peak power to average power ratio is given in Figure H.1.

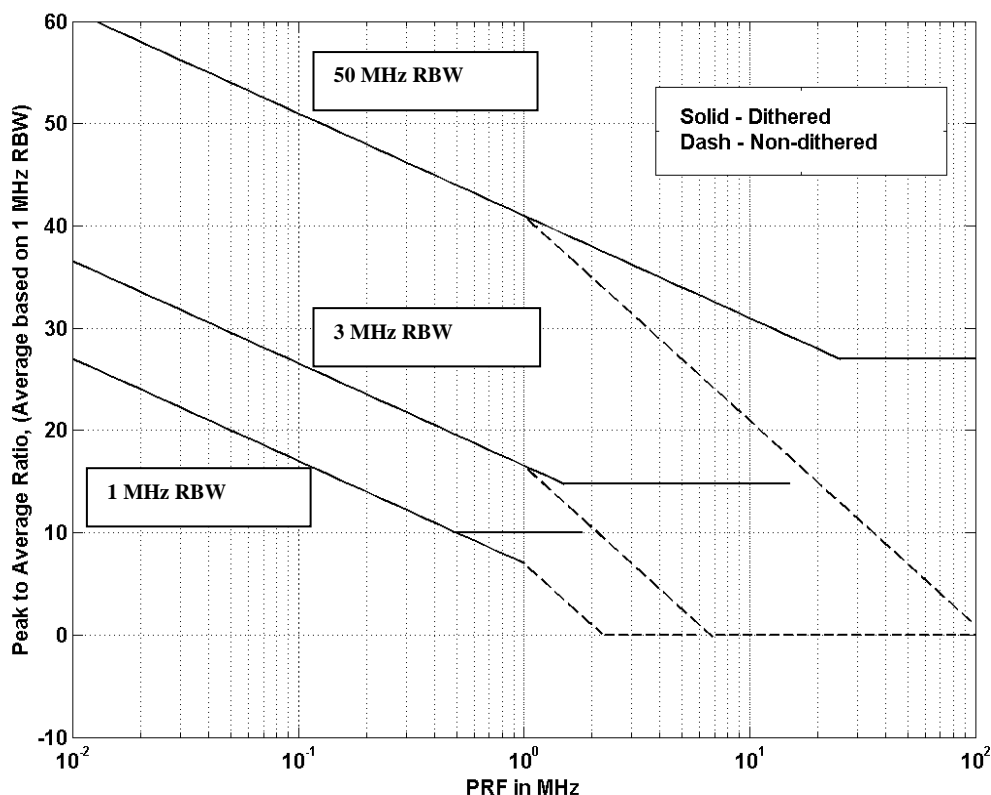

**Figure H.1: Peak to average power versus PRF**

For a noise like signal (e.g. dithered pulses) the roll-off rate is -10 dB/decade with a break point at half of the resolution bandwidth. Consequently, the breakpoints for 50 MHz, 3 MHz and 1 MHz resolution bandwidths are 25 MHz, 1,5 MHz and 0,5 MHz respectively.

As a peak measurement using a 50 MHz resolution bandwidth is difficult to impossible to conduct, the peak power is measured with a 3 MHz resolution bandwidth.

The curve for 3 MHz resolution bandwidth is  $20\log(\text{BW } 50 \text{ MHz}/\text{BW } 3 \text{ MHz}) = 24,4 \text{ dB}$  lower than for a 50 MHz resolution bandwidth. A peak limit of 0 dBm at 50 MHz will consequently be reduced correspondingly by 24,4 dB to -24,4 dBm.

As the dithered limit values are almost identical below and above 1 MHz PRF (within  $\pm 1 \text{ dB}$ ). For a 3 MHz measuring bandwidth the peak limit is adjusted to -25 dBm within the entire range for PRF.

The resulting Peak limit is shown in Figure H.2.

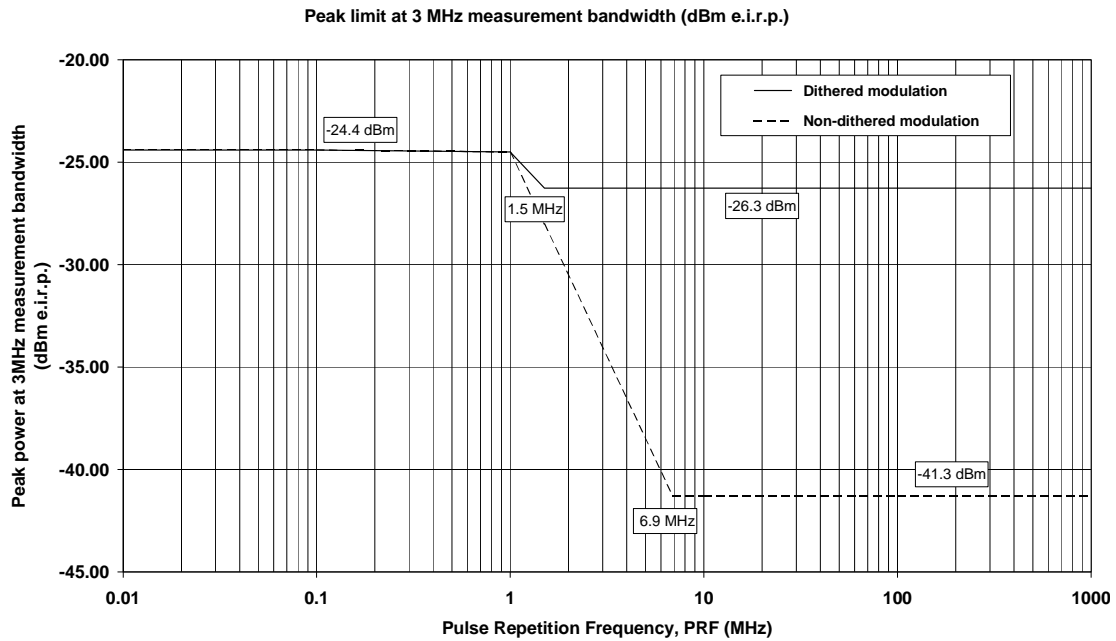

**Figure H.2: Peak power limit in a 3 MHz bandwidth**

Non-dithered modulation does not have the characteristics of a noise like spread spectrum but contains instead higher-level non-spread spectrum lines. To protect against these non-dithered spectrum lines the Peak limit is reduced further for PRF frequencies above 1 MHz by an additional -20 dB/decade roll-off until the peak to average ratio is zero. The resulting peak limit at 3 MHz is identical to the average limit in 1 MHz bandwidth for PRF above approximately 6,9 MHz.

---

## Annex I (normative): ICS Proforma for DAA radio device

### I.1 Identification of the protocol

This ICS proforma applies to the DAA specifications listed in the normative references clause of the present document.

---

### I.2 ICS proforma tables

#### I.2.1 Avoidance Modes

These are detailed in Table H.1.

**Table H.1: Avoidance Modes for Radar and BWA operation**

Item	Avoidance Mode	Ref Clauses	Support (Y/N)	Values supported
1	Does the UWB radio device support a victim service ID?	[5] clause 5.2.2		
2	Does the UWB radio device support optional avoidance mechanisms?	[5] clause 6		

---

## Annex J (informative): Bibliography

- CEPT ECC/DEC/(06)12 of 1 December 2006 amended Cordoba, 31 October 2008 on supplementary regulatory provisions to Decision ECC/DEC/(06)04 for UWB devices using mitigation techniques.
- CENELEC EN 55022 (2006): "Information technology equipment. Radio disturbance characteristics. Limits and methods of measurement".
- Ketterling, H-P: "Verification of the performance of fully and semi-anechoic chambers for radiation measurements and susceptibility/immunity testing", 1991, Leatherhead/Surrey.
- ECC TG3#18-18R0: "Flexible DAA mechanism based on "isolation criteria" between victim service and UWB devices", ECC TG3 Meeting 18, Mainz, March 2007.
- ICT project WALTER, Wireless alliances for testing experiment and research": <http://www.walter-uwband.eu/>.
- ETSI TR 102 070-2: "Electromagnetic compatibility and Radio spectrum Matters (ERM); Guide to the application of harmonized standards to multi-radio and combined radio and non-radio equipment; Part 2: Effective use of the radio frequency spectrum".
- 2008/411/EC: "Commission decision of 21 May 2008 on the harmonisation of the 3 400-3 800 MHz frequency band for terrestrial systems capable of providing electronic communications services in the Community".
- ETSI EN 301 489-33 (V1.1.1): "Electromagnetic compatibility and Radio spectrum Matters (ERM); ElectroMagnetic Compatibility (EMC) standard for radio equipment and services; Part 33: Specific conditions for Ultra Wide Band (UWB) communications devices".



---

## Annex K (informative): The EN title in the official languages

The enlargement of the European Union (EU) resulted in a requirement from the EU for a larger number of languages for the translation of the titles of Harmonized Standards and mandated ENs that are to be listed in the Official Journal to support the implementation of this legislation.

For this reason the title translation concerning the present document can be consulted via the [e-approval](#) application.

---

## History

<b>Document history</b>		
V1.1.1	February 2008	Publication
V1.2.1	December 2009	Public Enquiry PE 20100413: 2009-12-14 to 2010-04-13