

# ETSI EN 302 062 V1.1.1 (2003-01)

---

*European Standard (Telecommunications series)*

**Fixed Radio Systems;  
Point-to-point equipment;  
High capacity digital radio relay systems  
carrying STM-4, 4 × STM-1 or 2 × STM-1 signals  
in bands with 55/56 MHz channel spacing**

---



---

Reference

DEN/TM-04105

---

Keywords

DFRS, digital, DRRS, point-to-point, radio, SDH,  
transmission

**ETSI**

650 Route des Lucioles  
F-06921 Sophia Antipolis Cedex - FRANCE

Tel.: +33 4 92 94 42 00 Fax: +33 4 93 65 47 16

Siret N° 348 623 562 00017 - NAF 742 C  
Association à but non lucratif enregistrée à la  
Sous-Préfecture de Grasse (06) N° 7803/88

---

**Important notice**

Individual copies of the present document can be downloaded from:

<http://www.etsi.org>

The present document may be made available in more than one electronic version or in print. In any case of existing or perceived difference in contents between such versions, the reference version is the Portable Document Format (PDF). In case of dispute, the reference shall be the printing on ETSI printers of the PDF version kept on a specific network drive within ETSI Secretariat.

Users of the present document should be aware that the document may be subject to revision or change of status. Information on the current status of this and other ETSI documents is available at

<http://portal.etsi.org/tb/status/status.asp>

If you find errors in the present document, send your comment to:

[editor@etsi.org](mailto:editor@etsi.org)

---

**Copyright Notification**

No part may be reproduced except as authorized by written permission.  
The copyright and the foregoing restriction extend to reproduction in all media.

© European Telecommunications Standards Institute 2003.  
All rights reserved.

**DECT™**, **PLUGTESTS™** and **UMTS™** are Trade Marks of ETSI registered for the benefit of its Members.  
**TIPHON™** and the **TIPHON logo** are Trade Marks currently being registered by ETSI for the benefit of its Members.  
**3GPP™** is a Trade Mark of ETSI registered for the benefit of its Members and of the 3GPP Organizational Partners.

# Contents

Intellectual Property Rights .....	5
Foreword.....	5
1 Scope .....	6
2 References .....	7
3 Symbols and abbreviations.....	10
3.1 Symbols.....	10
3.2 Abbreviations .....	10
4 General characteristics .....	11
4.1 Frequency bands and channel arrangements .....	11
4.1.1 Channel arrangements.....	11
4.1.2 Channel spacing for systems operating on the same route.....	12
4.2 Compatibility requirements between systems .....	12
4.3 Performance and availability requirements .....	12
4.4 Environmental profile.....	12
4.4.1 Equipment within weather protected locations (indoor locations).....	13
4.4.2 Equipment for non-weather protected locations (outdoor locations) .....	13
4.5 Power supply .....	13
4.6 Electromagnetic compatibility.....	13
4.7 System block diagrams.....	13
4.8 Telecommunications Management Network (TMN) interface.....	14
4.9 Branching/feeder/antenna characteristics .....	14
4.9.1 Antenna radiation patterns .....	14
4.9.2 Antenna Cross-Polar Discrimination (XPD).....	14
4.9.3 Antenna Inter-Port Isolation (IPI).....	14
4.9.4 Waveguide flanges (or other connectors) .....	14
4.9.5 Return loss .....	15
5 System parameters.....	15
5.1 Transmission capacity .....	15
5.2 Baseband parameters .....	15
5.2.1 SDH baseband interface.....	15
5.3 Transmitter characteristics.....	15
5.3.1 Transmitter power limit .....	15
5.3.2 Transmit power and frequency control .....	16
5.3.2.1 Transmit Power Control (ATPC and RTPC) .....	16
5.3.2.1.1 Automatic Transmit Power Control (ATPC).....	16
5.3.2.1.2 Remote Transmit Power Control (RTPC) .....	17
5.3.2.2 Remote Frequency Control (RFC) .....	17
5.3.3 Transmitter output power tolerance .....	17
5.3.4 Transmit Local Oscillator (LO) frequency arrangements .....	17
5.3.5 RF spectrum mask .....	18
5.3.6 Discrete CW components exceeding the spectrum mask limit .....	20
5.3.6.1 Discrete CW components at the symbol rate .....	20
5.3.6.2 Other discrete CW components exceeding the spectrum mask limit .....	20
5.3.7 Spurious emissions .....	21
5.3.7.1 Spurious emissions - external.....	21
5.3.7.2 Spurious emissions - internal .....	21
5.3.8 Radio frequency tolerance .....	21
5.4 Receiver characteristics .....	21
5.4.1 Input level range .....	21
5.4.2 Receiver local oscillator frequency arrangements .....	21
5.4.3 Spurious emissions .....	21
5.5 System performance without diversity .....	22
5.5.1 BER as a function of Receiver input Signal Level (RSL).....	22

5.5.2	Equipment Residual BER .....	22
5.5.3	Interference sensitivity.....	22
5.5.3.1	Co-channel interference sensitivity .....	23
5.5.3.2	Adjacent channel Interference.....	23
5.5.3.3	CW Spurious Interference.....	23
5.5.4	Cross-Polar Interference Sensitivity for CCDP with XPIC operation .....	23
5.5.4.1	Co-channel "internal" interference sensitivity in flat fading conditions.....	24
5.5.4.2	Co-channel "internal" interference sensitivity in dispersive fading conditions.....	24
5.5.5	Distortion sensitivity.....	24
5.6	System characteristics with diversity .....	24
<b>Annex A (informative): Additional information.....</b>		<b>25</b>
A.1	Cross-Polar Discrimination (XPD) of the antenna.....	25
A.2	Measurement test set for XPI characteristics .....	25
A.3	Automatic Transmit Power Control (ATPC) .....	26
A.4	RBER .....	27
A.5	Co-channel and adjacent channel interference .....	28
<b>Annex B (normative): Output Power Tolerance and RBER.....</b>		<b>30</b>
<b>Annex C (normative): BER measurement in a multi-interface, multi-carrier system .....</b>		<b>31</b>
History .....		32

---

## Intellectual Property Rights

IPRs essential or potentially essential to the present document may have been declared to ETSI. The information pertaining to these essential IPRs, if any, is publicly available for **ETSI members and non-members**, and can be found in ETSI SR 000 314: "*Intellectual Property Rights (IPRs); Essential, or potentially Essential, IPRs notified to ETSI in respect of ETSI standards*", which is available from the ETSI Secretariat. Latest updates are available on the ETSI Web server (<http://webapp.etsi.org/IPR/home.asp>).

All published ETSI deliverables shall include information which directs the reader to the above source of information.

---

## Foreword

This European Standard (Telecommunications series) has been produced by ETSI Technical Committee Transmission and Multiplexing (TM).

<b>National transposition dates</b>	
Date of adoption of this EN:	27 December 2002
Date of latest announcement of this EN (doa):	31 March 2003
Date of latest publication of new National Standard or endorsement of this EN (dop/e):	30 September 2003
Date of withdrawal of any conflicting National Standard (dow):	30 September 2003

# 1 Scope

The present document specifies the minimum performance parameters for terrestrial digital fixed service radio communications equipments operating in the 15 GHz to 38 GHz frequency band intended to be used for point-to-point connections in local and regional networks at data rates between  $2 \times \text{STM-1}$  (transported by one carrier) and  $4 \times \text{STM-1}$  or  $\text{STM-4}$  (transported by two  $2 \times \text{STM-1}$  carriers).

Harmonized channel spacings of 56 MHz are not available in frequency bands below 15 GHz at the drafting date of the present document. However, the present document can be considered as a guideline where national frequency plans allow the use of 55/56 MHz channel spacing in other frequency bands, or where an allocation of two contiguous 28 MHz channels is possible.

The maximum transmission rate in a given bandwidth depends on system spectral efficiency, a single equipment class is defined:

Class 5: equipment spectral efficiency based on typically 128-states modulation scheme (e.g. 128-QAM, or equivalent).

However, for addressing different market requirements, the systems are further subdivided in two grades:

- a) Adjacent Channel Alternate Polarization (ACAP as class 5a).
- b) Adjacent Channel Co-Polarization (ACCP or CCDP as class 5b).

The above classes are indicative only and do not imply any constraint to the actual modulation format, provided that all the requirements in the present document are met.

Examples of the spectrum usage are given in figure 1.

The  $4 \times \text{STM-1}$  or  $\text{STM-4}$  connection is achieved by two  $2 \times \text{STM-1}$  carriers. The two carriers can be arranged in three configurations:

- a) Adjacent Channel Alternate Polarization for which ACAP, class 5a is applicable.
- b) Adjacent Channel Co-polarization for which ACCP, class 5b is applicable.
- c) Co-Channel Dual Polarization for which CCDP, class 5b is applicable. For this configuration, XPIC may be used.

Examples of the three spectrum usage of a  $4 \times \text{STM-1}$  or  $\text{STM-4}$  system are given in figures 1a, 1b, and 1c.

A  $2 \times \text{STM-1}$  system is achieved by using one single carrier in 55/56 MHz from any of the configurations in figure 1; the system shall comply with the relevant spectrum efficiency classes (5a or 5b).

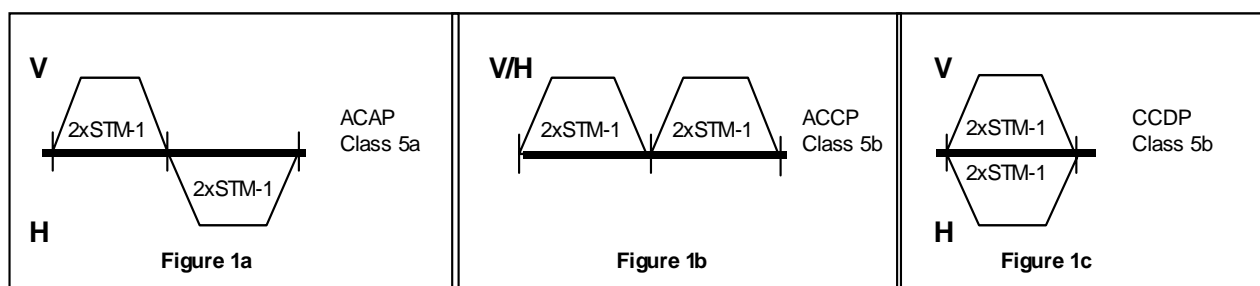

NOTE 1: For practical reasons, for configurations in figure 1a and 1b, it may be required to separate the two carriers due to spectrum availability. However, in all cases the two carriers system is required to be capable of operating in at least one of the configurations shown above.

NOTE 2: Due to the internal functionality of the cross-polar interference canceller (XPIC) equipment on both polarization of the same channel is considered to form a single CCDP system according to figure 1c.

**Figure 1: System configurations**

The present document, defines the parameters for  $2 \times$  STM-1 (311 Mbit/s) carriers. The performance of a  $4 \times$  STM-1 or STM-4 system will be directly implicated from this definition, according to the spectrum efficiency classes 5a and 5b.

The parameters to be specified fall into two categories:

- a) Parameters that are required to provide compatibility between channels from different sources of equipment on the same route, connected to separate antennas.
- b) Parameters defining the transmission quality of the proposed system.

The present document does not contain aspects related to test procedures and test conditions however they are to be found in EN 301 126-1 [9].

Safety aspects are outside the mandate of ETSI and they will not be considered in the present document. However compliance to EN 60950 [47] will be required to comply with Directive 1999/5/EC (R&TTE Directive) [8].

Technical background for most of the parameters and requirements referred in the present document may be found in TR 101 036-1 [45].

## 2 References

The following documents contain provisions which, through reference in this text, constitute provisions of the present document.

- References are either specific (identified by date of publication and/or edition number or version number) or non-specific.
- For a specific reference, subsequent revisions do not apply.
- For a non-specific reference, the latest version applies.

Referenced documents which are not found to be publicly available in the expected location might be found at <http://docbox.etsi.org/Reference/>.

NOTE: In the case of undated references, the time frame of application and new certification procedures for new releases of these normative references next to the date of the first public enquiry of the present document, or to the first certification of the equipment shall be agreed between the supplier and the regulatory authority. These new certification procedures will cover in any case only the parameters subject to changes from the on going release during the previous certification.

- [1] CEPT/ERC/T/R 13-02: "Preferred channel arrangements for fixed services in the range 22.0-29.5 GHz".
- [2] CEPT/ERC/T/R 12-01: "Harmonized radio frequency channel arrangements for analogue and digital terrestrial fixed systems operating in the band 37-39.5 GHz".
- [3] CEPT/ERC/REC 12-07: "Harmonised radio frequency channel arrangements for digital terrestrial fixed systems operating in the band 14.5 - 14.62 GHz paired with 15.23 - 15.35 GHz".
- [4] CEPT/ERC/REC 12-03: "Harmonised radio frequency channel arrangements for digital terrestrial fixed systems operating in the band 17.7 GHz to 19.7 GHz".
- [5] CEPT/ERC/REC 01-02: "Preferred channel arrangement for digital fixed service systems operating in the frequency band 31.8 - 33.4 GHz".
- [6] CEPT/ERC/REC 74-01: "Spurious emissions".
- [7] CEPT/ERC/DEC(00)07 of 19 October 2000 on the shared use of the band 17.7 - 19.7 GHz by the fixed service and Earth stations of the fixed-satellite service (space-to-Earth).
- [8] Directive 1999/5/EC of the European Parliament and of the Council of 9 March 1999 on radio equipment and telecommunications terminal equipment and the mutual recognition of their conformity (R&TTE Directive).

- [9] ETSI EN 301 126-1: "Fixed Radio Systems; Conformance testing; Part 1: Point-to-point equipment - Definitions, general requirements and test procedures".
- [10] ETSI EN 300 833: "Fixed Radio Systems; Point-to-point Antennas; Antennas for point-to-point fixed radio systems operating in the frequency band 3 GHz to 60 GHz".
- [11] ETSI EN 300 019: "Environmental Engineering (EE); Environmental conditions and environmental tests for telecommunications equipment".
- [12] ETSI ETS 300 132-1: "Equipment Engineering (EE); Power supply interface at the input to telecommunications equipment; Part 1: Operated by alternating current (ac) derived from direct current (dc) sources".
- [13] ETSI EN 300 132-2: "Environmental Engineering (EE); Power supply interface at the input to telecommunications equipment; Part 2: Operated by direct current (dc)".
- [14] ETSI EN 300 645: "Telecommunications Management Network (TMN); Synchronous Digital Hierarchy (SDH) radio relay equipment; Information model for use on Q interfaces".
- [15] ETSI EN 301 489 (parts 1 and 4): "Electromagnetic compatibility and Radio spectrum Matters (ERM); ElectroMagnetic Compatibility (EMC) standard for radio equipment and services".
- [16] ETSI ETS 300 635: "Transmission and Multiplexing (TM); Synchronous Digital Hierarchy (SDH); Radio specific functional blocks for transmission of M x STM-N".
- [17] ITU-R Recommendation F.595: "Radio-frequency channel arrangements for radio-relay systems operating in the 18 GHz frequency band".
- [18] ITU-R Recommendation F.636: "Radio-frequency channel arrangements for radio-relay systems operating in the 15 GHz band".
- [19] ITU-R Recommendation F.637: "Radio-frequency channel arrangements for fixed wireless systems operating in the 23 GHz band".
- [20] ITU-R Recommendation F.748: "Radio-frequency arrangements for systems of the fixed service operating in the 25, 26 and 28 GHz bands".
- [21] ITU-R Recommendation F.749: "Radio-frequency channel arrangements for radio-relay systems in the 38 GHz band".
- [22] ITU-R Recommendation F.750: "Architectures and functional aspects of radio-relay systems for synchronous digital hierarchy (SDH)-based network".
- [23] ITU-R Recommendation F.751: "Transmission characteristics and performance requirements of radio-relay systems for SDH-based networks".
- [24] ITU-R Recommendation F.752: "Diversity techniques for radio-relay systems".
- [25] ITU-R Recommendation F.1093: "Effects of multipath propagation on the design and operation of line-of-sight digital radio-relay systems".
- [26] ITU-R Recommendation F.1101: "Characteristics of digital fixed wireless systems below about 17 GHz".
- [27] ITU-R Recommendation F.1102: "Characteristics of fixed wireless systems operating in frequency bands above about 17 GHz".
- [28] ITU-R Recommendation F.1191: "Bandwidths and unwanted emissions of digital fixed service systems".
- [29] ITU-R Recommendation F.1397: "Error performance objectives for real digital radio links used in the international portion of a 27 500 km hypothetical reference path at or above the primary rate".
- [30] ITU-R Recommendation F.1491: "Error performance objectives for real digital radio links used in the national portion of a 27 500 km hypothetical reference path at or above the primary rate".



- [31] ITU-R Recommendation F.1492: "Availability objectives for real digital radio-relay links forming part of international portion constant bit rate digital path at or above the primary rate".
- [32] ITU-R Recommendation F.1493: "Availability objectives for real digital radio-relay links forming part of national portion constant bit rate digital path at or above the primary rate".
- [33] ITU-R Recommendation P.530: "Propagation data and prediction methods required for the design of terrestrial line-of-sight systems".
- [34] ITU-T Recommendation G.703: "Physical/electrical characteristics of hierarchical digital interfaces".
- [35] ITU-T Recommendation G.707: "Network node interface for the synchronous digital hierarchy (SDH)".
- [36] ITU-T Recommendation G.773: "Protocol suites for Q-interfaces for management of transmission systems".
- [37] ITU-T Recommendation G.783: "Characteristics of synchronous digital hierarchy (SDH) equipment functional blocks".
- [38] ITU-T Recommendation G.784: "Synchronous digital hierarchy (SDH) management".
- [39] ITU-T Recommendation G.826: "Error performance parameters and objectives for international, constant bit rate digital paths at or above the primary rate".
- [40] ITU-T Recommendation G.828: "Error performance parameters and objectives for international, constant bit rate synchronous digital paths".
- [41] ITU-T Recommendation G.829: "Error performance events for SDH Multiplex and regenerator sections".
- [42] ITU-T Recommendation G.957: "Optical interfaces for equipments and systems relating to the synchronous digital hierarchy".
- [43] ITU-T Recommendation O.181: "Equipment to assess error performance on STM-N interfaces".
- [44] ETSI TR 101 035 (V1.1.3): "Transmission and Multiplexing (TM); Synchronous Digital Hierarchy (SDH) aspects regarding Digital Radio Relay Systems (DRRS)".
- [45] ETSI TR 101 036-1 (V1.3.1): "Fixed Radio Systems; Generic wordings for standards on DFRS (Digital Fixed Radio Systems) characteristics; Part 1: General aspects and point-to-point equipment parameters".
- [46] IEC 60154-2: "Flanges for waveguides. Part 2: Relevant specifications for flanges for ordinary rectangular waveguides".
- [47] EN 60950: "Information technology equipment - Safety".

## 3 Symbols and abbreviations

### 3.1 Symbols

For the purposes of the present document, the following symbols apply:

dB	decibel
dBm	decibel relative to 1 mW
GHz	GigaHertz
kHz	kiloHertz
Mbit/s	Mega-bits per second
MHz	MegaHertz
mW	milliWatt
ns	nanosecond
ppm	parts per million

### 3.2 Abbreviations

For the purposes of the present document, the following abbreviations apply:

ac	alternating current
ACAP	Adjacent Channel Alternate Polarization
ACCP	Adjacent Channel Co-Polarization
ATPC	Automatic Transmit Power Control
BB	Base Band
BWe	evaluation BandWidth (resolution bandwidth in which spectrum components are measured)
C/I	Carrier to Interference ratio
CCDP	Co-Channel Dual Polarization
CEPT	Conference of European Posts and Telecommunications
CMI	Coded Mark Inversion
CSmin	minimum practical Channel Separation (for a given radio-frequency channel arrangement)
CW	Continuous Wave
dc	direct current
DEM	DEModulator
DRRS	Digital Radio Relay Systems
EIRP	Equivalent Isotropically Radiated Power
EMC	ElectroMagnetic Compatibility
ERC	European Radiocommunications Committee
ESR	Errored Second Ratio
F <sub>c</sub>	cut-off Frequency
IEC	International Electrotechnical Committee
IF	Intermediate Frequency
IPI	Inter-Port Isolation
ITU-R	International Telecommunication Union-Radiocommunications standardization sector
ITU-T	International Telecommunication Union-Telecommunications standardization sector
LO	Local Oscillator
MOD	MODulator
PRBS	Pseudo Random Binary Sequence
QAM	Quadrature Amplitude Modulation
RBER	Residual BER
RF	Radio Frequency
RFC	Remote Frequency Control
RSL	Receive Signal Level
RTPC	Remote Transmit Power Control
R <sub>x</sub>	Receiver
SDH	Synchronous Digital Hierarchy
SOH	Section OverHead
STM-N	Synchronous Transport Module, level N
TM	ETSI TC-Transmission and Multiplexing

TMN	Telecommunications Management Network
Tx	Transmitter
XPD	Cross-Polar Discrimination
XPIC	Cross-Polar Interference Canceller

---

## 4 General characteristics

### 4.1 Frequency bands and channel arrangements

#### 4.1.1 Channel arrangements

The frequency range shall be derived from the CEPT Recommendations relevant for the frequency band.

##### **15 GHz**

The systems are required to operate in the 14,5 GHz to 14,62 GHz paired with 15,23 GHz to 15,35 GHz, with a channel spacing of 56 MHz. The equipment shall be capable of operating to the channel plans specified in CEPT/ERC/REC 12-07 [3] or in ITU-R Recommendation F.636 [18].

##### **18 GHz**

The systems are required to operate in the 17,7 GHz to 19,7 GHz frequency band, with a channel spacing of 55 MHz. The equipment shall be capable of operating to the channel plans specified in CEPT/ERC/REC 12-03 [4] or ITU-R Recommendation F.595 [17].

##### **23 GHz**

The frequency range shall be 22,0 GHz to 22,6 GHz paired with 23 GHz to 23,6 GHz. The channel arrangements shall be in accordance with CEPT/REC/T/R 13-02 [1].

NOTE: In a transition period for the adoption of CEPT/REC/T/R 13-02 [1], different plans, derived by ITU-R Recommendation F.637 [19], may be required on national basis.

##### **26 GHz**

The frequency range shall be 24,50 GHz to 29,50 GHz. The channel arrangements shall be in accordance with CEPT/ERC/T/R 13-02 [1] or ITU-R Recommendation F.748 [20].

##### **32 GHz**

The frequency range shall be 31,8 GHz to 33,4 GHz. The channel arrangements shall be in accordance with CEPT/ERC/REC 01-02 [5].

##### **38 GHz**

The frequency range shall be 37,0 GHz to 39,5 GHz. The channel arrangements shall be in accordance with CEPT/ERC/T/R 12-01 [2] or ITU-R Recommendation F.749 [21].

## 4.1.2 Channel spacing for systems operating on the same route

The present document covers systems with one  $2 \times$  STM-1 carrier, or two  $2 \times$  STM-1 carriers that are combined to STM-4 or  $4 \times$  STM-1 signals. The channel spacing for these systems is 55/56 MHz.

System bit rates and their relevant occupied spectrum are reported in table 1 (for the precise payload bit rates, see clause 5.1).

**Table 1: Digital systems channel spacings occupied spectrum channel spacings for various bit rates**

Payload Bit Rate at reference point Z	2 x 155 Mbit/s		4 x 155 Mbit/s	
Equipment class	5a	5b	5a	5b
Channel spacings [MHz]	56 (figure 1a)	56 (fig. 1b or 1c)	112 or 2 x 56 (figure 1a)	56 (figure 1c)/ 112 or 2 x 56 (figure 1a or 1b)

NOTE: For 18 GHz, the occupied spectrum is 55 MHz or 110 MHz.

For regulatory purposes in national procedures for licensing radio equipment according to the present document, the above system types shall be identified by the "system type codes" reported in annex C.

## 4.2 Compatibility requirements between systems

The compatibility requirements between systems are as follows:

- there shall be no requirement to operate transmitting equipment from one manufacturer with receiving equipment from another;
- there shall not be a requirement to multiplex different manufacturers' equipment on the same antenna.

## 4.3 Performance and availability requirements

Equipment shall be designed in order to meet network performance and availability requirements foreseen by ITU-T Recommendations G.826 [39] and G.828 [40].

The events for SDH multiplex and regenerator sections should be measured according to ITU-T Recommendation G.829 [41].

The performance and availability objectives for any overall radio connection, used in the international or national portion of the digital path, have to be based on the criteria defined in ITU-R Recommendations F.1397 [29] and F.1492 [31], for international portion, F.1491 [30] and F.1493 [32], for the national portion.

The implication of the link design on the performance is recognized and the general design criteria reported in ITU-R Recommendations F.752 [24], F.1093 [25], F.1101 [26] and F.1102 [27] are to be applied according the foreseen propagation scenario reported in ITU-R Recommendation P.530 [33].

## 4.4 Environmental profile

The equipment shall be required to meet the environmental conditions set out in the multipart standard EN 300 019 [11], which defines weather protected and non-weather protected locations, classes and test severity.

The equipment shall comply with all the requirements of the present document at all times when operating within the boundary limits of the operational environmental profile of the equipment.

The environmental profile of the equipment shall be declared by the manufacturer.

The fulfilment of EN 300 019 [11] environmental profiles is voluntary and not essential from the point of view of R&TTE Directive [8]; for this purpose any operational environmental profile, as declared by the manufacturer, shall be used.

Any test, carried out to generate the test report and/or declaration of conformity, required to fulfil any conformity assessment procedure foreseen by the R&TTE Directive [8] for radio equipment, shall be carried-out with the same principles and procedures, for reference and extreme conditions, reported in clause 4.4 of EN 301 126-1 [9]. The requirement for test at reference or extreme conditions is reported in the relevant clause of the present document according to the principles for similar requirements in EN 301 126-1 [9].

#### 4.4.1 Equipment within weather protected locations (indoor locations)

Equipment intended for operation within temperature controlled locations or partially temperature controlled locations shall meet the requirements of EN 300 019 [11] classes 3.1 and 3.2 respectively.

Optionally, the more stringent requirements of EN 300 019 [11] classes 3.3 (non-temperature controlled locations), 3.4 (sites with heat trap) and 3.5 (sheltered locations) may be applied.

#### 4.4.2 Equipment for non-weather protected locations (outdoor locations)

Equipment intended for operation within non-weather-protected locations shall meet the requirements of EN 300 019 [11], class 4.1 or 4.1E.

Class 4.1 applies to many European countries and class 4.1E applies to all European countries.

### 4.5 Power supply

The power supply interface shall be in accordance with the characteristics of one or more of the secondary voltages foreseen in ETS 300 132-1 [12] and EN 300 132-2 [13].

NOTE: Some applications may require secondary voltages that are not covered by ETS 300 132-1 [12] and EN 300 132-2 [13].

### 4.6 Electromagnetic compatibility

Equipment shall operate under the conditions specified in EN 301 489 (parts 1 and 4) [15].

### 4.7 System block diagrams

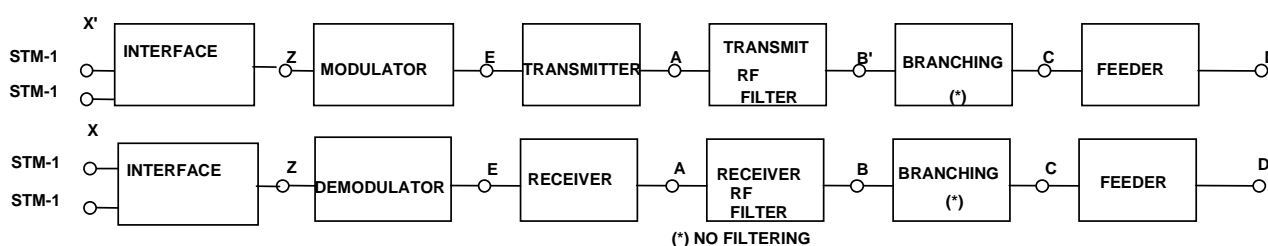

NOTE 1: For the purpose of defining the measurement points, the branching network does not include a hybrid.

NOTE 2: The points shown above are reference points only; points C and C', D and D' in general coincide.

NOTE 3: Points B and C, B' and C' may coincide when simple duplexer is used.

**Figure 2: 2 x STM-1 System block diagram**

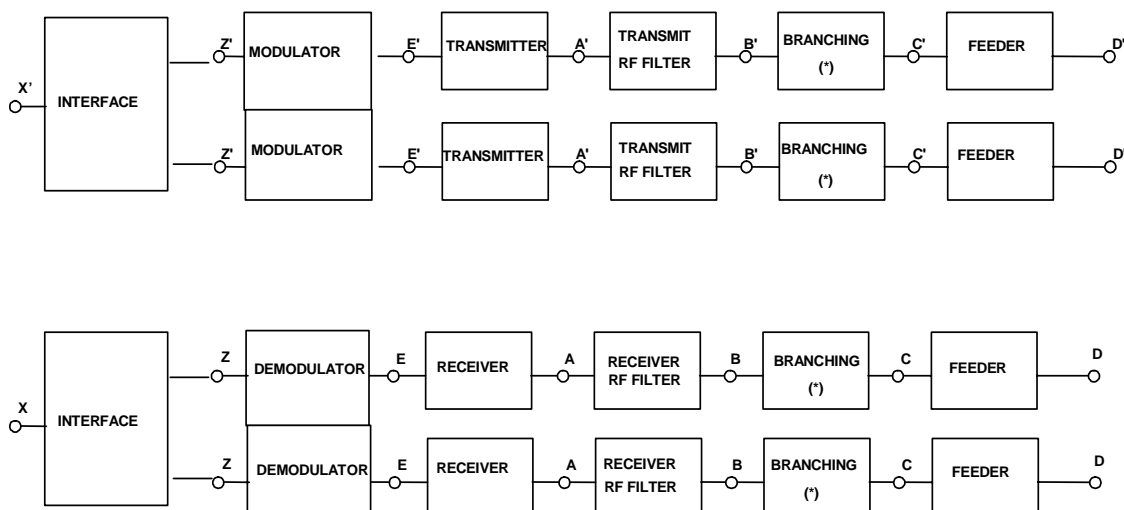

(\*) NO FILTERING

NOTE: A STM-4 or 4 x STM-1 interfaces are used at X and X'.

**Figure 3: 4 x STM-1 or STM-4 System block diagram**

## 4.8 Telecommunications Management Network (TMN) interface

For SDH equipment, ITU-T Recommendations G.784 [38] and G.773 [36] and ITU-R Recommendations F.750 [22] and F.751 [23] give the general requirements for TMN interface and functionality. ETS 300 635 [16], and EN 300 645 [14] give the radio specific functional block description and the related radio-fragment information model respectively.

When the system is configured with STM-4 NNI interface (i.e. the two 55/56MHz channels are composing a single STM-4 air interface), it shall be managed accordingly (e.g. when one or more STM-1 content is lost the overall STM-4 is, in principle, considered faulty). When the system is configured in  $N \times$  STM-1 it shall be managed as a single or multiple STM-1 system.

NOTE: The standardization of TMN interface functionality is under study in ETSI TC TMN, and will be applicable to the radio relay systems considered in the present document.

## 4.9 Branching/feeder/antenna characteristics

### 4.9.1 Antenna radiation patterns

See EN 300 833 [10].

### 4.9.2 Antenna Cross-Polar Discrimination (XPD)

See EN 300 833 [10].

### 4.9.3 Antenna Inter-Port Isolation (IPI)

See EN 300 833 [10].

### 4.9.4 Waveguide flanges (or other connectors)

When flanges are required at reference point C, C', the flanges shall be used according to IEC 60154-2 [46].

## 4.9.5 Return loss

Equipments according to the present document are likely to have integral antennas or very similar technical solutions, without long feeder connections; return loss is not considered essential, therefore no specific requirement is necessary.

---

# 5 System parameters

## 5.1 Transmission capacity

Payload bit rates considered in the present document are:

- 311,040 Mbit/s ( $2 \times \text{STM-1}$ ).
- 622,080 Mbit/s ( $\text{STM-4}$ ,  $4 \times \text{STM-1}$ )

## 5.2 Baseband parameters

All the following specified baseband parameters refer to point X and X' of figures 2 or 3. Parameters for service channels and wayside traffic channels are outside the scope of the present document.

### 5.2.1 SDH baseband interface

The SDH baseband interface shall be in accordance with ITU-T Recommendations G.703 [34], G.707 [35], G.783 [37], G.784 [38], G.957 [42] and ETS 300 635 [16].

One or more of the following baseband interfaces shall be implemented:

- STM-4 optical interface (ITU-T Recommendation G.957 [42]);
- 2 or  $4 \times \text{STM-1}$  optical interface (ITU-T Recommendation G.957 [42]);
- 2 or  $4 \times \text{STM-1}$  CMI electrical interface (ITU-T Recommendation G.703 [34]).

The use of reserved bytes contained in the SOH, and their termination shall be in accordance with ITU-R Recommendation F.750 [22]. Further details on the possible use of the SOH bytes including additional RFCOH or RC SOH are given in TR 101 035 [44].

## 5.3 Transmitter characteristics

The specified transmitter characteristics shall be met with the appropriate baseband signals applied at reference point X' of figure 2 or 3 with the system in full load condition. In case that more than one interfaces is present (i.e.  $2 \times \text{STM-1}$  or  $4 \times \text{STM-1}$ ), the test signal shall be applied to all interfaces. The applicable test signal for testing an SDH interface is defined in ITU-T Recommendation O.181 [43].

### 5.3.1 Transmitter power limit

Transmitter maximum mean output power at reference point C' of the system block diagram (figure 2) shall not exceed +30 dBm (including tolerance and, if applicable, ATPC/RTPC influence).

Regulatory administrations may define nominal sub-ranges below this maximum limit. In particular for 18 GHz band CEPT/ERC/DEC(00)07 [7] requires that the eirp is limited to the minimum necessary to fulfil the performance objectives of the link.

A capability for output power level adjustment may be required for regulatory purposes, in which case the range of adjustment, either by fixed or automatic attenuators, should be in steps of 5 dB or less.

## 5.3.2 Transmit power and frequency control

These requirements are considered essential under article 3.2 of R&TTE Directive [8].

### 5.3.2.1 Transmit Power Control (ATPC and RTPC)

Automatic Transmit Power Control (ATPC) and Remote Transmit Power Control (RTPC).

From the point of view of hardware implementation, Automatic Transmit Power Control (ATPC) and Remote Transmit Power Control (RTPC) functions are made by an electronic attenuator implemented along the transmitting chain (e.g. at IF or at RF level or at both level) and can be realized in a mixed configuration, e.g.:

- ATPC only is implemented;
- RTPC only is implemented;
- ATPC + RTPC are implemented with separate attenuator functions;
- ATPC + RTPC are implemented with a single attenuator complying both functions with different command functions (either HW or SW) and the ranges of both may be traded-off from a maximum available attenuation.

#### 5.3.2.1.1 Automatic Transmit Power Control (ATPC)

For all bands except 18 GHz, the following apply:

ATPC is an optional feature. Equipment with ATPC will be subject to manufacturer declaration of ATPC ranges and related tolerances. The manufacturer shall also declare if the equipment is designed with ATPC as a fixed permanent feature.

For the 18 GHz band the following apply:

For sharing between FS and FSS, ATPC will become a mandatory feature for all new equipment to be deployed after the date referred by CEPT/ERC/DEC(00)07 [7], however the actual usage of ATPC will be required only where practical, depending on local sharing conditions with Satellite Services and local deployment conditions in existing networks. The ATPC range is not subject to standardization. Manufacturer shall declare ATPC ranges and related tolerances.

Testing shall be carried out with output power level corresponding to:

- ATPC set manually to a fixed value for system performance (clauses 5.5 and 5.6);
- ATPC set at maximum available power for transmit performance (clause 5.3).

It shall be verified that the emitted RF spectrum is within the absolute RF spectrum mask evaluated for the maximum available output power of the equipment, including the attenuation introduced by RTPC, if any.

**NOTE:** Administrations should explicitly state whether ATPC is used as a regulatory measure for either frequency coordination or as a mitigation technique to protect other services in its radio interface notification according to article 4.1 of the R&TTE Directive [8]. In this particular case the following applies:

when required for frequency coordination the transmitter output power must meet the spectrum mask limits throughout the ATPC range. This does not apply for 18 GHz, since it is required as a mitigation technique for FS and FSS sharing which is based on EIRP considerations and not on NFD values.



### 5.3.2.1.2 Remote Transmit Power Control (RTPC)

RTPC is an optional feature. Equipment with RTPC will be subject to manufacturer declaration of RTPC ranges and related tolerances. Testing shall be carried out with output power level corresponding to:

- RTPC set to the maximum nominal power for transmit performance (see clause 5.3) and for system performance (see clauses 5.5 and 5.6);
- the RF spectrum mask shall be verified in three points (low, medium, and high) of the RTPC power excursion and with ATPC set to maximum available power (if any). When these spectrum measurements are made difficulties may be experienced. Actual measurement methods shall be addressed in further investigations and will be defined in the conformance testing standard, EN 301 126-1 [9];
- RTPC range should be restricted, taking into account the wideband noise generated by the transmitter chain, to ensure the spectrum mask requirements are met throughout the transmitter output power range.

NOTE: Where the use of ATPC is considered compulsory for national regulatory purposes (see note in clause 5.3.2.1.1) the transmitter output power must meet the spectrum mask limits throughout the ATPC range.

### 5.3.2.2 Remote Frequency Control (RFC)

RFC is an optional feature. Equipment with RFC will be subject to manufacturer declaration of RFC ranges and related change frequency procedure. Testing shall be carried out including:

- RFC setting procedure at least for three frequencies (lower, centre and higher of the covered range);
- RFC setting procedure shall not produce emissions outside the previous and final frequency spectrum mask.

## 5.3.3 Transmitter output power tolerance

The nominal output power shall be declared by the supplier.

From the point of view of declaration of conformity to R&TTE Directive [8], the tolerance of the nominal output power shall be within the range reported in table 2, within the environmental profile declared by the manufacturer for the intended limits of usage of the equipment.

**Table 2: Transmitter output power tolerance**

Frequency	Output power tolerance
32, 38 GHz	±3 dB
28, 26, 23, 18, 15 GHz	±2 dB

As an additional, ETSI voluntary only, requirement, for systems operating within weather protected locations (reported in clause 4.4.1 or similar profiles) the allowable output power tolerance is ±1 dB.

For class 5b systems refer to annex B for further ETSI requirements.

## 5.3.4 Transmit Local Oscillator (LO) frequency arrangements

There shall be no requirement on LO frequency arrangement.

### 5.3.5 RF spectrum mask

The spectrum masks are shown in figures 4a and 4b.

The 0 dB level shown on the spectrum masks relates to the spectral power density of the nominal centre frequency disregarding residual carrier.

Masks shall be measured with a modulating base-band signals given by a PRBS signal given in ITU-T Recommendation O.181 [43].

The recommended spectrum analyser settings for measuring the RF spectrum mask detailed in figures 4a and 4b are shown in table 3:

**Table 3: Spectrum analyser settings for RF power spectrum measurement**

<b>Channel Spacing</b>	<b>[MHz]</b>	<b>56</b>
<b>Centre Frequency</b>		Actual
<b>Sweep width</b>	<b>[MHz]</b>	320
<b>Scan time</b>		Auto
<b>IF bandwidth</b>	<b>[kHz]</b>	100
<b>Video bandwidth</b>	<b>[kHz]</b>	0,3

When a  $4 \times$  STM-1/STM-4 (i.e. dual carrier) system is tested, each carrier will be measured separately, while the other carrier is operating.

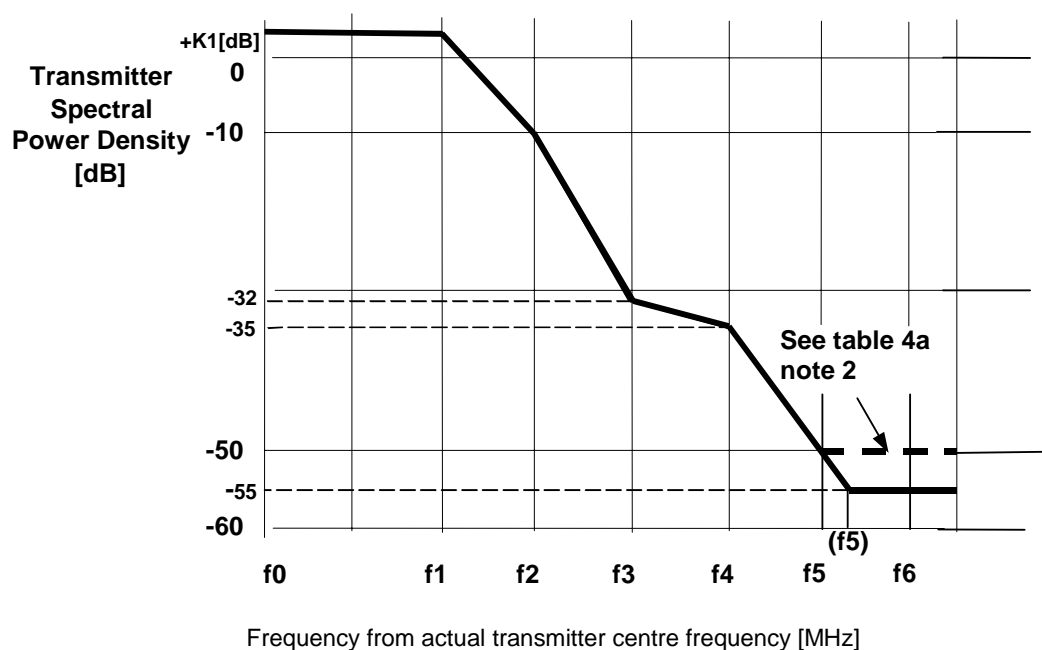

**Figure 4a: Limits of spectral power density for class 5a systems**

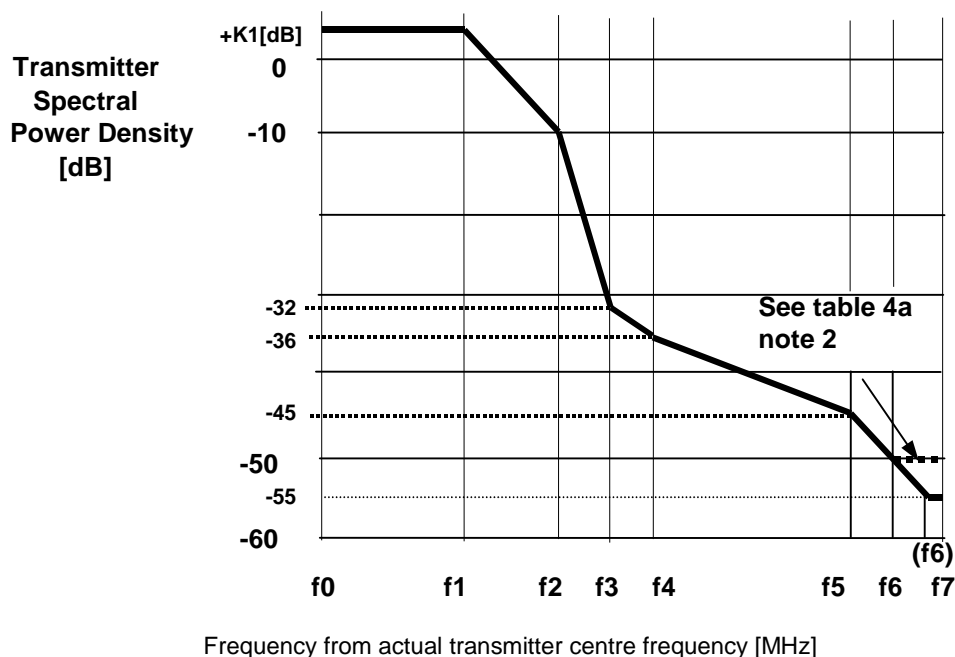

**Figure 4b: Limits of spectral power density for class 5b systems**

Due to limitations of some spectrum analysers, difficulties may be experienced when testing high capacity/wideband systems. In this event, the following options are to be considered: measurement using high performance spectrum analyser, use of notch filters and two step measurement technique. Where difficulties are experienced, the plots of one test conducted at ambient and environmental extremes may be produced as evidence to conformance to the spectrum mask.

Reference frequencies  $f_1$  to  $f_7$  and relative attenuation  $K_1$  [dB] are reported in tables 4a and 4b for the bit rate and channel spacing foreseen:

**Table 4a: Spectrum mask frequency limits for guaranteed RBER (mask floor -55 dB)**

Spectrum efficiency class	Bit-rate [Mbit/s]	Channel spacing [MHz]	Figure	$K_1$ [dB]	$f_1$ [MHz]	$f_2$ [MHz]	$f_3$ [MHz]	$f_4$ [MHz]	$f_5$ [MHz]	$f_6$ [MHz]	$f_7$ [MHz]
5a	311	56	4a	+2	25	30	34	40	100	140	n.a.
5b	311	56	4b	+2	24	29	31	34	80	100	140

NOTE 1: n.a.: not applicable.  
 NOTE 2: The mask floor at 55 dB is required for guaranteeing RBER performance in the presence of multiple adjacent channels, however for regulatory purposes attenuation greater than 50 dB, in bands above 17 GHz, is not required. The corresponding  $f_1 - f_7$  values for a mask floor of 50 dB is as follows.

**Table 4b: Spectrum mask frequency limits for regulatory purposes (mask floor -50 dB) for bands above 17 GHz**

Spectrum efficiency class	Bit-rate [Mbit/s]	Channel spacing [MHz]	Figure	$K_1$ [dB]	$f_1$ [MHz]	$f_2$ [MHz]	$f_3$ [MHz]	$f_4$ [MHz]	$f_5$ [MHz]	$f_6$ [MHz]	$f_7$ [MHz]
5a	311	56	4a	+2	25	30	34	40	85	140	n.a.
5b	311	56	4b	+2	24	29	31	34	80	94	140

## 5.3.6 Discrete CW components exceeding the spectrum mask limit

### 5.3.6.1 Discrete CW components at the symbol rate

The power level (reference point B') of spectral lines at a distance from the channel centre frequency equal to the symbol rate shall be more than 37 dB below the average power level of the carrier for class 5a systems and 43 dB for class 5b systems.

### 5.3.6.2 Other discrete CW components exceeding the spectrum mask limit

In case some CW components exceed the spectrum mask, an additional allowance is given.

Those lines shall not:

- exceed the mask by a factor more than  $(10 \log(\text{CSmin}/\text{IFbandwidth}) - 10)$  dB;
- be spaced each other in frequency by more than CSmin

Where:

CSmin = 1,75 MHz for all frequency bands covered by the present document.

IF bandwidth is the recommended resolution bandwidth reported in table 3.

The above requirement results in 2,4 dB allowance for all bands.

Figure 5 shows a typical example of this requirement.

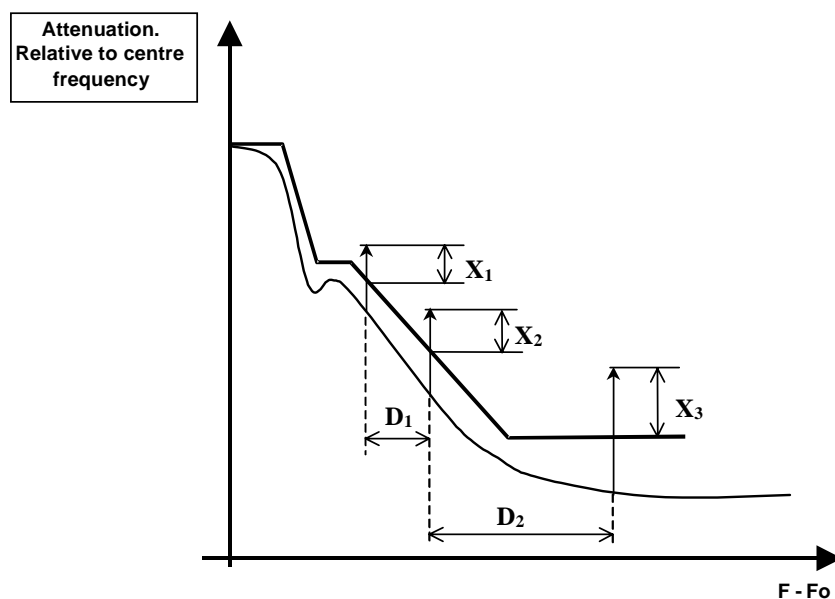

$$X_1, X_2, X_3 \text{ [dB]} \leq 10 \log(\text{CSmin}/\text{BWe}) - 10$$

$$D_1, D_2 \geq \text{CSmin}$$

Figure 5: CW lines exceeding the spectrum mask (typical example)

### 5.3.7 Spurious emissions

It is necessary to define spurious emissions from transmitters for two reasons:

- a) to limit interference into systems operating wholly externally to the system channel plan (external emissions);
- b) to limit local interference within the system where transmitters and receivers are directly connected via the filter and branching systems (internal emissions).

This leads to two sets of spurious emission limits where the specific limits given for "internal" interference are required to be no greater than the "external" level limits at reference point B' for indoor systems and C' for outdoor systems (where a common Tx/Rx duplexer is used).

#### 5.3.7.1 Spurious emissions - external

According to ITU-R Recommendation F.1191 [28] and CEPT/ERC/REC 74-01 [6], the external spurious emissions are defined as emissions at frequencies which are outside the nominal carrier frequency  $\pm 250\%$  of the relevant channel separation. Here assumed to be 55/56 MHz for all systems.

The limits of these emissions shall conform to CEPT/ERC/REC 74-01 [6].

#### 5.3.7.2 Spurious emissions - internal

Given that there is no requirement to multiplex equipment of different manufacturers on the same antenna, there is no requirement for internal spurious emissions.

### 5.3.8 Radio frequency tolerance

Maximum radio frequency tolerance shall not exceed  $\pm 15$  ppm. This limit includes both short-term factors (environmental effects) and long-term ageing effects.

In the type test the manufacturer shall state the guaranteed short-term part and the expected ageing part.

## 5.4 Receiver characteristics

### 5.4.1 Input level range

The upper limit for the receiver input level, where a BER of  $10^{-6}$  is not exceeded shall be -22 dBm.

The upper limit for the receiver input level, where a BER of  $10^{-8}$  is not exceeded shall be -24 dBm.

These limits apply without interference and are referenced to point C. For BER definition and measurement guidance, please refer to annex C. For equipment designed to operate only with ATPC as a fixed permanent feature, the above maximum input levels are reduced by an amount up to the ATPC range.

### 5.4.2 Receiver local oscillator frequency arrangements

There shall be no requirement on LO frequency arrangement.

### 5.4.3 Spurious emissions

The limits of these emissions shall conform to CEPT/ERC/REC 74-01 [6].

## 5.5 System performance without diversity

All parameters are referred to reference point C of figure 2. Losses in RF couplers used for protected systems are not taken into account in the limits specified below.

All measurements shall be carried out with the test signals defined in clause 5.3.

### 5.5.1 BER as a function of Receiver input Signal Level (RSL)

Equipment working at the relevant RSL thresholds, reported in table 5, shall produce a BER equal or less than the corresponding  $10^{-3}$ ,  $10^{-6}$  or  $10^{-8}$ . Receiver BER thresholds (dBm) are referred to reference point C of the system block diagram (see figure 2).

**Table 5: BER performance thresholds**

Frequency Band [GHz]	Spectrum efficiency class	RSL for BER [dBm]		
		$\leq 10^{-3}$	$\leq 10^{-6}$	$\leq 10^{-8}$
15	5	-64	-61	-59
18	5	-63	-60	-58
23	5	-62	-59	-57
26	5	-61	-58	-56
32	5	-60	-57	-55
38	5	-59	-56	-54

For BER definition and measurement guidance, please refer to annex C.

### 5.5.2 Equipment Residual BER

The RBER level under simulated operating conditions without interference shall be guaranteed with a signal level at reference point C which is between 10 dB and 35 dB above the level which gives  $BER = 10^{-6}$  (as specified in clause 5.5.1). However an upper limit above -30 dBm is not required. For BER definition and measurement guidance, please refer to annex C.

To guarantee a higher degree of service, see clause A.4, the network operator may require equipment to meet a RBER limit with the first adjacent channel interferer. In this case the RBER level under simulated operating conditions with interference shall be guaranteed with a signal level at reference point C which is between 15 dB and 35 dB above the level (however, an upper limit above -30 dBm is not required) which gives  $BER = 10^{-6}$  (as specified in clause 5.5.1). The interferer level shall be set to represent a Carrier to Interference ratio (C/I) of +6 dB for class 5a systems (this figure includes a 10 dB offset to account for the minimum cross polar discrimination of these systems), -3 dB or -4 dB for class 5b systems (refer to annex B).

The RBER shall be:  $RBER < 10^{-12}$

This requirement is intended for the payload bit rates defined in clause 5.1.

EN 301 126-1 [9] recognizes that this requirement is subject to a supplier declaration only. However, in clause A.4 some background information relating to the actual test methods and test confidence is given.

### 5.5.3 Interference sensitivity

All receive signal levels and Carrier to Interference ratio (C/I) measurements are referred to reference point C of the RF system block diagram (see figure 1).

### 5.5.3.1 Co-channel interference sensitivity

The limits of Co-channel Interference shall be as in table 6, giving maximum C/I values for 1 dB and 3 dB degradation of the  $10^{-6}$  BER limits specified in clause 5.5.1.

The indicative behaviour for these and other values of degradation may be found in figure A.2.

**Table 6: Co-channel interference sensitivity**

Spectrum efficiency class	C/I	
	BER @ 10-6 RSL 1 dB degradation	BER @ 10-6 RSL 3 dB degradation
5a and 5b	37	33

### 5.5.3.2 Adjacent channel Interference

The limits of adjacent channel interference shall be as given in table 7 for like modulated signals of 1 channel spacing, giving maximum C/I values for 1 dB and 3 dB degradation of the  $10^{-6}$  BER limits specified in clause 5.5.1.

The adjacent channel is intended to be at 55/56 MHz for all systems.

The Indicative behaviour for these and other values of degradation may be found in figure A.3.

**Table 7: First adjacent channel interference sensitivity**

Spectrum efficiency class	C/I	
	BER @ 10-6 RSL 1 dB degradation	BER @ 10-6 RSL 3 dB degradation
5a	+3	-1
5b	-3,5	-7,5

### 5.5.3.3 CW Spurious Interference

For a receiver operating at the  $10^{-6}$  BER threshold given in table 5, the introduction of a CW interferer at a certain level specified below, with respect to the wanted signal and at any frequency in the range 30 MHz to the second harmonic of the upper frequency of the band, excluding frequencies either side of the wanted centre frequency of the RF channel by up to 250 % the channel spacing (intended as 55/56 MHz for all systems), shall not result in a BER greater than  $10^{-5}$ .

The level of the CW interferer shall be: +30 dB.

NOTE: When waveguide is used between ref. point A and C, which length is higher than twice the free space wavelength of the cut-off frequency ( $F_c$ ), the lower limit of measurement will be increased to  $0,7 F_c$  and to  $0,9 F_c$  when the length is higher than 4 times the same wavelength.

This test is designed to identify specific frequencies at which the receiver may have a spurious response, e.g. image frequency, harmonics of the receive filter, etc. The actual test range should be adjusted accordingly. The test is not intended to imply a relaxed specification at all out of band frequencies elsewhere specified in the present document.

### 5.5.4 Cross-Polar Interference Sensitivity for CCDP with XPIC operation

This clause covers specific aspects of the performance of systems where CCDP is used.

The use or not of the XPIC depends on the frequency band, climatic conditions, antenna discrimination and hop length. When those parameters are on a favourable side CCDP could be achieved without the use of an XPIC.

### 5.5.4.1 Co-channel "internal" interference sensitivity in flat fading conditions

The following specifications apply to "internal" interference from the cross-polarized channel of the same system.

For the frequency bands given under clause 5.1 the limits of the co-channel interference sensitivity for the system shall be as given in table 8.

**Table 8: Degradation versus S/I in co-channel "internal" interference**

<b>Reference BER</b>	<b>10<sup>-6</sup></b>	<b>10<sup>-6</sup></b>
RSL Degradation	1 dB	3 dB
S/I (dB)	16	13

Referring to the measurement test bench in clause A.2 note that measurement has to be made adding the same values of noise and interference to both paths, and varying the phase shifter of the interfering path we have to find the worst condition for this characteristic (see clause A.2).

### 5.5.4.2 Co-channel "internal" interference sensitivity in dispersive fading conditions

This requirement is considered to be applied to the equipment in the frequency ranges 15 GHz and 18 GHz only.

To evaluate the performances during multipath propagation, dispersive cross-polarized main signals and non-dispersive cross-polarization interferences are used in test bench in clause A.2.

In this static characteristic the notch positions are maintained at the centre frequency and C/N is maintained sufficiently high (i.e.: C/N > 35 dB).

In the above defined measurement conditions, keeping the notches frequency and depth equal on both paths, the BER = 10<sup>-6</sup> signature limits, with a significant value of XPI, shall be given in table 9.

**Table 9: Signature limits**

<b>XPI (dB)</b>	<b>Signature Width</b>	<b>Notch Depth [dB]</b>
15	±36 MHz	5 dB

### 5.5.5 Distortion sensitivity

Outage from multi-path phenomena is not considered relevant for the systems in frequency bands higher than 18 GHz.

This requirement is considered to be applied to the equipment in the frequency ranges 15 GHz and 18 GHz only.

Equalizers to compensate propagation distortion may be considered necessary. The specifications for distortion sensitivity are given below in the form of signatures.

Class 5 signatures:

For two path propagation with a delay of 6,3 ns and a BER of 10<sup>-6</sup> the width of the signature shall not exceed ±36 MHz relative to the assigned channel centre frequency, the depth shall not be less than 8 dB.

These limits are both valid for minimum and non-minimum phase cases.

## 5.6 System characteristics with diversity

Space diversity receive is not relevant for the systems subject to the present document.



## Annex A (informative): Additional information

### A.1 Cross-Polar Discrimination (XPD) of the antenna

The measured effective XPD over a typical hop (13 km at 15 GHz, 10 km at 18 GHz) under non-fading conditions is considered not less than 28 dB.

### A.2 Measurement test set for XPI characteristics

We define in figure A.1a a measurement set-up that allows to simulate wanted signals affected by flat and/or dispersive fading conditions in presence of XPI (Cross Polar Interference) which level and phase can also be varied.

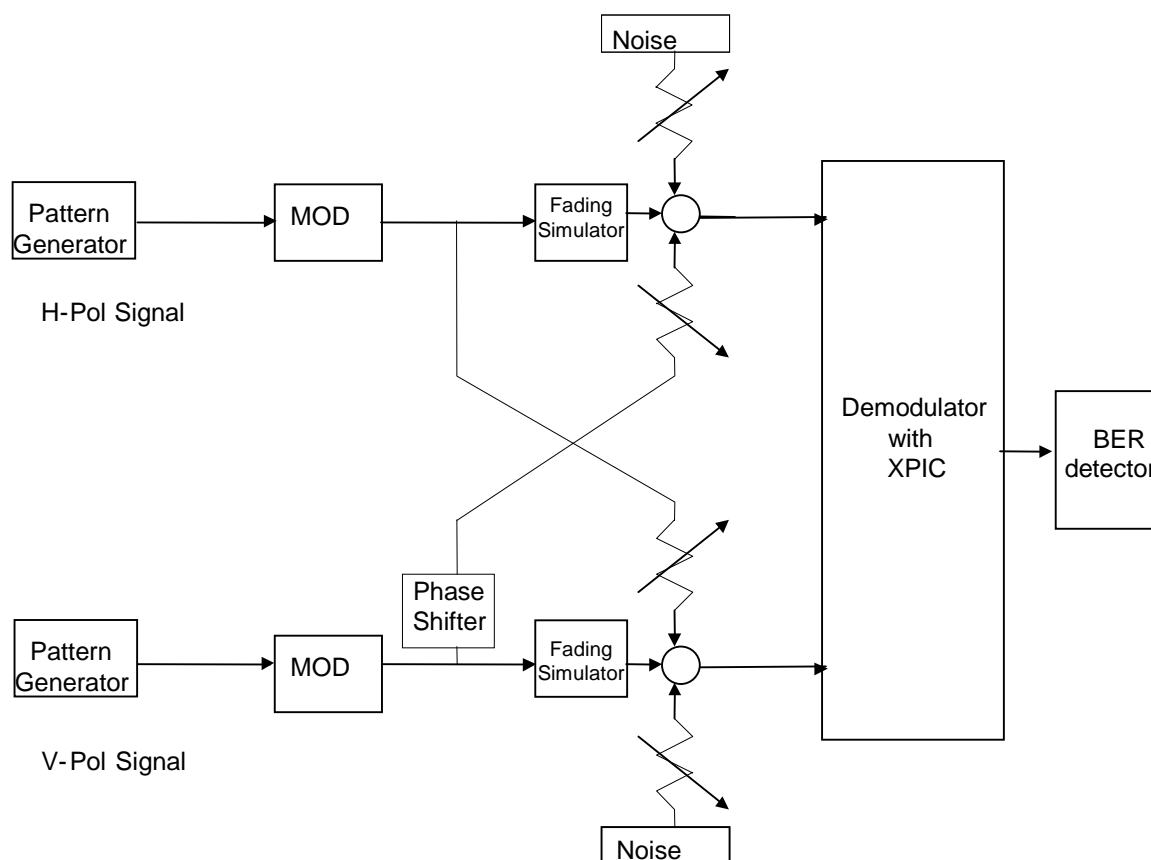

Figure A.1a: IF Measurement test set

As an alternative a full RF test set-up may be used as reported in figure A.1b.

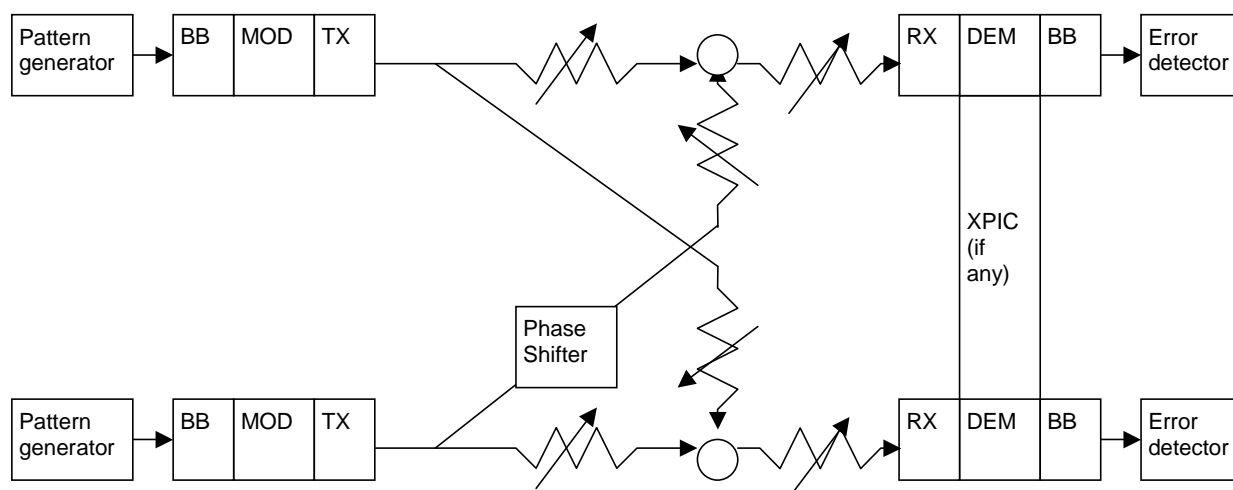

Figure A.1b: RF Measurement test set

## A.3 Automatic Transmit Power Control (ATPC)

ATPC may be useful in some circumstances, e.g.:

- as mitigation technique for improving sharing with other Services;
- to reduce interference between neighbouring systems or adjacent channels of the same system;
- to improve compatibility with analogue and digital systems at nodal stations;
- to improve residual BER or RBER performance;
- to reduce upfading problems;
- to reduce transmitter power consumption;
- to reduce digital-to-digital and digital to analogue distant interference between hops which re-use the same frequency;
- to increase system gain as a countermeasure against rainfall attenuation.

ATPC as an optional feature is aimed at driving the transmit power amplifier output level from a proper minimum which facilitates the radio network planning requirements and which is used under normal propagation conditions up to a maximum value which fulfils all the specifications defined in the present document.

ATPC may also be used to increase the output power above the nominal level up to the maximum level specified by the manufacturer, with the agreement of administrations and operators, during fading conditions. This can be useful because in frequency ranges above 13 GHz the main limiting factors are given by non-selective fading events.

For planning considerations in a nodal environment a system equipped with ATPC can be considered to operate with its minimum transmitter power.

When ATPC is a fixed feature, the ATPC range is defined as the power interval from the maximum (including tolerances) output power level to the lowest transmitter output power level (at reference point B') with ATPC; when it is optional two ranges may be defined, a "down-range" from the nominal level to the minimum (including tolerances) and an "up-range" from the nominal level to the maximum (including tolerances).

## A.4 RBER

In particular applications, where there is a high density of radio links in a specific area, e.g. nodal site, closely located radios may use adjacent channels. Therefore to guarantee the grade of service the equipment will need to meet RBER criteria in the presence of an adjacent channel interferer.

The RBER is standardized in order to match the ESR (or the BBR) performance required by ITU-R transmission performance recommendations.

To have sufficient confidence in the measurement, where the BER is relatively low compared to the actual pay load, the test time is very long. The actual background to this measurement and the BER figures are detailed in TR 101 036-1 [45].

When error correction is a fitted feature it may be possible to reduce the measurement time by estimating the RBER using the relevant formula declared by the supplier.

Another option is to ensure that no errors occur during the minimum recording time shown in table A.1. Please refer to annex C for further details.

**Table A.1: Zero errors recording times**

<b>Bit-rate under test [Mbit/s]</b>	<b>Minimum recording time [minutes]</b>	<b>errors</b>
155	108	0
622	27	0

## A.5 Co-channel and adjacent channel interference

The performances for co-channel and adjacent channel spaced by one channel spacing  $C/I$  are reported in clauses 5.5.3.1 and 5.5.3.2 respectively, for 1 dB and 3 dB degradation only; figures A.2 and A.3 give the indicative behaviour for other values of degradation. The values represented should not be used for frequency co-ordination purposes.

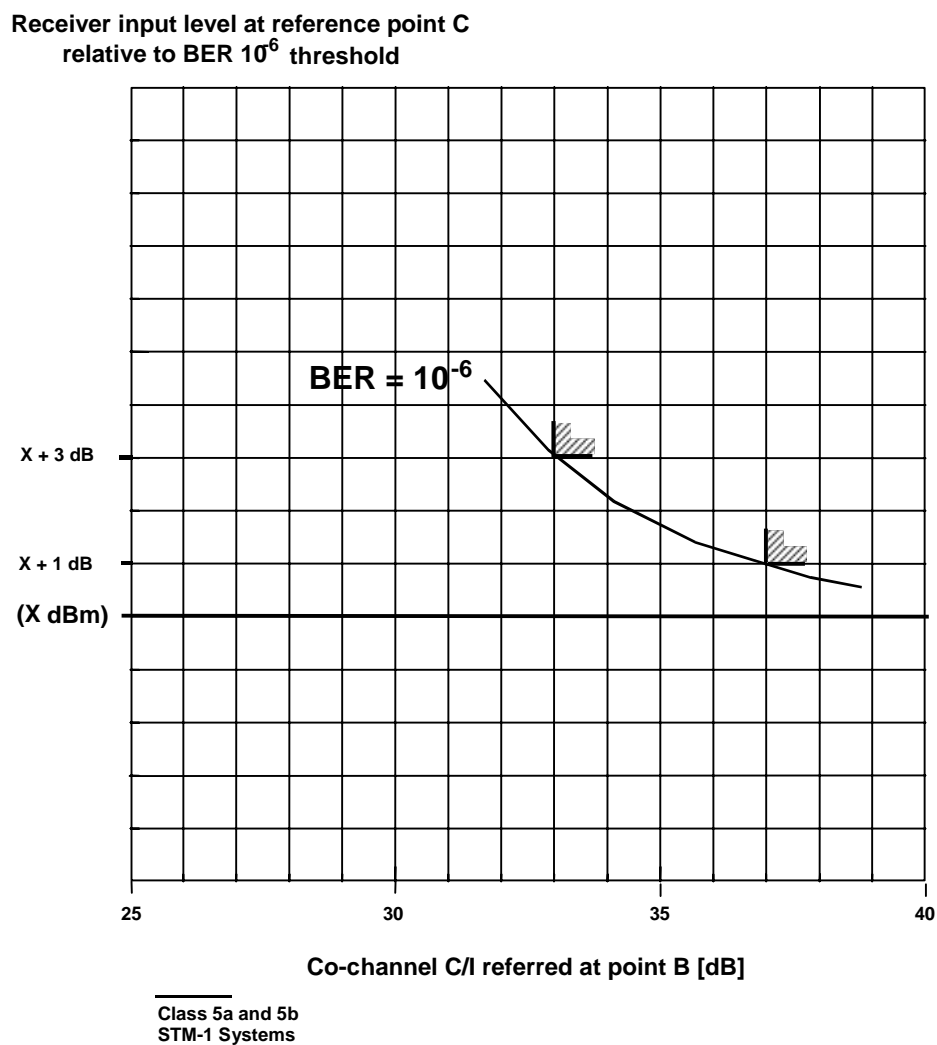

NOTE:  $X \text{ dBm} = 10^{-6}$  BER threshold provided by clause 5.5.1.

Figure A.2: Co-channel interference threshold degradation

Receiver input level at reference point C  
relative to BER  $10^{-6}$  threshold

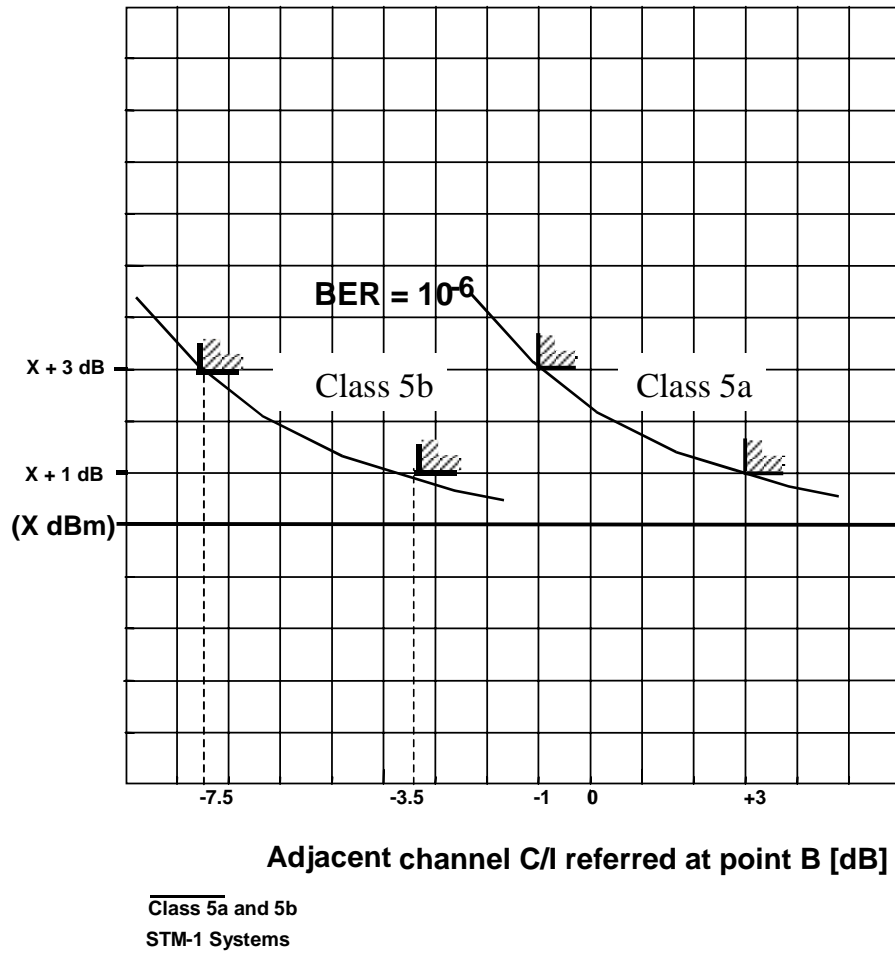

Figure A.3: Adjacent channel interference threshold degradation

---

## Annex B (normative): Output Power Tolerance and RBER

Class 5b systems are basically sensitive systems (e.g. 128 state with a roll off of approximately 20 %) standardized for network applications that include adjacent channels on a parallel route, sometimes with terminal co-located stations shared by different network operators. In such cases, even if nominal power (or EIRP) is kept equal through common spectrum management practice, the power tolerance may endanger proper error performance with particular regard to Errored Seconds objectives. Therefore, the RBER is required to be maintained with an adjacent C/I signal depending on the declared output power tolerance as shown in table B.1.

**Table B.1: RBER measurement criteria with 1<sup>st</sup> adjacent channel interference**

Output Power Tolerance	1st Adjacent Channel C/I
±2 dB	-4
±3 dB	-6

## Annex C (normative): BER measurement in a multi-interface, multi-carrier system

The present document deals with systems that either have several STM-1 interfaces, several RF carriers or a combination of both. In order to keep alignment of the requirements in the present document to single carrier single interface standards, there is need to modify the basic requirements according to the system type. BER and performance measurements need to take into consideration the system type and configuration. The purpose of this annex is to provide guidance for measurement and planning of these systems.

**Case 1:**  $2 \times$  STM-1 multi-interface, single carrier or  $4 \times$  STM-1 (see note), multi-interface, multi-carrier systems.

Test equipment will be connected to one of the STM-1 interfaces. The resulting BER shall comply with the requirements in the present document.

All measurements of performance are identical to other single interface, single carrier systems.

NOTE: Specifically for  $4 \times$  STM-1 systems which are implemented as two  $2 \times$  STM-1 carriers. The measurement will be done on one of the carriers only.

**Case 2:** STM-4 single interface, multi-carrier system.

Test equipment will be connected to the STM-4 interface. The resulting BER shall comply with the requirements in the present document as described in table C.1.

**Table C.1: Resulting BER for STM-4**

Clause	Measurement	Test Method	BER requirement
5.4.1	Input Level Range	Both carriers simultaneously	As specified
5.5.1	BER vs. RSL	Both carriers Simultaneously	As specified
5.5.2	Residual BER	Both carriers Simultaneously	As specified
5.5.3.1	External Co-channel and adjacent channel Interference	The RSL is set on both carriers at the $10^{-6}$ threshold, as specified in clause 5.5.1. The interferer and the 1 dB (3 dB) degradation is applied on one carrier only.	As specified

**Case 3:**  $4 \times$  STM-1 multi-interface, multi-carrier system where each STM-1 payload is transmitted on both carriers.

Test equipment will be connected to one of the STM-1 interfaces. The resulting BER shall comply with the requirements in the present document as described in table C.2.

**Table C.2: Resulting BER for STM-1**

Clause	Measurement	Test Method	BER requirement
5.4.1	Input Level Range	Both carriers	As specified
5.5.1	BER vs RSL	Both carriers	As specified
5.5.2	Residual BER	Both carriers	As specified
5.5.3.1	Co-channel and adjacent channel Interference	The RSL is set on both carriers at the $10^{-6}$ threshold, as specified in clause 5.5.1. The interferer, together with the 1 dB (3 dB) degradation is applied on one carrier at a time, on both carriers (two measures).	As specified (see note). Compliance to the limits shall be guaranteed during both measures.
NOTE: The $10^{-6}$ threshold degradation shall be obtained as a sum, on the same STM-1, during the two measures, therefore the BER limits shall be modified accordingly (e.g. twice $5 \times 10^{-7}$ instead of $1 \times 10^{-6}$ ). For planning purposes, please note that if there is interference on both carriers, the resulting BER will be $1 \times 10^{-6}$ .			

---

## History

<b>Document history</b>			
V1.1.1	June 2002	Public Enquiry	PE 20021011: 2002-06-12 to 2002-10-11
V1.1.1	October 2002	Vote	V 20021227: 2002-10-28 to 2002-12-27
V1.1.1	January 2003	Publication	