

Draft **ETSI EN 302 018** V2.0.3 (2016-12)



HARMONISED EUROPEAN STANDARD

**Transmitting equipment for the
Frequency Modulated (FM) sound broadcasting service;
Harmonised Standard covering the essential requirements
of article 3.2 of Directive 2014/53/EU**

Reference

REN/ERM-TG17-013

Keywords

audio, broadcasting, FM, harmonised standard,
radio, regulation, terrestrial, transmitter

ETSI

650 Route des Lucioles
F-06921 Sophia Antipolis Cedex - FRANCE

Tel.: +33 4 92 94 42 00 Fax: +33 4 93 65 47 16

Siret N° 348 623 562 00017 - NAF 742 C
Association à but non lucratif enregistrée à la
Sous-Préfecture de Grasse (06) N° 7803/88

Important notice

The present document can be downloaded from:
<http://www.etsi.org/standards-search>

The present document may be made available in electronic versions and/or in print. The content of any electronic and/or print versions of the present document shall not be modified without the prior written authorization of ETSI. In case of any existing or perceived difference in contents between such versions and/or in print, the only prevailing document is the print of the Portable Document Format (PDF) version kept on a specific network drive within ETSI Secretariat.

Users of the present document should be aware that the document may be subject to revision or change of status. Information on the current status of this and other ETSI documents is available at
<https://portal.etsi.org/TB/ETSIDeliverableStatus.aspx>

If you find errors in the present document, please send your comment to one of the following services:
<https://portal.etsi.org/People/CommiteeSupportStaff.aspx>

Copyright Notification

No part may be reproduced or utilized in any form or by any means, electronic or mechanical, including photocopying and microfilm except as authorized by written permission of ETSI.

The content of the PDF version shall not be modified without the written authorization of ETSI.
The copyright and the foregoing restriction extend to reproduction in all media.

© European Telecommunications Standards Institute 2016.
All rights reserved.

DECT™, **PLUGTESTS™**, **UMTS™** and the ETSI logo are Trade Marks of ETSI registered for the benefit of its Members.
3GPP™ and **LTE™** are Trade Marks of ETSI registered for the benefit of its Members and of the 3GPP Organizational Partners.
GSM® and the GSM logo are Trade Marks registered and owned by the GSM Association.

Contents

Intellectual Property Rights	6
Foreword.....	6
Modal verbs terminology.....	6
Introduction	6
1 Scope	7
2 References	7
2.1 Normative references	7
2.2 Informative references.....	7
3 Definitions, symbols and abbreviations	8
3.1 Definitions	8
3.2 Symbols.....	9
3.3 Abbreviations	9
4 Technical requirements specifications	10
4.1 Environmental profile.....	10
4.2 Conformance requirements	10
4.2.1 Rated output power.....	10
4.2.1.1 Definition	10
4.2.1.2 Limit.....	10
4.2.1.3 Conformance.....	10
4.2.2 Frequency drift.....	10
4.2.2.1 Definition	10
4.2.2.2 Limit.....	10
4.2.2.3 Conformance.....	10
4.2.3 Deviation sensitivity stability	10
4.2.3.1 Definition	10
4.2.3.2 Limit.....	10
4.2.3.3 Conformance	11
4.2.4 Residual AM (Hum and noise)	11
4.2.4.1 Definition	11
4.2.4.2 Limits	11
4.2.4.3 Conformance.....	11
4.2.5 Synchronous AM (AM due to FM)	11
4.2.5.1 Definition	11
4.2.5.2 Limit.....	11
4.2.5.3 Conformance.....	11
4.2.6 Modulator performance (pulse response)	11
4.2.6.1 Definition	11
4.2.6.2 Limit.....	11
4.2.6.3 Conformance.....	12
4.2.7 MPX intermodulation	12
4.2.7.1 Definition	12
4.2.7.2 Limit.....	12
4.2.7.3 Conformance.....	12
4.2.8 Deviation limiting.....	12
4.2.8.1 Definition	12
4.2.8.2 Limit.....	12
4.2.8.3 Conformance.....	12
4.2.9 FM Signal to Noise Ratio (SNR)	12
4.2.9.1 Definition	12
4.2.9.2 Limit.....	13
4.2.9.3 Conformance.....	13
4.2.10 Spurious emissions	13
4.2.10.1 Definition	13
4.2.10.2 Limit.....	13

4.2.10.3	Conformance	14
4.2.11	Transmitter muting during frequency shift	14
4.2.11.1	Definition	14
4.2.11.2	Limit	14
4.2.11.3	Conformance	14
4.2.12	Out-of-band emissions	15
4.2.12.1	Definition	15
4.2.12.2	Limit	15
4.2.12.3	Conformance	15
5	Testing for compliance with technical requirements	16
5.1	Environmental conditions for testing	16
5.2	Interpretation of the measurement results	16
5.3	Methods of measurement	16
5.3.1	Rated output power	16
5.3.1.1	Initial conditions	16
5.3.1.2	Procedure	17
5.3.1.2	Test requirements	17
5.3.2	Frequency drift	17
5.3.2.1	Initial conditions	17
5.3.2.2	Procedure	17
5.3.2.3	Test requirements	17
5.3.3	Deviation sensitivity stability	18
5.3.3.1	Initial conditions	18
5.3.3.2	Procedure	18
5.3.3.3	Test requirements	18
5.3.4	Residual AM (Hum and noise)	18
5.3.4.1	Initial conditions	18
5.3.4.2	Procedure	19
5.3.4.3	Test requirements	19
5.3.5	Synchronous AM (AM due to FM)	19
5.3.5.1	Initial conditions	19
5.3.5.2	Procedure	19
5.3.5.3	Test requirements	20
5.3.6	Modulator performance (pulse response)	20
5.3.6.1	Initial conditions	20
5.3.6.2	Procedure	20
5.3.6.3	Test requirements	21
5.3.7	MPX intermodulation	21
5.3.7.1	Initial conditions	21
5.3.7.2	Procedure	21
5.3.7.3	Test requirements	21
5.3.8	Deviation limiting	22
5.3.8.1	Initial conditions	22
5.3.8.2	Procedure	22
5.3.8.3	Test requirements	22
5.3.9	FM Signal to Noise Ratio (SNR)	23
5.3.9.1	Initial conditions	23
5.3.9.2	Procedure	23
5.3.9.3	Test requirements	23
5.3.10	Spurious emissions	23
5.3.10.1	Initial conditions	23
5.3.10.2	Procedure	24
5.3.10.3	Test requirements	24
5.3.11	Transmitter muting during frequency shift	24
5.3.11.1	Initial conditions	24
5.3.11.2	Procedure	24
5.3.11.3	Test requirements	25
5.3.12	Out-of-band emissions	25
5.3.12.1	Initial conditions	25
5.3.12.2	Procedure	25
5.3.12.3	Test requirements	26

Annex A (informative):	Relationship between the present document and the essential requirements of Directive 2014/53/EU	27
Annex B (normative):	General measuring arrangements	28
B.1	Testing arrangements for antenna port measurements	28
B.1.1	Testing arrangement for monophonic transmitters	28
B.1.2	Testing arrangement stereophonic transmitters	29
B.1.3	Test frequency range	30
B.1.4	Test modulating signal	30
B.2	Test load characteristics	32
Annex C (informative):	Change History	33
History		34

Intellectual Property Rights

IPRs essential or potentially essential to the present document may have been declared to ETSI. The information pertaining to these essential IPRs, if any, is publicly available for **ETSI members and non-members**, and can be found in ETSI SR 000 314: "*Intellectual Property Rights (IPRs); Essential, or potentially Essential, IPRs notified to ETSI in respect of ETSI standards*", which is available from the ETSI Secretariat. Latest updates are available on the ETSI Web server (<https://ipr.etsi.org>).

Pursuant to the ETSI IPR Policy, no investigation, including IPR searches, has been carried out by ETSI. No guarantee can be given as to the existence of other IPRs not referenced in ETSI SR 000 314 (or the updates on the ETSI Web server) which are, or may be, or may become, essential to the present document.

Foreword

This draft Harmonised European Standard (EN) has been produced by ETSI Technical Committee Electromagnetic compatibility and Radio spectrum Matters (ERM), and is now submitted for the combined Public Enquiry and Vote phase of the ETSI standards EN Approval Procedure.

The present document has been prepared under the Commission's standardisation request C(2015) 5376 final [i.4] to provide one voluntary means of conforming to the essential requirements of Directive 2014/53/EU on the harmonisation of the laws of the Member States relating to the making available on the market of radio equipment and repealing Directive 1999/5/EC [i.1].

Once the present document is cited in the Official Journal of the European Union under that Directive, compliance with the normative clauses of the present document given in table A.1 confers, within the limits of the scope of the present document, a presumption of conformity with the corresponding essential requirements of that Directive, and associated EFTA regulations.

Proposed national transposition dates	
Date of latest announcement of this EN (doa):	3 months after ETSI publication
Date of latest publication of new National Standard or endorsement of this EN (dop/e):	6 months after doa
Date of withdrawal of any conflicting National Standard (dow):	18 months after doa

Modal verbs terminology

In the present document "**shall**", "**shall not**", "**should**", "**should not**", "**may**", "**need not**", "**will**", "**will not**", "**can**" and "**cannot**" are to be interpreted as described in clause 3.2 of the [ETSI Drafting Rules](#) (Verbal forms for the expression of provisions).

"**must**" and "**must not**" are **NOT** allowed in ETSI deliverables except when used in direct citation.

Introduction

The present document describes the requirements for the design and operation of an FM sound broadcasting service transmitter to meet the essential requirements of article 3.2 of Directive 2014/53/EU [i.1].

1 Scope

The present document specifies technical characteristics and methods of measurements for transmitter equipment for broadcast sound services using the frequency modulated sound broadcasting service operating in the frequency range 68 MHz to 108 MHz.

The present document covers the essential requirements of article 3.2 of Directive 2014/53/EU [i.1] under the conditions identified in annex A.

2 References

2.1 Normative references

References are specific, identified by date of publication and/or edition number or version number. Only the cited version applies.

Referenced documents which are not found to be publicly available in the expected location might be found at <https://docbox.etsi.org/Reference/>.

NOTE: While any hyperlinks included in this clause were valid at the time of publication, ETSI cannot guarantee their long term validity.

The following referenced documents are necessary for the application of the present document.

- [1] Recommendation ITU-R BS.468-4 (1986): "Measurement of audio-frequency noise voltage level in sound broadcasting".
- [2] Recommendation ITU-R BS.450-3 (2001): "Transmission standards for FM sound broadcasting at VHF".

2.2 Informative references

References are either specific (identified by date of publication and/or edition number or version number) or non-specific. For specific references, only the cited version applies. For non-specific references, the latest version of the referenced document (including any amendments) applies.

NOTE: While any hyperlinks included in this clause were valid at the time of publication, ETSI cannot guarantee their long term validity.

The following referenced documents are not necessary for the application of the present document but they assist the user with regard to a particular subject area.

- [i.1] Directive 2014/53/EU of the European Parliament and of the Council of 16 April 2014 on the harmonisation of the laws of the Member States relating to the making available on the market of radio equipment and repealing Directive 1999/5/EC.
- [i.2] ETSI TR 100 028-1: "Electromagnetic compatibility and Radio spectrum Matters (ERM); Uncertainties in the measurement of mobile radio equipment characteristics; Part 1".
- [i.3] ETSI TR 100 028-2: "Electromagnetic compatibility and Radio spectrum Matters (ERM); Uncertainties in the measurement of mobile radio equipment characteristics; Part 2".
- [i.4] Commission Implementing Decision C(2015) 5376 final of 4.8.2015 on a standardisation request to the European Committee for Electrotechnical Standardisation and to the European Telecommunications Standards Institute as regards radio equipment in support of Directive 2014/53/EU of the European Parliament and of the Council.
- [i.5] Recommendation ITU-R BS.412 (1998): "Planning standards for terrestrial FM sound broadcasting at VHF".

- [i.6] Recommendation ITU-R BS.641 (1986): "Determination of radio-frequency protection ratios for frequency-modulated sound broadcasting".

3 Definitions, symbols and abbreviations

3.1 Definitions

For the purposes of the present document, the terms and definitions given in Directive 2014/53/EU [i.1] and the following apply:

antenna port: port of an apparatus which is designed, in normal operation, to be connected to an antenna using coaxial cable

broadcasting service: radio communication service in which the transmissions are intended for direct reception by the general public

NOTE: This service may include sound transmissions, television transmissions or other types of transmission.

channel L: left hand channel of a stereophonic signal

channel R: right hand channel of a stereophonic signal

carrier power: average power supplied to the antenna port by a transmitter during one cycle taken under the condition of no modulation

class of emission: set of characteristics of an emission, designated by standard symbols, e.g. type of modulation of the main carrier, modulating signal, type of information to be transmitted, and also, if appropriate, any additional signal characteristics

composite: See "Multiplex (MPX) signal".

dBc: decibels relative to the unmodulated carrier power of the emission

NOTE: In the cases which do not have a carrier, for example in some digital modulation schemes where the carrier is not accessible for measurement, the reference level equivalent to dBc is decibels relative to the mean power P.

difference signal: signal (S) theoretically equal to half the difference between the left (L) and right (R) stereophonic signals. $S = (L - R) / 2$

exclusion band: band of radio frequencies where no measurements are made

frequency tolerance: maximum permissible departure of the characteristic frequency of an emission from the assigned frequency

NOTE: The frequency tolerance is expressed in parts per 10^6 or in Hz.

harmonic: component of order greater than 1 of the Fourier series of a periodic quantity

harmonic number: integral number given by the ratio of the frequency of a harmonic to the fundamental frequency (second harmonic = $2 \times$ fundamental frequency)

mean power: average power supplied to the antenna port by a transmitter during an interval of time sufficiently long compared with the lowest frequency encountered in the modulation envelope taken under normal operating conditions

MultiPleX (MPX) signal: contains all information, including the pilot tone and any supplementary signal which is used to frequency modulate the VHF FM transmitter

necessary bandwidth: for a given class of emission, the width of the frequency band which is sufficient to ensure the transmission of information at the rate and with the quality required under specified conditions

out-of-band emissions: emission on a frequency or frequencies immediately outside the necessary bandwidth which results from the modulation process, but excluding spurious emissions

pilot tone: 19 kHz tone used to recover the stereo subcarrier in the stereo-receiver

reference bandwidth: bandwidth in which the emission level is specified

signal L: corresponds to the information in the left channel of the stereophonic signal

signal R: corresponds to the information in the right channel of the stereophonic signal

spurious emissions: emission on a frequency or frequencies which are outside the necessary bandwidth and the level of which may be reduced without affecting the corresponding transmission of information

NOTE: Spurious emissions include harmonic emissions, parasitic emissions, intermodulation products and frequency conversion products but exclude out of band emissions.

stereo subcarrier: 38 kHz subcarrier used to carry the difference signal

sum signal: signal (M) theoretically equal to half of the sum of the left (L) and right (R) stereophonic signals.

$$M = (L + R) / 2$$

unwanted emissions: consist of spurious emissions and out of band emissions

3.2 Symbols

For the purposes of the present document, the following symbols apply:

Ω	ohms (unit of resistance)
μ	micro, 10^{-6}

3.3 Abbreviations

For the purposes of the present document, the following abbreviations apply:

a.c.	alternating current
AF	Audio Frequency
AM	Amplitude Modulation
BS	Broadcast Sound
d.c.	direct current
dB	deciBel
dBm	dB relative to one milliwatt
EC	European Commission
EFTA	European Free Trade Area
EN	European Norm
ERM	Electromagnetic compatibility and Radio spectrum Matters
EUT	Equipment Under Test
FM	Frequency Modulation
Hz	Hertz (cycles per second)
MPX	MultiPleX
RF	Radio Frequency
rms	root mean square
SNR	Signal to Noise Ratio
V	Volts
VHF	Very High Frequency

4 Technical requirements specifications

4.1 Environmental profile

The technical requirements of the present document apply under the environmental profile for operation of the equipment, which shall be declared by the manufacturer. The equipment shall comply with all the technical requirements of the present document which are identified as applicable in annex A at all times when operating within the boundary limits of the declared operational environmental profile.

4.2 Conformance requirements

4.2.1 Rated output power

4.2.1.1 Definition

The rated output power is the carrier power that the EUT shall deliver at its antenna port under manufacturers specified conditions of operation.

4.2.1.2 Limit

The carrier output power shall be within $\pm 0,5$ dB of the rated output power under normal operating conditions as defined by the manufacturer.

4.2.1.3 Conformance

Conformance tests as defined in clause 5.3.1 shall be carried out.

4.2.2 Frequency drift

4.2.2.1 Definition

The frequency drift of an emission is the uncontrolled continuous and irreversible variation of frequency against a predetermined timescale.

4.2.2.2 Limit

For a period of not less than ninety days, the frequency tolerance of the transmitter shall stay within ± 300 Hz.

4.2.2.3 Conformance

Conformance tests as defined in clause 5.3.2 shall be carried out.

4.2.3 Deviation sensitivity stability

4.2.3.1 Definition

Stability of the required audio or MPX input level to the transmitter to achieve desired deviation.

4.2.3.2 Limit

- a) The deviation sensitivity of the transmitters shall remain within ± 3 % of the declared value under the manufacturers declared operating conditions.

- b) For frequency-agile transmitters the deviation sensitivity shall remain within ± 5 % of the declared value under the manufacturers declared operating conditions.

4.2.3.3 Conformance

Conformance tests as defined in clause 5.3.3 shall be carried out.

4.2.4 Residual AM (Hum and noise)

4.2.4.1 Definition

The amplitude modulated hum and noise level is the peak voltage of the a.c. component at the output of a linear envelope detector, in the absence of any modulation signal. The result is expressed as a percentage of the d.c. component of the envelope detector output.

4.2.4.2 Limits

The permitted level of residual AM in the absence of modulation shall not exceed 1 % when measured in a bandwidth of 20 Hz to 20 kHz (unweighted).

4.2.1.3 Conformance

Conformance tests as defined in clause 5.3.4 shall be carried out.

4.2.5 Synchronous AM (AM due to FM)

4.2.5.1 Definition

Synchronous amplitude modulation is evaluated by measuring the peak voltage of the a.c. component at the output of a linear envelope detector due to presence of a specified modulating signal. The result is expressed as a percentage of the d.c. component corresponding to the unmodulated carrier.

4.2.5.2 Limit

The permitted level of AM due to FM shall not exceed 2 % for a peak deviation of ± 40 kHz at a modulation frequency of 500 Hz.

4.2.5.3 Conformance

Conformance tests as defined in clause 5.3.5 shall be carried out.

4.2.6 Modulator performance (pulse response)

4.2.6.1 Definition

The amplitude and phase performance required for the transmitter to ensure compliance with the maximum frequency deviation.

NOTE: If the amplitude and phase performance of a modulator is out of tolerance the pulse response leads to the result of overdeviation respectively underdeviation. Overdeviation leads to a wider spectrum and in case of clipping etc. to intermodulation products.

4.2.6.2 Limit

The frequency deviation limits in table 4.1 shall apply.

Table 4.1: Frequency deviation limits

Audio frequency	Adjusted frequency deviation via sine-wave	Measured frequency deviation via clipped sine-wave/trapezoid
40 Hz	40 kHz \pm 3 %	40 kHz \pm 10 %
10 kHz	40 kHz \pm 3 %	40 kHz \pm 10 %
NOTE: In the case of monophonic transmitters, the "clipped sine wave" limits do not apply.		

4.2.6.3 Conformance

Conformance tests as defined in clause 5.3.6 shall be carried out.

4.2.7 MPX intermodulation

4.2.7.1 Definition

Distortion products of the MPX-signal caused by base-band intermodulation effects of the modulator.

4.2.7.2 Limit

The amplitude of the 1 kHz second order intermodulation product shall be less than -50 dB relative to the amplitude of the test tones.

4.2.7.3 Conformance

Conformance tests as defined in clause 5.3.7 shall be carried out.

4.2.8 Deviation limiting

4.2.8.1 Definition

The capability of the limiter function to keep the deviation inside specified limits.

4.2.8.2 Limit

The deviation limits in table 4.2 shall apply.

Table 4.2: Deviation limits

Maximum operating frequency deviation	Peak deviation
50 kHz	\pm 50 kHz \pm 3 %
75 kHz	\pm 75 kHz \pm 3 %

4.2.8.3 Conformance

Conformance tests as defined in clause 5.3.8 shall be carried out.

4.2.9 FM Signal to Noise Ratio (SNR)

4.2.9.1 Definition

The FM noise level is the voltage, either unweighted (unfiltered) or weighted (filtered) measured as quasi peak according to Recommendation ITU-R BS.468-4 [1], clause 2, of the a.c. components at the output of the demodulator in absence of a modulation signal expressed in dB relative to a reference level corresponding to maximum frequency deviation of \pm 75 kHz at a modulation frequency of 500 Hz.

4.2.9.2 Limit

The SNR, measured on both decoded outputs and related to full rated output power at 500 Hz and ± 75 kHz deviation, shall be:

- unweighted SNR ≥ 72 dB;
- weighted SNR ≥ 72 dB.

4.2.9.3 Conformance

Conformance tests as defined in clause 5.3.9 shall be carried out.

4.2.10 Spurious emissions

4.2.10.1 Definition

Emission on a frequency or frequencies which are outside the necessary bandwidth and the level of which may be reduced without affecting the corresponding transmission of information. Spurious emissions include harmonic emissions, parasitic emissions, intermodulation products and frequency conversion products but exclude out of band emissions.

4.2.10.2 Limit

Spurious emissions shall not exceed the values set out in table 4.3, shown additionally in figure 4.1 for the frequency range 9 kHz to 1 GHz.

Table 4.3: Spurious emission limits

Mean power of the transmitter	Limits Mean power absolute levels (dBm) or relative levels (dBc) below the power supplied to the antenna port in the reference bandwidth (see annex B)
$P < 9$ dBW	-36 dBm
9 dBW $\leq P < 29$ dBW	75 dBc
29 dBW $\leq P < 39$ dBW	-16 dBm
39 dBW $\leq P < 50$ dBW	85 dBc
50 dBW $\leq P$	-5 dBm
NOTE: Within the band 108 MHz to 137 MHz the limits above apply without exceeding the absolute limit of 25 μ W (-16 dBm).	

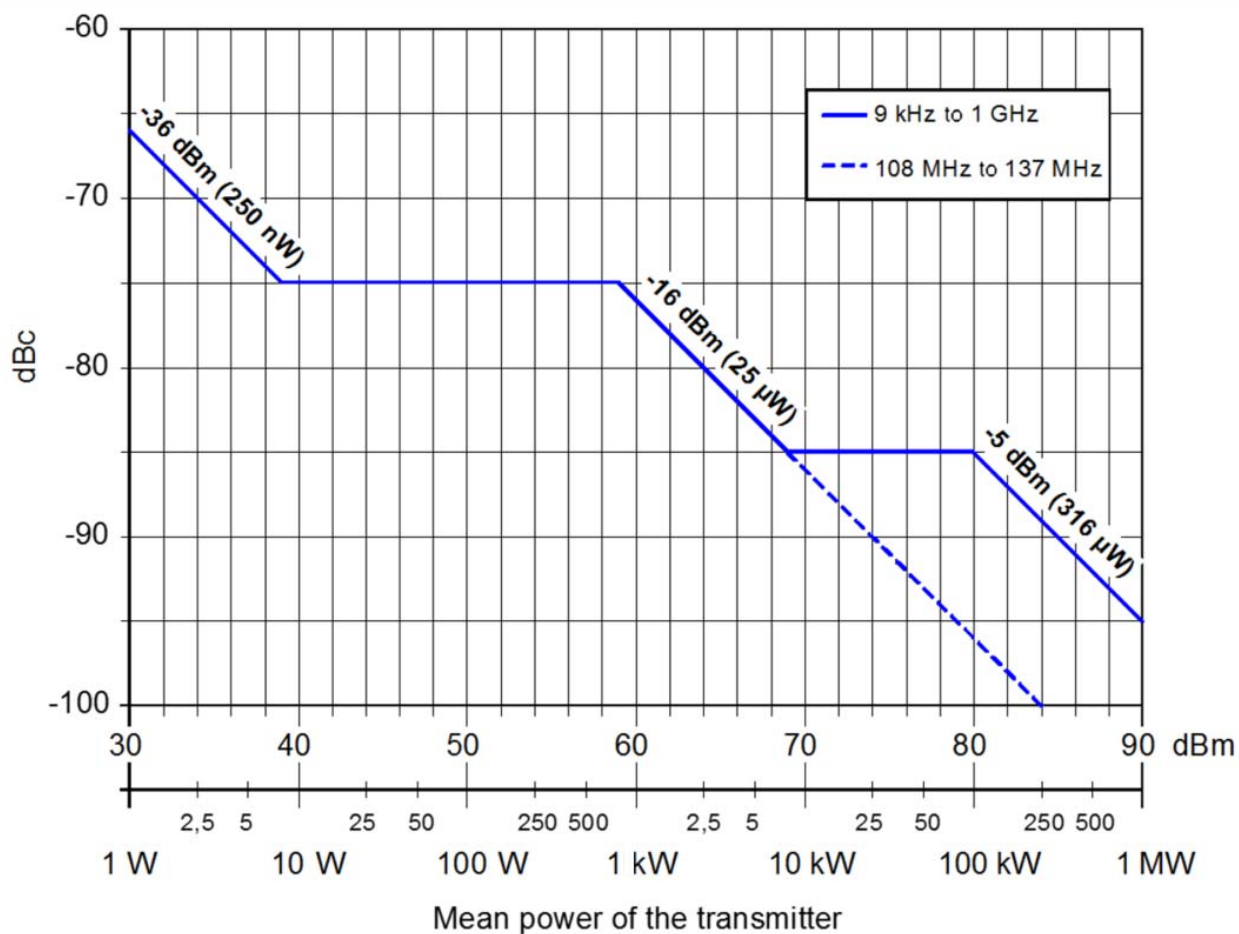

Figure 4.1: Spurious emission limits for FM sound broadcasting transmitters

4.2.10.3 Conformance

Conformance tests as defined in clause 5.3.10 shall be carried out.

4.2.11 Transmitter muting during frequency shift

4.2.11.1 Definition

The suppression of emissions during the retuning of transmitters or the loss of carrier frequency control. This is particularly relevant to frequency agile transmitters incorporating frequency control loops.

4.2.11.2 Limit

The Muting shall be as defined in table 4.3 and additionally shown in figure 4.1.

4.2.11.3 Conformance

Conformance tests as defined in clause 5.3.11 shall be carried out.

4.2.12 Out-of-band emissions

4.2.12.1 Definition

Emission on a frequency or frequencies immediately outside the necessary bandwidth, which results from the modulation process, but excludes spurious emissions.

4.2.12.2 Limit

Out of band emissions shall not exceed the values set out in table 4.4 and additionally shown in figure 4.2.

Table 4.4: Break points of spectrum limit mask for VHF FM sound broadcasting

Frequency relative to the centre of the channel (kHz)	Relative level (dBc)
-500	-85
-300	-85
-200	-80
-100	0
100	0
200	-80
300	-85
500	-85

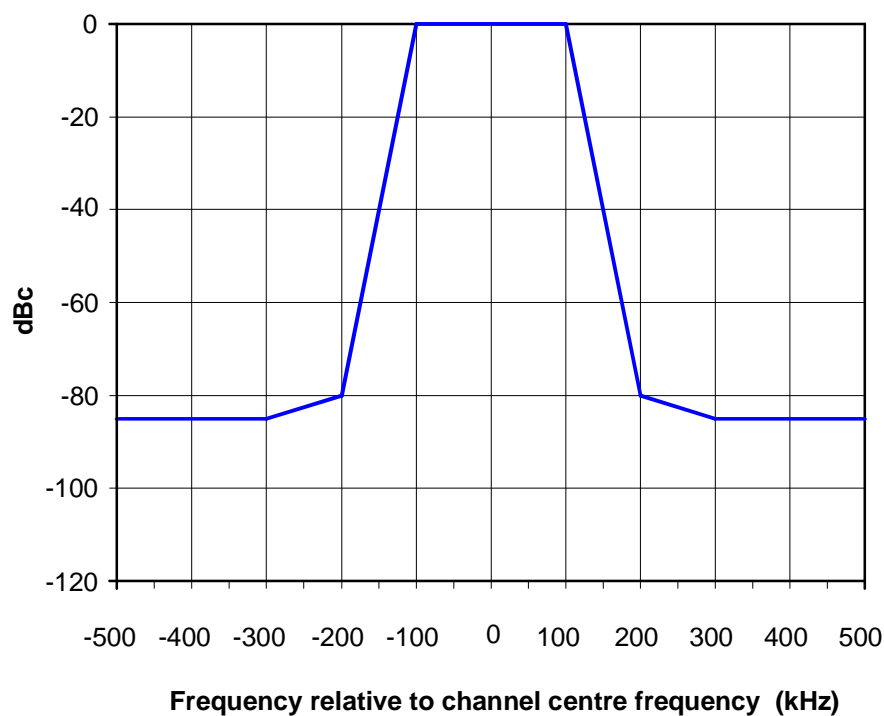

Figure 4.2: Out-of-band emission limits for FM sound broadcasting transmitters

4.2.12.3 Conformance

Conformance tests as defined in clause 5.3.12 shall be carried out.

5 Testing for compliance with technical requirements

5.1 Environmental conditions for testing

Tests defined in the present document shall be carried out at representative points within the boundary limits of the declared operational environmental profile.

Where technical performance varies subject to environmental conditions, tests shall be carried out under a sufficient variety of environmental conditions (within the boundary limits of the declared operational environmental profile) to give confidence of compliance for the affected technical requirements.

5.2 Interpretation of the measurement results

The interpretation of the results recorded in a test report for the measurements described in the present document shall be as follows:

- the measured value related to the corresponding limit shall be used to decide whether an equipment meets the requirements of the present document;
- the value of the measurement uncertainty for the measurement of each parameter shall be included in the test report;
- the recorded value of the measurement uncertainty shall be, for each measurement, equal to or less than the figures in table 5.1.

For the test methods, according to the present document, the measurement uncertainty figures shall be calculated and shall correspond to an expansion factor (coverage factor) $k = 1,96$ or $k = 2$ (which provide confidence levels of respectively 95 % and 95,45 % in the case where the distributions characterizing the actual measurement uncertainties are normal (Gaussian)). Principles for the calculation of measurement uncertainty are contained in ETSI TR 100 028-1 [i.2], in particular in annex D of the ETSI TR 100 028-2 [i.3].

Table 5.1 is based on such expansion factors.

Table 5.1: Maximum measurement uncertainty

Parameter	Uncertainty
Rated output power	3,0 dB
Frequency drift	3 Hz
Deviation sensitivity stability	0,1 %
Residual AM	0,02 %
Synchronous AM	0,02 %
Modulator performance	0,1 %
MPX intermodulation	3,0 dB
Deviation limiting	0,1 %
FM Signal to Noise Ratio	3,0 dB
Spurious emissions (conducted emissions)	3,0 dB
Transmitter muting	3,0 dB
Out-of-band emissions (conducted emissions)	3,0 dB

5.3 Methods of measurement

5.3.1 Rated output power

5.3.1.1 Initial conditions

Test environment:

- the normal operating environment, as declared by the equipment manufacturer.

Test frequencies:

- a) the lowest operating frequency of the EUT;
- b) the highest operating frequency of the EUT;
- c) a frequency mid-way between a) and b) above.

Test arrangement (see figure B.1):

- 1) connect the EUT to the Test Load, via the Coupling Device;
- 2) connect the Spectrum Analyser or power meter to the Coupling Device.

The AF Signal Generator and Voltage measuring equipment are not required for this test.

5.3.1.2 Procedure

- 1) operate the EUT at each of the test frequencies as defined in clause 5.3.1.1;
- 2) measure the results on the Spectrum Analyser or power meter.

5.3.1.2 Test requirements

The results obtained shall be compared to the limits in clause 4.2.1.2 in order to demonstrate compliance.

5.3.2 Frequency drift

5.3.2.1 Initial conditions

Test environment:

- the normal operating environment, as declared by the equipment manufacturer.

Test frequency:

- any one frequency within the tuning range of the EUT.

Test arrangement (see figure B.1):

- 1) connect the EUT to the Test Load, via the Coupling Device;
- 2) connect a frequency recorder to the Coupling Device.

The AF Signal Generator and Voltage measuring equipment are not required for this test.

5.3.2.2 Procedure

- 1) operate the exciter of the EUT at the test frequency as defined in clause 5.3.2.1;
- 2) measure the results on the frequency recorder.

5.3.2.3 Test requirements

The results obtained shall be compared to the limits in clause 4.2.2.2 in order to demonstrate compliance.

5.3.3 Deviation sensitivity stability

5.3.3.1 Initial conditions

Test environment:

- the normal operating environment, as declared by the equipment manufacturer.

Test frequencies:

- a) the lowest operating frequency of the EUT;
- b) the highest operating frequency of the EUT;
- c) a frequency mid-way between a) and b) above.

Test arrangement (see figure B.1):

- 1) connect the AF Signal Generator to the EUT;
- 2) connect the EUT to the Test Load, via the Coupling Device;
- 3) connect deviation recording equipment to the Coupling Device.

5.3.3.2 Procedure

- 1) Switch the preemphasis off.
- 2) Using a single sinus AF the manufacturer has to define an AF input level that meets the rated deviation. Operate the EUT with this AF input level.
- 3) Set the RF operating frequency constant and change the AF frequency in the range declared by the manufacturer, but not outside the frequency range 40 Hz to 15 kHz.
- 4) Measure the deviation. This shall be compared to the limits in clause 4.2.3.2, item a) in order to demonstrate compliance.

For frequency agile transmitters:

- 1) Repeat item 3) at other RF operating frequencies including the lowest and highest operating frequency as specified in clause 5.3.3.1.
- 2) Measure the deviation. This shall be compared to the limits in clause 4.2.3.2, item b) in order to demonstrate compliance.

5.3.3.3 Test requirements

The results obtained shall be compared to the limits in clause 4.2.3.2 in order to demonstrate compliance.

5.3.4 Residual AM (Hum and noise)

5.3.4.1 Initial conditions

Test environment:

- the normal operating environment, as declared by the equipment manufacturer.

Test arrangement:

- see figure B.1 in the case where no stereo coder is present and figure B.2 in the case where a stereo coder is present in the transmitter.
- 1) connect the EUT to the Test Load, via the Coupling Device;

- 2) connect a linear Envelope Detector to the Coupling Device;
- 3) connect a Peak Voltmeter and a d.c. Voltmeter to the output of the Envelope Detector. Alternatively, a Modulation Meter may be used.

5.3.4.2 Procedure

- 1) if applicable, switch the stereo coder in monophonic mode;
- 2) check that the appropriate de- and pre-emphasis filters are in circuit;
- 3) no input signal is applied to the transmitter or stereo coder;
- 4) connect the audio input terminal(s) of the transmitter or stereo coder to a load impedance corresponding to the nominal source impedance;
- 5) measure the d.c. component (U_0) at the detector output which corresponds to the carrier output;
- 6) measure the peak a.c. voltage (U_s) at the Envelope Detector output.

5.3.4.3 Test requirements

Calculate the noise and hum level by means of the following formula:

$$N = 100 \frac{U_s}{U_0} (\%)$$

When a modulation meter is used the result is indicated directly.

The results obtained shall be compared to the limits in clause 4.2.4.2 in order to demonstrate compliance.

5.3.5 Synchronous AM (AM due to FM)

5.3.5.1 Initial conditions

Test environment:

- the normal operating environment, as declared by the equipment manufacturer.

Test arrangement:

- see figure B.1 in the case where no stereo coder is present and figure B.2 in the case where a stereo coder is present in the transmitter.
- 1) connect the EUT to the Test Load, via the Coupling Device;
 - 2) connect a linear Envelope Detector to the Coupling Device;
 - 3) connect a Peak Voltmeter and a d.c. Voltmeter to the output of the Envelope Detector. Alternatively, a Modulation Meter may be used.

5.3.5.2 Procedure

- 1) if applicable, switch the stereo coder to monophonic mode;
- 2) check that the appropriate de- and pre-emphasis filters are in circuit;
- 3) adjust input signal to a frequency within the audio-frequency band;
- 4) adjust input signal level for specified deviation (normally maximum deviation);
- 5) measure the d.c. component (U_0) at the Envelope Detector output;

- 6) measure the a.c. component (U_a) at the Envelope Detector output.

5.3.5.3 Test requirements

Calculate the amplitude modulation depth expressed as a percentage by means of the following formula:

$$m = 100 \frac{U_a}{U_0} (\%)$$

for each audio-frequency.

Present the AM depth levels as a function of the audio-frequency and state the deviation with the results.

When a modulation meter is used for the measurements, the results can be influenced by noise and hum.

The results obtained shall be compared to the limits in clause 4.2.5.2 in order to demonstrate compliance.

5.3.6 Modulator performance (pulse response)

5.3.6.1 Initial conditions

As a measure of the modulator performance the pulse response is taken without audio processing like stereo coder and preemphasis. Therefore, the audio processing unit if existing is bridged and the MPX input of the transmitter is used.

For the measurement two test signals are taken with an amplitude that corresponds to a frequency deviation of 40 kHz. (40 kHz is chosen in order to avoid an unwanted clipping inside the modulator due to ringing or tilt of the test signals).

The two test tones are derived from sine wave signals (40 Hz and 10 kHz) by clipping at 25 % (-12 dB) of the crest of the sine wave. The amplitude of the clipped sine wave has to be adjusted to a level that is equal to the peak level of a sine wave that results in a 40 kHz frequency deviation.

Alternatively to the use of the clipped sine waves, trapezoidal pulse with a slew rate that is equal to the slew rate of the clipped sine wave, can be used.

Test environment:

- the normal operating environment, as declared by the equipment manufacturer.

Test frequencies:

- a) the lowest operating frequency of the EUT;
- b) the highest operating frequency of the EUT;
- c) a frequency mid-way between a) and b) above.

Test arrangement (see figure B.1):

- 1) connect the AF Signal Generator to the EUT;
- 2) connect the EUT to the Test Load, via the Coupling Device;
- 3) connect deviation measure equipment to the Coupling Device.

5.3.6.2 Procedure

- 1) bridge the audioprocessor or use the MPX input;
- 2) set the AF Signal Generator to deliver a test signal sine wave signal of 1 kHz;
- 3) adjust the peak sine wave signal to level that results in a modulation with 40 kHz peak deviation and determine the peak voltage of the sine wave signal (Oscilloscope);

- 4) replace the sine wave signal by one of the two test tones and adjust the level of the test signal to the peak level determined in item 3);
- 5) measure the peak frequency from the deviation measurement equipment.

5.3.6.3 Test requirements

The results obtained shall be compared to the limits in clause 4.2.6.2 in order to demonstrate compliance.

5.3.7 MPX intermodulation

5.3.7.1 Initial conditions

Test environment:

- the normal operating environment, as declared by the equipment manufacturer.

Test frequencies:

- a frequency mid-way between the lowest and the highest operating frequency of the EUT.

Test arrangement (see figure B.1):

- 1) connect two AF Signal Generators to the EUT; if available, use the multiplex signal input; otherwise use the supplementary signal input;
- 2) connect the EUT to the Test Load, via the Coupling Device;
- 3) connect deviation measurement equipment to the Coupling Device;
- 4) connect an AF Spectrum Analyser to the output of the deviation measurement equipment.

The modulator shall be able to generate FM signals in accordance with Recommendation ITU-R BS.450-3 [2], recommends 1. The amplitude and phase performance of the modulator has to ensure compliance with the Out of Band emission mask and the maximum allowed frequency deviation.

5.3.7.2 Procedure

- 1) Modulate the transmitter with a signal, consisting of two single tone AF frequencies with the same amplitude and with a frequency difference of approximately 1 kHz.
- 2) Choose the test frequencies from the range of 15 kHz to the end of the supplementary information channel, for example 76 kHz.
- 3) Increase the combined output levels of both AF Generators to achieve the maximum frequency deviation of ± 75 kHz.
- 4) Using the AF Spectrum Analyser; measure:
 - the amplitude level of the test tones;
 - the amplitude level of the second order intermodulation product which has the frequency of 1 kHz.

5.3.7.3 Test requirements

The results obtained shall be compared to the limits in clause 4.2.7.2 in order to demonstrate compliance.

5.3.8 Deviation limiting

5.3.8.1 Initial conditions

Test environment:

- the normal operating environment, as declared by the equipment manufacturer.

Test frequencies:

- a frequency mid-way between the lowest and the highest operating frequency of the EUT.

Test arrangement (see figure B.1):

- 1) connect the AF Signal Generator to the EUT; if available, use the multiplex signal input; otherwise use the supplementary signal input.
- 2) connect the EUT to the Test Load, via the Coupling Device;
- 3) connect deviation measurement equipment to the Coupling Device;
- 4) enable the deviation limiter.

The modulator shall be able to generate FM signals in accordance with Recommendation ITU-R BS.450-3 [2], recommends 1. The amplitude and phase performance of the modulator has to ensure compliance with the Out of Band emission mask and the maximum allowed frequency deviation.

The deviation shall not exceed the limits for European countries given in Recommendation ITU-R BS.450-3 [2], recommends 1, i.e. 75 kHz or 50 kHz, if the deviation limiter is enabled.

5.3.8.2 Procedure

For monophonic operation:

- 1) modulate the transmitter with a sinewave AF signal;
- 2) adjust the output of the AF Generator at 1 kHz to a level which corresponds to a frequency deviation of ± 32 kHz, i.e. 7,4 dB below maximum deviation of ± 75 kHz;
- 3) increase the output level of the AF Generator by 12 dB, resulting in a frequency deviation of approximately ± 128 kHz with the deviation limiter disabled;
- 4) enable the deviation limiter and measure the results from the deviation measurement equipment.

For stereophonic operation:

- 1) both channels L and R shall be fed simultaneously with an AF signal in the ratio $L = R - 6$ dB (channel L with half the amplitude of channel R);
- 2) adjust the output of the AF Generator at 1 kHz to a level which corresponds to a frequency deviation of ± 40 kHz including the pilot tone;
- 3) increase the output level of the AF Generator by 12 dB, resulting in a frequency deviation of approximately ± 145 kHz with the deviation limiter disabled;
- 4) enable the deviation limiter and measure the results from the deviation measurement equipment.

5.3.8.3 Test requirements

The results obtained shall be compared to the limits in clause 4.2.8.2 in order to demonstrate compliance.

5.3.9 FM Signal to Noise Ratio (SNR)

5.3.9.1 Initial conditions

Test environment:

- the normal operating environment, as declared by the equipment manufacturer.

Test frequencies:

- a) the lowest operating frequency of the EUT;
- b) the highest operating frequency of the EUT;
- c) a frequency mid-way between a) and b) above.

Test arrangement (see figure B.2 for stereophonic or B.1 for monophonic only transmitters):

- 1) connect the AF Signal Generator to the EUT;
- 2) connect the EUT to the Test Load, via the Coupling Device;
- 3) connect a suitable modulation test device to the output of the Coupling Device (with a quasi-peak detector as in Recommendation ITU-R BS.468-4 [1] clause 2 with pre-emphasis and de-emphasis in).

5.3.9.2 Procedure

- 1) set the AF Signal Generator to deliver a test signal of 500 Hz, sine wave, at a level to achieve 100 % modulation (75 kHz deviation);
- 2) measure the reference voltage;
- 3) disconnect the AF Signal Generator from the EUT and terminate the input according to the manufacturers recommendation;
- 4) measure the weighted and unweighted voltage and compare to the reference voltage;
- 5) repeat the above procedure at each of the test frequencies as defined in clause 5.3.9.1.

5.3.9.3 Test requirements

The results obtained shall be compared to the limits in clause 4.2.9.2 in order to demonstrate compliance.

5.3.10 Spurious emissions

5.3.10.1 Initial conditions

Test environment:

- the normal operating environment, as declared by the equipment manufacturer.

Test frequencies:

- a) the lowest operating frequency of the EUT;
- b) the highest operating frequency of the EUT;
- c) a frequency mid-way between a) and b) above.

Test arrangement (see figure B.1):

- 1) connect the AF Signal Generator to the EUT;
- 2) connect the EUT to the Test Load, via the Coupling Device;

- 3) connect the Spectrum Analyser to the Coupling Device.

5.3.10.2 Procedure

- 1) measure the peak power of the unmodulated carrier on the Spectrum Analyser and set its value as a reference;
- 2) operate the EUT at each of the test frequencies as defined in clause 5.3.10.1;
- 3) measure the peak power of harmonic emissions on the Spectrum Analyser;
- 4) set the AF Signal Generator to deliver a test signal as defined in clause B.1.4;
- 5) measure the peak power of the modulated carrier on the Spectrum Analyser and set its value as a reference;
- 6) operate the EUT at each of the test frequencies as defined in clause 5.3.10.1;
- 7) measure the results on the Spectrum Analyser.

Measurements shall be made in the operational mode producing the largest emission in the frequency band.

5.3.10.3 Test requirements

The results obtained shall be compared to the limits in clause 4.2.10.2 in order to demonstrate compliance.

5.3.11 Transmitter muting during frequency shift

5.3.11.1 Initial conditions

Test environment:

- the normal operating environment, as declared by the equipment manufacturer.

Test frequencies:

- a) the lowest operating frequency of the EUT;
- b) the highest operating frequency of the EUT.

Test arrangement (see figure B.1):

- 1) connect the EUT to the Test Load, via the Coupling Device;
- 2) connect the Spectrum Analyser to the Coupling Device;
- 3) set reference bandwidth as per clause B.1.3;
- 4) set span to correspond to the tuneable frequency range shown at clause 5.3.11.1 points "a" and "b";
- 5) sweep time of the spectrum analyser should be not greater than 1/10 the frequency switching period of the EUT.

The AF Signal Generator and Voltage measuring equipment are not required for this test.

If it is not possible to attain the necessary dynamic range in the Spectrum Analyser, the measuring range can be split into several parts.

5.3.11.2 Procedure

- 1) operate the EUT at the present frequency as defined in clause 5.3.11.1, item a);
- 2) initiate frequency change to frequency defined in clause 5.3.11.1, item b);
- 3) to measure the results set the spectrum analyser to "MAX HOLD" and retune the EUT at least 5 times between the frequencies defined in clause 5.3.11.1, item a) and item b).

5.3.11.3 Test requirements

The results obtained shall be compared to the limits in clause 4.2.11.2 in order to demonstrate compliance.

5.3.12 Out-of-band emissions

5.3.12.1 Initial conditions

Test environment:

- the normal operating environment, as declared by the equipment manufacturer.

Test frequencies:

- a) the lowest operating frequency of the EUT; the highest operating frequency of the EUT;
- b) a frequency mid-way between a) and b) above.

Test arrangement (see figure B.1):

- 1) connect the AF Signal Generator to the EUT;
- 2) connect the EUT to the Test Load, via the Coupling Device;
- 3) connect the Spectrum Analyser to the Coupling Device.

5.3.12.2 Procedure

For monophonic operation:

The test arrangement in clause B.1.1 shall be used.

One generator shall be a AF Signal Generator. The other generator shall deliver standardized coloured noise described in clause B.1.4. This can be obtained from a "white-noise" generator after a passive filter, as shown in figure B.4, and a low-pass filter of 15 kHz with a slope of 60 dB per octave.

A second output from a directional coupler is connected to a RF Spectrum Analyser.

- 1) check that the pre- and de-emphasis filters are in circuit;
- 2) adjust the output of the AF generator at 1 kHz to a level which corresponds to a frequency deviation of ± 32 kHz, i.e. 7,4 dB below maximum deviation of ± 75 kHz;
- 3) measure the effective value by means of the noise meter (see note) at the input of the EUT modulator;
- 4) switch the AF Generator out of circuit and the Noise Generator in circuit and adjust the output of the noise generator, so that the noise meter gives the same reading; the peak-deviation is now correct.
- 5) switch the Analyser to a bandwidth of 1 kHz;
- 6) adjust the Spectrum Analyser with the unmodulated FM carrier to 0 dB as reference level;
- 7) modulate the transmitter with the coloured noise;
- 8) tune the Analyser to frequencies between the carrier frequency and ± 100 kHz to ± 500 kHz, i.e. to all frequencies required in the out of band emission(s) mask;
- 9) determine the r.m.s. value of the noise corresponding to power density, relative to the unmodulated carrier level;
- 10) operate the EUT at each of the test frequencies as defined in clause 5.3.12.1.

For stereophonic operation:

The test arrangement in clause B.1.2, shall be used.

The AF Signal Generator has to be replaced during the measurement by the standard Coloured Noise Generator. Both channels L and R shall be fed simultaneously with an AF signal or with white noise in the ratio $L = R - 6$ dB:

- 1) check that the appropriate pre- and de-emphasis filters are in circuit;
- 2) adjust the output of the AF Generator at ≤ 1 kHz to a level which corresponds to a frequency deviation 7,4 dB below maximum rated deviation and additionally include pilot tone. That is ± 40 kHz for ± 75 kHz rated deviation;
- 3) measure the effective power value by means of the Noise Meter (see note) at the input of the EUT Stereo Coder in channel R;
- 4) for the remaining procedure, see the method used for monophonic operation.

NOTE: The Noise Meter has to be applicable to determine a true effective value (rms) of power or voltage of a stochastic noise probe. Suitable instruments are bolometric power meters or psophometric voltage meters. All and any weighting networks have to be disconnected.

The Noise Meter has to be applicable to determine a true effective value (rms) of power or voltage of a stochastic noise probe. Suitable instruments are bolometric power meters or psophometric voltage meters. All and any weighting networks have to be disconnected.

5.3.12.3 Test requirements

The results obtained shall be compared to the limits in clause 4.2.12.2 in order to demonstrate compliance.

Annex A (informative): Relationship between the present document and the essential requirements of Directive 2014/53/EU

The present document has been prepared under the Commission's standardisation request C(2015) 5376 final [i.4] to provide one voluntary means of conforming to the essential requirements of Directive 2014/53/EU on the harmonisation of the laws of the Member States relating to the making available on the market of radio equipment and repealing Directive 1999/5/EC [i.1].

Once the present document is cited in the Official Journal of the European Union under that Directive, compliance with the normative clauses of the present document given in table A.1 confers, within the limits of the scope of the present document, a presumption of conformity with the corresponding essential requirements of that Directive, and associated EFTA regulations.

Table A.1: Relationship between the present document and the essential requirements of Directive 2014/53/EU

Harmonised Standard ETSI EN 302 018				
Requirement			Requirement Conditionality	
No	Description	Reference: Clause No	U/C	Condition
1	Rated output power	4.2.1	U	
2	Frequency drift	4.2.2	U	
3	Deviation sensitivity stability	4.2.3	U	
4	Residual AM	4.2.4	U	
5	Synchronous AM	4.2.5	U	
6	Modulator performance	4.2.6	U	
7	MPX intermodulation	4.2.7	U	
8	Deviation limiting	4.2.8	U	
9	FM Signal to Noise Ratio	4.2.9	U	
10	Spurious emissions	4.2.10	U	
11	Transmitter muting during frequency shift	4.2.11	U	
12	Out-of-band emissions	4.2.12	U	

Key to columns:

Requirement:

No A unique identifier for one row of the table which may be used to identify a requirement.

Description A textual reference to the requirement.

Clause Number Identification of clause(s) defining the requirement in the present document unless another document is referenced explicitly.

Requirement Conditionality:

U/C Indicates whether the requirement is unconditionally applicable (U) or is conditional upon the manufacturer's claimed functionality of the equipment (C).

Condition Explains the conditions when the requirement is or is not applicable for a requirement which is classified "conditional".

Presumption of conformity stays valid only as long as a reference to the present document is maintained in the list published in the Official Journal of the European Union. Users of the present document should consult frequently the latest list published in the Official Journal of the European Union.

Other Union legislation may be applicable to the product(s) falling within the scope of the present document.

Annex B (normative): General measuring arrangements

B.1 Testing arrangements for antenna port measurements

B.1.1 Testing arrangement for monophonic transmitters

Figure B.1 shows the generic testing arrangement for monophonic transmitters.

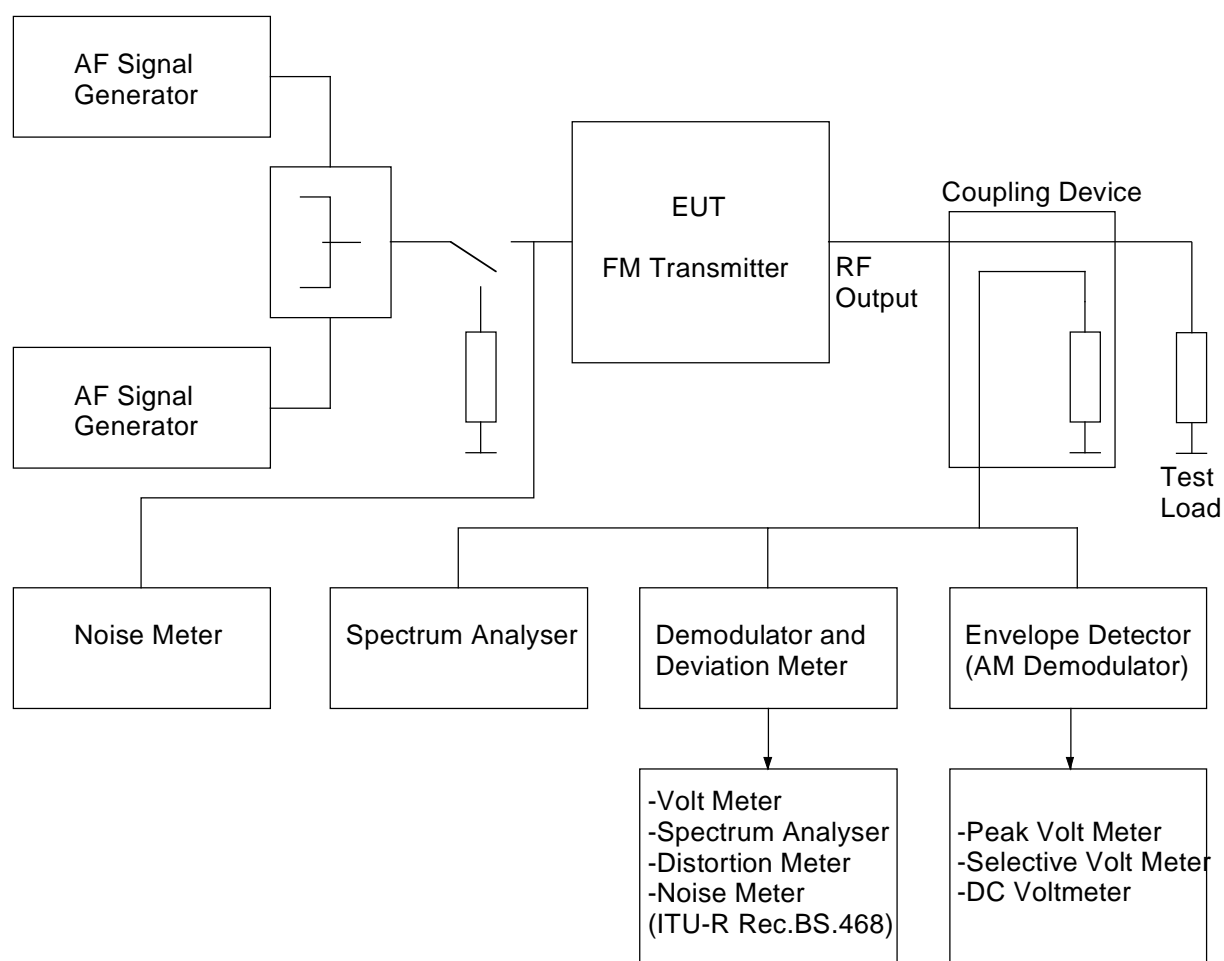
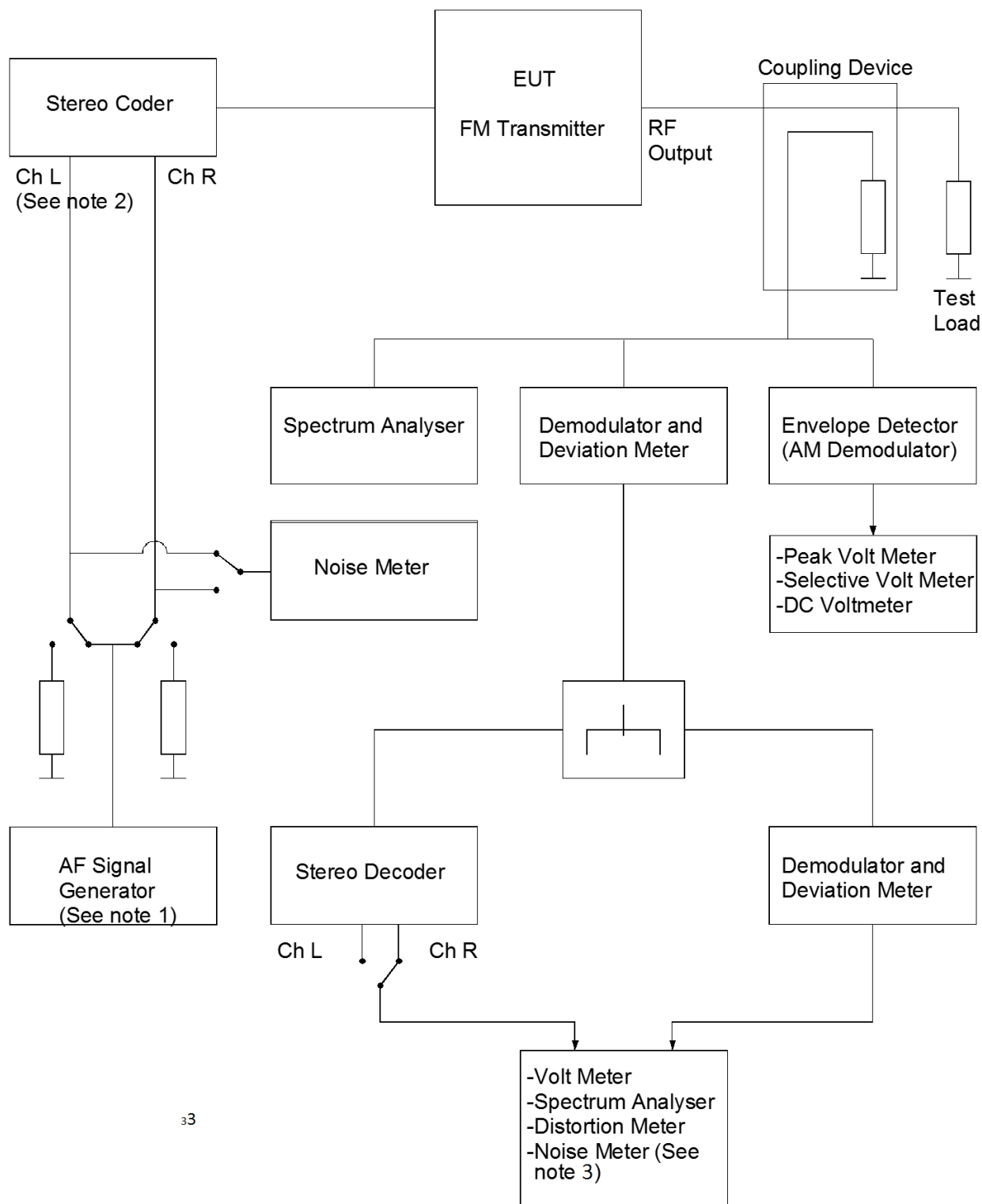

Figure B.1: Testing arrangement for monophonic transmitters

B.1.2 Testing arrangement stereophonic transmitters

Figure B.2 shows the generic testing arrangement for stereophonic transmitters.



33

NOTE 1: AF Signal Generator is replaced by coloured noise generator when is requested.

NOTE 2: Ch L = Ch R - 6dB.

NOTE 3: See Recommendation ITU-R BS.468-4 [1], clause 2.

Figure B.2: Testing arrangement for stereophonic transmitters

B.1.3 Test frequency range

Limits on unwanted emissions for radio equipment are considered to be applicable to the range 9 kHz to 300 GHz. However, for practical measurement purposes, the frequency range of spurious emissions may be restricted. As guidance for practical purposes, the following measurement parameters in table B.1 are recommended.

Table B.1: Test frequency range

Transmitter fundamental frequency range	Unwanted emission frequency measurement range	
	lower frequency	upper frequency
68 MHz to 108 MHz	9 kHz	1 GHz

The following reference bandwidths shall be used:

For spurious emissions:

- 1 kHz between 9 kHz and 150 kHz;
- 10 kHz between 150 kHz and 30 MHz;
- 100 kHz between 30 MHz and 1 GHz.

For out of band emissions:

- 1 kHz.

B.1.4 Test modulating signal

Introduction

The allocation of radio frequencies and the place of operation for broadcasting transmitters are planned such that mutual interferences as far as possible are avoided. Basis for frequency planning are the protection margin curves and the curves about propagation of RF signals in the relevant frequency range. The curves on protection margin were specified and internationally approved by ITU-R in its Recommendation ITU-R BS.412 [i.5], clause 2.

For these radio-frequency protection ratios it is assumed that the maximum peak deviation of ± 75 kHz is not exceeded. Moreover, it is assumed that the power of the complete multiplex signal (including tone and additional signals) integrated over any interval of 60 s is not higher than the power of a multiplex signal containing a single sinusoidal tone which causes a peak deviation of ± 19 kHz.

The power of a sinusoidal tone causing a peak deviation of ± 19 kHz is equal to the power of the coloured noise signal causing a quasi-peak deviation of ± 32 kHz according to Recommendation ITU-R BS.641 [i.6], annex 1.

Noise signal for modulating the signal generator

The noise is weighted in accordance with the curves shown in figure B.3.

Two conditions shall be fulfilled by the standardized signal to simulate programme modulation:

- its spectral constitution shall correspond to that of a representative broadcast programme;
- its dynamic range shall be small enough to result in a constant unequivocal reading on the instrument.

The amplitude distribution of modern dance music was taken as a basis, as it is a type of programme with a considerable proportion of high audio-frequencies, which occur most frequently. However, the dynamic range of this type of programme is too wide and does not fulfil, therefore, the second requirement mentioned above. A signal which is appropriate for this purpose is a standardized coloured noise signal, the spectral amplitude distribution of which is fairly close to that of modern dance music (see curve A of figure B.3, which is measured using one-third octave filters).

This standardized coloured noise signal may be obtained from a white-noise generator by means of a passive filter circuit as shown in figure B.4. The frequency-response characteristic of this filter is reproduced as curve B of figure B.3. It should be noted that the difference between curve A and curve B of figure B.3 is due to the fact that curve A is based on measurements with one-third octave filters which pass greater amounts of energy as the bandwidth of the filter increases with frequency.

The spectrum beyond the required bandwidth of the standardized coloured noise should be restricted by a low-pass filter having a cut-off frequency and a slope such that the bandwidth of the modulating signal is approximately equal to half the standardized bandwidth of emission. The audio-frequency amplitude/frequency characteristic of the modulating stage of the signal generator shall not vary by more than 2 dB up to the cut-off frequency of the low-pass filter.

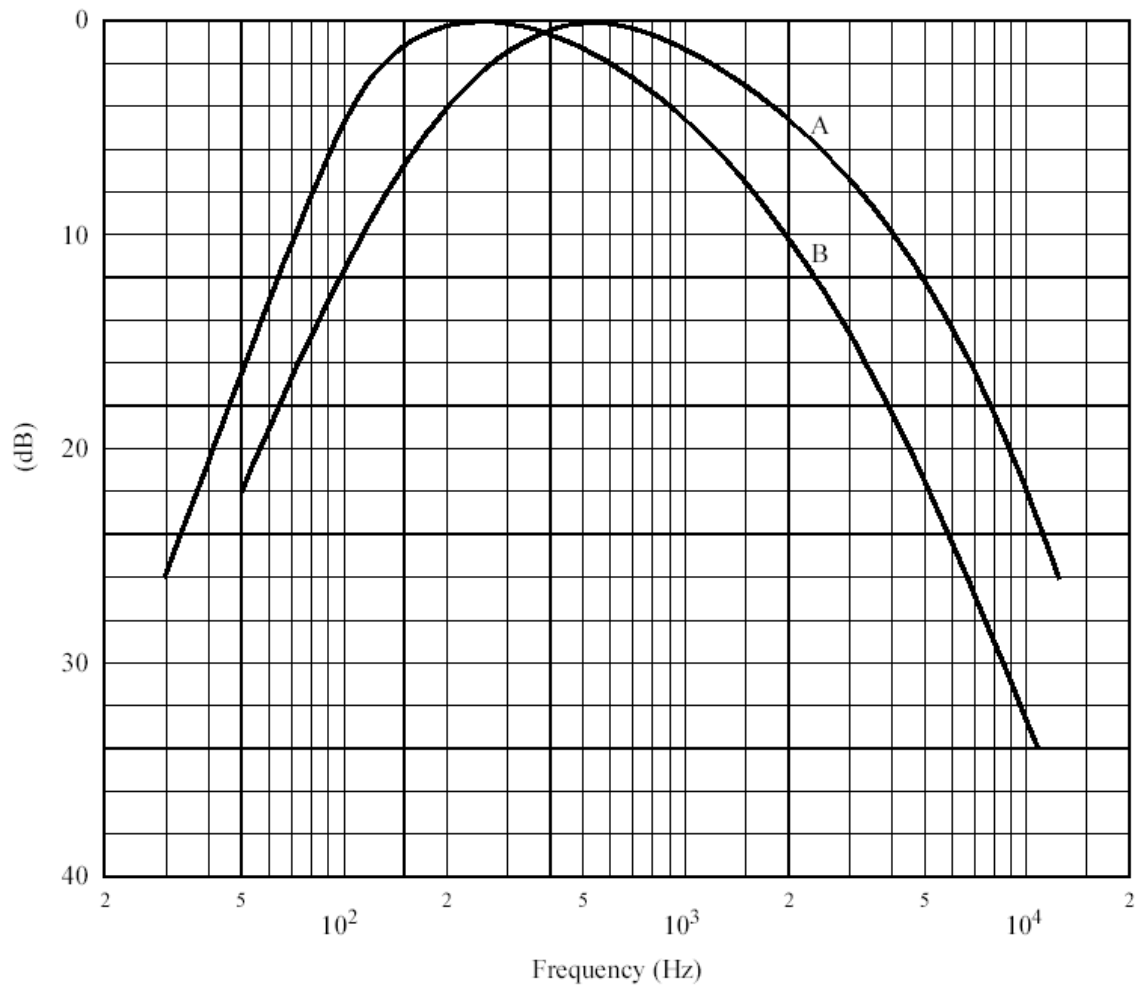

Curves A: frequency spectrum of standardized noise (measured with one-third octave filters)
 B: frequency response characteristic of filter-circuit

Figure B.3: Coloured noise modulation

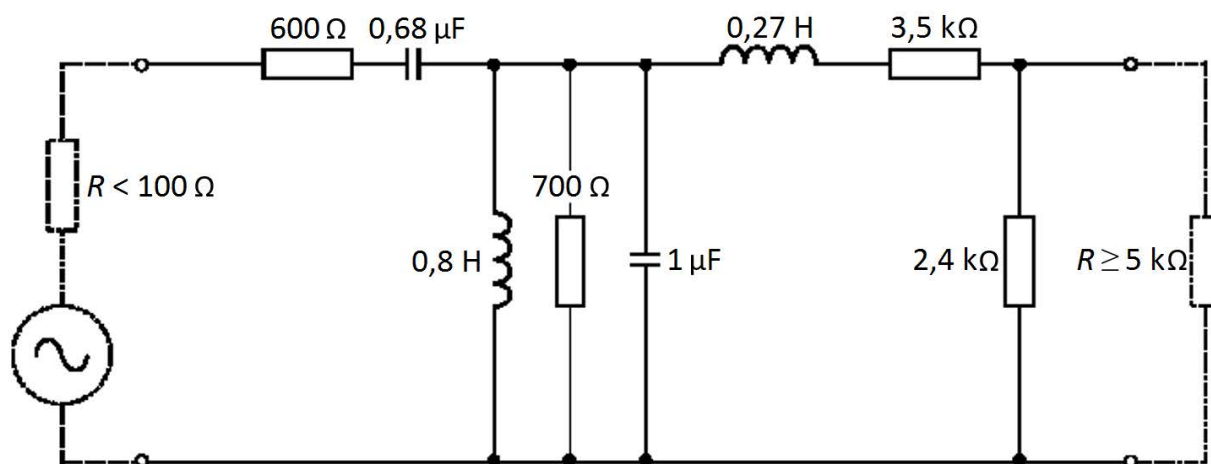

Figure B.4: Filter circuit

B.2 Test load characteristics

The transmitter may be required to operate into a precision load with return loss of $> 26 \text{ dB}$ in the frequency band in which the transmitter is designed to operate.

Annex C (informative): Change History

Version	Information about changes
2.1.1	First published version covering Directive 2014/53/EU [i.1]. Major changes are: <ul style="list-style-type: none"><li data-bbox="419 427 930 452">• Removal of cabinet radiation requirements.

History

Document history		
V1.1.1	October 2002	Publication as ETSI EN 302 018-1 and ETSI EN 302 018-2
V1.2.1	March 2006	Publication as ETSI EN 302 018-1 and ETSI EN 302 018-2
V2.0.3	December 2016	EN Approval Procedure AP 20170326: 2016-12-26 to 2017-03-27