

ETSI EN 301 997-1 V1.1.1 (2002-04)

European Standard (Telecommunications series)

**Transmission and Multiplexing (TM);
Multipoint equipment;
Radio Equipment for use
in Multimedia Wireless Systems (MWS)
in the frequency band 40,5 GHz to 43,5 GHz;
Part 1: General requirements**



Reference

DEN/TM-04097

Keywords

digital, DRRS, multimedia, multipoint, MWS,
radio, RLL

ETSI

650 Route des Lucioles
F-06921 Sophia Antipolis Cedex - FRANCE

Tel.: +33 4 92 94 42 00 Fax: +33 4 93 65 47 16

Siret N° 348 623 562 00017 - NAF 742 C
Association à but non lucratif enregistrée à la
Sous-Préfecture de Grasse (06) N° 7803/88

Important notice

Individual copies of the present document can be downloaded from:

<http://www.etsi.org>

The present document may be made available in more than one electronic version or in print. In any case of existing or perceived difference in contents between such versions, the reference version is the Portable Document Format (PDF). In case of dispute, the reference shall be the printing on ETSI printers of the PDF version kept on a specific network drive within ETSI Secretariat.

Users of the present document should be aware that the document may be subject to revision or change of status. Information on the current status of this and other ETSI documents is available at

<http://portal.etsi.org/tb/status/status.asp>

If you find errors in the present document, send your comment to:

editor@etsi.fr

Copyright Notification

No part may be reproduced except as authorized by written permission.
The copyright and the foregoing restriction extend to reproduction in all media.

© European Telecommunications Standards Institute 2002.
All rights reserved.

DECT™, **PLUGTESTS™** and **UMTS™** are Trade Marks of ETSI registered for the benefit of its Members.
TIPHON™ and the **TIPHON logo** are Trade Marks currently being registered by ETSI for the benefit of its Members.
3GPP™ is a Trade Mark of ETSI registered for the benefit of its Members and of the 3GPP Organizational Partners.

Contents

Intellectual Property Rights	5
Foreword.....	5
Introduction	5
1 Scope	6
2 References	6
3 Definitions, symbols and abbreviations	9
3.1 Definitions	9
3.2 Symbols.....	10
3.3 Abbreviations	10
4 General characteristics	11
4.1 General system architecture	11
4.2 Frequency bands and channel arrangements	12
4.2.1 Frequency plan.....	12
4.2.2 Channel arrangements.....	12
4.3 Compatibility requirements	13
4.4 Environmental conditions.....	13
4.4.1 Equipment within weather protected locations (indoor locations).....	13
4.4.2 Equipment for non-weather protected locations (outdoor locations)	13
4.5 Power supply	13
4.6 EMC conditions.....	13
4.7 Synchronization of interface bit rates	13
4.8 Antenna/feeder/branching requirements.....	14
4.8.1 Antenna requirements	14
4.8.2 Return loss	14
4.8.3 Intermodulation products	14
5 System parameters.....	14
5.1 System capacity	14
5.2 Round Trip Delay	14
5.3 Voice Coding.....	14
5.4 RF Block Diagram.....	15
5.5 Transmitter characteristics.....	15
5.5.1 Output power	15
5.5.2 Power control.....	16
5.5.2.1 Automatic Transmit Power Control (ATPC)	16
5.5.2.2 Remote Transmit Power Control (RTPC)	16
5.5.3 Remote Frequency Control (RFC).....	16
5.5.3.1 Out of block emissions caused by RFC setting	16
5.5.3.2 Emissions caused by RFC setting inside the block	16
5.5.4 RF spectrum mask	16
5.5.4.1 Channel spectrum mask	16
5.5.4.2 Transmitter block edge mask	17
5.5.5 Spurious emissions (external)	17
5.5.6 RF tolerance.....	17
5.6 Receiver characteristics	17
5.6.1 Spurious emissions (external)	17
5.7 System performances	18
6 Types of interface	18
Annex A (normative): Intra-block minimum requirements	20
A.1 Channel spectrum mask.....	20
A.2 BER as a function of Receiver input Signal Level (RSL).....	20

A.3	Co-channel interference	20
A.4	Adjacent channel interference	21
Annex B (informative):	CEPT/ERC regulatory considerations on EIRP and block edge mask	22
B.1	General considerations	22
B.2	Transmitter maximum EIRP limits	22
B.3	Transmitter EIRP spectral density block mask	23
Annex C (informative):	Matched receiver block-edge selectivity mask	25
C.1	Receiver block-edge selectivity mask	25
Annex D (informative):	Example of a method for Automatic Transmit Power Control (ATPC) in the uplink direction.....	27
History		29

Intellectual Property Rights

IPRs essential or potentially essential to the present document may have been declared to ETSI. The information pertaining to these essential IPRs, if any, is publicly available for **ETSI members and non-members**, and can be found in ETSI SR 000 314: *"Intellectual Property Rights (IPRs); Essential, or potentially Essential, IPRs notified to ETSI in respect of ETSI standards"*, which is available from the ETSI Secretariat. Latest updates are available on the ETSI Web server (<http://webapp.etsi.org/IPR/home.asp>).

Pursuant to the ETSI IPR Policy, no investigation, including IPR searches, has been carried out by ETSI. No guarantee can be given as to the existence of other IPRs not referenced in ETSI SR 000 314 (or the updates on the ETSI Web server) which are, or may be, or may become, essential to the present document.

Foreword

This European Standard (Telecommunications series) has been produced by ETSI Technical Committee Transmission and Multiplexing (TM), and is now submitted for the Vote phase of the ETSI standards Two-step Approval Procedure.

The present document is part 1 of a multi-part deliverable covering Transmission and Multiplexing (TM); Multipoint equipment; Radio Equipment for use in Multimedia Wireless Systems (MWS) in the frequency band 40,5 GHz to 43,5 GHz , as identified below:

Part 1: "General requirements";

Part 2: "Essential requirements under article 3.2 of the Directive 1999/5/EC".

Proposed national transposition dates	
Date of latest announcement of this EN (doa):	3 months after ETSI publication
Date of latest publication of new National Standard or endorsement of this EN (dop/e):	6 months after doa
Date of withdrawal of any conflicting National Standard (dow):	6 months after doa

Introduction

The 40 GHz band has been identified and designated within CEPT with a CEPT Recommendation ERC/DEC(99)15 [5] on the designation of the harmonized frequency band 40,5 GHz to 43,5 GHz for the introduction of Multimedia Wireless Systems (MWS), including MVDS. The term "Multimedia Wireless Systems" has been introduced to cater for the phenomenon of convergence between terrestrial Fixed Service (FS) and Broadcasting Service (BS) applications, whereby distributors of entertainment services (broadcasters) are wishing to provide interactive services and telecommunications operators are wishing to supply broader band two-way services to wider markets.

Multimedia Wireless Systems are wireless systems, which support information exchange of more than one type, such as text, graphics, voice, sound, image, data and video. They are also defined as terrestrial multipoint systems which have their origin in telecommunication and/or broadcasting, and which provide fixed wireless access direct to the end user for multimedia services. These MWS may offer different degrees of interactivity, including purely distribution systems, such as digital MVDS.

1 Scope

The present document specifies the minimum requirements for equipment and system parameters, including parameters necessary to plan co-existence, of MWS (Multimedia Wireless Systems) operating in the 40,5 GHz to 43,5 GHz frequency band and used for a range of applications including telecommunication and entertainment services. When MWS equipment is not intended for telecommunication purposes (e.g. for entertainment services), different requirements related to, for example, environmental conditions (see clause 4.4), power supply (see clause 4.5) and synchronization interfaces (see clause 4.7), may be applied, provided that guaranteed values of parameters necessary for co-existence with other MWS systems are met.

The present document is applicable to system and equipment parameters required to be able to plan the radio inter-operator co-existence of a number of possible solutions for implementing MWS in the 40 GHz frequency band according the CEPT/ERC regulatory frame based on CEPT Recommendation ERC/DEC(99)15 [5] and CEPT Recommendation ECC/REC 01-04 [55]. Besides specifically designed Multipoint fixed digital radio systems (FDRS) like that in the scope of ETSI Project (EP) BRAN, some other solutions, derived from standardized technology, are already documented, and include systems that align with:

- EN 300 748 [1];
- EN 301 199 [2];
- ITU-R Recommendation F.1499 [3];
- IEEE P802.16 [56].

It is likely that the frequency assignment criteria in this band will be based on "frequency blocks" according to CEPT Recommendation ECC/REC 01-04 [55], therefore the radio frequency co-ordination parameters specified in the present document may be subdivided into two categories:

- those detailed in the present document, related to the minimum requirements for frequency co-ordination of various systems deployed by an operator inside the same block of frequency. Although these are not all regarded as "essential R&TTE requirements", they are specified as ETSI "minimum voluntary parameters" for all MWS systems which will co-exist in this band. Their relationship with the "essential R&TTE requirements" will be detailed in part 2 of the present document;
- those related to adjacent "block-edge" interference control; these will be considered as "essential requirements" for the application of Directive 1999/5/EC (R&TTE Directive) [4] and detailed in part 2 of the present document.

The parameters specified in the present document apply to both FDD (both half and full duplex) and TDD systems.

2 References

The following documents contain provisions which, through reference in this text, constitute provisions of the present document.

- References are either specific (identified by date of publication and/or edition number or version number) or non-specific.
- For a specific reference, subsequent revisions do not apply.
- For a non-specific reference, the latest version applies.

- [1] ETSI EN 300 748: "Digital Video Broadcasting (DVB); Multipoint Video Distribution Systems (MVDS) at 10 GHz and above".
- [2] ETSI EN 301 199: "Digital Video Broadcasting (DVB); Interaction channel for Local Multi-point Distribution Systems (LMDS)".
- [3] ITU-R Recommendation F.1499: "Radio transmission systems for fixed broadband wireless access based on cable modem standard".

- [4] Directive 1999/5/EC of the European Parliament and of the Council of 9 March 1999 on radio equipment and telecommunications terminal equipment and the mutual recognition of their conformity (R&TTE Directive).
- [5] CEPT Recommendation ERC/DEC(99)15: "ERC Decision of 1 June 1999 on the designation of the harmonised frequency band 40.5 to 43.5 GHz for the introduction of Multimedia Wireless Systems (MWS) including Multipoint Video Distribution Systems (MVDS)".
- [6] ETSI EN 301 215-3: "Fixed Radio Systems; Point to Multipoint Antennas; Antennas for point-to-multipoint fixed radio systems in the 11 GHz to 60 GHz band; Part 3: Multipoint Multimedia Wireless system in 40,5 GHz to 43,5 GHz".
- [7] ETSI EN 300 019: "Equipment Engineering (EE); Environmental conditions and environmental tests for telecommunications equipment".
- [8] ETSI EN 300 385: "Electromagnetic compatibility and Radio spectrum Matters (ERM); ElectroMagnetic Compatibility (EMC) standard for fixed radio links and ancillary equipment".
- [9] ITU-T Recommendation G.810: "Definitions and terminology for synchronization networks".
- [10] ITU-T Recommendation G.812: "Timing requirements of slave clocks suitable for use as node clocks in synchronization networks".
- [11] ITU-T Recommendation G.823: "The control of jitter and wander within digital networks which are based on the 2 048 kbit/s hierarchy".
- [12] ITU-T Recommendation G.813: "Timing characteristics of SDH equipment slave clocks (SEC)".
- [13] ITU-T Recommendation G.825: "The control of jitter and wander within digital networks which are based on the synchronous digital hierarchy (SDH)".
- [14] ITU-T Recommendation G.703: "Physical/electrical characteristics of hierarchical digital interfaces".
- [15] ITU-T Recommendation G.131: "Control of talker echo".
- [16] ITU-T Recommendation G.711: "Pulse code modulation (PCM) of voice frequencies".
- [17] ITU-T Recommendation G.726: "40, 32, 24, 16 kbit/s adaptive differential pulse code modulation (ADPCM)".
- [18] ITU-T Recommendation G.728: "Coding of speech at 16 kbit/s using low-delay code excited linear prediction".
- [19] ITU-T Recommendation G.729: "Coding of speech at 8 kbit/s using conjugate-structure algebraic-code- excited linear-prediction (CS-ACELP)".
- [20] ITU-T Recommendation Q.552: "Transmission characteristics at 2-wire analogue interfaces of digital exchange".
- [21] ITU-T Recommendation Q.553: "Transmission characteristics at 4-wire analogue interfaces of digital exchanges".
- [22] ITU-T Recommendation V series: "Data communication over the telephone network".
- [23] ITU-T Recommendation X series: "Data networks and open system communication".
- [24] ITU-T Recommendation G.961: "Digital transmission system on metallic local lines for ISDN basic rate access".
- [25] ETSI ETS 300 012: "Integrated Services Digital Network (ISDN); Basic user-network interface; Layer 1 specification and test principles".
- [26] ETSI ETS 300 011: "Integrated Services Digital Network (ISDN); Primary rate user-network interface; Layer 1 specification and test principles".
- [27] ITU-T Recommendation G.962: "Access digital section for ISDN primary rate at 2 048 kbit/s".

- [28] ITU-T Recommendation G.707: "Network node interface for the synchronous digital hierarchy (SDH)".
- [29] ITU-T Recommendation G.964: "V-Interfaces at the digital local exchange (LE) - V5.1 Interface (Based on 2 048 kbit/s) for the support of access network (AN)".
- [30] ITU-T Recommendation G.965: "V-Interfaces at the digital local exchange (LE) - V5.2 interface (Based on 2 048 kbit/s) for the support of access network (AN)".
- [31] ITU-T Recommendation G.957: "Optical interfaces for equipments and systems relating to the synchronous digital hierarchy".
- [32] ETSI EN 300 324: "Signalling Protocols and Switching (SPS); V interfaces at the digital Local Exchange (LE); V5.1 interface for the support of Access Network (AN)".
- [33] ETSI EN 300 347: "Signalling Protocols and Switching (SPS); V interfaces at the digital Local Exchange (LE); V5.2 interface for the support of Access Network (AN)".
- [34] ETSI ETS 300 132-1: "Equipment Engineering (EE); Power supply interface at the input to telecommunications equipment; Part 1: Operated by alternating current (ac) derived from direct current (dc) sources".
- [35] ETSI EN 300 132-2: "Equipment Engineering (EE); Power supply interface at the input to telecommunications equipment; part 2: Operated by direct current (dc)".
- [36] CEPT Recommendation ERC/REC 74-01: "Spurious emissions".
- [37] EN 60950: "Safety of information technology equipment".
- [38] ITU-T Recommendation G.704: "Synchronous frame structures used at 1 544, 6 312, 2 048, 8 448 and 44 736 kbit/s hierarchical levels".
- [39] ANSI/IEEE 802.3: "Information technology - Telecommunications and information exchange between systems - Local and metropolitan area networks - Specific requirements - Part 3: Carrier Sense Multiple Access with Collision Detection (CSMA/CD) Access Method and Physical Layer Specifications".
- [40] ITU-T Recommendation G.966: "Access digital section for B-ISDN".
- [41] ITU-T Recommendation I.610: "B-ISDN operation and maintenance principles and functions".
- [42] ITU-T Recommendation I.732: "Functional characteristics of ATM equipment".
- [43] ETSI EG 202 306: "Transmission and Multiplexing (TM); Access networks for residential customers".
- [44] ETSI EN 301 390: "Fixed Radio Systems; Point-to-point and Point-to-Multipoint Systems Spurious emissions and receiver immunity at equipment/antenna port of Digital Fixed Radio Systems".
- [45] ITU-T Recommendation G.723.1: "Dual rate speech coder for multimedia communications transmitting at 5.3 and 6.3 kbit/s".
- [46] ETSI EN 301 489-1: "Electromagnetic compatibility and Radio spectrum Matters (ERM); ElectroMagnetic Compatibility (EMC) standard for radio equipment and services; Part 1: Common technical requirements".
- [47] ETSI EN 301 489-4: "Electromagnetic compatibility and Radio spectrum Matters (ERM); ElectroMagnetic Compatibility (EMC) standard for radio equipment and services; Part 4: Specific conditions for fixed radio links and ancillary equipment and services".
- [48] ITU-R Recommendation F.1399-1: "Vocabulary of terms for wireless access".
- [49] ETSI EN 301 213-1: "Fixed Radio Systems; Point-to-multipoint equipment; Point-to-multipoint digital radio systems in frequency bands in the range 24,25 GHz to 29,5 GHz using different access methods; Part 1: Basic parameters".

- [50] ETSI EN 301 213-2: "Fixed Radio Systems; Point-to-multipoint equipment; Point-to-multipoint digital radio systems in frequency bands in the range 24,25 GHz to 29,5 GHz using different access methods; part 2: Frequency Division Multiple Access (FDMA) methods".
- [51] ETSI EN 301 213-3: "Fixed Radio Systems; Point-to-multipoint equipment; Point-to-multipoint digital radio systems in frequency bands in the range 24,25 GHz to 29,5 GHz using different access methods; Part 3: Time Division Multiple Access (TDMA) methods".
- [52] ETSI EN 301 213-4: "Fixed Radio Systems; Point-to-multipoint equipment; Point-to-multipoint digital radio systems in frequency bands in the range 24,25 GHz to 29,5 GHz using different access methods; Part 4: Direct Sequence Code Division Multiple Access (DS-CDMA) methods".
- [53] ETSI EN 301 213-5: "Fixed Radio Systems; Point-to-multipoint equipment; Point-to-multipoint digital radio systems in frequency bands in the range 24,25 GHz to 29,5 GHz using different access methods; Part 5: Multi-Carrier Time Division Multiple Access (MC-TDMA) methods".
- [54] ETSI EN 301 785: "Fixed Radio Systems; Point-to-point packet data equipment; Parameters for radio systems with packet data interfaces for transmission of digital signals operating in the frequency range 7, 8, 13, 15, 18, 23, 26, 28, 32, 38, 52 to 55 GHz".
- [55] CEPT Recommendation ECC/REC 01-04: "Recommended guidelines for the accommodation and assignment of Multimedia Wireless Systems (MWS) in the frequency band 40.5 - 43.5 GHz".
- [56] IEEE P802.16: "Local and Metropolitan Area Networks - Part 16: Standard Air Interface for fixed Broadband Wireless Access Systems".
- [57] ITU-T Recommendation I.432.1: "B-ISDN user-network interface - Physical layer specification: General characteristics".
- [58] ITU-T Recommendation I.432.2: "B-ISDN user-network interface - Physical layer specification: 155 520 kbit/s and 622 080 kbit/s operation".
- [59] ITU-T Recommendation I.432.3: "B-ISDN user-network interface - Physical layer specification: 1 544 kbit/s and 2 048 kbit/s operation".
- [60] ITU-T Recommendation I.432.4: "B-ISDN user-network interface - Physical layer specification: 51 840 kbit/s operation".
- [61] ITU-T Recommendation I.432.5: "B-ISDN user-network interface - Physical layer specification: 25 600 kbit/s operation".
- [62] ITU-T Recommendation I.413: "B-ISDN user-network interface".
- [63] af-uni-0010.002: "ATM User-Network Interface (UNI) Specification".
- [64] af-phy-0040.000: "Physical Interface Specification for 25.6 Mb/s over Twisted Pair Cable".
- [65] ITU-T Recommendation G.967.1: "V-interfaces at the service node (SN): VB5.1 reference point specification".
- [66] ITU-T Recommendation G.967.2: "V-interfaces at the service node (SN): VB5.2 reference point specification".

3 Definitions, symbols and abbreviations

3.1 Definitions

For the purposes of the present document, the following terms and definitions apply:

block-edge: frequency borderline with a contiguous frequency block assigned to a different operator or not yet assigned

Full Capacity Load (FCL): defined by the maximum number of 64 kbit/s signals or the equivalent which can be transmitted and received by a single CRS within a specified RF bandwidth, fulfilling given performance and availability objectives in respect to fading conditions

frequency block: contiguous portion of spectrum within a sub-band or frequency band, typically assigned to a single operator (see ITU-R Recommendation F.1399-1)

round trip delay: defined as the sum of the delay between point SNI to UNI plus UNI to SNI in figure 1, including any repeaters as appropriate

3.2 Symbols

For the purposes of the present document, the following symbols apply:

dB	deciBel
dBm	deciBel relative to 1mW
GHz	GigaHertz
kbit/s	kilobit per second
Mbit/s	Megabit per second
MHz	MegaHertz
ms	millisecond
ppm	parts per million

3.3 Abbreviations

For the purposes of the present document, the following abbreviations apply:

ATM	Asynchronous Transfer Mode
ATPC	Automatic Transmit Power Control
BER	Bit Error Ratio
BS	Broadcasting Service
CBR	Constant Bit Rate
CCS	Central Control Station
CEPT	European Conference of Postal and Telecommunications Administrations
CER	Cell Error Ratio
ChS	Channel Separation
CRS	Central Radio Station
CS	Central Station
CW	Continuous Wave
EMC	ElectroMagnetic Compatibility
FCL	Full Capacity Load
FDD	Frequency Division Duplex
FER	Frame Error Ratio
FS	Fixed Service
ISDN	Integrated Services Digital Network
LAN	Local Area Network
LMDS	Local Multipoint Distribution System
MP	MultiPoint
MP-MP	MultiPoint-to-MultiPoint
MVDS	Multipoint Video Distribution System
MWS	Multimedia Wireless System
NNI	Network Node Interface
OJEC	Official Journal of the European Communities
pdf	power flux density
P-MP	Point-to-MultiPoint
RBER	Residual Bit-Error Ratio
RF	Radio Frequency
RFC	Remote Frequency Control
RS	Repeater Station
RSL	Receiver Signal Level
RTPC	Remote Transmit Power Control

Rx	Receiver
SDH	Synchronous Digital Hierarchy
SNI	Service Node Interface
TDD	Time Division Duplex
TE	Terminal Equipment
TS	Terminal Station
Tx	Transmitter
UNI	User Network Interface

4 General characteristics

4.1 General system architecture

Multimedia Wireless Systems have a MultiPoint (MP) topology, in which user traffic flows to and from points of connection with external networks to the user terminal equipment interface(s). The MWS may behave as an access network, a broadcast network or combine the two.

The general system architecture is shown in figure 1.

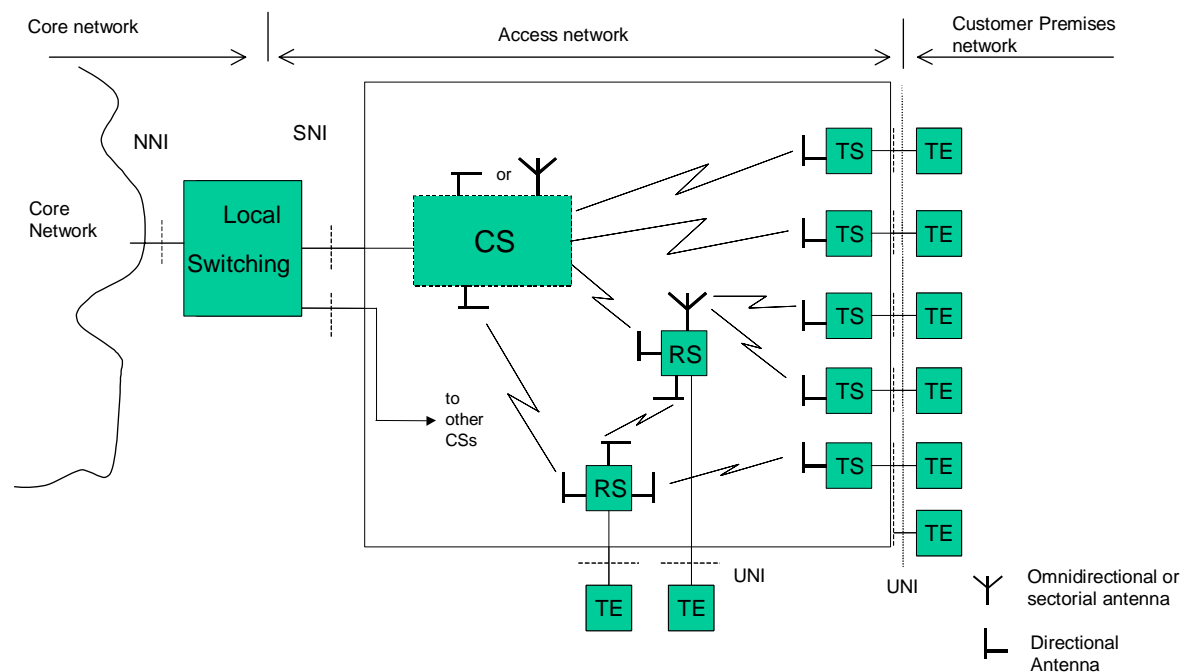

Figure 1: Reference diagram (FWA example)

Where:

- CS:** The Central Station, which interfaces the network. It can be integrated or divided into two units:
- the Central Control Station (CCS);
 - the Central Radio Station (CRS) also called the radio unit which is the central baseband/radio transceiver equipment. More than one CRS may be controlled by one CCS.
- TS:** The Terminal Station (outstations with subscriber interfaces). A TS may serve more than one Terminal Equipment (TE).
- RS:** The Repeater Station (radio repeater outstations with or without subscriber interfaces). An RS may serve one or more TS.
- TE:** Terminal Equipment.

- NNI:** Network Node Interface.
- SNI:** Service Node Interface (e.g. as described in EG 202 306 [43]).
- UNI:** User Network Interface (e.g. as described EG 202 306 [43]).

The diagram in figure 1 shows the most common and standardized approach for access network application; however when broadcast or private networks are concerned, different architectures are possible. For example the CS may be directly connected to the Core Network by means of a NNI and the switching functionality may be implemented into CS (e.g. CS is an ATM switch into an ATM network) and, for private networks, the UNI may be substituted by custom interfaces.

The reference diagram includes the system elements and interfaces for different types of MP system (both P-MP and MP-MP). Not all system elements are necessarily deployed in any particular network.

The numbers of each type of station in a real deployment can vary considerably. Figure 1 shows only each possible type of station and each possible type of connection between stations that may occur. While in P-MP applications there are typically few CS and RS connecting large number of TS, in a typical MP-MP system, there are many RS stations and a smaller number of TS stations associated with each Central Station (CS).

Although a single Central Station is possible, as shown, a typical system will deploy several Central Stations, each with connection to the SNI of the local switching centre or directly to the NNI of the core network(s). These interconnections may be by means of radio links, optical fibre or other means.

The route from a network connection point to a user's terminal equipment interface may be via a single radio path (typical for P-MP systems) or via one or more radio repeaters (typical for MP-MP systems). TS to TS connections may also be provided in some networks, not routed via an external core network.

4.2 Frequency bands and channel arrangements

4.2.1 Frequency plan

The frequency band 40,5 GHz to 43,5 GHz is identified for Multimedia Wireless Systems within Europe by CEPT Recommendation ERC/DEC(99)15 [5]. Assignments to operators are expected to be made on a frequency block basis derived from a flexible allocation frequency plan (see CEPT Recommendation ECC/REC 01-04 [55]) that will facilitate:

- both FDD and TDD systems;
- both full duplex and half duplex options;
- both symmetric and asymmetric operation;
- various equipment channel spacings.

NOTE: The radio astronomy service is also allocated primary status in the range 42,5 GHz to 43,5 GHz and hence may not be available in some Administrations for the fixed service.

4.2.2 Channel arrangements

Flexible channel arrangements are needed to accommodate the variety of requirements for MWS within the 40,5 GHz to 43,5 GHz frequency band; CEPT Recommendation ECC/REC 01-04 [55] does not regulate channel arrangement inside the assigned block of frequency. Therefore channel arrangements are not directly specified in the present document.

It is nevertheless expected that each radio system will operate on a specific channel arrangement (e.g. channel separation and centre frequencies) in order to manage, using a number of contiguous channels, the MP deployment on a given geographical area; the actual channel arrangement will be declared by the system vendor or will be found in other product-specific standards (e.g. HIPERACCESS system by EP BRAN).

Therefore, inside a single block-assignment, the network operator may, in general, subdivide the block into a number of suitable channels in order to deploy a radio network in the geographical area where the block assignment has been made.

It is required that channels close to a block edge are spaced sufficiently from the boundary to meet the block edge criteria defined by CEPT Recommendation ECC/REC 01-04 [55] and further described in annex B.

4.3 Compatibility requirements

There are no requirements for inter-operable system elements from different manufacturers.

4.4 Environmental conditions

For telecommunications applications, conditions set out in EN 300 019 [7] which defines weather protected and non-weather protected locations, classes and test severity shall apply. The manufacturer shall declare which class the equipment is designed to withstand or any guaranteed conditions.

4.4.1 Equipment within weather protected locations (indoor locations)

Equipment intended for telecommunications applications and operating within temperature controlled locations or partially temperature controlled locations shall meet the requirements of EN 300 019 [7] classes 3.1 and 3.2 respectively. Optionally, the more stringent requirements of EN 300 019 [7] classes 3.3 (non-temperature controlled locations), 3.4 (sites with heat trap) and 3.5 (sheltered locations) may be applied.

4.4.2 Equipment for non-weather protected locations (outdoor locations)

Equipment intended for telecommunications applications and operating within non-weather protected locations shall meet the requirements of EN 300 019 [7] class 4.1 or 4.1E. Class 4.1 applies to many European countries and class 4.1E applies to all European countries. For systems supplied within a specific radio cabinet which gives full protection against precipitation, wind, etc. the EN 300 019 [7] classes 3.3, 3.4 and 3.5 may be applied also for equipment intended for operation in non-weather protected locations.

4.5 Power supply

The power supply interface shall be in accordance with the characteristics of one or more of the secondary voltages foreseen in ETS 300 132-1 [34] and EN 300 132-2 [35]. For safety requirements the power supply interface shall be in accordance with EN 60950 [37].

NOTE: Some applications may require a power supply voltage range that is not covered by ETS 300 132-1 [34] and EN 300 132-2 [35].

4.6 EMC conditions

Fixed Service equipment shall operate under the conditions specified in relevant parts 1 and 4 of the EMC multipart harmonized standard EN 301 489 [46] and [47] or to the equivalent harmonized EN 300 385 [8]; both are a basis for presumption of conformity to article 3.1b of the R&TTE Directive [4], however the latter will cease this role by the date reported in the OJEC.

4.7 Synchronization of interface bit rates

Certain digital services require the system to provide synchronized interfaces at the terminal interface point (UNI in figure 1). Such systems shall include methods enabling internal and external synchronization to the network. The principles for synchronization shall be met according to ITU-T Recommendation G.810 [9]. Tolerances shall be in accordance with ITU-T Recommendations G.812 [10] and G.823 [11] for systems providing PDH interfaces and/or ITU-T Recommendations G.813 [12] and G.825 [13] for systems providing SDH interfaces.

Services that may require external synchronization interfaces are for instance CBR (Constant Bit Rate) services such as $n \times 2$ Mbit/s and $n \times 64$ kbit/s, in particular when MWS data interfaces are delivering tributaries coming from different sources.

4.8 Antenna/feeder/branching requirements

4.8.1 Antenna requirements

An MWS may employ directional, sectored and omni-directional antenna types. The choice depends on the system configuration and type of station (see figure 1). The antenna characteristics are specified in EN 301 215-3 [6].

4.8.2 Return loss

Where antennas are an integral part of the TS, RS and the CRS radio equipment, there are no requirements to be defined at reference point C'/C shown in figure 2 in the direction to the transceiver of the CRS, TS and RS respectively. When separate antennas are used the return loss referred to C'/C shall be better than 18 dB.

4.8.3 Intermodulation products

No requirement are necessary to be defined because MP systems do not generally use RF branching networks at the same antenna.

5 System parameters

5.1 System capacity

Due to the wide range of present and future services included in the MWS scope, no requirement has been identified on the system capacity.

NOTE: However, the gross-bit-rates given in the EN 301 213 series [49] to [53] for similar system type, channel separation and access methodology may be taken into account for a general informative reference.

5.2 Round Trip Delay

The round trip delay for a 64 kbit/s traffic channel carrying circuit switched telephony shall not exceed 20 ms.

Longer round trip delays may result at other bit rates and when using speech coding at rates lower than 64 kbit/s. In order to guarantee that the delay introduced by the system into the transmission network does not degrade the quality of the telephone communication, compliance to ITU-T Recommendation G.131 [15] shall be ensured.

5.3 Voice Coding

If the system provides voice services, where the voice encoding/decoding is within the system, one or more of the following coding methods should be used:

64 kbit/s:	ITU-T Recommendation G.711 [16];
32 kbit/s:	ITU-T Recommendation G.726 [17];
16 kbit/s:	ITU-T Recommendation G.728 [18];
8 kbit/s:	ITU-T Recommendation G.729 [19];
5,3 kbit/s to 6,3 kbit/s, dual rate:	ITU-T Recommendation G.723.1 [45].

Other voice coding methods may be employed if the quality for voice transmission is adequate. The coding method used shall be declared by the manufacturer.

5.4 RF Block Diagram

The RF system block diagram in figure 2 shows the point-to-point connection of a MP transceiver.

The "DATA INTERFACE" block contains the mapping functionalities required for transforming from/to packet data protocols into/from data stream suitable for RF transmission (e.g. load and access control signals for concentration into a continuous bit-rate data stream on which the system performance will be defined).

The introduction of this new block and its related reference points, X'/X (baseband interfaces) and Z'/Z (physical layer interfaces), should be used to clarify where the requested radio parameters are intended to apply. The need for this clarification is strictly connected to system testing issues (i.e. conformance testing or in field commissioning/maintenance).

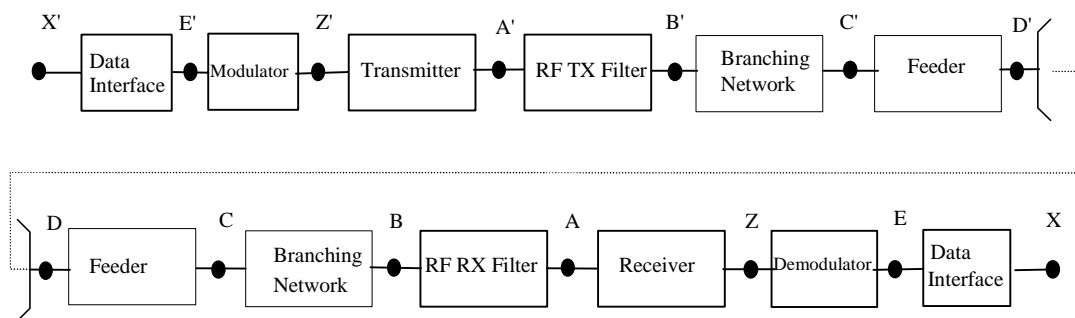

NOTE: The points shown above are reference points only; points B, C and D, B', C' and D' may coincide.

Figure 2: RF system block diagram

5.5 Transmitter characteristics

All Tx characteristics shall be independent from the system payload condition (i.e. ranging from the system completely unloaded up to the full capacity load).

The values and measurements are referred to point C' of figure 2.

Measurements shall be made when the CRS (at least one transceiver equipment) is under its full capacity load conditions to be declared by the manufacturer.

The specified Tx characteristics shall be met with the appropriate input signals applied at point E' of figure 2 and measured at point E.

5.5.1 Output power

CEPT Recommendation ECC/REC 01-04 [55] defines the maximum allowed transmitted spectral EIRP density inside the block based on the typical ranges of antenna gains and equipment power output. These limits are reported in annex B.

Regulatory authorities may require the Tx output EIRP to be reduced, in order to comply with the EIRP restrictions that may be necessary when those authorities foresee additional frequency co-ordination. In this case a means of reducing the Tx output power shall be available (e.g. fixed attenuators or RTPC) with a setting tolerance of ± 3 dB.

For testing purposes the EIRP may be evaluated as the sum of the measured power at the antenna port plus the antenna gain.

5.5.2 Power control

5.5.2.1 Automatic Transmit Power Control (ATPC)

ATPC is mandatory for TS transmitters that have a maximum Tx power density greater than 0,5 dBm/MHz. See annex D for typical implementation details.

Equipment with ATPC will be subject to manufacturer declaration of the ATPC ranges and related tolerances. When required, testing for conformance shall be carried out with output power level corresponding to:

- ATPC set manually to a fixed value for system performance;
- ATPC set at maximum provided output power for Tx spectral emissions.

5.5.2.2 Remote Transmit Power Control (RTPC)

RTPC is an optional feature. The use of the RTPC may depend on the access scheme. Equipment with RTPC will be subject to manufacturer declaration of the RTPC ranges and related tolerances. When required, testing for conformance shall be carried out with output power level corresponding to:

- RTPC set manually to the maximum and to the minimum values for system performance;
- RTPC set at maximum provided output power for Tx spectral emissions.

5.5.3 Remote Frequency Control (RFC)

RFC is an optional feature. The use of the RFC may depend on the access scheme. Equipment with RFC will be subject to manufacturer declaration of the RFC ranges and related tolerances. Testing for conformance shall be carried out for RFC setting procedure for three frequencies (i.e. frequency channel settings from lowermost to centre, centre to uppermost and back from uppermost to lowermost within the covered range). The test shall be carried out at reference climatic conditions.

5.5.3.1 Out of block emissions caused by RFC setting

In order to fulfil the essential requirements of article 3.2 of the R&TTE Directive [4], the RFC setting procedure shall not produce emissions exceeding the block edge mask (see clause 5.5.4.2).

5.5.3.2 Emissions caused by RFC setting inside the block

In addition, the setting procedure shall not produce emissions outside the previous channel centre frequency spectrum mask and new set channel centre frequency spectrum mask of the specified system (see annex A).

5.5.4 RF spectrum mask

5.5.4.1 Channel spectrum mask

In order to permit flexible channel arrangements in assigned frequency blocks, a block edge mask is specified, for regulatory purposes, in CEPT Recommendation ECC/REC 01-04 [55]. The spectrum mask of the channel(s) close to the block boundary determines the required spacing of the nearest channel centre frequency from the boundary, based on the specified requirements for out of block emissions.

However, conventional channel-based spectrum masks may still be required by operators for intra-block co-ordination. Maximum limits for the spectrum mask are reported in annex A; although those limits are purely intended as ETSI voluntary limits, part 2 of the present document details their relationship with the essential requirements under the R&TTE Directive [4].

5.5.4.2 Transmitter block edge mask

Coordination between operators in adjacent frequency blocks requires the specification of a suitable block edge mask. This is a regulatory requirement and not subject to equipment standardization. In CEPT Recommendation ECC/REC 01-04 [55], CEPT has specified a block edge mask for the 40 GHz band. This is reproduced for reader convenience in annex B.

As detailed in part 2 of the present document, the supplier shall declare, as a function of the upper EIRP limit of the system in its operational condition, the minimum channel centre frequency separation of the system from the block-edge (F_{txm} in figure B.2), inclusive of the allowance for the RF tolerance (see note). Different upper EIRP limits, when required, shall be obtained by means of permanent power settings (e.g. by fixed attenuators or by RTPC) and/or by a declared limit for the antenna gain.

NOTE: It is generally expected that, at this distance from the block edge, the corresponding Rx will already meet the "matched Rx selectivity" criteria, reported in annex C.

For any conformance-test purpose, tests should be carried out:

- at the minimum F_{txm} foreseen, with the equipment delivering the related declared upper EIRP limit;
- at the absolute maximum deliverable EIRP and related F_{txm} declared.

The tests may be carried out separately for radio equipment and antenna provided that the supplier declares the maximum antenna gain allowed for the system, in the above specified operative conditions, in order to convert the EIRP mask into a power mask.

5.5.5 Spurious emissions (external)

According to CEPT Recommendation ERC/REC 74-01 [36] and the more stringent EN 301 390 [44], the external spurious emissions are defined as emissions at frequencies which are removed from the nominal carrier frequency more than $\pm 250\%$ of the relevant channel separation; for the purpose of the present document the channel spacing is intended as the one used by the system inside the assigned block.

The limits and the practical measurement range (see note) shall be in accordance with EN 301 390 [44]. However, should the Tx block-edge mask result in more stringent requirement, it will take precedence over the spurious emission limit.

NOTE: When waveguide is used between reference point A' and D' (and/or A and D), whose length is greater than twice the free space wavelength of cut-off frequency (F_c), the lower limit of measurement will be increased to $0,7 F_c$, and to $0,9 F_c$ when the length is greater than four times the free space wavelength of F_c .

5.5.6 RF tolerance

The maximum RF tolerance shall be less than 30 ppm around the intended nominal channel centre frequency.

It shall be the responsibility of the operator to ensure that the RF tolerance does not make the equipment exceed the emission boundary of the Block Edge Mask (see clause 5.5.4.2) when operating over the full range of the declared environmental conditions (see clause 4.4).

5.6 Receiver characteristics

5.6.1 Spurious emissions (external)

The limits and the practical measurement range (see note) shall be in accordance with EN 301 390 [44]. However, should the Tx block-edge mask result in more stringent requirement, it will take precedence over the spurious emission limit.

NOTE: When waveguide is used between reference point A' and D' (and/or A and D), whose length is greater than twice the free space wavelength of cut-off frequency (F_c), the lower limit of measurement will be increased to $0,7 F_c$, and to $0,9 F_c$ when the length is greater than four times the free space wavelength of F_c .

5.7 System performances

In order to permit flexible channel arrangements in assigned frequency blocks, no further specific system performances are given.

However, conventional channel-based spectrum co-ordination parameters may still be required by operators for intra-block co-ordination. Maximum limits for those characteristics are reported in annex A; although those limits are purely intended as ETSI voluntary limits, part 2 details their relationship with the essential requirements under the R&TTE Directive [4].

6 Types of interface

Table 1 shows some common standardized interfaces and is included for information. Due to the wide range of possible MWS services, a particular system may use any (or none) of the interfaces listed here. Additional interfaces not listed here may also be applicable. Where a system interface at either the NNI or UNI in the reference diagram of figure 1 is with a recognized standard network, the system operator will require conformance with relevant standards. However, in some cases, the services provided may be novel and interfaces may not yet be specified in standards.

Table 1: Commonly used standardized interfaces

Interface	Proposed standard
TE (Subscriber Equipment) UNI Interface	
Analogue (2 wires)	ITU-T Recommendation Q.552 [20]
Analogue (4 W + E & M)	ITU-T Recommendation Q.553 [21]
Digital data port (electrical)	Digital data port (electrical) ITU-T Recommendation G.703 [14], ITU-T Recommendation X series [23] and ITU-T Recommendation V series [22]
ISDN basic rate U; S	ITU-T Recommendation G.961 [24] and ETS 300 012 [25]
ISDN primary rate U; S	ITU-T Recommendation G.962 [27] and ETS 300 011 [26]
2 Mbit/s (E1)	ITU-T Recommendation G.703 [14]
N*64 kbits/s Mbit/s (fractional E1)	ITU-T Recommendations G.703 [14] and G.704 [38]
10 Mbit/s LAN interface (Ethernet like)	ISO 8802-3/IEEE 802.3 (10 Base-T) [39]
100 Mbit/s LAN interface (Ethernet like)	ISO 8802-3/IEEE 802.3 (100 Base-T) [39]
ATM UNI 3.1	ATMF UNI 3.1 (af-uni-0010.002 [63]) ATMF 25,6 Mbit/s (af-phy-0040.000 [64])
B-ISDN UNI	ITU-T Recommendation I.432.series [57] to [61] ITU-T Recommendation I.413 [62]
Service Node Interface	
Digital data port (electrical)	Digital data port (electrical) ITU-T Recommendation G.703 [14], ITU-T Recommendation X series [23] and ITU-T Recommendation V series [22]
ISDN basic rate U; S	ITU-T Recommendation G.961 [24] and ETS 300 012 [25]
ISDN primary rate U; S	ITU-T Recommendation G.962 [27] and ETS 300 011 [26]
PDH/SDH interfaces	ITU-T Recommendations G.703 [14]; G.707 [28] and G.957 [31]
2 Mbit/s (E1)	ITU-T Recommendation G.703 [14]
N x 64 kbits/s Mbit/s (fractional E1)	ITU-T Recommendations G.703 [14] and G.704 [38]
B-ISDN	ITU-T Recommendation G.967.1 (VB5.1) [65] ITU-T Recommendation G.967.2 (VB5.2) [66]
ISDN + Analogue subscribers + Leased lines 2 Mbit/s Interface	ITU-T Recommendation G.703 [14] ITU-T Recommendation G.964 [29] ITU-T Recommendation G.965 [30] EN 300 324 [32] EN 300 347 [33]
ATM NNI	ITU-T Recommendation G.966 [40] ITU-T Recommendation I.610 [41] ITU-T Recommendation I.732 [42]
ATM UNI 3.1	ATMF UNI 3.1 (af-uni-0010.002 [63]) ATMF 25,6 Mbit/s (af-phy-0040.000 [64])

Annex A (normative): Intra-block minimum requirements

This annex summarizes other minimum "ETSI voluntary" requirements. They are defined in order to enable generic frequency co-ordination of the various channels inside an assigned block and/or to facilitate co-ordination at geographical boundaries where different operators, assigned with the same block, may need to improve co-ordination at their geographical border (e.g. specific link-by-link co-ordination). Although these limits are purely intended as ETSI voluntary limits, part 2 of the present document details their relationship with the essential requirements under the R&TTE Directive [4].

A.1 Channel spectrum mask

The spectrum masks reported in EN 301 213 series [49] to [53] related to the same system type, access method and channel separations shall be met. Systems implemented for channel separations not provided by EN 301 213 series [49] to [53] shall use a spectrum mask linearly extrapolated from that of the same system type and access method with the nearest Channel Separation (ChS); the extrapolated mask shall have corner points with the same attenuation and frequency value multiplied by a normalized factor:

$$\text{System mask corner point frequency} = \text{Nearest ChS mask corner point frequency} \left(\frac{\text{System foreseen ChS}}{\text{Nearest ChS}} \right)$$

For spectral lines exceeding the spectrum mask the same allowance given in EN 301 213 series [49] to [53] shall be used.

A.2 BER as a function of Receiver input Signal Level (RSL)

The thresholds reported in EN 301 213 series [49] to [53] related to the same system type, access method and channel separations, but relaxed by 1 dB, shall be met.

Systems implemented for channel separations not provided by EN 301 213 series [49] to [53] shall meet RSL limits extrapolated from that of the same system type and access method with the nearest ChS; the extrapolated limits will be calculated with the following formula:

$$\text{System RSL} = \text{Nearest ChS RSL} + \left(10 \log \frac{\text{System foreseen ChS}}{\text{Nearest ChS}} \right)$$

Any alternative error-ratio evaluation methods (e.g. Frame Error Ratio (FER) or Cell Error Ratio (CER)) may be used provided that the supplier gives suitable translation methodology.

NOTE: Information on FER relationship may be found in EN 301 785 [54], while CER is a conventional ATM parameter.

A.3 Co-channel interference

The same requirements reported in EN 301 213 series [49] to [53] related to the same system type, access method and channel separations shall be met.

A.4 Adjacent channel interference

The same requirements reported in EN 301 213 series [49] to [53] related to the same system type, access method and channel separations shall be met.

Annex B (informative): CEPT/ERC regulatory considerations on EIRP and block edge mask

B.1 General considerations

CEPT Recommendation ECC/REC 01-04 [55] has defined maximum allowed EIRP density and block-edge requirements suitable for deploying MWS in the 40,5 GHz to 43,5 GHz frequency band, allowing flexibility in the choice of system technology, without the need for specific co-ordination between operators assigned adjacent frequency blocks.

The concept of "matched" Tx and Rx requirements is also supported; however, while the Tx block mask concept is considered regulatory, the Rx matched requirement is considered non-essential from the regulatory point of view.

The Tx maximum EIRP spectral density limits and associated Tx EIRP spectral density block mask are reported in this annex and a matched Rx block selectivity mask is included in annex C. The Tx block mask is used to determine how close to the block edge a Tx with a particular set of characteristics can be placed. By varying the EIRP of the Tx, the frequency separation of the Tx from the block edge can be varied to optimize system design.

B.2 Transmitter maximum EIRP limits

CEPT Recommendation ECC/REC 01-04 [55] considers that maximum EIRP density is generally set by administrations in order to define power flux density (pfd) levels as a co-ordination trigger between different geographical areas or for cross-border agreements. However it introduces table B.1 giving guidance, for possible maximum limits, based on currently available technology which already takes into account an allowance for future development of higher power transmitters.

Table B.1: Maximum allowed transmitter EIRP spectral density

Station Type (see note 1)	Max EIRP spectral density (dBW/MHz) (Including tolerances and ATPC range)	Typical informative assumptions for deriving the EIRP limits (see note 2)	
		Maximum Power Spectral Density at antenna port	Maximum Antenna Gain
CS (and RS down-links)	+5	+15 dBm/MHz	20 dB
TS (and RS up-links)	+30	+15 dBm/MHz	45 dB

NOTE 1: From the point of view of applying the appropriate EIRP density and block edge mask, when MP-MP systems are considered, the mean value of the EIRP density, shown above for CS and TS, will apply. In addition, any MP-MP station providing co-frequency coverage to a defined area, without addressing any specific TS (in terms of antenna radiation pattern), should be considered as CS.

NOTE 2: In actual applications trade off in these values is possible provided that EIRP limits are met.

B.3 Transmitter EIRP spectral density block mask

The main considerations of the Tx EIRP spectral density block mask from CEPT Recommendation ECC/REC 01-04 [55], shown in figure B.1, are as follows:

- 1) A trade-off has been made between presently available Tx technology and the degree of protection against the occurrence probability of interference.
- 2) Coherence with EN 301 390 [44] requirements for spurious emissions at the antenna port.
- 3) A methodology with a decaying out-of-block emission mask to balance the conflict between narrow band and wide band systems, operating close to the block edge.
- 4) Consideration of in-block EIRP to allow for realistic antenna gain.
- 5) A "drop down corner" within the transmit block to ease the "matched" block-edge Rx selectivity, at 43 dB above the out-of-block floor.

Figure B.1 shows the block edge mask reported by CEPT Recommendation ECC/REC 01-04 [55]; the limits shown are absolute maximum and intended to include output power tolerances and any ATPC range:

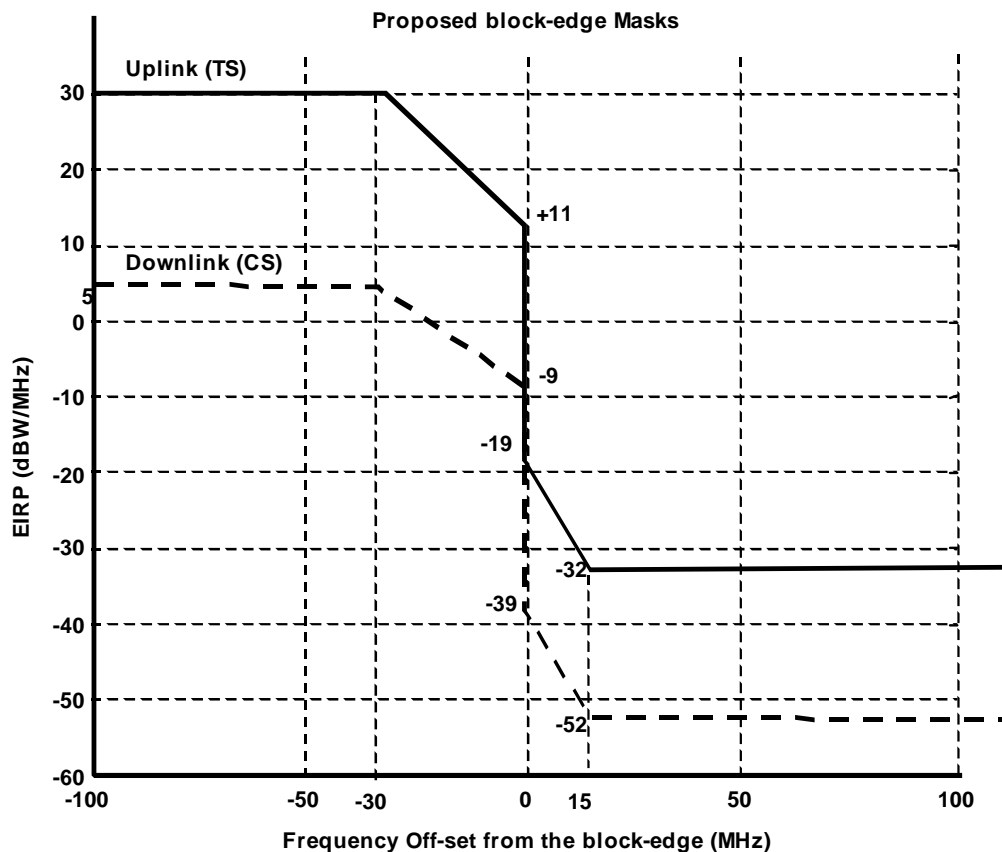

NOTE 1: The out-of-block EIRP limit shown is for wide-band/noise-like emissions and is extended to the entire 40,5 GHz to 43,5 GHz band; CW emissions are subject to the limit set by EN 301 390 [44] at the antenna port.

NOTE 2: Notwithstanding the above EIRP limits, the equipment shall meet, if resulting in more stringent requirement, the spurious emission limits set by EN 301 390 [44], referenced to the antenna port section.

Figure B.1: Block spectral density mask

The application of the mask to MP-MP systems should follow the same guidance given in note 1 to table B.1.

The necessary distance (F_{txm}) of the nearest channel centre frequency from the block edge should be determined for each type of equipment, in order to co-ordinate at the block boundary as shown in figure B.2.

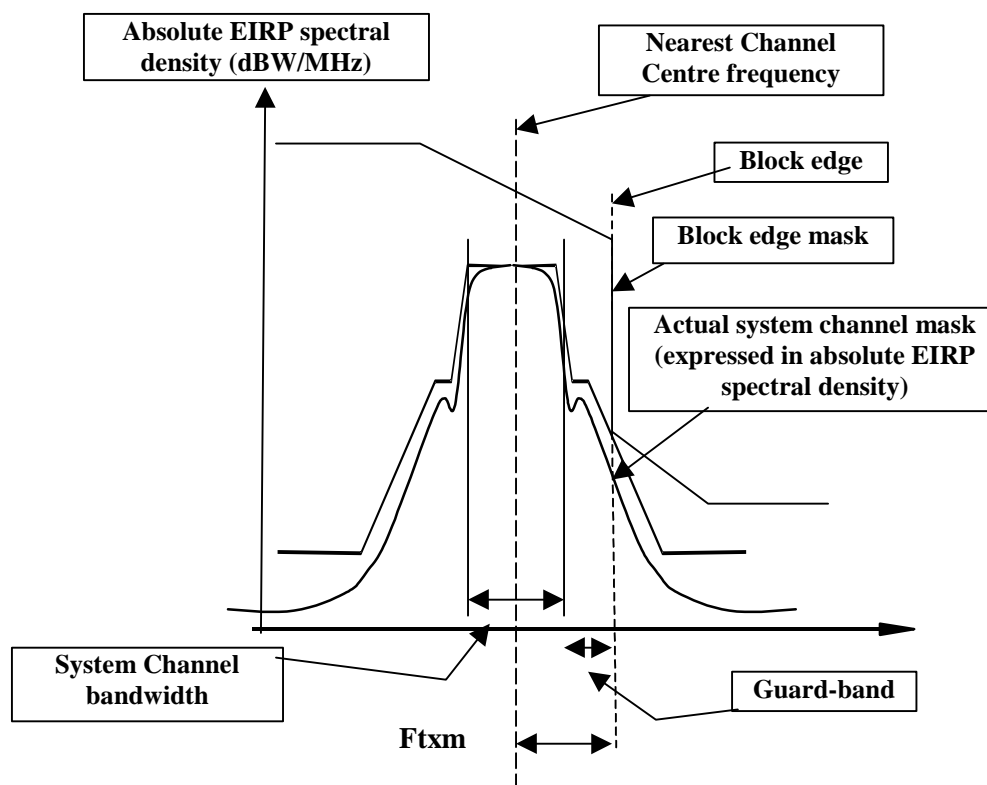

Figure B.2: System mask, block mask and block Tx guard-band relationship

For further guidance CEPT Recommendation ECC/REC 01-04 [55] reports that:

- For a sensible and cost-effective regulation, a block edge mask is generally designed on the basis of a small level of degradation in an assumed scenario with a low occurrence probability of a worst case interference (e.g. two directional antenna pointing exactly each other).
It is not therefore excluded that in a limited number of cases specific mitigation techniques might be necessary. In particular when CSs are co-located on the same building, the statistical approach is not applicable and it is assumed that common practice of site engineering (e.g. vertical decoupling) is implemented for improving antenna decoupling as much as possible.
- The 15 MHz decaying portion into the adjacent block, shown in figure B.1 will, from one side, allow wide band systems near the edge without the need of large guard band (accommodating for their 3rd order intermodulation portion) and, from the other side, will discourage any smaller band system to be placed too close to the edge (because of the higher interference level experienced by the receivers). In this way a balanced guard band will be maintained between the two adjacent blocks, independently from the actual system deployed.
- The block-edge mask is applicable also to the outermost block-edges at the boundary with adjacent allocated bands. This would guarantee, in EIRP terms, guard-bands at band edges to facilitate adjacent band inter-service co-ordination
- Moreover, for further enhancing spectrum efficiency, administrations are not expected, after the block assignment procedure, to enforce the block-edge requirements to neighbouring operators who wish to apply mutual co-ordination at the block edge in view to optimize the guard bands. In this case only the maximum "in-block" EIRP/power density apply while the "out-of-block" noise floor will apply only from a "mutually agreed" starting point within the adjacent block.

Annex C (informative): Matched receiver block-edge selectivity mask

The matched Rx block-edge selectivity mask is used to determine the smallest separation of an Rx from the block edge in order not to be affected, by any carrier in the adjacent block, more than the out-of-block limit of the emission floor provided by the Tx block-edge mask. The Rx filter response characteristic is not defined. A manufacturer is, however, recommended to declare the minimum frequency spacing from the block edge for his equipment in order to fulfil this criterion. This recommendation is not intended to affect essential parameters under article 3.2 of the R&TTE Directive [4].

C.1 Receiver block-edge selectivity mask

In order not to seek co-ordination between adjacent blocks, it is also necessary that the interference from the adjacent block is limited to the spectrum power exceeding the block-edge itself (i.e. the contribution of carriers in the adjacent block is negligible when compared to the victim receiver in-band interference caused by the out-of-block EIRP emission (see figure B.1).

For this purpose, the nearest Rx to the block edge should give, on the adjacent block signals (represented by the maximum limit of figure B.1), enough attenuation to render the interfering power density negligible in respect to the out-of-block floor emission of the mask in figure B.1. It results in a block-edge Rx selectivity shown in figure C.1.

The supplier is recommended to indicate the minimum channel centre frequency separation of the system from the block-edge (F_{rxm} in figure C.2), inclusive of the allowance for the RF tolerance of any Rx local oscillators and environmental conditions (see note). The present document is not intended to affect "essential parameters" under article 3.2 of the R&TTE Directive [4].

NOTE: It is generally expected that this distance is generally closer to the edge than that of the corresponding Tx for meeting the block-edge EIRP mask reported in annex B.

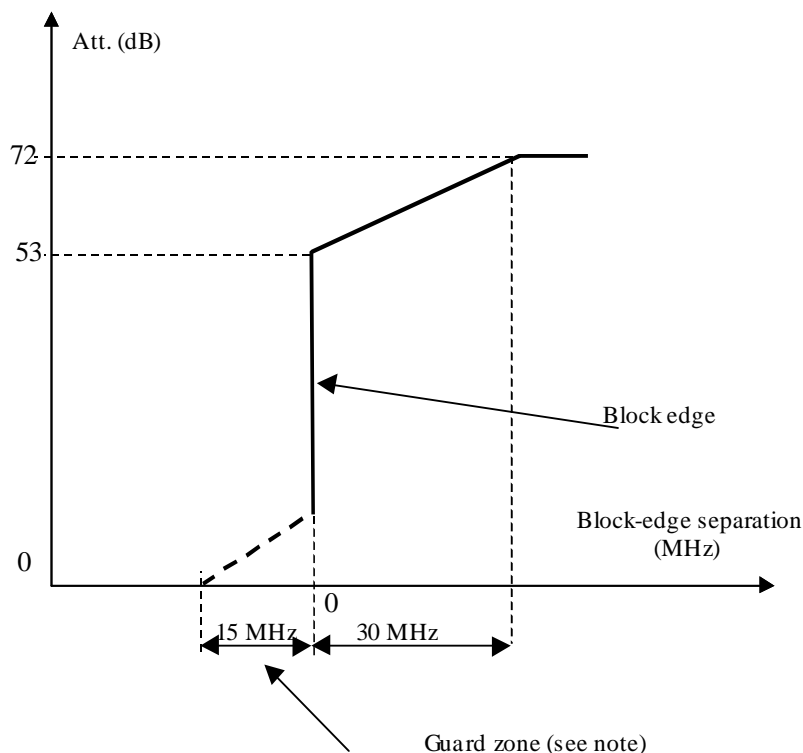

NOTE: Guard zone, in which receiver selectivity mask is not defined, but care should be taken due to higher out-of-block EIRP emission allowed by block-edge mask (see annex B).

Figure C.1: Block-edge selectivity mask for receivers

The "guard zone" in figure C.1 is defined as the part of the adjacent block within 15 MHz of the block edge. Outside this zone, the mask can be used to assess the placing of the channel centre frequency nearest to the block edge. It may be possible to place a channel centre frequency closer to the block edge (i.e. within the "guard zone") but the selectivity mask is no longer a valid means of assessing the required spacing due to the higher out-of-block emission allowed by the Tx EIRP spectral density block mask.

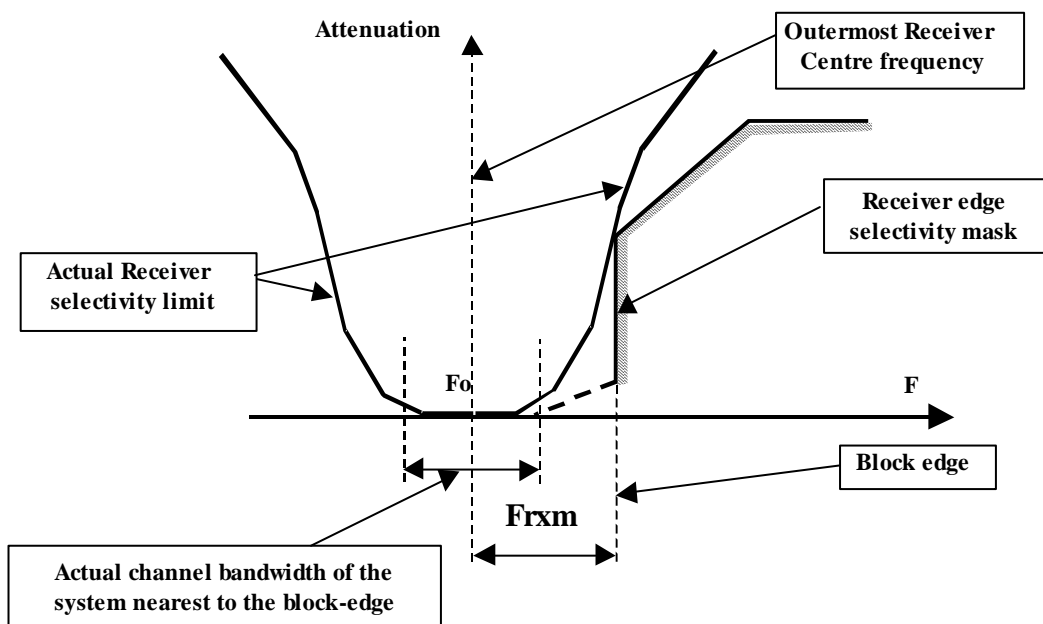

Figure C.2: System receiver mask and block-edge selectivity mask relationship

Annex D (informative): Example of a method for Automatic Transmit Power Control (ATPC) in the uplink direction

ATPC in the uplink direction (from TS to CRS) has been stated in this specification to be a mandatory requirement. It aims at automatically regulating the TS Tx power amplifier output level from an appropriate minimum, defined according to normal propagation conditions, up to the maximum transmitted power, permitted by the TS, when severe fading (rain), affecting the radio link, requires temporary power enhancements. This fair behaviour facilitates the coexistence with other MWS systems while maintaining the overall target fade margin and radio link design requirements.

One method of implementing ATPC is by means of a closed loop power control, that continuously keeps the received power level at the CRS as close as possible to a proper reference level (defined in the following paragraph). Its working principle is represented in figure D.1 for one TS.

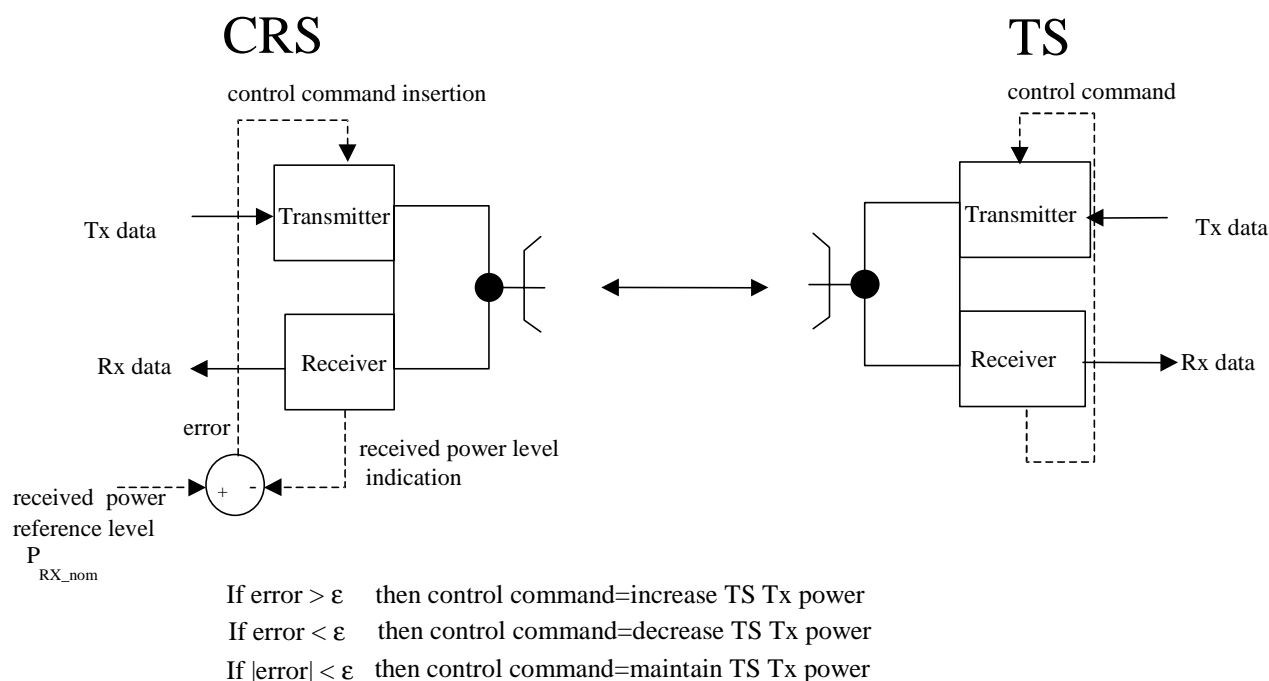

Figure D.1: Example of ATPC method

The steady state behaviour of the ATPC system is depicted in figure D.2, which also reports the main parameters used in the design of a radio link.

The right abscissa reports the variable A that indicates the supplementary attenuation (i.e. introduced by rain). The received power at CRS is reported by the ordinate in the first quadrant; under normal propagation conditions (additional propagation attenuation) the received power P_{RX_nom} ($A = 0$) depends only on known deterministic parameters (i.e. transmitted power, link distance, antennae gains, antennae misalignment losses); the ATPC loop keeps the received power level at a proper value P_{RX_nom} . Normally this operating point is set in the RBER region of the BER curve, (figure D.2). In any case, the choice of P_{RX_nom} should allow a certain nominal link margin (M_N) with regard to CRS Rx threshold P_{RX} , in order to take into account quick fading due to propagation phenomena, such as multipath and defocusing, that are not compensated as they are usually faster than the ATPC loop bandwidth. All other slow fading are compensated if their fade depth is within the ATPC operating range.

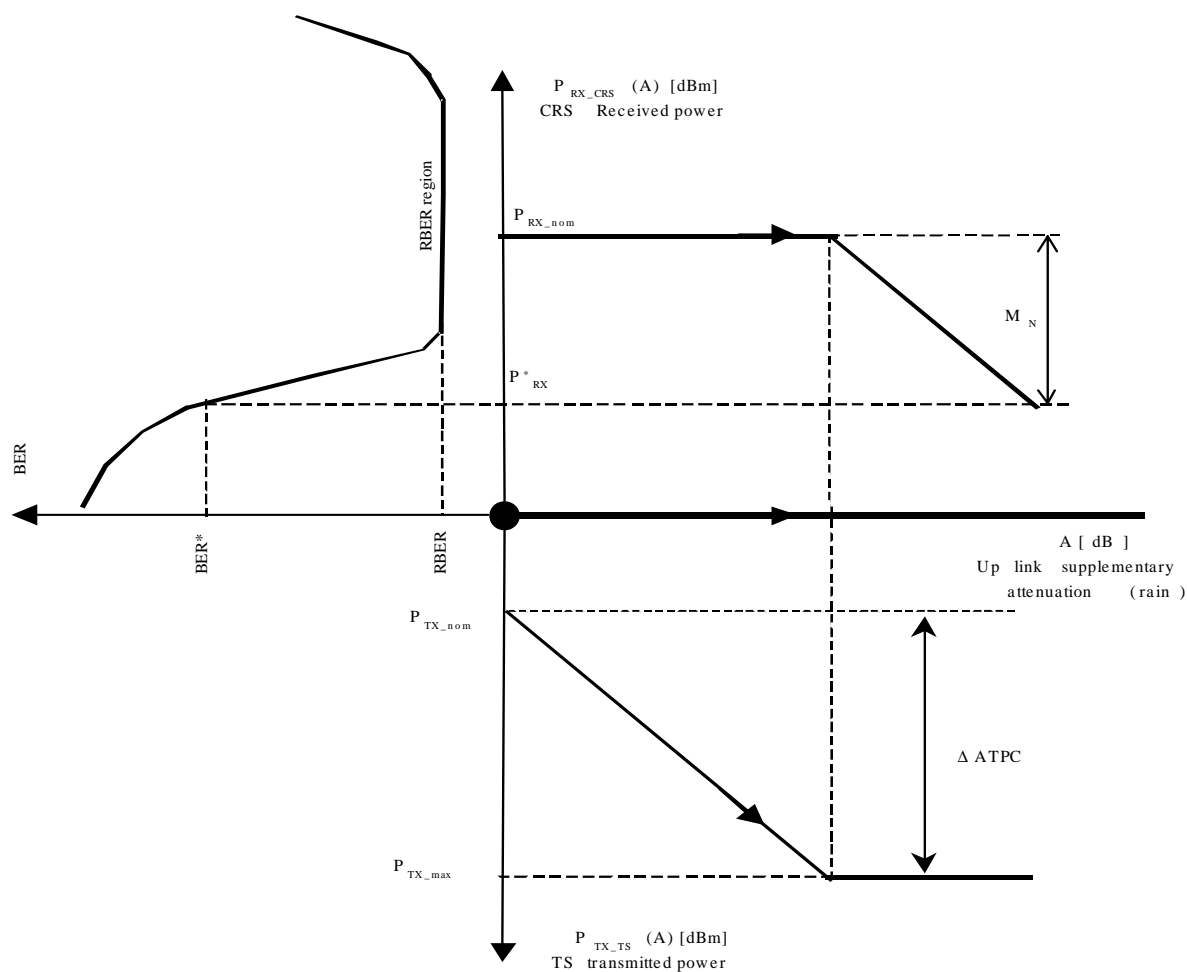

Figure D.2: Behaviour of ATPC system (example)

Moreover, P_{RX_nom} should be set in the RBER region (see figure D.2) so that system error-performance is not degraded with regard to the same system not implementing the ATPC algorithm (i.e. the same fade depth, causing BER exceeding the RBER value, occurs for the same percentage of time in both cases).

It should be also noted that the example ATPC mechanism introduced here inherently contains Remote Transmit Power Control (RTPC).

Under rain conditions, additional attenuation affects the link ($A > 0$) and so the ATPC loop automatically keeps the received power at a constant level in order to guarantee the nominal margin M_N (within the ATPC operational range).

History

Document history			
V1.1.1	October 2001	Public Enquiry	PE 20020222: 2001-10-24 to 2002-02-22
V1.1.1	April 2002	Vote	V 20020531: 2002-04-01 to 2002-05-31