

Final draft **ETSI EN 301 958** V1.1.1 (2001-12)

European Standard (Telecommunications series)

**Digital Video Broadcasting (DVB);
Interaction channel for Digital Terrestrial Television (RCT)
incorporating Multiple Access OFDM**

European Broadcasting Union



Union Européenne de Radio-Télévision



Reference

DEN/JTC-DVB-117

Keywordsbroadcasting, digital, DVB, interaction, terrestrial,
TV, video**ETSI**

650 Route des Lucioles
F-06921 Sophia Antipolis Cedex - FRANCE

Tel.: +33 4 92 94 42 00 Fax: +33 4 93 65 47 16

Siret N° 348 623 562 00017 - NAF 742 C
Association à but non lucratif enregistrée à la
Sous-Préfecture de Grasse (06) N° 7803/88

Important notice

Individual copies of the present document can be downloaded from:

<http://www.etsi.org>

The present document may be made available in more than one electronic version or in print. In any case of existing or perceived difference in contents between such versions, the reference version is the Portable Document Format (PDF). In case of dispute, the reference shall be the printing on ETSI printers of the PDF version kept on a specific network drive within ETSI Secretariat.

Users of the present document should be aware that the document may be subject to revision or change of status. Information on the current status of this and other ETSI documents is available at

<http://portal.etsi.org/tb/status/status.asp>

If you find errors in the present document, send your comment to:

editor@etsi.fr

Copyright Notification

No part may be reproduced except as authorized by written permission.
The copyright and the foregoing restriction extend to reproduction in all media.

© European Telecommunications Standards Institute 2001.
© European Broadcasting Union 2001.
All rights reserved.

Contents

Intellectual Property Rights	7
Foreword.....	7
1 Scope	8
2 References	8
3 Definitions, symbols and abbreviations	9
3.1 Definitions	9
3.2 Symbols.....	10
3.3 Abbreviations	10
4 System Architecture for Wireless DVB-T Interaction Channels	12
4.1 Protocol stack model	12
4.2 System Model.....	12
5 DVB-RCT Interaction Channel for Terrestrial Networks	14
5.1 System Concept.....	14
5.2 Lower Physical Layer principle.....	15
5.3 Forward Interaction Path (Downstream IB)	16
5.4 Return Interaction Path (Upstream).....	16
6 DVB-RCT Upstream Physical layer specifications	16
6.1 General principles.....	16
6.2 Transmission modes	18
6.3 Transmission frames.....	19
6.3.1 Transmission frames organization in the Frequency domain.....	20
6.3.2 Transmission frame organization in the Time domain.....	20
6.3.2.1 Transmission frame 1 (TF1).....	20
6.3.2.2 Transmission frame 2 (TF2).....	21
6.4 RCTT synchronization	22
6.4.1 Coarse synchronization.....	22
6.4.2 Symbol clock synchronization.....	25
6.4.3 Carrier synchronization.....	25
6.5 Signal definition	25
6.6 Transmitted signal	26
6.7 Randomization, Channel encoding and Interleaving.....	26
6.7.1 Data Randomization	27
6.7.2 Channel encoding	27
6.7.2.1 Channel encoding using Turbo codes	28
6.7.2.1.1 Turbo code permutation.....	28
6.7.2.1.2 Determination of the circulation states	29
6.7.2.1.3 Rates and puncturing map	30
6.7.2.1.4 Order of output	30
6.7.2.2 Channel encoding using concatenated codes	30
6.7.2.2.1 Reed Solomon encoding.....	30
6.7.2.2.2 Convolutional coding	31
6.7.2.2.3 Concatenated Coding.....	32
6.7.3 Interleaving	32
6.8 Modulation Schemes	33
6.8.1 Constellations	33
6.8.2 Pilot modulation.....	35
6.8.3 Ranging Pilot modulation	35
6.9 Shaping filters	36
6.9.1 The Nyquist shaping function.....	36
6.9.2 The Rectangular shaping function	37
6.10 Burst Structure and formatting	37
6.10.1 Burst Structure 1 (BS1) definition	37
6.10.1.1 Burst Structure 1 without frequency hopping	38

6.10.1.2	Burst Structure 1 with frequency hopping	39
6.10.2	Burst Structure 2 (BS2) definition	41
6.10.2.1	Carrier Allocation for Medium Access Scheme 2.....	43
6.10.2.2	Carrier Allocation for Medium Access Scheme 3.....	43
6.10.3	Burst Structure 3 (BS3) definition	44
6.11	Medium Access Schemes	45
6.11.1	Medium Access Scheme 1	45
6.11.2	Medium Access Scheme 2.....	46
6.11.3	Medium Access Scheme 3.....	46
6.11.3.1	Sub-channel format for 2K mode Structure	47
6.11.3.2	Sub-channel format for 1K mode Structure	47
6.12	Ranging signal and structures.....	48
6.12.1	Ranging Sub-Channels Definition	48
6.12.2	Ranging Sub-Channels Code Producer.....	48
6.12.3	Ranging Interval	49
6.12.4	Long Ranging transmission	49
6.12.5	Short Ranging transmission	50
6.13	Transmission capacities.....	50
6.13.1	Burst capacity and Bit Rates	50
6.13.2	Transmission frame duration	53
6.14	Modulator Performance.....	53
6.14.1	Modulator Signal performance	53
6.14.2	Modulator Switching performance	54
6.14.3	Spectrum mask.....	55
6.14.4	Time and Frequency Accuracy	56
6.14.4.1	Frequency accuracy.....	56
6.14.4.2	Time accuracy	56
7	Forward Interaction Path Specification	57
7.1	Downstream General Format	57
7.2	Upstream Synchronization Field Format.....	59
7.3	RCTT synchronization procedure	59
7.3.1	Overall Events Sequencing	60
7.3.1.1	Initial synchronization procedure.....	60
7.3.1.2	Ranging synchronization procedure.....	60
8	DVB-RCT MAC layer specifications	61
8.1	MAC Reference Model	61
8.1.1	MAC Concept.....	61
8.1.1.1	Relationship Between Higher Layers and MAC Protocol.....	61
8.1.1.2	Relationship Between Physical Layer and MAC Protocol.....	62
8.1.1.3	Relationship Between Physical Layer Slot Position Counter and MAC Slot Assignment.....	63
8.1.1.4	Timing relationship between upstream and downstream MAC Messages.....	63
8.1.2	Access Modes (Contention/Ranging/Fixed rate/Reservation)	63
8.2	Overview of Cell Configurations for DVB-RCT	65
8.2.1	RCTT's Initialization and Sign On procedure.....	66
8.3	Upstream Message Format	67
8.4	Downstream Message Format	67
8.4.1	MAC Message Format.....	67
8.4.2	MAC Initialization and Provisioning.....	70
8.4.2.1	<MAC> Provisioning Channel Message (Broadcast Downstream).....	70
8.4.2.2	<MAC> Default Configuration Message (Broadcast Downstream)	71
8.4.3	Sign On and Calibration	77
8.4.3.1	<MAC> Ranging and Power Calibration Message (Broadcast/Singlecast Downstream).....	78
8.4.3.2	<MAC> Sign-On Message (Singlecast Upstream)	81
8.4.3.3	<MAC> Initialization Complete Message (Singlecast Downstream)	82
8.4.3.4	<MAC> Slot State message (Broadcast Downstream)	83
8.4.4	Connection Establishment	85
8.4.4.1	Establishment of the First (Initial) Connection	85
8.4.4.2	<MAC> Connect Message (Singlecast Downstream).....	86
8.4.4.3	<MAC> Connect Response (Upstream Contention or Reserved).....	91
8.4.4.4	<MAC> Connect Confirm (Singlecast Downstream)	91

8.4.4.5	Establishment of Additional Connections	91
8.4.4.6	<MAC> Resource Request Message (Upstream)	92
8.4.4.7	<MAC> Resource Request Denied Message (Singlecast Downstream)	93
8.4.5	Connection Release	93
8.4.5.1	<MAC> Release Message (Singlecast Downstream)	94
8.4.5.2	<MAC> Release Response (Upstream contention or reserved)	94
8.4.6	Fixed Rate Access	94
8.4.7	Contention Based Access	95
8.4.8	Reservation Access	95
8.4.8.1	<MAC> Reservation ID Assignment Message (Singlecast Downstream)	96
8.4.8.2	<MAC> Reservation ID Response Message (Upstream contention or reserved)	97
8.4.8.3	<MAC> Reservation Request Message (Upstream contention or reserved)	97
8.4.8.3.1	<MAC> Reservation Grant Message (Broadcast Downstream)	98
8.4.8.4	<MAC> Reservation Status Request (Upstream contention or reserved)	100
8.4.9	MAC Link Management	100
8.4.9.1	Power and Timing Management	100
8.4.9.2	TFDMA Allocation Management	100
8.4.9.3	<MAC> Reprovision Message (Singlecast Downstream)	101
8.4.9.4	Channel Error Management	102
8.4.9.5	<MAC> Idle Message (Upstream contention or reserved)	103
8.4.9.6	Link Management Messages	103
8.4.9.7	<MAC> Transmission Control Message (Singlecast or Broadcast Downstream)	106
8.4.9.8	<MAC> Link Management Response Message (Upstream contention or reserved)	109
8.4.9.9	<MAC> Status Request Message (Downstream Singlecast)	109
8.4.9.10	<MAC> Status Response Message (Upstream Contention or reserved)	110
8.4.9.11	<MAC> US_Contention_Optimized_Transmission_Window_Message	112
8.5	Security (optional)	112
8.5.1	Cryptographic primitives	113
8.5.1.1	Public key exchange	113
8.5.1.2	Hashing	114
8.5.1.3	Encryption	114
8.5.1.4	Pseudo-random numbers	114
8.5.2	Main Key Exchange, MKE	115
8.5.3	Quick Key Exchange, QKE	115
8.5.4	Explicit Key Exchange, EKE	116
8.5.5	Key derivation	116
8.5.6	Data stream processing	116
8.5.6.1	Payload streams	116
8.5.6.2	Data encryption	117
8.5.6.3	Encryption flags	117
8.5.6.4	Chaining and initialization vector	117
8.5.7	Security Establishment	118
8.5.8	Persistent state variables	118
8.5.8.1	Guaranteed delivery	119
8.5.9	Security MAC Messages	119
8.5.9.1	<MAC>Security Sign-On (Single-cast Downstream)	119
8.5.9.2	<MAC>Security Sign-On Response (Upstream)	120
8.5.9.3	<MAC>Main Key Exchange (Single-cast Downstream)	121
8.5.9.4	<MAC>Main Key Exchange Response (Upstream)	121
8.5.9.5	<MAC>Quick Key Exchange (Single-cast Downstream)	122
8.5.9.6	<MAC>Quick Key Exchange Response (Upstream)	122
8.5.9.7	<MAC>Explicit Key Exchange (Single-cast Downstream)	123
8.5.9.8	<MAC>Explicit Key Exchange Response (Upstream)	123
8.5.9.9	<MAC>Wait (Upstream)	124
8.6	MAC Primitives	124
8.7	Control and Resource Primitives	125
8.7.1	On RCTT side	125
8.7.1.1	<Prim> MAC_ACTIVATION_REQ	125
8.7.1.2	<Prim> MAC_ACTIVATION_CNF	126
8.7.1.3	<Prim> MAC_CONNECT_IND	127
8.7.1.4	<Prim>MAC_RSV_ID_IND	129
8.7.1.5	<Prim> MAC_RELEASE_IND	129

8.7.1.6	<Prim> MAC_RESOURCE_REQ.....	129
8.7.1.7	<Prim>MAC_RESOURCE_CNF.....	131
8.7.1.8	<Prim>MAC_RESOURCE_DENIED_IND.....	131
8.7.2	On INA side.....	131
8.7.2.1	<Prim> MAC_INA_RESOURCE_REQ.....	131
8.7.2.2	<Prim> MAC_INA_RESOURCE_IND	133
8.8	Data Primitives	134
8.8.1	<Prim> DL_DATA_IND.....	134
8.8.2	<Prim> DL_DATA_REQ.....	135
8.8.3	<Prim> DL_DATA_CONF	135
8.9	Example MAC Control Scenarios (Informative).....	136
8.9.1	Example MAC Control Scenario on RCTT Side.....	136
8.9.2	Example Resource Management Scenario on RCTT Side.....	137
8.9.3	Example Resource Management Scenario on INA Side.....	137
8.9.4	Example Upstream Data Transfer Scenarios	138
Annex A (informative): Compatibility issues, Frequency allocation, Frequency range		139
A.1	Strategies for gaining Access to Spectrum for DVB-RCT.....	139
A.2	Preliminary considerations on frequency allocation	139
A.3	Possible Allocation Mechanisms.....	140
A.4	Compatibility issues	141
A.4.1	Compatibility at the user side.....	141
A.4.2	Duplexer	141
Annex B (informative): Return Channel RF Link budgets and service ranges		144
Annex C (informative): TV reception/RCT Txm arrangements.....		147
Annex D (informative): Structure and specification of the RCTT's RF stage.....		150
Annex E (informative): MAC Specification and Description Language (SDL)		151
Annex F (informative): Bibliography.....		160
History		161

Intellectual Property Rights

IPRs essential or potentially essential to the present document may have been declared to ETSI. The information pertaining to these essential IPRs, if any, is publicly available for **ETSI members and non-members**, and can be found in ETSI SR 000 314: "*Intellectual Property Rights (IPRs); Essential, or potentially Essential, IPRs notified to ETSI in respect of ETSI standards*", which is available from the ETSI Secretariat. Latest updates are available on the ETSI Web server (<http://webapp.etsi.org/IPR/home.asp>).

Pursuant to the ETSI IPR Policy, no investigation, including IPR searches, has been carried out by ETSI. No guarantee can be given as to the existence of other IPRs not referenced in ETSI SR 000 314 (or the updates on the ETSI Web server) which are, or may be, or may become, essential to the present document.

Foreword

This European Standard (Telecommunications series) has been produced by the Joint Technical Committee (JTC) Broadcast of the European Broadcasting Union (EBU), Comité Européen de Normalisation ELEctrotechnique (CENELEC) and the European Telecommunications Standards Institute (ETSI), and is now submitted for the Vote phase of the ETSI standards Two-step Approval Procedure.

NOTE: The EBU/ETSI JTC Broadcast was established in 1990 to co-ordinate the drafting of standards in the specific field of broadcasting and related fields. Since 1995 the JTC Broadcast became a tripartite body by including in the Memorandum of Understanding also CENELEC, which is responsible for the standardization of radio and television receivers. The EBU is a professional association of broadcasting organizations whose work includes the co-ordination of its members' activities in the technical, legal, programme-making and programme-exchange domains. The EBU has active members in about 60 countries in the European broadcasting area; its headquarters is in Geneva.

European Broadcasting Union
CH-1218 GRAND SACONNEX (Geneva)
Switzerland
Tel: +41 22 717 21 11
Fax: +41 22 717 24 81

Founded in September 1993, the DVB Project is a market-led consortium of public and private sector organizations in the television industry. Its aim is to establish the framework for the introduction of MPEG-2 based digital television services. Now comprising over 200 organizations from more than 25 countries around the world, DVB fosters market-led systems, which meet the real needs, and economic circumstances, of the consumer electronics and the broadcast industry.

Proposed national transposition dates	
Date of latest announcement of this EN (doa):	3 months after ETSI publication
Date of latest publication of new National Standard or endorsement of this EN (dop/e):	6 months after doa
Date of withdrawal of any conflicting National Standard (dow):	6 months after doa

1 Scope

The present document is the baseline specification for the provision of the interaction channel for digital terrestrial television distribution system, DVB-T defined in the EN 300 744 standard [1].

The present document:

- gives a general description of the baseline system for interactive digital terrestrial TV;
- specifies the channel coding/modulation;
- specifies the medium access control protocol;
- provides guidelines on the radio frequency spectrum management.

The purpose of the MAC section is to redefine a set of MAC messages based on the DVB-RCCL MAC message set, adapted to suit the specific characteristics of the physical layer of the DVB-RCT specification.

The solution provided in the present document for return channels through terrestrial broadcast systems is part of a wider set of alternatives for implementing interactive services for DVB systems.

2 References

The following documents contain provisions which, through reference in this text, constitute provisions of the present document.

- References are either specific (identified by date of publication and/or edition number or version number) or non-specific.
- For a specific reference, subsequent revisions do not apply.
- For a non-specific reference, the latest version applies.

- [1] ETSI EN 300 744: "Digital Video Broadcasting (DVB); Framing structure, channel coding and modulation for Digital Terrestrial Television".
- [2] ITU-T Recommendation I.361: "B-ISDN ATM layer specification".
- [3] ITU-T Recommendation I.363: "B-ISDN ATM Adaptation Layer specification".
- [4] IETF RFC 2104: "HMAC: Keyed-Hashing for Message Authentication".
- [5] ETSI EN 301 192: "Digital Video Broadcasting (DVB); DVB specification for data broadcasting".
- [6] IETF RFC 951: "Bootstrap Protocol".
- [7] ITU-T Recommendation Z.120: "Message sequence chart (MSC)".
- [8] ISO/IEC 13818-1: "Information technology - Generic coding of moving pictures and associated audio information: Systems".

3 Definitions, symbols and abbreviations

3.1 Definitions

For the purposes of the present document, the following terms and definitions apply:

burst structure: arrangement, in time and frequency, of symbols used to transmit the basic container of 144 symbols

NOTE: It contains data symbols, pilot symbols and Nyquist symbols if needed. There are three possible Burst Structures (BS1, BS2, BS3).

cell: geographical area made up of one or more cell sectors

cell sector: geographical area covered by one or more DVB-T downstream transmitters with one or more upstream channels controlled by one or more Base Station(s) (INAs)

contention access: used by the RCTT to transmit a MAC message to the Base Station, using a slot unallocated to any RCTT

NOTE: Then, several RCTT can try to access the same slot at the same time.

medium access scheme: particular mapping of one or more Burst Structures onto a transmission frame

ranging sub-channel: set of carriers used to transmit Ranging Codes

ranging sub-channel number: number identifying a specific Ranging Sub-Channel

ranging access: used by the NIU in order to synchronize in time and power with the INA

NOTE: This is done in specific ranging slots.

slot: basic unit of allocation with 144 data symbols in time and in frequency (allowing a multiple or sub-multiple of ATM cell)

NOTE: A time slot number and a sub-channel number determine it.

sub-channel: set of carriers used to transmit an Upstream Burst Structure

NOTE: The number of carriers used in a Sub-Channel is depending on the Burst Structure (BS1, BS2, BS3).

sub-channel number: number identifying a specific Sub-Channel

time slot: elementary time unit for allocation of a slot

time slot number: sequential number of the time slot

transmission frame: organization of the Upstream RF channel, repeated cyclically

NOTE: Two types of transmission frames are defined to provide the Base Station with the tools for ranging, data reception and system synchronization.

upstream channel: set of carriers (2K or 1K) that constitutes an upstream DVB-RCT link

NOTE: Several upstream channels can be defined inside a Cell.

3.2 Symbols

For the purposes of the present document, the following symbols apply:

a % b	a modulo b
#I	number I
a and= b	test a and b equal b ?
a == b	test a equal b ?
andand	logical and
	logical or
a = b	affectation of the value b to a
a++	increment of a

3.3 Abbreviations

For the purposes of the present document, the following abbreviations apply:

AAL5	ATM Adaption Layer 5
ATM	Asynchronous Transfer Mode
BB	Base Band
BC	Broadcast Channel
BIM	Broadcast Interface Module
BNA	Broadcast Network Adapter
BO	Back-Off
BS	Burst Structure
BS1	Burst Structure 1
BS2	Burst Structure 2
BS3	Burst Structure 3
C/N	Carrier over Noise ratio
CBC	Cipher Block Chaining
CBD	Connection Block Descriptor
CC	Concatenated Code
Connection ID	Connection Identifier
CRC	Cyclic Redundancy Check
DC	Direct Current
DES	Data Encryption Standard
DS	Down-Stream
DVB	Digital Video Broadcasting
DVB-T	Digital Video Broadcasting-Terrestrial
EKE	Explicit Key Exchange
FD	Frequency Division
FDD	Frequency Division Duplex
FDMA	Frequency Division Multiple Access
FFT	Fast Fourier Transform
GFC	Generic Flow Control
GSM	Global System for Mobile
HMAC	Hash-based Message Authentication Code
IB	In-Band
IC	Interaction Channel
ICS	Inter-Carrier Spacing
ID	IDentifier
IF	Intermediate Frequency
IIM	Interaction Interface Module
INA	Interactive Network Adapter
IP	Internet Protocol
ISDN	Integrated Services Digital Network
IV	Initialization Vector
LLC	Logical Link Control
lsb	least significant bit
MAC	Medium Access Control
MAS	Medium Access Scheme

MAS1	Medium Access Scheme 1
MAS2	Medium Access Scheme 2
MAS3	Medium Access Scheme 3
MKE	Main Key Exchange
MPEG	Moving Pictures Experts Group
msb	most significant bit
MSC	Message Sequence Chart [7]
NIU	Network Interface Unit
NSAP	Network Service Access Point
OFDM	Orthogonal Frequency Division Multiplexing
OSI	Open Systems Interconnection
OTP	Operational Transmission Power
PDU	Protocol Data Unit
PHY	PHYSical layer
PID	Programme IDentifier [8]
PPP	Point-to-Point Protocol
PRBS	Pseudo-Random Binary Sequence
Prg	Programme
PRNG	Pseudo-Random Number Generator
PSTN	Public Switched Telephone Network
QAM	Quadrature Amplitude Modulation
QKE	Quick Key Exchange
QoS	Quality of Service
QPSK	Quaternary Phase Shift Keying
RCCL	Return Channel-Cable and LMDS
RCT	Return Channel Terrestrial
RCTT	Return Channel Terrestrial Terminal
Reservation ID	Reservation IDentifier
RF	Radio Frequency
RS	Reed Solomon
Rx	Receiver
SCN	Sub-Channel Number
SDL	Specification and Description Language
SMATV	Satellite Master Antenna TeleVision
STB	Set Top Box
STU	Set Top Unit
TD	Time Division
TDMA	Time Division Multiple Access
TPS	Transmission Parameter Signalling
TS	Transport Stream
Tx	Transmitter
UHF	Ultra High Frequency
US	Up-Stream
VCI	ATM Virtual Channel Identification [2]
VHF	Very High Frequency
VPI	ATM Virtual Path Identification [2]
VSWR	Voltage Standing Wave Ratio

4 System Architecture for Wireless DVB-T Interaction Channels

4.1 Protocol stack model

For asymmetric interactive services supporting broadcast to the home with a return channel, a simple communications model consists of the following layers:

- **physical layer:** defines all the physical (electrical) transmission parameters;
- **transport layer:** defines all the relevant data structures and communication protocols like data containers, etc.;
- **application layer:** is the interactive application software and runtime environments (e.g. home shopping application, script interpreter, etc.).

A simplified model of the OSI layers was adopted to facilitate the production of specifications for these layers.

Figure 1 points out the lower layers of the simplified model and identifies some of the key parameters for the lower two layers.

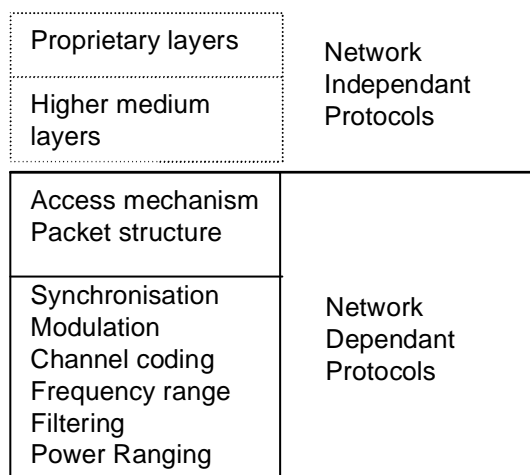

Figure 1: Layer structure for generic system reference model

The present document addresses the terrestrial interactive Network Dependant Protocols aspects only. No attempt is made to consider higher layers.

4.2 System Model

Figure 2 shows the generic system model, which has to be used within DVB for interactive services. In this system model, two channels are established between the Service provider and the User:

- **Broadcast channel (BC):** a unidirectional broadband Broadcast Channel including video, audio and data is established from the service provider to the users;
- **Interaction channel (IC):** a Bi-directional Interaction Channel is established between the service provider and the user for interaction purposes. It is formed by:
 - **Return Interaction path:** from the User to the Service Provider, it is used to make requests to the service provider, to answer questions or to upload data;
 - **Forward Interaction path:** from the Service Provider to the User, it is used to provide information and any other required communication for the interactive service provision.

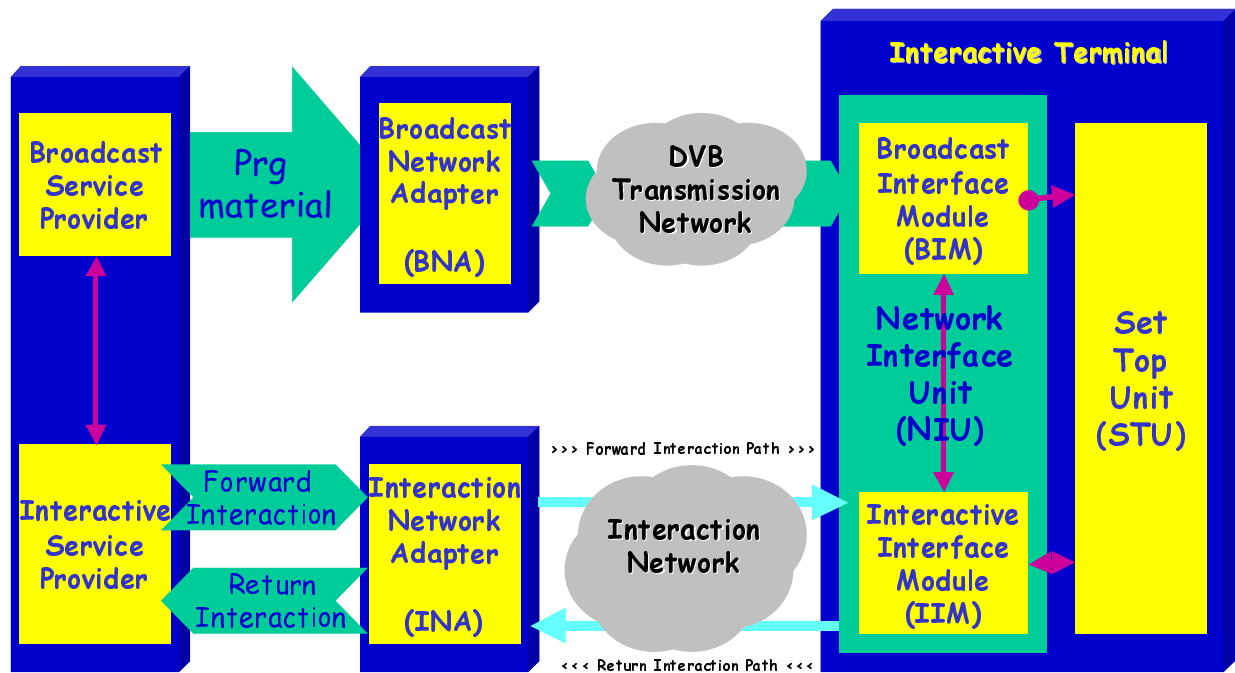

Figure 2: A generic system Reference Model for Interactive Systems

In the context of the Terrestrial Interactive networks, the Forward Interaction path is embedded in the Broadcast Channel as depicted in figure 3. As a consequence, the Terrestrial Interactive networks make use of two unidirectional physical layers, implementing a downstream and an upstream.

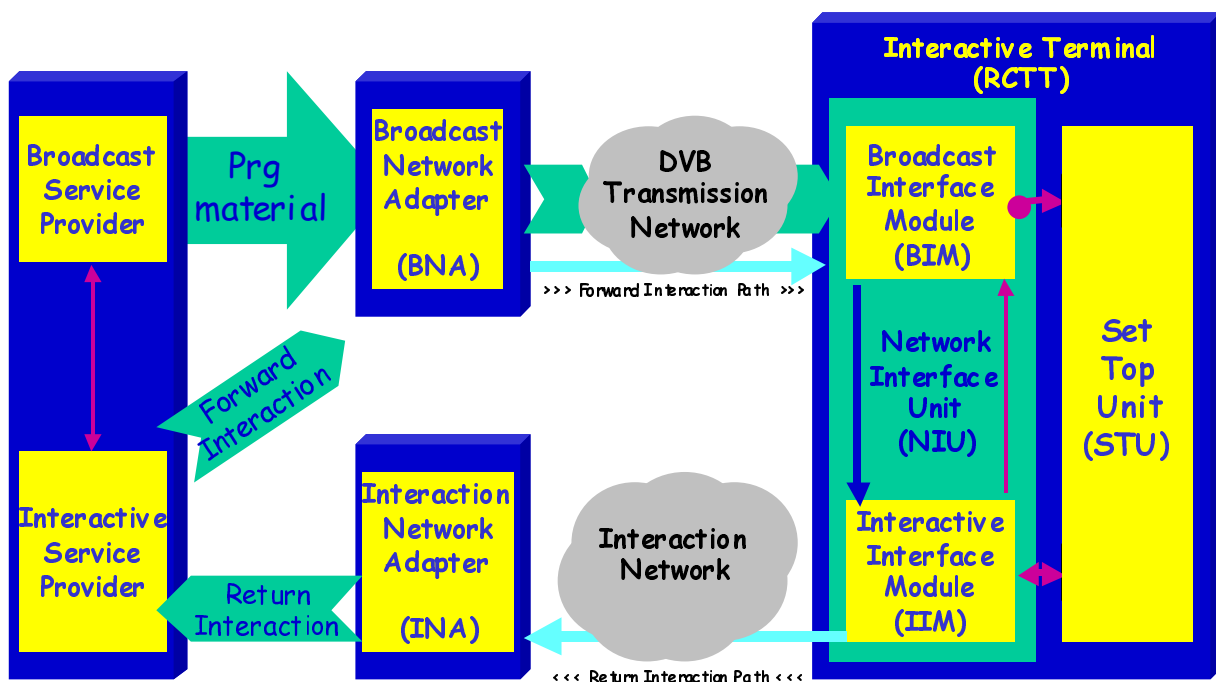

Figure 3: Reference Model for Terrestrial Interactive Systems

The downstream, carrying both the broadcast content and the Forward Interaction Path data, shall be based on the DVB-T standard (EN 300 744 [1]). The upstream, carrying the Return Interaction Path data, shall be based on the present document (DVB-RCT).

The Interactive Terminal also named Return Channel Terrestrial Terminal (RCTT) provides interface for both a broadcast and an interaction channel. The RCTT is formed by the Network Interface Unit (NIU) and the Set Top Unit (STU). The Network Interface Unit (NIU) consists of the Broadcast Interface Module (BIM) and the Interactive Interface Module (IIM).

5 DVB-RCT Interaction Channel for Terrestrial Networks

The DVB-RCT system is able to provide interactive service for Terrestrial Digital TV, using the existing infrastructure already used to broadcast DVB-T services.

The Terrestrial Return Channel system (DVB-RCT) is based on In-Band (IB) downstream signalling. Accordingly, the Forward Information path data are embedded into the MPEG-2 TS packet, themselves carried in the DVB-T broadcast channel.

The Forward Information path is made up of MPEG-2 TS packets having a specific PID and carrying the Medium Access Control management data.

The Return Interaction path is mainly made up of ATM cells mapped onto physical bursts. ATM cells include Application data messages and Medium Access Control management data. The MAC messages control the access of the RCTTs to the shared medium.

5.1 System Concept

The interactive system consists of a forward interaction channel (downstream) which is based upon an MPEG-2 Transport Stream conveyed to the user via a DVB-T [1] compliant terrestrial broadcast network, and a return interaction channel based on a VHF/UHF transmission (upstream). A typical DVB-RCT system is illustrated in figure 4.

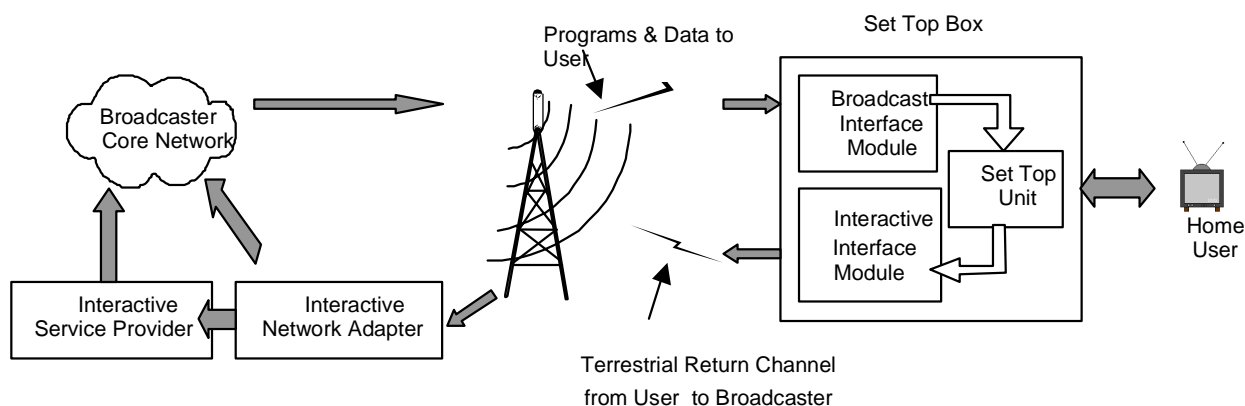

Figure 4: Illustration of the DVB-RCT network

The downstream transmission from the Base Station (INA) to the RCTTs (NIUs) provides synchronization and information to all RCTTs. That allows RCTTs to synchronously access the network and then to transmit upstream synchronized information to the Base Station. RCTTs can use the same antenna used for reception of the broadcast channel signal. The return channel signal may either be transmitted directly to a Base Station co-located with the broadcast transmitter site, or to a Base Station included in a cellular network of Base Stations.

To allow access by multiple users, the VHF/UHF radio frequency return channel is partitioned both in the frequency and time domains, using frequency division (FD) and time division (TD).

A global synchronization signal, required for the correct operation of the upstream demodulator at the Base Station, is transmitted to all users via global DVB-T timing signals. Time synchronization signals are conveyed to all users through the broadcast channel, either within the MPEG2 Transport Stream or via global DVB-T timing signals. More precisely, the DVB-RCT frequency synchronization is derived from the broadcast DVB-T signal whilst the time synchronization results from the use of MAC management packets conveyed through the broadcast channel.

The DVB-RCT system follows the following rules:

- each authorized RCTT transmits one or several low bit rate modulated carriers towards the Base Station (INA);
- the carriers are frequency-locked and power ranged and the timing of the modulation is synchronized by the Base Station (INA);
- on the INA side, the Upstream signal is demodulated, using a FFT process, just like the one performed in a DVB-T receiver.

5.2 Lower Physical Layer principle

The following figures show the conceptual block diagrams resulting from the implementation of the present document, in the RCTT and in the Base Station.

As shown in figure 5, the receiving part of the RCTT is strictly compliant with the DVB-T system specification (EN 300 744 [1]). In addition to the set-top-box unit, the DVB-T demodulated MPEG-TS feeds the MAC and Synchronization blocks.

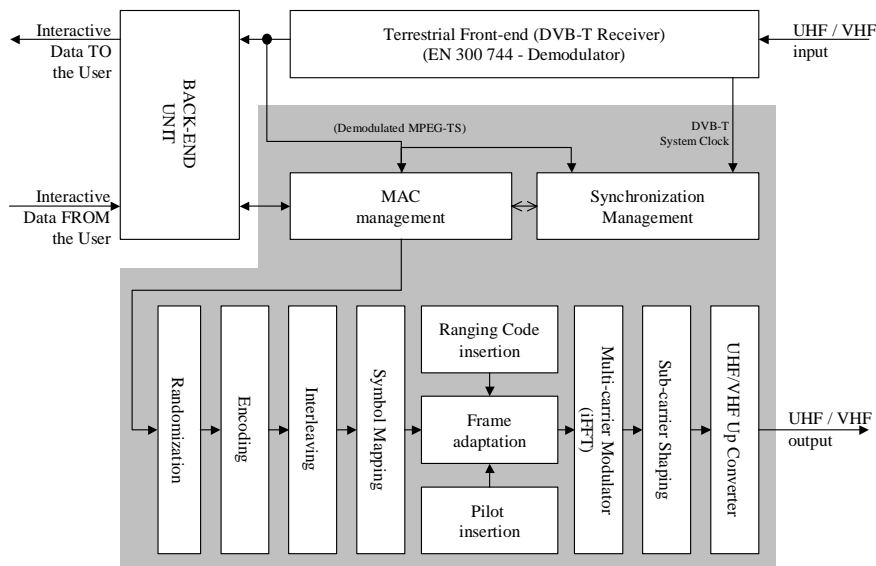

Figure 5: Conceptual Block Diagram for the DVB-RCT

The synchronization of the DVB-RCT module (NIU) is achieved using the MAC control messages (to perform time synchronization) and using frequency information issued from the DVB-T demodulator (the recovered DVB-T system clock).

MAC control messages, extracted from the incoming MPEG-TS, are processed by the MAC management block to instruct the DVB-RCT modulator on the transmission resources assigned to it and to tune the access performed to the radio frequency return channel.

The User Interactive data, are then embedded in the Return Interaction Path by the NIU modulator, as defined in the present document.

At the Base Station, as shown in figure 6, the UHF/VHF signals, issued by the RCTTs, are demodulated (by the use of an FFT) and sent to the MAC layer management block.

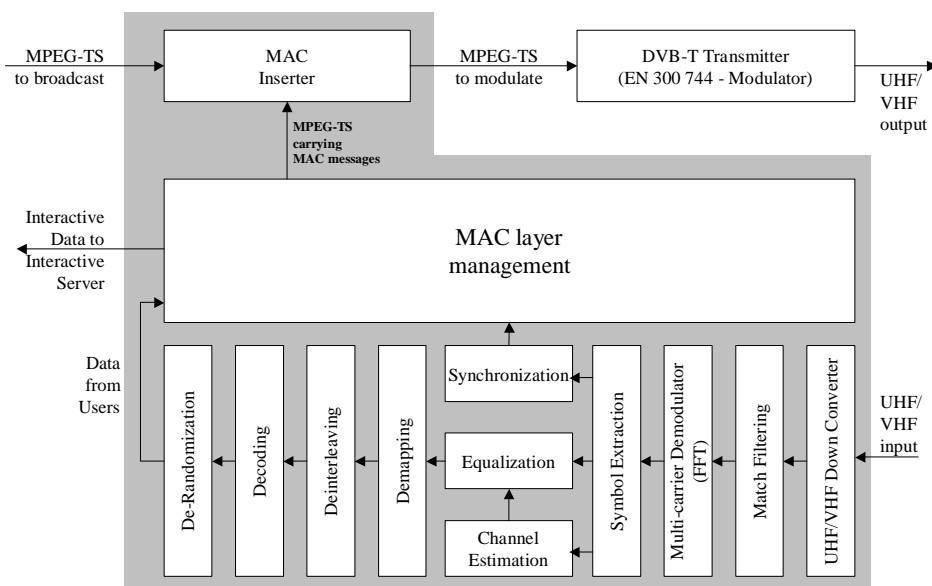

Figure 6: Conceptual Block Diagram for the Base Station

The MAC layer management processes the messages received from the users:

- the application messages are routed back to the Interactive Service Servers (through any communication network);
- the MAC management messages are processed and result in the generation of the Forward Interaction messages which are embedded in the main MPEG-TS broadcast channel by the MAC inserter.

5.3 Forward Interaction Path (Downstream IB)

As already stated, the In Band Forward Interaction Path shall use a MPEG-2 TS stream broadcast in compliance with the DVB-T standard [1].

Frequency range, channel spacing, and other lower physical layer parameters shall follow the DVB-T standard (EN 300 744 [1]).

5.4 Return Interaction Path (Upstream)

For correct operation of the demodulator at the base station, the carriers modulated by each RCTT shall be synchronized both in the frequency and time domains.

The frequency tolerance for any carrier produced by a RCTT, in regard to its nominal value, depends on the transmission mode used (i.e. the inter-carrier spacing). The frequency and timing accuracy are given in clause 6.14.4.

6 DVB-RCT Upstream Physical layer specifications

6.1 General principles

To provide a shared wireless return channel for DVB Terrestrial distribution system, the DVB-RCT standard makes use of a dedicated radio frequency channel and organizes it to allow concurrent access from many individual RCTTs.

The method used to organize the DVB-RCT channel is inspired by the DVB-T standard: a partition of the whole radio frequency return channel is performed in both time and frequency domains. Accordingly, the DVB-RCT RF channel provides a grid of time-frequency slots, each slot usable by any RCTT.

The organization of the DVB-RCT Radio Frequency channel, at the lowest level of the physical layer, is illustrated in figure 7.

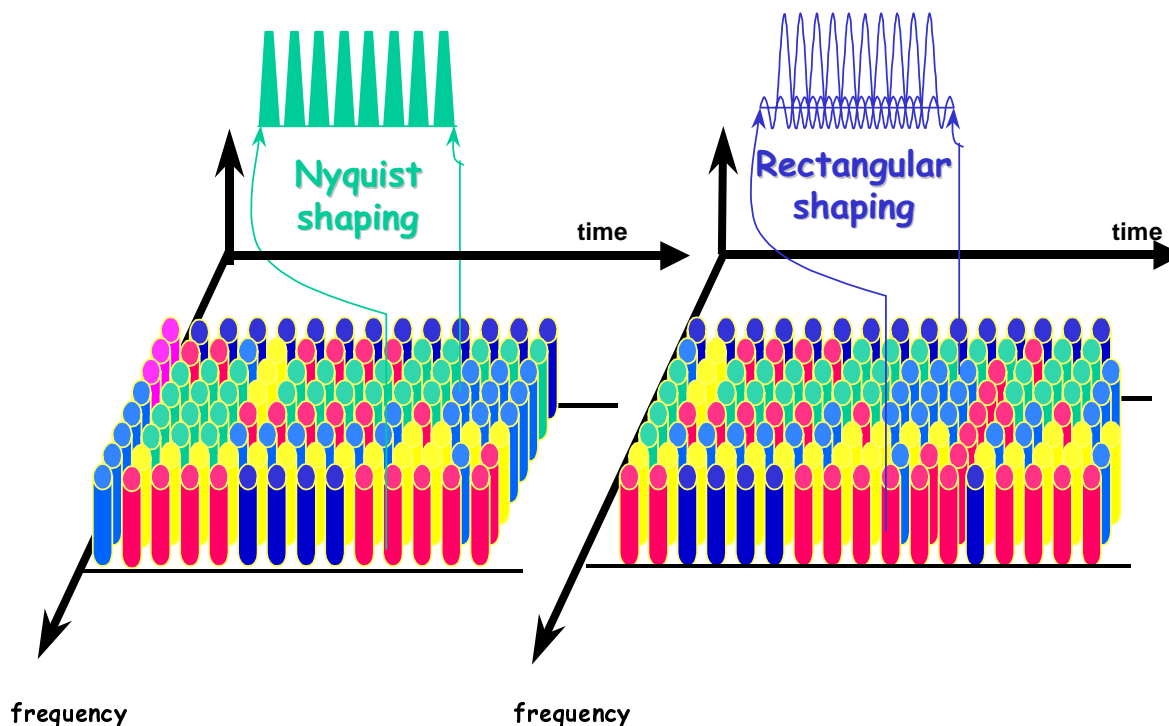

Figure 7: Illustration of the DVB-RCT Radio Frequency channel organization

The DVB-RCT standard provides for two types of sub-carrier shaping:

- **Nyquist shaping:** uses in-time Nyquist filtering on each carrier, to provide immunity against both inter-carrier and inter-symbol interference, as well as immunity against jammers;
- **Rectangular shaping:** makes use of an orthogonal arrangement of the carriers and of a Guard Interval between modulated symbols, to provide immunity against inter-carrier and inter-symbol interference, as well as combating multipath propagation effects.

The use of such shaping is strictly exclusive. Nyquist shaping and Rectangular shaping shall not be mixed in a given radio frequency return channel.

Depending upon the transmission mode used (as defined in clause 6.2), the total on-air signal ensemble is made up of a set of 1K or 2K adjacent carriers synchronously modulated by the active RCTTs. The MAC process inside the INA, manages the allocation of carriers among RCTTs (as defined in clauses 6.9 and 6.10).

The RCT standard defines two types of transmission frames, as presented in clause 6.3.2, which provide the necessary features to allow demodulation at the Base Station:

- the first transmission frame type is made up of a set of OFDM symbols, which contain several Data Sub-Channels, a Null symbol and a series of Synchronization/Ranging symbols;
- the second transmission frame type is made up of a set of general-purpose OFDM symbols, which contain either Data or Synchronization/Ranging Sub-Channels.

The RCTT transmits bursts of data based on an integer number of ATM cells (ATM cell is the usual container used to carry either MAC control or MAC data messages). Whatever the protection coding rate and the physical modulation, the data bursts have a constant number of 144 modulated symbols.

DVB-RCT defines three Burst Structures BS1, BS2 and BS3 (see clause 6.10), having their own characteristics in regard to the partitioning of the data bursts and the pilot carriers among the time-frequency slots.

The mapping of the Burst Structure onto the Transmission Frames is done under the control of the MAC process running in the Base Station. The present document defines three methods to map the Burst Structures onto the Transmission frames. Such mapping methods are named Medium Access Scheme (MAS) and are defined in clause 6.11.

The first type of transmission frame is suitable for Medium Access Scheme 1 and 2 (MAS1 and MAS2), which themselves describe respectively the mapping method for the Burst Structure 1 (BS1) and the Burst Structure 2 (BS2).

The second type of transmission frame is used only in case of Medium Access Scheme 3 (MAS3), and provides a mapping method to be use for the Burst Structure 2 (BS2) and the Burst Structure 3 (BS3).

6.2 Transmission modes

The DVB-RCT standard provides six transmission modes characterized by a dedicated combination of the maximum number of carriers used and their inter-carrier distance. Only one transmission mode shall be implemented in a given RCT Radio Frequency channel (i.e. transmission modes shall not be mixed).

The inter-carrier distance governs the robustness of the system in regard to the possible synchronization misalignment of any RCTT. Each value implies a given maximum transmission cell size, and a given resistance to the Doppler shift experienced when the RCTT is in motion.

The three-targeted DVB-RCT inter-carrier spacing values are defined in table 1.

Table 1: DVB-RCT approximate targeted inter-carrier spacing for 8 MHz channel

	Targeted ICS	
CS1	≈ 1 kHz	(resulting in a symbol duration of ≈ 1 000 μs)
CS2	≈ 2 kHz	(resulting in a symbol duration of ≈ 500 μs)
CS3	≈ 4 kHz	(resulting in a symbol duration of ≈ 250 μs)

The whole DVB-RCT Radio Frequency channel shall be populated with either 1 024 (1K) carriers or 2 048 (2K) carriers.

RCTTs shall derive their system clock from the DVB-T downstream. Accordingly, the transmission mode parameters, are fixed in a strict relationship with the DVB-T downstream, which themselves, according to EN 300 744 [1], are related to the DVB-T channel bandwidth used.

Table 2 gives the basic DVB-RCT transmission modes parameters applicable for the DVB-T transmission systems using 8 MHz, 7 MHz and 6 MHz radio frequency channels.

In table 2, the following definitions apply:

- **Total system carriers (Tsc):** is the total number of carriers managed by the DVB-RCT system;
- **Used Carrier (Cu):** is the maximum number of carriers effectively used by the RCTT. Extreme carriers are not used in order to provide guard bands for the protection of the adjacent channels;
- **RCT system clock (T):** is derived from the DVB-T downstream. In EN 300 744 [1] the DVB-T reference clock is defined as:
 - T for 8 MHz DVB-T system = 64/7 MHz or 7/64 μs;
 - T for 7 MHz DVB-T system = 8 MHz or 1/8 μs;
 - T for 6 MHz DVB-T system = 48/7 MHz or 7/48 μs.

Accordingly, the RCT system clock is defined as:

- four times the DVB-T system clock period in the case of CS1;
- two times the DVB-T system clock period in the case of CS2;
- one times the DVB-T system clock period in the case of CS3.

- **Useful Symbol Duration (T_u):** is the useful period of the symbol. It is expressed as $T_u = (T_{sc} \times T)$;
- **Carrier Spacing (C_s):** is the inter-carrier distance. It is expressed as $C_s = 1/T_u$;
- **RCT channel Bandwidth (B_u):** is the DVB-RCT channel used bandwidth. It is expressed as $B_u = C_s \times C_u$.

Table 2: DVB-RCT transmission mode parameters for the 8, 7 and 6 MHz DVB-T systems

	8 MHz DVB-T System		7 MHz DVB-T System		6 MHz DVB-T System	
	2 048	1 024	2 048	1 024	2 048	1 024
Total System Carriers	2 048	1 024	2 048	1 024	2 048	1 024
Used Carriers	1 712	842	1 712	842	1 712	842
RCT system clock	0,438 μ s	0,875 μ s	0,500 μ s	1,000 μ s	0,583 μ s	1,167 μ s
Useful Symbol Duration	896 μ s	896 μ s	1 024 μ s	1 024 μ s	1 195 μ s	1 195 μ s
Carriers Spacing	1 116 Hz	1 116 Hz	977 Hz	977 Hz	837 Hz	837 Hz
RCT channel bandwidth	1,911 MHz	0,940 MHz	1,672 MHz	0,822 MHz	1,433 MHz	0,705 MHz
RCT system clock	0,219 μ s	0,438 μ s	0,250 μ s	0,500 μ s	0,292 μ s	0,583 μ s
Useful Symbol Duration	448 μ s	448 μ s	512 μ s	512 μ s	597 μ s	597 μ s
Carriers Spacing	2 232 Hz	2 232 Hz	1 953 Hz	1 953 Hz	1 674 Hz	1 674 Hz
RCT channel bandwidth	3,821 MHz	1,879 MHz	3,344 MHz	1,645 MHz	2,866 MHz	1,410 MHz
RCT system clock	0,109 μ s	0,219 μ s	0,125 μ s	0,250 μ s	0,146 μ s	0,292 μ s
Useful Symbol Duration	224 μ s	224 μ s	256 μ s	256 μ s	299 μ s	299 μ s
Carriers Spacing	4 464 Hz	4 464 Hz	3 906 Hz	3 906 Hz	3 348 Hz	3 348 Hz
RCT channel bandwidth	7,643 MHz	3,759 MHz	6,688 MHz	3,289 MHz	5,732 MHz	2,819 MHz

Due to these definitions, the DVB-RCT final bandwidth is a function of the Carrier Spacing and of the FFT size. Each combination has a specific trade-off between frequency diversity and time diversity, and then between coverage range and portability capability.

It shall be noted that the total symbol duration depends on the shaping function applied to the carriers:

- when Nyquist shaping is used, even if the useful symbol duration has no physical signification, the total symbol duration is 1,25 times the inverse of the carrier spacing;
- when Rectangular shaping is applied, the useful symbol duration shall be increased by the guard interval duration, which should value 1/4 or 1/8 or 1/16 or 1/32 of the useful symbol duration.

6.3 Transmission frames

The DVB-RCT standard offers two types of transmission frames named TF1 and TF2.

Transmission frames provide the DVB-RCT radio frequency channel with a repetitive structure, made up of a set of time-frequency slots, in which Null Symbol, Ranging Symbols, Data Symbols and Pilot symbols are embedded to provide resources for synchronization and data transmission.

The MAC process running in the Base Station manages the resources provided by these transmission frames.

The following clauses define the general organization of these two types of transmission frames.

6.3.1 Transmission frames organization in the Frequency domain

Depending on the transmission mode in operation, one OFDM symbol is made of 2 048 carriers (2K mode) or 1 024 carriers (1K mode).

Table 3: Carrier organization for 1K and 2K modes

	2K mode structure	1K mode structure
Number of FFT points	2 048 (2K)	1 024 (1K)
Overall Usable Carriers	1 712	842
Used Carriers (see note)		
- With BS1 and BS2	1 708	840
- With BS3	1 711	841
Lower Channel Guard Band	168	91
Upper Channel Guard Band	168	91

NOTE: DC carrier is excluded for RF simplicity.

As shown in table 3, among these available carriers, the 2K mode offers 1 712 carriers (numbered 0 to 1 711) and the 1K mode offers 842 carriers (numbered 0 to 841) for carrying information. The unused carriers, located on each edge of the channel, provide a guard band to protect adjacent channels.

This organization is depicted in figure 8.

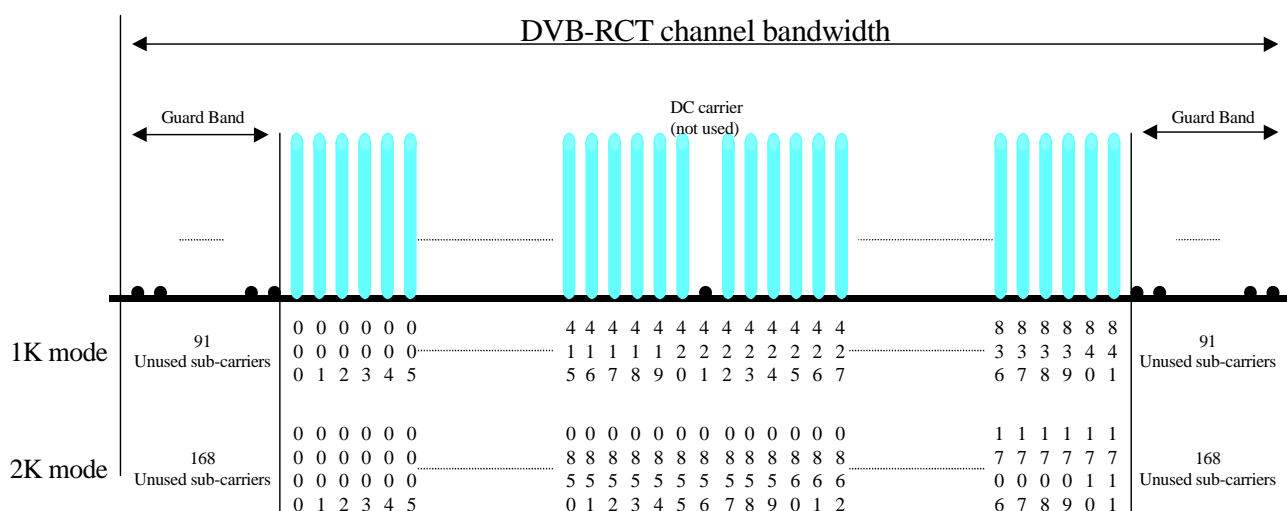

Figure 8: DVB-RCT channel organization for the 1K and 2K modes

6.3.2 Transmission frame organization in the Time domain

Two types of transmission frames are defined to provide the relevant features allowing the synchronization of the demodulator in the Base Station and to offer Ranging areas for the RCTTs.

6.3.2.1 Transmission frame 1 (TF1)

The first type of transmission frame (TF1) shall carry the three following category of symbols:

- Null Symbol: No transmission shall occur in the first OFDM symbol of the transmission frame. This Null Symbol allows to provide jammer detection by the receiving Base Station;
- Ranging symbols: Several consecutive OFDM symbols (6, 12, 24 or 48) are provided to allow Ranging feature to the RCTT (see clause 6.12);
- User Symbols: such part of the transmission frame allows the transmission of the Bursts Structures which themselves include the User Data and the Pilot carriers.

Figure 9 depicts the organization of TF1 frame in the time domain. It shall be noted that in figure 9, the Burst Structures are symbolized regarding their duration and not regarding their occupancy in the frequency domain. BS1 and BS2 make use of a set of carriers, named Sub-Channel, spread on the whole RCT channel.

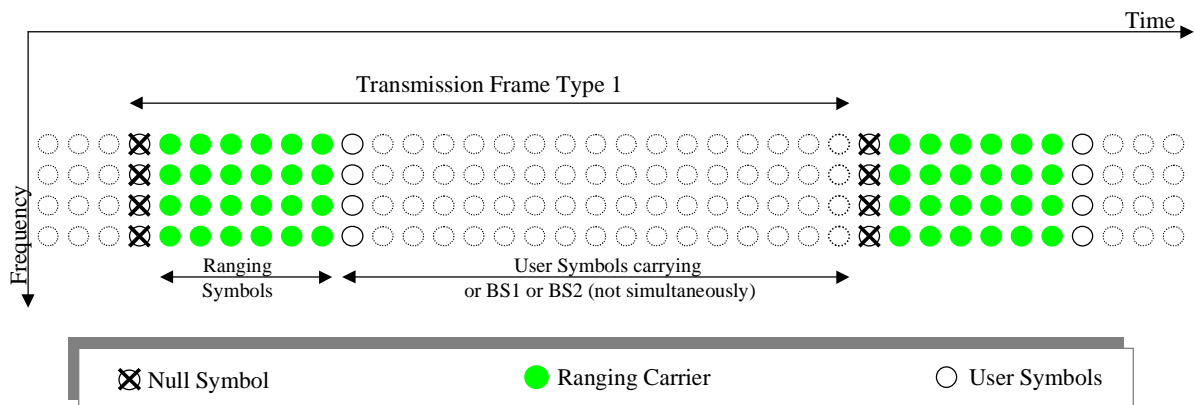

Figure 9: Organization of the TF1 frame (time domain)

Null Symbol and Ranging Symbols shall always use the Rectangular shaping.

The User part of TF1 shall use either Rectangular shaping or Nyquist shaping.

If the User part use the Rectangular shaping, the Guard Interval value shall be identical for any OFDM symbols embedded in the whole TF1 frame.

If the User part use the Nyquist shaping, the Guard Interval value to apply onto the Null Symbol and Ranging Symbols shall be 1/4.

The User part of TF1 frame is suitable to carry one Burst Structure 1 (BS1) or four Burst Structure 2 (BS2). BS1 and BS2 shall not be mixed in a given DVB-RCT channel.

6.3.2.2 Transmission frame 2 (TF2)

The second type of transmission frame (TF2) shall carry the two following categories of symbols in the same OFDM symbol:

- Ranging symbols: 8 Ranging Intervals (made of 6 consecutive symbols) which allows Ranging functions (see clause 6.12);
- User Symbols: to carry the Bursts Structures which themselves include Data and Pilot carriers.

Figure 10 depicts the organization of TF2 frame in the time domain. It shall be noted that in figure 10, the Burst Structures are symbolized regarding their duration and not regarding their occupancy in the frequency domain. BS2 and BS3 make use of a set of carriers, named Sub-Channel, spread on the whole RCT channel.

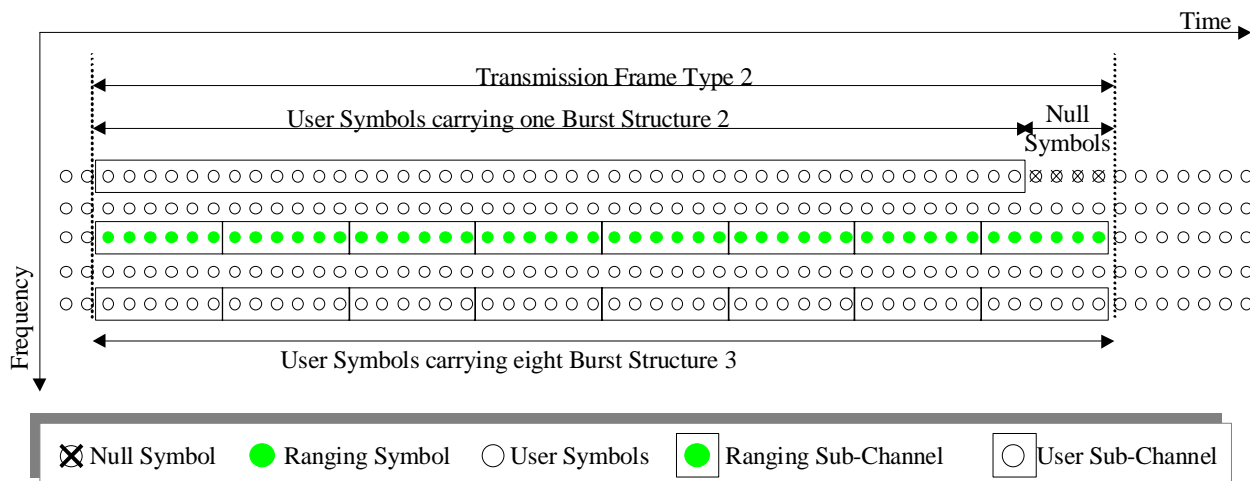

Figure 10: Organization of TF2 frame structure (time domain)

TF2 frame shall be used only in the Rectangular shaping case. The Guard Interval applied on any OFDM symbols embedded in the whole TF2 frame shall be the same (i.e. either 1/4, 1/8, 1/16 or 1/32 of the useful symbol duration).

The User part of the TF2 frame allows the usage of the Burst Structure 3 (BS3) or optionally, the Burst Structure 2 (BS2). When one BS2 is transmitted, it shall be completed by a set of four Null modulated Symbols to have a duration equals to the duration of eight BS3s. This method constitutes the Medium Access Scheme 3 (MAS3) as defined in clause 6.11.3.

6.4 RCTT synchronization

Synchronization to the RCTT upstream RF channel is an important feature of the Terrestrial interactive network. Constraints are imposed on the RCTTs to obtain an efficient MA-OFDM system with minimum interference between users.

To provide minimum interferences a two-step synchronization scheme is defined comprising a coarse (initial) synchronization based on downstream and a subsequent fine synchronization based on the Ranging procedure (see clause 8.4.3).

The initial synchronization process, which it is described hereafter, provides the RCTT with a minimum time and frequency accuracy before the RCTT uses ranging codes during the ranging procedure.

6.4.1 Coarse synchronization

The purpose of this synchronization process is to ensure that any given RCTT in the network transmits the Upstream transmission frames synchronously - this is achieved by aligning the Upstream transmission framing to that of the "slowest" RCTT in the network.

The Base Station provides the physical parameters (transmission frame type, duration) of the Upstream channels by means of Downstream MAC messages (see clause 8.4.2.2).

MPEG packets (PID 0x1C) with an Upstream Synchronization Field (Time Stamp, Slot Index) (see clause 7.2) periodically provide the start time and the Slot Index of the Upstream transmission frames.

One MPEG packet with an Upstream Synchronization Field shall be inserted in every period of:

- 62,5 ms (in the case 16 Hz insertion);
- 15,625 ms (in the case 64 Hz insertion);
- 3,906 25 ms (in the case 256 Hz insertion).

According to the insertion period and the time duration of the Upstream transmission frame, there will be some cases with several Upstream Synchronization Fields per transmission frame and other cases without:

- In the case that several Upstream Synchronization Fields are inserted by the Base Station within the time duration of a single Upstream transmission frame, these Upstream Synchronization Fields point to the same, upcoming Upstream transmission frame (see figure 12)
- In the case that no Upstream Synchronization Field is inserted by the Base Station within the time duration of a single Upstream transmission frame, the RCTT shall calculate the Slot Index and start time of the next and following Upstream transmission frames (see figure 12).

If there are several Upstream return channels providing different Upstream frame durations then the adequate Time Stamps shall be inserted in the Downstream channel and the RCTT shall obtain the relevant Upstream Synchronization Field according to the field "Time_Stamp_Identifier" (see clause 8.4.2.2).

In order to be able to perform a RCTT timing analysis, three different delays are defined (see figure 11).

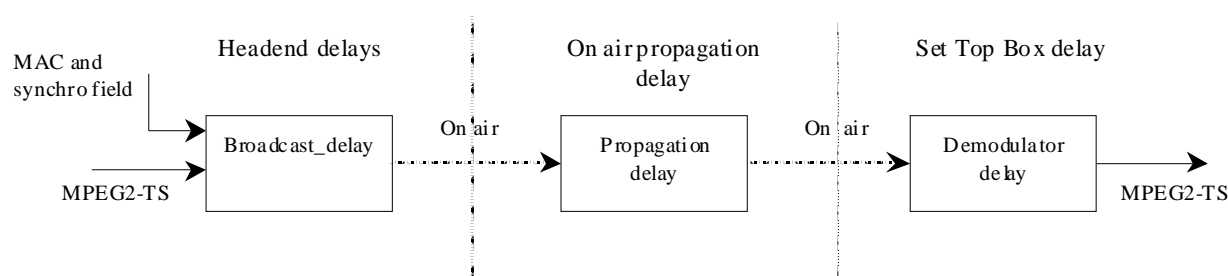

Figure 11: System Model for Timing Analysis

- The *Broadcast_delay* is the Base Station processing delay defined by the time when the Upstream Synchronization Field is inserted in a MPEG packet to the time it is on air. This delay shall remain constant for every byte;
- The *Propagation_delay* is a variable delay caused by any propagation paths between the Base Station and any given RCTT in the network;
- The *DVBT_demod_latency* is the delay between the input of the DVB-T demodulator and the MPEG output of a RCTT in the network. This delay is implementation dependent (it depends on the manufacturer), and can have either a constant or variable value for each byte in the data stream.

In short, the accumulated delay between the Base Station and any given RCTT in the network is the sum of a constant delay in the Base Station and two variable delays related to the channel and the RCTT processing.

The compensation of the *DVBT_demod_latency* shall be carried out as described in figure 12. Moreover each RCTT is responsible for compensating the internal RCT modulator design dependent delay.

DownStreamMPEG Transport Stream with Time Stamps inserted

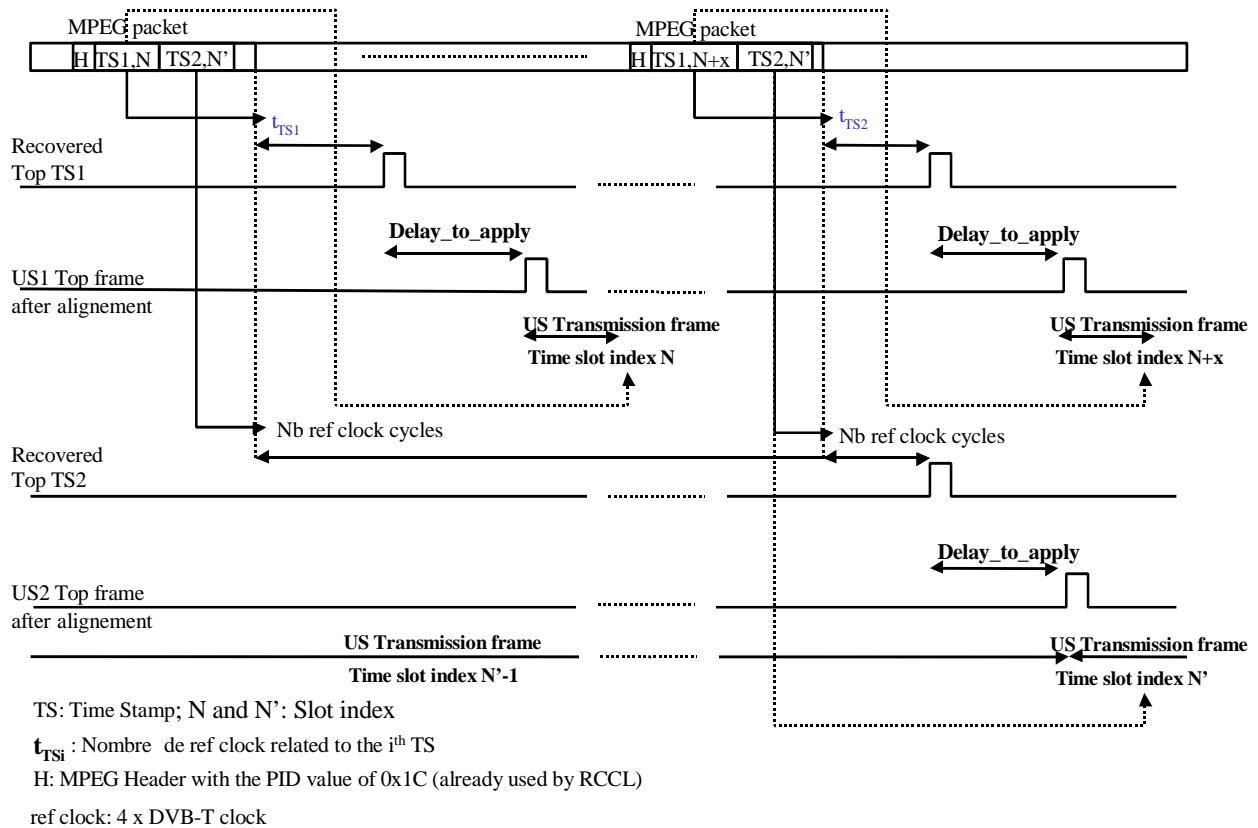

Figure 12: Time Stamp principle

Thus any given RCTT in the network shall determine the start of the Upstream transmission frames based on Time Stamps carried in the Upstream Synchronization Fields with an accuracy better than $\pm 4 \mu\text{s}$ (without taking into account the *Propagation_delay* and the *Broadcast_delay*).

The Time Stamp provides the number reference clock cycles ($4 \times \text{DVB-T clock}$) between the end of the MPEG packet containing the Time Stamp and the start frame signal. The value of the Time Stamp shall be between the minimum value of $T_{\text{MPEGpacket_duration}}$ and the maximum value of the Upstream transmission frame duration - $T_{\text{MPEGpacket_duration}}$. Where $T_{\text{MPEGpacket_duration}}$ is the duration of 1 MPEG packet measured in number of reference clock cycles.

Due to the difference in processing latency among the individual RCTTs in the network, each individual RCTT has to calculate, and make use of the following delay (see figure 12):

$$\text{Delay_to_apply} = \text{Delay_max} - \text{DVBT_demod_latency}.$$

The *Delay_max* is provided by the Base Station in a MAC message (clause 8.4.2.2). *Delay_max* is expressed as a number of DVB-T clock cycles and takes into account the longest delay needed to demodulate the forward COFDM signal in the slowest RCTT in the network. *Delay_max* is computed as the maximum delay after MAC packet insertion minus the *Broadcast_delay*. 24 bits are used for *Delay_max* in order to provide a maximum delay of 1,835 008 s with the 64/7 MHz clock.

In order to be synchronous with the Upstream framing, each RCTT in the network calculates the start of the Upstream transmission frame by adding the (internally calculated) *Delay_to_apply* to the value of the Time Stamp. This gives a global delay of *Delay_max* and takes into account the internal processing latency of each RCTT (see figure 12).

The Upstream transmission frame shall be numbered by the Slot Index provided in the Upstream Synchronization Field (see figure 12).

6.4.2 Symbol clock synchronization

In order to avoid time drift, the symbol clock of the RCTTs shall be locked to the DVB-T reference clock and on the Upstream transmission frame starts provided by the Time Stamp indications.

6.4.3 Carrier synchronization

The Time Stamps in the Upstream Synchronization Field provide the RCTT with a DVB-T clock reference from the Base Station. This reference clock in the Base Station shall have an accuracy of 0,001 ppm or better.

The RCTT can synchronize the carriers in phase and frequency to the RF Upstream channel by using phase locked techniques to synchronize the local oscillator controlling the RF upconverter in the RCTT to the reference clock from the Time Stamps.

This local carrier synchronization provides a way of adjusting the transmitted sub-carrier(s) of all RCTTs on the network. The required accuracy of this synchronization in the VHF/UHF bandwidth is defined as follows:

- Normalized sub-carrier(s) frequency accuracy shall be better than 10^{-7} in the case of 16 Upstream Synchronization Fields per second;
- Normalized sub-carrier(s) frequency accuracy shall be better than 4×10^{-8} in the case of 64 Upstream Synchronization Fields per second;
- Normalized sub-carrier(s) frequency accuracy shall be better than 10^{-8} in the case of 256 Upstream Synchronization Fields per second.

The required frequency accuracy is provided by the field `Synchro_field_rate` defined in the default configuration MAC message (see clause 8.4.2.2).

6.5 Signal definition

The messages from the RCTTs shall be first organized into Burst Structures (clause 6.10) or Ranging Sub-Channels (clause 6.12) and then mapped onto the relevant transmission frame (clause 6.11).

To construct the physical DVB-RCT signal, the RCTT shall process the messages to be transmitted by applying the following functions:

- Data Randomization (see clause 6.7.1);
- Encoding (see clause 6.7.2);
- Interleaving (see clause 6.7.3);
- Formatting (see clauses 6.10 and 6.11);
- Modulation (see clause 6.8);
- Shaping (see clause 6.9).

6.6 Transmitted signal

The signal transmitted by a RCTT is defined using the following formula:

$$S_u(t) = \text{Re} \left\{ \sum_{k \in K'} \sum_{n=N_0}^{N_E} a_{k,n} \times g(t - nT_s) \times \exp \left[i2\pi \left(f_0 + \frac{k}{t_s} \right) t \right] \right\}$$

where:

- k - denotes the transmitted carrier index;
- K' - denotes a set of carriers defined as Sub-Channel;
- n - denotes the symbol number within the transmitted frame (i.e. burst);
- N_0 - denotes the starting symbol number within the transmitted frame;
- N_E - denotes the ending symbol number within the transmitted frame;
- T_s - is the symbol duration;
- t_s - is the inverse of the carrier spacing;
- f_0 - is the frequency of first carrier (the one with the lowest frequency) in the pool of carriers;
- $a_{k,n}$ - is the complex modulation symbol for carrier k of the data symbol number n ;
- $g(t)$ - denotes the shaping filtering function;
- t - is considered here as the time, set to 0 at the very beginning of a Burst Structure.

6.7 Randomization, Channel encoding and Interleaving

As shown in figure 13, before modulation, the data to be transmitted shall be processed sequentially using:

- a variable randomization procedure (which depends on the length of the data payload to be transmitted);
- an error correction encoding using either a Turbo-Code encoder or a concatenated Reed Solomon and punctured convolutional encoder;
- a bit interleaver.

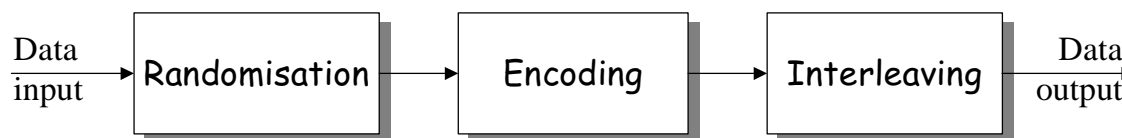

Figure 13: Conceptual diagram of the Return Channel (RC) Encoding and Interleaving

6.7.1 Data Randomization

Figure 14 illustrates the data randomizer, which shall be used by RCTT.

The shift-register of the randomizer shall be initialized for each new data payload with the binary value: 1001010000000 (45 200 in octal). Each data byte to be transmitted shall enter sequentially into the randomizer, MSB first.

The Pseudo Random Binary Sequence (PRBS) generator shall be $1 + X^{14} + X^{15}$.

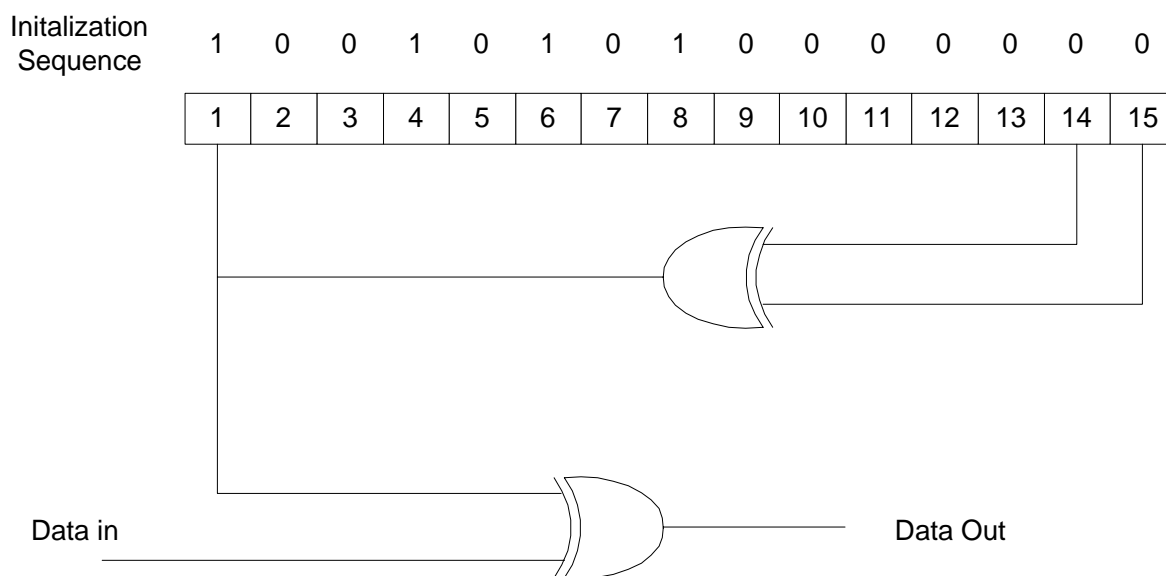

Figure 14: Block diagram for Data Randomization

The bit issued from the randomizer shall be applied to the encoder. The randomizer shall be reset for each data burst transmitted on any Sub-Channel.

6.7.2 Channel encoding

Two-channel encoding methods are defined in the present document:

- Turbo encoding;
- concatenated Reed-Solomon encoding and convolutional encoding.

Only one of these shall be implemented in a given DVB-RCT RF channel. Whatever the method used, the data bursts, produced after the encoding and physical modulation processes, shall have a fixed length of 144 modulated symbols.

Table 4 defines the original sizes of the useful data payloads to be encoded in relation with the selected physical modulation and encoding rate.

Table 4: Useful data payload of a burst

	QPSK		16 QAM		64 QAM	
Encoding rate	R = 1/2	R = 3/4	R = 1/2	R = 3/4	R = 1/2	R = 3/4
Data payload in 144 symbols	18 bytes	27 bytes	36 bytes	54 bytes	54 bytes	81 bytes

It shall be noted that, under control of the Base Station (INA), a given RCTT can produce successive bursts having different combinations of encoding rates. This capability, named adaptive modulation, aims to provide flexible bitrate capacity to each RCTT, in relation to the individual reception conditions encountered in the Base Station.

6.7.2.1 Channel encoding using Turbo codes

The encoding method described in this clause is an alternative of the concatenated encoders defined in clause 6.7.2.2.

The Turbo encoder block diagram is depicted in figure 15. It uses a double binary Circular Recursive Systematic Convolutional (CRSC) code.

The MSB bit of the first byte of the useful payload is assigned to A, the next bit to B and so on for the remaining of the data burst content.

The encoder is fed by blocks of k bits or N couples ($k = 2 \times N$ bits). N is a multiple of 4 (k is a multiple of 8).

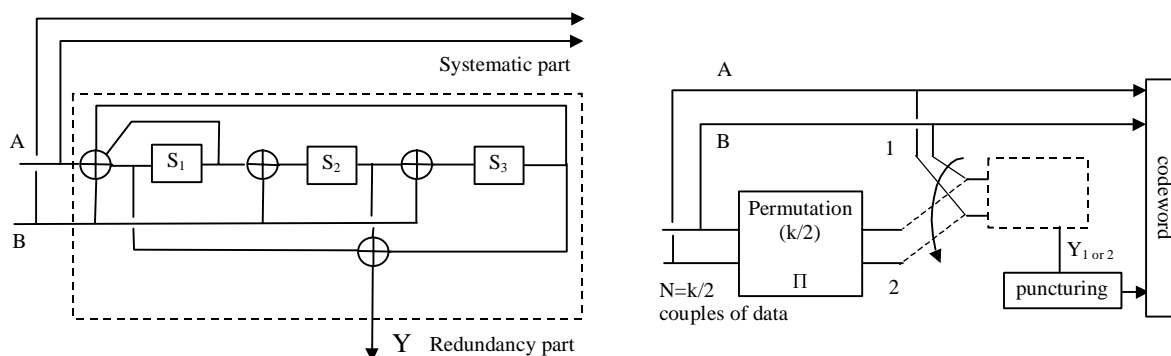

Figure 15: Encoder block diagram (turbo code)

The polynomials, which shall be used for the connections, are described in octal and symbolic notations as follows:

- for the feedback branch: 15 (in octal), equivalently $1 + D + D^3$ (in symbolic notation);
- for the Y parity bits: 13, equivalently $1 + D^2 + D^3$.

The input A bit shall be connected to tap "1" of the shift register and the input B bit shall be connected to the taps "1", D and D^2 .

After initialization by the circulation state S_{C_1} (see clause 6.7.2.1.2), the encoder shall be fed by the sequence in the natural order (switch on position 1) with incremental address $i = 0, \dots, N-1$. This first encoding is called C_1 encoding.

After initialization by the circulation state S_{C_2} (see clause 6.7.2.1.2), the encoder shall be fed by the interleaved sequence (switch in position 2) with incremental address $j = 0, \dots, N-1$. This second encoding is called C_2 encoding.

The function $\Pi(j)$ that gives the natural address i of the considered couple, when reading it at place j for the second encoding, is given in clause 6.7.2.1.1.

6.7.2.1.1 Turbo code permutation

The permutation shall be done on two levels:

- the first one inside the couples (level 1);
- the second one between couples (level 2).

The level 2 permutation is expressed in the following algorithm.

Set the permutation parameters P_0, P_1, P_2 and P_3

$$j = 0, \dots, N-1$$

level 1:

if $j \bmod 2 = 0$, let $(A,B) = (B,A)$ (invert the couple)

level 2:

if $j \bmod 4 = 0$, then $P = 0$;

if $j \bmod 4 = 1$, then $P = N/2 + P_1$;

if $j \bmod 4 = 2$, then $P = P_2$;

if $j \bmod 4 = 3$, then $P = N/2 + P_3$.

$$i = P_0 \times j + P + 1 \bmod N$$

Table 5 provides the combinations of the parameters N , P_0 , P_1 , P_2 and P_3 , which shall be applied when using this algorithm.

Table 5: Turbo code permutation parameters

Frame size in couples	P_0	$\{P_1, P_2, P_3\}$
$N = 72$ (18 bytes)	11	{6, 0, 6}
$N = 108$ (27 bytes)	11	{54, 56, 2}
$N = 144$ (36 bytes)	17	{74, 72, 2}
$N = 216$ (54 bytes)	31	{2, 4, 10}
$N = 324$ (81 bytes)	11	{172, 164, 16}

The interleaving relations shall satisfy the odd/even rule (i.e. when j is even, i is odd and vice-versa) then enables the puncturing patterns to be identical for the two encoding levels.

6.7.2.1.2 Determination of the circulation states

The state of the encoder is denoted S ($0 \leq S \leq 7$) with $S = 4 \times s_1 + 2 \times s_2 + s_3$ (see table 6). The circulation states S_{C1} and S_{C2} shall be determined by the following operations:

- 1) Initialize the encoder with state 0. Encode the sequence in the natural order for the determination of S_{C1} or in the interleaved order for the determination of S_{C2} (without producing redundancy). In both cases, the final state of the encoder is denoted S_{N-1}^0 ;
- 2) According to the length N of the sequence, the following correspondence shall be used to find S_{C1} or S_{C2} (see table 6).

Table 6: Circulation state correspondence table

$N \bmod 7$	S_{N-1}^0	0	1	2	3	4	5	6	7
1		$S_C = 0$	$S_C = 6$	$S_C = 4$	$S_C = 2$	$S_C = 7$	$S_C = 1$	$S_C = 3$	$S_C = 5$
2		$S_C = 0$	$S_C = 3$	$S_C = 7$	$S_C = 4$	$S_C = 5$	$S_C = 6$	$S_C = 2$	$S_C = 1$
3		$S_C = 0$	$S_C = 5$	$S_C = 3$	$S_C = 6$	$S_C = 2$	$S_C = 7$	$S_C = 1$	$S_C = 4$
4		$S_C = 0$	$S_C = 4$	$S_C = 1$	$S_C = 5$	$S_C = 6$	$S_C = 2$	$S_C = 7$	$S_C = 3$
5		$S_C = 0$	$S_C = 2$	$S_C = 5$	$S_C = 7$	$S_C = 1$	$S_C = 3$	$S_C = 4$	$S_C = 6$
6		$S_C = 0$	$S_C = 7$	$S_C = 6$	$S_C = 1$	$S_C = 3$	$S_C = 4$	$S_C = 5$	$S_C = 2$

6.7.2.1.3 Rates and puncturing map

Two code rates are defined: $R = 1/2, 3/4$. These rates shall be achieved through selectively deleting the parity bits (puncturing). The puncturing patterns defined in table 7 shall be applied.

Table 7: Puncturing patterns for Turbo codes ("1" = keep, "0" = delete)

Code Rate	Puncturing Vector
1/2	$Y = [1\ 1\ 1]$
3/4	$Y = [1\ 0\ 0]$

In table 7, value "1" means the bit shall be kept, while the value "0" means the bit shall be deleted.

The puncturing patterns shall be identical for both codes C_1 and C_2 . The puncturing rate shall be defined to the RCTT by the MAC process.

6.7.2.1.4 Order of output

The encoder shall produce sequentially:

- all original couples (A, B) in the same sequence that they have entered the encoder;
- then, all the encoded bits (Y1); and finally
- all the interleaved and encoded bits (Y2).

The output of the encoder shall feed the interleaver described in clause 6.7.3 with A first.

6.7.2.2 Channel encoding using concatenated codes

The encoding method described in this clause is an alternative of the Turbo encoders defined in clause 6.7.2.1.

The data shall first enter the RS encoder (defined in clause 6.7.2.2.1) and are then passed to the tail biting convolutional encoder (defined in clause 6.7.2.2.2).

6.7.2.2.1 Reed Solomon encoding

The Reed Solomon encoding process shall use the systematic RS(63, 55, t = 4).

The following polynomials shall be used:

- Code generator polynomial: $g(x) = (x + \lambda^0)(x + \lambda^1)(x + \lambda^2) \dots (x + \lambda^7), \lambda = 02_{hex}$;
- Field Generator polynomial: $p(x) = x^6 + x + 1$.

The coding produced, although based upon the systematic RS(63, 55, t = 4), could be varied by the number of parity symbols sent. The maximum parity symbols of the chosen RS code is 8. Less parity symbols can be used, by deleting some of the parity symbols from the end of the block at the transmission side (i.e. in the RCTT) and then using erasures at the receiver side (i.e. in the Base Station).

In DVB-RCT, a shortened code shall be produced by padding with zero the start of the stream to be encoded. The zero padding length depends on the code rate to be produced. Accordingly, the code rates as defined in table 8, shall be produced.

Table 8: Code rates for Reed Solomon encoding

RS Code Rate	Encoding scheme	Transmitted scheme
$\frac{3}{4}$	31 zero symbols, 24 Data symbols, No erasures - Using 8 parity symbols.	32 symbols
$\frac{9}{10}$	19 zero symbols, 36 Data symbols, 4 erasures - Using first 4 parity symbols of the 8 parity symbols.	40 symbols

6.7.2.2.2 Convolutional coding

Data bits issued from the Reed Solomon encoder, described in clause 6.7.2.2.1, shall feed the convolutional encoder depicted in figure 16.

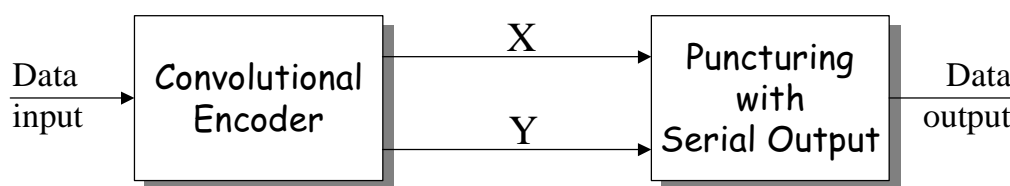

Figure 16: Convolutional encoder Block diagram

The Convolutional encoder shall have a constraint length equal to nine (9) and shall use the following mother codes:

$$G_1 = 561_{oct} \text{ For X}$$

$$G_1 = 753_{oct} \text{ For Y}$$

A basic convolutional encoding scheme, as depicted in figure 17, shall be used.

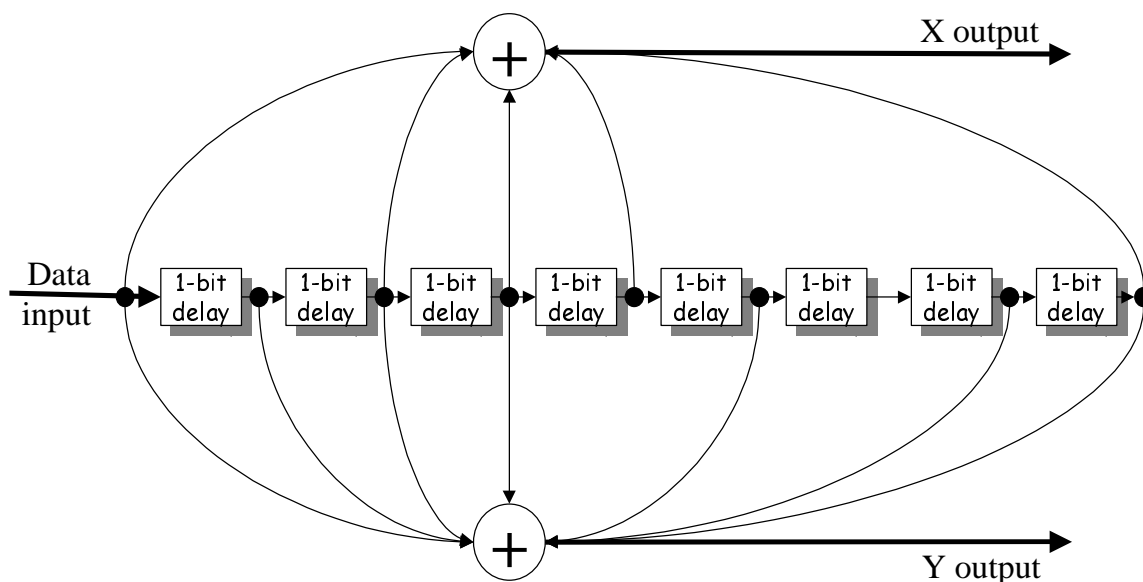

Figure 17: Convolutional Encoder Block diagram

The puncturing pattern shall be as defined in table 9.

Table 9: Puncturing pattern for DVB-RCT

CC Code Rate	Puncturing Pattern	Transmitted Sequence (after parallel to serial conversion)
$\frac{2}{3}$	X: 1 0 Y: 1 1	$X_1Y_1Y_2$
$\frac{5}{6}$	X: 1 0 1 0 1 Y: 1 1 0 1 0	$X_1Y_1Y_2X_3Y_4X_5$

In order to achieve a tail biting convolutional encoding the memory of the convolutional encoder shall be initialized with the last data bits of the RS packet (the packet data bits are numbered $b_1..b_n$).

6.7.2.2.3 Concatenated Coding

Concatenated coding results from the joint processes of the Reed Solomon (RS) encoder and the Convolutional punctured (CC) encoder.

To produce the two global coding rates expected ($1/2$ and $3/4$) the RS and CC encoder shall implement the coding rate defined in table 10.

Table 10: Global, RS and CC encoding rates

Global Code Rate	CC Encoding	RS Encoding
$\frac{1}{2}$	$\frac{2}{3}$	$\frac{3}{4}$
$\frac{3}{4}$	$\frac{5}{6}$	$\frac{9}{10}$

The encoding parameters defined in table 11 shall be used to produce the desired coding rate in relation with the modulation schemes.

Table 11: Coding parameters for combination of coding rate and modulation

QPSK			
Code rate	RS input	CC input	CC output
$1/2$	144 bits = 24 RS Symbols	32 RS Symbols = 192 bits	288 bits
$3/4$	216 bits = 36 RS Symbols	40 RS Symbols = 240 bits	288 bits
16 QAM			
Code rate	RS input	CC input	CC output
$1/2$	288 bits = 2 x 24 RS Symbols	2 x 32 RS Symbols = 384 bits	576 bits
$3/4$	432 bits = 2 x 36 RS Symbols	2 x 40 RS Symbols = 480 bits	576 bits
64 QAM			
Code rate	RS input	CC input	CC output
$1/2$	432 bits = 3 x 24 RS Symbols	3 x 32 RS Symbols = 576 bits	864 bits
$3/4$	648 bits = 3 x 36 RS Symbols	3 x 40 RS Symbols = 720 bits	864 bits

6.7.3 Interleaving

The interleaving process shall be performed on each data burst issued either from the Turbo Encoder or the Concatenated Encoders.

Each data bit, output by the relevant encoder, shall feed the interleaver, which scrambles the order of the input bits to produce the interleaved data burst before supplying the symbol mapper.

A Pseudo Random Binary Sequence (PRBS) generator using the polynomial $1 + X^3 + X^{10}$ shall be used to make a random Interleaver. It shall be compliant with the one depicted in figure 18.

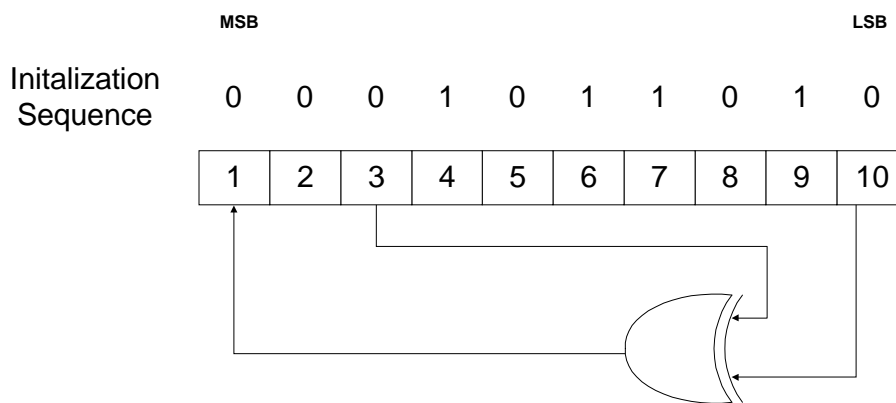

Figure 18: PRBS generator for random interleaving

At the beginning of each data burst, the PRBS generator shall be initialized with the binary value: 00 0101 1010 (05Ah).

The PRBS generator produces an index value, which shall correspond to the output position of the input bit into the output interleaved data burst (i.e. the new position is the value of the PRBS memory register and the first produced one equals to 00 0010 1101 (02Dh)).

The interleaver shall use the following algorithm:

- The Interleaver indexes range from 1 to n (where n denotes the block size to be interleaved);
- For each input bit, the PRBS shall be rotated;
- The rotation produces a number (which is the value of the PRBS memory register);
- If the obtained number is bigger than n, it shall be discarded and the PRBS shall be rotated again;
- The rotation shall continue until an index between 1 to n is produced;
- As soon as a valid index is obtained, it shall be used to address the position of the processed input bit into the output interleaved data burst.

This algorithm shall be repeated for each bit of the input data burst. The bit produced at the position 1 shall be output first.

6.8 Modulation Schemes

The physical modulation applied to the carriers by each RCTT shall be QPSK, 16QAM or 64QAM. The RCTT shall use the modulation scheme determined by the Base Station through MAC messages.

6.8.1 Constellations

Following the interleaving process defined in clause 6.7.3, the data bits shall enter sequentially into the symbol mapper, X_0 first. Mapping shall be performed by groups of bits, depending on the modulation chosen, to produce a complex number z , as illustrated in figure 19.

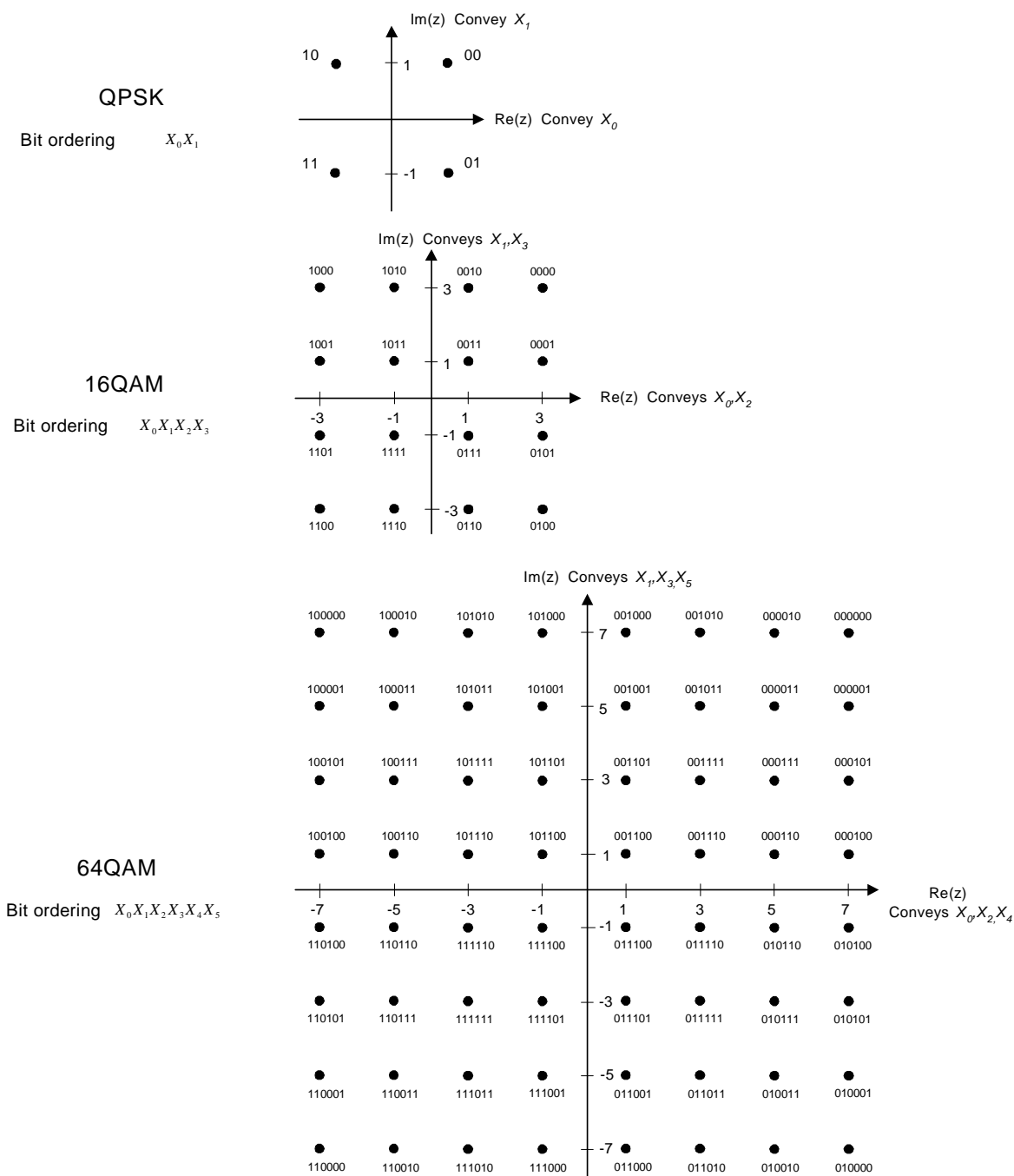

Figure 19: QPSK, 16QAM and 64QAM Constellations

In order to keep the energy of the constellation constant ($E[c \times c^*] = 1$), the complex number z shall be normalized to the value c , before mapping onto the carriers, by using the factor defined in table 12.

Table 12: Normalization factor for QPSK, 16QAM and 64QAM constellations

Modulation scheme	Normalization Factor
QPSK	$c = \frac{z}{\sqrt{2}}$
16QAM	$c = \frac{z}{\sqrt{10}}$
64QAM	$c = \frac{z}{\sqrt{42}}$

The complex number c , resulting from the normalization process, shall be modulated onto the allocated data carriers. The data mapping shall be done by sequentially modulating these complex values onto the relevant carriers.

6.8.2 Pilot modulation

Pilot carriers shall be inserted into each data burst in order to constitute the Burst Structure (see clause 6.10) and they shall be modulated according to their carrier location.

The Pseudo Random Binary Sequence (PRBS) generator depicted in figure 20, shall be used to produce a sequence, w_k . The polynomial for the PRBS generator shall be $X^{11} + X^2 + 1$.

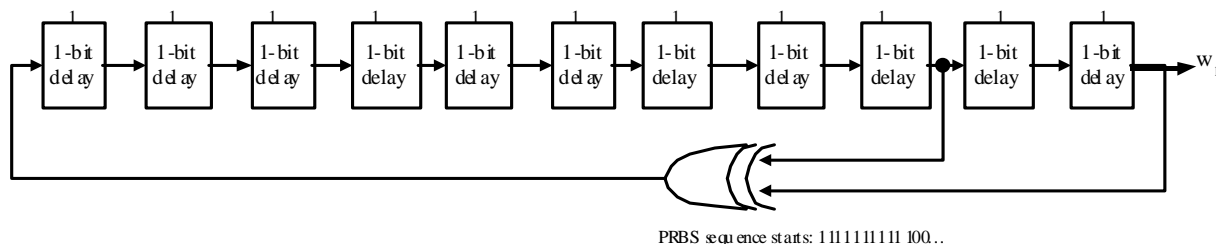

Figure 20: PRBS sequence generator for Pilot modulation

The value of the pilot modulation, on carrier k , shall be derived from w_k .

The PRBS shall be initialized so that its first output bit coincides with the first usable carrier. A new value shall be generated by the PRBS on every usable carrier. The DC carrier and the side-band carriers are not considered as usable carriers (see clause 6.3.1).

Two power levels shall be used for these pilots, corresponding to +2,5 dB or 0 dB relative to the mean useful symbol power. The selected power shall depend on the position of the pilot inside the Burst Structure as defined in clause 6.10.

The Boosted Pilot carriers shall be modulated according to the following formula:

$$\text{Re}\{C_k\} = 4 / 3 \times 2 (1/2 - w_k)$$

$$\text{Im}\{C_k\} = 0$$

The Non-Boosted Pilot carriers shall be modulated according to the following formula:

$$\text{Re}\{C_k\} = 2 (1/2 - w_k)$$

$$\text{Im}\{C_k\} = 0$$

6.8.3 Ranging Pilot modulation

Ranging shall be implemented in the Ranging Sub-Channels defined in clause 6.12.1.

Ranging shall be performed using the Ranging Codes defined in clause 6.12.2.

Ranging Pilots shall be generated using the following modulation:

$$\text{Re}\{C_{\text{rsc}, i}\} = 2 (1/2 - \text{RangingCodeBit}_{\text{rc}, i})$$

$$\text{Im}\{C_{\text{rsc}, i}\} = 0$$

Where

- $C_{\text{rsc}, i}$ denotes the i^{th} Carrier (i from 0 to 144) of Ranging Sub-Channel number rsc , as defined in clause 6.12.1;

- RangingCodeBit_{rc,i} is the value of the *i*th bit of the chosen Ranging Code_{rc}, according to the procedure defined in clause 6.12.2.

The Ranging Code Bits shall be produced by the PRBS generator, depicted in figure 21.

The PRBS polynomial generator shall be $1 + X + X^4 + X^7 + X^{15}$, it shall be initialized with the value 000 0000 1010 1001 (00A9h) to produce the first Ranging Code which will start with the bits 1100 1110 0...

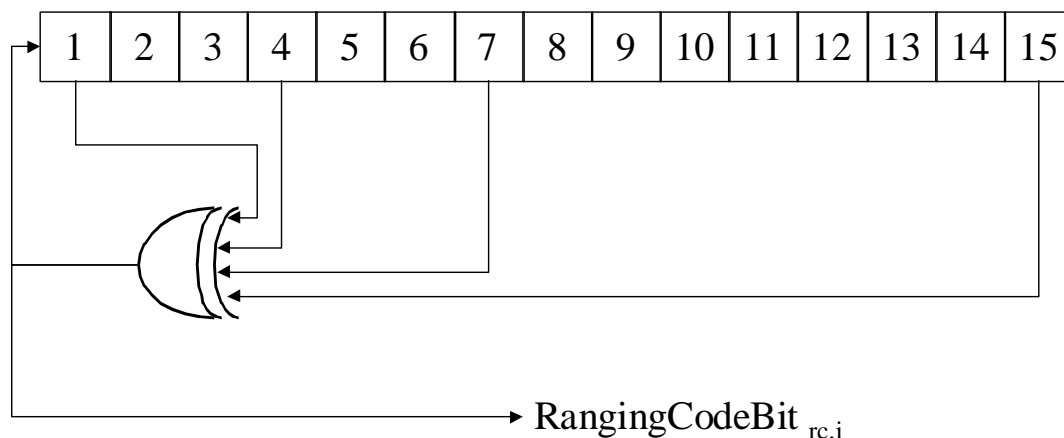

Figure 21: PRBS generator for Ranging Codes

6.9 Shaping filters

The signal shaping $g(t)$ shall be defined with reference to the signal transmitted on one carrier addressed by a user. Two shaping functions (Nyquist shaping and Rectangular shaping) are defined, the usage of which is exclusive in a given DVB-RCT channel.

6.9.1 The Nyquist shaping function

The Nyquist shaping function shall be implemented in order to produce a time-limited square root raised cosine pulse with a roll-off factor $\alpha = 0,25$.

The time-domain response of the square-root raised cosine pulse with excess bandwidth parameter $\alpha = 0,25$, and with a temporal extent limited to eight symbol periods, is given by:

$$g(t) = \frac{\sin\left[\frac{\pi t}{T_s}(1-\alpha)\right] + \frac{4\alpha t}{T_s} \cos\left[\frac{\pi t}{T_s}(1+\alpha)\right]}{\frac{\pi t}{T_s} \left[1 - \left(\frac{4\alpha t}{T_s}\right)^2\right]} \quad \text{for } t \in \{-4T_s..4T_s\}$$

$g(t) = 0$ elsewhere.

Where T_s is the symbol duration.

The 3 dB bandwidth occupancy of the signal is given by the following formula (NB: 6 dB in reception after the receiver's Nyquist filter):

$$BW_{3dB} = \frac{1}{T_s}$$

The relationship between T_s , t_s (inter-carrier spacing) and the α factor (roll off factor) provides the property of the individual separate spectra:

$$T_s = (1 + \alpha)t_s.$$

6.9.2 The Rectangular shaping function

The Rectangular shaping function shall be implemented in compliance with the following formula:

$$g(t) = \begin{cases} 1 & 0 \leq t \leq T_s \\ 0 & \textit{else} \end{cases}$$

where:

$g(t)$ denotes the shaping filtering function,

t is considered here as the time, set to 0 at the very beginning of a frame (burst),

T_s is the total symbol duration, including the guard interval Δ having the possible value $T_u/4$, $T_u/8$, $T_u/16$, $T_u/32$, where T_u is the useful symbol duration.

6.10 Burst Structure and formatting

The basic transmission slot allocated to a RCTT is called a burst.

The DVB-RCT standard provides three Burst Structures that give various combinations of time and frequency diversity, thereby providing various degrees of robustness, burst duration and a wide range of bit-rate capacity to the system.

Each burst structure makes use of a set of sub-carriers called a Sub-Channel.

One or several sub-channels can be used simultaneously by a given RCTT depending on the allocation performed by the MAC process.

The three different Burst Structures are defined as follows:

- Burst Structure 1 (BS1) shall use one unique sub-carrier to carry the total data burst over time, with an optional frequency hopping law applied within the duration of the burst;
- Burst Structure 2 (BS2) shall use simultaneously four sub-carriers, each carrying, over time, a quarter of the total data burst;
- Burst Structure 3 (BS3) shall use simultaneously twenty-nine sub-carriers, each carrying, over time, one over twenty-nine of the total data burst.

The three burst structures provide a pilot aided modulation scheme to allow coherent detection in the Base Station. The defined pilot insertion ratio is approximately 1/6, which means one pilot carrier is inserted for approximately every five data carriers.

6.10.1 Burst Structure 1 (BS1) definition

Burst Structure 1 (BS1) shall carry 144 data symbols transmitted over one carrier at a time. An optional frequency hopping law can be applied on the transmission within the burst duration.

BS1 is made up of four mini-bursts comprising data carriers and pilot carriers having a specific distribution pattern, as illustrated in figure 22.

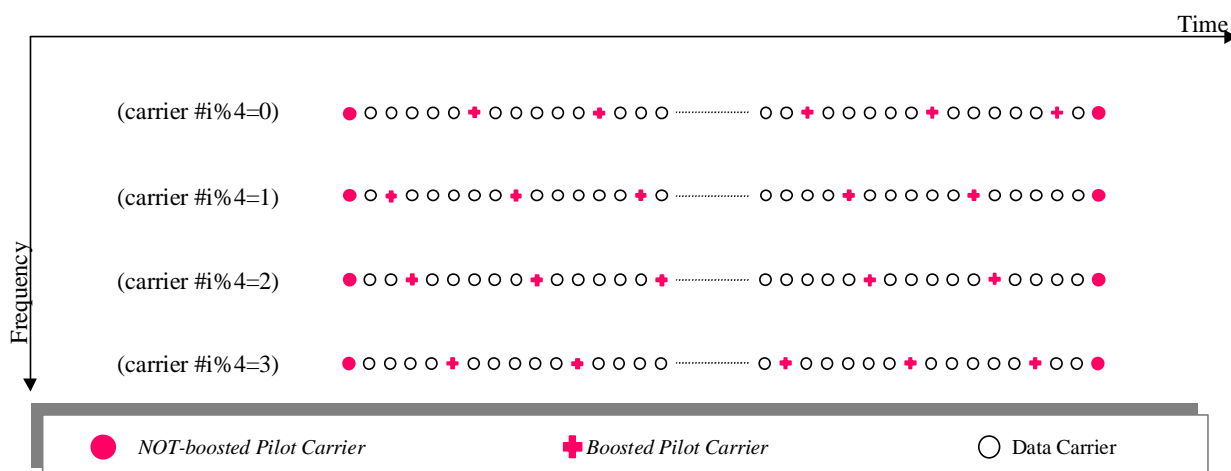

Figure 22: Pilot insertion scheme for the BS1 mini-bursts

To allow frequency hopping with Burst Structure 1, it shall be divided in four mini-bursts, forming a Sub-Channel.

The pilot distribution pattern used for the transmission of a mini-burst shall depend on the location ($i \text{ Modulo } 4$) of the carrier (i) over the multiplex of useful carriers.

The allocation of a carrier to the first mini-burst of the Sub-channel shall be compliant with the value given in table 13.

Table 13: BS1 Sub-Channel allocation parameters for Rectangular and Nyquist shaping

	2K mode	1K mode
Virtual Number of carriers in one OFDM symbol	2 048	1 024
Overall Carriers	1 712	842
Guard Band on each side	168	91
Maximum number of usable carriers	1 708	840
Excluded carrier number	0, 1, 856, 1 711	0, 421
Sub-Channel Numbering: SCN	2..855 and 857..1 710	1..420 and 422..841

Note that the DC carrier is excluded for RF simplicity.

6.10.1.1 Burst Structure 1 without frequency hopping

Data mapping shall be done sequentially, after encoding, interleaving and conversion of the binary stream to constellation signals, onto the consecutive 4 mini-bursts of a BS1 burst.

Each of the four mini-bursts, forming the BS1, shall be mapped onto the same carrier, in a time sequence.

Allocation of a carrier to a Sub-Channel, without frequency hopping option, shall follow the values given in table 14.

Table 14: BS1 allocation parameters without frequency hopping option

	Rectangular	Nyquist
Data Symbols in one mini-burst	36	36
Pilot Symbols in one mini-burst	9	9
Data Symbols in a burst	144	144
Pilot Symbols in a burst	36	36
Null pre- or post preamble symbols	0	8
Total number of Symbols in one Sub-channel allocation	180	188

Figure 23 illustrates the organization of BS1, carried over a carrier of index 0 modulo 4, using Rectangular window shaping. The same principle shall be applied for the other indexes of carrier location modulo 4.

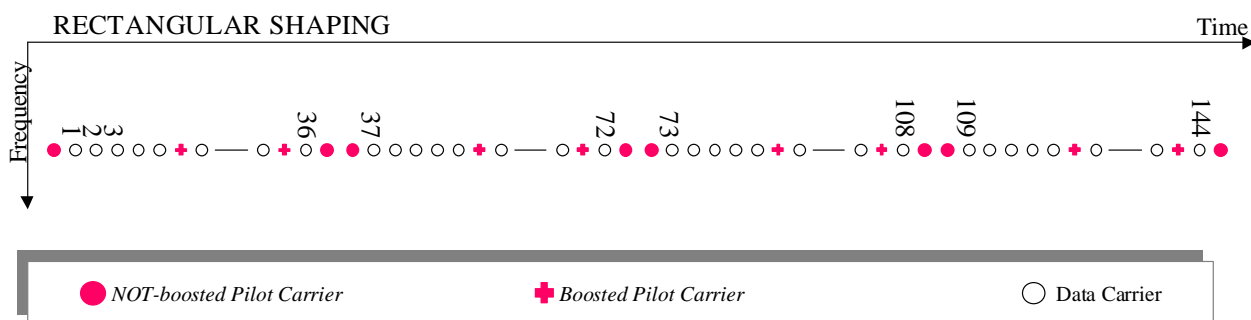

Figure 23: BS1 with rectangular shaping and without frequency hopping option

Figure 24 illustrates the organization of BS1, carried over a carrier of index 0 modulo 4, using Nyquist shaping. The same principle shall be applied for the other indexes of carrier location modulo 4.

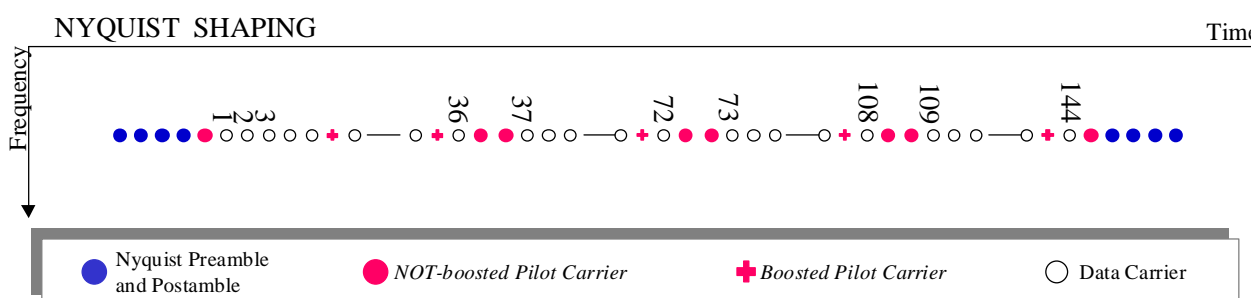

Figure 24: BS1 with Nyquist shaping and without frequency hopping option

6.10.1.2 Burst Structure 1 with frequency hopping

To provide frequency diversity to BS1, frequency hopping shall be optionally implemented between the transmission of the mini-bursts forming Burst Structure 1 (BS1).

Data mapping shall be done sequentially, after encoding, interleaving and conversion of the binary stream to constellation signals, onto the consecutive 4 mini-bursts of a BS1 burst.

Each mini-burst shall be mapped onto 4 different carriers. Allocation of a carrier to a Sub-Channel, with frequency hopping option, shall follow the values given in table 15.

Table 15: BS1 allocation parameters with frequency hopping option

	Rectangular	Nyquist
Data Symbols in one mini-burst	36	36
Pilot Symbols in one mini-burst	9	9
Data Symbols in a burst	144	144
Pilot Symbols in a burst	36	36
Null pre- or post preamble symbols	0	32
Total number of Symbols in one Sub-channel allocation	180	212

The pilot insertion scheme to apply on the four consecutive mini-bursts shall be derived from the corresponding carrier modulo 4 index, as depicted in figure 25 and figure 26.

Figure 25 shows BS1, with frequency hopping applied on Sub-Channel 4, thus transmitted over 4 carriers (4, 859, 431, 1 286) of modulo 4 index (0, 3, 3, 2) respectively, in the case of a RCT system using Rectangular shaping.

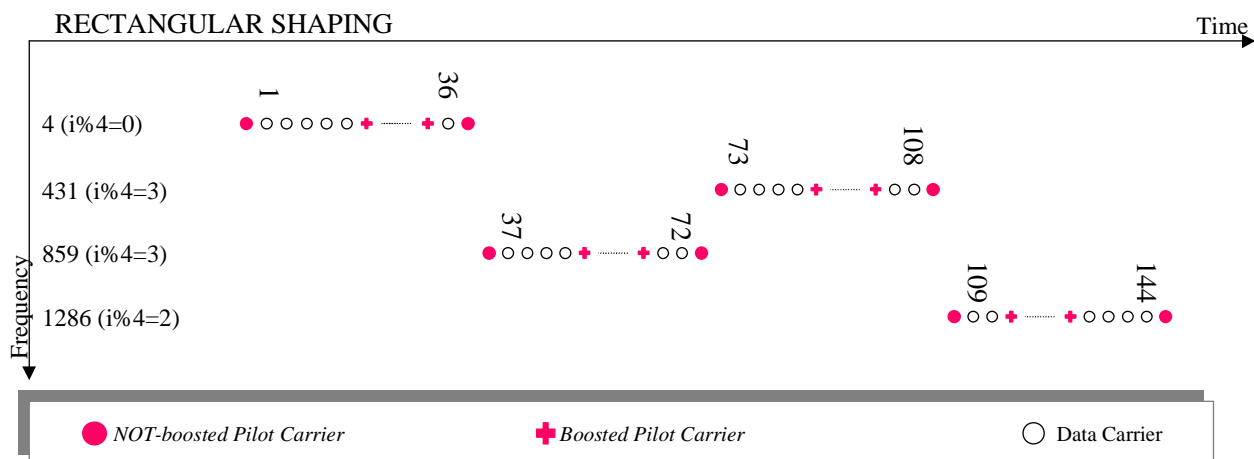

Figure 25: BS1 with frequency hopping and rectangular shaping

Figure 26 shows BS1, with frequency hopping applied on Sub-Channel 2, thus transmitted over 4 carriers (4, 859, 431, 1 286) of modulo 4 index (0, 3, 3, 2) respectively, in the case of a RCT system using Nyquist shaping.

It shall be noted this organization is equivalent to the one produced in the case of rectangular shaping, except each mini-burst is preceded by a Nyquist preamble and closed by a Nyquist postamble.

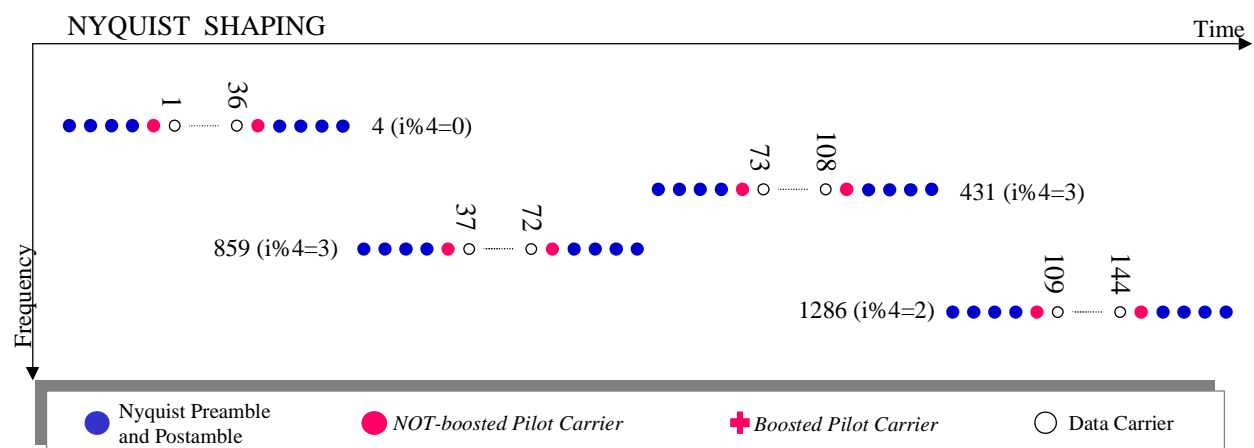

Figure 26: BS1 with frequency hopping and Nyquist shaping

The frequency hopping law for the 2K mode shall be as defined in the table 16.

Table 16: Frequency Hopping Law for 2K mode

Subchannel For $2 \leq \text{SCN} \leq 428$	Subchannel For $429 \leq \text{SCN} \leq 855$	Subchannel For $857 \leq \text{SCN} \leq 1\ 283$	Subchannel For $1\ 284 \leq \text{SCN} \leq 1\ 710$
Carrier SCN	Carrier SCN	Carrier SCN	Carrier SCN
Carrier SCN+855	Carrier SCN+855	Carrier SCN-428	Carrier SCN-1 282
Carrier SCN+427	Carrier SCN-427	Carrier SCN+427	Carrier SCN-427
Carrier SCN+1 282	Carrier SCN+428	Carrier SCN-855	Carrier SCN-855

The frequency hopping law for 1K mode shall be as defined in the table 17.

Table 17: Frequency Hopping Law for 1K mode

Subchannel For $1 \leq \text{SCN} \leq 210$	Subchannel For $211 \leq \text{SCN} \leq 420$	Subchannel For $422 \leq \text{SCN} \leq 631$	Subchannel For $632 \leq \text{SCN} \leq 841$
Carrier SCN	Carrier SCN	Carrier SCN	Carrier SCN
Carrier SCN+421	Carrier SCN+421	Carrier SCN-211	Carrier SCN-631
Carrier SCN+210	Carrier SCN-210	Carrier SCN+210	Carrier SCN-210
Carrier SCN+631	Carrier SCN+211	Carrier SCN-421	Carrier SCN-421

6.10.2 Burst Structure 2 (BS2) definition

Burst Structure 2 (BS2) shall carry 144 data symbols organized in four mini-bursts, each transmitted on a separate carrier. The four mini-bursts are transmitted simultaneously. The four used carriers constitute a Sub-Channel.

The Sub-Channel shall be defined according to the usage of BS2 in either Medium Access Scheme 2 (MAS2 - see clause 6.10.2.1) or in Medium Access Scheme 3 (MAS3 - see clause 6.10.2.2).

Data mapping shall be done sequentially, after encoding, interleaving and conversion of the binary stream to constellation signals, onto the 4 mini-bursts.

The pilot insertion scheme used for BS2 is identical to that of BS1, and is illustrated in figure 27.

The pilot insertion scheme selected for the transmission of a mini-burst is only dependant on the location ($i \text{ Modulo } 4$) of the carrier (i) over which the mini-burst is transmitted within the multiplex of useful carriers.

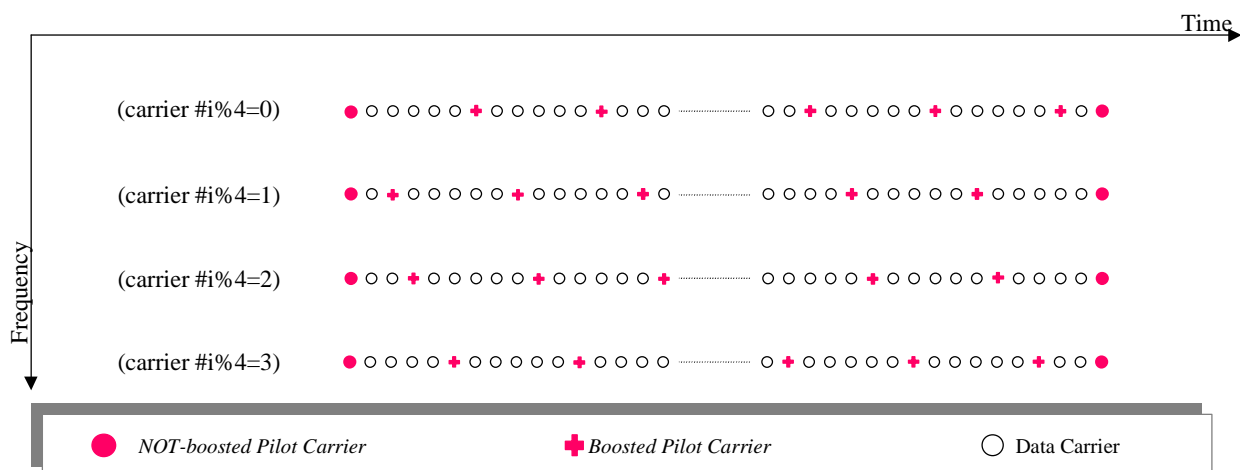

Figure 27: Pilot insertion scheme for the BS2 mini-bursts

Figure 28 illustrates a BS2 transmitted over 4 carriers of modulo 4 index (0; 1; 2; 3) respectively, using either Rectangular window shaping or Nyquist shaping.

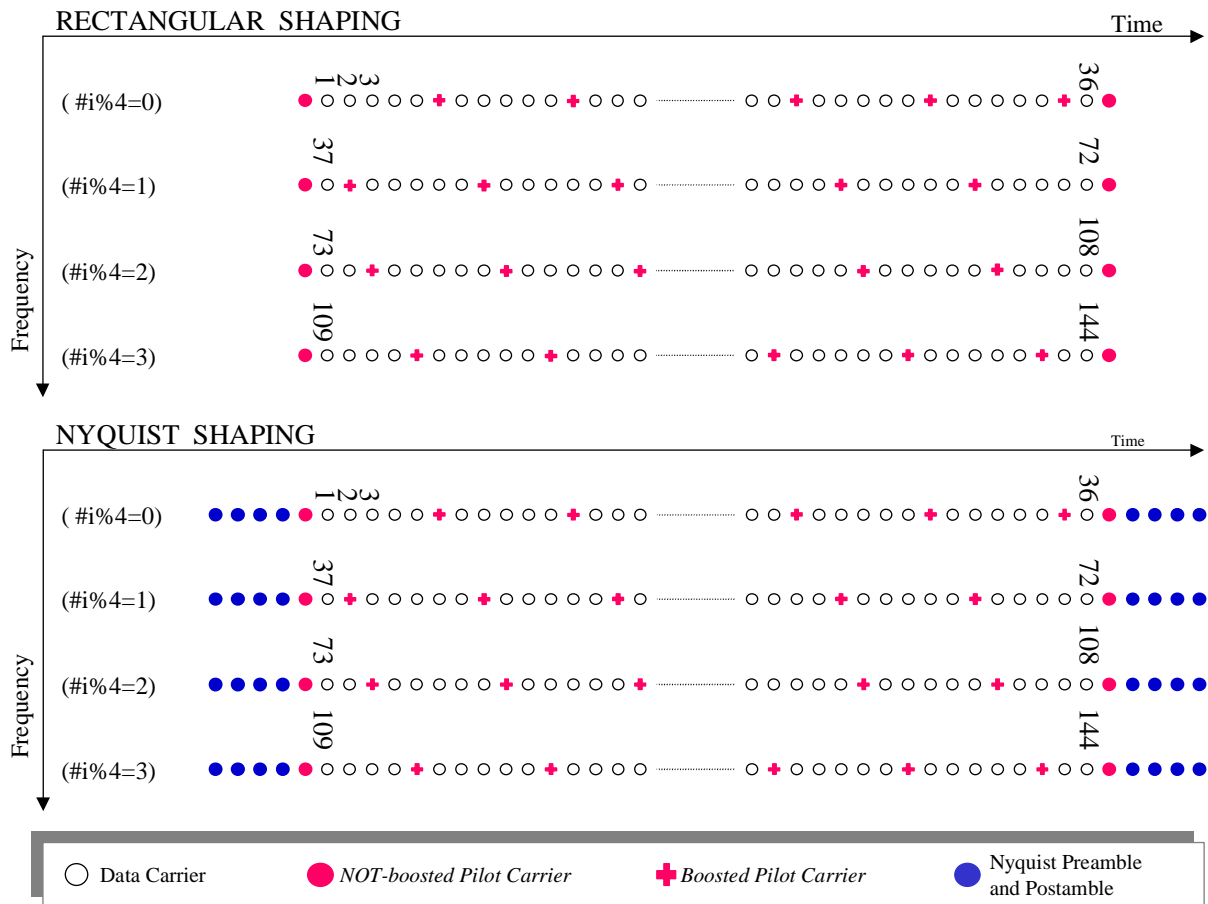

Figure 28: BS2 with Rectangular and Nyquist shaping

The BS2 carrier allocation shall follow the parameters given in table 18.

Table 18: BS2 Sub-Channel parameters for Rectangular and Nyquist shaping

	Rectangular	Nyquist
Data Symbols	144	144
Pilot Symbols	36	36
Null pre- and post-amble symbols	0	4 × 8
User Total number of Symbols	176	208
Total number of Symbols per carrier in one Sub-channel allocation	45	53

6.10.2.1 Carrier Allocation for Medium Access Scheme 2

When using Medium Access Scheme 2 (MAS2 - see clause 6.11.2) the allocation of 4 carriers to a Sub-Channel shall follow the values given in table 19 (i.e. the DC carrier is excluded for RF simplicity).

Table 19: BS2 Sub-Channel allocation parameters when using Medium Access Scheme 2

	2K mode	1K mode
Number of carriers in one OFDM symbol	2 048	1 024
Overall Carriers	1 712	842
Carrier numbering	0..1 711	0..841
Left side Guard Band	168	91
Right side Guard Band	168	91
Excluded carrier number	0, 1, 856, 1 711	0, 421
Sub-Channel Numbering: SCN	2..428	1..210
X	427	210
Y	855	421
Z	1 282	631

The next formulas define the carrier indexing within a Sub-Channel allocation for 2K and 1K modes:

$$\text{Carrier\#0} = \text{SCN}$$

$$\text{Carrier\#1} = \text{SCN} + X$$

$$\text{Carrier\#2} = \text{SCN} + Y$$

$$\text{Carrier\#3} = \text{SCN} + Z$$

6.10.2.2 Carrier Allocation for Medium Access Scheme 3

When using Medium Access Scheme 3 (MAS3 - see clause 6.11.3), the allocation of 4 carriers to a Sub-Channel is done by allocating a Sub-Set of carriers within a BS3 Sub-Channel.

Each Sub-Channel in BS3 contains 29 carriers, these can then be divided into 7 Sub-Sets of 4 carriers each, and one remaining carrier which is not used.

The carriers within a Sub-Channel of BS3 are numbered from 0 to 28. The allocation of carriers to Sub-Sets of BS2 is done by the next formula:

$$\text{SubSet\#}(\text{SCN}, n) = \text{Carrier\#}(n-1), \text{Carrier\#}(n+6), \text{Carrier\#}(n+13), \text{Carrier\#}(n+20)$$

where n denotes the Sub-Set number for BS2 Sub-Channel allocation within the SCNth BS3 Sub-Channel allocation.

As defined in clause 6.10.3, the numbering of Sub-Channels for BS3 is done in multiples of 10 in order to leave room for the BS2 Sub-Channel numbering when using MAS3.

The Sub-Channel numbering in this case depends on the SCNth BS3 Sub-Channel used to produce the nth BS2 Sub-Channels.

The following formula and the values given in table 20 shall be used to assign Sub-Channel numbering:

$$\text{BS2SubChannel\#} = \text{SCN} + n,$$

$$1 \leq n \leq 7$$

Table 20: BS2 Sub-Channel allocation parameters, when using MAS3 (Rectangular shaping only)

	2K mode	1K mode
Number of carriers in one OFDM symbol	2 048	1 024
Sub-Channel Numbering: BS2SubChannel#	1..7, 11..17, 21..27, ..581..587	1..7, 11..17, 21..27, ..281..287

6.10.3 Burst Structure 3 (BS3) definition

Burst Structure 3 (BS3) shall carry 144 useful data symbols transmitted over twenty-nine carriers. This group of 29 carriers is called a Sub-channel.

BS3 shall be used only in case of Rectangular shaping.

The pilot insertion scheme for BS3 is illustrated in figure 29.

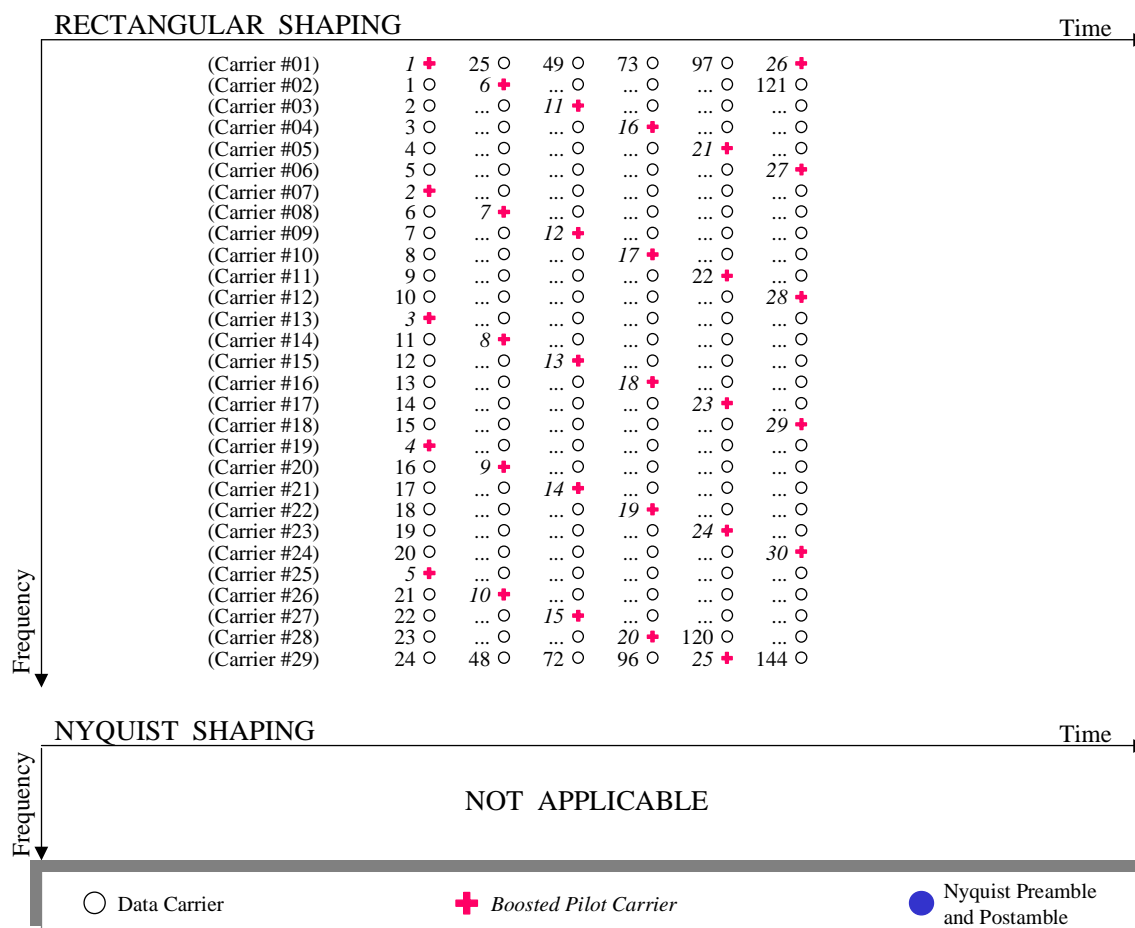

Figure 29: Illustration of BS3 structure

Data mapping shall be done sequentially, after encoding, interleaving and conversion of the binary stream to constellation signals, onto the Sub-Channel allocated to the BS3 burst.

BS3 shall use the time-domain parameters defined in table 21.

Table 21: BS3 time-domain parameters (Rectangular shaping only)

	Rectangular	Nyquist
Data Symbols	144	Not applicable
Pilot Symbols	30	Not applicable
User Symbols	174	Not applicable
Total number of OFDM symbols in one allocation	6	Not applicable

BS3 shall use the frequency-domain parameters defined in table 22.

Table 22: BS3 frequency-domain parameters (Rectangular shaping only)

	2K mode	1K mode
Number of carriers in one OFDM symbol	2 048	1 024
Overall Carriers	1 712	842
Carrier numbering	0..1 711	0..841
Left side Guard Band	168	91
Right side Guard Band	168	91
Excluded carrier number (DC)	856	421
Number of Sub-Channels	59	29
Sub-Channel Numbering: SCN	0, 10, 20, 30, ..580	0, 10, 20, 30, ..280

The allocation of carriers to BS3 Sub-Channels is defined in clause 6.11.3.1 for the 2K mode and in clause 6.11.3.2 for the 1K mode.

Note that the numbering of the Sub-Channels is done in multiples of 10 in order to allow the numbering of BS2 Sub-Channels within the BS3 Sub-Channels for Medium Access Scheme 3, as described in clause 6.10.2.2.

6.11 Medium Access Schemes

The DVB-RCT standard offers two transmission frame structures (see clause 6.3.2) and three Burst Structures (see clause 6.10). Medium Access Schemes provide the mapping of one or more Burst Structures on a particular transmission frame. Three Medium Access Schemes are defined:

- Medium Access Scheme 1 (MAS1) is used exclusively to map Burst Structure 1 (BS1) onto transmission frame one;
- Medium Access Scheme 2 (MAS2) is used exclusively to map Burst Structure 2 (BS2) onto transmission frame one;
- Medium Access Scheme 3 (MAS3) is used to map Burst Structure 3 (BS3) and optionally, Burst Structure 2 (BS2) onto transmission frame two.

For all Burst Structures, the Base Station controls the number of Sub-Channels allocated simultaneously to a given RCTT with the following limitations:

- For Nyquist shaping no more than 64 Sub-Channels shall be allocated to a given RCTT. Moreover, when several Sub-Channels are allocated, their Sub-Channel number shall be consecutive;
- For Rectangular shaping no more than 128 Sub-Channels using 64QAM modulation or 192 Sub-Channels using 16 QAM or 384 Sub-Channels using QPSK, shall be allocated to a given RCTT.

6.11.1 Medium Access Scheme 1

The number of used symbols, Data Symbols and synchronization symbols constituting the transmission frame for Medium Access Scheme 1, shall be compliant with the values given in table 23.

Table 23: BS1 Transmission frame parameters for Rectangular and Nyquist shaping

	Rectangular w/wo Frequency Hopping	Nyquist without Frequency Hopping	Nyquist with Frequency Hopping
User OFDM Symbols	180	188	212
OFDM Null Symbols	1	1	1
OFDM Ranging Symbols	6, 12, 24 or 48	6, 12, 24 or 48	6, 12, 24 or 48
Total number of time symbols in one Transmission frame	187, 193, 205 or 229	195, 201, 213 or 237	219, 225, 237 or 261

6.11.2 Medium Access Scheme 2

The number of used symbols, Data Symbols and synchronization symbols constituting the transmission frame for Medium Access Scheme 2, shall be compliant with the value given in table 24.

Table 24: BS2 Transmission frame parameters for Rectangular and Nyquist shaping

	Rectangular	Nyquist
User OFDM Symbols	176	208
OFDM Null Symbols	1	1
OFDM Ranging Symbols	6, 12, 24 or 48	6, 12, 24 or 48
Total number of time symbols in one Transmission frame	187, 193, 205 or 229	219, 225, 237 or 261

6.11.3 Medium Access Scheme 3

The number of used symbols, Data Symbols and synchronization symbols constituting the transmission frame usable for MAS3 shall be compliant with values given in table 25.

Table 25: Transmission frame parameters usable for MAS3 (Rectangular shaping case only)

	Rectangular with BS2	Rectangular with BS3
Modulated OFDM Symbols	44	48
OFDM Null Symbols	4	0
Number of BS in one transmission frame	1	8
OFDM Ranging Symbols	0 (see note)	0 (see note)
Total number of time symbols in one Transmission frame	48	48

NOTE: In MAS3, synchronization and ranging are provided using Sub-Channels (i.e. set of carriers) instead of using complete OFDM symbols.

The Medium Access Scheme 3 (MAS3) shall use only Rectangular shaping.

Figure 30 illustrates this combined usage of BS2 and BS3 allowed by MAS3.

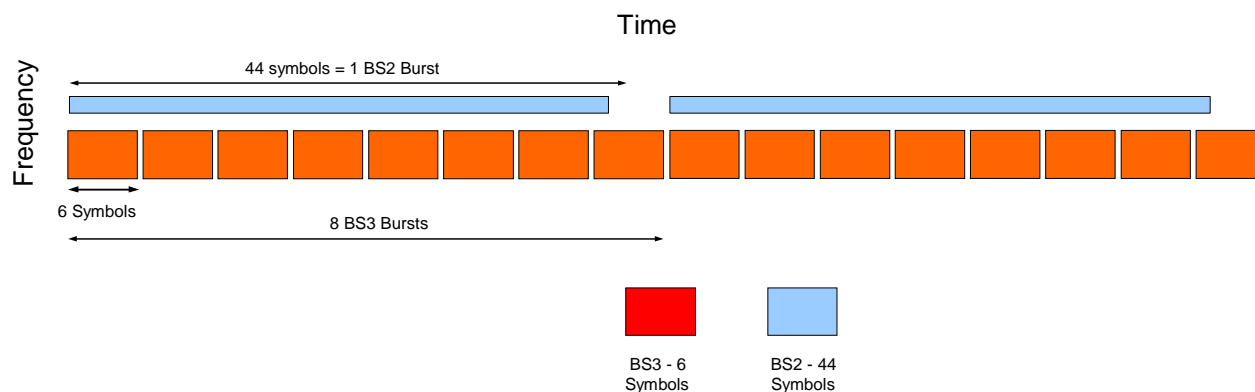

Figure 30: Transmission frame organization for MAS3

The start of a transmission frame used by MAS3 is defined as the start of a BS3 burst, which shall coincide with a start of a BS2 burst. The BS3 burst chosen as a start of transmission frame shall have a slot index number multiple of 8 (0, 8, 16, ...).

The start of a Ranging interval (see clause 6.12.3) shall coincide with the start of a BS3 burst.

6.11.3.1 Sub-channel format for 2K mode Structure

The allocation of carriers to Sub-Channels shall be computed using a permutation code, based upon the following series:

11, 3, 33, 9, 40, 27, 2, 22, 6, 7, 18, 21, 54, 4, 44, 12, 14, 36, 42, 49, 8, 29, 24, 28, 13, 25, 39, 16, 58, 48, 56, 26, 50, 19, 32, 57, 37, 53, 0, 52, 41, 38, 5, 55, 15, 47, 45, 23, 17, 10, 51, 30, 35, 31, 46, 34, 20, 43, 1

This series offers 59 different cyclic permutations. A new series is obtained by rotating the above basic series to the left. For instance, the first series obtained after one rotation will be:

3, 33, 9, 40, 27, 2, 22, 6, 7, 18, 21, 54, 4, 44, 12, 14, 36, 42, 49, 8, 29, 24, 28, 13, 25, 39, 16, 58, 48, 56, 26, 50, 19, 32, 57, 37, 53, 0, 52, 41, 38, 5, 55, 15, 47, 45, 23, 17, 10, 51, 30, 35, 31, 46, 34, 20, 43, 1, 11

To obtain a Sub-Set of 29 numbers, only the first 29 numbers of each permutation shall be taken. As for the series, up to 59 Sub-Sets of numbers can be obtained. For instance, for the above two series, the first two Sub-Sets will be the following:

11, 3, 33, 9, 40, 27, 2, 22, 6, 7, 18, 21, 54, 4, 44, 12, 14, 36, 42, 49, 8, 29, 24, 28, 13, 25, 39, 16, 58

3, 33, 9, 40, 27, 2, 22, 6, 7, 18, 21, 54, 4, 44, 12, 14, 36, 42, 49, 8, 29, 24, 28, 13, 25, 39, 16, 58, 48

To define a Sub-Channel formed by a carrier set of 29 carriers, the carriers shall be selected using the following formula:

$$\text{Carrier\#} = 59 \times n + (\text{Index}(n) + \text{Unique_Key}) \bmod 59$$

$$\text{AND If Carrier\#} \geq 856 \text{ then Carrier\#} = \text{Carrier\#} + 1$$

where:

- Carrier# denotes the carrier number in the Sub-Channel;
- n Index 0..28;
- Index(n) denotes the number having index n in the Sub-Set;
- Unique_Key denotes a key, provided by the MAC process, which will be unique to each Upstream Channel.

This procedure creates 59 Sub-Channels of 29 carriers each. These Sub-Channels are denoted as Carrier-Sets#J, where J ranges from 0 to 58.

6.11.3.2 Sub-channel format for 1K mode Structure

The allocation of carriers to Sub-Channels shall be computed using a permutation code, based upon the following series:

10, 13, 14, 24, 8, 22, 17, 25, 18, 6, 2, 20, 26, 28, 19, 16, 0, 15, 5, 21, 7, 12, 4, 11, 23, 27, 9, 3, 1

This series offers 29 different cyclic permutations. A new series is obtained by rotating the above basic series to the left. For instance, the first series obtained after one rotation of the basic series is:

13, 14, 24, 8, 22, 17, 25, 18, 6, 2, 20, 26, 28, 19, 16, 0, 15, 5, 21, 7, 12, 4, 11, 23, 27, 9, 3, 1, 10

To obtain a Sub-Channel formed by a carrier set of 29 carriers, the carriers shall be selected using the following formula:

$$\text{Carrier\#} = 29 \times n + (\text{Index}(n) + \text{Unique_Key}) \bmod 29$$

$$\text{If Carrier\#} \geq 421 \text{ then Carrier\#} = \text{Carrier\#} + 1$$

where:

- Carrier# denotes the carrier number in the Sub-Channel;
- n Index 0..28;

- Index(n) denotes the number having index n in the Sub-Set;
- Unique_Key denotes a key, provided by the MAC process, which will be unique to each Upstream Channel.

This procedure creates 29 Sub-Channels of 29 carriers each, these are denoted as Carrier-Sets#J, where J ranges from 0 to 28.

6.12 Ranging signal and structures

The MAC controller, located in the Base Station, shall synchronize each RCTT in Time, Power and possibly Frequency.

The present document provides Ranging codes, Ranging Sub-Channels and Ranging Procedures to provide such synchronization.

In order to be synchronized, any RCTT transmitting to the Base Station shall first transmit a Ranging Code over a Ranging Sub-Channel. This Ranging transmission shall be performed only on the Ranging Sub-Channel resources defined by the MAC process in the Base Station.

6.12.1 Ranging Sub-Channels Definition

In DVB-RCT systems, the ranging functions shall be performed using Ranging Codes of 145 bits (or 116 bits).

Ranging functions shall be implemented on specific Ranging Sub-Channels made up of 145 carriers (or 116 carriers).

For the 2K mode, the 59 Sub-Channels defined in clause 6.11.3.1 are used as follows to build up 12 Ranging Sub-Channels:

- the first 55 Sub-Channels form 11 Ranging Sub-Channels made up of 5 consecutive Sub-Channels each, which uses a total of 145 carriers;
- the 12th Ranging Sub-Channel is made up of the remaining 4 Sub-Channels, which uses a total of 116 carriers.

These Ranging Sub-Channels are numbered as Sub-Channel#n, where n ranges from 0 to 11.

For the 1K transmission mode, the 29 Sub-Channels defined in clause 6.11.3.2 are used as follows to build up 6 Ranging Sub-Channels:

- the first 25 Sub-Channels form 5 Ranging Sub-Channels made up of 5 consecutive Sub-Channels each, which uses a total of 145 carriers;
- the 6th Ranging Sub-Channel is made up of the remaining 4 Sub-Channels, which uses a total of 116 carriers.

These Ranging Sub-Channels are numbered as Sub-Channel#n, where n ranges from 0 to 5.

6.12.2 Ranging Sub-Channels Code Producer

The RCTTs need to access the Ranging Sub-Channels for various purposes:

- to synchronize to the DVB-RCT RF channel;
- to maintain their connection with the Base Station;
- to request additional bandwidth.

Such requests are addressed to the Base Station using the Ranging Sub-Channels and a dedicated Ranging Code.

A Ranging Code is formed by a series of 145 bits produced by the PRBS generator described in clause 6.8.3.

Only the first series of 96 codes, numbered 0..95, produced sequentially after the initialization of the PRBS generator, shall be used as Ranging Codes, as follows:

- the first 32 codes shall be used for Long Ranging (see clause 6.12.3);
- the next 32 codes shall be used for Short Ranging (see clause 6.12.5);

- the last 32 codes shall be used by a RCTT already connected to the system and asking for additional transmission resources.

It shall be noted that the last Ranging Sub-Channel has a reduced size of 116 carriers. When this Ranging Sub-channel has to be used, only the first 116 bits (instead of the 145 bits) of the Ranging Code produced shall be modulated.

The relevant Ranging Code shall be modulated onto a Ranging Sub-Channel as described in clause 6.8.3.

6.12.3 Ranging Interval

In any Medium Access Scheme the Ranging interval has a duration of 6 OFDM symbols.

For MAS3, the Ranging interval shall start on the same OFDM symbol as a BS3 burst starts.

In MAS1 and MAS2, Short and Long Ranging transmission shall be performed on different Ranging Sub-Channels.

In the case of Transmission Frame 1, the Base Station shall specify the number of consecutive Ranging intervals that are allocated.

Figure 31 illustrates this basic Ranging interval.

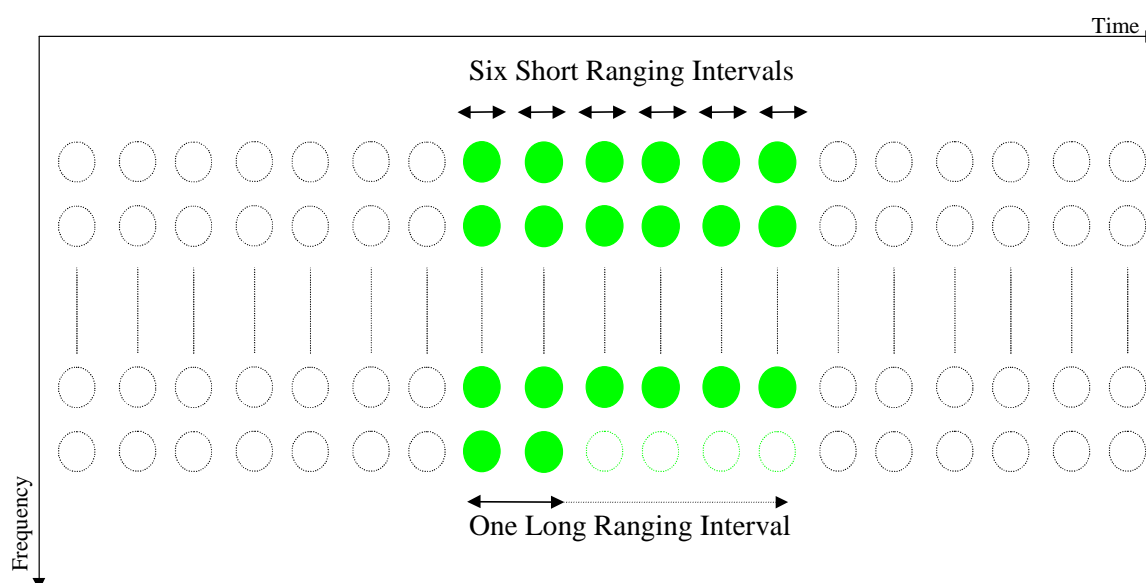

Figure 31: Basic Ranging Interval

6.12.4 Long Ranging transmission

The Long Ranging transmission shall be used by any RCTT that wants to synchronize to the RCT channel for the first time.

A Long Ranging transmission shall be performed during the two first consecutive symbols, out of the six available ranging symbols, in a dedicated Ranging Sub-Channel. The remaining four ranging symbols shall not be used.

Using one Ranging Code (see clauses 6.12.2 and 6.8.3), the RCTT shall modulate continuously the 145 carriers (or 116 carriers) of the Ranging Sub-Channel, for a duration equal to the sum of the two Ranging Intervals including the two guard interval durations. There shall not be any phase discontinuity on the Ranging Sub-Channel carriers during the period of the Long Ranging transmission.

This Long Ranging transmission is allowed only on the Ranging Sub-Channel resources defined by the MAC process in the Base Station.

6.12.5 Short Ranging transmission

The Short Ranging transmission shall be used only by a RCTT that has already synchronized to the RCT channel.

The Short Ranging transmission shall be used for system maintenance ranging or for bandwidth allocation requests.

To perform a Short Ranging transmission, the RCTT shall send one Ranging Code on one Ranging Sub-Channel. This transmission may occur on any OFDM symbol out of the six available ranging symbols.

This Short Ranging transmission is allowed only on the Ranging Sub-Channel resources defined by the MAC process in the Base Station.

6.13 Transmission capacities

6.13.1 Burst capacity and Bit Rates

The burst capacity is the number of useful bits per burst (N_U) after the error control decoding. This number depends upon the number of bits per symbol, provided by the M-QAM modulation scheme, and the error control coding, as described in the following relationship:

$$N_U = N_{b_Symb} \times \log_2(M) \times R$$

where N_{b_Symb} is the number of useful symbols per burst (144 symbols), M is the order of the M-QAM modulation and R is the used code rate.

Table 26 shows the burst capacity as a function of the three modulation schemes and the coding rate defined in the present document.

Table 26: Bitrate capacity per burst as a function of modulation scheme and coding rate

Modulation Scheme	Code Rate	Burst Capacity (bits)
QPSK	1/2	144
	3/4	216
16 QAM	1/2	288
	3/4	432
64 QAM	1/2	432
	3/4	648

The net bit rate per carrier is defined by the following equation:

$$\text{Bit rate per carrier} = 1/TS \times \log_2(M) \times R \times N_{b_Symb}/N_{tot_Symb}$$

where TS is the symbol duration and the N_{tot_Symb} is the total number of symbols per Burst Structures.

Table 27 resumes the User Symbols as a function of the burst structure in both case of Rectangular and Nyquist shaping, including the Frequency Hopping function applicable on BS1.

Table 27: Useful and total symbols as a function of burst structure and shaping scheme

Burst Structure	N_{b_Symb} (symbols)	Shaping scheme	N_{tot_Symb} (modulated symbols)
BS1	144	Rectangular	180 + 7
		Nyquist w/o FH	188 + 7
		Nyquist with FH	212 + 7
BS2		Rectangular	180 + 7
		Nyquist	212 + 7
BS3		Rectangular	174
	Nyquist	Not applicable	

The table 28 to table 31 show the physical net bit rate (kbit/s) per carrier for each transmission modes, using each Burst Structures mapped on Transmission Frame 1.

It shall be noted the following tables give the net bitrate per CARRIER. The whole bitrate capacity of the RCT channel shall be computed as a function of the total number of used carriers which itself depends on the mode in operation (see clause 6.2).

The same remark can be applied regarding the global bandwidth of the RCT channel which also depends on the RCT modes, as a function of the number of used carriers and the inter-carrier spacing (see clause 6.2).

Table 28: Physical net bit rate per carrier for BS1 or BS2 using Rectangular shaping

BS1 - Rectangular Shaping with or without Frequency Hopping Or BS2 - Rectangular Shaping			Guard Interval			
			1/4	1/8	1/16	1/32
CS1	4 QAM	1/2	0,688 kbit/s	0,764 kbit/s	0,809 kbit/s	0,833 kbit/s
		3/4	1,031 kbit/s	1,146 kbit/s	1,213 kbit/s	1,250 kbit/s
	16 QAM	1/2	1,375 kbit/s	1,528 kbit/s	1,618 kbit/s	1,667 kbit/s
		3/4	2,063 kbit/s	2,292 kbit/s	2,427 kbit/s	2,500 kbit/s
	64 QAM	1/2	2,063 kbit/s	2,292 kbit/s	2,427 kbit/s	2,500 kbit/s
		3/4	3,094 kbit/s	3,438 kbit/s	3,640 kbit/s	3,750 kbit/s
CS2	4 QAM	1/2	1,375 kbit/s	1,528 kbit/s	1,618 kbit/s	1,667 kbit/s
		3/4	2,063 kbit/s	2,292 kbit/s	2,427 kbit/s	2,500 kbit/s
	16 QAM	1/2	2,750 kbit/s	3,056 kbit/s	3,236 kbit/s	3,334 kbit/s
		3/4	4,125 kbit/s	4,584 kbit/s	4,853 kbit/s	5,000 kbit/s
	64 QAM	1/2	4,125 kbit/s	4,584 kbit/s	4,853 kbit/s	5,000 kbit/s
		3/4	6,188 kbit/s	6,875 kbit/s	7,280 kbit/s	7,501 kbit/s
CS3	4 QAM	1/2	2,750 kbit/s	3,056 kbit/s	3,236 kbit/s	3,334 kbit/s
		3/4	4,125 kbit/s	4,584 kbit/s	4,853 kbit/s	5,000 kbit/s
	16 QAM	1/2	5,500 kbit/s	6,112 kbit/s	6,471 kbit/s	6,667 kbit/s
		3/4	8,251 kbit/s	9,167 kbit/s	9,707 kbit/s	10,001 kbit/s
	64 QAM	1/2	8,251 kbit/s	9,167 kbit/s	9,707 kbit/s	10,001 kbit/s
		3/4	12,376 kbit/s	13,751 kbit/s	14,560 kbit/s	15,001 kbit/s

Table 29: Physical net bit rate per carrier for BS1 without Frequency Hopping, using Nyquist shaping

BS1 - Nyquist Shaping Without Frequency Hopping			$\alpha = 0,25$
CS1	4 QAM	1/2	0,659 kbit/s
		3/4	0,989 kbit/s
	16 QAM	1/2	1,319 kbit/s
		3/4	1,978 kbit/s
	64 QAM	1/2	1,978 kbit/s
		3/4	2,967 kbit/s
CS2	4 QAM	1/2	1,319 kbit/s
		3/4	1,978 kbit/s
	16 QAM	1/2	2,637 kbit/s
		3/4	3,956 kbit/s
	64 QAM	1/2	3,956 kbit/s
		3/4	5,934 kbit/s
CS3	4 QAM	1/2	2,637 kbit/s
		3/4	3,956 kbit/s
	16 QAM	1/2	5,275 kbit/s
		3/4	7,912 kbit/s
	64 QAM	1/2	7,912 kbit/s
		3/4	11,868 kbit/s

Table 30: Physical net bit rate per carrier for BS1 with Frequency Hopping or BS2, using Nyquist shaping

BS1 - Nyquist Shaping - With Frequency Hopping Or BS2 - Nyquist Shaping			$\alpha = 0,25$
CS1	4 QAM	1/2	0,587 kbit/s
		3/4	0,881 kbit/s
	16 QAM	1/2	1,174 kbit/s
		3/4	1,761 kbit/s
	64 QAM	1/2	1,761 kbit/s
		3/4	2,642 kbit/s
CS2	4 QAM	1/2	1,174 kbit/s
		3/4	1,761 kbit/s
	16 QAM	1/2	2,348 kbit/s
		3/4	3,523 kbit/s
	64 QAM	1/2	3,523 kbit/s
		3/4	5,284 kbit/s
CS3	4 QAM	1/2	2,348 kbit/s
		3/4	3,523 kbit/s
	16 QAM	1/2	4,697 kbit/s
		3/4	7,045 kbit/s
	64 QAM	1/2	7,045 kbit/s
		3/4	10,568 kbit/s

Table 31: Physical net bit rate per carrier for BS3 using Rectangular shaping

BS3 - Rectangular Shaping			Guard Interval			
			1/4	1/8	1/16	1/32
CS1	4 QAM	1/2	0,684 kbit/s	0,760 kbit/s	0,805 kbit/s	0,829 kbit/s
		3/4	1,026 kbit/s	1,140 kbit/s	1,207 kbit/s	1,243 kbit/s
	16 QAM	1/2	1,368 kbit/s	1,520 kbit/s	1,609 kbit/s	1,658 kbit/s
		3/4	2,052 kbit/s	2,280 kbit/s	2,414 kbit/s	2,487 kbit/s
	64 QAM	1/2	2,052 kbit/s	2,280 kbit/s	2,414 kbit/s	2,487 kbit/s
		3/4	3,078 kbit/s	3,419 kbit/s	3,621 kbit/s	3,730 kbit/s
CS2	4 QAM	1/2	1,368 kbit/s	1,520 kbit/s	1,609 kbit/s	1,658 kbit/s
		3/4	2,052 kbit/s	2,280 kbit/s	2,414 kbit/s	2,487 kbit/s
	16 QAM	1/2	2,736 kbit/s	3,040 kbit/s	3,218 kbit/s	3,316 kbit/s
		3/4	4,103 kbit/s	4,559 kbit/s	4,827 kbit/s	4,974 kbit/s
	64 QAM	1/2	4,103 kbit/s	4,559 kbit/s	4,827 kbit/s	4,974 kbit/s
		3/4	6,155 kbit/s	6,839 kbit/s	7,241 kbit/s	7,461 kbit/s
CS3	4 QAM	1/2	2,736 kbit/s	3,040 kbit/s	3,218 kbit/s	3,316 kbit/s
		3/4	4,103 kbit/s	4,559 kbit/s	4,827 kbit/s	4,974 kbit/s
	16 QAM	1/2	5,471 kbit/s	6,079 kbit/s	6,437 kbit/s	6,632 kbit/s
		3/4	8,207 kbit/s	9,119 kbit/s	9,655 kbit/s	9,947 kbit/s
	64 QAM	1/2	8,207 kbit/s	9,119 kbit/s	9,655 kbit/s	9,947 kbit/s
		3/4	12,310 kbit/s	13,678 kbit/s	14,482 kbit/s	14,921 kbit/s

6.13.2 Transmission frame duration

Table 32 resumes the consecutive OFDM Symbols Number in each transmission frames (including data symbols, physical overhead symbols and ranging symbols) as a function of the burst structure in cases of Rectangular shaping and Nyquist shaping.

Table 32: Consecutive OFDM Symbols Number in transmission frame as a function of burst structure and shaping scheme (n = 1 or 2 or 4 or 8 for the number of ranging interval)

Burst Structure	N_b -Symb (symbols)	Shaping scheme	N_{tot} -Symb (modulated symbols)
BS1 (TF1)	144	Rectangular	$180 + 1 + 6 \times n$
		Nyquist w/o FH	$188 + 1 + 6 \times n$
		Nyquist with FH	$212 + 1 + 6 \times n$
BS2 (TF1)		Rectangular	$180 + 1 + 6 \times n$
		Nyquist	$212 + 1 + 6 \times n$
BS3 (TF2)		Rectangular	174
	Nyquist	Not applicable	

The time duration of a transmission frame depends of the number of consecutive OFDM symbols and of the time duration of the OFDM symbol.

The time duration of an OFDM symbol depends on:

- the reference system clock (64/7 MHz or 56/7 MHz or 48/7 MHz);
- the carriers spacing (CS1, CS2, and CS3); and
- for the rectangle filtering of the Guard Interval (1/4, 1/8, 1/16, 1/32).

Some values are given in table 33.

Table 33: Transmission frames time duration (s) for rectangle filtering with GI = 1/4 or Nyquist Filtering and for reference clock 64/7 MHz (n = 1)

Burst Structure	Shaping scheme	Number of Consecutive OFDM Symb	CS1	CS2	CS3
TF1-BS1	Rectangular	187	0,209 44	0,104 72	0,052 36
	Nyquist w/o FH	195	0,218 4	0,109 2	0,054 6
	Nyquist with FH	219	0,245 28	0,122 64	0,061 32
TF1-BS2	Rectangular	187	0,209 44	0,104 72	0,052 36
	Nyquist	219	0,245 28	0,122 64	0,061 32
TF2-BS3	Rectangular	174	0,194 88	0,097 44	0,048 72
	Nyquist	Not applicable			

6.14 Modulator Performance

6.14.1 Modulator Signal performance

The requirement on the power profile for the Nyquist shaping is defined by the spectral mask for an individual modulated carrier (shifted to base-band) as indicated in table 34.

Table 34: Upstream transmitter power profile (Nyquist shaping)

$ f $	Power Spectrum
Under $0,375/T_s$	$0 \pm 0,5$ dBc/Hz
at $0,5/T_s$	$-3 \pm 0,25$ dBc/Hz
at $0,625/T_s$	< -35 dBc/Hz
at $1,25/T_s$	< -45 dBc/Hz
for $1,25/T_s < f < 15 \times 1,25/T_s$	20 dB/decade decreasing until the noise floor
Above $15 \times 1,25/T_s$ (Noise floor)	< -69 dBc/Hz

The requirement on the power profile for the Rectangular shaping is defined by the spectral mask for an individual modulated carrier (shifted to base-band) as indicated in table 35.

Table 35: Upstream transmitter power profile (Rectangular shaping)

$ f $	Power Spectrum
0	0 dBc/Hz
at $1/T_s$	< -60 dBc/Hz
$1/T_s < f < 10/T_s$	Lobe profile: 20 dB/decade decreasing until the noise floor
above $15 \times 1/T_s$ at n/T_s	< -69 dBc/Hz

6.14.2 Modulator Switching performance

The minimum bounds on the VHF/UHF return channel modulator's switching performance are summarized in figure 32.

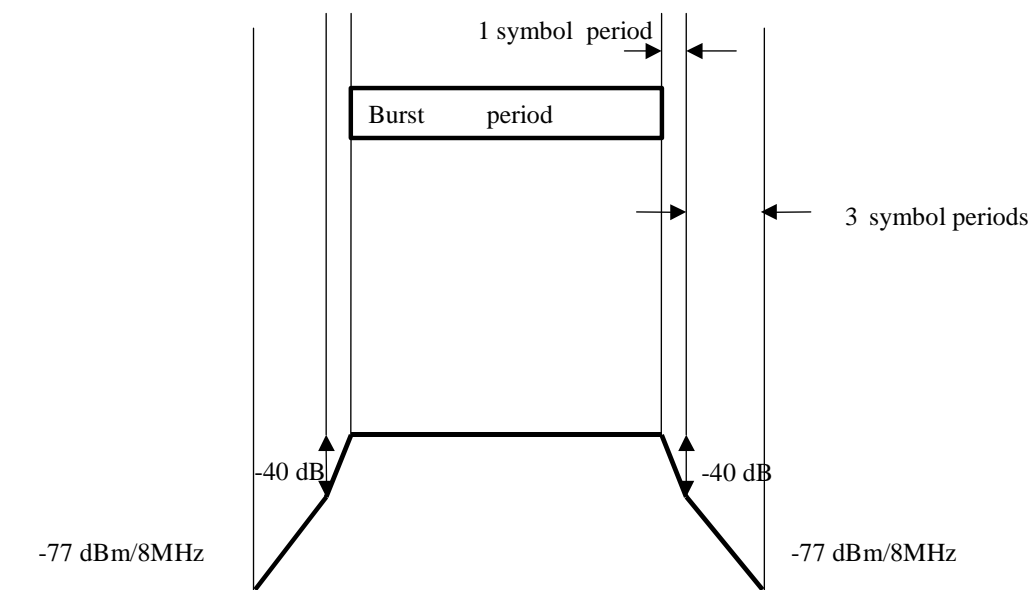
**Figure 32: Switching performance of the UHF return channel modulator**

6.14.3 Spectrum mask

The transmitted maximum spurious out-of-band power (given at the antenna port) should be within the profile shown in figure 33. It was designed to ease sharing between digital TV reception and RCT transmissions.

Transmission configuration is preferably set to CS1, 8 MHz, (i.e. $C_s = 1,116$ kHz). Measurement bandwidth reference is 1 kHz; the power reference at antenna port (after duplexer) being +20 dBm total power (see annex B), channelling is 8 MHz, F0 centre.

The spectrum mask is detailed in three parts:

1) In-band (Tx segment)

This is the spurious emissions falling within the wanted transmission band due to modulation and multicarrier intermodulation.

For single carrier transmission (BS1) $\Delta F1 = 0,375/T_s$ and $\Delta F2 = 1,25 \times 15/T_s (\approx 15 \times C_s)$ are mode dependant (see clause 6.4). A minimum 69 dBc rejection is asked at $\Delta F2$, 90 dBc at $F0 + 1$ MHz, and 100 dBc at $F0 + 4$ MHz.

For multicarrier transmission BS2, 3, a 30 dBc cumulated intermodulation rejection is required on the edge of the pool of adjacent carriers (power reference at 0 dBc - $10 \times \text{Log}(\text{Number of carriers})$).

For e.g. BS3 power ref = -15 dBc, mask -45 dBc at $\Delta F2$, -55 dBc at $2 \times \Delta F2$, -90 dBc at $F0 + 1$ MHz.

2) Duplex Distance guard band

It is the minimum bandwidth separating the transmission band from the receiving band i.e. the closest received DVB-T channel. The guard bandwidth is matter of the duplex distance (D_u), which depends from the chosen non-interference criteria and filtering technology (see annexes).

3) Out-of-band (Rx segment)

In the Rx segment, the remaining noise contribution from the transmitted signal should not degrade the DVB-T noise floor by no more than 3 dB; it leads to a -137 dBm/kHz tolerable additional noise contribution at the receiver input. Adding +20 dB duplexer ports isolation, the level becomes -117 dBm/kHz at the Tx port which is -137 dBc/kHz at +20 dBm power.

For separate antennas, the minimum 20 dB isolation is maintained (equivalent to one UHF wave length separation for 2 dipole antennas).

For a switched duplexer, the isolation between Rx and Tx ports becomes infinite, the mask should then follow at least the -100 dBc line.

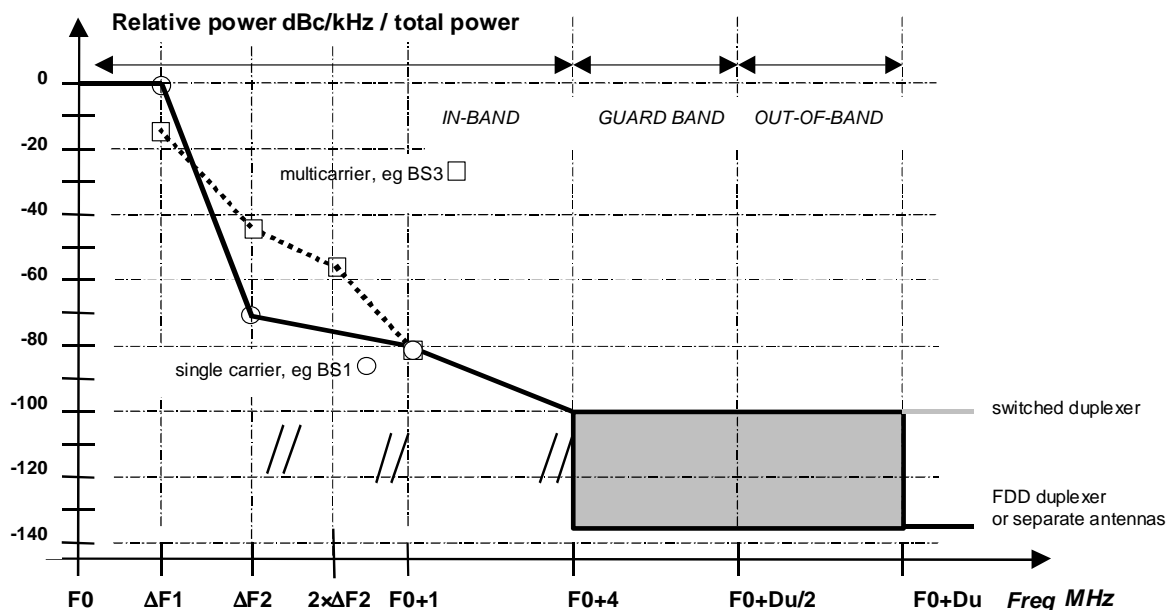

Figure 33: RF transmission power mask

Remarks

The given mask assumes reception of DVB-T signals at system thresholds. Relaxation of the mask specification is possible by considering higher noise floor degradation (which increases minimum field strength requirements) or fixed filter technology, also any improvement on the DVB-T (BIM) tuner (input tracking filter, IP figures, etc.).

6.14.4 Time and Frequency Accuracy

6.14.4.1 Frequency accuracy

The requirement for the accuracy of the VHF/UHF transmission frequency synthesis shall depend on the rate of Time/frequency synchronization references inserted as MPEG-TS packet, in the dedicated MPEG2-TS stream.

This accuracy shall be better than:

- 0,1 ppm for a 16 Hz insertion rate;
- 0,04 ppm for a 64 Hz insertion rate;
- 0,01 ppm for a 256 Hz insertion rate.

6.14.4.2 Time accuracy

The time synchronization to be applied on both burst and symbol synchronization shall be performed at user side with a accuracy better than $\pm 4 \mu\text{s}$, relatively to the ideal time synchronization and not taking into account any propagation delay from/to the Base Station.

7 Forward Interaction Path Specification

7.1 Downstream General Format

This clause defines the MAC frame integration into the forward path MPEG-2 TS stream.

The downstream data flow is defined as a continuous series of 188-byte MPEG_TS packets. These packets consist of a 4-byte header and a 1-byte pointer field followed by 183 bytes of payload.

Figure 34 shows the structure of the downstream MPEG-2 TS frame.

MPEG Header (4 bytes)	Pointer_field (1 byte)	MAC Payload (183 bytes)
--------------------------	---------------------------	----------------------------

Figure 34: MAC MPEG-2 TS Packet Structure

MPEG Header is the four byte MPEG-2 Transport Stream Header as defined in ISO/IEC 13818-1 [8] with a specific PID designated for MAC messages. This PID is 0x1C. The packet structure with PID MAC that is used is shown in figure 36. MSBs of each field are transmitted first, except the pointer field, which is, used LSB first.

Table 36: MAC MPEG2-TS Frame Structure

MAC MPEG2-TS Frame Structure()	Bits	Bytes	Bit Number/Description
MPEG2-Transport_packet_header	32	4	
Pointer_field	8	1	
While (Pointer_field == 184){			
Upstream_Synchronization_Field	56	7	
Pointer_field	8	1	
}			
If (Pointer_field <= 182){			
Start or continue or end of MAC message and/or stuff bytes			
}			
Else If (Pointer_field == 183){			
NULL Packet			
}			
Else{			
Non usable data			
}			
}			

Transport_packet_header: The transport_packet_header shall comply with ISO/IEC 13818-1 [8], clause 2.4.3.2, table 10 and table 11.

- The PID value for the downstream signalling is 0x1C;
- The payload_unit_start_indicator is not used by the RCT system and shall be set to 0;
- The transport_priority value is not used by the RCT system and shall be set to 0;
- The transport_scrambling_control value shall be set to 00 (not scrambled);
- The adaptation_field_control value shall be set to 01 (payload only).

All other parameters are according to ISO/IEC 13818-1 [8], clause 2.4.3.2.

Pointer_Field: The Pointer_Field is used to indicate the start of a MAC frame. Its value represents the number of bytes, including the Pointer_Field, that the NIU shall skip before looking for a new MAC packet. It is forbidden to insert a MAC message if there are less than 2 bytes left in the MPEG packet.

The Pointer_Field can have the following values:

- **00:** The MPEG packet contains only continuation of MAC frame from previous MPEG packet(s);
- **$1 \leq M \leq 182$:** The next MAC frame (or stuff bytes) begins at byte number M from the start of the pointer field (note 1);
- **M = 183:** NULL packet indicator, the MPEG packet following the pointer_field is a null packet (note 2);
- **M = 184:** The MPEG packet contains synchronization packet immediately following the pointer_field byte, the length of the synchronization packet is constant and defined in clause 7.2. In this case, another pointer_field will follow the synchronization packet. This value of the pointer field is the only one that allows cutting a MAC frame that spans multiple MPEG packets, in order to insert another MAC frame of superior priority;
- **M > 223:** The MPEG packet shall be ignored by the RCT MAC.

NOTE 1: In this case when $M > 1$, fragment of a previous MAC frame exists at the beginning of the MPEG packet.

NOTE 2: Using the pointer_field to indicate a null packet is useful in some cases when specific control information (like synchronization packet) has to be sent, but there is no other data to send, the null indication of the pointer_field used to optimize the parsing process of the receiver.

MAC frames may begin anywhere within an MPEG Packet, MAC frames may span MPEG packets, and several MAC frames may exist within an MPEG Packet.

Upstream_Synchronization_Field

The Upstream Synchronization Field is a 56-bit field, which provides upstream synchronization information.

Stuff_Byte

A stuff byte pattern of 0xFF is used within the MPEG payload to fill any gaps between the MAC frames.

Figure 35 shows a MAC Frame that is positioned immediately after the Pointer_Field byte. In this case, with Pointer_Field = 1, the NIU decoder begins searching for a valid MAC frame at the byte immediately following the Pointer_Field.

MPEG Header	Pointer_field (= 1)	MAC Frame (up to 183 bytes)	stuff_byte(s) (0 or more)
-------------	------------------------	--------------------------------	------------------------------

Figure 35: Packet format where a MAC Frame immediately follows the Pointer_Field

Figure 36 shows the case where a MAC Frame spans multiple MPEG packets. In this case, the Pointer_Field of the succeeding frame points to the byte following the last byte of the tail of the first frame.

MPEG Header	Pointer_field (= 1)	Stuff_byte(s) (0 or more)	Start of MAC Frame #1 (up to 183 bytes)	
MPEG Header	Pointer_field (= 0)	Continuation of MAC Frame # 1 (183 bytes)		
MPEG Header	Pointer_field (= M)	Tail of MAC Frame #1 (M-1 bytes)	stuff_byte(s) (0 or more)	Start of MAC Frame #2 (up to 183 - M-1 bytes)

Figure 36: Packet format where a MAC Frame spans multiple packets

Figure 37 shows the case where a synchronization packet is inserted into the MPEG packet. In this case, another pointer field exists after the synchronization packet and is used as in regular MPEG packets.

MPEG Header	Pointer_field (= 184)	Synchronization Packet (fixed size)	Pointer_field (≤ 182)	Start/Continue of Mac frame(s) and/or stuff bytes
-------------	--------------------------	--	---------------------------------	--

Figure 37: Synchronization packet inside the MPEG-2 TS packet

Figure 38 shows the case where a synchronization packet is inserted into the MPEG packet and no other MAC information is sent.

MPEG Header	Pointer_field (= 184)	Synchronization Packet (fixed size)	Pointer_field (= 183)	Non-Usable data
-------------	--------------------------	--	--------------------------	-----------------

Figure 38: Null MPEG packet with Synchronization prefix

7.2 Upstream Synchronization Field Format

The Upstream Synchronization Field is a 56-bit field, which provides upstream synchronization information. At least one MPEG packet with synchronization information shall be sent in every period of 62,5 ms (in case 16 Hz) or 15,625 ms (in case 64 Hz) or 3,906 25 ms (in case 256 Hz). The definition of the field is defined in table 37:

Table 37: Upstream Synchronization Field Format

Upstream_Synchronization_Field(){	Bits	Bytes	Bit Number/Description
Time_stamp_identifier	8	1	
Time_stamp	24	3	
Slot_Index	16	2	
CRC_8	8	1	
}			

Time_stamp_identifier

Time_stamp_identifier is an 8-bit unsigned integer representing the identifier of the time stamp. This identifier is defined in the <MAC> **Default Configuration Message** and is used by the RCTT to identify the synchronization field to use according to its upstream channel.

Time_stamp

Time_Stamp is an unsigned 24-bit field representing the time difference, expressed as a number of cycles ($4 \times$ the reference DVB-T clock), between the beginning of the next MPEG packet (i.e. beginning of the first bit of the next sync byte) and the beginning of the next US transmission frame start. The value of the time stamp shall be between the minimum value of $T_MPEGpacket_duration$ and the maximum value of: the transmission frame duration - $T_MPEGpacket_duration$ (with $T_MPEGpacket_duration$ the duration in number of cycle of 1 MPEG packet).

For the constant's values and meaning please refer to clause 6.4.

Slot_index

Slot_index is an unsigned 16-bit integer representing the slot number for the upstream transmission frame pointed by the time stamp. The RCTT shall increment the slot index value for each transmission frame when no upstream synchronization field is available.

CRC_8

CRC_8 is an unsigned 8-bit integer representing an 8-bits CRC with $X^8 + X^7 + X^6 + X^4 + X^2 + 1$ as polynomial sequence. The CRC is computed using the first six bytes of the synchronization field.

7.3 RCTT synchronization procedure

This clause defines the procedures to allow an RCTT to be connected to the Terrestrial interactive network and also how the terminal can disconnect from (or be disconnected by) the network.

7.3.1 Overall Events Sequencing

In order to be able to proceed in the RCT network, the RCTT shall be in the **Ready for ranging**, which is reached following the **Initial synchronization procedure** described in clause 7.3.1.1.

The entry of an RCTT into the system is then achieved through the following three phases:

- **Ranging synchronization procedure:** the RCTT improves its physical synchronization (frequency, time, and power adjustments) thank to ranging procedure with the base station;
- **Connected procedure:** the RCTT requests initial access to the network and gets initial connected information from the network (or alternatively the connected request may be rejected by the network);
- **Synchronization maintenance procedure:** the RCTT maintains its physical synchronization during the entire connected session.

Corresponding to the procedures, the RCTT can be in one of the following states:

- **Inactive (Off/Stand-by):** the RCTT is not powered or on a stand-by mode or has lost synchronization;
- **Receive sync:** the RCTT has acquired the forward link;
- **Ready for ranging:** the RCTT has been detected, and may initiate the ranging procedure;
- **Ready for initial connection:** the RCTT is synchronized and waits for a first connection;
- **Connected:** the RCTT is known by the base station and can send traffic.

The disconnect procedure described in annex E allows the RCTT to leave the network (also refer to annex E for the SDL diagram).

All the states, events, conditions and procedures are further described in this clause. The RCTT is not allowed to transmit data until it has reached the "Connected" state.

7.3.1.1 Initial synchronization procedure

Following the power-up, the RCTT shall proceed as detailed below:

- The RCTT shall first follow the procedures to receive and demodulate the DVB-T signal and to find all necessary control information related to the operation of the RCT network. This includes Upstream synchronization field, through which the RCTT initiates/lock its internal clock, and reach the required time and frequency accuracy (**initial synchronization procedure**);
- The RCTT shall continue to receive Upstream Synchronization field the throughout the session. In the event that transmission frame synchronization is lost, the RCTT ceases transmission and shall re-start the **initial synchronization procedure**. Similarly, any failure of the RCTT during one of the later-described procedures takes the RCTT back to the initial synchronization procedure.

After following these steps, the RCTT shall enter the **Ready for ranging** state.

7.3.1.2 Ranging synchronization procedure

Refer to clause 6.4.3 for a detailed explanation.

8 DVB-RCT MAC layer specifications

8.1 MAC Reference Model

The scope of this clause is limited to the definition and specification of the Medium Access Control (MAC) Layer protocol. The detailed operations within the MAC layer are hidden from the above layers.

This clause focuses on the required message flows between the INA and the NIU for Medium Access Control. These areas are divided into three categories: Initialization, Provisioning and Sign On Management; Connection Management; Link Management.

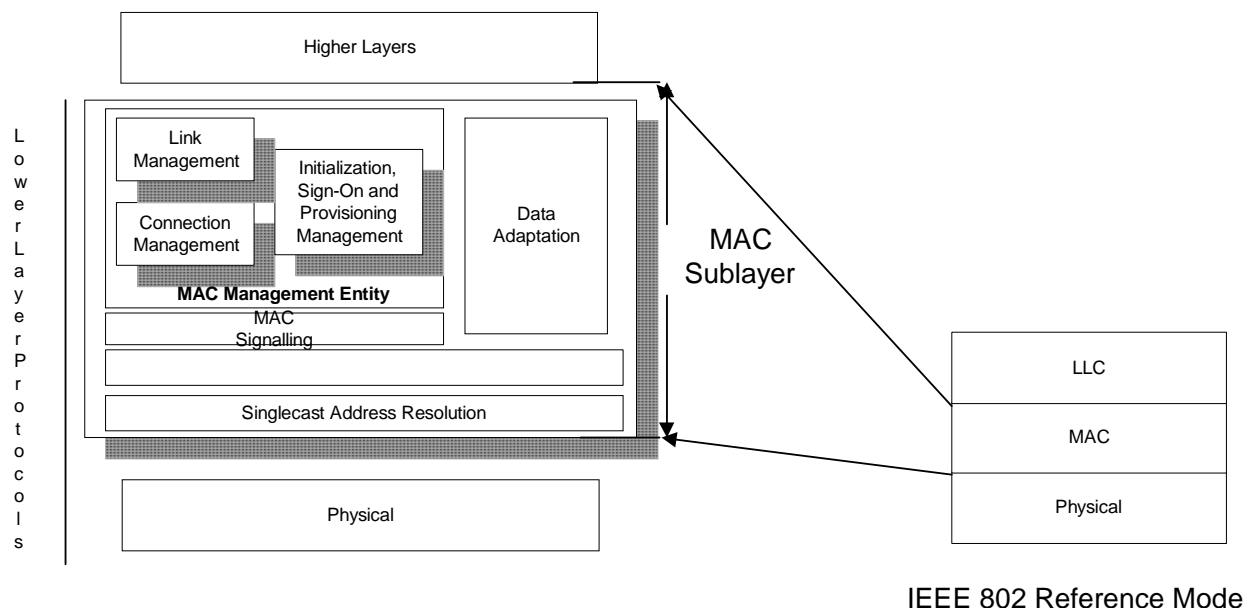

Figure 39: MAC Reference Model

8.1.1 MAC Concept

8.1.1.1 Relationship Between Higher Layers and MAC Protocol

The goal of the MAC protocol is to provide services to the higher layer protocols that enable transparent and independent control of the transmission and reception of data from the physical layer. Higher layer services are provided by the INA to the STU. The INA is thus responsible for indicating the transmission mode and rate to the MAC layer for each type of service. Specifically, for each connection provided by the higher layers on the INA side (VPI/VCI), a connection ID is associated at the MAC layer.

Specifically, for each connection provided by higher layers on the INA side (VPI/VCI), a connection ID is associated at the MAC layer. The maximum number of simultaneous connections that a NIU should support is defined as follows:

- Level A: Only one connection at a time can be handled by a NIU;
- Level B: As many connections as needed, defined dynamically by the INA, following higher layers requests.

NOTE 1: Note that in this case all connections shall be assigned to the same frequency upstream and downstream for implementation reasons.

NOTE 2: However bandwidth (time slots) does not need to be assigned immediately by the INA for a given connection. This means that a connection ID may exist at the NIU side without associated slot numbers.

The INA is responsible for providing transmission bandwidth to the NIUs when needed by higher layers. However, since the NIU shall transmit all data from the STU, the NIU is also responsible for requesting more bandwidth if not already provided by the INA.

An initial connection is allocated to the RCTT by the INA, following the successful completion of sign-on at power up. This connection can be used to send data from higher layers leading to further interactive connections. Note that this connection can be associated with a zero transmission rate (no initial bandwidth allocation).

8.1.1.2 Relationship Between Physical Layer and MAC Protocol

The upstream physical layer access method is based on the use of a combination of Time Division Multiple Access (TDMA) and Frequency Division Multiple Access (FDMA). In particular, the upstream is divided into a number of "time slots". Each time slot is then divided in the frequency domain into groups of carriers referred to as sub-channels. The MAC layer controls the assignment of sub-channels and time slots (by resource request and grant message).

Figure 40 illustrates this concept.

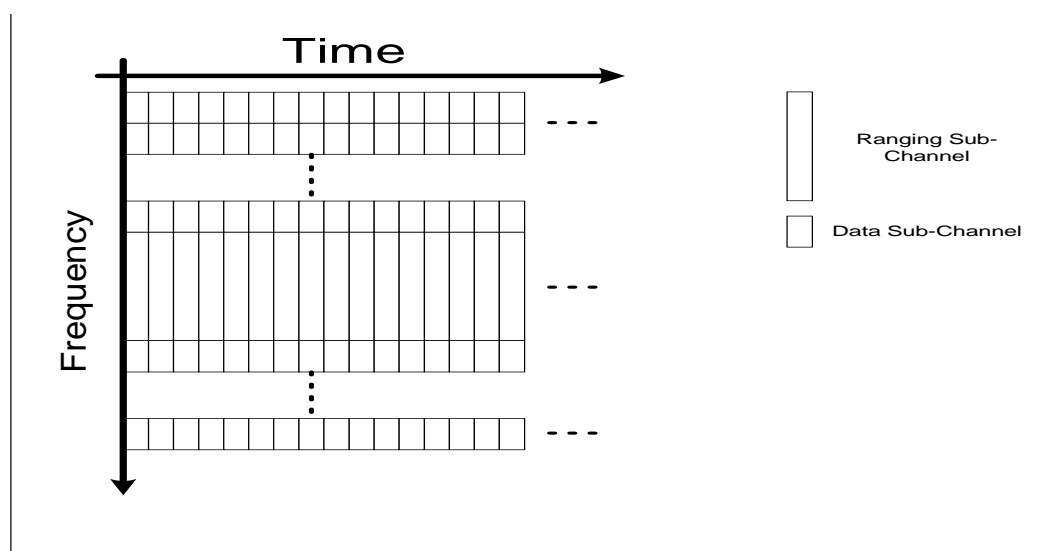

Figure 40: Example of frequency over time logical channels structure (TF2 case)

The Medium Access Control is carried out through messaging in a nominated downstream channel. The MAC protocol supports the possibility of multiple upstream channels within a cell. One of the available channels shall be used by NIUs as a service channel, which means that this channel will be used to enter the network via the ranging, sign-on and initialization procedures. The INA shall broadcast the parameters of the service channel in the **<MAC> Default Configuration Message**, the INA can change the service channel due to congestion or load-balancing reasons. The remaining upstream channels shall be used for upstream data transmission.

The Service channel is the frequency channel to which the default configuration message's Upstream_Channel_Frequency field points. The ranging following the reception of the **<MAC> Default Configuration Message** is carried out on that service channel. Once the NIU starts the sign-on process on a given service channel, it will complete all transactions on the same channel, even if the service channel was changed in subsequent **<MAC> Default Configuration Messages**.

All connections of an NIU are on the same upstream/downstream channels. The upstream and downstream channels can be changed by the **<MAC> Transmission Control Message** or the **<MAC> Reprovision Message**. If any of these messages contain a change in the upstream or downstream channel then the NIU shall move to the new channel immediately and shall maintain any existing connections on the new channel.

Sign-on procedure is entered immediately after the upstream or downstream channel change (assuming no Stop_Upstream_Transmission command was given in a previous **<MAC> Transmission Control Message**), all reservation grants are lost and fixed rate slots are maintained in the following circumstances:

- If the frequency change is made by the **<MAC> Transmission Control Message**, the fixed rate slot assignments remain the same;

- If the frequency change is made by the <MAC> **Reprovision Message** the fixed rate slot assignments remain the same except if new slot assignments are provided in the message.

When a Stop_Upstream_Transmission command is given, sign-on is performed after a Start_Upstream_Transmission command is received with reservation grants lost and fixed rate slots retained.

If any of the New_Upstream_Control_Field parameters are changed then reservation grants as well as fixed rate slots are lost but the connections are still retained.

8.1.1.3 Relationship Between Physical Layer Slot Position Counter and MAC Slot Assignment

The NIU shall deduce the time slot number from the downstream transmission. The time-slot is the basic time reference for slot allocation in the system and each of the NIUs in the system is synchronized with the INA.

Because each NIU can be at a different distance from the INA, each NIU shall be synchronized in time with the INA during the sign-on process.

8.1.1.4 Timing relationship between upstream and downstream MAC Messages

Any downstream MAC message, to which the RCTT is expected to react by the next time slot, shall be received in the first two-thirds of the current time slot.

Any downstream MAC message, implying from the RCTT a change of frequency or a change of physical parameters, shall be received at least one time slot before its application date.

8.1.2 Access Modes (Contention/Ranging/Fixed rate/Reservation)

The following rules define how to select access modes:

MAC messages:

MAC messages can be sent on contention access, reservation access, fixed rate access.

Note that the VPI/VCI = 0 × 00 / 0 × 0021 connection used for MAC messages is always set up, so the INA does not assign a particular connection ID which is normally used for reservation requests. Thus, in order to use reservation access, slots assigned for other connections may be used for MAC messages.

Data connections:

When the INA assigns a connection ID to the NIU (<MAC> **Connect Message**), it either specifies a slot list to be used (fixed rate access) or the NIU shall use contention or reserved access by using the following algorithm: if the NIU shall send more cells for a specific VPI/VCI than was assigned by the INA, it can use contention access only if the number of cells to transmit is less than Maximum_Contention_Access_Message_Length (specified in the <MAC> **Connect Message** from the INA).

The details of the contention access mechanism are explained below under item a).

The NIU can send one request for reservation access if the number of cells is less than Maximum_Reservation_Access_Message_Length (specified in the <MAC> **Connect Message** from the INA).

If more cells shall be transmitted, the NIU shall send multiple requests for reservation access.

If the NIU/RCTT is forced to use reservation access, and it has not yet been assigned a Reservation_ID, then it shall wait for an assignment before transmitting.

a) Contention Access

Contention access indicates that data (MAC or bursty data traffic) is sent in the unreserved slots identified by the <MAC> **Slot State Message**. It can be used either to send MAC messages or data. For modes with burst length smaller than ATM size only MAC messages (that fit in the burst) will be sent in contention. When the burst length is bigger than ATM size then ATM cells containing MAC or data messages shall be used for contention. The VPI, VCI of the ATM cells are then used to determine the type and direction of the data in higher layers. Contention based access provides instant channel allocation for the NIU.

The Contention based technique is used for multiple subscribers that will have equal access to the signalling channel. It is possible that simultaneous transmissions occur in a single slot, which is called a collision. The INA also uses the **<MAC> Slot State Message** to indicate when it has detected a collision.

The NIU executes a separate contention process for each VPI/VCI connection that requires contention access. The contention process is initiated by transmitting the first upstream packet in a contention slot. This contention slot is randomly chosen from the available contention slots. The contention process has to wait until the reception indicator of the slot is received (**<MAC> Slot State Message**). If the indicator contains a positive acknowledgement, the upstream packet has been successfully received (see note), and the next upstream packet, if present, can be transmitted by continuing the contention process. If the indicator contains a negative acknowledgement, a collision has been detected and the upstream packet can be retransmitted according to the procedure defined below. If the reception indicator is not received (e.g. due to transmission error), the NIU proceeds as if a positive acknowledgement would have been received.

NOTE: In some physical conditions, some collisions might not be correctly detected. It is left to higher layer protocols to handle such conditions.

If a collision has occurred the NIU is not obliged to retransmit the upstream packet that was originally transmitted. Instead it may choose to update the contents of the upstream packet, transmit another upstream packet belonging to the same VPI/VCI connection, or not to retransmit at all. In the latter case, the NIU is not allowed to restart a contention process for the same VPI/VCI connection at an earlier slot than the latest possible contention slot in which it could have retransmitted the upstream packet in the first contention process. Note that the allowed choices make it possible for the NIU to update the queue status when the upstream packet to be retransmitted is a grant request.

A counter at the RCTT records the number of collisions encountered by an upstream packet (denoted by the `backoff_exponent`). The `backoff_exponent` counter starts from a value determined by the `Min_Backoff_Exponent` variable. The `backoff_exponent` is used to generate a uniform random number between 1 and $2^{\text{backoff_exponent}}$. This random number is used to schedule retransmission of the collided upstream packet. In particular, the random number indicates the number of contention access slots the RCTT shall wait before it transmits. The first retransmission is carried out in the random contention slot once the RCTT has waited the required number of contention access slots. If the counter reaches the maximum number, determined by the `Max_Backoff_Exponent` variable, the value of the counter remains at this value regardless of the number of subsequent collisions. After a successful transmission the `backoff_exponent` counter is reset to a value determined by the `Min_Backoff_Exponent` variable. Informational Statement: The random access algorithm is unstable; the INA is expected to have intelligence to detect an unstable state of the random access algorithm and to solve it.

b) Ranging Access

Ranging access indicates that the NIU performs synchronization of power and time with the INA. Ranging access is performed on specially assigned slots (refer to clause 6.12) that are used only for this purpose. The NIU shall use Ranging access when entering to the network, moving to a new upstream channel or instructed to do so by the INA.

c) Fixed rate Access

Fixed rate access is provided by the INA using the **<MAC> Connect Message**. The INA is also allowed to assign slots in fixed rate access to a connection in response to a **<MAC> Reservation Request Message**. These slots are uniquely assigned to a connection by the INA.

d) Reservation Access

Reservation access is provided by the INA using the **<MAC> Reservation Grant Message**. These slots are uniquely assigned once to a connection by the INA. Requests are indicated via a request message in a contention slot, in a Ranging Slot, in a reserved slot, in a fixed rate slot or via the Piggybacking mechanism.

8.2 Overview of Cell Configurations for DVB-RCT

This clause provides examples of possible configurations of an upstream channel within a DVB-T cell. Real life scenarios can be derived from these basic examples. Several upstream channels can be used within one DVB-T cell and three examples are given below:

- 1) **One omnidirectional US channel:** the basic configuration with one US channel covering the whole DVB-T cell.

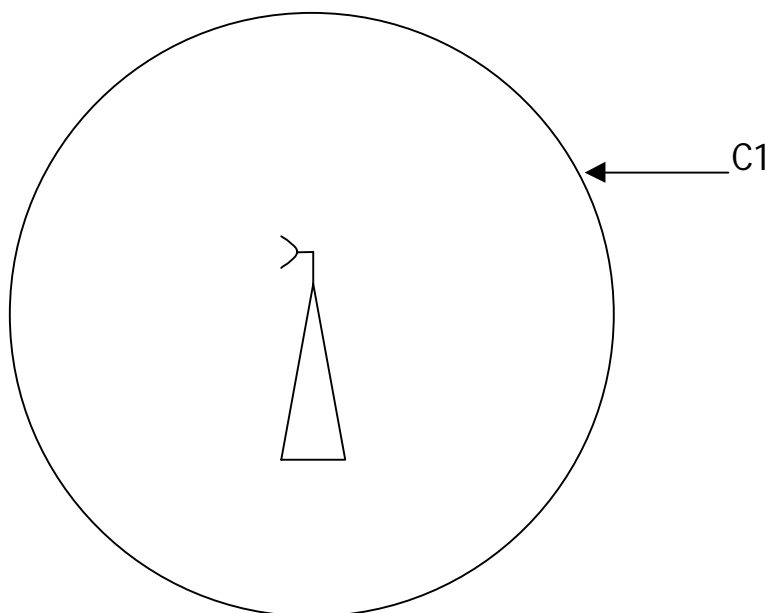

Figure 41: One US channel in a DVB-T cell

- 2) **Several omnidirectional US channels:** increased capacity can be achieved with several US channels.

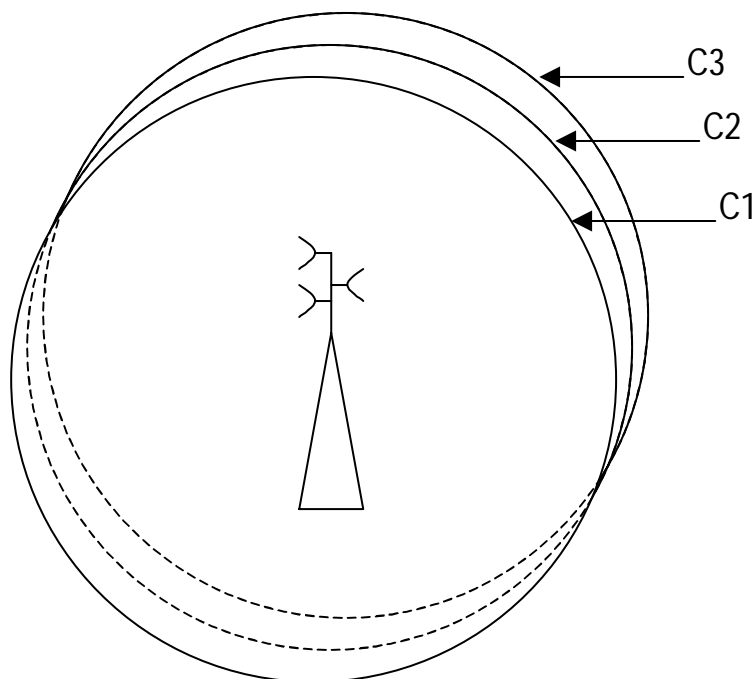

Figure 42: Several US channels in a DVB-T cell

3) Sectorization:

Sectorizing the DVB-T cell is a possibility that should be considered for the following reasons:

- mitigate against "jammers" and prevent interference: if an US channel is not available for use within the complete DVB-T cell coverage, it is possible to configure the cell with several US channels covering a sector each. In figure 43 C1.N are not available for use everywhere and are replaced by C3;
- increase the capacity by re-using the US channels. In figure 43, for example, C2 is re-used.

Inside one sector, several US channels could also coexist as in example 2.

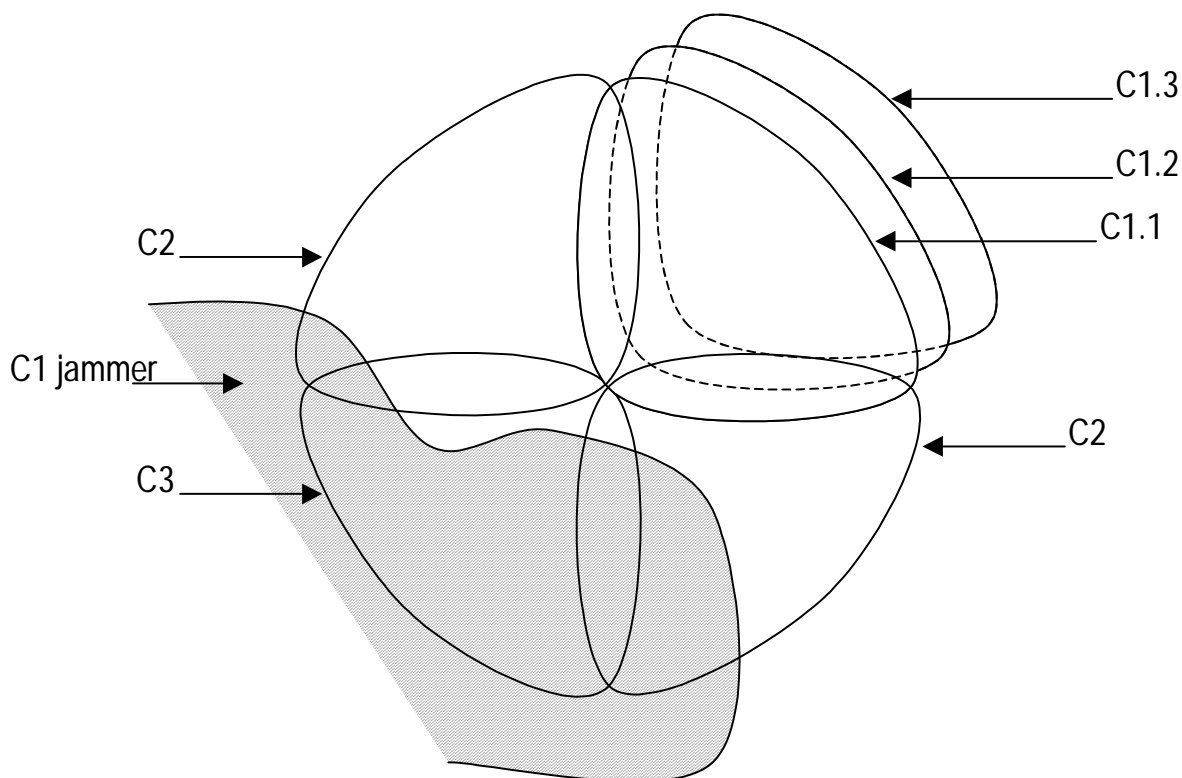

Figure 43: Sectoring a DVB-T cell; frequency re-use; minimizing interference; several US channels inside one sector

8.2.1 RCTT's Initialization and Sign On procedure

Once a RCTT is powered on, it shall attempt to initialize to the INA and lock on to the default provisioning channel (as contained in the <MAC> **Provisioning Channel Message**). Once locked on to the provisioning channel the RCTT will receive <MAC> **Default Configuration Messages** for all of the US channels configured in the cell. However, the RCTT will not know which is the best US channel to use so a basic mechanism is needed whereby the RCTT will try every US channel (in the cell) in sequence (at the same power). If no response is received from the INA then, the procedure is repeated with attempts to connect to the INA made at the next incremental power level for all US channels in the cell. This process is repeated for all power levels until a valid response is received. This could be time consuming in configurations with several US channels (as in figure 43 for example).

To avoid unnecessary delays some improvements can be achieved by defining a subset of US channels, called "service" channels, which can be used during the initialization procedure. This is possible in some configurations where several US channels have the same characteristics (coverage, physical etc.). For example, in figure 43, it is not necessary to try every C1.N US channel. Setting (see note) one of them as the service channel shortens the initialization time.

NOTE: Setting the msb of the US_Channel_Identifier sets the US channel as a "service" channel.

8.3 Upstream Message Format

MAC messages can be sent in ATM format or directly within a physical burst (see clause 6.7.2). The size of the burst will be variable with a minimum value of 18 bytes. Hence, the majority of MAC messages have been designed to fit within this minimum size including the 8-byte MAC header.

In the case of contention access, when the burst length is smaller than an ATM cell, MAC messages will be sent directly, when the burst length is bigger than an ATM cell, MAC messages will be sent encapsulated into ATM cells.

Data messages shall always be encapsulated in ATM cells.

8.4 Downstream Message Format

The Downstream MAC messages will be encapsulated into a continuous MPEG2-TS as defined in clause 7.

8.4.1 MAC Message Format

The MAC message types are divided into the logical MAC states of Initialization, Sign On, Connection Management and Link Management. MAC messages are sent using Broadcast or Singlecast Addressing. Singlecast addressing utilizes 48-bit MAC addressing.

Table 38: MAC messages

Message Type Value	MAC MESSAGES	Transmit Direction	Addressing Type
0x00-0x1F	MAC Initialization, Provisioning, Sign-On Messages		
0x00	Used for fragmented messages (continued message)	Upstream	Singlecast
0x01	(see note)	Downstream	Broadcast
0x02	Provisioning Channel Message	Downstream	Broadcast
0x03	Default Configuration Message		
0x04	[Not Used]	Upstream	Singlecast
0x05	Sign-On Message	Downstream	Scast/Bcast
0x06	Ranging and Power Calibration Message		
0x07	[Not used]	Downstream	Singlecast
0x08	Initialization Complete Message	Downstream	Broadcast
0x09-0x0B	Slot state Message		
0x0C	[Reserved]	Downstream	Singlecast
0x0D	Security Sign-on (see note)	Upstream	Singlecast
0x0E-0x1E	Security Sign-on Response (see note)		
0x1F	[Reserved] Wait (see note)	Upstream	Singlecast
0x20-0x3F	MAC Connection Establishment, Termination Messages		
0x20	Connect Message	Downstream	Singlecast
0x21	Connect Response Message	Upstream	Singlecast
0x22	Reservation Request Message	Upstream	Singlecast
0x23	[Not used]		
0x24	Connect Confirm Message	Downstream	Singlecast
0x25	Release Message	Downstream	Singlecast
0x26	Release Response Message	Upstream	Singlecast
0x28	Reservation Grant Message	Downstream	Broadcast
0x29	Reservation ID Assignment	Downstream	Singlecast
0x2A	Reservation Status Request	Upstream	Singlecast
0x2B	Reservation ID Response Message	Downstream	Singlecast
0x2C	Resource Request Message	Upstream	Singlecast
0x2D	Resource Request Denied Message	Downstream	Singlecast
0x2E-0x2F	[Reserved]		
0x30	Main Key Exchange (see note)	Downstream	Singlecast
0x31	Main Key Exchange Response (see note)	Upstream	Singlecast
0x32	Quick Key Exchange (see note)	Downstream	Singlecast
0x33	Quick Key Exchange Response (see note)	Upstream	Singlecast
0x34	Explicit Key Exchange (see note)	Downstream	Singlecast
0x35	Explicit Key Exchange Response (see note)	Upstream	Singlecast
0x36-0x3F	[Reserved]		

Message Type Value	MAC MESSAGES	Transmit Direction	Addressing Type
	MAC Link Management Messages		
0x27	Idle Message	Upstream	Singlecast
0x40	Transmission Control Message	Downstream	Scast/Bcast
0x41	Reprovision Message	Downstream	Singlecast
0x42	Link Management Response Message	Upstream	Singlecast
0x43	Status Request Message	Downstream	Singlecast
0x44	Status Response Message	Upstream	Singlecast
0x45	Configuration Message	Downstream	Scast/Bcast
0x46	Upstream_Contention_Optimized_Transmission_Window	Downstream	Broadcast
0x47-0x5F	(see note) [Reserved]		
NOTE: Optional MAC messages for the security option.			

To support the delivery of MAC related information to and from the NIU; a dedicated Virtual Channel is utilized. The VPI, VCI for this channel is 0x00/0x0021. MAC Messages are not encrypted. Therefore, any ATM cells carrying a MAC Message have the least significant two bits of its GFC field set to 00. The most significant two bits of the GFC field are reserved for future use, and are set to 00.

NOTE 1: Message_Type value of 0xFF is reserved and should not be used (used as a stuff byte in the downstream MPEG packet).

Upstream MAC messages:

AAL5 (as specified in ITU-T Recommendation I.363 [3]) adaptation is used to encapsulate each MAC PDU in an ATM cell.

Downstream MAC messages:

Downstream MAC messages are limited to a size of 1 500 bytes. No AAL5 layer is defined for MPEG-2 TS cells. MAC messages shall therefore be sent as explained in clause 8.4. The Downstream MAC messages are encapsulated within the MPEG-2 TS using the Pointer-Field.

Upstream MAC Fragmentation Protocol (optional):

Larger MAC messages of up to 512 bytes may optionally be supported using the MAC fragmentation protocol. This capability is indicated by the NIU in the MAC_Sign_OnMessage.

A multi-fragment MAC message is composed of consecutive individual MAC messages with Syntax_Indicator equal to Fragment_Message.

The Fragment_Count field of each individual MAC message indicates the number of fragments remaining of the full message, decreasing by one for each consecutive fragment. Thus the first fragment has Fragment_Count equal to the total number of fragments in the message, and the last fragment has Fragment_Count == 1.

Furthermore, the type of MAC message is indicated by the Message_Type field of the first fragment, whereas all subsequent fragments have Message_Type == 0.

The sender of a fragmented MAC message shall not interleave any other fragmented MAC message for the same receiver into the string of fragments.

The receiver of a fragmented MAC message (the INA) shall discard any message with missing fragments, as implied by the uniformly decreasing Fragment_Count field in consecutive fragments. Likewise, it shall discard any stray fragment with Message_Type == 0, for instance in the case where the first fragment was lost during transport.

The MAC_Information_Elements fields of each fragment are concatenated to form the MAC_Information_Elements field of the full MAC message. The message type is conveyed in the first fragment.

General MAC Format:

Since MAC related information is terminated at the NIU and INA, a privately defined message structure is utilized. The format of this message structure is illustrated below.

NOTE 2: All messages are sent most significant bit first (except as described in clause 7.1 for the pointer field).

NOTE 3: For all MAC messages where the parameter length is smaller than the field, the parameters are right justified with leading bits set to 0. All reserved fields in the MAC messages are set to 0.

NOTE 4: The messages tagged as "not used" shall not be used in the present release of the MAC protocol, the message id is kept for backward compatibility.

NOTE 5: When no MAC_Address is specified in the message, it means that the message is sent broadcast. (Syntax_indicator = 000).

NOTE 6: Negative integers are sent in 2's complement.

NOTE 7: Message_Type value of 0xFF is reserved and shall not be used (used as a stuff byte in the downstream MPEG2 packet).

Table 39: MAC message structure

MAC_message(){	Bits	Bytes	Bit Number/Description
Message_Length	16	2	In DS messages only.
Message_Configuration		1	
Reserved	2		7..6
Protocol_Version	3		5..3
Syntax_Indicator	3		2..0
Message_Type	8	1	
If (Syntax_Indicator == 01 Syntax_Indicator == 10) {			
MAC_Address	(48)	(6)	
}			
If (Syntax_Indicator == 10) {			
Fragment_Count	(8)	(1)	
}			
MAC_Information_Elements ()		N	
CRC	8	1	In DS messages only.
}			

Message_Length

Message_Length indicates the length of the MAC message. The length shall not exceed 0xFEFF.

The message length field is present only in downstream messages.

Protocol Version

Protocol_Version is a three-bit field used to identify the current MAC version. The value for this parameter is given in table 40.

Table 40: Protocol_Version coding

Value	Definition
0	DVB-RCT v1.0 compliant device
1-7	Reserved

Syntax Indicator

Syntax_Indicator is a two-bit enumerated type that indicates the addressing type contained in the MAC message.

```
Enum Syntax_Indicator
{No_MAC_Address, MAC_Address_Included, Fragment_Message,
reserved};
```

MAC Address

MAC_Address is a 48-bit value representing the unique MAC address of the NIU. This MAC address may be hard coded in the NIU or be provided by external source.

Fragment_Count

Identification of a fragment in a MAC message transmitted in multiple fragments. A MAC Message divided into N fragments, is transmitted with Fragment_Count = N, N-1, ... 1.

MAC Information Elements

MAC_Information_Elements is a multiple byte field that contains the body of one and only one MAC message.

CRC_8

CRC_8 is an unsigned 8-bit integer representing an 8-bits CRC with $X^8 + X^7 + X^6 + X^4 + X^2 + 1$ as polynomial sequence. The CRC is computed on the complete MAC message. The CRC field is present only in downstream messages.

8.4.2 MAC Initialization and Provisioning

This clause defines the procedure for Initialization and Provisioning that the MAC performs during power on or Reset.

- 1) Once an NIU becoming active (i.e. powered up), it shall first find the current provisioning channel. The NIU receives the **<MAC> Provisioning Channel Message**. This message is sent periodically (at least one in 900 ms) on all downstream channels carrying MAC information when there are multiple channels. In the case of only a single channel, the message indicates the current channel is to be utilized for Provisioning. Upon receiving this message, the NIU tunes to the DS Provisioning Channel.
- 2) After a valid lock indication on a Provisioning Channel, the NIU waits for the **<MAC> Default Configuration Message**. When received, the NIU configures its parameters as defined in the default configuration message. The Default Configuration Parameters include default timer values, default physical characteristics, default retry counts as well as other information related to the operation of the MAC protocol.

If several DS channels exist, the **<MAC> Default Configuration Message** is sent periodically by the INA for all US channels currently active in the cell. This message is broadcast on all of the DS channels in the cell.

Figure 44 shows the signalling sequence.

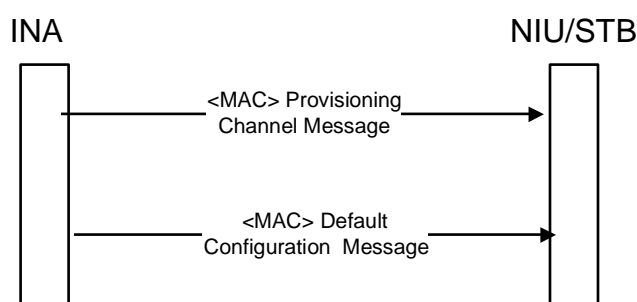

Figure 44: Initialization and Provisioning signalling

8.4.2.1 <MAC> Provisioning Channel Message (Broadcast Downstream)

The **<MAC> Provisioning Channel Message** is sent by the INA to direct the NIU to the proper channel where provisioning is performed. The format of the message is shown in table 41.

Table 41: Provisioning Channel Message Structure

Provisioning_Channel_Message(){	Bits	Bytes	Bit Number/Description
Total_Number_of_US_Channels	8	1	
Provisioning_Channel_Control_Field	8	1	
Reserved	7		7-1
Provisioning_Channel_Included	1		0: {no=0, yes=1}
if (Provisioning_Channel_Included) {			
Provisioning_Channel	(32)	(4)	
}			
}			

Total_Number_of_US_Channels

This 8-bit unsigned integer gives the total number of upstream channels at the transmitter site to allow the RCTT to count the total number of different configuration messages to receive before trying the sign-on procedure.

Provisioning_Channel_Control_Field

Provisioning_Channel_Control_Field is used to specify which parameters are included in the message.

Provisioning_Channel_Included

Provisioning_Channel_Included is a Boolean, that when set, indicates that a downstream channel is specified that the NIU shall tune to in order to begin the provisioning process. When cleared, indicates that the current downstream channel is the provisioning channel.

Provisioning_Channel

Provisioning_Channel is a 32-bit unsigned integer representing the DS Channel in which NIU provisioning occurs. The unit of measure is Hertz (Hz).

8.4.2.2 <MAC> Default Configuration Message (Broadcast Downstream)

The <MAC> Default Configuration Message is sent by the INA to the NIU. The message provides default parameter and configuration information to the NIU.

The <MAC> Default Configuration Message corresponds to one upstream channel. Several upstream channels could coexist at one transmitter site (e.g. sectorization) to minimize interference, or to cope with increasing capacity demands. Several <MAC> Default Configuration Messages are sent cyclically, describing each return channel in the cell. US_Channel_Id identifies each upstream channel.

Each of the cells can contain several upstream channels; one of the available channels is used by RCTTs as a service channel to the cell, which means that this channel is used to enter the network via the ranging and sign-on procedure. The INA broadcasts the parameters of the service channel as the Upstream_Channel_Frequency in the <MAC>Default Configuration Message; the INA can change the service channel due to congestion or load-balancing reasons.

The format of the message is shown in table 42.

Table 42: Default configuration message structure

Default_Configuration_Message(){	Bits	Bytes	Bit Number/Description
US_Channel_identifier	8	1	
Sign_On_Incr_Pwr_Retry_Count	8	1	
Upstream_Channel_Frequency	32	4	
Max_Number_Time_Slot	16	2	
Max_Power_Level	8	1	
Min_Power_Level	8	1	
Time_Stamp_Identifier	8	1	
Delay_max	24	3	
Synchronization_field_rate	8	1	
Reservation_Offset	8	1	
Upstream_Channel_Key	8	1	

Default_Configuration_Message(){	Bits	Bytes	Bit Number/Description
Upstream_Control_Field		3	
Reserved	8		23..16
Freq_Hopping	1		15
Quick_Sign_On	1		14
Coding	2		13..12
Shaping	1		11
FFT_Size	1		10
Mode	2		9..8
Guard_Interval	2		7..6
Modulation	2		5..4
Code_Rate	2		3..2
Medium_Access	2		1..0
Max_Backoff_Exponent	8	1	
Min_Backoff_Exponent	8	1	
Idle_Interval	16	2	
Ranging_Control_Field	16	2	
Ranging_Interval_Size	4		15..12
Short_Ranging	12		11..0
Number_of_Timeouts	8	1	
<i>for (I=0; I<Number_of_Timeouts; I++) {</i>			
Timer_Field		(1)	
Code	(4)		
Value	(4)		
<i>}</i>			
INA_Capabilities		3	
Encapsulation	8		23..16
Reserved	8		15..8
Piggy_Back_Capable	1		7: {no,yes}
Resource_Request_Capable	1		6: {no,yes}
Fragmented_MAC_Messages	1		5: {no,yes}
Security_Supported	1		4: {no,yes}
Ranging_Bandwidth_Request	1		3: {no,yes}
Reserved	3		2..0
<i>if (Medium_Access == 10 Medium_Access == 11) {</i>			
Upstream_Channel_Start	(8)	(1)	
Upstream_Channel_End	(8)	(1)	
<i>}</i>			
<i>}</i>			

US_Channel_Identifier

Identification number of the upstream channel: if the most significant bit of this field is set then the US channel is a "service" channel.

Sign-On Increment Power Retry Count

Sign_On_Incr_Pwr_Retry_Count is an 8-bit unsigned integer representing the number of attempts the NIU shall try to enter the system at the same power level before incrementing its power level in steps of 6 dB.

Upstream Channel Frequency

Upstream_Channel_Frequency is a 32-bit unsigned integer representing the upstream frequency assigned to the upstream service channel. The unit of measure is in Hertz (Hz).

Max_Number_Time_Slot

Max_Number_Time_Slot is a 16 bit unsigned integer representing the largest slot value of the NIU's upstream slot position counter.

Maximum Power Level

Max_Power_Level is an 8-bit unsigned integer representing the maximum power that the NIU is allowed to use to transmit upstream. The unit of measure is in dBm. A value of zero represents -50 dBm. Each increment of this value is in steps of 1 dBm.

Minimum Power Level

Min_Power_Level is an 8-bit unsigned integer representing the minimum power that the NIU is allowed to use to transmit upstream. The unit of measure is in dBm. A value of zero represents -50 dBm. Each increment of this value is in steps of 1 dBm.

Time_Stamp_Identifier

Time_stamp_identifier is an 8-bit unsigned integer representing the identifier of the synchronization field to be used with the current upstream channel. Several upstream channels with same physical parameters can have same Time_Stamp_Identifier value.

Delay_max

Delay_max is an unsigned 24-bit integer representing the maximum value of processing for a demodulator in the network. This field is expressed as a number of the DVB-T clock cycles (64/7 MHz or 56/7 MHz or 48/7 MHz) and take into account the longest delay needed to demodulate the forward COFDM signal in the slowest RCTT in the network.

Synchronization_field_rate

Synchronization_field_rate is an enumerated value representing the insertion rate of the synchronization field in the Downstream transport stream (see clause 6.4), possible values for this field are: {16 Hz, 64 Hz, 256 Hz, reserved}.

Reservation_Offset

Reservation_Offset is an 8-bit unsigned number used to interpret the <MAC>Slot State Message as defined in clause 8.4.3.4.

Upstream_Channel_Key

Upstream_Channel_Key denotes the upstream channel, up to the 59 (2K) or 29 (1K) different sets of permutations that can be achieved. This parameter is relevant for TF2 only.

Upstream Control Field

Gives the default physical characteristics of the upstream physical channel:

- **Freq_Hopping:** is a Boolean field indicating that the RCTTs shall access the channel using Frequency Hopping technique;
- **Quick_Sign_on:** is a Boolean field indicating that the RCTT is allowed to start the ranging process with value of power level that it has used for its last upstream transmission after a successful calibration process. If the bit is not set, the RCTT has to enter the ranging process starting with the Min_Power_Level value. This bit is only to be taken into account for ranging processes that follow the reception of a **Transmission Control Message, Reprovision_Message or Connect_Message**. In all other cases the value of **Min_Power_Level** have to be used independent of the setting of the **Quick_Sign_On** bit;
- **Coding:** Defines the coding scheme: 0 = Reed Solomon; 1= Turbo Code; other 2 values reserved;
- **Shaping:** Defines the pulse shaping, 0 = Nyquist; 1 = Rectangular;
- **FFT_Size:** Defines the system FFT size: 0 = 1K; 1 = 2K;
- **Mode:** Defines the working symbol rate, Values 0 to 2 means Carrier Spacing CS1 to CS3;
- **Guard_Interval:** 0 = 1/4; 1 = 1/8; 2 = 1/16; 3 = 1/32;
- **Modulation:** 1 = QPSK; 2 = 16QAM; 3 = 64QAM;

- **Code_Rate:** 0,4 = Reserved; 1 = 1/2; 2 = 3/4;
- **Medium_Access:** 0 = MAS1; 1 = MAS2; 2 = MAS3-BS2, 3 = MAS3-BS3.

Min_Backoff_Exponent

Min_Backoff_Exponent is an 8-bit unsigned integer representing the minimum value of the backoff exponent counter in number of time slots. Only the 5 least significant bits are valid, the 3 most significant bits are reserved for future use.

Max_Backoff_Exponent

Max_Backoff_Exponent is an 8-bit unsigned integer representing the maximum value of the backoff exponent counter in number of time slots. Only the 5 least significant bits are valid, the 3 most significant bits are reserved for future use.

Idle_Interval

Idle_Interval is a 16-bit unsigned integer representing the predefined interval for the Idle Messages. Valid intervals are between 60 and 600, where the unit of the measure is in seconds. In addition, the value of zero indicates that no idle messages are sent.

Ranging_Control_Field

Short_Ranging is a 12-bit unsigned integer representing the short ranging sub-channel(s), this field has two uses according to the selected access scheme (MAS 1, 2 or 3).

- For **MAS1** and **MAS2** the Short_Ranging field represents the short ranging sub-channels in the ranging time slot, possible values are 0..4 095 for 2K mode and 0..63 for 1K mode, the sub-channels are determined from the binary representation of the integer value;
- For **MAS3** the Short_Ranging field represent the ranging sub-channel from all the Ranging sub-channels, possible values are: 0..11 for 2K mode and 0..5 for 1K mode, the value represent the sub-channel number reserved for ranging access.

When working in MAS1 or MAS2 in 2K carriers mode, for each ranging symbol there are 12 possible ranging sub-channels for each ranging time symbol.

The Short Ranging field will define which of the sub-channels shall be used for short ranging purposes.

If, for example, sub-channels 0, 2, 3, 8 and 10 (when enumerated from 0-11) should be used for short ranging and all others should be used for long ranging, the bitmap representing the short ranging sub-channels would be:

010100001101, the Short_Ranging field will have the decimal value of the bitmap, meaning:

$2^0 + 2^2 + 2^3 + 2^8 + 2^{10} = 1\ 293$ which will be equivalent to the bitmap.

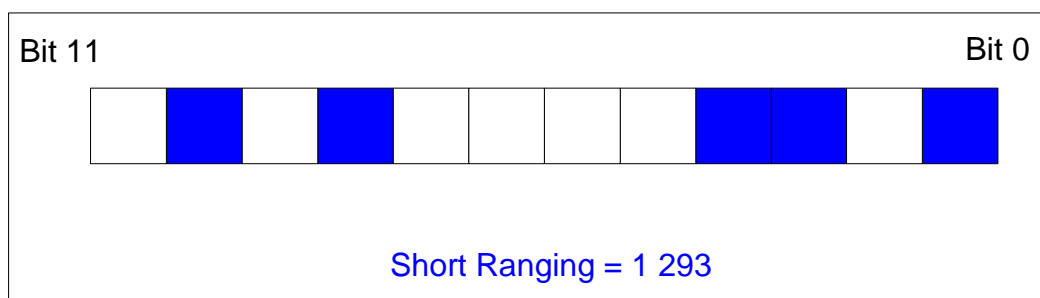

Figure 45: Example of Short/Long ranging sub-channel mapping for MAS1 or MAS2 in 2K mode

For 1K mode, only 6 ranging sub-channels exist for each ranging time symbol, for this case, a bitmap of 6 bits is needed to represent the sub-channels. For the 1K mode, the possible values for the Short_Ranging field are 0..63, the mapping of the sub-channels is done as in the 2K mode.

When working in MAS3, there are 12 (6) possible Ranging sub-channels for each time symbol in 2K (1K) carriers mode, one of the sub-channels is used as a ranging sub-channel, all other carriers will be used for data sub-channels.

The Short-Ranging field, in this case, will indicate which one on the Ranging sub-channels will be used to perform ranging, meaning that if Short_Ranging = 3 then the Ranging sub-channel number 3 shall be used for ranging and all the other carriers will be allocated for "data" sub-channels.

Ranging_Interval_Size is a 4-bit integer representing the number of ranging time slots for MAS1 and MAS2. The allocation is in multiples of 6 time slots.

Number_of_Timeouts is an 8-bit unsigned integer that identifies the number of timeout codes and values included in the message.

Code: Code is a 4-bit unsigned integer, which identifies the timeout or group of timeouts (according to table 43, table 44 and table 76 for which the following values are given).

Value is a 4-bit unsigned integer that gives the value for the timeout or group of timeouts identified by the preceding code. The timeout can be derived from the following table.

Value	Timeout (ms) (see note)
0	Infinite (disabled)
1	9
2	30
3	60
4	90
5	300
6	600
7	900
8	3 000
9	6 000
10	9 000
11	30 000
12	60 000
13	Reserved
14	Reserved
15	Reserved
NOTE: In some cases, a time relative to the Time_Slot duration shall be added to these timeout values (see default timeouts tables and Time_Slot duration table).	

If no values are given in the <MAC> **Default Configuration Message**, the default values apply.

Table 43: Headend Timeout Values

Code	Transaction(s)	Default Value (ms)
0x0	Ranging and power calibration -> Ranging Code Ranging and power calibration -> Sign On Response Connect -> Connect response (no upstream channel change) Release -> Release response Transmission control -> Link management response (no upstream channel change) Reservation ID assignment -> Reservation ID response Reprovision -> Link management response (no upstream channel change) Status request -> Status response message Init complete -> Connect response Init. complete -> Link management response	$2 \times \text{Time_Slot_duration} + 300$
0x1	Connect -> Ranging code (only for upstream channel change) Reprovision -> Ranging code (only for upstream channel change) Transmission control -> Ranging code (only for upstream channel change)	$2 \times \text{Time_Slot_duration} + 3\ 000$

The Unit for the timeouts is ms.

These timeouts apply when the mentioned two messages are consecutive.

Time_Slot duration is a value to be added in physical configurations where the upstream transmission is not negligible (see table "Time Slot duration values").

Table 44: Terminal Timeout Values

Code	Transaction(s)	Default Value (ms)
0x2	Default configuration interval (time between two Def. Conf. message) Provisioning channel interval	900
0x3	Ranging code -> Ranging and power calibration Sign on-> Initialization complete Connect response -> Connect confirm Resource Request -> Release Resource Request -> Reservation_ID assignment	2 × Time_Slot_duration + 90
0x4	Initialization complete -> Connect Timeout in ERROR state (time to wait before going to "Wait for Provisioning Message" state, see clause 8.4.3.1)	300
0x4	Resource Request -> Resource Request Denied Resource Request -> Connect Resource Request -> Reprovision	2 × Time_Slot_duration + 300

The Unit for the timeouts is millisecond.

These timeouts apply when the mentioned two messages are consecutive.

Time_Slot duration is a value to be added in physical configurations where the upstream transmission is not negligible (see table 45).

Timeouts are assumed to be set prior to transmission.

Table 45: Approximate Time Slot Maximum Duration Values (ms)

	CS1	CS2	CS3
BS1	250	125	60
BS2	90	45	25
BS3	Negligible		

INA_Capabilities

INA_Capabilities is a 24-bit field that indicates the capabilities of the INA. It has the following sub fields:

- **Encapsulation** is an 8-bit field that indicates the type(s) of encapsulation supported by the INA: {DIRECT_IP, Ethernet_MAC_Bridging, PPP, Low_Latency_Telephony, reserved 4..7}. Bit 0 is the lsb and corresponds to bit 24 of the INA_Capabilities field;
- **Reserved:** Reserved for future use;
- **Piggy_Back_Capable** is a 1-bit field that indicates if the INA is able to process Piggy Back requests and assignments;
- **Resource_Request_Capable** is a 1-bit field that indicates if the INA is able to process <MAC> **Resource Request Messages**;
- **Fragmented_MAC_Messages** is a 1-bit field that indicates that the INA is able to support MAC messages having the compound MAC_Information_Elements field of a single up to 512 bytes in size. This flag is also for backwards compatibility with INAs not supporting MAC message fragmentation and re-assembly. By not setting this bit, the INA indicates that it does not support fragmented MAC messages at all, and does not understand or utilize the **Fragment_Message** MAC message syntax types;

- **Security_Supported** is a 1-bit field that indicates that the INA is able to support the security extensions specified in this protocol;
- **Ranging_Bandwidth_Request** is a 1-bit field that indicates that the INA supports bandwidth requests using the Ranging time slots (see clause 8.4.7).

Upstream-Channel Start:

- **Upstream channel start** is an 8-bit unsigned integer containing a BS3 sub-channel number. This number indicates the first used data sub-channel number in the upstream channel.

Upstream-Channel End:

- **Upstream channel end** is an 8-bit unsigned integer containing a BS3 sub-channel number. This number indicates the last used data sub-channel number in the upstream channel.

8.4.3 Sign On and Calibration

The NIU signs on via the Ranging and Sign-On Procedures. The signalling flow for the process is described below.

The NIU tunes to the downstream Provisioning channel and the upstream channel with the information provided in the Initialization and Provisioning sequence.

The RCTT performs the ranging process to get synchronized in power and time.

The RCTT selects randomly an initialization ranging code and sends this code on the ranging slot in MAS 3 or on randomly selected ranging slot in MAS 1 and MAS 2. According to the **Quick_Sign_On** flag of the **<MAC> Default Configuration Message**, the RCTT uses the last known parameters or starts with **Min_Power_Level** setting.

If the RCTT does not receive any response message from the INA when using quick sign-on, the RCTT starts from the **Min_Power_Level** setting.

The INA receives the ranging code, learns all the power, channel behaviour (for adaptive modulation) and synchronization corrections that are needed to be done and sends a **<MAC> Ranging and Power Calibration Message** which contains the needed adjustments.

Within the **<MAC> Ranging and Power Calibration Message**, the INA also sends the time slot number and the selected code, which is used by the RCTT to identify the message as its ranging response.

The synchronization process shall be repeated until the response contains a successful or aborting notification.

The INA sends the **<MAC> Ranging and Power Calibration Message** with a successful status when the RCTT is calibrated.

At the successful initialization notification, the INA can allocate upstream slot for the RCTT to continue the sign-on process in reserved mode, if no allocation is done, the sign-on process shall continue in contention slots.

When The RCTT has been synchronized with the INA, the RCTT can start the sign-on process by sending the **<MAC>Sign-On Message**.

The INA, upon receiving the Sign-On Message validates the NIU and sends the **<MAC> Initialization Complete Message**.

If the **<MAC> Sign-On Message** is not acknowledged, the RCTT tries several times at the same power, and then tries another service channel. If no answer is received from all the channels available, then the RCTT increases the power level and tries again.

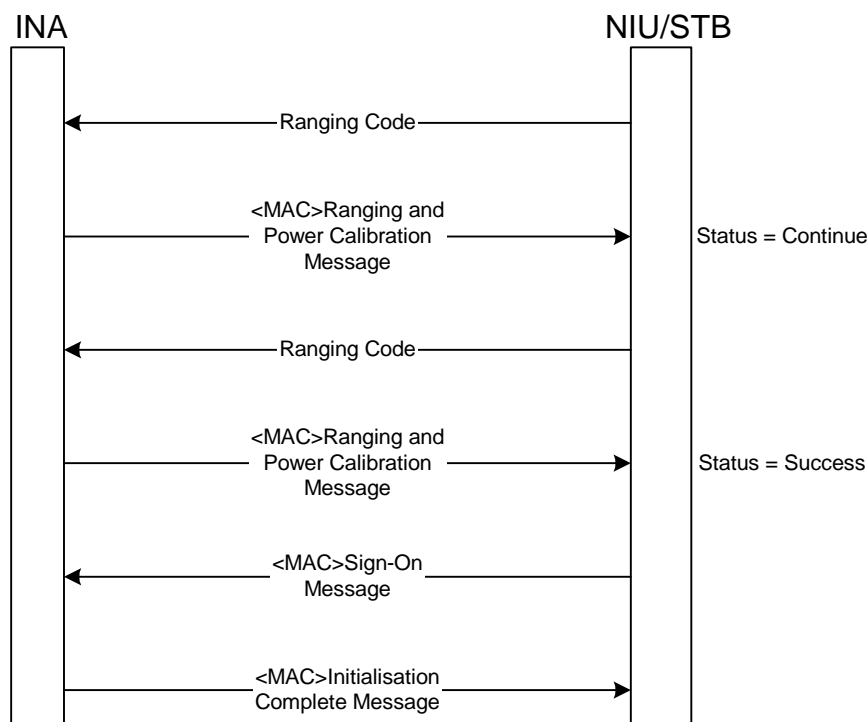

Figure 46: Ranging and Calibration Signalling

A more detailed description of the ranging and calibration process, including state diagrams and time outs, is given in annex E.

8.4.3.1 <MAC> Ranging and Power Calibration Message (Broadcast/Singlecast Downstream)

The <MAC> **Ranging and Power Calibration Message** is sent by the INA to the NIU to adjust the power level, frequency value or time offset the NIU is using for upstream transmission. The format of this message is shown in table 46.

The receipt of the <MAC>**Ranging and Power Calibration Message** is stateless from the RCTT point of view.

Table 46: Ranging and Power Calibration Message structure

Ranging_and_Power_Calibration_Message(){	Bits	Bytes	Bit Number/Description
Number_of_Elements	8	1	
<i>For (I=0; I<Number_of_Elements; I++) {</i>			
Range_Power_Control_Field		1	
Reserved	2		7..6
BandWidth_Allocation_Included	1		5: {no, yes}
Ranging_Id_Included	1		4: {no, yes}
Reserved	1		3
Frequency_Adjustment_Included	1		2: {no, yes}
Time_Adjustment_Included	1		1: {no, yes}
Power_Adjustment_Included	1		0: {no, yes}
Status_Field		1	
<i>if (Range_Power_Control_Field and=</i> <i>Ranging_Id_Included) {</i>			
Ranging_Id		(5)	
<i>Time_Slot_Number</i>	(16)	(2)	
<i>Ranging_Code</i>	(8)	(1)	
<i>Ranging_Sub_Channel_Number</i>	(8)	(1)	
<i>Time_Symbol_Number</i>	8	(1)	
<i>}</i>			

Ranging_and_Power_Calibration_Message(){	Bits	Bytes	Bit Number/Description
<i>if (Range_Power_Control_Field and=</i> <i>Time_Adjustment_Included) {</i>			
Time_Offset_Value	(16)	(2)	
<i>}</i>			
<i>if (Range_Power_Control_Field and=</i> <i>Power_Adjustment_Included) {</i>			
Power_Control_Setting	(8)	(1)	
<i>}</i>			
<i>if (Range_Power_Control_Field and=</i> <i>Frequency_Adjustment_Included) {</i>			
Frequency_Adjustment	(8)	(1)	
<i>}</i>			
<i>If (Status_Field == 1) andand</i> <i>(BandWidth_Allocation_Included == 1) {</i>			
Grant_Slot		(4)	
Time_Slot_Number	16	(2)	
Sub-Channel_Number	16	(2)	
<i>}</i>			
<i>}</i>			

Number_of_Elements

Number_of_Elements is an 8-bit unsigned integer that indicates the number of calibration information elements is included in the Ranging_and_Power_Calibration Message.

Range and Power Control Field

Range_Power_Control_Field specifies which Range and Power Control Parameters are included in the message.

BandWidth_Allocation_Included

BandWidth_Allocation_Included is a Boolean, that when set, indicates that Grant_Slot field is included in the message.

Ranging_Id_Included

Ranging_Id_Included is a Boolean, that when set, indicates the value of the received Ranging_Id.

Frequency_Adjustment_Included

Frequency_Adjustment_Included is a Boolean field, when set, it indicates that frequency adjustment value is included in the message.

Time_Adjustment_Included

Time_Adjustment_Included is a Boolean, that when set, indicates that a relative Time Offset Value is included that the NIU shall use to adjust its upstream slot transmit position.

Power_Adjustment_Included

Power_Adjustment_Included is a Boolean, that when set, indicates that a relative Power Control Setting is included in the message.

Status_Field

Status_Field defines the status of the ranging process, possible values are:

- 1) **Success** - The RCTT is calibrated with the INA;
- 2) **Continue** - The ranging process has not finished yet, the RCTT shall continue with the process;
- 3) **Power Synchronization error** - Error with power synchronization, RCTT shall abort;
- 4) **Timing Synchronization error** - Error with time synchronization, RCTT shall abort;
- 5) **Other error** - Undefined error during the ranging process, RCTT shall abort.

Ranging_Id

Ranging_Id defines the received ranging parameters from the NIU. The <MAC> **Ranging and Power Calibration Message** is addressed to a specific NIU using this field.

Time_Slot_Number is a numerical value that represents the time slot index in which the ranging code was sent.

Time_Symbol_Number is a numerical value that represents the first time symbol in which the ranging code was sent, among the time-symbols of the ranging slot.

Ranging_Code The Ranging_Code field represents the ranging code that was sent by the INA to the NIU/RCTT.

Ranging_Sub_Channel_Number: Ranging_Sub_Channel_Number represents the ranging/synchronization sub channel used by the NIU/RCTT, in MAS1 and MAS2 this field can have the values between 0..11 in 2K mode and 0..5 in 1K mode, in MAS3 this field will have the number of the sub-channel that was assigned to ranging in the <MAC>**Default Configuration Message**.

Frequency_Adjustment is an 8-bit signed integer that is used to specify an approximate frequency correction to the RCTT(units in Hz). A positive number means an increase in frequency.

Time_Offset_Value is a 16-bit short integer representing a relative offset of the upstream transmission timing. A negative value indicates an adjustment forward in time (later). A positive value indicates an adjustment back in time (earlier). The unit of measure is the DVB-T clock period. (The NIU approximately adjusts its time offset to the closest value indicated by the Time_Offset_Value parameter, which implies that no extra clock is needed to adjust to the correct offset).

Power Control Setting

Power_Control_Setting is an 8-bit signed integer that is used to set the new power level of the NIU. (A positive value represents an increase of the output power level measured in steps of 1 dB).

$\text{New output_power_level} = \text{current output_power_level} + \text{power_control_setting}$.

Grant_Slot

Time_Slot_Number is the 16 bit unsigned integer representing the number of a time slot.

Sub_Channel_Number is a 16 bit unsigned integer giving the index of the sub-channel to use.

8.4.3.2 <MAC> Sign-On Message (Singlecast Upstream)

The <MAC> **Sign-On Message** is sent by the NIU to start the initialization procedure.

Table 47: Sign-On Message structure

Sign-On_Message(){	Bits	Bytes	Bit Number/Description
US_Channel_identifier	8	1	
NIU/RCTT_Status		1	
Reserved	5		7..3
Network_Address_Registered	1		2: {no, yes}
Connection_Established	1		1: {no, yes}
Reserved for compatibility	1		0
NIU/RCTT_Error_Code		1	
Reserved	5		7..3
Connect_Confirm_Timeout	1		2: {no, yes}
First_Connection_Timeout	1		1: {no, yes}
Range_Response_Timeout	1		0: {no, yes}
NIU/RCTT_Retry_Count	8	1	
NIU/RCTT_Capabilities		3	
Encapsulation	8		23..16
Reserved	8		15..8
Piggy_Back_Capable	1		7: {no, yes}
Resource_Request_Capable	1		6: {no, yes}
Fragmented_MAC_Messages	1		5: {no, yes}
Security_Supported	1		4: {no, yes}
BS2_in_MAS3_Supported	1		3: {no, yes}
Reserved	3		2..0:
Power_Control_Setting	8	1	
}			

NIU/RCTT_Status

NIU/RCTT_Status is an 8-bit field that indicates the current state of the NIU/RCTT.

It has the following sub fields:

- **Network_Address_Registered** indicates that the Network Interface Module has registered its NSAP Address with the Application Module. The NSAP Address is not currently used but remains reserved for this purpose;
- **Connection_Established** indicates that the Network Interface Module has been assigned Connection parameters.

NIU/RCTT_Error_Code

NIU/RCTT_Error_Code is a 16-bit field that indicates the error condition within the NIU/RCTT. It has the following sub fields:

- **Connect_Confirm_Timeout** (see annex E);
- **First_Connection_Timeout** (see annex E);
- **Range_Response_Timeout** (see annex E).

In case of a timeout in the current signalling, the corresponding sub field is set to one, see annex E.

NIU/RCTT_Retry_Count

NIU/RCTT_Retry_Count is an 8-bit unsigned integer that indicates the number of transmissions of the <MAC> **Sign-On Message**. This field shall be initialized to zero whenever a Sign-On procedure is started, and this field shall be incremented by one each time the message is transmitted until the Sign-On procedure completes or the value reaches its maximum value (255). In the case that this field reaches its maximum value, it shall remain at the maximum value for the remainder of the current Sign-On procedure. This parameter is used by the INA for statistical purposes to determine the number of attempts to sign-on.

NIU/RCTT_Capabilities

NIU/RCTT_Capabilities is a 24-bit field that indicates the capabilities of the NIU/RCTT.

It has the following sub fields:

- **Encapsulation** is an 8-bit field that indicates the type(s) of encapsulation supported by the NIU/RCTT: {DIRECT_IP, Ethernet_MAC_Bridging, PPP, Low_Latency_Telephony, reserved 4..7}. Bit 0 is the lsb and corresponds to bit 24 of the NIU/RCTT_Capabilities field;
- **Reserved:** Reserved for future use;
- **Piggy_Back_Capable** is a 1-bit field that indicates if the NIU is able to append Piggy Back requests onto a PDU data cells;
- **Resource_Request_Capable** is a 1-bit field that indicates if the NIU is able to send <MAC> **Resource Request Messages**;
- **Fragmented_MAC_Messages** is a 1-bit field that indicates that the NIU/RCTT is able to support MAC messages having the compound MAC_Information_Elements field of a single up to 512 bytes in size. This flag is also for backwards compatibility with NIU/RCTTs not supporting MAC message fragmentation and re-assembly. By not setting this bit, the NIU/RCTT indicates that it does not support fragmented MAC messages at all, and does not understand or utilize the Fragment_No_MAC_Address and Fragment_MAC_Address_Included MAC message syntax types;
- **Security_Supported** is a 1-bit field that indicates that the NIU/RCTT is able to support the security extensions specified in this protocol;
- **BS2_In_MAS3_Supported** is a 1-bit field that indicates if the RCTT supports mixing of BS2 and BS3 sub-channels in MAS3. When this bit is set to one, then the RCTT supports full MAS3 functionality, when this bit is set to zero, then the RCTT support only BS3 sub-channels in MAS3 configuration.

Power_Control_Settings

Power_Control_Settings is an 8-bit unsigned integer representing the actual power used by the NIU for upstream transmission. A value of zero represents -50 dBm. Each increment of this value is a step of 1 dBm.

8.4.3.3 <MAC> Initialization Complete Message (Singlecast Downstream)

The <MAC> **Initialization Complete Message** is sent by the INA to the NIU/RCTT to indicate the end of the Sign-On and Provisioning procedure. The RCTT re-enters the initialization process after receiving a non-zero **Completion_Status_Field** value. The <MAC> **Transmission Control Message** can be used to stop the NIU from sending upstream messages.

Table 48: Initialization_Complete_Message structure

Initialization_Complete_Message(){	Bits	Bytes	Bit Number/Description
Completion_Status_Field		1	
Reserved	6		7..2
Invalid_RCTT	1		1: {no, yes}
Other_Error	1		0: {no, yes}
}			

Completion_Status_Field

Completion_Status_Field is an 8-bit field that indicates errors in the initialization phase. It has the following sub fields:

- **Invalid_RCTT** is a Boolean that (when set to 1) indicates that the RCTT is invalid;
- **Other_Error** is a Boolean that (when set to 1) indicates an error with unspecified type.

8.4.3.4 <MAC> Slot State message (Broadcast Downstream)

The **Slot State Message** gives feedback information for possible collisions and slot reservation status of the return channel slots.

One slot state message gives information for one return channel (described in the <MAC> **Default Configuration Message**). There is one slot state message broadcast for each return channel available at one transmitter site. The slot state message is sent at each slot duration and describes:

- any collisions detected in the slot contained in the Collision_Time_Slot_Number;
- the reserved status of a future slot. The number of this future slot is given by the Collision_Time_Slot_Number plus the Reservation_Offset as defined in the <MAC> **Default Configuration Message**.

If the <MAC> Slot_State_Message describes the "reserved status" of the time slot immediately following the one in which it is received, then it shall be received by the RCTT within the first two-thirds of the time slot.

In MAS3, the sub-channels described are the relevant ones for this MAS3 configuration (MAS3-BS2 or MAS3-BS3: cf. Default Configuration Message, fields "Upstream_channel_Start" and "Upstream_Channel_End").

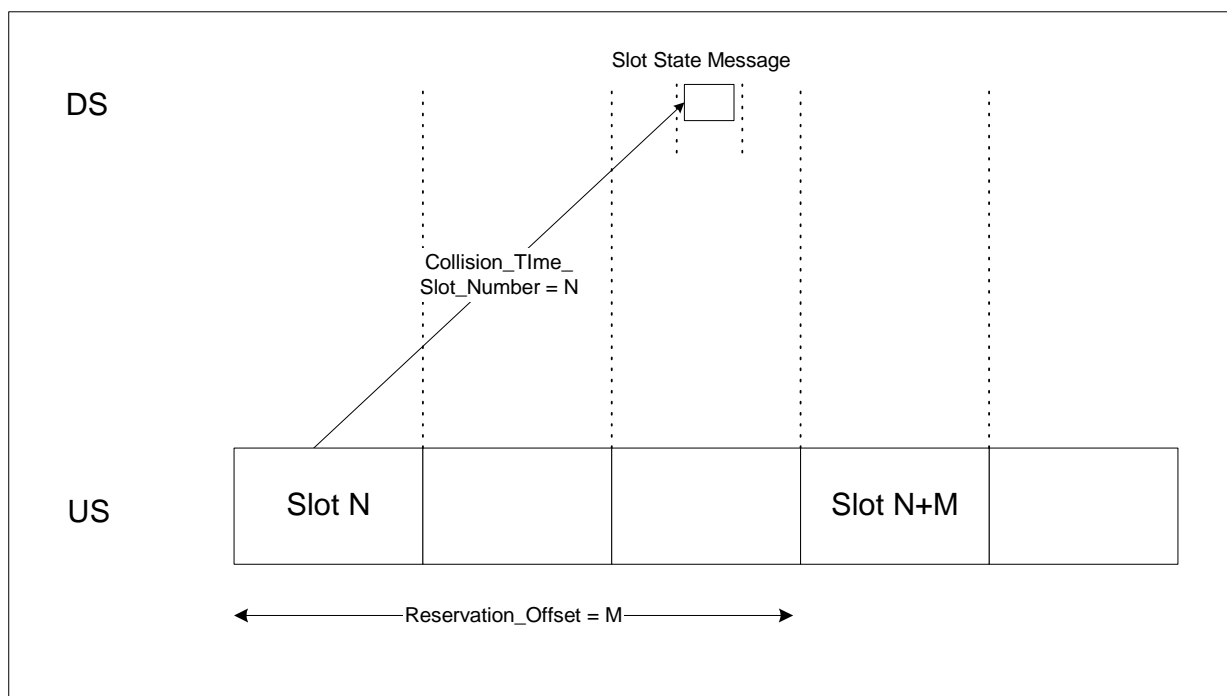
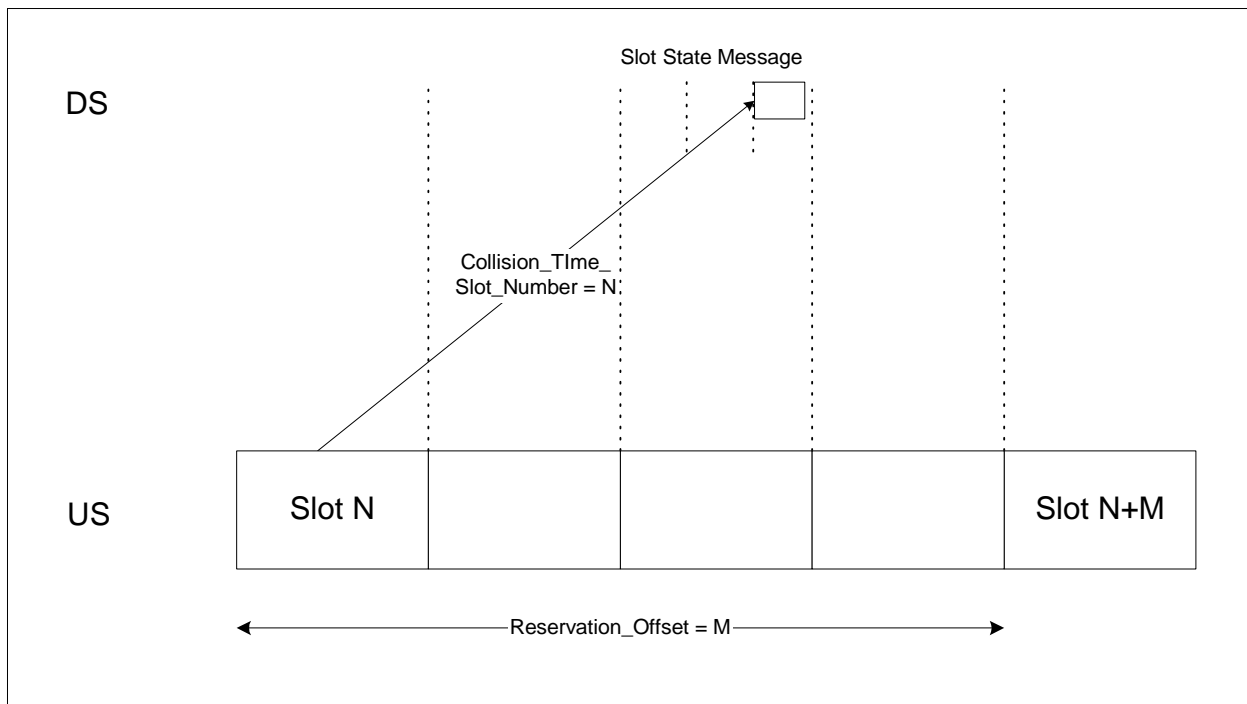

Figure 47: Examples of configurable Slot_State message delay

Table 49: Slot_state_Message structure

Slot_state_Message(){	Bits	Bytes	Bit Number/Description
US_Channel_Identifier	8	1	
Collision_Time_Slot_Number	16	2	
Number_Of_Sub_Channels	16	2	
for (I=0; I<Number_Sub_channels;I++) {		Variable	
Status_Field			
collision	1		
reserved_slot	1		
}			
Padding bits up to next byte	Variable		
}			

US Channel identifier:

The US_Channel_Identifier is a unique channel descriptor equivalent to the channel identifier in the Provisioning Channel Message.

Collision_Time_Slot_Number:

Collision_Time_Slot_Number is the number of the time slot to which the collision applies.

Number_of_sub_channels:

Number_Of_Sub_Channels is the number of sub-channels in the return channel.

Status_Field

- **Collision:** 0=no collision on the Collision_Time_Slot; 1=collision on the Collision_Time_Slot;
- **Reserved_slot:** 0=next relevant slot in contention mode; 1=next relevant slot in reserved mode.

Padding bits are used to align on byte boundary depending on number of sub-channels.

8.4.4 Connection Establishment

Two cases shall be considered:

- Establishment of the first (initial) connection;
- Establishment of additional connections.

8.4.4.1 Establishment of the First (Initial) Connection

After Initialization, Provisioning and Sign On Procedures are complete, the INA assigns an upstream and downstream connection to the NIU. This connection can be assigned on any of the upstream channels. The INA assigns the connection by sending the <MAC> **Connect Message** to the NIU. This message shall contain the upstream connection parameters and downstream frequency on which the connection is to reside.

The NIU, upon receiving the <MAC> **Connect Message** shall tune to the required upstream and downstream channel and send the <MAC> **Connect Response Message** conforming receipt of the message. However, if the US and/or the DS channel contained in the <MAC> **Connect Message** is different than the current US and/or DS channel, the NIU shall tune to the new frequency(ies) and enter the Sign_On procedure, the Connection_established flag being set and the NIU retry count reset. The NIU shall send the <MAC> **Connect Response Message** after the <MAC> **Initialization_Complete_Message**.

Upon receipt of the <MAC> **Connect Response Message**, the INA confirms the new connection by sending the <MAC> **Connect Confirm Message**.

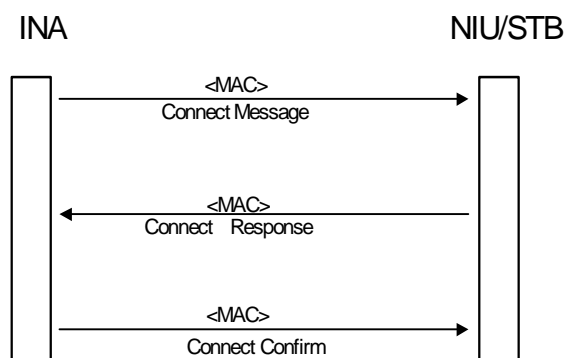

Figure 48: Connection Signalling for the Initial Connection

A more detailed description of the connection establishment process, including state diagrams and time outs, is given in annex E.

8.4.4.2 <MAC> Connect Message (Singlecast Downstream)

Table 50: Connect Message Structure

Connect_Message ()	Bits	Bytes	Bit Number/Description
Connection_ID	32	4	
Session_Number	32	4	
Connection_Control_Field_Aux		1	
Reserved	5		7..3: shall be 0
Session_Binding_Included	1		2: {no, yes}
Encapsulation_Included	1		1: {no, yes}
DS_Multiprotocol_CBD_Included	1		0: {no, yes}
Resource_Number	8	1	
Connection_Control_Field		1	
Reserved	1		7: 0
DS_MPEG_CBD_Included	1		6: {no, yes}
US_ATM_CBD_Included	1		5: {no, yes}
Reserved	3		4..2: 0
Slot_List_Included	1		1: {no, yes}
Cyclic_Assignment	1		0: {no, yes}
Maximum_Contention_Access_Message_Length	8	1	
Maximum_Reservation_Access_Message_Length	8	1	
if (Connection_Control_Field and= DS_MPEG_CBD_Included) {			
Downstream_MPEG_CBD()	(48)	(6)	
}			
if (Connection_Control_Field and= US_ATM_CBD_Included) {			
Upstream_ATM_CBD()	(64)	(8)	
}			
if (Connection_Control_Field and= Slot_List_Included) {			
Number_Slots_Defined	(8)	(1)	
for (i=0; i<Number_Slots_Defined; i++){			
Slot_Pattern	(16)	(2)	
}			
}			
if (MAC_Control_Params == Cyclic_Assignment){			Fixed Rate Access
Fixedrate_Start_Pattern	(64)	(8)	
Fixedrate_Distance	(16)	(2)	
Fixed_Rate_End_Slot_Number	(16)	(2)	
}			
if (Connection_Control_Field_Aux and= DS_Multiprotocol_CBD_Included) {			
Downstream_Multiprotocol_CBD()	(48)	(6)	
}			

Connect_Message (){	Bits	Bytes	Bit Number/Description
<i>if (Connection_Control_Field_Aux and= Encapsulation_Included) {</i>			
Encapsulation	(8)	(1)	
<i>if (Connection_Control_Field_Aux and= Session_Binding_Included {</i>			
<i>if (Encapsulation and= Low_Latency_Telephony) {</i>			
User_Port_ID	(16)	(2)	
<i>}</i>			
<i>if (Encapsulation and= Direct_IP or Encapsulation and= Ethernet_MAC_Bridging) {</i>			
Source_IP_address	(32)	(4)	
Source_port_number	(16)	(2)	
Destination_IP_address	(32)	(4)	
Destination_port_number	(16)	(2)	
<i>}</i>			
<i>if (Encapsulation and= Ethernet_MAC_Bridging) {</i>			
Source_Ethernet_MAC_address	(48)	(6)	
Destin_Ethernet_MAC_address	(48)	(6)	
<i>}</i>			
<i>}</i>			
<i>}</i>			
<i>}</i>			

Connection ID:

Connection_ID is a 32-bit unsigned integer representing a connection Identifier for the NIU Dynamic Connection.

Session Number:

Session_Number is a 32-bit unsigned integer representing the Session that the connection parameters are associated. This parameter is not used by the present document.

Connection Control Field_Aux:

- **Reserved** is a 5-bit field, for future extensions. This field shall be zero;
- **Session_Binding_Included** is a Boolean that indicates that the session binding parameters (e.g. IP addresses and port numbers) are included in the message;
- **Encapsulation_Included** is a Boolean that indicates that the type of encapsulation is included in the message;
- **DS_Multiprotocol_CBD_Included** is a Boolean that indicates that the Downstream Multiprotocol Descriptor is included in the message.

Resource Number:

Resource_Number is an 8-bit unsigned integer providing a unique number to the resource defined in the message. If the Connect Message is the result of a Resource Request by the NIU, it shall be equal to the Resource_Request_ID of the Resource Request otherwise it shall be 0.

Connection Control Field:

- **DS_MPEG_CBD_Included** is a Boolean that indicates that the Downstream Descriptor is included in the message;
- **US_ATM_CBD_Included** is a Boolean that indicates that the Upstream Descriptor is included in the message;
- **Slot_List_Included** is a Boolean that indicates that the Slot List is included in the message. Having Cyclic Assignments and Slot List Assignments for the same **Connection_ID** at the same time is not allowed;

- **Cyclic_Assignment** is a Boolean that indicates Cyclic Assignment. Having Cyclic Assignments and Slot List Assignments for the same **Connection_ID** at the same time is not allowed.

Maximum Contention Access Message Length:

Maximum_Contention_Access_Message_Length is an 8-bit number representing the maximum length of a message in upstream packets that may be transmitted using contention access. Any message greater than this shall use reservation access.

Maximum Reservation Access Message Length:

Maximum_Reservation_Access_Message_Length is an 8-bit number representing the maximum length of a message in upstream packets that may be transmitted using a single reservation access. Any message greater than this is transmitted by making multiple reservation requests.

Downstream MPEG Connection Block Descriptor:

Table 51: Downstream_MPEG_CBD substructure

Downstream_MPEG_CBD(){	Bits	Bytes	Bit Number/Description
Downstream_Channel	32	4	
Program_Number	16	2	
}			

- **Downstream_Channel** is a 32-bit unsigned integer representing the Channel where the connection resides. The unit of measure is in Hz;
- **Program_Number** is a 16-bit unsigned integer uniquely referencing the downstream virtual connection assignment (PID of the MPEG-2 header, **not** equal to the program number defined by MPEG-2).

Upstream ATM Connection Block Descriptor:

Table 52: Upstream_ATM_CBD substructure

Upstream_ATM_CBD(){	Bits	Bytes	Bit Number/Description
Upstream_VPI	8	1	
Upstream_VCI	16	2	
Upstream_Channel_Id	8	1	
}			

- **Upstream_VPI** is an 8-bit unsigned integer representing the ATM Virtual Path Identifier that is used for upstream transmission over the Dynamic Connection;
- **Upstream_VCI** is a 16-bit unsigned integer representing the ATM Virtual Channel Identifier that is used for upstream transmission over the Dynamic Connection;
- **Upstream_Channel_Id**: Identification number of the up stream return channel. If the most significant bit of this field is set then the US channel is a "service" channel.

Number of Slots Defined:

Number_Slots_Defined is an 8-bit unsigned integer that represents the number of slot assignments contained in the message. The unit of measure is slots.

Slot Pattern

Slot_Pattern is a structure that represents the area pattern assigned to the NIU.

The structure is described below.

Table 53: Slot_Pattern structure

Slot_Pattern(){	Bits	Bytes	Bit Number/Description
Starting_Slot		4	
Time_Slot_Number	16		
Sub_Channel_Number	16		
Starting_Sub_Channel_Offset	8	1	
Number_Of_Sub_Channels	8	1	
Frame_Length	16	2	
}			

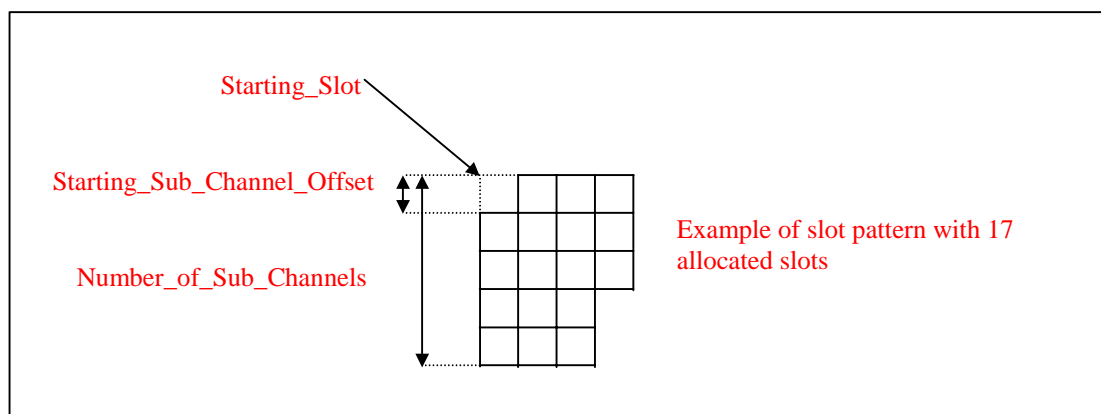

Figure 49: Slot Pattern Structure

- **Time_Slot_Number** is the 16 bit unsigned integer representing the number of the starting time slot;
- **Sub-Channel_Number** is a 16 bit unsigned integer giving the index of the sub channel to use;
- **Starting Sub-Channel Offset** is the offset (in number of sub-channels) between the starting slot and the first slot of the pattern;
- **Number of sub-channels** is an 8-bit unsigned integer representing the width of the pattern (in number of sub-channels);
- **Frame Length** is a 16 bit unsigned integer representing the total number of slots used (in the example above, there are 18 slots used).

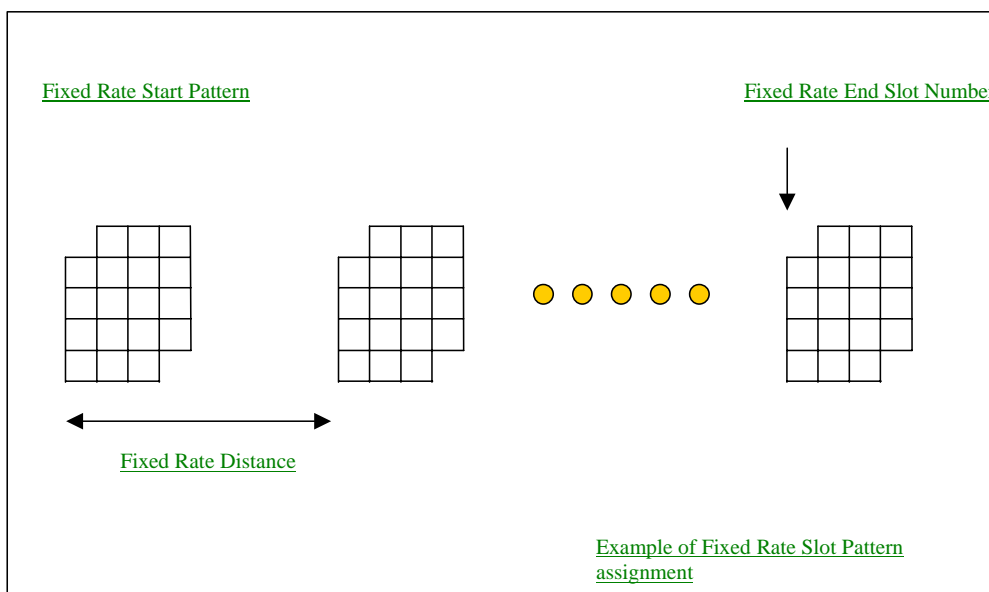

Figure 50: Fixed Rate Slot Pattern

Fixed Rate Start Pattern

Fixed Rate Start Pattern is the slot pattern structure described in figure 50, representing the first pattern that is granted to the NIU/RCTT within the fixed rate access region.

Fixed Rate Distance

Fixedrate_Distance - This 16-bit unsigned number representing the distance in time duration slots between additional slots assigned to the NIU. The NIU is assigned all slots that are a multiple of Fixedrate_Distance from the Fixedrate_Start_slot, which do not exceed Fixedrate_End_slot.

Fixed_Rate_End_Slot_Number

Fixed_Rate_End_Slot_Number - This 16-bit unsigned number indicating the last slot that may be used for fixed rate access. The slots assigned to the NIU, as determined by using the **Fixedrate_Start_slot**, the **Fixedrate_Distance** and the **Frame_length**, cannot exceed this number. Only 13 lowest significant bits are considered. 3 MSB are reserved for future use.

Downstream Multiprotocol Connection Block Descriptor

Table 54: Downstream_Multiprotocol_CBD substructure

Downstream_Multiprotocol_CBD(){	Bits	Bytes	Bit Number/Description
MAC_Address	48	6	
}			

MAC_Address is a 48-bit MAC address, identifying the only MAC address (for the connection established by this **<MAC> Connect_Message**) (used for example for multicast) to filter on in the DVB Multiprotocol Encapsulation header, according to EN 301 192 [5]. By default (for connections where no Downstream_Multiprotocol_CBD is given in the **<MAC> Connect_Message**) the NIU filters on its own MAC address and the Broadcast MAC address FF:FF:FF:FF:FF:FF.

Encapsulation is an 8-bit field that indicates the type of encapsulation provided: {Direct_IP, Ethernet_MAC_Bridging, PPP, Low_Latency_Telephony, Low_Latency_Telephony_Signalling, reserved 5..7}

User_Port_ID is a 16-bit unsigned integer that identifies the user port for which the incoming call is intended. If the most significant bit is set to 0, the remaining 15 bits indicate a PSTN user port in the range between 0 and 32 767. If the most significant bit is set to 1, the lowest 13 bits indicate an ISDN user port with a valid range between 0 and 8 175.

Source_IP_address is a 32-bit unsigned integer that identifies the IP address of the source of the IP packets to be transported within this connection.

Source_port_number is a 16-bit unsigned integer that identifies the port number of the source of the IP packets to be transported within this connection.

Destination_IP_address is a 32-bit unsigned integer that identifies the IP address of the destination of the IP packets to be transported within this connection.

Destination_port_number is a 16-bit unsigned integer that identifies the port number of the destination of the IP packets to be transported within this connection.

Source_Ethernet_MAC_address is a 48-bit unsigned integer that identifies the Ethernet MAC address of the source of the Ethernet frames to be transported within this connection.

Destination_Ethernet_MAC_address is a 48-bit unsigned integer that identifies the Ethernet MAC address of the destination of the Ethernet frames to be transported within this connection.

8.4.4.3 <MAC> Connect Response (Upstream Contention or Reserved)

The <MAC> **Connect Response Message** is sent to the INA from the NIU in response to the <MAC> **Connect Message**. If the Connect Confirm message does not arrive within the specified time interval, the NIU resends the Connect Response message.

Table 55: Connect response message structure

Connect_Response(){	Bits	Bytes	Bit Number/Description
Connection_ID	32	4	
}			

Connection ID:

Connection_ID is a 32-bit unsigned integer representing a global connection Identifier for the NIU Dynamic Connection.

8.4.4.4 <MAC> Connect Confirm (Singlecast Downstream)

The <MAC> **Connect Confirm Message** is sent from the INA to the NIU.

Table 56: Connect Confirm message structure

Connect_Confirm(){	Bits	Bytes	Bit Number/Description
Connection_ID	32	4	
}			

Connection ID:

Connection_ID is a 32-bit unsigned integer representing a global connection Identifier for the NIU Dynamic Connection.

8.4.4.5 Establishment of Additional Connections

The INA can assign additional connections by using the <MAC> **Connect Message** described previously. The NIU can request such connections using the <MAC> **Resource Request Message**. Besides that the message sequence is the same as for the initial connection, with the following restrictions:

- For one NIU, the US channel is the same for all connections;
- If a <MAC> **Connect Message** is received with new values of US channel, the NIU/RCTT ignores the message;

- If needed, the INA uses one of the resource management procedures to modify the US channel (see clauses 8.4.9.2 and 8.4.9.6 on TFDMA Allocation Management and Link Management, respectively) before sending the additional <MAC> **Connect Message**.

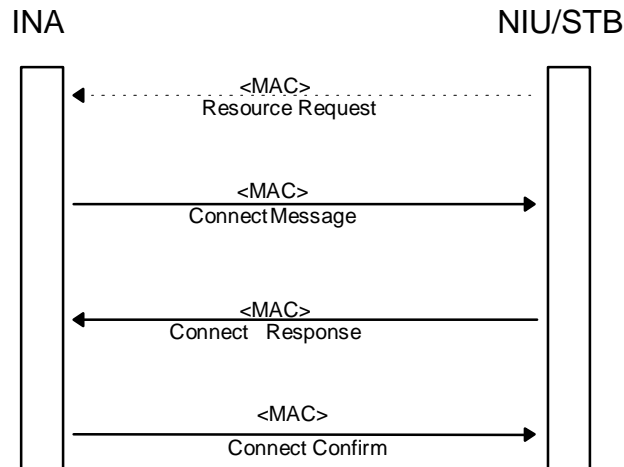

Figure 51: Connection signalling for additional connections

A more detailed description of the connection establishment process, including state diagrams and time outs, is given in annex E.

8.4.4.6 <MAC> Resource Request Message (Upstream)

The NIU may request a new connection, may request to change the parameters of an existing connection and may request to release an existing connection by sending a <MAC> **Resource Request Message** to the INA. The INA can reply to that request by sending a <MAC> **Connect Message**, a <MAC> **Reservation_ID Assignment Message**/**<MAC> Reprovision Message** or a <MAC> **Release Message**, respectively, to the NIU or by sending a <MAC> **Resource Request Denied Message** to the NIU.

Table 57: Resource Request Message Structure

Resource_Request_Message() {	Bits	Bytes	Bit Number/Description
Resource_Request_ID	8	1	
Connection_ID	32	4	
Request_Field		1	
Reserved	5		7..3: shall be zero
Release_Requested	1		2: {no, yes}
Reservation_ID_Requested	1		1: {no, yes}
Cyclic_Assignment_Needed	1		0: {no, yes}
Requested_Bandwidth	8	1	The unit is slots/100ms
Maximum_Distance_Between_Slots	16	2	The unit is slots
Encapsulation	8	1	
}			

Resource_Request_ID:

Resource_Request_ID is an 8-bit unsigned integer that helps to identify different resource requests from the NIU. The value of the **Resource_Request_ID** is incremented by one for every new resource request of the NIU. The INA rejects a resource request when the INA defined limit is reached. The value shall not be 0.

Connection_ID:

Connection_ID is a 32-bit field that identifies the connection for which changes are requested. If the value of **Connection_ID** is zero, a new connection is requested.

Request_Field:

- **Reserved:** reserved for future use. Shall be zero.
- **Release_Requested:** If set to one, the release of the connection is requested. In this case, all following parameters of the message are ignored by the INA.
- **Reservation_ID_Requested:** If set to one, a Reservation_ID is requested for the connection.
- **Cyclic_Assignment_Needed:** If set to one, cyclic assignment is requested for fixed rate access for the connection. If Requested_Bandwidth is zero, this field is ignored by the INA.

Requested_Bandwidth: Gives the requested bandwidth for fixed rate access for the connection in slots/100 ms.

Maximum_Distance_Between_Slots: Gives the requested maximum distance between assigned fixed rate slots. If Requested_Bandwidth is zero, this field is ignored by the INA.

Encapsulation:

Encapsulation is an 8-bit field that indicates the type of encapsulation requested: {Direct_IP, Ethernet_MAC_Bridging, PPP, reserved 3..7}.

8.4.4.7 <MAC> Resource Request Denied Message (Singlecast Downstream)

The INA may respond to a resource request of the NIU with a <MAC> Resource Request Denied Message:

Table 58: Resource Request Denied Message Structure

Resource_Request_Denied_Message() {	Bits	Bytes	Bit Number/Description
Resource_Request_ID	8	1	
}			

Resource_Request_ID:

Resource_Request_ID is an 8-bit unsigned integer that identifies the resource request that is denied.

8.4.5 Connection Release

This clause defines the MAC signalling requirements for connection release. Figure 52 displays the signalling flow for releasing a connection. The NIU can request the release of a connection using the <MAC> **Resource Request Message**.

- 1) The NIU may request the release of a connection using the <MAC> **Resource Request Message**, or the INA itself can initiate the release process.
- 2) Upon receiving the <MAC> **Release Message** from the INA, the NIU tears down the upstream connection established for the specified Connection_ID.
- 3) Upon teardown of the upstream connection, the NIU sends the <MAC> **Release Response Message** on the upstream channel previously assigned for that connection. If the Connection_ID is unknown by the NIU, it sends zero in the response message. If the Number_of_Connections in the Connection Release Message is zero, then the NIU releases all open connections.

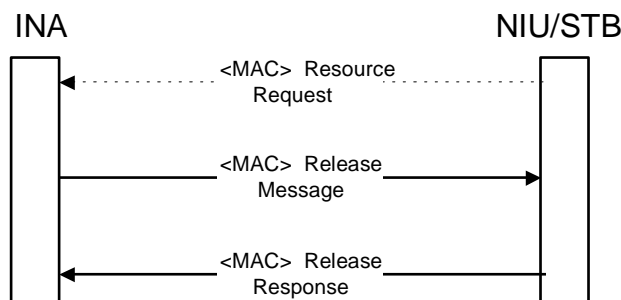

Figure 52: Connection release signalling

A more detailed description of the connection release process, including state diagrams and time outs, is given in annex E.

8.4.5.1 <MAC> Release Message (Singlecast Downstream)

The <MAC> **Release Message** is sent from the INA to the NIU to terminate a previously established connection.

Table 59: Release Message Structure

Release_Message(){	Bits	Bytes	Bit Number/Description
Number_of_Connections	8	1	
for(i=0;i<Number_of_Connections;i++){			
Connection_ID	(32)	(4)	
}			
}			

Connection ID:

Connection_ID is a 32-bit unsigned integer representing a global connection Identifier for the NIU Dynamic Connection.

8.4.5.2 <MAC> Release Response (Upstream contention or reserved)

The <MAC> **Release Response Message** is sent by the NIU to the INA to acknowledge the release of a connection. The format of the message is shown in table 60.

Table 60: Release Response Message structure

Release_Response_Message (){	Bits	Bytes	Bit Number/Description
Connection_ID	32	4	
}			

Connection ID:

Connection_ID is a 32-bit unsigned integer representing the global connection Identifier used by the NIU for this connection.

8.4.6 Fixed Rate Access

Fixed rate access is provided by the INA using the <MAC> **Connect Message**. The INA is also allowed to assign slots in fixed rate access to a connection in response to a <MAC> **Reservation Request Message**.

8.4.7 Contention Based Access

The NIU uses contention based slots specified by the **<MAC> Slot State Message** to transmit contention based messages or payload. The format of contention based MAC messages is described by the MAC message format (see clause 8.4.1).

The ranging slots can be used for fast and safe contention based bandwidth requests, the NIU/RCTT can send on the short-ranging sub-channels a bandwidth request code (see clause 6.8.3); when the INA receives these codes it knows that they are for bandwidth requests and allocates bandwidth to the NIU/RCTT for sending a **<MAC> Resource Request Message** in a safer than normal contention mode. The allocation is done at the Reservation Grant message using the time-slot, the sub-channel and the code as identification of the NIU/RCTT.

8.4.8 Reservation Access

This clause defines the MAC signalling requirements for reservation access. Figure 53 displays the signalling flow for reserving an access.

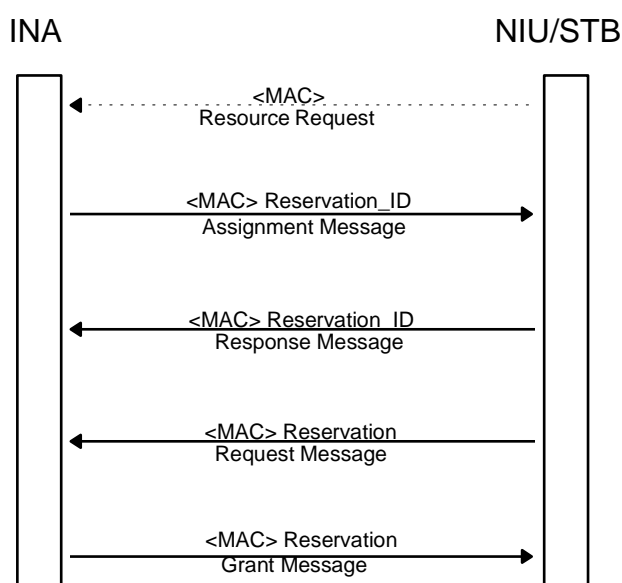

Figure 53: Reservation access signalling

- 1) The NIU can request a Reservation_ID using the **<MAC> Resource Request Message**.
- 2) The NIU waits for a **<MAC> Reservation ID Assignment Message** from the INA before it can request reservation access and before it can send Piggy Back Reservation Requests.
- 3) At any time after receiving the reservation ID, the NIU can request a certain number of slots to the INA using the **<MAC> Reservation Request Message**:
 - a) The INA responds to that message using the **<MAC> Reservation Grant Message**;
 - b) If the NIU has not received the **<MAC> Reservation Grant Message** before the Grant_Protocol_Timeout, it sends a **<MAC> Reservation Status Request Message** to the INA. This leads back to 3) or 4).
- 4) At any time after receiving the reservation ID, the NIU can request one of three pre-specified number of slots (specified by the Piggy_Back_Request_Values, which are set in the **<MAC> Reservation_ID_Assignment Message**) by setting the two MSBs of the GFC contained in any Upstream ATM cell owned by a given connection—to the correct corresponding value (01, 10 or 11; 00 indicates no requested Piggy Back reservation):
 - a) The INA responds to the Piggy Back request using the **<MAC> Reservation Grant Message**;
 - b) If the NIU has not received the **<MAC> Reservation Grant Message** before the Grant_Protocol_Timeout, it sends a **<MAC> Reservation Status Request Message** to the INA. This leads back to 4) or 3);

- c) It is allowed to use Continuous Piggybacking: Using this mechanism the NIU requests the minimum number slots possible (set of GFC_xx_Slots values) via a Piggybacking request in the last slot of a payload data upstream transmission even if no further data is in the upstream queue of the NIU. In the granted slot, an AAL5 frame with zero length can be sent upstream if no payload data is available. In this slot, also a piggybacking request for the minimum possible number of slots can be issued. Instead of using the piggybacking indication with a zero payload AAL5 frame, it is also allowed to send a reservation request message in the upstream slot with Reservation_Request_Slot_Count = 1. Short idle periods up to the length indicated in the Reservation ID Assignment Message can therefore be bridged without the need for contention access at the time where the next payload data is to be transferred. This improves the access delay, since the probability of collisions is avoided. On the other hand, some bandwidth might be wasted. It is up to the INA to set the maximum time for the bridging period (Continuous_Piggy_Timeout in the <MAC>Reservation_ID_Assignment_Message or the <MAC>Default_Configuration_Message) by taking into account the trade-off between throughput and access delay.

A more detailed description of the reservation process, including state diagrams and time outs, is given in annex E.

8.4.8.1 <MAC> Reservation ID Assignment Message (Singlecast Downstream)

The <MAC> Reservation ID Assignment Message is used to assign the NIU a Reservation_ID. In addition, the <MAC> Reservation_ID_Assignment_Message contains the three different reservation grant sizes used in the Piggy Back procedure and the timeout for continuous piggybacking. The NIU identifies its entry in the <MAC> Reservation_Grant Message by comparing the Reservation_ID assigned to it by the <MAC> Reservation_ID_Assignment Message and the entries in the <MAC> Reservation_Grant Message.

The format of the message is given in table 61.

Table 61: Reservation ID assignment message structure

Reservation_ID_Assignment_Message (){	Bits	Bytes	Bit Number/Description
Connection_ID	32	4	
Reservation_ID	16	2	
Grant_Protocol_Timeout	16	2	
Piggy_Back_Request_Values {		4	
Continuous_Piggy_Back_Timeout	8	1	Unit is the slot
GFC_11_Slots	8	1	
GFC_10_Slots	8	1	
GFC_01_Slots	8	1	
}			
}			

Connection ID:

Connection_ID is a 32-bit unsigned integer representing a global connection identifier for the NIU Dynamic Connection.

Reservation_ID:

Reservation_ID is a 16-bit unsigned number representing an identifier for the connection. This is used as a short identifier by the NIU to identify the appropriate <MAC> Reservation_Grant Message.

Grant_Protocol_Timeout:

Grant_Protocol_Timeout is a 16-bit unsigned number representing the time in milliseconds that the NIU shall wait before verifying the status of pending grants. This parameter specifies the time that the NIU shall wait after receiving the last <MAC> Reservation_Grant Message, with an entry addressed to the NIU, before initiating a reservation status request. If the NIU has pending grants and the timeout occurs, it shall send the <MAC>

Reservation_status_request Message to the INA. The INA responds with the <MAC> Reservation_Grant Message (probably without granting any slots) to inform the NIU of any remaining slots left to be granted. This allows the NIU to correct any problem should they exist such as issuing an additional request for slots or waiting patiently for additional grants.

Piggy_Back_Request_Values:

Continuous_Piggy_Back_Timeout is an 8-bit unsigned integer value representing the time period that can be bridged using the Continuous Piggybacking mechanism. The unit of the value is slot. The timeout value indicates how long a NIU is allowed to request upstream slots with an empty payload data upstream queue after the first continuous piggybacking request was sent on the upstream channel. In order to offer an improved transmission performance (if the traffic characteristics are taken into account) a time period of up to 254 slots can be bridged without using contention slots. If the value is set to zero, Continuous Piggybacking is disabled. If the value is set to 255, the timeout period is infinite.

- **GFC_11_Slots** is an 8-bit unsigned value representing the number of slots being requested if the NIU sets the two MSBs of the GFC to a value of 11.
- **GFC_10_Slots** is an 8-bit unsigned value representing the number of slots being requested if the NIU sets the two MSBs of the GFC to a value of 10.
- **GFC_01_Slots** is an 8-bit unsigned value representing the number of slots being requested if the NIU sets the two MSBs of the GFC to a value of 01.

8.4.8.2 <MAC> Reservation ID Response Message (Upstream contention or reserved)

The <MAC> **Reservation ID Response Message** is used to acknowledge the receipt of the <MAC> **Reservation_ID_Assignment Message**.

The format of the message is given below.

Table 62: Reservation ID Response Message structure

Reservation_ID_Response_Message () {	Bits	Bytes	Bit Number/Description
Connection_ID	32	4	
Reservation_ID	16	2	
}			

Connection ID:

Connection_ID is a 32-bit unsigned integer representing a global connection identifier for the NIU/RCTT Dynamic Connection.

Reservation_ID:

Reservation_ID is a 16 bit unsigned number representing an identifier for the connection. This is used as a short identifier by the NIU/RCTT to identify the appropriate <MAC> **Reservation_Grant Messages**.

8.4.8.3 <MAC> Reservation Request Message (Upstream contention or reserved)

Table 63: Reservation Request Message structure

Reservation_Request_message () {	Bits	Bytes	Bit Number/Description
Reservation_ID	16	2	
Reservation_Request_Slot_Count	8	1	
}			

This message is sent from the NIU to the INA.

Reservation_ID:

Reservation_ID is a 16-bit unsigned number representing an identifier for the connection. This is used as a short identifier by the NIU to identify the appropriate Reservation_Grant_Messages.

Reservation Request Slot Count:

Reservation_Request_Slot_Count is an 8-bit unsigned number representing the number of slots requested by the NIU. This is the number of slots that is allocated in the upstream channel. The INA responds with the <MAC> **Reservation Grant Message** granting the request.

8.4.8.3.1 <MAC> Reservation Grant Message (Broadcast Downstream)

The <MAC> **Reservation Grant Message** is used to indicate to the NIU which slots have been allocated in response to the Reservation Request message. The NIU identifies its entry in the Reservation_grant_message by comparing the Reservation_ID assigned to it by the <MAC> **Reservation_ID Assignment Message** and the entries in the <MAC> **Reservation_Grant Message**.

The format of the message is given in table 64.

Table 64: Reservation Grant Message structure

Reservation_grant_message ()	Bits	Bytes	Bit Number/Description
Reference_Time_Slot_Number	16	2	
Number_grants	8	1	
<i>For (i=0; i<Number_grants; i++){</i>			
Reservation_ID	(16)	(2)	
Grant_Pattern		(7)	
Sub_Channel_Number	(16)	(2)	
Frame_Length	(16)	(2)	
Starting_Sub_Channel_Offset	(8)	(1)	
Number_Of_Sub_Channels	(8)	(1)	
Time_Slot_Offset	(8)	(1)	
Remaining_Slot_Count	(8)	(1)	
<i>}</i>			
Number_Ranging_Grants	8	1	
<i>For (i=0; i<Number_Ranging_Grants; i++){</i>			
Ranging_Id		(4)	
Time_Slot_Number	(16)	(2)	
Time_Symbol_Number	(8)	(1)	
Ranging_Code	(8)	(1)	
Ranging_Sub_Channel_Number	(8)	(1)	
Grant_Slot		(3)	
Sub_Channel_Number	(16)	(2)	
Time_Slot_Offset	(8)	(1)	
<i>}</i>			
<i>}</i>			

Reference_Time_Slot_Number:

Reference_Time_Slot_Number is the time slot number indicating the reference point for the remaining parameters of this message.

Number_grants:

Number_grants is an 8-bit unsigned number representing the number of grants contained within this message. This can either correspond to grants for different NIUs or to different Connection_IDs for the same NIU.

Reservation_ID:

Reservation_ID is a 16-bit unsigned number representing an identifier for the connection. This is used as a short identifier by the NIU to identify the appropriate <MAC> **Reservation_Grant Messages**.

Grant_Pattern:

- **Sub_Channel_Number** is a 16-bit unsigned integer giving the index of the sub-channel to be used. The numeration of the sub-channels in MAS3 is in multiples of 10 (see clause 6.8.3 of PHY spec), this means that 0 represent the first sub-channel, 10 the second etc, those numeration are for sub-channels of BS3, for each sub-channel of BS3 there could be 7 sub-channels of BS2, the INA can decide that specific BS3 sub-channel will be used of BS2, then the numeration will be, for sub-channel X: X + 1 for first BS2 sub-channel, X + 2 for the second etc. For example: 31, 32, 33 This means that the distinction between sub-channels of the different bursts is denoted directly from the numeration used.
- **Frame_Length** is an 8-bit unsigned number representing the number of slots currently granted for the upstream burst. A value of zero indicates that no slots are being granted. This would typically be the case in a response to a <MAC> **Reservation_status_request Message**. Upon receipt of this message the NIU is assigned Grant_slot_count slots in the upstream channel starting at the position indicated by the Reference_slot indexed by the Starting_Sub_Channel_Offset.
- **Starting_Sub_Channel_Offset** is the offset (in number of sub-channels) between the starting slot and the first slot of the pattern.
- **Number_Of_Sub_Channels** is an 8-bit unsigned integer representing the width of the pattern (in number of sub-channels).
- **Time_Slot_Offset** is an 8-bit unsigned number representing the starting time slot number to be used for the upstream pattern. This number is added to the Reference_Time_Slot to determine the absolute time slot.

Remaining_Slot_Count:

Remaining_Slot_Count is an 8-bit unsigned number representing the remaining slots to be granted by the INA with subsequent grant messages. A value of 0x1F indicates that 31 or more slots will be made available in the future. A value of 0x00 indicates that no additional slots will be granted in the future and that the slots granted in this message represent the only remaining slots available for the connection. The NIU should monitor this count to determine if sufficient slots remain to satisfy current needs. Should additional slots be required because of lost grant messages or additional demand, additional slots should be requested using the <MAC> **Reservation_Request Message**. Additional <MAC> **Reservation_Request Messages** are sent only when the Remaining_Slot_Count is less than 15. To minimize contention on the upstream channel, the <MAC> **Reservation_Request Message** may be sent in one of the slots granted by the <MAC> **Reservation_grant Message**. The remaining slot count is calculated for each grant in a <MAC> **Reservation Grant Message**.

Ranging_Id

Ranging_Id defines the received Ranging bandwidth request code from the NIU. The bandwidth allocation is addressed to a specific NIU using this field.

- **Time_Slot_Number** is a numerical value that represents the time slot index in which the Ranging bandwidth request code was sent.
- **Time_Symbol_Number** is a numerical value that represents the first time symbol in which the Ranging bandwidth request code was sent, among the time-symbols of the ranging slot.
- **Ranging_Code** field represents the Ranging bandwidth request code that was sent by the NIU/RCTT.
- **Ranging_Sub_Channel_Number** represents the ranging sub_channel used by the NIU/RCTT.

Grant_Slot:

- **Sub_Channel_Number** is a 16 bit unsigned integer giving the index of the sub-channel to use.
- **Time_Slot_Offset** is an 8-bit unsigned number representing the starting time slot number to be used for the upstream pattern. This number is added to the Reference_Time_Slot to determine the absolute time slot.

8.4.8.4 <MAC> Reservation Status Request (Upstream contention or reserved)

The <MAC> **Reservation Status Request Message** is used to determine the status of the outstanding grants to be assigned by the INA. This message is only sent after the Grant protocol time-out is exceeded. The INA responds with the Reservation Grant Message (possibly without granting any slots) to inform the NIU of any remaining slots left to be granted. This allows the NIU to correct any problems should they exist such as issuing an additional request for slots or waiting patiently for additional grants.

The format of the message is given in table 65.

Table 65: Reservation status request message structure

Reservation_Status_Request_Message ()	Bits	Bytes	Bit Number/Description
Reservation_ID	16	2	
Remaining_request_slot_count	8	1	
}			

Reservation_ID:

Reservation_ID is a 16-bit unsigned number representing an identifier for the connection. This is used as a short identifier by the NIU to identify the appropriate <MAC> **Reservation_Grant Messages**.

Remaining_request_slot_count:

Remaining_request_slot_count is an 8-bit unsigned number representing the number of slots that the NIU is expecting to be granted.

8.4.9 MAC Link Management

The MAC Link Management tasks provide continuous monitoring and optimization of upstream resources. These functions include:

- Power and Timing Management;
- Fixed rate Allocation Management;
- Channel Error Management.

8.4.9.1 Power and Timing Management

Power and Timing Management provides continuous monitoring of upstream transmission from the NIU.

<MAC>**Ranging and Power Calibration Message** is a downstream message that can be used to maintain a NIU within predefined thresholds of power, frequency and time. The Upstream Burst Demodulator continuously monitors the upstream burst transmissions from an NIU. Upon detection of an NIU outside the predefined range, the INA sends the <MAC> **Ranging and Power Calibration Message** to the NIU.

The NIU/RCTT upstream transmitted power resolution shall be 3 dB.

A detailed description of the recalibration process, including state diagrams and time outs, is given in annex E.

8.4.9.2 TFDMA Allocation Management

To ensure optimum assignment of TFDMA resources, the INA ensures the upstream allocation of TFDMA resources for various connections remain intact when allocating resources to a new connection. However, in the event that reconfiguration is required to minimize fragmentation of resources, then the INA shall dynamically reconfigure the upstream TFDMA assignments to a NIU or group of NIUs. The <MAC> **Reprovision Message** is utilized to change previously established connection parameters.

The NIU can request the change of some parameters of existing connections by use of the <MAC> **Resource Request Message**, in which case the <MAC> **Reprovision Message** can be used by the INA to confirm the requested changes.

A detailed description of the reprovisioning process, including state diagrams and time outs, is given in annex E. For a SDL description of upstream channel changes, see annex E.

8.4.9.3 <MAC> Reprovision Message (Singlecast Downstream)

The <MAC> **Reprovision Message** is sent by the INA to the NIU to reassign upstream resources (maintaining the originally requested QoS parameters at the establishment of the connection). This message is intended for fixed rate based channel maintenance by the INA to redistribute or reassign resources allocated to a NIU.

Table 66: Reprovision Message structure

Reprovision_Message (){	Bits	Bytes	Bit Number/Description
Reprovision_Control_Field		1	
Reserved	1		7
Delete_Reservation_Ids	1		6: {no,yes}
Reserved	2		5..4: 0
New_Upstream_Channel_Included	1		3: {no,yes}
New_Downstream_Channel_Included	1		2: {no,yes}
New_Cyclical_Assignment_Included	1		1: {no,yes}
New_Slot_List_Included	1		0: {no,yes}
<i>if (Reprovision_Control_Field and=</i> <i>New_Upstream_Channel_Included) {</i>			
New_Upstream_Channel	(8)	(1)	
<i>}</i>			
<i>if (Reprovision_Control_Field and=</i> <i>New_Downstream_Channel_Included) {</i>			
New_Downstream_Channel	(32)	(4)	
<i>}</i>			
<i>if (Reprovision_Control_Field and=</i> <i>New_Slot_List_Included </i> <i>New_Cyclical_Assignment_Included </i> <i>Delete_Reservation_IDs){</i>			
Number_of_Connections	(8)	(1)	
<i>for(I=0;I<Number_of_Connections;i++){</i>			
Connection_ID	(32)	(4)	
<i> if(Reprovision_Control_Field and=</i> <i> New_Slot_List_Included){</i>			Fixed Rate Access
Number_Slots_Defined	(8)	(1)	
<i> for(i=0;i<Number_Slots_Assigned;i++){</i>			
Slot_Pattern	(64)	(8)	
<i> }</i>			
<i> }</i>			
<i> if (Reprovision_Control_Field and=</i> <i> New_Cyclical_Assignment_Included){</i>			Fixed Rate Access
Fixedrate_Start_Pattern	(64)	(8)	
Fixedrate_Distance	(16)	(2)	
Fixed_Rate_End_Slot_Number	(16)	(2)	
<i> }</i>			
<i>}</i>			
<i>}</i>			

Reprovision Control Field:

Reprovision_Control_Field specifies what modifications to upstream resources are included. It consists of the following sub fields:

- **Delete_Reservation_IDs** is a Boolean that indicates that the NIU/RCTT deletes all Reservation_IDs that have been assigned to the Connection_IDs contained in this message.
- **New_Upstream_Channel_Included** is a Boolean that indicates that a new upstream channel is specified in the message.

- **New_Downstream_Channel_Included** is a Boolean that indicates that a new downstream channel is specified in the message.
- **New_Cyclical_Assignment_Included** is a Boolean that indicates that a new cyclical assignment is specified in the message. If the connection has already cyclic fixed rate slots or a slot list assigned, these slots are lost. Having Cyclic Assignments and Slot List Assignments for the same Connect_ID at the same time is not allowed.
- **New_Slot_List_Included** is a Boolean that indicates that a new slot list is specified in the message. If the connection has already cyclic fixed rate slots or a slot list assigned, these slots are lost. Having Cyclic Assignments and Slot List Assignments for the same Connect_ID at the same time is not allowed.

New Upstream Channel:

This is an 8-bit unsigned integer representing upstream channel identifier.

New Downstream Channel:

This is a 32-bit unsigned integer representing the reassigned upstream carrier centre channel. The unit of measure is Hertz (Hz).

Number_of_Connections:

This is an 8-bit unsigned integer that represents the number of connections to which the reprovisioning of slots applies.

Connection_ID:

This is a 32-bit unsigned integer identifying the connections that are affected by the reprovisioned slots.

Number of Slots Defined:

This is an 8-bit unsigned integer that represents the number of slot assignments contained in the message. The unit of measure is slots.

Slot Pattern:

This is a structure that represents the Fixed Rate based pattern assigned to the NIU.

Fixed Rate Start Pattern:

This is the slot pattern structure described above, representing the first pattern that is granted to the NIU/RCTT within the fixed rate access region.

Fixed Rate Distance

This 16-bit unsigned number represents the distance in time duration slots between additional slots assigned to the NIU. The NIU is assigned all slots that are a multiple of Fixedrate_Distance from the Fixedrate_Start_slot that do not exceed Fixedrate_End_slot.

Fixed_Rate_End_Slot_Number:

This 16-bit unsigned number indicates the last slot that may be used for fixed rate access. The slots assigned to the NIU, as determined by using the Fixedrate_Start_slot, the Fixedrate_Distance and the Frame_length, cannot exceed this number. Only 13 lowest significant bits are considered. 3 MSB are reserved for future use.

8.4.9.4 Channel Error Management

During periods of connection inactivity (no upstream MAC transmission by an NIU), the NIU enters the Idle Mode. Idle mode is characterized by periodic transmission by the NIU of a <MAC> **Idle Message**. The Idle Mode transmission occurs at a periodic rate sufficient for the INA to establish Packet Error Rate statistics. The Idle Message is sent only when the NIU/RCTT has at least one connection, after the <MAC> **Connect Confirm Message** is received.

A detailed description of idle message transmission, including state diagrams and timeouts, is given in annex E.

8.4.9.5 <MAC> Idle Message (Upstream contention or reserved)

The <MAC> **Idle Message** is sent by the NIU within the RCTT to the INA at predefined intervals (between 1 minute and 10 minutes) when the NIU is in idle mode. However, the INA may disable sending Idle Messages by sending a value of zero in the Idle_Interval field contained in the <MAC> **Default Configuration Message**.

Table 67: Idle Message structure

Idle_Message(){	Bits	Bytes	Bit Number/Description
Idle_Sequence_Count	8	1	
Power_Control_Setting	8	1	
}			

Idle Sequence Count:

Idle_Sequence_Count is an 8-bit unsigned integer representing the count (modulo 256) of <MAC> **Idle Messages** transmitted while the NIU is Idle. It counts the number of transmitted Idle Messages since the last sign-on, thus it starts counting at 0.

Power Control Setting:

Power_Control_Setting is an 8-bit unsigned integer representing the actual power used by the NIU/RCTT for upstream transmission. The unit of measure is dBm. A value of zero represents -50 dBm. Each increment of this value is in steps of 3 dBm.

8.4.9.6 Link Management Messages

<MAC> Configuration Message (Singlecast or Broadcast Downstream)

The <MAC> **Configuration Message** is sent by the INA to the NIU to change certain MAC parameters that were initially set during the Initialization and Provisioning, the Sign-On and Calibration, and Connection Establishment procedures.

A detailed description of the configuration process, including state diagrams and time outs, is given in annex E.

Table 68: Configuration Message structure

Configuration(){	Bits	Bytes	Bit Number/Description
Configuration_Control_Field		2	
Reserved	8		15..8
New_MAS3_Boundary	1		7: {no,yes}
Ranging_Control_Field	1		6: {no,yes}
New_Max_Reservation_Size	1		5: {no,yes}
New_Max_Contention_Size	1		4: {no,yes}
New_PBR_Values	1		3: {no,yes}
New_Idle_Interval	1		2: {no,yes}
New_Min_Backoff	1		1: {no,yes}
New_Max_Backoff	1		0: {no,yes}
Ranging_Control_Field	16	2	
Ranging_Interval_Size	4		15..12
Short_Ranging	12		11..0
<i>if (Configuration_Control_Field and= New_MAS3_Boundary) {</i>			
Upstream_Channel_Start		(1)	
Upstream_Channel_End		(1)	
<i>}</i>			
<i>if (Configuration_Control_Field and= New_Max_Backoff) {</i>			
Max_Backoff_Exponent	(8)	(1)	
<i>}</i>			
<i>if (Configuration_Control_Field and= New_Min_Backoff) {</i>			
Min_Backoff_Exponent	(8)	(1)	
<i>}</i>			

Configuration(){	Bits	Bytes	Bit Number/Description
<i>If (Configuration_Control_Field and=</i> <i>New_Idle_Interval) {</i>			
Idle_Interval	(16)	(2)	
<i>}</i>			
<i>If (Configuration_Control_Field and=</i> <i>New_PBR_Values) {</i>			
Piggy_Back_Request_Values {		(4)	
Continuous_Piggy_Back_Timeout	(8)	(1)	Unit is in slots
GFC_11_Slots	(8)	(1)	
GFC_10_Slots	(8)	(1)	
GFC_01_Slots	(8)	(1)	
}			
<i>}</i>			
<i>If (Configuration_Control_Field and=</i> <i>New_Max_Contention_Size) {</i>			
Max_Contention_Message_Length	(8)	(1)	
<i>}</i>			
<i>If (Configuration_Control_Field and=</i> <i>New_Max_Reservation_Size) {</i>			
Max_Reservation_Message_Length	(8)	(1)	
<i>}</i>			
<i>If (Configuration_Control_Field and=</i> <i>New_Max_Contention_Size </i> <i>New_Max_Reservation_Size </i> <i>New_PBR_Values) {</i>			
Number_of_Connections	(8)	(1)	
for(i=0;i<Number_of_Connections;i++)			
Connection_ID	(32)	(4)	
}			
<i>}</i>			
<i>}</i>			

Configuration Control Field:

Configuration_Control_Field specifies what modifications to per-connection parameters are included. It consists of the following sub fields:

- **Reserved:** Reserved for future use.
- **New_MAS3_Boundary** is a Boolean field indicating that the INA has changed the boundary of the MAS3 upstream channel.
- **Ranging_Control_Field** is a Boolean, that when set indicates that new ranging parameters are included in the message.
- **New_Max_Reservation_Size** is a Boolean, that when set indicates that a new Maximum Reservation Access Message Length is included in the message.
- **New_Max_Contention_Size** is a Boolean, that when set indicates that a new Maximum Contention Access Message Length is included in the message.
- **New_PBR_Values** is a Boolean, that when set indicates that new Piggy Back Request Values are included in the message.
- **New_Idle_Interval** is a Boolean, that when set indicates that a new Idle Interval is included in the message.
- **New_Min_Backoff** is a Boolean, that when set indicates that a new Minimum Backoff Exponent is included in the message.
- **New_Max_Backoff** is a Boolean, that when set indicates that a new Maximum Backoff Exponent is included in the message.

Ranging_Control_Field:

Ranging_Interval_Size is a 4-bit integer representing the number of ranging time slots for MAS1 and MAS2. The allocation is in multiples of 6 time slots.

Short_Ranging is a 12-bit unsigned integer representing the short ranging sub-channel(s), this field has two uses according to the selected access scheme (MAS 1, 2 or 3).

- For **MAS1** and **MAS2** the Short_Ranging field represents the short ranging sub-channels in the ranging time slot, possible values are 0..4 095 for 2K mode and 0..63 for 1K mode, the sub-channels are determined from the binary representation of the integer value.
- For **MAS3** the Short_Ranging field represent the ranging sub-channel from all the sub-channels, possible values are: 0..11 for 2K mode and 0..5 for 1K mode, the value represents the sub-channel reserved for ranging access.

When working in MAS1 or MAS2 in 2K carriers mode, for each ranging symbol there are 12 possible ranging sub-channels for each ranging time symbol.

The **Short Ranging field** will define which of the sub-channels shall be used for short ranging purposes.

If, for example, sub-channels 0, 2, 3, 8 and 10 (when enumerated from 0-11) should be used for short ranging and all others should be used for long ranging, the bitmap representing the short ranging sub-channels would be:

010100001101, the **Short_Ranging field** will have the decimal value of the bitmap, meaning:
 $2^0 + 2^2 + 2^3 + 2^8 + 2^{10} = 1\ 293$ which will be equivalent to the bitmap (refer to figure 45).

For 1K mode, only 6 ranging sub-channels exists for each ranging time symbol, for this case, bitmap of 6 bits is needed to represent the sub-channels. For the 1K mode, the possible values for the Short_Ranging field are 0..63, the mapping of the sub-channels is done as in the 2K mode.

When working in MAS3, there are 12 (6) sub-channels for each time symbol in 2K (1K) carriers mode, one of the sub-channels is used as a ranging sub-channel.

The **Short-Ranging field**, in this case, will indicate which one on the sub-channels will be used as ranging sub-channel. In this case, the Short_Ranging field will represent the number of the sub-channel that is used for ranging, meaning that if **Short_Ranging** = 3 then sub-channel number 3 shall be used for ranging and all other sub-channels are "data" sub-channels.

Upstream-Channel Start:

Upstream channel start is an 8-bit unsigned integer containing a BS3 sub-channel number. This number indicates the first used data sub-channel number in the upstream channel.

Upstream-Channel End:

Upstream channel end is an 8-bit unsigned integer containing a BS3 sub-channel number. This number indicates the last used data sub-channel number in the upstream channel.

MAX_Backoff_Exponent:

MAX_Backoff_Exponent is an 8-bit unsigned integer representing the maximum value of the backoff exponent counter. Only the 5 least significant bits are valid, the 3 most significant bits are reserved for future use.

MIN_Backoff_Exponent:

MIN_Backoff_Exponent is an 8-bit unsigned integer representing the minimum value of the backoff exponent counter.

Idle_Interval:

Idle_Interval is a 16-bit unsigned integer representing the predefined interval for the Idle Messages. The unit of the measure is in seconds. The value of zero indicates that no <MAC> **Idle Messages** are sent.

Piggy_Back_Request_Values:

Continuous_Piggy_Back_Timeout is an 8-bit unsigned integer value representing the time period that can be bridged using the Continuous Piggybacking mechanism. The unit of the value is the slot. The timeout value indicates how long a NIU is allowed to request upstream slots with an empty payload data upstream queue after the first continuous piggybacking request was sent on the upstream channel. In order to offer an improved transmission performance (if the traffic characteristics are taken into account) a time period of up to 254 slots can be bridged without using contention slots. If the value is set to zero, Continuous Piggybacking is disabled. If the value is set to 255, the timeout period is infinite.

- **GFC_11_Slots** is an 8-bit unsigned value representing the number of slots being requested if the NIU sets the two MSBs of the GFC to a value of 11.
- **GFC_10_Slots** is an 8-bit unsigned value representing the number of slots being requested if the NIU sets the two MSBs of the GFC to a value of 10.
- **GFC_01_Slots** is an 8-bit unsigned value representing the number of slots being requested if the NIU sets the two MSBs of the GFC to a value of 01.

Max_Contention_Message_Length:

Max_Contention_Message_Length is an 8-bit unsigned integer representing the maximum length of a message in ATM sized cells that may be transmitted using contention access. Any message greater than this shall use reservation access.

Max_Reservation_Message_Length:

Max_Reservation_Message_Length is an 8-bit unsigned integer representing the maximum length of a message in ATM sized cells that may be transmitted using a single reservation access. Any message greater than this is transmitted by making multiple reservation requests.

Number_of_Connections:

Number_of_Connections is an 8-bit unsigned integer that represents the number of connections to which the change in Max_Contention_Message_Length and/or Max_Reservation_Message_Length applies.

Connection_ID:

Connection_ID is a 32-bit unsigned integer identifying the connections that are affected by the new parameters Max_Contention_Size, Max_Reservation_Size and New_PBR_Values (all Reservation_Ids of the specified connection are affected).

8.4.9.7 <MAC> Transmission Control Message (Singlecast or Broadcast Downstream)

The <MAC> **Transmission Control Message** is sent to the NIU from the INA to control several aspects of the upstream transmission. This includes stopping upstream transmission, re-enabling transmission from a NIU or group of NIUs and rapidly changing the upstream channel being used by a NIU or group of NIUs (see clause 8.1.1.2).

When it is required to switch the upstream channel/downstream channel of a group of NIUs at the same time, the <MAC> **Transmission Control Message** is sent in broadcast mode with the Old_Upstream_Channel/Old_downstream_Channel included in the message. When broadcast with the Old_Upstream_Channel/Old_downstream_Channel, the NIU compares its current channel value to the Old_Upstream_Channel/Old_downstream_Channel. When equal, the NIU switches to the new channel specified in the message. When unequal, the NIU ignores the new channel and remains on its current channel.

A detailed description of the transmission control process, including state diagrams and time outs, is given in annex E.

Table 69: Transmission Control Message structure

Transmission_Control_Message(){	Bits	Bytes	Bit Number/Description
Transmission_Control_Field		1	
Reserved	2		7..6: 0
Change_timeouts	1		5: {no, yes}
Stop_Upstream_Transmission	1		4: {no, yes}
Start_Upstream_Transmission	1		3: {no, yes}
Old_Channel_Included	1		2: {no, yes}
Switch_Downstream_Channel	1		1: {no, yes}
Switch_Upstream_Channel	1		0: {no, yes}
<i>if (Transmission_Control_Field and=</i> <i>Switch_Upstream_Channel andand</i> <i>Old_Channel_Included){</i>			
Old_Upstream_Channel	(8)	(1)	
<i>}</i>			
<i>if (Transmission_Control_Field and=</i> <i>Switch_Upstream_Channel){</i>			
New_Upstream_Channel	(8)	(1)	
<i>}</i>			
<i>if (Transmission_Control_Field and=</i> <i>Switch_Downstream_Channel andand</i> <i>Old_Channel_Included){</i>			
Old_Downstream_Channel	(32)	(4)	
<i>}</i>			
<i>if (Transmission_Control_Field and=</i> <i>Switch_Downstream_Channel){</i>			
New_Downstream_Channel	(32)	(4)	
<i>}</i>			
New_Upstream_Control_Field		(2)	
Reserved	1		15
Freq_Hopping	1		14
Coding	2		13..12
Shaping	1		11
FFT_Size	1		10
Mode	2		9..8
Guard_Interval	2		7..6
Modulation	2		5..4
Code_Rate	2		3..2
Medium_Access	2		1..0
<i>if (Transmission_Control_Field and=</i> <i>Change_Timeouts){</i>			
Number_of_Timeouts	(8)	(1)	
<i>for (i=0; i < Number_of_Timeouts;i++) {</i>			
Timer_Field		(1)	
Code	(4)		
Value	(4)		
<i>}</i>			
<i>}</i>			
<i>}</i>			

Transmission Control Field:

Transmission_Control_Field specifies the control being asserted on the upstream channel:

- **Change_Timeouts** is a Boolean, that when set indicates that timeout codes and values are included in the message. These timeouts are to be taken into account by the NIU in any case, even if the parameters **Old_Upstream_Channel** do not match.
- **Stop_Upstream_Transmission** is a Boolean, that when set indicates that the NIU shall enter the "stopped" state without sending a <MAC> **Link_Management_Response Message**, whilst in the "stopped" state, the NIU ignores all downstream MAC messages except <MAC> **Transmission_Control Messages** and <MAC> **Ranging_and_Power_Calibration Messages**. <MAC> **Transmission_Control Messages** are processed, but no <MAC> **Link_Management_Response Messages** are sent. <MAC> **Ranging_and_Power_Calibration Messages** are processed.

- **Start_Upstream_Transmission** is a Boolean, that when set indicates that the Network Interface Unit, if it is in "stopped" state currently, shall re-enter, or attempt to re-enter (in the case of having received an <MAC> **Initialization_Complete_Message** containing a non-zero Completion_Status_Field) the "running" state by signing on and resuming transmission on its upstream channel.
- **Old_Channel_Included** is a Boolean that when set indicates that the Old Upstream Channel or the Old Downstream Channel value is included in the message and shall be used to determine if a switch in channel is necessary.
- **Switch_Downstream_Channel** is a Boolean, that when set indicates that a new Downstream channel is included in the message.
- **Switch_Upstream_Channel** is a Boolean, that when set indicates that a new upstream channel is included in the message.

Typically, the Switch_Upstream_Channel and the Stop_Upstream_Transmission are set simultaneously to allow the NIU to stop transmission and change channel. This would be followed by the <MAC> **Transmission Control Message** with the Start_Upstream_Transmission bit set.

Old Upstream Channel:

Old_Upstream_Channel is an 8-bit unsigned integer representing the channel that shall be used by the NIU to compare with its current channel to determine if a change in channel is required.

New Upstream Channel:

New_Upstream_Channel is an 8-bit unsigned integer representing the reassigned upstream channel.

Old Downstream Channel:

Old_Downstream_Channel is a 32-bit unsigned integer representing the centre frequency of the downstream channel that shall be used by the NIU to compare with its current DS channel to determine if a change in channel is required. The unit is Hertz (Hz).

New Downstream Channel:

New_Downstream_Channel is a 32-bit unsigned integer representing the reassigned centre frequency of the downstream channel. The unit is Hertz (Hz).

New_Upstream_Control_Field:

- Gives the default physical characteristics of the upstream physical channel, if the New_Upstream_Channel value is the same as Old_Upstream_Channel, then this field is used to modify the physical parameters of current upstream channel.
- **Freq_Hopping:** is a Boolean field indicating that the RCTTs shall access the channel using Frequency Hopping technique.
- **Coding:** Defines the coding scheme: 0 = Reed Solomon; 1 = Turbo Code; other 2 values reserved.
- **Shaping:** Defines the pulse shaping, 0 = Nyquist; 1 = Rectangular.
- **FFT_Size:** Defines the system FFT size: 0 = 1K; 1 = 2K.
- **Mode:** Defines the working symbol rate, Values 0 to 2 mean Mode 1 to Mode 3.
- **Guard_Interval:** 0 = 1/4; 1 = 1/8; 2 = 1/16; 3 = 1/32.
- **Modulation:** 1 = QPSK; 2 = 16QAM; 3 = 64QAM.
- **Code_Rate:** 0,4 = Reserved; 1 = 1/2; 2 = 3/4.
- **Medium_Access:** 0 = MAS1; 1 = MAS2; 2 = MAS3-BS2, 3 = MAS3-BS3.

Number_of_Timeouts

Number_of_Timeouts is an 8-bit unsigned integer that identifies the number of timeout codes and values included in the message.

- **Code:** Code is a 4-bit unsigned integer that identifies the timeout or group of timeouts (according to table 43, table 44 and table 76) for which the following value is given.
- **Value:** Value is a 4-bit unsigned integer that gives the value for the timeout or group of timeouts identified by the preceding code according to table 43, table 44 and table 76.

8.4.9.8 <MAC> Link Management Response Message (Upstream contention or reserved)

The <MAC> **Link Management Response Message** is sent by the NIU to the INA to indicate the reception and the completion of processing of the previously sent singlecast Configuration Message, Reprovision Message or singlecast Transmission Control Message. The <MAC> **Link Management Response Message** is not sent in the following two cases:

- In response to a broadcast <MAC> Configuration Message or a broadcast <MAC> Transmission_Control Message.
- After reception of a <MAC> Transmission Control Message with Start bit set whilst in the ERROR_STOPPED state, see annex E.

The format of the message is shown in table 70.

Table 70: Link Management Response Message structure

Link_Management_Response_Message(){	Bits	Bytes	Bit Number/Description
Link_Management_Msg_Number	16	2	
}			

Link Management Message Number:

Link_Management_Msg_Number is a 16-bit unsigned integer representing the previously received Reprovision or Transmission Control Message. The valid values for Link_Management_Msg_Number are shown in table 71.

Table 71: Link Management Message Number

Message Name	Link_Management_Msg_Number
Transmission Control Message	Transmission Control Message Type Value
Reprovision Message	Reprovision Message Type Value
Configuration Message	Configuration Message Type Value

8.4.9.9 <MAC> Status Request Message (Downstream Singlecast)

The <MAC> **Status Request Message** is sent by the INA to the NIU to retrieve information about the NIU's health, connection information and error states. The INA can request the address parameters, error information, connection parameters or physical layer parameters from the NIU. The INA can only request one parameter type at a time to a particular NIU.

A detailed description of the status request process, including state diagrams and time outs, is given in annex E.

Table 72: Status Request Message structure

Status_Request(){	Bits	Bytes	Bit Number/Description
Status_Control_Field		1	
Status_Type	8		0..7:{enum type}
}			

Status Control Field:

Status_Type is an 8-bit enumerated type that indicates the status information the NIU shall return

```
enum Status_Type
{Address_Params, Error_Params, Connection_Params, Physical_Layer_Params,
Channel_Params, reserved 5..255};
```

8.4.9.10 <MAC> Status Response Message (Upstream Contention or reserved)

The <MAC> **Status Response Message** is sent by the NIU in response to the <MAC> **Status Request Message** issued by the INA. The contents of the information provided in this message vary depending on the request made by the INA and the state of the NIU. The message shall be split into separate messages if the resulting length of the message exceeds the slot payload, even if fragmentation of MAC messages is supported.

Table 73: Status Response Message Structure

Status_Response(){	Bits	Bytes	Bit Number/Description
NIU_Status		1	
Reserved	5		7..3
Network_Address_Registered	1		2
Connection_Established	1		1
Calibration_Operation_Complete	1		0
Response_Fields_Included		1	
Reserved	3		7..5
Channel_Params_Included	1		4:{no,yes}
Address_Params_Included	1		3:{no,yes}
Error_Information_Included	1		2:{no,yes}
Connection_Params_Included	1		1:{no,yes}
Physical_Layer_Params_Included	1		0:{no,yes}
<i>if (Response_Fields_Included and=</i> <i>Address_Params_Included){</i>			
MAC_Address	(48)	(6)	
<i>}</i>			
<i>if (Response_Fields_Included and=</i> <i>Error_Information_Included){</i>			
Number_Error_Codes_Included	(8)	(1)	
<i>for(i=0;i<Number_Error_Codes_Included;</i> <i>i++){</i>			
Error_Parameter_Code	(8)	(1)	
Error_Parameter_Value	(16)	(2)	
<i>}</i>			
<i>}</i>			
<i>if (Response_Fields_Included and=</i> <i>Connection_Params_Included) {</i>			
Number_of_Connections	(8)	(1)	
<i>for(i=0;i<Number_of_Connections;i++){</i>			
Connection_ID	(32)	(4)	
<i>}</i>			
<i>}</i>			
<i>if (Response_Fields_Included and=</i> <i>Physical_Layer_Params_Included) {</i>			
Power_Control_Setting	(8)	(1)	
SNR_Estimated	(8)	(1)	

Status_Response(){	Bits	Bytes	Bit Number/Description
Power_Level_Estimated	(8)	(1)	
}			
<i>if (Response_Fields_Included and= Channel_Params_Included) {</i>			
Upstream_Channel_Id	(8)	(1)	
Downstream_Frequency	(32)	(4)	
}			
}			

NIU Status:

NIU_Status is a 32-bit unsigned integer that indicates the current state of the NIU.

NIU_Status	NIU Status Code
Calibration_Operation_Complete	0x01
Connection_Established	0x02
Network_Address_Registered (reserved)	0x04

The state Calibration_Operation_Complete is reached after an Initialization Complete Message with status zero. The Connection_Established state indicates that the NIU has received a Connect Message indicating a connection that has not been released yet.

Response Fields Included:

Response_Fields_Included is an 8-bit unsigned integer that indicates what parameters are contained in the upstream status response.

MAC Address:

MAC_Address is a 6-byte address assigned to the NIU.

Number of Error Codes Included:

Number_Error_Codes_Included is an 8-bit unsigned integer that indicates the number of error codes contained in the response.

Error Parameter Code:

Error_Parameter_Code is an 8-bit unsigned integer representing the type of error reported by the NIU. Error_Parameter_Codes not supported by the NIU are not sent.

Table 74: Error Parameter Code

Error Parameter Code Name	Error Parameter Code
Reserved	0x00
Reserved	0x01
Reed_Solomon_Error_Count	0x02
Reserved	0x03
Reserved	0x04
Reserved	0x05
Reed_Solomon_Errors_Correctable	0x06
Reed_Solomon_Errors_Non_Correctable	0x07
Super_Frame_Count	0x08

Where:

- **Reed_Solomon_Error_Count** refers the number of errors as corrected by the Reed Solomon decoder.
- **Reed_Solomon_Errors_Correctable** refers to MPEG frames received with correctable Reed Solomon Errors.

- **Reed_Solomon_Errors_Non_Correctable** refers to MPEG frames received with non-correctable Reed Solomon Errors.
- **Super_Frame_Count** refers to the total number of super frames over which these statistics have been collected.

Error Parameter Value:

Error_Parameter_Value is a 16-bit unsigned integer representing error counts detected by the NIU. These values are set to 0 after they are transmitted to the INA. If the counter reaches its maximum value, it stops counting. The counter resumes counting after it is set to 0.

Number of Connections:

Number_of_Connections is an 8-bit unsigned integer that indicates the number of connections that are specified in the response. Specifically, if the number of connections is too large to have a MAC message with less than 40 bytes, it is possible to send separate messages with only the number of connections indicated in each message.

Connection_ID:

Connection_ID is a 32-bit unsigned integer representing the global connection Identifier used by the NIU for this connection.

Power Control Setting:

Power_Control_Setting is an 8-bit unsigned integer representing the actual power used by the NIU/RCTT for upstream transmission. A value of zero represents -50 dBm. Each increment of this value is in steps of 3 dBm.

SNR_Estimated:

SNR_Estimated is an 8-bit unsigned integer specifying the NIU estimated signal to noise ratio of the downstream carrying MAC messages. The unit is 0,2 dB. If the NIU is not able to estimate the value, the value zero (0) is used.

Power_Level_Estimated:

Power_Level_Estimated is an 8-bit unsigned integer specifying the NIU estimated power level of the downstream carrying MAC messages. The unit is dB μ V. If the NIU is not able to estimate the value, the value zero (0) is used.

Upstream_Channel_ID:

Upstream_Channel_ID is an 8-bit unsigned integer representing the channel ID assigned to the connections.

Downstream Frequency:

Downstream_Frequency is a 32-bit unsigned integer representing the frequency where the connection resides. The unit of measure is in Hz.

8.4.9.11 <MAC> US_Contention_Optimized_Transmission_Window_Message

Reserved for future use.

US_Contention_Optimized_Transmission_Window_Message () {	Bits	Bytes	Bit Number/Description
}			

8.5 Security (optional)

The security solution consists of two separate sub-systems:

- A new set of MAC messages used for authentication and key-agreement between INA and NIU. These messages are used for key negotiation during connection setup as well as for on-the-fly update of keys (see clause 8.5.7).
- On-the-fly encryption and decryption of payload data streams passed between INA and NIU.

When a connection is being setup, before payload data is transferred, one of three new request/response MAC message-pairs is used to generate a session key specific to the payload stream associated with the connection.

The session key is a shared secret between the INA and the NIU: even if every MAC message is intercepted, the cryptographic properties of the protocol ensure that an eavesdropper cannot determine the session key value.

This is achieved by using a public-key protocol, which requires no up-front shared secret, or a simpler protocol based on a long-term shared secret between INA and NIU called a cookie. The cookie is 160 bits long. It is also used for authenticating the NIU to the INA during connection-setup.

Each NIU will store its own cookie in non-volatile storage, whereas the INA will maintain a database of the cookie values of the NIUs on its network. Cookie values will be updated occasionally as dictated by security policy, but they are less vulnerable than session keys: a successful brute-force attack on a session key reveals nothing about the cookie value, nor any other session key.

The new MAC messages also implement a defence against clones: a NIUs that is a physical copy of an existing NIU and attempts to operate on the network under the cloned identity (when the cloned NIU itself is not registered on the network). The anti-cloning measure is a simple non-volatile 8-bit counter that is incremented synchronously at the INA and NIU over time: if a clone NIU engages in traffic with the INA, this will be detected the next time the cloned NIU connects because the counter value will be out of synchronization.

If the clone attempts to operate concurrently with the cloned unit, there will be an immediate breakdown of functionality for both units, due to confusion within the MAC protocol. This amounts to a denial-of-service attack, and the INA should be prepared for this kind of protocol failure.

Used mathematical operators and symbols in this clause:

\times	multiplication
\wedge	power
\sim	concatenation
mod	modulo division
(unsigned char)x	ANSI C cast operator: converts value \times to unsigned char
""	empty string (zero length)
nonce1	random string (INA)
nonce2	random string (NIU)

8.5.1 Cryptographic primitives

The key exchange protocols and data stream encryption is based on a set of well-established primitive cryptographic functions. The functions and their associated key sizes can be changed in the future, in case crypt-analytic or brute-force attacks become a realistic threat.

The specific set of functions and key sizes are negotiated between INA and NIU at sign-on time. The functions supported at the present time are Diffie-Hellman, HMAC-SHA1, and DES. Check current cryptographic literature for any updates regarding their security and use.

The following clauses give a brief overview of the cryptographic primitives, and details on how they are used in the protocol. Later clauses describe the exact field layout of the new MAC messages.

The protocol parameters are described in terms of byte strings, where concatenation is denoted by the \sim operator. Integer quantities are represented as base-256 byte strings. Big-endian byte-ordering is used, that is, the most significant byte comes first. If necessary to reach a fixed length, the string is padded with zeros at the most significant end.

8.5.1.1 Public key exchange

A public key exchange primitive is used to allow the INA and NIU to agree on a secret, although communicating in public. The Diffie-Hellman scheme is based on unsigned integer arithmetic and works as follows (\wedge denotes exponentiation):

The INA chooses two public values, a large prime number m , and a (small) number g , which is a generator modulo m (that is, $g^a \bmod m$ will generate all number from 0 to $m-1$ for varying a). The INA also chooses a secret number $x < m$, and sends the following three values to the NIU: m , g , $\times = g^x \bmod m$.

The NIU chooses a secret value $y < m$, and responds to the INA with the value $Y = g^y \bmod m$.

The NIU now calculates $s = X^y \bmod m = (g^x)^y \bmod m = g^{(x \times y)} \bmod m$, whereas the INA calculates $Y^x \bmod m = (g^y)^x \bmod m = g^{(y \times x)} = s$, so the INA and NIU now agree on the value s .

The value of s is a secret shared between INA and NIU. To determine its value from the publicly communicated values m , g , X , and Y , an eavesdropper shall determine x or y by solving an equation of the form $Z = g^z \bmod m$ for unknown z . This is known as the discreet logarithm problem and is computationally infeasible with current algorithms for sufficiently large values of m .

The parameter size supported is 512 bits for the prime number m , and hence also for the remaining values since all arithmetic is modulo m .

In the applicable MAC messages, the unsigned integer quantities m , g , X , and Y are encoded into fixed-size fields (64 bytes, 96 bytes, or 128 bytes) using big-endian byte-ordering.

8.5.1.2 Hashing

The protocol makes use of a keyed hash function that computes secure checksums which can only be verified with the possession of a secret key. The function has the one-way property, meaning that it is computationally infeasible to find an input value that maps to a given output value.

The hash function is also used to generate derived secret material based on a master secret. Because of the one-way property, the master secret is protected even if the derived secret is discovered.

In generic terms, the keyed hash function takes two byte strings as input, the *key* and a *data* string, and produces another string of bytes, the *digest*:

$$\text{digest} = H(\text{key}, \text{data})$$

The H function shall accept key and data parameters of any size, whereas the protocol is designed to accept digests of any size.

The specification currently supports the HMAC-SHA1 function defined in IETF RFC 2104 [4]. It produces a 20-byte digest.

8.5.1.3 Encryption

Payload data is encrypted and decrypted using a symmetric-key block cipher, which is used in Cipher Block Chaining (CBC) mode with special handling of any final odd-size block.

In generic terms, the encryption and decryption functions take two byte strings as input, the key and a data block, and produce as output another data block of the same length:

$$\text{ciphertext} = E(\text{key}, \text{plaintext})$$

$$D(\text{key}, \text{ciphertext}) = \text{plaintext}$$

The key length and block length is given by the chosen cipher, and the payload stream processing logic will apply it as appropriate to data units of various sizes.

The specification currently supports the DES algorithm, which has a block size is 8 bytes, and various options for key length based on an 8-byte raw key block (see clause 8.5.5).

8.5.1.4 Pseudo-random numbers

The protocols used for generating secret values depend on the availability of a pseudo-random, that is, practically unpredictable, endless string of bytes. This will typically be produced with a Pseudo-Random Number Generator, PRNG, algorithm.

The random bytes are used to generate the secret Diffie-Hellman values, x and y , and for nonce values used during key exchange. The unpredictable nature of the random input ensures that different secret values are produced each time, and also prevents replay of old intercepted messages.

This specification does not require any particular algorithm, only that the INA and NIU each choose one that is well established and cryptographically analysed.

The hardest aspect of using a PRNG is to initialize it with an unpredictable seed value. The seed should contain multiple high-granularity device-dependent time-samples, samplings of cable line noise, as well as any other available pseudo-random material, like file allocation tables, etc. These random source values are then hashed together to squeeze out the entropy for the seed value.

8.5.2 Main Key Exchange, MKE

Main Key Exchange uses Diffie-Hellman to develop a shared secret between the INA and NIU, which is independent of the cookie value. Furthermore, it uses the cookie value to authenticate the NIU to the INA. It optionally uses the newly developed shared secret to update the cookie value. Finally, it derives a shared secret key used for the security context that is used to process payload stream data.

The exchange is initiated by the INA sending a message containing the Diffie-Hellman values, m , g , X , and a random nonce string, $nonce1$. The NIU responds with a message containing its Diffie-Hellman value, Y , a random nonce string, $nonce2$, and an authentication string, $auth$.

The INA and NIU each use the same formula to calculate the authentication string (\sim means concatenation):

$$auth = H (cookie, nonce1 \sim nonce2)$$

which is communicated by the NIU and checked by the INA. This proves the identity of the NIU, since it requires knowledge of the cookie to calculate the correct value of $auth$.

The NIU and INA each use the Diffie-Hellman values (see clause 8.5.1.1) to arrive at the same secret value, s :

$$s = g^{(x \times y)} \text{ mod } m.$$

This unsigned integer value is encoded as a byte string, of length specified by the Diffie-Hellman parameter size, using big-endian byte ordering. It is then used to calculate a temporary shared secret string, $temp$:

$$temp = H (encode (s), nonce2 \sim nonce1).$$

If the cookie is to be updated, the new value is computed in sections for $n = 1, 2, \dots$:

$$newcookie(n) = H (temp \sim (unsigned\ char)1 \sim (unsigned\ char)n, "")$$

where $(unsigned\ char)$ is the cast operator of the C programming language, and $""$ is the empty string (zero length). These string values are computed and concatenated until the total length matches or exceeds the length of the cookie. The cookie is then obtained by taking the first 20 bytes out of the concatenated sections, starting from the beginning.

The session key used for payload stream encryption is likewise computed in sections:

$$key(n) = H (temp \sim (unsigned\ char)2 \sim (unsigned\ char)n, "")$$

where, again, a sufficient number of sections are calculated to produce enough bytes to cover the length of the key. The session key is obtained, in the same manner as the cookie" by taking the required number of bytes out of the concatenated sections, starting from the beginning.

8.5.3 Quick Key Exchange, QKE

Quick Key Exchange uses the existing cookie value to authenticate the NIU to the INA, and then derive a shared secret key used for the security context that is used to process payload stream data.

The exchange is initiated by the INA sending a message containing a random nonce string, $nonce1$. The NIU responds with a message containing a random nonce string, $nonce2$, and an authentication value, $auth$.

The value of $auth$ is calculated in the same way as for Main Key Exchange, and is likewise used to verify the identity of the NIU (see clause 8.5.2).

The NIU and INA then each calculate a temporary shared secret string, $temp$:

$$temp = H (cookie \sim (unsigned\ char)3, nonce2 \sim nonce1)$$

This value is used to produce the payload encryption key in the same way as for Main Key Exchange (see clause 8.5.2).

8.5.4 Explicit Key Exchange, EKE

Explicit Key Exchange is used by the INA to deliver a pre-determined session key to the NIU. The session key is encrypted under a temporary key derived from the cookie value, and is used for the security context that is used to process payload stream data.

The delivery is performed by the INA sending a message containing a random nonce string, *nonce1*, and a byte string value, *encryptedkey*, which has the same length as a key used for payload encryption. The NIU responds with a message containing a random nonce string, *nonce2*, and an authentication value, *auth*.

The value of *auth* is calculated in the same way as for Main Key Exchange, and is likewise used to verify the identity of the NIU (see clause 8.5.2).

Both the INA and NIU calculate a temporary shared secret string, *temp*:

$$temp = H (cookie \sim (unsigned\ char)^4, nonce1)$$

which is used to produce sections of a temporary key, in the same way as for Main Key Exchange (see clause 8.5.2). The INA uses these temporary key string sections to XOR with the session key to obtain the *encryptedkey* value, and the NIU performs a second XOR operation to decrypt the session key value.

For normal DES, 8 bytes of raw key data are delivered, which are used to derive the actual key with the appropriate number of effective bits, as described below (see clause 8.5.5).

8.5.5 Key derivation

The actual key value used for processing payload data is derived from the *key* sections developed during key exchange. For DES, 8 bytes of raw key data is required, so a single 20-byte section, *key(1)*, computed by HMAC-SHA1 is sufficient.

In each byte, the least significant bit is not used (it can be used as an odd-parity bit of the remaining 7 bits), bringing the effective key size down to 56 bits.

Furthermore, when used in 40-bit mode, the two most significant bits of each byte in the key are zeroed.

8.5.6 Data stream processing

Security can be applied to various payload data streams selectively. The elementary unit is called a security context, which contains two session keys used for encrypting and decrypting a stream of payload data. Only one of the keys is used to process any particular payload unit. Each key can be used for processing both upstream and downstream payload data.

Having two keys allows negotiation of a new key to take place while payload data is processed using the old one, and then do an immediate switchover once the new key is agreed upon, without interrupting payload traffic. The INA initiates the key exchanges, and can start using a session key for downstream traffic encryption once the key exchange is complete. For upstream traffic encryption, the NIU should use whichever key was used by the INA in the most recent encrypted payload unit.

8.5.6.1 Payload streams

A payload stream is identified by either of:

- a 24-bit (UNI) ATM virtual circuit VPI/VCI: this is used for upstream payload data. The ATM circuit can be one-to-one, or one end-point of a multi-cast circuit;
- a 48-bit MAC-address: this is used for DVB Multiprotocol Encapsulation downstream payload data. The MAC-address can be the physical address of the RCTT or a pseudo address used for MAC-address based multi-casting.

When a payload stream is secured, the NIU and the INA will have matching security contexts, which are used to encrypt/decrypt both upstream and downstream traffic. For unsecured payload streams there is no security context, and payload data is not encrypted.

To support encrypted multi-cast traffic, the same security context will be created for each member using EKE (see clause 8.5.4), so that each NIU can decrypt the common payload data stream.

8.5.6.2 Data encryption

Within a payload data stream, data is carried in individual units at the various protocol layers. Encryption is applied at the lowest layer possible, consistent with the payload stream:

- ATM-based payload streams: the unit of encryption is a single ATM cell. The 48-byte cell payload is encrypted using the security context implied by the associated connection.
- Encryption is transparent to higher-level protocol layers, which see only unencrypted cell payloads.
- DVB Multiprotocol Encapsulation payload streams: the unit of encryption is a single DVB Multiprotocol Encapsulation section. The datagram_data_bytes (between the MAC-address and the CRC/checksum) are encrypted using the security context implied by the associated connection. The DVB Multiprotocol Encapsulation payload to be encrypted will be adjusted to have a length of $n \times 8$ bytes (n is an integer) by adding an appropriate amount (0 .. 7 bytes) of stuffing bytes before the CRC/checksum according to [6]. The CRC/checksum is calculated on the encrypted datagram bytes, while higher-level protocol layers see only unencrypted datagrams.

8.5.6.3 Encryption flags

There are flags in the header of each encryption unit specifying which of the two sessions keys of the security context is used.

The receiver will use the security context of the payload stream to see if decryption shall be done.

- ATM cells: the least significant two bits of the Generic Flow Control, GFC, field of the cell header are used:
 - 00: not encrypted;
 - 01: reserved;
 - 10: encrypted using session key 0;
 - 11: encrypted using session key 1.

The most significant two bits of the GFC field are reserved for future use, and shall be set to 00.

- DVB Multiprotocol Encapsulation sections, according to EN 301 192 [5]: the 2-bit payload_scrambling_control field in the section header is used:
 - 00: not encrypted;
 - 01: reserved;
 - 10: encrypted using session key 0;
 - 11: encrypted using session key 1.

The 2-bit address_scrambling_control field in the section header is 00 all the time (the address is not scrambled).

8.5.6.4 Chaining and initialization vector

Within encryption units, the block encryption algorithm is used in Cipher Block Chaining mode, CBC: the first plain-text block is XOR'ed with an initialization vector (IV), and subsequent blocks are XOR'ed with the previous cipher-text block, before the block is encrypted. Decryption is opposite: each cipher-text block is first decrypted and then XOR'ed with the previous chaining value.

The value of the IV for a given encryption unit is zero.

8.5.7 Security Establishment

Security issues are handled in the following situations:

- When a NIU registers on the network it will do an initial handshake with the INA to establish the level of security support, in particular the cryptographic algorithms and key sizes to be used subsequently.

The handshake consists of <MAC> **Security Sign-On Message** and <MAC> **Security Sign-On Response Message** (see clauses 8.5.9.1 and 8.5.9.2) which are exchanged immediately prior to the <MAC> **Initialization Complete Message**.

A failure during this stage of the protocol causes the INA to revert to non-secure interaction with the NIU.

- The security context of a secured payload stream is established when the underlying MAC connection is created, before any stream data is transmitted. One session key is agreed, and the cookie and/or clone counter values may be updated as part of the exchange.

The key exchange consists of <MAC> **Main/Quick/Explicit Key Exchange Message** and <MAC> **Main/Quick/Explicit Key Exchange Response Message** (see clauses 8.5.9.3 to 8.5.9.8) which are exchanged immediately prior to the <MAC> **Connect Confirm Message**.

A failure during this stage of the protocol causes the connection-setup operation to fail.

- After a connection is in use, each session key of the security context of the payload stream can be updated on-the-fly, that is, without re-establishing the underlying connection, and without interrupting payload data traffic. The cookie and/or clone counter values cannot be updated as part of the exchange.

A new session key is negotiated using the same MAC messages used during connection-setup. There is no <MAC> **Connect Confirm Message**.

A failure during this stage of the protocol causes the connection to be dropped.

While a session key of the security context is being updated for a particular connection, payload stream data traffic should be encrypted using the other session key or not at all. Once the key exchange is complete, the INA can start using it for subsequent downstream traffic, thereby directing the NIU to use it for upstream traffic.

All three variants of key exchange messages authenticate the NIU based on the existing cookie value. They also perform the clone detection counter check, and optionally increment the clone counter. Only MKE can update the cookie.

The security MAC message flow is naturally serialized within the context of the particular connection that is being setup. But, in as far as multiple connections are being established concurrently, there can also be multiple concurrent key exchanges whose messages are interleaved. The NIU is free to complete outstanding key exchanges on separate connections in any order it chooses.

8.5.8 Persistent state variables

To facilitate authentication, key exchange, and clone detection, the NIU has a set of state variables whose values are retained across registrations and power cycles.

Table 75: Persistent NIU variables

Name	Function	Size
Cookie	authentication cookie	160 bits
Cookie_SN	cookie sequence number	1 bit
Clone_Counter	clone detection counter	8 bits
Clone_Counter_SN	clone counter sequence number	1 bit

The sequence numbers are used to ensure that the INA and NIU can stay synchronized even in case the NIU drops off the net in the middle of a protocol exchange.

8.5.8.1 Guaranteed delivery

Within the setup protocol for a MAC connection, the INA will ensure that a protocol exchange is complete before proceeding. If it does not receive a response MAC message within a given time-interval, it will re-transmit the original message unchanged. The NIU will do likewise in situations where it requires a response. If the number of re-transmissions exceeds three, the protocol fails.

Due to race conditions, superfluous re-transmissions may be generated by both INA and NIU. They shall discard such messages after the first message has in fact been received.

If the NIU is not ready to respond within the specified time-out, it can send **<MAC> Wait Messages** (see clause 8.5.9.9) to extend the time it has available to generate a proper response. Upon receiving the wait message, the INA will restart its timer and reset the retry count.

The protocol time-out values can be set by the **<MAC> Default Configuration Message**, otherwise the following default values apply:

Table 76: Protocol time-out values

Code	Protocol stage	Default Value
0xD	Security Sign-On	$90 + 2 \times \text{Time_slot_duration}$
0xE	Main Key Exchange	$600 + 2 \times \text{Time_slot_duration}$
0xF	Quick Key Exchange Explicit Key Exchange	$300 + 2 \times \text{Time_slot_duration}$

The Unit for the timeouts is milliseconds.

8.5.9 Security MAC Messages

8.5.9.1 <MAC>Security Sign-On (Single-cast Downstream)

As part of the registration process when a NIU attaches to the network, the INA and NIU will negotiate the specific set of cryptographic algorithms and parameters used in the key exchange protocols and for payload encryption.

The selections are global, and apply to all subsequent security exchanges for as long as the NIU is registered on the network.

The selections affect the layout of the subsequent key exchange messages, since they have fields that vary in size according to the choice of algorithms and parameters.

The INA indicates which algorithms and parameters it supports by setting the appropriate bits in the **<MAC>Security Sign-On Message**. There are four classes of algorithms, and the INA will set one or more bits in each of the four fields to indicate which specific choices it supports.

Table 77: Security Sign-On message structure

Security_Sign-On () {	Bits	Bytes	Bit Number/Description	Parameter bytes
Public_Key_Al		1	Public key algorithm choices:	P_{pka} :
PKA_Reserved	7		7..1: Reserved, shall be 0	64
PKA_DH_512	1		0:(yes/no) Diffie-Hellman, 512 bits	
Hash_Al		1	Hash algorithm choices:	P_{ha} :
HA_Reserved	7		7..1: Reserved, shall be 0	20
HA_HMACSHA1	1		0:(yes/no) HMAC-SHA1	
Encryption_Al		1	Encryption algorithm choices:	P_{ea} :
EA_Reserved	6		7..2: Reserved, shall be 0	8
EA_DES_56	1		1:(yes/no) DES, 56 bit key	
EA_DES_40	1		0:(yes/no) DES, 40 bit key	
Nonce_Size		1	Nonce size choices:	P_{ns} :
NS_Reserved	7		7..1: Reserved, shall be 0	8
NS_64	1		0: (yes/no) 8 random bytes	
Reserved	32	4	Reserved for future use, shall be 0	
}				

If the security option is supported, the minimum subset to support is PKA_DH_512, HA_HMACSHA1, EA_DES_40, and NS_64.

EA_DES_56 is optional.

8.5.9.2 <MAC>Security Sign-On Response (Upstream)

In its security sign-on response, the NIU indicates which specific algorithms and parameters to use. It does so by choosing one of the suggestions offered by the INA within each of the four classes.

The fields of the response message have the same definition as the message from the INA, except that exactly one bit will be set in each field.

If the NIU is unable to support any of the suggested algorithms for any class, it shall return an all-zero field value, and the INA will revert to non-secure communication or re-issue the <MAC>Security Sign-On Message with different choices.

Table 78: Security Sign-On Response message structure

Security_Sign-On_Response() {	Bits	Bytes	Bit Number/Description	Parameter bytes
Public_Key_Al		1	Public key algorithm choices:	P_{pka} :
PKA_Reserved	7		7..1: Reserved, shall be 0	64
PKA_DH_512	1		0:(yes/no) Diffie-Hellman, 512 bits	
Hash_Al		1	Hash algorithm choices:	P_{ha} :
HA_Reserved	7		7..1: Reserved, shall be 0	20
HA_HMACSHA1	1		0:(yes/no) HMAC-SHA1	
Encryption_Al		1	Encryption algorithm choices:	P_{ea} :
EA_Reserved	6		7..2: Reserved, shall be 0	8
EA_DES_56	1		1:(yes/no) DES, 56 bit key	
EA_DES_40	1		0:(yes/no) DES, 40 bit key	
Nonce_Size		1	Nonce size choices:	P_{ns} :
NS_Reserved	7		7..1: Reserved, shall be 0	8
NS_64	1		0: (yes/no) 8 random bytes	
Reserved	32	4	Reserved for future use, shall be 0	
}				

8.5.9.3 <MAC>Main Key Exchange (Single-cast Downstream)

The Main Key Exchange message is used to start a cookie-independent key exchange with the NIU, and also instructs the NIU whether to update its cookie value and clone counter value.

Table 79: Main Key Exchange message structure

Main_Key_Exchange () {	Bits	Bytes	Bit Number/Description
Connection_ID	32	4	MAC connection identifier
Flags	8	1	
Reserved	4		7..4: shall be 0
FL_Initializing	1		3: (yes/no) first ever key exchange
FL_Update_Cookie	1		2: (yes/no) make new cookie value
FL_Update_Counter	1		1: (yes/no) increment clone counter
FL_Session_Key	1		0: select session key 0 or 1
Reserved	8	1	Reserved for future use, shall be 0
Nonce		P _{ns}	Random string nonce1
DH_Modulus		P _{pka}	Diffie-Hellman modulus m
DH_Generator		P _{pka}	Diffie-Hellman generator g
DH_Public_X		P _{pka}	Diffie-Hellman public value X
}			

The FL_Session_Key bit specifies which session key of the security context to update.

If the FL_Update_Counter bit is set, it instructs the NIU to increment its clone detection counter.

If the FL_Update_Cookie bit is set, it instructs the NIU to generate a new cookie value to be used for future authentications and key exchanges, and to reset the clone detection counter to zero.

Any updates to the cookie, clone counter, or their associated sequence number bits do not take effect until the following <MAC> Connect Confirm Message is received by the NIU.

If the FL_Initializing bit is set, it tells the NIU that the Authenticator field in the response will be ignored. The sizes of the multi-byte fields are determined by the parameters of the algorithms selected during security sign-on (see clause 8.5.9.1).

The INA will use its own private Diffie-Hellman value, x , together with the fields of the response message from the NIU to derive the new session key value, as well as any new value for the cookie (see clause 8.5.2).

8.5.9.4 <MAC>Main Key Exchange Response (Upstream)

The Main Key Exchange Response message authenticates the NIU and completes the cookie-independent key exchange with the INA. It also contains the current value of the clone detection counter.

Table 80: Main Key Exchange Response message structure

Main_Key_Exchange_Re-sponse () {	Bits	Bytes	Bit Number/Description
Connection_ID	32	4	MAC connection identifier
Flags	8	1	
Reserved	6		7..2: shall be 0
FL_Cookie_SN	1		1: cookie sequence number
FL_Counter_SN	1		0: clone counter sequence number
Clone_Counter	8	1	Current clone counter value
Nonce		P _{ns}	Random string nonce2
Authenticator		P _{ha}	Authentication value auth
DH_Public_Y		P _{pka}	Diffie-Hellman public value Y
}			

The `FL_Counter_SN` bit is the current sequence number of the clone detection counter. The `Clone_Counter` field is the current value of the counter. A clone collision has been detected if the INA finds a mis-match from the expected value.

The `FL_Cookie_SN` bit is the sequence number of the cookie used for authentication.

If the `FL_Update_Cookie` bit was set by the INA, the NIU will generate a new cookie value and complement the cookie sequence number bit. It will also reset the clone counter value to zero and clear the clone counter sequence number bit.

If the `FL_Update_Counter` bit was set by the INA, the NIU will increment the value of the clone counter (modulo 256) and complement the clone counter sequence number bit.

Any updates to the cookie, clone counter, or their associated sequence number bits do not take effect, and shall not be committed to non-volatile storage, until the following **<MAC> Connect Confirm Message** is received by the NIU.

The NIU uses its private Diffie-Hellman value, y , together with the message fields to derive the new session key value, as well as any new value for the cookie (see clause 8.5.2).

8.5.9.5 <MAC>Quick Key Exchange (Single-cast Downstream)

The Quick Key Exchange message is used to start a cookie-dependent key exchange with the NIU, and also instructs the NIU whether to update its clone counter value.

Table 81: Quick Key Exchange message structure

Quick_Key_Exchange () {	Bits	Bytes	Bit Number/Description
Connection_ID	32	4	MAC connection identifier
Flags	8	1	
Reserved	6		7..2: shall be 0
FL_Update_Counter	1		1: (yes/no) increment clone counter
FL_Session_Key	1		0: select session key 0 or 1
Reserved	8	1	Reserved for future use, shall be 0
Nonce		P_{ns}	Random string <i>nonce1</i>
}			

The `FL_Session_Key` bit specifies which session key of the security context to update.

If the `FL_Update_Counter` bit is set, it instructs the NIU to increment its clone detection counter.

The INA will use its knowledge of the cookie value together with the fields of the response message from the NIU to derive the session key value (see clause 8.5.3).

8.5.9.6 <MAC>Quick Key Exchange Response (Upstream)

The Quick Key Exchange Response message authenticates the NIU and completes the cookie-dependent key exchange with the INA. It also contains the current value of the clone detection counter.

Table 82: Quick Key Exchange Response message structure

Quick_Key_Exchange_Re-sponse () {	Bits	Bytes	Bit Number/Description
Connection_ID	32	4	MAC connection identifier
Flags	8	1	
Reserved	6		7..2: shall be 0
FL_Cookie_SN	1		1: cookie sequence number
FL_Counter_SN	1		0: clone counter sequence number
Clone_Counter	8	1	Current clone counter value
Nonce		P_{ns}	Random string <i>nonce2</i>
Authenticator		P_{ha}	Authentication value <i>auth</i>
}			

The `FL_Cookie_SN` bit is the sequence number of the cookie used for authentication.

The `FL_Counter_SN` bit is the current sequence number of the clone detection counter. The `Clone_Counter` field is the current value of the counter. A clone collision has been detected if the INA finds a mis-match from the expected value.

If the `FL_Update_Counter` bit was set by the INA, the NIU will increment the value of the clone counter (modulo 256) and complement the clone counter sequence number bit. The updated values do not take effect, and shall not be committed to non-volatile storage, until the following **<MAC> Connect Confirm Message** is received by the NIU.

The NIU uses the cookie value together with the message fields to derive the session key value (see clause 8.5.3).

8.5.9.7 <MAC>Explicit Key Exchange (Single-cast Downstream)

The Explicit Key Exchange message is used to securely deliver an existing session key value to the NIU, and also instructs the NIU whether to update its clone counter value.

Table 83: Explicit Key Exchange message structure

Explicit_Key_Exchange () {	Bits	Bytes	Bit Number/Description
Connection_ID	32	4	MAC connection identifier
Flags	8	1	
Reserved	6		7..2: shall be 0
FL_Update_Counter	1		1:(yes/no) increment clone counter
FL_Session_Key	1		0: select session key 0 or 1
Reserved	8	1	Reserved for future use, shall be 0
Nonce		P _{ns}	Random string nonce1
Encryptedkey		P _{ea}	Encrypted session key
}			

The `FL_Session_Key` bit specifies which session key of the security context to update.

If the `FL_Update_Counter` bit is set, it instructs the NIU to increment its clone detection counter.

The INA has used its knowledge of the cookie value to encrypt the session key value (see clause 8.5.4).

8.5.9.8 <MAC>Explicit Key Exchange Response (Upstream)

The Explicit Key Exchange Response message authenticates the NIU and acknowledges receipt of the delivered key. It also contains the current value of the clone detection counter.

Table 84: Explicit Key Exchange Response message structure

Explicit_Key_Exchange_Response () {	Bits	Bytes	Bit Number/Description
Connection_ID	32	4	MAC connection identifier
Flags	8	1	
Reserved	6		7..2: shall be 0
FL_Cookie_SN	1		1: cookie sequence number
FL_Counter_SN	1		0: clone counter sequence number
Clone_Counter	8	1	Current clone counter value
Nonce		P _{ns}	Random string nonce2
Authenticator		P _{ha}	Authentication value auth
}			

The `FL_Cookie_SN` bit is the sequence number of the cookie used for authentication and session key decryption. If the INA determines that it has used the wrong cookie for session key encryption it will re-issue the **<MAC> Explicit Key Exchange Message** using the old cookie value.

The `FL_Counter_SN` bit is the current sequence number of the clone detection counter. The `Clone_Counter` field is the current value of the counter. A clone collision has been detected if the INA finds a mis-match from the expected value.

If the `FL_Update_Counter` bit was set by the INA, the NIU will increment the value of the clone counter (modulo 256) and complement the clone counter sequence number bit. The updated values do not take effect, and shall not be committed to non-volatile storage, until the following `<MAC> Connect Confirm Message` is received by the NIU.

The NIU uses the cookie value together with the message fields to decrypt the session key value (see clause 8.5.4).

8.5.9.9 `<MAC>Wait (Upstream)`

The Wait message is used by the NIU to extend the time the INA waits for a reply to a given message. Upon receiving it, the INA will reset its time-out value and retry count (see clause 8.5.8.1).

Table 85: Wait message structure

<code>Wait () {</code>	Bits	Bytes	Bit Number/Description
<code>Connection_ID</code>	32	4	MAC connection identifier
<code>Message_Type</code>	8	1	Type of message from INA
<code>Reserved</code>	8	1	Reserved for future use, shall be 0
<code>}</code>			

The `Message_Type` field is the message type value of the message received from the INA being processed. If the message is specific to a connection, the `Connection_ID` field identifies which; otherwise this field is zero. The NIU indicates that it is currently unable to send a reply to the message.

8.6 MAC Primitives

In order to provide a common way to interface to the MAC functions, primitives are defined above the MAC Layer. These primitives are intended to cover both the Return Channel Terrestrial Terminal (RCTT) applications and the INA functions of the Head-End.

The MAC responsibility is mainly:

- The synchronization of the RCTT to the network (initial physical link set-up) and establishment of the initial Connection.
- The management of the subsequent Connections between the INA and the RCTT. (It gets the Connections allocated by the INA and insures also the functions relative to the various modes of communication, for example the acknowledgement of contention based transmissions or the reservation requests of bandwidth when needed.)
- The periodical Link Management functions that insure a correct physical link (for example the power level and time offset modifications, or the re-assignments of resources requested by the INA).

The interface between MAC and the upper layer has been implemented using primitives. They have been defined as usually in the OSI layer model architecture.

Prefix	Identifier of the layer that provides the service.
Core	Name of the primitive, it is relative to the action performed.
Suffix	Indication of the data direction.

The advantage of primitives is that they provide a clear and deterministic mean of exchange between layers. In addition, this method permits an easier adaptation work as the final products can be implemented with various physical links between the NIU and the upper entity.

The MAC primitives can be split into two sets:

- The MAC Control and Resource primitives cover the signalling and link management information exchange between the MAC layer and the management entity of the RCTT or the INA (clause 8.1).

- The MAC Data primitives cover the transport of data application payload between the MAC layer and upper layer entities (clause 8.2).

The primitives correspond to an event. They carry parameters. In order to facilitate their identification and by consequence their processing they are identified by a unique id.

The id (Primitive_id) is coded on 16 bits. The rules of numbering are:

b15 - b12 : Layer : 0 = MAC, 1 = DL (other values (2 to 0xF) are reserved)

b11 : Control/data : 1 the primitive is a control primitive, 0 the primitive is a data primitive

b10 - b0 : Primitive Nb : root value of the Primitive_id

The root value of the Primitive_id will be assigned starting from the value 1.

The primitives correspond to the definition of services that are deduced from the features of the MAC layer. But the various implementations of the present document will probably need more information exchanges based on new messages for manufacturers specificity. In order to allow the definition and usage of proprietary primitives, the values starting at 0x7FF and assigned on a decreasing scheme down to 0x400 can be used.

All parameters of the primitives are coded in the order they are listed, with the MSB first for each parameter. Unless otherwise noted, the type of the parameters is unsigned integer.

8.7 Control and Resource Primitives

8.7.1 On RCTT side

8.7.1.1 <Prim> MAC_ACTIVATION_REQ

Parameter	Format	Comment
Primitive_id	16	0x0801
DS_Channels_Nb	8	Number of channels to try
DS_Channels_List	56[Freq_Nb]	List of downstream channels to try (in Hz)

The channels list is the structure defined below:

Parameter	Format	Comment
DS_Frequency	32	Downstream frequency
Mode	2	Channel spacing
Code_Rate_High_P	3	Convolutif coding rate of the high priority stream
Code_Rate_Low_P	3	Convolutif coding rate of the low priority stream
Carrier Offset	4	Carrier offset
Hierarchy	4	Hierarchical Mode
Guard interval	3	Guard interval
Modulation	3	Modulation
FFT_Size	2	FFT_Size

The management entity asks the MAC layer to start the processing of network synchronization. It can provide the characteristics of Downstream Channel. The list of downstream channels is passed to accelerate the scanning. If no channel is mentioned (Channels_Nb = 0), the MAC layer will make a scan on the full set of downstream DVB-T frequencies.

After receiving this primitive, the MAC layer set-up the first downstream channel and starts the initial synchronization processing (Provisioning, Default Configuration, Ranging and Power Calibration, Init Complete).

If it is not successful, the process is re-started for each new downstream channel of the list.

If all given channels in the list fail, a full scan is done.

When the Init Complete message is correctly decoded, or when the full set of channels and the full set of implemented downstream characteristics has been tried without success, the primitive MAC_ACTIVATION_CNF is sent, specifying the success or the reason of the failure.

DS_Channels_Nb: Number of frequencies to try (next parameter).

DS_Channels_List: Table of downstream channels. including all characteristics of the carriers:

- DS_Frequency: downstream frequency in Hz.
- Mode: channel spacing: the values 0 to 2 mean 6 MHz, 7 MHz or 8 MHz wide channel.
- Code_Rate_High_P: Convolution coding rate of the high priority path: value 0 means that all the coding rates have to be tested. Values 1 to 5 mean the coding rate have the respective values 1/2, 2/3, 3/4, 5/6, 7/8.
- Code_Rate_Low_P: Convolution coding rate of the low priority path: value 0 means that all the coding rates have to be tested. Values 1 to 5 mean the coding rate have the respective values 1/2, 2/3, 3/4, 5/6, 7/8.
- Carrier Offset: Offset of the carrier compared to the downstream frequency: the value 0 means that all offset have to be tested. Values 1 to 3 mean respectively no offset, an offset of +167 kHz, and an offset of -167 kHz.
- Hierarchy: when the MSB of this nibble is set, the high priority channel is selected. If not, the low priority channel is selected. The three LSB indicate the hierarchical mode: value 0 means it has to be extracted from the TPS. The values 1 to 4 mean respectively there is no hierarchical mode, there is hierarchical mode with $\alpha = 1$ is selected, the $\alpha = 2$ is selected, the $\alpha = 4$ is selected.
- Guard interval: If this value is 0, all sizes of the guard interval have to be tested. Else, the values 1 to 4 indicate respectively values of the guard interval from 1/32, 1/16, 1/8 and 1/4.
- Modulation: If this value is 0, the modulation has to be extracted from the TPS. Else, the values 1 to 3 indicate QPSK, 16QAM and 64QAM modulation.
- FFT_Size: A value of 2 means the system is 8K mode, a value of 1 means the system is 2K mode, a value of 0 means both sizes have to be tested.

8.7.1.2 <Prim> MAC_ACTIVATION_CNF

Parameter	Format	Comment
Primitive_id	16	0x0802
Error_Code	32	Success or reason of the failure
DS_Channel	56	Downstream channel and its characteristics effectively used
US_Channel	56	Upstream channel and its characteristics used
INA_Capabilities	32	Capabilities of the INA

The US_Channel structure is the one below:

Parameter	Format	Comment
US_Channel_Frequency	32	First frequency of the upstream channel
Coding	1	Coding type: Reed Solomon or Turbo Code
Shaping	1	Shaping type: Nyquist or Rectangular
FFT Size	2	FFT size: 1k or 2k
Mode	2	Carrier spacing
Guard_Interval	2	Guard Interval
Modulation	2	Modulation
Code_Rate	2	Code Rate
Medium_Access	2	Medium Access Scheme
Frequency_Hopping	2	Frequency hopping

This primitive indicates the result of the MAC_ACTIVATION_REQ or the change of any of the listed parameters (for example due to reprovisioning).

Error_code: A value of 0 means the success of the previous Activation Request, any other value will be used to indicate the reason of the failure. The least significant 8 bits are a copy of the Status_Field of the <MAC> **Ranging and Power Calibration Message**. If no <MAC> **Ranging and Power Calibration Message** was received, these bits are zero.

DS_Channel: Value of the downstream channel where the MAC locked (see DS_Channel structure before). Meaningless if Error_Code \neq 0.

US_Channel: Upstream channel used. Meaningless if Error_code \neq 0. . The characteristics of the upstream channel are the following:

- **US_Channel_Frequency:** First frequency of the upstream channel.
- **Coding:** Defines the coding scheme: 0 = Reed Solomon; 1= Turbo Code.
- **Shaping:** Defines the pulse shaping, 0 = Nyquist; 1 = Rectangular.
- **FFT_Size:** Defines the system FFT size: 0 = 1K; 1 = 2K.
- **Mode:** Defines the working symbol rate. Values 0 to 2 mean carrier spacing CS1 to CS3.
- **Guard_Interval:** 0 = 1/4; 1 = 1/8; 2 = 1/16; 3 = 1/32.
- **Modulation:** 1 = QPSK; 2 = 16QAM; 3 = 64QAM.
- **Code_Rate:** 1 = 1/2; 2 = 3/4.
- **Medium_Access:** 0 = MAS1; 1 = MAS2; 2 = MAS3-BS2, 3 = MAS3-BS3.
- **Frequency Hopping:** 0 = no frequency hopping.

INA_Capabilities: A copy of the INA_Capabilities field of the <MAC> **Default Configuration Message** in order to inform the higher layers of the NIU whether the INA is capable of Resource Requests, different encapsulation types, security, ... Meaningless if Error_code \neq 0.

8.7.1.3 <Prim> MAC_CONNECT_IND

Parameter	Format	Comment
Primitive_id	16	0x0803
Connect_Id	32	Connection identifier
Res_Req_Id	8	If not null, correspond to the identifier of a previous Resource Request
US_Fixed_Bandwidth	32	Upstream capacity of the connection in Fixed rate mode
US_VP_VC_valid	8	Validity flag of the 2 next fields
US_VPI	8	VPI value to be used in upstream for this connection
US_VCI	16	VCI value to be used in upstream for this connection
PID_valid	8	Validity flag of the next field
PID	32	MPEG PID value of the connection
MAC_add_valid	8	Validity flag of the next field
MAC_add	48	MAC address of the connection
Encapsulation	8	Type of encapsulation for this connection
User_Port_valid	8	Validity flag of the next field
User_Port_ID	16	Low latency telephony port id
Add_Port_Type	8	Validity flag of the next 4 fields
Source_IP_add	32	IP address that will be used as source for this connection
Source_Port_nb	16	Port number that will be used for this connection
Dest_IP_add	32	IP address that will be used as destination for this connection
Dest_Port_nb	16	Port number that will be used for this connection

Parameter	Format	Comment
Ethernet_add_valid	8	Validity flag of the next 2 fields
Source_Eth_MAC_add	48	Identifies the Ethernet MAC address of the source of the Ethernet frames to be transported within this connection
Dest_Eth_MAC_add	48	Identifies the Ethernet MAC address of the destination of the Ethernet frames to be transported within this connection

This primitive indicates that the MAC layer has received a Connect Message from the INA. The connection is either:

- the Default Connection (Connect Message) sent by the INA just after the Initialization Complete message (first connection);
- a subsequent Connect message;
- an answer to a Resource Request previously sent by the RCTT (see Resource Request primitive);
- an indication of a change in the connection characteristics after reception of a Re provisioning message.

Connect_Id: Is the identifier of the connection.

Res_Req_Id: If equal to 0, the connection corresponds to a spontaneous Connect Message coming from the INA, if not null, is the id of the corresponding Resource Request.

US_Bandwidth: Gives the upstream transfer capacity in Fixed Rate mode (in slots/100ms). Zero if no fixed rate slots have been given by the INA.

US_VPI/US_VCI: VPI/VCI pair of the Upstream CBD, when this parameter is mentioned in the Connect Message (This parameter is provided for implementations that compose the AAL5 CPCS-PDU outside the MAC layer).

PID_valid: The PID in the next field is valid (0 means invalid parameter).

PID: The connection uses this PID. (This parameter is provided for implementations that insure data filtering outside the MAC layer).

MAC_add: Mac address can be provided for multicast. (This parameter is provided for implementations that insure section filtering outside the MAC layer).

Encapsulation: Type of encapsulation provided. Correspond to the same field in the Connect message (i.e. Direct_IP, Ethernet_Mac_Bridging, PPP).

User_Port_valid: validity flag of the next parameter (0 means invalid parameter).

User_Port_ID: Low latency Telephone port id.

Add_Port_Type: Bit field that specifies TCP/UDP Port number and IP address validity:

- **bit 0:** next IP address fields are valid;
- **bit 1:** next Port nb fields are valid and are TCP port;
- **bit 2:** next Port nb fields are valid and are UDP port;
- **bits 3 to 7:** Reserved (shall be set to 0).

Source_IP_ad: Source IP address attributed to this connection.

Source_Port_nb: TCP or UDP source port number attributed to this connection.

Dest_IP_ad: Destination IP address attributed to this connection.

Dest_Port_nb: TCP or UDP destination port number attributed to this connection.

Ethernet_add_valid: The two next fields containing Ethernet MAC addresses are valid (0 if not valid).

Source_Eth_MAC_ad: Source Ethernet MAC address attributed to this connection.

Dest_Eth_MAC_ad: Destination Ethernet MAC address attributed to this connection.

8.7.1.4 <Prim>MAC_RSV_ID_IND

Parameter	Format	Comment
Primitive_id	16	0x0804
Connect_Id	32	Connection identifier
Res_Req_Id	8	If not null, correspond to the identifier of a previous Resource Request

This primitive indicates to the upper layer that the connection can use Reservation mode from this time. It can be an answer to a previous Resource Request.

Connect_Id: Is the identifier of the connection.

Res_Req_Id: If equal to 0, the Reservation Id corresponds to a spontaneous Reservation ID Assignment message coming from the INA. If not null, it gives the Identifier of a previous resource request.

8.7.1.5 <Prim> MAC_RELEASE_IND

Parameter	Format	Comment
Primitive_id	16	0x0805
Connect_Id	32	Connection identifier
Res-Req_Id	8	If not null, correspond to the identifier of a previous Resource Request

The MAC layer indicates that it has received a Release message for this connection from the INA.

Connect_Id: Is the identifier of the connection.

Res_Req_Id: If equal to 0, the primitive corresponds to a spontaneous Release message coming from the INA. If not null, it gives the Identifier of a previous Resource Request from the upper layer requesting the release.

8.7.1.6 <Prim> MAC_RESOURCE_REQ

Parameter	Format	Comment
Primitive_id	16	0x0806
Connect_Id	32	Connection identifier
Resource_Type	8	Type of Resource requested
DS_Bandwidth	32	Downstream Bandwidth requested.. Not currently used.
DS_Jitter	16	Max. jitter in downstream requested. . Not currently used.
US_Bandwidth	32	Upstream transfer capability
Slot_distance	16	Distance between slots requested
Encapsulation	8	Type of encapsulation
User_Port_valid	8	Validity flag of the next field
User_Port_ID	16	Low latency telephony port id
Add_Port_Type	8	Validity flag of the next 4 fields
Source_IP_add	32	IP address that will be used as source for this connection
Source_Port_nb	16	Port number that will be used for this connection
Dest_IP_add	32	IP address that will be used as destination for this connection
Dest_Port_nb	16	Port number that will be used for this connection
Ethernet_add_valid	8	Validity flag of the next 2 fields
Source_Eth_MAC_add	48	Identifies the Ethernet MAC address of the source of the Ethernet frames to be transported within this connection
Dest_Eth_MAC_add	48	Identifies the Ethernet MAC address of the destination of the Ethernet frames to be transported within this connection

This primitive is used by the upper layer to ask for new resource. The MAC layer will send a Resource Request message to the INA.

As specified in the Resource Request message definition, upper layer can ask for a new connection, or a new upstream capacity (fixed rate bandwidth or a reservation id), or a connection release.

The final answer to this request shall be either a **MAC_Connect_Ind**, or a **MAC_RSV_ID_IND**, or a **MAC_RELEASE_IND** or a **MAC_RESOURCE_DENIED_IND**.

Connect_Id: Is the identifier of the connection, if it exists.

Resource_Type: Type of Resource requested:

- Bit field:
 - **bit 0** (0x01): a reservation id;
 - **bit 1** (0x02): a new connection in fixed rate mode;
 - **bit 2** (0x04): a new connection in cyclic fixed rate mode;
 - **bit 3** (0x08): upgrade bandwidth of an existing connection;
 - **bit 4** (0x10): release of an existing connection;
 - **bits 5 to 8**: reserved (shall be set to 0).

DS_Bandwidth: Downstream Bandwidth requested. Not currently used.

DS_Jitter: Max. jitter in downstream requested. Not currently used.

US_Bandwidth: Requested bandwidth for Fixed rate mode, unit is slots/s.

Slot_distance: When cyclic assignment is required, maximum distance between the slots, unit is in slots.

Encapsulation: Type of encapsulation requested. Corresponds to the same field in the Connect Message (i.e. Direct_IP, Ethernet_Mac_Bridging, PPP).

User_Port_valid: Validity flag of the next parameter (0 means invalid parameter).

User_Port_ID: Low latency Telephone port id.

Add_Port_Type: Bit field that specifies TCP/UDP Port number and IP address validity:

- **bit 0**: next IP address fields are valid;
- **bit 1**: next Port nb fields are valid and are TCP port;
- **bit 2**: next Port nb fields are valid and are UDP port;
- **bits 3 to 7**: Reserved (shall be set to 0).

Source_IP_add: Source IP address attributed to this connection.

Source_Port_nb: TCP or UDP source port number attributed to this connection.

Dest_IP_add: Destination IP address attributed to this connection.

Dest_Port_nb: TCP or UDP destination port number attributed to this connection.

Ethernet_add_valid: The two next fields of Ethernet MAC addresses are valid (0 if not valid).

Source_Eth_MAC_add: Source Ethernet MAC address attributed to this connection.

Dest_Eth_MAC_add: Destination Ethernet MAC address attributed to this connection.

8.7.1.7 <Prim>MAC_RESOURCE_CNF

Parameter	Format	Comment
Primitive_id	16	0x0807
Res_Req_Id	8	Identifier of the Resource Request

After reception of a **MAC_RESOURCE_REQ**, the MAC layer sends the Resource Request message to the INA; it creates an identifier and indicates it to the upper layer in order to identify the subsequent answer.

Res_Req_Id: The identifier of the last **MAC_RESOURCE_REQ** received by the MAC.

8.7.1.8 <Prim>MAC_RESOURCE_DENIED_IND

Parameter	Format	Comment
Primitive_id	16	0x0808
Res_Req_Id	8	Identifier of the Resource Request

This primitive indicates the reception of a Resource Denied Message; it is received after a Resource Request that has been refused by the INA.

Res_Req_Id: The identifier of a previous Resource Request that has been denied by the INA.

8.7.2 On INA side

8.7.2.1 <Prim> MAC_INA_RESOURCE_REQ

Parameter	Format	Comment
Primitive_ID	16	0x0811
Primitive_Request_ID	16	Identifies the Primitive Request
MAC_address	48	MAC address of the NIU to which a new connection is requested.
Connect_ID	32	Connection identifier; 0 for a new connection
Resource_Type	8	Type of Resource requested
DS_Bandwidth	32	Downstream Bandwidth requested. Not currently used..
DS_Jitter	32	Max. jitter in downstream requested. Not currently used..
US_Bandwidth	32	Upstream Bandwidth requested
Slot_distance	16	Maximum Distance between slots in upstream requested
Encapsulation	8	Type of encapsulation requested. Corresponds to the same field in the Connect Message (i.e. Direct_IP, Ethernet_Mac_Bridging, PPP).
User_Port_valid	8	validity flag of the next field
User_Port_ID	16	Low latency telephony port id
Add_Port_Type	8	Validity flag of the next 4 fields
Source_IP_add	32	IP address that will be used as source for this connection
Source_Port_nb	16	Port number that will be used for this connection
Dest_IP_add	32	IP address that will be used as destination for this connection
Dest_Port_nb	16	Port number that will be used for this connection
Ethernet_add_valid	8	Validity flag of the next 2 fields
Source_Eth_MAC_add	48	Identifies the Ethernet MAC address of the source of the Ethernet frames to be transported within this connection
Dest_Eth_MAC_add	48	Identifies the Ethernet MAC address of the destination of the Ethernet frames to be transported within this connection

This primitive is used by the upper layer to ask for a new resource. The upper layer can ask for a new connection, for the modification of an existing connection (e.g. fixed rate bandwidth or a reservation id), or for a connection release. The answer to this request shall be a <Prim> **MAC_INA_RESOURCE_IND**.

Primitive_Request_ID: Local identifier of the resource request primitive.

MAC_address: MAC address of the NIU concerned by this request.

Connect_Id: Is the identifier of the connection, if it exists.

Resource_Type: Type of Resource requested:

- Bit field:
 - **bit 0** (0x01): a reservation id;
 - **bit 1** (0x02): a new connection in fixed rate mode;
 - **bit 2** (0x04): a new connection in cyclic fixed rate mode;
 - **bit 3** (0x08): upgrade bandwidth of an existing connection;
 - **bit 4** (0x10): release an existing connection;
 - **bits 5 to 8:** reserved (shall be set to 0).

DS_Bandwidth: Downstream Bandwidth requested. Not currently used.

DS_Jitter: Max. Jitter in downstream requested. Not currently used.

US_Bandwidth: Requested bandwidth for Fixed rate mode, unit is slots/100 ms.

Slot_distance: When cyclic assignment is required, maximum distance between the slots, unit is in slots.

Encapsulation: Type of encapsulation requested. Corresponds to the same field in the Connect Message (i.e. Direct_IP, Ethernet_Mac_Bridging, PPP).

User_Port_valid: validity flag of the next parameter (0 means invalid parameter).

User_Port_ID: Low latency Telephone port id.

Add_Port_Type: Bit field that specifies TCP/UDP Port number and IP address validity:

- **bit 0:** next IP address fields are valid;
- **bit 1:** next Port nb fields are valid and are TCP port;
- **bit 2:** next Port nb fields are valid and are UDP port;
- **bits 3 to 7:** Reserved (shall be set to 0).

Source_IP_add: Source IP address attributed to this connection.

Source_Port_nb: TCP or UDP source port number attributed to this connection.

Dest_IP_add: Destination IP address attributed to this connection.

Dest_Port_nb: TCP or UDP destination port number attributed to this connection.

Ethernet_add_valid: The two next fields containing Ethernet MAC addresses are valid (0 if not valid).

Source_Eth_MAC_add: Source Ethernet MAC address attributed to this connection.

Dest_Eth_MAC_add: Destination Ethernet MAC address attributed to this connection.

8.7.2.2 <Prim> MAC_INA_RESOURCE_IND

Parameter	Format	Comment
Primitive_ID	16	0x0812
Primitive_Request_ID	16	Identifies the Primitive Request; 0 if not requested by the STU/Headend Network Adapter
Connect_Id	32	Connection identifier
Resource_Type	8	Type of Resource allocated
Error_Code	32	Specifies the type of error, if happened; zero for no error
DS_Bandwidth	32	Downstream Bandwidth allocated. Not currently used.
DS_Jitter	16	Max. jitter in downstream assigned. Not currently used.
US_Bandwidth	32	Upstream Bandwidth allocated
Slot_distance	16	Maximum Distance between slots in upstream assigned
Encapsulation	8	Type of encapsulation assigned. Corresponds to the same field in the Connect message (i.e. Direct_IP, Ethernet_Mac_Bridging, PPP).
User_Port_valid	8	Validity flag of the next field
User_Port_ID	16	Low latency telephony port id
Add_Port_Type	8	Validity flag of the next 4 fields
Source_IP_add	32	IP address that will be used as source for this connection
Source_Port_nb	16	Port number that will be used for this connection
Dest_IP_add	32	IP address that will be used as destination for this connection
Dest_Port_nb	16	Port number that will be used for this connection
Ethernet_add_valid	8	Validity flag of the next 2 fields
Source_Eth_MAC_add	48	Identifies the Ethernet MAC address of the source of the Ethernet frames to be transported within this connection
Dest_Eth_MAC_add	48	Identifies the Ethernet MAC address of the destination of the Ethernet frames to be transported within this connection

This primitive indicates that the MAC layer has changed or released an existing connection or established a new connection. The connection is either:

- the Default Connection (Connect Message sent by the INA just after the Initialization Complete message);
- a subsequent Connect message;
- an answer to a Resource Request previously sent by the RCTT (see Resource Request primitive);
- an indication of a change in the connection characteristics after reception of a Re provisioning message.

Primitive_Request_ID: Identifies the Primitive Request; 0 if not requested by the STU/Headend Network Adapter.

Connect_Id: Is the identifier of the connection, if it exists.

Resource_Type: Type of Resource requested:

- Bit field:
 - **bit 0** (0x01): a reservation id;
 - **bit 1** (0x02): a new connection in fixed rate mode;
 - **bit 2** (0x04): a new connection in cyclic fixed rate mode;
 - **bit 3** (0x08): upgrade bandwidth of an existing connection;
 - **bit 4** (0x10): release an existing connection;
 - **bits 5 to 8:** reserved (shall be set to 0).

Error_Code: If not Null, the primitive is an answer to a previous MAC_Resource_REQ, and the request failed. The Error_Code values correspond to the problem (refer to clause 8.4.9.10).

If value is 0, the Resource has been successfully set.

DS_Bandwidth: Downstream Bandwidth requested. Unit Not currently used.

DS_Jitter: Max. Jitter in downstream requested. Not currently used.

US_Bandwidth: Requested bandwidth for Fixed rate mode, unit is slots/1 200 ms.

Slot_distance: When cyclic assignment is required, maximum distance between the slots, unit is in slots.

Encapsulation: Type of encapsulation requested. Corresponds to the same field in the Connect Message (i.e. Direct_IP, Ethernet_Mac_Bridging, PPP).

User_Port_valid: validity flag of the next parameter (0 means invalid parameter).

User_Port_ID: Low latency Telephone port id.

Add_Port_Type: Bit field that specifies TCP/UDP Port number and IP address validity:

- **bit 0:** next IP address fields are valid;
- **bit 1:** next Port nb fields are valid and are TCP port;
- **bit 2:** next Port nb fields are valid and are UDP port;
- **bits 3 to 7:** Reserved (shall be set to 0).

Source_IP_add: Source IP address attributed to this connection.

Source_Port_nb: TCP or UDP source port number attributed to this connection.

Dest_IP_add: Destination IP address attributed to this connection.

Dest_Port_nb: TCP or UDP destination port number attributed to this connection.

Ethernet_add_valid: The two next fields containing Ethernet MAC addresses are valid (0 if not valid).

Source_Eth_MAC_add: Source Ethernet MAC address attributed to this connection.

Dest_Eth_MAC_add: Destination Ethernet MAC address attributed to this connection.

8.8 Data Primitives

The primitives series is related to implementations where the MAC DVB-RC entity insures the LLC function:

- In upstream, it consists in AAL5 reassembly and datagram recomposition following the encapsulation mode of the connection (i.e. Direct IP, Ethernet MAC bridging, PPP). The unit data are the datagrams.
- In downstream, it consists in the MPE protocol filtering before datagram recomposition as in upstream.

8.8.1 <Prim> DL_DATA_IND

Parameter	Format	Comment
Primitive_ID	16	0x1001
Connect_ID	32	Connection identifier
Length	16	Length of the data buffer contained in the primitive
Data buffer	8[Length]	Received Datagram

This primitive is used to transfer the application data filtered by the MAC layer. The Connection identifier can be used to multiplex more efficiently the buffer when several connections exist.

8.8.2 <Prim> DL_DATA_REQ

Parameter	Format	Comment
Primitive_ID	16	0x1002
Connect_ID	32	Connection identifier
Length	16	Length of the data buffer contained in the primitive
Data buffer	8[Length]	Datagram to be transmitted

The MAC layer is asked to transmit a network layer datagram. It will insure the segmentation function (and will use, in the NIU case, the upstream transmission mode of the connection).

8.8.3 <Prim> DL_DATA_CONF

Parameter	Format	Comment
Primitive_ID	16	0x1003
Connect_ID	32	Connection identifier
Result	32	Success or reason of the failure. A value of 0 means the success of the previous Data Request, any other value will be used to indicate the reason of the failure (as mentioned below).

This primitive is sent as an answer to a previous **DL_DATA_REQ**.

The Result parameter specifies the result of its execution. It can take the following values:

- **"OK"**: The transmission succeeded.
- **"Contention_Error"**: (NIU only) Contention_retry_count slots have not been acknowledged (in Contention mode), the transmission has stopped.
- **"Reservation_Failure"**: (NIU only) The reservation request did not succeed (no answer from the INA to the request).
- **"Reservation_Abort"**: (NIU only) Reservation request can be answered by several consecutive Grant messages, the sum of slots allocated in the successive Grant messages shall then be equal to the requested number. This error occurs when Grant messages do not complete the number of slots in a pre-defined time-out.
- **"Mode_Not_Permitted"**: (NIU only) If the application wants to use a transmission mode not allowed to this connection.
- **"Unknown_Error"**: Error not identified.

8.9 Example MAC Control Scenarios (Informative)

8.9.1 Example MAC Control Scenario on RCTT Side

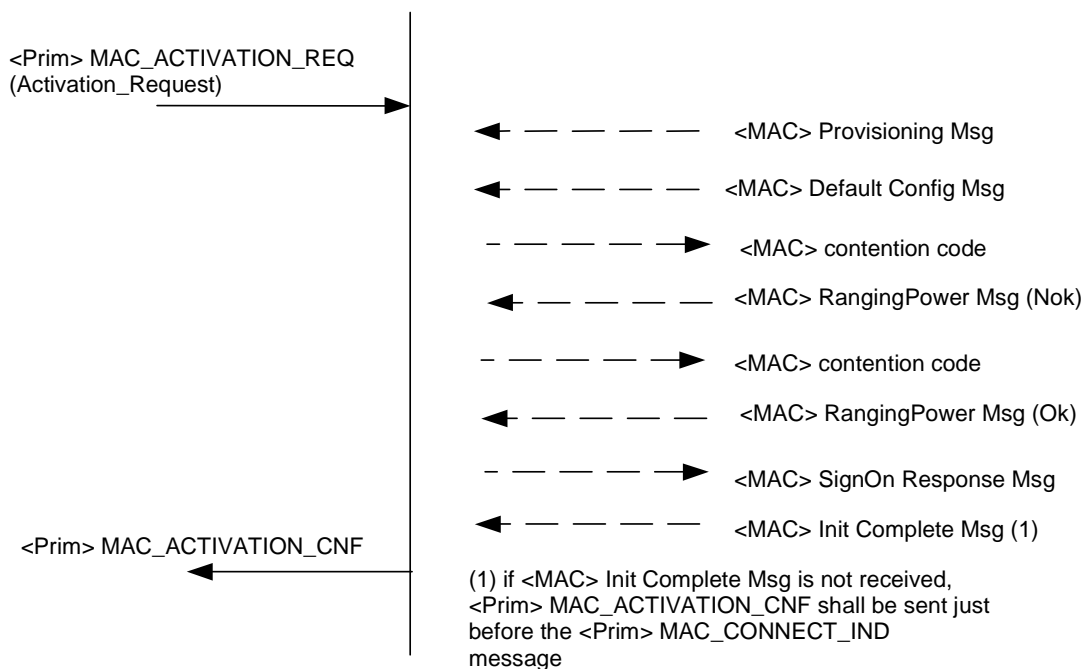

8.9.2 Example Resource Management Scenario on RCTT Side

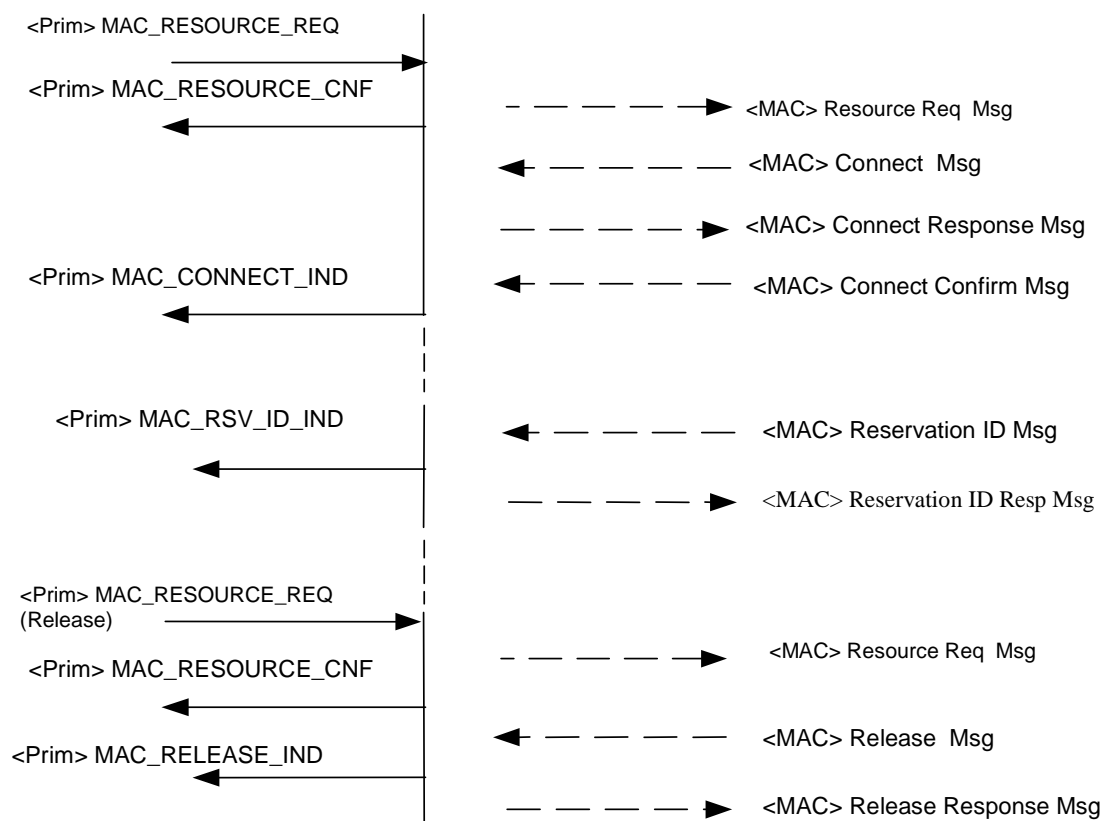

8.9.3 Example Resource Management Scenario on INA Side

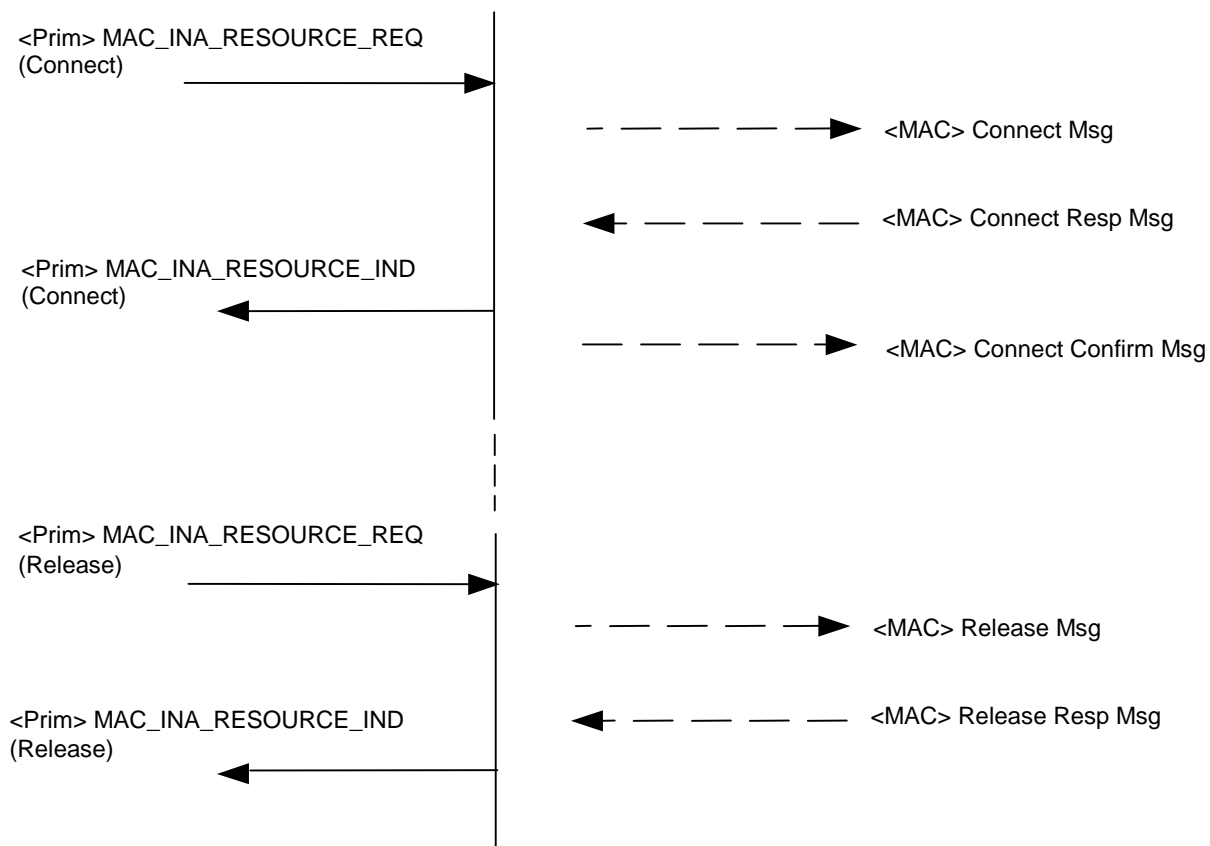

8.9.4 Example Upstream Data Transfer Scenarios

Contention mode

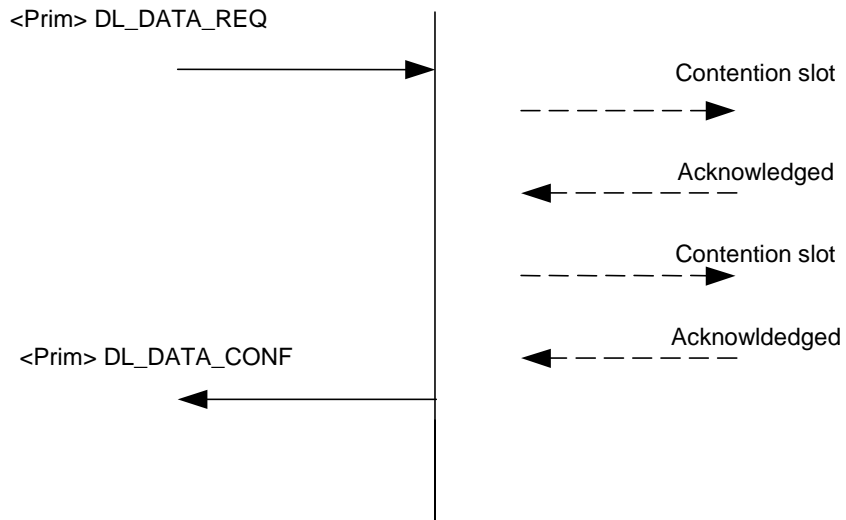

Fixed rate mode

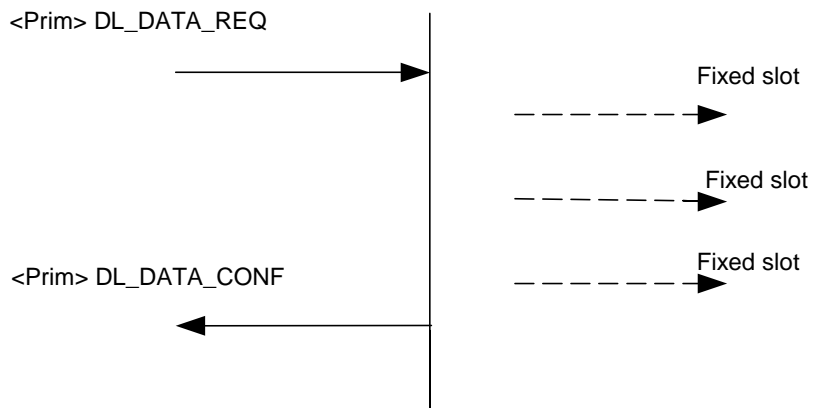

Reservation mode

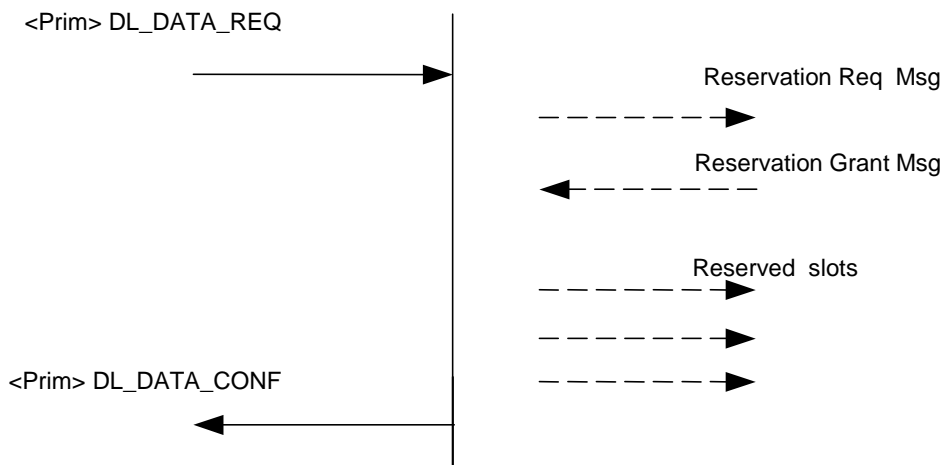

Annex A (informative): Compatibility issues, Frequency allocation, Frequency range

A.1 Strategies for gaining Access to Spectrum for DVB-RCT

To allow the deployment of the DVB-RCT systems, it will be important to decide on what basis spectrum licences for RCTTs will be sought - i.e. on a:

- PRIMARY basis; or
- SECONDARY (non interference to Primary services) basis.

A major CEPT UHF Re-planning Conference is scheduled for 2005. This means that throughout Europe, there will be major reforming of the UHF spectrum within the next ten years or so. Regulators and Spectrum managers may look very unfavourably on any mass-market consumer equipment that cannot automatically realign itself with the new frequency assignments. The costs of manually tuning millions of items of consumer equipment would cost hundreds of millions of Euro and will in all likelihood have to be paid for by the Service Providers.

In many countries it may also prove very difficult to obtain licences on a Primary basis in the VHF/UHF bands for RCTTs complying with DVB-RCT.

Accordingly, different strategies for gaining access to spectrum may be required from country to country.

A.2 Preliminary considerations on frequency allocation

In the DVB-RCT system, the Forward Interaction path and the Return Interactive path are implemented in the same radio frequency bands - i.e. VHF/UHF Bands III, IV and V.

The DVB-T and DVB-RCT systems form a two-way Hertzian system (like Radio Telephone systems) which share the same frequency bands. Thus it is possible to benefit from common features in regard to the RF devices and parameters (antenna, combiner, propagation conditions, etc.). Nevertheless, the RCT system is suited to work in other frequency bands preferably adjacent to broadcasting.

Figure 54 gives a broad indication of a possible spectrum allocation within the TV broadcasting bands. The Return Interaction Channel can be located in any free segment of an RF channel, taking in account existing national and regional analogue television assignments, interference risks and future allocations for DVB-T.

The existing 7/8 MHz channelling plan (Stockholm 1961) allows a TV channel to be split into 7/8 segments of 1 MHz, in order to increase the efficiency of spectrum usage. The deployment of small sectorised cells is a very interesting opportunity to increase the capacity of a given amount of spectrum without causing interference to existing and planned broadcast services. The non-uniform distribution of energy in analogue TV RF channels lends itself ideally to this approach.

However, specific sharing rules will have to be agreed for DVB-RCT transmissions in the spectrum currently assigned to broadcasting. The upcoming review of the Stockholm plan (ITU conference in 2005) will give opportunities to interested parties to address these aspects in depth.

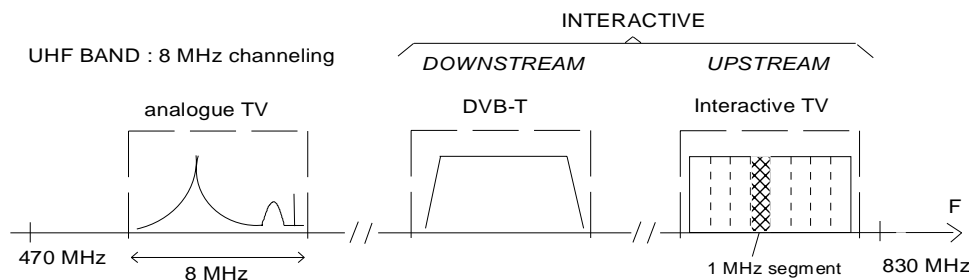

Figure 54: Sharing of Return Channel spectrum within UHF Broadcasting Bands

A.3 Possible Allocation Mechanisms

There are two possible approaches to spectrum allocation for DVB-RCT:

- **Fixed Allocation:** means that part of the UHF spectrum currently allocated to terrestrial TV broadcasting is reserved on a regional, national or international basis for the interactive DVB-RCT service transmissions. A Fixed Allocation on a limited portion of the band will reduce the RF design constraints to achievable technical standards (especially for the duplexer design) and could lead to device costs appropriate to mass-market products.

The upper edge of the UHF band is well suited for such a fixed allocation as it would leave the TV broadcast reception band as a continuous segment, allowing the use of a very simple low-pass design for the duplexer. A brief survey of the current TV allocations throughout Europe concludes that the upper part of Band V, (channels 67 and 68) is the best candidate band in the short term. Only a few transmitters are deployed in that part of the Band (mostly due to sharing constraints with Military Forces).

This band allows also for better availability and performance of RF components (because of their widespread use of the 900 MHz band in the GSM mobile industry).

However this part of the Band V has been assigned to DVB-T in several European countries. Moreover, in the long term, it is also foreseen (see CEPT/DSI recommendation on spectrum usage after 2000) that when analogue transmitters have been switched off, the upper part of Band V may be given back to national regulatory bodies. Nevertheless, this band could also be partially allocated to DVB-RCT services as required.

- **Dynamic Allocation:** means that the DVB-RCT transmissions from the RCTTs can occur anywhere in a "free or underused" segment (1 MHz) of the VHF/UHF bands. The spectrum segment could be then selected by means of an assignment from the DVB-RCT Base Station. In these circumstances, it is important that the selected spectrum segment remains within the overall allocation of the Operator concerned and that the compatibility criteria with other channels are maintained (e.g. duplex distance if Duplexers are used).

With Dynamic Allocation the RF stage (i.e. up-converter, amplifier and duplexer devices (if used)) have to be designed to cover the whole VHF/UHF band. Accordingly, it has to be broadband and the cost of the RF stage will be increased somewhat. Moreover, the filtering and duplexer devices have to be tuneable by external commands from the IIM (to avoid deployment of dedicated equipment tuned to specific frequencies on a regional or local basis).

From an ease of access to spectrum perceptible and a spectrum efficiency point of view, the Dynamic Allocation scheme is preferred, as it allows the use of the entire available spectrum - which may be unusable for any other purpose. Nevertheless, if Duplexers are used, the cost aspects may limit this technique to only some parts of the UHF bands.

However, if Switched FDD and Burst Structure 3 are used (duration of transmissions from the RCTTs < 2 ms) many of the spectrum access and cost problems can be overcome - by using "smart" switching and "smart" MPEG decoding.

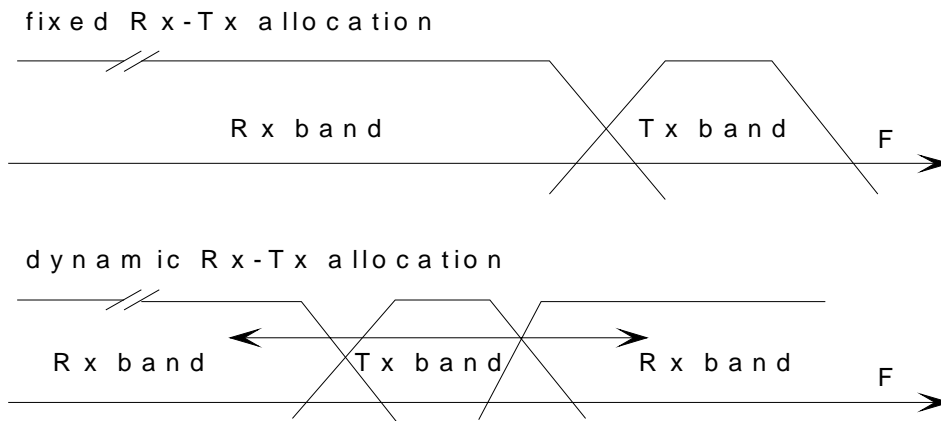

Figure 55: Possible Frequency Allocation Techniques

A.4 Compatibility issues

In a first instance, the RCTTs transmissions are considered as unwanted emissions in the VHF/UHF bands. Detailed investigations on the compatibility issues are therefore required to evaluate the interference risks at both ends of the link.

At the User Side, TV reception shall be protected during the interactive transmission periods (self interference) as well as interference to neighbouring TV sets. Therefore specific rules for TV reception protection need to be respected - such as avoiding transmission on adjacent channels and channels where the receiver has spurious responses (image, etc.).

Conversely, it is required to insure that the RCTTs signals can cope with the radio environment at the Base Station location, where high power transmitters and distant interferers may affect the received interactive signals, which will, by their nature, be weak. This point is not addressed in these specifications as classical engineering mitigation techniques can be used.

A.4.1 Compatibility at the user side

The following clauses give indications and brief engineering options on the possible ways to minimize the compatibility issues when introducing RCT in the broadcasting bands.

The possible antenna arrangements at the user side are depicted in annex 13. Two broad options will be addressed:

- A Single Antenna shared by the Rx and the Tx paths: in this case, the receiving antenna should be as broadband as possible in order to transmit any frequency in the UHF bands with VSWR performance lower than 2,0 (return loss < 8 dB). No filtering or amplifying device along the coaxial section (selective antenna coupler, preamplifier) should inhibit the transmission. Using a Duplexer or a Switch enables this antenna sharing method.
- Separate Antennas for the Rx and the Tx paths. When TV reception is via a non bi-directional antenna system (due to the presence of a preamplifier or SMATV line amplifier) separate Rx and Tx antennas may be required.

A.4.2 Duplexer

The main features of the duplexer are:

- to enable coupling of Rx (reception) and Tx (transmission) ports to the antenna port in the wanted frequency bands with a sufficient isolation.
- to offer sufficient Tx out-of band filtering performances to meet regulatory and compatibility constraints (spurious emissions).

Figure 56 gives an overview of such Duplexer devices.

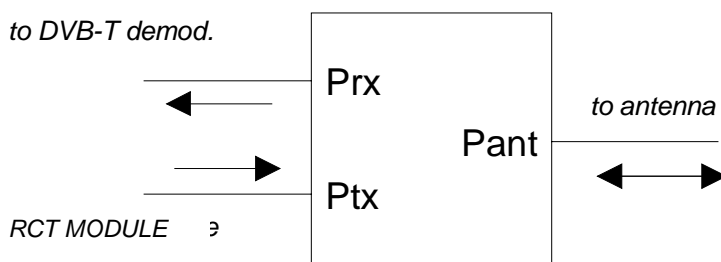

Figure 56: Duplexer device synopsis

Two options are possible for the design depending on the adopted transmission mode:

- **Pure FDD mode:** simultaneous reception and transmission is required; isolation between ports is provided by filters and a coupler. When there is no active DVB-RCT transmission, the FDD duplexer can be by-passed by means of a switch. This would eliminate the > 3 dB loss of receive signal during normal (non interactive) viewing of interactive DVB-T - i.e. for > 99 % of the time.
- **Switched FDD mode:** reception can be briefly interrupted (< 3 ms) to transmit short bursts of data. Isolation between ports is provided by means of the Switch. Burst Structure 3 is best suited to this mode of operation. In this mode the RCT transmission will appear as a burst of Gaussian Noise and precautions will need to be taken to ensure continued very tight synchronization with the downstream DVB-T signal.

Figure 57 and figure 58 give an overview of the two possible techniques.

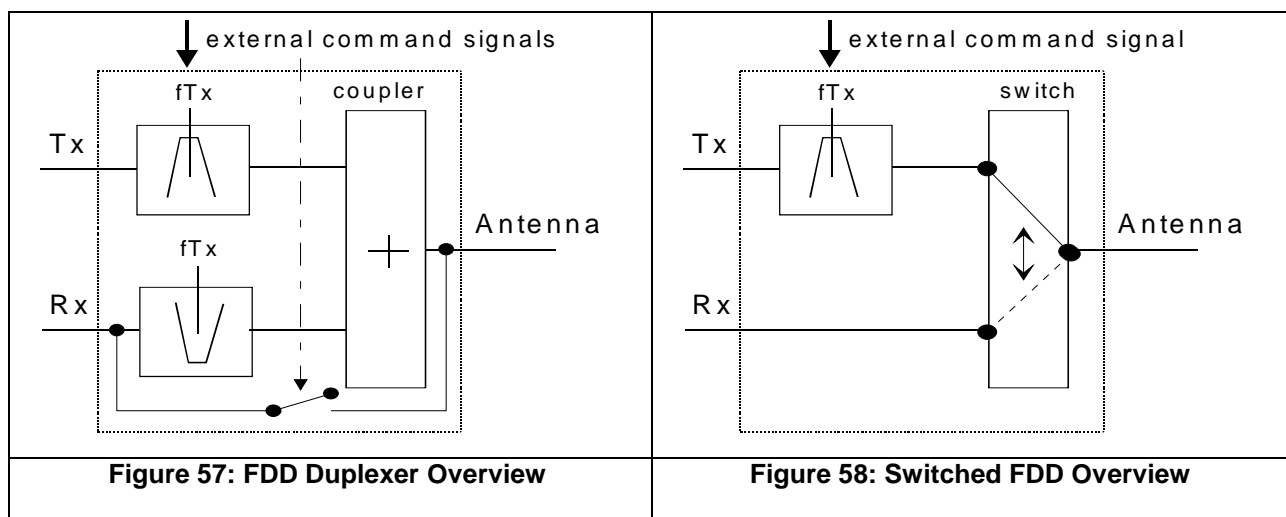

Figure 57: FDD Duplexer Overview

Figure 58: Switched FDD Overview

Elements	Role	Requirements
Band-pass and band-stop filters centred on fTx and fRx	Filtering: limits the radiated (to antenna port) and conducted (to Rx port) out-of-band products e.g. wide band noise, spurious,... Isolation: between Tx and Rx ports to avoid overwhelming of the receiver front end stage	Tx: see spectrum mask Rx: depending on receiver blocking figure, 30 dB rejection on FTx should be sufficient
Coupler, switch	Connection of the Tx, Rx ports to the antenna with additional isolation	low insertion loss < 1,5 dB low insertion loss < 4 dB coupler < 1 dB switch

In case of Fixed Frequency Allocation and limited Tx and Rx bandwidth, a duplexer can be realized at low cost with the required performance using high Q-value dielectric ceramic resonators (as for radio-mobile handsets). However, in many countries it may be very difficult to obtain licences for RCTTs with fixed filters, as there will be major re-farming of the UHF spectrum over the next ten years. Regulators and Spectrum managers may look very unfavourably on large-scale deployment of consumer equipment, which cannot automatically realign itself with the new frequency assignments.

In the case of Dynamic Frequency Allocation, the band pass filters have to be tuned over wide frequency ranges. This may involve instances of "overlapping" use of spectrum i.e. the Tx Channel between 2 Receive Channels. The filters (and Switch) need to be driven by an external signal provided by the IIM. Since there is no possibility of getting an external signal to drive the Rx filter from the BIM, it is preferable to use a coupled configuration of a band-pass and a band-stop filter driven by a single signal coming from the IIM and centred on f_{Tx} .

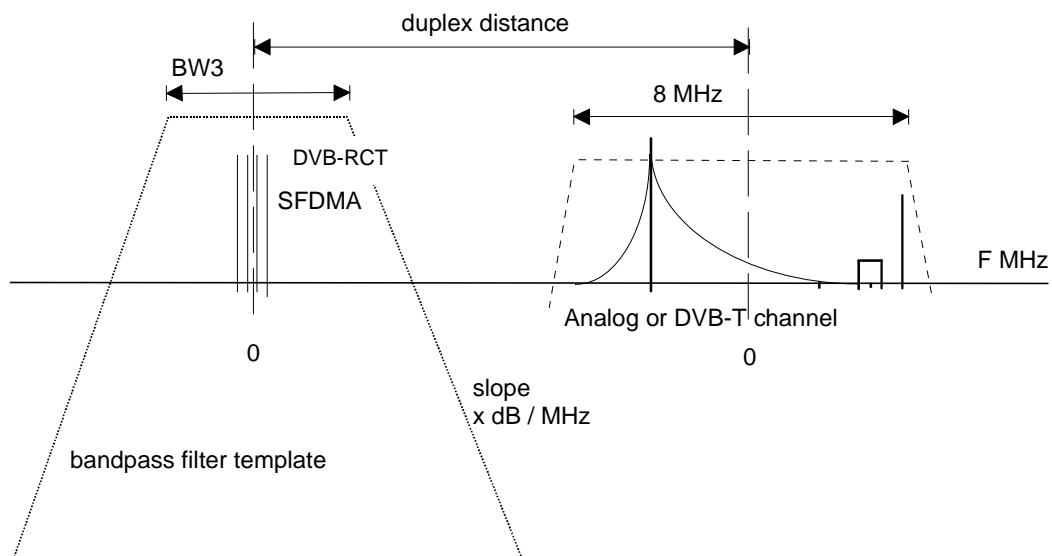

Figure 59: Definition of Duplex Distance

Annex B (informative): Return Channel RF Link budgets and service ranges

The service range given for the different transmission modes and configurations can be calculated using the following RF figures derived from current DVB-T implementation guidelines (as user antenna locations, gains, etc. in the fixed and portable modes) and propagation models for rural and urban areas. In order to limit the RCTT's RF power to reasonable limits, it is recommended to put the burden on the Base Station side by using high gain antennas with sectorization schemes and optimized reception configurations: low noise receivers, high Q cavity filters, vertical beam tilted antennas to reject distant interferers.

To define mean service ranges, table 86 details the RF configurations for different Carrier Spacing (Cs) and modulation levels for 800 MHz, in transmission modes BS1, 2 BS3. Operational C/N are derived from EN 300 744 [1] and considering +2 dB implementation margin, +1 dB gain due to turbo-code/concatenated RS+Convolutional codes, +1 dB gain when using time interleaving in Rayleigh channels.

Table 86: parameters for service range simulations

Transmission modes	Outdoor	Indoor 1	Indoor 2	Indoor 3	Indoor 4
Antenna location	Rural/fixed	Indoor urban/portable DVB-T mode			
Frequency	800 MHz				
Carrier spacing	1 kHz	1 kHz	2 kHz	4 kHz	4 kHz
Propagation channel	Rice	Rayleigh			
Modulation scheme	4QAM ½	4QAM ½	16QAM ½	64QAM ½	64QAM ¾
C/N EN 300 744 [1]	3,6 dB	3,6 dB	11,2 dB	16 dB	21,7 dB
Operational C/N	5 dB	5 dB	11 dB	16 dB	22 dB
Antenna height (INA side)	150 m	50 m			
Antenna gain (INA side)	16 dBi (sectorized 60°)				
INA Receiver Noise Figure (Optimized)	2 dB				
Man made noise contribution	2 dB (rural)	5 dB (urban)			
Receiver sensitivity equiv. Min field strength	-135 dBm -16 dBµV/m	-132 dBm -13 dBµV/m	-123 dBm -4 dBµV/m	-115 dBm +4 dBµV/m	-109 dBm +10 dBµV/m
Antenna height (user side)	Outdoor 10 m	indoor 10 m (2d floor)			
Antenna gain (user side)	13 dBi (directive)	3 dBi (omnidir)			
Cable loss	4 dB	1 dB			
Duplexer loss	4 dB	1 dB (separate antennas or switch)			
Indoor penet. Loss	/	10 dB (mean 2 ^e floor)			
Propagation models	ITU-R 370	OKUMURA-HATA sub-urban			
Standard deviation for Location variation	10 dB for BS1 (single carrier) 5 dB for BS2 and 3 (spreaded multicarrier)				
Margins for 70 % and 90 % location	BS1	13 dB (90 %)	5 dB (70 %)		
	BS2	6,5 dB (90 %)	2,5 dB (70 %)		
	BS3				
Margin for channel selectivity fading	/	0 dB (frequency hopping and diversity mechanisms implemented)			

Reasonable dimensioning of the output amplifier in terms of bandwidth and intermodulation products (linearity) indicates that the 1 dB compression point P1 of the order of +25 dBm to +28 dBm is achievable in 2001 at low cost. However it is expected that with further improvements with linearization and peak clipping techniques it will be possible to economically reach $P1 \geq +30$ dBm within a 2 to 4 year time frame and this will offer greater service ranges).

In order to limit the in-band and adjacent intermodulation products we have to introduce a Power Back-Off (BO) due to modulation peaks and for multiple carrier transmission. The Operational Transmission Power (at amplifier output, before duplexer) becomes then:

$$OTP = P1 - BO \text{ (dBm)}$$

The cumulative distribution function of the peak to average ratio (which is assumed to be equivalent to the required BO) at 10^{-3} probability in single and multi-carrier situation, give following results for the BO (dB). We introduce also the use of linearization techniques with 2 dB to 4 dB mean gains.

Table 87: BO, OTP versus BS and modulation scheme

BS/BO dB	4QAM	16QAM	64QAM	Mean BO dB	Linearis. gain dB	final BO dB	OTP @P1 = 28 dBm
BS1 (1 carrier)	5	6	7	6	2	4	24
BS2 (4 carriers)	8	9	9,5	9	4	5	23
BS3 (29 carriers)	9	10	11	10	4	6	22

Table 88 helps to derive mean service ranges given in figure 60 for each burst structure by considering absolute and relative gain and losses of the Tx back-off, and Rx sensitivity (multicarrier) and diversity (indoor and outdoor standard deviation variations).

Table 88: power back-off versus BS for service range calculations

	Tx BO loss dB	Rx sensitivity loss dB	Rx Diversity gain dB		Total BO/P1 dB		BO/BS1 dB	
			outdoor	indoor	outdoor	indoor	outdoor	indoor
BS1 (1 carrier)	-4	0	0	0	-4		0	
BS2 (4 carriers)	-5	-6	+6,5	+2,5	-4,5	-8,5	-0,5	-4,5
BS3 (29 carriers)	-6	-14	+6,5	+2,5	-13,5	-17,5	-9,5	-13,5

Figure 60 gives the service range of the 5 transmission configurations for the 3 burst structures (and the relative OTP limits) versus an operational transmission power (at amplifier output, before duplexer) ranging from 0 dBm to +24 dBm max (i.e. P1 = +28 dBm).

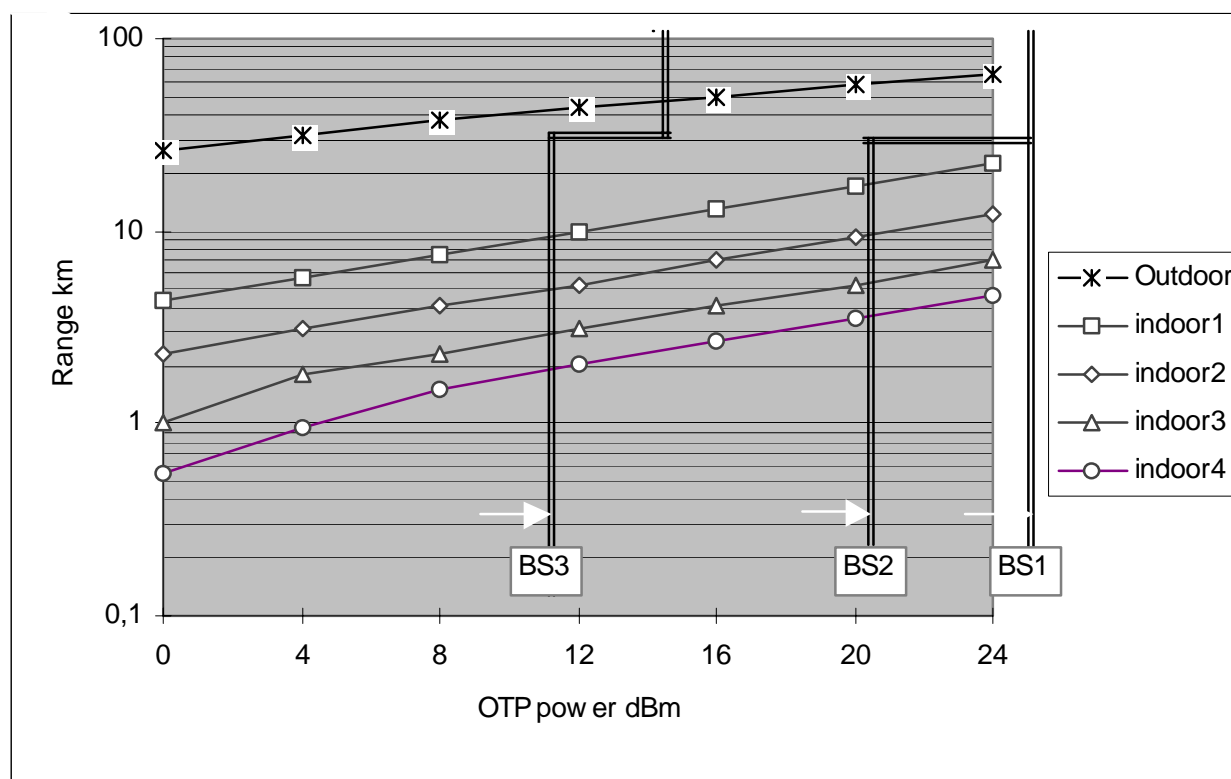
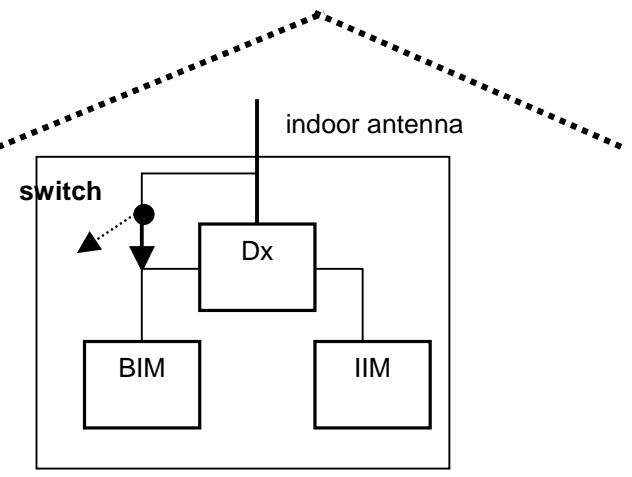
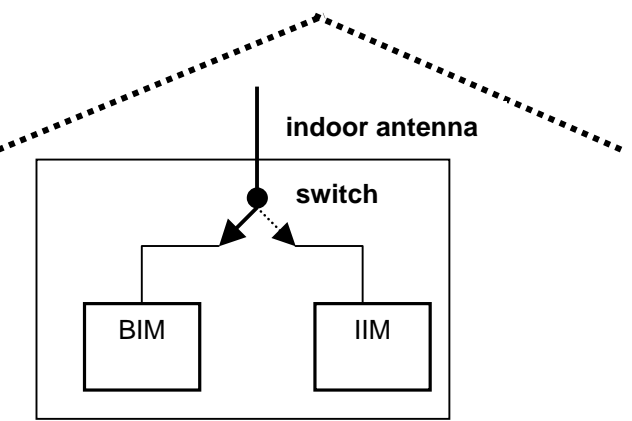
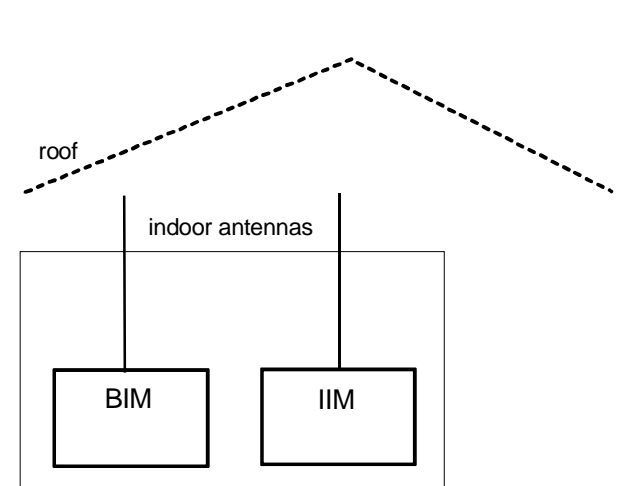

Figure 60: Service ranges/transmission power for BS1, BS2 and BS3

NOTE: The calculations are indicative since they are based on the use of free (non-occupied) spectrum where the link budget is only limited by thermal and man-made noise. In practical networks where sharing with Terrestrial Broadcast TV has to be taken into account, the noise floor will be increased by the accumulated spurious of local transmissions and distant interferers, hence the theoretical service ranges could be lower (especially for reception on high rural sites). However, central frequency assignment techniques can be used to seek the clearest spectrum in each location as described in the Dynamic Frequency Allocation section above.

Annex C (informative): TV reception/RCT Txm arrangements

	<p>BIM and IIM with outdoor antenna using Duplexer</p> <p>Benefits:</p> <ul style="list-style-type: none"> - high Rx and Tx antenna gain - antenna above clutter (height \approx 10 m) - reuse of receive antenna - symmetric RF paths <p>Drawbacks:</p> <ul style="list-style-type: none"> - Tx and Rx Duplexer insertion loss: $>$ 4 dB - (Rx loss eliminated if Switch is used across Duplexer as shown. Switch is only opened during RCT transmission (\ll 1 % of time for interactive TV)) - restricted frequency flexibility because of Duplex Distance - expensive - feeder Loss $<$ 5 dB <p>Requirements:</p> <ul style="list-style-type: none"> - broadband (UHF) antenna system - no tap insertion for additional TV sets
	<p>BIM and IIM with outdoor antenna using a Switch</p> <p>Benefits:</p> <ul style="list-style-type: none"> - no $>$ 4 dB insertion loss on Rx or Tx - very low cost - total frequency flexibility (if wideband antenna used) - high Rx and Tx antenna gain - antenna above clutter (height \approx 10 m) - reuse of existing antenna - symmetric RF link Budget <p>Drawbacks:</p> <ul style="list-style-type: none"> - can only be used with BS3 and to a lesser extent with BS2 <p>Requirements:</p> <ul style="list-style-type: none"> - broadband (UHF) antenna system - no tap insertion for additional TV sets
	<p>BIM on outdoor antenna, IIM on indoor antenna</p> <p>Benefits:</p> <ul style="list-style-type: none"> - improved isolation between Rx and Tx antennas - reuse of existing receive antenna - no duplexer with $>$ 4 dB losses - Total Frequency Flexibility - low cost <p>Drawbacks:</p> <ul style="list-style-type: none"> - low indoor antenna gain and indoor penetration loss (Tx) i.e. 15 dB to 20 dB approx. higher Tx power required compared with rooftop Tx antenna - Asymmetric RF Link Budget <p>Requirements:</p> <ul style="list-style-type: none"> - broadband (UHF) antenna (Tx)

	<p>BIM and IIM with indoor antenna using Duplexer (Dx)</p> <p>Benefits:</p> <ul style="list-style-type: none"> - Portability <p>Drawbacks:</p> <ul style="list-style-type: none"> - duplexer Rx and Tx insertion loss: > 4 dB (Rx loss eliminated if Switch is used across Duplexer as shown. Switch is only opened during RCT transmission (<< 1 % of time for interactive TV apps.)) - Reduced Frequency Flexibility - High Cost - low antenna gain and indoor penetration loss - much reduced Rx coverage range and 15 dB to 20 dB higher Tx power compared with rooftop antenna <p>Requirements:</p> <ul style="list-style-type: none"> - broadband (UHF) antenna system - improved BIM immunity
	<p>BIM and IIM with indoor antenna using Switch</p> <p>Benefits:</p> <ul style="list-style-type: none"> - portability i.e. no "technical" installation - no > 4 dB insertion loss on Rx or Tx - very low cost - total frequency flexibility <p>Drawbacks:</p> <ul style="list-style-type: none"> - low antenna gain and indoor penetration loss giving much reduced Rx coverage range and 15 dB to 20 dB higher Tx power compared with rooftop antenna <p>Requirements:</p> <ul style="list-style-type: none"> - can only be used with BS3 and to a lesser extent with BS2
	<p>BIM and IIM on separate indoor antennas (1)</p> <p>Benefits:</p> <ul style="list-style-type: none"> - portability - diversity possibility - no 4 dB duplexer (coupler) losses <p>Drawbacks:</p> <ul style="list-style-type: none"> - low antenna gain and indoor penetration loss giving much reduced Rx coverage range and 15 dB to 20 dB higher Tx power compared with rooftop antenna - low isolation between antennas at reasonable separation <p>Requirements:</p> <ul style="list-style-type: none"> - broadband (UHF) antennas

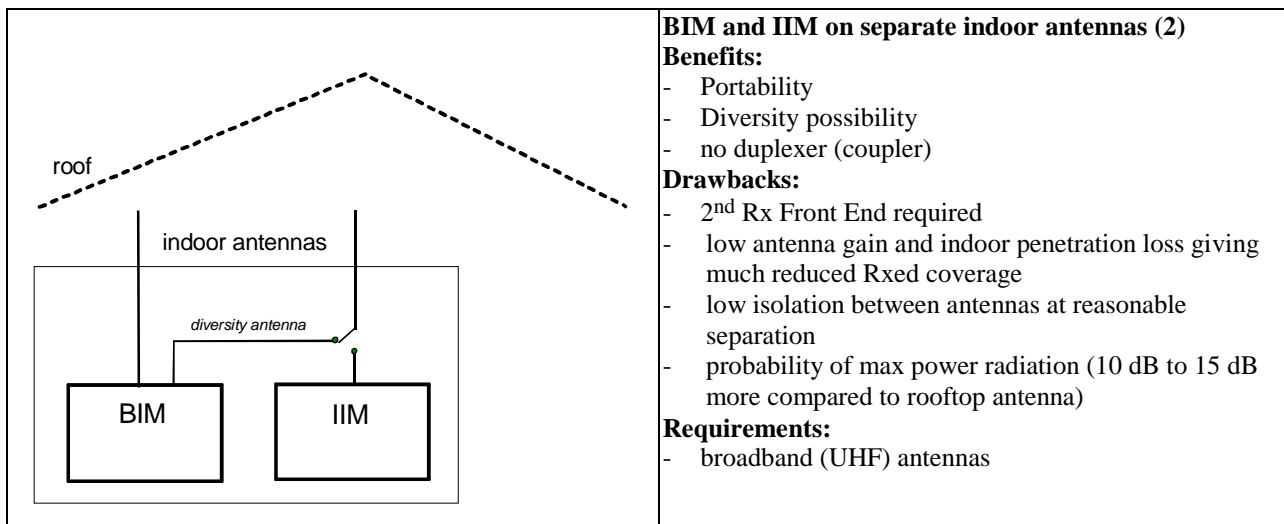

Figure 61: antenna arrangements

Possible reception/transmission arrangements in Multiple Dwelling Units (MDU) are presented in figure 62.

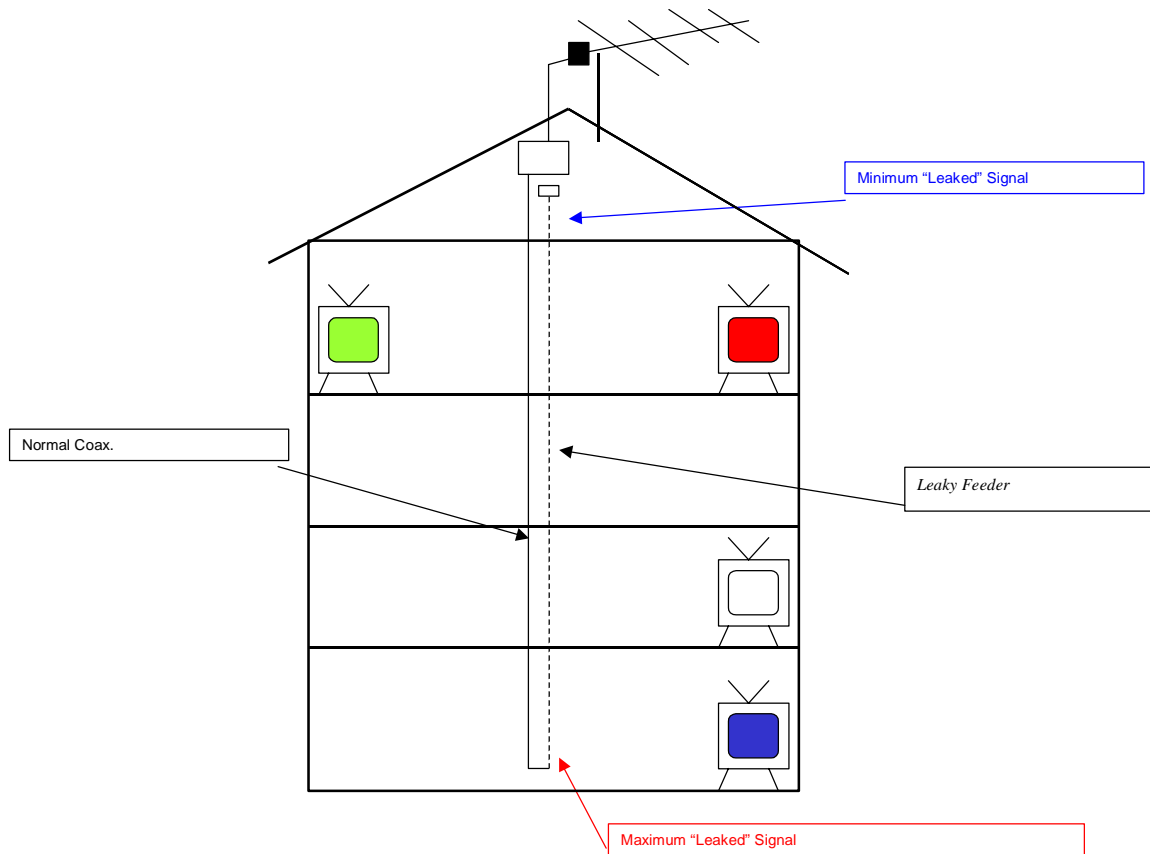

Figure 62: Multiple Dwelling Units (MDU) antenna arrangements

Annex D (informative): Structure and specification of the RCTT's RF stage

The generic block diagram of a RCTT's Radio Frequency stage is depicted in figure 63.

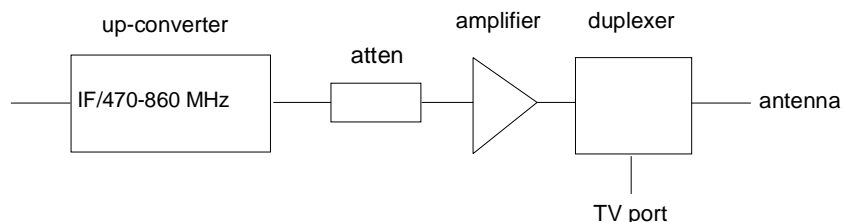

Figure 63: RF stage Block Diagram

Role of the different elements

- Up-converter: translates the Baseband Signal into UHF/VHF bands (see table 89) via IF stage;
- Atten: enables power control mechanisms (can be implemented in BB, IF and RF stages);
- Amplifier: amplifies the upconverted signal to the wanted output power;
- Duplexer: filters out spurious emissions, enables sharing of the antenna, protects receiver from blocking/overload.

External control signals

- frequency reference;
- frequency translation;
- power control and amplifier switch on-off.

Main specifications

Table 89: RF specifications for the end stage

RCT Frequency bands	VHF: 170 MHz to 230 MHz UHF: 470 MHz to 860 MHz
Frequency steps	coarse steps: 125 kHz in up-converter fine steps: 20 kHz in base-band
Frequency stability	locking on an external reference required, stability depends on the selected transmission mode and shall be better than: 1 % of Carrier Spacing
Phase Noise in UHF and VHF	better than -70 dBc/Hz at 1 kHz
Power Control	range: 70 dB, max step amplitude: 3 dB
Max Total Output Power before duplexer	+25 dBm (min) +30 dBm (max)
Output Power Variation over logical bandwidth (after duplexer)	±0,5 dB
Output Power Variation over defined frequency bands (after duplexer)	±2 dB
Spurious Emissions	see template in main specification
Duplexer specifications	switched FDD still under consideration

Annex E (informative): MAC Specification and Description Language (SDL)

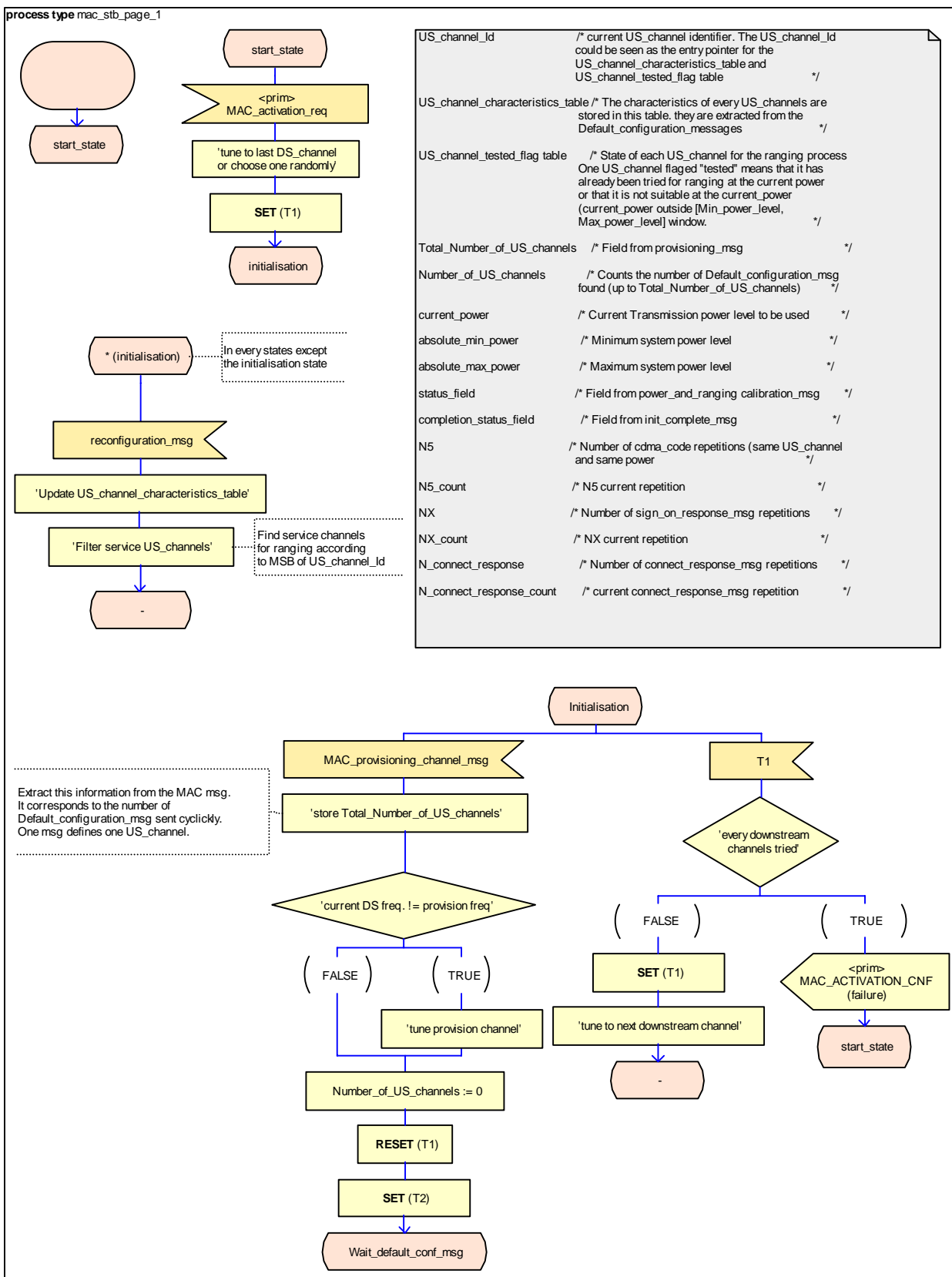

process type mac_stb_page_2

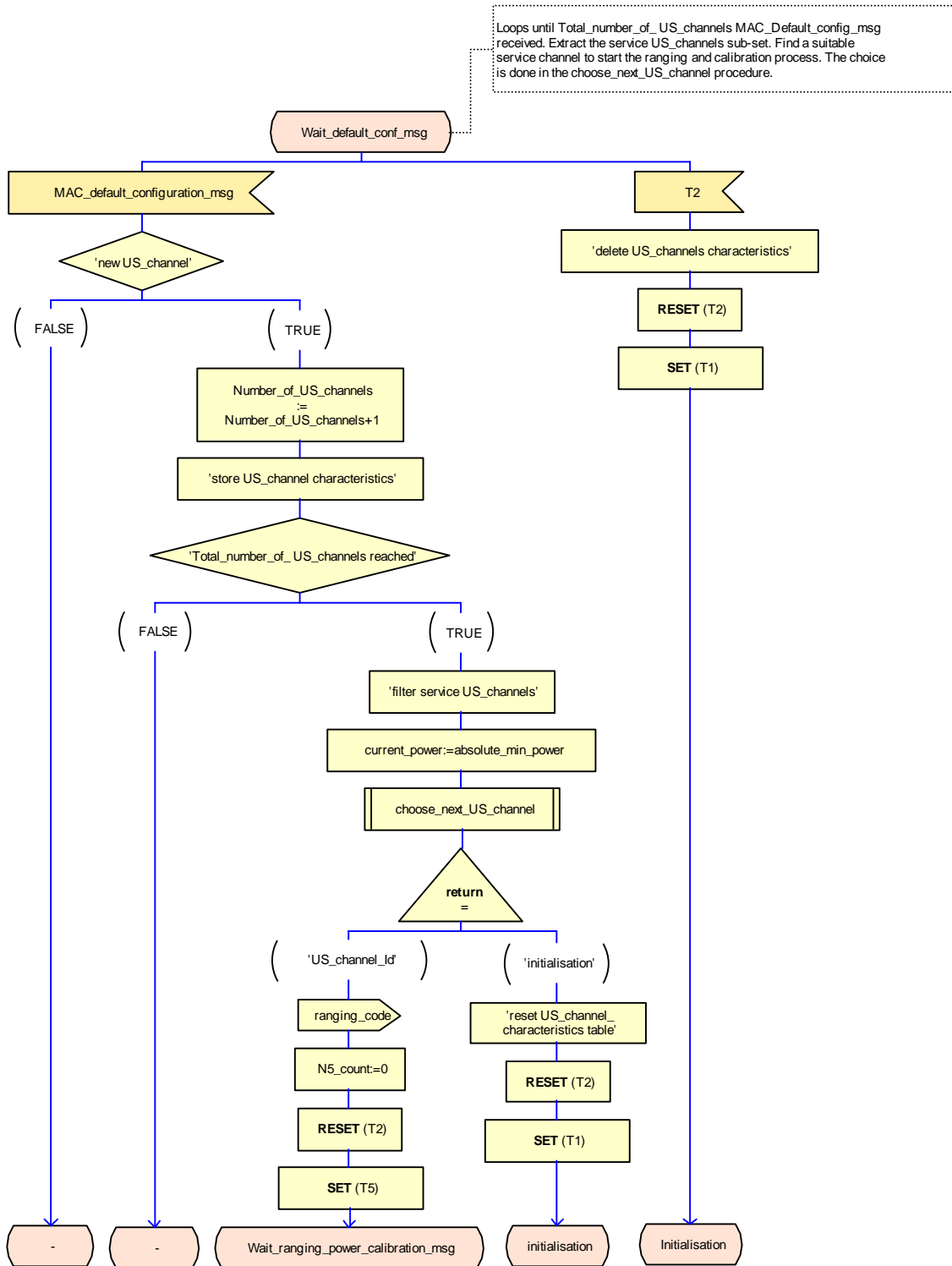

process type mac_stb_page_3

This state makes the ranging and calibration. The NIU tries to reach the INA sending up to N5 times a ranging_code at the same power on one US_channel. If no answer, tries on the other US_channel at the same power. If every suitable US_channels are tried without succes, the process starts again at an increased power level.
 Procedure "choose_next_US_channel" is in charge of the US_channel choice and the power level increase.
 On receipt of a "power_ranging_calibration_msg", ranging and power parameters are adjusted, and the process continues or stops, depending on the "status_field". "success" initiates the sign_on, "errors" aborts and returns to initialisation, "continues" asks for a new calibration loop.

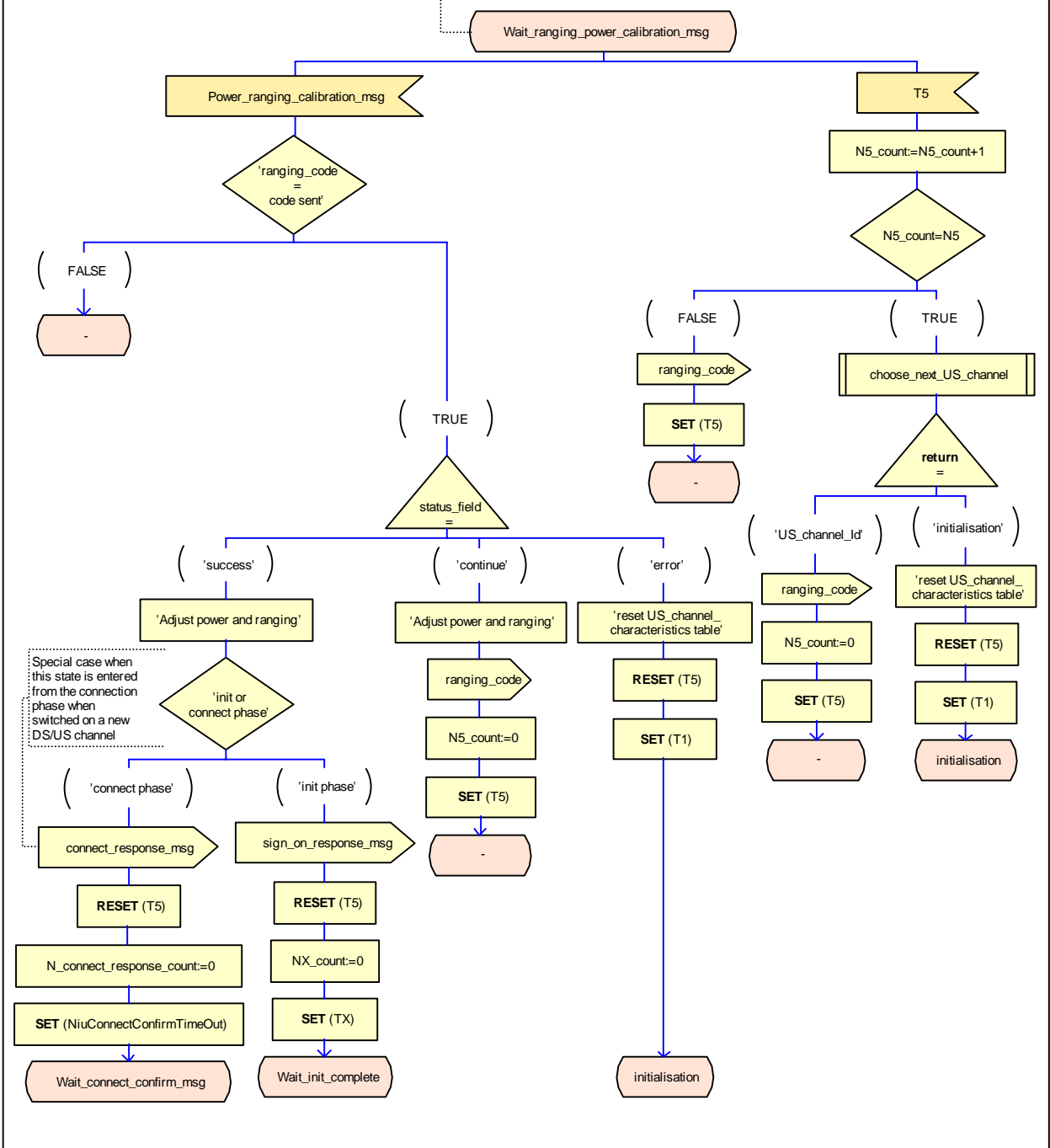

Special case when this state is entered from the connection phase when switched on a new DS/US channel

process type mac_stb_page_4

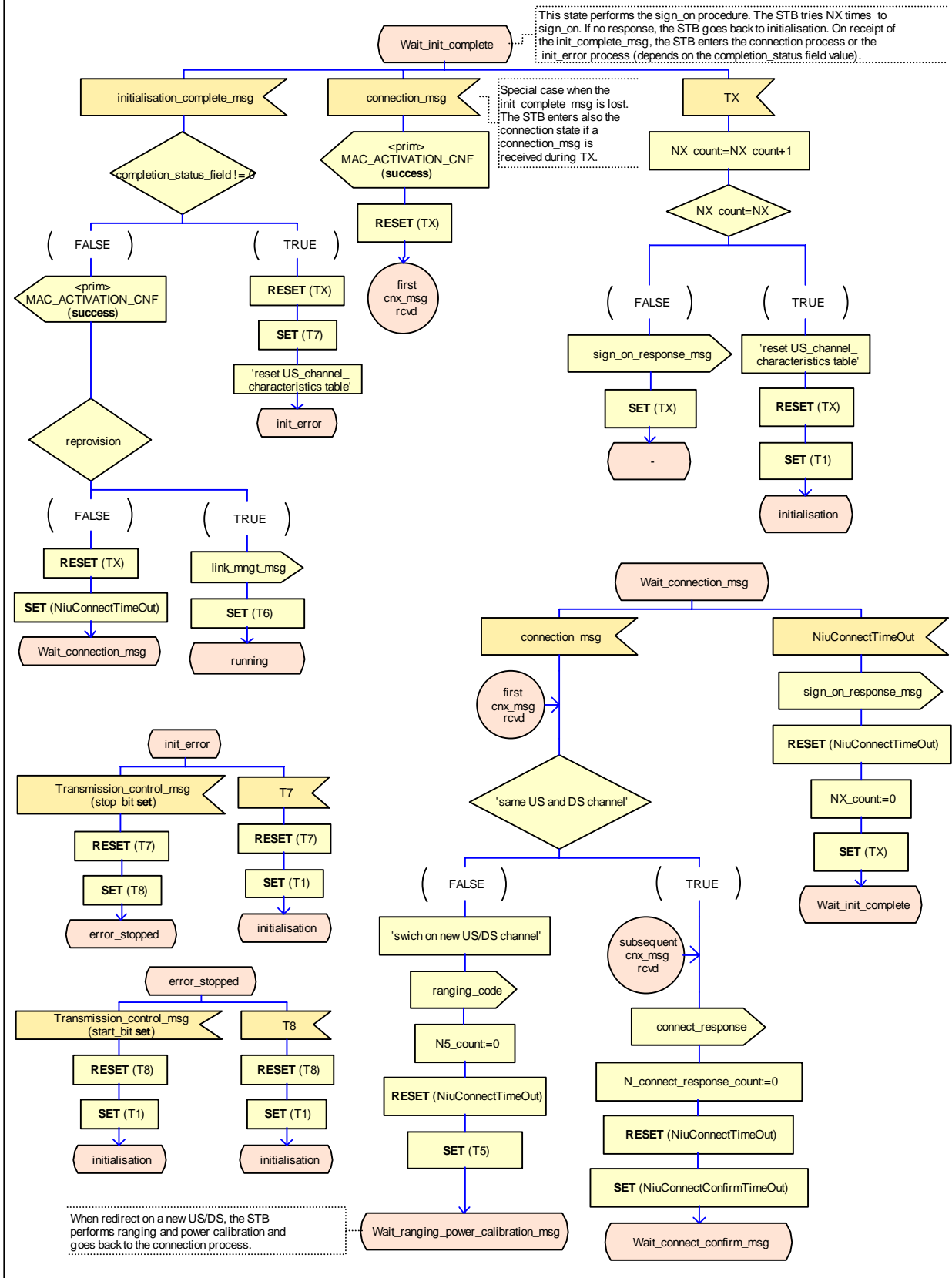

process type mac_stb_page_5

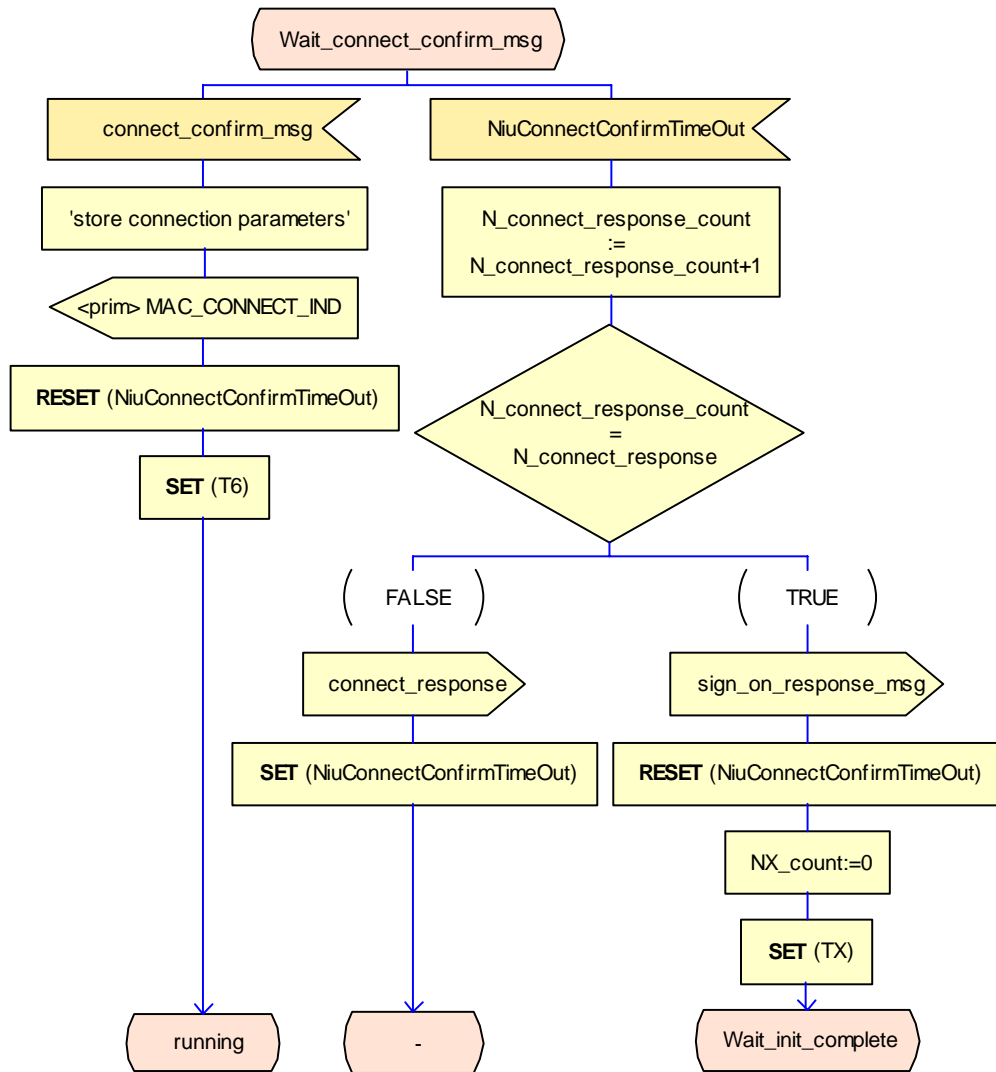

process type mac_stb_page_6

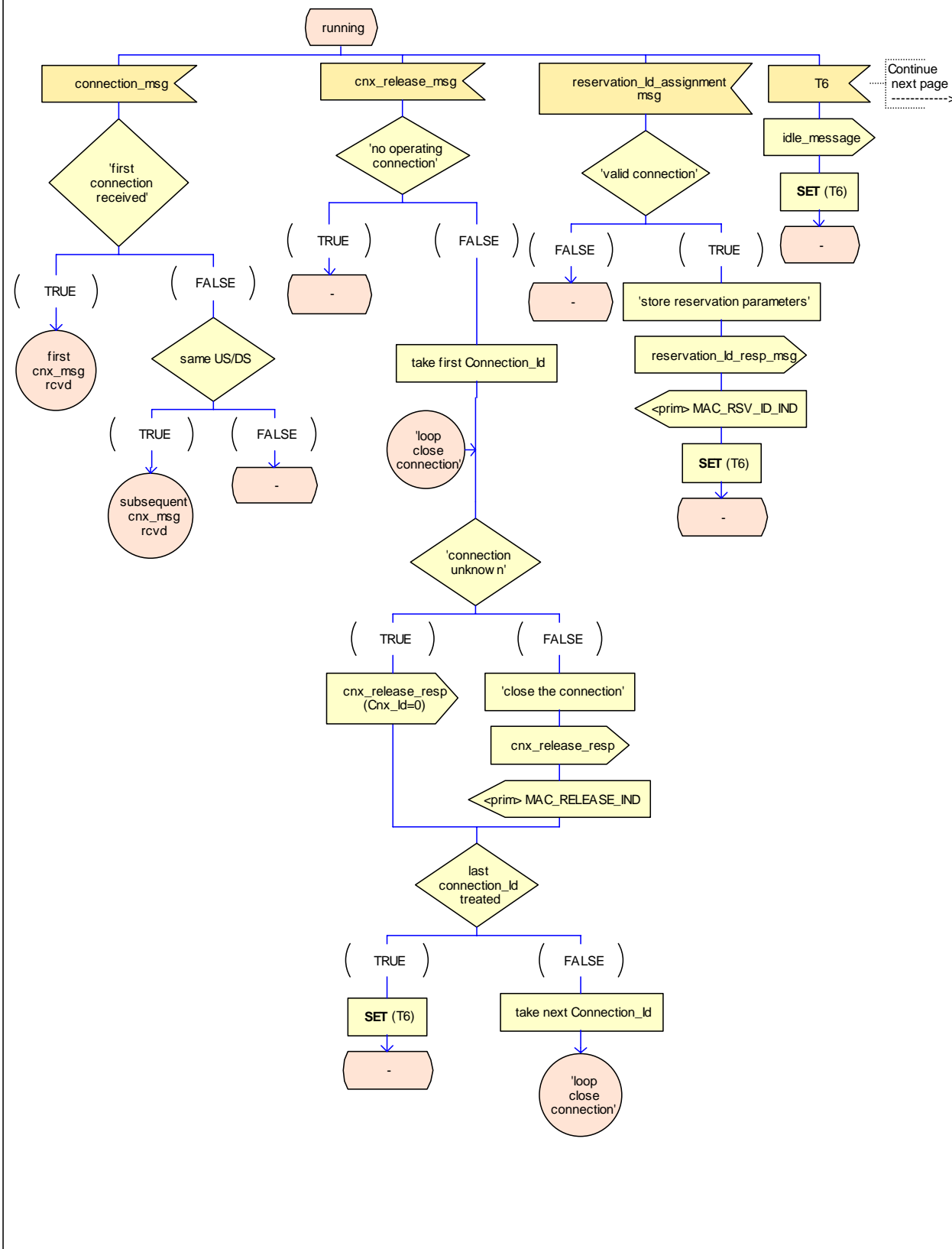

process type mac_stb_page_7

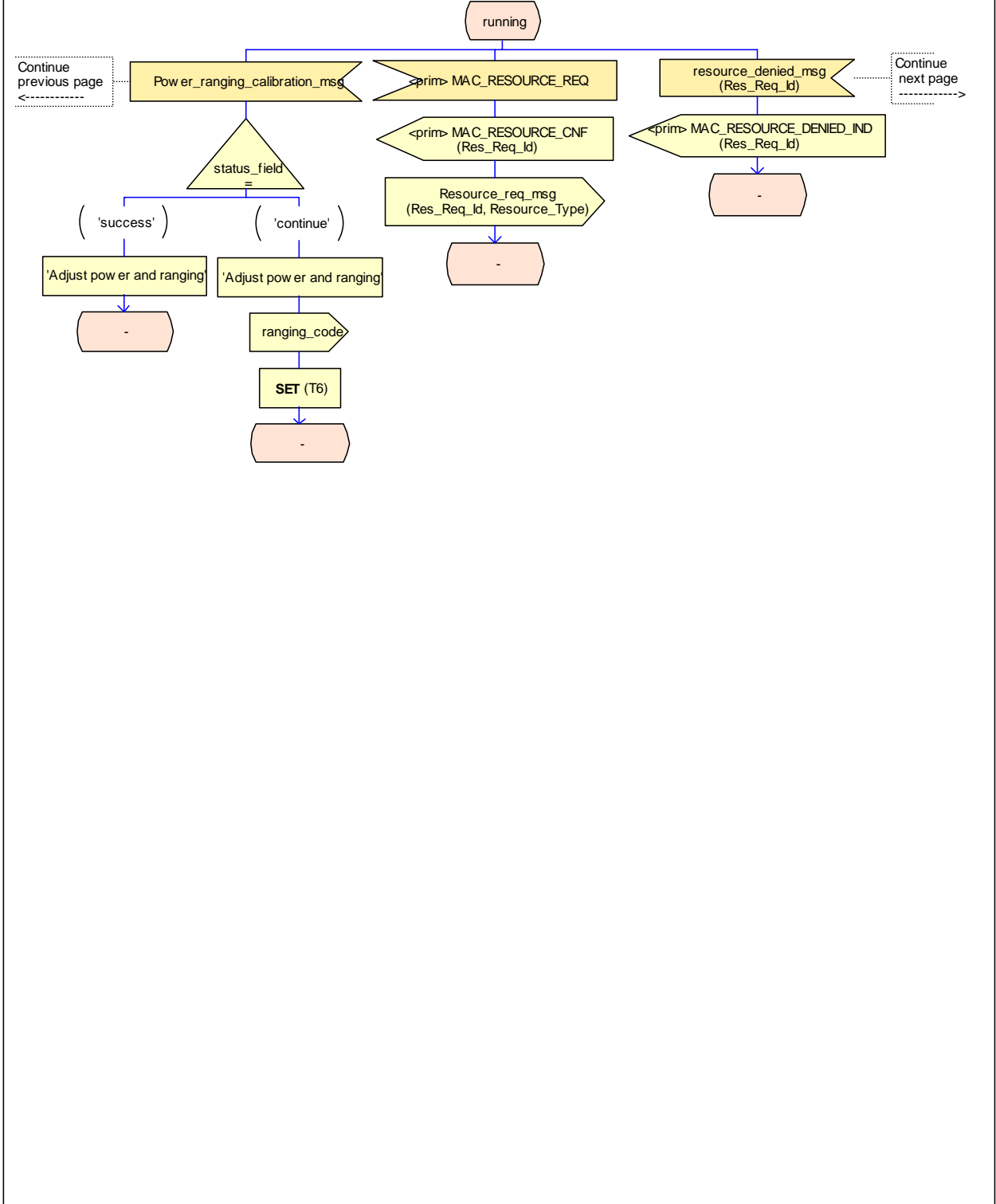

process type mac_stb_page_8

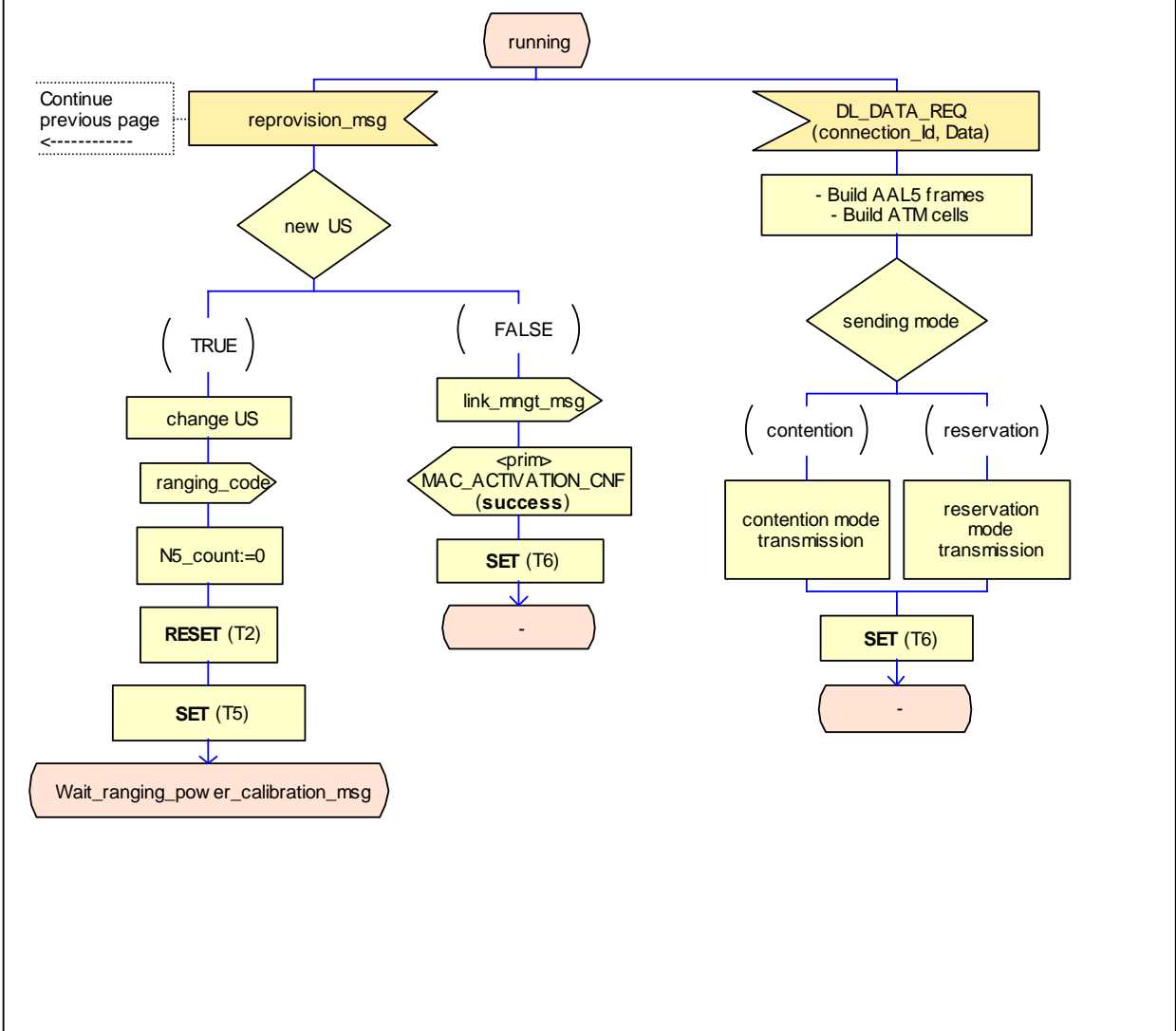

procedure choose_next_US_channel

```

/* variables from process mac_stb */
current_power
Absolute_max_power
US_channel_tested_flag
US_channel_id
US_channels_characteristics table
    
```

This test takes every service US_channels with $Min_power_level \leq current_power \leq Max_power_level$ not yet tried at the current power (US_channel_tested_flag not set) and choose one randomly. If no more US_channels meet these characteristics, the test returns FALSE.

Note that: Min_power_level and Max_power_level are part of the US_channels_characteristics extracted from the Default_configuration_msg (field Min_power_level and Max_power_level).

This procedure allows to choose the US_channel to be used for ranging and power calibration. Basically, it proposes each service US_channel one after the other at the same power level. Once every US_channels have been tested, the power is increased and the loop starts again. This is done up to the maximum Absolute power.

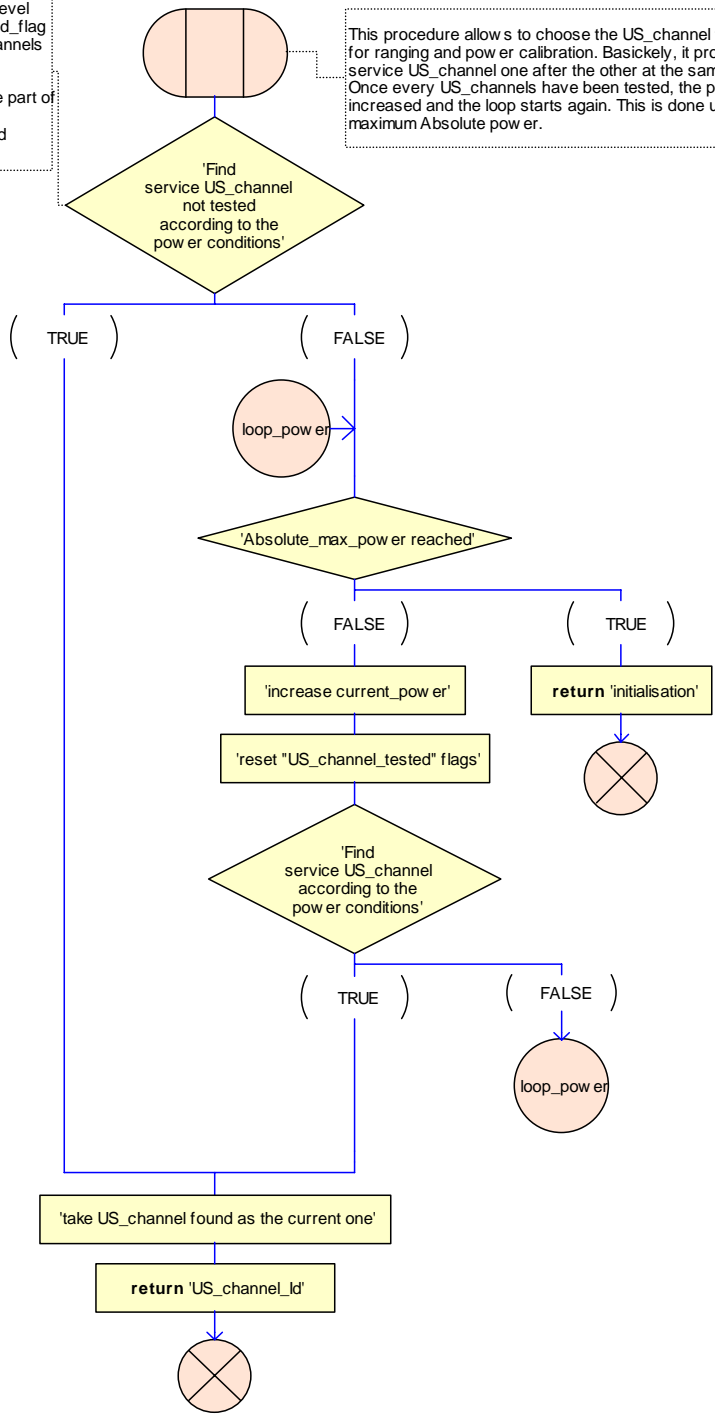

Annex F (informative): Bibliography

- ETSI EG 200 800: "Digital Video Broadcasting (DVB); Interaction channel for Cable TV distribution systems (CATV)".
- ETSI ETS 300 802: "Digital Video Broadcasting (DVB); Network-independent protocols for DVB interactive services".
- American National Standard X3.92-1981: "Data Encryption Algorithm".
- American National Standard X3.106-1983: "Modes of Operation for the Data Encryption Algorithm".
- IETF RFC 1483: "Multiprotocol Encapsulation over ATM Adaptation Layer 5".
- IETF RFC 2131: "Dynamic Host Configuration Protocol (DHCP)".
- IETF RFC 791: "Internet Protocol".
- ATMF UNI 3.1: "ATM Forum User-Network Interface, Version 3.1".
- IETF RFC 2236: "Internet Group Management Protocol, Version 2".
- ETSI TR 100 815: "Digital Video Broadcasting (DVB); Guidelines for the handling of Asynchronous Transfer Mode (ATM) signals in DVB systems".
- ITU-T Recommendation Z.100: "Specification and description language (SDL)".

History

Document history				
V1.1.1	August 2001	Public Enquiry	PE 20011207:	2001-08-08 to 2001-12-07
V1.1.1	December 2001	Vote	V 20020222:	2001-12-24 to 2002-02-22