

Draft **ETSI EN 301 926** V1.3.0 (2017-06)



**Satellite Earth Stations and Systems (SES);
Radio Frequency and Modulation Standard
for Telemetry, Command and Ranging (TCR)
of Communications Satellites**

Reference

REN/SES-00401

Keywords

coding, modulation, satellite, telemetry

ETSI

650 Route des Lucioles
F-06921 Sophia Antipolis Cedex - FRANCE

Tel.: +33 4 92 94 42 00 Fax: +33 4 93 65 47 16

Siret N° 348 623 562 00017 - NAF 742 C
Association à but non lucratif enregistrée à la
Sous-Préfecture de Grasse (06) N° 7803/88

Important notice

The present document can be downloaded from:

<http://www.etsi.org/standards-search>

The present document may be made available in electronic versions and/or in print. The content of any electronic and/or print versions of the present document shall not be modified without the prior written authorization of ETSI. In case of any existing or perceived difference in contents between such versions and/or in print, the only prevailing document is the print of the Portable Document Format (PDF) version kept on a specific network drive within ETSI Secretariat.

Users of the present document should be aware that the document may be subject to revision or change of status. Information on the current status of this and other ETSI documents is available at

<https://portal.etsi.org/TB/ETSIDeliverableStatus.aspx>

If you find errors in the present document, please send your comment to one of the following services:

<https://portal.etsi.org/People/CommiteeSupportStaff.aspx>

Copyright Notification

No part may be reproduced or utilized in any form or by any means, electronic or mechanical, including photocopying and microfilm except as authorized by written permission of ETSI.

The content of the PDF version shall not be modified without the written authorization of ETSI.

The copyright and the foregoing restriction extend to reproduction in all media.

© ETSI 2017.
All rights reserved.

DECT™, **PLUGTESTS™**, **UMTS™** and the ETSI logo are Trade Marks of ETSI registered for the benefit of its Members.
3GPP™ and **LTE™** are Trade Marks of ETSI registered for the benefit of its Members and of the 3GPP Organizational Partners.

oneM2M logo is protected for the benefit of its Members
GSM® and the GSM logo are Trade Marks registered and owned by the GSM Association.

Contents

Intellectual Property Rights	5
Foreword.....	5
Modal verbs terminology.....	5
1 Scope	6
2 References	7
2.1 Normative references	7
2.2 Informative references.....	8
3 Definitions and abbreviations.....	8
3.1 Definitions.....	8
3.2 Abbreviations	11
4 Modulation Requirements	12
4.1 General	12
4.2 Frequency and Phase Modulations	13
4.2.1 Modulating waveforms	13
4.2.2 PCM waveforms and data rates	14
4.2.3 Use of subcarriers	15
4.2.4 Choice of Subcarrier Frequencies.....	15
4.2.5 Uplink Carrier Frequency Deviation (Frequency Modulation).....	16
4.2.6 Uplink PM Modulation Index	16
4.2.7 Downlink PM Modulation Index	16
4.2.8 Sense of Modulation	16
4.2.9 Data Transition Density	16
4.2.10 Modulation Linearity	16
4.2.11 Residual Amplitude Modulation.....	17
4.2.12 Residual Carrier, Out-of-band Emission and Discrete Spectral Lines	17
4.3 Spread Spectrum Modulation	18
4.3.1 General.....	18
4.3.2 Chip Shaping	20
4.3.3 Out-of-Band Emission and Discrete Spectral Lines	20
4.4 Coherency Properties	20
5 Requirements on Transmitted Signals.....	21
5.1 Frequency Stability.....	21
5.1.1 Uplink.....	21
5.1.2 Downlink	21
5.2 Turnaround Frequency Ratio.....	21
5.3 Polarization.....	21
5.4 Phase Noise	21
5.4.1 Ground Transmitter.....	21
5.4.2 On-board Transmitter	22
6 Link Acquisition Requirements.....	22
6.1 Link Acquisition Performance	22
6.2 Physical Layer Operations Procedures.....	22
7 Coding and Interleaving	23
7.1 Uplink.....	23
7.2 Downlink.....	23
Annex A (informative): Operational Configuration.....	24
A.1 Introduction	24
A.2 Configuration Baseline: on board spread spectrum transponder.....	25
A.3 Configuration Alternative 1: on board dual mode receiver and on board dual mode transmitter	26

A.4	Configuration Alternative 2: on board dual mode receiver and phase modulation transmitter.....	27
A.5	Configuration Alternative 3: on board dual mode receiver, phase modulation transmitter and dedicated RG SS transmitter	29
A.6	Configuration Alternative 4: on board dual mode multi-channel receiver and on board dual mode transmitter (for hosted payload management).....	30
Annex B (informative): Hybrid Ranging process description.....		32
B.1	Introduction	32
B.2	Presentation	32
B.3	Distance ambiguity resolution.....	33
Annex C (informative): Modulator imperfections.....		34
C.1	Phase imbalance	34
C.2	BPSK phase imbalance	34
C.3	QPSK phase imbalance	34
C.4	Amplitude imbalance	34
C.5	Data asymmetry.....	35
C.6	Data bit jitter.....	35
C.7	PN code asymmetry.....	35
C.8	PN code chip jitter.....	35
C.9	Chip transition time	35
C.10	I/Q data bit skew	36
C.11	I/Q PN code chip skew.....	36
Annex D (informative): SRRC chip filtering		37
Annex E (normative): PN code assignment, generation and set specification.....		39
E.1	PN codes.....	39
E.2	PN code assignment	39
E.3	PN code generation	39
E.3.1	PN code generator types.....	39
E.3.1a	Telecommand uplink or in-phase channel (Mode MTC2, MTC3 Acquisition)	42
E.3.2	Ranging uplink or quadrature channel (Mode MTC2).....	42
E.3.3	Telecommand and ranging uplink (Mode MTC3 Tracking)	43
E.4	Telemetry Downlink.....	43
E.4.1	Coherent ranging mode (Mode MTM2).....	43
E.4.2	Non coherent mode (Mode MTM3).....	43
E.5	Baseline PN code set specification.....	43
E.6	Extended PN code library.....	45
E.7	Code Examples.....	46
E.8	PN CODE REQUEST FORM.....	49
E.8.1	Form	49
E.8.2	Description and Instructions.....	49
Annex F (informative): Performance computations		51
Annex G (informative): Bandwidth considerations and assumptions		52
History		53

Intellectual Property Rights

IPRs essential or potentially essential to the present document may have been declared to ETSI. The information pertaining to these essential IPRs, if any, is publicly available for **ETSI members and non-members**, and can be found in ETSI SR 000 314: "*Intellectual Property Rights (IPRs); Essential, or potentially Essential, IPRs notified to ETSI in respect of ETSI standards*", which is available from the ETSI Secretariat. Latest updates are available on the ETSI Web server (<https://ipr.etsi.org>).

Pursuant to the ETSI IPR Policy, no investigation, including IPR searches, has been carried out by ETSI. No guarantee can be given as to the existence of other IPRs not referenced in ETSI SR 000 314 (or the updates on the ETSI Web server) which are, or may be, or may become, essential to the present document.

Foreword

This draft European Standard (EN) has been produced by ETSI Technical Committee Satellite Earth Stations and Systems (SES), and is now submitted for the combined Public Enquiry and Vote phase of the ETSI standards EN Approval Procedure.

Proposed national transposition dates	
Date of latest announcement of this EN (doa):	3 months after ETSI publication
Date of latest publication of new National Standard or endorsement of this EN (dop/e):	6 months after doa
Date of withdrawal of any conflicting National Standard (dow):	6 months after doa

Modal verbs terminology

In the present document "**shall**", "**shall not**", "**should**", "**should not**", "**may**", "**need not**", "**will**", "**will not**", "**can**" and "**cannot**" are to be interpreted as described in clause 3.2 of the [ETSI Drafting Rules](#) (Verbal forms for the expression of provisions).

"**must**" and "**must not**" are **NOT** allowed in ETSI deliverables except when used in direct citation.

1 Scope

The present document applies to the Telemetry, Command and Ranging (TCR) system of Communication Satellites (geosynchronous or not), operating in the following frequency bands:

- 5 725 MHz to 7 025 MHz uplink, 3 400 MHz to 4 200 MHz and 4 500 MHz to 4 800 MHz downlink ("C-band");
- 12 750 MHz to 13 250 MHz, 13 750 MHz to 14 800 MHz and 17 300 MHz to 18 400 MHz uplink, 10 700 MHz to 12 750 MHz and 13 400 MHz to 13 650 MHz downlink ("Ku-band");
- 27 500 MHz to 30 000 MHz uplink, 17 700 MHz to 20 200 MHz downlink ("Commercial Ka-band").

Although not explicitly addressed in the present document, possible usage in other bands allocated to FSS/MSS/BSS/SOS between 1 GHz to 51,4 GHz may be envisaged.

The TCR receiver and transmitter can have a frequency flexibility capability over a given RF band, Typical frequency step is 100 kHz.

The present document sets out the minimum performance requirements and technical characteristics of the ground/satellite Radio Frequency (RF) interface based on Frequency Modulation (FM), Phase Modulation (PM) and Code Division Multiple Access (CDMA).

With the growing number of satellites, the co-location constraints and the maximization of bandwidth for Communications Missions, real and potential interference cases have motivated the elaboration of the present document for geostationary satellites based on CDMA techniques.

The present document addresses the following applications:

- Telemetry.
- Command (Telecommand).
- Ranging.
- Hosted Payload Management.

The aim of the present document is to replace and enhance the prior document ETSI EN 301 926 [i.2] (V1.2.1). The present document's provisions also apply for use cases of autonomous control of hosted payloads. It is recognized that hosted payloads may require only a subset of the functionality.

The present document applies to the typical TCR scenario shown on figure 1. The scenario includes multiple satellites, which may be located in the same orbital location (GSO), or that can be in common view of a given TCR station during NGSO phases (such as transfer phase to GEO, or during NGSO operations). These satellites may be controlled by m different TCR ground stations. The TCR links defined in the present document have also to coexist with the communication ground terminals also shown on figure 1. Some of the satellites to be controlled may use FM/PM waveforms, and some may use a CDMA waveform, as defined later in the present document.

The scenario may also include, for some of the satellites, hosted payloads, which can be controlled independently of the satellite platform and of the main payload.

The present document defines the modulation and coding on the TCR and HPM links. Modulation formats are specified in clause 4 and coding in clause 7.

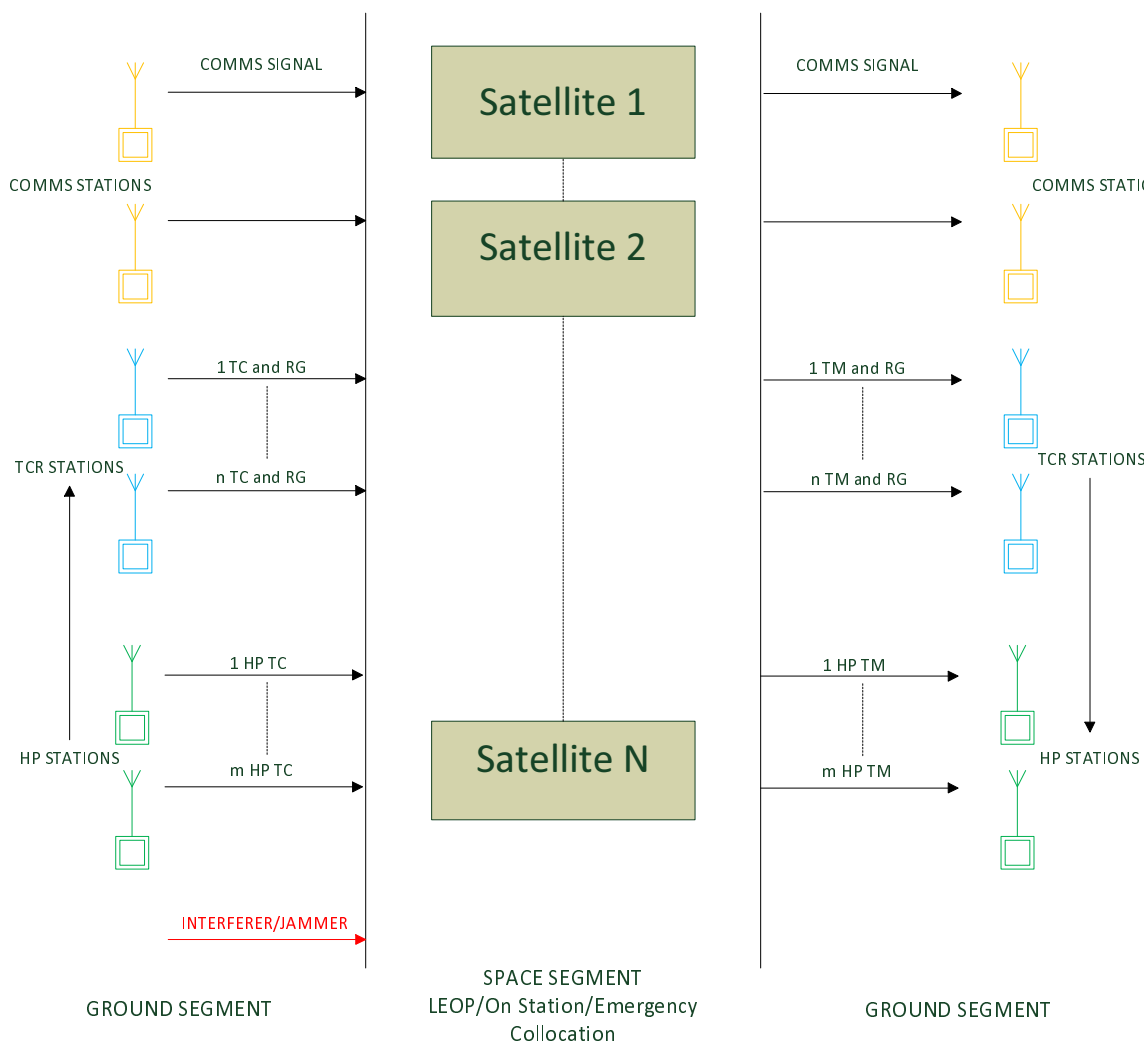

Figure 1: Communications satellites scenario

2 References

2.1 Normative references

References are either specific (identified by date of publication and/or edition number or version number) or non-specific. For specific references, only the cited version applies. For non-specific references, the latest version of the referenced document (including any amendments) applies.

Referenced documents which are not found to be publicly available in the expected location might be found at <https://docbox.etsi.org/Reference/>.

NOTE: While any hyperlinks included in this clause were valid at the time of publication, ETSI cannot guarantee their long term validity.

The following referenced documents are necessary for the application of the present document.

- [1] CCSDS 231.0-B-x: "TC Synchronization and Channel Coding".
- [2] CCSDS 131.0-B-x: "TM Synchronization and Channel Coding".

NOTE: CCSDS standards always include the issue number on their numbering system; the parameter 'x' on references [1] and [2] is understood as the highest published number and therefore latest issue of the standard.

2.2 Informative references

References are either specific (identified by date of publication and/or edition number or version number) or non-specific. For specific references, only the cited version applies. For non-specific references, the latest version of the referenced document (including any amendments) applies.

NOTE: While any hyperlinks included in this clause were valid at the time of publication, ETSI cannot guarantee their long term validity.

The following referenced documents are not necessary for the application of the present document but they assist the user with regard to a particular subject area.

- [i.1] ETSI TR 101 956: "Satellite Earth Stations and Systems (SES); Technical analysis of Spread Spectrum Solutions for Telemetry Command and Ranging (TCR) of Geostationary Communications Satellites".
- [i.2] ETSI EN 301 926 (V1.2.1) (06-2002): "Satellite Earth Stations and Systems (SES); Radio Frequency and Modulation Standard for Telemetry, Command and Ranging (TCR) of Geostationary Communications Satellites".

3 Definitions and abbreviations

3.1 Definitions

For the purposes of the present document, the following terms and definitions apply:

binary channel: binary communications channel (BPSK has 1 channel, QPSK has 2 channels)

channel symbol rate: rate of binary elements, considered on a single wire, after FEC coding and channel allocation

NOTE: See figures 3, 4 and 5. This applies only to multi-channel modulations, thus to spread spectrum QPSK modes and not to PM/FM modes.

Co-located Equivalent Capacity (CEC): number of collocated satellites that can be controlled with a perfect power balanced link between the ground and the satellite

Code Division Multiple Access (CDMA): technique for spread-spectrum multiple-access digital communications that creates channels through the use of unique code sequences

Command Link Transmission Unit (CLTU): telecommand protocol data structure providing synchronization for the codeblock and delimiting the beginning of user data

NOTE: See [1], section 4 for further details.

data rate: total number of uncoded data bits per second after packet and frame encoding

NOTE: See figures 2, 3, 4 and 5. This is the Data Rate used in Link Budgets in ETSI TR 101 956 [i.1].

Direct Sequence Spread Spectrum (DSSS): form of modulation where a combination of data to be transmitted and a known code sequence (chip sequence) is used to directly modulate a carrier, e.g. by phase shift keying

symbol rate: rate of binary elements, considered on a single wire, after FEC coding

NOTE: See figures 2 to 5.

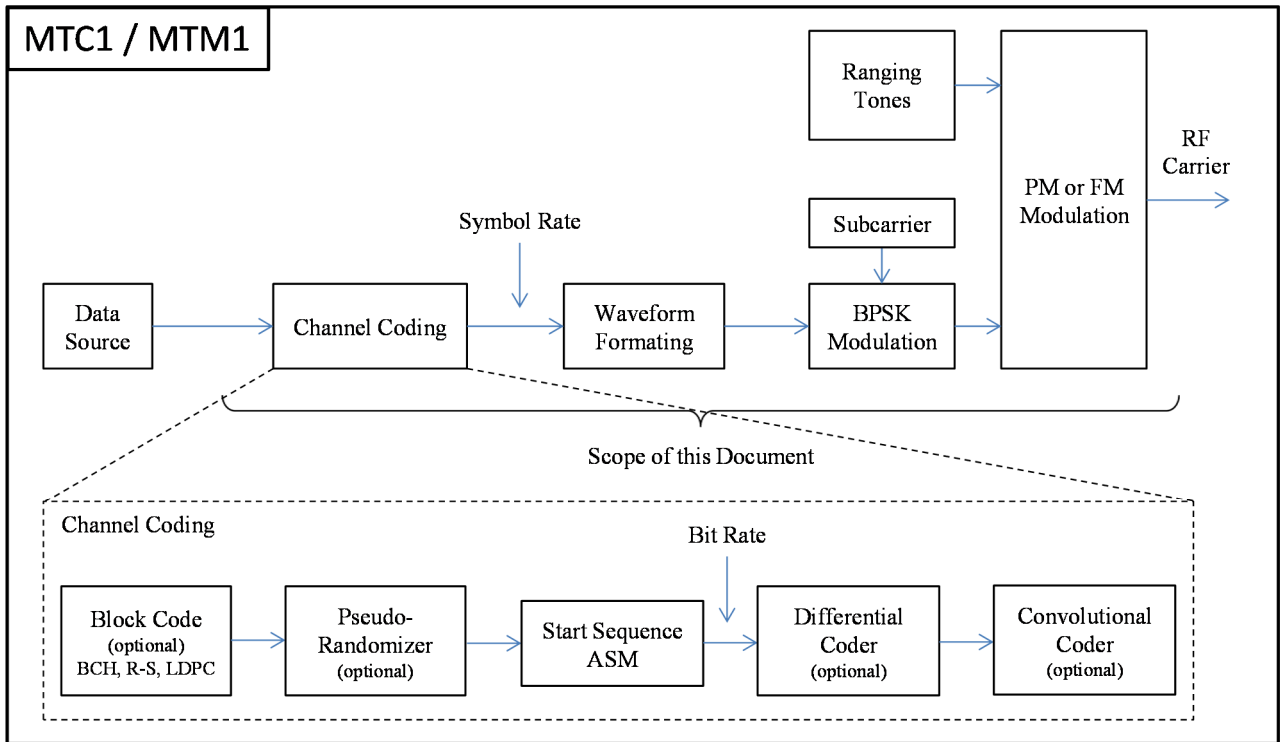

Figure 2: Functional stages of transmit chain for FM/PM modulation (MTC1/MTM1)

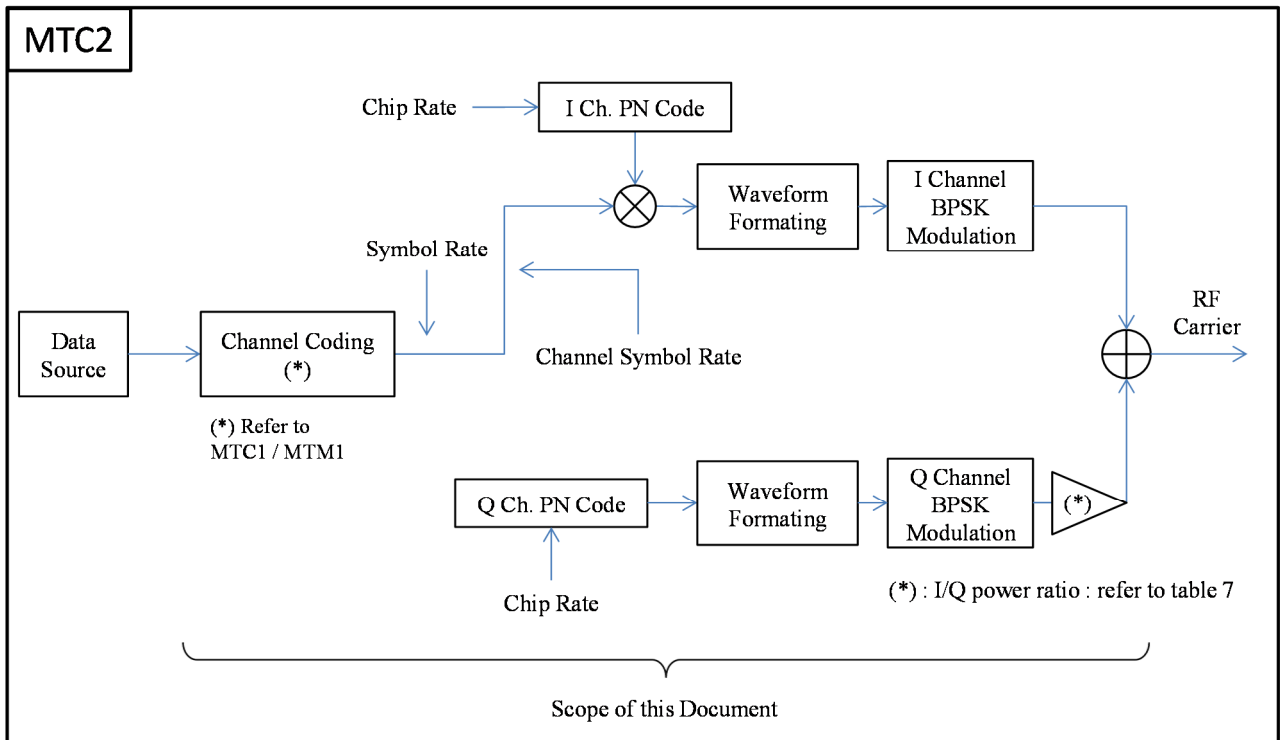

Figure 3: Functional stages of transmit chain for spread spectrum modulation MTC2

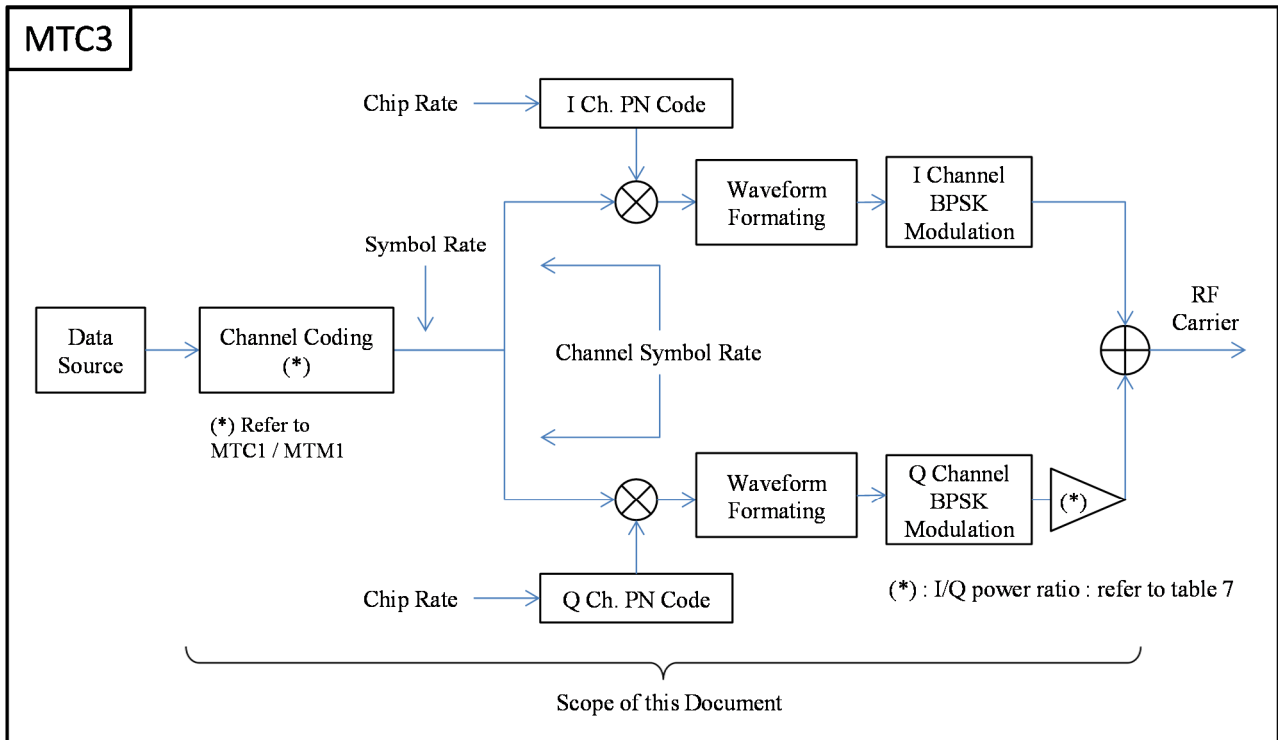

Figure 4: Functional stages of transmission chain for spread spectrum modulation MTC3

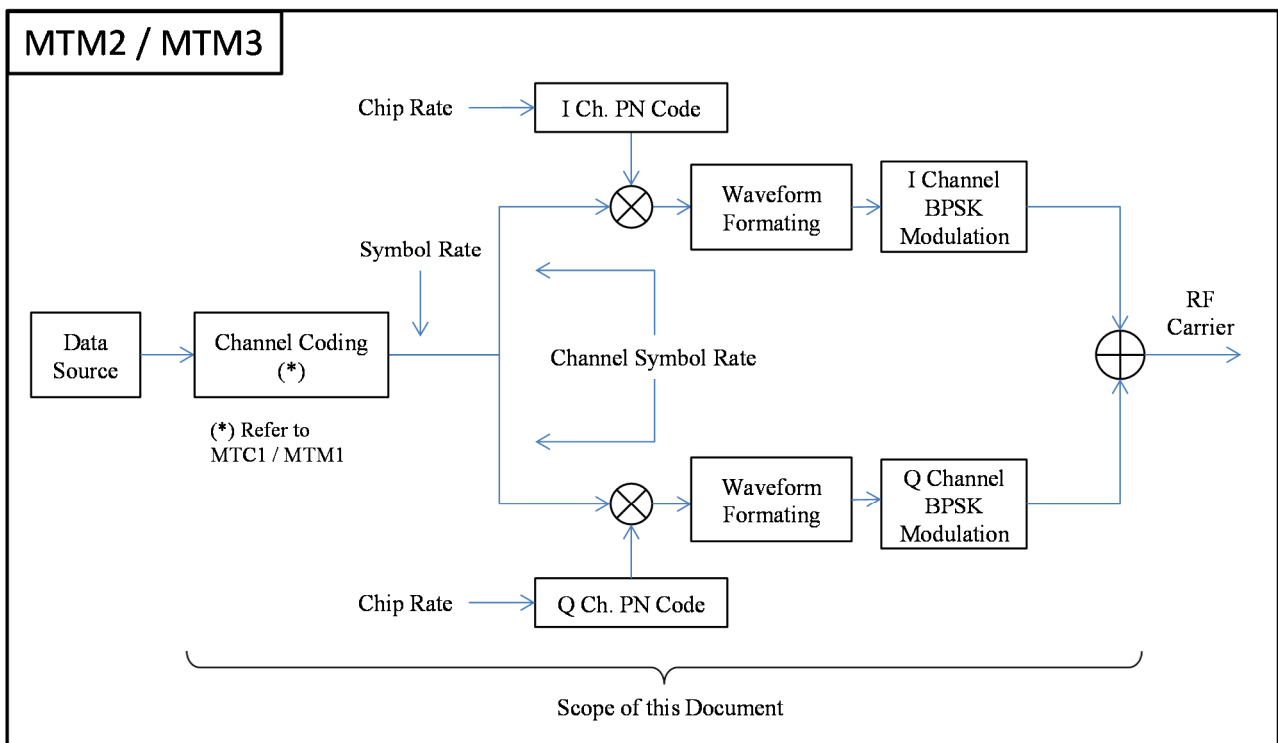

Figure 5: Functional stages of transmission chain for spread spectrum modulation MTM2/MTM3

3.2 Abbreviations

For the purposes of the present document, the following abbreviations apply:

ASN	Abstract Syntax Notation
BCH	Bose-Chaudhuri-Hocquenghem
BPSK	Binary Phase Shift Keying
BSS	Broadcast Satellite Service
CDMA	Code Division Multiple Access
CEC	Co-located Equivalent Capacity
CLTU	Command Link Transmission Unit
CMM	Carrier Modulation Modes
COM	Communication channel
CW	Continuous Wave
dBc	decibels relative to the carrier
dBsd	decibels relative to the maximum value of power spectral density
DSSS	Direct Sequence Spread Spectrum
EOL	End of Life
ESA	European Space Agency
FEC	Forward Error Correction
FM	Frequency Modulation
FSS	Fixed Satellite Service
GEO	Geosynchronous Earth Orbit
GSO	Geostationary Satellite Orbit
HP	Hosted Payload
HPA	High Power Amplifier
HPIU	Hosted Payload Interface Unit
HPM	Hosted Payload Management
ITU	International Telecommunication Union
LDPC	Low Density Parity Check
LEOP	Launch and Early Orbit Phase
LSB	Least Significant Bit
MAI	Multiple Access Interference
MSB	Most Significant Bit
MSS	Mobile Satellite Service
MTC1	TeleCommand Mode 1
MTC2	TeleCommand Mode 2
MTC3	TeleCommand Mode 3
MTM1	TeleMetry Mode 1
MTM2	TeleMetry Mode 2
MTM3	TeleMetry Mode 3
NA	Not Applicable
NGSO	Non Geostationary Satellite Orbit
NRZ	Non-Return to Zero
NRZ-L	Non Return to Zero-Level
NRZ-M	Non Return to Zero-Mark
OQPSK	Offset Quaternary Phase Shift Keying
PCM	Pulse Coded Modulation
PDF	Probability Density Function
PLOP	Physical Layer Operating Procedures
PM	Phase Modulation
PN	Pseudo Noise
PSD	Power Spectral Density
QPSK	Quaternary Phase Shift Keying
RF	Radio Frequency
RG	Ranging
SOS	Space Operation Service
SP-L	Split Phase-Level (alias Bi- Φ -Level or Manchester encoded)
sps	symbol per second
SRRC	Square Root Raised Cosine
SS	Spread Spectrum

TC TeleCommand
 TCR Telemetry, Command and Ranging
 TM TeleMetry
 UQPSK Unbalanced Quaternary Phase Shift Keying
 w.r.t with respect to
 XML eXtensible Mark-up Language

4 Modulation Requirements

4.1 General

The generic system functional block diagram is shown in figure 6. Modulation modes and configurations are shown in table 1.

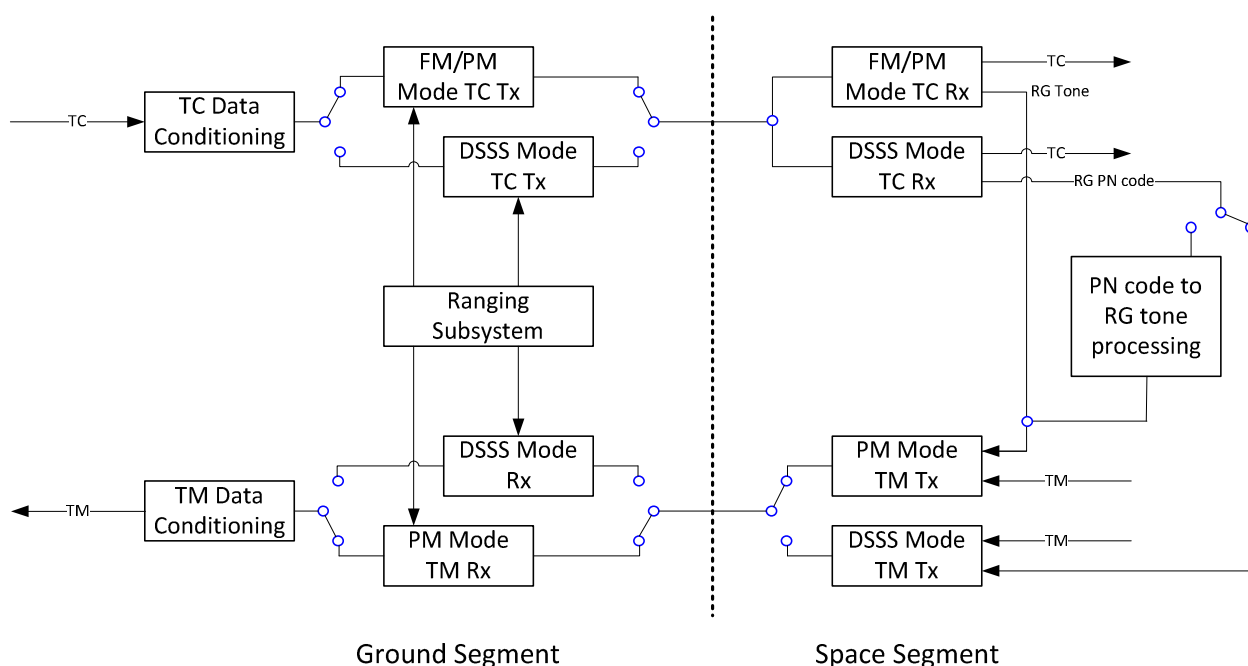

Figure 6: Generic system functional block diagram

Table 1: Modulation modes and potential configurations

	All FM/PM mode	All spread mode	Hybrid mode
Uplink	MTC1: PCM/BPSK/FM or PCM/BPSK/PM or PCM(SP-L)/PM	MTC2/MTC3: PCM/SRRC-UQPSK	MTC2/MTC3: PCM/SRRC-UQPSK
Downlink (with ranging (see note): requires uplink present)	MTM1: PCM/BPSK/PM	MTM2: PCM/SRRC-OQPSK (PN code clock/epoch sync to uplink clock/epoch)	MTM1: PCM/BPSK/PM
Downlink (without ranging: can operate without uplink present)	MTM1: PCM/BPSK/PM	MTM3: PCM/SRRC-OQPSK (PN code clock/epoch independent of uplink clock/epoch)	MTM1: PCM/BPSK/PM
NOTE: Further definition of ranging signals is given in following clauses.			

In order to retain backward compatibility with existing ground networks and to allow simple operation during LEOP, in addition to the more recent Spread Spectrum modes, the existing FM/PM modulation modes are kept. It is envisaged that telecommand and telemetry modulation formats shall be independently configurable, allowing for example the following configuration possibilities (see also annex A for implementations and ETSI TR 101 956 [i.1]):

- all standard mode (as has existed in previous systems) using tone ranging on FM uplink (MTC1) and PM (MTM1) downlink;
- all spread mode (Direct Sequence Spread Spectrum: DSSS) using PN spreading code regenerative ranging on suppressed carrier up-and down-links (MTC2/MTC3 and MTM2);
- hybrid mode using PN spreading code ranging on suppressed carrier DSSS uplink (MTC2), and tone ranging on PM downlink (MTM1).

On the spread spectrum (DSSS) mode downlink, there are 2 PN code sets defined, for coherent and non-coherent modes (modes MTM2 and MTM3 respectively). The physical partitioning of the functions may not exactly follow that shown in the system functional block diagram. The modulation configuration of the various modes is described in the rest of clause 4. Possible allocation of modes to mission phases is defined in annex A.

On the spread spectrum (DSSS) mode uplink, there are two modes defined: MTC2 and MTC3. MTC2 is the uplink mode from document ETSI EN 301 926 (V1.2.1) [i.2] in 2002. MTC3 is an add-on mode that could be used in case of an aggravated multiple access interference (MAI) environment. MTC2 and MTC3 modulation characteristics along with acquisition and tracking schemes are introduced in clause 4.3.1.

4.2 Frequency and Phase Modulations

4.2.1 Modulating waveforms

The following modulating waveforms are permitted:

- Telemetry (mode MTM1): a sine wave sub carrier, itself BPSK modulated by PCM data.
- Telecommand (mode MTC1): a sine wave subcarrier, itself BPSK modulated by PCM data.

NOTE: Except for SP-L between 8 ksps and 64 ksps (direct modulation).

- Ranging (mode MTC1 + MTM1): an unmodulated sinewave subcarrier or combination of a number of such subcarriers.

4.2.2 PCM waveforms and data rates

The PCM waveform formatting is defined in figure 7.

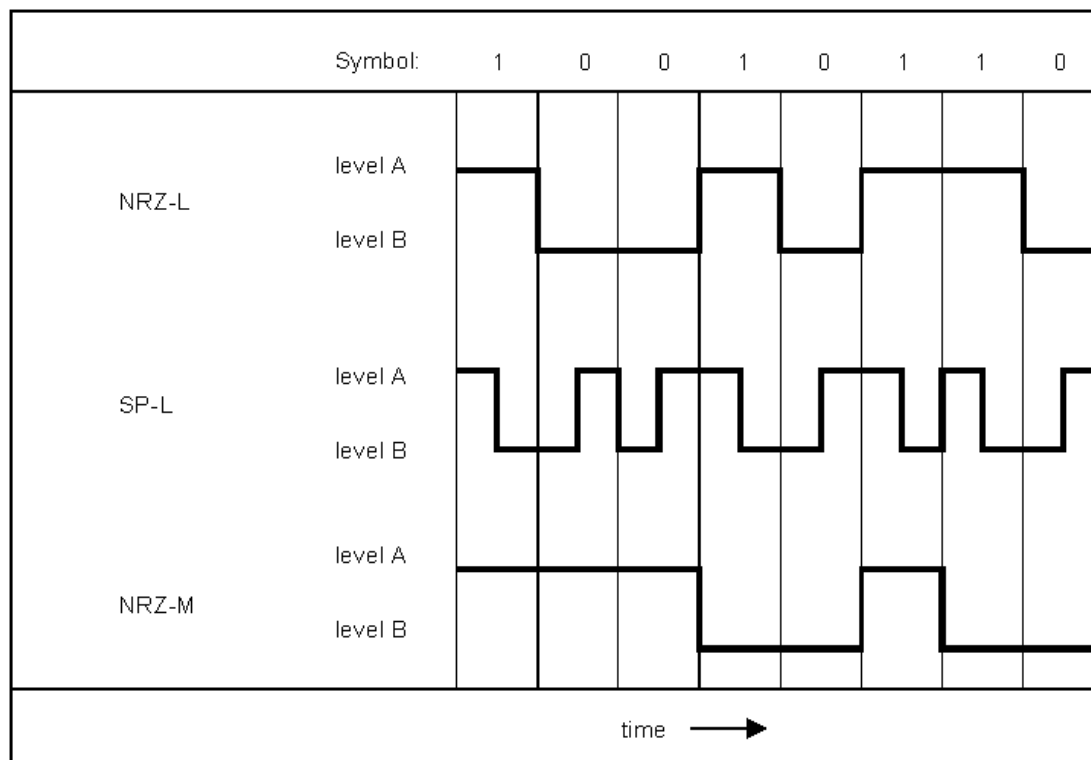

NRZ-L level A signifies symbol "1",
level B signifies symbol "0".

SP-L level A during the first half-symbol followed by level B during the second half-symbol signifies symbol "1",
level B during the first half-symbol followed by level A during the second half-symbol signifies symbol "0".

NOTE: SP-L is also known in literature as bi-phase modulation or Manchester encoding.

NRZ-M level change from A to B or B to A signifies symbol "1",
no change in level signifies symbol "0".

Figure 7: PCM waveforms formatting

PCM data signals shall be limited to the waveforms and symbol rates given in table 2.

Table 2: PCM waveforms and rates

Function	Symbol rate (symbols/s or sps)	PCM waveform	Special requirements
Telecommand (Mode MTC1)	Between 250 sps up to 4 000 sps (see note)	NRZ-L NRZ-M	Using subcarrier modulation
	Between 8 ksps up to 64 ksps	SP-L	Using PCM(SP-L)/PM modulation
Telemetry (Mode MTM1)	Between 1 ksps up to 64 ksps (see note)	NRZ-L NRZ-M SP-L	

NOTE: Coherency between symbols and sub-carrier is required.

4.2.3 Use of subcarriers

The subcarriers and modulating waveforms that shall be used are listed in table 3.

Table 3: Subcarriers used with FM or PM RF carriers

Function	Subcarrier (kHz)	Modulation waveform	Subcarrier waveform
Telecommand (Mode MTC1)	8 or 16 (up to 4 ksps)	NRZ-L, NRZ-M	Sine (up to 4 ksps)
Telemetry (Mode MTM1)	2 to 300 (up to 64 ksps)	NRZ-L NRZ-M SP-L	Sine (up to 64 ksps)
Ranging (Mode MTM1 + MTC1)	2 to 500	None (CW Tone)	Sine

4.2.4 Choice of Subcarrier Frequencies

For telecommand transmission using a subcarrier, only two subcarrier frequencies are permitted.

The subcarrier frequency shall be 8 kHz for all telecommand rates up to 2 000 sps. A 16 kHz subcarrier shall be used only in cases where the 4 000 sps symbol rate is needed or when required by the operator. No subcarrier shall be used for symbol rates above 4 000 sps.

The choice of the ranging and telemetry subcarrier frequencies shall take into account the requirements of:

- carrier acquisition by the ground receivers;
- compatibility between ranging and telemetry;
- occupied bandwidth.

Modulation of subcarriers used for telemetry and telecommand shall be BPSK (for ranging the subcarriers are unmodulated tones).

The following requirements shall be met for TC and TM subcarriers:

- for NRZ-L and NRZ-M signal waveforms, the subcarrier frequency shall be a multiple (integer) of the symbol rate from 4 to 1 024;
- for SP-L signal waveforms, the subcarrier frequency shall be an even integer multiple of the symbol rate from 4 to 1 024;
- at each transition in the PCM formatted waveform, the subcarrier shall be reversed in phase;
- the transitions in the PCM formatted waveform shall coincide with a subcarrier zero crossing to within $\pm 2,5\%$ of a subcarrier period;
- at all times, for more than 25 % of a subcarrier period after a phase reversal, the phase of the modulated subcarrier shall be within $\pm 5^\circ$ of that of a perfect BPSK signal;
- for NRZ-L and SP-L waveforms, the beginning of the symbol intervals shall coincide with a positive-going subcarrier zero crossing for symbols "1" and with a negative-going zero crossing for symbols "0";
- for NRZ-M waveforms, the beginning of the symbol intervals shall coincide with a subcarrier zero crossing.

4.2.5 Uplink Carrier Frequency Deviation (Frequency Modulation)

The FM deviation (modulation depth) is stated in table 4.

Table 4: FM uplink frequency deviation

Function	Deviation (kHz)
Telecommand (PCM/BPSK/FM) (Mode MTC1)	Up to ± 400 kHz
Ranging Earth-to-space (FM) (Mode MTC1) (total deviation of all simultaneous major and minor tones)	Up to ± 400 kHz

4.2.6 Uplink PM Modulation Index

Minima and maxima of the modulation index are stated in table 5.

Table 5: PM modulation index

Function	Minimum (radians peak)	Maximum (radians peak)
Telecommand (PCM/BPSK/PM) (Mode MTC1)	0,2	1,4
Telecommand (SP-L) (Mode MTC1)	0,2	1,0
Ranging Earth-to-Space (PM) (mode MTC1)	0,2	1,4

4.2.7 Downlink PM Modulation Index

Minima and maxima of the modulation index are stated in table 6.

Table 6: PM modulation index

Function	Minimum (radians peak)	Maximum (radians peak)
Telemetry (PCM/BPSK/PM) (Mode MTM1)	0,1	1,5
Ranging Space-to-Earth (PM) (Mode MTM1)	0,01	1,5
NOTE: Effective ranging modulation index considering the power sharing due to re-modulated uplink noise.		

4.2.8 Sense of Modulation

A positive going video signal (modulated TM subcarrier and/or ranging) shall result in an advance of the phase of the downlink Radio Frequency carrier.

4.2.9 Data Transition Density

- To ensure recovery of the symbol clock by the ground demodulators, the transition density in the transmitted PCM waveform shall not be less than 125 in any sequence of 1 000 consecutive symbols.
- To ensure recovery of the symbol clock by the ground demodulators, the maximum string of either ones or zeros shall be limited to 64 symbols.
- When the specifications in a) and b) are not ensured for the channel by other methods, a pseudo-randomizer in conformance with [2], section 9 shall be used.

4.2.10 Modulation Linearity

The phase deviation, as a function of the video voltage applied to the modulator, shall not deviate from the ideal linear response by more than ± 3 % of the instantaneous value for deviations up to 1,5 rad peak.

4.2.11 Residual Amplitude Modulation

Residual amplitude modulation of the phase modulated RF signal shall be less than 2 %.

4.2.12 Residual Carrier, Out-of-band Emission and Discrete Spectral Lines

- The residual power in the modulated carrier shall be greater than -15 dBc for space-Earth and -10 dBc for Earth-space links.
- Discrete lines in the unmodulated transmitted RF signal spectrum, caused by baseband or RF bandwidth limitations, non-linearity of the channel, digital implementation of the frequency synthesis, or any other effects shall be less than -45 dBc inside the occupied bandwidth.
- Modulation shall not result in the introduction of lines with power greater than -30 dBc in the occupied bandwidth.
- Modulation shall not result in the introduction of discrete spectral lines greater than -30 dBc in the frequency range of $\pm 2,67 \times 10^{-5} \times f_c$ around the carrier at frequency f_c .
- For the case of filtered SP-L modulation, the spectral lines at the even multiples of the symbol rate shall not be higher than -20 dBc.
- The out-of-band emission due to the modulation shall comply with the following emission mask.

Space Services Permitted Unwanted Emission

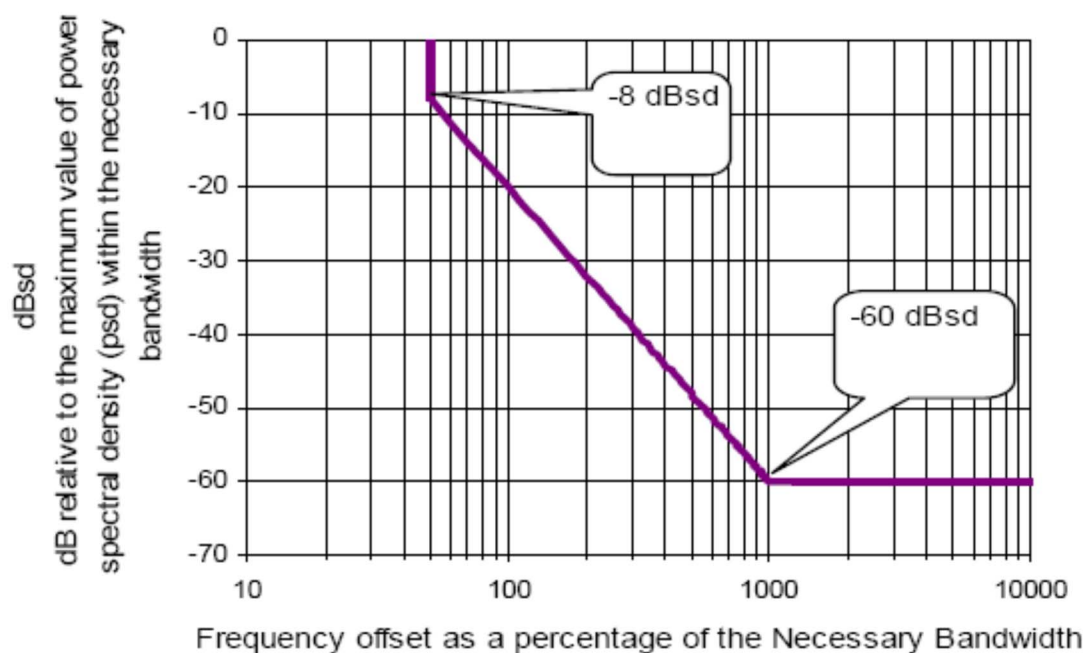

Figure 8: Out-of-Band Emission Mask

The mask is interpreted as follows:

- dBsd is dB attenuation in a 4 kHz bandwidth, relative to the maximum power in any 4 kHz band within the necessary bandwidth.
- For frequencies offset from the assigned frequency less than the 50 % of the necessary bandwidth (B_n), no attenuation is required.

- At a frequency offset equal to 50 % of the necessary bandwidth, an attenuation of at least 8 dB is required.
- Frequencies offset more than 50 % of the necessary bandwidth should be attenuated by the following mask:

$$40 \cdot \log\left(\frac{2 \cdot |f_d|}{B_n}\right) + 8 \text{ (dBsd)}$$

where f_d is the frequency displaced from the center of the emission bandwidth.

4.3 Spread Spectrum Modulation

4.3.1 General

The spread modulation formats shall be:

- Telecommand Uplink: Square Root Raised Cosine filtered Unbalanced QPSK (SRRC-UQPSK).
- Telemetry Downlink: SRRC filtered Offset QPSK (SRRC-OQPSK).

The spread modulation modes shall be as follows:

- Mode MTC2: spread spectrum telecommand uplink.
- Mode MTC3: spread spectrum telecommand uplink (alternative PN code structure).
- Mode MTM2: spread spectrum telemetry downlink, coherent mode (long PN code).
- Mode MTM3: spread spectrum telemetry downlink, non-coherent mode (short PN code).

The Spread Spectrum modulation characteristics shall be as defined in table 7. The modulation modes listed shall be available for communications between the Spacecraft and the Earth Terminal for a range of data rates. Symbol rates referred to in the present document include the channel coding overhead whenever channel coding is applied. The Symbol rate shall be selected depending on requirements, link budget and multiple access capabilities. Modulator imperfections are defined in annex C.

Table 7: Spread spectrum link modulation modes

	Telecommand link, Mode MTC2	Telecommand link, Mode MTC3	Coherent telemetry link, Mode MTM2	Non-coherent telemetry link, Mode MTM3
Symbol Rate	In the range 0,1 ksp/s - 300 ksp/s and < 10 % of spreading code rate Baseline values: 500×2^n sp/s $n = 0$ to 9	In the range 0,1 ksp/s - 300 ksp/s and < 10 % of spreading code rate	In the range 0,1 ksp/s - 300 ksp/s and < 10 % of spreading code rate	In the range 0,1 ksp/s - 300 ksp/s and < 10 % of spreading code rate
Channel Symbol rate on I channel (sp/s)	=Symbol Rate	=Symbol Rate	=Symbol Rate (Same symbols on both channels)	=Symbol Rate (Same symbols on both channels)
Channel Symbol rate on Q channel (sp/s)	PN code only	= I channel symbol rate (same symbols on both channels)	= I channel symbol rate (Same symbols on both channels)	= I channel symbol rate (Same symbols on both channels)
Data format	NRZ-L NRZ-M	NRZ-L, NRZ-M	NRZ-L NRZ-M	NRZ-L NRZ-M
PN code family I channel	Gold code	Acquisition: Gold code, Tracking: truncated m-sequence or truncated Gold sequence	Truncated m-sequence	Gold code
PN Code length I channel	$2^n - 1$ $n = 9$ to 12	Acquisition $2^n - 1$, $n = 9$ to 12 Tracking $(2^n - 1) \times 2^m$, $n = 9$ to 12, $m = 6$ to 12	$(2^n - 1) \times 2^m$ $n = 9$ to 12 $m = 6$ to 12	$2^n - 1$ $n = 9$ to 12

	Telecommand link, Mode MTC2	Telecommand link, Mode MTC3	Coherent telemetry link, Mode MTM2	Non-coherent telemetry link, Mode MTM3
Code I epoch reference	None	None	Received Q code of MTC2	None
PN code family Q channel	Truncated m-sequence or truncated Gold sequence	Truncated m-sequence or truncated Gold sequence	Truncated m-sequence or truncated Gold sequence	Gold code
PN Code length Q channel	$(2^n-1) \times 2^m$ n = 9 to 12 m = 6 to 12	$(2^n-1) \times 2^m$ n = 9 to 12 m = 6 to 12	$(2^n-1) \times 2^m$ n = 9 to 12 m = 6 to 12	2^n-1 n = 9 to 12
Code Q epoch reference	I code	I code	x + 1/2 chips (x > 20 000) Delay w.r.t I ch of MTM2	1/2 chip delay w.r.t I of non-coherent mode return link
Spreading code rate (Mc/s)	In the range 0,5 to 10 Mcps Baseline values: 1,023 Mcps and 3,069 Mcps	In the range 0,5 to 10 Mcps	Identical to Received code	In the range 0,5 to 10 Mcps
Modulation	SRRC-UQPSK	Acquisition: SRRC- UQPSK Tracking: SRRC-QPSK	SRRC-OQPSK	SRRC-OQPSK
I/Q power ratio	Between 10:1 and 1:1	Acquisition: between 10:1 and 1:1 Tracking: 1:1	1:1	1:1
Ranging service possible	Yes	Yes	Yes	No
NOTE 1: Data formats NRZ-L and NRZ-M are defined in clause 4.2.2, figure 7.				
NOTE 2: The term 'Gold code' is used to indicate codes with controlled and limited cross-correlation. Strictly speaking for 'n' or 'm' being a multiple of 4 one cannot define Gold codes (3-value cross-correlation). However, one can identify and define 'good' codes (5-value cross-correlation codes).				

The Telecommand uplink signal in mode MTC2 shall be a spread spectrum SRRC-UQPSK modulated signal with:

- during acquisition, a short PN code on the I Channel and a long PN code on the Q channel, no data are transmitted during this phase;
- once locked, during tracking phase the data are added and carried by I Channel.

The Telecommand uplink signal in mode MTC3 shall be a spread spectrum SRRC-QPSK modulated signal with:

- during acquisition, a short PN code on the I Channel and a long PN code on the Q channel without data and with I/Q power ratio up to 10 (UQPSK);
- during tracking phase, a long PN code is applied on I channel, synchronized with Q channel one and with I/Q power ratio equal to 1 (QPSK). No change on Q channel.

Tracking phase begins with a two-section acquisition sequence. The first is a constant data (unmodulated) section which provides for detection of the I code change. The second section is modulated with alternating data which provides for symbol clock acquisition.

See detailed schematic on figure 9.

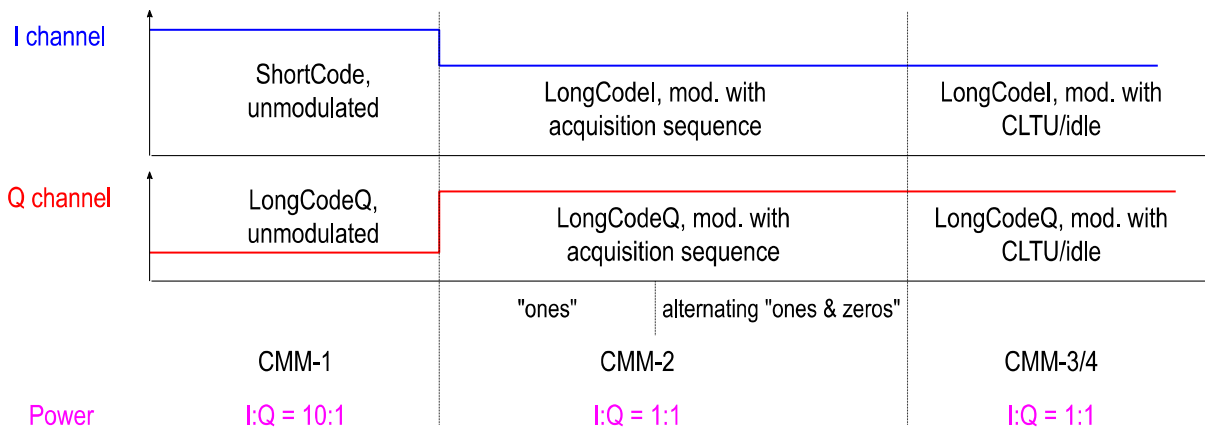

Figure 9: MTC3 mode scheme

The coherent mode telemetry downlink signal in mode MTM2 shall be a spread spectrum SRRC-OQPSK modulated signal with data on the Q channel and on the I channel. MTM2 supports ranging by transmission of a long PN code on the downlink I channel synchronized to the code received on the mode MTC2/MTC3 uplink Q channel. A delayed version of this code is transmitted on the downlink Q channel.

Mode MTM3 shall be a spread spectrum SRRC-OQPSK modulated signal with the data on the Q channel and on the I channel. MTM3 does not support ranging. A short (Gold) PN code is transmitted on the I channel and a half chip delayed Gold code is transmitted on the Q channel.

For all spread PN coded transmissions, the data shall be modulo-2 added to the PN code and any pulse shaping (i.e. SRRC) performed before being applied to the carrier modulator. Alignment of PN sequence epoch and symbol transitions may be enforced for the up-link and non-coherent down-link.

4.3.2 Chip Shaping

SRRC Square Root Raised Cosine pulse or chip shaping shall be applied, in order to achieve bandwidth restriction of the transmitted spread spectrum signal.

SRRC filtering is defined in terms of a roll off factor α which has a value between 0 and 1, with the RF bandwidth of the spread spectrum signal given by $(1 + \alpha)R_c$, where R_c is the chip rate.

For the purposes of the present document $\alpha = 0,5$ shall be used, giving an RF bandwidth of $1,5 R_c$.

4.3.3 Out-of-Band Emission and Discrete Spectral Lines

- The out-of-band emission due to the modulation shall comply with the emission mask specified by bullet f) of clause 4.2.12.
- The aggregate of all discrete spectral lines inside the modulated spectrum, whatever their cause, shall be lower than -30 dBc.

4.4 Coherency Properties

In mode MTM1 and MTC1, coherency between symbol rate and sub-carrier is required.

In non-coherent spread mode (MTM3), all of the clocks/carriers shall be derived from references local to the spacecraft and independent of the uplink: downlink RF carrier, TM data clock, PN chip clock and PN Epoch shall be local to the spacecraft. This mode is used whenever the up-link receiver is not locked.

In coherent spread mode (MTM2), the downlink PN code Epoch and chip clock shall be synchronized to the uplink Q channel PN code. However, other downlink clocks/carriers may be local to the spacecraft and independent of the uplink: downlink RF carrier and TM data shall be local to the spacecraft.

5 Requirements on Transmitted Signals

5.1 Frequency Stability

5.1.1 Uplink

In all modes, the on-board receiver shall tolerate:

- A frequency shift due to Doppler effect of 22 ppm (for RF carrier, sub-carrier and data rate).
- A ratio $\frac{\text{Doppler rate}}{\text{Frequency}}$ of 1,7 ppm/s (for RF carrier, sub-carrier and data rate).

The ground contribution to those deviations shall be at least two orders of magnitude lower.

5.1.2 Downlink

The Doppler values to take into account for the downlink shall be identical to uplink.

The stability of the on-board generated RF frequency (for modes MTM1 or MTM2) shall be better than 5 ppm (end of life).

The stability of the on-board generated downlink chip rate (for mode MTM3) shall be better than 5 ppm (end of life).

5.2 Turnaround Frequency Ratio

No turnaround frequency ratio is required between the up and down RF links, since there shall be no coherency between uplink and downlink carriers.

5.3 Polarization

Polarization is operator and mission phase dependent, and its definition is beyond the scope of the present document.

5.4 Phase Noise

5.4.1 Ground Transmitter

The single-sided ($2 L(f)$) phase noise measured on a unmodulated carrier between 10 Hz and 1 MHz around the carrier shall be less than:

Table 8

Frequency w.r.t. the carrier (Hz)	Phase Noise power density (dBc/Hz)
10	-35
100	-63
1 000	-80
10 000	-92
100 000	-105
1 000 000	-115

5.4.2 On-board Transmitter

The single-sided ($2L(f)$) phase noise measured on a unmodulated carrier between 10 Hz and 100 kHz around the carrier shall be less than:

Table 9

Frequency w.r.t. the carrier (Hz)	Phase Noise power density (dBc/Hz)
10	-40
100	-57
1 000	-65
10 000	-70
100 000	-90

Linear interpolation shall be applied between above frequencies.

The integrated phase noise between 10 Hz and 100 kHz shall be lower than 5° rms.

6 Link Acquisition Requirements

6.1 Link Acquisition Performance

The acquisition time of the uplink signal shall be less than 3 seconds for all bands except at Ka band where 5 seconds is allowed. The acquisition success probability shall be greater than 99 %.

For the downlink, the acquisition time of the downlink signal shall be less than 10 seconds, with a success probability greater than 99 %.

No Telecommand data shall be modulated onto the signal for the time interval allowed for PN code acquisition.

All blocks of Telecommand data shall be initiated by a sequence alternating from logic low to logic high and back to logic low for a total duration of 168 Telecommand symbols.

6.2 Physical Layer Operations Procedures

Physical layer operations procedures (PLOPs) shall be as specified in [1]. Carrier modulation modes (CMM) are different for MTC2 and MTC3 as listed in tables 10 and 11.

Table 10: MTC2 Carrier Modulation Modes

CMM-1	Data-unmodulated spread spectrum carrier
CMM-2	Spread spectrum carrier modulated with acquisition sequence; modulation on I and on Q
CMM-3	Spread spectrum carrier modulated with CLTU; modulation on I and on Q
CMM-4	Spread spectrum carrier modulated with idle sequence; modulation on I and on Q
NOTE 1: Spread spectrum carrier means carrier modulated with Gold code with length 2^n-1 , $n = 9$ to 12 , on I and truncated m-sequence with length $(2^n-1) \times 2^m$, $n = 1$ to 9 , $m = 6$ to 12 on Q. I/Q power ratio up to 10:1.	
NOTE 2: The Acquisition Sequence is a data structure forming a preamble which provides for initial symbol synchronization within the incoming stream of detected symbols. The length of the Acquisition Sequence shall be selected according to the communications link performance requirements of the mission, but the preferred minimum length is 16 octets. The length is not required to be an integral multiple of octets. The pattern of the Acquisition Sequence shall be alternating 'ones' and 'zeros', starting with either a 'one' or a 'zero' (see [1]).	

Table 11: MTC3 Carrier Modulation Modes

CMM-1	Data-unmodulated spread spectrum carrier I
CMM-2	Spread spectrum carrier II modulated with acquisition sequence; modulation on I and on Q
CMM-3	Spread spectrum carrier II modulated with CLTU; modulation on I and on Q
CMM-4	Spread spectrum carrier II modulated with idle sequence; modulation on I and on Q
<p>NOTE 1: Spread spectrum carrier I means carrier modulated with Gold code with length 2^n-1, $n = 9$ to 12, on I and truncated Gold code with length $(2^n-1)\times 2^m$, $n = 1$ to 9, $m = 6$ to 12 on Q. I/Q power ratio up to 10:1. Spread spectrum carrier II means carrier modulated with truncated Gold code with length $(2^n - 1) \times 2^m$, $n = 1$ to 9, $m = 6$ to 12 on I and truncated Gold code with length $(2^n - 1) \times 2^m$, $n = 1$ to 9, $m = 6$ to 12 on Q. I/Q power ratio 1:1.</p> <p>NOTE 2: The Acquisition Sequence is a data structure forming a preamble which provides for initial symbol synchronization within the incoming stream of detected symbols. The length of the Acquisition Sequence shall be selected according to the communications link performance requirements of the mission, but the preferred minimum length is 2 times 16 octets. The length is not required to be an integral multiple of octets. The pattern of the Acquisition Sequence shall start with a sequence of constant "ones" followed by alternating 'ones' and 'zeros', starting with either a 'one' or a 'zero' (see [1]).</p>	

7 Coding and Interleaving

7.1 Uplink

The uplink signal may be encoded with one of the following schemes:

- 1) BCH (63,56) as per [1].
- 2) Concatenated Convolutional (inner code) rate 1/2 as per [2], section 3 and BCH (63,56) as per [1].
- 3) Low-Density Parity-Check (LDPC) as per [1].

When sufficient data transition density is not ensured for the channel by other methods, a pseudo-randomizer in conformance with [1], section 5 may be used.

7.2 Downlink

The downlink signal may be encoded with one of the following schemes:

- 1) Convolutional coding rate 1/2 as per [2], section 3.
- 2) Reed-Solomon coding and interleaving as per [2], section 4.
- 3) Turbo Coding as per [2], section 5.
- 4) LDPC as per [2], section 7.
- 5) Concatenated Convolutional (inner code) rate 1/2 as per [2], section 3 and Reed-Solomon coding and interleaving (outer code) as per [2], section 4.

When the data transition specifications in clause 4.2.9 bullet a) and b) are not ensured for the channel by other methods, a pseudo-randomizer in conformance with [2], section 9 may be used.

Annex A (informative): Operational Configuration

A.1 Introduction

Communications satellites face different radio-frequency environments, depending on mission phase. There are up to 5 main different mission phases to consider: LEOP phase, transfer (only for satellites with electric orbit raising), drift orbit, nominal on station phase and emergency on station phase.

Depending of the on-board implementation of the standard, spread spectrum or frequency/phase modulation can be used for uplink or downlink. The aim of this annex is to describe the operational configuration of four different possible implementations of the present document.

Considering that spread spectrum modulation allows fulfilling all the different phase of the missions in most cases, the baseline configuration is:

- Configuration Baseline: on board spread spectrum transponder.

Otherwise, if mission scenario does not allow the use of spread spectrum technique in all phases, such as LEOP, three alternative configurations can be envisaged:

- Configuration Alternative 1: on board dual mode receiver and on board dual mode transmitter.
- Configuration Alternative 2: on board dual mode receiver and phase modulation transmitter.
- Configuration Alternative 3: on board dual mode receiver, phase modulation transmitter and dedicated RG SS transmitter.

A typical frequency plan is shown in figure A.1.

36 MHz channels with center frequency separation of 40,00 MHz

UPLINK : (13,7 GHz to 14,5 GHz)

Vertical polarisation

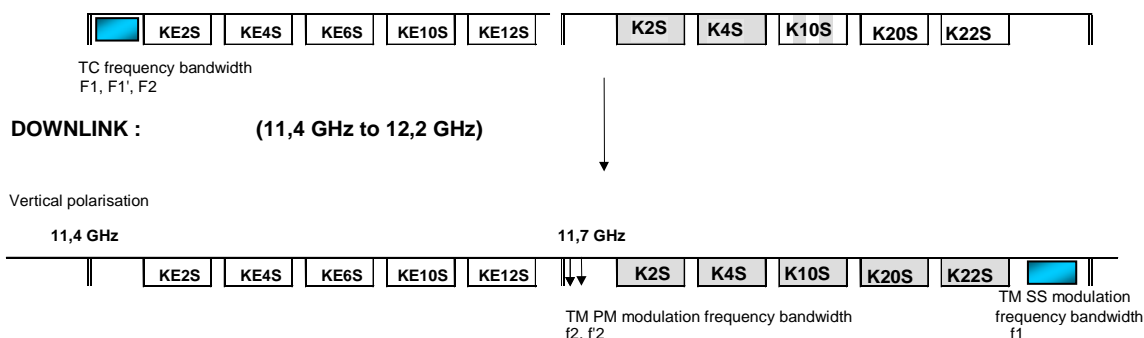

Figure A.1: Typical TCR frequency plan (Ku-Band)

This frequency plan defines various TCR frequencies, but depending of the implementation, some of the frequencies are not used. It has been assumed for the analysis of SS modes (see [i.1]) that any TC-echo effect on the TM signal is negligible.

Uplink:

- F2 is the SS frequency;
- F1 and F1' are in the same bandwidth as F2.

Downlink:

- f_1 is the SS frequency;
- f_2 and f_2' are the PM modulation frequencies, in a different bandwidth than the SS bandwidth.

For each configuration below, the modulation mode (MTC1, MTC2, MTC3, MTM1, MTM2, MTM3) refers to the definition given in clause 5.

A.2 Configuration Baseline: on board spread spectrum transponder

On board the satellite, single mode spread spectrum transponders or separate receivers and transmitters may be used, enabling the demodulation of spread spectrum modulation uplink signal and the modulation of spread spectrum modulation downlink signal.

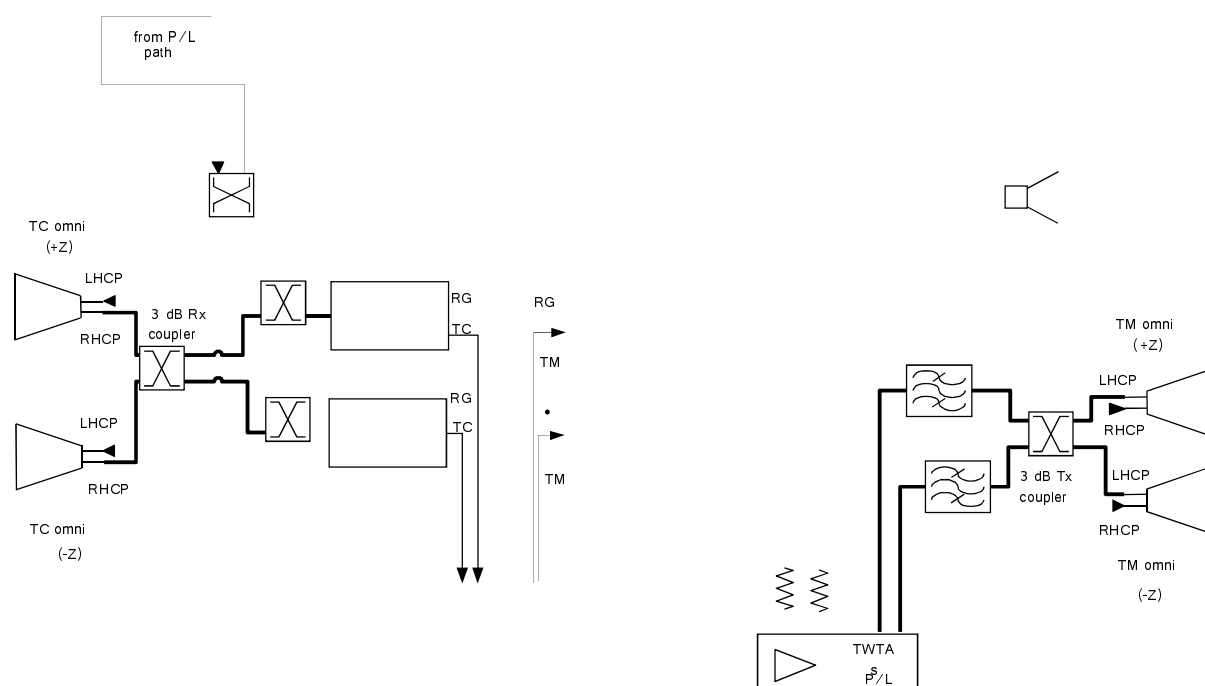

Figure A.2: Baseline Configuration typical TCR/RF architecture

The associated on-board TCR/RF architecture is shown in figure A.2.

The different operational configurations and the associated frequencies are described in table A.1.

Table A.1: Baseline Configuration frequency and modulation assignment

	Beginning of the LEOP	LEOP, apogee phase (low Doppler, possibility of interference with Geo satellites)	Drift orbit (low Doppler, possibility of interference with Geo satellites)	On station nominal	On station emergency
TC		SS (MTC2 or 3), F2		SS (MTC2 or 3), F2	SS (MTC2 or 3), F2
TM		SS (MTM2 or 3), f1		SS (MTM2 or 3), f1	SS (MTM2 or 3), f1
RG		Same as TC/TM		Same as TC/TM	Same as TC/TM

A.3 Configuration Alternative 1: on board dual mode receiver and on board dual mode transmitter

On board the satellite, a dual mode receiver may be used, enabling the demodulation of either spread spectrum or frequency/phase modulation signal (both demodulations are done in parallel but only one is successful, depending of the modulation of the uplink signal). Dual mode transmitters (or two different transmitters, one for PM and one for SS modulation) are used for the downlink.

The receiver and the transmitter simultaneously use spread spectrum in Spread Spectrum mode, and simultaneously use frequency/phase modulation in Frequency/phase Mode (frequency option only on receiver).

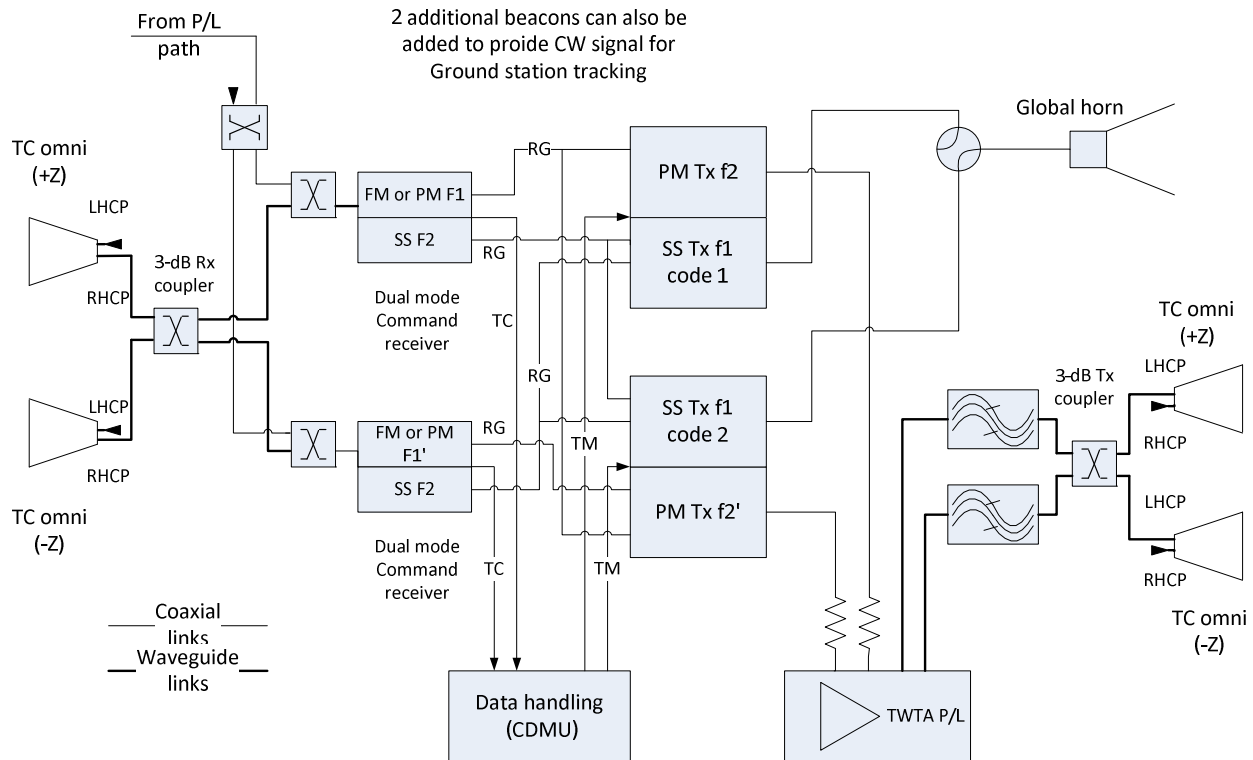

Figure A.3: Configuration 1 typical TCR/RF architecture

The associated on-board TCR/RF architecture is shown in figure A.3.

The different operational configurations and the associated bandwidth are described in table A.2.

Table A.2: Configuration 1 frequency and modulation assignment

	Beginning of the LEOP	LEOP, apogee phase (low Doppler, possibility of interference with Geo satellites)	Drift orbit (low Doppler, possibility of interference with Geo satellites)	On station nominal	On station emergency
TC	SS (MTC2 or 3), F2 or FM/PM (MTC1), F1 or F'1 (see note 3)			SS (MTC2 or 3), F2	SS (MTC2 or 3), F2 or FM/PM (MTC1), F1 or F'1 (see note 3)
TM	SS (MTM2 or 3), f1 or PM (MTM1), f2 or/and f'2 (see note 3)			SS (MTM2 or 3), f1	SS (MTM2 or 3), f1 or PM (MTM1), f2 or/and f'2 (see note 3)
RG	SS up F2, SS down f1 (see note 2) or up MTC1 F1 or F'1, down PM (MTC1) (see note 3)			Same as TC/TM (see note 2)	SS up F2, SS down f1 (see note 2) or up MTC1 F1 or F'1, down PM (MTC1) (see note 3)
NOTE 1: TC and RG can be done simultaneously, depending of RF link budget margin and compatibility between RG tones and TC sub-carrier.					
NOTE 2: TC and RG can be done simultaneously.					
NOTE 3: MTC2 probation phase or ground station incompatibility.					

Note that for the emergency:

- it may be necessary to command sequentially each satellite of a fleet of collocated satellites using the same bandwidth;
- it may be necessary to foresee for the downlink an additional bandwidth ("emergency bandwidth"), distinct from the nominal TM bandwidth.

A.4 Configuration Alternative 2: on board dual mode receiver and phase modulation transmitter

On board the satellite, a dual mode receiver may be used, enabling the demodulation of either spread spectrum or frequency/phase modulation signal (both demodulations are done in parallel but only one is successful, depending of the modulation of the uplink signal). Phase modulation transmitters are used for the downlink, whatever the mission phase of the satellites. A specific process (see annex B) enables the transformation of a PN code into a RG tone, so that for certain mission phases, SS modulation can be used for the uplink (including RG) while Phase modulation is used for the downlink.

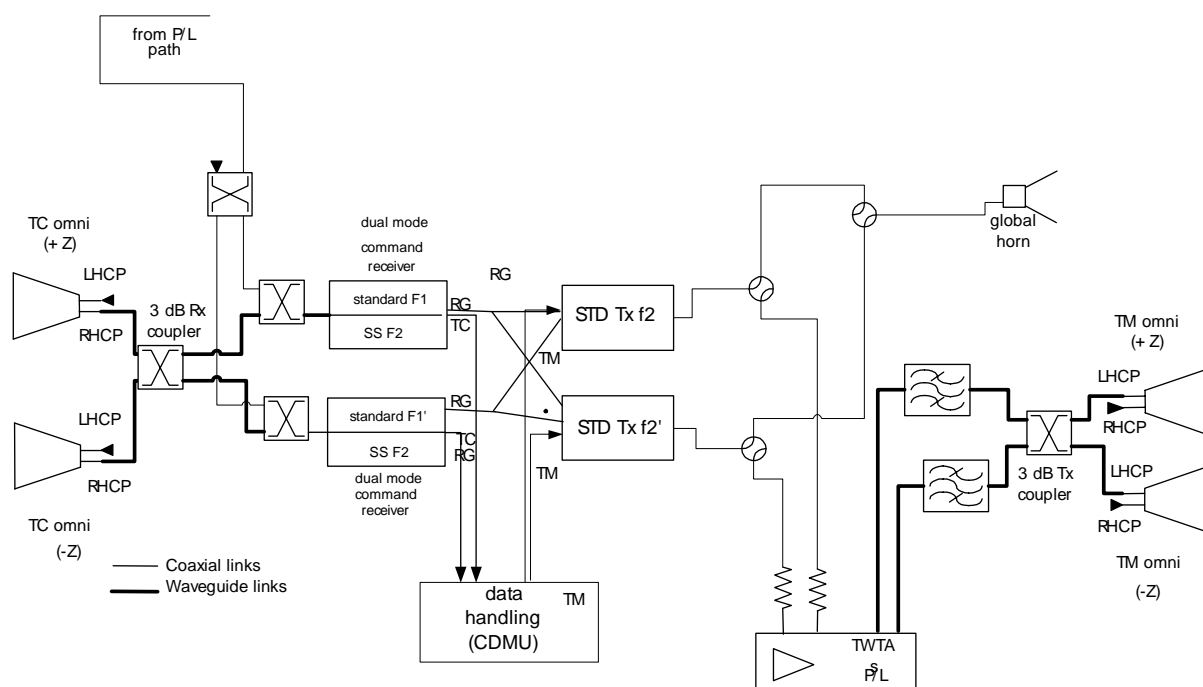

Figure A.4: Configuration 2 typical TCR/RF architecture

The associated on-board TCR/RF architecture is presented in figure A.4.

The different operational configurations and the associated bandwidth are described in table A.3.

Table A.3: Configuration 2 frequency and modulation assignment

	Beginning of the LEOP	LEOP, apogee phase (low Doppler, possibility of interference with Geo satellites)	Drift orbit (low Doppler, possibility of interference with Geo satellites)	On station nominal	On station emergency
TC		SS (MTC2), F2 or FM/PM (MTC1), F1 or F'1 (see note 2)		SS (MTC2), F2	SS (MTC2), F2 or FM/PM (MTC1), F1 or F'1 (see note 2)
TM		PM (MTM1), f2 or/and f'2		PM (MTM1), f2 or/and f'2	PM (MTM1), f2 or/and f'2
RG		Same as TC/TM (standard or hybrid RG) (see note 1)		Same as TC/TM (hybrid RG) (see note 1)	Same as TC/TM (standard or hybrid RG) (see note 1)

NOTE 1: TC and RG can be done simultaneously.

NOTE 2: MTC2 probation phase or ground station incompatibility.

Note that for the emergency:

- it may be necessary to command sequentially each satellite of a fleet of collocated satellites using the same bandwidth;
- no additional bandwidth ("emergency bandwidth") is required for the emergency downlink.

A.5 Configuration Alternative 3: on board dual mode receiver, phase modulation transmitter and dedicated RG SS transmitter

On board the satellite, a dual mode receiver may be used, enabling the demodulation of either spread spectrum or frequency/phase modulation signal (both demodulations are done in parallel but only one is successful, depending of the modulation of the uplink signal). Phase modulation transmitters are used for the downlink TM, whatever the mission phase of the satellites. Concerning the RG, a dedicated SS transmitter is used each time SS RG is used for the uplink.

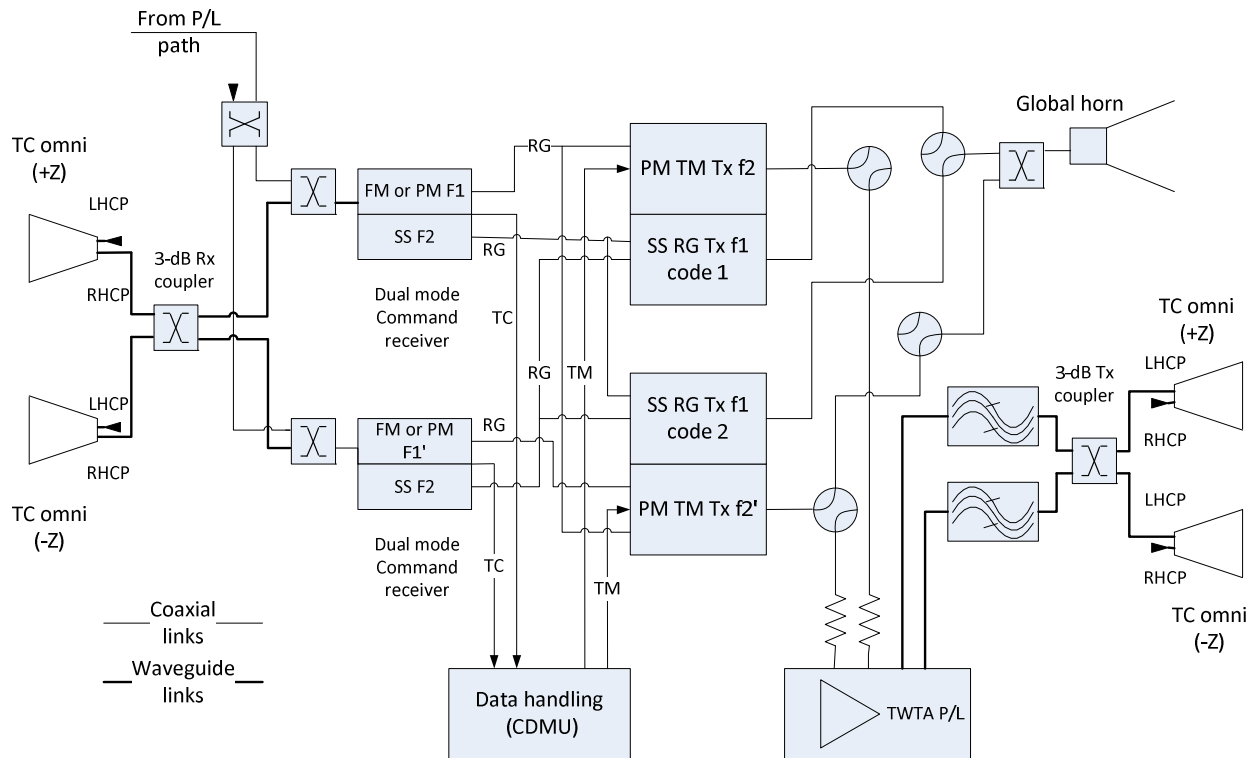

Figure A.5: Configuration 3 typical TCR/RF architecture

The associated on-board TCR/RF architecture is presented in figure A.5.

The different operational configurations and the associated bandwidth are described in table A.4.

Table A.4: Configuration 3 frequency and modulation assignment

	Beginning of the LEOP	LEOP, apogee phase (low Doppler, possibility of interference with Geo satellites)	Drift orbit (low Doppler, possibility of interference with Geo satellites)	On station nominal	On station emergency
TC	SS (<i>MTC2</i>), F2 or FM/PM (<i>MTC1</i>), F1 or F'1 (see note 4)			SS (<i>MTC2</i>), F2	SS (<i>MTC2</i>), F2 or FM/PM (<i>MTC1</i>), F1 or F'1 (see note 4)
TM	PM (<i>MTM1</i>), f2 or/and f'2			PM (<i>MTM1</i>), f2 or/and f'2	PM (<i>MTM1</i>), f2 or/and f'2
RG	SS up F2, SS down f1 (see notes 2 and 3) or up MTC1 F1 or F'1, down PM (<i>MTC1</i>) (see note 4)			SS up F2, SS down f1 (see notes 2 and 3)	SS up F2, SS down f1 (see notes 2 and 3) or up MTC1 F1 or F'1, down PM (<i>MTC1</i>) (see note 4)
NOTE 1: TC and RG can be done simultaneously, depending of RF link budget margin and compatibility between RG tones and TC sub-carrier.					
NOTE 2: TC and RG can be done simultaneously.					
NOTE 3: The modulation used for RG is identical to <i>MTM2</i> (see clause 5) except that no TM data is down linked.					
NOTE 4: <i>MTC2</i> probation phase or ground station incompatibility.					

Note that for the emergency:

- it would be necessary to command sequentially each satellite of a fleet of collocated satellites using the same bandwidth;
- it would be also necessary for the system to foresee 2 downlink bandwidths, one for SS RG, and one for PM modulation TM&RG.

A.6 Configuration Alternative 4: on board dual mode multi-channel receiver and on board dual mode transmitter (for hosted payload management)

As an alternate solution to the baseline configuration depicted on clause A.1, in case more than one hosted payload is embarked, the baseline architecture as per figure A.6 would be applied and a set of multi channels receivers along with a Hosted Payload Interface Unit (HPIU) would be used for the hosted payloads TM/TC links.

In case main operator and hosted payloads users agree to share part of the architecture, hosted payloads TM/TC links can also be managed by the same transponder than the main operator with a unique pair of multi-channel SS receivers and a unique pair of mono-channel SS transmitters.

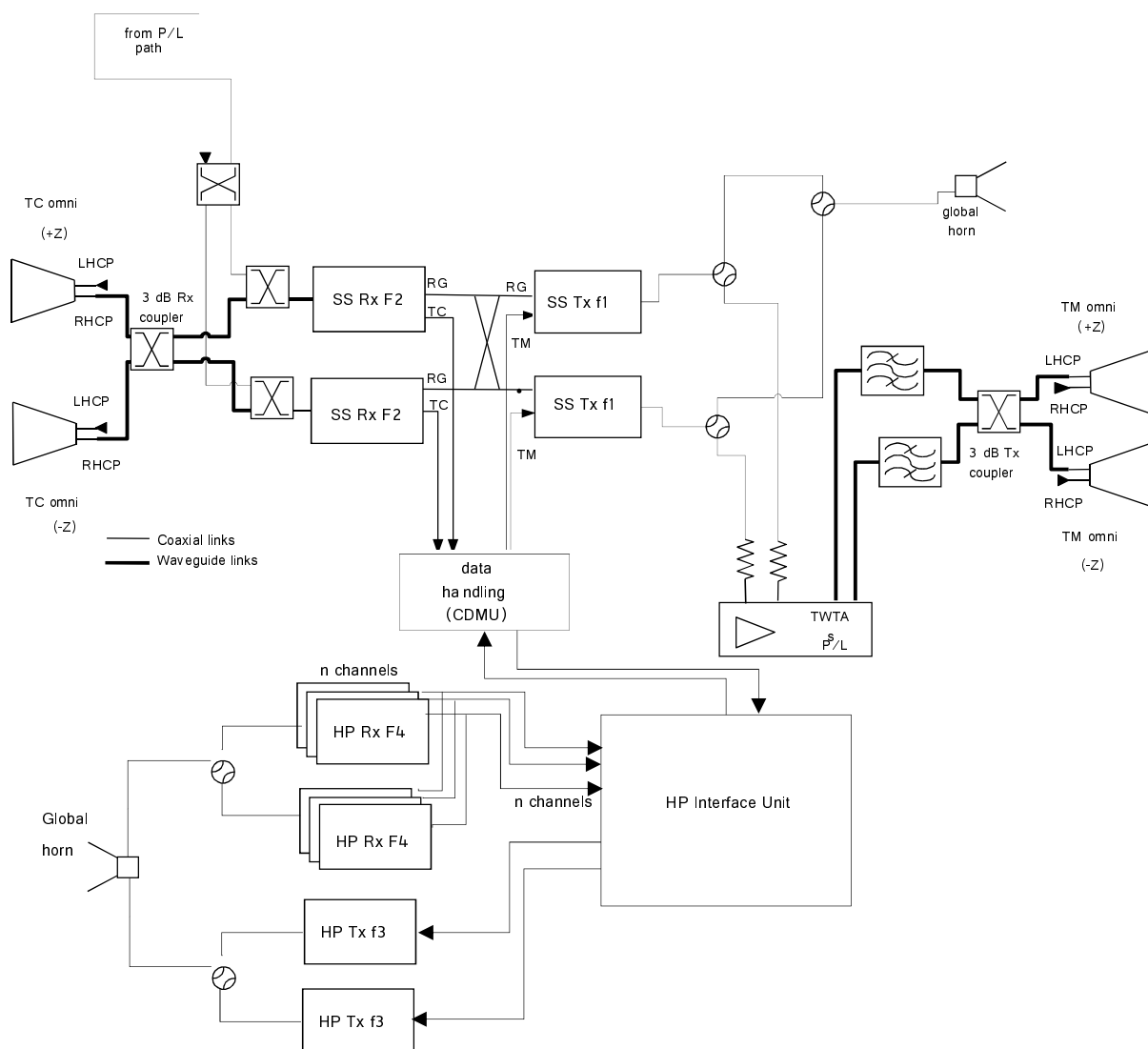

Figure A.6: Baseline Configuration typical TCR/RF architecture

The associated on-board TCR/RF architecture is shown in figure A.6.

The different operational configurations and the associated bandwidth are described in table A.5.

Table A.5: Configuration 4 frequency and modulation assignment

	Beginning of the LEOP	LEOP, apogee phase (low Doppler, possibility of interference with Geo satellites)	Drift orbit (low Doppler, possibility of interference with Geo satellites)	On station nominal	On station emergency
TC		SS (MTC2 or 3), F2		SS (MTC2 or 3), F2 for operator; F4 for HP	SS (MTC2 or 3), F2 for operator; F4 for HP
TM		SS (MTM2 or 3), f1		SS (MTM2 or 3), f1 for operator; f3 for HP	SS (MTM2 or 3), f1 for operator; f3 for HP
RG		Same as TC/TM; NA for HP		Same as TC/TM; NA for HP	Same as TC/TM; NA for HP

NOTE: Hosted payloads TM/TC links are only used on station.

Annex B (informative): Hybrid Ranging process description

B.1 Introduction

The hybrid RG process enables the use of spread spectrum RG for the uplink, and the use of standard RG tone for the downlink.

B.2 Presentation

For the uplink, a RG PN code is transmitted to the satellite, in accordance with the standardized modulation of clause 4.

The satellite receives the uplink spread spectrum signal (PN code) and uses the clock of this PN code to generate some synchronized RG tones. The phase of the tone corresponds to the beginning of the PN code, and there is an integer multiple of tone periods during the PN code epoch. This ranging is transmitted to the ground by using PM modulation, and the ground baseband unit measures the delay between this tone and the original transmitted PN code (see figure B.1).

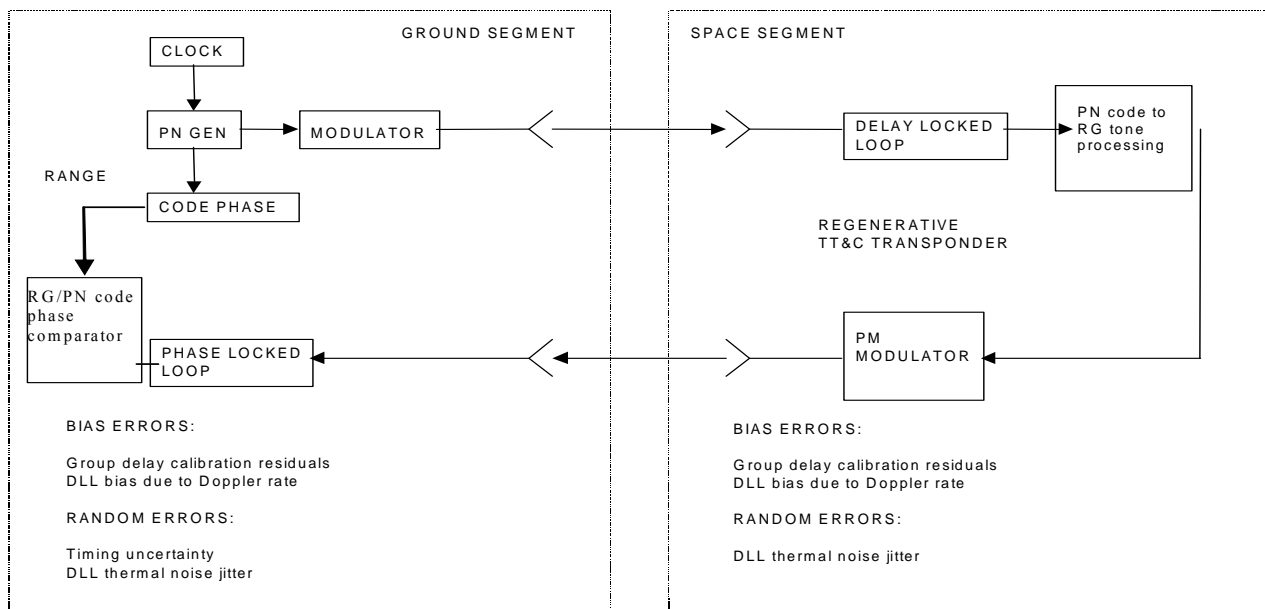

Figure B.1: Hybrid ranging presentation

The timing diagram of the sequence is detailed in figure B.2.

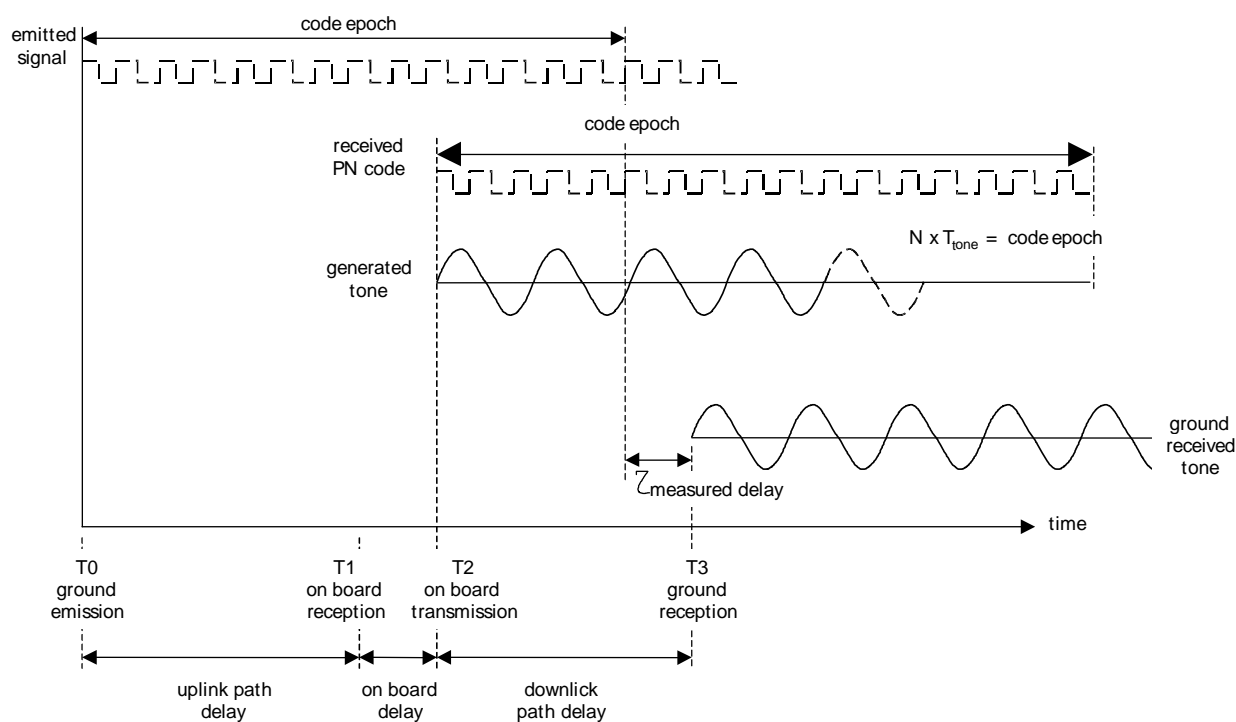

Figure B.2: RG hybrid timing diagram

B.3 Distance ambiguity resolution

The ambiguity of the distance is resolved by using major and minor tones.

The RG measurement is performed:

- with the major tone for the accurate measurement (but the ambiguity will have to be solved);
- with minor tones allowing ambiguity resolution;
- with the minor tones sent sequentially, but simultaneous with the major tone to solve ambiguity;
- virtual minor tones being difficult to send (very low frequency), real tones equal to linear combination of those tones can be sent.

The on board processor will have to send sequentially each minor tone.

EXAMPLE: A change of minor tone occurs at every N PN long code epoch.

At ground level, the RG tones null is compared to the origin of the PN code epoch, and this measured delay is used to determine (with the ambiguity of the major tone) the distance. This measurement is repeated for every minor tone, so that at the end of the measurement, the ambiguity is solved (existing ambiguity resolution algorithm can be used).

Annex C (informative): Modulator imperfections

C.1 Phase imbalance

The modulated signal, at the output of the modulator, is a sum of two signal components called In Phase Channel (I-channel) and Quadrature Phase Channel (Q-channel) respectively. The two signal components have the same carrier with an ideal phase difference of 90°.

The modulated signal has two signal states for BPSK modulation and four signal states for QPSK modulation. Each signal state, N, is characterized by an amplitude, $A_{(N)}$, and a phase, $\Phi_{(N)}$, where $\Phi_{(N)}$ is defined as the difference between the phase of the modulated carrier, when in state N, and the phase of the unmodulated carrier.

C.2 BPSK phase imbalance

For BPSK the ideal phase between the two signal states, with phase $\Phi_{(1)}$, where $\Phi_{(2)}$ respectively, is 180°. The phase imbalance is defined as:

$$\text{BPSK Phase Imbalance (deg)} = 180^\circ - |\Phi_{(1)} - \Phi_{(2)}|$$

where $|\text{argument}|$ denotes the absolute value of the argument.

C.3 QPSK phase imbalance

For QPSK the ideal phase between the four signal states depend on the ideal In Phase to Q channel power ratio. The ideal phase difference, θ_{ideal} , is provided versus In Phase to Q channel (I/Q) power ratio (2 typical values).

Table C.1: Ideal signal state phase differences

I/Q Power Ratio	θ_{ideal}
1:1	90°
1:10	35,1° and 144,9°

Let $\Phi_{(N)}$ denote the phase difference between the actual signal states. The phase (N) imbalance is then defined as:

$$\text{QPSK Phase Imbalance (deg)} = \text{Maximum} (|\Phi_{(N)} - \Phi_{(\text{ideal})}|, N = 1, 2, 3, 4)$$

C.4 Amplitude imbalance

The modulated signal has two signal states for BPSK and four signal states for QPSK modulation. Each signal state, N, is characterized by an amplitude, $A_{(N)}$, and a phase, $\Phi_{(N)}$. The modulated signal from a Phase Shift Keying modulator, being either BPSK, QPSK, UQPSK or OQPSK, is ideally a constant envelope signal or the ratio between the maximum and minimum signal state amplitude is 1:1. Let A_{max} and A_{min} denote the actual amplitudes for the signal state with the maximum amplitude and the signal state with the minimum amplitude as follows:

- $A_{\text{max}} = \text{Maximum}(A_{(N)}, N = 1, 2, 3, 4)$;
- $A_{\text{min}} = \text{Minimum}(A_{(N)}, N = 1, 2, 3, 4)$.

The amplitude imbalance is then defined as:

- Amplitude Imbalance (dB) = $20 \times \log(A_{\max}/A_{\min})$.

C.5 Data asymmetry

The data signal is a continuous sequence of symbols. For NRZ data format, two different symbols exist where one denotes logical zero and the other logical one. The length or duration of the symbol denoting logical zero is ideally equal to the length of the symbol denoting logical one.

The actual length of the symbol denoting logical zero might not be equal to the actual length of symbol denoting logical one. Let L_1 denote the average length of symbols denoting logical one in a data sequence and L_0 denote the average length of symbols denoting logical zero in the data sequence. The data asymmetry is defined as:

$$\text{Data Asymmetry} = | (L_0 - L_1) / (L_0 + L_1) |$$

C.6 Data bit jitter

The data signal is a continuous sequence of symbols. For NRZ data format, two different symbols exist where one denotes logical zero and the other logical one. The length or duration of the symbol denoting logical zero is ideally equal to the length of the symbol denoting logical one.

The actual length of the symbol denoting logical zero might not be equal to the actual length of symbol denoting logical one. Let L_1 denote the average length of symbols denoting logical one in a data sequence and L_0 denote the average length of symbols denoting logical zero in the data sequence. Moreover, let VL_0 denote the variance of the length of symbols denoting logical zero, which is defined as the average of (length of logical zero symbol L_0)², and let VL_1 denote the variance of the length of symbols denoting logical one. The data bit jitter is defined as:

$$\text{Data Bit Jitter} = \frac{\sqrt{VL_1 + VL_0}}{L_1 + L_0}$$

C.7 PN code asymmetry

Defined as for data asymmetry but with chips in place of bits.

C.8 PN code chip jitter

Defined as for data bit jitter but with chips in place of bits.

C.9 Chip transition time

The modulated signal has two signal states for BPSK modulation and four signal states for QPSK modulation. Each signal state, N, is characterized by an amplitude, $A_{(N)}$, and a phase, $\Phi_{(N)}$, where $\Phi_{(N)}$ is the steady state phase angle.

Ideally the phase $\Phi_{(N)}$ changes from the one signal state to the other signal state in an infinitely short time. The actual transition time from the phase $\Phi_{(1)}$, for signal state 1, to change to the subsequent phase $\Phi_{(2)}$, for signal state 2, lasts a finite duration.

Chip Transition Time = the time duration to switch from 90 % of $\Phi_{(1)}$ to 90 % of $\Phi_{(2)}$ divided by the average chip duration.

C.10 I/Q data bit skew

When the data rate modulating the I channel and the data rate modulating the Q channel are the same, there is an ideal relative time delay between the instants of data transitions on the one channel and the instants of data transitions on the other channel. The I/Q data bit skew defines the deviation from this ideal relative time delay. For QPSK the ideal relative time delay is zero whereas for staggered QPSK the relative time delay is 0,5.

Let $t(I_i)$ and $t(Q_i)$ denote the actual data bit transition instants on the I channel and the Q channel respectively.

Moreover, let L_d denote the average length of the data bits and let δ denote the ideal relative time delay. The I/Q data bit skew is defined as:

$$\text{I/Q Data Bit Skew} = \text{Average}((t(I_i) - t(Q_i)) / L_d - \delta)$$

where i denotes the data bit number i in a data sequence and the average is taken over all data bits in the complete data sequence.

C.11 I/Q PN code chip skew

Defined as for data bit skew but with chips in place of bits.

Annex D (informative): SRRC chip filtering

Transfer Function:

The transfer function for the SRRC filter $H(f)$ is detailed below.

$$H(f)/\sqrt{T} = 1 \quad \text{for } 0 \leq |f| \leq (1-\alpha)/2T$$

$$H(f)/\sqrt{T} = \left(0,5 \left(1 + \cos \left(\frac{\pi T}{\alpha} \left(f - \frac{(1-\alpha)}{2T} \right) \right) \right) \right)^{1/2} \quad \text{for } (1-\alpha)/2T \leq |f| \leq (1+\alpha)/2T$$

$$H(f)/\sqrt{T} = 0 \quad \text{for } (1+\alpha)/2T \leq |f|$$

The bandwidth of the SRRC filter is a function of the roll off factor α , which has a value between 0 and 1. The RF bandwidth of the filtered signal is given by:

$$B = (1+\alpha)/T = (1+\alpha)R_c$$

Where R_c is the chip rate of the spreading sequence.

Impulse Response:

The corresponding impulse response for the SRRC filter is detailed below.

$$h(t)\sqrt{T} = \frac{\frac{4\alpha}{T} \cos\left(\frac{(1+\alpha)\pi}{T}\right) + \sin\left(\frac{(1-\alpha)\pi}{T}\right)}{\pi \left(1 - \left(\frac{4\alpha}{T} \right)^2 \right)}$$

For a roll off factor $\alpha = 0,5$ frequency and time domain responses are shown in figures D.1 and D.2 respectively.

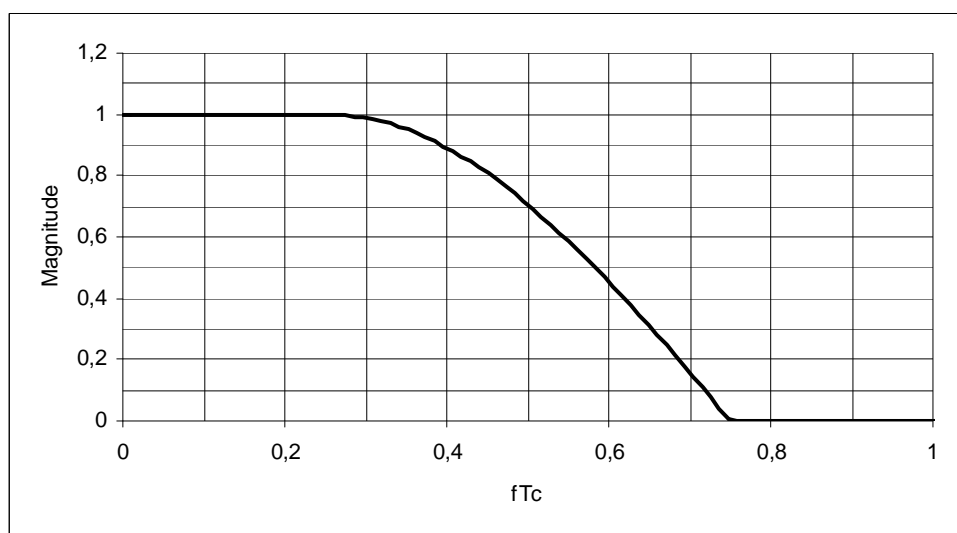

Figure D.1: SRRC frequency response for Alpha = 0,5

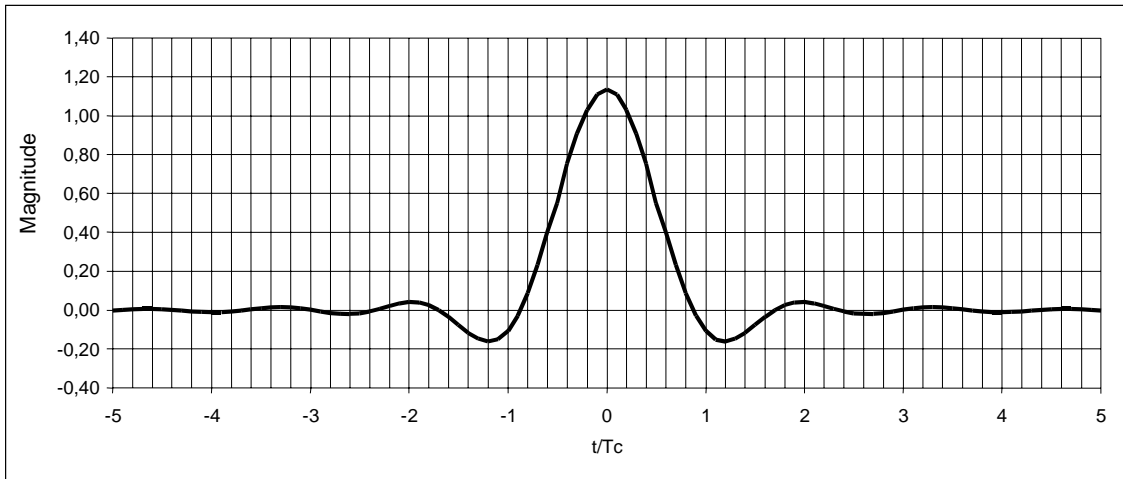

Figure D.2: SRRC impulse response for Alpha = 0,5 (represented over 10 chip periods)

Annex E (normative): PN code assignment, generation and set specification

E.1 PN codes

This annex provides guidance for the specification and selection of PN codes. Clause E.2 provides the minimum requirements for a PN code assignment as well as the general choices. Clause E.3 provides a detailed description of the various PN code generation concepts according to the selected modulation mode for the uplink. Clause E.4 provides the corresponding telemetry downlink PN code generation both in coherent and non-coherent modes. Clause E.5 reproduces the detailed specification of the PN code set as defined on the first issue of the present document and identified on this issue as *Baseline PN Code Set*. Clause E.6 introduces the *Extended PN code library*, which reflects the flexibility added on PN code as part of the standard revision. Some PN code examples are given in clause E.7. It shall be noted that ETSI is the custodian of the PN codes and, therefore, handles corresponding PN code assignments. In this respect a generic *PN Code Request Form* is found in clause E.8.

E.2 PN code assignment

One or more (CDMA system) sets of PN codes shall be assigned per satellite.

A satellite operator can request sets with different modes to accommodate for segregation of TCR and Hosted Payload Management links.

Each set comprises:

- Uplink (Mode MTC2, MTC3 Acquisition) PN code: Telecommand or In-phase channel, Gold code sequence with 511, 1 023, 2 047 or 4 095 chip length.
- Uplink (Mode MTC3 Tracking) PN Code: Telecommand or In-phase channel, truncated Gold code or maximal sequence with 28 possible length values between 32 704 and 16 773 120 chips, based on formula $\text{length} = (2^n - 1) \times 2^m$ with $n \in \{9, 10, 11, 12\}$ and $m \in \{6, 7, 8, 9, 10, 11, 12\}$.
- Uplink (Mode MTC2, MTC3) PN code: Ranging or quadrature channel, truncated Gold code or maximal length sequence with 28 possible length values between 32 704 and 16 773 120 chips.
- Downlink PN code:
 - Coherent Ranging Mode (Mode MTM2): Telemetry and ranging, truncated Gold code or maximal length sequence with 28 possible length values between 32 704 and 16 773 120 chips;
 - Non Coherent Mode (Mode MTM3): Telemetry only, a Gold code sequence of 511, 1 023, 2 047 or 4 095 chips.

Each user satellite shall request an assignment from the competent body responsible, applicable to the present document. The competent body is the European Telecommunications Standards Institute (ETSI), see address in page 2 of the present document.

E.3 PN code generation

E.3.1 PN code generator types

Four different types of code generators shall be considered: single channel (in-phase or quadrature channel) maximal length code generator, dual channel (in-phase and quadrature channel) maximal length code generator, single channel (in-phase or quadrature channel) Gold code generator, and dual channel (in-phase and quadrature channel) Gold code generator. All generators are made up of linear feedback shift registers.

Figure E.1 shows the linear feedback shift register circuit for generating maximum length sequences. The code is determined by the feedback taps. All codewords are shifted versions of each other. They are selected by the initial state of the shift register.

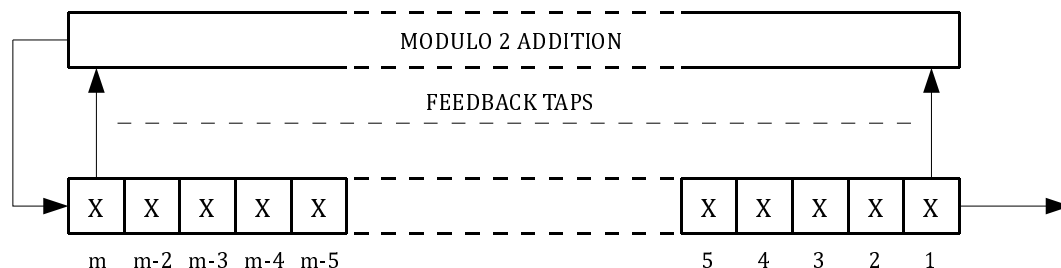

Figure E.1: Linear feedback shift register

Feedback taps and the initial shift register state are given in octal: As an example, figure E.2 shows a 10-stage shift register generator with feedback taps specified as 2011 (octal) which is 10000001001 in binary. The LSB is the feedback connection and shall therefore be equal to 1. The MSB is the feedback tap of register cell 1, which also shall be equal to 1. The initial state is specified as 1110 (octal) which is 1001001000 in binary.

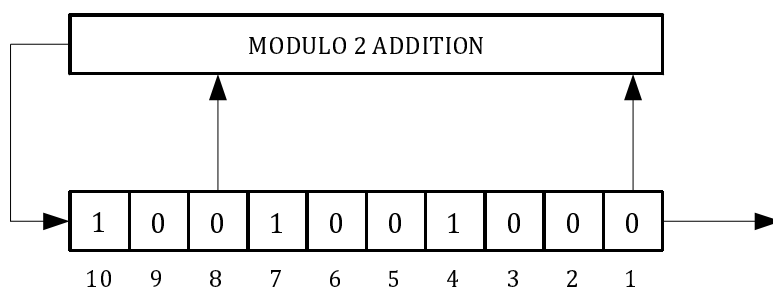

Figure E.2: Example maximal length generator with feedback taps 2011 and initial state 1110

The maximal length code words are specified in table E.1 as shown below. The initial register state is the same for all code words. Usually, the all 1's initialization is chosen. It will be specified outside the table.

Table E.1

Code word	Feedback tap connections
1	
2	

Figure E.3 shows a dual channel maximal length shift register generator. The in-phase channel output is the output of register cell 1. The quadrature-phase channel output is a linear combination (modulo 2) of all register cells. Which register cells are involved is determined by the feed forward taps. They are defined in the same way as the feedback taps.

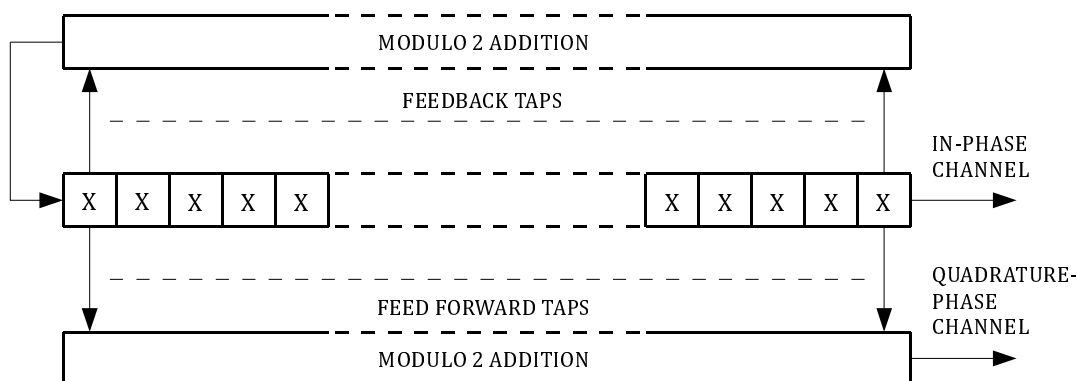

Figure E.3: Dual channel maximal length generator

The dual channel maximal length code words are specified in table E.2 as shown below. The initial register state is the same for all code words. Usually, the all 1's initialization is chosen. The feed forward tap is also the same for all code words. Both will be specified outside the table.

Table E.2

Code word	Feedback tap connections
1	
2	

Figure E.4 shows the single channel Gold code generator. The outputs of two different maximal length code generators are added modulo. The Gold code is determined by the feedback taps of both registers, which shall be different. Different code words are specified via the different initial settings of register A while the initial value of register B is the same for all code words.

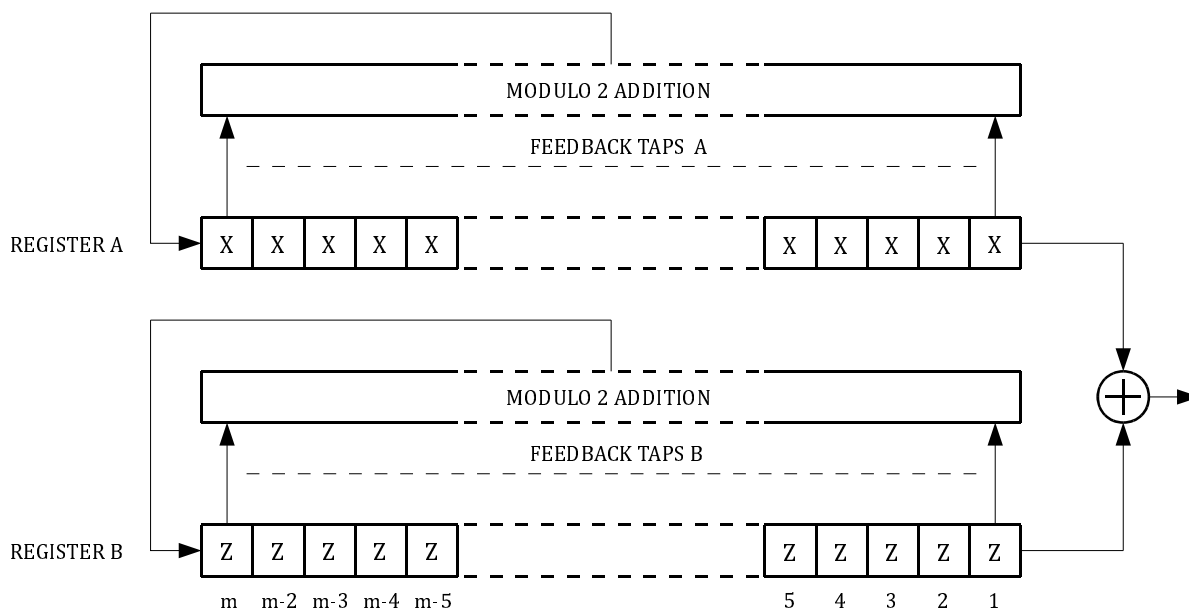

Figure E.4: Single channel Gold code generator

The single channel Gold code words are specified in table E.3 as shown below. The feedback taps and the initial state of register B are the same for all code words. They will be specified outside the table.

Table E.3

Code word	Initial state register A
1	
2	

Figure E.5 shows the dual channel Gold code generator. The in-phase channel code is formed by adding the outputs of register A and register B modulo 2; the quadrature-phase channel code is formed by adding the outputs of register C and register B. The feedback taps A and C are the same such that the code words of both channels are members of the same Gold code. The initial value of register B is fixed. The code words are selected by the initial settings of register A and register C.

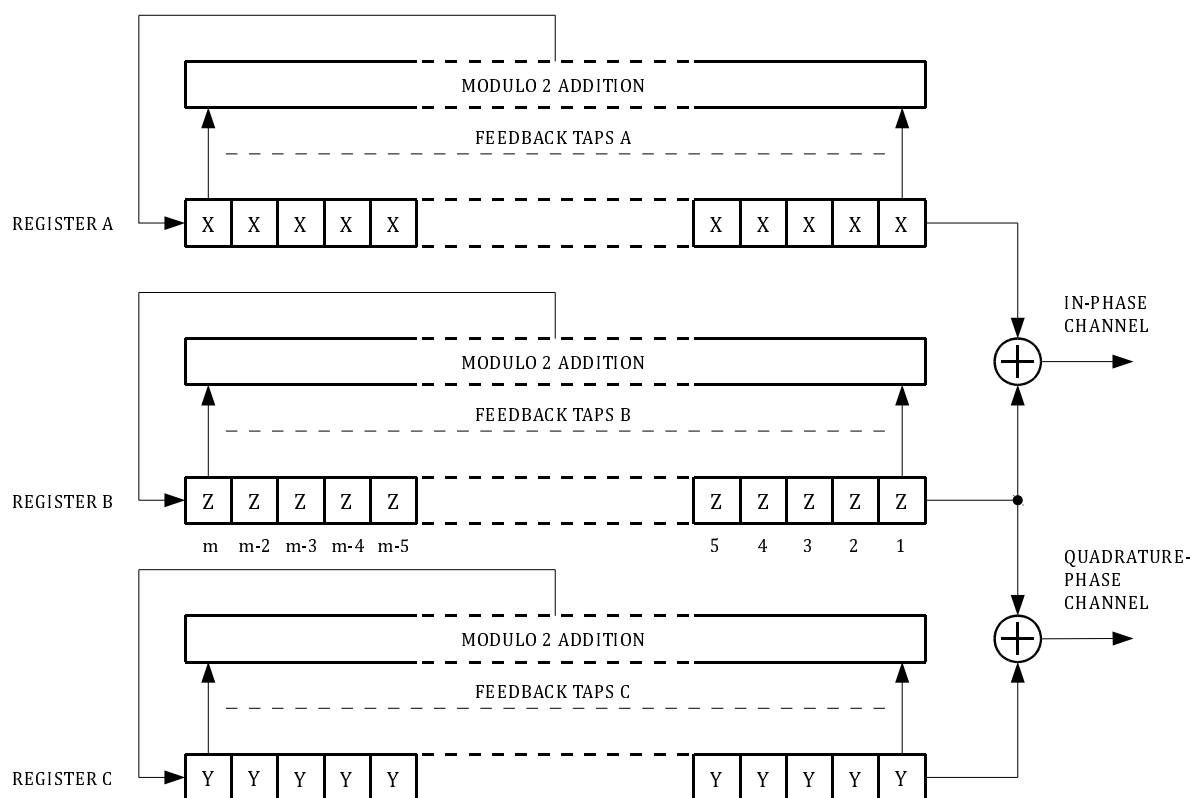

Figure E.5: Dual channel Gold code generator

The dual channel Gold code words are specified in table E.4 as shown below. The feedback taps and the initial state of register B are the same for all code words. They will be specified outside the table.

Table E.4

Code word	Initial state register A	Initial state register C
1		
2		

E.3.1a Telecommand uplink or in-phase channel (Mode MTC2, MTC3 Acquisition)

In mode MTC2 and MTC3 (acquisition phase only), the PN codes for the Telecommand data channel, the In-phase channel, are Gold codes with a length of 511, 1 023, 2 047 and 4 095 chips. These codes are balanced and give good cross-correlation performance, allowing their use for Code Division Multiple Access with the advantage of relatively short acquisition times.

The uplink PN Gold code generator is shown in figure E.4.

E.3.2 Ranging uplink or quadrature channel (Mode MTC2)

In mode MTC2, the PN codes used for the uplink ranging or quadrature channel are Gold sequence or maximal sequence with a code length given by $2^{n+m} - 1$ but truncated to length $(2^n - 1) \times 2^m$ with $n \in \{9, 10, 11, 12\}$ and $m \in \{6, 7, 8, 9, 10, 11, 12\}$. This is done in order to synchronize them to an integral number of the short (Gold) command code epoch lengths. This aids in acquiring the longer ranging code since now only 2^m ranging code positions need be searched following Gold code acquisition.

In case the spread sequences are maximal length sequences, the single channel code generator of figure E.1 shall be used. In case the spread sequences are Gold sequences, the single channel code generator of figure E.4 shall be used.

E.3.3 Telecommand and ranging uplink (Mode MTC3 Tracking)

In mode MTC3 (tracking phase), the PN codes for the Telecommand data channel and ranging are Gold sequence or maximal sequence with a code length given by $2^{n+m} - 1$ but truncated to length $(2^n - 1) \times 2^m$ with $n \in \{9,10,11, 12\}$ and $m \in \{6,7,8,9,10,11, 12\}$. This is done in order to align them to an integral number of the short (Gold) command code epoch lengths and ease transition from MTC3 Acquisition to Tracking modes. The PN code length ranges from a minimum of 32 704 to a maximum of 16 773 120 chips.

Furthermore these PN codes provide a more random MAI, easing acquisition by other CDMA channels in MTC3 acquisition mode.

In case the spread sequences are maximal length sequences, the dual channel code generator of figure E.3 shall be used. In case the spread sequences are Gold sequences, the dual channel code generator of figure E.5 shall be used.

In any case the quadrature-phase code shall also be transmitted during acquisition phase.

E.4 Telemetry Downlink

E.4.1 Coherent ranging mode (Mode MTM2)

In this mode (MTM2) the uplink ranging PN code epoch timing is coherently transferred to the downlink PN code, as is the PN code chip clock. This thus allows two-way ranging with ambiguity resolution.

The PN codes for the telemetry downlink are Gold sequence or maximal sequence with a code length given by $2^{n+m} - 1$ but truncated to length $(2^n - 1) \times 2^m$ with $n \in \{9,10,11, 12\}$ and $m \in \{6,7,8,9,10,11, 12\}$.

In case the spread sequences are maximal length sequences, the dual channel code generator of figure E.3 shall be used. In case the spread sequences are Gold sequences, the dual channel code generator of figure E.5 shall be used.

E.4.2 Non coherent mode (Mode MTM3)

This downlink mode operates if there is no Telecommand and Ranging uplink present at the satellite. The PN codes are dual channel Gold codes with a length of 511, 1 023, 2 047 and 4 095 chips. The appropriate code generator is shown in figure E.5.

E.5 Baseline PN code set specification

Baseline PN codes are a reproduction of the PN codes specified in the first issue of the present document. The PN code for MTC3 is the same as for MTC2 ranging. The values are provided by ETSI on request for a PN code assignment. The numbers in table E.5 are the initial register loading and feedback tap connections in octal presentation.

Table E.5: PN code set assignment (ESA only)

Code set	MTC2 in-phase channel	MTM3		MTC2 quadrature channel	MTM2
		Reg.A	Reg.C		
	Initial register loading			Feedback tap connections	
1	110101101	0514	0752	1124013	1320067
2	110100001	1231	1725	1624021	1105265
3	111011011	2462	3653	1524003	1062127
4	110011001	1144	3526	1550005	1211465
5	110010001	2310	3254	1011505	1036123
6	110110011	0621	2531	1240423	1406551
7	110011011	1443	1262	1006113	1146065
8	110110010	3107	2544	1221411	1023551
9	110011010	2176	3101	1502025	1041467
10	110100101	0375	2203	1014027	1071701

Code set	MTC2 in-phase channel	MTM3		MTC2 quadrature channel	MTM2
		Reg.A	Reg.C		
	Initial register loading			Feedback tap connections	
11	111111010	0772	0407	1110311	1126611
12	110010111	1765	1017	1001651	1442625
13	111000100	3753	2036	1500341	1430351
14	110001000	3726	0075	1200211	1720215
15	110011100	2604	3506	1634001	1423521
16	111000000	1410	3214	1401125	1201617
17	110000000	3021	2431	1402423	1070447
18	111101110	2043	1062	1400043	1003715
19	111011100	1625	1137	1101223	1433601
20	111000111	3453	2276	1242043	1443251
21	110001110	3032	0427	1004447	1470215
22	111101011	2065	1057	1114015	1626023
23	111010110	0153	2136	1111023	1247013
24	110010101	0326	0275	1010051	1244427
25	110011000	0654	0572	1101511	1264415
26	110111111	3161	2511	1214103	1500437
27	111110001	2343	1222	1021611	1203543
28	111100010	0707	2444	1602051	1065505
29	110001001	3076	0441	1104101	1161053
30	110001101	3666	0155	1111045	1620613
31	110101100	2613	1516	1210047	1500731
32	110001111	1335	1663	1056021	1446511
33	110101111	3247	2764	1321011	1331411
34	110011101	2517	1750	1224411	1076405
35	111010111	1703	1042	1406421	1136045
36	110101110	0714	452	1132011	1111331
37	111001001	1776	3001	1442205	1222227
38	111011110	0022	0033	1016141	1125053
39	111100100	0044	0066	1420113	1530215
40	111001000	0550	0734	1220123	1342701
41	111111001	2114	3152	1014251	1311065
42	111110010	0231	2325	1001705	1472013
43	110010011	3604	0106	1306101	1120475
44	110110001	0414	0612	1054121	1217601
45	111010100	2247	1364	1206221	1341611
46	110010010	1536	3361	1604043	1073141
47	111111101	1366	3615	1506003	1534023
48	111110101	0366	0215	1424205	1710215
49	110000010	0754	0432	1232201	1442515
50	111101001	3771	2005	1204151	1544621
51	110100100	3762	0013	1300213	1603251
52	110111100	3440	0260	1550401	1641113
53	111001011	0403	2602	1360401	1056251
54	111011111	0035	2023	1224045	1460417
55	110111110	1676	3141	1402251	1225303
56	111110011	3575	2303	1440425	1122253
57	111100110	3372	0607	1760001	1024157
58	110001011	3250	0774	1212045	1101355
59	110111001	2504	3746	1046025	1502453
60	110010100	1040	3460	1262003	1165025
61	111000001	1204	3706	1120341	1042715
62	111101010	0450	0674	1142061	1071341
63	111111011	1213	1716	1500261	1047641
64	111110110	2426	3635	1013421	1506213
65	111101100	1235	1723	1203105	1443461
66	111011000	2350	3234	1120113	1303243
67	110110000	0721	2471	1210065	1204565
68	110110110	1643	1162	1461011	1054631
69	111100000	2435	1623	1404055	1055261
70	111001111	3513	2356	1464003	1546501

Code set	MTC2 in-phase channel	MTM3		MTC2 quadrature channel	MTM2
		Reg.A	Reg.C		
Initial register loading				Feedback tap connections	
71	110011110	1514	3352	1244045	1532421
72	111000110	2314	3252	1401035	1432541
73	111110100	3147	2524	1604103	1422447
74	110110111	0525	2777	1111051	1061153
75	110111000	3225	2737	1441001	1160721
76	110000011	0603	2502	1401225	1026315
77	111011001	1761	1011	1305401	1206427
78	110010110	0157	2130	1642011	1651045
79	111010001	1647	1164	1502105	1660047
80	110000101	2735	1463	1452003	1146461
81	110100011	1240	3760	1040351	1742405
82	110000111	2500	3740	1021143	1563011
83	111111110	1200	3700	1200057	1730111
84	111111100	2400	3600	1005341	1574005
85	111111000	1000	3400	1404213	1072321
NOTE 1: During acquisition, the MTC3 in-phase code is the same as the MTC2 in-phase code. The MTC3 quadrature-phase code is the quadrature-phase channel from the dual channel shift register generator shown in figure E.3. The feedback taps are the same as for the MTC2 quadrature code. The feed forward taps are specified as 200200 (octal) or 10000000010000000 (binary), i.e. the outputs of register cells 9 and 18 are added modulo 2.					
NOTE 2: During tracking, the MTC3 in-phase code is the in-phase channel from the dual channel shift register generator shown in figure E.3. The feedback taps are the same as for the MTC2 quadrature code.					
NOTE 3: The feed forward taps of the MTM2 quadrature-phase code are specified as 200200 (octal) or 10000000010000000 (binary), i.e. the outputs of register cells 9 and 18 are added modulo 2.					

E.6 Extended PN code library

The extended code library comprises suitable spread codes for all shift-registers lengths from 9 to 24. All codes are defined as dual channel Gold codes. The generic code generator is that of figure E.5. If only a single channel code is required, the in-phase channel output or the quadrature-phase channel output may be used. The feedback taps are specified in table E.2. Initial loadings of registers A and C are defined by ETSI. The initial loading of register B is 00....01 (all zeros except LSB is equal to 1). All initial loadings are chosen in order to generate balanced code words. Further it is guaranteed that all spurious codes which could be generated with I/Q staggered transmission (as is the case for MTM2 and MTM3) are different from all specified codes. The last column of table E.6 reports the number of codes which are in accordance with these two requirements.

Table E.6: Shift register feedback taps of the extended code library dual channel Gold codes

m	Register A (and C)	Register B	Number of Codes
9	1 275	1 225	119
10	2 363	3 575	337
11	7 113	4 745	477
12	13 505	14 357	944
13	33 001	30 733	1 884
14	60 421	74 573	5 376
15	140 001	135 131	7 601
16	320 021	226 135	15 146
17	440 001	605 177	30 223
18	1 004 001	1 643 255	85 542
19	3 440 001	2 470 377	120 788
20	4 400 001	4 563 321	239 579
21	12 000 001	16 776 011	483 840
22	30 000 001	32 454 353	1 384 502
23	63 000 001	40 104 011	1 931 403
24	160 400 001	104 401 661	3 881 062

E.7 Code Examples

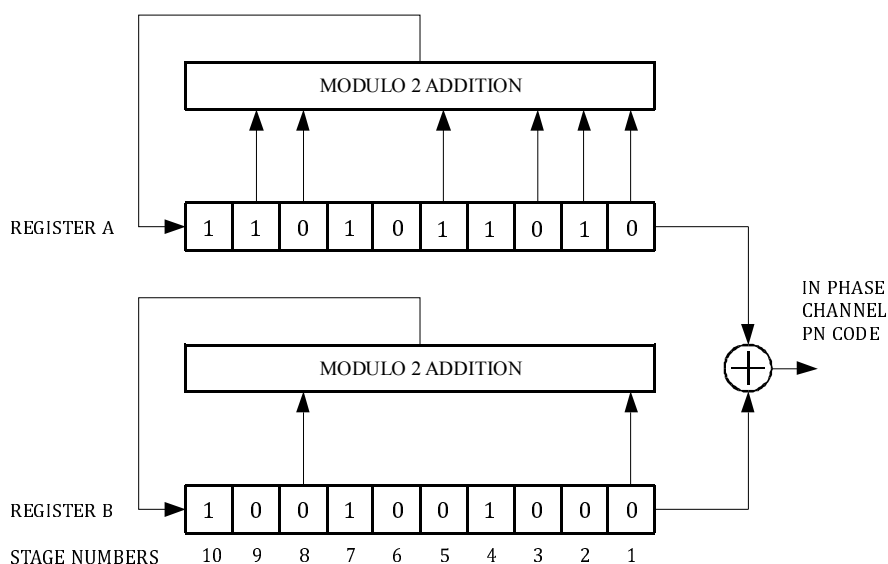

Figure E.6: Example of register loading for gold code based on code set 1, MTC2 in-phase channel (table E.5) - The same is used for MTC3 in-phase channel for acquisition

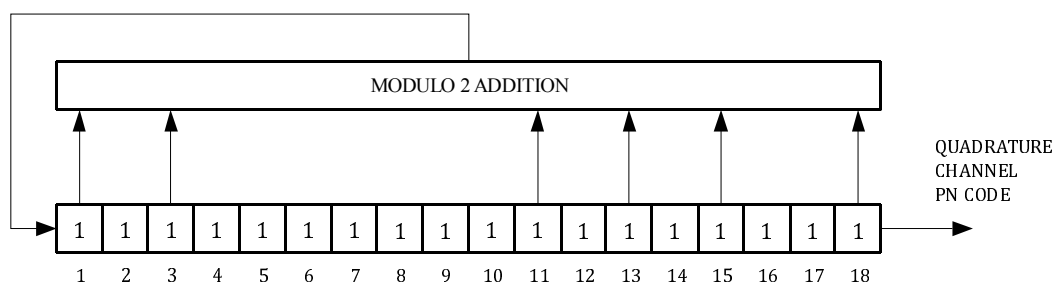

Figure E.7: Example of tap connections for maximum length code based on code set 1, MTC2 quadrature-phase channel (table E.5)

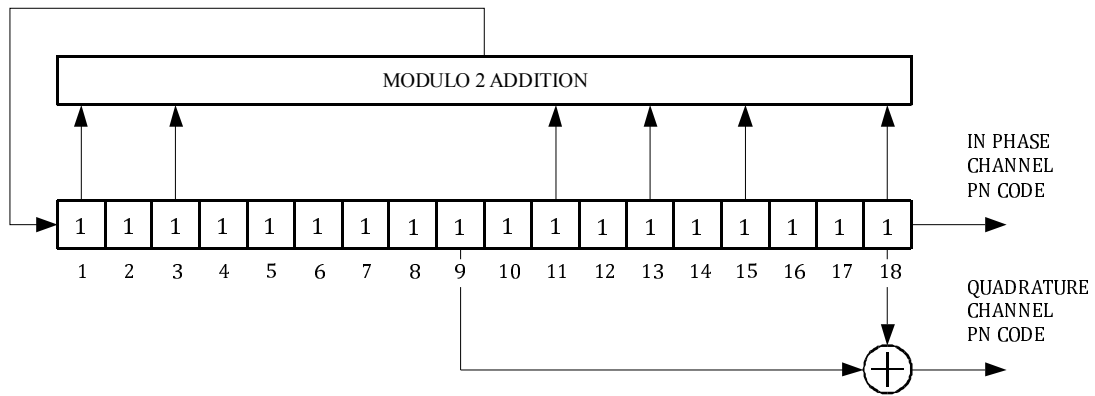

Figure E.8: Example of tap connections for maximum length code based on code set 1, MTC2 (table E.5), used for MTC3-tracking, in-phase and quadrature-phase channel. Quadrature-phase channel is also transmitted for acquisition.

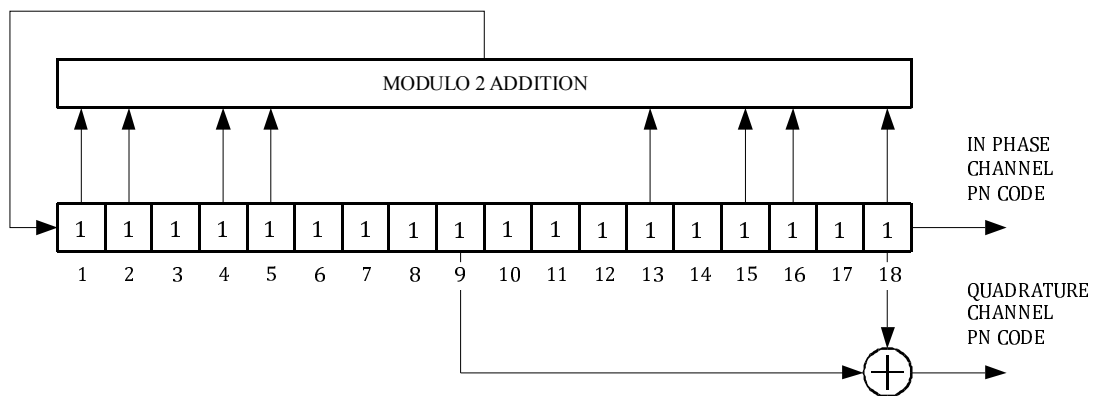

Figure E.9: Example of tap connections for maximum length code based on code set 1, MTM2 (table E.5)

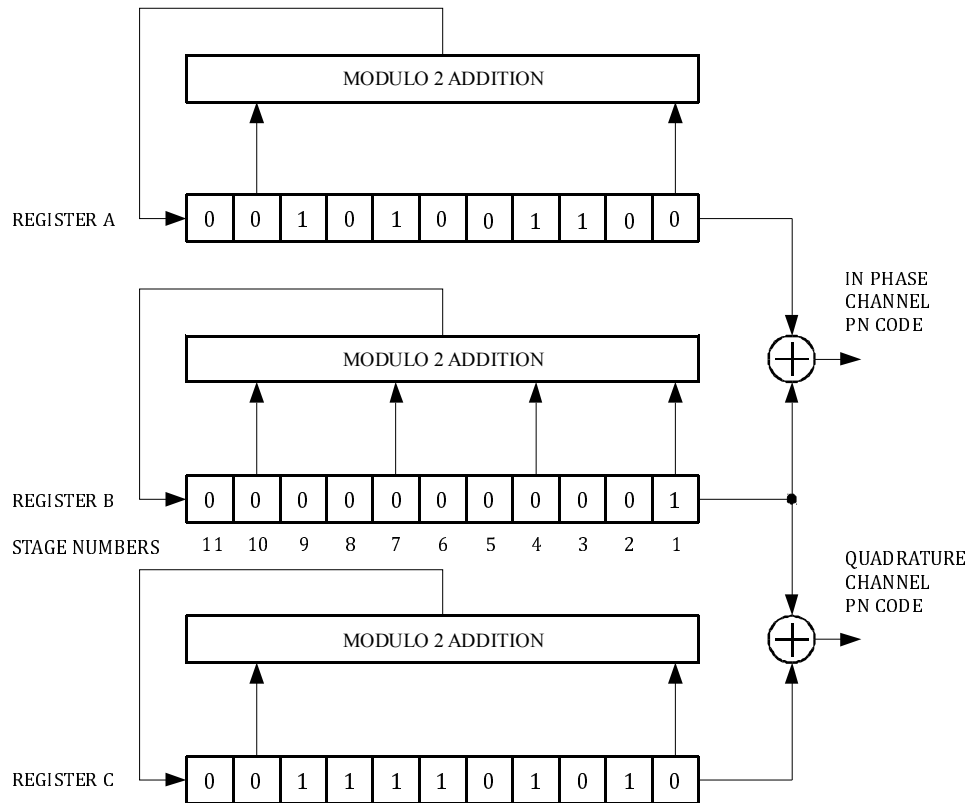

Figure E.10: Example of tap connections for maximum length code based on code set 1, MTM3 (table E.5) - All codes of the extended code library are specified in the same way as the MTM3 codes

E.8 PN CODE REQUEST FORM

E.8.1 Form



PN Code Request Form

Request Information	
Request date	
Request number (to be filled by ETSI)	
Personal and Billing Information	
Organization	
ETSI Membership	
Contact person	
E-mail	
Department	
Phone	
Fax	
Business address	
Satellite Information	
Designation (space station)	
Launch date	
Estimated EOL Date	
Orbit (GSO/non-GSO)	
Orbital parameters	
Satellite Operator (Y/N)	
Hosted Payload Operator (Y/N)	
PN Code Information	
Link (Up/Down)	
Function (TCR/HPM)	
Frequency (fixed/flexible)	
PN Code Parameters	n
	m
	Length order
Requested number of PN Codes	

E.8.2 Description and Instructions

This form provides an identification of the relevant elements of information required by ETSI to provide identified and validated users with PN codes.

It is anticipated that ETSI will provide users with a web-based portal where users will be able to fill in such a form on line. Instructions for their completion are given hereafter.

Personal and Billing Information

The fields are self-explanatory. It is essential that the organization requesting the codes identifies a contact person and their ETSI Membership status.

Satellite Information

This part of the form shall contain information to identify the satellite or satellites for which the PN codes are requested. It is recommended to use the same terminology employed as for frequency filing in the International Telecommunication Union (ITU).

The distinction between GSO and non-GSO orbits will allow ETSI to consider PN code reuse possibility. Non-GSO codes are not expected to be reused. GSO codes may be reused depending on their application (see next section of the form).

PN Code Information

PN codes can be requested for uplink or downlink. The distinction is important since downlinks have terrestrial coverage, driven by the satellite antenna gain, whereas uplinks have orbital coverage typically limited by directive antennas on ground stations. Hence, different considerations apply for their potential reuse.

ETSI needs to understand as well if the codes are planned to be used for satellite operations (TCR) or for Hosted Payload Management (HPM). This distinction is important in particular for GSO satellites. Codes for hosted payload management can be reused on different orbital slots whereas codes for satellite operations cannot.

Frequency offers another degree of flexibility for code administration. Codes can be allocated to a single frequency or a frequency band specified with upper and lower frequency values.

PN code parameters 'n' and 'm' introduced in clause E.2. The user shall judiciously select the values for 'n' and 'm' considering in particular the number of expected simultaneous links sharing the requested frequency or band. The 'length order' is simply the addition 'n+m'.

Finally, the user shall specify the number of PN Codes required in the last field of this form.

Annex F (informative): Performance computations

For performance computations, refer to ETSI TR 101 956 [i.1].

Annex G (informative): Bandwidth considerations and assumptions

In order to guarantee sufficient protection between TCR and COM channels, the following has been assumed for the background analysis to the present document for SS modes (see [i.1]):

- COM channel suppression in TC and TM bands has been assumed for the analysis to be ≤ 25 dBc in relation to the COM channel PSD.
- TC and TM suppression in COM bands should be ≤ 25 dBc in relation to the TC and TM PSD respectively. This is achieved by the selected Spread Spectrum Modulations:
 - Uplink Mode MTC2: SRRC-UQPSK modulation through linear Groundstation HPA gives TC Bandwidth of $1,5 \times R_c$ (1,5 MHz or 4,5 MHz, where R_c = chip rate).
 - Downlink Mode MTM2: SRRC-OQPSK modulation (almost constant amplitude envelope) through (possibly saturated) Spacecraft HPA gives TM Bandwidth of $1,5 \times R_c$ (1,5 MHz or 4,5 MHz, where R_c = chip rate).

History

Document history		
V1.2.1	June 2002	Publication
V1.3.0	June 2017	EN Approval Procedure AP 20170920: 2017-06-22 to 2017-09-20