

ETSI EN 301 925 V1.6.1 (2020-12)



EUROPEAN STANDARD

**Radiotelephone transmitters and receivers for
the maritime mobile service operating in VHF bands;
Technical characteristics and methods of measurement**

Reference

REN/ERM-TGMAR-607

Keywords

EMC, GMDSS, maritime, radio, telephony, VHF

ETSI

650 Route des Lucioles
F-06921 Sophia Antipolis Cedex - FRANCE

Tel.: +33 4 92 94 42 00 Fax: +33 4 93 65 47 16

Siret N° 348 623 562 00017 - NAF 742 C
Association à but non lucratif enregistrée à la
Sous-Préfecture de Grasse (06) N° 7803/88

Important notice

The present document can be downloaded from:

<http://www.etsi.org/standards-search>

The present document may be made available in electronic versions and/or in print. The content of any electronic and/or print versions of the present document shall not be modified without the prior written authorization of ETSI. In case of any existing or perceived difference in contents between such versions and/or in print, the prevailing version of an ETSI deliverable is the one made publicly available in PDF format at www.etsi.org/deliver.

Users of the present document should be aware that the document may be subject to revision or change of status.

Information on the current status of this and other ETSI documents is available at

<https://portal.etsi.org/TB/ETSIDeliverableStatus.aspx>

If you find errors in the present document, please send your comment to one of the following services:

<https://portal.etsi.org/People/CommiteeSupportStaff.aspx>

Copyright Notification

No part may be reproduced or utilized in any form or by any means, electronic or mechanical, including photocopying and microfilm except as authorized by written permission of ETSI.

The content of the PDF version shall not be modified without the written authorization of ETSI.

The copyright and the foregoing restriction extend to reproduction in all media.

© ETSI 2020.

All rights reserved.

DECT™, **PLUGTESTS™**, **UMTS™** and the ETSI logo are trademarks of ETSI registered for the benefit of its Members.

3GPP™ and **LTE™** are trademarks of ETSI registered for the benefit of its Members and of the 3GPP Organizational Partners.

oneM2M™ logo is a trademark of ETSI registered for the benefit of its Members and of the oneM2M Partners.

GSM® and the GSM logo are trademarks registered and owned by the GSM Association.

Contents

Intellectual Property Rights	8
Foreword.....	8
Modal verbs terminology.....	8
1 Scope	9
2 References	9
2.1 Normative references	9
2.2 Informative references.....	10
3 Definition of terms, symbols and abbreviations.....	11
3.1 Terms.....	11
3.2 Symbols.....	12
3.3 Abbreviations	12
4 General requirements	13
4.1 Construction	13
4.2 DSC operation.....	13
4.3 Controls and indicators.....	14
4.4 Handset and loudspeaker.....	14
4.5 Safety precautions	15
4.6 Labelling.....	15
4.7 Warm up.....	15
4.8 Audio Processing.....	15
5 Technical requirements	16
5.1 Switching time.....	16
5.2 Class of emission and modulation characteristics	16
5.3 Multiple watch facilities	16
5.3.1 Additional performance standards	16
5.3.2 Scanning characteristics.....	17
5.4 Interfaces	17
5.4.1 General.....	17
5.4.2 Audio frequency	17
5.4.3 Digital interfaces.....	17
5.5 Voyage data recorder interface.....	18
6 Test conditions, power sources and ambient temperatures	18
6.1 Test conditions	18
6.2 Test power source.....	18
6.3 Normal test conditions.....	18
6.3.1 Normal temperature and humidity	18
6.3.2 Normal power source voltage	18
6.3.2.1 Mains powered equipment	18
6.3.2.2 Battery powered equipment	19
6.3.2.3 Other power sources.....	19
6.4 Extreme test conditions	19
6.4.1 Extreme temperatures	19
6.4.2 Extreme values of power source voltage	19
6.4.2.1 Mains powered equipment	19
6.4.2.2 Battery powered equipment	19
6.4.2.3 Other power sources.....	19
6.5 Procedure for tests at extreme temperatures.....	19
7 General conditions of measurement	19
7.1 Sequence of testing.....	19
7.2 Test channels	20
7.3 Squelch.....	20
7.4 Arrangements for test signals applied to the receiver input.....	20

7.5	Normal test modulation of the receiver wanted signal	20
7.6	Arrangements for monitoring the receiver output	20
7.7	Arrangements for test signals applied to the transmitter input	21
7.8	Normal test modulation of the transmitter.....	21
7.9	Arrangements for monitoring the transmitter output.....	21
7.10	Arrangements for test of DSC	21
7.11	Standard test signals for DSC.....	21
7.12	Determination of symbol error ratio in the output of the receiver.....	21
7.13	Reference bandwidths for spurious measurements.....	22
7.14	Interpretation of the measurement results	22
8	Performance checks.....	23
8.1	Performance checks - introduction.....	23
8.2	Performance check - transmitter frequency error	23
8.3	Performance check - transmitter carrier power	23
8.4	Performance check - transmitter audio frequency harmonic distortion.....	23
8.5	Performance check - receiver sensitivity	23
8.6	Performance check of DSC	23
9	Environmental tests	24
9.1	Procedure.....	24
9.2	Vibration test.....	24
9.2.1	Definition.....	24
9.2.2	Method of measurement	24
9.2.3	Requirement.....	25
9.3	Temperature tests	25
9.3.1	Introduction.....	25
9.3.2	General procedure.....	25
9.3.3	Dry heat	25
9.3.3.1	Definition	25
9.3.3.2	Method of measurement.....	25
9.3.3.3	Requirement	25
9.3.4	Damp heat.....	25
9.3.4.1	Definition	25
9.3.4.2	Method of measurement.....	25
9.3.4.3	Requirement	26
9.3.5	Low temperature cycle.....	26
9.3.5.1	Definition	26
9.3.5.2	Method of measurement.....	26
9.3.5.3	Requirement	26
10	Transmitter	26
10.1	General conditions.....	26
10.2	Frequency error	26
10.2.1	Definition.....	26
10.2.2	Method of measurement	26
10.2.3	Limits.....	27
10.3	Carrier power.....	27
10.3.1	Definitions	27
10.3.2	Method of measurement	27
10.3.3	Limits.....	27
10.3.3.1	General	27
10.3.3.2	Normal test conditions limits	27
10.3.3.3	Extreme test conditions limits	27
10.4	Frequency deviation	27
10.4.1	Definition.....	27
10.4.2	Maximum permissible frequency deviation.....	28
10.4.2.1	Method of measurement.....	28
10.4.2.2	Limits.....	28
10.4.3	Reduction of frequency deviation at modulation frequencies above 3 kHz.....	28
10.4.3.1	Method of measurement.....	28
10.4.3.2	Limits	28
10.5	Sensitivity of the modulator including the microphone	29

10.5.1	Definition.....	29
10.5.2	Method of measurement	29
10.5.3	Limits.....	29
10.6	Audio frequency response	29
10.6.1	Definition.....	29
10.6.2	Method of measurement	30
10.6.3	Limits.....	30
10.7	Audio frequency harmonic distortion of the emission.....	30
10.7.1	Definition.....	30
10.7.2	Method of measurement	31
10.7.3	Limits.....	31
10.8	Adjacent channel power	31
10.8.1	Definition.....	31
10.8.2	Method of measurement	31
10.8.3	Limits.....	32
10.9	Conducted spurious emissions conveyed to the antenna	32
10.9.1	Definition.....	32
10.9.2	Method of measurement	32
10.9.3	Limit	32
10.10	Residual modulation of the transmitter	32
10.10.1	Definition.....	32
10.10.2	Method of measurement	32
10.10.3	Limit	33
10.11	Transient frequency behaviour of the transmitter.....	33
10.11.1	Definition.....	33
10.11.2	Method of measurement	33
10.11.3	Limits.....	34
10.12	Radiated spurious emission	36
10.12.1	Definition.....	36
10.12.2	Method of measurement	36
10.12.3	Limits.....	37
11	Transmitter with DSC encoder.....	37
11.1	General	37
11.2	Frequency error (carrier)	37
11.2.1	Definition.....	37
11.2.2	Method of measurement	37
11.2.3	Limits.....	38
11.3	Frequency error (demodulated signal).....	38
11.3.1	Definition.....	38
11.3.2	Method of measurement	38
11.3.3	Limits.....	38
11.4	Carrier Power	38
11.4.1	Definition.....	38
11.4.2	Method of measurement	38
11.4.3	Limits.....	38
11.4.3.1	Normal test conditions	38
11.4.3.2	Extreme test conditions	39
11.5	Modulation index	39
11.5.1	Definition.....	39
11.5.2	Method of measurement	39
11.5.3	Limits.....	39
11.6	Modulation rate	39
11.6.1	Definition.....	39
11.6.2	Method of measurement	39
11.6.3	Limits.....	39
11.7	Residual modulation.....	39
11.7.1	Definition.....	39
11.7.2	Method of measurement	39
11.7.3	Limits.....	40
11.8	Modulator attack time	40
11.8.1	Definition.....	40

11.8.2	Method of measurement	40
11.8.3	Limit	40
11.9	Adjacent channel power	40
11.9.1	Definition.....	40
11.9.2	Method of measurement	40
11.9.3	Limits.....	41
11.10	Conducted spurious emissions	41
11.11	Testing of free channel transmission on DSC channel 70	41
11.11.1	Definition.....	41
11.11.2	Method of measurement	41
11.11.3	Requirement.....	41
11.12	Generated DSC call sequences.....	42
12	Receiver.....	42
12.1	Harmonic distortion and rated audio output power	42
12.1.1	Definition.....	42
12.1.2	Methods of measurement	42
12.1.3	Limits.....	42
12.2	Audio frequency response	42
12.2.1	Definition.....	42
12.2.2	Method of measurement	43
12.2.3	Limits.....	43
12.3	Maximum usable sensitivity.....	44
12.3.1	Definition.....	44
12.3.2	Method of measurement	44
12.3.3	Limits.....	44
12.4	Amplitude characteristic of the receiver.....	44
12.4.1	Definition.....	44
12.4.2	Method of measurement	44
12.4.3	Limits.....	44
12.5	Co-channel rejection.....	45
12.5.1	Definition.....	45
12.5.2	Method of measurement	45
12.5.3	Limit	45
12.6	Adjacent channel selectivity.....	45
12.6.1	Definition.....	45
12.6.2	Method of measurement	45
12.6.3	Limits.....	46
12.7	Spurious response rejection.....	46
12.7.1	Definition.....	46
12.7.2	Method of measurement	46
12.7.2.1	Introduction to the method of measurement.....	46
12.7.2.2	Method of search over the "limited frequency range".....	47
12.7.2.3	Method of measurement.....	47
12.7.3	Limit	47
12.8	Intermodulation response	47
12.8.1	Definition.....	47
12.8.2	Method of measurement	48
12.8.3	Limit	48
12.9	Blocking or desensitization	48
12.9.1	Definition.....	48
12.9.2	Method of measurement	48
12.9.3	Limit	48
12.10	Conducted spurious emissions	49
12.10.1	Definition.....	49
12.10.2	Method of measurement	49
12.10.3	Limit	49
12.11	Receiver noise and hum level.....	49
12.11.1	Definition.....	49
12.11.2	Method of measurement	49
12.11.3	Limit	49
12.12	Squelch operation.....	50

12.12.1	Description.....	50
12.12.2	Squelch audio muting	50
12.12.2.1	Definition	50
12.12.2.2	Method of measurement.....	50
12.12.2.3	Limits	50
12.12.3	Squelch operating level.....	50
12.12.3.1	Definition	50
12.12.3.2	Method of measurement.....	50
12.12.3.3	Limits	50
12.12.4	Squelch hysteresis.....	51
12.12.4.1	Definition	51
12.12.4.2	Method of measurement.....	51
12.12.4.3	Limit.....	51
12.13	Multiple watch characteristics	51
12.13.1	Definitions	51
12.13.2	Method of measurement	51
12.13.3	Limits.....	52
12.14	Radiated spurious emissions.....	52
12.14.1	Definition.....	52
12.14.2	Method of measurement	52
12.14.3	Limits.....	53
13	Receiver with a DSC decoder	53
14	Duplex operation	53
14.1	Introduction	53
14.2	Receiver desensitization with simultaneous transmission and reception.....	54
14.2.1	Definition.....	54
14.2.2	Method of measurement	54
14.2.3	Limits.....	54
14.3	Duplex transceiver internal mixing	54
14.3.1	Definition.....	54
14.3.2	Method of measurement	54
14.3.3	Limits.....	55
Annex A (normative): Measuring receiver for adjacent channel power measurement.....		56
A.1	General description of power measuring receiver.....	56
A.2	IF filter.....	56
A.3	Attenuation indicator.....	57
A.4	RMS value indicator.....	57
A.5	Oscillator and amplifier.....	57
Annex B (normative): Protocol for the IEC 61162-1 commands Frequency Set Information (FSI)		58
B.1	Frequency Set Information (FSI)	58
Annex C (informative): DSC test calls.....		59
C.1	Interoperability tests.....	59
History		60

Intellectual Property Rights

Essential patents

IPRs essential or potentially essential to normative deliverables may have been declared to ETSI. The information pertaining to these essential IPRs, if any, is publicly available for **ETSI members and non-members**, and can be found in ETSI SR 000 314: *"Intellectual Property Rights (IPRs); Essential, or potentially Essential, IPRs notified to ETSI in respect of ETSI standards"*, which is available from the ETSI Secretariat. Latest updates are available on the ETSI Web server (<https://ipr.etsi.org/>).

Pursuant to the ETSI IPR Policy, no investigation, including IPR searches, has been carried out by ETSI. No guarantee can be given as to the existence of other IPRs not referenced in ETSI SR 000 314 (or the updates on the ETSI Web server) which are, or may be, or may become, essential to the present document.

Trademarks

The present document may include trademarks and/or tradenames which are asserted and/or registered by their owners. ETSI claims no ownership of these except for any which are indicated as being the property of ETSI, and conveys no right to use or reproduce any trademark and/or tradename. Mention of those trademarks in the present document does not constitute an endorsement by ETSI of products, services or organizations associated with those trademarks.

Foreword

This European Standard (EN) has been produced by ETSI Technical Committee Electromagnetic compatibility and Radio spectrum Matters (ERM).

National transposition dates	
Date of adoption of this EN:	8 December 2020
Date of latest announcement of this EN (doa):	31 March 2021
Date of latest publication of new National Standard or endorsement of this EN (dop/e):	30 September 2021
Date of withdrawal of any conflicting National Standard (dow):	30 September 2021

Modal verbs terminology

In the present document **"shall"**, **"shall not"**, **"should"**, **"should not"**, **"may"**, **"need not"**, **"will"**, **"will not"**, **"can"** and **"cannot"** are to be interpreted as described in clause 3.2 of the [ETSI Drafting Rules](#) (Verbal forms for the expression of provisions).

"must" and **"must not"** are **NOT** allowed in ETSI deliverables except when used in direct citation.

1 Scope

The present document specifies the minimum requirements for shipborne radio transmitters and receivers for fixed installations operating in the VHF frequency bands between 156 MHz and 174 MHz used by the maritime mobile service, using both 25 kHz and 12,5 kHz channels and capable of Radiotelephony and Digital Selective Calling communications within the Global Maritime Distress and Safety System. The present document incorporates the requirements of the relevant resolutions of the International Maritime Organization (IMO) and is primarily intended to specify equipment suitable for fitting to ships subject to the SOLAS Convention [i.2] and complying with the Council Directive 2014/90/EU [i.3] of 23 July 2014 on marine equipment (the European Marine Equipment Directive).

The present document does not address the testing of ancillary equipment on a stand-alone basis, i.e. separately from the radio equipment with which it is to be used.

2 References

2.1 Normative references

References are either specific (identified by date of publication and/or edition number or version number) or non-specific. For specific references, only the cited version applies. For non-specific references, the latest version of the referenced document (including any amendments) applies.

Referenced documents which are not found to be publicly available in the expected location might be found at <https://docbox.etsi.org/Reference/>.

NOTE: While any hyperlinks included in this clause were valid at the time of publication, ETSI cannot guarantee their long term validity.

The following referenced documents are necessary for the application of the present document.

- [1] IMO Resolution A.694(17): "General Requirements for Shipborne Radio Equipment Forming Part of the Global Maritime Distress and Safety System (GMDSS) and for Electronic Navigational Aids".
- [2] Void.
- [3] IMO Resolution A.803(19) (as amended by MSC.68(68)): "Performance Standards for Shipborne VHF Radio Installations capable of Voice Communications and Digital Selective Calling".
- [4] ITU Radio Regulations (2020).
- [5] Recommendation ITU-R M.493-15 (2019): "Digital selective-calling system for use in the maritime mobile service".
- [6] Recommendation ITU-R M.541-10 (2015): "Operational procedures for the use of digital selective-calling equipment in the maritime mobile service".
- [7] Recommendation ITU-T O.41 (1994): "Psophometer for use on telephone-type circuits".
- [8] Void.
- [9] ETSI EN 300 338-2 (V1.5.1): "Technical characteristics and methods of measurement for equipment for generation, transmission and reception of Digital Selective Calling (DSC) in the maritime MF, MF/HF and/or VHF mobile service; Part 2: Class A DSC".
- [10] IEC 61162-1 (2016): "Maritime navigation and radiocommunication equipment and systems - Digital interfaces - Part 1: Single talker and multiple listeners".
- [11] Void.
- [12] ETSI TS 103 052 (V1.1.1) (03-2011): "Electromagnetic compatibility and Radio spectrum Matters (ERM); Radiated measurement methods and general arrangements for test sites up to 100 GHz".

- [13] Void.
- [14] Recommendation ITU-R M.1084-5 (2012): "Interim solutions for improved efficiency in the use of the band 156-174 MHz by stations in the maritime mobile service".
- [15] Void.
- [16] IEC 61000-4-11 (Ed.3.0) (2020): "Electromagnetic compatibility (EMC) - Part 4-11: Testing and measurement techniques - Voltage dips, short interruptions and voltage variations immunity tests for equipment with input current up to 16 A per phase".
- [17] ETSI EN 301 033 (V1.4.1) (2013): "Electromagnetic compatibility and Radio spectrum Matters (ERM); Technical characteristics and methods of measurement for shipborne watchkeeping receivers for reception of Digital Selective Calling (DSC) in the maritime MF, MF/HF and VHF bands".
- [18] Recommendation ITU-R M.489-2 (1995): "Technical characteristics of VHF radiotelephone equipment operating in the maritime mobile service in channels spaced by 25 kHz".
- [19] Recommendation ITU-R SM.329-12 (2012): "Unwanted emissions in the spurious domain".
- [20] Void.
- [21] Recommendation ITU-T E.161 (2001): "Arrangement of digits, letters and symbols on telephones and other devices that can be used for gaining access to a telephone network".

2.2 Informative references

References are either specific (identified by date of publication and/or edition number or version number) or non-specific. For specific references, only the cited version applies. For non-specific references, the latest version of the referenced document (including any amendments) applies.

NOTE: While any hyperlinks included in this clause were valid at the time of publication, ETSI cannot guarantee their long term validity.

The following referenced documents are not necessary for the application of the present document but they assist the user with regard to a particular subject area.

- [i.1] IMO Resolution A.524(13): "Performance Standards for VHF Multiple Watch Facilities".
- [i.2] IMO SOLAS 1974: "International Convention for the Safety of Life at Sea" as amended.
- [i.3] Council Directive 2014/90/EU of 23 July 2014 on marine equipment.
- [i.4] ETSI TR 100 028-1 (V1.4.1) (12-2001): "Electromagnetic compatibility and Radio spectrum Matters (ERM); Uncertainties in the measurement of mobile radio equipment characteristics; Part 1".
- [i.5] ETSI TS 101 570-2 (V1.2.1): "Interoperability Testing for Maritime Digital Selective Calling (DSC) Radios; Part 2: Class A/B Test Descriptions".
- [i.6] EN 60945 (2002): "Maritime navigation and radiocommunication equipment and systems - General requirements - Methods of testing and required test results", produced by CENELEC.
- [i.7] ETSI TR 100 028-2 (V1.4.1) (12-2001): "Electromagnetic compatibility and Radio spectrum Matters (ERM); Uncertainties in the measurement of mobile radio equipment characteristics; Part 2".
- [i.8] ETSI EN 301 843-2: "ElectroMagnetic Compatibility (EMC) standard for marine radio equipment and services; Harmonised Standard for electromagnetic compatibility; Part 2: Specific conditions for VHF radiotelephone transmitters and receivers".
- [i.9] Recommendation ITU-R SM.332-4 (1978): "Selectivity of receivers".

[i.10] Recommendation ITU-R M.689-2 (1994): "International maritime VHF radiotelephone system with automatic facilities based on DSC signalling format".

3 Definition of terms, symbols and abbreviations

3.1 Terms

For the purposes of the present document, the following terms apply:

ancillary equipment: equipment (apparatus) used in connection with a transmitter or receiver is considered to be an ancillary equipment if:

- the equipment is intended for use in conjunction with a transmitter or receiver to provide additional operational or control features to the radio equipment (e.g. to extend control to another position or location); and
- the equipment cannot be used on a standalone basis to provide user functions independently of the radio equipment; and
- the radio equipment to which it is connected is capable of providing some intended operation, such as transmitting or receiving, without the ancillary equipment (i.e. it is not a sub-unit of the radio equipment essential to the basic functions of the radio equipment).

duplex operation: operating method in which transmission is possible simultaneously in both directions of a telecommunications channel

enclosure port: physical boundary of the apparatus through which electromagnetic fields may radiate or impinge

NOTE: In the case of integral antenna equipment, this port is inseparable from the antenna port.

equipment: marine receiver, transmitter or transmitter/receiver (transceiver) intended for installation and use onboard ships, and powered by the ship's supply

NOTE: Such equipment may be operated with ancillary equipment but, if so, is not dependent upon it for basic functionality.

G2B: phase-modulation (frequency modulation with a pre-emphasis of 6 dB/octave) for Digital Selective Calling (DSC) operation

NOTE: The carrier is modulated by a sub-carrier which is FSK modulated by digital data.

G3E: phase-modulation (frequency modulation with a pre-emphasis of 6 dB/octave) for speech operation

integral antenna: antenna designed to be connected directly to the equipment with or without the use of an external connector and considered to be part of the equipment

NOTE: An integral antenna may be fitted internally or externally to the equipment.

modulation index: ratio between the frequency deviation and the frequency of the modulating audio signal

performance check: check of the transmitter frequency error, carrier power, audio frequency harmonic distortion of emission; and receiver sensitivity

port: particular interface of the specified equipment (apparatus), with the electromagnetic environment

EXAMPLE: Any connection point on an equipment intended for connection of cables to or from that equipment is considered as a port (see Figure 1).

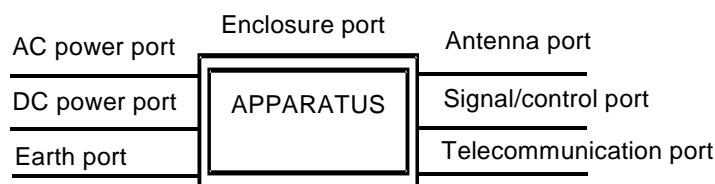

Figure 1: EUT Ports for EMC purposes

Q ratio: ratio of an observed magnitude of acceleration at the equipment to the magnitude of acceleration at the base of the vibration table

semi-duplex operation: operating method in which simplex operation is used at one end of the circuit and duplex operation at the other

simplex: operating method in which transmission is made possible alternately in each direction of a telecommunications channel, for example, by means of manual control

spurious emission: emission on a frequency, or frequencies, which are outside the necessary bandwidth and the level of which may be reduced without affecting the corresponding transmission of information

NOTE: Spurious emissions include harmonic emissions, parasitic emissions, intermodulation products and frequency conversion products but exclude out-of-band emissions (see ITU Radio Regulations [4]).

switching range: maximum frequency range over which the receiver or the transmitter can be operated without reprogramming or realignment

3.2 Symbols

For the purposes of the present document, the following symbols apply:

dBa	sound pressure relative to 2×10^{-5} Pa
dBd	antenna gain relative to a half-wave dipole
f_{IF}	intermediate frequency
f_{lo}	frequency of the local oscillator signal

3.3 Abbreviations

For the purposes of the present document, the following abbreviations apply:

AC	Alternating Current
ad	amplitude difference
AIS	Automatic Identification System
ARQ	Automatic Response reQuest
DC	Direct Current
DSC	Digital Selective Calling
EMC	ElectroMagnetic Compatibility
emf	electromotive force
EUT	Equipment Under Test
fd	frequency difference
FEC	Forward Error Correction
FM	Frequency Modulation
FSI	Frequency Set Information
GMDSS	Global Maritime Distress and Safety System
IF	Intermediate Frequency
IMO	International Maritime Organization
MF/HF	Medium Frequency/High Frequency
MPFD	Maximum Permitted Frequency Deviation
MUS	Maximum Usable Sensitivity
NBDP	Narrow Band Direct Printing
pd	potential difference

PSTN	Public Switched Telephone Network
RBW	Reference Bandwidth
RF	Radio Frequency
rms	root mean square
SER	Symbol Error Rate
SINAD	Signal + Noise + Distortion/Noise + Distortion
sr	switching range
VDR	Voyage Data Recorder
VHF	Very High Frequency

4 General requirements

4.1 Construction

The manufacturer shall declare compliance to the requirements of this clause (clause 4) and shall provide relevant documentation.

The mechanical and electrical construction and finish of the equipment shall conform in all respects to good engineering practice, and the equipment shall be suitable for use on board ships.

All controls shall be of sufficient size to enable the usual control functions to be easily performed and the number of controls should be the minimum necessary for simple and satisfactory operation.

All parts of the equipment to be checked during inspection or maintenance operations shall be readily accessible. The components shall be readily identifiable.

Technical documentation shall be supplied with the equipment.

The equipment, which may consist of more than one unit, shall be capable of operating on single frequency (simplex) and two-frequency (receiving and transmitting channel separation of 4,6 MHz) as defined in the Radio Regulations, Appendix 18 [4]. The two-frequency operation may be implemented either with manual control (semi-duplex) or without manual control (duplex).

The equipment shall be able to operate on appropriate channels as defined in Appendix 18 to the Radio Regulations [4], noting in particular footnotes a), m) and e). The usage of channels identified by footnote w), wa), ww) and x) analogue voice communication shall be selectable for operation.

If 12,5 kHz channels are implemented in the equipment it shall be in accordance with Recommendation ITU-R M.1084-5 [14].

Additional VHF channels for maritime use outside those defined by Appendix 18 to the Radio Regulations [4] may also be provided where permitted by relevant administrations. These channels shall be clearly identified for use as relating to the relevant administration(s) and accessed through a positive action(s) for enabling use of these channel(s) but means shall be provided to block any or all of these additional channels if required by the relevant administration(s).

The equipment shall be so designed that use of channel 70 for purposes other than DSC is prevented (signalling on channel 70 shall conform with Recommendations ITU-R M.493-15 [5] and M.541-10 [6]), and that use of channels AIS1 and AIS2 for purposes other than AIS is prevented.

It shall not be possible to transmit while any frequency synthesizer used within the transmitter is out of lock.

It shall not be possible to transmit during channel switching operations.

In addition, the equipment shall comply with the applicable general requirements contained in IMO Resolution 694 (17) [1].

4.2 DSC operation

Regarding DSC operation the present document only deals with equipment having integrated or associated DSC encoder/decoder.

If the radio equipment under test is intended for DSC operation in connection with an external DSC encoder/decoder, compliance with the present document can only be achieved, if the manufacturer supplies the test house with the specific stand-alone DSC encoder/decoder, intended for DSC operation, in connection with the radio equipment under test. The radio equipment and the external DSC encoder/decoder shall then be tested as a fully integrated DSC equipment in accordance with clauses 11 and 13.

It shall be notified in the test report, that the tests carried out only secure compliance to the present document, if the specific radio equipment along with the specific DSC encoder/decoder is used together as integrated equipment.

Interfaces for external DSC encoder/decoder are not mandatory.

If interfaces for external DSC encoder / decoder are provided then they shall be in compliance with clauses 5.4.2 and 5.4.3.

4.3 Controls and indicators

The equipment shall have a channel selector and shall indicate the designator of the selected channel, as shown in Appendix 18 to the ITU Radio Regulations [4]. The channel designator shall be legible irrespective of external lighting conditions and provide up to 4 digits to identify the selected channel number as defined in Recommendation ITU-R M.1084-5 [14].

Channel 16 shall be distinctively marked. Selection of channel 16 shall be by readily accessible means (e.g. a distinctively marked key allowing channel 16 to be selected by a single operator action). There shall be a distinctive indication when channel 70 is selected automatically for DSC operation.

Where an input panel on the equipment for entering the digits 0 to 9 is provided, this shall conform to Recommendation ITU-T E.161 [21].

The equipment shall have the following additional controls and indicators (see IMO Resolution A.803(19) [3]):

- a) on/off switch for the entire installation with a visual indication that the installation is in operation;
- b) manual non-locking press-to-talk switch to activate the transmitter;
- c) visual indication that the transmitter is activated;
- d) switch for reducing transmitter output power to no more than 1 W;
- e) on/off switch for the loudspeaker, if a telephone handset is also provided;
- f) audio volume control;
- g) squelch control;
- h) brightness control for reducing the equipment illumination to zero except that those warning and alarm indicators which are illuminated in the warning/alarm condition and indicators required for switching on/off or resetting the equipment or for the initiation of distress alerting shall be clearly visible in all appropriate conditions of ambient illumination.

The equipment shall also meet the following requirements:

- i) the user shall not have access to any control which, if wrongly set, might impair the technical characteristics of the equipment;
- j) if the equipment may be controlled from two or more control consoles, then one of the consoles shall have priority over the others. The operation of one console shall be indicated on all other consoles.

4.4 Handset and loudspeaker

The equipment shall be fitted with a telephone handset or microphone, and an integral loudspeaker or a socket for an external loudspeaker. A handset is required if duplex operation is provided.

It shall be possible to switch off the loudspeaker without causing a variation in the volume provided to the handset.

In simplex operation the receiver's audio output shall be muted during transmission. In duplex operation only the handset shall be operative, to ensure correct operation and to prevent harmful electrical or acoustic feedback which might produce oscillations.

4.5 Safety precautions

The equipment shall be protected against the effects of overcurrent and overvoltage.

The equipment shall be protected against damage due to accidental reversal of polarity of the power supply.

Means shall be provided for earthing exposed metallic parts of the equipment, but this shall not cause any terminal of the source of electrical energy to be earthed.

All components and wiring in which the DC or AC voltage (other than radio-frequency voltage), produce, singly or in combination, peak voltages in excess of 50 V, shall be protected against any accidental access and shall be automatically isolated from all electrical power sources if the protective covers are removed. Alternatively, the equipment shall be constructed in such a way as to prevent access to components operating at such voltages unless an appropriate tool such as a nut-spanner or screwdriver is used. Conspicuous warning labels shall be affixed both inside the equipment and on the protective covers.

No damage to the equipment shall occur when the antenna port is terminated with an open circuit or a short circuit for a period of at least five minutes in each case.

In order to provide protection against damage due to build-up of static charge at the antenna terminals, there shall be a DC path from the antenna terminals to chassis not exceeding 100 k Ω .

The information in any volatile memory device shall be protected from 3 consecutive interruptions in the power supply of up to 60 s duration as described in IEC 61000-4-11 [16].

4.6 Labelling

All controls, instruments, indicators and terminals shall be clearly labelled (see IMO Resolution A.803(19) [3]).

Details of the power supply which the equipment is intended to operate from shall be clearly indicated on the equipment.

All units of the equipment shall be clearly marked on the exterior with the identification of the manufacturer, the type designation of the equipment, and the serial number of the unit.

The compass safe distance shall be clearly marked on the equipment or stated in the user documentation supplied with the equipment.

4.7 Warm up

After being switched on the product shall, as soon as possible and within 5 s clearly indicate that it has been turned on and is initializing.

The channel indicator and/or idle display shall not indicate readiness until the product is fully operational.

The product and any additional controller units shall be fully operational within 1 minute.

4.8 Audio Processing

The equipment may be designed with an audio processing system for best perceived sound quality in the built-in speaker system.

It shall be possible to disable audio processing and it shall be clearly indicated whether audio processing is turned on or off. The best audio quality settings shall be provided automatically after power-on.

If audio processing is applied to the microphone input, the testing shall be performed with the processing enabled.

Audio processing may be applied to audio outputs for handset, external speaker, etc., but shall not affect line level audio interfaces (VDR, etc.).

The overall acoustic design shall be optimized for perceived speech recognition for communication and shall be designed in accordance with clause 4.1.

Where audio processing is activated it shall be assessed that the acoustic speech recognition is equal to, or better than without audio processing enabled when the receiver is operating at its maximum usable sensitivity level.

Under receive conditions below sensitivity level, the acoustic speech recognition shall never be significantly decreased by enabling of audio processing.

5 Technical requirements

5.1 Switching time

The channel switching arrangement shall be such that the time necessary to change over from using one channel to using any other channel does not exceed 5 s.

The time necessary to change over from transmission to reception or vice versa, shall not exceed 0,3 s.

5.2 Class of emission and modulation characteristics

The equipment shall use phase modulation, G3E (frequency modulation with a pre-emphasis of 6 dB per octave) for speech (see Recommendation ITU-R M.489-2 [18]) and G2B for DSC signalling.

The equipment shall be designed to operate satisfactorily with channel separations of 25 kHz, or both 12,5 kHz and 25 kHz.

5.3 Multiple watch facilities

5.3.1 Additional performance standards

VHF radiotelephone equipment having multiple watch facilities shall comply with the following additional performance standards (see IMO Resolution A.524(13) [i.1]):

- a) the equipment may include provision for the automatic scanning of a priority channel and one additional channel. If this facility is included then it shall meet the following requirements. Facilities for the automatic sequential change of the additional channel may be provided, which are not accessible to the user. Means shall be provided to enable/disable this facility;
- b) the priority channel is that channel which will be sampled even if there is a signal on the additional channel and on which the receiver will lock during the time a signal is detected;
- c) the additional channel is that channel which will be monitored during the periods the equipment is not sampling or receiving signals on the priority channel;
- d) provision shall be included to switch the scanning facility on and off by means of a manually operated control. In addition it shall be ensured that the receiver remains on the same channel as the transmitter for the entire duration of any communication with the ship, e.g. the scanning facility could be switched off automatically when the handset is off its hook;
- e) selection of the additional channel and selection of the priority channel shall be possible at the operating position;
- f) when the scanning facility is in operation, the channel number of both channels on which the equipment is operating shall be clearly indicated simultaneously;

- g) in a transceiver, transmission shall not be possible when the scanning facility is operating. When the scanning facility is switched off, both transmitter and receiver shall be tuned automatically to the selected additional channel;
- h) a transceiver shall be provided with a single manual control (e.g. push-button) in order to switch the equipment quickly for operation on the priority channel;
- i) at the operating position of a transceiver the selected additional channel shall be clearly indicated as being the operational channel of the equipment.

5.3.2 Scanning characteristics

When the scanning facility is switched on, the priority channel shall be sampled with a sampling period of not more than 2 s. If a signal is detected on the priority channel the receiver shall remain on this channel for the duration of that signal.

If a signal is detected on the additional channel the sampling of the priority channel shall continue, thus interrupting the reception on the channel for periods as short as possible and not greater than 150 ms.

The design of the receiver shall provide for its proper functioning during the period the priority channel is sampled since the receiving conditions on the priority channel may differ from those on the additional channel.

In the absence of a signal on the priority channel, and, during reception of a signal on the additional channel, the duration of each listening period on this channel shall be at least 850 ms.

Means shall be provided to indicate the channel on which a signal is being received.

5.4 Interfaces

5.4.1 General

The interfaces described in clauses 5.4.2 and 5.4.3 below shall be provided. Other interfaces may be provided but it is required that they do not have in any case an impact which could degrade the performance of the equipment.

5.4.2 Audio frequency

Transmitter:

- Microphone input
- 600 Ω earth free line input

Receiver:

- Earphone output
- Loudspeaker output
- 600 Ω earth free line output (0 dBm \pm 3 dB)

The line input/output are not mandatory.

5.4.3 Digital interfaces

- External 2-wire transmitter key input, closure to transmit.
- Control interface:
 - The interface for control complying with IEC 61162-1 [10].
 - The control protocol including Frequency Set Information (FSI) (see annex B).

These digital interfaces are not mandatory for equipment with an integrated DSC controller.

5.5 Voyage data recorder interface

To facilitate the connection of separate VDR equipment, a single audio output port shall be provided, with a characteristic impedance of 600 Ω , symmetrical and free of earth, on which combined transmit and receive audio shall be present. The available power shall be 0 dBm \pm 3 dB using normal test modulation defined in clauses 7.5 and 7.8.

6 Test conditions, power sources and ambient temperatures

6.1 Test conditions

Tests shall be carried out under normal test conditions and also, where stated, under extreme test conditions.

Tests under normal test conditions shall be carried out using the normal power source voltage as defined in clause 6.3.2 under conditions of normal temperature and humidity as defined in clause 6.3.1.

Tests under extreme test conditions shall be carried out using extreme values of power source voltage as defined in clause 6.4.2 at the extremes of temperature defined in clause 6.4.1.

6.2 Test power source

During testing, the equipment shall be supplied from a test power source capable of producing the necessary supply voltages.

The internal impedance of the test power source shall be low enough for its effect on the test results to be negligible. The power source voltage shall be measured at the input terminals of the equipment, and during testing this voltage shall be maintained within a tolerance of ± 3 % relative to the voltage level at the beginning of each test.

6.3 Normal test conditions

6.3.1 Normal temperature and humidity

The normal temperature and humidity conditions for test shall be any combination of temperature and humidity within the following ranges:

- temperature: +15 °C to +35 °C;
- relative humidity: 20 % to 75 %.

The test conditions shall be recorded in the test report.

6.3.2 Normal power source voltage

6.3.2.1 Mains powered equipment

The normal power source voltage for equipment intended to be connected to the AC mains shall be any one of the nominal mains voltages with which the equipment is declared by the manufacturer to be compatible. The power source frequency shall be the nominal frequency with which the equipment is declared by the manufacturer to be compatible.

6.3.2.2 Battery powered equipment

Where equipment is intended to operate from a battery, the normal power source voltage shall be the nominal voltage of the battery as declared by the manufacturer.

6.3.2.3 Other power sources

For operation from other power sources the normal power source voltage shall be that declared by the manufacturer.

6.4 Extreme test conditions

6.4.1 Extreme temperatures

For tests at extreme temperatures measurements shall be made, in accordance with clause 6.5, at a lower temperature of $-15\text{ }^{\circ}\text{C}$ and at an upper temperature of $+55\text{ }^{\circ}\text{C}$.

6.4.2 Extreme values of power source voltage

6.4.2.1 Mains powered equipment

The extreme values of power source voltage and frequency for equipment intended to be connected to the AC mains shall be the nominal mains voltage $\pm 10\%$ and the nominal power source frequency $\pm 1\text{ Hz}$.

6.4.2.2 Battery powered equipment

Where equipment is intended to operate from a battery, the upper and lower extreme values of power source voltage shall be 1,3 times and 0,9 times the nominal voltage of the battery as declared by the manufacturer.

6.4.2.3 Other power sources

For operation from other power sources the extreme values of power source voltage shall be agreed between the regulatory authority and the manufacturer.

6.5 Procedure for tests at extreme temperatures

For tests at the upper extreme of temperature, the EUT shall be placed in the test chamber and left switched off until thermal equilibrium is reached. The EUT shall then be switched on for half an hour in the high power transmit condition. At the end of this transmit period the necessary tests shall be carried out immediately.

For tests at the lower extreme of temperature, the EUT shall be placed in the test chamber and left switched off until thermal equilibrium is reached. The EUT shall then be switched to the standby or receive position for one minute. At the end of this one minute period the necessary tests shall be carried out immediately.

7 General conditions of measurement

7.1 Sequence of testing

Testing may be carried out on either one or two samples of the product, at the manufacturer's discretion.

Where one sample is used, environmental tests shall be carried out first, before tests are performed on the same equipment with respect to the other requirements of the present document.

Where two samples (sample A and sample B) are used, environmental tests shall be carried out on sample A, while sample B shall undergo the same pre-conditioning, i.e. vibration including any endurance tests, dry heat cycle, damp heat cycle, low temperature cycle - as sample A, but without the requirement to be subjected to performance checks during the pre-conditioning.

Following environmental tests/pre-conditioning both samples shall be subject to performance checks. If either sample should fail the performance checks this shall constitute an environmental test failure.

Emissions and immunity tests shall be carried out on sample B after environmental pre-conditioning.

Tests with respect to the other requirements of the present document shall be carried out on sample A after environmental tests are completed.

7.2 Test channels

For analogue speech, tests shall be made on channel 16 unless otherwise stated. For DSC, tests shall be made on channel 70 unless otherwise stated.

7.3 Squelch

Unless otherwise specified, the receiver's squelch facility shall be made inoperative for the duration of testing.

7.4 Arrangements for test signals applied to the receiver input

Test signal sources shall be connected to the receiver in such a way that the EUT receiver RF input port is terminated with a non-reactive 50 Ω impedance, irrespective of whether one or more test signals are applied to the receiver simultaneously.

Where a wanted test signal is specified, the test signal source shall be set to supply a test signal on the nominal frequency of the test channel, as selected on the EUT receiver.

Test signals levels are expressed throughout the present document in terms of the emf at the terminals to be connected to the EUT receiver RF input port. Care shall be taken to determine whether level information displayed on test equipment is in terms of pd or emf, and to convert accordingly.

7.5 Normal test modulation of the receiver wanted signal

For the purposes of the present document, normal test modulation of the wanted test signal applied to the EUT receiver shall be modulation by a sinusoidal audio signal as follows:

- 25 kHz channels: 1 kHz and the frequency deviation shall be ± 3 kHz.
- 12,5 kHz channels: 1 kHz and the frequency deviation shall be $\pm 1,5$ kHz.

7.6 Arrangements for monitoring the receiver output

The EUT receiver shall be connected to the measuring equipment in such a way that EUT receiver analogue speech output port operates into a resistive load which simulates the receiver's normal operating load (the value of this load shall be stated by the manufacturer).

Where audio processing is available, it shall be disabled for all receiver tests (clause 12). The manufacturer shall provide information on how audio processing is disabled.

Unless stated otherwise the EUT receiver volume control shall be set to produce at least 50 % of the rated audio output power.

Unless stated otherwise the audio output signal shall be coupled via a psophometric weighting network conforming to Recommendation ITU-T O.41 [7] to a SINAD measuring instrument and an rms voltmeter having a -6 dB bandwidth of at least 20 kHz.

The EUT receiver DSC output should be monitored by means of the DSC information display. Where a manufacturer supplies additional ancillary equipment to demonstrate DSC capability, this equipment shall be included with the EUT inside the test environment.

7.7 Arrangements for test signals applied to the transmitter input

Unless stated otherwise, a signal generator shall be used to provide the audio frequency signal to modulate the transmitter. The signal generator shall be connected in place of the microphone transducer, and the signal shall be applied to the connection terminals normally used for the microphone transducer.

7.8 Normal test modulation of the transmitter

For the purposes of the present document, normal test modulation of the EUT transmitter shall be modulation by a sinusoidal audio signal as follows:

- 25 kHz channels: 1 kHz and the frequency deviation shall be ± 3 kHz.
- 12,5 kHz channels: 1 kHz and the frequency deviation shall be $\pm 1,5$ kHz.

7.9 Arrangements for monitoring the transmitter output

For transmit mode tests the EUT shall be connected to the measuring equipment in such a way that the EUT transmitter antenna port is terminated with a non-radiating non-reactive 50 Ω impedance.

7.10 Arrangements for test of DSC

Equipment with integrated DSC encoder/decoder is tested according to the present document without any further arrangements.

Where the equipment under test does not include an integrated DSC encoder/decoder refer to clause 4.2.

7.11 Standard test signals for DSC

Standard test signals shall consist of a series of identical call sequences, each of which contain a known number of information symbols: format specifier, address, category, identification, etc., as defined in Recommendation ITU-R M.493-15 [5].

Standard test signals shall be of sufficient length for the measurements to be performed, or it shall be possible to repeat them without interruption to make the measurements.

7.12 Determination of symbol error ratio in the output of the receiver

Equipment with integrated DSC decoder is evaluated by determination of the Symbol Error Rate (SER). The decoded DSC call sequence applied with forward error correction, interleaving techniques and check-sum information is divided into blocks each corresponding to one information symbol in the received signal. The ratio between the number of incorrect blocks to the total number of blocks is determined as the Symbol Error Rate.

Precautions shall be taken to ensure statistically significant results.

7.13 Reference bandwidths for spurious measurements

The reference bandwidths applicable for all spurious measurements are given in Table 1.

Table 1: Reference bandwidths to be used for the measurement of spurious emissions

Frequency range	RBW
9 kHz to 150 kHz	1 kHz
150 kHz to 30 MHz	10 kHz
30 MHz to 1 GHz	100 kHz
Above 1 GHz	1 MHz

7.14 Interpretation of the measurement results

The interpretation of the results recorded in a test report for the measurements described in the present document shall be as follows:

- the measured value related to the corresponding limit will be used to decide whether an equipment meets the requirements of the present document;
- the value of the measurement uncertainty for the measurement of each parameter shall be included in the test report;
- the recorded value of the measurement uncertainty shall be, for each measurement, equal to or lower than the figures in Table 2.

For the test methods, according to the present document, the measurement uncertainty figures shall be calculated and shall correspond to an expansion factor (coverage factor) $k = 1,96$ or $k = 2$ (which provide confidence levels of respectively 95 % and 95,45 % in the case where the distributions characterizing the actual measurement uncertainties are normal (Gaussian)). Principles for the calculation of measurement uncertainty are contained in ETSI TR 100 028-1 [i.4] and ETSI TR 100 028-2 [i.7], in particular in annex D of the ETSI TR 100 028-2 [i.7].

Table 2: Measurement uncertainties: maximum values

Parameter	Maximum uncertainty
RF frequency	$\pm 0,1$ ppm
RF power	$\pm 0,75$ dB
Maximum frequency deviation: <ul style="list-style-type: none"> • within 300 Hz to 6 kHz of audio frequency • within 6 kHz to 25 kHz of audio frequency 	± 5 % ± 3 dB
Adjacent channel power	± 5 dB
Conducted spurious emissions of transmitter	± 4 dB
Audio output power	$\pm 0,5$ dB
Amplitude characteristics of receiver	$\pm 1,5$ dB
Sensitivity at 20 dB SINAD	± 3 dB
Conducted emissions of receiver	± 3 dB
Two-signal measurement	± 4 dB
Three-signal measurement	± 3 dB
Radiated spurious emissions of transmitter	± 6 dB
Radiated spurious emissions of receiver	± 6 dB
Transmitter transient time	± 20 %
Transmitter transient frequency	± 250 Hz
Receiver desensitization (duplex operation)	$\pm 0,5$ dB

8 Performance checks

8.1 Performance checks - introduction

The environmental tests detailed in clause 9 and the immunity tests detailed in EN 60945 [i.6] and ETSI EN 301 843-2 [i.8] rely upon performance checks being carried out upon the EUT as it is subjected to adverse environmental or electromagnetic conditions, in order to determine the ability of the EUT to perform satisfactorily under these conditions.

Performance checks shall be carried out on channel 16. Transmitter checks shall be carried out with output power set at maximum. In all cases performance checks shall comprise the following clauses.

8.2 Performance check - transmitter frequency error

Arrangements for monitoring the transmitter output are specified in clause 7.9. The carrier frequency shall be measured in the absence of modulation.

The frequency error shall be within $\pm 1,5$ kHz (for a definition of frequency error see clause 10.2.1).

8.3 Performance check - transmitter carrier power

Arrangements for monitoring the transmitter output are specified in clause 7.9. The power delivered to the antenna transmission line shall be measured.

The carrier power shall be between 6 W and 25 W (for a definition of carrier power see clause 10.3.1).

8.4 Performance check - transmitter audio frequency harmonic distortion of the emission

Arrangements for modulating the transmitter are specified in clause 7.7. Arrangements for monitoring the transmitter output are specified in clause 7.9. The transmitter shall be modulated with normal test modulation as specified in clause 7.8. The harmonic distortion of the audio frequency signal shall be measured.

The harmonic distortion shall not exceed 10 % (for a definition of audio frequency harmonic distortion see clause 10.7.1).

8.5 Performance check - receiver sensitivity

A wanted test signal at +12 dB μ V emf, modulated by the normal test modulation as specified in clause 7.5, shall be applied to the receiver RF input port as specified in clause 7.4. The receiver output shall be monitored as specified in clause 7.6, the SINAD ratio at the receiver audio output shall be measured.

The SINAD ratio shall be at least 20 dB.

8.6 Performance check of DSC

For the purpose of the present document, the term "performance check" shall be taken to mean:

Regarding receiver

- Check of the MUS level as described in clause 12.3 shall be carried out. The input level shall be 6 dBuV and the decoded symbol error shall be less than 10^{-2} .

Regarding transmitter

- Check of output power as described in clause 11.4.

- Check of frequency error as described in clause 11.2.
- Correct decoding of a transmitted DSC call.

9 Environmental tests

9.1 Procedure

Unless stated otherwise, the equipment shall be connected to an electrical power source during the periods for which it is specified that electrical tests shall be carried out. These tests shall be performed using the normal test voltage.

9.2 Vibration test

9.2.1 Definition

This test verifies the ability of the equipment to withstand vibration without resulting in mechanical weakness or degradation in performance.

9.2.2 Method of measurement

The EUT, complete with any shock and vibration absorbers with which it is provided, shall be clamped to the vibration table by its normal means of support and in its normal attitude. The EUT may be resiliently suspended to compensate for weight not capable of being withstood by the vibration table. Provision may be made to reduce or nullify any adverse effect on EUT performance which could be caused by the presence of an electromagnetic field due to the vibration unit.

The EUT shall be subjected to sinusoidal vertical vibration at all frequencies between:

- 2 Hz to 5 Hz and up to 13,2 Hz with an excursion of $\pm 1 \text{ mm} \pm 10 \%$ (7 metres per second per second maximum acceleration at 13,2 Hz);
- 13,2 Hz to 100 Hz with a constant maximum acceleration of 7 metres per second per second.

The frequency sweep rate shall be 0,5 octaves/minute in order to allow the detection of resonances in any part of the EUT as mounted.

A resonance search shall be carried out throughout the test. During the resonance search the EUT shall be externally observed, by unaided visual and aural means, for obvious signs of any resonances of components or sub-assemblies that may affect the integrity of the EUT. Such observations shall be recorded in the test report. If any resonance, as measured by a sensor fixed to the outside of the EUT at the location where obvious signs of resonance have been observed, has a magnitude ratio ≥ 5 measured relative to the surface where the EUT is fastened, the EUT shall be subjected to a vibration endurance test at each resonant frequency at the vibration level specified in the test with a duration of two hours. When resonant frequencies with magnitude ratios ≥ 5 are harmonically related only the fundamental frequency shall be tested. If no resonance with magnitude ratio ≥ 5 occurs, the endurance test shall be carried out at one single observed frequency. If no resonance occurred, the endurance test shall be carried out at a frequency of 30 Hz.

Performance checks shall be carried out at least once during each endurance test period, and once before the end of each endurance test period.

The procedure shall be repeated with vibration in each of two mutually perpendicular directions in the horizontal plane.

After conducting the vibration tests, the equipment shall be inspected for any mechanical deterioration.

9.2.3 Requirement

The equipment shall meet the requirements of the performance checks defined in clause 8.

There shall be no harmful deterioration of the equipment visible.

9.3 Temperature tests

9.3.1 Introduction

These tests verify the ability of the equipment to withstand extremes of temperature and humidity without resulting in mechanical weakness or degradation in performance.

9.3.2 General procedure

The maximum rate of raising or reducing the temperature of the chamber in which the equipment is being tested shall be 1 °C per minute.

9.3.3 Dry heat

9.3.3.1 Definition

This test verifies the ability of the equipment to be operated at high ambient temperatures and to operate through temperature changes.

9.3.3.2 Method of measurement

The EUT shall be placed in a chamber at normal room temperature and relative humidity. The EUT shall then be switched on, along with any climatic control devices with which it is provided. The temperature shall then be raised to $+55\text{ °C} \pm 3\text{ °C}$ and maintained for a period of 10 hours to 16 hours.

The EUT shall then be subjected to the performance checks. The temperature of the chamber shall be maintained at $+55\text{ °C} \pm 3\text{ °C}$ during the performance check.

At the end of the test, the EUT shall be returned to normal environmental conditions.

9.3.3.3 Requirement

The equipment shall meet the requirements of the performance checks defined in clause 8.

9.3.4 Damp heat

9.3.4.1 Definition

This test verifies the ability of the equipment to be operated under conditions of high humidity.

9.3.4.2 Method of measurement

The EUT shall be placed in a chamber at normal room temperature and relative humidity. The temperature shall be raised to $+40\text{ °C} \pm 2\text{ °C}$, and the relative humidity raised to $93\% \pm 3\%$ over a period of three hours $\pm 0,5$ hour. These conditions shall then be maintained for a period of 10 hours to 16 hours.

Any climatic control devices provided in the EUT may be switched on at the end of this period. The EUT shall be switched on thirty minutes later, or after such period as agreed by the manufacturer, and shall be kept operational for at least two hours during which period the EUT shall be subjected to the performance checks. The temperature and relative humidity of the chamber shall be maintained at $+40\text{ °C} \pm 2\text{ °C}$ and $93\% \pm 3\%$ respectively during the performance checks.

At the end of the test period and with the EUT still in the chamber, the chamber shall be brought to room temperature in not less than one hour, and the EUT shall then be returned to normal environmental conditions.

9.3.4.3 Requirement

The equipment shall meet the requirements of the performance checks defined in clause 8.

9.3.5 Low temperature cycle

9.3.5.1 Definition

These tests verify the ability of the equipment to be operated at low temperatures, and to start up at low ambient temperatures.

9.3.5.2 Method of measurement

The EUT shall be placed in a chamber at normal room temperature and relative humidity. The temperature shall then be reduced to $-15\text{ °C} \pm 3\text{ °C}$, and maintained for a period of 10 hours to 16 hours.

Any climatic control devices provided in the EUT may be switched on at the end of this period. The EUT shall be switched on thirty minutes later, and shall be kept operational for at least two hours during which period the EUT shall be subjected to the performance checks. The temperature of the chamber shall be maintained at $-15\text{ °C} \pm 3\text{ °C}$ during the performance checks.

At the end of the test the EUT shall be returned to normal environmental conditions.

9.3.5.3 Requirement

The equipment shall meet the requirements of the performance checks defined in clause 8.

Precautions shall be taken to avoid or minimize any effects upon the test due to the coupling means employed.

10 Transmitter

10.1 General conditions

All tests on the transmitter shall be carried out with output power set at maximum, except where otherwise stated.

10.2 Frequency error

10.2.1 Definition

Frequency error is the difference between the measured carrier frequency and its nominal value.

10.2.2 Method of measurement

Arrangements for monitoring the transmitter output are specified in clause 7.9. The carrier frequency shall be measured in the absence of modulation.

Measurements shall be made with the output power set at maximum and also with the output power set at minimum.

This test shall be carried out under normal test conditions and under extreme test conditions, as specified in clauses 6.3 and 6.4 respectively.

10.2.3 Limits

The frequency error shall be within $\pm 1,5$ kHz.

10.3 Carrier power

10.3.1 Definitions

Carrier power is the mean power delivered to the antenna transmission line during one radio frequency cycle in the absence of modulation.

Maximum output power shall be the rated output power declared by the manufacturer.

10.3.2 Method of measurement

Arrangements for monitoring the transmitter output are specified in clause 7.9. The power delivered to the antenna transmission line shall be measured with the output power set at maximum and repeated with the output power set at minimum.

Measurements shall be made on channel 16, and also on the highest frequency and lowest frequency.

This test shall be carried out under normal test conditions and under extreme test conditions, as specified in clauses 6.3 and 6.4 respectively.

10.3.3 Limits

10.3.3.1 General

The limits prescribed in clauses 10.3.3.2 and 10.3.3.3 apply to channel 16, and to any 25 KHz channels for shipboard transmission of the VHF maritime mobile band, as defined in Appendix 18 to the ITU Radio Regulations [4].

10.3.3.2 Normal test conditions limits

Measured under normal test conditions with the output power set at maximum, the carrier power shall be between 6 W and 25 W, and shall not differ by more than 1,5 dB from the rated output power as declared by the manufacturer. The output power shall never however exceed 25 W.

Measured under normal test conditions with the output power set at minimum, the carrier power shall be between 0,1 W and 1 W.

10.3.3.3 Extreme test conditions limits

Measured under extreme test conditions with the output power set at maximum, the carrier power shall remain between 6 W and 25 W, and shall be within +2 dB, -3 dB of the rated output power as declared by the manufacturer. The output power shall never however exceed 25 W.

Measured under extreme test conditions with the output power set at minimum, the carrier power shall remain between 0,1 W and 1 W.

10.4 Frequency deviation

10.4.1 Definition

Frequency deviation is the difference between the instantaneous frequency of the modulated radio frequency signal and the carrier frequency.

10.4.2 Maximum permissible frequency deviation

10.4.2.1 Method of measurement

Arrangements for modulating the transmitter are specified in clause 7.8. Arrangements for monitoring the transmitter output are specified in clause 7.9.

The transmitter shall be modulated with an audio tone at a level 20 dB above that required to produce normal test modulation as specified in clause 7.8. The frequency of this tone shall then be varied between 100 Hz and 3 kHz while its level is kept constant.

The peak frequency deviation shall be measured over this range.

Measurements shall be made with the output power set at maximum and also with the output power set at minimum.

10.4.2.2 Limits

The maximum permissible peak frequency deviation shall be:

- 25 kHz channels: ± 5 kHz.
- 12,5 kHz channels: $\pm 2,5$ kHz.

10.4.3 Reduction of frequency deviation at modulation frequencies above 3 kHz

10.4.3.1 Method of measurement

Arrangements for modulating the transmitter are specified in clause 7.8. Arrangements for monitoring the transmitter output are specified in clause 7.9.

The transmitter shall be modulated with an audio tone at a level required to produce normal test modulation as specified in clause 7.8. The frequency of this tone shall then be varied between 3 kHz (see note) and a frequency equal to the channel separation for which the equipment is intended while its level is kept constant.

The peak frequency deviation shall be measured over this range.

NOTE: 2,55 kHz for transmitters intended for 12,5 kHz channel separation.

10.4.3.2 Limits

The frequency deviation at modulation frequencies between 3,0 kHz (for equipment operating with 25 kHz channel separations) or 2,55 kHz (for equipment operating with 12,5 kHz channel separation) and 6,0 kHz shall not exceed the frequency deviation at a modulation frequency of 3,0 kHz/2,55 kHz. At 6,0 kHz the deviation shall be not more than 30,0 % of the maximum permissible frequency deviation.

The frequency deviation at modulation frequencies between 6,0 kHz and a frequency equal to the channel separation for which the equipment is intended shall not exceed that given by a linear representation of the frequency deviation (dB) relative to the modulation frequency, starting at the 6,0 kHz limit and having a slope of -14,0 dB per octave. These limits are illustrated in Figure 2.

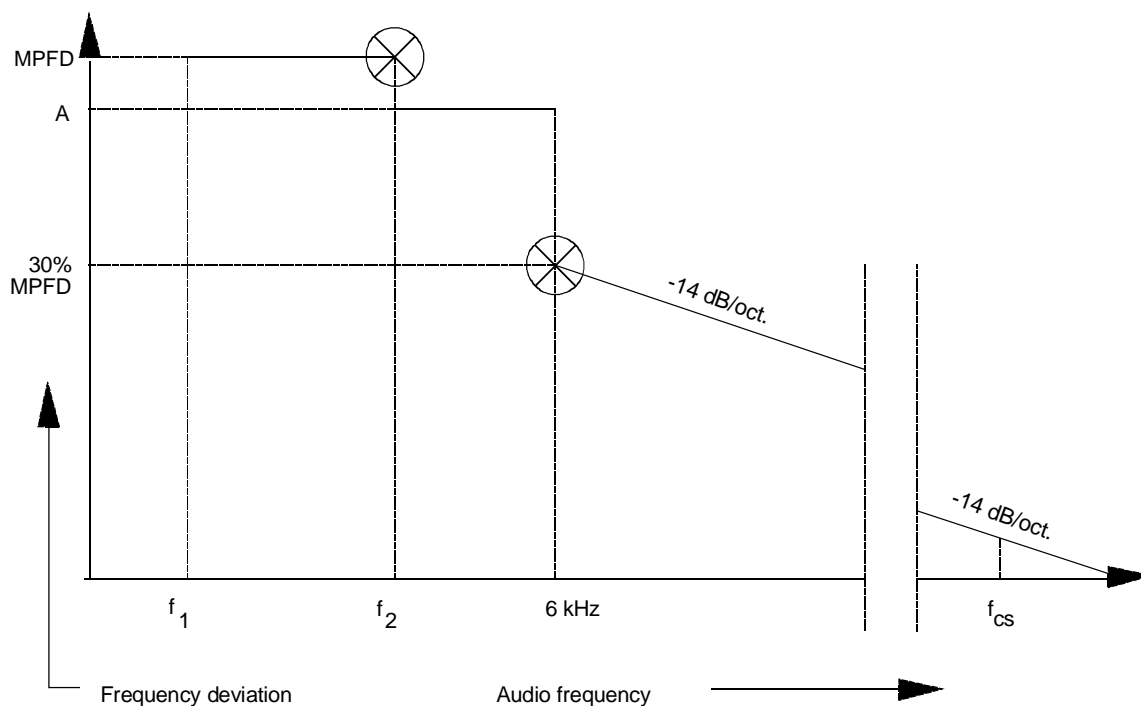

NOTE:

Abbreviations:

- f_1 lowest appropriate frequency
 f_2 3,0 kHz (for 25 kHz channel separation), or
 2,55 kHz (for 12,5 kHz channel separation)
 MPFD maximum permissible frequency deviation (see clause 10.4.1)
 A measured frequency deviation at f_2
 f_{cs} frequency equal to channel separation

Figure 2: Frequency deviation limits

10.5 Sensitivity of the modulator including the microphone

10.5.1 Definition

This measurement characterizes the capability of the transmitter to produce sufficient modulation when an audio signal corresponding to the normal mean speech level is applied to the microphone.

10.5.2 Method of measurement

An acoustic signal with a frequency of 1 kHz and a sound level of 94 dBA shall be applied to the EUT microphone. The resulting peak frequency deviation shall be measured.

10.5.3 Limits

The frequency deviation shall be in the ranges $\pm 1,5$ kHz to ± 3 kHz.

10.6 Audio frequency response

10.6.1 Definition

The audio frequency response is the peak frequency deviation of the transmitter as a function of the modulating frequency.

10.6.2 Method of measurement

Arrangements for modulating the transmitter are specified in clause 7.8. Arrangements for monitoring the transmitter output are specified in clause 7.9.

A modulating tone at 1 kHz shall be applied to the transmitter and the audio input level shall be adjusted so that the peak frequency deviation of the transmitter is ± 1 kHz. This is the reference point in Figure 3 (i.e. 1 kHz corresponds to 0 dB).

The modulating tone shall then be varied between 300 Hz and 3 kHz (see note), while its level is kept constant. The peak frequency deviation shall be measured over this range.

NOTE: 2,55 kHz for transmitters intended for 12,5 kHz channel separation.

10.6.3 Limits

The audio frequency response shall be within +1 dB and -3 dB of a 6 dB per octave line passing through the reference point, as shown in Figure 3. The upper limit frequency shall be 2,55 kHz for 12,5 kHz channels.

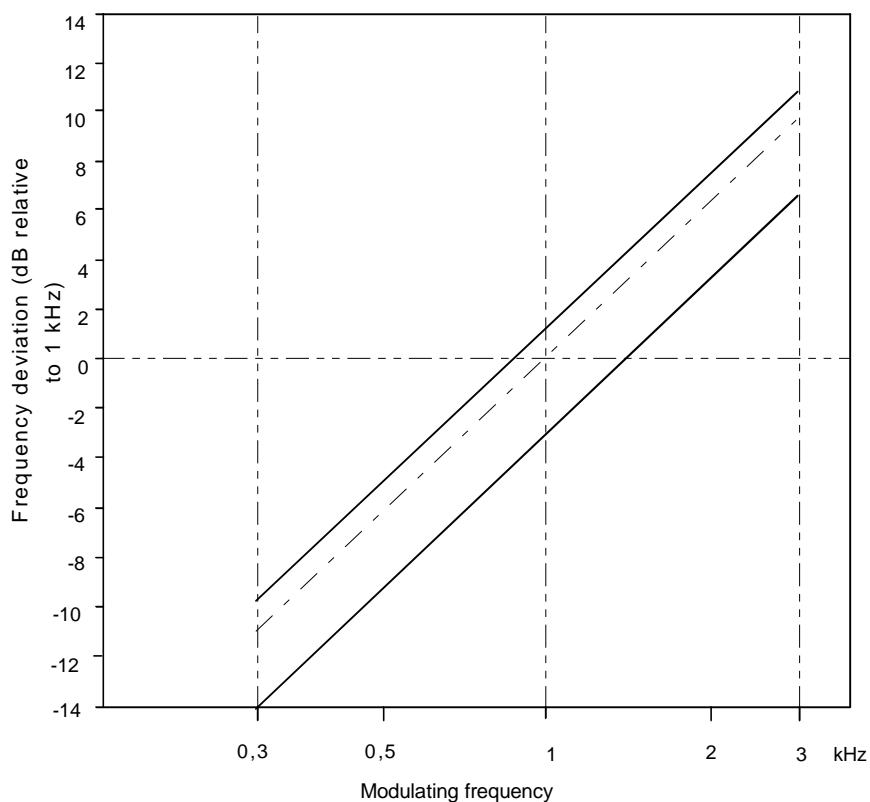

Figure 3: Transmitter modulating frequency response limits

10.7 Audio frequency harmonic distortion of the emission

10.7.1 Definition

Harmonic distortion of the emission, with the transmitter modulated by an audio tone, is a parameter of the recovered audio signal after linear demodulation of the transmitter output, and is defined as the percentage ratio of the rms voltage of all the harmonics (of the audio tone fundamental frequency) within the recovered audio signal to its total rms voltage.

10.7.2 Method of measurement

Arrangements for modulating the transmitter are specified in clause 7.8. Arrangements for monitoring the transmitter output are specified in clause 7.9.

Measurements shall be made with the transmitter output power setting at maximum and repeated with the transmitter output power setting at minimum.

This test shall be carried out under normal test conditions and under extreme test conditions, as specified in clauses 6.3 and 6.4 respectively.

Under normal test conditions the transmitter shall be modulated with audio tones at 300 Hz, 500 Hz and 1 kHz successively, with a constant modulation index of 3. The distortion of the audio frequency signal shall be measured in each case.

Under extreme test conditions the transmitter shall be modulated with an audio tone at 1 kHz, with a modulation index of 3. The distortion of the audio tone shall be measured.

10.7.3 Limits

The harmonic distortion shall not exceed 10 %.

10.8 Adjacent channel power

10.8.1 Definition

The adjacent channel power is that part of the total power output of a transmitter, under defined conditions of modulation, which falls within a specified passband centred on the nominal frequency of either of the adjacent channels.

10.8.2 Method of measurement

Measurements shall be made on channel 16, and also on the highest frequency and lowest frequency channels.

The adjacent channel power shall be measured with a power measuring receiver which conforms to annex A, (in the following referred to as "the receiver"):

- a) Arrangements for coupling the transmitter RF output to the "receiver" are specified in clause 7.9.
- b) With the transmitter unmodulated, the tuning of the "receiver" shall be adjusted so that a maximum response is obtained. This is the 0 dB response point. The "receiver" attenuator setting and the reading of the meter shall be recorded.
- c) The measurement may be made with the transmitter modulated with normal test modulation, in which case this fact shall be recorded with the test results.
- d) The tuning of the "receiver" shall be adjusted away from the carrier so that the "receiver" -6 dB response nearest to the transmitter carrier frequency is located at a displacement from the nominal carrier frequency of 17 kHz for 25 kHz channels or 8,25 kHz for 12,5 kHz channels.
- e) The transmitter shall be modulated with 1,25 kHz at a level which is 20 dB higher than that required to produce ± 3 kHz deviation for 25 kHz channels or $\pm 1,5$ kHz deviation for 12,5 kHz channels.
- f) The "receiver" variable attenuator shall be adjusted to obtain the same meter reading as in step b) or a known relation to it.
- g) The ratio of adjacent channel power to carrier power is the difference between the attenuator settings in steps b) and f), corrected for any differences in the reading of the meter.
- h) The measurement shall be repeated with the "receiver" tuned to the other side of the carrier.

10.8.3 Limits

The adjacent channel power shall not exceed a value of:

- 25 kHz channel: 70 dB below the carrier power of the transmitter, or 0,2 μ W whichever is the greater.
- 12,5 kHz channel: 60 dB below the carrier power of the transmitter, or 0,2 μ W whichever is the greater.

10.9 Conducted spurious emissions conveyed to the antenna

10.9.1 Definition

Conducted spurious emissions from the transmitter are emissions present at the transmitter RF output port on frequencies which are outside the necessary bandwidth, the level of which may be reduced without affecting the transmission of information; these include harmonic emissions, parasitic emissions, intermodulation products and frequency conversion products, but exclude out of band emissions.

10.9.2 Method of measurement

The transmitter is connected to the artificial antenna as described in clause 7.9.

The measurement is made on channel 16 and the transmitter at maximum power and unmodulated.

The level of spurious emissions shall be measured as the power level of any discrete signal appearing at the transmitter output. The measurement shall be made in the range from 9 kHz to 2 GHz excluding the channel on which the transmitter is operating and its adjacent channels.

10.9.3 Limit

The power of the conducted spurious emissions shall not exceed the limits in Table 3.

Table 3: Power limits for conducted spurious emissions

Frequency Range	Mean power, in the reference bandwidth (see clause 7.13)
$9 \text{ kHz} \leq f \leq 1 \text{ GHz}$	-36 dBm
$1 \text{ GHz} < f \leq 2 \text{ GHz}$	-36 dBm

NOTE: f is the frequency of the spurious domain emission.

10.10 Residual modulation of the transmitter

10.10.1 Definition

The residual modulation of the transmitter is the ratio, in dB, of the demodulated RF signal in the absence of wanted modulation, to the demodulated RF signal produced when the normal test modulation is applied.

10.10.2 Method of measurement

Arrangements for modulating the transmitter are specified in clause 7.8. Arrangements for monitoring the transmitter output are specified in clause 7.9.

Precautions shall be taken to avoid the effects of emphasizing the low audio frequencies produced by internal noise.

The transmitter shall be modulated with normal test modulation as specified in clause 7.8, and the recovered audio signal level shall be measured.

The modulation shall then be switched off and the recovered audio signal level shall be measured again.

10.10.3 Limit

The residual modulation shall not exceed -40 dB on either 12,5 kHz or 25 kHz channels.

10.11 Transient frequency behaviour of the transmitter

10.11.1 Definition

The transient frequency behaviour of the transmitter is the variation of the transmitter frequency from the nominal frequency, with time, when the RF output power is switched on and off.

10.11.2 Method of measurement

In order to define the method of measurement, the following definitions will apply:

- t_{on} the switch-on instant, defined as the instant when the output power, measured at the transmitter antenna port, exceeds 0,1 % of the nominal power;
- t_1 the period of time starting at t_{on} and ending 5 ms later;
- t_2 the period of time starting at the end of t_1 and ending 20 ms later;
- t_{off} the switch-off instant, defined as the instant when the output power, measured at the transmitter antenna port, falls below 0,1 % of the nominal power;
- t_3 the period of time ending at t_{off} and starting 5 ms earlier.

Arrangements for monitoring the transmitter output are shown in Figure 4: the transmitter output is connected via a 50 Ω power attenuator to the first input of a combining network, and a test signal generator is connected to the second input.

The output of the combining network is connected to the RF input of a FM-demodulator. The arrangements shall be such that all ports are presented with a 50 Ω non-reactive termination.

The output of the FM-demodulator, representing the difference between the instantaneous frequency of the combined input and the nominal frequency of the test channel (the frequency difference f_d), is connected to a storage oscilloscope for display.

A signal corresponding to the amplitude of the combined RF input to the FM-demodulator (the amplitude difference a_d) has to be derived and connected to trigger the storage oscilloscope. Typically the storage oscilloscope is set to a sweep rate of 10 ms/division, and set to trigger at 1 division from the left edge of the display.

With the EUT transmitter inactive the test signal generator is set to the nominal frequency of the transmitter, and modulated with a 1 kHz tone to a peak deviation of ± 25 kHz. The level of the test signal is set to 30 dB below the level of the EUT transmitter in the combined signal. This level is then maintained throughout the measurement.

With the oscilloscope on free running trigger, adjustments can be made at this point to centre and calibrate the vertical scale in terms of frequency deviation, since the displayed 1 kHz sinewave of the demodulated test signal represents a peak-to-peak deviation of 50 kHz around the nominal channel frequency.

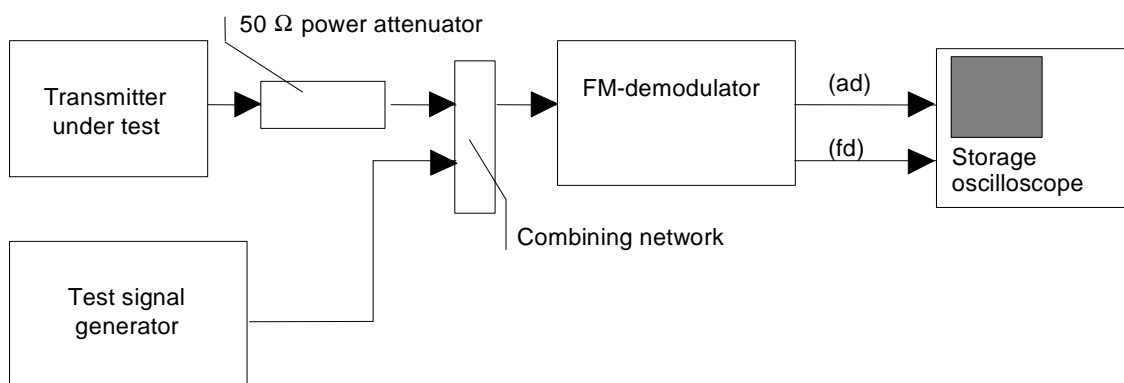

Figure 4: Transient frequency behaviour test configuration

With the above test configuration and calibration complete, the storage oscilloscope is set up to trigger on the ad signal at a level slightly greater than that produced by the test signal.

The transmitter is then switched on, without modulation: as a result the oscilloscope will trigger and a trace will be captured on the display.

The rising power of the transmitter signal will capture the FM-demodulator as its amplitude exceeds that of the test signal; the moment when this happens corresponds to t_{on} as defined above, and this moment is readily identifiable on the trace by the complete suppression of the 1 kHz sine wave of the demodulated test signal.

On the trace everything after t_{on} shows the frequency difference of the transmitter over time as it settles towards the nominal channel frequency.

The above procedure will capture the transmitter transient frequency behaviour at switch-on. To capture the transient frequency behaviour at switch-off the storage oscilloscope is set up to trigger on the decaying ad signal at a level slightly less than that produced by the transmitter signal, and the transmitter is switched off.

The moment t_{off} as defined above is identified on the trace as the point at which the 1 kHz sine wave of the demodulated test signal begins to rise, signifying that the test signal has captured the FM-demodulator as its amplitude exceeds that of the transmitter signal.

The transmitter transient frequency behaviour at switch-on and at switch-off, obtained as detailed above, shall be recorded. The test report shall include a graphical record of frequency difference versus time in each case.

10.11.3 Limits

During the periods t_1 and t_3 the frequency difference shall not exceed the value of 25 kHz.

During the period t_2 the frequency difference shall not exceed the value of 12,5 kHz.

After period t_2 and before period t_3 the frequency difference shall be within the limits of the transmitter frequency error, as defined in clause 10.2.3.

The limits of transient frequency behaviour are shown graphically in Figure 5.

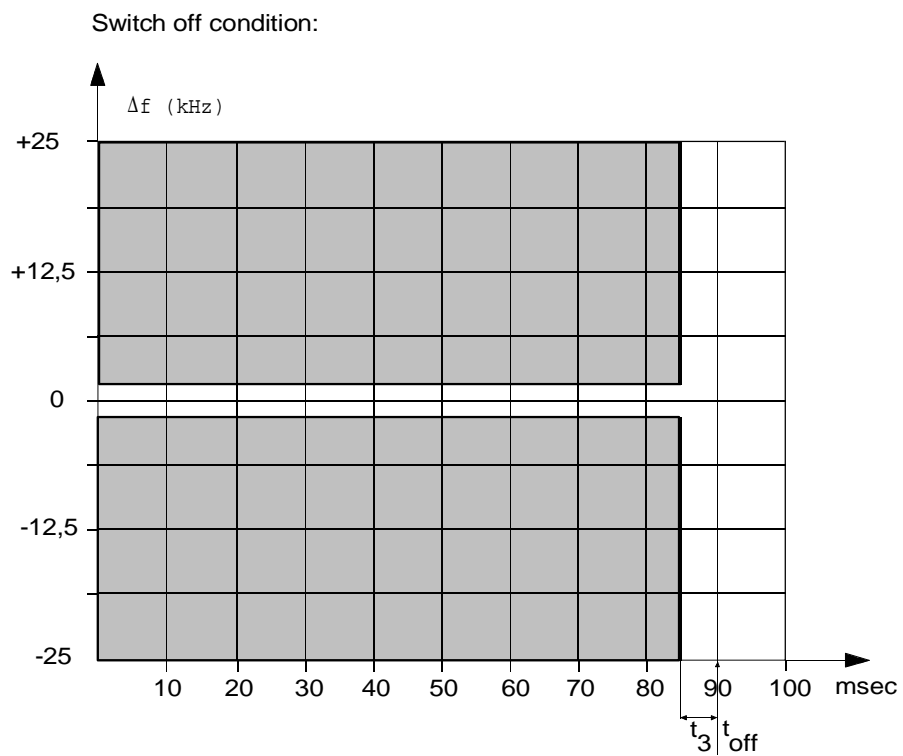
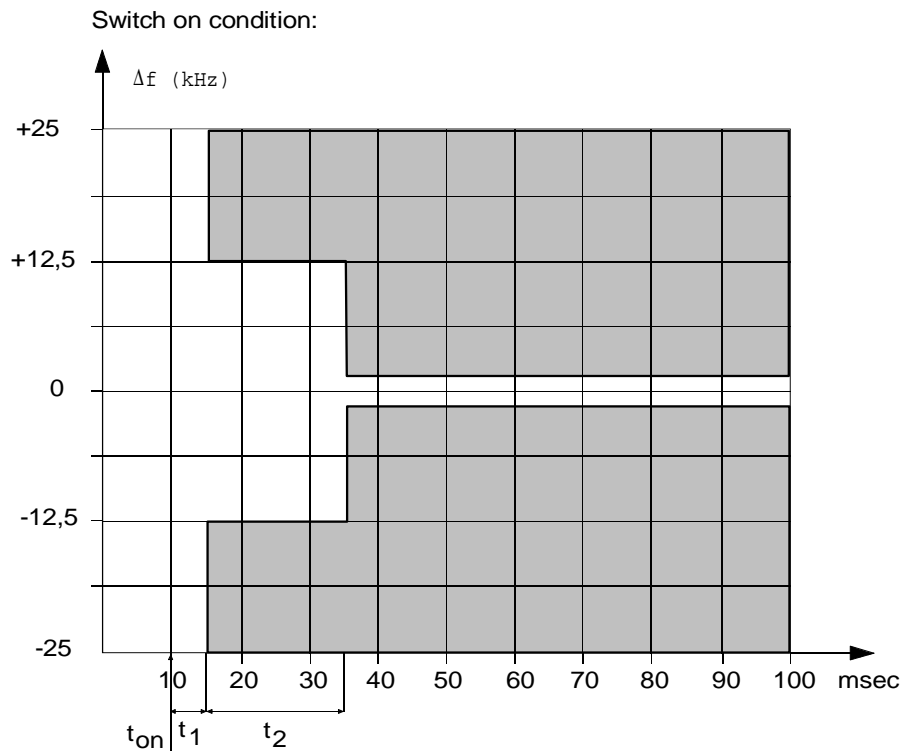

Figure 5: Transient frequency behaviour response masks

10.12 Radiated spurious emission

10.12.1 Definition

Spurious emissions are emissions on a frequency, or frequencies, which are outside the necessary bandwidth and the level of which may be reduced without affecting the corresponding transmission of information. Spurious emissions include harmonic emissions, parasitic emissions, intermodulation products and frequency conversion products but exclude out of band emissions.

10.12.2 Method of measurement

Measurements shall be made with the EUT in transmit mode.

On a test site, selected from clause 5 of ETSI TS 103 052 [12], the EUT shall be placed at the specified height on a non-conducting support and in the position closest to normal use as declared by the manufacturer.

The EUT antenna connector shall be connected to a non-reactive non-radiating 50 Ω termination.

The test antenna shall be orientated for vertical polarization.

The output of the test antenna shall be connected to a tuned radio measuring instrument or a spectrum analyser.

The EUT shall be switched on in transmit mode without modulation, and the measuring receiver shall be tuned over the frequency range 30 MHz to 2 GHz, except for the channel on which the transmitter is intended to operate and its adjacent channels.

The reference bandwidths for spurious emissions shall be in accordance with Recommendation ITU-R SM.329-12 [19], as follows:

- 1 kHz between 9 kHz and 150 kHz;
- 10 kHz between 150 kHz and 30 MHz;
- 100 kHz between 30 MHz and 1 GHz;
- 1 MHz above 1 GHz.

At each frequency at which a spurious component is detected:

- a) the test antenna shall be raised and lowered through the specified range of heights, and finally adjusted for the maximum signal level indication on the measuring receiver;
- b) the EUT shall then be rotated through 360° in the horizontal plane, and finally adjusted for the maximum signal level indication on the measuring receiver;
- c) the maximum signal level indication on the measuring receiver shall be noted;
- d) the transmitter shall be replaced by a calibrated substitution antenna as defined in clause 5.3.2 of ETSI TS 103 052 [12];
- e) the substitution antenna shall be orientated for vertical polarization and the length of the substitution antenna shall be adjusted to correspond to the frequency of the spurious component detected;
- f) the substitution antenna shall be connected to a calibrated signal generator;
- g) the frequency of the calibrated signal generator shall be set to the frequency of the spurious component detected;
- h) if necessary the input attenuator setting of the measuring receiver shall be adjusted in order to increase the sensitivity of the measuring receiver;
- i) the test antenna shall be raised and lowered through the specified range of heights to ensure that the maximum signal is received;

- j) the input signal to the substitution antenna shall be adjusted to produce a level, detected by the measuring receiver, equal to the level noted while the spurious component was measured (taking into account any change of input attenuator setting of the measuring receiver);
- k) the input power level to the substitution antenna, and any change of input attenuator setting of the measuring receiver, shall be recorded;
- l) the measurement shall be repeated with the test antenna and the substitution antenna orientated for horizontal polarization.

At each spurious emission frequency the measurement result is derived from the larger of the two power levels recorded, for horizontal and for vertical polarization, at the input to the substitution antenna. The measurement shall be corrected for the gain of the substitution antenna in dBd (gain relative to a tuned half-wave dipole), and for any change to the input attenuation of the measuring receiver between the EUT and the substitution phases of the measurement.

Measurements carried out with the transmitter operating in full power and repeated with reduced power.

10.12.3 Limits

The power of any radiated spurious emission on any discrete frequency shall not exceed the values given in Table 4.

Table 4: Power limits for radiated spurious emissions

Frequency Range	Mean power, in the reference bandwidth (see clause 7.13)
$30 \text{ MHz} \leq f \leq 2 \text{ GHz}$	-36 dBm
NOTE: f is the frequency of the spurious domain emission.	

11 Transmitter with DSC encoder

11.1 General

The transmitter shall be connected to a compatible DSC encoder device if an encoder is not integrated into the equipment.

The transmitter shall comply with the requirements from clauses 10.1 to 10.12.

The clauses below describe the additional test requirements for transmitters with a DSC encoder.

11.2 Frequency error (carrier)

11.2.1 Definition

The frequency error is the difference between the measured carrier frequency and its nominal value.

11.2.2 Method of measurement

The transmitter shall be connected to the artificial antenna as specified in clause 7.9.

The transmitter frequency shall be set to channel 70.

The measurement shall be performed without modulation.

The measurement shall be carried out under normal test conditions and extreme test conditions applied simultaneously.

If the carrier frequency during DSC operation is derived using same frequency reference as for telephony operation the measurement needs only to be carried out at normal temperature.

11.2.3 Limits

The frequency error shall be within $\pm 1,5$ kHz.

11.3 Frequency error (demodulated signal)

11.3.1 Definition

The frequency error for the B and the Y state is the difference between the measured frequency from the demodulator and the nominal values.

11.3.2 Method of measurement

The transmitter shall be connected to the artificial antenna as specified in clause 7.9.

The transmitter frequency shall be set to channel 70.

The equipment shall be set to transmit continuous B or Y state.

The measurement shall be carried out by measuring the demodulated output for both B and Y state.

The measurements shall be carried out under normal test conditions as defined in clause 6.3 and repeated under extreme test conditions as defined in clauses 6.4.1 and 6.4.2 applied simultaneously.

11.3.3 Limits

The measured frequency from the demodulator at any time for the B state shall be $1\ 300\ \text{Hz} \pm 10\ \text{Hz}$ and for the Y state $2\ 100\ \text{Hz} \pm 10\ \text{Hz}$.

11.4 Carrier Power

11.4.1 Definition

The carrier power is defined as the transmitter mean power delivered to the artificial antenna.

The rated output power is the carrier power declared by the manufacturer.

11.4.2 Method of measurement

The transmitter shall be connected to the artificial antenna as specified in clause 7.9.

The transmitter frequency shall be set to channel 70.

The power delivered to the artificial antenna shall be measured.

The measurements shall be carried out under normal test conditions as defined in clause 6.3 and repeated under extreme test conditions as defined in clauses 6.4.1 and 6.4.2 applied simultaneously.

If transmitter circuits used for DSC operation is the same as for telephony operation the measurement needs only to be carried out at normal temperature.

11.4.3 Limits

11.4.3.1 Normal test conditions

The carrier power shall remain between 6 W and 25 W and be within $\pm 1,5$ dB of the rated power.

11.4.3.2 Extreme test conditions

The carrier power shall remain between 6 W and 25 W and be within +2,0 dB and -3 dB of the rated power.

11.5 Modulation index

11.5.1 Definition

The modulation index of the modulated signal is determined as the ratio between the frequency deviation and the frequency of the modulation signal.

11.5.2 Method of measurement

The equipment shall be set to transmit continuous B and then Y state signal.

The transmitter output is connected to a linear FM demodulator. The frequency deviation is measured and the modulation index is calculated for both B and Y states.

11.5.3 Limits

The modulation index shall be $2,0 \pm 10 \%$.

11.6 Modulation rate

11.6.1 Definition

The modulation rate is the bit stream speed measured in bits/s.

11.6.2 Method of measurement

The equipment shall be set to transmit continuous dot pattern.

The transmitter output is connected to a linear FM demodulator and the frequency is measured.

11.6.3 Limits

The frequency shall be $600 \text{ Hz} \pm 30 \text{ ppm}$ corresponding to modulation rate of $1\,200 \text{ bit/s} \pm 30 \text{ ppm}$.

11.7 Residual modulation

11.7.1 Definition

The residual modulation of the transmitter is defined as the ratio in dB of the demodulated B or Y signal relative to the demodulated dot pattern.

11.7.2 Method of measurement

The transmitter output is connected to a linear FM demodulator with de-emphasis filter of first order. The filtered output is led on to the second linear FM demodulator. The output from the second demodulator is filtered out by second order low filter with cut off frequency of 3 kHz.

The rms level of the filtered output signal from the second demodulator is measured during transmission of continuous dot pattern and continuous B or Y state respectively.

The ratio of the two rms levels shall be determined.

11.7.3 Limits

The residual modulation shall be greater than -26 dB.

11.8 Modulator attack time

11.8.1 Definition

The modulator attack time is the time elapsed between keying the transmitter and the transmitter being correctly modulated.

11.8.2 Method of measurement

Arrangements for monitoring the transmitter output are shown in Figure 6. The transmitter output is coupled by suitable means to a wideband FM-demodulator, and the transmitter RF signal is used for external trigger to a storage oscilloscope connected to the output of the FM-demodulator. The oscilloscope is set for single trigger mode.

The test shall be performed on channel 70.

A DSC call (for guidance see annex C) shall be initiated and the measurement carried out.

The modulator attack time t_{att} is the elapsed time from when the RF carrier is present, until the demodulated 1 300 Hz/2 100 Hz audio tones are present.

11.8.3 Limit

The settling time t_{att} shall be less than 90 ms.

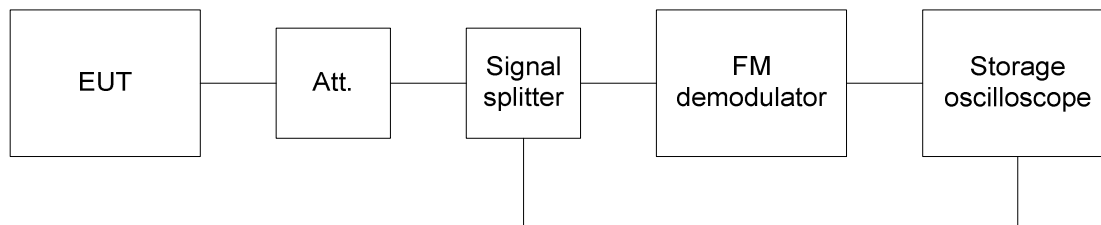

Figure 6: Modulator attack time test configuration

11.9 Adjacent channel power

11.9.1 Definition

The adjacent channel power is that part of the total power output of a transmitter modulated with continuous dot pattern, which falls within a specified passband centred on the nominal frequency of either of the adjacent channels.

11.9.2 Method of measurement

Measurements shall be made on channel 70.

The adjacent channel power shall be measured with a power measuring receiver which conforms to annex A, referred to in this clause and annex A as "the receiver":

- a) Arrangements for coupling the transmitter RF output to the "receiver" are specified in clause 7.9.

- b) With the transmitter unmodulated, the tuning of the "receiver" shall be adjusted so that a maximum response is obtained. This is the 0 dB response point. The "receiver" attenuator setting and the reading of the meter shall be recorded.
- c) The measurement may be made with the transmitter modulated with normal test modulation, in which case this fact shall be recorded with the test results.
- d) The tuning of the "receiver" shall be adjusted away from the carrier so that the "receiver" -6 dB response nearest to the transmitter carrier frequency is located at a displacement from the nominal carrier frequency of 17 kHz.
- e) The transmitter shall be modulated with continuous dot pattern and modulation index of 2,0.
- f) The "receiver" variable attenuator shall be adjusted to obtain the same meter reading as in step b) or a known relation to it.
- g) The ratio of adjacent channel power to carrier power is the difference between the attenuator settings in steps b) and f), corrected for any differences in the reading of the meter.
- h) The measurement shall be repeated with the "receiver" tuned to the other side of the carrier.

11.9.3 Limits

The adjacent channel power shall not exceed a value of 70 dB below the carrier power of the transmitter.

11.10 Conducted spurious emissions

The transmitter has to comply with the requirements listed in clause 10.9, but the measurements shall be carried out using channel 70.

11.11 Testing of free channel transmission on DSC channel 70

11.11.1 Definition

This test verifies that the transmitter has a facility to prevent transmission of DSC calls if channel 70 is busy, except in case of distress calls.

11.11.2 Method of measurement

The output of the transmitter shall be suitably connected to a calibrated apparatus for decoding and printing out the information content of the call sequences generated by the equipment.

The receiver input is connected to a signal generator. The signal generator is set to the frequency of channel 70 (156,525 MHz) and the RF signal shall be modulated by a standard DSC signal, see clause 7.11. The test is performed at an RF level; of +6 dB μ V (emf).

The signal generator shall be connected according to the arrangements defined in clause 7.4.

The signal generator output shall be turned on. The transmitter under test shall be set to transmit distress and non-distress DSC calls (for guidance on applicable calls see annex C).

Then the signal generator output shall be turned off.

11.11.3 Requirement

If the format specifier is distress in the transmitted DSC call, the call shall be transmitted while the signal generator output is still on.

Otherwise the call shall not be transmitted until the signal generator output has been turned off, and after a prioritized wait period defined in ETSI EN 300 338-2 [9].

11.12 Generated DSC call sequences

The output of the transmitter is connected to apparatus for decoding the information contents of the call sequences generated by the equipment.

The call sequences shall be validated in order to verify that the equipment is in accordance with Recommendation ITU-R 493-15 [5] and complies with all the requirements of ETSI EN 300 338-2 [9]. Annex C contains guidance on how to achieve compliance.

12 Receiver

12.1 Harmonic distortion and rated audio output power

12.1.1 Definition

Harmonic distortion at the receiver output, in the presence of a wanted RF signal modulated by an audio tone, is defined as the percentage ratio of the rms voltage of all the harmonics (of the audio tone fundamental frequency) within the recovered audio signal to its total rms voltage.

Rated audio output power is the maximum power available at the output as declared by the manufacturer, for which all the requirements of the present document are met.

12.1.2 Methods of measurement

A wanted test signal at +100 dB μ V emf shall be applied to the receiver RF input port as specified in clause 7.4. The receiver audio output shall be monitored as specified in clause 7.6.

Under normal test conditions as specified in clause 6.3 the test signal shall be modulated with an audio tone at 300 Hz, 500 Hz and 1 kHz successively, with a modulation index of 3 in each case.

The receiver volume control shall be set to obtain the rated audio output power and the harmonic distortion and audio output power shall be measured in each case.

Under extreme test conditions as specified in clause 6.4, the test signal shall be modulated with an audio tone at 1 kHz and with a modulation index of 3. The carrier frequency of the wanted test signal shall be set to the receiver's nominal frequency and to the nominal frequency $\pm 1,5$ kHz successively.

The receiver volume control shall be set to obtain the rated audio output power and the harmonic distortion and audio output power shall be measured in each case.

12.1.3 Limits

The rated audio output power shall be at least:

- 2 W in a loudspeaker;
- 1 mW in the handset earphone.

The harmonic distortion shall not exceed 10 %.

12.2 Audio frequency response

12.2.1 Definition

The audio frequency response is the variation in the receiver audio output level as a function of the modulating frequency of the radio frequency signal with constant deviation applied to its input.

12.2.2 Method of measurement

A wanted test signal at +60 dB μ V emf, modulated by the normal test modulation as specified in clause 7.5, shall be applied to the receiver RF input port as specified in clause 7.4. The receiver audio output shall be monitored as specified in clause 7.6.

The receiver volume control shall be set to produce at least 50 % of the rated audio output power. This setting shall remain unchanged during the test.

The test signal frequency deviation shall then be reduced to 1 kHz. The audio output level is the reference point in Figure 7 (i.e. 1 kHz frequency deviation corresponds to 0 dB).

The frequency of the modulating tone shall then be varied between 300 Hz and 3 kHz while the frequency deviation is maintained constant. The audio output level shall be measured over this range.

Measurements shall be made with the carrier frequency of the wanted test signal set to the receiver's nominal frequency and to the nominal frequency $\pm 1,5$ kHz successively.

12.2.3 Limits

The audio frequency response shall be within +1 dB and -3 dB of a 6 dB per octave line passing through the reference point, as shown in Figure 7.

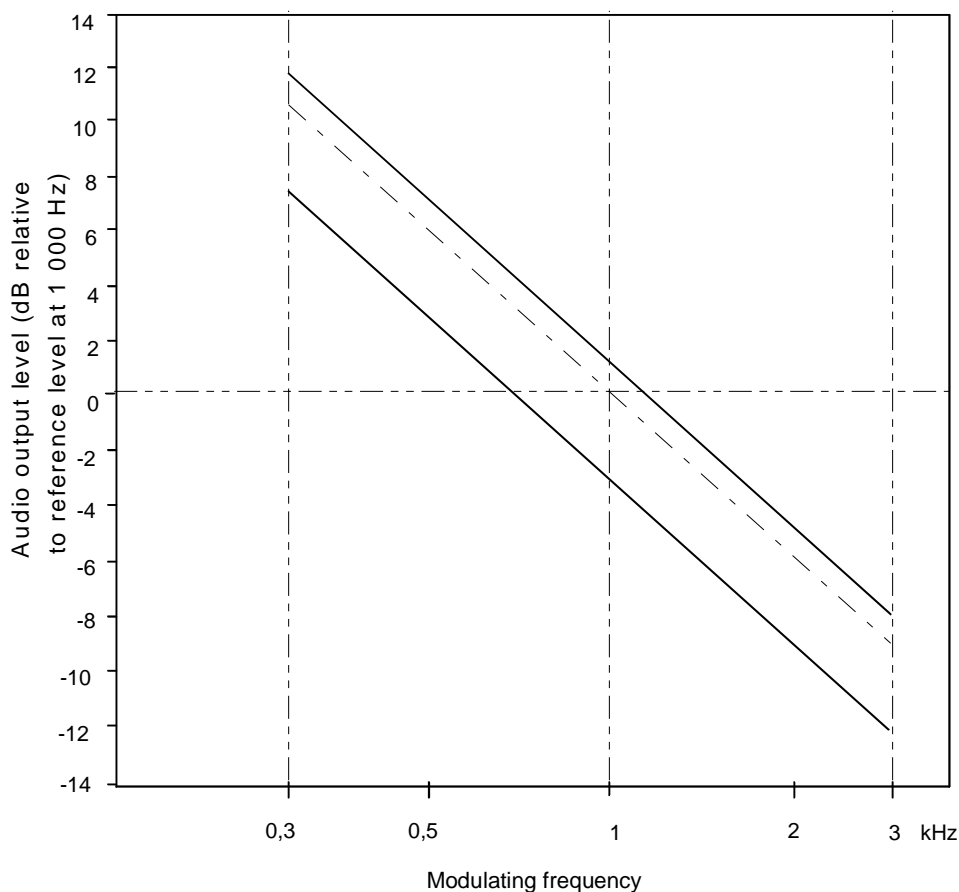

Figure 7: Receiver audio frequency response limits

12.3 Maximum usable sensitivity

12.3.1 Definition

The maximum usable sensitivity of the receiver is the minimum level of wanted RF signal, expressed in dB μ V emf, applied to the receiver input with normal test modulation, which will produce:

- a) an audio output power equal to 50 % of the rated audio output power; and
- b) a SINAD ratio of 20 dB, measured at the receiver output through a psophometric telephone filtering network such as described in Recommendation ITU-T O.41 [7].

12.3.2 Method of measurement

Measurements shall be made on channel 16, and also on the highest frequency and lowest frequency.

A test signal at a carrier frequency equal to the nominal frequency of the receiver, modulated by the normal test modulation as specified in clause 7.4 shall be applied to the receiver input. An audio frequency load and a measuring instrument for measuring the SINAD ratio through a psophometric network as specified in clause 7.6 shall be connected to the receiver output terminals.

The level of the test signal shall be adjusted until a SINAD ratio of 20 dB is obtained, using the psophometric network and with the receiver's volume control adjusted to produce 50 % of the rated output power. Under these conditions, the level of the test signal at the input is the value of the maximum usable sensitivity.

The measurements shall be made under normal test conditions as defined in clause 6.3 and under extreme test conditions as defined in clauses 6.4.1 and 6.4.2 applied simultaneously.

A receiver's audio output power variation of ± 3 dB relative to 50 % of the rated output power may be allowed for sensitivity measurements under extreme test conditions.

12.3.3 Limits

The maximum usable sensitivity for either 12,5 kHz or 25 kHz channels shall not exceed +6 dB μ V emf under normal test conditions and +12 dB μ V emf under extreme test conditions.

12.4 Amplitude characteristic of the receiver

12.4.1 Definition

The amplitude characteristic of the receiver is the relationship between the RF level of a specified modulated signal at the receiver input and the resulting audio level at the receiver output.

12.4.2 Method of measurement

A wanted test signal at +6 dB μ V emf, modulated by the normal test modulation as specified in clause 7.5, shall be applied to the receiver RF input port as specified in clause 7.4. The receiver audio output shall be monitored as specified in clause 7.6.

The receiver volume control shall be set to produce at least 50 % of the rated audio output power. The audio output level shall be recorded.

The level of the wanted test signal shall be increased to 100 dB μ V emf and the audio output level shall again be recorded. The amplitude characteristic of the receiver is characterized by the ratio between the two recorded audio output levels, expressed in dB.

12.4.3 Limits

For the specified change in RF input signal level, the change of audio output level shall not exceed 3,0 dB.

12.5 Co-channel rejection

12.5.1 Definition

Co-channel rejection is a measure of the capability of the receiver to receive a wanted modulated signal without exceeding a given degradation due to the presence of an unwanted modulated signal, both signals being at the nominal frequency of the receiver.

12.5.2 Method of measurement

The outputs from two signal generators, A and B, shall be combined and shall be applied to the receiver RF input port as specified in clause 7.4.

From signal generator A, a wanted test signal, modulated by the normal test modulation as specified in clause 7.5, shall be applied to the receiver RF input port at the maximum usable sensitivity level as measured in clause 12.3.

From signal generator B an unwanted signal, modulated by 400 Hz with a deviation of ± 3 kHz (see note), set to the nominal frequency of the receiver, shall be applied to the receiver RF input port at a low level.

The receiver audio output shall be monitored as specified in clause 7.6. The level of the unwanted signal shall be increased until the receiver output SINAD ratio falls to 14 dB.

The measurement shall be repeated for displacements of the unwanted signal over the range ± 3 kHz (see note).

The co-channel rejection ratio is the dB ratio of the level of the unwanted signal to the level of the wanted signal at the receiver input for which the specified degradation in SINAD ratio occurs.

NOTE: For 12,5 kHz channels the frequency deviation and the displacement of the unwanted signal should be $\pm 1,5$ kHz.

12.5.3 Limit

The co-channel rejection ratio, at any frequency of the unwanted signal within the specified range, shall be between:

- -10 dB and 0 dB for 25 kHz channels;
- -12 dB and 0 dB for 12,5 kHz channels.

12.6 Adjacent channel selectivity

12.6.1 Definition

Adjacent channel selectivity is a measure of the ability of the receiver to receive a wanted modulated signal without exceeding a given degradation due to the presence of an unwanted modulated signal which differs in frequency from the wanted signal by an amount equal to the adjacent channel separation.

12.6.2 Method of measurement

Measurements shall be made on channel 16, and also on the highest frequency and lowest frequency channels.

The outputs from two signal generators, A and B, shall be combined and shall be applied to the receiver RF input port as specified in clause 7.4.

From signal generator A, a wanted test signal, modulated by the normal test modulation as specified in clause 7.5, shall be applied to the receiver RF input port at the maximum usable sensitivity level as measured in clause 12.3.

From signal generator B, an unwanted signal, modulated by 400 Hz with a deviation of ± 3 kHz for 25 kHz channels or $\pm 1,5$ kHz for 12,5 kHz channels, set to the nominal frequency of the channel immediately above the test channel, shall be applied to the receiver RF input port at a low level.

The receiver audio output shall be monitored as specified in clause 7.6. The level of the unwanted signal shall be increased until the receiver output SINAD ratio falls to 14 dB.

The adjacent channel selectivity is the dB ratio of the level of the unwanted signal to the level of the wanted signal.

The measurement shall be repeated with an unwanted signal at the nominal frequency of the channel immediately below the test channel.

This test shall be carried out under normal test conditions and under extreme test conditions, as specified in clauses 6.3 and 6.4 respectively. Under extreme test conditions the wanted signal level shall be the maximum usable sensitivity level measured under extreme test conditions.

12.6.3 Limits

25 kHz channels: The adjacent channel selectivity shall be not less than 70 dB under normal test conditions and not less than 60 dB under extreme test conditions.

12,5 kHz channels: The adjacent channel selectivity shall be not less than 60 dB under normal test conditions and not less than 50 dB under extreme test conditions.

12.7 Spurious response rejection

12.7.1 Definition

Spurious response rejection is a measure of the ability of the receiver to discriminate between the wanted modulated signal at the nominal frequency and an unwanted signal at any other frequency at which a response is obtained.

12.7.2 Method of measurement

12.7.2.1 Introduction to the method of measurement

To determine the frequencies at which spurious responses can occur the following calculations shall be made:

- a) calculation of the "limited frequency range":
 - The "limited frequency range" is equal to:
 - the frequency of the local oscillator signal (f_{lo}) applied to the 1st mixer of the receiver \pm the sum of the intermediate frequencies (f_{IF1} , ... f_{IFn}) and a half the switching range (sr) of the receiver.
 - Hence:
 - the "limited frequency range" = $f_{lo} \pm (f_{IF1} + f_{IF2} + \dots + f_{IFn} + sr/2)$.
- b) calculation of frequencies outside the "limited frequency range":
 - A calculation of the frequencies at which spurious responses can occur outside the range determined in a) is made for the remainder of the frequency range of interest, as appropriate, clause 12.7.2.3.
 - The frequencies outside the "limited frequency range" are equal to:
 - the harmonics of the frequency of the local oscillator signal (f_{lo}) applied to the 1st mixer of the receiver \pm the numeric value of the 1st intermediate frequency (f_{IF1}) of the receiver.
 - Hence:
 - the frequencies of these spurious responses = $nf_{lo} \pm f_{IF1}$ where "n" is an integer greater than or equal to 2.

For the calculations a) and b) above the manufacturer shall state the frequency of the receiver, the frequency of the local oscillator signal (f_{lo}) applied to the 1st mixer of the receiver, the intermediate frequencies (f_{IF1} , f_{IF2} , etc.) and the switching range (sr) of the receiver.

12.7.2.2 Method of search over the "limited frequency range"

The two input signals shall be connected to the receiver via a combining network, clause 7.4.

The wanted test signal, at the nominal frequency of the receiver, with normal test modulation, clause 7.5, at the measured maximum useable sensitivity, shall be applied to the receiver input connector via one input of the combining network.

The unwanted test signal, modulated with a frequency of 400 Hz at a deviation of ± 5 kHz, at an emf of 86 dB μ V, shall be applied to the receiver input connector via the second input of the combining network.

The frequency of the unwanted signal shall be varied incrementally over the "limited frequency range".

The incremental steps of the frequency of the unwanted signal shall be 5 kHz.

The frequency of any spurious response detected during the search shall be recorded for the use in measurements in accordance with clause 12.7.2.3.

12.7.2.3 Method of measurement

The two input signals shall be connected to the receiver via a combining network, clause 7.4.

The wanted test signal, at the nominal frequency of the receiver, with normal test modulation, clause 7.5, at the measured maximum useable sensitivity shall be applied to the receiver input connector via one input of the combining network.

The unwanted test signal, modulated with a frequency of 400 Hz at a deviation of 60 % of the maximum permissible frequency deviation of 5 kHz, at an emf of 86 dB μ V, shall be applied to the receiver input connector via the second input of the combining network.

The measurement shall be performed at all spurious response frequencies found during the search over the "limited frequency range", clause 12.7.2.2, and at frequencies calculated for the remainder of the spurious response frequencies in the frequency range 100 kHz to 2 GHz.

At each frequency at which a spurious response occurs, the input level shall be adjusted until the SINAD ratio, psophometrically weighted, is reduced to 14 dB.

The measure of the spurious response rejection is the ratio in dB of the level of the unwanted test signal to the level of the wanted test signal at the receiver input for which the specified reduction in SINAD ratio occurs.

The ratio shall be recorded as the spurious response rejection for each spurious response obtained.

12.7.3 Limit

At any frequency separated from the nominal frequency of the receiver by more than 25 kHz, the spurious response rejection ratio shall be not less than 70 dB.

12.8 Intermodulation response

12.8.1 Definition

Intermodulation response is a measure of the ability of the receiver to receive a wanted modulated signal without exceeding a given degradation due to the presence of two or more unwanted signals with a specific frequency relationship to the wanted signal frequency.

12.8.2 Method of measurement

Three signal generators, A, B and C shall be connected to the receiver via a combining network as specified in clause 7.4. The wanted signal, represented by signal generator A shall be at the nominal frequency of the receiver and shall have normal test modulation as specified in clause 7.5. The unwanted signal from signal generator B shall be unmodulated and adjusted to the frequency 50 kHz above the nominal frequency of the receiver. The second unwanted signal from signal generator C shall be modulated by 400 Hz with a deviation of ± 3 kHz, and adjusted to a frequency 100 kHz above the nominal frequency of the receiver. Alternatively, the frequency of signal generator B and C may be 50 kHz and 100 kHz respectively, below the nominal frequency of the receiver.

The wanted input signal shall be set to a value corresponding to the maximum usable sensitivity as measured in clause 12.3. The amplitude of the two unwanted signals shall be maintained equal and shall be adjusted until the SINAD ratio at the receiver output, psophometrically weighted, is reduced to 14 dB. The frequency of signal generator B shall be adjusted slightly to produce the maximum degradation of the SINAD ratio. The level of the two unwanted test signals shall be readjusted to restore the SINAD ratio of 14 dB. The intermodulation response ratio shall be expressed as the ratio in dB between the two unwanted signals and the wanted signal at the receiver input, when the specified reduction in the SINAD ratio is obtained.

12.8.3 Limit

The intermodulation response ratio shall not be less than 70 dB.

12.9 Blocking or desensitization

12.9.1 Definition

Blocking is a change (generally a reduction) in the output power of the receiver or a reduction of the SINAD ratio due to a high level unwanted signal on another frequency.

12.9.2 Method of measurement

The outputs from two signal generators, A and B, shall be combined and shall be applied to the receiver RF input port as specified in clause 7.4.

From signal generator A, a wanted test signal, modulated by the normal test modulation as specified in clause 7.5, shall be applied to the receiver RF input port at the maximum usable sensitivity level as measured in clause 12.3.

The receiver volume control shall be set to produce at least 50 % of the rated audio output power.

Initially the unwanted signal shall be switched off.

From signal generator B, an unwanted signal shall be applied to the receiver RF input port at frequencies of ± 1 MHz, ± 2 MHz, ± 5 MHz, and ± 10 MHz relative to the nominal frequency of the receiver. The unwanted signal shall be unmodulated. The input level of the unwanted signal, at all the specified frequencies, shall be adjusted so as to cause:

- a) a reduction of 3 dB in the output level of the wanted audio signal; or
- b) a reduction of the SINAD ratio at the receiver output to 14 dB; whichever occurs first.

The blocking level in each case is the level of the unwanted signal as adjusted above.

12.9.3 Limit

The blocking level for any of the specified frequencies shall be not less than 90 dB μ V emf, except at frequencies on which spurious responses are found as specified in clause 12.7.

12.10 Conducted spurious emissions

12.10.1 Definition

Conducted spurious emissions from the receiver are all internally generated signals conducted to the antenna terminal of the receiver.

12.10.2 Method of measurement

The receiver shall be connected to the artificial antenna as described in clause 7.4.

The level of spurious emissions shall be measured as the power level of any discrete signal appearing at the receiver input.

The measurement shall be made in the range from 9 kHz to 2 GHz.

12.10.3 Limit

The power of the conducted spurious emissions on any discrete frequency shall not exceed the limits in Table 5.

Table 5: Power limits for conducted spurious emissions

Frequency Range	Mean power, in the reference bandwidth (see clause 7.13)
$9 \text{ kHz} \leq f \leq 1 \text{ GHz}$	-57 dBm
$1 \text{ GHz} < f \leq 2 \text{ GHz}$	-57 dBm
NOTE: f is the frequency of the spurious domain emission.	

12.11 Receiver noise and hum level

12.11.1 Definition

The receiver noise and hum level is defined as the dB ratio of the audio power of noise and hum resulting from spurious effects of the power supply system or from other causes, to the audio power produced from a wanted signal with normal test modulation applied to the receiver input.

12.11.2 Method of measurement

A wanted test signal at +30 dB μ V emf, modulated by the normal test modulation as specified in clause 7.5, shall be applied to the receiver RF input port as specified in clause 7.4. The receiver audio output shall be monitored as specified in clause 7.6.

The receiver volume control shall be set to produce the rated audio output power as declared by the manufacturer.

The total audio output power shall be measured. The modulation shall then be switched off and the output level measured again.

12.11.3 Limit

The receiver noise and hum level shall not exceed -40 dB, relative to the modulated signal.

12.12 Squelch operation

12.12.1 Description

The purpose of the squelch facility is to mute the receiver audio output in the absence of a valid RF signal at the receiver input. The squelch control may be on/off or continuously variable.

12.12.2 Squelch audio muting

12.12.2.1 Definition

The effectiveness of the muting of the receiver is characterized by measuring the receiver audio output in the absence of an input signal, relative to the rated audio output power as defined in clause 12.1.1.

12.12.2.2 Method of measurement

A wanted test signal at +30 dB μ V emf, modulated by the normal test modulation as specified in clause 7.5, shall be applied to the receiver RF input port as specified in clause 7.4. The receiver audio output shall be monitored as specified in clause 7.6.

The receiver volume control shall be set to produce at least 50 % of the rated audio output power. The wanted test signal shall then be suppressed, the squelch facility shall be switched on, and the receiver's total audio output power shall be measured.

12.12.2.3 Limits

The muted audio output power of the receiver shall not exceed -40 dB relative to the rated audio output power.

12.12.3 Squelch operating level

12.12.3.1 Definition

The squelch operating level is the minimum level of wanted signal presented to the receiver RF input port where the receiver audio output is always open.

12.12.3.2 Method of measurement

A wanted test signal at +6 dB μ V emf, modulated by the normal test modulation as specified in clause 7.5, shall be applied to the receiver RF input port as specified in clause 7.4. The receiver audio output shall be monitored as specified in clause 7.6. The receiver volume control shall be set to produce at least 50 % of the rated audio output power.

The wanted test signal shall then be reduced by 20 dB, and the squelch facility shall be switched on (in the case of a continuously variable squelch control this should be set to maximum) so that the receiver audio output is muted. The wanted test signal level shall then be gradually increased until the squelch opens and the receiver audio output is restored to 50 % of the rated audio output power.

12.12.3.3 Limits

The wanted test signal level required to restore the audio output shall not exceed +6 dB μ V emf. The SINAD ratio shall be not less than 20 dB.

12.12.4 Squelch hysteresis

12.12.4.1 Definition

Squelch hysteresis is the difference between the receiver input signal level at which the squelch opens and the level at which it closes, expressed in dB.

12.12.4.2 Method of measurement

A wanted test signal at $-14\text{ dB}\mu\text{V}$ emf, modulated by the normal test modulation as specified in clause 7.5, shall be applied to the receiver RF input port as specified in clause 7.4. The receiver audio output shall be monitored as specified in clause 7.6.

The squelch facility shall be switched on (in the case of a continuously variable squelch control this should be set to maximum) so that the receiver audio output is muted. The wanted test signal level shall then be gradually increased until the squelch opens. This level shall be recorded. The wanted test signal level shall then be gradually decreased until the squelch closes again and mutes the receiver audio output. This level shall also be recorded. The squelch hysteresis is the difference between the two recorded wanted test signal levels.

12.12.4.3 Limit

The squelch hysteresis shall be between 3 dB and 6 dB.

12.13 Multiple watch characteristics

12.13.1 Definitions

The scanning period is the time between the start of two successive samples of the priority channel in the absence of a signal on that channel.

The dwell time on the priority channel is the time between the start and finish of any sample of the priority channel in the absence of a signal on that channel.

The dwell time on the additional channel is the time between the start and finish of any sample of the additional channel.

12.13.2 Method of measurement

Scan facilities shall not be available on channel 70. The equipment shall be adjusted to scan the priority channel and one additional channel. The squelch shall be operational and so adjusted that the receiver just mutes on both channels.

The outputs from two signal generators, A and B, shall be combined and shall be applied to the receiver RF input port as specified in clause 7.4.

From signal generator A, a wanted test signal on the additional channel, modulated by the normal test modulation as specified in clause 7.5, shall be applied to the receiver RF input port at $+12\text{ dB}\mu\text{V}$ emf.

From signal generator B, a wanted test signal on the priority channel, unmodulated, shall be applied to the receiver RF input port at $+12\text{ dB}\mu\text{V}$ emf. Initially signal generator B output shall be switched off.

A storage oscilloscope shall be connected to the receiver audio output, set to trigger with the rise of signal generator B output on the priority channel. The scanning process shall be started and the output observed on the oscilloscope. The gap between the audio bursts and the duration of the audio bursts shall be measured. Signal generator B output on the priority channel shall then be switched on: the scanning shall stop on the priority channel at the next scan.

The measurement shall be performed with a simplex additional channel, and also with a duplex additional channel.

12.13.3 Limits

The scanning period shall not exceed 2 s.

The dwell time on the priority channel shall not exceed 150 ms.

The dwell time on the additional channel shall be between 850 ms and 2 s as indicated by the duration of the output bursts.

12.14 Radiated spurious emissions

12.14.1 Definition

Spurious emissions are emissions on a frequency, or frequencies, which are outside the necessary bandwidth and the level of which may be reduced without affecting the corresponding transmission of information. Spurious emissions include harmonic emissions, parasitic emissions, intermodulation products and frequency conversion products but exclude out of band emissions.

12.14.2 Method of measurement

Measurements shall be made with the EUT in receive mode.

On a test site, selected from clause 5 of ETSI TS 103 052 [12], the EUT shall be placed at the specified height on a non-conducting support and in the position closest to normal use as declared by the manufacturer.

The EUT antenna connector shall be connected to a non-reactive non-radiating 50 Ω termination.

The test antenna shall be orientated for vertical polarization.

The output of the test antenna shall be connected to a tuned radio measuring instrument or a spectrum analyser.

The measuring receiver shall be tuned over the frequency range 30 MHz to 2 GHz.

The reference bandwidths for spurious emissions shall be in accordance with Recommendation ITU-R SM.329-12 [19], as follows:

- 1 kHz between 9 kHz and 150 kHz;
- 10 kHz between 150 kHz and 30 MHz;
- 100 kHz between 30 MHz and 1 GHz;
- 1 MHz above 1 GHz.

At each frequency at which a spurious component is detected:

- a) the test antenna shall be raised and lowered through the specified range of heights, and finally adjusted for the maximum signal level indication on the measuring receiver;
- b) the EUT shall then be rotated through 360° in the horizontal plane, and finally adjusted for the maximum signal level indication on the measuring receiver;
- c) the maximum signal level indication on the measuring receiver shall be noted;
- d) the EUT shall be replaced by a calibrated substitution antenna as defined in clause 5.3.2 of ETSI TS 103 052 [12];
- e) the substitution antenna shall be orientated for vertical polarization and the length of the substitution antenna shall be adjusted to correspond to the frequency of the spurious component detected;
- f) the substitution antenna shall be connected to a calibrated signal generator;

- g) the frequency of the calibrated signal generator shall be set to the frequency of the spurious component detected;
- h) if necessary the input attenuator setting of the measuring receiver shall be adjusted in order to increase the sensitivity of the measuring receiver;
- i) the test antenna shall be raised and lowered through the specified range of heights to ensure that the maximum signal is received;
- j) the input signal to the substitution antenna shall be adjusted to produce a level, detected by the measuring receiver, equal to the level noted while the spurious component was measured (taking into account any change of input attenuator setting of the measuring receiver);
- k) the input power level to the substitution antenna, and any change of input attenuator setting of the measuring receiver, shall be recorded;
- l) the measurement shall be repeated with the test antenna and the substitution antenna orientated for horizontal polarization.

At each spurious emission frequency the measurement result is derived from the larger of the two power levels recorded, for horizontal and for vertical polarization, at the input to the substitution antenna. The measurement shall be corrected for the gain of the substitution antenna in dBd (gain relative to a tuned half-wave dipole), and for any change to the input attenuation of the measuring receiver between the EUT and the substitution phases of the measurement.

12.14.3 Limits

The power of any radiated spurious emission on any discrete frequency shall not exceed the values given in Table 6.

Table 6: Power limits for radiated spurious emissions

Frequency Range	Test Limits	Field Strength Equivalent (informative)
30 MHz to 156 MHz	-57 dBm	41 dB μ V/m (quasi-peak)
156 MHz to 165 MHz	-74 dBm	24 dB μ V/m (quasi-peak)
165 MHz to 1 GHz	-57 dBm	41 dB μ V/m (quasi-peak)
1 GHz to 2 GHz	-47 dBm	51 dB μ V/m (quasi-peak)

13 Receiver with a DSC decoder

The receiver shall be connected to a compatible DSC decoder device if a decoder is not integrated into the equipment.

DSC requirements for signalling on channel 70 shall comply with to ETSI EN 301 033 [17].

For equipment supporting DSC signalling on channels different from channel 70 (semi-/automatic PSTN calling as defined in Recommendation ITU-R M.689-2 [i.10]) the main receiver shall comply with the calling sensitivity requirements from ETSI EN 301 033 [17] on at least one working channel.

14 Duplex operation

14.1 Introduction

If the equipment is designed for duplex operation, when submitted for conformance testing it shall be fitted with a duplex filter and the following additional measurements shall be carried out to ensure satisfactory duplex operation.

14.2 Receiver desensitization with simultaneous transmission and reception

14.2.1 Definition

The desensitization is the degradation of the sensitivity of the receiver resulting from the transfer of power from the transmitter to the receiver due to coupling effects.

It is expressed as the difference in dB of the maximum usable sensitivity levels with simultaneous transmission and without.

14.2.2 Method of measurement

The antenna terminal of the equipment comprising the receiver, transmitter and duplex filter shall be connected to appropriate test equipment as specified in clauses 7.4 and 7.9.

A signal generator with normal test modulation (see clause 7.5) shall be connected via a coupling device so that it does not affect the impedance matching.

The transmitter shall be brought into operation with the output power set at maximum, modulated by 400 Hz with a deviation of ± 3 kHz:

- the receiver sensitivity shall then be measured in accordance with clause 12.3;
- the output level of the signal generator shall be recorded as C in dB μ V emf;
- the transmitter shall be switched off and the receiver sensitivity is again measured;
- the output level of the signal generator shall be recorded as D in dB μ V emf;
- the desensitization is the difference between the values of C and D.

14.2.3 Limits

The desensitization shall not exceed 3 dB. The maximum usable sensitivity under conditions of simultaneous transmission and reception shall not exceed the limits specified in clause 12.3.

14.3 Duplex transceiver internal mixing

14.3.1 Definition

The duplex transceiver internal mixing is an unwanted receiver response at certain frequencies when the transmitter is active.

14.3.2 Method of measurement

The antenna terminal of the equipment comprising the receiver, transmitter and duplex filter shall be connected to appropriate test equipment as specified in clauses 7.4 and 7.9.

A test port enabling signal to be converted to the receiver shall be provided.

The equipment shall be tuned to channel 18 and the transmitter be brought into unmodulated operation with the output power set at maximum.

The test defined in clause 12.7 using the test port as the receiver port shall be performed. Notwithstanding the frequency mentioned in clause 12.7, the test shall only be performed in the following bands:

- $\{ 161,5 - (2 \times f_{IF}) - 1 \}$ MHz to $\{ 161,5 - (2 \times f_{IF}) + 1 \}$ MHz

- $\{161,5 + (2 \times f_{IF}) - 1\}$ MHz to $\{161,5 + (2 \times f_{IF}) + 1\}$ MHz
- $\{156,9 + f_{IF} - 1\}$ MHz to $\{156,9 + f_{IF} + 1\}$ MHz
- $\{156,9 - f_{IF} - 1\}$ MHz to $\{156,9 - f_{IF} + 1\}$ MHz
- $\{156,9 - 4,6 - 1\}$ MHz to $\{156,9 + 4,6 + 1\}$ MHz

where f_{IF} is the first intermediate frequency of the receiver, to be stated by the manufacturer.

14.3.3 Limits

At any frequency at which a response is detected, the ratio defined in clause 12.7 shall be not less than 70 dB.

Annex A (normative): Measuring receiver for adjacent channel power measurement

A.1 General description of power measuring receiver

The power measuring receiver consists of a mixer, an IF filter, and oscillator, an amplifier, a variable attenuator and an rms value indicator. Instead of the variable attenuator with the rms value indicator it is also possible to use an rms voltmeter calibrated in dB. The technical characteristics of the power measuring receiver are given below. See also Recommendation ITU-R SM.332-4 [i.9].

A.2 IF filter

The IF filter shall be within the limits of the following selectivity characteristic.

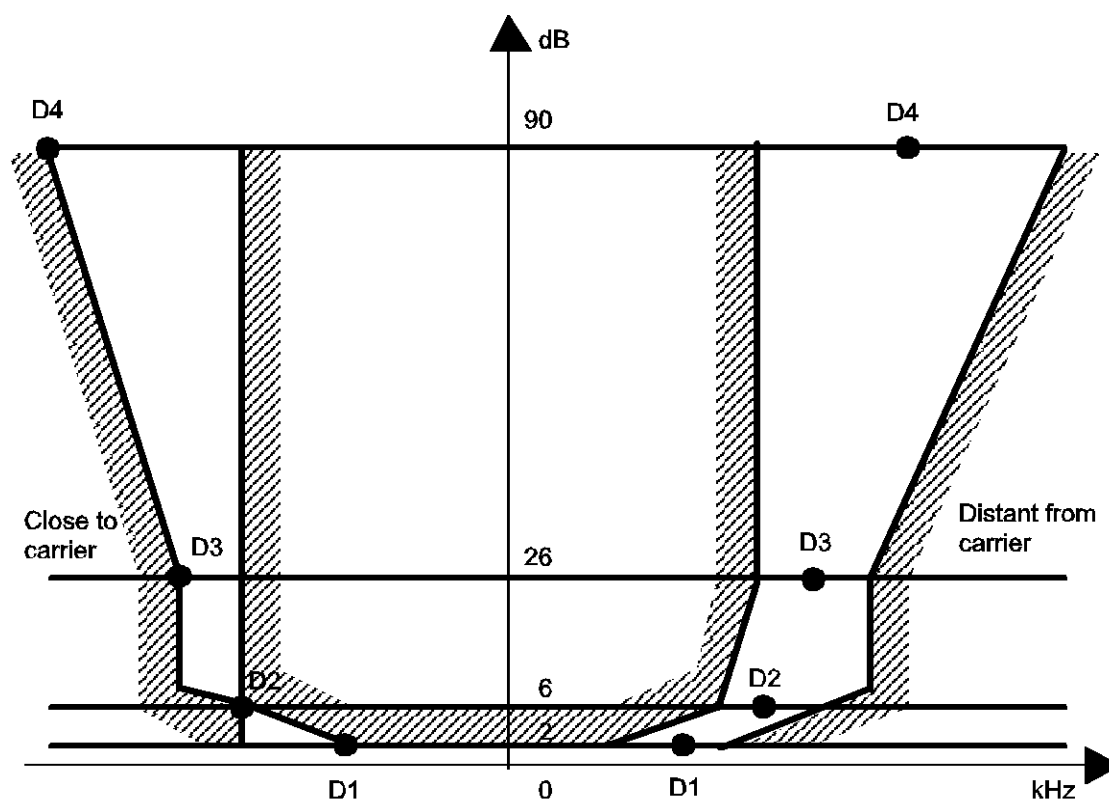

Figure A.1: IF Filter selectivity characteristic

Table A.1: Selectivity characteristic

Channel separation (kHz)	Frequency separation of filter curve from nominal centre frequency of adjacent channel (kHz)			
	D1	D2	D3	D4
12,5	3	4,25	5,5	9,5
25	5	8,0	9,25	13,25

The attenuation points shall not exceed following tolerances shown in Table A.2.

Table A.2: Tolerance of attenuation points close to carrier

Channel separation (kHz)	Tolerance range (kHz)			
	D1	D2	D3	D4
12,5	+1,35	$\pm 0,1$	-1,35	-5,35
25	+3,1	$\pm 0,1$	-1,35	-5,35

Table A.3: Tolerance of attenuation points distant from the carrier

Channel separation (kHz)	Tolerance range (kHz)			
	D1	D2	D3	D4
12,5	$\pm 2,0$	$\pm 2,0$	$\pm 2,0$	+2,0 -6,0
25	$\pm 3,5$	$\pm 3,5$	$\pm 3,5$	+3,5 -7,5

The minimum attenuation of the filter outside the 90 dB attenuation points shall be equal to or greater than 90 dB.

A.3 Attenuation indicator

The attenuation indicator shall have a minimum range of 80 dB and a reading accuracy of 1 dB. With a view to future regulations the attenuation should be 90 dB or more.

A.4 RMS value indicator

The instrument shall accurately indicate non-sinusoidal signals in a ratio of up to 10:1 between peak value and rms value.

A.5 Oscillator and amplifier

The oscillator and the amplifier shall be designed in such a way that the measurement of the adjacent channel power of a low-noise unmodulated transmitter, whose self-noise has a negligible influence on the measurement result, yields a measured value of < -90 dB.

Annex B (normative): Protocol for the IEC 61162-1 commands Frequency Set Information (FSI)

B.1 Frequency Set Information (FSI)

This sentence is used to set frequency, mode of operation and transmitter power level of a radiotelephone, to read out frequencies, mode and power and to acknowledge setting commands. Details are shown in Figure B.1.

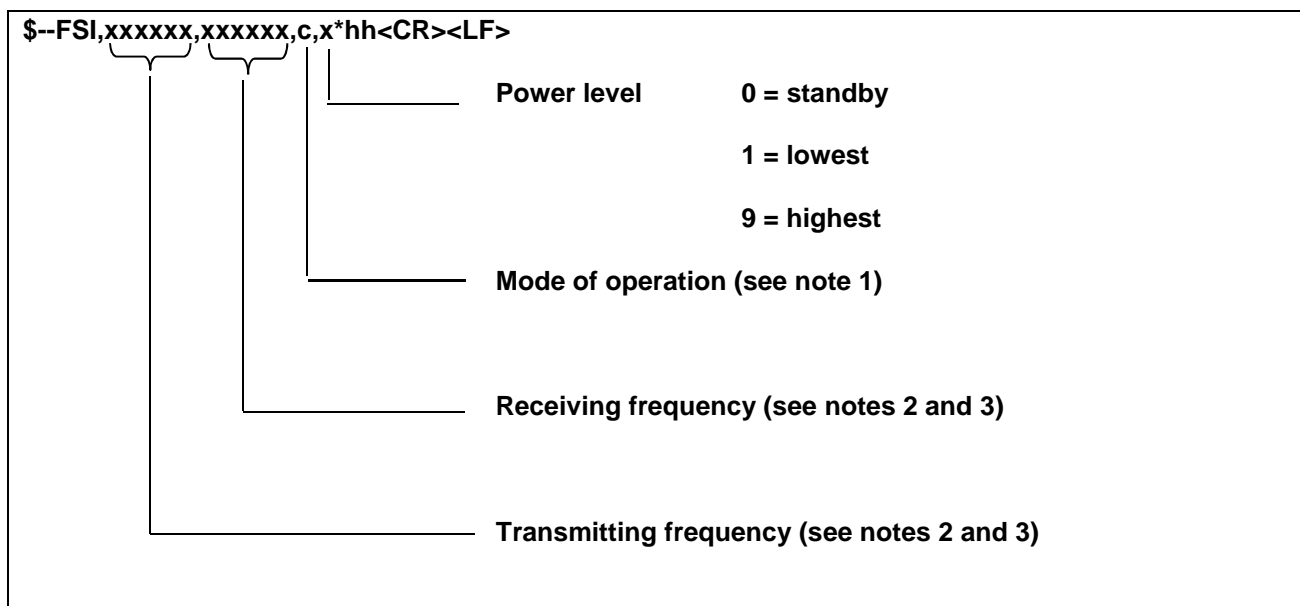

NOTE 1: Mode of operation:

- d = F3E/G3E simplex, telephone;
- e = F3E/G3E duplex, telephone;
- m = J3E, telephone;
- o = H3E, telephone;
- q = F1B/J2B FEC NBDP, TELEX/teleprinter;
- s = F1B/J2B ARQ NBDP, TELEX/teleprinter;
- t = F1B/J2B receive only, teleprinter/DSC;
- w = F1B/J2B, teleprinter/DSC;
- x = A1A Morse, tape recorder;
- { = A1A Morse, morse key/head set;
- | = F1C/F2C/F3C, FAX-machine;
- null for no information.

NOTE 2: Frequencies to be in 100 Hz increments:

- MF/HF telephone channels to have first digit 3, followed by ITU channel numbers with leading zeros as required;
- MF/HF teletype channels to have first digit 4; the second and third digit give the frequency bands, and the fourth to sixth digits ITU channel numbers; each with leading zeros as required;
- VHF channels to have first digit 9 followed by zero. The next number is "1" indicating the ship station's transmit frequency is being used as a simplex channel frequency, or "2" indicating the coast station's transmit frequency is being used as a simplex channel frequency, "0" otherwise. The remaining three numbers are the VHF channel numbers with leading zeros as required.

NOTE 3: For paired frequencies, the transmitting frequency only needs to be included; null for receiving frequency field. For receive frequencies only, the transmitting frequency field shall be null.

Figure B.1: Frequency set information

Annex C (informative): DSC test calls

C.1 Interoperability tests

The validation of the DSC functionality (VHF class A) may be performed using the interoperability tests defined in ETSI TS 101 570-2 [i.5].

History

Document history		
V1.1.1	September 2002	Publication
V1.2.1	December 2006	Publication
V1.3.1	September 2010	Publication
V1.4.1	May 2013	Publication
V1.5.1	October 2017	Publication
V1.5.2	March 2020	EN Approval Procedure AP 20200628: 2020-03-30 to 2020-06-29
V1.6.0	October 2020	Vote V 20201208: 2020-10-09 to 2020-12-08
V1.6.1	December 2020	Publication