

Draft **ETSI EN 301 925** V1.1.1 (2001-08)

---

*European Standard (Telecommunications series)*

**Electromagnetic compatibility  
and Radio spectrum Matters (ERM);  
Radiotelephone transmitters and receivers for the  
maritime mobile service operating in VHF bands;  
Technical characteristics and methods of measurement**

---



---

**Reference**

DEN/ERM-RP01-024

---

**Keywords**

EMC, GMDSS, maritime, radio, telephony, VHF

**ETSI**

---

650 Route des Lucioles  
F-06921 Sophia Antipolis Cedex - FRANCE

Tel.: +33 4 92 94 42 00 Fax: +33 4 93 65 47 16

Siret N° 348 623 562 00017 - NAF 742 C  
Association à but non lucratif enregistrée à la  
Sous-Préfecture de Grasse (06) N° 7803/88

---

**Important notice**

Individual copies of the present document can be downloaded from:

<http://www.etsi.org>

The present document may be made available in more than one electronic version or in print. In any case of existing or perceived difference in contents between such versions, the reference version is the Portable Document Format (PDF). In case of dispute, the reference shall be the printing on ETSI printers of the PDF version kept on a specific network drive within ETSI Secretariat.

Users of the present document should be aware that the document may be subject to revision or change of status. Information on the current status of this and other ETSI documents is available at <http://www.etsi.org/tb/status/>

If you find errors in the present document, send your comment to:  
[editor@etsi.fr](mailto:editor@etsi.fr)

---

**Copyright Notification**

No part may be reproduced except as authorized by written permission.  
The copyright and the foregoing restriction extend to reproduction in all media.

© European Telecommunications Standards Institute 2001.  
All rights reserved.

# Contents

Intellectual Property Rights .....	9
Foreword.....	9
1 Scope.....	10
2 References .....	10
3 Definitions, symbols and abbreviations .....	12
3.1 Definitions .....	12
3.2 Symbols .....	13
3.3 Abbreviations.....	13
4 General requirements .....	14
4.1 Construction.....	14
4.2 Controls and indicators.....	14
4.3 Handset and loudspeaker .....	15
4.4 Safety precautions .....	15
4.5 Labelling.....	16
4.6 Warm up .....	16
5 Technical requirements .....	16
5.1 Switching time .....	16
5.2 Class of emission and modulation characteristics .....	16
5.3 Multiple watch facilities .....	16
5.3.1 Additional performance standards .....	16
5.3.2 Scanning characteristics .....	17
5.4 DSC controller interfaces.....	17
5.4.1 Interface requirements.....	17
5.4.2 Signal interfaces.....	17
5.4.3 Operational interfaces .....	17
5.5 Voyage data recorder interface .....	18
6 Test conditions, power sources and ambient temperatures .....	18
6.1 Test conditions.....	18
6.2 Test power source.....	18
6.3 Normal test conditions.....	18
6.3.1 Normal temperature and humidity .....	18
6.3.2 Normal power source voltage .....	18
6.3.2.1 Mains powered equipment .....	18
6.3.2.2 Battery powered equipment .....	18
6.3.2.3 Other power sources .....	19
6.4 Extreme test conditions.....	19
6.4.1 Extreme temperatures.....	19
6.4.2 Extreme values of power source voltage .....	19
6.4.2.1 Mains powered equipment .....	19
6.4.2.2 Battery powered equipment .....	19
6.4.2.3 Other power sources .....	19
6.5 Procedure for tests at extreme temperatures.....	19
7 General conditions of measurement .....	19
7.1 Sequence of testing.....	19
7.2 Test channels.....	20
7.3 Squelch .....	20
7.4 Arrangements for test signals applied to the receiver input .....	20
7.5 Normal test modulation of the receiver wanted signal.....	20
7.6 Arrangements for monitoring the receiver output .....	20
7.7 Arrangements for test signals applied to the transmitter input .....	20
7.8 Normal test modulation of the transmitter .....	21
7.9 Arrangements for monitoring the transmitter output .....	21

7.10	DSC encoder/decoder .....	21
7.11	Standard test signals for DSC .....	21
7.12	Determination of symbol error ratio in the output of the receiver .....	21
7.13	Interpretation of the measurement results .....	21
8	Performance checks .....	22
8.1	Performance checks - introduction .....	22
8.2	Performance check - transmitter frequency error .....	22
8.3	Performance check - transmitter carrier power .....	22
8.4	Performance check - transmitter audio frequency harmonic distortion of the emission .....	23
8.5	Performance check - receiver sensitivity .....	23
9	Environmental tests .....	23
9.1	Procedure .....	23
9.2	Vibration test .....	23
9.2.1	Definition .....	23
9.2.2	Method of measurement .....	23
9.2.3	Requirement .....	24
9.3	Temperature tests .....	24
9.3.1	Introduction .....	24
9.3.2	General Procedure .....	24
9.3.3	Dry heat .....	24
9.3.3.1	Definition .....	24
9.3.3.2	Method of measurement .....	24
9.3.3.3	Requirement .....	24
9.3.4	Damp heat .....	25
9.3.4.1	Definition .....	25
9.3.4.2	Method of measurement .....	25
9.3.4.3	Requirement .....	25
9.3.5	Low temperature cycle .....	25
9.3.5.1	Definition .....	25
9.3.5.2	Method of measurement .....	25
9.3.5.3	Requirement .....	25
10	Emissions tests .....	26
10.1	General conditions for emissions tests .....	26
10.2	Conducted emissions from power ports .....	26
10.2.1	Definition .....	26
10.2.2	Test method .....	26
10.2.3	Limits .....	27
10.3	Radiated emissions from the enclosure port .....	27
11	Immunity tests .....	28
11.1	General conditions for immunity tests .....	28
11.1.1	Introduction .....	28
11.1.2	Performance assessment .....	28
11.1.3	Ancillary equipment .....	28
11.1.4	Test configuration .....	28
11.1.5	Arrangements for test signals .....	29
11.1.5.1	General arrangements .....	29
11.1.5.2	Arrangements for test signals applied to the transmitter input .....	29
11.1.5.3	Arrangements for monitoring the transmitter output .....	29
11.1.5.4	Arrangements for test signals applied to the receiver input .....	29
11.1.5.5	Arrangements for monitoring the receiver output .....	29
11.1.6	Exclusion bands .....	30
11.1.6.1	Definition .....	30
11.1.6.2	Transmitter exclusion band for immunity tests .....	30
11.1.6.3	Receiver exclusion band for immunity tests .....	30
11.1.7	Assessment of receiver responses .....	30
11.2	Performance criteria .....	30
11.2.1	Categories .....	30
11.2.2	Performance criteria A for continuous phenomena .....	31
11.2.3	Performance criteria B for transient phenomena .....	31

11.2.4	Performance criteria C for power supply failure.....	31
11.2.5	Immunity performance check .....	31
11.3	Electrostatic discharge immunity (ESD).....	31
11.3.1	Definition .....	31
11.3.2	Test method.....	32
11.3.3	Performance criteria.....	32
11.4	RF electromagnetic fields in the frequency range 80 MHz to 2 GHz.....	32
11.4.1	Definition .....	32
11.4.2	Test method.....	32
11.4.3	Performance criteria.....	33
11.5	Fast transient, common mode .....	33
11.5.1	Definition .....	33
11.5.2	Test method.....	33
11.5.3	Performance criteria.....	33
11.6	Conducted disturbances on power ports (RF common mode).....	33
11.6.1	Definition .....	33
11.6.2	Test method.....	34
11.6.3	Performance criteria.....	35
11.7	Power supply short term variations .....	35
11.7.1	Definition .....	35
11.7.2	Test method.....	35
11.7.3	Performance criteria.....	35
11.8	Power supply failure.....	35
11.8.1	Definition .....	35
11.8.2	Test method.....	36
11.8.3	Performance criteria.....	36
11.9	Surge .....	36
11.9.1	Definition .....	36
11.9.2	Test method.....	36
11.9.3	Performance criteria.....	36
12	Cabinet radiation and antenna port spurious emissions .....	37
12.1	Conducted spurious emissions conveyed to the antenna.....	37
12.1.1	Definition .....	37
12.1.2	Method of measurement.....	37
12.1.3	Limit .....	37
12.2	Cabinet radiation .....	38
12.2.1	Definition .....	38
12.2.2	Method of measurement.....	38
12.2.3	Limits.....	39
13	Transmitter .....	39
13.1	General conditions.....	39
13.2	Frequency error.....	39
13.2.1	Definition .....	39
13.2.2	Method of measurement.....	39
13.2.3	Limits.....	40
13.3	Carrier power .....	40
13.3.1	Definitions.....	40
13.3.2	Method of measurement.....	40
13.3.3	Limits.....	40
13.3.3.1	General.....	40
13.3.3.2	Normal test conditions .....	40
13.3.3.3	Extreme test conditions.....	40
13.4	Frequency deviation .....	40
13.4.1	Definition .....	40
13.4.2	Maximum permissible frequency deviation.....	41
13.4.2.1	Method of measurement.....	41
13.4.2.2	Limits.....	41
13.4.3	Reduction of frequency deviation at modulation frequencies above 3 kHz.....	41
13.4.3.1	Method of measurement.....	41
13.4.3.2	Limits.....	41

13.5	Sensitivity of the modulator including the microphone .....	42
13.5.1	Definition .....	42
13.5.2	Method of measurement.....	42
13.5.3	Limits.....	42
13.6	Audio frequency response.....	42
13.6.1	Definition .....	42
13.6.2	Method of measurement.....	42
13.6.3	Limits.....	43
13.7	Audio frequency harmonic distortion of the emission.....	43
13.7.1	Definition .....	43
13.7.2	Method of measurement.....	43
13.7.3	Limits.....	44
13.8	Adjacent channel power .....	44
13.8.1	Definition .....	44
13.8.2	Method of measurement.....	44
13.8.3	Limits.....	44
13.9	Residual modulation of the transmitter.....	44
13.9.1	Definition .....	44
13.9.2	Method of measurement.....	45
13.9.3	Limit .....	45
13.10	Modulator attack time.....	45
13.10.1	Definition .....	45
13.10.2	Method of measurement.....	45
13.10.3	Limit .....	45
13.11	Transient frequency behaviour of the transmitter.....	46
13.11.1	Definition .....	46
13.11.2	Method of measurement.....	46
13.11.3	Limits.....	48
13.12	DSC audio input characteristics .....	50
13.12.1	Definition .....	50
13.12.2	Method of measurement.....	50
13.12.3	Limits.....	50
13.13	DSC audio input limitation .....	50
13.13.1	Definition .....	50
13.13.2	Method of measurement.....	50
13.13.3	Limit .....	50
13.14	Testing of generated DSC call sequences .....	50
13.14.1	Definition .....	50
13.14.2	Method of measurement.....	51
13.14.3	Requirement .....	51
14	Receiver .....	51
14.1	Harmonic distortion and rated audio output power .....	51
14.1.1	Definition .....	51
14.1.2	Methods of measurement .....	51
14.1.3	Limits.....	52
14.2	Audio frequency response.....	52
14.2.1	Definition .....	52
14.2.2	Method of measurement.....	52
14.2.3	Limits.....	52
14.3	Maximum usable sensitivity .....	53
14.3.1	Definition .....	53
14.3.2	Method of measurement.....	53
14.3.3	Limits.....	54
14.4	Amplitude characteristic of the receiver .....	54
14.4.1	Definition .....	54
14.4.2	Method of measurement.....	54
14.4.3	Limits.....	54
14.5	Co-channel rejection.....	54
14.5.1	Definition .....	54
14.5.2	Method of measurement.....	54
14.5.3	Limit .....	55

14.6	Adjacent channel selectivity .....	55
14.6.1	Definition .....	55
14.6.2	Method of measurement.....	55
14.6.3	Limits.....	55
14.7	Spurious response rejection .....	55
14.7.1	Definition .....	55
14.7.2	Method of measurement.....	56
14.7.2.1	Introduction to the method of measurement.....	56
14.7.2.2	Method of search over the "limited frequency range".....	56
14.7.2.3	Method of measurement.....	57
14.7.3	Limit .....	57
14.8	Intermodulation response.....	57
14.8.1	Definition .....	57
14.8.2	Method of measurement.....	57
14.8.3	Limit .....	57
14.9	Blocking or desensitisation .....	58
14.9.1	Definition .....	58
14.9.2	Method of measurement.....	58
14.9.3	Limit .....	58
14.10	Receiver noise and hum level .....	58
14.10.1	Definition .....	58
14.10.2	Method of measurement.....	58
14.10.3	Limit .....	58
14.11	Squelch operation.....	59
14.11.1	Description .....	59
14.11.2	Squelch audio muting.....	59
14.11.2.1	Definition .....	59
14.11.2.2	Method of measurement.....	59
14.11.2.3	Limits.....	59
14.11.3	Squelch operating level .....	59
14.11.3.1	Definition .....	59
14.11.3.2	Method of measurement.....	59
14.11.3.3	Limits.....	59
14.11.4	Squelch hysteresis.....	60
14.11.4.1	Definition .....	60
14.11.4.2	Method of measurement.....	60
14.11.4.3	Limit .....	60
14.12	Multiple watch characteristics.....	60
14.12.1	Definitions.....	60
14.12.2	Method of measurement.....	60
14.12.3	Limits.....	61
14.13	DSC audio output characteristic.....	61
14.13.1	Definition .....	61
14.13.2	Methods of measurement .....	61
14.13.3	Limit .....	61
14.14	DSC maximum usable sensitivity .....	61
14.14.1	Definition .....	61
14.14.2	Method of measurement.....	61
14.14.3	Limits.....	61
14.15	DSC co-channel rejection .....	62
14.15.1	Definition .....	62
14.15.2	Method of measurement.....	62
14.15.3	Limits.....	62
14.16	DSC Adjacent channel selectivity.....	62
14.16.1	Definition .....	62
14.16.2	Method of measurement.....	62
14.16.3	Limits.....	62
14.17	DSC dynamic range.....	63
14.17.1	Definition .....	63
14.17.2	Method of measurement.....	63
14.17.3	Limit .....	63
14.18	DSC intermodulation response.....	63

14.18.1	Definition .....	63
14.18.2	Method of measurement.....	63
14.18.3	Limits.....	63
14.19	Verification of correct decoding of various types of DSC calls .....	63
14.19.1	Definition .....	63
14.19.2	Method of measurement.....	64
14.19.3	Requirement .....	64
15	Duplex operation .....	64
15.1	Introduction.....	64
15.2	Receiver desensitisation with simultaneous transmission and reception .....	64
15.2.1	Definition .....	64
15.2.2	Method of measurement.....	64
15.2.3	Limits.....	65
15.3	Duplex transceiver internal mixing .....	65
15.3.1	Definition .....	65
15.3.2	Method of measurement.....	65
15.3.3	Limits.....	65
<b>Annex A (normative): Measuring receiver for adjacent channel power measurement.....</b>		<b>66</b>
A.1	General description of power measuring receiver .....	66
A.2	IF filter .....	66
A.3	Attenuation indicator .....	67
A.4	RMS value indicator .....	67
A.5	Oscillator and amplifier .....	67
<b>Annex B (normative): Protocol for the EN 61162-1 commands Frequency Set Information (FSI) .....</b>		<b>68</b>
B.1	Frequency Set Information (FSI).....	68
<b>Annex C (normative): Radiated measurements.....</b>		<b>69</b>
C.1	Test sites and general arrangements for measurements involving the use of radiated fields .....	69
C.1.1	Outdoor test site .....	69
C.1.2	Test antenna .....	70
C.1.3	Substitution antenna .....	70
C.1.4	Optional additional indoor site.....	70
C.2	Guidance on the use of radiation test sites .....	71
C.2.1	Measuring distance.....	71
C.2.2	Test antenna.....	71
C.2.3	Substitution antenna .....	71
C.2.4	Artificial antenna.....	72
C.2.5	Auxiliary cables .....	72
C.2.6	Acoustic measuring arrangement .....	72
C.3	Further optional alternative indoor test site using an anechoic chamber .....	72
C.3.1	Example of the construction of a shielded anechoic chamber.....	73
C.3.2	Influence of parasitic reflections in anechoic chambers .....	73
C.3.3	Calibration of the shielded anechoic chamber.....	74
History	.....	76



---

## Intellectual Property Rights

IPRs essential or potentially essential to the present document may have been declared to ETSI. The information pertaining to these essential IPRs, if any, is publicly available for **ETSI members and non-members**, and can be found in ETSI SR 000 314: "*Intellectual Property Rights (IPRs); Essential, or potentially Essential, IPRs notified to ETSI in respect of ETSI standards*", which is available from the ETSI Secretariat. Latest updates are available on the ETSI Web server (<http://www.etsi.org/ipr>).

Pursuant to the ETSI IPR Policy, no investigation, including IPR searches, has been carried out by ETSI. No guarantee can be given as to the existence of other IPRs not referenced in ETSI SR 000 314 (or the updates on the ETSI Web server) which are, or may be, or may become, essential to the present document.

---

## Foreword

This European Standard (Telecommunications series) has been produced by ETSI Technical Committee Electromagnetic compatibility and Radio spectrum Matters (ERM), and is now submitted for the Public Enquiry phase of the ETSI standards Two-step Approval Procedure.

<b>Proposed national transposition dates</b>	
Date of latest announcement of this EN (doa):	3 months after ETSI publication
Date of latest publication of new National Standard or endorsement of this EN (dop/e):	6 months after doa
Date of withdrawal of any conflicting National Standard (dow):	6 months after doa

---

# 1 Scope

The present document specifies the minimum requirements for shipborne radio transmitters and receivers for fixed installations operating in the VHF frequency bands between 156 MHz and 174 MHz allocated to the maritime mobile service, capable of Radiotelephony and Digital Selective Calling communications within the Global Maritime Distress and Safety System. The present document incorporates the requirements of the relevant resolutions of the International Maritime Organisation (IMO) and is primarily intended to specify equipment suitable for fitting to ships subject to the SOLAS Convention [1] and complying with the European Marine Equipment Directive [2].

The EMC parameters defined in the clauses of the present document covering emission tests and immunity test (see clauses 10 and 11) have been selected to ensure an adequate level of compatibility for apparatus in marine environments.

Compliance to the EMC requirements of the present document does not signify compliance to any safety requirements. However, it is the responsibility of the assessor of the equipment to record in their test report any observations regarding the test sample becoming dangerous or unsafe as a result of the application of the tests called for herein.

The present document does not address the testing of ancillary equipment on a stand-alone basis, i.e. separately from the radio equipment with which it is to be used.

---

# 2 References

The following documents contain provisions which, through reference in this text, constitute provisions of the present document.

- References are either specific (identified by date of publication and/or edition number or version number) or non-specific.
- For a specific reference, subsequent revisions do not apply.
- For a non-specific reference, the latest version applies.

- [1] IMO SOLAS 1974 International Convention for the Safety of Life at Sea (Consolidated Edition 2001 incorporating all amendments in effect on 1 January 2001).
- [2] Council Directive 96/98/EC of 20 December 1996 on marine equipment (as amended by Commission Directive 98/85/EC) (the European Marine Equipment Directive).
- [3] IMO Resolution A.803(19) (as amended by MSC.68(68)): "Performance standards for shipborne VHF radio installations capable of voice communication and digital selective calling".
- [4] IMO Resolution A.524(13): "Performance standards for VHF multiple watch facilities".
- [5] ITU Radio Regulations (1998).
- [6] ITU Radio Regulations Appendix S18 (1998): "Table of transmitting frequencies in the VHF maritime mobile band".
- [7] ITU-R Recommendation M.489-2 (1995): "Technical characteristics of VHF radiotelephone equipment operating in the maritime mobile service in channels spaced by 25 kHz".
- [8] ITU-R Recommendation M.493-10 (2000): "Digital selective-calling system for use in the maritime mobile service".
- [9] ITU-R Recommendation M.541-8 (1997): "Operational procedures for the use of digital selective-calling equipment in the maritime mobile service".
- [10] ITU-R Recommendation SM.329-8 (2000): "Spurious emissions".
- [11] ITU-R Recommendation SM.332-4 (1978): "Selectivity of receivers".

- [12] ITU-T Recommendation E.161 (1995): "Arrangement of digits, letters and symbols on telephones and other devices that can be used for gaining access to a telephone network".
- [13] ITU-T Recommendation O.41 (1994): "Psophometer for use on telephone-type circuits".
- [14] CISPR 16-1 (1999): "Specification for radio disturbance and immunity measuring apparatus and methods - Part 1: Radio disturbance and immunity measuring apparatus".
- [15] ETSI ETR 028 Ed.2: "Radio Equipment and Systems (RES); Uncertainties in the measurement of mobile radio equipment characteristics".
- [16] ETSI EN 300 338 (V1.2.1): "Electromagnetic compatibility and Radio spectrum Matters (ERM); Technical characteristics and methods of measurement for equipment for generation, transmission and reception of Digital Selective Calling (DSC) in the maritime MF, MF/HF and/or VHF mobile service".
- [17] EN 60945 (2001): "Maritime navigation and radiocommunication equipment and systems - General requirements - Methods of testing and required test results".
- [18] IEC 61000-4-2 (Ed.1.2) (2001): "Electromagnetic compatibility (EMC) - Part 4-2: Testing and measurement techniques - Electrostatic discharge immunity test".
- [19] IEC 61000-4-3 (Ed.1.2) (2001): "Electromagnetic compatibility (EMC) - Part 4-3: Testing and measurement techniques - Radiated, radio-frequency, electromagnetic field immunity test".
- [20] EN 61000-4-4 (1995) amended by Am1 (2001): "Electromagnetic compatibility (EMC) - Part 4-4: Testing and measurement techniques - Electrical fast transient/burst immunity test".
- [21] IEC 61000-4-5 (Ed.1.1) (2001): "Electromagnetic compatibility (EMC) - Part 4-5: Testing and measurement techniques - Surge immunity test".
- [22] IEC 61000-4-6 (Ed.1.1) (2001): "Electromagnetic compatibility (EMC) - Part 4-6: Testing and measurement techniques - Immunity to conducted disturbances, induced by radio-frequency fields".
- [23] IEC 61000-4-11 (Ed.1.1) (2001): "Electromagnetic compatibility (EMC) - Part 4-11: Testing and measuring techniques - Voltage dips, short interruptions and voltage variations immunity tests".
- [24] EN 61162-1 (2000): "Maritime navigation and radiocommunication equipment and systems - Digital interfaces - Part 1: Single talker and multiple listeners".
- [25] IEC 60050-161 (1990): "International Electrotechnical Vocabulary. Chapter 161: Electromagnetic compatibility".

---

## 3 Definitions, symbols and abbreviations

### 3.1 Definitions

For the purposes of the present document, the following terms and definitions apply:

**ancillary equipment:** equipment (apparatus) used in connection with a transmitter or receiver is considered to be an ancillary equipment if:

- the equipment is intended for use in conjunction with a transmitter or receiver to provide additional operational or control features to the radio equipment (e.g. to extend control to another position or location); and
- the equipment cannot be used on a stand alone basis to provide user functions independently of the radio equipment; and
- the radio equipment to which it is connected is capable of providing some intended operation, such as transmitting or receiving, without the ancillary equipment (i.e. it is not a sub-unit of the radio equipment essential to the basic functions of the radio equipment).

**continuous phenomena (continuous disturbance):** electromagnetic disturbance, the effects of which on a particular device or equipment cannot be resolved into a succession of distinct effects (see IEC 60050-161)

**duplex operation:** operating method in which transmission is possible simultaneously in both directions of a telecommunications channel

**effective radiated power:** product of the power supplied to the antenna and its gain relative to a half-wave dipole (see ITU Radio Regulations)

**enclosure port:** physical boundary of the apparatus through which electromagnetic fields may radiate or impinge

NOTE 1: In the case of integral antenna equipment, this port is inseparable from the antenna port.

**G3E:** phase-modulation (frequency modulation with a pre-emphasis of 6 dB/octave) for speech operation

**G2B:** phase-modulation (frequency modulation with a pre-emphasis of 6 dB/octave) for Digital Selective Calling (DSC) operation

NOTE 2: The carrier is modulated by a sub-carrier which is FSK modulated by digital data.

**integral antenna:** antenna designed to be connected directly to the equipment with or without the use of an external connector and considered to be part of the equipment

NOTE 3: An integral antenna may be fitted internally or externally to the equipment.

**mobile equipment:** marine receiver, transmitter or transmitter/receiver (transceiver) intended for installation and use onboard ships, and powered by the ship's supply

**modulation index:** ratio between the frequency deviation and the frequency of the modulating audio signal

**operating frequency range:** range(s) of continuous radio frequencies covered by the Equipment Under Test without any change of units

**performance check:** check of the transmitter frequency error, carrier power, audio frequency harmonic distortion of emission (see clauses 8.2, 8.3 and 8.4); and receiver sensitivity (see clause 8.5) of EN 301 925

**port:** particular interface of the specified equipment (apparatus), with the electromagnetic environment

NOTE 4: For example, any connection point on an equipment intended for connection of cables to or from that equipment is considered as a port (see figure 1).

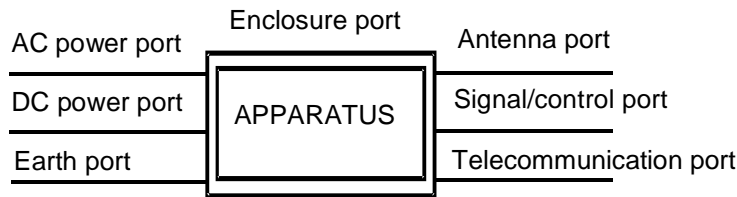

**Figure 1: EUT Ports for EMC purposes**

**Q ratio:** ratio of an observed magnitude of acceleration at the equipment to the magnitude of acceleration at the base of the vibration table

**radio communications equipment:** marine communications equipment which includes one or more radio transmitters or receivers or parts thereof, for use in a mobile application onboard ship

NOTE 5: Such equipment may be operated with ancillary equipment but, if so, is not dependent upon it for basic functionality.

**semi-duplex operation:** operating method in which simplex operation is used at one end of the circuit and duplex operation at the other

**simplex:** operating method in which transmission is made possible alternately in each direction of a telecommunications channel, for example, by means of manual control

**spurious emission:** emission on a frequency, or frequencies, which are outside the necessary bandwidth and the level of which may be reduced without affecting the corresponding transmission of information

NOTE 6: Spurious emissions include harmonic emissions, parasitic emissions, intermodulation products and frequency conversion products but exclude out-of-band emissions (see ITU Radio Regulations [5]).

**switching range:** maximum frequency range over which the receiver or the transmitter can be operated without reprogramming or realignment

**transient phenomena:** pertaining to or designating a phenomena or a quantity which varies between two consecutive steady states during a time interval short compared with the time-scale of interest (see IEC 60050-161)

## 3.2 Symbols

For the purposes of the present document, the following symbols apply:

dBa	sound pressure relative to $2 \times 10^{-5}$ Pa
dBd	antenna gain relative to a half-wave dipole
Q	mechanical resonance

## 3.3 Abbreviations

For the purposes of the present document, the following abbreviations apply:

AC	Alternating Current
DC	Direct Current
DSC	Digital Selective Calling
EMC	ElectroMagnetic Compatibility
emf	electromotive force
ESD	Electrostatic Discharge
EUT	Equipment Under Test
$f_{lo}$	frequency of the local oscillator signal

FSI	Frequency Set Information
GMDSS	Global Maritime Distress and Safety System
$f_{IF}$	Intermediate Frequency
pd	potential difference
RF	Radio Frequency
rms	root mean square
SINAD	Signal + Noise + Distortion/Noise + Distortion
sr	switching range
VDR	Voyage Data Recorder
VHF	Very High Frequency

## 4 General requirements

### 4.1 Construction

The manufacturer shall declare compliance to the requirements of clause 4 and shall provide relevant documentation.

The mechanical and electrical construction and finish of the equipment shall conform in all respects to good engineering practice, and the equipment shall be suitable for use on board ships.

All controls shall be of sufficient size to enable the usual control functions to be easily performed and the number of controls should be the minimum necessary for simple and satisfactory operation.

All parts of the equipment to be checked during inspection or maintenance operations shall be readily accessible. The components shall be readily identifiable.

Technical documentation shall be supplied with the equipment.

The equipment, which may consist of more than one unit, shall be capable of operating on single frequency (simplex) and two-frequency (semi-duplex) channels with manual control. When operating on two-frequency channels there shall be a separation of 4,6 MHz between the transmitting frequency and the receiving frequency (see Radio Regulations Appendix S18 [6]). The equipment may also be capable of operating on two-frequency channels without manual control (duplex).

The equipment shall be able to operate on all channels listed in Appendix S18 to the Radio Regulations [6] except AIS1 and AIS2. Additional channels may also be provided, but means shall exist to block any or all of these additional channels, as may be required by an Administration, before installation onboard ship. It shall not be possible for the user to block or unblock channels.

Use of channel 70 for purposes other than DSC shall be prevented (see ITU-R Recommendation M.493-10 [8] and ITU-R Recommendation M.541-8 [9]).

It shall not be possible to transmit while any frequency synthesizer used within the transmitter is out of lock.

It shall not be possible to transmit during channel switching operations.

### 4.2 Controls and indicators

The equipment shall have a channel selector and shall indicate the designator of the selected channel, as shown in Appendix S18 to the Radio Regulations [6]. The channel designator shall be legible irrespective of external lighting conditions.

Channel 16 shall be distinctively marked. Selection of channel 16 shall be by readily accessible means (e.g. a distinctively marked key allowing channel 16 to be selected by a single operator action). There shall be a distinctive indication when channel 70 is selected automatically for DSC operation.

Where an input panel on the equipment for entering the digits 0 to 9 is provided, this shall conform to ITU-T Recommendation E.161 [12].

The equipment shall have the following additional controls and indicators (see IMO Resolution A.803(19) [3]):

- a) on/off switch for the entire installation with a visual indication that the installation is in operation;
- b) manual non-locking press-to-talk switch to activate the transmitter;
- c) visual indication that the transmitter is activated;
- d) switch for reducing transmitter output power to no more than 1 W;
- e) on/off switch for the loudspeaker, if a telephone handset is also provided;
- f) audio volume control;
- g) squelch control;
- h) brightness control for reducing the equipment illumination to zero except that those warning and alarm indicators which are illuminated in the warning/alarm condition and indicators required for switching on/off or resetting the equipment or for the initiation of distress alerting shall be clearly visible in all appropriate conditions of ambient illumination.

The equipment shall also meet the following requirements:

- i) the user shall not have access to any control which, if wrongly set, might impair the technical characteristics of the equipment;
- j) if the equipment may be controlled from two or more control consoles, then one of the consoles shall have priority over the others. The operation of one console shall be indicated on all other consoles.

## 4.3 Handset and loudspeaker

The equipment shall be fitted with a telephone handset or microphone, and an integral loudspeaker or a socket for an external loudspeaker. A handset is required if duplex operation is provided.

It shall be possible to switch off the loudspeaker without causing a variation in the volume provided to the handset.

In simplex operation the receiver output shall be muted during transmission. In duplex operation only the handset shall be operative, to ensure correct operation and to prevent harmful electrical or acoustic feedback which might produce oscillations.

## 4.4 Safety precautions

The equipment shall be protected against the effects of overcurrent and overvoltage.

The equipment shall be protected against damage due to accidental reversal of polarity of the power supply.

Means shall be provided for earthing exposed metallic parts of the equipment, but this shall not cause any terminal of the source of electrical energy to be earthed.

All components and wiring in which the DC or AC voltage (other than radio-frequency voltage), produce, singly or in combination, peak voltages in excess of 50 V, shall be protected against any accidental access and shall be automatically isolated from all electrical power sources if the protective covers are removed. Alternatively, the equipment shall be constructed in such a way as to prevent access to components operating at such voltages unless an appropriate tool such as a nut-spanner or screwdriver is used. Conspicuous warning labels shall be affixed both inside the equipment and on the protective covers.

No damage to the equipment shall occur when the antenna port is terminated with an open circuit or a short circuit for a period of at least five minutes in each case.

In order to provide protection against damage due to build up of static charge at the antenna terminals, there shall be a DC path from the antenna terminals to chassis not exceeding 100 k $\Omega$ .

The information in any volatile memory device shall be protected from 3 consecutive interruptions in the power supply of up to 60 s duration as described in IEC 61000-4-11 [23].

## 4.5 Labelling

All controls, instruments, indicators and terminals shall be clearly labelled (see IMO Resolution A.803(19) [3]).

Details of the power supply which the equipment is intended to operate from shall be clearly indicated on the equipment.

All units of the equipment shall be clearly marked on the exterior with the identification of the manufacturer, the type designation of the equipment, and the serial number of the unit.

The compass safe distance shall be clearly marked on the equipment or stated in the user documentation supplied with the equipment.

## 4.6 Warm up

After being switched on the equipment shall be operational within 5 s.

---

# 5 Technical requirements

## 5.1 Switching time

The channel switching arrangement shall be such that the time necessary to change over from using one channel to using any other channel does not exceed 5 s.

The time necessary to change over from transmission to reception or vice versa, shall not exceed 0,3 s.

## 5.2 Class of emission and modulation characteristics

The equipment shall use phase modulation, G3E (frequency modulation with a pre-emphasis of 6 dB per octave) for speech (see ITU-R Recommendation M.489-2 [7]) and G2B for DSC signalling.

The equipment shall be designed to operate satisfactorily with a channel separation of 25 kHz.

## 5.3 Multiple watch facilities

### 5.3.1 Additional performance standards

VHF radiotelephone equipment having multiple watch facilities shall comply with the following additional performance standards (see IMO Resolution A.524(13) [4]):

- a) the equipment may include provision for the automatic scanning of a priority channel and one additional channel. If this facility is included then it shall meet the following requirements. Facilities for the automatic sequential change of the additional channel may be provided, which are not accessible to the user. Means shall be provided to enable/disable this facility;
- b) the priority channel is that channel which will be sampled even if there is a signal on the additional channel and on which the receiver will lock during the time a signal is detected;
- c) the additional channel is that channel which will be monitored during the periods the equipment is not sampling or receiving signals on the priority channel;
- d) provision shall be included to switch the scanning facility on and off by means of a manually operated control. In addition it shall be ensured that the receiver remains on the same channel as the transmitter for the entire duration of any communication with the ship, e.g. the scanning facility could be switched off automatically when the handset is off its hook;



- e) selection of the additional channel and selection of the priority channel shall be possible at the operating position;
- f) when the scanning facility is in operation, the channel number of both channels on which the equipment is operating shall be clearly indicated simultaneously;
- g) in a transceiver, transmission shall not be possible when the scanning facility is operating. When the scanning facility is switched off, both transmitter and receiver shall be tuned automatically to the selected additional channel;
- h) a transceiver shall be provided with a single manual control (e.g. push-button) in order to switch the equipment quickly for operation on the priority channel;
- i) at the operating position of a transceiver the selected additional channel shall be clearly indicated as being the operational channel of the equipment.

### 5.3.2 Scanning characteristics

When the scanning facility is switched on, the priority channel shall be sampled with a sampling period of not more than 2 s. If a signal is detected on the priority channel the receiver shall remain on this channel for the duration of that signal.

If a signal is detected on the additional channel the sampling of the priority channel shall continue, thus interrupting the reception on the channel for periods as short as possible and not greater than 150 ms.

The design of the receiver shall provide for its proper functioning during the period the priority channel is sampled since the receiving conditions on the priority channel may differ from those on the additional channel.

In the absence of a signal on the priority channel, and, during reception of a signal on the additional channel, the duration of each listening period on this channel shall be at least 850 ms.

Means shall be provided to indicate the channel on which a signal is being received.

## 5.4 DSC controller interfaces

### 5.4.1 Interface requirements

The equipment under test shall be capable of DSC operation. To facilitate this, it shall contain either:

- an internal DSC controller compliant with EN 300 338 [16] for generation, transmission, reception and display of DSC; or
- the two interfaces detailed in clauses 5.4.2 and 5.4.3.

### 5.4.2 Signal interfaces

To facilitate the connection of separate DSC controller equipment, transmitter equipment shall have a DSC signal input port, and receiver equipment shall have a DSC signal output port, both with a characteristic impedance of 600  $\Omega$ , symmetrical and free of earth.

### 5.4.3 Operational interfaces

The interface for control shall comply with EN 61162-1 [24].

The protocols shall at least comply with Frequency Set Information (FSI) (see annex B).

Transmitter key input interface shall be a 2-wire circuit closure to transmit with a maximum open circuit voltage of 50 V and a maximum closed circuit current of 100 mA.

Connectors used should be readily available commercially. Manufacturers shall provide identification of the actual connections used.

## 5.5 Voyage data recorder interface

To facilitate the connection of separate VDR equipment, a single audio output port shall be provided, with a characteristic impedance of 600  $\Omega$ , symmetrical and free of earth, on which combined transmit and receive audio shall be present.

---

# 6 Test conditions, power sources and ambient temperatures

## 6.1 Test conditions

Tests shall be carried out under normal test conditions and also, where stated, under extreme test conditions.

Tests under normal test conditions shall be carried out using the normal power source voltage as defined in clause 6.3.2 under conditions of normal temperature and humidity as defined in clause 6.3.1.

Tests under extreme test conditions shall be carried out using extreme values of power source voltage as defined in clause 6.4.2 at the extremes of temperature defined in clause 6.4.1.

## 6.2 Test power source

During testing, the equipment shall be supplied from a test power source capable of producing the necessary supply voltages.

The internal impedance of the test power source shall be low enough for its effect on the test results to be negligible. The power source voltage shall be measured at the input terminals of the equipment, and during testing this voltage shall be maintained within a tolerance of  $\pm 3$  % relative to the voltage level at the beginning of each test.

## 6.3 Normal test conditions

### 6.3.1 Normal temperature and humidity

The normal temperature and humidity conditions for test shall be any combination of temperature and humidity within the following ranges:

- temperature: +15°C to +35°C;
- relative humidity: 20 % to 75 %.

The test conditions shall be recorded in the test report.

### 6.3.2 Normal power source voltage

#### 6.3.2.1 Mains powered equipment

The normal power source voltage for equipment intended to be connected to the AC mains shall be any one of the nominal mains voltages with which the equipment is declared by the manufacturer to be compatible. The power source frequency shall be the nominal frequency with which the equipment is declared by the manufacturer to be compatible.

#### 6.3.2.2 Battery powered equipment

Where equipment is intended to operate from a battery, the normal power source voltage shall be the nominal voltage of the battery as declared by the manufacturer.

### 6.3.2.3 Other power sources

For operation from other power sources the normal power source voltage shall be that declared by the manufacturer.

## 6.4 Extreme test conditions

### 6.4.1 Extreme temperatures

For tests at extreme temperatures measurements shall be made, in accordance with clause 6.5, at a lower temperature of  $-15^{\circ}\text{C}$  and at an upper temperature of  $+55^{\circ}\text{C}$ .

### 6.4.2 Extreme values of power source voltage

#### 6.4.2.1 Mains powered equipment

The extreme values of power source voltage and frequency for equipment intended to be connected to the AC mains shall be the nominal mains voltage  $\pm 10\%$  and the nominal power source frequency  $\pm 1\text{ Hz}$ .

#### 6.4.2.2 Battery powered equipment

Where equipment is intended to operate from a battery, the upper and lower extreme values of power source voltage shall be 1,3 times and 0,9 times the nominal voltage of the battery as declared by the manufacturer.

#### 6.4.2.3 Other power sources

For operation from other power sources the extreme values of power source voltage shall be agreed between the regulatory authority and the manufacturer.

## 6.5 Procedure for tests at extreme temperatures

For tests at the upper extreme of temperature, the EUT shall be placed in the test chamber and left switched off until thermal equilibrium is reached. The EUT shall then be switched on for half an hour in the high power transmit condition. At the end of this transmit period the necessary tests shall be carried out immediately.

For tests at the lower extreme of temperature, the EUT shall be placed in the test chamber and left switched off until thermal equilibrium is reached. The EUT shall then be switched to the standby or receive position for one minute. At the end of this one minute period the necessary tests shall be carried out immediately.

---

# 7 General conditions of measurement

## 7.1 Sequence of testing

Testing may be carried out on either one or two samples of the product, at the manufacturer's discretion.

Where one sample is used, environmental tests shall be carried out first, before tests are performed on the same equipment with respect to the other requirements of the present document.

Where two samples (sample A and sample B) are used, environmental tests shall be carried out on sample A, while sample B shall undergo the same pre-conditioning-vibration including any endurance tests, dry heat cycle, damp heat cycle, low temperature cycle-as sample A, but without the requirement to be subjected to performance checks during the pre-conditioning.

Following environmental tests/pre-conditioning both samples shall be subject to performance checks. If either sample should fail the performance checks this shall constitute an environmental test failure.

Emissions and immunity tests shall be carried out on sample B after environmental pre-conditioning.

Tests with respect to the other requirements of the present document shall be carried out on sample A after environmental tests are completed.

## 7.2 Test channels

For analogue speech, tests shall be made on channel 16 unless otherwise stated. For DSC, tests shall be made on channel 70 unless otherwise stated.

## 7.3 Squelch

Unless otherwise specified, the receiver squelch facility shall be made inoperative for the duration of testing.

## 7.4 Arrangements for test signals applied to the receiver input

Test signal sources shall be connected to the receiver in such a way that the EUT receiver RF input port is terminated with a non-reactive 50  $\Omega$  impedance, irrespective of whether one or more test signals are applied to the receiver simultaneously.

Where a wanted test signal is specified, the test signal source shall be set to supply a test signal on the nominal frequency of the test channel, as selected on the EUT receiver.

Test signals levels are expressed throughout the present document in terms of the emf at the terminals to be connected to the EUT receiver RF input port. Care shall be taken to determine whether level information displayed on test equipment is in terms of pd or emf, and to convert accordingly.

## 7.5 Normal test modulation of the receiver wanted signal

For the purposes of the present document, normal test modulation of the wanted test signal applied to the EUT receiver shall be modulation by a sinusoidal audio signal with a frequency of 1 000 Hz, to a peak frequency deviation of  $\pm 3$  kHz.

## 7.6 Arrangements for monitoring the receiver output

The EUT receiver shall be connected to the measuring equipment in such a way that EUT receiver analogue speech output port operates into a resistive load which simulates the receiver's normal operating load (the value of this load shall be stated by the manufacturer).

Unless stated otherwise the EUT receiver volume control shall be set to produce at least 50 % of the rated audio output power.

Unless stated otherwise the audio output signal shall be coupled via a psophometric weighting network conforming to ITU-T Recommendation O.41 [13] to a SINAD measuring instrument and an rms voltmeter having a -6 dB bandwidth of at least 20 kHz.

The EUT receiver DSC output should be monitored by means of the DSC information display. Where a manufacturer supplies additional ancillary equipment to demonstrate DSC capability, this equipment shall be included with the EUT inside the test environment.

## 7.7 Arrangements for test signals applied to the transmitter input

Unless stated otherwise, a signal generator shall be used to provide the audio frequency signal to modulate the transmitter. The signal generator shall be connected in place of the microphone transducer, and the signal shall be applied to the connection terminals normally used for the microphone transducer.

## 7.8 Normal test modulation of the transmitter

For the purposes of the present document, normal test modulation of the EUT transmitter shall be modulation by a sinusoidal audio signal with a frequency of 1 000 Hz, to a peak frequency deviation of  $\pm 3$  kHz.

## 7.9 Arrangements for monitoring the transmitter output

For transmit mode tests the EUT shall be connected to the measuring equipment in such a way that the EUT transmitter antenna port is terminated with a non-radiating non-reactive  $50 \Omega$  impedance.

Unless stated otherwise the RF output signal shall be coupled to a test suite comprising:

- a) a power measuring instrument;
- b) a deviation meter capable of measuring the peak deviation, including that due to any harmonics and intermodulation products which may be generated in the transmitter;
- c) a linear demodulator connected via a 6 dB per octave de-emphasis network with a time constant of at least  $750 \mu\text{s}$  to an rms voltmeter.

## 7.10 DSC encoder/decoder

Where the equipment under test does not include an integrated DSC encoder/decoder, the manufacturer shall supply as a part of the test equipment a suitable stand-alone DSC encoder/decoder, meeting the requirements of EN 300 338 [16], to be used in carrying out the tests dealing with DSC related parameters.

## 7.11 Standard test signals for DSC

Standard test signals shall consist of a series of identical call sequences, each of which contain a known number of information symbols: format specifier, address, category, identification, etc., see ITU-R Recommendation M.493-10 [8].

Standard test signals shall be of sufficient length for the measurements to be performed, or it shall be possible to repeat them without interruption to make the measurements.

## 7.12 Determination of symbol error ratio in the output of the receiver

The information content of the decoded call sequence to which forward error correction, interleaving, and check-sum information is applied, shall be divided into blocks, each of which corresponds to one information symbol in the applied test signal. The total number of incorrect information symbols relative to the total number of information symbols shall be registered.

## 7.13 Interpretation of the measurement results

The interpretation of the results recorded in a test report for the measurements described in the present document shall be as follows:

- the measured value related to the corresponding limit will be used to decide whether an equipment meets the requirements of the present document;
- the value of the measurement uncertainty for the measurement of each parameter shall be included in the test report;
- the recorded value of the measurement uncertainty shall be, for each measurement, equal to or lower than the figures in table 1.

For the test methods, according to the present document, the measurement uncertainty figures shall be calculated in accordance with ETR 028 [15] and shall correspond to an expansion factor (coverage factor)  $k = 1,96$  or  $k = 2$  (which provide confidence levels of respectively 95 % and 95,45 % in the case where the distributions characterizing the actual measurement uncertainties are normal (Gaussian)). Table 1 is based on such expansion factors.

**Table 1: Absolute measurement uncertainties: maximum values**

Parameter	Maximum uncertainty
RF frequency	$\pm 1 \times 10^{-7}$
RF power	$\pm 0,75$ dB
Maximum frequency deviation:	
- within 300 Hz to 6 kHz of audio frequency	$\pm 5$ %
- within 6 kHz to 25 kHz of audio frequency	$\pm 3$ dB
Deviation limitation	$\pm 5$ %
Adjacent channel power	$\pm 5$ dB
Conducted spurious emission of transmitter	$\pm 4$ dB
Audio output power	$\pm 0,5$ dB
Amplitude characteristics of receiver limiter	$\pm 1,5$ dB
Sensitivity at 20 dB SINAD	$\pm 3$ dB
Conducted emission of receiver	$\pm 3$ dB
Two-signal measurement	$\pm 4$ dB
Three-signal measurement	$\pm 3$ dB
Radiated emission of transmitter	$\pm 6$ dB
Radiated emission of receiver	$\pm 6$ dB
Transmitter transient time	$\pm 20$ %
Transmitter transient frequency	$\pm 250$ Hz
Receiver desensitisation (duplex operation)	$\pm 0,5$ dB

## 8 Performance checks

### 8.1 Performance checks - introduction

The environmental tests detailed in clause 9 and the immunity tests detailed in clause 11 rely upon performance checks being carried out upon the EUT as it is subjected to adverse environmental or electromagnetic conditions, in order to determine the ability of the EUT to perform satisfactorily under these conditions.

The purpose of this clause is to define the performance checks. Clauses 9 and 11 define when and how the performance checks are to be applied and interpreted.

Performance checks shall be carried out on channel 16. Transmitter checks shall be carried out with output power set at maximum. In all cases performance checks shall comprise the following clauses.

### 8.2 Performance check - transmitter frequency error

Arrangements for monitoring the transmitter output are specified in clause 7.9. The carrier frequency shall be measured in the absence of modulation.

The frequency error shall be within  $\pm 1,5$  kHz (for a definition of frequency error see clause 13.2.1).

### 8.3 Performance check - transmitter carrier power

Arrangements for monitoring the transmitter output are specified in clause 7.9. The power delivered to the antenna transmission line shall be measured.

The carrier power shall be between 6 W and 25 W (for a definition of carrier power see clause 13.3.1).

## 8.4 Performance check - transmitter audio frequency harmonic distortion of the emission

Arrangements for modulating the transmitter are specified in clause 7.7. Arrangements for monitoring the transmitter output are specified in clause 7.9. The transmitter shall be modulated with normal test modulation as specified in clause 7.8. The harmonic distortion of the audio frequency signal shall be measured.

The harmonic distortion shall not exceed 10 % (for a definition of audio frequency harmonic distortion see clause 13.7.1).

## 8.5 Performance check - receiver sensitivity

A wanted test signal at +12 dB $\mu$ V emf, modulated by the normal test modulation as specified in clause 7.5, shall be applied to the receiver RF input port as specified in clause 7.4. The receiver output shall be monitored as specified in clause 7.6, the SINAD ratio at the receiver audio output shall be measured.

The SINAD ratio shall be at least 20 dB.

---

# 9 Environmental tests

## 9.1 Procedure

Unless stated otherwise, the equipment shall be connected to an electrical power source during the periods for which it is specified that electrical tests shall be carried out. These tests shall be performed using the normal test voltage.

## 9.2 Vibration test

### 9.2.1 Definition

This test verifies the ability of the equipment to withstand vibration without resulting in mechanical weakness or degradation in performance.

### 9.2.2 Method of measurement

The EUT, complete with any shock and vibration absorbers with which it is provided, shall be clamped to the vibration table by its normal means of support and in its normal attitude. The EUT may be resiliently suspended to compensate for weight not capable of being withstood by the vibration table. Provision may be made to reduce or nullify any adverse effect on EUT performance which could be caused by the presence of an electromagnetic field due to the vibration unit.

The EUT shall be subjected to sinusoidal vertical vibration at all frequencies between:

- 2 Hz to 5 Hz and up to 13,2 Hz with an excursion of  $\pm 1 \text{ mm} \pm 10 \%$  (7 metres per second per second maximum acceleration at 13,2 Hz);
- 13,2 Hz to 100 Hz with a constant maximum acceleration of 7 metres per second per second.

The frequency sweep rate shall be 0,5 octaves/min in order to allow the detection of resonances in any part of the EUT as mounted.

A resonance search shall be carried out throughout the test. During the resonance search the EUT shall be externally observed, by unaided visual and aural means, for obvious signs of any resonances of components or sub-assemblies, that may affect the integrity of the EUT. Such observations shall be recorded in the test report. If any resonance, as measured by a sensor fixed to the outside of the EUT at the location where obvious signs of resonance have been observed, has a magnitude ratio  $\geq 5$  measured relative to the surface where the EUT is fastened, the EUT shall be subjected to a vibration endurance test at each resonant frequency at the vibration level specified in the test with a duration of two hours. When resonant frequencies with magnitude ratios  $\geq 5$  are harmonically related only the fundamental frequency shall be tested. If no resonance with magnitude ratio  $\geq 5$  occurs, the endurance test shall be carried out at one single observed frequency. If no resonance occurred, the endurance test shall be carried out at a frequency of 30 Hz.

Performance checks shall be carried out at least once during each endurance test period, and once before the end of each endurance test period.

The procedure shall be repeated with vibration in each of two mutually perpendicular directions in the horizontal plane.

After conducting the vibration tests, the equipment shall be inspected for any mechanical deterioration.

### 9.2.3 Requirement

The equipment shall meet the requirements of the performance checks.

There shall be no harmful deterioration of the equipment visible.

## 9.3 Temperature tests

### 9.3.1 Introduction

These tests verify the ability of the equipment to withstand extremes of temperature and humidity without resulting in mechanical weakness or degradation in performance.

### 9.3.2 General Procedure

The maximum rate of raising or reducing the temperature of the chamber in which the equipment is being tested shall be 1°C per minute.

### 9.3.3 Dry heat

#### 9.3.3.1 Definition

This test verifies the ability of the equipment to be operated at high ambient temperatures and to operate through temperature changes.

#### 9.3.3.2 Method of measurement

The EUT shall be placed in a chamber at normal room temperature and relative humidity. The EUT shall then be switched on, along with any climatic control devices with which it is provided. The temperature shall then be raised to  $+55^{\circ}\text{C} \pm 3^{\circ}\text{C}$  and maintained for a period of 10 to 16 hours.

The EUT shall then be subjected to the performance checks. The temperature of the chamber shall be maintained at  $+55^{\circ}\text{C} \pm 3^{\circ}\text{C}$  during the performance check.

At the end of the test, the EUT shall be returned to normal environmental conditions.

#### 9.3.3.3 Requirement

The equipment shall meet the requirements of the performance checks.



## 9.3.4 Damp heat

### 9.3.4.1 Definition

This test verifies the ability of the equipment to be operated under conditions of high humidity.

### 9.3.4.2 Method of measurement

The EUT shall be placed in a chamber at normal room temperature and relative humidity. The temperature shall be raised to  $+40^{\circ}\text{C} \pm 2^{\circ}\text{C}$ , and the relative humidity raised to  $93\% \pm 3\%$  over a period of three hours  $\pm 0,5$  hour. These conditions shall then be maintained for a period of 10 to 16 hours.

Any climatic control devices provided in the EUT may be switched on at the end of this period. The EUT shall be switched on thirty minutes later, or after such period as agreed by the manufacturer, and shall be kept operational for at least two hours during which period the EUT shall be subjected to the performance checks. The temperature and relative humidity of the chamber shall be maintained at  $+40^{\circ}\text{C} \pm 2^{\circ}\text{C}$  and  $93\% \pm 3\%$  respectively during the performance checks.

At the end of the test period and with the EUT still in the chamber, the chamber shall be brought to room temperature in not less than one hour, and the EUT shall then be returned to normal environmental conditions.

### 9.3.4.3 Requirement

The equipment shall meet the requirements of the performance checks.

## 9.3.5 Low temperature cycle

### 9.3.5.1 Definition

These tests verify the ability of the equipment to be operated at low temperatures, and to start up at low ambient temperatures.

### 9.3.5.2 Method of measurement

The EUT shall be placed in a chamber at normal room temperature and relative humidity. The temperature shall then be reduced to  $-15^{\circ}\text{C} \pm 3^{\circ}\text{C}$ , and maintained for a period of 10 to 16 hours.

Any climatic control devices provided in the EUT may be switched on at the end of this period. The EUT shall be switched on thirty minutes later, and shall be kept operational for at least two hours during which period the EUT shall be subjected to the performance checks. The temperature of the chamber shall be maintained at  $-15^{\circ}\text{C} \pm 3^{\circ}\text{C}$  during the performance checks.

At the end of the test the EUT shall be returned to normal environmental conditions.

### 9.3.5.3 Requirement

The equipment shall meet the requirements of the performance checks.

---

## 10 Emissions tests

### 10.1 General conditions for emissions tests

The individual tests listed in the following clauses shall be performed in accordance with the EMC standards referred to in each case.

Tests shall be carried out under normal test conditions, i.e. using the normal power source voltage as defined in clause 6.3.2 and under conditions of normal temperature and humidity as defined in clause 6.3.1.

Measurements shall be performed both with the EUT in receive mode and with the EUT in transmit mode using normal test modulation.

The test configuration and mode of operation of the EUT shall be as close as possible to the normal intended use, and shall be recorded in the test report.

An attempt shall be made to maximize the detected radiated emissions, e.g. by moving the cables of the equipment.

If the EUT is part of a system, or can be connected to ancillary equipment, then it shall be configured with at least the minimum necessary set of ancillary equipment to fully exercise the EUT ports.

If the EUT has a large number of ports, then a sufficient number of these shall be selected to simulate actual operational conditions and to ensure that all applicable different types of termination are covered.

EUT ports which are connected in normal operation shall be connected, either to ancillary equipment or to a representative length of cable terminated to simulate the impedance of the ancillary equipment.

EUT ports which are not normally connected, e.g. service connectors, shall not be connected to any cables for the purpose of emissions testing.

All RF ports shall be correctly terminated.

Where it is necessary to deviate from a normal and representative test configuration, e.g. in terms of port connections or cable lengths, in order to fully exercise the EUT, then due precautions shall be taken to ensure that the evaluation of the EUT is not affected.

### 10.2 Conducted emissions from power ports

#### 10.2.1 Definition

This test assesses the ability of the EUT to limit the coupling of its internal noise to the AC or DC power port.

#### 10.2.2 Test method

The test method shall be in accordance with EN 60945 [17].

The power port of the EUT shall be connected to an Artificial Mains Network complying with CISPR 16-1 [14] by means of a screened cable which shall not exceed 0,8 m in length.

If the EUT consists of more than one unit with individual AC and/or DC power ports, power ports of the same nominal supply voltage shall be connected in parallel to the Artificial Mains Network.

The setting of controls which may affect the level of conducted interference shall be varied in order to ascertain the maximum emission level.

The RF voltage appearing across the defined impedance provided by the Artificial Mains Network connected to the power supply terminals of the EUT, in the frequency range from 10 kHz to 30 MHz, shall be measured by means of a quasi-peak measuring receiver complying with CISPR 16-1 [14]. The measuring bandwidth shall be:

- 200 Hz in the frequency range 10 kHz to 150 kHz;
- 9 kHz to 10 kHz in the frequency range 150 kHz to 30 MHz.

### 10.2.3 Limits

The level of any conducted spurious signal shall not exceed the values given in figure 2.

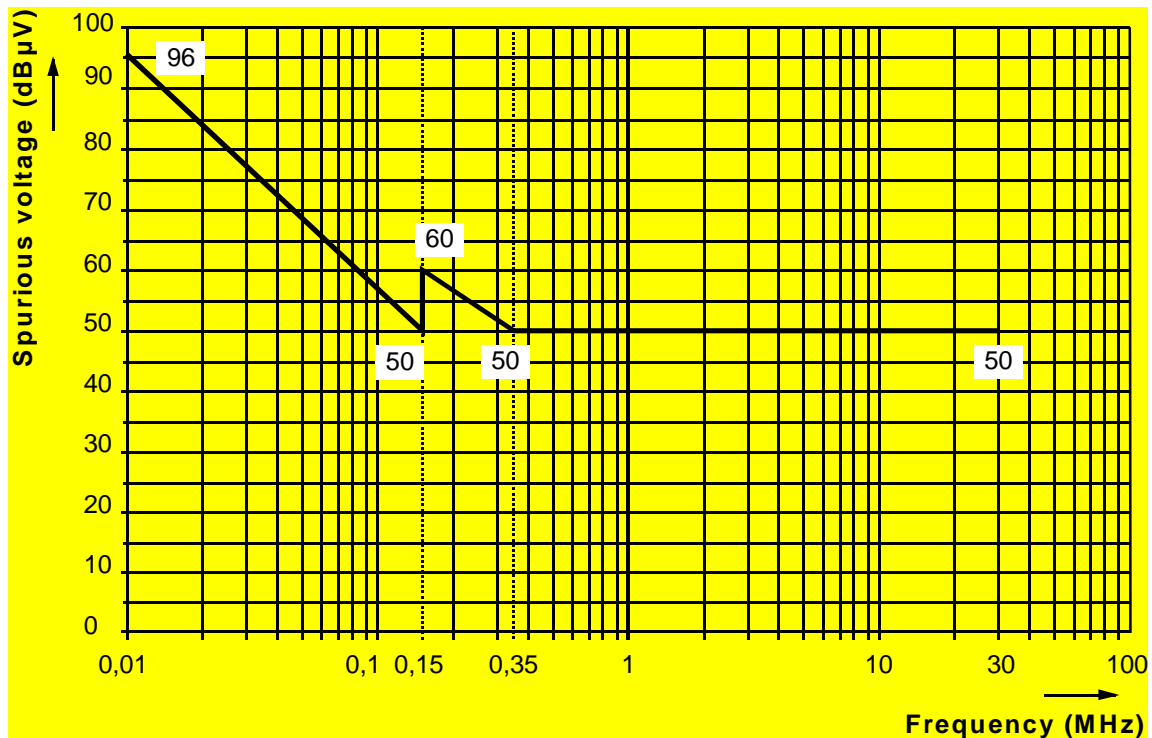

Figure 2: Maximum permissible level (quasi-peak) of conducted emissions into the mains

### 10.3 Radiated emissions from the enclosure port

The present document does not address the testing of ancillary equipment on a stand-alone basis, i.e. separately from the radio equipment which it is to be used in connection with.

Testing for radiated emissions from the enclosure port of the combination of radio and ancillary equipment is dealt with in clause 12.2 on cabinet radiation.

---

## 11 Immunity tests

### 11.1 General conditions for immunity tests

#### 11.1.1 Introduction

The individual tests called up in the following clauses shall be performed in accordance with the EMC standards referred to in each case.

Tests shall be carried out under normal test conditions, i.e. using the normal power source voltage as defined in clause 6.3.2 and under conditions of normal temperature and humidity as defined in clause 6.3.1.

Measurements shall be performed both with the EUT in receive mode and with the EUT in transmit mode.

#### 11.1.2 Performance assessment

To enable the performance of the equipment to be assessed, the manufacturer must supply the following information to be recorded in the test report:

- a listing of the user control functions and stored data required for normal operation of the EUT, and details of the method to be used to assess whether these have been lost after an immunity test;
- an exhaustive list of ports, classified as either power, signal/control or antenna ports, with associated maximum cable lengths; power ports shall further be classified as AC or DC power;
- the 6 dB bandwidth of the IF filter immediately preceding the demodulator;
- any ancillary equipment to be combined with the radio equipment for testing, where applicable;
- details of any test equipment delivered to enable the assessment of the EUT;
- details of the frequency bands over which the equipment is intended to operate.

#### 11.1.3 Ancillary equipment

Assessment of ancillary equipment separately from the EUT with which it is associated is outside the scope of the present document.

For ancillary equipment tested in conjunction with the EUT, the behaviour of the EUT shall be used to determine compliance.

At the manufacturer's discretion ancillary equipment may be tested and assessed separately against the requirements of EN 60945 [17], in which case compliance may enable the ancillary equipment to be used with other appropriate equipment.

#### 11.1.4 Test configuration

The test configuration and mode of operation of the EUT shall be as close as possible to the normal intended use, and shall be recorded in the test report.

If the EUT is part of a system, or can be connected to ancillary equipment, then it shall be configured with at least the minimum necessary set of ancillary equipment to fully exercise the EUT ports.

If the EUT has a large number of ports, then sufficient of these shall be selected to simulate actual operational conditions and to ensure that all applicable different types of termination are covered.

EUT Ports which are connected in normal operation shall be connected, either to ancillary equipment or to a representative length of cable terminated to simulate the impedance of the ancillary equipment.

All RF ports shall be correctly terminated.

EUT Ports which are not normally connected, e.g. service connectors, shall not be connected to any cables for the purposes of immunity testing.

Where it is necessary to deviate from a normal and representative test configuration, e.g. in terms of port connections or cable lengths, in order to fully exercise the EUT, then due precautions shall be taken to ensure that the evaluation of the EUT is not affected.

## 11.1.5 Arrangements for test signals

### 11.1.5.1 General arrangements

Adequate measures shall be taken to prevent immunity test signals from affecting either the measuring equipment or the signal sources for the wanted signals.

### 11.1.5.2 Arrangements for test signals applied to the transmitter input

For tests in transmit mode the EUT transmitter shall be modulated with normal test modulation as defined in clause 7.8.

The signal source used to modulate the EUT transmitter shall be located outside the test environment, (unless the transmitter is modulated by its own internal source).

### 11.1.5.3 Arrangements for monitoring the transmitter output

For tests in transmit mode the wanted RF output signal from the EUT transmitter shall be monitored as defined in clause 7.9.

The measuring equipment used to monitor the wanted RF output signal from the EUT transmitter shall be located outside the test environment.

The wanted RF output signal shall be delivered from the EUT transmitter antenna port to the external measuring equipment by a shielded transmission line, such as a coaxial cable. Adequate measures shall be taken to minimize the effect of unwanted common mode currents on the external conductor of the transmission line at the point of entry to the EUT transmitter.

### 11.1.5.4 Arrangements for test signals applied to the receiver input

For tests in receive mode the EUT receiver shall be supplied with a wanted RF input signal connected as defined in clause 7.4. The wanted signal shall be modulated with normal test modulation as specified in clause 7.5.

The signal source used to provide the EUT receiver with a wanted RF input signal shall be located outside the test environment.

The wanted RF input signal shall be delivered from the external RF signal source to the EUT antenna port by a shielded transmission line, such as a coaxial cable. Adequate measures shall be taken to minimize the effect of unwanted common mode currents on the external conductor of the transmission line at the point of entry to the EUT receiver.

### 11.1.5.5 Arrangements for monitoring the receiver output

For tests in receive mode the audio output signal from the EUT receiver shall be monitored as defined in clause 7.6.

The measuring equipment used to monitor the output signal from the EUT receiver shall be located outside the test environment.

The EUT receiver analogue speech output signal shall be coupled via an electrically non-conductive means (e.g. an acoustic tube) to the appropriate external measuring equipment. The means of connecting the receiver output signal to the measuring equipment shall be recorded in the test report.

The EUT receiver DSC output should be monitored by means of a camera set up to read the DSC information display. Where a manufacturer supplies additional ancillary equipment to demonstrate DSC capability, this equipment shall be included with the EUT inside the test environment.

Precautions shall be taken to avoid or minimize any effects upon the test due to the coupling means employed.

## 11.1.6 Exclusion bands

### 11.1.6.1 Definition

During immunity tests with continuous phenomena (conducted and radiated RF immunity tests), the EUT shall not be subjected to the RF disturbance signal within the frequency band defined as the receiver exclusion band in the case of receive mode tests, or the frequency band defined as the transmitter exclusion band in the case of transmit mode tests.

### 11.1.6.2 Transmitter exclusion band for immunity tests

For the purposes of immunity testing the transmitter exclusion band is defined as a 100 kHz segment of the spectrum centred at the nominal carrier frequency of the transmitter.

### 11.1.6.3 Receiver exclusion band for immunity tests

For the purposes of immunity testing the receiver exclusion band is defined as the operating frequency band of the receiver, as declared by the manufacturer, extended at each end by 5 % of the end-of-band frequency.

## 11.1.7 Assessment of receiver responses

Responses of receivers which are narrow-band responses (spurious responses) at discrete frequencies, occurring during immunity tests for continuous phenomena, shall be identified by the following method:

- If during an immunity test the presence of the test RF electromagnetic disturbance (the interfering signal) causes a degradation of the performance of the receiver such that it fails the performance check, it is necessary to establish whether this is due to a narrow-band response or to a wideband phenomenon. Therefore, the frequency of the interfering signal is increased by an amount equal to twice the nominal 6 dB bandwidth of the EUT receiver IF filter immediately preceding the demodulator of the receiver, as declared by the manufacturer. The test is repeated with the frequency of the interfering signal decreased by the same amount.
- If the degradation of the receiver performance disappears when the interfering signal is offset in this way, then the response is considered to be a narrow-band response. If the degradation remains this may be due to the fact that the offset has made the frequency of the interfering signal correspond to the frequency of another narrow-band response. Under these circumstances the procedure is repeated with the offset of frequency of the interfering signal increased to two and a half times that used above.
- If the degradation of the receiver performance still remains, then the response is considered to be a wideband phenomena and therefore an EMC immunity problem, and the equipment fails the test.

Narrow-band responses are dealt with fully in clause 14.7, and shall be disregarded during immunity testing.

## 11.2 Performance criteria

### 11.2.1 Categories

One of the following three categories of performance criteria is applicable to determine whether the EUT meets the requirements of each immunity test:

- performance criteria A for continuous phenomena;
- performance criteria B for transient phenomena;
- performance criteria C for power supply failure.

## 11.2.2 Performance criteria A for continuous phenomena

The following general performance criteria shall apply in the case of continuous phenomena.

The EUT shall be subjected to the immunity performance check during and after the test.

During the test sequence the EUT shall not transmit unintentionally.

During and after the test, the EUT shall continue to operate as intended. No degradation of performance or loss of function is allowed below the level defined by the immunity performance check and the technical specification published by the manufacturer.

No change to the selected mode of operation of the EUT or to its stored data shall occur as a result of the test.

## 11.2.3 Performance criteria B for transient phenomena

The following general performance criteria shall apply in the case of transient phenomena.

The EUT shall be subjected to the immunity performance check after the test.

During the test sequence the EUT shall not transmit unintentionally, however some degradation of performance is permissible.

After the test, the EUT shall continue to operate as intended. No degradation of performance or loss of function is allowed below the level defined by the immunity performance check and the technical specification published by the manufacturer.

No change to the selected mode of operation of the EUT or to its stored data shall occur as a result of the test.

## 11.2.4 Performance criteria C for power supply failure

The following general performance criteria shall apply in the case of power supply failure.

The EUT shall be subjected to the immunity performance check after the test.

During the test sequence the EUT shall not transmit unintentionally.

Temporary loss of function will occur during the test sequence.

After the test, normal function and performance of the EUT, as defined by the immunity performance check and the technical specification published by the manufacturer, shall be either self-recoverable or able to be restored by operation of user controls.

No change to the EUT stored data shall occur as a result of the test.

## 11.2.5 Immunity performance check

An immunity performance check shall be a performance check as defined in clause 8, with the additional requirements detailed in clause 11.1 in respect of test conditions, EUT configuration, and the interconnection of the EUT and the test equipment fully observed.

The immunity performance check is used in conjunction with the appropriate performance criteria to determine whether the EUT meets the requirements of an immunity test.

## 11.3 Electrostatic discharge immunity (ESD)

### 11.3.1 Definition

This test assesses the ability of the EUT to operate as intended in the event of an electrostatic discharge.

### 11.3.2 Test method

The test method shall be in accordance with IEC 61000-4-2 [18].

The test generator, test set-up and test procedure shall be in accordance with IEC 61000-4-2 [18]. The test levels shall be 6 kV contact discharge and 8 kV air discharge. All other details, including intermediate test levels, are contained in IEC 61000-4-2 [18].

The test shall be performed with ten single discharges applied to each test point. Ten test points shall be chosen on exposed surfaces on any unit of the EUT including, where appropriate, knobs and other protrusions or projecting parts accessible to the user in normal operation.

Care shall be taken not to apply these discharges to the conductive pins of connectors.

### 11.3.3 Performance criteria

Performance criteria B for transient phenomena, clause 11.2.3, shall apply.

During the test sequence the EUT shall be monitored for unintentional transmissions.

After the test the EUT shall be checked for continuity of the selected mode of operation and stored data, subjected to the immunity performance check, and checked for normal function against the manufacturers technical specification.

## 11.4 RF electromagnetic fields in the frequency range 80 MHz to 2 GHz

### 11.4.1 Definition

This test assesses the ability of the EUT to operate as intended in the presence of an RF electromagnetic disturbance impinging upon the enclosure.

### 11.4.2 Test method

The test method shall be in accordance with IEC 61000-4-3 [19].

The following requirements and evaluation of test results shall apply:

- the test level of the field disturbance signal shall be 10 V/m (measured unmodulated); the test signal shall be amplitude modulated to a depth of 80 % by a sinusoidal audio signal of 400 Hz;
- the test shall be performed over the frequency range 80 MHz – 2 GHz with the exception of the transmitter exclusion band, clause 11.1.6.2, or of the receiver exclusion band, clause 11.1.6.3, as appropriate;
- stepped increments of the field disturbance signal frequency shall be increments of 1 % of the momentary used frequency;
- EUT receiver responses occurring at discrete frequencies which are narrow-band responses, clause 11.1.7, shall be disregarded;
- the frequencies of the field disturbance signal selected and used during the test shall be recorded in the test report.



### 11.4.3 Performance criteria

Performance criteria A for continuous phenomena, clause 11.2.2, shall apply.

During the test sequence the EUT shall be monitored for unintentional transmissions.

During and after the test the EUT shall be checked for continuity of the selected mode of operation and stored data, subjected to the immunity performance check, and checked for normal function against the manufacturers technical specification.

## 11.5 Fast transient, common mode

### 11.5.1 Definition

This test assesses the ability of the EUT to operate as intended in the event of fast transients or bursts present on power, signal or control ports.

### 11.5.2 Test method

This test shall be performed on the AC power ports of the EUT and associated ancillary equipment.

This test shall additionally be performed on signal and control ports and DC power ports of the EUT and associated ancillary equipment if these ports may be connected to cables longer than 3 m.

All ports which were not tested because the manufacturer declared them not intended for use with cables longer than 3 m shall be listed in the test report.

The test method shall be in accordance with EN 61000-4-4 [20].

A test generator complying with clause 6.1.1 of EN 61000-4-4 [20] shall be used. The induction of the interference shall be:

- to AC/DC power ports by a coupling/decoupling network complying with clause 6.2 of EN 61000-4-4 [20];
- to signal and control ports by a capacitive coupling clamp complying with clause 6.6.3 of EN 61000-4-4 [20].

The test level shall be 2 kV. The test voltage shall be applied as a 15 ms burst every 300 ms for a duration of three minutes each for both positive and negative polarity of the test voltage.

For AC and DC power ports the transients shall be applied (in parallel) to all the wires in the cable with reference to the cabinet reference ground (true common mode). The source impedance shall be 50  $\Omega$ .

### 11.5.3 Performance criteria

Performance criteria B for transient phenomena, clause 11.2.3, shall apply.

During the test sequence the EUT shall be monitored for unintentional transmissions.

After the test the EUT shall be checked for continuity of the selected mode of operation and stored data, subjected to the immunity performance check, and checked for normal function against the manufacturers technical specification.

## 11.6 Conducted disturbances on power ports (RF common mode)

### 11.6.1 Definition

This test assesses the ability of the EUT to operate as intended in the presence of an RF electromagnetic disturbance on the input/output ports.

## 11.6.2 Test method

This test shall be performed on the AC power ports of the EUT and associated ancillary equipment.

This test shall additionally be performed on signal and control ports and DC power ports of the EUT and associated ancillary equipment if these ports may be connected to cables longer than 3 m.

All ports which were not tested because the manufacturer declared them not intended for use with cables longer than 3 m shall be listed in the test report.

The test method shall be in accordance with IEC 61000-4-6 [22].

The following requirements and evaluation of test results shall apply:

- the disturbance signal shall be applied to the power supply line by a coupling/decoupling network complying with clause 6.2.2.1 of IEC 61000-4-6 [22];
- the disturbance signal shall be applied to signal input/output and control lines by direct injection as described in clause 6.2.1 of IEC 61000-4-6 [22];
- the test level shall be severity level 2 as given in IEC 61000-4-6 [22], corresponding to 3 V rms unmodulated; the test signal shall be amplitude modulated to a depth of 80 % by a sinusoidal audio signal of 400 Hz;
- the test shall be performed over the frequency range 150 kHz to 80 MHz with the exception of the transmitter exclusion band, clause 11.1.6.2, or of the receiver exclusion band, clause 11.1.6.3, as appropriate;
- for receivers the stepped increments of the disturbance signal frequency shall be increments of 50 kHz in the frequency range 150 kHz to 5 MHz and increments of 1 % of the momentary frequency in the frequency range 5 MHz to 80 MHz;
- for transmitters the stepped increments of the disturbance signal frequency shall be increments of 500 kHz in the frequency range 150 kHz to 5 MHz and increments of 10 % of the momentary frequency in the frequency range 5 MHz to 80 MHz;
- additionally a test shall be performed with a test level of 10 V rms at the following frequencies:
  - 2 MHz;
  - 3 MHz;
  - 4 MHz;
  - 6,2 MHz
  - 8,2 MHz;
  - 12,2 MHz;
  - 16,5 MHz;
  - 18,8 MHz;
  - 22 MHz;
  - 25 MHz;
- EUT receiver responses occurring at discrete frequencies which are narrow-band responses, clause 11.1.7, shall be disregarded;
- the frequencies of the disturbance signal selected and used during the test shall be recorded in the test report.

### 11.6.3 Performance criteria

Performance criteria A for continuous phenomena, clause 11.2.2, shall apply.

During the test sequence the EUT shall be monitored for unintentional transmissions.

During and after the test the EUT shall be checked for continuity of the selected mode of operation and stored data, subjected to the immunity performance check, and checked for normal function against the manufacturers technical specification.

## 11.7 Power supply short term variations

### 11.7.1 Definition

This test assesses the ability of the EUT to operate as intended when being subjected to power supply short term variations present on the AC power input ports.

### 11.7.2 Test method

This test shall be performed on the AC power port of the EUT and associated ancillary equipment.

The test method shall be in accordance with EN 60945 [17]. The EUT shall be subject to the following power supply variations relative to the nominal value once per minute for the duration of ten minutes each:

- a) supply voltage = nominal supply voltage +  $(20 \pm 1)$  %,  
duration  $1,5 \text{ s} \pm 0,2 \text{ s}$ ;  
supply frequency = nominal supply frequency +  $(10 \pm 0,5)$  %,  
duration  $5 \text{ s} \pm 0,5 \text{ s}$ ;  
superimposed;
- b) supply voltage = nominal supply voltage –  $(20 \pm 1)$  %,  
duration  $1,5 \text{ s} \pm 0,2 \text{ s}$ ;  
supply frequency = nominal supply frequency –  $(10 \pm 0,5)$  %,  
duration  $5 \text{ s} \pm 0,5 \text{ s}$ ;  
superimposed.

The voltage and frequency variation rise and decay times are  $0,2 \text{ s} \pm 0,1 \text{ s}$  (from 10 % to 90 %).

All other details are contained in IEC 61000-4-11 [23].

### 11.7.3 Performance criteria

Performance criteria B for transient phenomena, clause 11.2.3, shall apply.

During the test sequence the EUT shall be monitored for unintentional transmissions.

After the test the EUT shall be checked for continuity of the selected mode of operation and stored data, subjected to the immunity performance check, and checked for normal function against the manufacturers technical specification.

## 11.8 Power supply failure

### 11.8.1 Definition

This test assesses the ability of the EUT to operate as intended after being subjected to interruptions in the power supply.

## 11.8.2 Test method

The EUT shall be subjected to three breaks in the power supply each of 60 s duration as defined in IEC 61000-4-11 [23].

## 11.8.3 Performance criteria

Performance criterion C, clause 11.2.4, shall apply.

During the test sequence the EUT shall be monitored for unintentional transmissions.

After the test the EUT may be restored to normal function by operation of user controls if necessary. The EUT shall be checked for continuity of stored data, subjected to the immunity performance check, and checked for normal function against the manufacturers technical specification.

## 11.9 Surge

### 11.9.1 Definition

These tests assess the ability of the EUT to operate as intended in the event of surges on the AC power input ports.

### 11.9.2 Test method

This test shall be performed on the AC power input port of the EUT and associated ancillary equipment.

The test method shall be in accordance with IEC 61000-4-5 [21].

A combination wave (hybrid) generator complying with clause 6.1 of IEC 61000-4-5 [21] in combination with a coupling/decoupling network complying with clause 6.3 of IEC 61000-4-5 [21] shall be used.

The following requirements and evaluation of test results shall apply:

- the test voltage shall be 0,5 kV line-to-line and 1 kV line-to-ground with the output impedance of the surge generator as given in the IEC 61000-4-5 [21]; the test voltage shall be applied with a repetition rate of 1 pulse per minute for a duration of five minutes each for both positive and negative polarity of the test voltage;
- the test generator shall provide the 1,2/50  $\mu$ s pulse as defined in IEC 61000-4-5 [21].

### 11.9.3 Performance criteria

Performance criteria B for transient phenomena, clause 11.2.3, shall apply.

During the test sequence the EUT shall be monitored for unintentional transmissions.

After the test the EUT shall be checked for continuity of the selected mode of operation and stored data, subjected to the immunity performance check, and checked for normal function against the manufacturers technical specification.

## 12 Cabinet radiation and antenna port spurious emissions

### 12.1 Conducted spurious emissions conveyed to the antenna

#### 12.1.1 Definition

Conducted spurious emissions from the transmitter are emissions present at the transmitter RF output port on frequencies which are outside the necessary bandwidth, the level of which may be reduced without affecting the transmission of information; these include harmonic emissions, parasitic emissions, intermodulation products and frequency conversion products, but exclude out of band emissions.

Conducted spurious emissions from the receiver are emissions present at the receiver RF input port at any frequency.

#### 12.1.2 Method of measurement

Measurements shall be made with the EUT in transmit mode and with the EUT in standby or receive mode.

Measurements shall be made using a tuned radio measuring instrument or a spectrum analyser.

The level of spurious emissions shall be measured as the power level of any discrete signal appearing at the EUT antenna port.

The EUT shall be connected to the measuring instrument in such a way that the EUT antenna port is presented with a non-radiating non-reactive 50  $\Omega$  impedance.

For transmit mode tests the EUT shall be switched on in transmit mode without modulation, and the measuring instrument shall be tuned over the frequency range from 9 kHz to 4 GHz, excluding the channel on which the transmitter is operating and its adjacent channels.

For receive or standby mode tests the EUT shall be switched on in the appropriate mode, and the measuring instrument shall be tuned over the frequency range from 9 kHz to 4 GHz.

The reference bandwidths for spurious emissions shall be in accordance with ITU-R Recommendation SM.329-8 [10], as follows:

- 1 kHz between 9 kHz and 150 kHz;
- 10 kHz between 150 kHz and 30 MHz;
- 100 kHz between 30 MHz and 1 GHz;
- 1 MHz above 1 GHz.

#### 12.1.3 Limit

The power of any conducted spurious emission on any discrete frequency shall not exceed the values given in table 2.

**Table 2: Power limits for conducted spurious emissions**

frequency range	9 kHz to 1 GHz	1 GHz to 4 GHz
transmit mode	0,25 $\mu$ W (-36 dBm)	1,00 $\mu$ W (-30 dBm)
standby or receive mode	2,0 nW (-57 dBm)	20,0 nW (-47 dBm)

## 12.2 Cabinet radiation

### 12.2.1 Definition

This test shall be performed on a representative configuration of the radio equipment or a representative configuration of the combination of radio and ancillary equipment.

This test assesses the ability of the EUT to limit unwanted emissions from the enclosure port. Unwanted or spurious emissions are emissions at frequencies other than those of the carrier and sidebands associated with normal test modulation.

The level of cabinet radiation is specified as the radiated power of any discrete signal radiated by the cabinet and structure of the equipment.

### 12.2.2 Method of measurement

Measurements shall be made with the EUT in transmit mode and with the EUT in standby or receive mode.

On a test site, conforming to annex C, the EUT shall be placed at the specified height on a non-conducting support and in the position closest to normal use as declared by the manufacturer.

The EUT antenna connector shall be connected to a non-reactive non-radiating 50  $\Omega$  termination.

The test antenna shall be orientated for vertical polarisation.

The output of the test antenna shall be connected to a tuned radio measuring instrument or a spectrum analyser.

For transmit mode tests the EUT shall be switched on in transmit mode without modulation, and the measuring receiver shall be tuned over the frequency range 30 MHz to 4 GHz, except for the channel on which the transmitter is intended to operate and its adjacent channels.

For receive or standby mode tests the EUT shall be switched on in the appropriate mode, and the measuring receiver shall be tuned over the frequency range 30 MHz to 4 GHz.

The reference bandwidths for spurious emissions shall be in accordance with ITU-R Recommendation SM.329-8 [10], as follows:

- 1 kHz between 9 kHz and 150 kHz;
- 10 kHz between 150 kHz and 30 MHz;
- 100 kHz between 30 MHz and 1 GHz;
- 1 MHz above 1 GHz.

At each frequency at which a spurious component is detected:

- a) the test antenna shall be raised and lowered through the specified range of heights, and finally adjusted for the maximum signal level indication on the measuring receiver;
- b) the EUT shall then be rotated through 360° in the horizontal plane, and finally adjusted for the maximum signal level indication on the measuring receiver;
- c) the maximum signal level indication on the measuring receiver shall be noted;
- d) the transmitter shall be replaced by a calibrated substitution antenna as defined in annex C;
- e) the substitution antenna shall be orientated for vertical polarisation and the length of the substitution antenna shall be adjusted to correspond to the frequency of the spurious component detected;
- f) the substitution antenna shall be connected to a calibrated signal generator;
- g) the frequency of the calibrated signal generator shall be set to the frequency of the spurious component detected;

- h) if necessary the input attenuator setting of the measuring receiver shall be adjusted in order to increase the sensitivity of the measuring receiver;
- i) the test antenna shall be raised and lowered through the specified range of heights to ensure that the maximum signal is received;
- j) the input signal to the substitution antenna shall be adjusted to produce a level, detected by the measuring receiver, equal to the level noted while the spurious component was measured (taking into account any change of input attenuator setting of the measuring receiver);
- k) the input power level to the substitution antenna, and any change of input attenuator setting of the measuring receiver, shall be recorded;
- l) the measurement shall be repeated with the test antenna and the substitution antenna orientated for horizontal polarisation.

At each spurious emission frequency the measurement result is derived from the larger of the two power levels recorded, for horizontal and for vertical polarisation, at the input to the substitution antenna. The measurement shall be corrected for the gain of the substitution antenna in dBd (gain relative to a tuned half-wave dipole), and for any change to the input attenuation of the measuring receiver between the EUT and the substitution phases of the measurement.

Measurements shall be repeated for each mode of operation of the EUT, i.e. with the transmitter in stand-by mode, and with the EUT in receive mode if this is different.

### 12.2.3 Limits

The power of any radiated spurious emission on any discrete frequency shall not exceed the values given in table 3.

**Table 3: Power limits for radiated spurious emissions**

frequency range	30 MHz to 1 GHz	1 GHz to 4 GHz
transmit mode	0,25 $\mu$ W (-36 dBm)	1,00 $\mu$ W (-30 dBm)
standby or receive mode	2,0 nW (-57 dBm)	20,0 nW (-47 dBm)

---

## 13 Transmitter

### 13.1 General conditions

All tests on the transmitter shall be carried out with output power set at maximum, except where otherwise stated.

### 13.2 Frequency error

#### 13.2.1 Definition

Frequency error is the difference between the measured carrier frequency and its nominal value.

#### 13.2.2 Method of measurement

Arrangements for monitoring the transmitter output are specified in clause 7.9. The carrier frequency shall be measured in the absence of modulation.

Measurements shall be made with the output power set at maximum and also with the output power set at minimum.

This test shall be carried out under normal test conditions and under extreme test conditions, as specified in clauses 6.3 and 6.4 respectively.

### 13.2.3 Limits

The frequency error shall be within  $\pm 1,5$  kHz.

## 13.3 Carrier power

### 13.3.1 Definitions

Carrier power is the mean power delivered to the antenna transmission line during one radio frequency cycle in the absence of modulation.

Maximum output power shall be the rated output power declared by the manufacturer.

### 13.3.2 Method of measurement

Arrangements for monitoring the transmitter output are specified in clause 7.9. The power delivered to the antenna transmission line shall be measured with the output power set at maximum and also with the output power set at minimum.

Measurements shall be made on channel 16, and also on the highest frequency and lowest frequency.

This test shall be carried out under normal test conditions and under extreme test conditions, as specified in clauses 6.3 and 6.4 respectively.

### 13.3.3 Limits

#### 13.3.3.1 General

The following limits apply to channel 16, and to any channels of the International VHF maritime mobile band, as defined in Appendix S18 to the Radio Regulations [6].

#### 13.3.3.2 Normal test conditions

Measured under normal test conditions with the output power set at maximum, the carrier power shall be between 6 W and 25 W, and shall not differ by more than 1,5 dB from the rated output power as declared by the manufacturer.

Measured under normal test conditions with the output power set at minimum, the carrier power shall be between 0,1 W and 1 W.

#### 13.3.3.3 Extreme test conditions

Measured under extreme test conditions with the output power set at maximum, the carrier power shall remain between 6 W and 25 W, and shall be within +2 dB, -3 dB of the rated output power as declared by the manufacturer.

Measured under extreme test conditions with the output power set at minimum, the carrier power shall remain between 0,1 W and 1 W.

## 13.4 Frequency deviation

### 13.4.1 Definition

Frequency deviation is the difference between the instantaneous frequency of the modulated radio frequency signal and the carrier frequency.



## 13.4.2 Maximum permissible frequency deviation

### 13.4.2.1 Method of measurement

Arrangements for modulating the transmitter are specified in clause 7.8. Arrangements for monitoring the transmitter output are specified in clause 7.9.

The transmitter shall be modulated with an audio tone at a level 20 dB above that required to produce normal test modulation as specified in clause 7.8. The frequency of this tone shall then be varied between 100 Hz and 3 kHz while its level is kept constant.

The peak frequency deviation shall be measured over this range.

Measurements shall be made with the output power set at maximum and also with the output power set at minimum.

### 13.4.2.2 Limits

The maximum permissible peak frequency deviation shall be  $\pm 5$  kHz.

## 13.4.3 Reduction of frequency deviation at modulation frequencies above 3 kHz

### 13.4.3.1 Method of measurement

Arrangements for modulating the transmitter are specified in clause 7.8. Arrangements for monitoring the transmitter output are specified in clause 7.9.

The transmitter shall be modulated with an audio tone at a level required to produce normal test modulation as specified in clause 7.8. The frequency of this tone shall then be varied between 3 kHz and 25 kHz while its level is kept constant.

The peak frequency deviation shall be measured over this range.

### 13.4.3.2 Limits

For modulating tones between 3 kHz and 6 kHz the peak frequency deviation shall not exceed that measured with a modulating tone at 3 kHz.

For a modulating tone at 6 kHz, the peak frequency deviation shall not exceed  $\pm 1,5$  kHz, as shown in figure 3.

For modulating tones between 6 kHz and 25 kHz the peak frequency deviation shall not exceed a limit described by a 14 dB per octave roll-off starting at the point where the modulating tone is 6 kHz and the frequency deviation is  $\pm 1,5$  kHz, as shown in figure 3 (frequency deviation in dB).

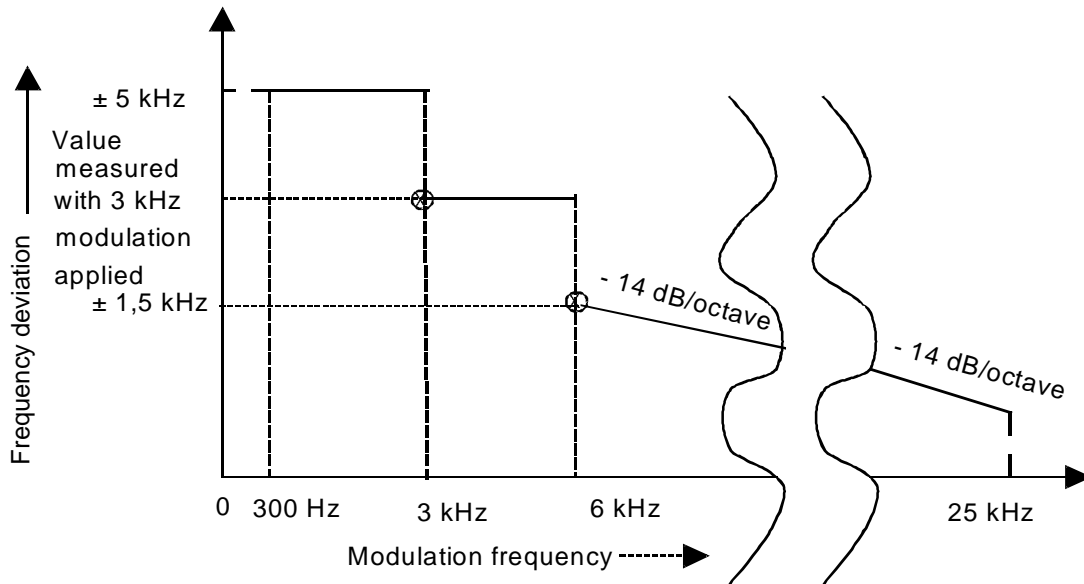

**Figure 3: Frequency deviation limits**

## 13.5 Sensitivity of the modulator including the microphone

### 13.5.1 Definition

This measurement characterizes the capability of the transmitter to produce sufficient modulation when an audio signal corresponding to the normal mean speech level is applied to the microphone.

### 13.5.2 Method of measurement

An acoustic signal with a frequency of 1 kHz and a sound level of 94 dBA shall be applied to the EUT microphone. The resulting peak frequency deviation shall be measured.

### 13.5.3 Limits

The peak frequency deviation shall be between  $\pm 1,5$  kHz and  $\pm 3$  kHz.

## 13.6 Audio frequency response

### 13.6.1 Definition

The audio frequency response is the peak frequency deviation of the transmitter as a function of the modulating frequency.

### 13.6.2 Method of measurement

Arrangements for modulating the transmitter are specified in clause 7.8. Arrangements for monitoring the transmitter output are specified in clause 7.9.

A modulating tone at 1 kHz shall be applied to the transmitter and the audio input level shall be adjusted so that the peak frequency deviation of the transmitter is  $\pm 1$  kHz. This is the reference point in figure 4 (i.e. 1 kHz corresponds to 0 dB).

The modulating tone shall then be varied between 300 Hz and 3 kHz, while its level is kept constant. The peak frequency deviation shall be measured over this range.

### 13.6.3 Limits

The audio frequency response shall be within +1 dB and -3 dB of a 6 dB per octave line passing through the reference point, as shown in figure 4.

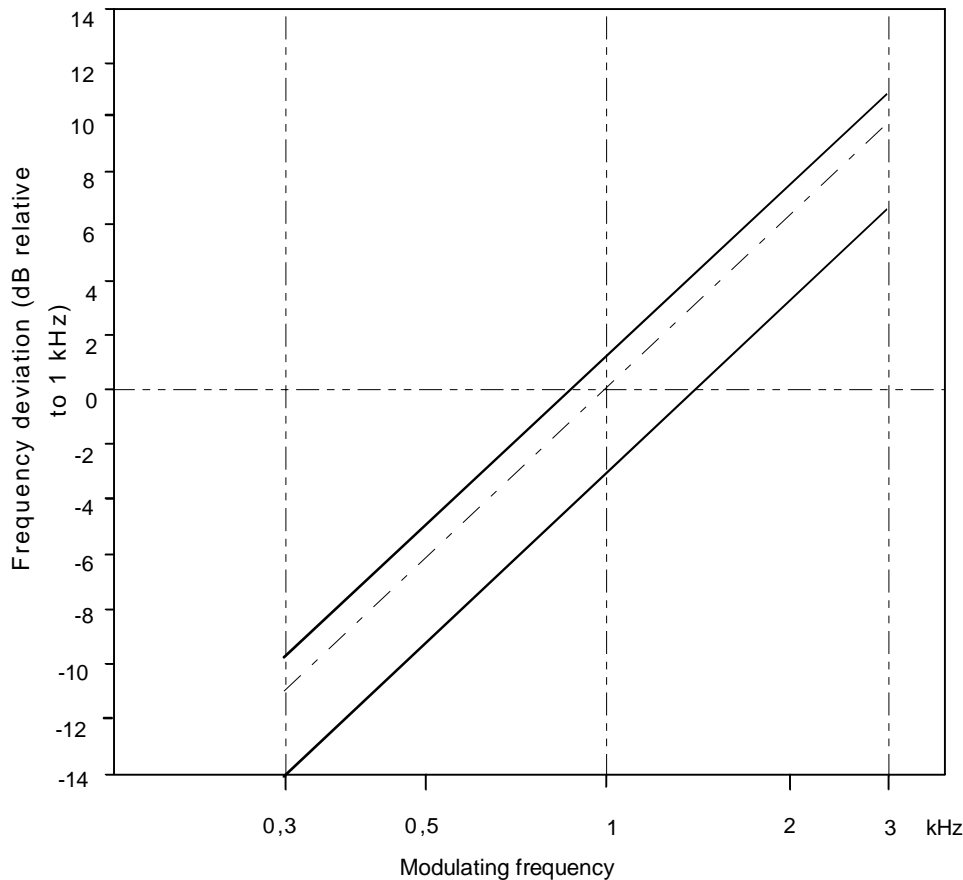

**Figure 4: Transmitter modulating frequency response limits**

## 13.7 Audio frequency harmonic distortion of the emission

### 13.7.1 Definition

Harmonic distortion of the emission, with the transmitter modulated by an audio tone, is a parameter of the recovered audio signal after linear demodulation of the transmitter output, and is defined as the percentage ratio of the rms voltage of all the harmonics (of the audio tone fundamental frequency) within the recovered audio signal to its total rms voltage.

### 13.7.2 Method of measurement

Arrangements for modulating the transmitter are specified in clause 7.8. Arrangements for monitoring the transmitter output are specified in clause 7.9.

Measurements shall be made with the output power set at maximum and also with the output power set at minimum.

This test shall be carried out under normal test conditions and under extreme test conditions, as specified in clauses 6.3 and 6.4 respectively.

Under normal test conditions the transmitter shall be modulated with audio tones at 300 Hz, 500 Hz and 1 kHz successively, with a constant modulation index of 3. The distortion of the audio frequency signal shall be measured in each case.

Under extreme test conditions the transmitter shall be modulated with an audio tone at 1 kHz, with a modulation index of 3. The distortion of the audio frequency signal shall be measured.

### 13.7.3 Limits

The harmonic distortion shall not exceed 10 %.

## 13.8 Adjacent channel power

### 13.8.1 Definition

The adjacent channel power is that part of the total power output of a transmitter, under defined conditions of modulation, which falls within a specified passband centred on the nominal frequency of either of the adjacent channels.

### 13.8.2 Method of measurement

Measurements shall be made on channel 16, and also on the highest frequency and lowest frequency channels.

The adjacent channel power shall be measured with a power measuring receiver which conforms to annex A, referred to in this clause and annex A as "the receiver" (see also ITU-R Recommendation SM.332-4 [11]):

- a) arrangements for coupling the transmitter RF output to the "receiver" are specified in clause 7.9;
- b) with the transmitter unmodulated, the tuning of the "receiver" shall be adjusted so that a maximum response is obtained. This is the 0 dB response point. The "receiver" attenuator setting and the reading of the meter shall be recorded;
- c) the measurement may be made with the transmitter modulated with normal test modulation, in which case this fact shall be recorded with the test results;
- d) the tuning of the "receiver" shall be adjusted away from the carrier so that the "receiver" -6 dB response nearest to the transmitter carrier frequency is located at a displacement from the nominal carrier frequency of 17 kHz;
- e) the transmitter shall be modulated with an audio tone at 1,25 kHz at a level 20 dB higher than that required to produce  $\pm 3$  kHz peak frequency deviation;
- f) the "receiver" variable attenuator shall be adjusted to obtain the same meter reading as in step b) or a known relation to it;
- g) the ratio of adjacent channel power to carrier power is the difference between the attenuator settings in steps b) and e), corrected for any differences in the reading of the meter;
- h) the measurement shall be repeated with the "receiver" tuned to the other side of the carrier.

### 13.8.3 Limits

The adjacent channel power shall be at least 70 dB below the carrier power of the transmitter but without any need to be below 0,2  $\mu$ W.

## 13.9 Residual modulation of the transmitter

### 13.9.1 Definition

The residual modulation of the transmitter is the ratio, in dB, of the demodulated RF signal in the absence of wanted modulation, to the demodulated RF signal produced when the normal test modulation is applied.

## 13.9.2 Method of measurement

Arrangements for modulating the transmitter are specified in clause 7.8. Arrangements for monitoring the transmitter output are specified in clause 7.9.

Precautions shall be taken to avoid the effects of emphasising the low audio frequencies produced by internal noise.

The transmitter shall be modulated with normal test modulation as specified in clause 7.8, and the recovered audio signal level shall be measured.

The modulation shall then be switched off and the recovered audio signal level shall be measured again.

## 13.9.3 Limit

The residual modulation shall not exceed -40 dB.

## 13.10 Modulator attack time

### 13.10.1 Definition

The modulator attack time is the time elapsed between keying the transmitter and the transmitter being correctly modulated.

### 13.10.2 Method of measurement

Arrangements for monitoring the transmitter output are shown in figure 5: the transmitter output is coupled by suitable means to a wideband test discriminator, and the DSC key line is used to trigger a storage oscilloscope connected to the output of the discriminator. The oscilloscope shows the modulation behaviour of the transmitter during the switch-on transient.

The test shall be performed on channel 70.

A continuous audio tone at 1 300 Hz and with a level of  $0,775 \text{ V} \pm 0,075 \text{ V}$  shall be applied to the transmitter DSC signal input port, and the transmitter shall be set to transmit using the DSC key lines.

A typical oscilloscope trace is shown in figure 6: the settling time  $t_{\text{set}}$  is the time elapsed from when the transmitter is keyed until the recovered audio remains constant in amplitude.

The test shall be repeated with the transmitter modulated by a 2 100 Hz tone of the same level.

### 13.10.3 Limit

The settling time  $t_{\text{set}}$  shall be less than 90 ms.

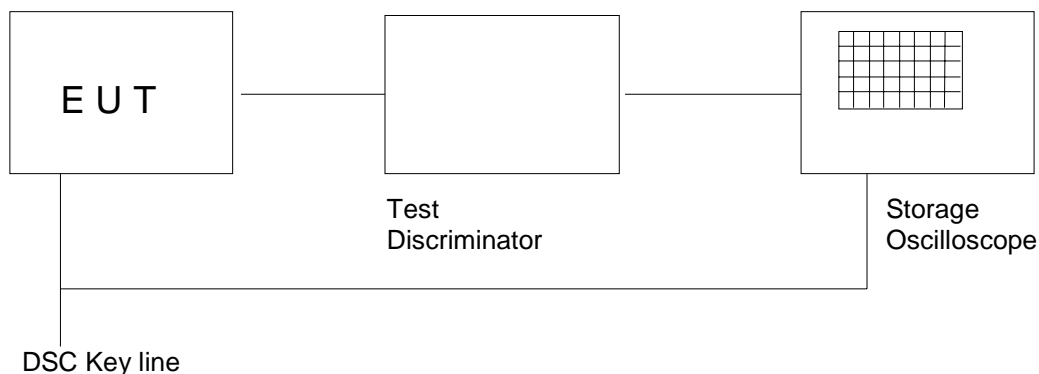

**Figure 5: Modulator attack time test configuration**

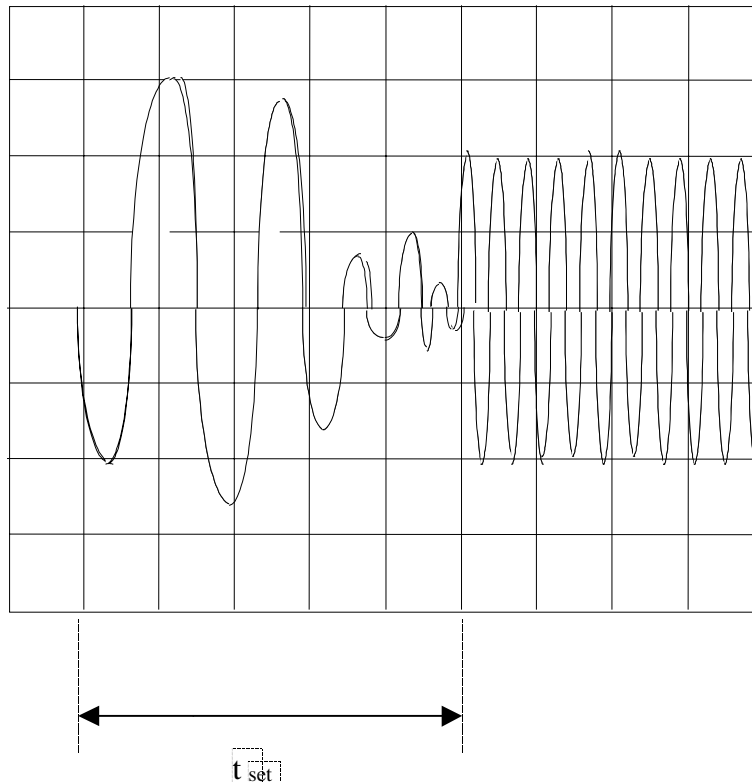

**Figure 6: Modulator attack time, typical oscilloscope trace**

## 13.11 Transient frequency behaviour of the transmitter

### 13.11.1 Definition

The transient frequency behaviour of the transmitter is the variation of the transmitter frequency from the nominal frequency, with time, when the RF output power is switched on and off.

### 13.11.2 Method of measurement

In order to define the method of measurement, the following definitions will apply:

- $t_{on}$  the switch-on instant, defined as the instant when the output power, measured at the transmitter antenna port, exceeds 0,1 % of the nominal power;
- $t_1$  the period of time starting at  $t_{on}$  and ending 5 ms later;
- $t_2$  the period of time starting at the end of  $t_1$  and ending 20 ms later;
- $t_{off}$  the switch-off instant, defined as the instant when the output power, measured at the transmitter antenna port, falls below 0,1 % of the nominal power;
- $t_3$  the period of time ending at  $t_{off}$  and starting 5 ms earlier.

Arrangements for monitoring the transmitter output are shown in figure 7: the transmitter output is connected via a 50  $\Omega$  power attenuator to the first input of a combining network, and a test signal generator is connected to the second input.

The output of the combining network is connected to the RF input of a test discriminator. The arrangements shall be such that all ports are presented with a 50  $\Omega$  non-reactive termination.

The output of the test discriminator, representing the difference between the instantaneous frequency of the combined input and the nominal frequency of the test channel (the frequency difference  $f_d$ ), is connected to a storage oscilloscope for display.

A signal corresponding to the amplitude of the combined RF input to the test discriminator (the amplitude difference  $a_d$ ) must be derived and connected to trigger the storage oscilloscope. Typically the storage oscilloscope is set to a sweep rate of 10 ms/division, and set to trigger at 1 division from the left edge of the display.

With the EUT transmitter inactive the test signal generator is set to the nominal frequency of the transmitter, and modulated with a 1 kHz tone to a peak deviation of  $\pm 25$  kHz. The level of the test signal is set to 30 dB below the level of the EUT transmitter in the combined signal. This level is then maintained throughout the measurement.

With the oscilloscope on free running trigger, adjustments can be made at this point to centre and calibrate the vertical scale in terms of frequency deviation, since the displayed 1 kHz sinewave of the demodulated test signal represents a peak-to-peak deviation of 50 kHz around the nominal channel frequency.

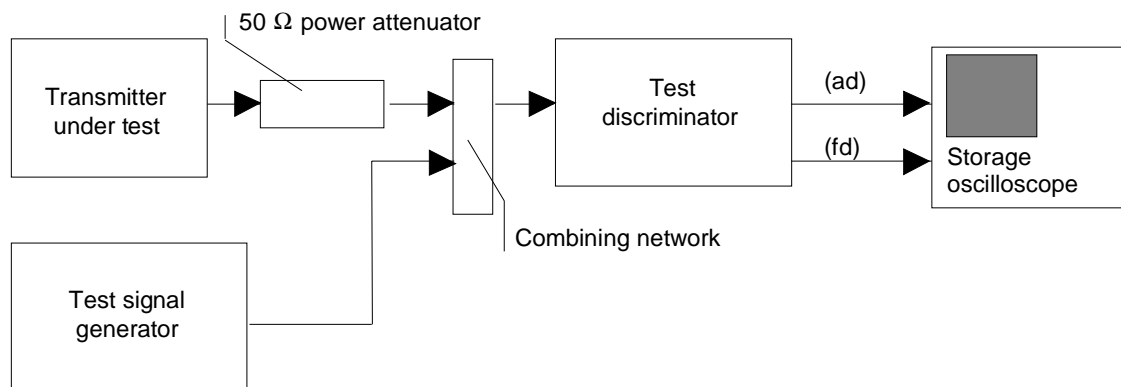

**Figure 7: Transient frequency behaviour test configuration**

With the above test configuration and calibration complete, the storage oscilloscope is set up to trigger on the  $a_d$  signal at a level slightly greater than that produced by the test signal.

The transmitter is then switched on, without modulation: as a result the oscilloscope will trigger and a trace will be captured on the display.

The rising power of the transmitter signal will capture the discriminator as its amplitude exceeds that of the test signal; the moment when this happens corresponds to  $t_{on}$  as defined above, and this moment is readily identifiable on the trace by the complete suppression of the 1 kHz sine wave of the demodulated test signal.

On the trace everything after  $t_{on}$  shows the frequency difference of the transmitter over time as it settles towards the nominal channel frequency:

The above procedure will capture the transmitter transient frequency behaviour at switch-on. To capture the transient frequency behaviour at switch-off the storage oscilloscope is set up to trigger on the decaying  $a_d$  signal at a level slightly less than that produced by the transmitter signal, and the transmitter is switched off.

The moment  $t_{off}$  as defined above is identified on the trace as the point at which the 1 kHz sine wave of the demodulated test signal begins to rise, signifying that the test signal has captured the discriminator as its amplitude exceeds that of the transmitter signal.

The transmitter transient frequency behaviour at switch-on and at switch-off, obtained as detailed above, shall be recorded. The test report shall include a graphical record of frequency difference versus time in each case.

### 13.11.3 Limits

During the periods  $t_1$  and  $t_3$  the frequency difference shall not exceed the value of 25 kHz.

During the period  $t_2$  the frequency difference shall not exceed the value of 12,5 kHz.

After period  $t_2$  and before period  $t_3$  the frequency difference shall be within the limits of the transmitter frequency error, as defined in clause 13.2.3.

The limits of transient frequency behaviour are shown graphically in figure 8.



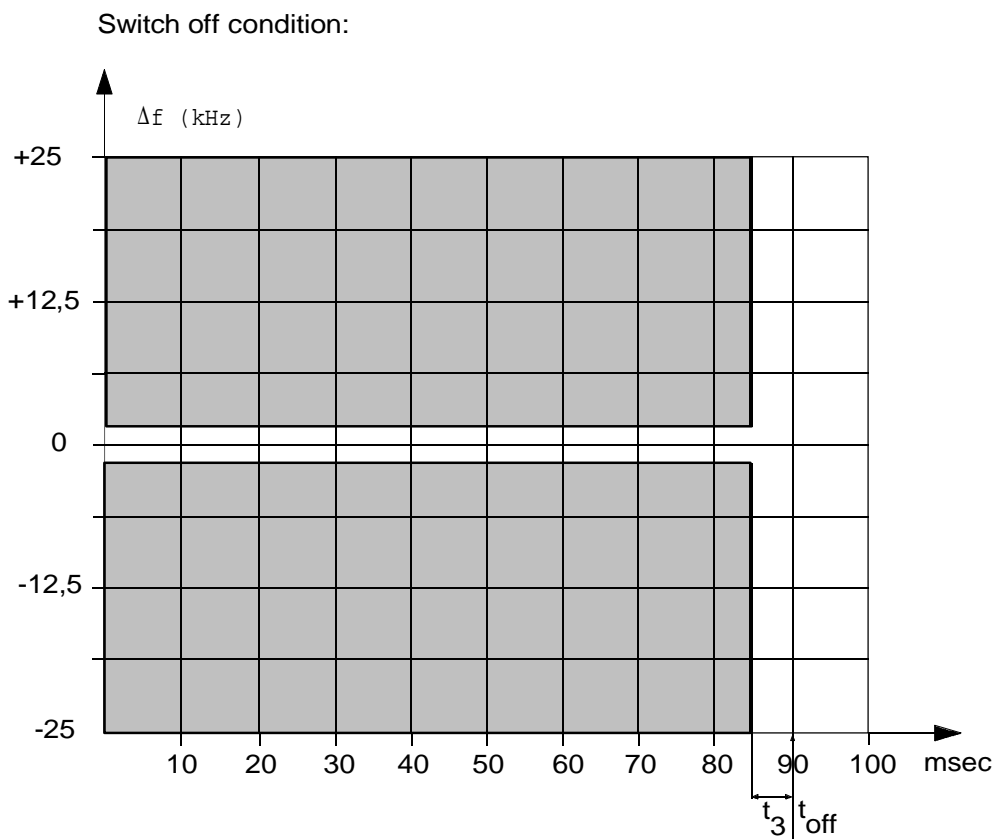
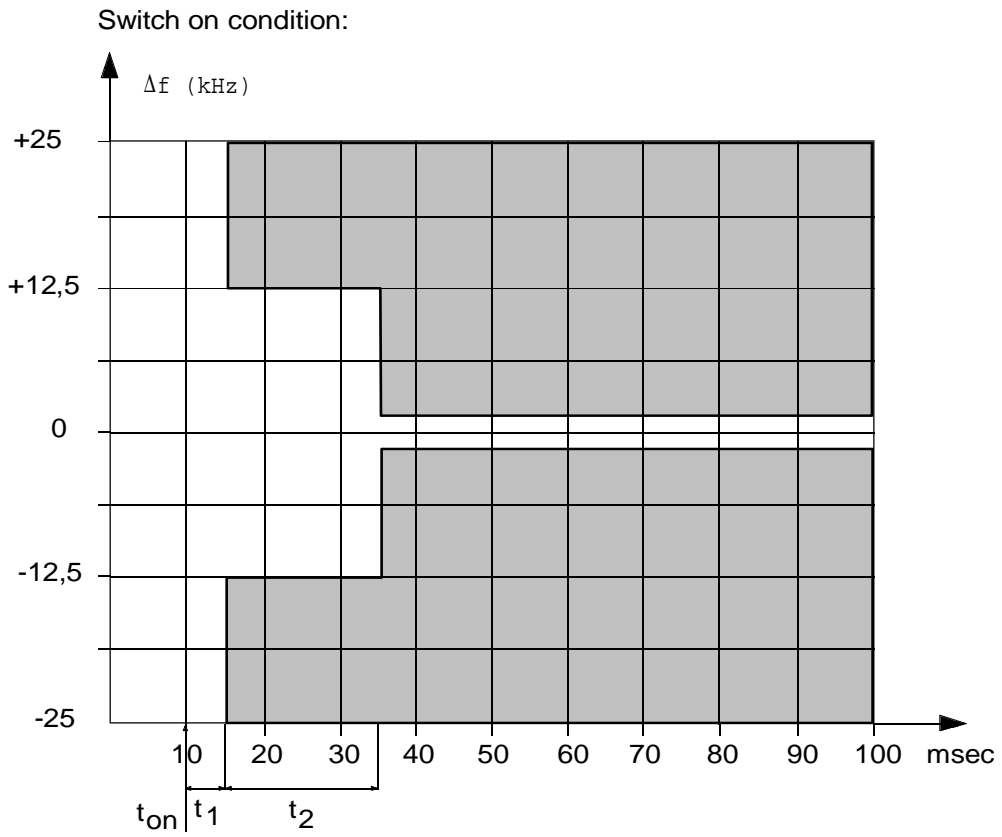

Figure 8: Transient frequency behaviour response masks

## 13.12 DSC audio input characteristics

### 13.12.1 Definition

This test verifies the ability of the transmitter to correctly modulate a DSC signal.

### 13.12.2 Method of measurement

The test shall be performed on channel 70.

The transmitter shall be set to transmit using the DSC key lines.

The transmitter shall be modulated via the DSC signal input port with a continuous audio tone at 1 300 Hz and with a level of  $0,775 \text{ V rms} \pm 0,075 \text{ V rms}$ .

The modulation index of the transmitter shall be measured.

The test shall be repeated with an audio tone at 2 100 Hz having the same amplitude.

### 13.12.3 Limits

The modulation index shall be between 1,8 and 2,2 in both cases.

## 13.13 DSC audio input limitation

### 13.13.1 Definition

This test verifies the ability of the transmitter to limit deviation in case of excessive DSC input signals.

### 13.13.2 Method of measurement

The test shall be performed on channel 70.

The transmitter shall be set to transmit using the DSC key lines.

The transmitter shall be modulated via the DSC signal input port with a continuous audio tone at 2 100 Hz and with a level of  $2,45 \text{ V rms} \pm 0,3 \text{ V rms}$ .

The modulation index of the transmitter shall be measured.

### 13.13.3 Limit

The modulation index shall be less than 2,4.

## 13.14 Testing of generated DSC call sequences

### 13.14.1 Definition

Generated call sequences are calls which comply with the requirements of ITU-R Recommendation M.493-10 [8].

## 13.14.2 Method of measurement

For the purposes of this test, if the equipment does not contain an integral DSC encoder, it shall be connected to an external DSC encoder as described in clause 7.10 via the interfaces specified in clause 5.4.

The output of the transmitter shall be suitably connected to a calibrated apparatus for decoding and printing out the information content of the call sequences generated by the equipment.

The transmitter shall be set to transmit, in turn, at least 5 DSC calls using different permutations of format specifier, category, 1<sup>st</sup> and 2<sup>nd</sup> telecommands and frequency information (as relevant to the class of DSC as declared by the manufacturer).

## 13.14.3 Requirement

The requirements of ITU-R Recommendation M.493-10 [8] regarding message composition and content shall be met.

The generated calls shall be analysed with the calibrated apparatus for correct configuration of the signal format, including time diversity.

It shall be verified that, after transmission of a DSC call, the transmitter re-tunes to the original channel.

The telecommands used and the channels tested for switching shall be stated in the test report.

---

# 14 Receiver

## 14.1 Harmonic distortion and rated audio output power

### 14.1.1 Definition

Harmonic distortion at the receiver output, in the presence of a wanted RF signal modulated by an audio tone, is defined as the percentage ratio of the rms voltage of all the harmonics (of the audio tone fundamental frequency) within the recovered audio signal to its total rms voltage.

Rated audio output power is the maximum power available at the output as declared by the manufacturer, for which all the requirements of the present document are met.

### 14.1.2 Methods of measurement

A wanted test signal at +100 dB $\mu$ V emf shall be applied to the receiver RF input port as specified in clause 7.4. The receiver audio output shall be monitored as specified in clause 7.6.

Under normal test conditions as specified in clause 6.3 the test signal shall be modulated with an audio tone at 300 Hz, 500 Hz and 1 kHz successively, with a modulation index of 3 in each case.

The receiver volume control shall be set to obtain the rated audio output power and the harmonic distortion and audio output power shall be measured in each case.

Under extreme test conditions as specified in clause 6.4, the test signal shall be modulated with an audio tone at 1 kHz and with a modulation index of 3. The carrier frequency of the wanted test signal shall be set to the receiver's nominal frequency and to the nominal frequency  $\pm 1,5$  kHz successively.

The receiver volume control shall be set to obtain the rated audio output power and the harmonic distortion and audio output power shall be measured in each case.

### 14.1.3 Limits

The rated audio output power shall be at least:

- 2 W in a loudspeaker;
- 1 mW in the handset earphone.

The harmonic distortion shall not exceed 10 %.

## 14.2 Audio frequency response

### 14.2.1 Definition

The audio frequency response is the variation in the receiver audio output level as a function of the modulating frequency of the radio frequency signal with constant deviation applied to its input.

### 14.2.2 Method of measurement

A wanted test signal at +60 dB $\mu$ V emf, modulated by the normal test modulation as specified in clause 7.5, shall be applied to the receiver RF input port as specified in clause 7.4. The receiver audio output shall be monitored as specified in clause 7.6.

The receiver volume control shall be set to produce at least 50 % of the rated audio output power. This setting shall remain unchanged during the test.

The test signal frequency deviation shall then be reduced to 1 kHz. The audio output level is the reference point in figure 9 (i.e. 1 kHz frequency deviation corresponds to 0 dB).

The frequency of the modulating tone shall then be varied between 300 Hz and 3 kHz while the frequency deviation is maintained constant. The audio output level shall be measured over this range.

Measurements shall be made with the carrier frequency of the wanted test signal set to the receiver's nominal frequency and to the nominal frequency  $\pm 1,5$  kHz successively.

### 14.2.3 Limits

The audio frequency response shall be within +1 dB and -3 dB of a 6 dB per octave line passing through the reference point, as shown in figure 9.

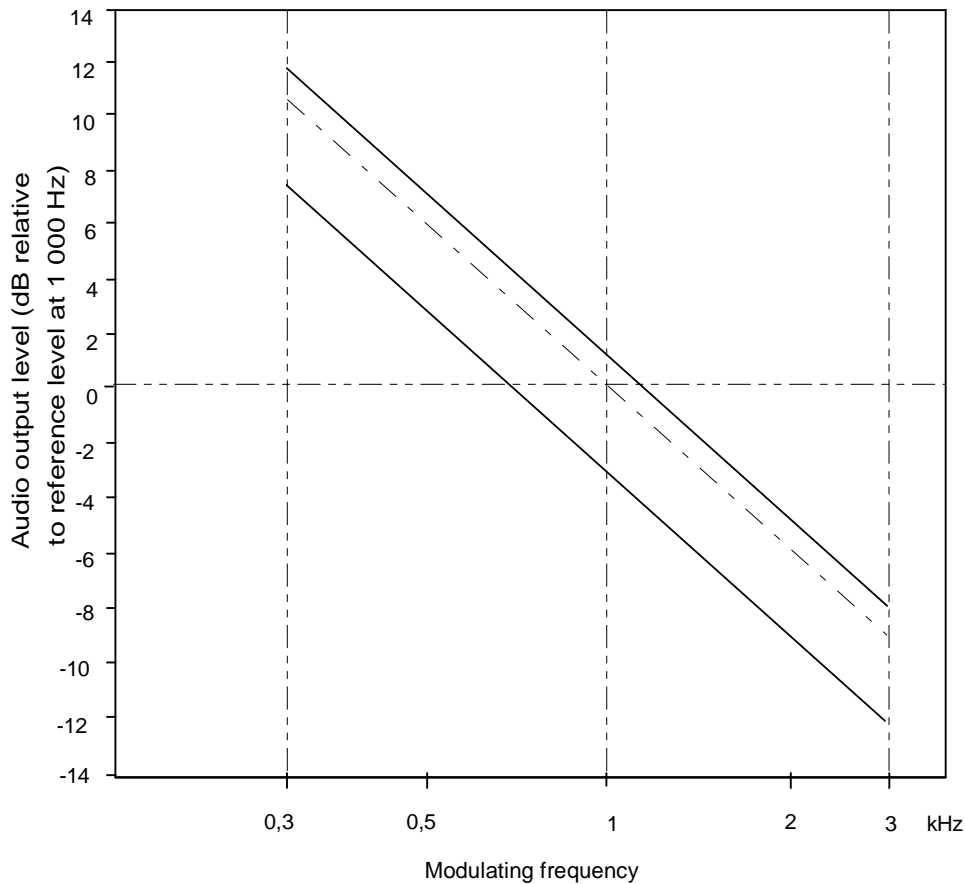

**Figure 9:Receiver audio frequency response limits**

## 14.3 Maximum usable sensitivity

### 14.3.1 Definition

The maximum usable sensitivity of the receiver is the minimum level of wanted RF signal, expressed in dB $\mu$ V emf, applied to the receiver input with normal test modulation, which will produce:

- an audio output power equal to 50 % of the rated audio output power; and
- a SINAD ratio of 20 dB, measured at the receiver output through a psophometric telephone filtering network such as described in ITU-T Recommendation O.41 [13].

### 14.3.2 Method of measurement

Measurements shall be made on channel 16, and also on the highest frequency and lowest frequency.

A test signal at a carrier frequency equal to the nominal frequency of the receiver, modulated by the normal test modulation as specified in clause 7.4 shall be applied to the receiver input. An audio frequency load and a measuring instrument for measuring the SINAD ratio through a psophometric network as specified in clause 7.6 shall be connected to the receiver output terminals.

The level of the test signal shall be adjusted until a SINAD ratio of 20 dB is obtained, using the psophometric network and with the receiver's audio frequency power control adjusted to produce 50 % of the rated output power. Under these conditions, the level of the test signal at the input is the value of the maximum usable sensitivity.

The measurements shall be made under normal test conditions as defined in clause 6.3 and under extreme test conditions as defined in clauses 6.4.1 and 6.4.2 applied simultaneously.

A receiver output power variation of  $\pm 3$  dB relative to 50 % of the rated output power may be allowed for sensitivity measurements under extreme test conditions.

### 14.3.3 Limits

The maximum usable sensitivity level shall not exceed +6 dB $\mu$ V emf under normal test conditions and +12 dB $\mu$ V emf under extreme test conditions.

## 14.4 Amplitude characteristic of the receiver

### 14.4.1 Definition

The amplitude characteristic of the receiver is the relationship between the RF level of a specified modulated signal at the receiver input and the resulting audio level at the receiver output.

### 14.4.2 Method of measurement

A wanted test signal at +6 dB $\mu$ V emf, modulated by the normal test modulation as specified in clause 7.5, shall be applied to the receiver RF input port as specified in clause 7.4. The receiver audio output shall be monitored as specified in clause 7.6.

The receiver volume control shall be set to produce at least 50 % of the rated audio output power. The audio output level shall be recorded.

The level of the wanted test signal shall be increased to 100 dB $\mu$ V emf and the audio output level shall again be recorded. The amplitude characteristic of the receiver is characterized by the ratio between the two recorded audio output levels, expressed in dB.

### 14.4.3 Limits

For the specified change in RF input signal level, the change of audio output level shall not exceed 3,0 dB.

## 14.5 Co-channel rejection

### 14.5.1 Definition

Co-channel rejection is a measure of the capability of the receiver to receive a wanted modulated signal without exceeding a given degradation due to the presence of an unwanted modulated signal, both signals being at the nominal frequency of the receiver.

### 14.5.2 Method of measurement

The outputs from two signal generators, A and B, shall be combined and shall be applied to the receiver RF input port as specified in clause 7.4.

From signal generator A, a wanted test signal, modulated by the normal test modulation as specified in clause 7.5, shall be applied to the receiver RF input port at the maximum usable sensitivity level as measured in clause 14.3.

From signal generator B an unwanted signal, modulated by 400 Hz with a deviation of  $\pm 3$  kHz, set to the nominal frequency of the receiver, shall be applied to the receiver RF input port at a low level.

The receiver audio output shall be monitored as specified in clause 7.6. The level of the unwanted signal shall be increased until the receiver output SINAD ratio falls to 14 dB.

The measurement shall be repeated for displacements of the unwanted signal over the range  $\pm 3$  kHz.

The co-channel rejection ratio is the dB ratio of the level of the unwanted signal to the level of the wanted signal at the receiver input for which the specified degradation in SINAD ratio occurs.

### 14.5.3 Limit

The co-channel rejection ratio, at any frequency of the unwanted signal within the specified range, shall be between -10 dB and 0 dB.

## 14.6 Adjacent channel selectivity

### 14.6.1 Definition

Adjacent channel selectivity is a measure of the ability of the receiver to receive a wanted modulated signal without exceeding a given degradation due to the presence of an unwanted modulated signal which differs in frequency from the wanted signal by 25 kHz.

### 14.6.2 Method of measurement

Measurements shall be made on channel 16, and also on the highest frequency and lowest frequency channels.

The outputs from two signal generators, A and B, shall be combined and shall be applied to the receiver RF input port as specified in clause 7.4.

From signal generator A, a wanted test signal, modulated by the normal test modulation as specified in clause 7.5, shall be applied to the receiver RF input port at the maximum usable sensitivity level as measured in clause 14.3.

From signal generator B, an unwanted signal, modulated by 400 Hz with a deviation of  $\pm 3$  kHz, set to the nominal frequency of the channel immediately above the test channel, shall be applied to the receiver RF input port at a low level.

The receiver audio output shall be monitored as specified in clause 7.6. The level of the unwanted signal shall be increased until the receiver output SINAD ratio falls to 14 dB.

The adjacent channel selectivity is the dB ratio of the level of the unwanted signal to the level of the wanted signal.

The measurement shall be repeated with an unwanted signal at the nominal frequency of the channel immediately below the test channel.

This test shall be carried out under normal test conditions and under extreme test conditions, as specified in clauses 6.3 and 6.4 respectively. Under extreme test conditions the wanted signal level shall be the maximum usable sensitivity level measured under extreme test conditions.

### 14.6.3 Limits

The adjacent channel selectivity shall be not less than 70 dB under normal test conditions and not less than 60 dB under extreme test conditions.

## 14.7 Spurious response rejection

### 14.7.1 Definition

Spurious response rejection is a measure of the ability of the receiver to discriminate between the wanted modulated signal at the nominal frequency and an unwanted signal at any other frequency at which a response is obtained.

## 14.7.2 Method of measurement

### 14.7.2.1 Introduction to the method of measurement

To determine the frequencies at which spurious responses can occur the following calculations shall be made:

a) calculation of the "limited frequency range".

- The "limited frequency range" is equal to:

the frequency of the local oscillator signal ( $f_{lo}$ ) applied to the 1st mixer of the receiver  $\pm$  the sum of the intermediate frequencies ( $fIF_1, \dots, fIF_n$ ) and a half the switching range ( $sr$ ) of the receiver.

- Hence:

the "limited frequency range" =  $f_{lo} \pm (fIF_1 + fIF_2 + \dots + fIF_n + sr/2)$ .

b) calculation of frequencies outside the "limited frequency range".

- A calculation of the frequencies at which spurious responses can occur outside the range determined in (a) is made for the remainder of the frequency range of interest, as appropriate, clause 14.7.2.3.

- The frequencies outside the "limited frequency range" are equal to:

the harmonics of the frequency of the local oscillator signal ( $f_{lo}$ ) applied to the 1st mixer of the receiver  $\pm$  the numeric value of the 1st intermediate frequency ( $fIF_1$ ) of the receiver.

- Hence:

the frequencies of these spurious responses =  $nf_{lo} \pm fIF_1$  where 'n' is an integer greater than or equal to 2.

For the calculations (a) and (b) above the manufacturer shall state the frequency of the receiver, the frequency of the local oscillator signal ( $f_{lo}$ ) applied to the 1st mixer of the receiver, the intermediate frequencies ( $fIF_1, fIF_2$  etc.) and the switching range ( $sr$ ) of the receiver.

### 14.7.2.2 Method of search over the "limited frequency range"

The two input signals shall be connected to the receiver via a combining network, clause 7.4.

The wanted test signal, at the nominal frequency of the receiver, with normal test modulation, clause 7.5, at the measured maximum useable sensitivity, shall be applied to the receiver input connector via one input of the combining network.

The unwanted test signal, modulated with a frequency of 400 Hz at a deviation of  $\pm 5$  kHz, at an emf of 86 dB $\mu$ V, shall be applied to the receiver input connector via the second input of the combining network.

The frequency of the unwanted signal shall be varied incrementally over the "limited frequency range".

The incremental steps of the frequency of the unwanted signal shall be 5 kHz.

The frequency of any spurious response detected during the search shall be recorded for the use in measurements in accordance with clause 14.7.2.3.



### 14.7.2.3 Method of measurement

The two input signals shall be connected to the receiver via a combining network, clause 7.4.

The wanted test signal, at the nominal frequency of the receiver, with normal test modulation, clause 7.5, at the measured maximum useable sensitivity shall be applied to the receiver input connector via one input of the combining network.

The unwanted test signal, modulated with a frequency of 400 Hz at a deviation of 60 % of the maximum permissible frequency deviation of 5kHz, at an emf of 86 dB $\mu$ V, shall be applied to the receiver input connector via the second input of the combining network.

The measurement shall be performed at all spurious response frequencies found during the search over the "limited frequency range", clause 14.7.2.2, and at frequencies calculated for the remainder of the spurious response frequencies in the frequency range 100 kHz to 2 GHz.

At each frequency at which a spurious response occurs, the input level shall be adjusted until the SINAD ratio, psophometrically weighted, is reduced to 14 dB.

The measure of the spurious response rejection is the ratio in dB of the level of the unwanted test signal to the level of the wanted test signal at the receiver input for which the specified reduction in SINAD ratio occurs.

The ratio shall be recorded as the spurious response rejection for each spurious response obtained.

### 14.7.3 Limit

At any frequency separated from the nominal frequency of the receiver by more than 25 kHz, the spurious response rejection ratio shall be not less than 70 dB.

## 14.8 Intermodulation response

### 14.8.1 Definition

Intermodulation response is a measure of the ability of the receiver to receive a wanted modulated signal without exceeding a given degradation due to the presence of two or more unwanted signals with a specific frequency relationship to the wanted signal frequency.

### 14.8.2 Method of measurement

Three signal generators, A, B and C shall be connected to the receiver via a combining network as specified in clause 7.4. The wanted signal, represented by signal generator A shall be at the nominal frequency of the receiver and shall have normal test modulation as specified in clause 7.5. The unwanted signal from signal generator B shall be unmodulated and adjusted to the frequency 50 kHz above (or below) the nominal frequency of the receiver. The second unwanted signal from signal generator C shall be modulated by 400 Hz with a deviation of  $\pm 3$  kHz, and adjusted to a frequency 100 kHz above (or below) the nominal frequency of the receiver.

The wanted input signal shall be set to a value corresponding to the maximum usable sensitivity as measured in clause 14.3. The amplitude of the two unwanted signals shall be maintained equal and shall be adjusted until the SINAD ratio at the receiver output, psophometrically weighted, is reduced to 14 dB. The frequency of signal generator B shall be adjusted slightly to produce the maximum degradation of the SINAD ratio. The level of the two unwanted test signals shall be readjusted to restore the SINAD ratio of 14 dB. The intermodulation response ratio shall be expressed as the ratio in dB between the two unwanted signals and the wanted signal at the receiver input, when the specified reduction in the SINAD ratio is obtained.

### 14.8.3 Limit

The intermodulation response ratio shall not be less than 70 dB.

## 14.9 Blocking or desensitisation

### 14.9.1 Definition

Blocking is a change (generally a reduction) in the output power of the receiver or a reduction of the SINAD ratio due to a high level unwanted signal on another frequency.

### 14.9.2 Method of measurement

The outputs from two signal generators, A and B, shall be combined and shall be applied to the receiver RF input port as specified in clause 7.4.

From signal generator A, a wanted test signal, modulated by the normal test modulation as specified in clause 7.5, shall be applied to the receiver RF input port at the maximum usable sensitivity level as measured in clause 14.3.

The receiver volume control shall be set to produce at least 50 % of the rated audio output power.

Initially the unwanted signal shall be switched off.

From signal generator B, an unwanted signal shall be applied to the receiver RF input port at frequencies of  $\pm 1$  MHz,  $\pm 2$  MHz,  $\pm 5$  MHz, and  $\pm 10$  MHz relative to the nominal frequency of the receiver. The unwanted signal shall be unmodulated. The input level of the unwanted signal, at all the specified frequencies, shall be adjusted so as to cause:

- a) a reduction of 3 dB in the output level of the wanted signal; or
- b) a reduction of the SINAD ratio at the receiver output to 14 dB; whichever occurs first.

The blocking level in each case is the level of the unwanted signal as adjusted above.

### 14.9.3 Limit

The blocking level for any of the specified frequencies shall be not less than 90 dB $\mu$ V emf, except at frequencies on which spurious responses are found as specified in clause 14.7.

## 14.10 Receiver noise and hum level

### 14.10.1 Definition

The receiver noise and hum level is defined as the dB ratio of the audio power of noise and hum resulting from spurious effects of the power supply system or from other causes, to the audio power produced from a wanted signal with normal test modulation applied to the receiver input.

### 14.10.2 Method of measurement

A wanted test signal at +30 dB $\mu$ V emf, modulated by the normal test modulation as specified in clause 7.5, shall be applied to the receiver RF input port as specified in clause 7.4. The receiver audio output shall be monitored as specified in clause 7.6.

The receiver volume control shall be set to produce the rated audio output power.

The audio output level shall be measured. The modulation shall then be switched off and the output level measured again.

### 14.10.3 Limit

The receiver noise and hum level shall not exceed -40 dB, relative to the modulated signal.

## 14.11 Squelch operation

### 14.11.1 Description

The purpose of the squelch facility is to mute the receiver audio output in the absence of a valid RF signal at the receiver input. The squelch control may be on/off or continuously variable.

### 14.11.2 Squelch audio muting

#### 14.11.2.1 Definition

The effectiveness of the muting of the receiver is characterized by measuring the receiver audio output in the absence of an input signal, relative to the rated audio output power as defined in clause 14.1.1.

#### 14.11.2.2 Method of measurement

A wanted test signal at +30 dB $\mu$ V emf, modulated by the normal test modulation as specified in clause 7.5, shall be applied to the receiver RF input port as specified in clause 7.4. The receiver audio output shall be monitored as specified in clause 7.6.

The receiver volume control shall be set to produce at least 50 % of the rated audio output power. The wanted test signal shall then be suppressed, the squelch facility shall be switched on, and the receiver audio output level shall be measured.

#### 14.11.2.3 Limits

The muted audio output power of the receiver shall not exceed -40 dB relative to the rated audio output power.

### 14.11.3 Squelch operating level

#### 14.11.3.1 Definition

The squelch must always open when a certain minimum level of wanted signal is presented to the receiver RF input port.

#### 14.11.3.2 Method of measurement

A wanted test signal at +6 dB $\mu$ V emf, modulated by the normal test modulation as specified in clause 7.5, shall be applied to the receiver RF input port as specified in clause 7.4. The receiver audio output shall be monitored as specified in clause 7.6. The receiver volume control shall be set to produce at least 50 % of the rated audio output power.

The wanted test signal shall then be reduced by 20 dB, and the squelch facility shall be switched on (in the case of a continuously variable squelch control this should be set to maximum) so that the receiver audio output is muted. The wanted test signal level shall then be gradually increased until the squelch opens and the receiver audio output is restored to 50 % of the rated audio output power.

#### 14.11.3.3 Limits

The wanted test signal level required to restore the audio output shall not exceed +6 dB $\mu$ V emf. The SINAD ratio shall be not less than 20 dB.

## 14.11.4 Squelch hysteresis

### 14.11.4.1 Definition

Squelch hysteresis is the difference between the receiver input signal level at which the squelch opens and the level at which it closes, expressed in dB.

### 14.11.4.2 Method of measurement

A wanted test signal at  $-14\text{ dB}\mu\text{V}$  emf, modulated by the normal test modulation as specified in clause 7.5, shall be applied to the receiver RF input port as specified in clause 7.4. The receiver audio output shall be monitored as specified in clause 7.6.

The squelch facility shall be switched on (in the case of a continuously variable squelch control this should be set to maximum) so that the receiver audio output is muted. The wanted test signal level shall then be gradually increased until the squelch opens. This level shall be recorded. The wanted test signal level shall then be gradually decreased until the squelch closes again and mutes the receiver audio output. This level shall also be recorded. The squelch hysteresis is the difference between the two recorded wanted test signal levels.

### 14.11.4.3 Limit

The squelch hysteresis shall be between 3 dB and 6 dB.

## 14.12 Multiple watch characteristics

### 14.12.1 Definitions

The scanning period is the time between the start of two successive samples of the priority channel in the absence of a signal on that channel.

The dwell time on the priority channel is the time between the start and finish of any sample of the priority channel in the absence of a signal on that channel.

The dwell time on the additional channel is the time between the start and finish of any sample of the additional channel.

### 14.12.2 Method of measurement

Scan facilities shall not be available on channel 70. The equipment shall be adjusted to scan the priority channel and one additional channel. The squelch shall be operational and so adjusted that the receiver just mutes on both channels.

The outputs from two signal generators, A and B, shall be combined and shall be applied to the receiver RF input port as specified in clause 7.4.

From signal generator A, a wanted test signal on the additional channel, modulated by the normal test modulation as specified in clause 7.5, shall be applied to the receiver RF input port at  $+12\text{ dB}\mu\text{V}$  emf.

From signal generator B, a wanted test signal on the priority channel, unmodulated, shall be applied to the receiver RF input port at  $+12\text{ dB}\mu\text{V}$  emf. Initially signal generator B output shall be switched off.

A storage oscilloscope shall be connected to the receiver audio output, set to trigger with the rise of signal generator B output on the priority channel. The scanning process shall be started and the output observed on the oscilloscope. The gap between the audio bursts and the duration of the audio bursts shall be measured. Signal generator B output on the priority channel shall then be switched on: the scanning must stop on the priority channel at the next scan.

The measurement shall be performed with a simplex additional channel, and also with a duplex additional channel.

### 14.12.3 Limits

The scanning period shall not exceed 2 s.

The dwell time on the priority channel shall not exceed 150 ms.

The dwell time on the additional channel shall be between 850 ms and 2 s as indicated by the duration of the output bursts.

## 14.13 DSC audio output characteristic

### 14.13.1 Definition

DSC audio output characteristic is the level at the DSC output port, for the two DSC tones, when the receiver is receiving a correctly modulated DSC signal.

### 14.13.2 Methods of measurement

The test shall be performed on channel 70. A wanted test signal at +26 dB $\mu$ V emf, modulated by a 1 300 Hz tone with a modulation index of 2, shall be applied to the receiver RF input port as specified in clause 7.4. The receiver DSC output port shall be terminated in a 600  $\Omega$  load and the output level shall be measured.

The test shall be repeated with the wanted signal modulated by a 2 100 Hz tone, maintaining the modulation index of 2.

### 14.13.3 Limit

The level across the load on the DSC output port shall be between 0,55 V rms and 1,1 V rms.

## 14.14 DSC maximum usable sensitivity

### 14.14.1 Definition

The test verifies the ability of the receiver to receive a minimum level of wanted RF signal, expressed in dB $\mu$ V emf, applied to the receiver input and modulated with standard DSC test signals as specified in clause 7.11, with a symbol error ratio of  $10^{-2}$  or better.

### 14.14.2 Method of measurement

The test shall be performed on channel 70. A wanted test signal at a level of 0 dB $\mu$ V emf, modulated by standard DSC test signals as specified in clause 7.11, shall be applied to the receiver RF input port as specified in clause 7.4. The receiver DSC output port shall be monitored as specified in clauses 7.6 and 7.10.

The symbol error ratio in the decoder output shall be determined as described in clause 7.12.

The measurement shall be repeated under extreme test conditions, as specified in clause 6.4, with a wanted signal input level of +6 dB $\mu$ V emf.

The measurement shall be repeated under normal test conditions at the nominal carrier frequency offset by  $\pm 1,5$  kHz.

### 14.14.3 Limits

The symbol error ratio shall be not greater than  $10^{-2}$ .

## 14.15 DSC co-channel rejection

### 14.15.1 Definition

This test verifies the ability of the receiver to receive a wanted modulated signal without exceeding a given degradation due to the presence of an unwanted modulated signal, both signals being at the nominal frequency of the receiver.

### 14.15.2 Method of measurement

The outputs from two signal generators, A and B, shall be combined and shall be applied to the receiver RF input port as specified in clause 7.4.

From signal generator A, a wanted test signal, modulated by standard DSC test signals as specified in clause 7.11, shall be applied to the receiver RF input port at a level of +3 dB $\mu$ V emf.

From signal generator B, an unwanted signal, modulated by 400 Hz with a deviation of  $\pm 3$  kHz, set to the nominal frequency of the receiver, shall be applied to the receiver RF input port at a level of -5 dB $\mu$ V emf.

The receiver DSC output port shall be monitored as specified in clauses 7.6 and 7.10. The symbol error ratio in the decoder output shall be determined as described in clause 7.12.

The measurement shall be repeated for displacements of the unwanted signal over the range  $\pm 3$  kHz.

### 14.15.3 Limits

The symbol error ratio shall be not greater than  $10^{-2}$ .

## 14.16 DSC Adjacent channel selectivity

### 14.16.1 Definition

This test verifies the ability of the receiver to receive a wanted modulated signal without exceeding a given degradation due to the presence of an unwanted modulated signal which differs in frequency from the wanted signal by 25 kHz.

### 14.16.2 Method of measurement

The outputs from two signal generators, A and B, shall be combined and shall be applied to the receiver RF input port as specified in clause 7.4.

From signal generator A, a wanted test signal, modulated by standard DSC test signals as specified in clause 7.11, shall be applied to the receiver RF input port at a level of +3 dB $\mu$ V emf.

From signal generator B, an unwanted signal, modulated by 400 Hz with a deviation of  $\pm 3$  kHz, set to the nominal frequency of the channel immediately above the test channel, shall be applied to the receiver RF input port at a level of +73 dB $\mu$ V emf.

The receiver DSC output port shall be monitored as specified in clauses 7.6 and 7.10. The symbol error ratio in the decoder output shall be determined as described in clause 7.12.

The measurement shall be repeated with an unwanted signal at the nominal frequency of the channel immediately below the test channel.

This test shall be carried out under normal test conditions and under extreme test conditions, as specified in clauses 6.3 and 6.4 respectively. Under extreme test conditions the level of the wanted signal at the receiver RF input port shall be +9 dB $\mu$ V emf and the level of the unwanted signal at the receiver RF input port shall be +63 dB $\mu$ V emf.

### 14.16.3 Limits

The symbol error ratio shall be not greater than  $10^{-2}$ .

## 14.17 DSC dynamic range

### 14.17.1 Definition

The dynamic range of the equipment is the range from the minimum to the maximum level of input signal for which the symbol error ratio in the output of the decoder does not exceed a specified value.

### 14.17.2 Method of measurement

The test shall be performed on channel 70. A wanted test signal, modulated by standard DSC test signals as specified in clause 7.11, shall be applied to the receiver RF input port as specified in clause 7.4. The receiver DSC output port shall be monitored as specified in clauses 7.6 and 7.10.

The symbol error ratio in the decoder output shall be determined as described in clause 7.12.

The level of the wanted test signal shall be alternated between +100 dB $\mu$ V emf and 0 dB $\mu$ V emf.

### 14.17.3 Limit

The symbol error ratio shall be not greater than  $10^{-2}$ .

## 14.18 DSC intermodulation response

### 14.18.1 Definition

The intermodulation response is a measure of the capability of the receiver to receive a wanted modulated signal without exceeding a given degradation due to the presence of two or more unwanted signals with a specific frequency relationship to the wanted signal frequency.

### 14.18.2 Method of measurement

The three input signals shall be connected to the receiver input terminal via a combining network (see clause 7.4).

The wanted signal represented by signal generator A shall be at the nominal frequency of the receiver and shall be the DSC standard test signal (see clause 7.11) containing DSC calls. The level of the wanted signal shall be +3 dB $\mu$ V.

The unwanted signals shall be applied, both at the same level. The unwanted signal from signal generator B shall be unmodulated and adjusted to a frequency 50 kHz above (or below) the nominal frequency of the receiver. The second unwanted signal from signal generator C shall be modulated by 400 Hz with a deviation of  $\pm 3$  kHz and adjusted to a frequency 100 kHz above (or below) the nominal frequency of the receiver.

The input level of the unwanted signals shall be 73 dB $\mu$ V.

The bit error ratio in the decoder output shall be determined as described in clause 7.12.

### 14.18.3 Limits

The bit error ratio shall be equal to or less than  $10^{-2}$ .

## 14.19 Verification of correct decoding of various types of DSC calls

### 14.19.1 Definition

DSC call sequences are calls that comply with ITU-R Recommendation M.493-10 [8].

## 14.19.2 Method of measurement

For the purposes of this test, if the equipment does not contain an integral DSC decoder, it shall be connected to an external DSC decoder as described in clause 7.10 via the interfaces specified in clause 5.4.

The input terminal of the receiver shall be suitably connected to a calibrated apparatus for generation of digital selective call signals.

At least 5 DSC calls using different permutations of format specifier, category, 1<sup>st</sup> and 2<sup>nd</sup> telecommands and frequency information (as relevant to the class of DSC as declared by the manufacturer) shall be applied to the receiver.

## 14.19.3 Requirement

The requirements of ITU-R Recommendation M.493-10 [8] regarding message composition and content shall be met.

The decoded call sequences at the output of the decoder shall be examined for correct technical format, including error-check characters.

When decoder measurements are made by use of a printer or a computer, a check shall be made to ensure accordance between printer output and display indication.

It shall be verified that the equipment is capable of switching to a channel identified in the DSC call.

The telecommands used and channels tested for switching shall be stated in the test report.

---

# 15 Duplex operation

## 15.1 Introduction

If the equipment is designed for duplex operation, when submitted for conformance testing it shall be fitted with a duplex filter and the following additional measurements shall be carried out to ensure satisfactory duplex operation.

## 15.2 Receiver desensitisation with simultaneous transmission and reception

### 15.2.1 Definition

The desensitisation is the degradation of the sensitivity of the receiver resulting from the transfer of power from the transmitter to the receiver due to coupling effects.

It is expressed as the difference in dB of the maximum usable sensitivity levels with simultaneous transmission and without.

### 15.2.2 Method of measurement

The antenna terminal of the equipment comprising the receiver, transmitter and duplex filter shall be connected to appropriate test equipment as specified in clauses 7.4 and 7.9.

A signal generator with normal test modulation (see clause 7.5) shall be connected via a coupling device so that it does not affect the impedance matching.

The transmitter shall be brought into operation with the output power set at maximum, modulated by 400 Hz with a deviation of  $\pm 3$  kHz:

- the receiver sensitivity shall then be measured in accordance with clause 14.3;
- the output level of the signal generator shall be recorded as C in dB $\mu$ V emf;



- the transmitter shall be switched off and the receiver sensitivity is again measured;
- the output level of the signal generator shall be recorded as D in dB $\mu$ V emf;
- the desensitisation is the difference between the values of C and D.

### 15.2.3 Limits

The desensitisation shall not exceed 3 dB. The maximum usable sensitivity under conditions of simultaneous transmission and reception shall not exceed the limits specified in clause 14.3.

## 15.3 Duplex transceiver internal mixing

### 15.3.1 Definition

The duplex transceiver internal mixing will result in an unwanted receiver sensitivity at certain frequencies.

### 15.3.2 Method of measurement

The antenna terminal of the equipment comprising the receiver, transmitter and duplex filter shall be connected to appropriate test equipment as specified in clauses 7.4 and 7.9.

A test port enabling signal to be converted to the receiver shall be provided.

The equipment shall be tuned to channel 18 and the transmitter be brought in to unmodulated operation with the output power set at maximum.

The test defined in clause 14.7 using the test port as the receiver port shall be performed. Notwithstanding the frequency mentioned in clause 14.7, the test shall only be performed in the following bands:

- $\{161,5 - (2 \times \text{fIF}) - 1\}$  MHz to  $\{161,5 - (2 \times \text{fIF}) + 1\}$  MHz
- $\{161,5 + (2 \times \text{fIF}) - 1\}$  MHz to  $\{161,5 + (2 \times \text{fIF}) + 1\}$  MHz
- $\{156,9 + \text{fIF} - 1\}$  MHz to  $\{156,9 + \text{fIF} + 1\}$  MHz
- $\{156,9 - \text{fIF} - 1\}$  MHz to  $\{156,9 - \text{fIF} + 1\}$  MHz
- $\{156,9 - 4,6 - 1\}$  MHz to  $\{156,9 + 4,6 + 1\}$  MHz

where fIF is the first intermediate frequency of the receiver, to be stated by the manufacturer.

### 15.3.3 Limits

At any frequency at which a response is detected, the ratio defined in clause 14.7 shall be not less than 70 dB.

## Annex A (normative): Measuring receiver for adjacent channel power measurement

### A.1 General description of power measuring receiver

The power measuring receiver consists of a mixer, an IF filter, and oscillator, an amplifier, a variable attenuator and an rms value indicator. Instead of the variable attenuator with the rms value indicator it is also possible to use an rms voltmeter calibrated in dB. The technical characteristics of the power measuring receiver are given below. See also ITU-R Recommendation SM.332-4 [11].

### A.2 IF filter

The IF filter shall be within the limits of the following selectivity characteristic.

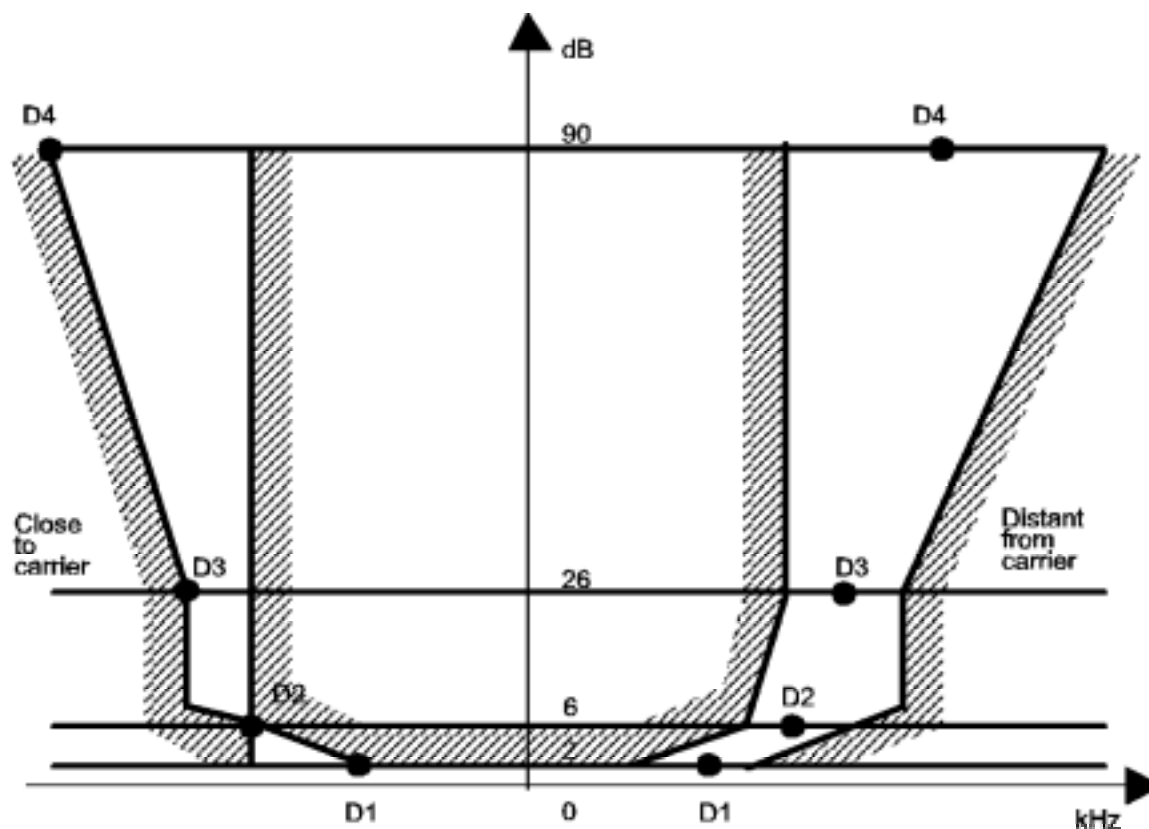

Figure A.1: IF Filter selectivity characteristic

The selectivity characteristic shall keep the frequency separations shown in table A.1 from the nominal centre frequency of the adjacent channel.

Table A.1: Selectivity characteristic

Frequency separation of filter curve from nominal centre frequency of adjacent channel (kHz)			
D1	D2	D3	D4
5	8,0	9,25	13,25

The attenuation points shall not exceed following tolerances shown in tables A.2 and A.3.

**Table A.2: Attenuation points close to carrier**

Tolerance range (kHz)			
D1	D2	D3	D4
+3,1	±0,1	-1,35	-5,35

**Table A.3: Attenuation points distant from the carrier**

Tolerance range (kHz)			
D1	D2	D3	D4
±3,5	±3,5	±3,5	+3,5 -7,5

The minimum attenuation of the filter outside the 90 dB attenuation points shall be equal to or greater than 90 dB.

---

## A.3 Attenuation indicator

The attenuation indicator shall have a minimum range of 80 dB and a reading accuracy of 1 dB. With a view to future regulations the attenuation should be 90 dB or more.

---

## A.4 RMS value indicator

The instrument shall accurately indicate non-sinusoidal signals in a ratio of up to 10 : 1 between peak value and rms value.

---

## A.5 Oscillator and amplifier

The oscillator and the amplifier shall be designed in such a way that the measurement of the adjacent channel power of a low-noise unmodulated transmitter, whose self-noise has a negligible influence on the measurement result, yields a measured value of < -90 dB.



## Annex C (normative): Radiated measurements

### C.1 Test sites and general arrangements for measurements involving the use of radiated fields

#### C.1.1 Outdoor test site

The outdoor test site shall be on a reasonably level surface or ground. At one point on the site, a ground plane of at least 5 m diameter shall be provided. In the middle of this ground plane, a non-conducting support, capable of rotation through 360° in the horizontal plane, shall be used to support the test sample at 1,5 m above the ground plane. The test site shall be large enough to allow the erection of a measuring or transmitting antenna at a distance of  $\lambda/2$  or 3 m whichever is the greater. The distance actually used shall be recorded with the results of the tests carried out on the site.

Sufficient precautions shall be taken to ensure that reflections from extraneous objects adjacent to the site and ground reflections do not degrade the measurements results.

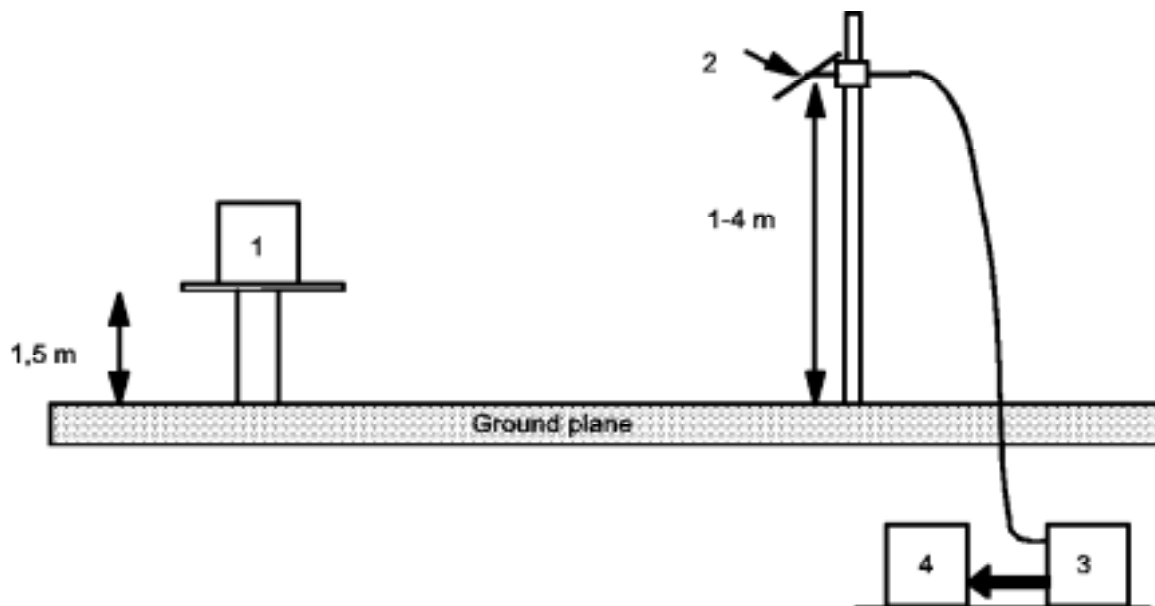

Key:

- 1: Equipment under test;
- 2: Test antenna;
- 3: High pass filter (necessary for strong fundamental Tx radiation);
- 4: Spectrum analyser or measuring receiver.

**Figure C.1: Outdoor test site**

## C.1.2 Test antenna

The test antenna is used to detect the radiation from both the test sample and the substitution antenna, when the site is used for radiation measurements; where necessary, it is used as a transmitting antenna, when the site is used for the measurement of receiver characteristics.

This antenna is mounted on a support such as to allow the antenna to be used in either horizontal or vertical polarization and for the height of its centre above ground to be varied over the range 1m to 4 m. Preferably a test antenna with pronounced directivity should be used. The size of the test antenna along the measurement axis shall not exceed 20 % of the measuring distance.

For receiver and transmitter radiation measurements, the test antenna is connected to a measuring receiver, capable of being tuned to any frequency under investigation and of measuring accurately the relative levels of signals at its input. For receiver radiated sensitivity measurements the test antenna is connected to a signal generator.

## C.1.3 Substitution antenna

When measuring in the frequency range up to 1 GHz the substitution antenna shall be a  $\lambda/2$  dipole, resonant at the frequency under consideration, or a shortened dipole, calibrated to the  $\lambda/2$  dipole. When measuring in the frequency range above 4 GHz a horn radiator shall be used. For measurements between 1GHz and 4 GHz either a  $\lambda/2$  dipole or a horn radiator may be used. The centre of this antenna shall coincide with the reference point of the test sample it has replaced. This reference point shall be the volume centre of the sample when its antenna is mounted inside the cabinet, or the point where an external antenna is connected to the cabinet.

The distance between the lower extremity of the dipole and the ground shall be at least 0,3 m.

The substitution antenna shall be connected to a calibrated signal generator when the site is used for spurious radiation measurements and transmitter effective radiated power measurements. The substitution antenna shall be connected to a calibrated measuring receiver when the site is used for the measurement of receiver sensitivity.

The signal generator and the receiver shall be operating at the frequencies under investigation and shall be connected to the antenna through suitable matching and balancing networks.

NOTE: The gain of a horn antenna is generally expressed relative to an isotropic radiator.

## C.1.4 Optional additional indoor site

When the frequency of the signals being measured is greater than 80 MHz, use may be made of an indoor site. If this alternative site is used, this shall be recorded in the test report.

The measurement site may be a laboratory room with a minimum area of 6 m by 7 m and at least 2,7 m in height.

Apart from the measuring apparatus and the operator, the room shall be as free as possible from reflecting objects other than the walls, floor and ceiling.

The potential reflections from the wall behind the equipment under test are reduced by placing a barrier of absorbent material in front of it. The corner reflector around the test antenna is used to reduce the effect of reflections from the opposite wall and from the floor and ceiling in the case of horizontally polarized measurements. Similarly, the corner reflector reduces the effects of reflections from the side walls for vertically polarized measurements. For the lower part of the frequency range (below approximately 175 MHz) no corner reflector or absorbent barrier is needed. For practical reasons, the  $\lambda/2$  antenna in figure C.2 may be replaced by an antenna of constant length, provided that this length is between  $\lambda/4$  and  $\lambda$  at the frequency of measurement and the sensitivity of the measuring system is sufficient. In the same way the distance of  $\lambda/2$  to the apex may be varied.

The test antenna, measuring receiver, substitution antenna and calibrated signal generator are used in a way similar to that of the general method.

To ensure that errors are not caused by the propagation path approaching the point at which phase cancellation between direct and the remaining reflected signals occurs, the substitution antenna shall be moved through a distance of  $\pm 0,1$  m in the direction of the test antenna as well as in the two directions perpendicular to this first direction.

If these changes of distance cause a signal change of greater than 2 dB, the test sample should be re-sited until a change of less than 2 dB is obtained.

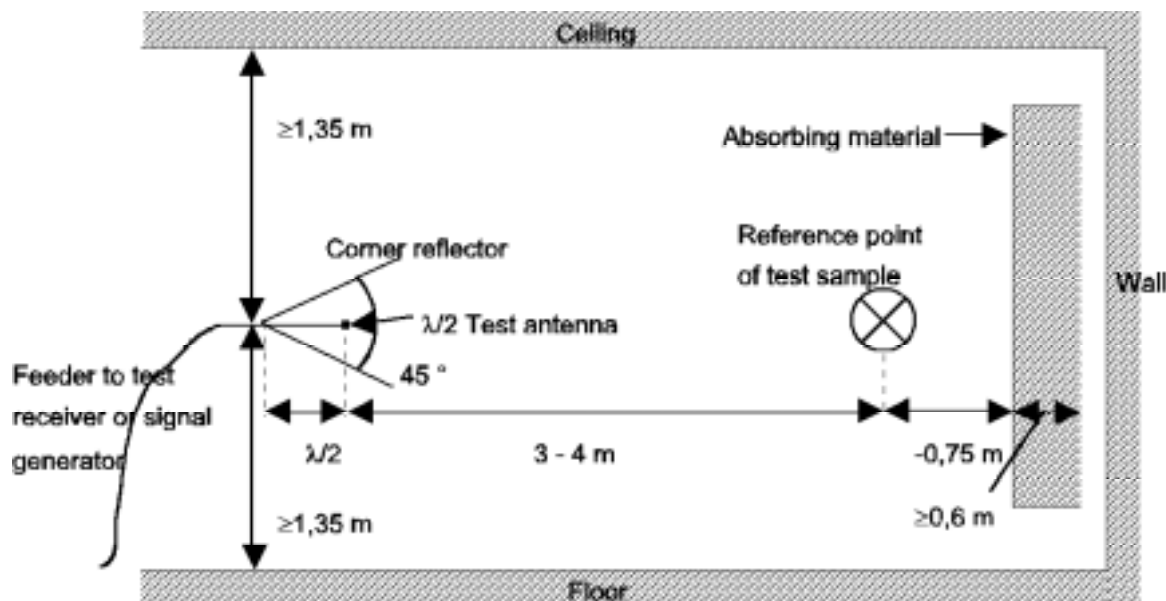

Figure C.2: Indoor site arrangement (shown for horizontal polarization)

## C.2 Guidance on the use of radiation test sites

For measurements involving the use of radiated fields, use may be made of a test site in conformity with the requirements of clause C.1. When using such a test site, the following conditions should be observed to ensure consistency of measuring results.

### C.2.1 Measuring distance

Evidence indicates that the measuring distance is not critical and does not significantly affect the measuring results, provided that the distance is not less than  $\lambda/2$  at the frequency of measurement, and the precautions described in this annex are observed. Measuring distances of 3 m, 5 m, 10 m and 30 m are in common use in European test laboratories.

### C.2.2 Test antenna

Different types of test antenna may be used, since performing substitution measurements reduces the effect of the errors on the measuring results.

Height variation of the test antenna over a range of 1 m to 4 m is essential in order to find the point at which the radiation is a maximum.

Height variation of the test antenna may not be necessary at the lower frequencies below about 100 MHz.

### C.2.3 Substitution antenna

Variations in the measuring results may occur with the use of different types of substitution antenna at the lower frequencies below about 80 MHz.

Where a shortened dipole antenna is used at these frequencies, details of the type of antenna used should be included with the results of the tests carried out on the site. Correction factors shall be taken into account when shortened dipole antennas are used.

## C.2.4 Artificial antenna

The dimensions of the artificial antenna used during radiated measurements should be small in relation to the sample under test.

Where possible, a direct connection should be used between the artificial antenna and the test sample.

In cases where it is necessary to use a connecting cable, precautions should be taken to reduce the radiation from this cable by, for example, the use of ferrite cores or double screened cables.

## C.2.5 Auxiliary cables

The position of auxiliary cables (power supply and microphone cables etc.) which are not adequately decoupled may cause variations in the measuring results. In order to get reproducible results, cables and wires of auxiliaries should be arranged vertically downwards (through a hole in the non conducting support).

## C.2.6 Acoustic measuring arrangement

When carrying out measurements of the maximum usable sensitivity (radiated) of the receiver, the audio output shall be monitored by acoustically coupling the audio signal from the receiver loudspeaker/transducer to the test microphone. On the radiation test site all conducting materials shall be placed below the ground surface and the acoustic signal is conveyed from the receiver to the test microphone in a non-conducting acoustic pipe.

The acoustic pipe shall have an appropriate length. The acoustic pipe shall have an inner diameter of 6 mm and a wall thickness of 1,5 mm. A plastic funnel of a diameter corresponding to the receiver loudspeaker/transducer shall be attached to the receiver surface centred in front of the receiver loudspeaker/transducer. The plastic funnel shall be very soft at the attachment point to the receiver in order to avoid mechanical resonance. The narrow end of the plastic funnel shall be connected to the one end of the acoustic pipe and the test microphone to the other.

---

## C.3 Further optional alternative indoor test site using an anechoic chamber

For radiation measurements when the frequency of the signals being measured is greater than 30 MHz, use may be made of an indoor site being a well-shielded anechoic chamber simulating free space environment. If such a chamber is used, this shall be recorded in the test report.

The test antenna, measuring receiver, substitution antenna and calibrated signal generator are used in a way similar to that of the general method, clause C.1. In the range between 30 MHz and 100 MHz some additional calibration may be necessary.

An example of a typical measurement site may be an electrically shielded anechoic chamber being 10 m long, 5 m broad and 5 m high.

Walls and ceiling should be coated with RF absorbers of 1 m height.

The base should be covered with absorbing material 1 m thick, and a wooden floor, able to carry test equipment and operators.

A measuring distance of 3 m to 5 m in the long middle axis of the chamber can be used for measurements up to 12,75 GHz.

The construction of the anechoic chamber is described in the following clauses.



### C.3.1 Example of the construction of a shielded anechoic chamber

Free-field measurements can be simulated in a shielded measuring chamber where the walls are coated with RF absorbers.

Figure C.3 shows the requirements for shielding loss and wall return loss of such a room.

As dimensions and characteristics of usual absorber materials are critical below 100 MHz (height of absorbers < 1 m, reflection attenuation < 20 dB) such a room is preferably suitable for measurements above 100 MHz.

Figure C.4 shows the construction of a shielded measuring chamber having a base area of 5 m by 10 m and a height of 5 m.

Ceilings and walls are coated with pyramidal formed absorbers approximately 1 m high. The base is covered with absorbers which are able to carry and which forms a sort of floor.

The available internal dimensions of the room are 3 m x 8 m x 3 m, so that a measuring distance of maximum 5 m length in the middle axis of this room is available.

At 100 MHz the measuring distance can be extended up to a maximum of 2 lambda.

The floor absorbers reject floor reflections so that the antenna height need not be changed and floor reflection influences need not be considered.

All measuring results can therefore be checked with simple calculations and the measuring tolerances have the smallest possible values due to the simple measuring configuration.

For special measurements it can be necessary to re-introduce floor reflections. Taking away the floor absorbers would mean a removal of approximately 24 m<sup>3</sup> absorber material. Therefore the floor absorbers are covered with metal plates of metallic nets instead.

### C.3.2 Influence of parasitic reflections in anechoic chambers

For free-space propagation in the far field condition the correlation  $E = E_0(R_0/R)$  is valid for the dependence of the field strength  $E$  on the distance  $R$ , whereby  $E_0$  is the reference field strength in the reference distance  $R_0$ .

It is useful to use just this correlation for comparison measurements, as all constants are eliminated with the ratio and neither cable attenuation nor antenna mismatch or antenna dimensions are of importance.

Deviations from the ideal curve can be seen easily if the logarithm of the above equation is used, because the ideal correlation of field strength and distance can then be shown as a straight line and the deviations occurring in practice are clearly visible. This indirect method shows the disturbances due to reflections more readily and is far less problematical than the direct measurement of reflection attenuation.

With an anechoic chamber of the dimensions suggested in clause C.3 at low frequencies up to 100 MHz there are no far field conditions, and therefore reflections are stronger so that careful calibration is necessary.

In the medium frequency range from 100 MHz to 1 GHz the dependence of the field strength on the distance meets the expectations very well.

In the frequency range of 1 GHz to 12,75 GHz, because more reflections will occur, the dependence of the field strength on the distance will not correlate so closely.

### C.3.3 Calibration of the shielded anechoic chamber

Careful calibration of the chamber shall be performed over the range 30 MHz to 12,75 GHz.

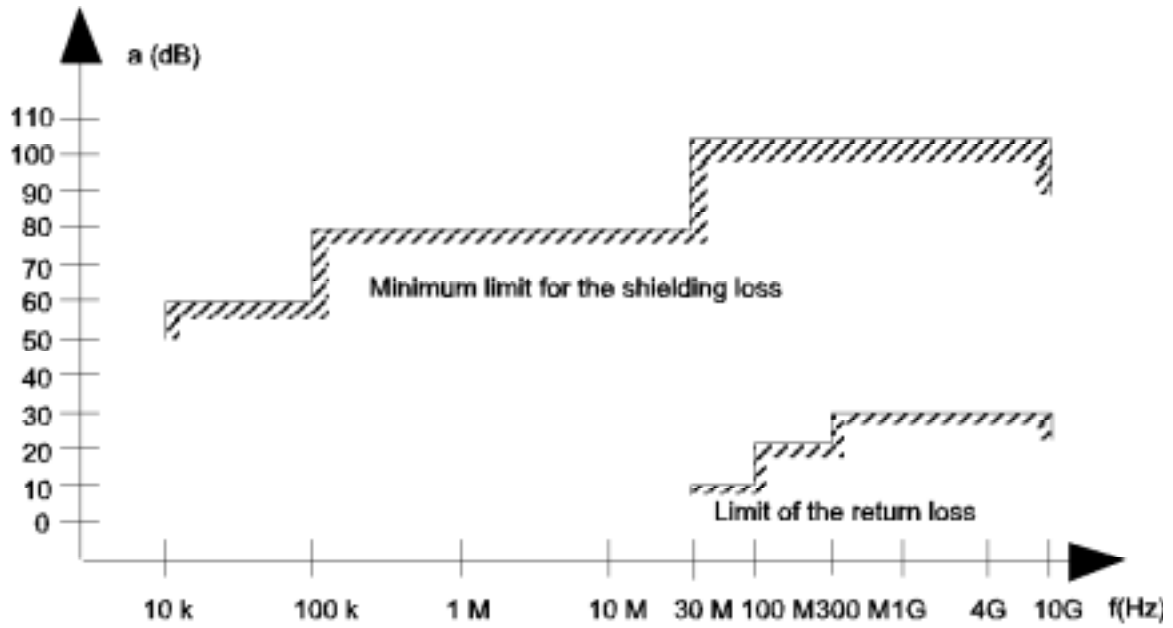
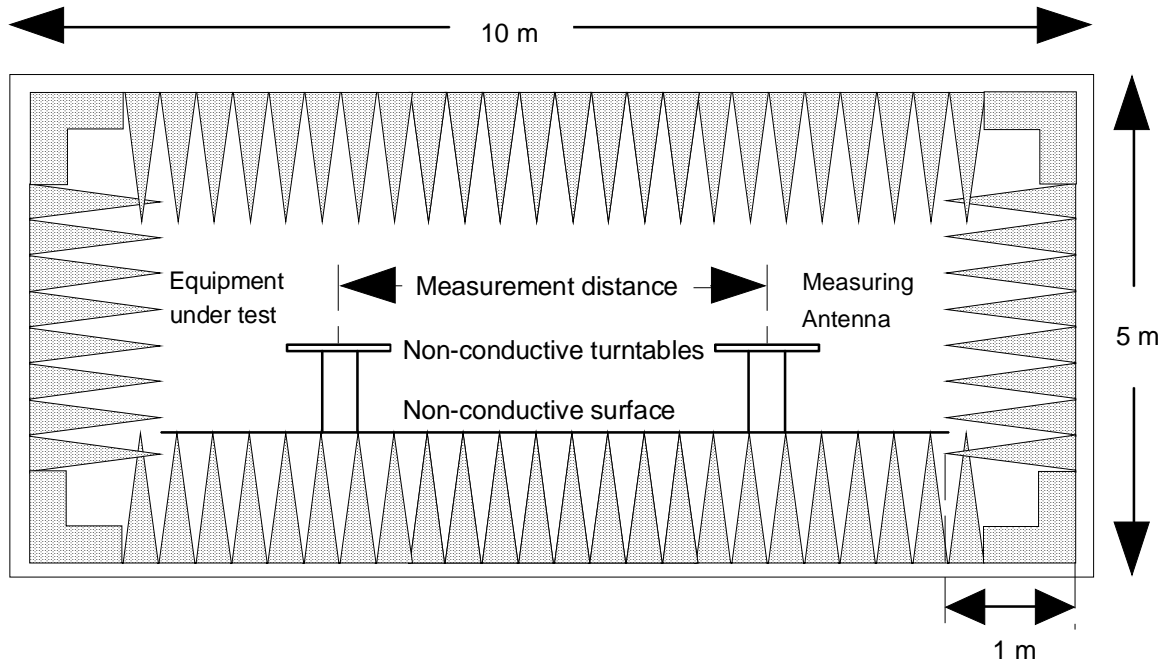

Figure C.3: Specifications for shielding and reflections



Ground plan

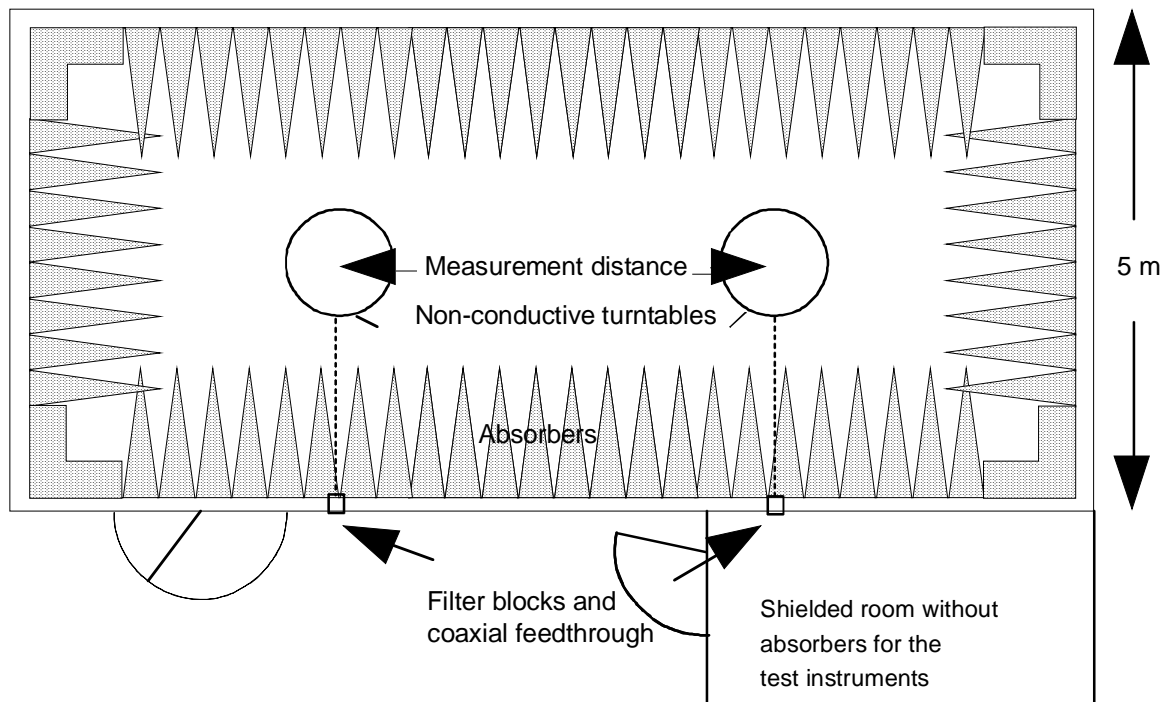

Figure C.4: Example of construction of an anechoic shielded chamber

---

## History

<b>Document history</b>		
V1.1.1	August 2001	Public Enquiry PE 20011214: 2001-08-15 to 2001-12-14