



**IMT cellular networks;
Harmonised Standard for access to radio spectrum;
Part 23: Active Antenna System (AAS) Base Station (BS);
Release 15**

ReferenceDEN/MSG-TFES-13-23

Keywords

3G, 3GPP, 4G, 5G, antenna, base station, cellular, digital, E-UTRA, IMT, IMT-2000, IMT-Advanced, LTE, LTE-Advanced, mobile, NR, radio, regulation, UMTS, UTRA, WCDMA

ETSI

650 Route des Lucioles
F-06921 Sophia Antipolis Cedex - FRANCE

Tel.: +33 4 92 94 42 00 Fax: +33 4 93 65 47 16

Siret N° 348 623 562 00017 - APE 7112B
Association à but non lucratif enregistrée à la
Sous-Préfecture de Grasse (06) N° w061004871

Important notice

The present document can be downloaded from:

<https://www.etsi.org/standards-search>

The present document may be made available in electronic versions and/or in print. The content of any electronic and/or print versions of the present document shall not be modified without the prior written authorization of ETSI. In case of any existing or perceived difference in contents between such versions and/or in print, the prevailing version of an ETSI deliverable is the one made publicly available in PDF format at www.etsi.org/deliver.

Users of the present document should be aware that the document may be subject to revision or change of status.

Information on the current status of this and other ETSI documents is available at

<https://portal.etsi.org/TB/ETSIDeliverableStatus.aspx>

If you find errors in the present document, please send your comment to one of the following services:

<https://portal.etsi.org/People/CommitteeSupportStaff.aspx>

If you find a security vulnerability in the present document, please report it through our
Coordinated Vulnerability Disclosure Program:

<https://www.etsi.org/standards/coordinated-vulnerability-disclosure>

Notice of disclaimer & limitation of liability

The information provided in the present deliverable is directed solely to professionals who have the appropriate degree of experience to understand and interpret its content in accordance with generally accepted engineering or other professional standard and applicable regulations.

No recommendation as to products and services or vendors is made or should be implied.

In no event shall ETSI be held liable for loss of profits or any other incidental or consequential damages.

Any software contained in this deliverable is provided "AS IS" with no warranties, express or implied, including but not limited to, the warranties of merchantability, fitness for a particular purpose and non-infringement of intellectual property rights and ETSI shall not be held liable in any event for any damages whatsoever (including, without limitation, damages for loss of profits, business interruption, loss of information, or any other pecuniary loss) arising out of or related to the use of or inability to use the software.

Copyright Notification

No part may be reproduced or utilized in any form or by any means, electronic or mechanical, including photocopying and microfilm except as authorized by written permission of ETSI.

The content of the PDF version shall not be modified without the written authorization of ETSI.

The copyright and the foregoing restriction extend to reproduction in all media.

© ETSI 2023.
All rights reserved.

Contents

Intellectual Property Rights	10
Foreword.....	10
Modal verbs terminology.....	11
Introduction	11
1 Scope	12
2 References	14
2.1 Normative references	14
2.2 Informative references.....	15
3 Definition of terms, symbols and abbreviations.....	17
3.1 Terms.....	17
3.2 Symbols.....	21
3.3 Abbreviations	23
4 Technical requirements specifications	24
4.1 Environmental profile.....	24
4.2 Requirement set applicability	24
4.3 Conformance requirements	25
4.3.1 Introduction.....	25
4.3.1.1 General	25
4.3.1.2 Conducted transmitter requirements	27
4.3.1.3 Conducted receiver requirements	28
4.3.1.4 Conducted requirements for BS capable of multi-band operation	28
4.3.1.5 Radiated transmitter requirements	29
4.3.1.6 Radiated receiver requirements.....	29
4.3.1.7 Radiated requirements for BS capable of multi-band operation	30
4.3.2 Operating Band Unwanted Emissions (OBUE).....	30
4.3.2.1 Definition and applicability.....	30
4.3.2.2 Limits	31
4.3.2.2.1 Limits for <i>MSR operation</i>	31
4.3.2.2.2 Limits for <i>single RAT E-UTRA operation</i>	47
4.3.2.3 Conformance.....	62
4.3.3 Spectrum Emission Mask (SEM).....	62
4.3.3.1 Definition and applicability.....	62
4.3.3.2 Limits	62
4.3.3.3 Conformance.....	67
4.3.4 Adjacent Channel Leakage power Ratio (ACLR)	67
4.3.4.1 Definition and applicability.....	67
4.3.4.2 Limits	68
4.3.4.2.1 General	68
4.3.4.2.2 Absolute limits	68
4.3.4.2.3 Relative limits for <i>MSR operation</i>	68
4.3.4.2.4 Relative limits for single RAT UTRA FDD operation.....	73
4.3.4.2.5 Relative limits for E-UTRA operation	74
4.3.4.3 Conformance.....	76
4.3.5 Transmitter spurious emissions.....	76
4.3.5.1 Definition and applicability.....	76
4.3.5.2 Limits	77
4.3.5.2.1 General spurious emissions limits	77
4.3.5.2.2 Limits for protection of the <i>BS receiver</i>	78
4.3.5.2.3 Limits for co-existence with other systems	79
4.3.5.2.4 Additional limits	81
4.3.5.3 Conformance.....	82
4.3.6 Base station maximum output power.....	82
4.3.6.1 Definition and applicability.....	82
4.3.6.2 Limits	82

4.3.6.3	Conformance	82
4.3.7	Transmit intermodulation	83
4.3.7.1	Definition and applicability.....	83
4.3.7.2	Limits	83
4.3.7.2.1	Limits for <i>MSR operation</i>	83
4.3.7.2.2	Limits for Single RAT UTRA operation.....	84
4.3.7.2.3	Limits for Single RAT E-UTRA operation	85
4.3.7.3	Conformance.....	86
4.3.8	Receiver spurious emissions	86
4.3.8.1	Definition and applicability.....	86
4.3.8.2	Limits	87
4.3.8.2.1	General limits	87
4.3.8.3	Conformance.....	87
4.3.9	Blocking.....	87
4.3.9.1	Definition and applicability.....	87
4.3.9.2	Limits	87
4.3.9.2.1	Limits for <i>MSR operation</i>	87
4.3.9.2.2	Limits for <i>single RAT UTRA operation</i>	88
4.3.9.2.3	Limits for <i>single RAT E-UTRA operation</i>	91
4.3.9.3	Conformance.....	93
4.3.10	Receiver intermodulation.....	93
4.3.10.1	Definition and applicability.....	93
4.3.10.2	Limits	94
4.3.10.2.1	Limits for <i>MSR operation</i>	94
4.3.10.2.2	Limits for single RAT UTRA operation.....	97
4.3.10.2.3	Limits for single RAT E-UTRA operation	97
4.3.10.3	Conformance.....	101
4.3.11	Adjacent Channel Selectivity (ACS), general blocking and narrowband blocking	101
4.3.11.1	Definition and applicability.....	101
4.3.11.2	Limits	102
4.3.11.2.1	Limits for <i>MSR operation</i>	102
4.3.11.2.2	Limits for <i>single RAT UTRA operation</i>	104
4.3.11.2.3	Limits for single RAT E-UTRA operation	104
4.3.11.3	Conformance.....	106
4.3.12	Reference sensitivity level.....	107
4.3.12.1	Definition and applicability.....	107
4.3.12.2	Limits	107
4.3.12.2.1	Limits for UTRA FDD operation	107
4.3.12.2.2	Limits for E-UTRA operation	107
4.3.12.2.3	Limits for NR operation	108
4.3.12.3	Conformance.....	109
4.3.13	OTA Operating Band Unwanted Emissions (OTA OBUE).....	109
4.3.13.1	Definition and applicability.....	109
4.3.13.2	Limits	109
4.3.13.2.1	Limits for <i>MSR operation</i>	109
4.3.13.2.2	Limits for <i>single RAT E-UTRA operation</i>	125
4.3.13.3	Conformance.....	139
4.3.14	OTA Spectrum Emission Mask (OTA SEM)	140
4.3.14.1	Definition and applicability.....	140
4.3.14.2	Limits	140
4.3.14.3	Conformance.....	144
4.3.15	OTA Adjacent Channel Leakage power Ratio (OTA ACLR)	145
4.3.15.1	Definition and applicability.....	145
4.3.15.2	Limits	145
4.3.15.2.1	General	145
4.3.15.2.2	Absolute limits	145
4.3.15.2.3	Relative limits.....	146
4.3.15.3	Conformance.....	154
4.3.16	OTA transmitter spurious emissions.....	154
4.3.16.1	Definition and applicability.....	154
4.3.16.2	Limits	155
4.3.16.2.1	General spurious emissions limits	155

4.3.16.2.2	Limits for protection of the <i>BS receiver</i>	156
4.3.16.2.3	Limits for co-existence with other systems	156
4.3.16.2.4	Additional limits	160
4.3.16.3	Conformance	160
4.3.17	Radiated transmit power	160
4.3.17.1	Definition and applicability	160
4.3.17.2	Limits	161
4.3.17.3	Conformance	161
4.3.18	OTA Maximum output power	161
4.3.18.1	Definition and applicability	161
4.3.18.2	Limits	161
4.3.18.3	Conformance	161
4.3.19	OTA transmitter intermodulation	161
4.3.19.1	Definition and applicability	161
4.3.19.2	Limits	162
4.3.19.2.1	Limits for <i>MSR operation</i>	162
4.3.19.2.2	Limits for single RAT UTRA operation	163
4.3.19.2.3	Limits for single RAT E-UTRA operation	164
4.3.19.3	Conformance	164
4.3.20	OTA receiver spurious emissions	164
4.3.20.1	Definition and applicability	164
4.3.20.2	Limits	165
4.3.20.3	Conformance	165
4.3.21	OTA blocking	165
4.3.21.1	Definition and applicability	165
4.3.21.2	Limits	166
4.3.21.2.1	Limits for <i>MSR operation</i>	166
4.3.21.2.2	Limits for <i>Single RAT UTRA operation</i>	166
4.3.21.2.3	Limits for <i>single RAT E-UTRA operation</i>	167
4.3.21.3	Conformance	168
4.3.22	OTA receiver intermodulation	169
4.3.22.1	Definition and applicability	169
4.3.22.2	Limits	169
4.3.22.2.1	Limits for <i>MSR operation</i>	169
4.3.22.2.2	Limits for single RAT UTRA operation	172
4.3.22.2.3	Limits for single RAT E-UTRA operation	174
4.3.22.3	Conformance	178
4.3.23	OTA Adjacent Channel Selectivity (OTA ACS), general blocking and narrowband blocking	178
4.3.23.1	Definition and applicability	178
4.3.23.2	Limits	179
4.3.23.2.1	Limits for <i>MSR operation</i>	179
4.3.23.2.2	Limits for <i>Single RAT UTRA FDD operation</i>	181
4.3.23.2.3	Limits for <i>single RAT E-UTRA operation</i>	182
4.3.23.3	Conformance	184
4.3.24	OTA Sensitivity	184
4.3.24.1	Definition and applicability	184
4.3.24.2	Limits	184
4.3.24.2.1	Limits for UTRA operation	184
4.3.24.2.2	Limits for E-UTRA operation	185
4.3.24.2.3	Limits for NR operation	185
4.3.24.3	Conformance	185
4.3.25	OTA Reference sensitivity level	186
4.3.25.1	Definition and applicability	186
4.3.25.2	Limits	186
4.3.25.2.1	Limits for UTRA FDD operation	186
4.3.25.2.2	Limits for E-UTRA operation	186
4.3.25.2.3	Limits for NR operation	187
4.3.25.3	Conformance	188
5	Testing for compliance with technical requirements	188
5.1	Environmental conditions for testing	188
5.2	Interpretation of the measurement results	189

5.3	Essential radio test suites.....	189
5.3.1	Introduction.....	189
5.3.2	<i>Operating band unwanted emissions</i>	189
5.3.2.1	General.....	189
5.3.2.2	Initial conditions	189
5.3.2.3	Procedure	189
5.3.2.4	Test requirement	190
5.3.3	Spectrum Emission Mask (SEM).....	190
5.3.3.1	General.....	190
5.3.3.2	Initial conditions	190
5.3.3.3	Procedure	191
5.3.3.4	Test requirement	191
5.3.4	Adjacent Channel Leakage power Ratio (ACLR)	191
5.3.4.1	General.....	191
5.3.4.2	Initial conditions	191
5.3.4.2.1	General test conditions	191
5.3.4.2.2	MSR	192
5.3.4.2.3	UTRA FDD	192
5.3.4.2.4	E-UTRA	192
5.3.4.3	Procedure	192
5.3.4.3.1	General procedure	192
5.3.4.3.2	MSR	192
5.3.4.3.3	UTRA FDD	193
5.3.4.3.4	E-UTRA	193
5.3.5	Transmitter spurious emissions.....	193
5.3.5.1	General.....	193
5.3.5.2	Initial conditions	194
5.3.5.3	Procedure	194
5.3.5.4	Test requirement	195
5.3.6	Base station output power.....	195
5.3.6.1	General.....	195
5.3.6.2	Initial conditions	195
5.3.6.3	Procedure	195
5.3.6.4	Test requirement	195
5.3.7	Transmit intermodulation	196
5.3.7.1	General.....	196
5.3.7.2	Initial conditions	196
5.3.7.3	Procedure	196
5.3.7.3.1	Procedure for co-location requirement	196
5.3.7.3.2	Procedure for intra-system requirement	198
5.3.7.4	Test requirement	199
5.3.8	Receiver spurious emissions	199
5.3.8.1	General.....	199
5.3.8.2	Initial conditions	199
5.3.8.3	Procedure	199
5.3.8.4	Test requirement	199
5.3.9	Blocking.....	200
5.3.9.1	General.....	200
5.3.9.2	Initial conditions	200
5.3.9.3	Procedure	200
5.3.9.3.1	General procedure	200
5.3.9.3.2	<i>MSR operation</i>	200
5.3.9.3.3	Single RAT UTRA FDD operation.....	201
5.3.9.3.4	<i>Single RAT E-UTRA operation</i>	201
5.3.9.4	Test requirement	201
5.3.10	Receiver intermodulation characteristics	202
5.3.10.1	General.....	202
5.3.10.2	Initial conditions	202
5.3.10.3	Procedure	202
5.3.10.3.1	General procedure	202
5.3.10.3.2	MSR procedure.....	202
5.3.10.3.3	Procedure for single RAT UTRA FDD operation	203

5.3.10.3.4	Procedure for <i>single RAT E-UTRA operation</i>	203
5.3.10.4	Test requirement	203
5.3.11	Adjacent Channel Selectivity (ACS), general blocking and narrowband blocking	203
5.3.11.1	General	203
5.3.11.2	Initial conditions	203
5.3.11.3	Procedure	204
5.3.11.3.1	General procedure	204
5.3.11.3.2	<i>MSR operation</i>	204
5.3.11.3.3	Single RAT UTRA FDD operation.....	205
5.3.11.3.4	<i>Single RAT E-UTRA operation</i>	205
5.3.11.4	Test requirement	206
5.3.12	Reference sensitivity level.....	206
5.3.12.1	General	206
5.3.12.2	Initial conditions	206
5.3.12.3	Procedure	206
5.3.12.4	Test requirement	206
5.3.13	OTA operating band unwanted emissions	207
5.3.13.1	General	207
5.3.13.2	Initial conditions	207
5.3.13.3	Procedure	207
5.3.13.4	Test requirement	208
5.3.14	OTA Spectrum Emission Mask (OTA SEM)	208
5.3.14.1	General	208
5.3.14.2	Initial conditions	208
5.3.14.3	Procedure	208
5.3.14.4	Test requirement	209
5.3.15	OTA Adjacent Channel Leakage power Ratio (OTA ACLR)	209
5.3.15.1	General	209
5.3.15.2	Initial conditions	209
5.3.15.2.1	General test conditions	209
5.3.15.2.2	MSR	210
5.3.15.2.3	UTRA FDD	210
5.3.15.2.4	E-UTRA	210
5.3.15.2.5	NR	210
5.3.15.3	Procedure	210
5.3.15.3.1	General procedure	210
5.3.15.3.2	MSR	211
5.3.15.3.3	UTRA FDD	211
5.3.15.3.4	E-UTRA	211
5.3.15.4	Test requirement	212
5.3.16	OTA transmitter spurious emissions.....	212
5.3.16.1	General	212
5.3.16.2	General spurious emissions.....	212
5.3.16.2.1	General	212
5.3.16.2.2	Initial conditions	212
5.3.16.2.3	Procedure.....	213
5.3.16.2.4	Test requirement	214
5.3.16.3	Protection of the <i>BS receiver</i>	214
5.3.16.3.1	General	214
5.3.16.3.2	Initial conditions.....	214
5.3.16.3.3	Procedure.....	214
5.3.16.3.4	Test requirement	215
5.3.16.4	Co-existence with other systems	215
5.3.16.4.1	General	215
5.3.16.4.2	Initial conditions	215
5.3.16.4.3	Procedure.....	216
5.3.16.4.4	Test requirement	217
5.3.17	Radiated transmit power	217
5.3.17.1	General	217
5.3.17.2	Initial conditions	217
5.3.17.3	Procedure	217
5.3.17.4	Test requirement	218

5.3.18	OTA Maximum output power	218
5.3.18.1	General	218
5.3.18.2	Initial conditions	218
5.3.18.3	Procedure	218
5.3.18.4	Test requirement	219
5.3.19	OTA transmitter intermodulation	219
5.3.19.1	General	219
5.3.19.2	Initial conditions	219
5.3.19.3	Procedure	220
5.3.19.4	Test requirement	222
5.3.20	OTA receiver spurious emissions	222
5.3.20.1	General	222
5.3.20.2	Initial conditions	222
5.3.20.3	Procedure	222
5.3.20.4	Test requirement	223
5.3.21	OTA blocking	223
5.3.21.1	General	223
5.3.21.2	Initial conditions	223
5.3.21.3	Procedure	224
5.3.21.3.1	General procedure	224
5.3.21.3.2	<i>MSR operation</i>	224
5.3.21.3.3	Single RAT UTRA FDD operation	224
5.3.21.3.4	<i>Single RAT E-UTRA operation</i>	225
5.3.21.4	Test requirement	225
5.3.22	OTA receiver intermodulation.....	225
5.3.22.1	General	225
5.3.22.2	Initial conditions	226
5.3.22.3	Procedure	226
5.3.22.3.1	General procedure	226
5.3.22.3.2	<i>MSR operation</i>	226
5.3.22.3.3	Single RAT UTRA FDD operation	227
5.3.22.3.4	<i>Single RAT E-UTRA operation</i>	227
5.3.22.4	Test requirement	227
5.3.23	OTA Adjacent Channel Selectivity (OTA ACS)	227
5.3.23.1	General	227
5.3.23.2	Initial conditions	228
5.3.23.3	Procedure	228
5.3.23.3.1	General procedure	228
5.3.23.3.2	<i>MSR operation</i>	228
5.3.23.3.3	Single RAT UTRA FDD operation	229
5.3.23.3.4	<i>Single RAT E-UTRA operation</i>	229
5.3.23.4	Test requirement	230
5.3.24	OTA sensitivity.....	230
5.3.24.1	General	230
5.3.24.2	Initial conditions	230
5.3.24.3	Procedure	231
5.3.24.4	Test requirement	231
5.3.25	OTA reference sensitivity level	231
5.3.25.1	General	231
5.3.25.2	Initial conditions	231
5.3.25.3	Procedure	232
5.3.25.4	Test requirement	232
Annex A (informative):	Relationship between the present document and the essential requirements of Directive 2014/53/EU	233
Annex B (informative):	Maximum Measurement Uncertainty.....	235
Annex C (normative):	Base Station configurations for conducted testing.....	238
C.1	Transmit configurations	238
C.2	Receive configurations.....	238

C.3	Power supply options	239
C.4	BS with integrated Iuant BS modem	239
Annex D (normative):	Base Station configurations for radiated testing.....	240
D.1	Transmit configurations	240
D.2	Receive configurations	241
D.3	Power supply options	242
D.4	BS with integrated Iuant BS modem	242
Annex E (informative):	Checklist	243
Annex F (informative):	Bibliography.....	244
Annex G (informative):	Change history	245
History		246

Intellectual Property Rights

Essential patents

IPRs essential or potentially essential to normative deliverables may have been declared to ETSI. The declarations pertaining to these essential IPRs, if any, are publicly available for **ETSI members and non-members**, and can be found in ETSI SR 000 314: "*Intellectual Property Rights (IPRs); Essential, or potentially Essential, IPRs notified to ETSI in respect of ETSI standards*", which is available from the ETSI Secretariat. Latest updates are available on the ETSI Web server (<https://ipr.etsi.org/>).

Pursuant to the ETSI Directives including the ETSI IPR Policy, no investigation regarding the essentiality of IPRs, including IPR searches, has been carried out by ETSI. No guarantee can be given as to the existence of other IPRs not referenced in ETSI SR 000 314 (or the updates on the ETSI Web server) which are, or may be, or may become, essential to the present document.

Trademarks

The present document may include trademarks and/or tradenames which are asserted and/or registered by their owners. ETSI claims no ownership of these except for any which are indicated as being the property of ETSI, and conveys no right to use or reproduce any trademark and/or tradename. Mention of those trademarks in the present document does not constitute an endorsement by ETSI of products, services or organizations associated with those trademarks.

DECT™, **PLUGTESTS™**, **UMTS™** and the ETSI logo are trademarks of ETSI registered for the benefit of its Members. **3GPP™** and **LTE™** are trademarks of ETSI registered for the benefit of its Members and of the 3GPP Organizational Partners. **oneM2M™** logo is a trademark of ETSI registered for the benefit of its Members and of the oneM2M Partners. **GSM®** and the GSM logo are trademarks registered and owned by the GSM Association.

Foreword

This final draft Harmonised European Standard (EN) has been produced by ETSI Technical Committee Mobile Standards Group (MSG), and is now submitted for the Vote phase of the ETSI standards EN Approval Procedure.

For non-EU countries the present document may be used for regulatory (Type Approval) purposes.

The present document has been prepared under Commission's standardisation request C(2015) 5376 final [i.1] to provide one voluntary means of conforming to the essential requirements of Directive 2014/53/EU on the harmonisation of the laws of the Member States relating to the making available on the market of radio equipment and repealing Directive 1999/5/EC [i.2].

Once the present document is cited in the Official Journal of the European Union under that Directive, compliance with the normative clauses of the present document given in table A.1 confers, within the limits of the scope of the present document, a presumption of conformity with the corresponding essential requirements of that Directive and associated EFTA regulations.

The present document is part 23 of a multi-part deliverable. Full details of the entire series can be found in part 1 [i.6].

Proposed national transposition dates	
Date of latest announcement of this EN (doa):	3 months after ETSI publication
Date of latest publication of new National Standard or endorsement of this EN (dop/e):	6 months after doa
Date of withdrawal of any conflicting National Standard (dow):	18 months after doa

Modal verbs terminology

In the present document "**shall**", "**shall not**", "**should**", "**should not**", "**may**", "**need not**", "**will**", "**will not**", "**can**" and "**cannot**" are to be interpreted as described in clause 3.2 of the [ETSI Drafting Rules](#) (Verbal forms for the expression of provisions).

"**must**" and "**must not**" are **NOT** allowed in ETSI deliverables except when used in direct citation.

Introduction

The present document is part of a set of standards developed by ETSI that are designed to fit in a modular structure to cover radio equipment within the scope of the Radio Equipment Directive [i.2]. The present document is produced following the guidance in ETSI EG 203 336 [i.3] as applicable.

1 Scope

The present document specifies technical characteristics and methods of measurements for types of radio equipment:

- AAS BS supporting Single-RAT UTRA FDD.
- AAS BS supporting Single-RAT E-UTRA.
- AAS BS supporting Multi-Standard Radio (UTRA-FDD, E-UTRA, NR).

In the present document, the term "requirements for single RAT operation" refers to requirements that are derived from the ETSI TS 125 141 [7] or ETSI TS 136 141 [11] specifications baseline. The term "requirements for MSR operation" refers to requirements derived from the ETSI TS 137 141 [6] specification baseline (including NR operation as part of MSR).

These radio equipment types are capable of operating in whole or any part of the frequency band(s) given in table 1-1.

Table 1-1: AAS BS operating bands

Band designation for operation as:		Band Category	Direction of transmission	AAS BS operating bands	Relevant EC/ECC decision
Single-RAT E-UTRA or MSR (note 1)	Single-RAT UTRA				
1	I	BC1	Transmit	2 110 MHz to 2 170 MHz	[i.20] and [i.21]
			Receive	1 920 MHz to 1 980 MHz	
3	III	BC2	Transmit	1 805 MHz to 1 880 MHz	[i.18] and [i.19]
			Receive	1 710 MHz to 1 785 MHz	
7	VII	BC1	Transmit	2 620 MHz to 2 690 MHz	[i.23] and [i.24]
			Receive	2 500 MHz to 2 570 MHz	
8	VIII	BC2	Transmit	925 MHz to 960 MHz	[i.18] and [i.19]
			Receive	880 MHz to 915 MHz	
20	XX	BC1	Transmit	791 MHz to 821 MHz	[i.13] and [i.14]
			Receive	832 MHz to 862 MHz	
22	XXII	BC1	Transmit	3 510 MHz to 3 590 MHz	[i.8] and [i.25]
			Receive	3 410 MHz to 3 490 MHz	
28	NA	BC1 (notes 2 and 3)	Transmit	758 MHz to 803 MHz	[i.11] and [i.12]
			Receive	703 MHz to 748 MHz	
31	NA	BC1 (note 2)	Transmit	462,5 MHz to 467,5 MHz	[i.10]
			Receive	452,5 MHz to 457,5 MHz	
32	XXXII	BC1 (note 7)	Transmit	1 452 MHz to 1 496 MHz	[i.15] and [i.16]
			Receive	N/A	
33	NA	BC3	Transmit and Receive	1 900 MHz to 1 920 MHz	[i.19]
34	NA	BC3	Transmit and Receive	2 010 MHz to 2 025 MHz	[i.19]
38	NA	BC3	Transmit and Receive	2 570 MHz to 2 620 MHz	[i.23] and [i.24]
40	NA	BC3	Transmit and Receive	2 300 MHz to 2 400 MHz	[i.22]
41	NA	BC3 (note 4)	Transmit and Receive	2 496 MHz to 2 690 MHz	[i.23] and [i.24]
42	NA	BC3	Transmit and Receive	3 400 MHz to 3 600 MHz	[i.8] and [i.25]
43	NA	BC3	Transmit and Receive	3 600 MHz to 3 800 MHz	[i.8] and [i.25]
50	NA	BC3 (note 7)	Transmit and Receive	1 432 MHz to 1 517 MHz	[i.15], [i.16] and [i.17]
51	NA	BC3 (note 7)	Transmit and Receive	1 427 MHz to 1 432 MHz	[i.15] and [i.16]
65	NA	BC1 (notes 2 and 8)	Transmit	2 110 MHz to 2 200 MHz	[i.20], [i.21] and [i.26]
			Receive	1 920 MHz to 2 010 MHz	

Band designation for operation as:		Band Category	Direction of transmission	AAS BS <i>operating bands</i>	Relevant EC/ECC decision
Single-RAT E-UTRA or MSR (note 1)	Single-RAT UTRA				
67	NA	BC1 (notes 2 and 7)	Transmit	738 MHz to 758 MHz	[i.11] and [i.12]
			Receive	N/A	
68	NA	BC1 (note 10)	Transmit	753 MHz to 783 MHz	[i.11] and [i.12]
			Receive	698 MHz to 728 MHz	
69	NA	BC1 (notes 2 and 7)	Transmit	2 570 MHz to 2 620 MHz	[i.23] and [i.24]
			Receive	N/A	
72	NA	BC1 (note 2)	Transmit	461 MHz to 466 MHz	[i.10]
			Receive	451 MHz to 456 MHz	
75	NA	BC1 (notes 2 and 7)	Transmit	1 432 MHz to 1 517 MHz	[i.15], [i.16] and [i.17]
			Receive	N/A	
76	NA	BC1 (notes 2 and 7)	Transmit	1 427 MHz to 1 432 MHz	[i.15] and [i.16]
			Receive	N/A	
77	NA	BC3 (notes 5 and 9)	Transmit and Receive	3 300 MHz to 4 200 MHz	[i.8] and [i.25]
78	NA	BC3 (notes 6 and 9)	Transmit and Receive	3 300 MHz to 3 800 MHz	[i.8] and [i.25]
87	NA	BC1 (note 10)	Transmit	420 MHz to 425 MHz	[i.10]
			Receive	410 MHz to 415 MHz	
88	NA	BC1 (note 10)	Transmit	422 MHz to 427 MHz	[i.10]
			Receive	412 MHz to 417 MHz	

NOTE 1: The band designations given are the MSR BS band designations. The relation between the band designations for MSR BS and the designations for NR, E-UTRA and UTRA are given in table 4.4-1 of ETSI TS 137 141 [6].

NOTE 2: The band is for NR and/or E-UTRA only.

NOTE 3: In Europe, according to [i.13] and [i.14], radio equipment in band 28 operates between 758 MHz and 791 MHz for the transmitter ($F_{DL_low} = 758$ MHz and $F_{DL_high} = 791$ MHz) and between 703 MHz and 736 MHz for the receiver ($F_{UL_low} = 703$ MHz and $F_{UL_high} = 736$ MHz).

NOTE 4: In Europe according to [i.22] and [i.23], radio equipment in band 41 operates between 2 570 MHz and 2 620 MHz ($F_{DL_low} = 2 570$ MHz and $F_{DL_high} = 2 620$ MHz).

NOTE 5: In Europe, according to [i.24] and [i.8], radio equipment in band n77 operates between 3 400 MHz and 3 800 MHz ($F_{DL_low} = 3 400$ MHz and $F_{DL_high} = 3 800$ MHz).

NOTE 6: In Europe, according to [i.24] and [i.8], radio equipment in band n78 operates between 3 400 MHz and 3 800 MHz ($F_{DL_low} = 3 400$ MHz and $F_{DL_high} = 3 800$ MHz).

NOTE 7: Radio equipment in bands 32, 50, 51, 67, 69, 75 and 76 only operates in transmit mode (downlink only). Only transmitter requirements are applicable.

NOTE 8: This band includes two frequency ranges that are harmonised in Europe:

- (a) According to [i.21] and [i.22], radio equipment in band n65 operates between 2 110 MHz and 2 170 MHz for the transmitter ($F_{DL_low} = 2 110$ MHz and $F_{DL_high} = 2 170$ MHz), and between 1 920 MHz and 1 980 MHz for the receiver ($F_{UL_low} = 1 920$ MHz and $F_{UL_high} = 1 980$ MHz).
- (b) Based on [i.26], radio equipment in band n65 operates between 2 170 MHz and 2 200 MHz for the transmitter ($F_{DL_low} = 2 170$ MHz and $F_{DL_high} = 2 200$ MHz) and between 1 980 MHz and 2 010 MHz for the receiver ($F_{UL_low} = 1 980$ MHz and $F_{UL_high} = 2 010$ MHz) as the Complementary Ground Component (CGC) of a Mobile-satellite service by reference to the present document.

NOTE 9: The band is for NR only.

NOTE 10: The band is for E-UTRA only.

NOTE 1: For BS capable of multi-band operation, the supported *operating bands* may belong to different Band Categories.

NOTE 2: AAS BS does not support GSM/EDGE, but BC2 is still applicable for protection of/against GSM/EDGE operation in BC2 *operating bands*.

NOTE 3: AAS BS does not support Narrow-Band Internet of Things (NB-IoT) in band, NB-IoT guard band, or standalone NB-IoT operation, but NB-IoT limits are still applicable for AAS BS protection of/against NB-IoT operation in *operating bands*.

NOTE 4: AAS BS does not support band 46 operation, but band 46 limits are still applicable for AAS BS protection of/against devices operating in band 46.

NOTE 5: The band categories for BS are defined in clause 4.4 of ETSI TS 137 141 [6] and are listed in table 1-1.

AAS BS supports *carrier aggregation* as defined in tables 4.2.1-3 to 4.2.1-6 in ETSI EN 301 908-14 [5], or tables 4.2.1-2 to 4.2.1-7 in ETSI EN 301 908-18 [4], except for the CA combinations involving band 46.

The present document covers conducted and radiated requirements for AAS BS capable of single-RAT UTRA, single-RAT E-UTRA and MSR multi-RAT operation (UTRA, E-UTRA, NR) in 3GPP™ Release 15. Additionally, it includes for selected AAS BS *operating bands* from 3GPP Release 16.

NOTE 6: The relationship between the present document and essential requirements of article 3.2 of Directive 2014/53/EU [i.2] is given in annex A.

2 References

2.1 Normative references

References are either specific (identified by date of publication and/or edition number or version number) or non-specific. For specific references, only the cited version applies. For non-specific references, the latest version of the referenced document (including any amendments) applies.

Referenced documents which are not found to be publicly available in the expected location might be found at <https://docbox.etsi.org/Reference/>.

NOTE: While any hyperlinks included in this clause were valid at the time of publication, ETSI cannot guarantee their long term validity.

The following referenced documents are necessary for the application of the present document.

- [1] [ETSI TS 137 105 \(V15.18.0\) \(04-2023\)](#): "Universal Mobile Telecommunications System (UMTS); LTE; 5G; Active Antenna System (AAS) Base Station (BS) transmission and reception (3GPP TS 37.105 version 15.18.0 Release 15)".
- [2] [ETSI TS 137 145-1 \(V15.14.0\) \(07-2022\)](#): "Universal Mobile Telecommunications System (UMTS); LTE; 5G; Active Antenna System (AAS) Base Station (BS) conformance testing; Part 1: conducted conformance testing (3GPP TS 37.145-1 version 15.14.0 Release 15)".
- [3] [ETSI TS 137 145-2 \(V15.15.0\) \(07-2022\)](#): "Universal Mobile Telecommunications System (UMTS); LTE; 5G; Active Antenna System (AAS) Base Station (BS) conformance testing; Part 2: radiated conformance testing (3GPP TS 37.145-2 version 15.14.0 Release 15)".
- [4] [ETSI EN 301 908-18 \(V15.1.1\) \(09-2021\)](#): "IMT cellular networks; Harmonised Standard for access to radio spectrum; Part 18: E-UTRA, UTRA and GSM/EDGE Multi-Standard Radio (MSR) Base Station (BS) Release 15".
- [5] [ETSI EN 301 908-14 \(V15.1.1\) \(09-2021\)](#): "IMT cellular networks; Harmonised Standard for access to radio spectrum; Part 14: Evolved Universal Terrestrial Radio Access (E-UTRA) Base Stations (BS) Release 15".
- [6] [ETSI TS 137 141 \(V15.20.0\) \(01-2023\)](#): "Digital cellular telecommunications system (Phase 2+) (GSM); Universal Mobile Telecommunications System (UMTS); LTE; 5G; NR, E-UTRA, UTRA and GSM/EDGE; Multi-Standard Radio (MSR) Base Station (BS) conformance testing (3GPP TS 37.141 version 15.20.0 Release 15)".
- [7] [ETSI TS 125 141 \(V15.4.0\) \(04-2019\)](#): "Universal Mobile Telecommunications System (UMTS); Base Station (BS) conformance testing (FDD) (3GPP TS 25.141 version 15.4.0 Release 15)".
- [8] [ETSI TS 145 004 \(V15.0.0\) \(07-2018\)](#): "Digital cellular telecommunications system (Phase 2+) (GSM); GSM/ EDGE Modulation (3GPP TS 45.004 version 15.0.0 Release 15)".
- [9] [ETSI TS 136 104 \(V15.15.0\) \(04-2022\)](#): "LTE; Evolved Universal Terrestrial Radio Access (E-UTRA); Base Station (BS) radio transmission and reception (3GPP TS 36.104 version 15.15.0 Release 15)".

- [10] [ETSI TS 125 104 \(V15.5.0\) \(04-2019\)](#): "Universal Mobile Telecommunications System (UMTS); Base Station (BS) radio transmission and reception (FDD) (3GPP TS 25.104 version 15.5.0 Release 15)".
- [11] [ETSI TS 136 141 \(V15.18.0\) \(04-2023\)](#): "LTE; Evolved Universal Terrestrial Radio Access (E-UTRA); Base Station (BS) conformance testing (3GPP TS 36.141 version 15.18.0 Release 15)".
- [12] [ETSI TS 138 141-1 \(V15.14.0\) \(01-2023\)](#): "5G; NR; Base Station (BS) conformance testing Part 1: Conducted conformance testing (3GPP TS 38.141-1 version 15.14.0 Release 15)".
- [13] [ETSI TS 138 104 \(V15.18.0\) \(10-2022\)](#): "5G; NR; Base Station (BS) radio transmission and reception (3GPP TS 38.104 version 15.18.0 Release 15)".
- [14] [ETSI EN 301 908-24 \(V15.0.1\) \(07-2023\)](#): "IMT cellular networks; Harmonised Standard for access to radio spectrum Part 24: New Radio (NR) Base Stations (BS); Release 15".
- [15] [ETSI TS 138 141-2 \(V15.17.0\) \(05-2023\)](#): "5G; NR; Base Station (BS) conformance testing Part 2: Radiated conformance testing (3GPP TS 38.141-2 version 15.17.0 Release 15)".

2.2 Informative references

References are either specific (identified by date of publication and/or edition number or version number) or non-specific. For specific references, only the cited version applies. For non-specific references, the latest version of the referenced document (including any amendments) applies.

NOTE: While any hyperlinks included in this clause were valid at the time of publication, ETSI cannot guarantee their long term validity.

The following referenced documents are not necessary for the application of the present document but they assist the user with regard to a particular subject area.

- [i.1] [Commission implementing decision C\(2015\) 5376 final of 4.8.2015](#) on a standardisation request to the European Committee for Electrotechnical Standardisation and to the European Telecommunications Standards Institute as regards radio equipment in support of Directive 2014/53/EU of the European Parliament and of the Council.
- [i.2] [Directive 2014/53/EU](#) of the European parliament and of the council of 16 April 2014 on the harmonisation of the laws of the Member States relating to the making available on the market of radio equipment and repealing Directive 1999/5/EC.
- [i.3] ETSI EG 203 336 (V1.2.1) (05-2020): "Guide for the selection of technical parameters for the production of Harmonised Standards covering article 3.1(b) and article 3.2 of Directive 2014/53/EU".
- [i.4] Recommendation ITU-R SM.329-12 (09-2012): "Unwanted emissions in the spurious domain".
- [i.5] ETSI TR 100 028 (parts 1 and 2) (V1.4.1) (12-2001): "Electromagnetic compatibility and Radio spectrum Matters (ERM); Uncertainties in the measurement of mobile radio equipment characteristics".
- [i.6] ETSI EN 301 908-1 (V15.1.1) (09-2021): "IMT cellular networks; Harmonised Standard for access to radio spectrum; Part 1: Introduction and common requirements Release 15".
- [i.7] ETSI TR 103 877: "Task Force for European Standards for IMT-2000 (MSG); Technical Parameter selection in ETSI EN 301 908 Base Station (BS) Harmonised Standards".
- [i.8] [Commission implementing Decision \(EU\) 2019/235 of 24 January 2019](#) on amending Decision 2008/411/EC as regards an update of relevant technical conditions applicable to the 3400-3800 MHz frequency band.
- [i.9] ETSI TS 103 807 (V1.1.1) (10-2021): "Mobile Standards Group (MSG); IMT Cellular Networks Base Stations (BS) Additional Regulatory Requirements".

- [i.10] [ECC Decision \(16\)02](#): "Harmonised technical conditions and frequency bands for the implementation of Broadband Public Protection and Disaster Relief (BB-PPDR) systems", Approved 17 June 2016, Amended 8 March 2019.
- [i.11] [Commission Implementing Decision \(EU\) 2016/687 of 28 April 2016](#) on the harmonisation of the 694-790 MHz frequency band for terrestrial systems capable of providing wireless broadband electronic communications services and for flexible national use in the Union.
- [i.12] [ECC Decision \(15\)01](#): "Harmonised technical conditions for mobile/fixed communications networks (MFCN) in the band 694-790 MHz including a paired frequency arrangement (Frequency Division Duplex 2x30 MHz) and an optional unpaired frequency arrangement (Supplemental Downlink)", Approved 06 March 2015.
- [i.13] [Commission Decision 2010/267/EU of 6 May 2010](#) on harmonised technical conditions of use in the 790-862 MHz frequency band for terrestrial systems capable of providing electronic communications services in the European Union.
- [i.14] [ECC Decision \(09\)03](#): "Harmonised conditions for mobile/fixed communications networks (MFCN) operating in the band 790 - 862 MHz", 30 October 2009.
- [i.15] [Commission Implementing Decision \(EU\) 2018/661 of 26 April 2018](#) amending Implementing Decision (EU) 2015/750 on the harmonisation of the 1452-1492 MHz frequency band for terrestrial systems capable of providing electronic communications services in the Union as regards its extension in the harmonised 1427-1452 MHz and 1492-1517 MHz frequency bands.
- [i.16] [ECC Decision \(13\)03](#): "The harmonised use of the frequency band 1452-1492 MHz for Mobile/Fixed Communications Networks Supplemental Downlink (MFCN SDL)", Approved 8 November 2013, Amended 02 March 2018.
- [i.17] [ECC Decision \(17\)06](#): "The harmonised use of the frequency bands 1427-1452 MHz and 1492-1518 MHz for Mobile/Fixed Communications Networks Supplemental Downlink (MFCN SDL)", Approved 17 November 2017, corrected 2 March 2018.
- [i.18] [Commission Implementing Decision \(EU\) 2022/173 of 7 February 2022](#) on the harmonisation of the 900 MHz and 1800 MHz frequency bands for terrestrial systems capable of providing electronic communications services in the Union and repealing Decision 2009/766/EC.
- [i.19] [ECC Decision \(06\)13](#): "Designation of the bands 880-915 MHz, 925-960 MHz, 1710-1785 MHz and 1805-1880 MHz for terrestrial UMTS, LTE, WiMAX and IoT cellular systems", Approved 01 December 2006, Amended 8 March 2019.
- [i.20] [Commission Implementing Decision \(EU\) 2020/667 of 6 May 2020](#) amending Decision 2012/688/EU as regards an update of relevant technical conditions applicable to the frequency bands 1 920-1 980 MHz and 2 110-2 170 MHz.
- [i.21] [ECC Decision \(06\)01](#): "The harmonised utilisation of the bands 1920-1980 MHz and 2110-2170 MHz for mobile/fixed communications networks (MFCN) including terrestrial IMT systems", Approved 24 March 2006, Amended 8 March 2019.
- [i.22] [ECC Decision \(14\)02](#): "Harmonised technical and regulatory conditions for the use of the band 2300-2400 MHz for Mobile/Fixed Communications Networks (MFCN)", Approved 27 June 2014, amended 10 March 2023.
- [i.23] [Commission Implementing Decision \(EU\) 2020/636 of 8 May 2020](#) amending Decision 2008/477/EC as regards an update of relevant technical conditions applicable to the 2500-2690 MHz frequency band.
- [i.24] [ECC Decision \(05\)05](#): "Harmonised utilization of spectrum for Mobile/Fixed Communications Networks (MFCN) operating within the band 2 500-2 690 MHz", Approved 18 March 2005, Amended 05 July 2019.
- [i.25] [ECC Decision \(11\)06](#): "Harmonised frequency arrangements and least restrictive technical conditions (LRTC) for mobile/fixed communications networks (MFCN) operating in the band 3400-3800 MHz", Approved 09 December 2011, Amended 26 October 2018.

- [i.26] [ECC Decision \(06\)09](#): "Designation of the bands 1980-2010 MHz and 2170-2200 MHz for use by systems in the Mobile-Satellite Service including those supplemented by a Complementary Ground Component (CGC)", Approved 01 December 2006, Amended 05 September 2007.
- [i.27] ETSI TR 137 941 (V15.3.0) (10-2021): "Universal Mobile Telecommunications System (UMTS); LTE; 5G; Radio Frequency (RF) conformance testing background for radiated Base Station (BS) requirements (3GPP TR 37.941 version 15.3.0 Release 15)".

3 Definition of terms, symbols and abbreviations

3.1 Terms

For the purposes of the present document, the following terms apply:

active antenna system base station: base station system which combines an Antenna Array with an Active transceiver unit array and a *Radio Distribution Network*

active transmitter unit: transmitter unit which is on, and has the ability to send modulated data streams, that are parallel and distinct to those sent from other transmitter units, to one or more *TAB connectors*

Band Category (BC): group of *operating bands* for which the same MSR scenarios apply

NOTE: The band categories for BS are defined in clause 4.4 of ETSI TS 137 141 [6] and are listed in table 1-1.

Base Station RF Bandwidth: RF bandwidth in which a base station transmits and/or receives single or multiple carrier(s) within a supported *operating band*

NOTE: In single carrier operation, the *Base Station RF Bandwidth* is equal to the *BS channel bandwidth*.

Base Station RF Bandwidth edge: frequency of one of the edges of the *Base Station RF Bandwidth*

basic limit: emissions limit relating to the power supplied by a single transmitter to a single antenna transmission line in Recommendation ITU-R SM.329-12 [i.4] used for the formulation of unwanted emission requirements

beam: main lobe of a radiation pattern from an AAS BS

NOTE: For certain AAS BS antenna array, there may be more than one *beam*.

beam centre direction: direction equal to the geometric centre of the half-power contour of the *beam*

beam direction pair: data set consisting of the *beam centre direction* and the related *beam peak direction*

beam peak direction: intended direction for maximum EIRP

beamwidth: *beam* which has a half-power contour that is essentially elliptical, the half-power beamwidths in the two pattern cuts that respectively contain the major and minor axis of the ellipse

BS class: classification of BS according to its intended use

NOTE: There are three BS classes in the present document:

- Wide Area Base Station;
- Medium Range Base Station; and
- Local Area Base Station.

BS receiver: composite receiver function of a BS receiving in an *operating band*

BS type 1-H: NR base station operating at FR1 with a requirement set consisting of conducted requirements defined for a group of *TAB connectors* and OTA requirements defined at RIB

BS type 1-O: NR base station operating at FR1 with a requirement set consisting only of OTA requirements defined at the RIB

carrier aggregation: aggregation of two or more NR or E-UTRA component carriers in order to support wider *transmission bandwidths*

carrier aggregation configuration: set of one or more *operating bands* across which the BS aggregates carriers with a specific set of technical requirements

channel bandwidth: RF bandwidth supporting a single RF carrier with the *transmission bandwidth* configured in the uplink or downlink of a cell

NOTE 1: The *channel bandwidth* is expressed in MHz and is used as a reference for transmitter and receiver RF requirements.

NOTE 2: For UTRA FDD, the *channel bandwidth* is the nominal channel spacing specified in ETSI TS 125 104 [10].

NOTE 3: For E-UTRA, the *channel bandwidths* are specified in ETSI TS 136 104 [9]. Standalone NB-IoT *channel bandwidths* specified in ETSI TS 136 104 [9] are not applicable to AAS BS.

NOTE 4: In ETSI TS 138 104 [13] for NR, *channel bandwidths* are referred to as *BS channel bandwidths*, since for NR BS and UE channel bandwidths may differ.

channel edge: lowest or highest frequency of a carrier, separated by the *BS channel bandwidth*

co-location test antenna: practical passive antenna that is used for conformance testing of the co-location requirements

NOTE: *Co-Location Test Antenna* (CLTA) is described in clause 4.15.2 in ETSI TS 137 145-2 [3].

contiguous carriers: set of two or more carriers configured in a spectrum block where there are no RF requirements based on co-existence for un-coordinated operation within the spectrum block

contiguous spectrum: spectrum consisting of a contiguous block of spectrum with no *sub-block gap(s)*

equivalent isotropic radiated power: equivalent power radiated from an isotropic directivity device producing the same field intensity at a point of observation as the field intensity radiated in the direction of the same point of observation by the discussed device

NOTE: Isotropic directivity is equal in all directions (0 dBi).

equivalent isotropic sensitivity: sensitivity for an isotropic directivity device equivalent to the sensitivity of the discussed device exposed to an incoming wave from a defined AoA

NOTE 1: The sensitivity is the minimum received power level at which a RAT specific requirement is met.

NOTE 2: Isotropic directivity is equal in all directions (0 dBi).

fractional bandwidth: fractional bandwidth FBW is defined in percent as $FBW = 200 \cdot \frac{F_{FBW_{high}} - F_{FBW_{low}}}{F_{FBW_{high}} + F_{FBW_{low}}} \%$

highest carrier: carrier with the highest carrier frequency transmitted/received in a specified frequency band

hybrid AAS BS: AAS BS which has ≥ 8 *transceiver units* for E-UTRA or MSR and ≥ 4 *transceiver units* for UTRA per cell has both a conducted RF interface and a radiated RF interface in the far field

NOTE: For NR operation, a *hybrid AAS BS* corresponds to NR BS *type I-H* in ETSI EN 301 908-24 [14].

inter-band carrier aggregation: *carrier aggregation* of component carriers in different *operating bands*

NOTE: Carriers aggregated in each band can be contiguous or non-contiguous.

inter-band gap: frequency gap between two supported consecutive *operating bands*

inter RF Bandwidth gap: frequency gap between two consecutive *Base Station RF Bandwidths* that are placed within two supported *operating bands*

intra-band contiguous carrier aggregation: *contiguous carriers* aggregated in the same *operating band*

intra-band non-contiguous carrier aggregation: non-contiguous carriers aggregated in the same *operating band*

local area Base Station: base station characterized by requirements derived from picocell scenarios with a BS to UE minimum coupling loss equal to 45 dB

lowest carrier: carrier with the lowest carrier frequency transmitted/received in a specified frequency band

NOTE: It is used as a frequency reference point for both transmitter and receiver requirements.

maximum carrier output power per TAB connector: mean power level measured on a particular carrier at the array boundary antenna connectors, during the *transmitter ON period* in a specified reference condition

maximum carrier TRP: mean power level measured per RIB during the *transmitter ON period* for a specific carrier in a specified reference condition and corresponding to the *rated carrier TRP* ($P_{\text{rated,c,TRP}}$)

maximum radio bandwidth: frequency difference between the upper edge of the highest used carrier and the lower edge of the lowest used carrier

measurement bandwidth: RF bandwidth in which an emission level is specified

medium range Base Station: Base Stations characterized by requirements derived from micro cell scenarios with a BS to UE minimum coupling loss equal to 53 dB

minSENS: lowest EIS value for the OSDD's associated with OTA sensitivity requirement

minSENS RoAoA: *reference RoAoA* associated with the OSDD with the lowest EIS value

MSR operation: operation of AAS BS as multi-standard radio in particular *operating band(s)*

NOTE: MSR operation is also possible in a single RAT configuration: UTRA, E-UTRA or NR.

multi-band requirements: requirements applying per one single *operating band* with exclusion bands or other multi-band provisions as defined for each requirement

multi-band RIB: *operating band* specific RIB associated with a transmitter or receiver that is characterized by the ability to process two or more carriers in common active RF components simultaneously, where at least one carrier is configured at a different *operating band* than the other carrier(s) and where this different *operating band* is not a sub-band or superseding-band of another supported *operating band*

multi-band TAB connector: *TAB connector* supporting operation in multiple *operating bands* through common active electronic component(s)

NOTE: For common TX and RX *TAB connectors*, the definition applies where common active electronic components are in the transmit path and/or in the receive path.

non-contiguous spectrum: spectrum consisting of two or more *sub-blocks* separated by *sub-block gap(s)*

operating band: frequency range in which the AAS BS operates (paired or unpaired), that is defined with a specific set of technical requirements

OTA AAS BS: AAS BS which has ≥ 8 *transceiver units* for E-UTRA or MSR and ≥ 4 *transceiver units* for UTRA per cell and has a radiated RF interface only and conforms to the *OTA requirements set*

NOTE: For NR operation, an *OTA AAS BS* corresponds to an NR *BS type 1-O* in ETSI EN 301 908-24 [14].

OTA coverage range: common range of directions within which TX OTA requirements that are neither specified in the *OTA peak directions sets* nor as TRP requirement are intended to be met

OTA peak directions set: set(s) of *beam peak directions* within which certain TX OTA requirements are intended to be met, where all *OTA peak directions set(s)* are subsets of the *OTA coverage range*

NOTE: The *beam peak directions* are related to a corresponding contiguous range or discrete list of *beam centre directions* by the *beam direction pairs* included in the set.

OTA REFSSENS RoAoA: RoAoA determined by the contour defined by the points at which the achieved EIS is 3 dB more than the achieved EIS in the reference direction

NOTE: This contour will be related to the average element/sub-array radiation pattern 3 dB *beamwidth*.

OTA sensitivity directions declaration: set of manufacturer declarations comprising at least one set of minimum EIS values (with *BS channel bandwidth*), and related directions over which the EIS applies

NOTE: All the directions apply to all the EIS values in an OSDD.

polarization match: condition that exists when a plane wave, incident upon an antenna from a given direction, has a polarization that is the same as the receiving polarization of the antenna in that direction

radiated interface boundary: *operating band* specific radiated requirements reference where the radiated requirements apply

NOTE: For requirements based on EIRP/EIS, the *radiated interface boundary* is associated to the far-field region.

radio distribution network: passive network which distributes radio signals generated by the transceiver unit array to the antenna array, and/or distributes the radio signals collected by the antenna array to the transceiver unit array

NOTE: In the case when the active transceiver units are physically integrated with the array elements of the antenna array, the radio distribution network is a one-to-one mapping.

rated beam EIRP: for a certain *beam* and *beam direction pair*, the *rated beam EIRP* level is the maximum power that the base station is intended to radiate at the associated *beam peak direction* during the *transmitter ON period*

rated carrier output power per TAB connector: mean power level associated with a particular carrier the manufacturer has declared to be available at the *TAB connector*, during the *transmitter ON period* in a specified reference condition

rated carrier TRP: mean power level per carrier, for BS operating in single carrier, multi-carrier, or *carrier aggregation* configurations that the manufacturer has declared to be available at the RIB during the *transmitter ON period*

rated total output power per TAB connector: mean power level associated with a particular *operating band* the manufacturer has declared to be available at the *TAB connector*, during the *transmitter ON period* in a specified reference condition

rated transmitter TRP: mean power level declared by the manufacturer to be available at the RIB *during* the *transmitter ON period*

receiver target: AoA in which reception is performed

NOTE: Only for *OTA AAS BS*.

receiver target redirection range: union of all the *sensitivity RoAoA* achievable through redirecting the *receiver target* related to a particular OSDD

receiver target reference direction: target direction inside the *OTA sensitivity directions declaration*

NOTE: For an OSDD without *receiver target redirection range*, this is a direction inside the *sensitivity RoAoA*.

reference beam direction pair: *beam direction pair*, including reference *beam centre direction* and reference *beam peak direction* where the reference *beam peak direction* is the direction for the intended maximum EIRP within the *OTA peak directions set*

reference RoAoA: sensitivity RoAoA associated with the *receiver target reference direction* for each OSDD

sensitivity RoAoA: RoAoA within the *OTA sensitivity directions declaration*, within which the EIS(s) of an OSDD is intended to be achieved at any instance of time for a specific AAS BS direction setting

single-band requirements: requirements applying per one single *operating band* without exclusion bands or other multi-band provisions

single-band RIB: *operating band* specific RIB supporting operation either in a single *operating band* only, or in multiple *operating bands* but does not meet the conditions for a *multi-band RIB*

single-band TAB connector: *TAB connector* supporting operation either in a single *operating band* only, or in multiple *operating bands* but without any common active electronic component(s)

single RAT E-UTRA operation: operation of AAS BS as single RAT E-UTRA in the *operating band*

single RAT UTRA operation: operation of AAS BS as single RAT UTRA in the *operating band*

sub-block: one contiguous allocated block of spectrum for transmission and reception by the same base station

NOTE: There may be multiple instances of *sub-blocks* within a *Base Station RF Bandwidth*.

sub-block gap: frequency gap between two consecutive *sub-blocks* within a *Base Station RF Bandwidth*, where the RF requirements in the gap are based on co-existence for un-coordinated operation

synchronized operation: operation of TDD in two different systems, where no simultaneous uplink and downlink occur

TAB connector: *transceiver array boundary* connector

TAB connector RX min cell group: operating band specific group of *TAB connectors* responsible for receiving a cell, associated with the intended minimum number of cells, N_{cells}

TAB connector TX min cell group: operating band specific group of *TAB connectors* responsible for transmitting a cell, associated with the intended minimum number of cells, N_{cells}

throughput: number of payload bits successfully received per second for a reference measurement channel in a specified reference condition

total radiated power: total power radiated by the antenna

NOTE: The *total radiated power* is the power radiating in all direction for two orthogonal polarizations. Total radiated power is defined in both the near-field region and the far-field region.

transceiver array boundary: conducted interface between the transceiver unit array and the composite antenna

transmission bandwidth: RF Bandwidth of an instantaneous transmission from a UE or BS, expressed in resource block units

NOTE: It is used as a frequency reference point for both transmitter and receiver requirements.

transmitter OFF period: time period during which the transmitter is scheduled not to transmit

NOTE: For AAS BS, this definition applies per *TAB connector* and *operating band*.

transmitter ON period: time period during which the transmitter is transmitting data and/or reference symbols

NOTE: For AAS BS, this definition applies per *TAB connector* and *operating band*.

transmitter transient period: time period during which the transmitter is changing from the OFF period to the ON period or vice versa

uplink operating band: part of the (FDD) *operating band* designated for uplink

wide area Base Station: Base Station characterized by requirements derived from Macro Cell scenarios with a BS to UE minimum coupling loss equal to 70 dB

3.2 Symbols

For the purposes of the present document, the following symbols apply:

$BeW_{\theta, \text{REFSENS}}$	The beamwidth equivalent to the OTA REFSENS RoAoA in the θ -axis in degrees
BW_{Channel}	Channel bandwidth (for E-UTRA or NR)
BW_{Config}	Transmission bandwidth configuration, expressed in MHz, where for E-UTRA $BW_{\text{Config}} = N_{\text{RB}} \times 180 \text{ kHz}$ in the uplink and $BW_{\text{Config}} = 15 \text{ kHz} + N_{\text{RB}} \times 180 \text{ kHz}$ in the downlink and for NR $BW_{\text{Config}} = N_{\text{RB}} \times \text{SCS} \times 12 \text{ kHz}$
Δf	Separation between the <i>Base Station RF bandwidth edge</i> frequency and the nominal -3 dB point of the measuring filter closest to the carrier frequency, expressed in MHz
Δf_{max}	The largest value of Δf used for defining the requirement, expressed in MHz
Δf_{OBUE}	Maximum offset of the <i>operating band unwanted emissions</i> mask from the downlink <i>operating band</i> , expressed in MHz

Δf_{OOB}	Maximum offset of the out-of-band boundary from the <i>uplink operating band</i> edge, expressed in MHz
$\Delta f_{\text{minSENS}}$	Difference between conducted reference sensitivity and EIS_{minSENS} and calculated in clause 4.3.1.6
$\Delta f_{\text{OTAREFSSENS}}$	Parameter calculated in clause 4.3.1.6 which represents the difference between conducted reference sensitivity and radiated reference sensitivity
Δf_{sample}	The difference between power measurements under normal and extreme test environments test environment, $P_{\text{max,sample,nom}} - P_{\text{max,sample,ex}}$
EIS_{minSENS}	The EIS value for the minSENS RoAoA
EIS_{REFSENS}	Radiated reference sensitivity EIS value
f	Frequency
f_{filter}	Filter centre frequency
f_{FBhigh}	Highest frequency within the <i>operating band</i> , for which <i>fractional bandwidth</i> support is supported, expressed in MHz
f_{FBlow}	Lowest frequency within the <i>operating band</i> , for which <i>fractional bandwidth</i> support is supported, expressed in MHz
f_{offset}	Separation between the <i>channel edge</i> frequency and the centre of the measuring filter, expressed in MHz
$f_{\text{offset, RAT}}$	Frequency offset from the centre frequency of the highest transmitted/received carrier to the upper <i>Base Station RF bandwidth edge</i> , <i>sub-block edge</i> or Inter RF bandwidth edge, or from the centre frequency of the lowest transmitted/received carrier to the lower <i>Base Station RF bandwidth edge</i> , <i>sub-block edge</i> or Inter RF bandwidth edge for a specific RAT
$f_{\text{offsetmax}}$	The offset to the frequency Δf_{OBUE} outside the downlink <i>operating band</i> , expressed in MHz
$f_{\text{DL_low}}$	The lowest frequency of the downlink <i>operating band</i> , expressed in MHz
$f_{\text{DL_high}}$	The highest frequency of the downlink <i>operating band</i> , expressed in MHz
$f_{\text{UL_low}}$	The lowest frequency of the <i>uplink operating band</i> , expressed in MHz
$f_{\text{UL_high}}$	The highest frequency of the <i>uplink operating band</i> , expressed in MHz
f_{uw}	Frequency offset of unwanted signal
I_{uant}	E-Node B internal logical interface between the implementation specific O&M function and the RET antennas and TMAs control unit function of the BS
N_{cells}	Minimum number of cells that can be transmitted by an AAS BS in a particular band with transmission on all transceiver units supporting the <i>operating band</i>
N_{RB}	Transmission bandwidth configuration, expressed in units of resource blocks (for E-UTRA)
$N_{\text{TXU, active}}$	The number of <i>active transmitter units</i>
$N_{\text{TXU,counted}}$	The number of <i>active transmitter units</i> that are taken into account for conducted TX output power limit and for unwanted TX emissions scaling
$N_{\text{TXU,countedpercell}}$	The number of <i>active transmitter units</i> that are taken into account for conducted TX emissions scaling per cell
P_{cell}	Primary cell
$P_{\text{max,c,cell}}$	The <i>maximum carrier output power per TAB connector TX min cell group</i>
$P_{\text{max,c,TABC}}$	The <i>maximum carrier output power per TAB connector</i>
$P_{\text{max,sample,nom}}$	The measured sample power in the environmental enclosure when the AAS BS is configured at the <i>rated carrier TRP</i> ($P_{\text{rated,c,TRP}}$), under normal test environment
$P_{\text{max,sample,ext}}$	The measured sample power in the environmental enclosure when the AAS BS is configured at the <i>rated carrier TRP</i> ($P_{\text{rated,c,TRP}}$), under extreme test environment
$P_{\text{max,c,EIRP}}$	The maximum carrier EIRP when the AAS BS is configured at the <i>rated carrier TRP</i> ($P_{\text{rated,c,TRP}}$)
$P_{\text{max,c,EIRP, extreme}}$	The maximum carrier EIRP when the AAS BS is configured at the <i>rated carrier TRP</i> ($P_{\text{rated,c,TRP}}$) under extreme test environment, either measured directly or calculated
$P_{\text{max,c,TRP}}$	The maximum carrier TRP per cell
$P_{\text{max,t,TRP}}$	the maximum total output power per cell
$P_{\text{rated,c,cell}}$	The <i>rated carrier output power per TAB connector TX min cell group</i>
$P_{\text{rated,c,EIRP}}$	The rated carrier EIRP when the AAS BS is configured at the <i>rated carrier TRP</i> ($P_{\text{rated,c,TRP}}$)
$P_{\text{rated,c,FBhigh}}$	The rated carrier EIRP for the higher frequency range within the <i>operating band</i> , for which fractional bandwidth is supported
$P_{\text{rated,c,FBlow}}$	The rated carrier EIRP for the lower frequency range within the <i>operating band</i> , for which fractional bandwidth is supported
$P_{\text{rated,c,TABC}}$	The <i>rated carrier output power per TAB connector</i>
$P_{\text{rated,t,TABC}}$	The <i>rated total output power per TAB connector</i>
$P_{\text{rated,c,TRP}}$	The <i>rated carrier TRP</i>
$P_{\text{rated,t,TRP}}$	<i>Rated transmitter TRP</i> per RIB
P_{REFSENS}	Conducted reference Sensitivity power level
W_{gap}	Sub-block gap or Inter RF Bandwidth gap size

3.3 Abbreviations

For the purposes of the present document, the following abbreviations apply:

AAS BS	Active Antenna System Base Station
AAS	Active Antenna System
ACLR	Adjacent Channel Leakage power Ratio
ACS	Adjacent Channel Selectivity
AoA	Angle of Arrival
ARFCN	Absolute Radio Frequency Channel Number
B	Bottom RF channel (for testing purposes)
BC	Band Category
BER	Bit Error Rate
BS	Base Station
BW	Bandwidth
CA	Carrier Aggregation
CACLR	Cumulative ACLR
CDMA	Code Division Multiple Access
CLTA	Co-Location Test Antenna
CW	Continuous Wave (unmodulated signal)
DL	Downlink
DPCH	Dedicated Physical Channel
DTT	Digital Terrestrial Television
EARFCN	E-UTRA Absolute Radio Frequency Channel Number
EC	European Commission
EDGE	EDGE Enhanced Data for GSM Evolution
EFTA	European Foreign Trade Association
EG	ETSI Guide
EIRP	Equivalent Isotropic Radiated Power
EIS	Equivalent Isotropic Sensitivity
EUT	Equipment Under Test
E-UTRA	Evolved UMTS Terrestrial Radio Access
FBW	Fractional Bandwidth
FDD	Frequency Division Duplex
FR1	Frequency Range 1
FRC	Fixed Reference Channel
FS	Fixed Services
FSS	Fixed Satellite Services
GMSK	Gaussian Minimum Shift Keying
GSM	Global System for Mobile communication
HARQ	Hybrid Automatic Repeat-reQuest
IMT	International Mobile Telecommunications
ITU-R	International Telecommunication Union - Radio
M	Middle RF channel (for testing purposes)
MC	Multi-Carrier in a Single RAT
MS	Mobile Station
MSG	Mobile Standards Group (ETSI TC)
MSR	Multi-Standard Radio
NB-IoT	Narrowband - Internet of Things
NR	New Radio
OBUE	Operating Band Unwanted Emissions
OSDD	OTA Sensitivity Directions Declaration
OTA	Over-The-Air
RAT	Radio Access Technology
RB	Resource Block (for E-UTRA)
RDN	Radio Distribution Network
REFSENS	Reference Sensitivity
RET	Remote Electrical Tilt
RF	Radio Frequency
RIB	Radiated Interface Boundary
RMS	Root Mean Square (value)

RoAoA	Range of Angles of Arrival
RRC	Root Raised Cosine
RX	Receiver
SC	Single Carrier
SCS	Sub-Carrier Spacing
SEM	Spectrum Emission Mask
TAB	Transceiver Array Boundary
TDD	Time Division Duplex
TR	Technical Report
TRP	Total Radiated Power
TS	Technical Specifications
TX	Transmitter
UARFCN	UTRA Absolute Radio Frequency Channel Number
UE	User Equipment
UL	Uplink
UMTS	Universal Mobile Telecommunications System
UTRA	UMTS Terrestrial Radio Access
WCDMA	Wide band Code Division Multiple Access

4 Technical requirements specifications

4.1 Environmental profile

The technical requirements of the present document apply under the environmental profile for operation of the equipment, which shall be in accordance with its intended use. The equipment shall comply with all the technical requirements of the present document at all times when operating within the boundary limits of the operational environmental profile defined by its intended use.

The operational environmental profile shall at least contain all environmental conditions in the test environments referenced from the essential radio test suites in clause 5 of the present document.

4.2 Requirement set applicability

Table 4.2-1 provides a summary of the BS *requirement set* applicability, depending on the BS type, i.e. *Hybrid AAS BS* or *OTA AAS BS*

Table 4.2-1: Requirement set applicability

Requirement	Requirement set (by clause)	
	AAS BS type	
	Hybrid	OTA
Operating band unwanted emissions	4.3.2	
Spectrum Emission Mask (SEM)	4.3.3	
Adjacent Channel Leakage power Ratio (ACLR)	4.3.4	
Transmitter spurious emissions	4.3.5	
BS maximum output power	4.3.6	
Transmitter intermodulation	4.3.7	
Receiver spurious emissions	4.3.8	
Blocking	4.3.9	
Receiver intermodulation	4.3.10	
Adjacent Channel Selectivity (ACS)	4.3.11	
Reference sensitivity level	4.3.12	
OTA operating band unwanted emissions		4.3.13
OTA SEM		4.3.14
OTA ACLR		4.3.15
OTA transmitter spurious emissions		4.3.16
Radiated transmit power	4.3.17	4.3.17
OTA Maximum output power		4.3.18
OTA transmitter intermodulation		4.3.19
OTA receiver spurious emissions		4.3.20

Requirement AAS BS type	Requirement set (by clause)	
	Hybrid	OTA
OTA blocking		4.3.21
OTA receiver intermodulation		4.3.22
OTA ACS		4.3.23
OTA sensitivity	4.3.24	4.3.24
OTA reference sensitivity level		4.3.25

4.3 Conformance requirements

4.3.1 Introduction

4.3.1.1 General

The requirements in the present document are based on the assumption that the *operating bands* (see table 1-1) could be shared between systems of the IMT family or systems having compatible characteristics.

To meet the essential requirement under article 3.2 of Directive 2014/53/EU [i.2] for IMT Base Stations (BS), a set of essential parameters in addition to those in ETSI EN 301 908-1 [i.6] have been identified. Tables 4.3.1.1-1 and 4.3.1.1-2 provide a cross reference between these additional essential parameters and the corresponding conducted technical requirements for equipment within the scope of the present document.

NOTE 1: A more detailed argumentation is included in the ETSI TR 103 877 [i.7].

Table 4.3.1.1-1: Cross references for conducted requirements and test suites

Essential parameter	Corresponding conducted technical requirements	Corresponding conducted test suite
Transmitter spectrum mask	4.3.2 Operating band unwanted emissions	5.3.2
Transmitter unwanted emissions in the out-of-band domain	4.3.3 Spectrum emission mask	5.3.3
	4.3.4 Adjacent channel leakage power ratio	5.3.4
Transmitter unwanted emissions in the spurious domain	4.3.5 Transmitter spurious emissions	5.3.5
Transmitter power accuracy	4.3.6 Base station maximum output power	5.3.6
Transmitter intermodulation attenuation	4.3.7 Transmit intermodulation	5.3.7
Receiver unwanted emissions in the spurious domain	4.3.8 Receiver spurious emissions	5.3.8
Receiver blocking	4.3.9 Blocking	5.3.9
Receiver desensitization		
Receiver radio-frequency intermodulation	4.3.10 Receiver intermodulation	5.3.10
Receiver adjacent signal selectivity	4.3.11 Adjacent channel selectivity and narrowband blocking	5.3.11
Receiver sensitivity	4.3.12 Reference sensitivity level	5.3.12

Table 4.3.1.1-2: Cross references for radiated (OTA) requirements and test suites

Essential parameter	Corresponding radiated technical requirements	Corresponding radiated test suite
Transmitter spectrum mask	4.3.13 OTA Operating band unwanted emissions	5.3.13 5.3.14
Transmitter unwanted emissions in the out-of-band domain	4.3.14 OTA Spectrum emission mask 4.3.15 OTA Adjacent channel leakage power ratio	5.3.15
Transmitter unwanted emissions in the spurious domain	4.3.16 OTA transmitter spurious emissions	5.3.16
Transmitter power accuracy	4.3.17 Radiated transmit power 4.3.18 OTA Maximum output power	5.3.17 5.3.18
Transmitter intermodulation attenuation	4.3.19 OTA transmitter intermodulation	5.3.19
Receiver unwanted emissions in the spurious domain	4.3.20 OTA spurious emissions	5.3.20
Receiver blocking	4.3.21 OTA blocking	5.3.21
Receiver desensitization		
Receiver radio-frequency intermodulation	4.3.22 OTA receiver intermodulation	5.3.22
Receiver adjacent signal selectivity	4.3.23 OTA adjacent channel selectivity	5.3.23
Receiver sensitivity	4.3.24 OTA sensitivity 4.3.25 OTA reference sensitivity level	5.3.24 5.3.25

For each BS Type and associated set of requirements, the limits are identified based on following information included in the technical documentation of the radio equipment:

- The intended *BS class* of the base station under test, according to:
 - clause 4.3 of ETSI TS 137 145-1 [2] for *Hybrid AAS BS*;
 - clause 4.3 of ETSI TS 137 145-2 [3] for *OTA AAS BS*.
- The supported RF configurations, according to:
 - clause 4.10 of ETSI TS 137 145-1 [2]; or
 - clause 4.10 of ETSI TS 137 145-2 [3].

AAS BS requirements are defined for two points of reference, signified by radiated requirements and conducted requirements.

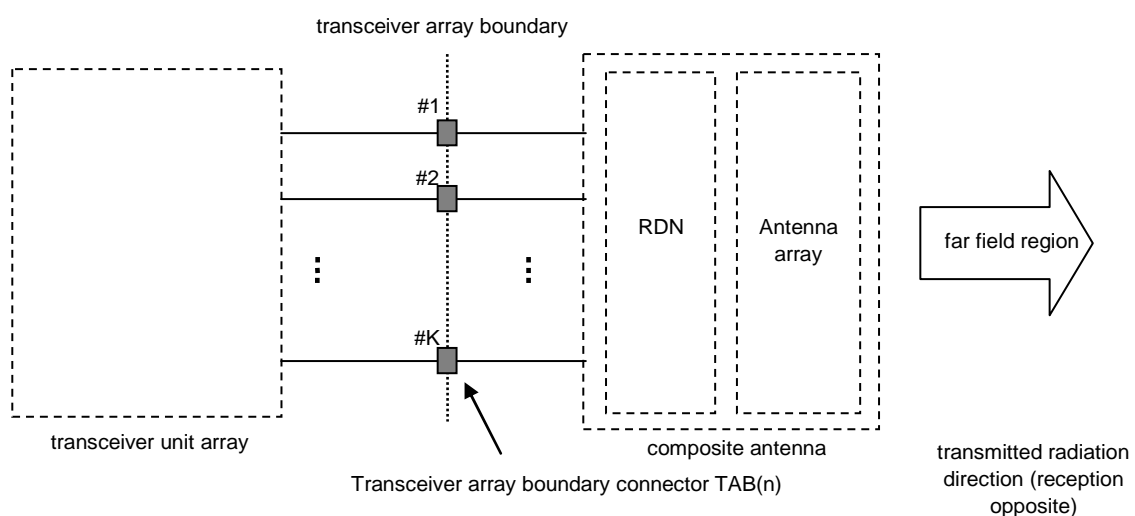
**Figure 4.3.1.1-1: Radiated and conducted points of reference of AAS BS**

Radiated characteristics are defined Over-The-Air (OTA) with a point of reference in the far field (Fraunhofer) region. Radiated requirements are also referred to as OTA requirements.

Conducted characteristics are defined at individual or groups of *TAB connectors* at the *transceiver array boundary*, which is the conducted interface between the transceiver unit array and the composite antenna.

The transceiver unit array is part of the composite transceiver functionality generating modulated transmit signal structures and performing receiver combining and demodulation.

The transceiver unit array contains an implementation specific number of transmitter units and an implementation specific number of receiver units. Transmitter units and receiver units may be combined into transceiver units. The transmitter/receiver units have the ability to receive/send parallel independent modulated symbol streams.

The composite antenna contains a *Radio Distribution Network (RDN)* and an antenna array. The RDN is a linear passive network that distributes the RF power between the *transceiver array boundary* and the antenna array, in an implementation specific way.

The technical requirements in the present document apply for the *BS class* and the supported *operating band(s)* as outlined for each requirement. For a Base Station supporting more than one *operating band*, compliance to each technical requirement in clause 4 shall be fulfilled for each *operating band*.

All technical requirements shall apply with a frequency offset from the *lowest-* and *highest carrier* frequencies transmitted or received in the specified *operating band* to the *Base Station RF bandwidth edges* ($F_{\text{offset, RAT}}$) that is specific for each RAT in each *Band Category* as defined in clause 4.4 of ETSI TS 137 141 [6].

The technical requirements also apply to the BS configurations described in clauses C.3, C.4, D.3 and D.4 of the present document.

NOTE 2: Additional requirements arising from EC/CEPT spectrum regulatory framework that apply to specific equipment applicable to specific cases in certain countries and/or in certain geographical areas are addressed in ETSI TS 103 807 [i.9].

All the parameters declared by the manufacturer shall correspond to the intended use of the equipment. Throughout the present document there are such references to manufacturer declarations. They are referred as Dn.x and will be coded in the following manner, in order to distinguish their origin:

- All parameters in the form D6.x in clauses 4.3.2 to 4.3.12, 5.3.2 to 5.3.12 and annex C are found in clause 4.10 in ETSI TS 137 145-1 [2].
- All parameters in the form D9.x in clauses 4.3.13 to 4.3.25 and 5.3.13 to 5.3.25 are found in clause 4.10 in ETSI TS 137 145-2 [3].

4.3.1.2 Conducted transmitter requirements

Unwanted emissions consist of out-of-band emissions and spurious emissions according to ITU definitions in Recommendation ITU-R SM.329-12 [i.4]. In ITU terminology, out of band emissions are unwanted emissions immediately outside the *BS channel bandwidth* resulting from the modulation process and non-linearity in the transmitter, but excluding spurious emissions. Spurious emissions are emissions which are caused by unwanted transmitter effects such as harmonics emission, parasitic emission, intermodulation products and frequency conversion products, but exclude out of band emissions. The out-of-band emissions requirement for the BS transmitter is specified in terms of:

- Adjacent Channel Leakage power Ratio (ACLR) for E-UTRA, MSR and NR;
- Spectrum Emission Mask (SEM) for UTRA;
- Operating Band Unwanted Emissions (OBUE) for E-UTRA, MSR and NR.

The maximum offset of the OBUE mask from the *operating band* edge is Δf_{OBUE} . The OBUE define all unwanted emissions in each supported downlink *operating band* plus the frequency ranges Δf_{OBUE} above and Δf_{OBUE} below each band. Unwanted emissions outside of this frequency range are limited by a spurious emissions requirement.

The unwanted emission requirements apply per *TAB connector TX min cell group* for all the configurations supported by the *Hybrid AAS BS*. The emissions *basic limits* and respective scaling are defined in each relevant clause.

NOTE 1: The term "scaling" (i.e. of a basic limit) refers to how the limit is derived from the *basic limit* by adding X (dB) to scale with the number of active transmitters, $X = 10 \log_{10}(N_{\text{TXU, counted per cell}})$.

The number of *active transmitter units* that are considered when calculating the emissions limit ($N_{\text{TXU, counted}}$) for a *Hybrid AAS BS* is calculated as follows:

- $N_{\text{TXU, counted}} = \min(N_{\text{TXU, active}}, 8 \times N_{\text{cells}})$ for AAS BS supporting only single E-UTRA and AAS BS supporting MSR, except MSR operating in UTRA only; and
- $N_{\text{TXU, counted}} = \min(N_{\text{TXU, active}}, 4 \times N_{\text{cells}})$ for AAS BS supporting only single RAT UTRA and AAS BS supporting MSR operating in UTRA only.

Further:

- $N_{\text{TXU, counted per cell}} = N_{\text{TXU, counted}} / N_{\text{cells}}$
- $N_{\text{TXU, counted per cell}}$ is used for scaling the *basic limits*

NOTE 2: $N_{\text{TXU, active}}$ depends on the actual number of *active transmitter units* and is independent of N_{cells} .

4.3.1.3 Conducted receiver requirements

Conducted receiver characteristics are specified at the AAS BS *TAB connector*, in normal operation.

The following arrangements apply for conducted receiver requirements in clause 4.3:

- Requirements apply during the BS receive period.
- Requirements shall apply for any transmitter setting.
- For FDD operation the requirements shall apply with the transmitter unit(s) transmitting data and/or reference symbols.
- *Throughput* requirements defined for the receiver characteristics do not assume HARQ retransmissions.
- When BS is configured to receive multiple carriers, all the *throughput* requirements are applicable for each received carrier.
- For ACS, blocking and intermodulation characteristics, the negative offsets of the interfering signal apply relative to the lower *Base Station RF Bandwidth edge* or *sub-block edge* inside a *sub-block gap*, and the positive offsets of the interfering signal apply relative to the upper *Base Station RF Bandwidth edge* or *sub-block edge* inside a *sub-block gap*.

4.3.1.4 Conducted requirements for BS capable of multi-band operation

For *multi-band TAB connectors* the conducted limits in clause 4 shall apply separately to each supported *operating band*. For some conducted limits, it is explicitly stated that specific additions or exclusions to the requirement apply at *multi-band TAB connector(s)* as detailed in the requirement clause.

A *Hybrid AAS BS* may be capable of supporting operation in multiple *operating bands* with one of the following implementations of *TAB connectors* in the *transceiver array boundary*:

- All TAB connectors are single band TAB connectors:
 - Different sets of *single band TAB connectors* support different *operating bands*, but each *TAB connector* supports only operation in one single *operating band*.
 - Sets of single band TAB connectors support operation in multiple operating bands with some single band TAB connectors supporting more than one *operating band*.
- All TAB connectors are multi-band TAB connectors.
- A combination of single band sets and multi-band sets of *TAB connectors* provides support of the AAS BS capability of operation in multiple *operating bands*.

All requirements specified for an *operating band* shall apply only to the set of *TAB connectors* supporting that *operating band*.

In the case of an *operating band* being supported only by *single band TAB connectors* in a *TAB connector TX min cell group* or a *TAB connector RX min cell group*, *single band requirements* shall apply to that set of *TAB connectors*.

NOTE 1: Each supported *operating band* needs to be enabled separately during conformance testing on *single band TAB connectors*.

For a band supported by a *TAB connector* where the transmitted carriers are not processed in active RF components together with carriers in any other band, TX single band requirements shall apply. For a band supported by a *TAB connector* where the received carriers are not processed in active RF components together with carriers in any other band, RX single band requirements shall apply.

In the case of an *operating band* being supported only by *multi-band TAB connectors* supporting the same *operating band* combination in a *TAB connector TX min cell group* or a *TAB connector RX min cell group*, *multi-band requirements* shall apply to that set of *TAB connectors*.

For *multi-band TAB connectors* supporting the bands for TDD, the RF requirements in the present specification assume no simultaneous uplink and downlink occur between the bands.

NOTE 2: The case of an *operating band* being supported by both *multi-band TAB connectors* and *single-band TAB connectors* in a *TAB connector TX min cell group* or a *TAB connector RX min cell group* is not covered by the present document.

NOTE 3: The case of an *operating band* being supported by *multi-band TAB connectors* which are not all supporting the same *operating band* combination in a *TAB connector TX min cell group* or a *TAB connector RX min cell group* is not covered by the present document.

NOTE 4: The limits for *multi-band TAB connectors* supporting bands for both FDD and TDD are not covered by the present document.

4.3.1.5 Radiated transmitter requirements

OTA unwanted emissions consist of so-called out-of-band emissions and spurious emissions according to ITU definitions in Recommendation ITU-R SM.329-12 [i.4]. In ITU terminology, out of band emissions are unwanted emissions immediately outside the *BS channel bandwidth* resulting from the modulation process and non-linearity in the transmitter but excluding spurious emissions. Spurious emissions are emissions which are caused by unwanted transmitter effects such as harmonics emission, parasitic emission, intermodulation products and frequency conversion products, but exclude out of band emissions.

The OTA out-of-band emissions requirement is specified in terms of:

- Adjacent Channel Leakage power Ratio (ACLR) for E-UTRA, NR and MSR;
- Spectrum Emission Mask (SEM) for UTRA;
- *Operating Band Unwanted Emissions* (OBUE) for E-UTRA, NR and MSR.

The OTA *Operating band unwanted emissions* define all unwanted emissions in each supported downlink *operating band* plus the frequency ranges Δf_{OBUE} above and Δf_{OBUE} below each band. OTA Unwanted emissions outside of this frequency range are limited by an OTA spurious emissions requirement.

The maximum offset of the *operating band unwanted emissions* mask from the *operating band* edge is Δf_{OBUE} .

The OTA unwanted emission requirements are applied per cell for all the configurations.

4.3.1.6 Radiated receiver requirements

The following arrangements apply for radiated receiver characteristics requirements:

- Requirements apply during the BS receive period.
- Requirements shall apply for any transmitter setting.
- For FDD operation the requirements shall apply with the transmitter unit(s) transmitting data and/or reference symbols.

- *Throughput* requirements defined for the radiated receiver characteristics do not assume HARQ retransmissions.
- When BS is configured to receive multiple carriers, all the *throughput* requirements are applicable for each received carrier.
- For ACS, blocking and intermodulation characteristics, the negative offsets of the interfering signal apply relative to the lower *Base Station RF Bandwidth edge* or *sub-block edge* inside a *sub-block gap*, and the positive offsets of the interfering signal apply relative to the upper *Base Station RF Bandwidth edge* or *sub-block edge* inside a *sub-block gap*.

Each radiated requirement, except OTA receiver spurious emissions, shall apply over the RoAoA specified.

Radiated requirements which apply over the *OTA REFSENS RoAoA* absolute limits are offset by the following term:

$$\Delta_{\text{OTAREFSENS}} = 44,1 - 10 \times \log_{10}(\text{BeW}_{\theta, \text{REFSENS}} \times \text{BeW}_{\phi, \text{REFSENS}}) \text{ (dB) for the reference direction;}$$

and

$$\Delta_{\text{OTAREFSENS}} = 41,1 - 10 \times \log_{10}(\text{BeW}_{\theta, \text{REFSENS}} \times \text{BeW}_{\phi, \text{REFSENS}}) \text{ (dB) for all other directions.}$$

For requirements which apply over the *minSENS RoAoA* absolute limits are offset by the following term:

$$\Delta_{\text{minSENS}} = \text{P}_{\text{REFSENS}} - \text{EIS}_{\text{minSENS}} \text{ (dB)}$$

4.3.1.7 Radiated requirements for BS capable of multi-band operation

For *multi-band RIB*, the radiated limits in clause 4 apply separately to each supported *operating band*. For some radiated limits, it is explicitly stated that specific additions or exclusions to the limit apply at *multi-band RIB(s)* as detailed in the requirement clause.

OTA AAS BS may be capable of supporting operation in multiple *operating bands* with one of the following implementations at the *radiated interface boundary*:

- All RIBs are single-band RIBs.
- All RIBs are multi-band RIBs.
- A combination of single-band RIBs and multi-band RIBs provides support of the *OTA AAS BS* capability of operation in multiple operating bands.

A RIB may operate multi-RAT where the individual RATs are operated in different RAT specific bands that partially or fully overlap; Δf_{OBUE} and Δf_{OOB} are according to the combined frequency range occupied by the overlapping bands.

For *multi-band RIBs* supporting the bands for TDD, the radiated limits in the present specification assume no simultaneous uplink and downlink occur between the bands.

NOTE: The radiated limits for *multi-band RIBs* supporting bands for both FDD and TDD are not covered by the present document.

4.3.2 Operating Band Unwanted Emissions (OBUE)

4.3.2.1 Definition and applicability

The *Operating Band Unwanted Emission* (OBUE) limits for E-UTRA single band and MSR are defined from Δf_{OBUE} below the lowest frequency of each supported *downlink operating band* to the lower *Base Station RF Bandwidth edge* located at $F_{\text{BW RF,low}}$ and from the upper *Base Station RF Bandwidth edge* located at $F_{\text{BW RF,high}}$ up to Δf_{OBUE} above the highest frequency of each supported *downlink operating band*. The values of Δf_{OBUE} are defined in table 4.3.2.1-1.

For AAS BS capable of operation in multiple *operating bands*, using *single band TAB connectors*, the single-band requirements apply to those connectors and the cumulative evaluation of the emission limit in the *inter RF bandwidth gap* is not applicable.

The requirements shall apply whatever the type of transmitter considered and for all transmission modes foreseen by the manufacturer's specification.

Table 4.3.2.1-1: Maximum offset of OBUE outside the downlink operating band

BS type	Operating band characteristics	Δf_{OBUE} [MHz]
Hybrid AAS BS	$F_{\text{DL_high}} - F_{\text{DL_low}} < 100$ MHz	10
	$100 \text{ MHz} \leq F_{\text{DL_high}} - F_{\text{DL_low}} \leq 900$ MHz	40

Measurement filter is defined as in Recommendation ITU-R SM.329-12 [i.4], section 4.1.

In the following clauses the numerical values for f_{offset} , Δf , Δf_{OBUE} and Δf_{max} shall be expressed in MHz.

4.3.2.2 Limits

4.3.2.2.1 Limits for MSR operation

4.3.2.2.1.1 General

The *operating band unwanted emission* requirements for an AAS BS are that for each *TAB connector TX min cell group* and each applicable *basic limit*, the power summation of the emissions at the *TAB connectors* of the *TAB connector TX min cell group* shall not exceed a limit specified as the *basic limit* + $10\log_{10}(N_{\text{TXU, counted per cell}})$.

4.3.2.2.1.2 Basic limits for Band Categories 1 and 3

For *TAB connectors* operating in Band Category 1 or Band Category 3 the requirement applies outside the *Base Station RF Bandwidth edges*. In addition:

- For an AAS BS operating in *non-contiguous spectrum*, it applies inside any *sub-block gap*.
- For an AAS BS operating in multiple bands, the requirements apply inside any *Inter RF Bandwidth gap*.

Outside the *Base Station RF Bandwidth edges*, *basic limits* are specified in tables below, where:

- Δf is the separation between the *Base Station RF Bandwidth edge* frequency and the nominal -3 dB point of the measuring filter closest to the carrier frequency.
- f_{offset} is the separation between the *Base Station RF Bandwidth edge* frequency and the centre of the measuring filter.
- $f_{\text{offset}_{\text{max}}}$ is the offset to the frequency Δf_{OBUE} outside the *downlink operating band*.
- Δf_{max} is equal to $f_{\text{offset}_{\text{max}}}$ minus half of the bandwidth of the measuring filter.

For *multi-band TAB connectors*, inside any *Inter RF Bandwidth gaps* with $W_{\text{gap}} < 2 \times \Delta f_{\text{OBUE}}$ MHz, a combined *basic limit* shall be applied which is the cumulative sum of emissions shall not exceed the cumulative sum of the *basic limits* specified at the *Base Station RF Bandwidth edges* on each side of the *Inter RF Bandwidth gap*. The *basic limit* for *Base Station RF Bandwidth edge* is specified in tables below, where in this case:

- Δf is the separation between the *Base Station RF Bandwidth edge* frequency and the nominal -3 dB point of the measuring filter closest to the carrier frequency.
- f_{offset} is the separation between the *Base Station RF Bandwidth edge* frequency and the centre of the measuring filter.
- $f_{\text{offset}_{\text{max}}}$ is equal to the *inter RF Bandwidth gap* minus half of the bandwidth of the measuring filter.
- Δf_{max} is equal to $f_{\text{offset}_{\text{max}}}$ minus half of the bandwidth of the measuring filter.

For *multi-band TAB connectors*, the *operating band unwanted emission basic limits* apply also in a supported *operating band* without any carriers transmitted, in the case where there are carriers transmitted in another *operating band*. In this case where there is no carrier transmitted in an *operating band*, no cumulative *basic limits* are applied in the *inter-band gap* between a supported downlink band with carrier(s) transmitted and a supported downlink band without any carrier transmitted and:

- In case the *Inter RF Bandwidth gap* between a supported downlink band with carrier(s) transmitted and a supported downlink band without any carrier transmitted is less than $2 \times \Delta f_{\text{OBUE}}$, $f_{\text{offset}_{\text{max}}}$ shall be the offset to the frequency Δf_{OBUE} outside the outermost edges of the two supported *downlink operating bands* and the *operating band unwanted emission basic limit* of the band where there are carriers transmitted, as defined in the tables of the present clause, shall apply across both supported downlink bands.
- In other cases, the *operating band unwanted emission basic limit* of the band where there are carriers transmitted, as defined in the tables of the present clause for the largest frequency offset (Δf_{max}), shall apply from Δf_{OBUE} below the lowest frequency, up to Δf_{OBUE} above the highest frequency of the supported *downlink operating band* without any carrier transmitted.

For a multicarrier *single-band connector* or a *single-band connector* configured for intra-band contiguous or non-contiguous carrier aggregation, the definitions above apply to the lower edge of the carrier transmitted at the lowest carrier frequency and the upper edge of the carrier transmitted at the highest carrier frequency within a specified frequency band.

Inside any *sub-block gap* for *TAB connectors* operating in *non-contiguous spectrum*, a combined *basic limit* shall be applied which is the cumulative sum of the *basic limits* specified for the adjacent sub-blocks on each side of the *sub-block gap*. The *basic limit* for each sub-block is specified in tables below, where in this case:

- Δf is the separation between the sub-block edge frequency and the nominal -3 dB point of the measuring filter closest to the sub-block edge.
- f_{offset} is the separation between the sub-block edge frequency and the centre of the measuring filter.
- $f_{\text{offset}_{\text{max}}}$ is equal to the *sub-block gap* bandwidth minus half of the bandwidth of the measuring filter.
- Δf_{max} is equal to $f_{\text{offset}_{\text{max}}}$ minus half of the bandwidth of the measuring filter.

Table 4.3.2.1.2-1: Wide Area BS operating band unwanted emissions limits for BC1 and BC3 for bands ≤ 3 GHz except those covered by tables 4.3.2.1.2-2a and 4.3.2.1.2-2b

Frequency offset of measurement filter -3 dB point, Δf	Frequency offset of measurement filter centre frequency, f_{offset}	<i>basic limit</i> (notes 1 and 2)	<i>Measurement bandwidth</i>
$0 \text{ MHz} \leq \Delta f < 0,2 \text{ MHz}$	$0,015 \text{ MHz} \leq f_{\text{offset}} < 0,215 \text{ MHz}$	-12,5 dBm	30 kHz
$0,2 \text{ MHz} \leq \Delta f < 1 \text{ MHz}$	$0,215 \text{ MHz} \leq f_{\text{offset}} < 1,015 \text{ MHz}$	$-12,5 - 15 \times (f_{\text{offset}} - 0,215) \text{ dBm}$	30 kHz
(note 3)	$1,015 \text{ MHz} \leq f_{\text{offset}} < 1,5 \text{ MHz}$	-24,5 dBm	30 kHz
$1 \text{ MHz} \leq \Delta f \leq \min(\Delta f_{\text{max}}, 10 \text{ MHz})$	$1,5 \text{ MHz} \leq f_{\text{offset}} < \min(f_{\text{offset}_{\text{max}}}, 10,5 \text{ MHz})$	-11,5 dBm	1 MHz
$10 \text{ MHz} \leq \Delta f \leq \Delta f_{\text{max}}$	$10,5 \text{ MHz} \leq f_{\text{offset}} < f_{\text{offset}_{\text{max}}}$	-15 dBm (note 4)	1 MHz
NOTE 1: For <i>TAB connectors</i> supporting <i>non-contiguous spectrum</i> operation within any <i>operating band</i> the <i>basic limit</i> within <i>sub-block gaps</i> is calculated as a cumulative sum of contributions from adjacent sub-blocks on each side of the <i>sub-block gap</i> , where the contribution from the far-end sub-block shall be scaled according to the measurement bandwidth of the near-end sub-block. Exception is $\Delta f \geq 10$ MHz from both adjacent sub-blocks on each side of the <i>sub-block gap</i> , where the <i>basic limit</i> within <i>sub-block gaps</i> shall be -15 dBm/MHz.			
NOTE 2: For <i>multi-band TAB connectors</i> with <i>Inter RF Bandwidth gap</i> $< 2 \times \Delta f_{\text{OBUE}}$ MHz the <i>basic limit</i> within the <i>Inter RF Bandwidth gaps</i> is calculated as a cumulative sum of contributions from adjacent <i>sub-blocks</i> on each side of the <i>Inter RF Bandwidth gap</i> , where the contribution from the far-end sub-block or <i>Base Station RF Bandwidth</i> shall be scaled according to the measurement bandwidth of the near-end sub-block or <i>Base Station RF Bandwidth</i> .			
NOTE 3: This frequency range ensures that the range of values of f_{offset} is continuous.			
NOTE 4: The requirement is not applicable when $\Delta f_{\text{max}} < 10$ MHz.			

Table 4.3.2.2.1.2-2: Wide Area BS operating band unwanted emissions limits for BC1 and BC3 for bands > 3 GHz except those covered by table 4.3.2.2.1.2-2c

Frequency offset of measurement filter -3 dB point, Δf	Frequency offset of measurement filter centre frequency, f_{offset}	<i>basic limit</i> (notes 1 and 2)	<i>Measurement bandwidth</i>
$0 \text{ MHz} \leq \Delta f < 0,2 \text{ MHz}$	$0,015 \text{ MHz} \leq f_{\text{offset}} < 0,215 \text{ MHz}$	-12,2 dBm	30 kHz
$0,2 \text{ MHz} \leq \Delta f < 1 \text{ MHz}$	$0,215 \text{ MHz} \leq f_{\text{offset}} < 1,015 \text{ MHz}$	$-12,2 - 15 \times (f_{\text{offset}} - 0,215) \text{ dBm}$	30 kHz
(note 3)	$1,015 \text{ MHz} \leq f_{\text{offset}} < 1,5 \text{ MHz}$	-24,2 dBm	30 kHz
$1 \text{ MHz} \leq \Delta f \leq \min(\Delta f_{\text{max}}, 10 \text{ MHz})$	$1,5 \text{ MHz} \leq f_{\text{offset}} < \min(f_{\text{offset}_{\text{max}}}, 10,5 \text{ MHz})$	-11,2 dBm	1 MHz
$10 \text{ MHz} \leq \Delta f \leq \Delta f_{\text{max}}$	$10,5 \text{ MHz} \leq f_{\text{offset}} < f_{\text{offset}_{\text{max}}}$	-15 dBm (note 4)	1 MHz
<p>NOTE 1: For <i>TAB connectors</i> supporting <i>non-contiguous spectrum</i> operation within any <i>operating band</i> the <i>basic limit</i> within <i>sub-block gaps</i> is calculated as a cumulative sum of contributions from adjacent sub-blocks on each side of the <i>sub-block gap</i>, where the contribution from the far-end sub-block shall be scaled according to the measurement bandwidth of the near-end sub-block. Exception is $\Delta f \geq 10 \text{ MHz}$ from both adjacent sub-blocks on each side of the <i>sub-block gap</i>, where the <i>basic limit</i> within <i>sub-block gaps</i> shall be -15 dBm/MHz.</p> <p>NOTE 2: For <i>multi-band TAB connectors</i> with <i>Inter RF Bandwidth gap</i> $< 2 \times \Delta f_{\text{OBUE}}$ MHz the <i>basic limit</i> within the <i>Inter RF Bandwidth gaps</i> is calculated as a cumulative sum of contributions from adjacent <i>sub-blocks</i> on each side of the <i>Inter RF Bandwidth gap</i>, where the contribution from the far-end sub-block or <i>Base Station RF Bandwidth</i> shall be scaled according to the measurement bandwidth of the near-end sub-block or <i>Base Station RF Bandwidth</i>.</p> <p>NOTE 3: This frequency range ensures that the range of values of f_{offset} is continuous.</p> <p>NOTE 4: The requirement is not applicable when $\Delta f_{\text{max}} < 10 \text{ MHz}$.</p>			

Table 4.3.2.2.1.2-2a: Wide Area BS operating band unwanted emissions limits for BC1 and BC3 for bands $\leq 1 \text{ GHz}$, for BS supporting NR and not supporting UTRA

Frequency offset of measurement filter -3 dB point, Δf	Frequency offset of measurement filter centre frequency, f_{offset}	<i>Basic limit</i> (notes 1 and 2)	<i>Measurement bandwidth</i>
$0 \text{ MHz} \leq \Delta f < 5 \text{ MHz}$	$0,05 \text{ MHz} \leq f_{\text{offset}} < 5,05 \text{ MHz}$	$-5,5 - \frac{7}{5} \times (f_{\text{offset}} - 0,05) \text{ dBm}$	100 kHz
$5 \text{ MHz} \leq \Delta f < \min(10 \text{ MHz}, \Delta f_{\text{max}})$	$5,05 \text{ MHz} \leq f_{\text{offset}} < \min(10,05 \text{ MHz}, f_{\text{offset}_{\text{max}}})$	-12,5 dBm	
$10 \text{ MHz} \leq \Delta f \leq \Delta f_{\text{max}}$	$10,05 \text{ MHz} \leq f_{\text{offset}} < f_{\text{offset}_{\text{max}}}$	-16 dBm (note 3)	
<p>NOTE 1: For a <i>MSR TAB connector</i> supporting <i>non-contiguous spectrum</i> operation within any <i>operating band</i>, the emission limits within <i>sub-block gaps</i> is calculated as a cumulative sum of contributions from adjacent sub-blocks on each side of the <i>sub-block gap</i>. Exception is $\Delta f \geq 10 \text{ MHz}$ from both adjacent sub-blocks on each side of the <i>sub-block gap</i>, where the emission limits within <i>sub-block gaps</i> shall be -16 dBm/100 kHz.</p> <p>NOTE 2: For <i>multi-band TAB connectors</i> with <i>Inter RF Bandwidth gap</i> $< 2 \times \Delta f_{\text{OBUE}}$ the emission limits within the <i>Inter RF Bandwidth gaps</i> is calculated as a cumulative sum of contributions from adjacent <i>sub-blocks</i> or <i>Base Station RF Bandwidth</i> on each side of the <i>Inter RF Bandwidth gap</i>.</p> <p>NOTE 3: The requirement is not applicable when $\Delta f_{\text{max}} < 10 \text{ MHz}$.</p>			

Table 4.3.2.2.1.2-2b: Wide Area BS operating band unwanted emissions limits for BC1 and BC3 for bands above 1 GHz and ≤ 3 GHz, for BS supporting NR (except operation in Band 1 or 65) and not supporting UTRA

Frequency offset of measurement filter -3 dB point, Δf	Frequency offset of measurement filter centre frequency, f_{offset}	Basic limit (notes 1 and 2)	Measurement bandwidth
$0 \text{ MHz} \leq \Delta f < 5 \text{ MHz}$	$0,05 \text{ MHz} \leq f_{\text{offset}} < 5,05 \text{ MHz}$	$-5,5 - \frac{7}{5} \times (f_{\text{offset}} - 0,05) \text{ dBm}$	100 kHz
$5 \text{ MHz} \leq \Delta f < \min(10 \text{ MHz}, \Delta f_{\text{max}})$	$5,05 \text{ MHz} \leq f_{\text{offset}} < \min(10,05 \text{ MHz}, f_{\text{offset}_{\text{max}}})$	-12,5 dBm	100 kHz
$10 \text{ MHz} \leq \Delta f \leq \Delta f_{\text{max}}$	$10,5 \text{ MHz} \leq f_{\text{offset}} < f_{\text{offset}_{\text{max}}}$	-15 dBm (note 3)	1 MHz
NOTE 1: For a MSR <i>TAB connector</i> supporting <i>non-contiguous spectrum</i> operation within any <i>operating band</i> , the emission limits within <i>sub-block gaps</i> is calculated as a cumulative sum of contributions from adjacent sub-blocks on each side of the <i>sub-block gap</i> . Exception is $\Delta f \geq 10 \text{ MHz}$ from both adjacent sub-blocks on each side of the <i>sub-block gap</i> , where the emission limits within <i>sub-block gaps</i> shall be -15 dBm/MHz.			
NOTE 2: For <i>multi-band TAB connectors</i> with <i>Inter RF Bandwidth gap</i> $< 2 \times \Delta f_{\text{OBUE}}$ the emission limits within the <i>Inter RF Bandwidth gaps</i> is calculated as a cumulative sum of contributions from adjacent <i>sub-blocks</i> or <i>Base Station RF Bandwidth</i> on each side of the <i>Inter RF Bandwidth gap</i> .			
NOTE 3: The requirement is not applicable when $\Delta f_{\text{max}} < 10 \text{ MHz}$.			

Table 4.3.2.2.1.2-2c: Wide Area BS operating band unwanted emissions limits for BC1 and BC3 for bands above 3 GHz for BS supporting NR and not supporting UTRA

Frequency offset of measurement filter -3 dB point, Δf	Frequency offset of measurement filter centre frequency, f_{offset}	Basic limit (notes 1 and 2)	Measurement bandwidth
$0 \text{ MHz} \leq \Delta f < 5 \text{ MHz}$	$0,05 \text{ MHz} \leq f_{\text{offset}} < 5,05 \text{ MHz}$	$-5,2 - \frac{7}{5} \times (f_{\text{offset}} - 0,05) \text{ dBm}$	100 kHz
$5 \text{ MHz} \leq \Delta f < \min(10 \text{ MHz}, \Delta f_{\text{max}})$	$5,05 \text{ MHz} \leq f_{\text{offset}} < \min(10,05 \text{ MHz}, f_{\text{offset}_{\text{max}}})$	-12,2 dBm	100 kHz
$10 \text{ MHz} \leq \Delta f \leq \Delta f_{\text{max}}$	$10,5 \text{ MHz} \leq f_{\text{offset}} < f_{\text{offset}_{\text{max}}}$	-15 dBm (note 3)	1 MHz
NOTE 1: For a MSR <i>TAB connector</i> supporting <i>non-contiguous spectrum</i> operation within any <i>operating band</i> , the emission limits within <i>sub-block gaps</i> is calculated as a cumulative sum of contributions from adjacent <i>sub-blocks</i> on each side of the <i>sub-block gap</i> . Exception is $\Delta f \geq 10 \text{ MHz}$ from both adjacent <i>sub-blocks</i> on each side of the <i>sub-block gap</i> , where the emission limits within <i>sub-block gaps</i> shall be -15 dBm/MHz.			
NOTE 2: For <i>multi-band TAB connectors</i> with <i>Inter RF Bandwidth gap</i> $< 2 \times \Delta f_{\text{OBUE}}$ the emission limits within the <i>Inter RF Bandwidth gaps</i> is calculated as a cumulative sum of contributions from adjacent <i>sub-blocks</i> or <i>Base Station RF Bandwidth</i> on each side of the <i>Inter RF Bandwidth gap</i> .			
NOTE 3: The requirement is not applicable when $\Delta f_{\text{max}} < 10 \text{ MHz}$.			

Table 4.3.2.2.1.2-3: Medium Range BS operating band unwanted emissions limits for BC1 for bands ≤ 3 GHz, $31 < P_{\text{rated,c,cell}} - 10 \times \log_{10}(N_{\text{TXU,countedpercell}}) \leq 38$ dBm for BS not supporting NR

Frequency offset of measurement filter -3 dB point, Δf	Frequency offset of measurement filter centre frequency, f_{offset}	Basic limit (notes 1 and 2)	Measurement bandwidth
$0 \text{ MHz} \leq \Delta f < 0,6 \text{ MHz}$	$0,015 \text{ MHz} \leq f_{\text{offset}} < 0,615 \text{ MHz}$	$P_{\text{rated,c,cell}} - 10 \times \log_{10}(N_{\text{TXU,countedpercell}}) - 56,5 \text{ dB} - \frac{5}{3} \times (f_{\text{offset}} - 0,015) \text{ dBm}$	30 kHz
$0,6 \text{ MHz} \leq \Delta f < 1 \text{ MHz}$	$0,615 \text{ MHz} \leq f_{\text{offset}} < 1,015 \text{ MHz}$	$P_{\text{rated,c,cell}} - 10 \times \log_{10}(N_{\text{TXU,countedpercell}}) - 51,5 \text{ dB} - 15 \times (f_{\text{offset}} - 0,215) \text{ dBm}$	30 kHz
(note 3)	$1,015 \text{ MHz} \leq f_{\text{offset}} < 1,5 \text{ MHz}$	$P_{\text{rated,c,cell}} - 10 \times \log_{10}(N_{\text{TXU,countedpercell}}) - 63,5 \text{ dBm}$	30 kHz
$1 \text{ MHz} \leq \Delta f \leq 2,6 \text{ MHz}$	$1,5 \text{ MHz} \leq f_{\text{offset}} < 3,1 \text{ MHz}$	$P_{\text{rated,c,cell}} - 10 \times \log_{10}(N_{\text{TXU,countedpercell}}) - 50,5 \text{ dBm}$	1 MHz
$2,6 \text{ MHz} \leq \Delta f \leq 5 \text{ MHz}$	$3,1 \text{ MHz} \leq f_{\text{offset}} < 5,5 \text{ MHz}$	$\text{Min}(P_{\text{rated,c,cell}} - 10 \times \log_{10}(N_{\text{TXU,countedpercell}}) - 50,5 \text{ dB}, -13,5) \text{ dBm}$	1 MHz
$5 \text{ MHz} \leq \Delta f \leq \min(\Delta f_{\text{max}}, 10 \text{ MHz})$	$5,5 \text{ MHz} \leq f_{\text{offset}} < \min(f_{\text{offset}_{\text{max}}}, 10,5 \text{ MHz})$	$P_{\text{rated,c,cell}} - 10 \times \log_{10}(N_{\text{TXU,countedpercell}}) - 54,5 \text{ dBm}$	1 MHz
$10 \text{ MHz} \leq \Delta f \leq \Delta f_{\text{max}}$	$10,5 \text{ MHz} \leq f_{\text{offset}} < f_{\text{offset}_{\text{max}}}$	$P_{\text{rated,c,cell}} - 10 \times \log_{10}(N_{\text{TXU,countedpercell}}) - 56 \text{ dBm}$ (note 4)	1 MHz

NOTE 1: For TAB connectors supporting non-contiguous spectrum operation within any operating band the basic limit within sub-block gaps is calculated as a cumulative sum of contributions from adjacent sub-blocks on each side of the sub-block gap, where the contribution from the far-end sub-block shall be scaled according to the measurement bandwidth of the near-end sub-block. Exception is $\Delta f \geq 10$ MHz from both adjacent sub-blocks on each side of the sub-block gap, where the basic limit within sub-block gaps shall be $(P_{\text{rated,c,cell}} - 10 \times \log_{10}(N_{\text{TXU,countedpercell}}) - 56 \text{ dBm})/\text{MHz}$.

NOTE 2: For multi-band TAB connectors with Inter RF Bandwidth gap $< 2 \times \Delta f_{\text{OBUE}}$ MHz the basic limit within the Inter RF Bandwidth gaps is calculated as a cumulative sum of contributions from adjacent sub-blocks on each side of the Inter RF Bandwidth gap, where the contribution from the far-end sub-block or Base Station RF Bandwidth shall be scaled according to the measurement bandwidth of the near-end sub-block or Base Station RF Bandwidth.

NOTE 3: This frequency range ensures that the range of values of f_{offset} is continuous.

NOTE 4: The requirement is not applicable when $\Delta f_{\text{max}} < 10$ MHz.

Table 4.3.2.2.1.2-3a: Medium Range BS operating band unwanted emissions limits for BS supporting NR and not supporting UTRA in BC1 bands ≤ 3 GHz, BS maximum output power $31 < P_{\text{rated,c,cell}} - 10 \times \log_{10}(N_{\text{TXU,countedpercell}}) \leq 38$ dBm

Frequency offset of measurement filter -3 dB point, Δf	Frequency offset of measurement filter centre frequency, f_{offset}	Basic limit (notes 1 and 2)	Measurement bandwidth
$0 \text{ MHz} \leq \Delta f < 5 \text{ MHz}$	$0,05 \text{ MHz} \leq f_{\text{offset}} < 5,05 \text{ MHz}$	$P_{\text{rated,c,cell}} - 10 \times \log_{10}(N_{\text{TXU,countedpercell}}) - 51,5 \text{ dB} - \frac{7}{5} \times (f_{\text{offset}} - 0,05) \text{ dBm}$	100 kHz
$5 \text{ MHz} \leq \Delta f < \min(10 \text{ MHz}, \Delta f_{\text{max}})$	$5,05 \text{ MHz} \leq f_{\text{offset}} < \min(10,05 \text{ MHz}, f_{\text{offset}_{\text{max}}})$	$P_{\text{rated,c,cell}} - 10 \times \log_{10}(N_{\text{TXU,countedpercell}}) - 58,5 \text{ dBm}$	100 kHz
$10 \text{ MHz} \leq \Delta f \leq \Delta f_{\text{max}}$	$10,05 \text{ MHz} \leq f_{\text{offset}} < f_{\text{offset}_{\text{max}}}$	$\text{Min}(P_{\text{rated,c,cell}} - 10 \times \log_{10}(N_{\text{TXU,countedpercell}}) - 60, -25) \text{ dBm}$ (note 3)	100 kHz

NOTE 1: For a MSR TAB connector supporting non-contiguous spectrum operation within any operating band the emission limits within sub-block gaps is calculated as a cumulative sum of contributions from adjacent sub-blocks on each side of the sub-block gap. Exception is $\Delta f \geq 10$ MHz from both adjacent sub-blocks on each side of the sub-block gap, where the emission limits within sub-block gaps shall be $\text{Min}(P_{\text{rated,c,cell}} - 10 \times \log_{10}(N_{\text{TXU,countedpercell}}) - 60, -25) \text{ dBm}/100 \text{ kHz}$.

NOTE 2: For multi-band TAB connectors with Inter RF Bandwidth gap $< 2 \times \Delta f_{\text{OBUE}}$ the emission limits within the Inter RF Bandwidth gaps is calculated as a cumulative sum of contributions from adjacent sub-blocks or Base Station RF Bandwidth on each side of the Inter RF Bandwidth gap.

NOTE 3: The requirement is not applicable when $\Delta f_{\text{max}} < 10$ MHz.

Table 4.3.2.2.1.2-4: Medium Range BS operating band unwanted emissions limits for BC1 for bands > 3 GHz, $31 < P_{\text{rated,c,cell}} - 10 \times \log_{10}(N_{\text{TXU,countedpercell}}) \leq 38$ dBm for BS not supporting NR

Frequency offset of measurement filter -3 dB point, Δf	Frequency offset of measurement filter centre frequency, f_{offset}	basic limit (notes 1 and 2)	Measurement bandwidth
$0 \text{ MHz} \leq \Delta f < 0,6 \text{ MHz}$	$0,015 \text{ MHz} \leq f_{\text{offset}} < 0,615 \text{ MHz}$	$P_{\text{rated,c,cell}} - 10 \times \log_{10}(N_{\text{TXU,countedpercell}}) - 56,2 \text{ dB} - \frac{5}{3} \times (f_{\text{offset}} - 0,015) \text{ dBm}$	30 kHz
$0,6 \text{ MHz} \leq \Delta f < 1 \text{ MHz}$	$0,615 \text{ MHz} \leq f_{\text{offset}} < 1,015 \text{ MHz}$	$P_{\text{rated,c,cell}} - 10 \times \log_{10}(N_{\text{TXU,countedpercell}}) - 51,2 \text{ dB} - 15 \times (f_{\text{offset}} - 0,215) \text{ dBm}$	30 kHz
(note 3)	$1,015 \text{ MHz} \leq f_{\text{offset}} < 1,5 \text{ MHz}$	$P_{\text{rated,c,cell}} - 10 \times \log_{10}(N_{\text{TXU,countedpercell}}) - 63,2 \text{ dBm}$	30 kHz
$1 \text{ MHz} \leq \Delta f \leq 2,6 \text{ MHz}$	$1,5 \text{ MHz} \leq f_{\text{offset}} < 3,1 \text{ MHz}$	$P_{\text{rated,c,cell}} - 10 \times \log_{10}(N_{\text{TXU,countedpercell}}) - 50,2 \text{ dBm}$	1 MHz
$2,6 \text{ MHz} \leq \Delta f \leq 5 \text{ MHz}$	$3,1 \text{ MHz} \leq f_{\text{offset}} < 5,5 \text{ MHz}$	$\min(P_{\text{rated,c,cell}} - 10 \times \log_{10}(N_{\text{TXU,countedpercell}}) - 50,2, -13,2) \text{ dBm}$	1 MHz
$5 \text{ MHz} \leq \Delta f \leq \min(\Delta f_{\text{max}}, 10 \text{ MHz})$	$5,5 \text{ MHz} \leq f_{\text{offset}} < \min(f_{\text{offset}_{\text{max}}}, 10,5 \text{ MHz})$	$P_{\text{rated,c,cell}} - 10 \times \log_{10}(N_{\text{TXU,countedpercell}}) - 54,2 \text{ dBm}$	1 MHz
$10 \text{ MHz} \leq \Delta f \leq \Delta f_{\text{max}}$	$10,5 \text{ MHz} \leq f_{\text{offset}} < f_{\text{offset}_{\text{max}}}$	$P_{\text{rated,c,cell}} - 10 \times \log_{10}(N_{\text{TXU,countedpercell}}) - 56 \text{ dBm}$ (note 4)	1 MHz

NOTE 1: For TAB connectors supporting *non-contiguous spectrum* operation within any *operating band* the *basic limit* within *sub-block gaps* is calculated as a cumulative sum of contributions from adjacent sub-blocks on each side of the *sub-block gap*, where the contribution from the far-end sub-block shall be scaled according to the measurement bandwidth of the near-end sub-block. Exception is $\Delta f \geq 10$ MHz from both adjacent sub-blocks on each side of the *sub-block gap*, where the *basic limit* within *sub-block gaps* shall be $(P_{\text{rated,c,cell}} - 10 \times \log_{10}(N_{\text{TXU,countedpercell}}) - 56 \text{ dB})/\text{MHz}$.

NOTE 2: For *multi-band TAB connectors* with *Inter RF Bandwidth gap* $< 2 \times \Delta f_{\text{OBUE}}$ MHz the *basic limit* within the *Inter RF Bandwidth gaps* is calculated as a cumulative sum of contributions from adjacent *sub-blocks* on each side of the *Inter RF Bandwidth gap*, where the contribution from the far-end *sub-block* or *Base Station RF Bandwidth* shall be scaled according to the *measurement bandwidth* of the near-end *sub-block* or *Base Station RF Bandwidth*.

NOTE 3: This frequency range ensures that the range of values of f_{offset} is continuous.

NOTE 4: The requirement is not applicable when $\Delta f_{\text{max}} < 10$ MHz.

Table 4.3.2.2.1.2-4a: Medium Range BS operating band unwanted emissions limits for BS supporting NR and not supporting UTRA in BC1 bands > 3 GHz, BS maximum output power $31 < P_{\text{rated,c,cell}} - 10 \times \log_{10}(N_{\text{TXU,countedpercell}}) \leq 38$ dBm

Frequency offset of measurement filter -3 dB point, Δf	Frequency offset of measurement filter centre frequency, f_{offset}	Basic limit (notes 1 and 2)	Measurement bandwidth
$0 \text{ MHz} \leq \Delta f < 5 \text{ MHz}$	$0,05 \text{ MHz} \leq f_{\text{offset}} < 5,05 \text{ MHz}$	$P_{\text{rated,c,cell}} - 10 \times \log_{10}(N_{\text{TXU,countedpercell}}) - 51,2 \text{ dB} - \frac{7}{5} \times (f_{\text{offset}} - 0,05) \text{ dBm}$	100 kHz
$5 \text{ MHz} \leq \Delta f < \min(10 \text{ MHz}, \Delta f_{\text{max}})$	$5,05 \text{ MHz} \leq f_{\text{offset}} < \min(10,05 \text{ MHz}, f_{\text{offset}_{\text{max}}})$	$P_{\text{rated,c,cell}} - 10 \times \log_{10}(N_{\text{TXU,countedpercell}}) - 58,2 \text{ dBm}$	100 kHz
$10 \text{ MHz} \leq \Delta f \leq \Delta f_{\text{max}}$	$10,05 \text{ MHz} \leq f_{\text{offset}} < f_{\text{offset}_{\text{max}}}$	$\min(P_{\text{rated,c,cell}} - 60 \text{ dB}, -25 \text{ dBm})$ $\min(P_{\text{rated,c,cell}} - 10 \times \log_{10}(N_{\text{TXU,countedpercell}}) - 60 \text{ dB}, -25) \text{ dBm}$ (note 3)	100 kHz

NOTE 1: For a BS supporting *non-contiguous spectrum* operation within any *operating band* the emission limits within *sub-block gaps* is calculated as a cumulative sum of contributions from adjacent sub-blocks on each side of the *sub-block gap*. Exception is $\Delta f \geq 10$ MHz from both adjacent sub-blocks on each side of the *sub-block gap*, where the emission limits within *sub-block gaps* shall be $\min(P_{\text{rated,c,cell}} - 10 \times \log_{10}(N_{\text{TXU,countedpercell}}) - 60 \text{ dB}, -25 \text{ dBm}) / 100 \text{ kHz}$.

NOTE 2: For *multi-band TAB connectors* with *Inter RF Bandwidth gap* $< 2 \times \Delta f_{\text{OBUE}}$ the emission limits within the *Inter RF Bandwidth gaps* is calculated as a cumulative sum of contributions from adjacent *sub-blocks* or *RF Bandwidth* on each side of the *Inter RF Bandwidth gap*.

NOTE 3: The requirement is not applicable when $\Delta f_{\text{max}} < 10$ MHz.

Table 4.3.2.2.1.2-5: Medium Range BS operating band unwanted emissions limits for BC1 for bands ≤ 3 GHz, $P_{\text{rated,c,cell}} - 10 \times \log_{10}(N_{\text{TXU,countedpercell}}) \leq 31$ dBm for BS not supporting NR

Frequency offset of measurement filter -3 dB point, Δf	Frequency offset of measurement filter centre frequency, f_{offset}	basic limit (notes 1 and 2)	Measurement bandwidth
$0 \text{ MHz} \leq \Delta f < 0,6 \text{ MHz}$	$0,015 \text{ MHz} \leq f_{\text{offset}} < 0,615 \text{ MHz}$	$-25,5 - \frac{7}{5} \times (f_{\text{offset}} - 0,015) \text{ dBm}$	30 kHz
$0,6 \text{ MHz} \leq \Delta f < 1 \text{ MHz}$	$0,615 \text{ MHz} \leq f_{\text{offset}} < 1,015 \text{ MHz}$	$-20,5 - 15 \times (f_{\text{offset}} - 0,215) \text{ dBm}$	30 kHz
(note 3)	$1,015 \text{ MHz} \leq f_{\text{offset}} < 1,5 \text{ MHz}$	-32,5 dBm	30 kHz
$1 \text{ MHz} \leq \Delta f \leq 5 \text{ MHz}$	$1,5 \text{ MHz} \leq f_{\text{offset}} < 5,5 \text{ MHz}$	-19,5 dBm	1 MHz
$5 \text{ MHz} \leq \Delta f \leq \min(\Delta f_{\text{max}}, 10 \text{ MHz})$	$5,5 \text{ MHz} \leq f_{\text{offset}} < \min(f_{\text{offset}_{\text{max}}}, 10,5 \text{ MHz})$	-23,5 dBm	1 MHz
$10 \text{ MHz} \leq \Delta f \leq \Delta f_{\text{max}}$	$10,5 \text{ MHz} \leq f_{\text{offset}} < f_{\text{offset}_{\text{max}}}$	-25 dBm (note 4)	1 MHz

NOTE 1: For TAB connectors supporting *non-contiguous spectrum* operation within any *operating band* the *basic limit* within *sub-block gaps* is calculated as a cumulative sum of contributions from adjacent sub-blocks on each side of the *sub-block gap*, where the contribution from the far-end sub-block shall be scaled according to the measurement bandwidth of the near-end sub-block. Exception is $\Delta f \geq 10$ MHz from both adjacent sub-blocks on each side of the *sub-block gap*, where the *basic limit* within *sub-block gaps* shall be -25 dBm/MHz.

NOTE 2: For *multi-band TAB connectors* with *Inter RF Bandwidth gap* $< 2 \times \Delta f_{\text{OBU E}}$ MHz the *basic limit* within the *Inter RF Bandwidth gaps* is calculated as a cumulative sum of contributions from adjacent *sub-blocks* on each side of the *Inter RF Bandwidth gap*, where the contribution from the far-end *sub-block* or *Base Station RF Bandwidth* shall be scaled according to the *measurement bandwidth* of the near-end *sub-block* or *Base Station RF Bandwidth*.

NOTE 3: This frequency range ensures that the range of values of f_{offset} is continuous.

NOTE 4: The requirement is not applicable when $\Delta f_{\text{max}} < 10$ MHz.

Table 4.3.2.2.1.2-5a: Medium Range BS operating band unwanted emissions limits for BS supporting NR and not supporting UTRA in BC1 bands ≤ 3 GHz, BS maximum output power $P_{\text{rated,c,cell}} - 10 \times \log_{10}(N_{\text{TXU,countedpercell}}) \leq 31$ dBm

Frequency offset of measurement filter -3 dB point, Δf	Frequency offset of measurement filter centre frequency, f_{offset}	Basic limit (notes 1 and 2)	Measurement bandwidth
$0 \text{ MHz} \leq \Delta f < 5 \text{ MHz}$	$0,05 \text{ MHz} \leq f_{\text{offset}} < 5,05 \text{ MHz}$	$-20,5 - \frac{7}{5} \times (f_{\text{offset}} - 0,05) \text{ dBm}$	100 kHz
$5 \text{ MHz} \leq \Delta f < \min(10 \text{ MHz}, \Delta f_{\text{max}})$	$5,05 \text{ MHz} \leq f_{\text{offset}} < \min(10,05 \text{ MHz}, f_{\text{offset}_{\text{max}}})$	-27,5 dBm	100 kHz
$10 \text{ MHz} \leq \Delta f \leq \Delta f_{\text{max}}$	$10,05 \text{ MHz} \leq f_{\text{offset}} < f_{\text{offset}_{\text{max}}}$	-29 dBm (note 3)	100 kHz

NOTE 1: For a BS supporting *non-contiguous spectrum* operation within any *operating band* the emission limits within *sub-block gaps* is calculated as a cumulative sum of contributions from adjacent sub-blocks on each side of the *sub-block gap*. Exception is $\Delta f \geq 10$ MHz from both adjacent sub-blocks on each side of the *sub-block gap*, where the emission limits within *sub-block gaps* shall be -29 dBm/100 kHz.

NOTE 2: For *multi-band TAB connectors* with *Inter RF Bandwidth gap* $< 2 \times \Delta f_{\text{OBU E}}$ the emission limits within the *Inter RF Bandwidth gaps* is calculated as a cumulative sum of contributions from adjacent *sub-blocks* or *Base Station RF Bandwidth* on each side of the *Inter RF Bandwidth gap*.

NOTE 3: The requirement is not applicable when $\Delta f_{\text{max}} < 10$ MHz.

Table 4.3.2.2.1-6: Medium Range BS operating band unwanted emissions limits for BC1, for bands > 3 GHz, $P_{\text{rated,c,cell}} - 10 \times \log_{10}(N_{\text{TXU,countedpercell}}) \leq 31$ dBm for BS not supporting NR

Frequency offset of measurement filter -3 dB point, Δf	Frequency offset of measurement filter centre frequency, f_{offset}	basic limit (notes 1 and 2)	Measurement bandwidth
$0 \text{ MHz} \leq \Delta f < 0,6 \text{ MHz}$	$0,015 \text{ MHz} \leq f_{\text{offset}} < 0,615 \text{ MHz}$	$-25,2 - \frac{7}{5} \times (f_{\text{offset}} - 0,015) \text{ dBm}$	30 kHz
$0,6 \text{ MHz} \leq \Delta f < 1 \text{ MHz}$	$0,615 \text{ MHz} \leq f_{\text{offset}} < 1,015 \text{ MHz}$	$-20,2 - 15 \times (f_{\text{offset}} - 0,215) \text{ dBm}$	30 kHz
(note 3)	$1,015 \text{ MHz} \leq f_{\text{offset}} < 1,5 \text{ MHz}$	-32,2 dBm	30 kHz
$1 \text{ MHz} \leq \Delta f \leq 5 \text{ MHz}$	$1,5 \text{ MHz} \leq f_{\text{offset}} < 5,5 \text{ MHz}$	-19,2 dBm	1 MHz
$5 \text{ MHz} \leq \Delta f \leq \min(\Delta f_{\text{max}}, 10 \text{ MHz})$	$5,5 \text{ MHz} \leq f_{\text{offset}} < \min(f_{\text{offset,max}}, 10,5 \text{ MHz})$	-23,2 dBm	1 MHz
$10 \text{ MHz} \leq \Delta f \leq \Delta f_{\text{max}}$	$10,5 \text{ MHz} \leq f_{\text{offset}} < f_{\text{offset,max}}$	-25 dBm (note 4)	1 MHz

NOTE 1: For TAB connectors supporting *non-contiguous spectrum* operation within any *operating band* the *basic limit* within *sub-block gaps* is calculated as a cumulative sum of contributions from adjacent sub-blocks on each side of the *sub-block gap*, where the contribution from the far-end sub-block shall be scaled according to the measurement bandwidth of the near-end sub-block. Exception is $\Delta f \geq 10$ MHz from both adjacent sub-blocks on each side of the *sub-block gap*, where the *basic limit* within *sub-block gaps* shall be -25 dBm/MHz.

NOTE 2: For *multi-band TAB connectors* with *Inter RF Bandwidth gap* $< 2 \times \Delta f_{\text{OBUe}}$ MHz the *basic limit* within the *Inter RF Bandwidth gaps* is calculated as a cumulative sum of contributions from adjacent *sub-blocks* on each side of the *Inter RF Bandwidth gap*, where the contribution from the far-end *sub-block* or *Base Station RF Bandwidth* shall be scaled according to the *measurement bandwidth* of the near-end *sub-block* or *Base Station RF Bandwidth*.

NOTE 3: This frequency range ensures that the range of values of f_{offset} is continuous.

NOTE 4: The requirement is not applicable when $\Delta f_{\text{max}} < 10$ MHz.

Table 4.3.2.2.1-6a: Medium Range BS operating band unwanted emissions limits for BS supporting NR and not supporting UTRA in BC1 bands > 3 GHz, BS maximum output power $P_{\text{rated,c,cell}} - 10 \times \log_{10}(N_{\text{TXU,countedpercell}}) \leq 31$ dBm

Frequency offset of measurement filter -3 dB point, Δf	Frequency offset of measurement filter centre frequency, f_{offset}	Basic limit (notes 1 and 2)	Measurement bandwidth
$0 \text{ MHz} \leq \Delta f < 5 \text{ MHz}$	$0,05 \text{ MHz} \leq f_{\text{offset}} < 5,05 \text{ MHz}$	$-20,2 - \frac{7}{5} \times (f_{\text{offset}} - 0,05) \text{ dBm}$	100 kHz
$5 \text{ MHz} \leq \Delta f < \min(10 \text{ MHz}, \Delta f_{\text{max}})$	$5,05 \text{ MHz} \leq f_{\text{offset}} < \min(10,05 \text{ MHz}, f_{\text{offset,max}})$	-27,2 dBm	100 kHz
$10 \text{ MHz} \leq \Delta f \leq \Delta f_{\text{max}}$	$10,05 \text{ MHz} \leq f_{\text{offset}} < f_{\text{offset,max}}$	-29 dBm (note 3)	100 kHz

NOTE 1: For a BS supporting *non-contiguous spectrum* operation within any *operating band* the emission limits within *sub-block gaps* is calculated as a cumulative sum of contributions from adjacent sub-blocks on each side of the *sub-block gap*. Exception is $\Delta f \geq 10$ MHz from both adjacent sub-blocks on each side of the *sub-block gap*, where the emission limits within *sub-block gaps* shall be -29 dBm/100 kHz.

NOTE 2: For *multi-band TAB connectors* with *Inter RF Bandwidth gap* $< 2 \times \Delta f_{\text{OBUe}}$ the emission limits within the *Inter RF Bandwidth gaps* is calculated as a cumulative sum of contributions from adjacent *sub-blocks* or *Base Station RF Bandwidth* on each side of the *Inter RF Bandwidth gap*.

NOTE 3: The requirement is not applicable when $\Delta f_{\text{max}} < 10$ MHz.

Table 4.3.2.2.1.2-7: Local Area BS operating band unwanted emissions limits for BC1 for bands ≤ 3 GHz

Frequency offset of measurement filter -3 dB point, Δf	Frequency offset of measurement filter centre frequency, f_{offset}	basic limit (notes 1 and 2)	Measurement bandwidth
$0 \text{ MHz} \leq \Delta f < 5 \text{ MHz}$	$0,05 \text{ MHz} \leq f_{\text{offset}} < 5,05 \text{ MHz}$	$-28,5 - \frac{7}{5} \times (f_{\text{offset}} - 0,05) \text{ dBm}$	100 kHz
$5 \text{ MHz} \leq \Delta f < \min(10 \text{ MHz}, \Delta f_{\text{max}})$	$5,05 \text{ MHz} \leq f_{\text{offset}} < \min(10,05 \text{ MHz}, f_{\text{offset}_{\text{max}}})$	-35,5 dBm	100 kHz
$10 \text{ MHz} \leq \Delta f \leq \Delta f_{\text{max}}$	$10,05 \text{ MHz} \leq f_{\text{offset}} < f_{\text{offset}_{\text{max}}}$	-37 dBm (note 3)	100 kHz
NOTE 1: For TAB connectors supporting <i>non-contiguous spectrum</i> operation within any <i>operating band</i> the <i>basic limit</i> within <i>sub-block gaps</i> is calculated as a cumulative sum of contributions from adjacent sub-blocks on each side of the <i>sub-block gap</i> . Exception is $\Delta f \geq 10 \text{ MHz}$ from both adjacent sub-blocks on each side of the <i>sub-block gap</i> , where the <i>basic limit</i> within <i>sub-block gaps</i> shall be -37 dBm/100 kHz.			
NOTE 2: For <i>multi-band TAB connectors</i> with <i>Inter RF Bandwidth gap</i> $< 2 \times \Delta f_{\text{OBUE}}$ MHz the <i>basic limit</i> within the <i>Inter RF Bandwidth gaps</i> is calculated as a cumulative sum of contributions from adjacent <i>sub-blocks</i> on each side of the <i>Inter RF Bandwidth gap</i> .			
NOTE 3: The requirement is not applicable when $\Delta f_{\text{max}} < 10 \text{ MHz}$.			

Table 4.3.2.2.1.2-8: Local Area BS operating band unwanted emissions limits for BC1 for bands > 3 GHz

Frequency offset of measurement filter -3 dB point, Δf	Frequency offset of measurement filter centre frequency, f_{offset}	basic limit (notes 1 and 2)	Measurement bandwidth
$0 \text{ MHz} \leq \Delta f < 5 \text{ MHz}$	$0,05 \text{ MHz} \leq f_{\text{offset}} < 5,05 \text{ MHz}$	$-28,2 - \frac{7}{5} \times (f_{\text{offset}} - 0,05) \text{ dBm}$	100 kHz
$5 \text{ MHz} \leq \Delta f < \min(10 \text{ MHz}, \Delta f_{\text{max}})$	$5,05 \text{ MHz} \leq f_{\text{offset}} < \min(10,05 \text{ MHz}, f_{\text{offset}_{\text{max}}})$	-35,2 dBm	100 kHz
$10 \text{ MHz} \leq \Delta f \leq \Delta f_{\text{max}}$	$10,05 \text{ MHz} \leq f_{\text{offset}} < f_{\text{offset}_{\text{max}}}$	-37 dBm (note 3)	100 kHz
NOTE 1: For TAB connectors supporting <i>non-contiguous spectrum</i> operation within any <i>operating band</i> the <i>basic limit</i> within <i>sub-block gaps</i> is calculated as a cumulative sum of contributions from adjacent sub-blocks on each side of the <i>sub-block gap</i> . Exception is $\Delta f \geq 10 \text{ MHz}$ from both adjacent sub-blocks on each side of the <i>sub-block gap</i> , where the <i>basic limit</i> within <i>sub-block gaps</i> shall be -37 dBm/100 kHz.			
NOTE 2: For <i>multi-band TAB connectors</i> with <i>Inter RF Bandwidth gap</i> $< 2 \times \Delta f_{\text{OBUE}}$ MHz the <i>basic limit</i> within the <i>Inter RF Bandwidth gaps</i> is calculated as a cumulative sum of contributions from adjacent <i>sub-blocks</i> on each side of the <i>Inter RF Bandwidth gap</i> .			
NOTE 3: The requirement is not applicable when $\Delta f_{\text{max}} < 10 \text{ MHz}$.			

4.3.2.2.1.3 Basic limit for Band Category 2

For TAB connectors operating in Band Category 2 the requirement applies outside the *Base Station RF Bandwidth edges*. In addition, for TAB connectors operating in *non-contiguous spectrum*, it applies inside any *sub-block gap*.

Outside the *Base Station RF Bandwidth edges*, *basic limits* are specified in tables below, where:

- Δf is the separation between the *Base Station RF Bandwidth edge* frequency and the nominal -3 dB point of the measuring filter closest to the carrier frequency.
- f_{offset} is the separation between the *Base Station RF Bandwidth edge* frequency and the centre of the measuring filter.
- $f_{\text{offset}_{\text{max}}}$ is the offset to the frequency Δf_{OBUE} outside the *downlink operating band*.
- Δf_{max} is equal to $f_{\text{offset}_{\text{max}}}$ minus half of the bandwidth of the measuring filter.

For *multi-band TAB connectors*, inside any *Inter RF Bandwidth gaps* with $W_{\text{gap}} < 2 \times \Delta f_{\text{OBUE}}$ MHz, a combined *basic limit* shall be applied which is the cumulative sum of the *basic limits* specified at the *Base Station RF Bandwidth edges* on each side of the *Inter RF Bandwidth gap*. The *basic limit* for *Base Station RF Bandwidth edge* is specified in tables below, where in this case:

- Δf is the separation between the *Base Station RF Bandwidth edge* frequency and the nominal -3 dB point of the measuring filter closest to the carrier frequency.
- f_{offset} is the separation between the *Base Station RF Bandwidth edge* frequency and the centre of the measuring filter.
- $f_{\text{offset}_{\text{max}}}$ is equal to the *Inter RF Bandwidth gap* minus half of the bandwidth of the measuring filter.
- Δf_{max} is equal to $f_{\text{offset}_{\text{max}}}$ minus half of the bandwidth of the measuring filter.

For *multi-band TAB connectors* and where there is no carrier transmitted in an *operating band*, no cumulative *basic limits* are applied in the *inter-band gap* between a supported downlink band with carrier(s) transmitted and a supported downlink band without any carrier transmitted; and:

- In case the *inter-band gap* between a supported downlink band with carrier(s) transmitted and a supported downlink band without any carrier transmitted less than is $2 \times \Delta f_{\text{OBUE}}$ MHz, $f_{\text{offset}_{\text{max}}}$ shall be the offset to the frequency Δf_{OBUE} outside the outermost edges of the two supported *downlink operating bands* and the *operating band unwanted emission limit* of the band where there are carriers transmitted, as defined in the tables of the present clause, shall apply across both supported downlink bands.
- In other cases, the *operating band unwanted emission basic limit* of the band where there are carriers transmitted, as defined in the tables of the present clause for the largest frequency offset (Δf_{max}), shall apply from Δf_{OBUE} below the lowest frequency, up to Δf_{OBUE} above the highest frequency of the supported *downlink operating band* without any carrier transmitted.

For a multicarrier *single-band connector* or a *single-band connector* configured for intra-band contiguous or non-contiguous carrier aggregation, the definitions above apply to the lower edge of the carrier transmitted at the lowest carrier frequency and the upper edge of the carrier transmitted at the highest carrier frequency within a specified frequency band.

Inside any *sub-block gap* for *TAB connectors* operating in *non-contiguous spectrum*, a combined *basic limit* shall be applied which is the cumulative sum of the *basic limit* specified for the adjacent sub-blocks on each side of the *sub-block gap*. The *basic limit* for each sub-block is specified in tables below, where in this case:

- Δf is the separation between the sub-block edge frequency and the nominal -3 dB point of the measuring filter closest to the sub-block edge.
- f_{offset} is the separation between the sub-block edge frequency and the centre of the measuring filter.
- $f_{\text{offset}_{\text{max}}}$ is equal to the *sub-block gap* bandwidth minus half of the bandwidth of the measuring filter.
- Δf_{max} is equal to $f_{\text{offset}_{\text{max}}}$ minus half of the bandwidth of the measuring filter.

Table 4.3.2.2.1.3-1: Wide Area BS operating band unwanted emissions limits for BC2, except those covered by tables 4.3.2.2.1.3-1a and 4.3.2.2.1.3-1b

Frequency offset of measurement filter -3 dB point, Δf	Frequency offset of measurement filter centre frequency, f_{offset}	<i>basic limit</i> (notes 2 and 3)	<i>Measurement bandwidth</i>
$0 \text{ MHz} \leq \Delta f < 0,2 \text{ MHz}$ (note 1)	$0,015 \text{ MHz} \leq f_{\text{offset}} < 0,215 \text{ MHz}$	-12,5 dBm	30 kHz
$0,2 \text{ MHz} \leq \Delta f < 1 \text{ MHz}$ (note 4)	$0,215 \text{ MHz} \leq f_{\text{offset}} < 1,015 \text{ MHz}$	$-12,5 - 15 \times (f_{\text{offset}} - 0,215) \text{ dBm}$	30 kHz
$1 \text{ MHz} \leq \Delta f \leq \min(\Delta f_{\text{max}}, 10 \text{ MHz})$	$1,015 \text{ MHz} \leq f_{\text{offset}} < 1,5 \text{ MHz}$	-24,5 dBm	30 kHz
$10 \text{ MHz} \leq \Delta f \leq \Delta f_{\text{max}}$	$1,5 \text{ MHz} \leq f_{\text{offset}} < \min(f_{\text{offset}_{\text{max}}}, 10,5 \text{ MHz})$	-11,5 dBm	1 MHz
	$10,5 \text{ MHz} \leq f_{\text{offset}} < f_{\text{offset}_{\text{max}}}$	-15 dBm (note 5)	1 MHz
NOTE 1: For operation with an E-UTRA 1,4 or 3 MHz carrier adjacent to the <i>Base Station RF Bandwidth edge</i> or the <i>sub-block edge</i> , the limits in table 4.3.2.2.1.3-2 apply for $0 \text{ MHz} \leq \Delta f < 0,15 \text{ MHz}$.			
NOTE 2: For <i>TAB connectors</i> supporting <i>non-contiguous spectrum</i> operation within any <i>operating band</i> the <i>basic limit</i> within <i>sub-block gaps</i> is calculated as a cumulative sum of contributions from adjacent sub-blocks on each side of the <i>sub-block gap</i> , where the contribution from the far-end sub-block shall be scaled according to the measurement bandwidth of the near-end sub-block. Exception is $\Delta f \geq 10 \text{ MHz}$ from both adjacent sub-blocks on each side of the <i>sub-block gap</i> , where the <i>basic limit</i> within <i>sub-block gaps</i> shall be -15 dBm/MHz.			
NOTE 3: For <i>multi-band TAB connectors</i> with <i>Inter RF Bandwidth gap</i> $< 2 \times \Delta f_{\text{OBUE}}$ MHz operation the <i>basic limit</i> within the <i>Inter RF Bandwidth gaps</i> is calculated as a cumulative sum of contributions from adjacent <i>sub-blocks</i> on each side of the <i>Inter RF Bandwidth gap</i> , where the contribution from the far-end <i>sub-block</i> or <i>Base Station RF Bandwidth</i> shall be scaled according to the <i>measurement bandwidth</i> of the near-end <i>sub-block</i> or <i>Base Station RF Bandwidth</i> .			
NOTE 4: This frequency range ensures that the range of values of f_{offset} is continuous.			
NOTE 5: The requirement is not applicable when $\Delta f_{\text{max}} < 10 \text{ MHz}$.			

Table 4.3.2.2.1.3-1a: Wide Area BS operating band unwanted emissions limits for BC2 for bands $\leq 1 \text{ GHz}$, for BS supporting NR (except for BS operating in band 8) and not supporting UTRA

Frequency offset of measurement filter -3 dB point, Δf	Frequency offset of measurement filter centre frequency, f_{offset}	<i>Basic limit</i> (notes 1 and 2)	<i>Measurement bandwidth</i>
$0 \text{ MHz} \leq \Delta f < 5 \text{ MHz}$	$0,05 \text{ MHz} \leq f_{\text{offset}} < 5,05 \text{ MHz}$	$-5,5 - \frac{7}{5} \times (f_{\text{offset}} - 0,05) \text{ dBm}$	100 kHz
$5 \text{ MHz} \leq \Delta f < \min(10 \text{ MHz}, \Delta f_{\text{max}})$	$5,05 \text{ MHz} \leq f_{\text{offset}} < \min(10,05 \text{ MHz}, f_{\text{offset}_{\text{max}}})$	-12,5 dBm	100 kHz
$10 \text{ MHz} \leq \Delta f \leq \Delta f_{\text{max}}$	$10,05 \text{ MHz} \leq f_{\text{offset}} < f_{\text{offset}_{\text{max}}}$	-16 dBm (note 4)	100 kHz
NOTE 1: For <i>TAB connectors</i> supporting <i>non-contiguous spectrum</i> operation within any <i>operating band</i> , the <i>basic limit</i> within <i>sub-block gaps</i> is calculated as a cumulative sum of contributions from adjacent sub-blocks on each side of the <i>sub-block gap</i> ,. Exception is $\Delta f \geq 10 \text{ MHz}$ from both adjacent sub-blocks on each side of the <i>sub-block gap</i> , where the <i>basic limit</i> within <i>sub-block gaps</i> shall be -16 dBm/100 kHz.			
NOTE 2: For <i>multi-band TAB connectors</i> with <i>Inter RF Bandwidth gap</i> $< 2 \times \Delta f_{\text{OBUE}}$ the <i>basic limit</i> within the <i>Inter RF Bandwidth gaps</i> is calculated as a cumulative sum of contributions from adjacent <i>sub-blocks</i> or <i>Base Station RF Bandwidth</i> on each side of the <i>Inter RF Bandwidth gap</i> .			
NOTE 3: For operation with an E-UTRA 1,4 or 3 MHz carrier adjacent to the <i>Base Station RF Bandwidth edge</i> or the <i>sub-block edge</i> , the limits in table 4.3.2.2.1.3-2 apply for $0 \text{ MHz} \leq \Delta f < 0,15 \text{ MHz}$.			
NOTE 4: The requirement is not applicable when $\Delta f_{\text{max}} < 10 \text{ MHz}$.			

Table 4.3.2.2.1.3-1b: Wide Area BS operating band unwanted emissions limits for BC2 for bands > 1 GHz, for BS supporting NR (except for BS operating in band 3) and not supporting UTRA

Frequency offset of measurement filter -3 dB point, Δf	Frequency offset of measurement filter centre frequency, f_{offset}	Basic limit (notes 1 and 2)	Measurement bandwidth
$0 \text{ MHz} \leq \Delta f < 5 \text{ MHz}$	$0,05 \text{ MHz} \leq f_{\text{offset}} < 5,05 \text{ MHz}$	$-5,5 - \frac{7}{5} \times (f_{\text{offset}} - 0,05) \text{ dBm}$	100 kHz
$5 \text{ MHz} \leq \Delta f < \min(10 \text{ MHz}, \Delta f_{\text{max}})$	$5,05 \text{ MHz} \leq f_{\text{offset}} < \min(10,05 \text{ MHz}, f_{\text{offset}_{\text{max}}})$	-12,5 dBm	100 kHz
$10 \text{ MHz} \leq \Delta f \leq \Delta f_{\text{max}}$	$10,5 \text{ MHz} \leq f_{\text{offset}} < f_{\text{offset}_{\text{max}}}$	-15 dBm (note 4)	1 MHz
NOTE 1: For TAB connectors supporting <i>non-contiguous spectrum</i> operation within any <i>operating band</i> , the <i>basic limit</i> within <i>sub-block gaps</i> is calculated as a cumulative sum of contributions from adjacent sub-blocks on each side of the <i>sub-block gap</i> . Exception is $\Delta f \geq 10 \text{ MHz}$ from both adjacent sub-blocks on each side of the <i>sub-block gap</i> , where the <i>basic limit</i> within <i>sub-block gaps</i> shall be -15 dBm/1 MHz.			
NOTE 2: For <i>multi-band TAB connectors</i> with <i>Inter RF Bandwidth gap</i> $< 2 \times \Delta f_{\text{OBU}}$ the <i>basic limit</i> within the <i>Inter RF Bandwidth gaps</i> is calculated as a cumulative sum of contributions from adjacent <i>sub-blocks</i> or <i>Base Station RF Bandwidth</i> on each side of the <i>Inter RF Bandwidth gap</i> .			
NOTE 3: For operation with an E-UTRA 1,4 or 3 MHz carrier adjacent to the <i>Base Station RF Bandwidth edge</i> or the <i>sub-block edge</i> , the limits in table 4.3.2.2.1.3-2 apply for $0 \text{ MHz} \leq \Delta f < 0,15 \text{ MHz}$.			
NOTE 4: The requirement is not applicable when $\Delta f_{\text{max}} < 10 \text{ MHz}$.			

Table 4.3.2.2.1.3-2: Wide Area BS operating band unwanted emissions limits for operation in BC2 with E-UTRA 1,4 or 3 MHz carriers adjacent to the Base Station RF Bandwidth edge or the sub-block edge

Frequency offset of measurement filter -3 dB point, Δf	Frequency offset of measurement filter centre frequency, f_{offset}	basic limit (notes 2 and 3)	Measurement bandwidth
$0 \text{ MHz} \leq \Delta f < 0,05 \text{ MHz}$	$0,015 \text{ MHz} \leq f_{\text{offset}} < 0,065 \text{ MHz}$	$\text{Max}(6,5 - 60 \times (f_{\text{offset}} - 0,015), -12,5) \text{ dBm}$	30 kHz
$0,05 \text{ MHz} \leq \Delta f < 0,15 \text{ MHz}$	$0,065 \text{ MHz} \leq f_{\text{offset}} < 0,165 \text{ MHz}$	$\text{Max}(3,5 - 160 \times (f_{\text{offset}} - 0,065), -12,5) \text{ dBm}$	30 kHz
NOTE 1: The limits in this table only apply for operation with an E-UTRA 1,4 or 3 MHz carrier adjacent to the <i>Base Station RF Bandwidth edge</i> or the <i>sub-block edge</i> .			
NOTE 2: For TAB connectors supporting <i>non-contiguous spectrum</i> operation within any <i>operating band</i> the <i>basic limit</i> within <i>sub-block gaps</i> is calculated as a cumulative sum of contributions from adjacent sub-blocks on each side of the <i>sub-block gap</i> .			
NOTE 3: For <i>multi-band TAB connectors</i> with <i>Inter RF Bandwidth gap</i> $< 2 \times \Delta f_{\text{OBU}}$ MHz the <i>basic limit</i> within the <i>Inter RF Bandwidth gaps</i> is calculated as a cumulative sum of contributions from adjacent <i>sub-blocks</i> on each side of the <i>Inter RF Bandwidth gap</i> .			

Table 4.3.2.2.1.3-3: Medium Range BS operating band unwanted emissions limits for BC2, $31 < P_{\text{rated,c,cell}} - 10 \times \log_{10}(N_{\text{TXU,countedpercell}}) \leq 38$ dBm for a BS not supporting NR

Frequency offset of measurement filter -3 dB point, Δf	Frequency offset of measurement filter centre frequency, f_{offset}	basic limit (notes 2 and 3)	Measurement bandwidth
$0 \text{ MHz} \leq \Delta f < 0,6 \text{ MHz}$ (note 1)	$0,015 \text{ MHz} \leq f_{\text{offset}} < 0,615 \text{ MHz}$	$P_{\text{rated,c,cell}} - 10 \times \log_{10}(N_{\text{TXU,countedpercell}}) - 56,5 \text{ dB} - \frac{5}{3} \times (f_{\text{offset}} - 0,015) \text{ dBm}$	30 kHz
$0,6 \text{ MHz} \leq \Delta f < 1 \text{ MHz}$ (note 4)	$0,615 \text{ MHz} \leq f_{\text{offset}} < 1,015 \text{ MHz}$	$P_{\text{rated,c,cell}} - 10 \times \log_{10}(N_{\text{TXU,countedpercell}}) - 51,5 \text{ dB} - 15 \times (f_{\text{offset}} - 0,215) \text{ dBm}$	30 kHz
	$1,015 \text{ MHz} \leq f_{\text{offset}} < 1,5 \text{ MHz}$	$P_{\text{rated,c,cell}} - 10 \times \log_{10}(N_{\text{TXU,countedpercell}}) - 63,5 \text{ dBm}$	30 kHz
$1 \text{ MHz} \leq \Delta f \leq 2,8 \text{ MHz}$	$1,5 \text{ MHz} \leq f_{\text{offset}} < 3,3 \text{ MHz}$	$P_{\text{rated,c,cell}} - 10 \times \log_{10}(N_{\text{TXU,countedpercell}}) - 50,5 \text{ dB}$	1 MHz
$2,8 \text{ MHz} \leq \Delta f \leq 5 \text{ MHz}$	$3,3 \text{ MHz} \leq f_{\text{offset}} < 5,5 \text{ MHz}$	$\text{Min}(P_{\text{rated,c,cell}} - 10 \times \log_{10}(N_{\text{TXU,countedpercell}}) - 50,5 \text{ dB}, -13,5) \text{ dBm}$	1 MHz
$5 \text{ MHz} \leq \Delta f \leq \min(\Delta f_{\text{max}}, 10 \text{ MHz})$	$5,5 \text{ MHz} \leq f_{\text{offset}} < \min(f_{\text{offset}_{\text{max}}}, 10,5 \text{ MHz})$	$P_{\text{rated,c,cell}} - 10 \times \log_{10}(N_{\text{TXU,countedpercell}}) - 54,5 \text{ dBm}$	1 MHz
$10 \text{ MHz} \leq \Delta f \leq \Delta f_{\text{max}}$	$10,5 \text{ MHz} \leq f_{\text{offset}} < f_{\text{offset}_{\text{max}}}$	$P_{\text{rated,c,cell}} - 10 \times \log_{10}(N_{\text{TXU,countedpercell}}) - 56 \text{ dBm}$ (note 5)	1 MHz

NOTE 1: For operation with an E-UTRA 1,4 or 3 MHz carrier adjacent to the *Base Station RF Bandwidth edge* or the sub-block edge, the limits in table 4.3.2.2.1.3-5 apply for $0 \text{ MHz} \leq \Delta f < 0,15 \text{ MHz}$.

NOTE 2: For *TAB connectors* supporting *non-contiguous spectrum* operation within any *operating band* the *basic limit* within *sub-block gaps* is calculated as a cumulative sum of contributions from adjacent sub-blocks on each side of the *sub-block gap*, where the contribution from the far-end sub-block shall be scaled according to the measurement bandwidth of the near-end sub-block. Exception is $\Delta f \geq 10 \text{ MHz}$ from both adjacent sub-blocks on each side of the *sub-block gap*, where the *basic limit* within *sub-block gaps* shall be $(P_{\text{rated,c,cell}} - 10 \times \log_{10}(N_{\text{TXU,countedpercell}}) - 56 \text{ dBm})/\text{MHz}$.

NOTE 3: For *multi-band TAB connectors* with *Inter RF Bandwidth gap* $< 2 \times \Delta f_{\text{OBUE}}$ MHz the *basic limit* within the *Inter RF Bandwidth gaps* is calculated as a cumulative sum of contributions from adjacent *sub-blocks* on each side of the *Inter RF Bandwidth gap*, where the contribution from the far-end *sub-block* or *Base Station RF Bandwidth* shall be scaled according to the *measurement bandwidth* of the near-end *sub-block* or *Base Station RF Bandwidth*.

NOTE 4: This frequency range ensures that the range of values of f_{offset} is continuous.

NOTE 5: The requirement is not applicable when $\Delta f_{\text{max}} < 10 \text{ MHz}$.

Table 4.3.2.2.1.3-3a: Medium Range BS operating band unwanted emissions limits for BS supporting NR and not supporting UTRA in BC2 bands, BS maximum output power $31 < P_{\text{rated,c,cell}} - 10 \times \log_{10}(N_{\text{TXU,countedpercell}}) \leq 38$ dBm

Frequency offset of measurement filter -3 dB point, Δf	Frequency offset of measurement filter centre frequency, f_{offset}	Basic limit (notes 1 and 2)	Measurement bandwidth
$0 \text{ MHz} \leq \Delta f < 5 \text{ MHz}$	$0,05 \text{ MHz} \leq f_{\text{offset}} < 5,05 \text{ MHz}$	$P_{\text{rated,c,cell}} - 10 \times \log_{10}(N_{\text{TXU,countedpercell}}) - 51,5 \text{ dB} - (7/5) \times (f_{\text{offset}}/\text{MHz} - 0,05) \text{ dB}$	100 kHz
$5 \text{ MHz} \leq \Delta f < \min(10 \text{ MHz}, \Delta f_{\text{max}})$	$5,05 \text{ MHz} \leq f_{\text{offset}} < \min(10,05 \text{ MHz}, f_{\text{offset}_{\text{max}}})$	$P_{\text{rated,c,cell}} - 10 \times \log_{10}(N_{\text{TXU,countedpercell}}) - 61,5 \text{ dB}$	100 kHz
$10 \text{ MHz} \leq \Delta f \leq \Delta f_{\text{max}}$	$10,05 \text{ MHz} \leq f_{\text{offset}} < f_{\text{offset}_{\text{max}}}$	$\text{Min}(P_{\text{rated,c,cell}} - 10 \times \log_{10}(N_{\text{TXU,countedpercell}}) - 60 \text{ dB}, -25 \text{ dBm})$ (note 4)	100 kHz

NOTE 1: For *TAB connectors* supporting *non-contiguous spectrum* operation within any *operating band* the *basic limit* within *sub-block gaps* is calculated as a cumulative sum of contributions from adjacent sub-blocks on each side of the *sub-block gap*. Exception is $\Delta f \geq 10 \text{ MHz}$ from both adjacent sub-blocks on each side of the *sub-block gap*, where the *basic limit* within *sub-block gaps* shall be $\text{Min}(P_{\text{rated,c,cell}} - 10 \times \log_{10}(N_{\text{TXU,countedpercell}}) - 60 \text{ dB}, -25 \text{ dBm}) / 100 \text{ kHz}$.

NOTE 2: For *multi-band TAB connectors* with *Inter RF Bandwidth gap* $< 2 \times \Delta f_{\text{OBUE}}$ the *basic limit* within the *Inter RF Bandwidth gaps* is calculated as a cumulative sum of contributions from adjacent *sub-blocks* or *Base Station RF Bandwidth* on each side of the *Inter RF Bandwidth gap*.

NOTE 3: For operation with an E-UTRA 1,4 or 3 MHz carrier adjacent to the *Base Station RF Bandwidth edge* or the sub-block edge, the limits in table 4.3.2.2.1.3-5 apply for $0 \text{ MHz} \leq \Delta f < 0,15 \text{ MHz}$.

NOTE 4: The requirement is not applicable when $\Delta f_{\text{max}} < 10 \text{ MHz}$.

Table 4.3.2.2.1.3-4: Medium Range BS operating band unwanted emissions limits for BC2, $P_{\text{rated,c,cell}} = 10 \times \log_{10}(N_{\text{TXU,countedpercell}}) \leq 31$ dBm for a BS not supporting NR

Frequency offset of measurement filter -3dB point, Δf	Frequency offset of measurement filter centre frequency, f_{offset}	<i>basic limit</i> (Notes 2 and 3)	Measurement bandwidth
0 MHz $\leq \Delta f < 0,6$ MHz (Note 1)	0,015 MHz $\leq f_{\text{offset}} < 0,615$ MHz	$-25,5 \text{ dBm} - \frac{5}{3} \left(\frac{f_{\text{offset}}}{\text{MHz}} - 0,015 \right) \text{ dB}$	30 kHz
0,6 MHz $\leq \Delta f < 1$ MHz	0,615 MHz $\leq f_{\text{offset}} < 1,015$ MHz	$-20,5 \text{ dBm} - 15 \cdot \left(\frac{f_{\text{offset}}}{\text{MHz}} - 0,215 \right) \text{ dB}$	30 kHz
(Note 4)	1,015 MHz $\leq f_{\text{offset}} < 1,5$ MHz	-32,5 dBm	30 kHz
1 MHz $\leq \Delta f \leq 5$ MHz	1,5 MHz $\leq f_{\text{offset}} < 5,5$ MHz	-19,5 dBm	1 MHz
5 MHz $\leq \Delta f \leq \min(\Delta f_{\text{max}}, 10 \text{ MHz})$	5,5 MHz $\leq f_{\text{offset}} < \min(f_{\text{offset}_{\text{max}}}, 10,5 \text{ MHz})$	-23,5 dBm	1 MHz
10 MHz $\leq \Delta f \leq \Delta f_{\text{max}}$	10,5 MHz $\leq f_{\text{offset}} < f_{\text{offset}_{\text{max}}}$	-25 dBm (Note 5)	1 MHz

NOTE 1: For operation with an E-UTRA 1,4 or 3 MHz carrier adjacent to the *Base Station RF Bandwidth edge* or the sub-block edge, the limits in table 4.3.2.2.1.3-6 apply for 0 MHz $\leq \Delta f < 0,15$ MHz.

NOTE 2: For *TAB connectors* supporting *non-contiguous spectrum operation* within any operating band the *basic limit* within *sub-block gaps* is calculated as a cumulative sum of contributions from adjacent sub-blocks on each side of the *sub-block gap*, where the contribution from the far-end sub-block shall be scaled according to the measurement bandwidth of the near-end sub-block. Exception is $\Delta f \geq 10$ MHz from both adjacent sub-blocks on each side of the *sub-block gap*, where the *basic limit* within *sub-block gaps* shall be -25 dBm/MHz.

NOTE 3: For *multi-band TAB connectors* with *Inter RF Bandwidth gap* $< 2 \times \Delta f_{\text{OBUe}}$ MHz the *basic limit* within the *Inter RF Bandwidth gaps* is calculated as a cumulative sum of contributions from adjacent sub-blocks on each side of the *Inter RF Bandwidth gap*, where the contribution from the far-end sub-block or *Base Station RF Bandwidth* shall be scaled according to the measurement bandwidth of the near-end sub-block or *Base Station RF Bandwidth*.

NOTE 4: This frequency range ensures that the range of values of f_{offset} is continuous.

NOTE 5: The requirement is not applicable when $\Delta f_{\text{max}} < 10$ MHz.

Table 4.3.2.2.1.3-4a: Medium Range BS operating band unwanted emissions limits for BS supporting NR but not supporting UTRA in BC2 bands, BS maximum output power $P_{\text{rated,c,cell}} = 10 \times \log_{10}(N_{\text{TXU,countedpercell}}) \leq 31$ dBm

Frequency offset of measurement filter -3 dB point, Δf	Frequency offset of measurement filter centre frequency, f_{offset}	<i>Basic limit</i> (notes 1 and 2)	<i>Measurement bandwidth</i>
0 MHz $\leq \Delta f < 5$ MHz	0,05 MHz $\leq f_{\text{offset}} < 5,05$ MHz	$-20,5 - \frac{7}{5} \times (f_{\text{offset}} - 0,05) \text{ dBm}$	100 kHz
5 MHz $\leq \Delta f < \min(10 \text{ MHz}, \Delta f_{\text{max}})$	5,05 MHz $\leq f_{\text{offset}} < \min(10,05 \text{ MHz}, f_{\text{offset}_{\text{max}}})$	-27,5 dBm	100 kHz
10 MHz $\leq \Delta f \leq \Delta f_{\text{max}}$	10,05 MHz $\leq f_{\text{offset}} < f_{\text{offset}_{\text{max}}}$	-29 dBm (note 4)	100 kHz

NOTE 1: For *TAB connectors* supporting *non-contiguous spectrum operation* within any operating band the *basic limit* within *sub-block gaps* is calculated as a cumulative sum of contributions from adjacent sub-blocks on each side of the *sub-block gap*. Exception is $\Delta f \geq 10$ MHz from both adjacent sub-blocks on each side of the *sub-block gap*, where the *basic limit* within *sub-block gaps* shall be -29 dBm/100 kHz.

NOTE 2: For *multi-band TAB connectors* with *Inter RF Bandwidth gap* $< 2 \times \Delta f_{\text{OBUe}}$ the *basic limit* within the *Inter RF Bandwidth gaps* is calculated as a cumulative sum of contributions from adjacent sub-blocks or *Base Station RF Bandwidth* on each side of the *Inter RF Bandwidth gap*.

NOTE 3: For operation with an E-UTRA 1,4 or 3 MHz carrier adjacent to the *Base Station RF Bandwidth edge* or the sub-block edge, the limits in table 4.3.2.2.1.3-5 apply for 0 MHz $\leq \Delta f < 0,15$ MHz.

NOTE 4: The requirement is not applicable when $\Delta f_{\text{max}} < 10$ MHz.

Table 4.3.2.2.1.3-5: Medium Range BS operating band unwanted emissions limits for operation in BC2 with E-UTRA 1,4 or 3 MHz carriers adjacent to the *Base Station RF Bandwidth edge* or the sub-block edge, $31 < P_{\text{rated,c,cell}} - 10 \times \log_{10}(N_{\text{TXU,countedpercell}}) \leq 38$ dBm

Frequency offset of measurement filter -3 dB point, Δf	Frequency offset of measurement filter centre frequency, f_{offset}	<i>basic limit</i> (notes 2 and 3)	<i>Measurement bandwidth</i>
$0 \text{ MHz} \leq \Delta f < 0,05 \text{ MHz}$	$0,015 \text{ MHz} \leq f_{\text{offset}} < 0,065 \text{ MHz}$	$P_{\text{rated,c,cell}} - 10 \times \log_{10}(N_{\text{TXU,countedpercell}}) - 36,5 - 60 \times (f_{\text{offset}} - 0,015) \text{ dBm}$	30 kHz
$0,05 \text{ MHz} \leq \Delta f < 0,15 \text{ MHz}$	$0,065 \text{ MHz} \leq f_{\text{offset}} < 0,165 \text{ MHz}$	$P_{\text{rated,c,cell}} - 10 \times \log_{10}(N_{\text{TXU,countedpercell}}) - 39,5 - 160 \times (f_{\text{offset}} - 0,065) \text{ dBm}$	30 kHz

NOTE 1: The limits in this table only apply for operation with an E-UTRA 1,4 or 3 MHz carrier adjacent to the *Base Station RF Bandwidth edge* or the sub-block edge.

NOTE 2: For *TAB connectors* supporting *non-contiguous spectrum* operation within any *operating band* the *basic limit* within *sub-block gaps* is calculated as a cumulative sum of contributions from adjacent sub-blocks on each side of the *sub-block gap*.

NOTE 3: For *multi-band TAB connectors* with *Inter RF Bandwidth gap* $< 2 \times \Delta f_{\text{OBUE}}$ MHz the *basic limit* within the *Inter RF Bandwidth gaps* is calculated as a cumulative sum of contributions from adjacent *sub-blocks* on each side of the *Inter RF Bandwidth gap*.

Table 4.3.2.2.1.3-6: Medium Range BS operating band unwanted emissions limits for operation in BC2 with E-UTRA 1,4 or 3 MHz carriers adjacent to the *Base Station RF Bandwidth edge* or the sub-block edge, $P_{\text{rated,c,cell}} - 10 \times \log_{10}(N_{\text{TXU,countedpercell}}) \leq 31$ dBm

Frequency offset of measurement filter -3 dB point, Δf	Frequency offset of measurement filter centre frequency, f_{offset}	<i>basic limit</i> (notes 2 and 3)	<i>Measurement bandwidth</i>
$0 \text{ MHz} \leq \Delta f < 0,05 \text{ MHz}$	$0,015 \text{ MHz} \leq f_{\text{offset}} < 0,065 \text{ MHz}$	$\text{Max}(-5,5 - 60 \times (f_{\text{offset}} - 0,015), -25,5) \text{ dBm}$	30 kHz
$0,05 \text{ MHz} \leq \Delta f < 0,15 \text{ MHz}$	$0,065 \text{ MHz} \leq f_{\text{offset}} < 0,165 \text{ MHz}$	$\text{Max}(-8,5 - 160 \times (f_{\text{offset}} - 0,065), -25,5) \text{ dBm}$	30 kHz

NOTE 1: The limits in this table only apply for operation with an E-UTRA 1,4 or 3 MHz carrier adjacent to the *Base Station RF Bandwidth edge* or the sub-block edge.

NOTE 2: For *TAB connectors* supporting *non-contiguous spectrum* operation within any *operating band* the *basic limit* within *sub-block gaps* is calculated as a cumulative sum of contributions from adjacent sub-blocks on each side of the *sub-block gap*.

NOTE 3: For *multi-band TAB connector* with *Inter RF Bandwidth gap* $< 2 \times \Delta f_{\text{OBUE}}$ MHz the *basic limit* within the *Inter RF Bandwidth gaps* is calculated as a cumulative sum of contributions from adjacent *sub-blocks* on each side of the *Inter RF Bandwidth gap*.

Table 4.3.2.2.1.3-7: Local Area BS operating band unwanted emissions limits for BC2

Frequency offset of measurement filter -3 dB point, Δf	Frequency offset of measurement filter centre frequency, f_{offset}	<i>basic limit</i> (notes 2 and 3)	<i>Measurement bandwidth</i>
$0 \text{ MHz} \leq \Delta f < 5 \text{ MHz}$ (note 1)	$0,05 \text{ MHz} \leq f_{\text{offset}} < 5,05 \text{ MHz}$	$-28,5 - \frac{7}{5} \times (f_{\text{offset}} - 0,05) \text{ dBm}$	100 kHz
$5 \text{ MHz} \leq \Delta f < \min(10 \text{ MHz}, \Delta f_{\text{max}})$	$5,05 \text{ MHz} \leq f_{\text{offset}} < \min(10,05 \text{ MHz}, f_{\text{offset,max}})$	-35,5 dBm	100 kHz
$10 \text{ MHz} \leq \Delta f \leq \Delta f_{\text{max}}$	$10,05 \text{ MHz} \leq f_{\text{offset}} < f_{\text{offset,max}}$	-37 dBm (note 4)	100 kHz

NOTE 1: For operation with an E-UTRA 1,4 or 3 MHz carrier adjacent to the *Base Station RF Bandwidth edge* or the sub-block edge, the limits in table 4.3.2.2.1.3-8 apply for $0 \text{ MHz} \leq \Delta f < 0,16 \text{ MHz}$.

NOTE 2: For *TAB connectors* supporting *non-contiguous spectrum* operation within any *operating band* the *basic limit* within *sub-block gaps* is calculated as a cumulative sum of contributions from adjacent sub-blocks on each side of the *sub-block gap*. Exception is $\Delta f \geq 10 \text{ MHz}$ from both adjacent sub-blocks on each side of the *sub-block gap*, where the *basic limit* within *sub-block gaps* shall be -37 dBm/100 kHz.

NOTE 3: For *multi-band TAB connectors* with *Inter RF Bandwidth gap* $< 2 \times \Delta f_{\text{OBUE}}$ MHz the *basic limit* within the *Inter RF Bandwidth gaps* is calculated as a cumulative sum of contributions from adjacent *sub-blocks* on each side of the *Inter RF Bandwidth gap*.

NOTE 4: The requirement is not applicable when $\Delta f_{\text{max}} < 10 \text{ MHz}$.

Table 4.3.2.2.1.3-8: Local Area BS operating band unwanted emissions limits for operation in BC2 with E-UTRA 1,4 or 3 MHz carriers adjacent to the *Base Station RF Bandwidth edge* or the sub-block edge

Frequency offset of measurement filter -3 dB point, Δf	Frequency offset of measurement filter centre frequency, f_{offset}	<i>basic limit</i> (notes 2, 3 and 4)	<i>Measurement bandwidth</i>
$0 \text{ MHz} \leq \Delta f < 0,05 \text{ MHz}$	$0,015 \text{ MHz} \leq f_{\text{offset}} < 0,065 \text{ MHz}$	$\text{Max}(-12,5 - 60 \times (f_{\text{offset}} - 0,015), -33,5) \text{ dBm}$	30 kHz
$0,05 \text{ MHz} \leq \Delta f < 0,16 \text{ MHz}$	$0,065 \text{ MHz} \leq f_{\text{offset}} < 0,175 \text{ MHz}$	$\text{Max}(-15,5 - 160 \times (f_{\text{offset}} - 0,065), -33,5) \text{ dBm}$	30 kHz

NOTE 1: The limits in this table only apply for operation with an E-UTRA 1,4 or 3 MHz carrier adjacent to the *Base Station RF Bandwidth edge* or the sub-block edge.

NOTE 2: For *TAB connectors* supporting *non-contiguous spectrum* operation within any *operating band* the *basic limit* within *sub-block gaps* is calculated as a cumulative sum of contributions from adjacent sub-blocks on each side of the *sub-block gap*.

NOTE 3: For *multi-band TAB connectors* with *Inter RF Bandwidth gap* $< 2 \times \Delta f_{\text{OBUe}}$ MHz the *basic limit* within the *Inter RF Bandwidth gaps* is calculated as a cumulative sum of contributions from adjacent *sub-blocks* on each side of the *Inter RF Bandwidth gap*.

NOTE 4: The requirement is not applicable when $\Delta f_{\text{max}} < 10 \text{ MHz}$.

4.3.2.2.1.4 Additional requirements

The limits in table 4.3.2.2.1.4-1 shall apply to *BS* operating in bands 77 and 78, for co-existence with FSS/FS. For each *TAB connector TX min cell group*, the power summation of the emissions at the *TAB connectors* of the *TAB connector TX min cell group* shall not exceed the *limits* in table 4.3.2.2.1.4-1.

Table 4.3.2.2.1.4-1: Additional operating band unwanted emissions limits for BS operating in bands 77 and 78

Frequency range	Limit	<i>Measurement bandwidth</i>
3 800 - 3 805 MHz	$\text{Min}(P_{\text{rated,t,cell}} - 40, 16) \text{ dBm}$	5 MHz
3 805 - 3 810 MHz	$\text{Min}(P_{\text{rated,t,cell}} - 43, 12) \text{ dBm}$	5 MHz
3 810 - 3 840 MHz	$\text{Min}(P_{\text{rated,t,cell}} - 43, 1) \text{ dBm}$	5 MHz
Above 3 840 MHz	-14 dBm	5 MHz

NOTE: $P_{\text{rated,t,cell}}$ is the total rated output power as a sum over all *TAB connectors* of the *TAB connector TX min cell group*.

The limits in table 4.3.2.2.1.4-2 shall apply to *BS* operating in band 40, for protection of systems above 2 400 MHz. For each *TAB connector TX min cell group*, the power summation of the emissions at the *TAB connectors* of the *TAB connector TX min cell group* shall not exceed the *limits* in table 4.3.2.2.1.4-2.

Table 4.3.2.2.1.4-2: Additional operating band unwanted emissions limits for BS operating in band 40

Frequency range	Total rated output power per cell $P_{\text{rated,t,cell}}$	Limit	<i>Measurement bandwidth</i>
Above 2 403 MHz	$P_{\text{rated,t,cell}} > 47 \text{ dBm}$	-13 dBm	5 MHz
	$33 \text{ dBm} < P_{\text{rated,t,cell}} \leq 47 \text{ dBm}$	$P_{\text{rated,t,TRP}} - 60 \text{ dBm}$	5 MHz
	$P_{\text{rated,t,cell}} \leq 33 \text{ dBm}$	-27 dBm	5 MHz

NOTE: $P_{\text{rated,t,cell}}$ is the total rated output power as a sum over all *TAB connectors* of the *TAB connector TX min cell group*.

NOTE 1: For a *BS* operating in band 20, additional limits for protection of DTT are described in clause 6.6.5.5.4.3 of ETSI TS 137 145-1 [2]. This statement is provided for information and does not have any impact on the conformance requirements or essential radio test suites in the present document.

NOTE 2: For a BS operating in band 32 within 1 452 MHz to 1 492 MHz, additional limits for protection are described in clause 6.6.5.5.4.6 of ETSI TS 137 145-1 [2]. This statement is provided for information and does not have any impact on the conformance requirements or essential radio test suites in the present document.

4.3.2.2.2 Limits for *single RAT E-UTRA operation*

4.3.2.2.2.1 General

The *operating band unwanted emission* requirements for *single RAT E-UTRA operation* are that for each *TAB connector TX min cell group* and each applicable *basic limit*, the power summation of the emissions at the *TAB connectors* of the *TAB connector TX min cell group* shall not exceed an AAS limit specified as the *basic limit* + $10\log_{10}(N_{\text{TXU, counted per cell}})$.

The requirements shall apply whatever the type of *TAB connector* is considered (single carrier or multi-carrier) and for all transmission modes foreseen by the manufacturer's specification. In addition, for *TAB connectors* operating in *non-contiguous spectrum*, the requirements apply inside any *sub-block gap*. In addition, for *multi-band TAB connectors* the requirements apply inside any *Inter RF Bandwidth gap*.

NOTE: The unwanted emission *basic limits* in the part of the *downlink operating band* that falls in the spurious domain are consistent with Recommendation ITU-R SM.329-12 [i.4].

Emissions shall use the *basic limits* specified in the tables below, where:

- Δf is the separation between the *channel edge* frequency and the nominal -3 dB point of the measuring filter closest to the carrier frequency.
- f_{offset} is the separation between the *channel edge* frequency and the centre of the measuring filter.
- $f_{\text{offset}_{\text{max}}}$ is the offset to the frequency Δf_{OBUE} outside the *downlink operating band*.
- Δf_{max} is equal to $f_{\text{offset}_{\text{max}}}$ minus half of the bandwidth of the measuring filter.

For *multi-band TAB connectors* inside any *Inter RF Bandwidth gaps* with $W_{\text{gap}} < 2 \times \Delta f_{\text{OBUE}}$ MHz, a combined *basic limit* shall be applied which is the cumulative sum of the *basic limits* specified at the *Base Station RF Bandwidth edges* on each side of the *Inter RF Bandwidth gap*. The *basic limit* for *Base Station RF Bandwidth edge* is specified in the clauses 4.3.2.2.2.2 to 4.3.2.2.2.6 below, where in this case:

- Δf is the separation between the *Base Station RF Bandwidth edge* frequency and the nominal -3 dB point of the measuring filter closest to the *Base Station RF Bandwidth edge*.
- f_{offset} is the separation between the *Base Station RF Bandwidth edge* frequency and the centre of the measuring filter.
- $f_{\text{offset}_{\text{max}}}$ is equal to the *Inter RF Bandwidth gap* minus half of the bandwidth of the measuring filter.
- Δf_{max} is equal to $f_{\text{offset}_{\text{max}}}$ minus half of the bandwidth of the measuring filter.

For *multi-band TAB connector* where multiple bands are mapped on the same *TAB connector*, the *operating band unwanted emission basic limits* apply also in a supported *operating band* without any carrier transmitted, in the case where there are carrier(s) transmitted in another supported *operating band*. In this case, no cumulative *basic limit* is applied in the *inter-band gap* between a supported *downlink operating band* with carrier(s) transmitted and a supported *downlink operating band* without any carrier transmitted; and:

- In case the *inter-band gap* between a supported *downlink operating band* with carrier(s) transmitted and a supported *downlink operating band* without any carrier transmitted is less than $2 \times \Delta f_{\text{OBUE}}$ MHz, $f_{\text{offset}_{\text{max}}}$ shall be the offset to the frequency Δf_{OBUE} outside the outermost edges of the two supported *downlink operating bands* and the *operating band unwanted emission* limit of the band where there are carriers transmitted, as defined in the tables of the present clause, shall apply across both downlink bands.
- In other cases, the *operating band unwanted emission basic limit* of the band where there are carriers transmitted, as defined in the tables of the present clause for the largest frequency offset (Δf_{max}), shall apply from Δf_{OBUE} below the lowest frequency, up to Δf_{OBUE} above the highest frequency of the supported *downlink operating band* without any carrier transmitted.

For a multicarrier E-UTRA *TAB connector* or a *TAB connector* configured for intra-band contiguous or non-contiguous *carrier aggregation* the definitions above apply to the lower edge of the carrier transmitted at the *lowest carrier* frequency and the upper edge of the carrier transmitted at the *highest carrier* frequency within a specified frequency band.

In addition inside any *sub-block gap* for *TAB connectors* operating in *non-contiguous spectrum*, a combined *basic limit* shall be applied which is the cumulative sum of the *basic limits* specified for the adjacent sub-blocks on each side of the *sub-block gap*. The *basic limit* for each sub-block is specified in the clauses 4.3.2.2.2.2 to 4.3.2.2.2.6 below, where in this case:

- Δf is the separation between the sub-block edge frequency and the nominal -3 dB point of the measuring filter closest to the sub-block edge.
- f_{offset} is the separation between the sub-block edge frequency and the centre of the measuring filter.
- $f_{\text{offset}_{\text{max}}}$ is equal to the *sub-block gap* bandwidth minus half of the bandwidth of the measuring filter.
- Δf_{max} is equal to $f_{\text{offset}_{\text{max}}}$ minus half of the bandwidth of the measuring filter.

4.3.2.2.2.2 Basic limits for Wide Area BS (bands 1, 3, 7, 8, 32, 33, 38, 65, 69)

Table 4.3.2.2.2-1: Wide Area BS operating band unwanted emissions limits for 1,4 MHz channel bandwidth (E-UTRA bands 3, 8, 65)

Frequency offset of measurement filter -3 dB point, Δf	Frequency offset of measurement filter centre frequency, f_{offset}	Basic limit (notes 1 and 2)	Measurement bandwidth
$0 \text{ MHz} \leq \Delta f < 0,05 \text{ MHz}$	$0,015 \text{ MHz} \leq f_{\text{offset}} < 0,065 \text{ MHz}$	$6,5 - 60 \times (f_{\text{offset}} - 0,015) \text{ dBm}$	30 kHz
$0,05 \text{ MHz} \leq \Delta f < 0,15 \text{ MHz}$	$0,065 \text{ MHz} \leq f_{\text{offset}} < 0,165 \text{ MHz}$	$3,5 - 160 \times (f_{\text{offset}} - 0,065) \text{ dBm}$	30 kHz
$0,15 \text{ MHz} \leq \Delta f < 0,2 \text{ MHz}$	$0,165 \text{ MHz} \leq f_{\text{offset}} < 0,215 \text{ MHz}$	-12,5 dBm	30 kHz
$0,2 \text{ MHz} \leq \Delta f < 1 \text{ MHz}$	$0,215 \text{ MHz} \leq f_{\text{offset}} < 1,015 \text{ MHz}$	$-12,5 - 15 \times (f_{\text{offset}} - 0,215) \text{ dBm}$	30 kHz
(note 3)	$1,015 \text{ MHz} \leq f_{\text{offset}} < 1,5 \text{ MHz}$	-24,5 dBm	30 kHz
$1 \text{ MHz} \leq \Delta f \leq 2,8 \text{ MHz}$	$1,5 \text{ MHz} \leq f_{\text{offset}} < 3,3 \text{ MHz}$	-11,5 dBm	1 MHz
$2,8 \text{ MHz} \leq \Delta f \leq \Delta f_{\text{max}}$	$3,3 \text{ MHz} \leq f_{\text{offset}} < f_{\text{offset}_{\text{max}}}$	-15 dBm (note 4)	1 MHz

NOTE 1: For *TAB connectors* supporting *non-contiguous spectrum* operation within any *operating band* the *basic limit* within *sub-block gaps* is calculated as a cumulative sum of contributions from adjacent sub-blocks on each side of the *sub-block gap*, where the contribution from the far-end *sub-block* shall be scaled according to the *measurement bandwidth* of the near-end *sub-block*. Exception is $\Delta f \geq 10 \text{ MHz}$ from both adjacent sub-blocks on each side of the *sub-block gap*, where the *basic limit* within *sub-block gaps* shall be -15 dBm/MHz.

NOTE 2: For *multi-band TAB connectors* with *Inter RF Bandwidth gap* $< 2 \times \Delta f_{\text{OBU E}} \text{ MHz}$ the *basic limit* within the *Inter RF Bandwidth gaps* is calculated as a cumulative sum of contributions from adjacent *sub-blocks* or *Base Station RF Bandwidth* on each side of the *Inter RF Bandwidth gap*, where the contribution from the far-end *sub-block* or *Base Station RF Bandwidth* shall be scaled according to the *measurement bandwidth* of the near-end *sub-block* or *Base Station RF Bandwidth*.

NOTE 3: This frequency range ensures that the range of values of f_{offset} is continuous.

NOTE 4: The requirement is not applicable when $\Delta f_{\text{max}} < 10 \text{ MHz}$.

Table 4.3.2.2.2-2: Wide Area BS operating band unwanted emissions limits for 3 MHz channel bandwidth (E-UTRA bands 3, 8, 65)

Frequency offset of measurement filter -3 dB point, Δf	Frequency offset of measurement filter centre frequency, f_{offset}	basic limit (notes 1 and 2)	Measurement bandwidth
$0 \text{ MHz} \leq \Delta f < 0,05 \text{ MHz}$	$0,015 \text{ MHz} \leq f_{\text{offset}} < 0,065 \text{ MHz}$	$6,5 - 60 \times (f_{\text{offset}} - 0,015) \text{ dBm}$	30 kHz
$0,05 \text{ MHz} \leq \Delta f < 0,15 \text{ MHz}$	$0,065 \text{ MHz} \leq f_{\text{offset}} < 0,165 \text{ MHz}$	$3,5 - 160 \times (f_{\text{offset}} - 0,065) \text{ dBm}$	30 kHz
$0,15 \text{ MHz} \leq \Delta f < 0,2 \text{ MHz}$	$0,165 \text{ MHz} \leq f_{\text{offset}} < 0,215 \text{ MHz}$	-12,5 dBm	30 kHz
$0,2 \text{ MHz} \leq \Delta f < 1 \text{ MHz}$	$0,215 \text{ MHz} \leq f_{\text{offset}} < 1,015 \text{ MHz}$	$-12,5 - 15 \times (f_{\text{offset}} - 0,215) \text{ dBm}$	30 kHz
(note 3)	$1,015 \text{ MHz} \leq f_{\text{offset}} < 1,5 \text{ MHz}$	-24,5 dBm	30 kHz
$1 \text{ MHz} \leq \Delta f \leq 6 \text{ MHz}$	$1,5 \text{ MHz} \leq f_{\text{offset}} < 6,5 \text{ MHz}$	-11,5 dBm	1 MHz
$6 \text{ MHz} \leq \Delta f \leq \Delta f_{\text{max}}$	$6,5 \text{ MHz} \leq f_{\text{offset}} < f_{\text{offset}_{\text{max}}}$	-15 dBm (note 4)	1 MHz
NOTE 1: For TAB connectors supporting non-contiguous spectrum operation within any operating band the basic limit within sub-block gaps is calculated as a cumulative sum of contributions from adjacent sub-blocks on each side of the sub-block gap, where the contribution from the far-end sub-block shall be scaled according to the measurement bandwidth of the near-end sub-block. Exception is $\Delta f \geq 10 \text{ MHz}$ from both adjacent sub-blocks on each side of the sub-block gap, where the basic limit within sub-block gaps shall be -15 dBm/MHz.			
NOTE 2: For multi-band TAB connectors with Inter RF Bandwidth gap $< 2 \times \Delta f_{\text{OBUE}}$ MHz the basic limit within the Inter RF Bandwidth gaps is calculated as a cumulative sum of contributions from adjacent sub-blocks or Base Station RF Bandwidth on each side of the Inter RF Bandwidth gap, where the contribution from the far-end sub-block or Base Station RF Bandwidth shall be scaled according to the measurement bandwidth of the near-end sub-block or Base Station RF Bandwidth.			
NOTE 3: This frequency range ensures that the range of values of f_{offset} is continuous.			
NOTE 4: The requirement is not applicable when $\Delta f_{\text{max}} < 10 \text{ MHz}$.			

Table 4.3.2.2.2-3: Wide Area BS operating band unwanted emissions limits for 5 MHz, 10 MHz, 15 MHz and 20 MHz channel bandwidth (E-UTRA bands 1, 3, 7, 8, 32, 33, 38, 65, 69)

Frequency offset of measurement filter -3 dB point, Δf	Frequency offset of measurement filter centre frequency, f_{offset}	Basic limit (notes 1 and 2)	Measurement bandwidth
$0 \text{ MHz} \leq \Delta f < 0,2 \text{ MHz}$	$0,015 \text{ MHz} \leq f_{\text{offset}} < 0,215 \text{ MHz}$	-12,5 dBm	30 kHz
$0,2 \text{ MHz} \leq \Delta f < 1 \text{ MHz}$	$0,215 \text{ MHz} \leq f_{\text{offset}} < 1,015 \text{ MHz}$	$-12,5 - 15 \times (f_{\text{offset}} - 0,215) \text{ dBm}$	30 kHz
(note 3)	$1,015 \text{ MHz} \leq f_{\text{offset}} < 1,5 \text{ MHz}$	-24,5 dBm	30 kHz
$1 \text{ MHz} \leq \Delta f \leq \min(10 \text{ MHz}, \Delta f_{\text{max}})$	$1,5 \text{ MHz} \leq f_{\text{offset}} < \min(10,5 \text{ MHz}, f_{\text{offset}_{\text{max}}})$	-11,5 dBm	1 MHz
$10 \text{ MHz} \leq \Delta f \leq \Delta f_{\text{max}}$	$10,5 \text{ MHz} \leq f_{\text{offset}} < f_{\text{offset}_{\text{max}}}$	-15 dBm (note 4)	1 MHz
NOTE 1: For TAB connectors supporting non-contiguous spectrum operation within any operating band the basic limit within sub-block gaps is calculated as a cumulative sum of contributions from adjacent sub-blocks on each side of the sub-block gap, where the contribution from the far-end sub-block shall be scaled according to the measurement bandwidth of the near-end sub-block. Exception is $\Delta f \geq 10 \text{ MHz}$ from both adjacent sub-blocks on each side of the sub-block gap, where the basic limit within sub-block gaps shall be -15 dBm/MHz.			
NOTE 2: For multi-band TAB connectors with Inter RF Bandwidth gap $< 2 \times \Delta f_{\text{OBUE}}$ MHz the basic limit within the Inter RF Bandwidth gaps is calculated as a cumulative sum of contributions from adjacent sub-blocks or Base Station RF Bandwidth on each side of the Inter RF Bandwidth gap, where the contribution from the far-end sub-block or Base Station RF Bandwidth shall be scaled according to the measurement bandwidth of the near-end sub-block or Base Station RF Bandwidth.			
NOTE 3: This frequency range ensures that the range of values of f_{offset} is continuous.			
NOTE 4: The requirement is not applicable when $\Delta f_{\text{max}} < 10 \text{ MHz}$.			

4.3.2.2.2.3

Basic limits for Wide Area BS (bands 7, 22, 38, 40, 41, 42, 43, 50, 69, 75)

Table 4.3.2.2.3-1: Wide Area BS operating band unwanted emissions limits for 1,4 MHz channel bandwidth (E-UTRA bands 7, 38, 40, 41, 50, 69, 75)

Frequency offset of measurement filter -3 dB point, Δf	Frequency offset of measurement filter centre frequency, f_{offset}	basic limit (notes 1 and 2)	Measurement bandwidth
$0 \text{ MHz} \leq \Delta f < 1,4 \text{ MHz}$	$0,05 \text{ MHz} \leq f_{\text{offset}} < 1,45 \text{ MHz}$	$+0,5 - \frac{10}{1,4} \times (f_{\text{offset}} - 0,05) \text{ dBm}$	100 kHz
$1,4 \text{ MHz} \leq \Delta f < 2,8 \text{ MHz}$	$1,45 \text{ MHz} \leq f_{\text{offset}} < 2,85 \text{ MHz}$	-9,5 dBm	100 kHz
$2,8 \text{ MHz} \leq \Delta f \leq \Delta f_{\text{max}}$	$3,3 \text{ MHz} \leq f_{\text{offset}} < f_{\text{offset}_{\text{max}}}$	-15 dBm (note 3)	1 MHz

NOTE 1: For TAB connectors supporting *non-contiguous spectrum* operation within any *operating band* the *basic limit* within *sub-block gaps* is calculated as a cumulative sum of contributions from adjacent sub-blocks on each side of the *sub-block gap*, where the contribution from the far-end *sub-block* shall be scaled according to the *measurement bandwidth* of the near-end *sub-block*. Exception is $\Delta f \geq 10$ MHz from both adjacent sub-blocks on each side of the *sub-block gap*, where the *basic limit* within *sub-block gaps* shall be -15 dBm/MHz.

NOTE 2: For *multi-band TAB connectors* with *Inter RF Bandwidth gap* $< 2\Delta f_{\text{OBUE}}$ MHz the *basic limit* within the *Inter RF Bandwidth gaps* is calculated as a cumulative sum of contributions from adjacent *sub-blocks* or *Base Station RF Bandwidth* on each side of the *Inter RF Bandwidth gap*, where the contribution from the far-end *sub-block* or *Base Station RF Bandwidth* shall be scaled according to the *measurement bandwidth* of the near-end *sub-block* or *Base Station RF Bandwidth*.

NOTE 3: The requirement is not applicable when $\Delta f_{\text{max}} < 10$ MHz.

Table 4.3.2.2.3-1a: Wide Area BS operating band unwanted emissions limits for 1,4 MHz channel bandwidth (E-UTRA bands 22, 42 and 43)

Frequency offset of measurement filter -3 dB point, Δf	Frequency offset of measurement filter centre frequency, f_{offset}	basic limit (notes 1 and 2)	Measurement bandwidth
$0 \text{ MHz} \leq \Delta f < 1,4 \text{ MHz}$	$0,05 \text{ MHz} \leq f_{\text{offset}} < 1,45 \text{ MHz}$	$+0,8 - \frac{10}{1,4} \times (f_{\text{offset}} - 0,05) \text{ dBm}$	100 kHz
$1,4 \text{ MHz} \leq \Delta f < 2,8 \text{ MHz}$	$1,45 \text{ MHz} \leq f_{\text{offset}} < 2,85 \text{ MHz}$	-9,2 dBm	100 kHz
$2,8 \text{ MHz} \leq \Delta f \leq \Delta f_{\text{max}}$	$3,3 \text{ MHz} \leq f_{\text{offset}} < f_{\text{offset}_{\text{max}}}$	-15 dBm (note 3)	1 MHz

NOTE 1: For TAB connectors supporting *non-contiguous spectrum* operation within any *operating band* the *basic limit* within *sub-block gaps* is calculated as a cumulative sum of contributions from adjacent sub-blocks on each side of the *sub-block gap*, where the contribution from the far-end *sub-block* shall be scaled according to the *measurement bandwidth* of the near-end *sub-block*. Exception is $\Delta f \geq 10$ MHz from both adjacent sub-blocks on each side of the *sub-block gap*, where the *basic limit* within *sub-block gaps* shall be -15 dBm/MHz.

NOTE 2: For *multi-band TAB connectors* with *Inter RF Bandwidth gap* $< 2 \times \Delta f_{\text{OBUE}}$ MHz the *basic limit* within the *Inter RF Bandwidth gaps* is calculated as a cumulative sum of contributions from adjacent *sub-blocks* or *Base Station RF Bandwidth* on each side of the *Inter RF Bandwidth gap*, where the contribution from the far-end *sub-block* or *Base Station RF Bandwidth* shall be scaled according to the *measurement bandwidth* of the near-end *sub-block* or *Base Station RF Bandwidth*.

NOTE 3: The requirement is not applicable when $\Delta f_{\text{max}} < 10$ MHz.

Table 4.3.2.2.3-2: Wide Area BS operating band unwanted emissions limits for 3 MHz channel bandwidth (E-UTRA bands 7, 38, 40, 41, 50, 69, 75)

Frequency offset of measurement filter -3 dB point, Δf	Frequency offset of measurement filter centre frequency, f_{offset}	basic limit (notes 1 and 2)	Measurement bandwidth
$0 \text{ MHz} \leq \Delta f < 3 \text{ MHz}$	$0,05 \text{ MHz} \leq f_{\text{offset}} < 3,05 \text{ MHz}$	$-3,5 - \frac{10}{3} \times (f_{\text{offset}} - 0,05) \text{ dBm}$	100 kHz
$3 \text{ MHz} \leq \Delta f < 6 \text{ MHz}$	$3,05 \text{ MHz} \leq f_{\text{offset}} < 6,05 \text{ MHz}$	-13,5 dBm	100 kHz
$6 \text{ MHz} \leq \Delta f \leq \Delta f_{\text{max}}$	$6,5 \text{ MHz} \leq f_{\text{offset}} < f_{\text{offset}_{\text{max}}}$	-15 dBm (note 3)	1 MHz

NOTE 1: For TAB connectors supporting *non-contiguous spectrum* operation within any *operating band* the *basic limit* within *sub-block gaps* is calculated as a cumulative sum of contributions from adjacent sub-blocks on each side of the *sub-block gap*, where the contribution from the far-end *sub-block* shall be scaled according to the *measurement bandwidth* of the near-end *sub-block*. Exception is $\Delta f \geq 10$ MHz from both adjacent sub-blocks on each side of the *sub-block gap*, where the *basic limit* within *sub-block gaps* shall be -15 dBm/MHz.

NOTE 2: For *multi-band TAB connectors* with *Inter RF Bandwidth gap* $< 2 \times \Delta f_{\text{OBUe}}$ MHz the *basic limit* within the *Inter RF Bandwidth gaps* is calculated as a cumulative sum of contributions from adjacent *sub-blocks* or *Base Station RF Bandwidth* on each side of the *Inter RF Bandwidth gap*, where the contribution from the far-end *sub-block* or *Base Station RF Bandwidth* shall be scaled according to the *measurement bandwidth* of the near-end *sub-block* or *Base Station RF Bandwidth*.

NOTE 3: The requirement is not applicable when $\Delta f_{\text{max}} < 10$ MHz.

Table 4.3.2.2.3-2a: Wide Area BS operating band unwanted emissions limits for 3 MHz channel bandwidth (E-UTRA bands 22, 42 and 43)

Frequency offset of measurement filter -3 dB point, Δf	Frequency offset of measurement filter centre frequency, f_{offset}	basic limit (notes 1 and 2)	Measurement bandwidth
$0 \text{ MHz} \leq \Delta f < 3 \text{ MHz}$	$0,05 \text{ MHz} \leq f_{\text{offset}} < 3,05 \text{ MHz}$	$-3,2 - \frac{10}{3} \times (f_{\text{offset}} - 0,05) \text{ dBm}$	100 kHz
$3 \text{ MHz} \leq \Delta f < 6 \text{ MHz}$	$3,05 \text{ MHz} \leq f_{\text{offset}} < 6,05 \text{ MHz}$	-13,2 dBm	100 kHz
$6 \text{ MHz} \leq \Delta f \leq \Delta f_{\text{max}}$	$6,5 \text{ MHz} \leq f_{\text{offset}} < f_{\text{offset}_{\text{max}}}$	-15 dBm (note 3)	1 MHz

NOTE 1: For TAB connectors supporting *non-contiguous spectrum* operation within any *operating band* the *basic limit* within *sub-block gaps* is calculated as a cumulative sum of contributions from adjacent sub-blocks on each side of the *sub-block gap*, where the contribution from the far-end *sub-block* shall be scaled according to the *measurement bandwidth* of the near-end *sub-block*. Exception is $\Delta f \geq 10$ MHz from both adjacent sub-blocks on each side of the *sub-block gap*, where the *basic limit* within *sub-block gaps* shall be -15 dBm/MHz.

NOTE 2: For *multi-band TAB connectors* with *Inter RF Bandwidth gap* $< 2 \times \Delta f_{\text{OBUe}}$ MHz the *basic limit* within the *Inter RF Bandwidth gaps* is calculated as a cumulative sum of contributions from adjacent *sub-blocks* or *Base Station RF Bandwidth* on each side of the *Inter RF Bandwidth gap*, where the contribution from the far-end *sub-block* or *Base Station RF Bandwidth* shall be scaled according to the *measurement bandwidth* of the near-end *sub-block* or *Base Station RF Bandwidth*.

NOTE 3: The requirement is not applicable when $\Delta f_{\text{max}} < 10$ MHz.

Table 4.3.2.2.3-3: Wide Area BS operating band unwanted emissions limits for 5 MHz, 10 MHz, 15 MHz and 20 MHz channel bandwidth (E-UTRA bands 7, 38, 40, 41, 50, 69, 75)

Frequency offset of measurement filter -3 dB point, Δf	Frequency offset of measurement filter centre frequency, f_{offset}	basic limit (notes 1 and 2)	Measurement bandwidth
$0 \text{ MHz} \leq \Delta f < 5 \text{ MHz}$	$0,05 \text{ MHz} \leq f_{\text{offset}} < 5,05 \text{ MHz}$	$-5,5 - \frac{7}{5} \times (f_{\text{offset}} - 0,05) \text{ dBm}$	100 kHz
$5 \text{ MHz} \leq \Delta f < \min(10 \text{ MHz}, \Delta f_{\text{max}})$	$5,05 \text{ MHz} \leq f_{\text{offset}} < \min(10,05 \text{ MHz}, f_{\text{offset}_{\text{max}}})$	-12,5 dBm	100 kHz
$10 \text{ MHz} \leq \Delta f \leq \Delta f_{\text{max}}$	$10,5 \text{ MHz} \leq f_{\text{offset}} < f_{\text{offset}_{\text{max}}}$	-15 dBm (note 3)	1 MHz
NOTE 1: For TAB connectors supporting <i>non-contiguous spectrum</i> operation within any <i>operating band</i> the <i>basic limit</i> within <i>sub-block gaps</i> is calculated as a cumulative sum of contributions from adjacent sub-blocks on each side of the <i>sub-block gap</i> , where the contribution from the far-end <i>sub-block</i> shall be scaled according to the <i>measurement bandwidth</i> of the near-end <i>sub-block</i> . Exception is $\Delta f \geq 10 \text{ MHz}$ from both adjacent sub-blocks on each side of the <i>sub-block gap</i> , where the <i>basic limit</i> within <i>sub-block gaps</i> shall be -15 dBm/MHz.			
NOTE 2: For <i>multi-band TAB connectors</i> with <i>Inter RF Bandwidth gap</i> $< 2 \times \Delta f_{\text{OBUe}}$ MHz the <i>basic limit</i> within the <i>Inter RF Bandwidth gaps</i> is calculated as a cumulative sum of contributions from adjacent <i>sub-blocks</i> or <i>Base Station RF Bandwidth</i> on each side of the <i>Inter RF Bandwidth gap</i> , where the contribution from the far-end <i>sub-block</i> or <i>Base Station RF Bandwidth</i> shall be scaled according to the <i>measurement bandwidth</i> of the near-end <i>sub-block</i> or <i>Base Station RF Bandwidth</i> .			
NOTE 3: The requirement is not applicable when $\Delta f_{\text{max}} < 10 \text{ MHz}$.			

Table 4.3.2.2.3-3a: Wide Area BS operating band unwanted emissions limits for 5 MHz, 10 MHz, 15 MHz and 20 MHz channel bandwidth (E-UTRA bands 22, 42 and 43)

Frequency offset of measurement filter -3 dB point, Δf	Frequency offset of measurement filter centre frequency, f_{offset}	basic limit (notes 1 and 2)	Measurement bandwidth
$0 \text{ MHz} \leq \Delta f < 5 \text{ MHz}$	$0,05 \text{ MHz} \leq f_{\text{offset}} < 5,05 \text{ MHz}$	$-5,2 - \frac{7}{5} \times (f_{\text{offset}} - 0,05) \text{ dBm}$	100 kHz
$5 \text{ MHz} \leq \Delta f < \min(10 \text{ MHz}, \Delta f_{\text{max}})$	$5,05 \text{ MHz} \leq f_{\text{offset}} < \min(10,05 \text{ MHz}, f_{\text{offset}_{\text{max}}})$	-12,2 dBm	100 kHz
$10 \text{ MHz} \leq \Delta f \leq \Delta f_{\text{max}}$	$10,5 \text{ MHz} \leq f_{\text{offset}} < f_{\text{offset}_{\text{max}}}$	-15 dBm (note 3)	1 MHz
NOTE 1: For TAB connectors supporting <i>non-contiguous spectrum</i> operation within any <i>operating band</i> the <i>basic limit</i> within <i>sub-block gaps</i> is calculated as a cumulative sum of contributions from adjacent sub-blocks on each side of the <i>sub-block gap</i> , where the contribution from the far-end <i>sub-block</i> shall be scaled according to the <i>measurement bandwidth</i> of the near-end <i>sub-block</i> . Exception is $\Delta f \geq 10 \text{ MHz}$ from both adjacent sub-blocks on each side of the <i>sub-block gap</i> , where the <i>basic limit</i> within <i>sub-block gaps</i> shall be -15 dBm/MHz.			
NOTE 2: For <i>multi-band TAB connectors</i> with <i>Inter RF Bandwidth gap</i> $< 2 \times \Delta f_{\text{OBUe}}$ MHz the <i>basic limit</i> within the <i>Inter RF Bandwidth gaps</i> is calculated as a cumulative sum of contributions from adjacent <i>sub-blocks</i> or <i>Base Station RF Bandwidth</i> on each side of the <i>Inter RF Bandwidth gap</i> , where the contribution from the far-end <i>sub-block</i> or <i>Base Station RF Bandwidth</i> shall be scaled according to the <i>measurement bandwidth</i> of the near-end <i>sub-block</i> or <i>Base Station RF Bandwidth</i> .			
NOTE 3: The requirement is not applicable when $\Delta f_{\text{max}} < 10 \text{ MHz}$.			

4.3.2.2.4

Basic limits for Wide Area BS (bands 20, 28, 31, 67, 68, 72, 87, 88)

Table 4.3.2.2.4-1: Wide Area BS operating band unwanted emissions limits for 1,4 MHz channel bandwidth (E-UTRA band 20, 28, 31, 67, 68, 72, 87, 88)

Frequency offset of measurement filter -3 dB point, Δf	Frequency offset of measurement filter centre frequency, f_{offset}	basic limit (notes 1 and 2)	Measurement bandwidth
$0 \text{ MHz} \leq \Delta f < 1,4 \text{ MHz}$	$0,05 \text{ MHz} \leq f_{\text{offset}} < 1,45 \text{ MHz}$	$+0,5 - \frac{10}{1,4} \times (f_{\text{offset}} - 0,05) \text{ dBm}$	100 kHz
$1,4 \text{ MHz} \leq \Delta f < 2,8 \text{ MHz}$	$1,45 \text{ MHz} \leq f_{\text{offset}} < 2,85 \text{ MHz}$	-9,5 dBm	100 kHz
$2,8 \text{ MHz} \leq \Delta f \leq \Delta f_{\text{max}}$	$2,85 \text{ MHz} \leq f_{\text{offset}} < f_{\text{offset}_{\text{max}}}$	-16 dBm (note 3)	100 kHz

NOTE 1: For TAB connectors supporting *non-contiguous spectrum* operation within any *operating band* the *basic limit* within *sub-block gaps* is calculated as a cumulative sum of contributions from adjacent sub-blocks on each side of the *sub-block gap*. Exception is $\Delta f \geq 10 \text{ MHz}$ from both adjacent sub-blocks on each side of the *sub-block gap*, where the *basic limit* within *sub-block gaps* shall be -16 dBm/100 kHz.

NOTE 2: For *multi-band TAB connectors* with *Inter RF Bandwidth gap* $< 2 \times \Delta f_{\text{OBUE}}$ MHz the *basic limit* within the *Inter RF Bandwidth gaps* is calculated as a cumulative sum of contributions from adjacent *sub-blocks* or *Base Station RF Bandwidth* on each side of the *Inter RF Bandwidth gap*.

NOTE 3: The requirement is not applicable when $\Delta f_{\text{max}} < 10 \text{ MHz}$.

Table 4.3.2.2.4-2: Wide Area BS operating band unwanted emissions limits for 3 MHz channel bandwidth (E-UTRA band 20, 28, 31, 67, 68, 72, 87, 88)

Frequency offset of measurement filter -3 dB point, Δf	Frequency offset of measurement filter centre frequency, f_{offset}	basic limit (notes 1 and 2)	Measurement bandwidth
$0 \text{ MHz} \leq \Delta f < 3 \text{ MHz}$	$0,05 \text{ MHz} \leq f_{\text{offset}} < 3,05 \text{ MHz}$	$-3,5 - \frac{10}{3} \times (f_{\text{offset}} - 0,05) \text{ dBm}$	100 kHz
$3 \text{ MHz} \leq \Delta f < 6 \text{ MHz}$	$3,05 \text{ MHz} \leq f_{\text{offset}} < 6,05 \text{ MHz}$	-13,5 dBm	100 kHz
$6 \text{ MHz} \leq \Delta f \leq \Delta f_{\text{max}}$	$6,05 \text{ MHz} \leq f_{\text{offset}} < f_{\text{offset}_{\text{max}}}$	-16 dBm (note 3)	100 kHz

NOTE 1: For TAB connectors supporting *non-contiguous spectrum* operation within any *operating band* the *basic limit* within *sub-block gaps* is calculated as a cumulative sum of contributions from adjacent sub-blocks on each side of the *sub-block gap*. Exception is $\Delta f \geq 10 \text{ MHz}$ from both adjacent sub-blocks on each side of the *sub-block gap*, where the *basic limit* within *sub-block gaps* shall be -16 dBm/100 kHz.

NOTE 2: For *multi-band TAB connectors* with *Inter RF Bandwidth gap* $< 2 \times \Delta f_{\text{OBUE}}$ MHz the *basic limit* within the *Inter RF Bandwidth gaps* is calculated as a cumulative sum of contributions from adjacent *sub-blocks* or *Base Station RF Bandwidth* on each side of the *Inter RF Bandwidth gap*.

NOTE 3: The requirement is not applicable when $\Delta f_{\text{max}} < 10 \text{ MHz}$.

Table 4.3.2.2.4-3: Wide Area BS operating band unwanted emissions limits for 5 MHz, 10 MHz, 15 MHz and 20 MHz channel bandwidth (E-UTRA band 20, 28, 31, 67, 68, 72, 87, 88)

Frequency offset of measurement filter -3 dB point, Δf	Frequency offset of measurement filter centre frequency, f_{offset}	basic limit (notes 1 and 2)	Measurement bandwidth
$0 \text{ MHz} \leq \Delta f < 5 \text{ MHz}$	$0,05 \text{ MHz} \leq f_{\text{offset}} < 5,05 \text{ MHz}$	$-5,5 - \frac{7}{5} \times (f_{\text{offset}} - 0,05) \text{ dBm}$	100 kHz
$5 \text{ MHz} \leq \Delta f < 10 \text{ MHz}$	$5,05 \text{ MHz} \leq f_{\text{offset}} < 10,05 \text{ MHz}$	-12,5 dBm	100 kHz
$10 \text{ MHz} \leq \Delta f \leq \Delta f_{\text{max}}$	$10,05 \text{ MHz} \leq f_{\text{offset}} < f_{\text{offset}_{\text{max}}}$	-16 dBm (note 3)	100 kHz

NOTE 1: For TAB connectors supporting *non-contiguous spectrum* operation within any *operating band* the *basic limit* within *sub-block gaps* is calculated as a cumulative sum of contributions from adjacent sub-blocks on each side of the *sub-block gap*. Exception is $\Delta f \geq 10 \text{ MHz}$ from both adjacent sub-blocks on each side of the *sub-block gap*, where the *basic limit* within *sub-block gaps* shall be -16 dBm/100 kHz.

NOTE 2: For *multi-band TAB connectors* with *Inter RF Bandwidth gap* $< 2 \times \Delta f_{\text{OBUE}}$ MHz the *basic limit* within the *Inter RF Bandwidth gaps* is calculated as a cumulative sum of contributions from adjacent *sub-blocks* or *Base Station RF Bandwidth* on each side of the *Inter RF Bandwidth gap*.

NOTE 3: The requirement is not applicable when $\Delta f_{\text{max}} < 10 \text{ MHz}$.

4.3.2.2.2.5

Basic limits for Medium Range BS

Table 4.3.2.2.2.5-1: Medium Range BS operating band unwanted emissions limits for 1,4 MHz channel bandwidth, $31 < P_{\text{rated,c,cell}} - 10 \times \log_{10}(N_{\text{TXU,countedpercell}}) \leq 38$ dBm (E-UTRA bands ≤ 3 GHz)

Frequency offset of measurement filter -3 dB point, Δf	Frequency offset of measurement filter centre frequency, f_{offset}	basic limit (notes 1 and 2)	Measurement bandwidth
$0 \text{ MHz} \leq \Delta f < 1,4 \text{ MHz}$	$0,05 \text{ MHz} \leq f_{\text{offset}} < 1,45 \text{ MHz}$	$P_{\text{rated,c,cell}} - 10 \times \log_{10}(N_{\text{TXU,countedpercell}}) - 43,5 - \frac{10}{1,4} \times (f_{\text{offset}} - 0,05) \text{ dBm}$	100 kHz
$1,4 \text{ MHz} \leq \Delta f < 2,8 \text{ MHz}$	$1,45 \text{ MHz} \leq f_{\text{offset}} < 2,85 \text{ MHz}$	$P_{\text{rated,c,cell}} - 10 \times \log_{10}(N_{\text{TXU,countedpercell}}) - 53,5 \text{ dBm}$	100 kHz
$2,8 \text{ MHz} \leq \Delta f \leq \Delta f_{\text{max}}$	$2,85 \text{ MHz} \leq f_{\text{offset}} < f_{\text{offsetmax}}$	-25 dBm (note 3)	100 kHz
NOTE 1: For TAB connectors supporting non-contiguous spectrum operation within any operating band the basic limit within sub-block gaps is calculated as a cumulative sum of contributions from adjacent sub-blocks on each side of the sub-block gap. Exception is $\Delta f \geq 10$ MHz from both adjacent sub-blocks on each side of the sub-block gap, where the basic limit within sub-block gaps shall be -25 dBm/100 kHz.			
NOTE 2: For multi-band TAB connectors with Inter RF Bandwidth gap $< 2 \times \Delta f_{\text{OBUE}}$ MHz the basic limit within the Inter RF Bandwidth gaps is calculated as a cumulative sum of contributions from adjacent sub-blocks or Base Station RF Bandwidth on each side of the Inter RF Bandwidth gap.			
NOTE 3: The requirement is not applicable when $\Delta f_{\text{max}} < 10$ MHz.			

Table 4.3.2.2.2.5-2: Medium Range BS operating band unwanted emissions limits for 1,4 MHz channel bandwidth, $31 < P_{\text{rated,c,cell}} - 10 \times \log_{10}(N_{\text{TXU,countedpercell}}) \leq 38$ dBm (E-UTRA bands > 3 GHz)

Frequency offset of measurement filter -3 dB point, Δf	Frequency offset of measurement filter centre frequency, f_{offset}	basic limit (notes 1 and 2)	Measurement bandwidth
$0 \text{ MHz} \leq \Delta f < 1,4 \text{ MHz}$	$0,05 \text{ MHz} \leq f_{\text{offset}} < 1,45 \text{ MHz}$	$P_{\text{rated,c,cell}} - 10 \times \log_{10}(N_{\text{TXU,countedpercell}}) - 43,2 - \frac{10}{1,4} \times (f_{\text{offset}} - 0,05) \text{ dBm}$	100 kHz
$1,4 \text{ MHz} \leq \Delta f < 2,8 \text{ MHz}$	$1,45 \text{ MHz} \leq f_{\text{offset}} < 2,85 \text{ MHz}$	$P_{\text{rated,c,cell}} - 10 \times \log_{10}(N_{\text{TXU,countedpercell}}) - 53,2 \text{ dBm}$	100 kHz
$2,8 \text{ MHz} \leq \Delta f \leq \Delta f_{\text{max}}$	$2,85 \text{ MHz} \leq f_{\text{offset}} < f_{\text{offsetmax}}$	-25 dBm (note 3)	100 kHz
NOTE 1: For TAB connectors supporting non-contiguous spectrum operation within any operating band the basic limit within sub-block gaps is calculated as a cumulative sum of contributions from adjacent sub-blocks on each side of the sub-block gap. Exception is $\Delta f \geq 10$ MHz from both adjacent sub-blocks on each side of the sub-block gap, where the basic limit within sub-block gaps shall be -25 dBm/100 kHz.			
NOTE 2: For multi-band TAB connectors with Inter RF Bandwidth gap basic limit $< 2 \times \Delta f_{\text{OBUE}}$ MHz the basic limit within the Inter RF Bandwidth gaps is calculated as a cumulative sum of contributions from adjacent sub-blocks or Base Station RF Bandwidth on each side of the Inter RF Bandwidth gap.			
NOTE 3: The requirement is not applicable when $\Delta f_{\text{max}} < 10$ MHz.			

Table 4.3.2.2.5-3: Medium Range BS operating band unwanted emissions limits for 1,4 MHz channel bandwidth, $P_{\text{rated,c,cell}} - 10 \times \log_{10}(N_{\text{TXU,countedpercell}}) \leq 31$ dBm (E-UTRA bands ≤ 3 GHz)

Frequency offset of measurement filter -3 dB point, Δf	Frequency offset of measurement filter centre frequency, f_{offset}	basic limit (notes 1 and 2)	Measurement bandwidth
$0 \text{ MHz} \leq \Delta f < 1,4 \text{ MHz}$	$0,05 \text{ MHz} \leq f_{\text{offset}} < 1,45 \text{ MHz}$	$-12,5 - \frac{10}{1,4} \times (f_{\text{offset}} - 0,05) \text{ dBm}$	100 kHz
$1,4 \text{ MHz} \leq \Delta f < 2,8 \text{ MHz}$	$1,45 \text{ MHz} \leq f_{\text{offset}} < 2,85 \text{ MHz}$	-22,5 dBm	100 kHz
$2,8 \text{ MHz} \leq \Delta f \leq \Delta f_{\text{max}}$	$2,85 \text{ MHz} \leq f_{\text{offset}} < f_{\text{offsetmax}}$	-25 dBm (note 3)	100 kHz

NOTE 1: For TAB connectors supporting *non-contiguous spectrum* operation within any *operating band* the *basic limit* within *sub-block gaps* is calculated as a cumulative sum of contributions from adjacent sub-blocks on each side of the *sub-block gap*. Exception is $\Delta f \geq 10$ MHz from both adjacent sub-blocks on each side of the *sub-block gap*, where the *basic limit* within *sub-block gaps* shall be -25 dBm/100 kHz.

NOTE 2: For BS a *multi-band TAB connector* with *Inter RF Bandwidth gap* $< 2 \times \Delta f_{\text{fobUE}}$ MHz the *basic limit* within the *Inter RF Bandwidth gaps* is calculated as a cumulative sum of contributions from adjacent *sub-blocks* or *Base Station RF Bandwidth* on each side of the *Inter RF Bandwidth gap*.

NOTE 3: The requirement is not applicable when $\Delta f_{\text{max}} < 10$ MHz.

Table 4.3.2.2.5-4: Medium Range BS operating band unwanted emissions limits for 1,4 MHz channel bandwidth, $P_{\text{rated,c,cell}} - 10 \times \log_{10}(N_{\text{TXU,countedpercell}}) \leq 31$ dBm (E-UTRA bands > 3 GHz)

Frequency offset of measurement filter -3 dB point, Δf	Frequency offset of measurement filter centre frequency, f_{offset}	basic limit (notes 1 and 2)	Measurement bandwidth
$0 \text{ MHz} \leq \Delta f < 1,4 \text{ MHz}$	$0,05 \text{ MHz} \leq f_{\text{offset}} < 1,45 \text{ MHz}$	$-12,2 - \frac{10}{1,4} \times (f_{\text{offset}} - 0,05) \text{ dBm}$	100 kHz
$1,4 \text{ MHz} \leq \Delta f < 2,8 \text{ MHz}$	$1,45 \text{ MHz} \leq f_{\text{offset}} < 2,85 \text{ MHz}$	-22,2 dBm	100 kHz
$2,8 \text{ MHz} \leq \Delta f \leq \Delta f_{\text{max}}$	$2,85 \text{ MHz} \leq f_{\text{offset}} < f_{\text{offsetmax}}$	-25 dBm (note 3)	100 kHz

NOTE 1: For TAB connectors supporting *non-contiguous spectrum* operation within any *operating band* the *basic limit* within *sub-block gaps* is calculated as a cumulative sum of contributions from adjacent sub-blocks on each side of the *sub-block gap*. Exception is $\Delta f \geq 10$ MHz from both adjacent sub-blocks on each side of the *sub-block gap*, where the *basic limit* within *sub-block gaps* shall be -25 dBm/100 kHz.

NOTE 2: For *multi-band TAB connectors* with *Inter RF Bandwidth gap* $< 2 \times \Delta f_{\text{fobUE}}$ MHz the *basic limit* within the *Inter RF Bandwidth gaps* is calculated as a cumulative sum of contributions from adjacent *sub-blocks* or *Base Station RF Bandwidth* on each side of the *Inter RF Bandwidth gap*.

NOTE 3: The requirement is not applicable when $\Delta f_{\text{max}} < 10$ MHz.

Table 4.3.2.2.5-5: Medium Range BS operating band unwanted emissions limits for 3 MHz channel bandwidth, $31 < P_{\text{rated,c,cell}} - 10 \times \log_{10}(N_{\text{TXU,countedpercell}}) \leq 38$ dBm (E-UTRA bands ≤ 3 GHz)

Frequency offset of measurement filter -3 dB point, Δf	Frequency offset of measurement filter centre frequency, f_{offset}	<i>basic limit</i> (notes 1 and 2)	<i>Measurement bandwidth</i>
$0 \text{ MHz} \leq \Delta f < 3 \text{ MHz}$	$0,05 \text{ MHz} \leq f_{\text{offset}} < 3,05 \text{ MHz}$	$P_{\text{rated,c,cell}} - 10 \times \log_{10}(N_{\text{TXU,countedpercell}}) - 47,5 - \frac{10}{3} \times (f_{\text{offset}} - 0,05) \text{ dBm}$	100 kHz
$3 \text{ MHz} \leq \Delta f < 6 \text{ MHz}$	$3,05 \text{ MHz} \leq f_{\text{offset}} < 6,05 \text{ MHz}$	$P_{\text{rated,c,cell}} - 10 \times \log_{10}(N_{\text{TXU,countedpercell}}) - 57,5 \text{ dBm}$	100 kHz
$6 \text{ MHz} \leq \Delta f \leq \Delta f_{\text{max}}$	$6,05 \text{ MHz} \leq f_{\text{offset}} < f_{\text{offsetmax}}$	$\text{Min}(P_{\text{rated,c,cell}} - 10 \times \log_{10}(N_{\text{TXU,countedpercell}}) - 59, -25) \text{ dBm}$ (note 3)	100 kHz
<p>NOTE 1: For <i>TAB connectors</i> supporting <i>non-contiguous spectrum</i> operation within any <i>operating band</i> the <i>basic limit</i> within <i>sub-block gaps</i> is calculated as a cumulative sum of contributions from adjacent sub-blocks on each side of the <i>sub-block gap</i>. Exception is $\Delta f \geq 10$ MHz from both adjacent sub-blocks on each side of the <i>sub-block gap</i>, where the <i>basic limit</i> within <i>sub-block gaps</i> shall be $\text{Min}(P_{\text{rated,c,cell}} - 10 \times \log_{10}(N_{\text{TXU,countedpercell}}) - 59 \text{ dB}, -25 \text{ dBm})/100 \text{ kHz}$.</p> <p>NOTE 2: For <i>multi-band TAB connectors</i> with <i>Inter RF Bandwidth gap</i> $< 2 \times \Delta f_{\text{OBUE}}$ MHz the <i>basic limit</i> within the <i>Inter RF Bandwidth gaps</i> is calculated as a cumulative sum of contributions from adjacent <i>sub-blocks</i> or <i>Base Station RF Bandwidth</i> on each side of the <i>Inter RF Bandwidth gap</i>.</p> <p>NOTE 3: The requirement is not applicable when $\Delta f_{\text{max}} < 10$ MHz.</p>			

Table 4.3.2.2.5-6: Medium Range BS operating band unwanted emissions limits for 3 MHz channel bandwidth, $31 < P_{\text{rated,c,cell}} - 10 \times \log_{10}(N_{\text{TXU,countedpercell}}) \leq 38$ dBm (E-UTRA bands > 3 GHz)

Frequency offset of measurement filter -3 dB point, Δf	Frequency offset of measurement filter centre frequency, f_{offset}	<i>basic limit</i> (notes 1 and 2)	<i>Measurement bandwidth</i>
$0 \text{ MHz} \leq \Delta f < 3 \text{ MHz}$	$0,05 \text{ MHz} \leq f_{\text{offset}} < 3,05 \text{ MHz}$	$P_{\text{rated,c,cell}} - 10 \times \log_{10}(N_{\text{TXU,countedpercell}}) - 47,2 - \frac{10}{3} \times (f_{\text{offset}} - 0,05) \text{ dBm}$	100 kHz
$3 \text{ MHz} \leq \Delta f < 6 \text{ MHz}$	$3,05 \text{ MHz} \leq f_{\text{offset}} < 6,05 \text{ MHz}$	$P_{\text{rated,c,cell}} - 10 \times \log_{10}(N_{\text{TXU,countedpercell}}) - 57,2 \text{ dBm}$	100 kHz
$6 \text{ MHz} \leq \Delta f \leq \Delta f_{\text{max}}$	$6,05 \text{ MHz} \leq f_{\text{offset}} < f_{\text{offsetmax}}$	$\text{Min}(P_{\text{rated,c,cell}} - 10 \times \log_{10}(N_{\text{TXU,countedpercell}}) - 59, -25) \text{ dBm}$ (note 3)	100 kHz
<p>NOTE 1: For <i>TAB connectors</i> supporting <i>non-contiguous spectrum</i> operation within any <i>operating band</i> the <i>basic limit</i> within <i>sub-block gaps</i> is calculated as a cumulative sum of contributions from adjacent sub-blocks on each side of the <i>sub-block gap</i>. Exception is $\Delta f \geq 10$ MHz from both adjacent sub-blocks on each side of the <i>sub-block gap</i>, where the <i>basic limit</i> within <i>sub-block gaps</i> shall be $\text{Min}(P_{\text{rated,c,cell}} - 10 \times \log_{10}(N_{\text{TXU,countedpercell}}) - 59 \text{ dB}, -25 \text{ dBm})/100 \text{ kHz}$.</p> <p>NOTE 2: For <i>multi-band TAB connectors</i> with <i>Inter RF Bandwidth gap</i> $< 2 \times \Delta f_{\text{OBUE}}$ MHz the <i>basic limit</i> within the <i>Inter RF Bandwidth gaps</i> is calculated as a cumulative sum of contributions from adjacent <i>sub-blocks</i> or <i>Base Station RF Bandwidth</i> on each side of the <i>Inter RF Bandwidth gap</i>.</p> <p>NOTE 3: The requirement is not applicable when $\Delta f_{\text{max}} < 10$ MHz.</p>			

Table 4.3.2.2.5-7: Medium Range BS operating band unwanted emissions limits for 3 MHz channel bandwidth, $P_{\text{rated,c,cell}} - 10 \times \log_{10}(N_{\text{TXU,countedpercell}}) \leq 31$ dBm (E-UTRA bands ≤ 3 GHz)

Frequency offset of measurement filter -3 dB point, Δf	Frequency offset of measurement filter centre frequency, f_{offset}	basic limit (notes 1 and 2)	Measurement bandwidth
$0 \text{ MHz} \leq \Delta f < 3 \text{ MHz}$	$0,05 \text{ MHz} \leq f_{\text{offset}} < 3,05 \text{ MHz}$	$-16,5 - \frac{10}{3} \times (f_{\text{offset}} - 0,05) \text{ dBm}$	100 kHz
$3 \text{ MHz} \leq \Delta f < 6 \text{ MHz}$	$3,05 \text{ MHz} \leq f_{\text{offset}} < 6,05 \text{ MHz}$	-26,5 dBm	100 kHz
$6 \text{ MHz} \leq \Delta f \leq \Delta f_{\text{max}}$	$6,05 \text{ MHz} \leq f_{\text{offset}} < f_{\text{offsetmax}}$	-28 dBm (note 3)	100 kHz

NOTE 1: For TAB connectors supporting *non-contiguous spectrum* operation within any *operating band* the *basic limit* within *sub-block gaps* is calculated as a cumulative sum of contributions from adjacent sub-blocks on each side of the *sub-block gap*. Exception is $\Delta f \geq 10$ MHz from both adjacent sub-blocks on each side of the *sub-block gap*, where the *basic limit* within *sub-block gaps* shall be -28 dBm/100 kHz.

NOTE 2: For *multi-band TAB connectors* with *Inter RF Bandwidth gap* $< 2 \times \Delta f_{\text{OBUE}}$ MHz the *basic limit* within the *Inter RF Bandwidth gaps* is calculated as a cumulative sum of contributions from adjacent *sub-blocks* or *Base Station RF Bandwidth* on each side of the *Inter RF Bandwidth gap*.

NOTE 3: The requirement is not applicable when $\Delta f_{\text{max}} < 10$ MHz.

Table 4.3.2.2.5-8: Medium Range BS operating band unwanted emissions limits for 3 MHz channel bandwidth, $P_{\text{rated,c,cell}} - 10 \times \log_{10}(N_{\text{TXU,countedpercell}}) \leq 31$ dBm (E-UTRA bands > 3 GHz)

Frequency offset of measurement filter -3 dB point, Δf	Frequency offset of measurement filter centre frequency, f_{offset}	basic limit (notes 1 and 2)	Measurement bandwidth
$0 \text{ MHz} \leq \Delta f < 3 \text{ MHz}$	$0,05 \text{ MHz} \leq f_{\text{offset}} < 3,05 \text{ MHz}$	$-16,2 - \frac{10}{3} \times (f_{\text{offset}} - 0,05) \text{ dBm}$	100 kHz
$3 \text{ MHz} \leq \Delta f < 6 \text{ MHz}$	$3,05 \text{ MHz} \leq f_{\text{offset}} < 6,05 \text{ MHz}$	-26,2 dBm	100 kHz
$6 \text{ MHz} \leq \Delta f \leq \Delta f_{\text{max}}$	$6,05 \text{ MHz} \leq f_{\text{offset}} < f_{\text{offsetmax}}$	-28 dBm (note 3)	100 kHz

NOTE 1: For TAB connectors supporting *non-contiguous spectrum* operation within any *operating band* the *basic limit* within *sub-block gaps* is calculated as a cumulative sum of contributions from adjacent sub-blocks on each side of the *sub-block gap*. Exception is $\Delta f \geq 10$ MHz from both adjacent sub-blocks on each side of the *sub-block gap*, where the *basic limit* within *sub-block gaps* shall be -28 dBm/100 kHz.

NOTE 2: For *multi-band TAB connectors* with *Inter RF Bandwidth gap* $< 2 \times \Delta f_{\text{OBUE}}$ MHz the *basic limit* within the *Inter RF Bandwidth gaps* is calculated as a cumulative sum of contributions from adjacent *sub-blocks* or *Base Station RF Bandwidth* on each side of the *Inter RF Bandwidth gap*.

NOTE 3: The requirement is not applicable when $\Delta f_{\text{max}} < 10$ MHz.

Table 4.3.2.2.5-9: Medium Range BS operating band unwanted emissions limits for 5 MHz, 10 MHz, 15 MHz and 20 MHz channel bandwidth, $31 \text{ dBm} < P_{\text{rated,c,cell}} - 10 \times \log_{10}(N_{\text{TXU,countedpercell}}) \leq 38$ dBm (E-UTRA bands ≤ 3 GHz)

Frequency offset of measurement filter -3 dB point, Δf	Frequency offset of measurement filter centre frequency, f_{offset}	basic limit (notes 1 and 2)	Measurement bandwidth
$0 \text{ MHz} \leq \Delta f < 5 \text{ MHz}$	$0,05 \text{ MHz} \leq f_{\text{offset}} < 5,05 \text{ MHz}$	$P_{\text{rated,c,cell}} - 10 \times \log_{10}(N_{\text{TXU,countedpercell}}) - 51,5 - \frac{7}{5} \times (f_{\text{offset}} - 0,05) \text{ dBm}$	100 kHz
$5 \text{ MHz} \leq \Delta f < \min(10 \text{ MHz}, \Delta f_{\text{max}})$	$5,05 \text{ MHz} \leq f_{\text{offset}} < \min(10,05 \text{ MHz}, f_{\text{offsetmax}})$	$P_{\text{rated,c,cell}} - 10 \times \log_{10}(N_{\text{TXU,countedpercell}}) - 58,5 \text{ dBm}$	100 kHz
$10 \text{ MHz} \leq \Delta f \leq \Delta f_{\text{max}}$	$10,05 \text{ MHz} \leq f_{\text{offset}} < f_{\text{offsetmax}}$	$\text{Min}(P_{\text{rated,c,cell}} - 10 \times \log_{10}(N_{\text{TXU,countedpercell}}) - 60, -25) \text{ dBm}$ (note 3)	100 kHz

NOTE 1: For TAB connectors supporting *non-contiguous spectrum* operation within any *operating band* the *basic limit* within *sub-block gaps* is calculated as a cumulative sum of contributions from adjacent sub-blocks on each side of the *sub-block gap*. Exception is $\Delta f \geq 10$ MHz from both adjacent sub-blocks on each side of the *sub-block gap*, where the *basic limit* within *sub-block gaps* shall be $\text{Min}(P_{\text{rated,c,cell}} - 10 \times \log_{10}(N_{\text{TXU,countedpercell}}) - 60 \text{ dB}, -25 \text{ dBm})/100 \text{ kHz}$.

NOTE 2: For *multi-band TAB connectors* with *Inter RF Bandwidth gap* $< 2 \times \Delta f_{\text{OBUE}}$ MHz the *basic limit* within the *Inter RF Bandwidth gaps* is calculated as a cumulative sum of contributions from adjacent *sub-blocks* or *Base Station RF Bandwidth* on each side of the *Inter RF Bandwidth gap*.

NOTE 3: The requirement is not applicable when $\Delta f_{\text{max}} < 10$ MHz.

Table 4.3.2.2.5-10: Medium Range BS operating band unwanted emissions limits for 5 MHz, 10 MHz, 15 MHz and 20 MHz channel bandwidth, $31 \text{ dBm} < P_{\text{rated,c,cell}} - 10 \times \log_{10}(N_{\text{TXU,countedpercell}}) \leq 38 \text{ dBm}$ (E-UTRA bands > 3 GHz)

Frequency offset of measurement filter -3 dB point, Δf	Frequency offset of measurement filter centre frequency, f_{offset}	basic limit (notes 1 and 2)	Measurement bandwidth
$0 \text{ MHz} \leq \Delta f < 5 \text{ MHz}$	$0,05 \text{ MHz} \leq f_{\text{offset}} < 5,05 \text{ MHz}$	$P_{\text{rated,c,cell}} - 10 \times \log_{10}(N_{\text{TXU,countedpercell}}) - 51,2 - \frac{7}{5} \times (f_{\text{offset}} - 0,05) \text{ dBm}$	100 kHz
$5 \text{ MHz} \leq \Delta f < \min(10 \text{ MHz}, \Delta f_{\text{max}})$	$5,05 \text{ MHz} \leq f_{\text{offset}} < \min(10,05 \text{ MHz}, f_{\text{offsetmax}})$	$P_{\text{rated,c,cell}} - 10 \times \log_{10}(N_{\text{TXU,countedpercell}}) - 58,2 \text{ dBm}$	100 kHz
$10 \text{ MHz} \leq \Delta f \leq \Delta f_{\text{max}}$	$10,05 \text{ MHz} \leq f_{\text{offset}} < f_{\text{offsetmax}}$	$\text{Min}(P_{\text{rated,c,cell}} - 10 \times \log_{10}(N_{\text{TXU,countedpercell}}) - 60, -25) \text{ dBm}$ (note 3)	100 kHz
<p>NOTE 1: For TAB connectors supporting <i>non-contiguous spectrum</i> operation within any <i>operating band</i> the <i>basic limit</i> within <i>sub-block gaps</i> is calculated as a cumulative sum of contributions from adjacent sub-blocks on each side of the <i>sub-block gap</i>. Exception is $\Delta f \geq 10 \text{ MHz}$ from both adjacent sub-blocks on each side of the <i>sub-block gap</i>, where the <i>basic limit</i> within <i>sub-block gaps</i> shall be $\text{Min}(P_{\text{rated,c,cell}} - 10 \times \log_{10}(N_{\text{TXU,countedpercell}}) - 60 \text{ dB}, -25 \text{ dBm})/100 \text{ kHz}$.</p> <p>NOTE 2: For <i>multi-band TAB connectors</i> with <i>Inter RF Bandwidth gap</i> $< 2 \times \Delta f_{\text{OBUE}}$ MHz the <i>basic limit</i> within the <i>Inter RF Bandwidth gaps</i> is calculated as a cumulative sum of contributions from adjacent <i>sub-blocks</i> or <i>Base Station RF Bandwidth</i> on each side of the <i>Inter RF Bandwidth gap</i>.</p> <p>NOTE 3: The requirement is not applicable when $\Delta f_{\text{max}} < 10 \text{ MHz}$.</p>			

Table 4.3.2.2.5-11: Medium Range BS operating band unwanted emissions limits for 5 MHz, 10 MHz, 15 MHz and 20 MHz channel bandwidth, $P_{\text{rated,c,cell}} - 10 \times \log_{10}(N_{\text{TXU,countedpercell}}) \leq 31 \text{ dBm}$ (E-UTRA bands $\leq 3 \text{ GHz}$)

Frequency offset of measurement filter -3 dB point, Δf	Frequency offset of measurement filter centre frequency, f_{offset}	basic limit (notes 1 and 2)	Measurement bandwidth
$0 \text{ MHz} \leq \Delta f < 5 \text{ MHz}$	$0,05 \text{ MHz} \leq f_{\text{offset}} < 5,05 \text{ MHz}$	$-20,5 - \frac{7}{5} \times (f_{\text{offset}} - 0,05) \text{ dBm}$	100 kHz
$5 \text{ MHz} \leq \Delta f < \min(10 \text{ MHz}, \Delta f_{\text{max}})$	$5,05 \text{ MHz} \leq f_{\text{offset}} < \min(10,05 \text{ MHz}, f_{\text{offsetmax}})$	-27,5 dBm	100 kHz
$10 \text{ MHz} \leq \Delta f \leq \Delta f_{\text{max}}$	$10,05 \text{ MHz} \leq f_{\text{offset}} < f_{\text{offsetmax}}$	-29 dBm (note 3)	100 kHz
<p>NOTE 1: For TAB connectors supporting <i>non-contiguous spectrum</i> operation within any <i>operating band</i> the <i>basic limit</i> within <i>sub-block gaps</i> is calculated as a cumulative sum of contributions from adjacent sub-blocks on each side of the <i>sub-block gap</i>. Exception is $\Delta f \geq 10 \text{ MHz}$ from both adjacent sub-blocks on each side of the <i>sub-block gap</i>, where the <i>basic limit</i> within <i>sub-block gaps</i> shall be -29 dBm/100 kHz.</p> <p>NOTE 2: For <i>multi-band TAB connectors</i> with <i>Inter RF Bandwidth gap</i> $< 2 \times \Delta f_{\text{OBUE}}$ MHz the <i>basic limit</i> within the <i>Inter RF Bandwidth gaps</i> is calculated as a cumulative sum of contributions from adjacent <i>sub-blocks</i> or <i>Base Station RF Bandwidth</i> on each side of the <i>Inter RF Bandwidth gap</i>.</p> <p>NOTE 3: The requirement is not applicable when $\Delta f_{\text{max}} < 10 \text{ MHz}$.</p>			

Table 4.3.2.2.5-12: Medium Range BS operating band unwanted emissions limits for 5 MHz, 10 MHz, 15 MHz and 20 MHz channel bandwidth, $P_{\text{rated,c,cell}} - 10 \times \log_{10}(N_{\text{TXU,countedpercell}}) \leq 31$ dBm (E-UTRA bands > 3 GHz)

Frequency offset of measurement filter -3 dB point, Δf	Frequency offset of measurement filter centre frequency, f_{offset}	basic limit (notes 1 and 2)	Measurement bandwidth
$0 \text{ MHz} \leq \Delta f < 5 \text{ MHz}$	$0,05 \text{ MHz} \leq f_{\text{offset}} < 5,05 \text{ MHz}$	$-20,2 - \frac{7}{5} \times (f_{\text{offset}} - 0,05) \text{ dBm}$	100 kHz
$5 \text{ MHz} \leq \Delta f < \min(10 \text{ MHz}, \Delta f_{\text{max}})$	$5,05 \text{ MHz} \leq f_{\text{offset}} < \min(10,05 \text{ MHz}, f_{\text{offsetmax}})$	-27,2 dBm	100 kHz
$10 \text{ MHz} \leq \Delta f \leq \Delta f_{\text{max}}$	$10,05 \text{ MHz} \leq f_{\text{offset}} < f_{\text{offsetmax}}$	-29 dBm (note 3)	100 kHz
NOTE 1: For TAB connectors supporting non-contiguous spectrum operation within any operating band the basic limit within sub-block gaps is calculated as a cumulative sum of contributions from adjacent sub-blocks on each side of the sub-block gap. Exception is $\Delta f \geq 10$ MHz from both adjacent sub-blocks on each side of the sub-block gap, where the basic limit within sub-block gaps shall be -29 dBm/100 kHz.			
NOTE 2: For multi-band TAB connectors with Inter RF Bandwidth gap < $2 \times \Delta f_{\text{OBUE}}$ MHz the basic limit within the Inter RF Bandwidth gaps is calculated as a cumulative sum of contributions from adjacent sub-blocks or Base Station RF Bandwidth on each side of the Inter RF Bandwidth gap.			
NOTE 3: The requirement is not applicable when $\Delta f_{\text{max}} < 10$ MHz.			

4.3.2.2.6

Basic limits for Local Area BS

Table 4.3.2.2.6-1: Local Area BS operating band unwanted emissions limits for 1,4 MHz channel bandwidth (E-UTRA bands ≤ 3 GHz)

Frequency offset of measurement filter -3 dB point, Δf	Frequency offset of measurement filter centre frequency, f_{offset}	basic limit (notes 1 and 2)	Measurement bandwidth
$0 \text{ MHz} \leq \Delta f < 1,4 \text{ MHz}$	$0,05 \text{ MHz} \leq f_{\text{offset}} < 1,45 \text{ MHz}$	$-19,5 - \frac{10}{1,4} \times (f_{\text{offset}} - 0,05) \text{ dBm}$	100 kHz
$1,4 \text{ MHz} \leq \Delta f < 2,8 \text{ MHz}$	$1,45 \text{ MHz} \leq f_{\text{offset}} < 2,85 \text{ MHz}$	-29,5 dBm	100 kHz
$2,8 \text{ MHz} \leq \Delta f \leq \Delta f_{\text{max}}$	$2,85 \text{ MHz} \leq f_{\text{offset}} < f_{\text{offsetmax}}$	-31 dBm (note 3)	100 kHz
NOTE 1: For TAB connectors supporting non-contiguous spectrum operation within any operating band the basic limit within sub-block gaps is calculated as a cumulative sum of contributions from adjacent sub-blocks on each side of the sub-block gap. Exception is $\Delta f \geq 10$ MHz from both adjacent sub-blocks on each side of the sub-block gap, where the basic limit within sub-block gaps shall be -31 dBm/100 kHz.			
NOTE 2: For multi-band TAB connectors with Inter RF Bandwidth gap < $2 \times \Delta f_{\text{OBUE}}$ MHz the basic limit within the Inter RF Bandwidth gaps is calculated as a cumulative sum of contributions from adjacent sub-blocks or Base Station RF Bandwidth on each side of the Inter RF Bandwidth gap.			
NOTE 3: The requirement is not applicable when $\Delta f_{\text{max}} < 10$ MHz.			

Table 4.3.2.2.6-1a: Local Area BS operating band unwanted emissions limits for 1,4 MHz channel bandwidth (E-UTRA bands > 3 GHz)

Frequency offset of measurement filter -3 dB point, Δf	Frequency offset of measurement filter centre frequency, f_{offset}	basic limit (notes 1 and 2)	Measurement bandwidth
$0 \text{ MHz} \leq \Delta f < 1,4 \text{ MHz}$	$0,05 \text{ MHz} \leq f_{\text{offset}} < 1,45 \text{ MHz}$	$-19,2 - \frac{10}{1,4} \times (f_{\text{offset}} - 0,05) \text{ dBm}$	100 kHz
$1,4 \text{ MHz} \leq \Delta f < 2,8 \text{ MHz}$	$1,45 \text{ MHz} \leq f_{\text{offset}} < 2,85 \text{ MHz}$	-29,2 dBm	100 kHz
$2,8 \text{ MHz} \leq \Delta f \leq \Delta f_{\text{max}}$	$2,85 \text{ MHz} \leq f_{\text{offset}} < f_{\text{offsetmax}}$	-31 dBm (note 3)	100 kHz
NOTE 1: For TAB connectors supporting non-contiguous spectrum operation within any operating band the basic limit within sub-block gaps is calculated as a cumulative sum of contributions from adjacent sub-blocks on each side of the sub-block gap. Exception is $\Delta f \geq 10$ MHz from both adjacent sub-blocks on each side of the sub-block gap, where the basic limit within sub-block gaps shall be -31 dBm/100 kHz.			
NOTE 2: For multi-band TAB connectors with Inter RF Bandwidth gap < $2 \times \Delta f_{\text{OBUE}}$ MHz the basic limit within the Inter RF Bandwidth gaps is calculated as a cumulative sum of contributions from adjacent sub-blocks or Base Station RF Bandwidth on each side of the Inter RF Bandwidth gap.			
NOTE 3: The requirement is not applicable when $\Delta f_{\text{max}} < 10$ MHz.			

Table 4.3.2.2.2.6-2: Local Area BS operating band unwanted emissions limits for 3 MHz channel bandwidth (E-UTRA bands ≤ 3 GHz)

Frequency offset of measurement filter -3 dB point, Δf	Frequency offset of measurement filter centre frequency, f_{offset}	<i>basic limit</i> (notes 1 and 2)	<i>Measurement bandwidth</i>
$0 \text{ MHz} \leq \Delta f < 3 \text{ MHz}$	$0,05 \text{ MHz} \leq f_{\text{offset}} < 3,05 \text{ MHz}$	$-23,5 - \frac{10}{3} \times (f_{\text{offset}} - 0,05) \text{ dBm}$	100 kHz
$3 \text{ MHz} \leq \Delta f < 6 \text{ MHz}$	$3,05 \text{ MHz} \leq f_{\text{offset}} < 6,05 \text{ MHz}$	-33,5 dBm	100 kHz
$6 \text{ MHz} \leq \Delta f \leq \Delta f_{\text{max}}$	$6,05 \text{ MHz} \leq f_{\text{offset}} < f_{\text{offset}_{\text{max}}}$	-35 dBm (note 3)	100 kHz

NOTE 1: For *TAB connectors* supporting *non-contiguous spectrum* operation within any *operating band* the *basic limit* within *sub-block gaps* is calculated as a cumulative sum of contributions from adjacent sub-blocks on each side of the *sub-block gap*. Exception is $\Delta f \geq 10 \text{ MHz}$ from both adjacent sub-blocks on each side of the *sub-block gap*, where the *basic limit* within *sub-block gaps* shall be -35 dBm/100 kHz.

NOTE 2: For *multi-band TAB connectors* with *Inter RF Bandwidth gap* $< 2 \times \Delta f_{\text{OBUE}}$ MHz the *basic limit* within the *Inter RF Bandwidth gaps* is calculated as a cumulative sum of contributions from adjacent *sub-blocks* or *Base Station RF Bandwidth* on each side of the *Inter RF Bandwidth gap*.

NOTE 3: The requirement is not applicable when $\Delta f_{\text{max}} < 10 \text{ MHz}$.

Table 4.3.2.2.2.6-2a: Local Area BS operating band unwanted emissions limits for 3 MHz channel bandwidth (E-UTRA bands > 3 GHz)

Frequency offset of measurement filter -3 dB point, Δf	Frequency offset of measurement filter centre frequency, f_{offset}	<i>basic limit</i> (notes 1 and 2)	<i>Measurement bandwidth</i>
$0 \text{ MHz} \leq \Delta f < 3 \text{ MHz}$	$0,05 \text{ MHz} \leq f_{\text{offset}} < 3,05 \text{ MHz}$	$-23,2 - \frac{10}{3} \times (f_{\text{offset}} - 0,05) \text{ dBm}$	100 kHz
$3 \text{ MHz} \leq \Delta f < 6 \text{ MHz}$	$3,05 \text{ MHz} \leq f_{\text{offset}} < 6,05 \text{ MHz}$	-33,2 dBm	100 kHz
$6 \text{ MHz} \leq \Delta f \leq \Delta f_{\text{max}}$	$6,05 \text{ MHz} \leq f_{\text{offset}} < f_{\text{offset}_{\text{max}}}$	-35 dBm (note 3)	100 kHz

NOTE 1: For *TAB connectors* supporting *non-contiguous spectrum* operation within any *operating band* the *basic limit* within *sub-block gaps* is calculated as a cumulative sum of contributions from adjacent sub-blocks on each side of the *sub-block gap*. Exception is $\Delta f \geq 10 \text{ MHz}$ from both adjacent sub-blocks on each side of the *sub-block gap*, where the *basic limit* within *sub-block gaps* shall be -35 dBm/100 kHz.

NOTE 2: For *multi-band TAB connectors* with *Inter RF Bandwidth gap* $< 2 \times \Delta f_{\text{OBUE}}$ MHz the *basic limit* within the *Inter RF Bandwidth gaps* is calculated as a cumulative sum of contributions from adjacent *sub-blocks* or *Base Station RF Bandwidth* on each side of the *Inter RF Bandwidth gap*.

NOTE 3: The requirement is not applicable when $\Delta f_{\text{max}} < 10 \text{ MHz}$.

Table 4.3.2.2.2.6-3: Local Area BS operating band unwanted emissions limits for 5 MHz, 10 MHz, 15 MHz and 20 MHz channel bandwidth (E-UTRA bands ≤ 3 GHz)

Frequency offset of measurement filter -3 dB point, Δf	Frequency offset of measurement filter centre frequency, f_{offset}	<i>basic limit</i> (notes 1 and 2)	<i>Measurement bandwidth</i>
$0 \text{ MHz} \leq \Delta f < 5 \text{ MHz}$	$0,05 \text{ MHz} \leq f_{\text{offset}} < 5,05 \text{ MHz}$	$-28,5 - \frac{7}{5} \times (f_{\text{offset}} - 0,05) \text{ dBm}$	100 kHz
$5 \text{ MHz} \leq \Delta f < \min(10 \text{ MHz}, \Delta f_{\text{max}})$	$5,05 \text{ MHz} \leq f_{\text{offset}} < \min(10,05 \text{ MHz}, f_{\text{offset}_{\text{max}}})$	-35,5 dBm	100 kHz
$10 \text{ MHz} \leq \Delta f \leq \Delta f_{\text{max}}$	$10,05 \text{ MHz} \leq f_{\text{offset}} < f_{\text{offset}_{\text{max}}}$	-37 dBm (note 3)	100 kHz

NOTE 1: For *TAB connectors* supporting *non-contiguous spectrum* operation within any *operating band* the *basic limit* within *sub-block gaps* is calculated as a cumulative sum of contributions from adjacent sub-blocks on each side of the *sub-block gap*. Exception is $\Delta f \geq 10 \text{ MHz}$ from both adjacent sub-blocks on each side of the *sub-block gap*, where the *basic limit* within *sub-block gaps* shall be -37 dBm/100 kHz.

NOTE 2: For *multi-band TAB connectors* with *Inter RF Bandwidth gap* $< 2 \times \Delta f_{\text{OBUE}}$ MHz the *basic limit* within the *Inter RF Bandwidth gaps* is calculated as a cumulative sum of contributions from adjacent *sub-blocks* or *Base Station RF Bandwidth* on each side of the *Inter RF Bandwidth gap*.

NOTE 3: The requirement is not applicable when $\Delta f_{\text{max}} < 10 \text{ MHz}$.

Table 4.3.2.2.2.6-3a: Local Area BS operating band unwanted emissions limits for 5 MHz, 10 MHz, 15 MHz and 20 MHz channel bandwidth (E-UTRA bands > 3 GHz)

Frequency offset of measurement filter -3 dB point, Δf	Frequency offset of measurement filter centre frequency, f_{offset}	basic limit (notes 1 and 2)	Measurement bandwidth
$0 \text{ MHz} \leq \Delta f < 5 \text{ MHz}$	$0,05 \text{ MHz} \leq f_{\text{offset}} < 5,05 \text{ MHz}$	$-28,2 - \frac{7}{5} \times (f_{\text{offset}} - 0,05) \text{ dB}$	100 kHz
$5 \text{ MHz} \leq \Delta f < \min(10 \text{ MHz}, \Delta f_{\text{max}})$	$5,05 \text{ MHz} \leq f_{\text{offset}} < \min(10,05 \text{ MHz}, f_{\text{offset}_{\text{max}}})$	-35,2 dBm	100 kHz
$10 \text{ MHz} \leq \Delta f \leq \Delta f_{\text{max}}$	$10,05 \text{ MHz} \leq f_{\text{offset}} < f_{\text{offset}_{\text{max}}}$	-37 dBm (note 3)	100 kHz

NOTE 1: For TAB connectors supporting non-contiguous spectrum operation within any operating band the basic limit within sub-block gaps is calculated as a cumulative sum of contributions from adjacent sub-blocks on each side of the sub-block gap. Exception is $\Delta f \geq 10 \text{ MHz}$ from both adjacent sub-blocks on each side of the sub-block gap, where the basic limit within sub-block gaps shall be -37 dBm/100 kHz.

NOTE 2: For BS a multi-band TAB connector with Inter RF Bandwidth gap < $2 \times \Delta f_{\text{OBUe}}$ MHz the basic limit within the Inter RF Bandwidth gaps is calculated as a cumulative sum of contributions from adjacent sub-blocks or Base Station RF Bandwidth on each side of the Inter RF Bandwidth gap.

NOTE 3: The requirement is not applicable when $\Delta f_{\text{max}} < 10 \text{ MHz}$.

4.3.2.2.2.7 Additional Requirements

The limits in table 4.3.2.2.2.7-1 shall apply to BS operating in bands 77 and 78, for co-existence with FSS/FS. For each TAB connector TX min cell group, the power summation of the emissions at the TAB connectors of the TAB connector TX min cell group shall not exceed the limit in table 4.3.2.2.2.7-1.

Table 4.3.2.2.2.7-1: Additional operating band unwanted emissions limits for BS operating in bands 77 and 78

Frequency range	Limit	Measurement bandwidth
3 800 MHz to 3 805 MHz	$\text{Min}(P_{\text{rated,t,cell}} - 40, 16) \text{ dBm}$	5 MHz
3 805 MHz to 3 810 MHz	$\text{Min}(P_{\text{rated,t,cell}} - 43, 12) \text{ dBm}$	5 MHz
3 810 MHz to 3 840 MHz	$\text{Min}(P_{\text{rated,t,cell}} - 43, 1) \text{ dBm}$	5 MHz
Above 3 840 MHz	-14 dBm	5 MHz

NOTE: $P_{\text{rated,t,cell}}$ is the total rated output power as a sum over all TAB connectors of the TAB connector TX min cell group.

The limit in table 4.3.2.2.2.7-2 shall apply to BS operating in band 40, for protection of systems above 2 400 MHz. For each TAB connector TX min cell group, the power summation of the emissions at the TAB connectors of the TAB connector TX min cell group shall not exceed the limit in table 4.3.2.2.2.7-2.

Table 4.3.2.2.2.7-2: Additional operating band unwanted emission limits for BS operating in band 40

Frequency range	Total rated output power per cell $P_{\text{rated,t,cell}}$	Limit	Measurement bandwidth
Above 2 403 MHz	$P_{\text{rated,t,cell}} > 47 \text{ dBm}$	-13 dBm	5 MHz
	$33 \text{ dBm} < P_{\text{rated,t,cell}} \leq 47 \text{ dBm}$	$P_{\text{rated,t,TRP}} - 60 \text{ dBm}$	5 MHz
	$P_{\text{rated,t,cell}} \leq 33 \text{ dBm}$	-27 dBm	5 MHz

NOTE: $P_{\text{rated,t,cell}}$ is the total rated output power as a sum over all TAB connectors of the TAB connector TX min cell group.

NOTE 1: For a BS operating in band 20, additional limits for protection of DTT are described in clause 6.6.5.5.7 of ETSI TS 137 145-1 [2]. This statement is provided for information and does not have any impact on the conformance requirements or essential radio test suites in the present document.

NOTE 2: For a BS operating in band 32, additional limits are described in clause 6.6.5.5.7 of ETSI TS 137 145-1 [2]. This statement is provided for information and does not have any impact on the conformance requirements or essential radio test suites in the present document.

4.3.2.3 Conformance

The conformance tests for this requirement shall be as defined in clause 5.3.2 of the present document.

4.3.3 Spectrum Emission Mask (SEM)

4.3.3.1 Definition and applicability

The spectrum emission mask requirements for a UTRA single RAT AAS BS are for each *TAB connector TX min cell group* the power summation of emissions at the *TAB connectors* of the *TAB connector TX min cell group* shall not exceed a limit specified as the *basic limit* + $10\log_{10}(N_{\text{TXU, counted per cell}})$.

4.3.3.2 Limits

The *basic limit* is specified in tables 4.3.3.2-1 to 4.3.3.2-8, where:

- Δf is the separation between the carrier frequency and the nominal -3 dB point of the measuring filter closest to the carrier frequency.
- f_{offset} is the separation between the carrier frequency and the centre of the measurement filter.
- $f_{\text{offset}_{\text{max}}}$ is either 12,5 MHz or the offset to the UMTS Tx band edge as defined in table 1-1, whichever is the greater.
- Δf_{max} is equal to $f_{\text{offset}_{\text{max}}}$ minus half of the bandwidth of the measuring filter.

Inside any *Inter RF Bandwidth gaps* with $W_{\text{gap}} < 2 \times \Delta f_{\text{OBUE}}$ for *multi-band TAB connectors*, emissions shall not exceed the cumulative sum of the *basic limits* specified at the *Base Station RF Bandwidth edges* on each side of the *Inter RF Bandwidth gap*. The *basic limit* for *Base Station RF Bandwidth edge* is specified in tables 4.3.3.2-1 to 4.3.3.2-10 below, where in this case:

- Δf is equal to 2,5 MHz plus the separation between the *Base Station RF Bandwidth edge* frequency and the nominal -3 dB point of the measuring filter closest to the *Base Station RF Bandwidth edge*.
- f_{offset} is equal to 2,5 MHz plus the separation between the *Base Station RF Bandwidth edge* frequency and the centre of the measuring filter.
- $f_{\text{offset}_{\text{max}}}$ is either 12,5 MHz or the offset to the UMTS Tx band edge as defined in table 1-1, whichever is the greater.
- Δf_{max} is equal to $f_{\text{offset}_{\text{max}}}$ minus half of the bandwidth of the measuring filter.

Measurement filter is defined as in Recommendation ITU-R SM.329-12 [i.4], section 4.1.

For *multi-band TAB connectors*, the *operating band unwanted emission basic limits* apply also in a supported *operating band* without any carrier transmitted, in the case where there are carrier(s) transmitted in another supported *operating band*. In this case, no cumulative limit is applied in the *inter-band gap* between a supported *downlink operating band* with carrier(s) transmitted and a supported *downlink operating band* without any carrier transmitted and:

- In case the *inter-band gap* between a downlink band with carrier(s) transmitted and a downlink band without any carrier transmitted is less than $2 \times \Delta f_{\text{OBUE}}$, $f_{\text{offset}_{\text{max}}}$ shall be the offset to the frequency Δf_{OBUE} outside the outermost edges of the two *downlink operating bands* and the *operating band unwanted emission* limit of the band where there are carriers transmitted, as defined in the tables of the present clause, shall apply across both downlink bands.
- In other cases, the *operating band unwanted emission* limit of the band where there are carriers transmitted, as defined in the tables of the present clause for the largest frequency offset (Δf_{max}), shall apply from Δf_{OBUE} below the lowest frequency, up to Δf_{OBUE} above the highest frequency of the *downlink operating band* without any carrier transmitted.

Inside any *sub-block gap* for *TAB connectors* operating in *non-contiguous spectrum*, emissions shall not exceed the cumulative sum of the *basic limits* specified for the adjacent sub-blocks on each side of the *sub-block gap*. The *basic limit* for each sub-block is specified in tables 4.3.3.2-1 to 4.3.3.2-8 below, where in this case:

- Δf is equal to 2,5 MHz plus the separation between the sub-block edge frequency and the nominal -3 dB point of the measuring filter closest to the sub-block edge.
- f_{offset} is equal to 2,5 MHz plus the separation between the sub-block edge frequency and the centre of the measuring filter.
- $f_{\text{offset}_{\text{max}}}$ is equal to the *sub-block gap* bandwidth minus half of the bandwidth of the measuring filter plus 2,5 MHz.
- Δf_{max} is equal to $f_{\text{offset}_{\text{max}}}$ minus half of the bandwidth of the measuring filter.

In the following clauses the numerical values for f_{offset} , Δf and Δf_{max} shall be expressed in MHz.

Table 4.3.3.2-1: Spectrum emission mask, $P_{\text{rated,c,cell}} - 10 \times \log_{10}(N_{\text{TXU,countedpercell}}) \geq 43$ dBm for UTRA bands ≤ 3 GHz

Frequency offset of measurement filter -3 dB point, Δf	Frequency offset of measurement filter centre frequency, f_{offset}	<i>basic limit</i> (notes 1 and 2)	<i>Measurement bandwidth</i>
$2,5 \text{ MHz} \leq \Delta f < 2,7 \text{ MHz}$	$2,515 \text{ MHz} \leq f_{\text{offset}} < 2,715 \text{ MHz}$	-12,5 dBm	30 kHz
$2,7 \text{ MHz} \leq \Delta f < 3,5 \text{ MHz}$	$2,715 \text{ MHz} \leq f_{\text{offset}} < 3,515 \text{ MHz}$	$-12,5 - 15 \times (f_{\text{offset}} - 2,715) \text{ dBm}$	30 kHz
(note 3)	$3,515 \text{ MHz} \leq f_{\text{offset}} < 4,0 \text{ MHz}$	-24,5 dBm	30 kHz
$3,5 \text{ MHz} \leq \Delta f < 7,5 \text{ MHz}$	$4,0 \text{ MHz} \leq f_{\text{offset}} < 8,0 \text{ MHz}$	-11,5 dBm	1 MHz
$7,5 \text{ MHz} \leq \Delta f \leq \Delta f_{\text{max}}$	$8,0 \text{ MHz} \leq f_{\text{offset}} < f_{\text{offset}_{\text{max}}}$	-11,5 dBm	1 MHz
<p>NOTE 1: For <i>TAB connectors</i> supporting <i>non-contiguous spectrum</i> operation the <i>basic limit</i> within <i>sub-block gaps</i> within any <i>operating band</i> is calculated as a cumulative sum of contributions from adjacent sub-blocks on each side of the <i>sub-block gap</i>, where the contribution from the far-end <i>sub-block</i> shall be scaled according to the <i>measurement bandwidth</i> of the near-end <i>sub-block</i>. Exception is $\Delta f \geq 12,5$ MHz from both adjacent sub-blocks on each side of the <i>sub-block gap</i>, where <i>basic limit</i> within <i>sub-block gaps</i> shall be -11,5 dBm/MHz.</p> <p>NOTE 2: For <i>multi-band TAB connectors</i> with <i>Inter RF Bandwidth gap</i> $< 2 \times \Delta f_{\text{OBUE}}$ MHz the limit within the <i>Inter RF Bandwidth gaps</i> is calculated as a cumulative sum of contributions from adjacent <i>sub-blocks</i> or <i>Base Station RF Bandwidth</i> on each side of the <i>Inter RF Bandwidth gap</i>, where the contribution from the far-end <i>sub-block</i> or <i>Base Station RF Bandwidth</i> shall be scaled according to the <i>measurement bandwidth</i> of the near-end <i>sub-block</i> or <i>Base Station RF Bandwidth</i>.</p> <p>NOTE 3: This frequency range ensures that the range of values of f_{offset} is continuous.</p>			

**Table 4.3.3.2-2: Spectrum emission mask, $P_{\text{rated,c,cell}} - 10 \times \log_{10}(N_{\text{TXU,countedpercell}}) \geq 43$ dBm
UTRA bands > 3 GHz**

Frequency offset of measurement filter -3 dB point, Δf	Frequency offset of measurement filter centre frequency, f_{offset}	<i>basic limit</i> (notes 1 and 2)	<i>Measurement bandwidth</i>
$2,5 \text{ MHz} \leq \Delta f < 2,7 \text{ MHz}$	$2,515 \text{ MHz} \leq f_{\text{offset}} < 2,715 \text{ MHz}$	-12,2 dBm	30 kHz
$2,7 \text{ MHz} \leq \Delta f < 3,5 \text{ MHz}$	$2,715 \text{ MHz} \leq f_{\text{offset}} < 3,515 \text{ MHz}$	$-12,2 - 15 \times (f_{\text{offset}} - 2,715) \text{ dBm}$	30 kHz
(note 3)	$3,515 \text{ MHz} \leq f_{\text{offset}} < 4,0 \text{ MHz}$	-24,2 dBm	30 kHz
$3,5 \text{ MHz} \leq \Delta f < 7,5 \text{ MHz}$	$4,0 \text{ MHz} \leq f_{\text{offset}} < 8,0 \text{ MHz}$	-11,2 dBm	1 MHz
$7,5 \text{ MHz} \leq \Delta f \leq \Delta f_{\text{max}}$	$8,0 \text{ MHz} \leq f_{\text{offset}} < f_{\text{offset}_{\text{max}}}$	-11,2 dBm	1 MHz

NOTE 1: For *TAB connectors* supporting *non-contiguous spectrum* operation the *basic limit* within *sub-block gaps* within any *operating band* is calculated as a cumulative sum of contributions from adjacent sub-blocks on each side of the *sub-block gap*, where the contribution from the far-end *sub-block* shall be scaled according to the *measurement bandwidth* of the near-end *sub-block*. Exception is $\Delta f \geq 12,5$ MHz from both adjacent sub-blocks on each side of the *sub-block gap*, where the *basic limit* within *sub-block gaps* shall be -11,2 dBm/MHz.

NOTE 2: For *multi-band TAB connectors* with *Inter RF Bandwidth gap* $< 2 \times \Delta f_{\text{OBUE}}$ MHz the limit within the *Inter RF Bandwidth gaps* is calculated as a cumulative sum of contributions from adjacent *sub-blocks* or *Base Station RF Bandwidth* on each side of the *Inter RF Bandwidth gap*, where the contribution from the far-end *sub-block* or *Base Station RF Bandwidth* shall be scaled according to the *measurement bandwidth* of the near-end *sub-block* or *Base Station RF Bandwidth*.

NOTE 3: This frequency range ensures that the range of values of f_{offset} is continuous.

**Table 4.3.3.2-3: Spectrum emission mask, $39 \text{ dBm} \leq P_{\text{rated,c,cell}} - 10 \times \log_{10}(N_{\text{TXU,countedpercell}}) < 43$ dBm
for UTRA bands ≤ 3 GHz**

Frequency offset of measurement filter -3 dB point, Δf	Frequency offset of measurement filter centre frequency, f_{offset}	<i>basic limit</i> (notes 1 and 2)	<i>Measurement bandwidth</i>
$2,5 \text{ MHz} \leq \Delta f < 2,7 \text{ MHz}$	$2,515 \text{ MHz} \leq f_{\text{offset}} < 2,715 \text{ MHz}$	-12,5 dBm	30 kHz
$2,7 \text{ MHz} \leq \Delta f < 3,5 \text{ MHz}$	$2,715 \text{ MHz} \leq f_{\text{offset}} < 3,515 \text{ MHz}$	$-12,5 - 15 \times (f_{\text{offset}} - 2,715) \text{ dBm}$	30 kHz
(note 3)	$3,515 \text{ MHz} \leq f_{\text{offset}} < 4,0 \text{ MHz}$	-24,5 dBm	30 kHz
$3,5 \text{ MHz} \leq \Delta f < 7,5 \text{ MHz}$	$4,0 \text{ MHz} \leq f_{\text{offset}} < 8,0 \text{ MHz}$	-11,5 dBm	1 MHz
$7,5 \text{ MHz} \leq \Delta f \leq \Delta f_{\text{max}}$	$8,0 \text{ MHz} \leq f_{\text{offset}} < f_{\text{offset}_{\text{max}}}$	$P_{\text{rated,c,cell}} - 10 \times \log_{10}(N_{\text{TXU,countedpercell}}) - 54,5 \text{ dBm}$	1 MHz

NOTE 1: For *TAB connectors* supporting *non-contiguous spectrum* operation the *basic limit* within *sub-block gaps* within any *operating band* is calculated as a cumulative sum of contributions from adjacent sub-blocks on each side of the *sub-block gap*, where the contribution from the far-end *sub-block* shall be scaled according to the *measurement bandwidth* of the near-end *sub-block*. Exception is $\Delta f \geq 12,5$ MHz from both adjacent sub-blocks on each side of the *sub-block gap*, where *basic limits* within *sub-block gaps* shall be $P_{\text{rated,c,cell}} - 10 \times \log_{10}(N_{\text{TXU,countedpercell}}) - 54,5$ dBm/MHz.

NOTE 2: For *multi-band TAB connectors* with *Inter RF Bandwidth gap* $< 2 \times \Delta f_{\text{OBUE}}$ MHz the limit within the *Inter RF Bandwidth gaps* is calculated as a cumulative sum of contributions from adjacent *sub-blocks* or *Base Station RF Bandwidth* on each side of the *Inter RF Bandwidth gap*, where the contribution from the far-end *sub-block* or *Base Station RF Bandwidth* shall be scaled according to the *measurement bandwidth* of the near-end *sub-block* or *Base Station RF Bandwidth*.

NOTE 3: This frequency range ensures that the range of values of f_{offset} is continuous.

Table 4.3.3.2-4: Spectrum emission mask, $39 \text{ dBm} \leq P_{\text{rated,c,cell}} - 10 \times \log_{10}(N_{\text{TXU,countedpercell}}) < 43 \text{ dBm}$ for UTRA bands $> 3 \text{ GHz}$

Frequency offset of measurement filter -3 dB point, Δf	Frequency offset of measurement filter centre frequency, f_{offset}	<i>basic limit</i> (notes 1 and 2)	<i>Measurement bandwidth</i>
$2,5 \text{ MHz} \leq \Delta f < 2,7 \text{ MHz}$	$2,515 \text{ MHz} \leq f_{\text{offset}} < 2,715 \text{ MHz}$	-12,2 dBm	30 kHz
$2,7 \text{ MHz} \leq \Delta f < 3,5 \text{ MHz}$	$2,715 \text{ MHz} \leq f_{\text{offset}} < 3,515 \text{ MHz}$	$-12,2 - 15 \times (f_{\text{offset}} - 2,715) \text{ dBm}$	30 kHz
(note 3)	$3,515 \text{ MHz} \leq f_{\text{offset}} < 4,0 \text{ MHz}$	-24,2 dBm	30 kHz
$3,5 \text{ MHz} \leq \Delta f < 7,5 \text{ MHz}$	$4,0 \text{ MHz} \leq f_{\text{offset}} < 8,0 \text{ MHz}$	-11,2 dBm	1 MHz
$7,5 \text{ MHz} \leq \Delta f \leq \Delta f_{\text{max}}$	$8,0 \text{ MHz} \leq f_{\text{offset}} < f_{\text{offset}_{\text{max}}}$	$P_{\text{rated,c,cell}} - 10 \times \log_{10}(N_{\text{TXU,countedpercell}}) - 54,2 \text{ dBm}$	1 MHz

NOTE 1: For *TAB connectors* supporting *non-contiguous spectrum* operation the *basic limit* within *sub-block gaps* within any *operating band* is calculated as a cumulative sum of contributions from adjacent sub-blocks on each side of the *sub-block gap*, where the contribution from the far-end *sub-block* shall be scaled according to the *measurement bandwidth* of the near-end *sub-block*. Exception is $\Delta f \geq 12,5 \text{ MHz}$ from both adjacent sub-blocks on each side of the *sub-block gap*, where *basic limit* $P_{\text{rated,c,cell}} - 10 \times \log_{10}(N_{\text{TXU,countedpercell}}) - 54,2 \text{ dBm/MHz}$.

NOTE 2: For *multi-band TAB connectors* with *Inter RF Bandwidth gap* $< 2 \times \Delta f_{\text{OBUE}}$ MHz the limit within the *Inter RF Bandwidth gaps* is calculated as a cumulative sum of contributions from adjacent *sub-blocks* or *Base Station RF Bandwidth* on each side of the *Inter RF Bandwidth gap*, where the contribution from the far-end *sub-block* or *Base Station RF Bandwidth* shall be scaled according to the *measurement bandwidth* of the near-end *sub-block* or *Base Station RF Bandwidth*.

NOTE 3: This frequency range ensures that the range of values of f_{offset} is continuous.

Table 4.3.3.2-5: Spectrum emission mask, $31 \text{ dBm} \leq P_{\text{rated,c,cell}} - 10 \times \log_{10}(N_{\text{TXU,countedpercell}}) < 39 \text{ dBm}$ for UTRA bands $\leq 3 \text{ GHz}$

Frequency offset of measurement filter -3 dB point, Δf	Frequency offset of measurement filter centre frequency, f_{offset}	<i>basic limit</i> (notes 1 and 2)	<i>Measurement bandwidth</i>
$2,5 \text{ MHz} \leq \Delta f < 2,7 \text{ MHz}$	$2,515 \text{ MHz} \leq f_{\text{offset}} < 2,715 \text{ MHz}$	$P_{\text{rated,c,cell}} - 10 \times \log_{10}(N_{\text{TXU,countedpercell}}) - 51,5 \text{ dB}$	30 kHz
$2,7 \text{ MHz} \leq \Delta f < 3,5 \text{ MHz}$	$2,715 \text{ MHz} \leq f_{\text{offset}} < 3,515 \text{ MHz}$	$P_{\text{rated,c,cell}} - 10 \times \log_{10}(N_{\text{TXU,countedpercell}}) - 51,5 - 15 \times (f_{\text{offset}} - 2,715) \text{ dBm}$	30 kHz
(note 3)	$3,515 \text{ MHz} \leq f_{\text{offset}} < 4,0 \text{ MHz}$	$P_{\text{rated,c,cell}} - 10 \times \log_{10}(N_{\text{TXU,countedpercell}}) - 63,5 \text{ dBm}$	30 kHz
$3,5 \text{ MHz} \leq \Delta f < 7,5 \text{ MHz}$	$4,0 \text{ MHz} \leq f_{\text{offset}} < 8,0 \text{ MHz}$	$P_{\text{rated,c,cell}} - 10 \times \log_{10}(N_{\text{TXU,countedpercell}}) - 50,5 \text{ dBm}$	1 MHz
$7,5 \text{ MHz} \leq \Delta f \leq \Delta f_{\text{max}}$	$8,0 \text{ MHz} \leq f_{\text{offset}} < f_{\text{offset}_{\text{max}}}$	$P_{\text{rated,c,cell}} - 10 \times \log_{10}(N_{\text{TXU,countedpercell}}) - 54,5 \text{ dBm}$	1 MHz

NOTE 1: For *TAB connectors* supporting *non-contiguous spectrum* operation the *basic limit* within *sub-block gaps* within any *operating band* is calculated as a cumulative sum of contributions from adjacent sub-blocks on each side of the *sub-block gap*, where the contribution from the far-end *sub-block* shall be scaled according to the *measurement bandwidth* of the near-end *sub-block*. Exception is $\Delta f \geq 12,5 \text{ MHz}$ from both adjacent sub-blocks on each side of the *sub-block gap*, where *basic limit* $P_{\text{rated,c,cell}} - 10 \times \log_{10}(N_{\text{TXU,countedpercell}}) - 54,5 \text{ dBm/MHz}$.

NOTE 2: For *multi-band TAB connectors* with *Inter RF Bandwidth gap* $< 2 \times \Delta f_{\text{OBUE}}$ MHz the limit within the *Inter RF Bandwidth gaps* is calculated as a cumulative sum of contributions from adjacent *sub-blocks* or *Base Station RF Bandwidth* on each side of the *Inter RF Bandwidth gap*, where the contribution from the far-end *sub-block* or *Base Station RF Bandwidth* shall be scaled according to the *measurement bandwidth* of the near-end *sub-block* or *Base Station RF Bandwidth*.

NOTE 3: This frequency range ensures that the range of values of f_{offset} is continuous.

Table 4.3.3.2-6: Spectrum emission mask, $31 \text{ dBm} \leq P_{\text{rated,c,cell}} - 10 \times \log_{10}(N_{\text{TXU,countedpercell}}) < 39 \text{ dBm}$ for UTRA bands $> 3 \text{ GHz}$

Frequency offset of measurement filter -3 dB point, Δf	Frequency offset of measurement filter centre frequency, f_{offset}	<i>basic limit</i> (notes 1 and 2)	<i>Measurement bandwidth</i>
$2,5 \text{ MHz} \leq \Delta f < 2,7 \text{ MHz}$	$2,515 \text{ MHz} \leq f_{\text{offset}} < 2,715 \text{ MHz}$	$P_{\text{rated,c,cell}} - 10 \times \log_{10}(N_{\text{TXU,countedpercell}}) - 51,2 \text{ dBm}$	30 kHz
$2,7 \text{ MHz} \leq \Delta f < 3,5 \text{ MHz}$	$2,715 \text{ MHz} \leq f_{\text{offset}} < 3,515 \text{ MHz}$	$P_{\text{rated,c,cell}} - 10 \times \log_{10}(N_{\text{TXU,countedpercell}}) - 51,2 - 15 \times (f_{\text{offset}} - 2,715) \text{ dBm}$	30 kHz
(note 3)	$3,515 \text{ MHz} \leq f_{\text{offset}} < 4,0 \text{ MHz}$	$P_{\text{rated,c,cell}} - 10 \times \log_{10}(N_{\text{TXU,countedpercell}}) - 63,2 \text{ dBm}$	30 kHz
$3,5 \text{ MHz} \leq \Delta f < 7,5 \text{ MHz}$	$4,0 \text{ MHz} \leq f_{\text{offset}} < 8,0 \text{ MHz}$	$P_{\text{rated,c,cell}} - 10 \times \log_{10}(N_{\text{TXU,countedpercell}}) - 50,2 \text{ dBm}$	1 MHz
$7,5 \text{ MHz} \leq \Delta f \leq \Delta f_{\text{max}}$	$8,0 \text{ MHz} \leq f_{\text{offset}} < f_{\text{offset}_{\text{max}}}$	$P_{\text{rated,c,cell}} - 10 \times \log_{10}(N_{\text{TXU,countedpercell}}) - 54,2 \text{ dBm}$	1 MHz
<p>NOTE 1: For TAB connectors supporting <i>non-contiguous spectrum</i> operation the <i>basic limit</i> within <i>sub-block gaps</i> within any <i>operating band</i> is calculated as a cumulative sum of contributions from adjacent sub-blocks on each side of the <i>sub-block gap</i>, where the contribution from the far-end <i>sub-block</i> shall be scaled according to the <i>measurement bandwidth</i> of the near-end <i>sub-block</i>. Exception is $\Delta f \geq 12,5 \text{ MHz}$ from both adjacent sub-blocks on each side of the <i>sub-block gap</i>, where <i>basic limit</i> $P_{\text{rated,c,cell}} - 10 \times \log_{10}(N_{\text{TXU,countedpercell}}) - 54,2 \text{ dBm/MHz}$.</p> <p>NOTE 2: For <i>multi-band TAB connectors</i> with <i>Inter RF Bandwidth gap</i> $< 2 \times \Delta f_{\text{OBUE}}$ MHz the limit within the <i>Inter RF Bandwidth gaps</i> is calculated as a cumulative sum of contributions from adjacent <i>sub-blocks</i> or <i>Base Station RF Bandwidth</i> on each side of the <i>Inter RF Bandwidth gap</i>, where the contribution from the far-end <i>sub-block</i> or <i>Base Station RF Bandwidth</i> shall be scaled according to the <i>measurement bandwidth</i> of the near-end <i>sub-block</i> or <i>Base Station RF Bandwidth</i>.</p> <p>NOTE 3: This frequency range ensures that the range of values of f_{offset} is continuous.</p>			

Table 4.3.3.2-7: Spectrum emission mask, $P_{\text{rated,c,cell}} - 10 \times \log_{10}(N_{\text{TXU,countedpercell}}) < 39 \text{ dBm}$ for UTRA bands $\leq 3 \text{ GHz}$

Frequency offset of measurement filter -3 dB point, Δf	Frequency offset of measurement filter centre frequency, f_{offset}	<i>basic limit</i> (notes 1 and 2)	<i>Measurement bandwidth</i>
$2,5 \text{ MHz} \leq \Delta f < 2,7 \text{ MHz}$	$2,515 \text{ MHz} \leq f_{\text{offset}} < 2,715 \text{ MHz}$	-20,5 dBm	30 kHz
$2,7 \leq \Delta f < 3,5 \text{ MHz}$	$2,715 \text{ MHz} \leq f_{\text{offset}} < 3,515 \text{ MHz}$	$-20,5 - 15 \times (f_{\text{offset}} - 2,715) \text{ dBm}$	30 kHz
(note 3)	$3,515 \text{ MHz} \leq f_{\text{offset}} < 4,0 \text{ MHz}$	-32,5 dBm	30 kHz
$3,5 \text{ MHz} \leq \Delta f < 7,5 \text{ MHz}$	$4,0 \text{ MHz} \leq f_{\text{offset}} < 8,0 \text{ MHz}$	-19,5 dBm	1 MHz
$7,5 \text{ MHz} \leq \Delta f \leq \Delta f_{\text{max}}$	$8,0 \text{ MHz} \leq f_{\text{offset}} < f_{\text{offset}_{\text{max}}}$	-23,5 dBm	1 MHz
<p>NOTE 1: For TAB connectors supporting <i>non-contiguous spectrum</i> operation the <i>basic limit</i> within <i>sub-block gaps</i> within any <i>operating band</i> is calculated as a cumulative sum of contributions from adjacent sub-blocks on each side of the <i>sub-block gap</i>, where the contribution from the far-end <i>sub-block</i> shall be scaled according to the <i>measurement bandwidth</i> of the near-end <i>sub-block</i>. Exception is $\Delta f \geq 12,5 \text{ MHz}$ from both adjacent sub-blocks on each side of the <i>sub-block gap</i>, where <i>basic limit</i> within <i>sub-block gaps</i> shall be -23,5 dBm/MHz.</p> <p>NOTE 2: For <i>multi-band TAB connectors</i> with <i>Inter RF Bandwidth gap</i> $< 2 \times \Delta f_{\text{OBUE}}$ MHz the limit within the <i>Inter RF Bandwidth gaps</i> is calculated as a cumulative sum of contributions from adjacent <i>sub-blocks</i> or <i>Base Station RF Bandwidth</i> on each side of the <i>Inter RF Bandwidth gap</i>, where the contribution from the far-end <i>sub-block</i> or <i>Base Station RF Bandwidth</i> shall be scaled according to the <i>measurement bandwidth</i> of the near-end <i>sub-block</i> or <i>Base Station RF Bandwidth</i>.</p> <p>NOTE 3: This frequency range ensures that the range of values of f_{offset} is continuous.</p>			

Table 4.3.3.2-8: Spectrum emission mask, $P_{\text{rated,c,cell}} - 10 \times \log_{10}(N_{\text{TXU,countedpercell}}) < 31$ dBm for UTRA bands > 3 GHz

Frequency offset of measurement filter -3 dB point, Δf	Frequency offset of measurement filter centre frequency, f_{offset}	<i>basic limit</i> (notes 1 and 2)	<i>Measurement bandwidth</i>
$2,5 \text{ MHz} \leq \Delta f < 2,7 \text{ MHz}$	$2,515 \text{ MHz} \leq f_{\text{offset}} < 2,715 \text{ MHz}$	-20,2 dBm	30 kHz
$2,7 \leq \Delta f < 3,5 \text{ MHz}$	$2,715 \text{ MHz} \leq f_{\text{offset}} < 3,515 \text{ MHz}$	$-20,2 - 15 \times (f_{\text{offset}} - 2,715) \text{ dBm}$	30 kHz
(note 3)	$3,515 \text{ MHz} \leq f_{\text{offset}} < 4,0 \text{ MHz}$	-32,2 dBm	30 kHz
$3,5 \text{ MHz} \leq \Delta f < 7,5 \text{ MHz}$	$4,0 \text{ MHz} \leq f_{\text{offset}} < 8,0 \text{ MHz}$	-19,2 dBm	1 MHz
$7,5 \text{ MHz} \leq \Delta f \leq \Delta f_{\text{max}}$	$8,0 \text{ MHz} \leq f_{\text{offset}} < f_{\text{offset}_{\text{max}}}$	-23,2 dBm	1 MHz

NOTE 1: For TAB connectors supporting *non-contiguous spectrum* operation the *basic limit* within *sub-block gaps* within any *operating band* is calculated as a cumulative sum of contributions from adjacent sub-blocks on each side of the *sub-block gap*, where the contribution from the far-end *sub-block* shall be scaled according to the *measurement bandwidth* of the near-end *sub-block*. Exception is $\Delta f \geq 12,5$ MHz from both adjacent sub-blocks on each side of the *sub-block gap*, where *basic limit* within *sub-block gaps* shall be -23,2 dBm/MHz.

NOTE 2: For *multi-band TAB connectors* with *Inter RF Bandwidth gap* $< 2 \times \Delta f_{\text{OBUe}}$ MHz the limit within the *Inter RF Bandwidth gaps* is calculated as a cumulative sum of contributions from adjacent *sub-blocks* or *Base Station RF Bandwidth* on each side of the *Inter RF Bandwidth gap*, where the contribution from the far-end *sub-block* or *Base Station RF Bandwidth* shall be scaled according to the *measurement bandwidth* of the near-end *sub-block* or *Base Station RF Bandwidth*.

NOTE 3: This frequency range ensures that the range of values of f_{offset} is continuous.

For a BS operating in band XX, additional limits for protection of DTT are described in clause 6.6.4.5.2.1 of ETSI TS 137 145-1 [2]. This statement is provided for information and does not have any impact on the conformance requirements or essential radio test suites in the present document.

For a BS operating in band XXXII, additional limits are described in clause 6.6.4.5.2.1 of ETSI TS 137 145-1 [2]. This statement is provided for information and does not have any impact on the conformance requirements or essential radio test suites in the present document.

4.3.3.3 Conformance

The conformance tests for this requirement shall be as defined in clause 5.3.3 of the present document.

4.3.4 Adjacent Channel Leakage power Ratio (ACLR)

4.3.4.1 Definition and applicability

Adjacent Channel Leakage power Ratio (ACLR) is the ratio of the filtered mean power centred on the assigned channel frequency to the filtered mean power centred on an adjacent channel frequency.

The ACLR is defined with a square filter of bandwidth equal to the *transmission bandwidth* configuration of the transmitted signal (BW_{Config}) centred on the assigned channel frequency and a filter centred on the adjacent channel frequency.

The Cumulative Adjacent Channel Leakage power Ratio (CACLR) in a *sub-block gap* or the *Inter RF Bandwidth gap* is the ratio of:

- the sum of the filtered mean power centred on the assigned channel frequencies for the two carriers adjacent to each side of the *sub-block gap* or the *Inter RF Bandwidth gap*; and
- the filtered mean power centred on a frequency channel adjacent to one of the respective *sub-block edges* or *Base Station RF Bandwidth edges*.

The requirements shall apply outside the *Base Station RF Bandwidth* or *Maximum Radio Bandwidth* whatever the type of transmitter considered (single carrier or multi-carrier) and for all transmission modes foreseen by the manufacturer's specification.

The requirement applies during the *transmitter ON period*.

In case of WCDMA signals, as described in ETSI TS 125 141 [7], the RRC pulse-shaping filter on the adjacent channel frequency is a root-raised cosine with roll-off $\alpha = 0,22$ in the frequency domain. The impulse response of the chip impulse filter $RC_0(t)$ is:

$$RC_0(t) = \frac{\sin\left(\pi\frac{t}{T_C}(1-\alpha)\right) + 4\alpha\frac{t}{T_C}\cos\left(\pi\frac{t}{T_C}(1+\alpha)\right)}{\pi\frac{t}{T_C}\left(1 - \left(4\alpha\frac{t}{T_C}\right)^2\right)}$$

Where the roll-off factor $\alpha = 0,22$ and the chip duration:

$$T_C = \frac{1}{\text{chiprate}}$$

4.3.4.2 Limits

4.3.4.2.1 General

The ACLR/CACLR absolute limits in clause 4.3.4.2.2 or the ACLR/CACLR relative limits in clauses 4.3.4.2.3, 4.3.4.2.4 and 4.3.4.2.5, whichever is less stringent, shall apply for each *TAB connector TX min cell group*.

4.3.4.2.2 Absolute limits

The filtered mean power centred on an adjacent channel frequency shall not exceed a limit which is the the absolute basic limit in table 4.3.4.2.2-1 + X, where $X = 10\log_{10}(N_{\text{TXU, counted per cell}})$

Table 4.3.4.2.2-1: ACLR/CACLR absolute basic limit

BS class	ACLR/CACLR absolute basic limit
Wide Area BS	-15 dBm/MHz
Medium Range BS	-25 dBm/MHz
Local Area BS	-32 dBm/MHz

4.3.4.2.3 Relative limits for *MSR operation*

4.3.4.2.3.1 Limits for E-UTRA operation

For a *TAB connectors* supporting *MSR operation*, the ACLR limits for E-UTRA carriers are specified below.

For *TAB connectors* operating in *non-contiguous spectrum*, the ACLR also applies for the first adjacent channel inside any *sub-block gap* with a gap size $W_{\text{gap}} \geq 15$ MHz. The ACLR limit for the second adjacent channel applies inside any *sub-block gap* with a gap size $W_{\text{gap}} \geq 20$ MHz. The CACLR limit in clause 4.3.4.2.5.2 applies in *sub-block gaps* for the frequency ranges defined in tables 4.3.4.2.5.2-1 and 4.3.4.2.5.2-2.

For *multi-band TAB connectors*, the ACLR also applies for the first adjacent channel inside any *Inter RF Bandwidth gap* with a gap size $W_{\text{gap}} \geq 15$ MHz. The ACLR limit for the second adjacent channel applies inside any *Inter RF Bandwidth gap* with a gap size $W_{\text{gap}} \geq 20$ MHz. The CACLR limit in clause 4.3.4.2.5.2 applies in *Inter RF Bandwidth gaps* for the frequency ranges defined in tables 4.3.4.2.5.2-1 and and 4.3.4.2.5.2-2.

For operation in paired spectrum, the ACLR shall not be less than the limit specified in table 4.3.4.2.3.1-1.

Table 4.3.4.2.3.1-1: Limits for E-UTRA ACLR in paired spectrum

Channel bandwidth of E-UTRA Lowest/Highest Carrier transmitted BW_{Channel} (MHz)	Adjacent channel centre frequency offset below the lower or above the upper Base Station RF Bandwidth edge	Assumed adjacent channel carrier	Filter on the adjacent channel frequency and filter bandwidth	ACLR limit
1,4; 3; 5; 10; 15; 20	0,5 x BW_{Channel}	E-UTRA of same BW	Square (BW_{Config})	44,2 dB
	1,5 x BW_{Channel}	E-UTRA of same BW	Square (BW_{Config})	44,2 dB
	2,5 MHz	3,84 Mcps UTRA	RRC (3,84 Mcps)	44,2 dB
	7,5 MHz	3,84 Mcps UTRA	RRC (3,84 Mcps)	44,2 dB
NOTE: BW_{Channel} and BW_{Config} are the <i>channel bandwidth</i> and <i>transmission bandwidth</i> configuration of the E-UTRA Lowest/Highest Carrier transmitted on the assigned channel frequency.				

For operation in unpaired spectrum, the ACLR shall not be less than the limit specified in table 4.3.4.2.3.1-2.

Table 4.3.4.2.3.1-2: Limits for E-UTRA ACLR in unpaired spectrum with *synchronized operation*

Channel bandwidth of E-UTRA Lowest/Highest Carrier transmitted BW_{Channel} (MHz)	adjacent channel centre frequency offset below the lower or above the upper Base Station RF Bandwidth edge	Assumed adjacent channel carrier	Filter on the adjacent channel frequency and filter bandwidth	ACLR limit
1,4; 3	0,5 x BW_{Channel}	E-UTRA of same BW	Square (BW_{Config})	44,2 dB
	1,5 x BW_{Channel}	E-UTRA of same BW	Square (BW_{Config})	44,2 dB
	0,8 MHz	1,28 Mcps UTRA	RRC (1,28 Mcps)	44,2 dB
	2,4 MHz	1,28 Mcps UTRA	RRC (1,28 Mcps)	44,2 dB
5; 10; 15; 20	0,5 x BW_{Channel}	E-UTRA of same BW	Square (BW_{Config})	44,2 dB
	1,5 x BW_{Channel}	E-UTRA of same BW	Square (BW_{Config})	44,2 dB
	0,8 MHz	1,28 Mcps UTRA	RRC (1,28 Mcps)	44,2 dB
	2,4 MHz	1,28 Mcps UTRA	RRC (1,28 Mcps)	44,2 dB
	2,5 MHz	3,84 Mcps UTRA	RRC (3,84 Mcps)	44,2 dB
	7,5 MHz	3,84 Mcps UTRA	RRC (3,84 Mcps)	44,2 dB
	5 MHz	7,68 Mcps UTRA	RRC (7,68 Mcps)	44,2 dB
15 MHz	7,68 Mcps UTRA	RRC (7,68 Mcps)	44,2 dB	
NOTE: BW_{Channel} and BW_{Config} are the <i>channel bandwidth</i> and <i>transmission bandwidth</i> configuration of the E-UTRA Lowest/Highest Carrier transmitted on the assigned channel frequency.				

For operation in non-contiguous paired spectrum, the ACLR shall not be less than the limit specified in table 4.3.4.2.3.1-3.

Table 4.3.4.2.3.1-3: Limits for E-UTRA ACLR in non-contiguous paired spectrum

Sub-block gap size (W_{gap}) where the limit applies	Adjacent channel centre frequency offset below or above the sub-block edge (inside the gap)	Assumed adjacent channel carrier	Filter on the adjacent channel frequency and filter bandwidth	ACLR limit
$W_{\text{gap}} \geq 15$ MHz	2,5 MHz	3,84 Mcps UTRA	RRC (3,84 Mcps)	44,2 dB
$W_{\text{gap}} \geq 20$ MHz	7,5 MHz	3,84 Mcps UTRA	RRC (3,84 Mcps)	44,2 dB

For operation in non-contiguous unpaired spectrum, the ACLR shall not be less than the limit specified in table 4.3.4.2.3.1-4.

Table 4.3.4.2.3.1-4: Limits for E-UTRA ACLR in non-contiguous unpaired spectrum

Sub-block gap size (W_{gap}) where the limit applies	BS adjacent channel centre frequency offset below or above the sub-block edge (inside the gap)	Assumed adjacent channel carrier	Filter on the adjacent channel frequency and filter bandwidth	ACLR limit
$W_{\text{gap}} \geq 15$ MHz	2,5 MHz	5 MHz E-UTRA	Square (BW_{Config})	44,2 dB
$W_{\text{gap}} \geq 20$ MHz	7,5 MHz	5 MHz E-UTRA	Square (BW_{Config})	44,2 dB

4.3.4.2.3.2 Limits for NR operation

For *TAB connectors* supporting *MSR operation*, the ACLR limits for NR carriers are specified below.

For *TAB connectors* operating in *non-contiguous spectrum*, the ACLR limit also applies for the first adjacent channel inside any *sub-block gap* with a gap size as indicated in table 4.3.4.2.3.2-2. The ACLR limit for the second adjacent channel applies inside any *sub-block gap* with a gap size as indicated in table 4.3.4.2.3.2-2. The CACLR limit in clause 4.3.4.2.3.4 applies in *sub-block gaps* for the frequency ranges defined in table 4.3.4.2.3.4-2.

For *multi-band TAB connectors*, the ACLR also applies for the first adjacent channel inside any *Inter RF Bandwidth gap* with a gap size as indicated in table 4.3.4.2.3.2-2. The ACLR limit for the second adjacent channel applies inside any *Inter RF Bandwidth gap* with a gap size as indicated in table 4.3.4.2.3.2-2. The CACLR limit in clause 4.3.4.2.3.4 applies in *sub-block gaps* for the frequency ranges defined in table 4.3.4.2.3.4-2.

For operation in paired or unpaired spectrum, the ACLR shall not be less than the limit specified in table 4.3.4.2.3.2-1.

Table 4.3.4.2.3.2-1: NR ACLR limit

BS channel bandwidth of lowest/highest NR carrier transmitted BW_{Channel} (MHz)	BS adjacent channel centre frequency offset below the <i>lowest</i>- or above the <i>highest</i> carrier centre frequency transmitted	Assumed adjacent channel carrier (informative)	Filter on the adjacent channel frequency and filter bandwidth	ACLR limit
5; 10; 15; 20	BW_{Channel}	NR of same BW (note 2)	Square (BW_{Config})	44,2 dB
	$2 \times BW_{\text{Channel}}$	NR of same BW (note 2)	Square (BW_{Config})	44,2 dB
	$BW_{\text{Channel}}/2 + 2,5 \text{ MHz}$	5 MHz E-UTRA	Square (4,5 MHz)	44,2 dB (note 3)
	$BW_{\text{Channel}}/2 + 7,5 \text{ MHz}$	5 MHz E-UTRA	Square (4,5 MHz)	44,2 dB (note 3)
25; 30; 40; 50; 60; 70; 80; 90; 100	BW_{Channel}	NR of same BW (note 2)	Square (BW_{Config})	43,8 dB
	$2 \times BW_{\text{Channel}}$	NR of same BW (note 2)	Square (BW_{Config})	43,8 dB
	$BW_{\text{Channel}}/2 + 2,5 \text{ MHz}$	5 MHz E-UTRA	Square (4,5 MHz)	43,8 dB (note 3)
	$BW_{\text{Channel}}/2 + 7,5 \text{ MHz}$	5 MHz E-UTRA	Square (4,5 MHz)	43,8 dB (note 3)
NOTE 1: BW_{Channel} and BW_{Config} are the <i>BS channel bandwidth</i> and <i>transmission bandwidth</i> configuration of the lowest/highest NR carrier transmitted on the assigned channel frequency.				
NOTE 2: With SCS that provides largest <i>transmission bandwidth</i> configuration (BW_{Config}).				
NOTE 3: The requirements are applicable when the band is also defined for E-UTRA or UTRA.				

For operation in non-contiguous paired or unpaired spectrum, the ACLR shall not be less than the limit specified in table 4.3.4.2.3.2-2.

Table 4.3.4.2.3.2-2: NR ACLR limit in *non-contiguous spectrum* or multiple bands

BS channel bandwidth of NR carrier transmitted adjacent to sub-block gap or inter RF Bandwidth gap BW_{Channel} (MHz)	Sub-block or Inter RF Bandwidth gap size (W_{gap}) where the limit applies (MHz)	BS adjacent channel centre frequency offset below or above the sub-block or Base Station RF Bandwidth edge (inside the gap)	Assumed adjacent channel carrier	Filter on the adjacent channel frequency and filter bandwidth	ACLR limit
5; 10; 15; 20	$W_{\text{gap}} \geq 15$ (note 3) $W_{\text{gap}} \geq 45$ (note 4)	2,5 MHz	5 MHz NR (note 2)	Square (BW_{Config})	44,2 dB
	$W_{\text{gap}} \geq 20$ (note 3) $W_{\text{gap}} \geq 50$ (note 4)	7,5 MHz	5 MHz NR (note 2)		
25; 30; 40; 50; 60; 70; 80; 90; 100	$W_{\text{gap}} \geq 60$ (note 4) $W_{\text{gap}} \geq 30$ (note 3)	10 MHz	20 MHz NR (note 2)	Square (BW_{Config})	43,8 dB
	$W_{\text{gap}} \geq 80$ (note 4) $W_{\text{gap}} \geq 50$ (note 3)	30 MHz	20 MHz NR (note 2)		

NOTE 1: BW_{Config} is the *transmission bandwidth* configuration of the assumed adjacent channel carrier.
NOTE 2: With SCS that provides largest *transmission bandwidth* configuration (BW_{Config}).
NOTE 3: Applicable in case the *BS channel bandwidth* of the carrier transmitted at the other edge of the gap is 5, 10, 15, 20 MHz.
NOTE 4: Applicable in case the *BS channel bandwidth* of the NR carrier transmitted at the other edge of the gap is 25, 30, 40, 50, 60, 70, 80, 90, 100 MHz.

4.3.4.2.3.3 Limits for UTRA operation

For *TAB connectors* supporting *MSR operation*, the ACLR limits for UTRA carriers are specified below.

For *TAB connectors* operating in *non-contiguous spectrum*, ACLR limit also applies for the first adjacent channel, inside any *sub-block gap* with a gap size $W_{\text{gap}} \geq 15$ MHz. The ACLR limit for the second adjacent channel applies inside any *sub-block gap* with a gap size $W_{\text{gap}} \geq 20$ MHz. The ACLR limit in clause 4.3.4.2.3.4 applies in *sub-block gaps* for the frequency ranges defined in table 4.3.4.2.3.4-1.

For *multi-band TAB connectors* ACLR limit also applies for the first adjacent channel, inside any *Inter RF Bandwidth gap* with a gap size $W_{\text{gap}} \geq 15$ MHz. The ACLR limit for the second adjacent channel applies inside any *Inter RF Bandwidth gap* with a gap size $W_{\text{gap}} \geq 20$ MHz. The ACLR limit in clause 4.3.4.2.3.4 applies in *Inter RF Bandwidth gaps* for the frequency ranges defined in table 4.3.4.2.3.4-1.

Table 4.3.4.2.3.3-1: UTRA ACLR limit

BS channel offset below the first or above the last carrier frequency used	ACLR limit
5 MHz	44,2 dB
10 MHz	49,2 dB

Table 4.3.4.2.3.3-2: UTRA ACLR limit in *non-contiguous spectrum* or multiple bands

Sub-block or Inter RF Bandwidth gap size (W_{gap}) where the limit applies	BS adjacent channel centre frequency offset below or above the sub-block edge or the Base Station RF Bandwidth edge (inside the gap)	Assumed adjacent channel carrier (informative)	Filter on the adjacent channel frequency and filter bandwidth	ACLR limit
$W_{\text{gap}} \geq 15$ MHz	2,5 MHz	3,84 Mcps UTRA	RRC (3,84 Mcps)	44,2 dB
$W_{\text{gap}} \geq 20$ MHz	7,5 MHz	3,84 Mcps UTRA	RRC (3,84 Mcps)	44,2 dB

4.3.4.2.3.4 CACLR limit in *non-contiguous spectrum*

The CACLR limit shall apply for *sub-block* or *Inter RF Bandwidth gap* sizes listed in table 4.3.4.2.3.4-1 for UTRA or E-UTRA operation, or table 4.3.4.2.3.4-2 for E-UTRA and NR operation:

- Inside a sub-block gap within an *operating band* for a BS operating in non-contiguous spectrum.
- Inside an Inter RF Bandwidth gap for a BS operating in multiple bands, where multiple bands are mapped on the same TAB connector.

The requirement applies to adjacent channels of E-UTRA or UTRA or NR carriers allocated adjacent to each side of the *sub-block gap* or the *Inter RF Bandwidth gap*. In case of mixed UTRA and E-UTRA (but not NR) carriers on either side of the gap, table 4.3.4.2.3.4-1 is applicable. In case of mixed NR and E-UTRA or UTRA or NR only carriers on either side of the gap, table 4.3.4.2.3.4-2 is applicable. The assumed filter for the adjacent channel frequency is defined in tables 4.3.4.2.3.4-1 and 4.3.4.2.3.4-2 and the filters on the assigned channels are defined in table 4.3.4.2.3.4-3.

NOTE: If the RAT on the assigned channel frequencies is different, the filters used are also different.

The CACLR for E-UTRA and UTRA carriers located on either side of the *sub-block gap* or the *Inter RF Bandwidth gap* shall not be less than the limit specified in table 4.3.4.2.3.4-1.

Table 4.3.4.2.3.4-1: CACLR in *non-contiguous spectrum* or multiple bands for UTRA and E-UTRA only

Band Category	<i>Sub-block</i> or <i>Inter RF Bandwidth gap</i> size (W_{gap}) where the limit applies	adjacent channel centre frequency offset below or above the <i>sub-block</i> edge or the <i>Base Station RF Bandwidth edge</i> (inside the gap)	Assumed adjacent channel carrier (informative)	Filter on the adjacent channel frequency and filter bandwidth	CACLR limit
BC1; BC2	$5 \text{ MHz} \leq W_{\text{gap}} < 15 \text{ MHz}$	2,5 MHz	3,84 Mcps UTRA	RRC (3,84 Mcps)	44,2 dB
BC1; BC2	$10 \text{ MHz} \leq W_{\text{gap}} < 20 \text{ MHz}$	7,5 MHz	3,84 Mcps UTRA	RRC (3,84 Mcps)	44,2 dB
BC3	$5 \text{ MHz} \leq W_{\text{gap}} < 15 \text{ MHz}$	2,5 MHz	5 MHz E-UTRA	Square (BW_{Config})	44,2 dB
BC3	$10 \text{ MHz} < W_{\text{gap}} < 20 \text{ MHz}$	7,5 MHz	5 MHz E-UTRA	Square (BW_{Config})	44,2 dB

Table 4.3.4.2.3.4-2: CACLR in *non-contiguous spectrum* or multiple bands for E-UTRA and NR combinations

<i>BS channel bandwidth</i> of lowest/highest NR carrier transmitted BW_{Channel} (MHz)	<i>Sub-block</i> or <i>Inter RF Bandwidth gap</i> size (W_{gap}) where the limit applies (MHz)	BS adjacent channel centre frequency offset below or above the <i>sub-block</i> or <i>Base Station RF Bandwidth edge</i> (inside the gap)	Assumed adjacent channel carrier	Filter on the adjacent channel frequency and filter bandwidth	CACLR limit
5; 10; 15; 20	$5 \leq W_{\text{gap}} < 15$ (note 3) $5 \leq W_{\text{gap}} < 45$ (note 4)	2,5 MHz	5 MHz NR (note 2)	Square (BW_{Config})	44,2 dB
	$10 < W_{\text{gap}} < 20$ (note 3) $10 \leq W_{\text{gap}} < 50$ (note 4)	7,5 MHz	5 MHz NR (note 2)		

BS channel bandwidth of lowest/highest NR carrier transmitted BW_{Channel} (MHz)	Sub-block or Inter RF Bandwidth gap size (W_{gap}) where the limit applies (MHz)	BS adjacent channel centre frequency offset below or above the sub-block or Base Station RF Bandwidth edge (inside the gap)	Assumed adjacent channel carrier	Filter on the adjacent channel frequency and filter bandwidth	CACLR limit
25; 30; 40; 50; 60; 70; 80; 90; 100	20 ≤ W _{gap} < 60 (note 4) 20 ≤ W _{gap} < 30 (note 3)	10 MHz	20 MHz NR (note 2)	Square (BW _{Config})	43,8 dB
	40 < W _{gap} < 80 (note 4) 40 ≤ W _{gap} < 50 (note 3)	30 MHz	20 MHz NR (note 2)		

NOTE 1: BW_{Config} is the *transmission bandwidth* configuration of the assumed adjacent channel carrier.
NOTE 2: With SCS that provides largest *transmission bandwidth* configuration (BW_{Config}).
NOTE 3: Applicable in case the *BS channel bandwidth* of the UTRA, E-UTRA or NR carrier transmitted at the other edge of the gap is 5, 10, 15, 20 MHz.
NOTE 4: Applicable in case the *BS channel bandwidth* of the NR carrier transmitted at the other edge of the gap is 25, 30, 40, 50, 60, 70, 80, 90, 100 MHz.

Table 4.3.4.2.3.4-3: Filter parameters for the assigned channel for UTRA, E-UTRA only combinations

RAT of the carrier adjacent to the sub-block or Inter RF Bandwidth gap	Filter on the assigned channel frequency and filter bandwidth
E-UTRA	E-UTRA of same BW
UTRA FDD	RRC (3,84 Mcps)

4.3.4.2.4 Relative limits for single RAT UTRA FDD operation

4.3.4.2.4.1 UTRA ACLR limit

The following limits apply for *TAB connectors* supporting only *single RAT UTRA operation*.

The ACLR limits are specified in tables 4.3.4.2.4.1-1 and 4.3.4.2.4.1-2.

Table 4.3.4.2.4.1-1: UTRA ACLR

BS channel offset below the first or above the last carrier frequency used	ACLR limit
5 MHz	44,2 dB
10 MHz	49,2 dB

Table 4.3.4.2.4.1-2: UTRA ACLR in *non-contiguous spectrum* or multiple bands

Sub-block or Inter RF Bandwidth gap size (W_{gap}) where the limit applies	adjacent channel centre frequency offset below or above the sub-block edge or the Base Station RF Bandwidth edge (inside the gap)	Assumed adjacent channel carrier (informative)	Filter on the adjacent channel frequency and filter bandwidth	ACLR limit
W _{gap} ≥ 15 MHz	2,5 MHz	3,84 Mcps UTRA	RRC (3,84 Mcps)	44,2 dB
W _{gap} ≥ 20 MHz	7,5 MHz	3,84 Mcps UTRA	RRC (3,84 Mcps)	44,2 dB

4.3.4.2.4.2 CACLR limit in *non-contiguous spectrum* or multiple-bands

The following limits apply for *TAB connectors* supporting only *single RAT UTRA operation*.

CACLR limits shall apply for *TAB connectors* operating in *non-contiguous spectrum* or multiple bands and for the gap sizes listed in table 4.3.4.2.4.2-1:

- inside a sub-block gap within an *operating band* for *TAB connectors* operating in *non-contiguous spectrum*;
- inside an *Inter RF Bandwidth gap* for multi-band *TAB connectors*.

The assumed filter for the adjacent channel frequency is defined in table 4.3.4.2.4.2-1 and the filters on the assigned channels are defined in table 4.3.4.2.4.2-2.

The CACLR for UTRA carriers located on either side of the *sub-block gap* or *Inter RF Bandwidth gap* shall not be less than the limit specified in table 4.3.4.2.4.2-1.

Table 4.3.4.2.4.2-1: CACLR in *non-contiguous spectrum* or multiple bands

<i>Sub-block or Inter RF Bandwidth gap size (W_{gap}) where the limit applies</i>	<i>BS adjacent channel centre frequency offset below or above the sub-block edge or the Base Station RF Bandwidth edge (inside the gap)</i>	<i>Assumed adjacent channel carrier (informative)</i>	<i>Filter on the adjacent channel frequency and filter bandwidth</i>	<i>CACLR limit</i>
$5 \text{ MHz} \leq W_{\text{gap}} < 15 \text{ MHz}$	2,5 MHz	3,84 Mcps UTRA	RRC (3,84 Mcps)	44,2 dB
$10 \text{ MHz} < W_{\text{gap}} < 20 \text{ MHz}$	7,5 MHz	3,84 Mcps UTRA	RRC (3,84 Mcps)	44,2 dB

Table 4.3.4.2.4.2-2: Filter parameters for the assigned channel

<i>RAT of the carrier adjacent to the sub-block or Inter RF Bandwidth gap</i>	<i>Filter on the assigned channel frequency and filter bandwidth</i>
UTRA FDD	RRC (3,84 Mcps)

4.3.4.2.5 Relative limits for E-UTRA operation

4.3.4.2.5.1 E-UTRA ACLR limit

The following limits apply for *TAB connectors* supporting only *single RAT E-UTRA operation*.

The ACLR is defined with a square filter of bandwidth equal to the *transmission bandwidth* configuration of the transmitted signal (BW_{Config}) centred on the assigned channel frequency and a filter centred on the adjacent channel frequency according to the tables below.

For operation in paired spectrum, the ACLR shall not be less than the limits specified in table 4.3.4.2.5.1-1.

Table 4.3.4.2.5.1-1: ACLR in paired spectrum

<i>Channel bandwidth of E-UTRA lowest/highest carrier transmitted BW_{Channel} (MHz)</i>	<i>adjacent channel centre frequency offset below the lowest- or above the highest carrier centre frequency transmitted</i>	<i>Assumed adjacent channel carrier (informative)</i>	<i>Filter on the adjacent channel frequency and filter bandwidth</i>	<i>ACLR limit</i>
1,4; 3; 5; 10; 15; 20	BW_{Channel}	E-UTRA of same BW	Square (BW_{Config})	44,2 dB
	$2 \times BW_{\text{Channel}}$	E-UTRA of same BW	Square (BW_{Config})	44,2 dB
	$BW_{\text{Channel}}/2 + 2,5 \text{ MHz}$	3,84 Mcps UTRA	RRC (3,84 Mcps)	44,2 dB
	$BW_{\text{Channel}}/2 + 7,5 \text{ MHz}$	3,84 Mcps UTRA	RRC (3,84 Mcps)	44,2 dB
NOTE : BW_{Channel} and BW_{Config} are the <i>channel bandwidth</i> and <i>transmission bandwidth</i> configuration of the E-UTRA lowest/highest/ carrier transmitted on the assigned channel frequency.				

For operation in unpaired spectrum, the ACLR shall not be less than the limits specified in table 4.3.4.2.5.1-2.

Table 4.3.4.2.5.1-2: ACLR in unpaired spectrum with *synchronized operation*

Channel bandwidth of E-UTRA lowest/highest carrier transmitted BW_{Channel} (MHz)	adjacent channel centre frequency offset below the lowest- or above the highest carrier centre frequency transmitted	Assumed adjacent channel carrier (informative)	Filter on the adjacent channel frequency and filter bandwidth	ACLR limit
1,4; 3	BW_{Channel}	E-UTRA of same BW	Square (BW_{Config})	44,2 dB
	$2 \times BW_{\text{Channel}}$	E-UTRA of same BW	Square (BW_{Config})	44,2 dB
	$BW_{\text{Channel}}/2 + 0,8 \text{ MHz}$	1,28 Mcps UTRA	RRC (1,28 Mcps)	44,2 dB
	$BW_{\text{Channel}}/2 + 2,4 \text{ MHz}$	1,28 Mcps UTRA	RRC (1,28 Mcps)	44,2 dB
5; 10; 15; 20	BW_{Channel}	E-UTRA of same BW	Square (BW_{Config})	44,2 dB
	$2 \times BW_{\text{Channel}}$	E-UTRA of same BW	Square (BW_{Config})	44,2 dB
	$BW_{\text{Channel}}/2 + 0,8 \text{ MHz}$	1,28 Mcps UTRA	RRC (1,28 Mcps)	44,2 dB
	$BW_{\text{Channel}}/2 + 2,4 \text{ MHz}$	1,28 Mcps UTRA	RRC (1,28 Mcps)	44,2 dB
	$BW_{\text{Channel}}/2 + 2,5 \text{ MHz}$	3,84 Mcps UTRA	RRC (3,84 Mcps)	44,2 dB
	$BW_{\text{Channel}}/2 + 7,5 \text{ MHz}$	3,84 Mcps UTRA	RRC (3,84 Mcps)	44,2 dB
	$BW_{\text{Channel}}/2 + 5 \text{ MHz}$	7,68 Mcps UTRA	RRC (7,68 Mcps)	44,2 dB
	$BW_{\text{Channel}}/2 + 15 \text{ MHz}$	7,68 Mcps UTRA	RRC (7,68 Mcps)	44,2 dB
NOTE : BW_{Channel} and BW_{Config} are the <i>channel bandwidth</i> and <i>transmission bandwidth</i> configuration of the E-UTRA lowest/highest carrier transmitted on the assigned channel frequency.				

For operation in non-contiguous paired spectrum or multiple bands, the ACLR shall not be less than the limits specified in table 4.3.4.2.5.1-3.

Table 4.3.4.2.5.1-3: ACLR in non-contiguous paired spectrum or multiple bands

Sub-block or Inter RF Bandwidth gap size (W_{gap}) where the limit applies	BS adjacent channel centre frequency offset below or above the sub-block edge or the Base Station RF Bandwidth edge (inside the gap)	Assumed adjacent channel carrier (informative)	Filter on the adjacent channel frequency and filter bandwidth	ACLR limit
$W_{\text{gap}} \geq 15 \text{ MHz}$	2,5 MHz	3,84 Mcps UTRA	RRC (3,84 Mcps)	44,2 dB
$W_{\text{gap}} \geq 20 \text{ MHz}$	7,5 MHz	3,84 Mcps UTRA	RRC (3,84 Mcps)	44,2 dB

For operation in non-contiguous unpaired spectrum or multiple bands, the ACLR shall not be less than the limits specified in table 4.3.4.2.5.1-4.

Table 4.3.4.2.5.1-4: ACLR in non-contiguous unpaired spectrum or multiple bands

Sub-block or Inter RF Bandwidth gap size (W_{gap}) where the limit applies	adjacent channel centre frequency offset below or above the sub-block edge or the Base Station RF Bandwidth edge (inside the gap)	Assumed adjacent channel carrier (informative)	Filter on the adjacent channel frequency and filter bandwidth	ACLR limit
$W_{\text{gap}} \geq 15 \text{ MHz}$	2,5 MHz	5 MHz E-UTRA	Square (BW_{Config})	44,2 dB
$W_{\text{gap}} \geq 20 \text{ MHz}$	7,5 MHz	5 MHz E-UTRA	Square (BW_{Config})	44,2 dB

4.3.4.2.5.2 CACLR limit in *non-contiguous spectrum*

The following limits apply for *TAB connectors* supporting only *single RAT E-UTRA operation*.

The CACLR limit shall apply for the *sub-block* or *Inter RF Bandwidth gap* sizes listed in table 4.3.4.2.5.2-1:

- Inside a sub-block gap within an *operating band* for a BS operating in non-contiguous spectrum.

- Inside an Inter RF Bandwidth gap for multi-band TAB connectors.

The assumed filter for the adjacent channel frequency is defined in tables 4.3.4.2.5.2-1 and 4.3.4.2.5.2-2. Filters on the assigned channels are defined in table 4.3.4.2.5.2-3.

For operation in *non-contiguous spectrum* or multiple bands, the CACLR for E-UTRA carriers located on either side of the *sub-block gap* or *Inter RF Bandwidth gap* shall not be less than the limits specified in tables 4.3.4.2.5.2-1 and 4.3.4.2.5.2-2.

Table 4.3.4.2.5.2-1: CACLR in non-contiguous paired spectrum or multiple bands

Sub-block or Inter RF Bandwidth gap size (W_{gap}) where the limit applies	BS adjacent channel centre frequency offset below or above the sub-block edge or the Base Station RF Bandwidth edge (inside the gap)	Assumed adjacent channel carrier (informative)	Filter on the adjacent channel frequency and filter bandwidth	CACLR limit
$5 \text{ MHz} \leq W_{\text{gap}} < 15 \text{ MHz}$	2,5 MHz	3,84 Mcps UTRA	RRC (3,84 Mcps)	44,2 dB
$10 \text{ MHz} < W_{\text{gap}} < 20 \text{ MHz}$	7,5 MHz	3,84 Mcps UTRA	RRC (3,84 Mcps)	44,2 dB

Table 4.3.4.2.5.2-2: CACLR in non-contiguous unpaired spectrum or multiple bands

Sub-block or Inter RF Bandwidth gap size (W_{gap}) where the limit applies	BS adjacent channel centre frequency offset below or above the sub-block edge or the Base Station RF Bandwidth edge (inside the gap)	Assumed adjacent channel carrier (informative)	Filter on the adjacent channel frequency and filter bandwidth	CACLR limit
$5 \text{ MHz} \leq W_{\text{gap}} < 15 \text{ MHz}$	2,5 MHz	5 MHz E-UTRA carrier	Square (BW_{Config})	44,2 dB
$10 \text{ MHz} < W_{\text{gap}} < 20 \text{ MHz}$	7,5 MHz	5 MHz E-UTRA carrier	Square (BW_{Config})	44,2 dB

Table 4.3.4.2.5.2-3: Filter parameters for the assigned channel

RAT of the carrier adjacent to the sub-block or Inter RF Bandwidth gap	Filter on the assigned channel frequency and filter bandwidth
E-UTRA	E-UTRA of same BW

4.3.4.3 Conformance

The conformance tests for this requirement shall be as defined in clause 5.3.4 of the present document.

4.3.5 Transmitter spurious emissions

4.3.5.1 Definition and applicability

The conducted transmitter spurious emission limits shall apply from 9 kHz to 12,75 GHz, or 5th harmonic limit of the downlink *operating band*, excluding the following RAT-specific frequency ranges:

- *MSR operation*: from Δf_{OBUE} below the lowest frequency of the *downlink operating band* up to Δf_{OBUE} above the highest frequency of the *downlink operating band*, where Δf_{OBUE} is defined in table 4.3.2.1-1.
- *Single RAT UTRA operation*: from 12,5 MHz below the *lowest carrier* frequency used up to 12,5 MHz above the *highest carrier* frequency used.
- *Single RAT E-UTRA operation*: from Δf_{OBUE} below the lowest frequency of the *downlink operating band* up to Δf_{OBUE} above the highest frequency of the *downlink operating band*, where Δf_{OBUE} is defined in table 4.3.2.1-1.

NOTE: For bands 7,22, 38, 41, 42, 43, 69, 77 and 78 the upper frequency limit is higher than 12,75 GHz in order to comply with the 5th harmonic limit of the *downlink operating band*, as specified in Recommendation ITU-R SM.329-12 [i.4].

Additional limits in clause 4.3.5.2.4 may apply closer than Δf_{OBUE} from the edges of *downlink operating band*.

For *multi-band TAB connectors*, each supported *operating band* together with Δf_{OBUE} around the band is excluded from the transmitter spurious emissions requirement.

The requirements applies for both single band and *multi-band TAB connectors* (except for frequencies at which exclusion bands or other multi-band provisions apply) and for all transmission modes foreseen by the manufacturer's specification. All limits are expressed as mean power (RMS).

The limits for protection of *BS receiver* shall be applied for FDD operation in order to prevent the receivers of own or a different BS being desensitized by emissions from the transmitter *TAB connectors*. Emissions are measured at the transmit *TAB connectors* for any type of *TAB connector* which has common or separate Tx/Rx antenna ports.

Additional spurious emissions limits shall be applied for the protection of system operating in frequency ranges other than the BS *downlink operating band*. The limits shall apply as a protection of such systems that are deployed in the same geographical area as the BS. Some limits shall apply for the protection of specific equipment (UE, MS and/or BS) or equipment operating in specific systems (GSM, CDMA, UTRA, E-UTRA, NR, etc.) as listed in clauses 4.3.5.2.3 and 4.3.5.2.4.

4.3.5.2 Limits

4.3.5.2.1 General spurious emissions limits

For each *TAB connector TX min cell group*, the power summation of the emissions at the *TAB connectors* of the *TAB connector TX min cell group* shall not exceed the *limits* specified in tables below.

For MSR and *single RAT E-UTRA operation* the limits are in table 4.3.5.2.1-1.

For *single RAT UTRA operation* the limits are in tables 4.3.5.2.1-2 and 4.3.5.2.1-3.

Table 4.3.5.2.1-1: Spurious emissions limits

Frequency range	Limit	Measurement Bandwidth	Notes
9 kHz ↔ 150 kHz	-36 dBm	1 kHz	Note 1
150 kHz ↔ 30 MHz	-36 dBm	10 kHz	Note 1
30 MHz ↔ 1 GHz	-36 dBm	100 kHz	Note 1
1 GHz ↔ 12,75 GHz	-30 dBm	1 MHz	Note 2
12,75 GHz ↔ 5 th harmonic of the upper frequency edge of the DL <i>operating band</i> in GHz	-30 dBm	1 MHz	Notes 2 and 3
NOTE 1: Bandwidth as in Recommendation ITU-R SM.329-12 [i.4], section 4.1.			
NOTE 2: Bandwidth as in Recommendation ITU-R SM.329-12 [i.4], section 4.1. Upper frequency as in Recommendation ITU-R SM.329-12 [i.4], section 2.5 table 1.			
NOTE 3: Applies only for Bands 22, 42, 43 and 48.			

Table 4.3.5.2.1-2: Mandatory spurious emissions *basic limits*, for UTRA operation in bands I, III, VII, XXXII

Band	Limit	Measurement Bandwidth	Notes
9 kHz ↔ 150 kHz	-36 dBm	1 kHz	Note 1
150 kHz ↔ 30 MHz	-36 dBm	10 kHz	Note 1
30 MHz ↔ 1 GHz	-36 dBm	100 kHz	Note 1
1 GHz ↔ $F_{low} - 10$ MHz	-30 dBm	1 MHz	Note 1
$F_{low} - 10$ MHz ↔ $F_{high} + 10$ MHz	-15 dBm	1 MHz	Note 2
$F_{high} + 10$ MHz ↔ 12,75 GHz	-30 dBm	1 MHz	Note 3
12,75 GHz - 5 th harmonic of the upper frequency edge of the DL <i>operating band</i> in GHz	-30 dBm	1 MHz	Notes 3 and 4
NOTE 1: Bandwidth as in Recommendation ITU-R SM.329-12 [i.4], section 4.1.			
NOTE 2: Limit based on Recommendation ITU-R SM.329-12 [i.4], section 4.3 and annex 7.			
NOTE 3: Bandwidth as in Recommendation ITU-R SM.329-12 [i.4], section 4.1. Upper frequency as in Recommendation ITU-R SM.329-12 [i.4], section 2.5 table 1.			
NOTE 4: Applies only for Band XXII.			
Key:			
F_{low} : The lowest downlink frequency of the <i>operating band</i> as defined in table 1-1.			
F_{high} : The highest downlink frequency of the <i>operating band</i> as defined in table 1-1.			

Table 4.3.5.2.1-3: Mandatory spurious emissions *basic limits*, for UTRA operation in bands VIII, XX

Band	Limit	Measurement Bandwidth	Notes
9 kHz ↔ 150 kHz	-36 dBm	1 kHz	Note 1
150 kHz ↔ 30 MHz	-36 dBm	10 kHz	Note 1
30 MHz ↔ $F_{low} - 10$ MHz	-36 dBm	100 kHz	Note 1
$F_{low} - 10$ MHz ↔ $F_{high} + 10$ MHz	-16 dBm	100 kHz	Note 2
$F_{high} + 10$ MHz ↔ 1 GHz	-36 dBm	100 kHz	Note 1
1 GHz ↔ 12,75 GHz	-30 dBm	1 MHz	Note 3
NOTE 1: Bandwidth as in Recommendation ITU-R SM.329-12 [i.4], section 4.1.			
NOTE 2: Limit based on Recommendation ITU-R SM.329-12 [i.4], section 4.3 and annex 7.			
NOTE 3: Bandwidth as in Recommendation ITU-R SM.329-12 [i.4], section 4.1. Upper frequency as in Recommendation ITU-R SM.329-12 [i.4], section 2.5 table 1.			
Key:			
F_{low} : The lowest downlink frequency of the <i>operating band</i> as defined in table 1-1.			
F_{high} : The highest downlink frequency of the <i>operating band</i> as defined in table 1-1.			

4.3.5.2.2 Limits for protection of the *BS receiver*

For each *TAB connector TX min cell group*, the power summation of the emissions at the *TAB connectors* of the *TAB connector TX min cell group* shall not exceed the *basic limit* + X, where $X = 10\log_{10}(N_{TXU, counted per cell})$.

For *MSR operation* the limits are specified in table 4.3.5.2.2-1.

Table 4.3.5.2.2-1: Spurious emissions *basic limits* for protection of the *BS receiver*

BS class	Band Category	Frequency range	MSR <i>basic limit</i>	Measurement bandwidth
Wide Area BS	BC1	$F_{UL_low} - F_{UL_high}$	-96 dBm	100 kHz
Wide Area BS	BC2	$F_{UL_low} - F_{UL_high}$	-98 dBm	100 kHz
Medium Range BS	BC1, BC2	$F_{UL_low} - F_{UL_high}$	-91 dBm	100 kHz
Local Area BS	BC1, BC2	$F_{UL_low} - F_{UL_high}$	-88 dBm	100 kHz
NOTE: For Band 28 BS, this requirement shall only apply in the uplink frequency range where the <i>BS receiver</i> is allowed to operate according to table 1-1.				

For UTRA and E-UTRA operation the limits are specified in table 4.3.5.2.2-2.

Table 4.3.5.2.2-2: Spurious emissions *basic limits* for protection of the *BS receiver*

BS class	Frequency range	UTRA <i>basic limit</i>	E-UTRA <i>basic limit</i>	<i>Measurement bandwidth</i>
Wide Area BS	F _{UL_low} - F _{UL_high}	-96 dBm	-96 dBm	100 kHz
Medium Range BS	F _{UL_low} - F _{UL_high}	-86 dBm	-91 dBm	100 kHz
Local Area BS	F _{UL_low} - F _{UL_high}	-82 dBm	-88 dBm	100 kHz
NOTE: For BS operating in band 28, this requirement shall only apply in the uplink frequency range where the <i>BS receiver</i> is allowed to operate according to table 1-1.				

4.3.5.2.3 Limits for co-existence with other systems

For each *TAB connector TX min cell group*, the power summation of the emissions at the *TAB connectors* of the *TAB connector TX min cell group* shall not exceed the *basic limit* + X, where $X = 10\log_{10}(N_{TXU, \text{counted per cell}})$.

Table 4.3.5.2.3-1: Spurious emissions *basic limits* for co-existence with systems operating in other frequency bands

System type operating in the same geographical area	Band for co-existence requirement	<i>Basic limit</i>	<i>Measurement Bandwidth</i>	Notes
GSM900	921 MHz to 960 MHz	-57 dBm	100 kHz	This requirement shall not apply to AAS BS operating in band 8.
	876 MHz to 915 MHz	-61 dBm	100 kHz	For the frequency range 880-915 MHz, this requirement shall not apply to AAS BS operating in band 8, since it is already covered by the requirement in clause 4.3.5.2.2.
DCS1800	1 805 MHz to 1 880 MHz	-47 dBm	100 kHz	This requirement shall not apply to AAS BS operating in band 3.
	1 710 MHz to 1 785 MHz	-61 dBm	100 kHz	This requirement shall not apply to AAS BS operating in band 3, since it is already covered by the requirement in clause 4.3.5.2.2.
UTRA FDD Band I or E-UTRA Band 1 or NR band n1	2 110 MHz to 2 170 MHz	-52 dBm	1 MHz	This requirement shall not apply to AAS BS operating in band 1.
	1 920 MHz to 1 980 MHz	-49 dBm	1 MHz	This requirement shall not apply to AAS BS operating in band 1, since it is already covered by the requirement in clause 4.3.5.2.2.
UTRA FDD Band III or E-UTRA Band 3 or NR band n3	1 805 MHz to 1 880 MHz	-52 dBm	1 MHz	This requirement shall not apply to AAS BS operating in band 3.
	1 710 MHz to 1 785 MHz	-49 dBm	1 MHz	This requirement shall not apply to AAS BS operating in band 3, since it is already covered by the requirement in clause 4.3.5.2.2.
UTRA FDD Band VII or E-UTRA Band 7 or NR band n7	2 620 MHz to 2 690 MHz	-52 dBm	1 MHz	This requirement shall not apply to AAS BS operating in band 7, since it is already covered by the requirement in clause 4.3.5.2.2.
	2 500 MHz to 2 570 MHz	-49 dBm	1 MHz	This requirement shall not apply to AAS BS operating in band 7, since it is already covered by the requirement in clause 4.3.5.2.2.
UTRA FDD Band VIII or E-UTRA Band 8 or NR band n8	925 MHz to 960 MHz	-52 dBm	1 MHz	This requirement shall not apply to AAS BS operating in band 8.
	880 MHz to 915 MHz	-49 dBm	1 MHz	This requirement shall not apply to AAS BS operating in band 8, since it is already covered by the requirement in clause 4.3.5.2.2.
UTRA FDD Band XX or E-UTRA Band 20 or NR band n20	791 MHz to 821 MHz	-52 dBm	1 MHz	This requirement shall not apply to AAS BS operating in band 20.
	832 MHz to 862 MHz	-49 dBm	1 MHz	This requirement shall not apply to AAS BS operating in band 20, since it is already covered by the requirement in clause 4.3.5.2.2.

System type operating in the same geographical area	Band for co-existence requirement	Basic limit	Measurement Bandwidth	Notes
UTRA FDD Band XXII or E-UTRA Band 22	3 510 MHz to 3 590 MHz	-52 dBm	1 MHz	This requirement shall not apply to AAS BS operating in band 22, 42, 77 or 78.
	3 410 MHz to 3 490 MHz	-49 dBm	1 MHz	This requirement shall not apply to AAS BS operating in band 22, 42, 77 or 78 since it is already covered by the requirement in clause 4.3.5.2.2.
E-UTRA Band 28 or NR band n28	758 MHz to 803 MHz	-52 dBm	1 MHz	This requirement shall not apply AAS BS operating in band 20, 28, 67 or 68.
	703 MHz to 748 MHz	-49 MHz	1 MHz	This requirement shall not apply to AAS BS operating in band 28, since it is already covered by the requirement in clause 4.3.5.2.2. For AAS BS operating in Band 67, it shall apply for 703 MHz to 736 MHz. For AAS BS operating in Band 68, it shall apply for 728 MHz to 733 MHz.
E-UTRA Band 31	462,5 MHz to 467,5 MHz	-52 dBm	1 MHz	This requirement shall not apply to AAS BS operating in band 31 or 72.
	452,5 MHz to 457,5 MHz	-49 dBm	1 MHz	This requirement shall not apply to AAS BS operating in band 31, since it is already covered by the requirement in clause 4.3.5.2.2. This requirement shall not apply to AAS BS operating in band 72.
UTRA FDD Band XXXII or E-UTRA Band 32	1 452 MHz to 1 496 MHz	-52 dBm	1 MHz	This requirement shall not apply to AAS BS operating in band 32.
UTRA TDD in Band a) or E-UTRA Band 33	1 900 MHz to 1 920 MHz	-52 dBm	1 MHz	This requirement shall not apply to AAS BS operating in band 33.
UTRA TDD in Band e) or E-UTRA Band 40 or NR band n40	2 300 MHz to 2 400 MHz	-52 dBm	1 MHz	This requirement shall not apply to AAS BS operating in band 40.
E-UTRA Band 42	3 400 MHz to 3 600 MHz	-52 dBm	1 MHz	This requirement shall not apply to AAS BS operating in band 22, 42 or 43 or 42.
E-UTRA Band 43	3 600 MHz to 3 800 MHz	-52 dBm	1 MHz	This requirement shall not apply to AAS BS operating in band 42 or 43.
E-UTRA Band 50 or NR band n50	1 432 MHz to 1 517 MHz	-52 dBm	1 MHz	This requirement shall not apply to AAS BS operating in band 50, 51, 75 or 76.
E-UTRA Band 51 or NR Band n51	1 427 MHz to 1 432 MHz	-52 dBm	1 MHz	This requirement shall not apply to AAS BS operating in band 50, 51, 75 or 76.
E-UTRA Band 65 or NR band n65	2 110 MHz to 2 200 MHz	-52 dBm	1 MHz	This requirement shall not apply to AAS BS operating in band 1 or 65.
	1 920 MHz to 2 010 MHz	-49 dBm	1 MHz	This requirement shall not apply to AAS BS operating in band 65, since it is already covered by the requirement in clause 4.3.5.2.2. For AAS BS operating in Band 1 the requirement shall apply for 1 980 MHz to 2 010 MHz, while the rest is covered in clause 4.3.5.2.2.
E-UTRA Band 67 or NR band n67	738 MHz to 758 MHz	-52 dBm	1 MHz	This requirement shall not apply to AAS BS operating in band 28 or 67.
E-UTRA Band 68	753 MHz to 783 MHz	-52 dBm	1 MHz	This requirement shall not apply to AAS BS operating in band 28 or 68.
	698 MHz to 728 MHz	-49 dBm	1 MHz	This requirement shall not apply to AAS BS operating in band 68, since it is already covered by the requirement in clause 4.3.5.2.2. For AAS BS operating in Band 28, the requirement shall apply between 698 MHz and 703 MHz, while the rest is covered in clause 4.3.5.2.2.
E-UTRA Band 69	2 570 MHz to 2 620 MHz	-52 dBm	1 MHz	This requirement shall not apply to AAS BS operating in Band 38 or 69.

System type operating in the same geographical area	Band for co-existence requirement	Basic limit	Measurement Bandwidth	Notes
E-UTRA Band 72 NR band n72	461 - 466 MHz	-52 dBm	1 MHz	This requirement shall not apply to AAS BS operating in band 31 or 72.
	451 - 456 MHz	-49 dBm	1 MHz	This requirement shall not apply to AAS BS operating in band 72, since it is already covered by the requirement in clause 4.3.5.2.2.
E-UTRA Band 75 or NR Band n75	1 432 MHz to 1 517 MHz	-52 dBm	1 MHz	This requirement shall not apply to AAS BS operating in band 50, 51, n75 or n76.
E-UTRA Band 76 or NR Band n76	1 427 MHz to 1 432 MHz	-52 dBm	1 MHz	This requirement shall not apply to AAS BS operating in band 50, 51, 75 or 76.
NR Band n77	3 300 MHz to 4 200 MHz	-52 dBm	1 MHz	This requirement shall not apply to AAS BS operating in band 22, 42, 43, 77 or 78.
NR Band n78	3 300 MHz to 3 800 MHz	-52 dBm	1 MHz	This requirement is not applicable to AAS BS operating in band 22, 42, 43, 77 or 78.
E-UTRA Band 87	420 MHz to 425 MHz	-52 dBm	1 MHz	This requirement shall not apply to AAS BS operating in band 87 or 88.
	410 MHz to 415 MHz	-49 dBm	1 MHz	This requirement shall not apply to AAS BS operating in band 87, since it is already covered by the requirement in clause 4.3.5.2.2.
E-UTRA Band 88	422 MHz to 427 MHz	-52 dBm	1 MHz	This requirement shall not apply to AAS BS operating in band 87 or 88.
	412 MHz to 417 MHz	-49 dBm	1 MHz	This requirement shall not apply to AAS BS operating in band 88, since it is already covered by the requirement in clause 4.3.5.2.2. This requirement shall not apply to AAS BS operating in band 87.
NR Band n91	1 427 MHz to 1 432 MHz	-52 dBm	1 MHz	This requirement shall not apply to AAS BS operating in band 50, 51, 75, 76, 91, 92, 93 or 94.
	832 MHz to 862 MHz	-49 dBm	1 MHz	This requirement shall not apply to AAS BS operating in band 20, since it is already covered by the requirement in clause 4.3.5.2.2.
NR Band n92	1 432 MHz to 1 517 MHz	-52 dBm	1 MHz	This requirement shall not apply to AAS BS operating in band 50, 51, 75, 76, 91, 92, 93 or 94.
	832 MHz to 862 MHz	-49 dBm	1 MHz	This requirement shall not apply to AAS BS operating in band 20, since it is already covered by the requirement in clause 4.3.5.2.2.
NR Band n93	1 427 MHz to 1 432 MHz	-52 dBm	1 MHz	This requirement shall not apply to AAS BS operating in Band 50, 51, 75, 76, 91, 92, 93 or 94.
	880 MHz to 915 MHz	-49 dBm	1 MHz	This requirement shall not apply to AAS BS operating in band 8, since it is already covered by the requirement in clause 4.3.5.2.2.
NR Band n94	1 432 MHz to 1 517 MHz	-52 dBm	1 MHz	This requirement shall not apply to AAS BS operating in Band 50, 51, 75, 76, 91, 92, 93 or 94.
	880 MHz to 915 MHz	-49 dBm	1 MHz	This requirement shall not apply to AAS BS operating in band 8, since it is already covered by the requirement in clause 4.3.5.2.2.
NOTE 1: Where the table has two entries for the same or overlapping frequency ranges, both limits shall be applied.				
NOTE 2: As set out in the definition in clause 4.3.5.1, except for the cases where the noted requirements apply to an AAS BS operating in band 28, the co-existence requirements in this table shall not apply for the 10 MHz frequency range immediately outside the downlink <i>operating band</i> (see table 1-1). This is also the case when the downlink <i>operating band</i> is adjacent to the band for the protected system in the table.				
NOTE 3: The co-existence requirement is specified for the full frequency range defined for band 32.				

4.3.5.2.4 Additional limits

The following requirement shall apply to AAS BS operating in bands 50 and 75 within 1 432 MHz - 1 452 MHz, and in bands 51 and 76. The limits are specified in table 4.3.5.2.4-1. This requirement is also applicable at the frequency range from Δf_{OBUE} below the lowest frequency of the BS downlink *operating band* up to Δf_{OBUE} above the highest frequency of the BS downlink *operating band*.

For each *TAB connector TX min cell group*, the power summation of the emissions at the *TAB connectors* of the *TAB connector TX min cell group* shall not exceed the *limit* specified in table 4.3.5.2.4-1.

Table 4.3.5.2.4-1: Additional emission limit for AAS BS operating in bands 50 and 75 within 1432-1452 MHz, and in bands 51 and 76

Filter centre frequency, filter	Limit	Measurement bandwidth
$F_{\text{filter}} = 1\,413,5\text{ MHz}$	-42 dBm	27 MHz

NOTE: For a AAS BS operating in bands 50 and 75 additional limits are described in table 6.6.5.5.4.6-4 in ETSI TS 137 145-1 [2]. This statement is provided for information and does not have any impact on the conformance requirements or essential radio test suites in the present document.

4.3.5.3 Conformance

The conformance tests for this requirement shall be as defined in clause 5.3.5 of the present document.

4.3.6 Base station maximum output power

4.3.6.1 Definition and applicability

This is an output power accuracy requirement defined at the *TAB connector* during the *transmitter ON period*.

For *BS* operating from 2 390 MHz to 2 400 MHz there is an additional requirement on the maximum output power.

The conducted Hybrid AAS BS output power requirements are specified at *single-band TAB connector* or at *multi-band TAB connector*.

NOTE: The *BS class specific rated carrier output power* limits are described in ETSI TS 137 145-1 [2], clause 6.2.2.1.

4.3.6.2 Limits

For each *single-band connector* or *multi-band TAB connector*, the maximum carrier output power $P_{\text{max,c,TABC}}$ shall remain within the values provided in table 4.3.6.2-1 for normal and extreme test environments, relative to $P_{\text{rated,c,TABC}}$ for *BS type 1-H* (D6.30).

Table 4.3.6.2-1: Requirements for conducted BS output power

BS type	Frequency	Normal test environment	Extreme test environment
Hybrid AAS BS	$f \leq 3,0\text{ GHz}$	$\pm 2,7\text{ dB}$	$\pm 3,2\text{ dB}$
	$3,0\text{ GHz} < f \leq 4,2\text{ GHz}$	$\pm 3,0\text{ dB}$	$\pm 3,5\text{ dB}$

In addition, for *BS* operating from 2 390 MHz to 2 400 MHz, for each *TAB connector TX min cell group*, the *maximum carrier output power* ($P_{\text{max,c,TABC}}$) shall not exceed 31 dBm/(5MHz). This limit is derived from AAS TRP limit in [i.22].

4.3.6.3 Conformance

The conformance tests for this requirement shall be as defined in clause 5.3.6 of the present document.

4.3.7 Transmit intermodulation

4.3.7.1 Definition and applicability

The transmitter intermodulation requirement is a measure of the capability of the transmitter unit to inhibit the generation of signals in its non-linear elements caused by presence of the wanted signal and an interfering signal reaching the transmitter unit via the RDN and antenna array. The requirement applies during the *transmitter ON period* and the *transmitter transient period*.

The requirement applies at each *TAB connector* supporting transmission in the *operating band*.

The transmitter intermodulation level is the power of the intermodulation products when an interfering signal is injected into the *TAB connector*.

For AAS BS there are two types of transmitter intermodulation cases captured by the transmitter intermodulation requirement:

- 1) Co-location transmitter intermodulation in which the interfering signal is from a co-located base station.
- 2) Intra-system transmitter intermodulation in which the interfering signal is from other transmitter units within the AAS BS.

4.3.7.2 Limits

4.3.7.2.1 Limits for *MSR operation*

4.3.7.2.1.1 General

The transmitter intermodulation level shall not exceed the unwanted emission limits specified for transmitter spurious emission in clause 4.3.5, *operating band unwanted emission* in clause 4.3.2, spectrum emission mask in clause 4.3.3 and ACLR in clause 4.3.4 in the presence of a wanted signal and an interfering signal according to table 4.3.7.2.1.1-1 for operation in BC1, BC2 and BC3.

The requirement is applicable outside the edges of the *Base Station RF Bandwidth*. The interfering signal offset is defined relative to the *Base Station RF Bandwidth edges* or *Maximum Radio Bandwidth edges*.

For *TAB connectors* supporting operation in *non-contiguous spectrum*, the requirement is also applicable inside a *sub-block gap* for interfering signal offsets where the interfering signal falls completely within the *sub-block gap*. The interfering signal offset is defined relative to the *sub-block edges*.

For *TAB connectors* supporting operation in multiple *operating bands*, the requirement applies relative to the *Base Station RF Bandwidth edges* of each *operating band*. In case the *inter RF Bandwidth gap* is less than 15 MHz, the requirement in the gap applies only for interfering signal offsets where the interfering signal falls completely within the *inter RF Bandwidth gap*.

Table 4.3.7.2.1.1-1: Interfering signal for the co-location transmitter intermodulation requirement

Parameter	Value
Wanted signal type	E-UTRA or NR signal
Interfering signal type	E-UTRA signal of <i>channel bandwidth</i> 5 MHz
Interfering signal power level	<i>Rated total output power per TAB connector in the operating band</i> ($P_{\text{Rated,t,TABC}}$) - 30 dB
Interfering signal centre frequency offset from <i>Base Station RF Bandwidth edge</i> or edge of <i>sub-block</i> inside a gap	±2,5 MHz ±7,5 MHz ±12,5 MHz
NOTE :	Interfering signal positions that are partially or completely outside of any <i>downlink operating band</i> of the <i>TAB connector</i> are excluded from the requirement, unless the interfering signal positions fall within the frequency range of adjacent <i>downlink operating bands</i> listed in table 1-1, In case that none of the interfering signal positions fall completely within the frequency range of the <i>downlink operating band</i> , the test suite in clause 5.3.7 provides further guidance.

4.3.7.2.1.2 Additional co-location limits (BC1 and BC2)

The transmitter intermodulation level shall not exceed the unwanted emission limits specified for transmitter spurious emission in clause 4.3.5, *operating band unwanted emission* in clause 4.3.2 and ACLR in clause 4.3.4 in the presence of a wanted signal and an interfering signal according to table 4.3.7.2.1.2-1 for *TAB connector* operation in BC2.

The requirement is applicable outside the *Base Station RF Bandwidth edges* for BC2. The interfering signal offset is defined relative to the *Base Station RF Bandwidth edges*.

For *TAB connectors* supporting operation in *non-contiguous spectrum* in BC1 or BC2, the requirement is also applicable inside a *sub-block gap* with a gap size not less than two times the interfering signal centre frequency offset. For *TAB connectors* supporting operation in *non-contiguous spectrum* in BC1, the requirement is not applicable inside a *sub-block gap* with a gap size equal to or more than 5 MHz. The interfering signal offset is defined relative to the *sub-block edges*.

For *TAB connectors* supporting operation in multiple *operating bands*, the requirement applies relative to the *Base Station RF Bandwidth edges* of a BC2 *operating band*. The requirement is also applicable for BC1 and BC2 inside an *inter RF Bandwidth gap* equal to or more than two times the interfering signal centre frequency offset. For *TAB connectors* supporting operation in multiple *operating bands*, the requirement is not applicable for BC1 band inside an *inter RF Bandwidth gap* with a gap size equal to or more than 5 MHz.

Table 4.3.7.2.1.2-1: Interfering signal for the co-location transmitter intermodulation requirement

Parameter	Value
Wanted signal type	E-UTRA or NR or UTRA signal
Interfering signal type	CW
Interfering signal power level	<i>Rated total output power per TAB connector in the operating band</i> ($P_{\text{Rated,t,TABC}}$) - 30 dB
Interfering signal centre frequency offset from <i>Base Station RF Bandwidth edge</i> or edge of <i>sub-block</i> inside a gap	> 800 kHz for CW interferer
NOTE: Interfering signal positions that are partially or completely outside of any <i>downlink operating band</i> of the <i>TAB connector</i> are excluded from the requirement.	

4.3.7.2.1.4 Intra-system limit

The transmitter intermodulation level shall not exceed the unwanted emission limits in clauses 4.3.2.2.1 (OBUE) and 4.3.4.2 (ACLR) in the presence of a co-channel interfering signal of the same configuration as the wanted signal. The interfering signal shall be incoherent with the wanted signal.

The interfering signal power level at each *TAB connector* is determined as the sum of the co-channel leakage power coupled via the combined RDN and Antenna Array from all the other *TAB connectors*, but does not comprise power radiated from the Antenna Array and reflected back from the environment. The power at each of the interfering *TAB connectors* is $P_{\text{rated,c,TABC}}$.

4.3.7.2.2 Limits for Single RAT UTRA operation

4.3.7.2.2.1 General

For *TAB connectors* supporting only *single RAT UTRA operation* the transmitter intermodulation level shall not exceed the out of band emission or the spurious emission requirements of clause 4.3.2 and clause 4.3.3 in the presence of interfering signal according to table 4.3.7.2.2.1-1.

For *TAB connectors* supporting operation in *non-contiguous spectrum*, the requirement is also applicable inside a *sub-block gap* for interfering signal offsets where the interfering signal falls completely within the *sub-block gap*. The interfering signal offset is defined relative to the *sub-block edges*.

For *TAB connectors* supporting operation in multiple *operating bands*, the requirement is also applicable inside an *Inter RF Bandwidth gap* for interfering signal offsets where the interfering signal falls completely within the *Base Station RF Bandwidth gap*.

Table 4.3.7.2.2.1-1: Interfering and wanted signal frequency offset for co-location requirement

Parameter	Value
Wanted signal type	UTRA
Interfering signal type	UTRA
Interfering signal power level	<i>Rated total output power per TAB connector in the operating band</i> ($P_{\text{Rated,t,TABC}}$) - 30 dB
Interfering signal centre frequency offset from the lower (upper) edge of the wanted signal or edge of <i>sub-block</i> inside a gap	-2,5 MHz -7,5 MHz -12,5 MHz +2,5 MHz +7,5 MHz +12,5 MHz
NOTE:	Interference frequencies that are outside of any allocated frequency band for UTRA-FDD downlink are excluded from the requirement, unless the interfering signal positions fall within the frequency range of adjacent <i>downlink operating bands</i> listed in table 1-1.

4.3.7.2.2.2 Intra-system limit

The transmitter intermodulation level shall not exceed the unwanted emission limits in clauses 4.3.3.2 (SEM) and 4.3.4.2 (ACLR) in the presence of a co-channel UTRA FDD interfering signal of the same configuration as the wanted signal. The interfering signal shall be incoherent with the wanted signal.

The interfering signal power level at each *TAB connector* is determined as the sum of the co-channel leakage power coupled via the combined RDN and Antenna Array from all the other *TAB connectors*, but does not comprise power radiated from the Antenna Array and reflected back from the environment. The power at each of the interfering *TAB connectors* is $P_{\text{rated,c,TABC}}$.

4.3.7.2.3 Limits for Single RAT E-UTRA operation

4.3.7.2.3.1 General

The transmitter intermodulation level shall not exceed the unwanted emission limits in clauses 4.3.2, 4.3.3 and 4.3.4 in the presence of an E-UTRA interfering signal according to table 4.3.7.2.3.1-1.

The requirement is applicable outside the *Base Station RF Bandwidth* or *Maximum Radio Bandwidth*. The interfering signal offset is defined relative to the *Base Station RF Bandwidth edges* or *Maximum Radio Bandwidth edges*.

For *TAB connectors* supporting operation in *non-contiguous spectrum*, the requirement is also applicable inside a *sub-block gap* for interfering signal offsets where the interfering signal falls completely within the *sub-block gap*. The interfering signal offset is defined relative to the *sub-block edges*.

For *TAB connectors* supporting operation in multiple *operating bands*, the requirement applies relative to the *Base Station RF Bandwidth edges* of each supported *operating band*. In case the *inter RF Bandwidth gap* is less than 15 MHz, the requirement in the gap applies only for interfering signal offsets where the interfering signal falls completely within the *inter RF Bandwidth gap*.

Table 4.3.7.2.3.1-1: Interfering and wanted signals for the co-location transmitter intermodulation requirement

Parameter	Value
Wanted signal	E-UTRA single carrier, or multi-carrier, or multiple intra-band contiguously or non-contiguously aggregated carriers
Interfering signal type	E-UTRA signal of <i>channel bandwidth</i> 5 MHz
Interfering signal power level	<i>Rated total output power per TAB connector</i> in the <i>operating band</i> ($P_{\text{Rated,t,TABC}}$) - 30 dB
Interfering signal centre frequency offset from the lower (upper) edge of the wanted signal or edge of <i>sub-block</i> inside a <i>sub-block gap</i>	$\pm 2,5$ MHz $\pm 7,5$ MHz $\pm 12,5$ MHz
NOTE:	Interfering signal positions that are partially or completely outside of any <i>downlink operating band</i> of the base station are excluded from the requirement, unless the interfering signal positions fall within the frequency range of adjacent <i>downlink operating bands</i> listed in table 1-1.

4.3.7.2.3.2 Intra-system limit

The transmitter intermodulation level shall not exceed the unwanted emission limits in clauses 4.3.2.2.2 (OBUE) and 4.3.4.2 (ACLR) in the presence of a co-channel E-UTRA interfering signal of the same configuration as the wanted signal. The interfering signal shall be incoherent with the wanted signal.

The interfering signal power level at each *TAB connector* is determined as the sum of the co-channel leakage power coupled via the combined RDN and Antenna Array from all the other *TAB connectors*, but does not comprise power radiated from the Antenna Array and reflected back from the environment. The power at each of the interfering *TAB connectors* is $P_{\text{rated,c,TABC}}$.

4.3.7.3 Conformance

The conformance tests for this requirement shall be as defined in clause 5.3.7 of the present document.

4.3.8 Receiver spurious emissions

4.3.8.1 Definition and applicability

The receiver spurious emissions power is the power of emissions generated or amplified in a receiver unit that appear at the *TAB connector*. The requirements apply to all AAS BS with separate RX and TX *TAB connectors*.

The conducted receiver spurious emission limits shall apply from 9 kHz to 12,75 GHz or 5th harmonic of the uplink operating band, excluding the following RAT-specific frequency ranges:

- *MSR operation*: from Δf_{OBUE} below the lowest frequency of the *downlink operating band* up to Δf_{OBUE} above the highest frequency of the *downlink operating band*, where Δf_{OBUE} is defined in table 4.3.2.1-1.
- *Single RAT UTRA operation*: from 12,5 MHz below the *lowest carrier* frequency used up to 12,5 MHz above the *highest carrier* frequency used.
- *Single RAT E-UTRA operation*: from Δf_{OBUE} below the lowest frequency of the *downlink operating band* up to Δf_{OBUE} above the highest frequency of the *downlink operating band*, where Δf_{OBUE} is defined in table 4.3.2.1-1.

NOTE: For bands 7,22, 38, 41, 42, 43, 77 and 78 the upper frequency limit is higher than 12,75 GHz in order to comply with the 5th harmonic limit of the *uplink operating band*, as specified in Recommendation ITU-R SM.329-12 [i.4].

For *TAB connectors* supporting both RX and TX in TDD operation, the requirements apply during the *transmitter OFF period*.

For *TAB connectors* supporting both RX and TX in FDD operation, the receiver spurious requirements are superseded by the TX spurious requirements in clause 4.3.5.

For RX only *multi-band TAB connector(s)*, the RX spurious emissions requirements are subject to exclusion zones in each supported *operating band*.

For *multi-band TAB connector(s)* that both transmit and receive in *operating bands* supporting TDD, RX spurious emissions requirements are applicable during the *transmitter OFF period* and are subject to exclusion zones in each supported *operating band*.

Every *TAB connector* of *Hybrid AAS BS* supporting reception in an *operating band* shall map to one *TAB connector RX min cell group* (D.6.72), where mapping of *TAB connectors* to cells/beams is implementation dependent.

4.3.8.2 Limits

4.3.8.2.1 General limits

For each *TAB connector RX min cell group* the power summation of the emissions at the *TAB connectors of the TAB connector RX min cell group* shall not exceed *limits* specified in table 4.3.8.2.1-1.

In addition to the limits in table 4.3.8.2.1-1, the power of any spurious emission shall not exceed the limits specified in clauses 4.3.5.2.2, 4.3.5.2.3 and 4.3.5.2.4.

Table 4.3.8.2.1-1: General BS receiver spurious emissions limits

Spurious frequency range (note 4)	Limit	Measurement bandwidth	Notes
30 MHz - 1 GHz	-57 dBm	100 kHz	Note 1
1 GHz - 12,75 GHz	-47 dBm	1 MHz	Notes 1, 2
12,75 GHz - 5 th harmonic of the upper frequency edge of the UL <i>operating band</i> in GHz	-47 dBm	1 MHz	Notes 1, 2 and 3
NOTE 1: <i>Measurement bandwidths</i> as in Recommendation ITU-R SM.329-12 [i.4], section 4.1. NOTE 2: Upper frequency as in Recommendation ITU-R SM.329-12 [i.4], section 2.5 table 1. NOTE 3: This spurious frequency range applies only for <i>operating bands</i> for which the 5 th harmonic of the upper frequency edge of the UL <i>operating band</i> is reaching beyond 12,75 GHz. NOTE 4: The frequency range from Δf_{OBUE} below the lowest frequency of the BS transmitter operating band to Δf_{OBUE} above the highest frequency of the BS transmitter <i>operating band</i> , may be excluded from the requirement. Δf_{OBUE} is defined in clause 4.3.2.1. For <i>multi-band TAB connectors</i> , the exclusion applies for all supported <i>operating bands</i> .			

4.3.8.3 Conformance

The conformance tests for this requirement shall be as defined in clause 5.3.8 of the present document.

4.3.9 Blocking

4.3.9.1 Definition and applicability

The out-of-band blocking characteristic is a measure of the receiver ability to receive a wanted signal at its assigned channel in the presence of an unwanted interferer outside the *uplink operating band*.

4.3.9.2 Limits

4.3.9.2.1 Limits for MSR operation

For a wanted and an interfering signal coupled to a *TAB connector* using the parameters in table 4.3.9.2.1-1, the following requirements shall apply:

- For any E-UTRA carrier, the *throughput* shall be ≥ 95 % of the *maximum throughput* of the reference measurement channel specified in clause 4.3.12.2.2.
- For any NR carrier, the *throughput* shall be ≥ 95 % of the *maximum throughput* of the reference measurement channel specified in clause 4.3.12.2.3.

- For any UTRA carrier, the BER shall not exceed 0,001 for the reference measurement channel specified in clause 4.3.12.2.1.

The out-of-band blocking requirement applies from 1 MHz to $F_{UL_low} - \Delta f_{OOB}$ and from $F_{UL_high} + \Delta f_{OOB}$ up to 12 750 MHz, including the downlink frequency range of the FDD *operating band* for BS supporting FDD. The Δf_{OOB} is defined in table 4.3.11.1-1.

The in-band blocking frequency ranges of all supported *operating bands* shall be excluded from the requirement.

Table 4.3.9.2.1-1: Blocking requirement

Wanted Signal mean power [dBm]	Interfering Signal mean power [dBm]	Type of Interfering Signal
$P_{REFSENS} + 6$ dB (note)	-15	CW carrier
NOTE: $P_{REFSENS}$ depends on the RAT, the BS class and the channel bandwidth, see clause 4.3.12.		

4.3.9.2.2 Limits for *single RAT UTRA operation*

The following apply to *TAB connectors* supporting only *single RAT UTRA operation*.

For each UTRA carrier, the BER shall not exceed 0,001 for the parameters specified in tables 4.3.9.2.2-1 to 4.3.9.2.2-6.

The requirement is applicable outside the *Base Station RF Bandwidth* or *Maximum Radio Bandwidth*. The interfering signal offset is defined relative to the lower/upper *Base Station RF Bandwidth edges* or *Maximum Radio Bandwidth edges*.

For a *TAB connector* operating in *non-contiguous spectrum* within any *operating band*, the blocking requirement applies in addition inside any *sub-block gap*, in case the *sub-block gap* size is at least 15 MHz. The interfering signal offset is defined relative to the lower/upper *sub-block* edge inside the *sub-block gap* and is equal to -7,5 MHz/+7,5 MHz, respectively.

For a *TAB connector* operating in *non-contiguous spectrum* within any *operating band*, the narrowband blocking requirements in tables 4.3.9.2.2-4 to 4.3.9.2.2-6 apply in addition inside any *sub-block gap*, in case the *sub-block gap* size is at least 400 kHz or 600 kHz, depending on the *operating band*. The interfering signal offset is defined relative to the lower/upper *sub-block* edge inside the *sub-block gap* and is equal to -200 kHz/+200 kHz or -300 kHz/+300 kHz, respectively.

For a *multi-band TAB connector*, the requirement in the in-band blocking frequency range applies for each supported *operating band*. The requirement applies in addition inside any *Inter RF Bandwidth gap*, in case the *Inter RF Bandwidth gap* size is at least 15 MHz. The interfering signal offset is defined relative to lower/upper *Base Station RF bandwidth edges* inside the *Inter RF Bandwidth gap* and is equal to -7,5 MHz/+7,5 MHz, respectively.

For a *multi-band TAB connector*, the requirement in the out-of-band blocking frequency ranges apply for each *operating band*, with the exception that the in-band blocking frequency ranges of all supported *operating bands* according to tables 4.3.9.2.2-1 to 4.3.9.2.2-3 shall be excluded from the out-of-band blocking requirement.

For a *multi-band TAB connector*, the narrowband blocking requirement applies in addition inside any *Inter RF Bandwidth gap*, in case the *Inter RF Bandwidth gap* size is at least 400 kHz or 600 kHz, depending on the *operating band*. The interfering signal offset is defined relative to lower/upper *Base Station RF Bandwidth edges* inside the *Inter RF Bandwidth gap* and is equal to -200 kHz/+200 kHz or -300 kHz/+300 kHz, respectively.

Table 4.3.9.2.2-1: Blocking characteristics for Wide Area BS

Operating Band	Centre Frequency of Interfering Signal	Interfering Signal mean power	Wanted Signal mean power	Minimum Offset of Interfering Signal	Type of Interfering Signal
I	1 920 MHz - 1 980 MHz	-40 dBm	-115 dBm	±10 MHz	WCDMA signal (note 1)
	1 900 MHz - 1 920 MHz	-40 dBm	-115 dBm	±10 MHz	WCDMA signal (note 1)
	1 980 MHz - 2 000 MHz	-40 dBm	-115 dBm	—	—
	1 MHz - 1 900 MHz 2 000 MHz - 12 750 MHz	-15 dBm	-115 dBm	—	CW carrier

Operating Band	Centre Frequency of Interfering Signal	Interfering Signal mean power	Wanted Signal mean power	Minimum Offset of Interfering Signal	Type of Interfering Signal
III	1 710 MHz - 1 785 MHz	-40 dBm	-115 dBm	±10 MHz	WCDMA signal (note 1)
	1 690 MHz - 1 710 MHz 1 785 MHz - 1 805 MHz	-40 dBm	-115 dBm	±10 MHz	WCDMA signal (note 1)
	1 MHz - 1 690 MHz 1 805 MHz - 12 750 MHz	-15 dBm	-115 dBm	—	CW carrier
VIII	880 MHz - 915 MHz	-40 dBm	-115 dBm	±10 MHz	WCDMA signal (note 1)
	860 MHz - 880 MHz 915 MHz - 925 MHz	-40 dBm	-115 dBm	±10 MHz	WCDMA signal (note 1)
	1 MHz - 860 MHz 925 MHz - 12 750 MHz	-15 dBm	-115 dBm	—	CW carrier
XX	832 MHz - 862 MHz	-40 dBm	-115 dBm	±10 MHz	WCDMA signal (note 1)
	821 MHz - 832 MHz 862 MHz - 882 MHz	-40 dBm	-115 dBm	±10 MHz	WCDMA signal (note 1)
	1 MHz - 821 MHz 882 MHz - 12 750 MHz	-15 dBm	-115 dBm	—	CW carrier
XXII	3 410 MHz - 3 490 MHz	-40 dBm	-115 dBm	±10 MHz	WCDMA signal (note 1)
	3 390 MHz - 3 410 MHz 3 490 MHz - 3 510 MHz	-40 dBm	-115 dBm	±10 MHz	WCDMA signal (note 1)
	1 MHz - 3 390 MHz 3 510 MHz - 12 750 MHz	-15 dBm	-115 dBm	—	CW carrier

NOTE 1: The characteristics of the WCDMA interfering signal are specified in annex I of ETSI TS 125 141 [7].

NOTE 2: For a *multi-band TAB connector*, in case of interfering signal that is not in the in-band blocking frequency range of the *operating band* where the wanted signal is present, or in the in-band blocking frequency range of an adjacent or overlapping operating band, the wanted signal mean power is equal to -119,6 dBm.

Table 4.3.9.2.2-2: Blocking characteristics for Medium Range BS

Operating Band	Centre Frequency of Interfering Signal	Interfering Signal Level	Wanted Signal mean power	Minimum Offset of Interfering Signal	Type of Interfering Signal
I	1 920 MHz - 1 980 MHz	-35 dBm	-105 dBm	±10 MHz	WCDMA signal (note 1)
	1 900 MHz - 1 920 MHz 1 980 MHz - 2 000 MHz	-35 dBm	-105 dBm	±10 MHz	WCDMA signal (note 1)
	1 MHz - 1 900 MHz 2 000 MHz - 12 750 MHz	-15 dBm	-105 dBm	—	CW carrier
III	1 710 MHz - 1 785 MHz	-35 dBm	-105 dBm	±10 MHz	WCDMA signal (note 1)
	1 690 MHz - 1 710 MHz 1 785 MHz - 1 805 MHz	-35 dBm	-105 dBm	±10 MHz	WCDMA signal (note 1)
	1 MHz - 1 690 MHz 1 805 MHz - 12 750 MHz	-15 dBm	-105 dBm	—	CW carrier
VII	2 500 MHz - 2 570 MHz	-35 dBm	-105 dBm	±10 MHz	WCDMA signal (note 1)
	2 480 MHz - 2 500 MHz 2 570 MHz - 2 590 MHz	-35 dBm	-105 dBm	±10 MHz	WCDMA signal (note 1)
	1 MHz - 2 480 MHz 2 590 MHz - 12 750 MHz	-15 dBm	-105 dBm	—	CW carrier
VIII	880 MHz - 915 MHz	-35 dBm	-105 dBm	±10 MHz	WCDMA signal (note 1)
	860 MHz - 880 MHz 915 MHz - 925 MHz	-35 dBm	-105 dBm	±10 MHz	WCDMA signal (note 1)
	1 MHz - 860 MHz 925 MHz - 12 750 MHz	-15 dBm	-105 dBm	—	CW carrier
XX	832 MHz - 862 MHz	-35 dBm	-105 dBm	±10 MHz	WCDMA signal (note 1)
	821 MHz - 832 MHz 862 MHz - 882 MHz	-35 dBm	-105 dBm	±10 MHz	WCDMA signal (note 1)
	1 MHz - 821 MHz 882 MHz - 12 750 MHz	-15 dBm	-105 dBm	—	CW carrier
XXII	3 410 MHz - 3 490 MHz	-35 dBm	-105 dBm	±10 MHz	WCDMA signal (note 1)
	3 390 MHz - 3 410 MHz 3 490 MHz - 3 510 MHz	-35 dBm	-105 dBm	±10 MHz	WCDMA signal (note 1)
	1 MHz - 3 390 MHz 3 510 MHz - 12 750 MHz	-15 dBm	-105 dBm	—	CW carrier

Operating Band	Centre Frequency of Interfering Signal	Interfering Signal Level	Wanted Signal mean power	Minimum Offset of Interfering Signal	Type of Interfering Signal
NOTE 1: The characteristics of the WCDMA interfering signal are specified in annex I of ETSI TS 125 141 [7].					
NOTE 2: For a <i>multi-band TAB connector</i> , in case of interfering signal that is not in the in-band blocking frequency range of the <i>operating band</i> where the wanted signal is present, or in the in-band blocking frequency range of an adjacent or overlapping operating band, the wanted signal mean power is equal to -109,6 dBm.					

Table 4.3.9.2.2-3: Blocking characteristics for Local Area

Operating Band	Centre Frequency of Interfering Signal	Interfering Signal Level	Wanted Signal mean power	Minimum Offset of Interfering Signal	Type of Interfering Signal
I	1 920 MHz - 1 980 MHz	-30 dBm	-101 dBm	± 10 MHz	WCDMA signal (note 1)
	1 900 MHz - 1 920 MHz	-30 dBm	-101 dBm	± 10 MHz	WCDMA signal (note 1)
	1 980 MHz - 2 000 MHz	-30 dBm	-101 dBm	± 10 MHz	WCDMA signal (note 1)
	1 MHz - 1 900 MHz 2 000 MHz - 12 750 MHz	-15 dBm	-101 dBm	–	CW carrier
III	1 710 MHz - 1 785 MHz	-30 dBm	-101 dBm	± 10 MHz	WCDMA signal (note 1)
	1 690 MHz - 1 710 MHz	-30 dBm	-101 dBm	± 10 MHz	WCDMA signal (note 1)
	1 785 MHz - 1 805 MHz	-30 dBm	-101 dBm	± 10 MHz	WCDMA signal (note 1)
	1 MHz - 1 690 MHz 1 805 MHz - 12 750 MHz	-15 dBm	-101 dBm	–	CW carrier
VII	2 500 MHz - 2 570 MHz	-30 dBm	-101 dBm	± 10 MHz	WCDMA signal (note 1)
	2 480 MHz - 2 500 MHz	-30 dBm	-101 dBm	± 10 MHz	WCDMA signal (note 1)
	2 570 MHz - 2 590 MHz	-30 dBm	-101 dBm	± 10 MHz	WCDMA signal (note 1)
	1 MHz - 2 480 MHz 2 590 MHz - 12 750 MHz	-15 dBm	-101 dBm	–	CW carrier
VIII	880 MHz - 915 MHz	-30 dBm	-101 dBm	± 10 MHz	WCDMA signal (note 1)
	860 MHz - 880 MHz	-30 dBm	-101 dBm	± 10 MHz	WCDMA signal (note 1)
	915 MHz - 925 MHz	-30 dBm	-101 dBm	± 10 MHz	WCDMA signal (note 1)
	1 MHz - 860 MHz 925 MHz - 12 750 MHz	-15 dBm	-101 dBm	–	CW carrier
XX	832 MHz - 862 MHz	-30 dBm	-101 dBm	± 10 MHz	WCDMA signal (note 1)
	821 MHz - 832 MHz	-30 dBm	-101 dBm	± 10 MHz	WCDMA signal (note 1)
	862 MHz - 882 MHz	-30 dBm	-101 dBm	± 10 MHz	WCDMA signal (note 1)
	1 MHz - 821 MHz 882 MHz - 12 750 MHz	-15 dBm	-101 dBm	–	CW carrier
XXII	3 410 MHz - 3 490 MHz	-30 dBm	-101 dBm	± 10 MHz	WCDMA signal (note 1)
	3 390 MHz - 3 410 MHz	-30 dBm	-101 dBm	± 10 MHz	WCDMA signal (note 1)
	3 490 MHz - 3 510 MHz	-30 dBm	-101 dBm	± 10 MHz	WCDMA signal (note 1)
	1 MHz - 3 390 MHz 3 510 MHz - 12 750 MHz	-15 dBm	-101 dBm	–	CW carrier
NOTE 1: The characteristics of the WCDMA interfering signal are specified in annex I of ETSI TS 125 141 [7].					
NOTE 2: For a <i>multi-band TAB connector</i> , in case of interfering signal that is not in the in-band blocking frequency range of the <i>operating band</i> where the wanted signal is present, or in the in-band blocking frequency range of an adjacent or overlapping operating band, the wanted signal mean power is equal to -105,6 dBm.					

Table 4.3.9.2.2-4: Blocking requirement (narrowband) for Wide Area BS

Operating Band	Centre Frequency of Interfering Signal	Interfering Signal mean power	Wanted Signal mean power	Minimum Offset of Interfering Signal	Type of Interfering Signal (note)
III	1 710 MHz - 1 785 MHz	- 47 dBm	-115 dBm	$\pm 2,8$ MHz	GMSK modulated
VIII	880 MHz - 915 MHz	- 47 dBm	-115 dBm	$\pm 2,8$ MHz	GMSK modulated
NOTE: GMSK modulation as defined in ETSI TS 145 004 [8].					

Table 4.3.9.2.2-5: Blocking requirement (narrowband) for Medium range BS

Operating Band	Centre Frequency of Interfering Signal	Interfering Signal mean power	Wanted Signal mean power	Minimum Offset of Interfering Signal	Type of Interfering Signal
III	1 710 MHz - 1 785 MHz	- 42 dBm	-105 dBm	±2,8 MHz	GMSK modulated
VIII	880 MHz - 915 MHz	- 42 dBm	-105 dBm	±2,8 MHz	GMSK modulated

NOTE: GMSK modulation as defined in ETSI TS 145 004 [8].

Table 4.3.9.2.2-6: Blocking requirement (narrowband) for Local Area

Operating Band	Centre Frequency of Interfering Signal	Interfering Signal mean power	Wanted Signal mean power	Minimum Offset of Interfering Signal	Type of Interfering Signal
III	1 710 MHz - 1 785 MHz	- 37 dBm	-101 dBm	±2,8 MHz	GMSK modulated
VIII	880 MHz - 915 MHz	- 37 dBm	-101 dBm	±2,8 MHz	GMSK modulated

NOTE: GMSK modulation as defined in ETSI TS 145 004 [8].

4.3.9.2.3 Limits for *single RAT E-UTRA operation*

The following apply to *TAB connectors* supporting only *single RAT E-UTRA operation*.

For each E-UTRA carrier, the *throughput* shall be ≥ 95 % of the *maximum throughput* of the reference measurement channel, with a wanted and an interfering signal coupled to BS antenna input using the parameters in tables 4.3.9.2.3-1 to 4.3.9.2.3-4. The reference measurement channel for the wanted signal is specified in clause 4.3.12.2.2 for each *channel bandwidth* and *BS class*.

The blocking requirement is always applicable outside the *Base Station RF Bandwidth* or *Maximum Radio Bandwidth*. The interfering signal offset is defined relative to the *Base Station RF Bandwidth edges* or *Maximum Radio Bandwidth edges*.

For a *TAB connector* operating in *non-contiguous spectrum* within any *operating band*, the blocking requirement applies in addition inside any *sub-block gap*, in case the *sub-block gap* size is at least as wide as twice the interfering signal minimum offset in table 4.3.9.2.3-4. The interfering signal offset is defined relative to the *sub-block* edges inside the *sub-block gap*.

For a *multi-band TAB connector*, the requirement in the in-band blocking frequency ranges applies for each supported *operating band*. The requirement applies in addition inside any *Inter RF Bandwidth gap*, in case the *Inter RF Bandwidth gap* size is at least as wide as twice the interfering signal minimum offset in table 4.3.9.2.3-4.

For a *multi-band TAB connector*, the requirement in the out-of-band blocking frequency ranges apply for each *operating band*, with the exception that the in-band blocking frequency ranges of all supported *operating bands* according to tables 4.3.9.2.3-1, 4.3.9.2.3-2 and 4.3.9.2.3-3 shall be excluded from the out-of-band blocking requirement.

Table 4.3.9.2.3-1: Blocking requirement for Wide Area BS

Operating Band	Centre Frequency of Interfering Signal (MHz)	Interfering Signal mean power (dBm)	Wanted Signal mean power (dBm) (note 1)	Interfering signal centre frequency minimum frequency offset from the lower/upper <i>Base Station RF Bandwidth edge</i> or <i>sub-block edge</i> inside a <i>sub-block gap</i> (MHz)	Type of Interfering Signal
1, 3, 7, 22, 33, 38, 40, 42, 43, 50, 65, 68	(F _{UL_low} -20) to (F _{UL_high} +20)	-43	P _{REFSENS} +6 dB (note 2)	See table 4.3.9.2.3-4	See table 4.3.9.2.3-4
	1 (F _{UL_high} +20) to 12 750 (F _{UL_low} -20)	-15	P _{REFSENS} +6 dB	–	CW carrier

Operating Band	Centre Frequency of Interfering Signal (MHz)	Interfering Signal mean power (dBm)	Wanted Signal mean power (dBm) (note 1)	Interfering signal centre frequency minimum frequency offset from the lower/upper Base Station RF Bandwidth edge or sub-block edge inside a sub-block gap (MHz)	Type of Interfering Signal
8, 28	(F _{UL_low} -20) to (F _{UL_high} +10)	-43	P _{PREFSENS} +6 dB (note 2)	See table 4.3.9.2.3-4	See table 4.3.9.2.3-4
	1 to (F _{UL_low} -20) (F _{UL_high} +10) to 12 750	-15	P _{PREFSENS} +6 dB	–	CW carrier
20	(F _{UL_low} -11) to (F _{UL_high} +20)	-43	P _{PREFSENS} +6 dB (note 2)	See table 4.3.9.2.3-4	See table 4.3.9.2.3-4
	1 to (F _{UL_low} -11) (F _{UL_high} +20) to 12 750	-15	P _{PREFSENS} +6 dB	–	CW carrier
31, 72	(F _{UL_low} -20) to (F _{UL_high} +5)	-43	P _{PREFSENS} +6 dB (note 2)	See table 4.3.9.2.3-4	See table 4.3.9.2.3-4
	1 to (F _{UL_low} -20) (F _{UL_high} +5) to 12 750	-15	P _{PREFSENS} +6 dB	–	CW carrier

NOTE 1: P_{PREFSENS} depends on the *channel bandwidth* as specified in clause 4.3.12.
NOTE 2: For a *multi-band TAB connector*, in case of interfering signal that is not in the in-band blocking frequency range of the *operating band* where the wanted signal is present, or in the in-band blocking frequency range of an adjacent or overlapping operating band, the wanted signal mean power is equal to P_{PREFSENS} + 1,4 dB.

Table 4.3.9.2.3-2: Blocking requirement for Medium Range BS

Operating Band	Centre Frequency of Interfering Signal (MHz)	Interfering Signal mean power (dBm)	Wanted Signal mean power (dBm) (note 1)	Interfering signal centre frequency minimum frequency offset to the lower/upper Base Station RF Bandwidth edge or sub-block edge inside a sub-block gap (MHz)	Type of Interfering Signal
1, 3, 7, 22, 33, 38, 40, 42, 43, 50, 65, 68	(F _{UL_low} -20) to (F _{UL_high} +20)	-38	P _{PREFSENS} +6 dB (note 2)	See table 4.3.9.2.3-4	See table 4.3.9.2.3-4
	1 to (F _{UL_low} -20) (F _{UL_high} +20) to 12 750	-15	P _{PREFSENS} +6 dB	–	CW carrier
8, 28	(F _{UL_low} -20) to (F _{UL_high} +10)	-38	P _{PREFSENS} +6 dB (note 2)	See table 4.3.9.2.3-4	See table 4.3.9.2.3-4
	1 to (F _{UL_low} -20) (F _{UL_high} +10) to 12 750	-15	P _{PREFSENS} +6 dB	–	CW carrier
20	(F _{UL_low} -11) to (F _{UL_high} +20)	-38	P _{PREFSENS} +6 dB (note 2)	See table 4.3.9.2.3-4	See table 4.3.9.2.3-4
	1 to (F _{UL_low} -11) (F _{UL_high} +20) to 12 750	-15	P _{PREFSENS} +6 dB	–	CW carrier
31, 72	(F _{UL_low} -20) to (F _{UL_high} +5)	-38	P _{PREFSENS} +6 dB (note 2)	See table 4.3.9.2.3-4	See table 4.3.9.2.3-4
	1 to (F _{UL_low} -20) (F _{UL_high} +5) to 12 750	-15	P _{PREFSENS} +6 dB	–	CW carrier

NOTE 1: P_{PREFSENS} depends on the *channel bandwidth* as specified in clause 4.3.12.
NOTE 2: For a *multi-band TAB connector*, in case of interfering signal that is not in the in-band blocking frequency range of the *operating band* where the wanted signal is present, or in the in-band blocking frequency range of an adjacent or overlapping operating band, the wanted signal mean power is equal to P_{PREFSENS} + 1,4 dB.

Table 4.3.9.2.3-3: Blocking requirement for Local Area BS

Operating Band	Centre Frequency of Interfering Signal (MHz)	Interfering Signal mean power (dBm)	Wanted Signal mean power (dBm) (note 1)	Interfering signal centre frequency minimum frequency offset from the lower/upper Base Station RF Bandwidth edge or sub-block edge inside a sub-block gap (MHz)	Type of Interfering Signal
1, 3, 7, 22, 33, 38, 40, 42, 43, 50, 65, 68	(F _{UL_low} -20) to (F _{UL_high} +20)	-35	P _{REFSENS} +6 dB (note 2)	See table 4.3.9.2.3-4	See table 4.3.9.2.3-4
	1 (F _{UL_high} +20) to (F _{UL_low} -20) to 12 750	-15	P _{REFSENS} +6 dB	–	CW carrier
8, 28	(F _{UL_low} -20) to (F _{UL_high} +10)	-35	P _{REFSENS} +6 dB (note 2)	See table 4.3.9.2.3-4	See table 4.3.9.2.3-4
	1 (F _{UL_high} +10) to (F _{UL_low} -20) to 12 750	-15	P _{REFSENS} +6 dB	–	CW carrier
20	(F _{UL_low} -11) to (F _{UL_high} +20)	-35	P _{REFSENS} +6 dB (note 2)	See table 4.3.9.2.3-4	See table 4.3.9.2.3-4
	1 (F _{UL_high} +20) to (F _{UL_low} -11) to 12 750	-15	P _{REFSENS} +6 dB	–	CW carrier
31, 72	(F _{UL_low} -20) to (F _{UL_high} +5)	-35	P _{REFSENS} +6 dB (note 2)	See table 4.3.9.2.3-4	See table 4.3.9.2.3-4
	1 (F _{UL_high} +5) to (F _{UL_low} -20) to 12 750	-15	P _{REFSENS} +6 dB	–	CW carrier

NOTE 1: P_{REFSENS} depends on the *channel bandwidth* as specified in clause 4.3.12.
NOTE 2: For a *multi-band TAB connector*, in case of interfering signal that is not in the in-band blocking frequency range of the *operating band* where the wanted signal is present, or in the in-band blocking frequency range of an adjacent or overlapping operating band, the wanted signal mean power is equal to P_{REFSENS} + 1,4 dB.

Table 4.3.9.2.3-4: Interfering signals for blocking requirement

E-UTRA channel BW of the lowest/highest carrier received (MHz)	Interfering signal centre frequency minimum offset to the lower/upper Base Station RF Bandwidth edge or sub-block edge inside a sub-block gap (MHz)	Type of interfering signal
1,4	±2,1	1,4 MHz E-UTRA signal
3	±4,5	3 MHz E-UTRA signal
5	±7,5	5 MHz E-UTRA signal
10	±7,5	5 MHz E-UTRA signal
15	±7,5	5 MHz E-UTRA signal
20	±7,5	5 MHz E-UTRA signal

4.3.9.3 Conformance

The conformance tests for this requirement shall be as defined in clause 5.3.9 of the present document.

4.3.10 Receiver intermodulation

4.3.10.1 Definition and applicability

Third and higher order mixing of the two interfering RF signals can produce an interfering signal in the band of the desired channel. Intermodulation response rejection is a measure of the capability of the receiver unit to receive a wanted signal on its assigned channel frequency in the presence of two interfering signals which have a specific frequency relationship to the wanted signal. The requirement applies per *TAB connector*.

4.3.10.2 Limits

4.3.10.2.1 Limits for *MSR operation*

4.3.10.2.1.1 General intermodulation requirement

Interfering signals shall be a CW signal and an E-UTRA or UTRA signal, as specified in annex A of ETSI TS 137 141 [6].

The requirement is applicable outside the *Base Station RF Bandwidth* or *Maximum Radio Bandwidth*. The interfering signal offset is defined relative to the *Base Station RF Bandwidth edges* or *Maximum Radio Bandwidth edges*.

For *multi-band TAB connectors*, the requirement applies in addition inside any *Inter RF Bandwidth gap* at those connectors, in case the gap size is at least twice as wide as the UTRA/E-UTRA interfering signal centre frequency offset from the *Base Station RF Bandwidth edge*. The interfering signal offset is defined relative to the *Base Station RF Bandwidth edges* inside the *Inter RF Bandwidth gap*.

For the wanted signal at the assigned channel frequency and two interfering signals coupled to the *TAB connector*, using the parameters in tables 4.3.10.2.1.1-1 and 4.3.10.2.1.1-2 the following requirements shall apply:

- For any UTRA FDD carrier, the BER shall not exceed 0,001 for the reference measurement channel specified in clause 4.3.12.2.1.
- For any E-UTRA carrier, the *throughput* shall be ≥ 95 % of the *maximum throughput* of the reference measurement channel specified in clause 4.3.12.2.2.
- For any NR carrier, the *throughput* shall be ≥ 95 % of the *maximum throughput* of the reference measurement channel specified in clause 4.3.12.2.3.

Table 4.3.10.2.1.1-1: General intermodulation requirement

Base Station Type	Mean power of interfering signals [dBm]	Wanted Signal mean power [dBm]	Type of interfering signal
Wide Area BS	-48 + y (note 6)	$P_{\text{REFSENS}} + x$ dB (notes 2 and 5)	See table 4.3.10.2.1.1-2
Medium Range BS	-44 + y (note 6)	$P_{\text{REFSENS}} + x$ dB (notes 3 and 5)	
Local Area BS	-38 + y (note 6)	$P_{\text{REFSENS}} + x$ dB (notes 4 and 5)	
NOTE 1: P_{REFSENS} depends on the RAT, the BS class and on the <i>channel bandwidth</i> , see clause 4.3.12.2.			
NOTE 2: For <i>Wide Area BS</i> not supporting NR, "x" is equal to 6 in case of E-UTRA or UTRA wanted signals.			
NOTE 3: For <i>Medium Range BS</i> not supporting NR, "x" is equal to 6 in case of UTRA wanted signals, 9 in case of E-UTRA wanted signal.			
NOTE 4: For <i>Local Area BS</i> not supporting NR, "x" is equal to 12 in case of E-UTRA wanted signals, 6 in case of UTRA wanted signal.			
NOTE 5: For a BS supporting NR and not supporting UTRA, x is equal to 6.			
NOTE 6: For a BS not supporting NR, "y" is equal to zero for all BS classes. For a BS that supports NR and not supporting UTRA; "y" is equal to -4 for the <i>Wide Area BS</i> , -3 for the <i>Medium Range BS</i> and -6 for the <i>Local Area BS</i> .			

Table 4.3.10.2.1.1-2: Interfering signals for intermodulation requirement

RAT of the carrier adjacent to the upper/lower <i>Base Station RF Bandwidth edge</i>	Interfering signal centre frequency offset from the <i>Base Station RF Bandwidth edge</i> [MHz]	Type of interfering signal
E-UTRA 1,4 MHz	$\pm 2,0$ (BC1 and BC3) / $\pm 2,1$ (BC2)	CW
	$\pm 4,9$	1,4 MHz E-UTRA signal
E-UTRA 3 MHz	$\pm 4,4$ (BC1 and BC3) / $\pm 4,5$ (BC2)	CW
	$\pm 10,5$	3 MHz E-UTRA signal
UTRA FDD and E-UTRA 5 MHz	$\pm 7,5$	CW
	$\pm 17,5$	5 MHz E-UTRA signal
E-UTRA 10 MHz	$\pm 7,375$	CW
	$\pm 17,5$	5 MHz E-UTRA signal
E-UTRA 15 MHz	$\pm 7,25$	CW
	$\pm 17,5$	5 MHz E-UTRA signal

RAT of the carrier adjacent to the upper/lower <i>Base Station RF Bandwidth edge</i>	Interfering signal centre frequency offset from the <i>Base Station RF Bandwidth edge</i> [MHz]	Type of interfering signal
E-UTRA 20 MHz	±7,125	CW
	±17,5	5 MHz E-UTRA signal
NR 5 MHz	±7,5	CW
	±17,5	5 MHz E-UTRA signal
NR 10 MHz	±7,465	CW
	±17,5	5 MHz E-UTRA signal
NR 15 MHz	±7,43	CW
	±17,5	5 MHz E-UTRA signal
NR 20 MHz	±7,395	CW
	±17,5	5 MHz E-UTRA signal
NR 25 MHz	±7,465	CW
	±25	20 MHz E-UTRA signal
NR 30 MHz	±7,43	CW
	±25	20 MHz E-UTRA signal
NR 40 MHz	±7,45	CW
	±25	20 MHz E-UTRA signal
NR 50 MHz	±7,35	CW
	±25	20 MHz E-UTRA signal
NR 60 MHz	±7,49	CW
	±25	20 MHz E-UTRA signal
NR 70 MHz	±7,42	CW
	±25	20 MHz E-UTRA signal
NR 80 MHz	±7,44	CW
	±25	20 MHz E-UTRA signal
NR 90 MHz	±7,46	CW
	±25	20 MHz E-UTRA signal
NR 100 MHz	±7,48	CW
	±25	20 MHz E-UTRA signal

4.3.10.2.1.2 General narrowband intermodulation requirement

Interfering signals shall be a CW signal and an E-UTRA 1RB signal, as specified in annex A of ETSI TS 137 141 [6].

The requirement is applicable outside the *Base Station RF Bandwidth* or *Maximum Radio Bandwidth*. The interfering signal offset is defined relative to the *Base Station RF bandwidth edges* or *Maximum Radio Bandwidth edges*.

For a *TAB connector* operating in *non-contiguous spectrum* within each supported *operating band*, the requirement applies in addition inside any *sub-block gap* in case the *sub-block gap* is at least as wide as the *channel bandwidth* of the E-UTRA interfering signal in table 4.3.10.2.1.2-2. The interfering signal offset is defined relative to the *sub-block edges* inside the gap.

For a *multi-band TAB connector*, the requirement applies in addition inside any *Inter RF Bandwidth gap* in case the gap size is at least as wide as the E-UTRA interfering signal in table 4.3.10.2.1.2-2. The interfering signal offset is defined relative to the *Base station RF bandwidth edges* inside the *Inter RF Bandwidth gap*.

For the wanted signal at the assigned channel frequency and two interfering signals coupled to the Base Station antenna input, using the parameters in tables 4.3.10.2.1.2-1 and 4.3.10.2.1.2-2, the following requirements shall apply:

- For any UTRA FDD carrier, the BER shall not exceed 0,001 for the reference measurement channel specified in clause 4.3.12.2.1.
- For any E-UTRA carrier, the *throughput* shall be ≥ 95 % of the *maximum throughput* of the reference measurement channel specified in clause 4.3.12.2.2.
- For any NR carrier, the *throughput* shall be ≥ 95 % of the *maximum throughput* of the reference measurement channel specified in clause 4.3.12.2.3.

Table 4.3.10.2.1.2-1: General narrowband intermodulation requirement

Base Station Type	Mean power of interfering signals (dBm)	Wanted Signal mean power (dBm)	Type of interfering signal
Wide Area BS	-52	$P_{\text{PREFSENS}} + X$ dB (see note)	See table 4.3.10.2.1.2-2
Medium Range BS	-47		
Local Area BS	-44		
NOTE: P_{PREFSENS} depends on the RAT, the BS class and on the channel bandwidth, see clause 4.3.12.2. "x" is equal to 6 dB in case of E-UTRA or UTRA or NR wanted signals.			

Table 4.3.10.2.1.2-2: Interfering signals for narrowband intermodulation requirement

RAT of the carrier adjacent to the upper/lower Base Station RF Bandwidth edge or edge of the sub-block	CW or 1RB interfering signal centre frequency offset from the Base Station RF Bandwidth edge or edge of sub-block inside a gap (kHz)	Type of interfering signal
E-UTRA 1,4 MHz	± 260 (BC1 and BC3) / ± 270 (BC2)	CW
	± 970 (BC1 and BC3) / ± 790 (BC2)	1,4 MHz E-UTRA signal, 1 RB (note 1)
E-UTRA 3 MHz	± 260 (BC1 and BC3) / ± 270 (BC2)	CW
	± 960 (BC1 and BC3) / ± 780 (BC2)	3,0 MHz E-UTRA signal, 1 RB (note 1)
E-UTRA 5 MHz	± 360 $\pm 1\ 060$	CW 5 MHz E-UTRA signal, 1 RB (note 1)
E-UTRA 10 MHz (note 2)	± 325 $\pm 1\ 240$	CW 5 MHz E-UTRA signal, 1 RB (note 1)
E-UTRA 15 MHz (note 2)	± 380 $\pm 1\ 600$	CW 5 MHz E-UTRA signal, 1 RB (note 1)
E-UTRA 20 MHz (note 2)	± 345 $\pm 1\ 780$	CW 5 MHz E-UTRA signal, 1 RB (note 1)
UTRA FDD	± 345 (BC1 and BC2)	CW
	$\pm 1\ 780$ (BC1 and BC2)	5 MHz E-UTRA signal, 1 RB (note 1)
NR 5 MHz	± 360 $\pm 1\ 420$	CW E-UTRA signal, 1 RB (note 1)
	± 370 $\pm 1\ 960$	CW E-UTRA signal, 1 RB (note 1)
NR 10 MHz	± 380 $\pm 1\ 960$	CW E-UTRA signal, 1 RB (note 1)
	± 390 $\pm 2\ 320$	CW E-UTRA signal, 1 RB (note 1)
NR 15 MHz (note 2)	± 325 $\pm 2\ 350$	CW E-UTRA signal, 1 RB (note 1)
	± 335 $\pm 2\ 350$	CW E-UTRA signal, 1 RB (note 1)
NR 20 MHz (note 2)	± 355 $\pm 2\ 710$	CW E-UTRA signal, 1 RB (note 1)
	± 375 $\pm 2\ 710$	CW E-UTRA signal, 1 RB (note 1)
NR 25 MHz (note 2)	± 395 $\pm 2\ 710$	CW E-UTRA signal, 1 RB (note 1)
	± 415 $\pm 2\ 710$	CW E-UTRA signal, 1 RB (note 1)
NR 30 MHz (note 2)	± 435 $\pm 2\ 710$	CW E-UTRA signal, 1 RB (note 1)
	± 365 $\pm 2\ 530$	CW E-UTRA signal, 1 RB (note 1)
NR 40 MHz (note 2)	± 365 $\pm 2\ 530$	CW E-UTRA signal, 1 RB (note 1)
	± 375 $\pm 2\ 710$	CW E-UTRA signal, 1 RB (note 1)
NR 50 MHz (note 2)	± 395 $\pm 2\ 710$	CW E-UTRA signal, 1 RB (note 1)
	± 415 $\pm 2\ 710$	CW E-UTRA signal, 1 RB (note 1)
NR 60 MHz (note 2)	± 435 $\pm 2\ 710$	CW E-UTRA signal, 1 RB (note 1)
	± 365 $\pm 2\ 530$	CW E-UTRA signal, 1 RB (note 1)
NR 70 MHz (note 2)	± 365 $\pm 2\ 530$	CW E-UTRA signal, 1 RB (note 1)
	± 375 $\pm 2\ 710$	CW E-UTRA signal, 1 RB (note 1)
NR 80 MHz (note 2)	± 395 $\pm 2\ 710$	CW E-UTRA signal, 1 RB (note 1)
	± 415 $\pm 2\ 710$	CW E-UTRA signal, 1 RB (note 1)
NR 90 MHz (note 2)	± 435 $\pm 2\ 710$	CW E-UTRA signal, 1 RB (note 1)
	± 365 $\pm 2\ 530$	CW E-UTRA signal, 1 RB (note 1)

RAT of the carrier adjacent to the upper/lower Base Station RF Bandwidth edge or edge of the sub-block	CW or 1RB interfering signal centre frequency offset from the Base Station RF Bandwidth edge or edge of sub-block inside a gap (kHz)	Type of interfering signal
NR 100 MHz (note 2)	±385	CW
	±2 530	E-UTRA signal, 1 RB (note 1)
NOTE 1: Interfering signal consisting of one resource block positioned at the stated offset, the <i>channel bandwidth</i> of the interfering signal is located adjacently to the <i>Base Station RF Bandwidth edge</i> .		
NOTE 2: This requirement shall apply only for an E-UTRA FRC A1-3 mapped to the frequency range at the <i>channel edge</i> adjacent to the interfering signals.		

4.3.10.2.2 Limits for single RAT UTRA operation

The following apply to *TAB connectors* supporting only *single RAT UTRA operation*.

For each measured carrier, the BER shall not exceed 0,001 for the parameters specified in tables 4.3.10.2.2-1 and 4.3.10.2.2-2.

For a *TAB connector* operating in *non-contiguous spectrum* within any *operating band*, the narrowband intermodulation requirement applies in addition inside any *sub-block gap*, in case the *sub-block gap* size is at least 6,8 MHz. The CW interfering signal offset is defined relative to the lower/upper *sub-block* edge inside the *sub-block gap* and is equal to -1 MHz/+1 MHz, respectively. The GMSK modulated interfering signal offset is defined relative to the lower/upper *sub-block* edge inside the *sub-block gap* and is equal to -3,4 MHz/+3,4 MHz, respectively. The requirement applies separately for both *sub-blocks*.

For a *multi-band TAB connector*, the narrowband intermodulation requirement applies in addition inside any *Inter RF Bandwidth gap*, in case the *Inter RF Bandwidth gap* size is at least 6,8 MHz. The CW interfering signal offset is defined relative to lower/upper *Base Station RF Bandwidth edges* inside the *Inter RF Bandwidth gap* and is equal to -1 MHz/+1 MHz, respectively. The GMSK modulated interfering signal offset is defined relative to lower/upper *Base Station RF Bandwidth edges* inside the *Inter RF Bandwidth gap* and is equal to -3,4 MHz/+3,4 MHz, respectively.

Table 4.3.10.2.2-1: UTRA intermodulation requirement

Operating Band	Type of Signal	Offset	Signal mean power		
			Wide Area BS	Medium Range BS	Local Area
All bands	Wanted signal	-	-115 dBm	-105 dBm	-101 dBm
	CW signal	±10 MHz	-48 dBm	-44 dBm	-38 dBm
	WCDMA signal (note)	±20 MHz	-48 dBm	-44 dBm	-38 dBm
NOTE: The characteristics of the WCDMA interfering signal are specified in annex I of ETSI TS 125 141 [7].					

Table 4.3.10.2.2-2: UTRA narrowband intermodulation requirement

Operating band	Type of Signal	Offset	Signal mean power		
			Wide Area BS	Medium Range BS	Local Area
III, VII	Wanted signal	-	-115 dBm	-105 dBm	-101 dBm
	CW signal	±3,5 MHz	- 47 dBm	- 43 dBm	-37 dBm
	GMSK modulated (note)	±5,9 MHz	- 47 dBm	- 43 dBm	-37 dBm
NOTE: GMSK as defined in ETSI TS 145 004 [8].					

4.3.10.2.3 Limits for single RAT E-UTRA operation

The following apply to *TAB connectors* supporting only *single RAT E-UTRA operation*.

For each E-UTRA carrier, the *throughput* shall be $\geq 95\%$ of the *maximum throughput* of the reference measurement channel, with a wanted signal at the assigned channel frequency and two interfering signals with the conditions specified in tables 4.3.10.2.3-1 and 4.3.10.2.3-2 for intermodulation performance and in tables 4.3.10.2.3-3, 4.3.10.2.3-4 and 4.3.10.2.3-5 for narrowband intermodulation performance. The reference measurement channel for the wanted signal is specified in clause 4.3.12.2.2 for each *BS class* and *channel bandwidth*.

The receiver intermodulation requirement is always applicable outside the *Base Station RF bandwidth* or *Maximum Radio Bandwidth* edges. The interfering signal offset is defined relative to the lower (upper) or *Maximum Radio Bandwidth* edges.

For a *TAB connector* operating in *non-contiguous spectrum* within any *operating band*, the narrowband intermodulation requirement applies in addition inside any *sub-block gap* in case the *sub-block gap* is at least as wide as the *channel bandwidth* of the E-UTRA interfering signal. The interfering signal offset is defined relative to the *sub-block* edges inside the *sub-block gap*. The requirement applies separately for both *sub-blocks*.

For a *multi-band TAB connector*, the intermodulation requirement applies in addition inside any *Inter RF Bandwidth gap*, in case the gap size is at least twice as wide as the E-UTRA interfering signal centre frequency offset from the *Base Station RF bandwidth edge*.

For a *multi-band TAB connector*, the narrowband intermodulation requirement applies in addition inside any *Inter RF Bandwidth gap* in case the gap size is at least as wide as the E-UTRA interfering signal in tables 4.3.10.2.3-3, 4.3.10.2.3-4 and 4.3.10.2.3-5. The interfering signal offset is defined relative to the *Base Station RF bandwidth edges* inside the *Inter RF Bandwidth gap*.

Table 4.3.10.2.3-1: E-UTRA intermodulation requirement

BS class	Wanted signal mean power (dBm) (note)	Interfering signal mean power (dBm)	Type of interfering signal
Wide Area BS	$P_{\text{REFSENS}} + 6$ dB	-52	See table 4.3.10.2.3-2
Medium Range BS	$P_{\text{REFSENS}} + 6$ dB	-47	
Local Area BS	$P_{\text{REFSENS}} + 6$ dB	-44	
NOTE: P_{REFSENS} depends on the <i>channel bandwidth</i> as specified in clause 4.3.12.2.2. For E-UTRA <i>channel bandwidths</i> 10, 15 and 20 MHz this requirement shall apply only for a FRC A1-3 mapped to the frequency range at the <i>channel edge</i> adjacent to the interfering signals.			

Table 4.3.10.2.3-2: Interfering signal for E-UTRA intermodulation requirement

E-UTRA channel bandwidth of the lowest (highest) carrier received (MHz)	Interfering signal centre frequency offset from the lower (upper) edge (MHz)	Type of interfering signal
1,4	$\pm 2,1$	CW
	$\pm 4,9$	1,4 MHz E-UTRA signal
3	$\pm 4,5$	CW
	$\pm 10,5$	3 MHz E-UTRA signal
5	$\pm 7,5$	CW
	$\pm 17,5$	5 MHz E-UTRA signal
10	$\pm 7,375$	CW
	$\pm 17,5$	5 MHz E-UTRA signal
15	$\pm 7,25$	CW
	$\pm 17,5$	5 MHz E-UTRA signal
20	$\pm 7,125$	CW
	$\pm 17,5$	5 MHz E-UTRA signal

Table 4.3.10.2.3-3: E-UTRA narrowband intermodulation requirement for Wide Area BS

E-UTRA channel bandwidth of the lowest (highest) carrier received (MHz)	Wanted signal mean power (dBm) (note 1)	Interfering signal mean power (dBm)	Interfering RB centre frequency offset from the lower (upper) edge or <i>sub-block</i> edge inside a <i>sub-block</i> gap (kHz)	Type of interfering signal
1,4	$P_{\text{REFSENS}} + 6 \text{ dB}$	-52	± 270	CW
		-52	± 790	1,4 MHz E-UTRA signal, 1 RB (note 2)
3	$P_{\text{REFSENS}} + 6 \text{ dB}$	-52	± 270	CW
		-52	± 780	3 MHz E-UTRA signal, 1 RB (note 2)
5	$P_{\text{REFSENS}} + 6 \text{ dB}$	-52	± 360	CW
		-52	$\pm 1\ 060$	5 MHz E-UTRA signal, 1 RB (note 2)
10	$P_{\text{REFSENS}} + 6 \text{ dB}$ (note 3)	-52	± 325	CW
		-52	$\pm 1\ 240$	5 MHz E-UTRA signal, 1 RB (note 2)
15	$P_{\text{REFSENS}} + 6 \text{ dB}$ (note 3)	-52	± 380	CW
		-52	$\pm 1\ 600$	5 MHz E-UTRA signal, 1 RB (note 2)
20	$P_{\text{REFSENS}} + 6 \text{ dB}$ (note 3)	-52	± 345	CW
		-52	$\pm 1\ 780$	5 MHz E-UTRA signal, 1 RB (note 2)
NOTE 1:	P_{REFSENS} is related to the <i>channel bandwidth</i> as specified in clause 4.3.12.2.2.			
NOTE 2:	Interfering signal consisting of one resource block positioned at the stated offset, the <i>channel bandwidth</i> of the interfering signal is located adjacently to the lower (upper) edge.			
NOTE 3:	This requirement shall apply only for a FRC A1-3 mapped to the frequency range at the <i>channel edge</i> adjacent to the interfering signals.			

Table 4.3.10.2.3-4: E-UTRA narrowband intermodulation requirement for Medium Range BS

E-UTRA channel bandwidth of the lowest (highest) carrier received (MHz)	Wanted signal mean power (dBm) (note 1)	Interfering signal mean power (dBm)	Interfering RB centre frequency offset to the lower (higher) edge or <i>sub-block</i> edge inside a <i>sub-block</i> gap (kHz)	Type of interfering signal
1,4	$P_{\text{REFSENS}} + 6 \text{ dB}$	-47	± 270	CW
		-47	± 790	1,4 MHz E-UTRA signal, 1 RB (note 2)
3	$P_{\text{REFSENS}} + 6 \text{ dB}$	-47	± 270	CW
		-47	± 780	3 MHz E-UTRA signal, 1 RB (note 2)
5	$P_{\text{REFSENS}} + 6 \text{ dB}$	-47	± 360	CW
		-47	$\pm 1\ 060$	5 MHz E-UTRA signal, 1 RB (note 2)
10	$P_{\text{REFSENS}} + 6 \text{ dB}$ (note 3)	-47	± 325	CW
		-47	$\pm 1\ 240$	5 MHz E-UTRA signal, 1 RB (note 2)
15	$P_{\text{REFSENS}} + 6 \text{ dB}$ (note 3)	-47	± 380	CW
		-47	$\pm 1\ 600$	5 MHz E-UTRA signal, 1 RB (note 2)
20	$P_{\text{REFSENS}} + 6 \text{ dB}$ (note 3)	-47	± 345	CW
		-47	$\pm 1\ 780$	5 MHz E-UTRA signal, 1 RB (note 2)
NOTE 1:	P_{REFSENS} is related to the <i>channel bandwidth</i> as specified in clause 4.3.12.2.2.			
NOTE 2:	Interfering signal consisting of one resource block positioned at the stated offset, the <i>channel bandwidth</i> of the interfering signal is located adjacently to the lower (higher) edge.			
NOTE 3:	This requirement shall apply only for a FRC A1-3 mapped to the frequency range at the <i>channel edge</i> adjacent to the interfering signals.			

Table 4.3.10.2.3-5: E-UTRA narrowband intermodulation requirement for Local Area BS

E-UTRA channel bandwidth of the lowest (highest) carrier received (MHz)	Wanted signal mean power (dBm) (note 1)	Interfering signal mean power (dBm)	Interfering RB centre frequency offset from the lower (upper) edge or <i>sub-block</i> edge inside a <i>sub-block</i> (kHz)	Type of interfering signal
1,4	$P_{\text{REFSENS}} + 6 \text{ dB}$	-44	± 270	CW
		-44	± 790	1,4 MHz E-UTRA signal, 1 RB (note 2)
3	$P_{\text{REFSENS}} + 6 \text{ dB}$	-44	± 275	CW
		-44	± 790	3 MHz E-UTRA signal, 1 RB (note 2)
5	$P_{\text{REFSENS}} + 6 \text{ dB}$	-44	± 360	CW
		-44	$\pm 1\ 060$	5 MHz E-UTRA signal, 1 RB (note 2)
10	$P_{\text{REFSENS}} + 6 \text{ dB}$ (note 3)	-44	± 415	CW
		-44	$\pm 1\ 420$	5 MHz E-UTRA signal, 1 RB (note 2)
15	$P_{\text{REFSENS}} + 6 \text{ dB}$ (note 3)	-44	± 380	CW
		-44	$\pm 1\ 600$	5 MHz E-UTRA signal, 1 RB (note 2)
20	$P_{\text{REFSENS}} + 6 \text{ dB}$ (note 3)	-44	± 345	CW
		-44	$\pm 1\ 780$	5 MHz E-UTRA signal, 1 RB (note 2)
NOTE 1: P_{REFSENS} is related to the <i>channel bandwidth</i> as specified in clause 4.3.12.2.2.				
NOTE 2: Interfering signal consisting of one resource block positioned at the stated offset, the <i>channel bandwidth</i> of the interfering signal is located adjacently to the lower (upper) edge.				
NOTE 3: This requirement shall apply only for a FRC A1-3 mapped to the frequency range at the <i>channel edge</i> adjacent to the interfering signals.				

4.3.10.3 Conformance

The conformance tests for this requirement shall be as defined in clause 5.3.10 of the present document.

4.3.11 Adjacent Channel Selectivity (ACS), general blocking and narrowband blocking

4.3.11.1 Definition and applicability

The adjacent channel selectivity, general blocking and narrowband blocking characteristics are measures of the receiver unit ability to receive a wanted signal at its assigned channel at the *TAB connector* in the presence of an unwanted interferer inside the *operating band*.

NOTE: For Single RAT requirements, the in-band selectivity characteristics is referred to as "adjacent channel selectivity", whereas for the MSR requirements, the corresponding property is referred to as "general blocking" since the adjacent frequency range may not carry a channel addressable from the interfered carrier.

The in-band blocking requirement applies from $F_{\text{UL_low}} - \Delta f_{\text{OOB}}$ to $F_{\text{UL_high}} + \Delta f_{\text{OOB}}$, excluding the downlink frequency range of the *operating band*. The values of Δf_{OOB} are defined in table 4.3.11.1-1.

Table 4.3.11.1-1: Δf_{OOB} offset for *operating bands*

<i>Operating band characteristics</i>	Δf_{OOB} [MHz]
$F_{\text{UL_high}} - F_{\text{UL_low}} < 100 \text{ MHz}$	20
$100 \text{ MHz} \leq F_{\text{UL_high}} - F_{\text{UL_low}} \leq 900 \text{ MHz}$	60

4.3.11.2 Limits

4.3.11.2.1 Limits for *MSR operation*

4.3.11.2.1.1 General blocking limits

For the general blocking requirement, the interfering signal shall be a UTRA FDD signal as specified in clause A.1 in ETSI TS 125 141 [7] for a UTRA, E-UTRA or NR (≤ 20 MHz) wanted signal. The interfering signal shall be a 20 MHz E-UTRA signal for NR wanted signal *channel bandwidth* more than 20 MHz.

For *TAB connector* operating in *non-contiguous spectrum*, the requirement applies in addition inside any *sub-block gap*, in case the *sub-block gap* size is at least 15 MHz. The interfering signal offset is defined relative to the *sub-block* edges inside the *sub-block gap*.

For *multi-band TAB connector* the requirement applies in addition inside any *Inter RF Bandwidth gap*, in case the gap size is at least 15 MHz. The interfering signal offset is defined relative to the *Base Station RF Bandwidth edges* inside the *Inter RF Bandwidth gap*.

For the wanted and interfering signal coupled to the *TAB connector*, using the parameters in table 4.3.11.2.1.1-1, the following requirements shall apply:

- For any UTRA FDD carrier, the BER shall not exceed 0,001 for the reference measurement channel specified in clause 4.3.12.2.1.
- For any E-UTRA carrier, the *throughput* shall be ≥ 95 % of the *maximum throughput* of the reference measurement channel specified in clause 4.3.12.2.2.
- For any NR carrier, the *throughput* shall be ≥ 95 % of the *maximum throughput* of the reference measurement channel specified in clause 4.3.12.2.3.

For a *multi-band TAB connector*, the requirement applies according to table 4.3.11.2.1.1-1 for the in-band blocking frequency ranges of each supported *operating band*.

Table 4.3.11.2.1.1-1: General blocking requirement

BS class	Mean power of interfering signal (dBm)	Wanted Signal mean power (dBm) (note 1)	Centre Frequency of Interfering Signal	Interfering signal centre frequency minimum frequency offset from the <i>Base Station RF Bandwidth edge or sub-block edge inside a gap</i> (MHz)
Wide Area BS	-40 +y (note 7)	$P_{\text{REFSENS}} + x$ dB (notes 2, 5)	$F_{\text{UL_low}} - \Delta f_{\text{OOB}}$ to $F_{\text{UL_high}} + \Delta f_{\text{OOB}}$ (note 8)	$\pm(7,5+z)$ (note 9)
Medium Range BS	-35 +y (note 7)	$P_{\text{REFSENS}} + x$ dB (notes 3, 5)		
Local Area BS	-30 +y (note 7)	$P_{\text{REFSENS}} + x$ dB (notes 4, 5)		
<p>NOTE 1: P_{REFSENS} depends on the RAT, the <i>BS class</i> and on the <i>channel bandwidth</i>, see clause 4.3.12.</p> <p>NOTE 2: For <i>Wide Area BS</i> not supporting NR, "x" is equal to 6 in case of E-UTRA or UTRA wanted signals.</p> <p>NOTE 3: For <i>Medium Range BS</i> not supporting NR, "x" is equal to 6 in case of UTRA wanted signals, 9 in case of E-UTRA wanted signal.</p> <p>NOTE 4: For <i>Local Area BS</i> not supporting NR, "x" is equal to 11 in case of E-UTRA wanted signal, 6 in case of UTRA wanted signal.</p> <p>NOTE 5: For a BS supporting NR and not supporting UTRA, x is equal to 6.</p> <p>NOTE 6: For a BS capable of multi-band operation, "x" in notes 2, 3, 4 and 5 applies in case of interfering signals that are in the in-band blocking frequency range of the <i>operating band</i> where the wanted signal is present or in the in-band blocking frequency range of an adjacent or overlapping operating band. For other in-band blocking frequency ranges of the interfering signal for the supported <i>operating bands</i>, "x" is equal to 1,4 dB.</p> <p>NOTE 7: For a BS not supporting NR, "y" is equal to zero for all <i>BS classes</i>. For a BS supporting NR and not supporting UTRA, "y" is equal to -3 for the <i>Wide Area BS</i> and <i>Medium Range BS</i> and -5 for the <i>Local Area BS</i>.</p> <p>NOTE 8: The downlink frequency range of an FDD <i>operating band</i> is excluded from the general blocking requirement.</p> <p>NOTE 9: For NR wanted signal <i>channel bandwidth</i> more than 20 MHz, $z = 22,5$ MHz. For all other cases, $z = 0$ MHz.</p>				

4.3.11.2.1.2 General narrowband blocking limits

For the narrowband blocking requirement, the interfering signal shall be an E-UTRA 1RB signal as specified in clause A.3 in ETSI TS 137 141 [6].

The requirement is applicable outside the *Base Station RF Bandwidth* or *Maximum Radio Bandwidth*. The interfering signal offset is defined relative to the *Base Station RF Bandwidth edges* or *Maximum Radio Bandwidth edges*.

For a *TAB connector* operating in *non-contiguous spectrum*, the requirement applies in addition inside any *sub-block gap*, in case the *sub-block gap* size is at least 3 MHz. The interfering signal offset is defined relative to the *sub-block edges* inside the *sub-block gap*.

For a *multi-band TAB connector*, the requirement applies in addition inside any *Inter RF Bandwidth gap* in case the gap size is at least 3 MHz. The interfering signal offset is defined relative to the *Base Station RF Bandwidth edges* inside the *Inter RF Bandwidth gap*.

For the wanted and interfering signal coupled to the *TAB connector*, using the parameters in table 4.3.11.2.1.2-1 the following requirements shall apply:

- For any UTRA FDD carrier, the BER shall not exceed 0,001 for the reference measurement channel specified in clause 4.3.12.2.1.
- For any E-UTRA carrier, the *throughput* shall be ≥ 95 % of the *maximum throughput* of the reference measurement channel specified in clause 4.3.12.2.2.
- For any NR carrier, the *throughput* shall be ≥ 95 % of the *maximum throughput* of the reference measurement channel specified in clause 4.3.12.2.3.

Table 4.3.11.2.1.2-1: Narrowband blocking requirement

BS Class	RAT of the carrier	Wanted signal mean power (dBm) (notes 1, 2 and 6)	Interfering signal mean power (dBm)	Interfering RB (note 3) centre frequency offset from the <i>Base Station RF Bandwidth edge</i> or <i>sub-block edge</i> inside a gap (kHz)
Wide Area BS	NR, E-UTRA and UTRA	$P_{\text{REFSENS}} + X \text{ dB}$	-49	$\pm(240+m \times 180)$, $m=0, 1, 2, 3, 4, 9, 14$ (note 4)
Medium Range BS			-44	
Local Area BS			-41	$\pm(550+m \times 180)$, $m=0, 1, 2, 3, 4, 29, 54, 79, 99$ (note 5)
NOTE 1: P_{REFSENS} depends on the RAT, the BS class and on the channel bandwidth, see clause 4.3.12.				
NOTE 2: "x" is equal to 6 in case of E-UTRA, NR or UTRA wanted signals.				
NOTE 3: Interfering signal (E-UTRA 3 MHz) consisting of one resource block positioned at the stated offset, the channel bandwidth of the interfering signal is located adjacently to the Base Station RF Bandwidth edge.				
NOTE 4: Applicable for channel bandwidths equal to or below 20 MHz.				
NOTE 5: Applicable for channel bandwidths above 20 MHz.				
NOTE 6: 7,5 kHz shift is not applied to the wanted signal of NR.				

4.3.11.2.2 Limits for single RAT UTRA operation

The following apply to TAB connectors supporting only single RAT UTRA operation.

For each UTRA carrier, the BER shall not exceed 0,001 for the parameters specified in table 4.3.11.2.2-1.

For multi-carrier TAB connector the ACS requirement is applicable outside the Base Station RF Bandwidth or Maximum Radio Bandwidth. The interfering signal offset is defined relative to the lower/upper Base Station RF Bandwidth edges or Maximum Radio Bandwidth edges.

For a TAB connector operating in non-contiguous spectrum within any operating band, the requirement applies in addition inside any sub-block gap, in case the sub-block gap size is at least 5 MHz. The interfering signal offset is defined relative to the lower/upper sub-block edge inside the sub-block gap and is equal to -2,5 MHz/+2,5 MHz, respectively.

For a multi-band TAB connector, the requirement applies in addition inside any Inter RF Bandwidth gap, in case the Inter RF Bandwidth gap size is at least 5 MHz. The interfering signal offset is defined relative to lower/upper Base Station RF Bandwidth edges inside the Inter RF Bandwidth gap and is equal to -2,5 MHz/+2,5 MHz, respectively.

Table 4.3.11.2.2-1: Adjacent channel selectivity

Parameter	Level	Level	Level	Unit
	Wide Area BS	Medium Range BS	Local Area BS	
Reference measurement channel data rate	12,2	12,2	12,2	kbps
Wanted signal mean power	-115	-105	-101	dBm
Interfering signal mean power	-52	-42	-38	dBm
F_{uw} (Modulated)	± 5	± 5	± 5	MHz

4.3.11.2.3 Limits for single RAT E-UTRA operation

The following apply to TAB connectors supporting only single RAT E-UTRA operation.

For each E-UTRA carrier, the throughput shall be ≥ 95 % of the maximum throughput of the reference measurement channel.

For Wide Area BS the wanted and the interfering signal coupled to the TAB connector are specified in tables 4.3.11.2.3-1 and 4.3.11.2.3-2 for narrowband blocking and 4.3.11.2.3-3 for ACS. The reference measurement channel for the wanted signal is specified in table 4.3.12.2.2-1 for each channel.

For Medium Range BS, the wanted and the interfering signal coupled to the *TAB connector* are specified in tables 4.3.11.2.3-1 and 4.3.11.2.3-2 for narrowband blocking and in table 4.3.11.2.3-4 for ACS. The reference measurement channel for the wanted signal is specified in table 4.3.12.2.2-2 for each *channel bandwidth*.

For Local Area BS, the wanted and the interfering signal coupled to the *TAB connector* are specified in tables 4.3.11.2.3-1 and 4.3.11.2.3-2 for narrowband blocking and 4.3.11.2.3-5 for ACS. The reference measurement channel for the wanted signal is specified in table 4.3.12.2.2-3 for each *channel bandwidth*.

The ACS and narrowband blocking requirement is always applicable outside the *Base Station RF Bandwidth* or *Maximum Radio Bandwidth*. The interfering signal offset is defined relative to the *Base station RF Bandwidth edges* or *Maximum Radio Bandwidth edges*.

For a *TAB connector* operating in *non-contiguous spectrum* within any *operating band*, the ACS requirement applies in addition inside any *sub-block gap*, in case the *sub-block gap* size is at least as wide as the E-UTRA interfering signal in tables 4.3.11.2.3-3, 4.3.11.2.3-4 and 4.3.11.2.3-5. The interfering signal offset is defined relative to the *sub-block* edges inside the *sub-block gap*.

For a *multi-band TAB connector*, the ACS requirement applies in addition inside any *Inter RF Bandwidth gap*, in case the *Inter RF Bandwidth gap* size is at least as wide as the E-UTRA interfering signal in tables 4.3.11.2.3-3, 4.3.11.2.3-4 and 4.3.11.2.3-5. The interfering signal offset is defined relative to the *Base Station RF Bandwidth edges* inside the *Inter RF Bandwidth gap*.

For a *TAB connector* operating in *non-contiguous spectrum* within any *operating band*, the narrowband blocking requirement applies in addition inside any *sub-block gap*, in case the *sub-block gap* size is at least as wide as the *channel bandwidth* of the E-UTRA interfering signal in table 4.3.11.2.3-2. The interfering signal offset is defined relative to the *sub-block* edges inside the *sub-block gap*.

For a *multi-band TAB connector*, the narrowband blocking requirement applies in addition inside any *Inter RF Bandwidth gap*, in case the *Inter RF Bandwidth gap* size is at least as wide as the E-UTRA interfering signal in table 4.3.11.2.3-2. The interfering signal offset is defined relative to the *Base Station RF Bandwidth edges* inside the *Inter RF Bandwidth gap*.

Table 4.3.11.2.3-1: Narrowband blocking requirement

BS Class	Wanted signal mean power (dBm) (note)	Interfering signal mean power (dBm)	Type of interfering signal
Wide Area BS	P _{REFSENS} + 6 dB	-49	See table 4.3.11.2.3-2
Medium Range BS	P _{REFSENS} + 6 dB	-44	See table 4.3.11.2.3-2
Local Area BS	P _{REFSENS} + 6 dB	-41	See table 4.3.11.2.3-2

NOTE: P_{REFSENS} depends on the *channel bandwidth* as specified in clause 4.3.12.

Table 4.3.11.2.3-2: Interfering signal for Narrowband blocking requirement

E-UTRA channel BW of the lowest/highest carrier received (MHz)	Interfering RB centre frequency offset to the lower/upper <i>Base Station RF Bandwidth</i> edge or <i>sub-block</i> edge inside a <i>sub-block gap</i> (kHz)	Type of interfering signal (see note)
1,4	$\pm(252,5+m \times 180)$, m=0, 1, 2, 3, 4, 5	1,4 MHz E-UTRA signal, 1 RB
3	$\pm(247,5+m \times 180)$, m=0, 1, 2, 3, 4, 7, 10, 13	3 MHz E-UTRA signal, 1 RB
5	$\pm(342,5+m \times 180)$, m=0, 1, 2, 3, 4, 9, 14, 19, 24	5 MHz E-UTRA signal, 1 RB
10	$\pm(347,5+m \times 180)$, m=0, 1, 2, 3, 4, 9, 14, 19, 24	5 MHz E-UTRA signal, 1 RB
15	$\pm(352,5+m \times 180)$, m=0, 1, 2, 3, 4, 9, 14, 19, 24	5 MHz E-UTRA signal, 1 RB
20	$\pm(342,5+m \times 180)$, m=0, 1, 2, 3, 4, 9, 14, 19, 24	5 MHz E-UTRA signal, 1 RB

NOTE: Interfering signal consisting of one resource block is positioned at the stated offset, the *channel bandwidth* of the interfering signal is located adjacently to the lower/upper *Base Station RF Bandwidth* edge.

Table 4.3.11.2.3-3: Adjacent channel selectivity for Wide Area BS

E-UTRA channel bandwidth of the lowest/highest carrier received (MHz)	Wanted signal mean power (dBm) (note)	Interfering signal mean power (dBm)	Interfering signal centre frequency offset from the lower/upper Base Station RF Bandwidth edge or sub-block edge inside a sub-block gap (MHz)	Type of interfering signal
1,4	$P_{\text{REFSENS}} + 11$ dB	-52	$\pm 0,7025$	1,4 MHz E-UTRA signal
3	$P_{\text{REFSENS}} + 8$ dB	-52	$\pm 1,5075$	3 MHz E-UTRA signal
5	$P_{\text{REFSENS}} + 6$ dB	-52	$\pm 2,5025$	5 MHz E-UTRA signal
10	$P_{\text{REFSENS}} + 6$ dB	-52	$\pm 2,5075$	5 MHz E-UTRA signal
15	$P_{\text{REFSENS}} + 6$ dB	-52	$\pm 2,5125$	5 MHz E-UTRA signal
20	$P_{\text{REFSENS}} + 6$ dB	-52	$\pm 2,5025$	5 MHz E-UTRA signal

NOTE: P_{REFSENS} depends on the *channel bandwidth* as specified in clause 4.3.12.

Table 4.3.11.2.3-4: Adjacent channel selectivity for Medium Range BS

E-UTRA channel bandwidth of the lowest/highest carrier received (MHz)	Wanted signal mean power (dBm)	Interfering signal mean power (dBm)	Interfering signal centre frequency offset from the lower/upper Base Station RF Bandwidth edge or sub-block edge inside a sub-block gap (MHz)	Type of interfering signal
1,4	$P_{\text{REFSENS}} + 11$ dB	-47	$\pm 0,7025$	1,4 MHz E-UTRA signal
3	$P_{\text{REFSENS}} + 8$ dB	-47	$\pm 1,5075$	3 MHz E-UTRA signal
5	$P_{\text{REFSENS}} + 6$ dB	-47	$\pm 2,5025$	5 MHz E-UTRA signal
10	$P_{\text{REFSENS}} + 6$ dB	-47	$\pm 2,5075$	5 MHz E-UTRA signal
15	$P_{\text{REFSENS}} + 6$ dB	-47	$\pm 2,5125$	5 MHz E-UTRA signal
20	$P_{\text{REFSENS}} + 6$ dB	-47	$\pm 2,5025$	5 MHz E-UTRA signal

NOTE: P_{REFSENS} depends on the *channel bandwidth* as specified in clause 4.3.12.

Table 4.3.11.2.3-5: Adjacent channel selectivity for Local Area BS

E-UTRA channel bandwidth of the lowest/highest carrier received (MHz)	Wanted signal mean power (dBm) (note)	Interfering signal mean power (dBm)	Interfering signal centre frequency offset from the lower/upper Base Station RF Bandwidth edge or sub-block edge inside a sub-block gap (MHz)	Type of interfering signal
1,4	$P_{\text{REFSENS}} + 11$ dB	-44	$\pm 0,7025$	1,4 MHz E-UTRA signal
3	$P_{\text{REFSENS}} + 8$ dB	-44	$\pm 1,5075$	3 MHz E-UTRA signal
5	$P_{\text{REFSENS}} + 6$ dB	-44	$\pm 2,5025$	5 MHz E-UTRA signal
10	$P_{\text{REFSENS}} + 6$ dB	-44	$\pm 2,5075$	5 MHz E-UTRA signal
15	$P_{\text{REFSENS}} + 6$ dB	-44	$\pm 2,5125$	5 MHz E-UTRA signal
20	$P_{\text{REFSENS}} + 6$ dB	-44	$\pm 2,5025$	5 MHz E-UTRA signal

NOTE: P_{REFSENS} depends on the *channel bandwidth* as specified in clause 4.3.12.

4.3.11.3 Conformance

The conformance tests for this requirement shall be as defined in clause 5.3.11 of the present document.

4.3.12 Reference sensitivity level

4.3.12.1 Definition and applicability

The reference sensitivity power level P_{REFSENS} is the minimum mean power received at the *TAB connector* at which a throughput or BER requirement shall be met for a specified reference measurement channel.

4.3.12.2 Limits

4.3.12.2.1 Limits for UTRA FDD operation

For each UTRA carrier, the BER shall not exceed 0,001 with the parameter setting in table 4.3.12.2.1-1.

Reference measurement channel is specified in ETSI TS 125 141 [7], annex A (PN-9 data sequence or longer).

Table 4.3.12.2.1-1: UTRA reference sensitivity parameters

BS class	Reference measurement channel data rate	reference sensitivity level (dBm)	
		$f \leq 3,0$ GHz	$3,0$ GHz $< f \leq 4,2$ GHz
Wide Area BS	12,2 kbps	-120,3	-120,0
Medium Range BS	12,2 kbps	-110,3	-110,0
Local Area BS	12,2 kbps	-106,3	-106,0

4.3.12.2.2 Limits for E-UTRA operation

For each E-UTRA carrier, the *throughput* shall be ≥ 95 % of the *maximum throughput* of the reference measurement channel as specified in ETSI TS 136 141 [11], clause A.1 with parameters specified in tables 4.3.12.2.2-1 to 4.3.12.2.2-3.

Reference measurement channels are specified in ETSI TS 136 141 [11], clause A.1.

Table 4.3.12.2.2-1: E-UTRA Wide Area BS reference sensitivity parameters

E-UTRA channel bandwidth (MHz)	Reference measurement channel	Reference sensitivity power level, P_{REFSENS} (dBm)	
		$f \leq 3,0$ GHz	$3,0$ GHz $< f \leq 4,2$ GHz
1,4	FRC A1-1	-106,1	-105,8
3	FRC A1-2	-102,3	-102,0
5	FRC A1-3	-100,8	-100,5
10	FRC A1-3 (note)	-100,8	-100,5
15	FRC A1-3 (note)	-100,8	-100,5
20	FRC A1-3 (note)	-100,8	-100,5

NOTE: P_{REFSENS} is the power level of a single instance of the reference measurement channel. This requirement shall be met for each consecutive application of a single instance of FRC A1-3 mapped to disjoint frequency ranges with a width of 25 resource blocks each.

Table 4.3.12.2.2-2: E-UTRA Medium Range BS reference sensitivity parameters

E-UTRA channel bandwidth (MHz)	Reference measurement channel	Reference sensitivity power level, P_{REFSENS} (dBm)	
		$f \leq 3,0$ GHz	$3,0$ GHz $< f \leq 4,2$ GHz
1,4	FRC A1-1	-101,1	-100,8
3	FRC A1-2	-97,3	-97,0
5	FRC A1-3	-95,8	-95,5
10	FRC A1-3 (note)	-95,8	-95,5
15	FRC A1-3 (note)	-95,8	-95,5
20	FRC A1-3 (note)	-95,8	-95,5

NOTE: P_{REFSENS} is the power level of a single instance of the reference measurement channel. This requirement shall be met for each consecutive application of a single instance of FRC A1-3 in mapped to disjoint frequency ranges with a width of 25 resource blocks each.

Table 4.3.12.2.2-3: E-UTRA Local Area BS reference sensitivity parameters

E-UTRA channel bandwidth (MHz)	Reference measurement channel	Reference sensitivity power level, P_{REFSENS} (dBm)	
		$f \leq 3,0$ GHz	$3,0$ GHz $< f \leq 4,2$ GHz
1,4	FRC A1-1	-98,1	-97,8
3	FRC A1-2	-94,3	-94,0
5	FRC A1-3	-92,8	-92,5
10	FRC A1-3 (note)	-92,8	-92,5
15	FRC A1-3 (note)	-92,8	-92,5
20	FRC A1-3 (note)	-92,8	-92,5

NOTE: P_{REFSENS} is the power level of a single instance of the reference measurement channel. This requirement shall be met for each consecutive application of a single instance of FRC A1-3 mapped to disjoint frequency ranges with a width of 25 resource blocks each.

4.3.12.2.3 Limits for NR operation

For NR, the *throughput* shall be ≥ 95 % of the *maximum throughput* of the reference measurement channel with parameters specified in tables 4.3.12.2.3-1 to 4.3.12.2.3-3.

Reference measurement channels are specified in ETSI TS 138 141-1 [12], clause A.1.

Table 4.3.12.2.3-1: NR Wide Area BS reference sensitivity parameters

BS channel bandwidth (MHz)	Sub-carrier spacing (kHz)	Reference measurement channel	Reference sensitivity power level, P_{REFSENS} (dBm)	
			$f \leq 3,0$ GHz	$3,0$ GHz $< f \leq 4,2$ GHz
5, 10, 15	15	G-FR1-A1-1	-101	-100,7
10, 15	30	G-FR1-A1-2	-101,1	-100,8
10, 15	60	G-FR1-A1-3	-98,2	-97,9
20, 25, 30, 40, 50	15	G-FR1-A1-4	-94,6	-94,3
20, 25, 30, 40, 50, 60, 70, 80, 90, 100	30	G-FR1-A1-5	-94,9	-94,6
20, 25, 30, 40, 50, 60, 70, 80, 90, 100	60	G-FR1-A1-6	-95	-94,7

NOTE: P_{REFSENS} is the power level of a single instance of the reference measurement channel. This requirement shall be met for each consecutive application of a single instance of the reference measurement channel mapped to disjoint frequency ranges with a width corresponding to the number of resource blocks of the reference measurement channel each, except for one instance that might overlap one other instance to cover the full BS channel bandwidth.

Table 4.3.12.2.3-2: NR Medium Area BS reference sensitivity parameters

BS channel bandwidth (MHz)	Sub-carrier spacing (kHz)	Reference measurement channel	Reference sensitivity power level, P_{REFSENS} (dBm)	
			$f \leq 3,0$ GHz	$3,0$ GHz $< f \leq 4,2$ GHz
5, 10, 15	15	G-FR1-A1-1	-96	-95,7
10, 15	30	G-FR1-A1-2	-96,1	-95,8
10, 15	60	G-FR1-A1-3	-93,2	-92,9
20, 25, 30, 40, 50	15	G-FR1-A1-4	-89,6	-89,3
20, 25, 30, 40, 50, 60, 70, 80, 90, 100	30	G-FR1-A1-5	-89,9	-89,6
20, 25, 30, 40, 50, 60, 70, 80, 90, 100	60	G-FR1-A1-6	-90	-89,7

NOTE: P_{REFSENS} is the power level of a single instance of the reference measurement channel. This requirement shall be met for each consecutive application of a single instance of the reference measurement channel mapped to disjoint frequency ranges with a width corresponding to the number of resource blocks of the reference measurement channel each, except for one instance that might overlap one other instance to cover the full BS channel bandwidth.

Table 4.3.12.2.3-3: NR Local Area BS reference sensitivity parameters

BS channel bandwidth (MHz)	Sub-carrier spacing (kHz)	Reference measurement channel	Reference sensitivity power level, P _{REFSENS} (dBm)	
			f ≤ 3,0 GHz	3,0 GHz < f ≤ 4,2 GHz
5, 10, 15	15	G-FR1-A1-1	-93	-92,7
10, 15	30	G-FR1-A1-2	-93,1	-92,8
10, 15	60	G-FR1-A1-3	-90,2	-89,9
20, 25, 30, 40, 50	15	G-FR1-A1-4	-86,6	-86,3
20, 25, 30, 40, 50, 60, 70, 80, 90, 100	30	G-FR1-A1-5	-86,9	-86,6
20, 25, 30, 40, 50, 60, 70, 80, 90, 100	60	G-FR1-A1-6	-87	-86,7

NOTE: P_{REFSENS} is the power level of a single instance of the reference measurement channel. This requirement shall be met for each consecutive application of a single instance of the reference measurement channel mapped to disjoint frequency ranges with a width corresponding to the number of resource blocks of the reference measurement channel each, except for one instance that might overlap one other instance to cover the full BS channel bandwidth.

4.3.12.3 Conformance

The conformance tests for this requirement shall be as defined in clause 5.3.12 of the present document.

4.3.13 OTA Operating Band Unwanted Emissions (OTA OBUE)

4.3.13.1 Definition and applicability

The OTA limits for *operating band unwanted emissions* are specified as TRP per applicable RIB, as stated in each clause.

The *Operating Band Unwanted Emission* (OBUE) limits for E-UTRA single band and MSR are defined from Δf_{OBUE} below the lowest frequency of each supported *downlink operating band* to the lower *Base Station RF Bandwidth edge* located at $F_{BW,RF,low}$ and from the upper *Base Station RF Bandwidth edge* located at $F_{BW,RF,high}$ up to Δf_{OBUE} above the highest frequency of each supported *downlink operating band*. The values of Δf_{OBUE} are defined in table 4.3.13.1-1.

Table 4.3.13.1-1: Maximum offset of OBUE outside the downlink operating band

BS type	Operating band characteristics	Δf_{OBUE} [MHz]
OTA AAS BS	$F_{DL,high} - F_{DL,low} < 100$ MHz	10
	$100 \text{ MHz} \leq F_{DL,high} - F_{DL,low} \leq 900$ MHz	40

4.3.13.2 Limits

4.3.13.2.1 Limits for MSR operation

4.3.13.2.1.1 General

The following limits shall apply per RIB and BS class, as stated.

4.3.13.2.1.2 Band Categories 1 and 3

For an Wide Area BS operating in Band Category 1 or Band Category 3, the requirement applies outside the *Base Station RF Bandwidth edges*. In addition, for a Wide Area BS operating in *non-contiguous spectrum*, it applies inside any *sub-block gap*. In addition, for an Wide Area BS operating in multiple bands, it applies inside any *Inter RF Bandwidth gap*.

For an Medium Range BS operating in Band Category 1 the requirement applies outside the *Base Station RF Bandwidth edges*. In addition, for a Medium Range BS operating in *non-contiguous spectrum*, it applies inside any *sub-block gap*. In addition, for an Medium Range BS operating in multiple bands, it applies inside any *Inter RF Bandwidth gap*.

For an Local Area BS operating in Band Category 1 the requirement applies outside the *Base Station RF Bandwidth edges*. In addition, for a Local Area BS operating in *non-contiguous spectrum*, it applies inside any *sub-block gap*. In addition, for an Local Area BS operating in multiple bands, it applies inside any *Inter RF Bandwidth gap*.

Outside the *Base Station RF Bandwidth edges*, emissions shall not exceed the limits specified in tables below, where:

- Δf is the separation between the *Base Station RF Bandwidth edge* frequency and the nominal -3 dB point of the measuring filter closest to the carrier frequency.
- f_{offset} is the separation between the *Base Station RF Bandwidth edge* frequency and the centre of the measuring filter.
- $f_{\text{offset}_{\text{max}}}$ is the offset to the frequency Δf_{OBUE} MHz outside the downlink *operating band*.
- Δf_{max} is equal to $f_{\text{offset}_{\text{max}}}$ minus half of the bandwidth of the measuring filter.

For a *multi-band RIB*, inside any *Inter RF Bandwidth gaps* with $W_{\text{gap}} < 2 \times \Delta f_{\text{OBUE}}$ MHz, emissions shall not exceed the cumulative sum of the limits specified at the *Base Station RF Bandwidth edges* on each side of the *Inter RF Bandwidth gap*. The limit for *Base Station RF Bandwidth edge* is specified in tables below, where in this case:

- Δf is the separation between the *Base Station RF Bandwidth edge* frequency and the nominal -3 dB point of the measuring filter closest to the carrier frequency.
- f_{offset} is the separation between the *Base Station RF Bandwidth edge* frequency and the centre of the measuring filter.
- $f_{\text{offset}_{\text{max}}}$ is equal to the *Inter RF Bandwidth gap* divided by two.
- Δf_{max} is equal to $f_{\text{offset}_{\text{max}}}$ minus half of the bandwidth of the measuring filter.

For a *multi-band RIB*, the *operating band unwanted emission* limits apply also in a supported *operating band* without any carriers transmitted, in the case where there are carriers transmitted in another *operating band*. In this case where there is no carrier transmitted in an *operating band*, no cumulative limits are applied in the *inter-band gap* between a supported downlink band with carrier(s) transmitted and a supported downlink band without any carrier transmitted; and:

- In case the *Inter RF Bandwidth gap* between a supported downlink band with carrier(s) transmitted and a supported downlink band without any carrier transmitted is less than $2 \times \Delta f_{\text{OBUE}}$ MHz, $f_{\text{offset}_{\text{max}}}$ shall be the offset to the frequency Δf_{OBUE} MHz outside the outermost edges of the two supported downlink *operating bands* and the *operating band unwanted emission* limit of the band where there are carriers transmitted, as defined in the tables of the present clause, shall apply across both supported downlink bands.
- In other cases, the *operating band unwanted emission* limit of the band where there are carriers transmitted, as defined in the tables of the present clause for the largest frequency offset (Δf_{max}), shall apply from Δf_{OBUE} MHz below the lowest frequency, up to Δf_{OBUE} MHz above the highest frequency of the supported downlink *operating band* without any carrier transmitted.

For a multicarrier *single-band RIB* or a *single-band RIB* configured for intra-band contiguous or non-contiguous carrier aggregation, the definitions above apply to the lower edge of the carrier transmitted at the lowest carrier frequency and the upper edge of the carrier transmitted at the highest carrier frequency within a specified frequency band.

Inside any *sub-block gap* for a *RIB* operating in *non-contiguous spectrum*, emissions shall not exceed the cumulative sum of the limits specified for the adjacent sub-blocks on each side of the *sub-block gap*. The limit for each sub-block is specified in tables below, where in this case:

- Δf is the separation between the sub-block edge frequency and the nominal -3 dB point of the measuring filter closest to the sub-block edge frequency.
- f_{offset} is the separation between the sub-block edge frequency and the centre of the measuring filter.
- $f_{\text{offset}_{\text{max}}}$ is equal to the *sub-block gap* bandwidth divided by two.
- Δf_{max} is equal to $f_{\text{offset}_{\text{max}}}$ minus half of the bandwidth of the measuring filter.

Table 4.3.13.2.1.2-1: Wide Area BS operating band unwanted emissions limits for BC1 and BC3 for bands ≤ 3 GHz except those covered by tables 4.3.13.2.1.2-2a and 4.3.13.2.1.2-2b

Frequency offset of measurement filter -3 dB point, Δf	Frequency offset of measurement filter centre frequency, f_{offset}	Limits (notes 1 and 2)	Measurement bandwidth
$0 \text{ MHz} \leq \Delta f < 0,2 \text{ MHz}$	$0,015 \text{ MHz} \leq f_{\text{offset}} < 0,215 \text{ MHz}$	-3,2 dBm	30 kHz
$0,2 \text{ MHz} \leq \Delta f < 1 \text{ MHz}$	$0,215 \text{ MHz} \leq f_{\text{offset}} < 1,015 \text{ MHz}$	$-3,2 - 15 (f_{\text{offset}}/\text{MHz} - 0,215) \text{ dBm}$	30 kHz
(note 3)	$1,015 \text{ MHz} \leq f_{\text{offset}} < 1,5 \text{ MHz}$	-15,2 dBm	30 kHz
$1 \text{ MHz} \leq \Delta f \leq \min(\Delta f_{\text{max}}, 10 \text{ MHz})$	$1,5 \text{ MHz} \leq f_{\text{offset}} < \min(f_{\text{offset}_{\text{max}}}, 10,5 \text{ MHz})$	-2,2 dBm	1 MHz
$10 \text{ MHz} \leq \Delta f \leq \Delta f_{\text{max}}$	$10,5 \text{ MHz} \leq f_{\text{offset}} < f_{\text{offset}_{\text{max}}}$	-6 dBm (note 4)	1 MHz
NOTE 1: For a RIB supporting <i>non-contiguous spectrum</i> operation within any <i>operating band</i> the limit within <i>sub-block gaps</i> is calculated as a cumulative sum of contributions from adjacent sub-blocks on each side of the <i>sub-block gap</i> , where the contribution from the far-end sub-block shall be scaled according to the measurement bandwidth of the near-end sub-block. Exception is $\Delta f \geq 10 \text{ MHz}$ from both adjacent sub-blocks on each side of the <i>sub-block gap</i> , where the limit within <i>sub-block gaps</i> shall be -6 dBm/MHz.			
NOTE 2: For a <i>multi-band RIB</i> with <i>Inter RF Bandwidth gap</i> $< 2 \times \Delta f_{\text{OBUE}}$ MHz the limit within the <i>Inter RF Bandwidth gaps</i> is calculated as a cumulative sum of contributions from adjacent <i>sub-blocks</i> on each side of the <i>Inter RF Bandwidth gap</i> , where the contribution from the far-end sub-block or <i>Base Station RF Bandwidth</i> shall be scaled according to the measurement bandwidth of the near-end sub-block or <i>Base Station RF Bandwidth</i> .			
NOTE 3: This frequency range ensures that the range of values of f_{offset} is continuous.			
NOTE 4: The requirement is not applicable when $\Delta f_{\text{max}} < 10 \text{ MHz}$.			

Table 4.3.13.2.1.2-2: Wide Area BS operating band unwanted emissions limits for BC1 and BC3 for bands > 3 GHz except those covered by table 4.3.13.2.1.2-2c

Frequency offset of measurement filter -3 dB point, Δf	Frequency offset of measurement filter centre frequency, f_{offset}	Limit (notes 1 and 2)	Measurement bandwidth
$0 \text{ MHz} \leq \Delta f < 0,2 \text{ MHz}$	$0,015 \text{ MHz} \leq f_{\text{offset}} < 0,215 \text{ MHz}$	-3 dBm	30 kHz
$0,2 \text{ MHz} \leq \Delta f < 1 \text{ MHz}$	$0,215 \text{ MHz} \leq f_{\text{offset}} < 1,015 \text{ MHz}$	$-3 - 15 (f_{\text{offset}}/\text{MHz} - 0,215) \text{ dBm}$	30 kHz
(note 3)	$1,015 \text{ MHz} \leq f_{\text{offset}} < 1,5 \text{ MHz}$	-15 dBm	30 kHz
$1 \text{ MHz} \leq \Delta f \leq \min(\Delta f_{\text{max}}, 10 \text{ MHz})$	$1,5 \text{ MHz} \leq f_{\text{offset}} < \min(f_{\text{offset}_{\text{max}}}, 10,5 \text{ MHz})$	-2 dBm	1 MHz
$10 \text{ MHz} \leq \Delta f \leq \Delta f_{\text{max}}$	$10,5 \text{ MHz} \leq f_{\text{offset}} < f_{\text{offset}_{\text{max}}}$	-6 dBm (note 4)	1 MHz
NOTE 1: For a RIB supporting <i>non-contiguous spectrum</i> operation within any <i>operating band</i> the <i>limit</i> within <i>sub-block gaps</i> is calculated as a cumulative sum of contributions from adjacent sub-blocks on each side of the <i>sub-block gap</i> , where the contribution from the far-end sub-block shall be scaled according to the measurement bandwidth of the near-end sub-block. Exception is $\Delta f \geq 10 \text{ MHz}$ from both adjacent sub-blocks on each side of the <i>sub-block gap</i> , where the <i>limit</i> within <i>sub-block gaps</i> shall be -6 dBm/MHz.			
NOTE 2: For a <i>multi-band RIB</i> with <i>Inter RF Bandwidth gap</i> $< 2 \times \Delta f_{\text{OBUE}}$ MHz the <i>limit</i> within the <i>Inter RF Bandwidth gaps</i> is calculated as a cumulative sum of contributions from adjacent <i>sub-blocks</i> on each side of the <i>Inter RF Bandwidth gap</i> , where the contribution from the far-end sub-block or <i>Base Station RF Bandwidth</i> shall be scaled according to the measurement bandwidth of the near-end sub-block or <i>Base Station RF Bandwidth</i> .			
NOTE 3: This frequency range ensures that the range of values of f_{offset} is continuous.			
NOTE 4: The requirement is not applicable when $\Delta f_{\text{max}} < 10 \text{ MHz}$.			

Table 4.3.13.2.1.2-2a: Wide Area BS operating band unwanted emissions limits for BC1 and BC3 for bands ≤ 1 GHz, for BS supporting NR and not supporting UTRA

Frequency offset of measurement filter -3 dB point, Δf	Frequency offset of measurement filter centre frequency, f_{offset}	Limit (notes 1 and 2)	Measurement bandwidth
$0 \text{ MHz} \leq \Delta f < 5 \text{ MHz}$	$0,05 \text{ MHz} \leq f_{\text{offset}} < 5,05 \text{ MHz}$	$3,8 \text{ dBm} - 7/5 (f_{\text{offset}}/\text{MHz} - 0,05) \text{ dB}$	100 kHz
$5 \text{ MHz} \leq \Delta f < \min(10 \text{ MHz}, \Delta f_{\text{max}})$	$5,05 \text{ MHz} \leq f_{\text{offset}} < \min(10,05 \text{ MHz}, f_{\text{offset}_{\text{max}}})$	-3,2 dBm	100 kHz
$10 \text{ MHz} \leq \Delta f \leq \Delta f_{\text{max}}$	$10,05 \text{ MHz} \leq f_{\text{offset}} < f_{\text{offset}_{\text{max}}}$	-7 dBm (note 3)	100 kHz
NOTE 1: For a RIB supporting <i>non-contiguous spectrum</i> operation within any <i>operating band</i> , the limit within <i>sub-block gaps</i> is calculated as a cumulative sum of contributions from adjacent sub-blocks on each side of the <i>sub-block gap</i> . Exception is $\Delta f \geq 10$ MHz from both adjacent sub-blocks on each side of the <i>sub-block gap</i> , where the limit within <i>sub-block gaps</i> shall be -7 dBm/100 kHz.			
NOTE 2: For a <i>multi-band RIB</i> with <i>Inter RF Bandwidth gap</i> $< 2 \times \Delta f_{\text{OBUE}}$ the limit within the <i>Inter RF Bandwidth gaps</i> is calculated as a cumulative sum of contributions from adjacent <i>sub-blocks</i> or <i>Base Station RF Bandwidth</i> on each side of the <i>Inter RF Bandwidth gap</i> .			
NOTE 3: The requirement is not applicable when $\Delta f_{\text{max}} < 10$ MHz.			

Table 4.3.13.2.1.2-2b: Wide Area BS operating band unwanted emissions limits for BC1 and BC3 for bands > 1 GHz and ≤ 3 GHz, for BS supporting NR (except operation in Band 1 or 65) and not supporting UTRA

Frequency offset of measurement filter -3 dB point, Δf	Frequency offset of measurement filter centre frequency, f_{offset}	Limit (notes 1 and 2)	Measurement bandwidth
$0 \text{ MHz} \leq \Delta f < 5 \text{ MHz}$	$0,05 \text{ MHz} \leq f_{\text{offset}} < 5,05 \text{ MHz}$	$3,8 \text{ dBm} - 7/5 (f_{\text{offset}}/\text{MHz} - 0,05) \text{ dB}$	100 kHz
$5 \text{ MHz} \leq \Delta f < \min(10 \text{ MHz}, \Delta f_{\text{max}})$	$5,05 \text{ MHz} \leq f_{\text{offset}} < \min(10,05 \text{ MHz}, f_{\text{offset}_{\text{max}}})$	-3,2 dBm	100 kHz
$10 \text{ MHz} \leq \Delta f \leq \Delta f_{\text{max}}$	$10,5 \text{ MHz} \leq f_{\text{offset}} < f_{\text{offset}_{\text{max}}}$	-6 dBm (note 3)	1 MHz
NOTE 1: For a RIB supporting <i>non-contiguous spectrum</i> operation within any <i>operating band</i> , the limit within <i>sub-block gaps</i> is calculated as a cumulative sum of contributions from adjacent sub-blocks on each side of the <i>sub-block gap</i> . Exception is $\Delta f \geq 10$ MHz from both adjacent sub-blocks on each side of the <i>sub-block gap</i> , where the limit within <i>sub-block gaps</i> shall be -6 dBm/MHz.			
NOTE 2: For a <i>multi-band RIB</i> with <i>Inter RF Bandwidth gap</i> $< 2 \times \Delta f_{\text{OBUE}}$ the limit within the <i>Inter RF Bandwidth gaps</i> is calculated as a cumulative sum of contributions from adjacent <i>sub-blocks</i> or <i>Base Station RF Bandwidth</i> on each side of the <i>Inter RF Bandwidth gap</i> .			
NOTE 3: The requirement is not applicable when $\Delta f_{\text{max}} < 10$ MHz.			

Table 4.3.13.2.1.2-2c: Wide Area BS operating band unwanted emissions limits for BC1 and BC3 for bands > 3 GHz for BS supporting NR and not supporting UTRA

Frequency offset of measurement filter -3 dB point, Δf	Frequency offset of measurement filter centre frequency, f_{offset}	Limit (notes 1 and 2)	Measurement bandwidth
$0 \text{ MHz} \leq \Delta f < 5 \text{ MHz}$	$0,05 \text{ MHz} \leq f_{\text{offset}} < 5,05 \text{ MHz}$	$-4 \text{ dBm} - 7/5 (f_{\text{offset}}/\text{MHz} - 0,05) \text{ dB}$	100 kHz
$5 \text{ MHz} \leq \Delta f < \min(10 \text{ MHz}, \Delta f_{\text{max}})$	$5,05 \text{ MHz} \leq f_{\text{offset}} < \min(10,05 \text{ MHz}, f_{\text{offset}_{\text{max}}})$	-3 dBm	100 kHz
$10 \text{ MHz} \leq \Delta f \leq \Delta f_{\text{max}}$	$10,5 \text{ MHz} \leq f_{\text{offset}} < f_{\text{offset}_{\text{max}}}$	-6 dBm (note 3)	1 MHz
NOTE 1: For a RIB supporting <i>non-contiguous spectrum</i> operation within any <i>operating band</i> , the limit within <i>sub-block gaps</i> is calculated as a cumulative sum of contributions from adjacent sub-blocks on each side of the <i>sub-block gap</i> . Exception is $\Delta f \geq 10$ MHz from both adjacent sub-blocks on each side of the <i>sub-block gap</i> , where the limit within <i>sub-block gaps</i> shall be -6 dBm/MHz.			
NOTE 2: For a <i>multi-band RIB</i> with <i>Inter RF Bandwidth gap</i> $< 2 \times \Delta f_{\text{OBUE}}$ the limit within the <i>Inter RF Bandwidth gaps</i> is calculated as a cumulative sum of contributions from adjacent <i>sub-blocks</i> or <i>RF Bandwidth</i> on each side of the <i>Inter RF Bandwidth gap</i> .			
NOTE 3: The requirement is not applicable when $\Delta f_{\text{max}} < 10$ MHz.			

Table 4.3.13.2.1.2-3: Medium Range BS operating band unwanted emissions limits for BC1 for bands ≤ 3 GHz, $40 < P_{\text{rated,c,TRP}} \leq 47$ dBm for BS not supporting NR

Frequency offset of measurement filter -3 dB point, Δf	Frequency offset of measurement filter centre frequency, f_{offset}	Limit (notes 1 and 2)	Measurement bandwidth
$0 \text{ MHz} \leq \Delta f < 0,6 \text{ MHz}$	$0,015 \text{ MHz} \leq f_{\text{offset}} < 0,615 \text{ MHz}$	$P_{\text{rated,c,TRP}} - 56,2 \text{ dB} - (5/3) \times (f_{\text{offset}} - 0,015) \text{ dB}$	30 kHz
$0,6 \text{ MHz} \leq \Delta f < 1 \text{ MHz}$	$0,615 \text{ MHz} \leq f_{\text{offset}} < 1,015 \text{ MHz}$	$P_{\text{rated,c,TRP}} - 51,2 \text{ dB} - 15 \times (f_{\text{offset}} - 0,015) \text{ dB}$	30 kHz
(note 3)	$1,015 \text{ MHz} \leq f_{\text{offset}} < 1,5 \text{ MHz}$	$P_{\text{rated,c,TRP}} - 63,2 \text{ dB}$	30 kHz
$1 \text{ MHz} \leq \Delta f \leq 2,6 \text{ MHz}$	$1,5 \text{ MHz} \leq f_{\text{offset}} < 3,1 \text{ MHz}$	$P_{\text{rated,c,TRP}} - 50,2 \text{ dB}$	1 MHz
$2,6 \text{ MHz} \leq \Delta f \leq 5 \text{ MHz}$	$3,1 \text{ MHz} \leq f_{\text{offset}} < 5,5 \text{ MHz}$	$\min(P_{\text{rated,c,TRP}} - 50,2 \text{ dB}, -4,2 \text{ dBm})$	1 MHz
$5 \text{ MHz} \leq \Delta f \leq \min(\Delta f_{\text{max}}, 10 \text{ MHz})$	$5,5 \text{ MHz} \leq f_{\text{offset}} < \min(f_{\text{offset}_{\text{max}}}, 10,5 \text{ MHz})$	$P_{\text{rated,c,TRP}} - 54,2 \text{ dB}$	1 MHz
$10 \text{ MHz} \leq \Delta f \leq \Delta f_{\text{max}}$	$10,5 \text{ MHz} \leq f_{\text{offset}} < f_{\text{offset}_{\text{max}}}$	$P_{\text{rated,c,TRP}} - 56 \text{ dB}$ (note 4)	1 MHz
NOTE 1: For a RIB supporting <i>non-contiguous spectrum</i> operation within any <i>operating band</i> the <i>limit</i> within <i>sub-block gaps</i> is calculated as a cumulative sum of contributions from adjacent sub-blocks on each side of the <i>sub-block gap</i> , where the contribution from the far-end sub-block shall be scaled according to the measurement bandwidth of the near-end sub-block. Exception is $\Delta f \geq 10$ MHz from both adjacent sub-blocks on each side of the <i>sub-block gap</i> , where the <i>limit</i> within <i>sub-block gaps</i> shall be $(P_{\text{rated,c,TRP}} - 56 \text{ dB})/\text{MHz}$.			
NOTE 2: For a <i>multi-band RIB</i> with <i>Inter RF Bandwidth gap</i> $< 2 \times \Delta f_{\text{OBUE}}$ MHz the <i>limit</i> within the <i>Inter RF Bandwidth gaps</i> is calculated as a cumulative sum of contributions from adjacent <i>sub-blocks</i> on each side of the <i>Inter RF Bandwidth gap</i> , where the contribution from the far-end sub-block or <i>Base Station RF Bandwidth</i> shall be scaled according to the measurement bandwidth of the near-end sub-block or <i>Base Station RF Bandwidth</i> .			
NOTE 3: This frequency range ensures that the range of values of f_{offset} is continuous.			
NOTE 4: The requirement is not applicable when $\Delta f_{\text{max}} < 10$ MHz.			

Table 4.3.13.2.1.2-3a: Medium Range BS operating band unwanted emissions limits for BS supporting NR and not supporting UTRA in BC1 bands ≤ 3 GHz, BS maximum output power $40 < P_{\text{rated,c,TRP}} \leq 47$ dBm

Frequency offset of measurement filter -3 dB point, Δf	Frequency offset of measurement filter centre frequency, f_{offset}	LimitLimit (notes 1 and 2)	Measurement bandwidth
$0 \text{ MHz} \leq \Delta f < 5 \text{ MHz}$	$0,05 \text{ MHz} \leq f_{\text{offset}} < 5,05 \text{ MHz}$	$P_{\text{rated,c,TRP}} - 51,2 \text{ dB} - (7/5) \times (f_{\text{offset}} - 0,05) \text{ dB}$	100 kHz
$5 \text{ MHz} \leq \Delta f < \min(10 \text{ MHz}, \Delta f_{\text{max}})$	$5,05 \text{ MHz} \leq f_{\text{offset}} < \min(10,05 \text{ MHz}, f_{\text{offset}_{\text{max}}})$	$P_{\text{rated,c,TRP}} - 58,2 \text{ dB}$	100 kHz
$10 \text{ MHz} \leq \Delta f \leq \Delta f_{\text{max}}$	$10,05 \text{ MHz} \leq f_{\text{offset}} < f_{\text{offset}_{\text{max}}}$	$\text{Min}(P_{\text{rated,c,TRP}} - 60 \text{ dB}, -16 \text{ dBm})$ (note 3)	100 kHz
NOTE 1: For a RIB supporting <i>non-contiguous spectrum</i> operation within any <i>operating band</i> the <i>limit</i> within <i>sub-block gaps</i> is calculated as a cumulative sum of contributions from adjacent sub-blocks on each side of the <i>sub-block gap</i> . Exception is $\Delta f \geq 10$ MHz from both adjacent sub-blocks on each side of the <i>sub-block gap</i> , where the <i>limit</i> within <i>sub-block gaps</i> shall be $\text{Min}(P_{\text{rated,c,TRP}} - 60 \text{ dB}, -16 \text{ dBm})/100 \text{ kHz}$.			
NOTE 2: For a <i>multi-band RIB</i> with <i>Inter RF Bandwidth gap</i> $< 2 \times \Delta f_{\text{OBUE}}$ the <i>limit</i> within the <i>Inter RF Bandwidth gaps</i> is calculated as a cumulative sum of contributions from adjacent <i>sub-blocks</i> or <i>Base Station RF Bandwidth</i> on each side of the <i>Inter RF Bandwidth gap</i> .			
NOTE 3: The requirement is not applicable when $\Delta f_{\text{max}} < 10$ MHz.			

Table 4.3.13.2.1.2-4: Medium Range BS operating band unwanted emissions limits for BC1 for bands > 3 GHz, $40 < P_{\text{rated,c,TRP}} \leq 47$ dBm for BS not supporting NR

Frequency offset of measurement filter -3 dB point, Δf	Frequency offset of measurement filter centre frequency, f_{offset}	Limit (notes 1 and 2)	Measurement bandwidth
$0 \text{ MHz} \leq \Delta f < 0,6 \text{ MHz}$	$0,015 \text{ MHz} \leq f_{\text{offset}} < 0,615 \text{ MHz}$	$P_{\text{rated,c,TRP}} - 56 \text{ dB} - (5/3) \times (f_{\text{offset}} - 0,015) \text{ dB}$	30 kHz
$0,6 \text{ MHz} \leq \Delta f < 1 \text{ MHz}$	$0,615 \text{ MHz} \leq f_{\text{offset}} < 1,015 \text{ MHz}$	$P_{\text{rated,c,TRP}} - 51 \text{ dB} - 15 \times (f_{\text{offset}} - 0,615) \text{ dB}$	30 kHz
(note 3)	$1,015 \text{ MHz} \leq f_{\text{offset}} < 1,5 \text{ MHz}$	$P_{\text{rated,c,TRP}} - 63 \text{ dB}$	30 kHz
$1 \text{ MHz} \leq \Delta f \leq 2,6 \text{ MHz}$	$1,5 \text{ MHz} \leq f_{\text{offset}} < 3,1 \text{ MHz}$	$P_{\text{rated,c,TRP}} - 50 \text{ dB}$	1 MHz
$2,6 \text{ MHz} \leq \Delta f \leq 5 \text{ MHz}$	$3,1 \text{ MHz} \leq f_{\text{offset}} < 5,5 \text{ MHz}$	$\min(P_{\text{rated,c,TRP}} - 50 \text{ dB}, -4 \text{ dBm})$	1 MHz
$5 \text{ MHz} \leq \Delta f \leq \min(\Delta f_{\text{max}}, 10 \text{ MHz})$	$5,5 \text{ MHz} \leq f_{\text{offset}} < \min(f_{\text{offset}_{\text{max}}}, 10,5 \text{ MHz})$	$P_{\text{rated,c,TRP}} - 54 \text{ dB}$	1 MHz
$10 \text{ MHz} \leq \Delta f \leq \Delta f_{\text{max}}$	$10,5 \text{ MHz} \leq f_{\text{offset}} < f_{\text{offset}_{\text{max}}}$	$P_{\text{rated,c,TRP}} - 56 \text{ dB}$ (note 4)	1 MHz
NOTE 1: For a RIB supporting <i>non-contiguous spectrum</i> operation within any <i>operating band</i> the <i>limit</i> within <i>sub-block gaps</i> is calculated as a cumulative sum of contributions from adjacent sub-blocks on each side of the <i>sub-block gap</i> , where the contribution from the far-end sub-block shall be scaled according to the measurement bandwidth of the near-end sub-block. Exception is $\Delta f \geq 10$ MHz from both adjacent sub-blocks on each side of the <i>sub-block gap</i> , where the <i>limit</i> within <i>sub-block gaps</i> shall be $(P_{\text{rated,c,TRP}} - 56 \text{ dB})/\text{MHz}$.			
NOTE 2: For a <i>multi-band RIB</i> with <i>Inter RF Bandwidth gap</i> $< 2 \times \Delta f_{\text{OBUE}}$ MHz the <i>limit</i> within the <i>Inter RF Bandwidth gaps</i> is calculated as a cumulative sum of contributions from adjacent <i>sub-blocks</i> on each side of the <i>Inter RF Bandwidth gap</i> , where the contribution from the far-end sub-block or <i>Base Station RF Bandwidth</i> shall be scaled according to the measurement bandwidth of the near-end sub-block or <i>Base Station RF Bandwidth</i> .			
NOTE 3: This frequency range ensures that the range of values of f_{offset} is continuous.			
NOTE 4: The requirement is not applicable when $\Delta f_{\text{max}} < 10$ MHz.			

Table 4.3.13.2.1.2-4a: Medium Range BS operating band unwanted emissions limits for BS supporting NR and not supporting UTRA in BC1 bands > 3 GHz, BS maximum output power $40 < P_{\text{rated,c,TRP}} \leq 47$ dBm

Frequency offset of measurement filter -3 dB point, Δf	Frequency offset of measurement filter centre frequency, f_{offset}	LimitLimit (notes 1 and 2)	Measurement bandwidth
$0 \text{ MHz} \leq \Delta f < 5 \text{ MHz}$	$0,05 \text{ MHz} \leq f_{\text{offset}} < 5,05 \text{ MHz}$	$P_{\text{rated,c,TRP}} - 51 \text{ dB} - 7/5(f_{\text{offset}}/\text{MHz} - 0,05) \text{ dB}$	100 kHz
$5 \text{ MHz} \leq \Delta f < \min(10 \text{ MHz}, \Delta f_{\text{max}})$	$5,05 \text{ MHz} \leq f_{\text{offset}} < \min(10,05 \text{ MHz}, f_{\text{offset}_{\text{max}}})$	$P_{\text{rated,c,TRP}} - 58 \text{ dB}$	100 kHz
$10 \text{ MHz} \leq \Delta f \leq \Delta f_{\text{max}}$	$10,05 \text{ MHz} \leq f_{\text{offset}} < f_{\text{offset}_{\text{max}}}$	$\text{Min}(P_{\text{rated,c,TRP}} - 60 \text{ dB}, -16 \text{ dBm})$ (note 3)	100 kHz
NOTE 1: For a RIB supporting <i>non-contiguous spectrum</i> operation within any <i>operating band</i> the <i>limit</i> within <i>sub-block gaps</i> is calculated as a cumulative sum of contributions from adjacent sub-blocks on each side of the <i>sub-block gap</i> . Exception is $\Delta f \geq 10$ MHz from both adjacent sub-blocks on each side of the <i>sub-block gap</i> , where the <i>limit</i> within <i>sub-block gaps</i> shall be $\text{Min}(P_{\text{rated,c,TRP}} - 60 \text{ dB}, -16 \text{ dBm})/100 \text{ kHz}$.			
NOTE 2: For a <i>multi-band RIB</i> with <i>Inter RF Bandwidth gap</i> $< 2 \times \Delta f_{\text{OBUE}}$ the <i>limit</i> within the <i>Inter RF Bandwidth gaps</i> is calculated as a cumulative sum of contributions from adjacent <i>sub-blocks</i> or <i>Base Station RF Bandwidth</i> on each side of the <i>Inter RF Bandwidth gap</i> .			
NOTE 3: The requirement is not applicable when $\Delta f_{\text{max}} < 10$ MHz.			

Table 4.3.13.2.1.2-5: Medium Range BS operating band unwanted emissions limits for BC1 for bands ≤ 3 GHz, $P_{\text{rated,c,TRP}} \leq 40$ dBm for BS not supporting NR

Frequency offset of measurement filter -3 dB point, Δf	Frequency offset of measurement filter centre frequency, f_{offset}	Limit (notes 1 and 2)	Measurement bandwidth
$0 \text{ MHz} \leq \Delta f < 0,6 \text{ MHz}$	$0,015 \text{ MHz} \leq f_{\text{offset}} < 0,615 \text{ MHz}$	$-16,2 - 5/3(f_{\text{offset}}/\text{MHz} - 0,015) \text{ dBm}$	30 kHz
$0,6 \text{ MHz} \leq \Delta f < 1 \text{ MHz}$	$0,615 \text{ MHz} \leq f_{\text{offset}} < 1,015 \text{ MHz}$	$-11,2 - 15(f_{\text{offset}}/\text{MHz} - 0,015) \text{ dBm}$	30 kHz
(note 3)	$1,015 \text{ MHz} \leq f_{\text{offset}} < 1,5 \text{ MHz}$	-23,2 dBm	30 kHz
$1 \text{ MHz} \leq \Delta f \leq 5 \text{ MHz}$	$1,5 \text{ MHz} \leq f_{\text{offset}} < 5,5 \text{ MHz}$	-10,2 dBm	1 MHz
$5 \text{ MHz} \leq \Delta f \leq \min(\Delta f_{\text{max}}, 10 \text{ MHz})$	$5,5 \text{ MHz} \leq f_{\text{offset}} < \min(f_{\text{offsetmax}}, 10,5 \text{ MHz})$	-14,2 dBm	1 MHz
$10 \text{ MHz} \leq \Delta f \leq \Delta f_{\text{max}}$	$10,5 \text{ MHz} \leq f_{\text{offset}} < f_{\text{offsetmax}}$	-16 dBm (note 4)	1 MHz

NOTE 1: For a RIB supporting *non-contiguous spectrum* operation within any *operating band* the *limit* within *sub-block gaps* is calculated as a cumulative sum of contributions from adjacent sub-blocks on each side of the *sub-block gap*, where the contribution from the far-end sub-block shall be scaled according to the measurement bandwidth of the near-end sub-block. Exception is $\Delta f \geq 10$ MHz from both adjacent sub-blocks on each side of the *sub-block gap*, where the *limit* within *sub-block gaps* shall be -16 dBm/MHz.

NOTE 2: For a *multi-band RIB* with *Inter RF Bandwidth gap* $< 2 \times \Delta f_{\text{OBUE}}$ MHz the *limit* within the *Inter RF Bandwidth gaps* is calculated as a cumulative sum of contributions from adjacent *sub-blocks* on each side of the *Inter RF Bandwidth gap*, where the contribution from the far-end sub-block or *Base Station RF Bandwidth* shall be scaled according to the measurement bandwidth of the near-end sub-block or *Base Station RF Bandwidth*.

NOTE 3: This frequency range ensures that the range of values of f_{offset} is continuous.

NOTE 4: The requirement is not applicable when $\Delta f_{\text{max}} < 10$ MHz.

Table 4.3.13.2.1.2-5a: Medium Range BS operating band unwanted emissions limits for BS supporting NR and not supporting UTRA in BC1 bands ≤ 3 GHz, BS maximum output power $P_{\text{rated,c,TRP}} \leq 40$ dBm

Frequency offset of measurement filter -3 dB point, Δf	Frequency offset of measurement filter centre frequency, f_{offset}	Limit (notes 1 and 2)	Measurement bandwidth (note 7)
$0 \text{ MHz} \leq \Delta f < 5 \text{ MHz}$	$0,05 \text{ MHz} \leq f_{\text{offset}} < 5,05 \text{ MHz}$	$-11,2 \text{ dBm} - 7/5(f_{\text{offset}}/\text{MHz} - 0,05) \text{ dB}$	100 kHz
$5 \text{ MHz} \leq \Delta f < \min(10 \text{ MHz}, \Delta f_{\text{max}})$	$5,05 \text{ MHz} \leq f_{\text{offset}} < \min(10,05 \text{ MHz}, f_{\text{offsetmax}})$	-18,2 dBm	100 kHz
$10 \text{ MHz} \leq \Delta f \leq \Delta f_{\text{max}}$	$10,05 \text{ MHz} \leq f_{\text{offset}} < f_{\text{offsetmax}}$	-20 dBm (note 3)	100 kHz

NOTE 1: For a RIB supporting *non-contiguous spectrum* operation within any *operating band* the *limit* within *sub-block gaps* is calculated as a cumulative sum of contributions from adjacent sub-blocks on each side of the *sub-block gap*. Exception is $\Delta f \geq 10$ MHz from both adjacent sub-blocks on each side of the *sub-block gap*, where the *limit* within *sub-block gaps* shall be -20 dBm/100 kHz.

NOTE 2: For a *multi-band RIB* with *Inter RF Bandwidth gap* $< 2 \times \Delta f_{\text{OBUE}}$ the *limit* within the *Inter RF Bandwidth gaps* is calculated as a cumulative sum of contributions from adjacent *sub-blocks* or *Base Station RF Bandwidth* on each side of the *Inter RF Bandwidth*.

NOTE 3: The requirement is not applicable when $\Delta f_{\text{max}} < 10$ MHz.

Table 4.3.13.2.1.2-6: Medium Range BS operating band unwanted emissions limits for BC1 for bands > 3 GHz, $P_{\text{rated,c,TRP}} \leq 40$ dBm for BS not supporting NR

Frequency offset of measurement filter -3 dB point, Δf	Frequency offset of measurement filter centre frequency, f_{offset}	Limit (notes 1 and 2)	Measurement bandwidth
$0 \text{ MHz} \leq \Delta f < 0,6 \text{ MHz}$	$0,015 \text{ MHz} \leq f_{\text{offset}} < 0,615 \text{ MHz}$	$-16 - 5/3(f_{\text{offset}}/\text{MHz} - 0,015) \text{ dBm}$	30 kHz
$0,6 \text{ MHz} \leq \Delta f < 1 \text{ MHz}$	$0,615 \text{ MHz} \leq f_{\text{offset}} < 1,015 \text{ MHz}$	$-11 - 15(f_{\text{offset}}/\text{MHz} - 0,615) \text{ dBm}$	30 kHz
(note 3)	$1,015 \text{ MHz} \leq f_{\text{offset}} < 1,5 \text{ MHz}$	-23 dBm	30 kHz
$1 \text{ MHz} \leq \Delta f \leq 5 \text{ MHz}$	$1,5 \text{ MHz} \leq f_{\text{offset}} < 5,5 \text{ MHz}$	-10 dBm	1 MHz
$5 \text{ MHz} \leq \Delta f \leq \min(\Delta f_{\text{max}}, 10 \text{ MHz})$	$5,5 \text{ MHz} \leq f_{\text{offset}} < \min(f_{\text{offset}_{\text{max}}}, 10,5 \text{ MHz})$	-14 dBm	1 MHz
$10 \text{ MHz} \leq \Delta f \leq \Delta f_{\text{max}}$	$10,5 \text{ MHz} \leq f_{\text{offset}} < f_{\text{offset}_{\text{max}}}$	-16 dBm (note 4)	1 MHz
<p>NOTE 1: For a RIB supporting <i>non-contiguous spectrum</i> operation within any <i>operating band</i> the <i>limit</i> within <i>sub-block gaps</i> is calculated as a cumulative sum of contributions from adjacent sub-blocks on each side of the <i>sub-block gap</i>, where the contribution from the far-end <i>sub-block</i> shall be scaled according to the <i>measurement bandwidth</i> of the near-end <i>sub-block</i>. Exception is $\Delta f \geq 10$ MHz from both adjacent sub-blocks on each side of the <i>sub-block gap</i>, where the <i>limit</i> within <i>sub-block gaps</i> shall be -16 dBm/MHz.</p> <p>NOTE 2: For a <i>multi-band RIB</i> with <i>Inter RF Bandwidth gap</i> $< 2 \times \Delta f_{\text{OBUE}}$ MHz the <i>limit</i> within the <i>Inter RF Bandwidth gaps</i> is calculated as a cumulative sum of contributions from adjacent <i>sub-blocks</i> on each side of the <i>Inter RF Bandwidth gap</i>, where the contribution from the far-end sub-block or <i>Base Station RF Bandwidth</i> shall be scaled according to the measurement bandwidth of the near-end sub-block or <i>Base Station RF Bandwidth</i>.</p> <p>NOTE 3: This frequency range ensures that the range of values of f_{offset} is continuous.</p> <p>NOTE 4: The requirement is not applicable when $\Delta f_{\text{max}} < 10$ MHz.</p>			

Table 4.3.13.2.1.2-6a: Medium Range BS operating band unwanted emissions limits for BS supporting NR and not supporting UTRA in BC1 bands > 3 GHz, BS maximum output power $P_{\text{rated,c,TRP}} \leq 40$ dBm

Frequency offset of measurement filter -3 dB point, Δf	Frequency offset of measurement filter centre frequency, f_{offset}	Limit (notes 1 and 2)	Measurement bandwidth
$0 \text{ MHz} \leq \Delta f < 5 \text{ MHz}$	$0,05 \text{ MHz} \leq f_{\text{offset}} < 5,05 \text{ MHz}$	$-11 \text{ dBm} - 7/5(f_{\text{offset}}/\text{MHz} - 0,05) \text{ dB}$	100 kHz
$5 \text{ MHz} \leq \Delta f < \min(10 \text{ MHz}, \Delta f_{\text{max}})$	$5,05 \text{ MHz} \leq f_{\text{offset}} < \min(10,05 \text{ MHz}, f_{\text{offset}_{\text{max}}})$	-18 dBm	100 kHz
$10 \text{ MHz} \leq \Delta f \leq \Delta f_{\text{max}}$	$10,05 \text{ MHz} \leq f_{\text{offset}} < f_{\text{offset}_{\text{max}}}$	-20 dBm (note 3)	100 kHz
<p>NOTE 1: For a RIB supporting <i>non-contiguous spectrum</i> operation within any <i>operating band</i> the <i>limit</i> within <i>sub-block gaps</i> is calculated as a cumulative sum of contributions from adjacent sub-blocks on each side of the <i>sub-block gap</i>. Exception is $\Delta f \geq 10$ MHz from both adjacent sub-blocks on each side of the <i>sub-block gap</i>, where the <i>limit</i> within <i>sub-block gaps</i> shall be -20 dBm/100 kHz.</p> <p>NOTE 2: For a <i>multi-band RIB</i> with <i>Inter RF Bandwidth gap</i> $< 2 \times \Delta f_{\text{OBUE}}$ the <i>limit</i> within the <i>Inter RF Bandwidth gaps</i> is calculated as a cumulative sum of contributions from adjacent <i>sub-blocks</i> or <i>Base Station RF Bandwidth</i> on each side of the <i>Inter RF Bandwidth gap</i>.</p> <p>NOTE 3: The requirement is not applicable when $\Delta f_{\text{max}} < 10$ MHz.</p>			

Table 4.3.13.2.1.2-7: Local Area BS operating band unwanted emissions limits for BC1 for bands ≤ 3 GHz

Frequency offset of measurement filter -3 dB point, Δf	Frequency offset of measurement filter centre frequency, f_{offset}	Limit (notes 1 and 2)	Measurement bandwidth
$0 \text{ MHz} \leq \Delta f < 5 \text{ MHz}$	$0,05 \text{ MHz} \leq f_{\text{offset}} < 5,05 \text{ MHz}$	$-19,2 \text{ dBm} - 7/5(f_{\text{offset}}/\text{MHz} - 0,05) \text{ dB}$	100 kHz
$5 \text{ MHz} \leq \Delta f < \min(10 \text{ MHz}, \Delta f_{\text{max}})$	$5,05 \text{ MHz} \leq f_{\text{offset}} < \min(10,05 \text{ MHz}, f_{\text{offset}_{\text{max}}})$	-26,2 dBm	100 kHz
$10 \text{ MHz} \leq \Delta f \leq \Delta f_{\text{max}}$	$10,05 \text{ MHz} \leq f_{\text{offset}} < f_{\text{offset}_{\text{max}}}$	-28 dBm (note 3)	100 kHz
NOTE 1: For a RIB supporting <i>non-contiguous spectrum</i> operation within any <i>operating band</i> the <i>limit</i> within <i>sub-block gaps</i> is calculated as a cumulative sum of contributions from adjacent sub-blocks on each side of the <i>sub-block gap</i> . Exception is $\Delta f \geq 10$ MHz from both adjacent sub-blocks on each side of the <i>sub-block gap</i> , where the <i>limit</i> within <i>sub-block gaps</i> shall be -28 dBm/100 kHz.			
NOTE 2: For a <i>multi-band RIB</i> with <i>Inter RF Bandwidth gap</i> $< 2 \times \Delta f_{\text{OBUE}}$ MHz the <i>limit</i> within the <i>Inter RF Bandwidth gaps</i> is calculated as a cumulative sum of contributions from adjacent <i>sub-blocks</i> on each side of the <i>Inter RF Bandwidth gap</i> .			
NOTE 3: The requirement is not applicable when $\Delta f_{\text{max}} < 10$ MHz.			

Table 4.3.13.2.1.2-8: Local Area BS operating band unwanted emissions limits for BC1 for bands > 3 GHz

Frequency offset of measurement filter -3 dB point, Δf	Frequency offset of measurement filter centre frequency, f_{offset}	Limit (notes 1 and 2)	Measurement bandwidth
$0 \text{ MHz} \leq \Delta f < 5 \text{ MHz}$	$0,05 \text{ MHz} \leq f_{\text{offset}} < 5,05 \text{ MHz}$	$-19 \text{ dBm} - 7/5(f_{\text{offset}}/\text{MHz} - 0,05) \text{ dB}$	100 kHz
$5 \text{ MHz} \leq \Delta f < \min(10 \text{ MHz}, \Delta f_{\text{max}})$	$5,05 \text{ MHz} \leq f_{\text{offset}} < \min(10,05 \text{ MHz}, f_{\text{offset}_{\text{max}}})$	-26 dBm	100 kHz
$10 \text{ MHz} \leq \Delta f \leq \Delta f_{\text{max}}$	$10,05 \text{ MHz} \leq f_{\text{offset}} < f_{\text{offset}_{\text{max}}}$	-28 dBm (note 3)	100 kHz
NOTE 1: For a RIB supporting <i>non-contiguous spectrum</i> operation within any <i>operating band</i> the <i>limit</i> within <i>sub-block gaps</i> is calculated as a cumulative sum of contributions from adjacent sub-blocks on each side of the <i>sub-block gap</i> . Exception is $\Delta f \geq 10$ MHz from both adjacent sub-blocks on each side of the <i>sub-block gap</i> , where the <i>limit</i> within <i>sub-block gaps</i> shall be -28 dBm/100 kHz.			
NOTE 2: For a <i>multi-band RIB</i> with <i>Inter RF Bandwidth gap</i> $< 2 \times \Delta f_{\text{OBUE}}$ MHz the <i>limit</i> within the <i>Inter RF Bandwidth gaps</i> is calculated as a cumulative sum of contributions from adjacent <i>sub-blocks</i> on each side of the <i>Inter RF Bandwidth gap</i> .			
NOTE 3: The requirement is not applicable when $\Delta f_{\text{max}} < 10$ MHz.			

4.3.13.2.1.3 Band Category 2

For a *RIB* operating in Band Category 2 the requirement applies outside the *Base Station RF Bandwidth edges*. In addition, for a *RIB* operating in *non-contiguous spectrum*, it applies inside any *sub-block gap*.

Outside the *Base Station RF Bandwidth edges*, emissions shall not exceed the limits specified in tables below, where:

- Δf is the separation between the *Base Station RF Bandwidth edge* frequency and the nominal -3 dB point of the measuring filter closest to the carrier frequency.
- f_{offset} is the separation between the *Base Station RF Bandwidth edge* frequency and the centre of the measuring filter.
- $f_{\text{offset}_{\text{max}}}$ is the offset to the frequency Δf_{OBUE} MHz outside the downlink *operating band*.
- Δf_{max} is equal to $f_{\text{offset}_{\text{max}}}$ minus half of the bandwidth of the measuring filter.

For a *multi-band RIB*, inside any *Inter RF Bandwidth gaps* with $W_{\text{gap}} < 2 \times \Delta f_{\text{OBUE}}$ MHz, emissions shall not exceed the cumulative sum of the limits specified at the *Base Station RF Bandwidth edges* on each side of the *Inter RF Bandwidth gap*. The *limit* for *Base Station RF Bandwidth edge* is specified in tables below, where in this case:

- Δf is the separation between the *Base Station RF Bandwidth edge* frequency and the nominal -3 dB point of the measuring filter closest to the carrier frequency.

- f_{offset} is the separation between the *Base Station RF Bandwidth edge* frequency and the centre of the measuring filter.
- $f_{\text{offset}_{\text{max}}}$ is equal to the *Inter RF Bandwidth gap* divided by two.
- Δf_{max} is equal to $f_{\text{offset}_{\text{max}}}$ minus half of the bandwidth of the measuring filter.

For a *multi-band RIB* and where there is no carrier transmitted in an *operating band*, no cumulative limits are applied in the *inter-band gap* between a supported downlink band with carrier(s) transmitted and a supported downlink band without any carrier transmitted; and:

- In case the *inter-band gap* between a supported downlink band with carrier(s) transmitted and a supported downlink band without any carrier transmitted less than is $2 \times \Delta f_{\text{OBUE}}$ MHz, $f_{\text{offset}_{\text{max}}}$ shall be the offset to the frequency Δf_{OBUE} MHz outside the outermost edges of the two supported downlink *operating bands* and the *operating band unwanted emission* limit of the band where there are carriers transmitted, as defined in the tables of the present clause, shall apply across both supported downlink bands.
- In other cases, the *operating band unwanted emission* limit of the band where there are carriers transmitted, as defined in the tables of the present clause for the largest frequency offset (Δf_{max}), shall apply from Δf_{OBUE} MHz below the lowest frequency, up to Δf_{OBUE} MHz above the highest frequency of the supported downlink *operating band* without any carrier transmitted.

For a multicarrier *single-band RIB* or a *single-band RIB* configured for intra-band contiguous or non-contiguous carrier aggregation, the definitions above apply to the lower edge of the carrier transmitted at the lowest carrier frequency and the upper edge of the carrier transmitted at the highest carrier frequency within a specified frequency band.

Inside any *sub-block gap* for a *RIB* operating in *non-contiguous spectrum*, emissions shall not exceed the cumulative sum of the limit specified for the adjacent sub-blocks on each side of the *sub-block gap*. The *limit* for each sub-block is specified in tables below, where in this case:

- Δf is the separation between the sub-block edge frequency and the nominal -3 dB point of the measuring filter closest to the sub-block edge.
- f_{offset} is the separation between the sub-block edge frequency and the centre of the measuring filter.
- $f_{\text{offset}_{\text{max}}}$ is equal to the *sub-block gap* bandwidth divided by two.
- Δf_{max} is equal to $f_{\text{offset}_{\text{max}}}$ minus half of the bandwidth of the measuring filter.

Table 4.3.13.2.1.3-1: Wide Area BS operating band unwanted emissions limits for BC2, except those covered by tables 4.3.13.2.1.3-1a and 4.3.13.2.1.3-1b

Frequency offset of measurement filter -3 dB point, Δf	Frequency offset of measurement filter centre frequency, f_{offset}	Limit (notes 2 and 3)	Measurement bandwidth
$0 \text{ MHz} \leq \Delta f < 0,2 \text{ MHz}$ (note 1)	$0,015 \text{ MHz} \leq f_{\text{offset}} < 0,215 \text{ MHz}$	-3,2 dBm	30 kHz
$0,2 \text{ MHz} \leq \Delta f < 1 \text{ MHz}$	$0,215 \text{ MHz} \leq f_{\text{offset}} < 1,015 \text{ MHz}$	$-3,2-15(f_{\text{offset}}/\text{MHz}-0,215) \text{ dBm}$	30 kHz
(note 4)	$1,015 \text{ MHz} \leq f_{\text{offset}} < 1,5 \text{ MHz}$	-15,2 dBm	30 kHz
$1 \text{ MHz} \leq \Delta f \leq \min(\Delta f_{\text{max}}, 10 \text{ MHz})$	$1,5 \text{ MHz} \leq f_{\text{offset}} < \min(f_{\text{offset}_{\text{max}}}, 10,5 \text{ MHz})$	-2,2 dBm	1 MHz
$10 \text{ MHz} \leq \Delta f \leq \Delta f_{\text{max}}$	$10,5 \text{ MHz} \leq f_{\text{offset}} < f_{\text{offset}_{\text{max}}}$	-6 dBm (note 5)	1 MHz
NOTE 1: For operation with an E-UTRA 1,4 or 3 MHz carrier adjacent to the <i>Base Station RF Bandwidth edge</i> or the sub-block edge, the limits in table 4.3.13.2.1.3-2 apply for $0 \text{ MHz} \leq \Delta f < 0,15 \text{ MHz}$.			
NOTE 2: For a RIB supporting <i>non-contiguous spectrum</i> operation within any <i>operating band</i> the <i>limit</i> within <i>sub-block gaps</i> is calculated as a cumulative sum of contributions from adjacent sub-blocks on each side of the <i>sub-block gap</i> , where the contribution from the far-end <i>sub-block</i> shall be scaled according to the <i>measurement bandwidth</i> of the near-end <i>sub-block</i> . Exception is $\Delta f \geq 10 \text{ MHz}$ from both adjacent sub-blocks on each side of the <i>sub-block gap</i> , where the <i>limit</i> within <i>sub-block gaps</i> shall be -6 dBm/MHz.			
NOTE 3: For a <i>multi-band RIB</i> with <i>Inter RF Bandwidth gap</i> $< 2 \times \Delta f_{\text{OBUe}}$ MHz operation the <i>limit</i> within the <i>Inter RF Bandwidth gaps</i> is calculated as a cumulative sum of contributions from adjacent <i>sub-blocks</i> on each side of the <i>Inter RF Bandwidth gap</i> , where the contribution from the far-end sub-block or <i>Base Station RF Bandwidth</i> shall be scaled according to the measurement bandwidth of the near-end sub-block or <i>Base Station RF Bandwidth</i> .			
NOTE 4: This frequency range ensures that the range of values of f_{offset} is continuous.			
NOTE 5: The requirement is not applicable when $\Delta f_{\text{max}} < 10 \text{ MHz}$.			

Table 4.3.13.2.1.3-1a: Wide Area BS operating band unwanted emissions limits for BC2, for bands $\leq 1 \text{ GHz}$, for BS supporting NR (except for BS operating in band 8) and not supporting UTRA

Frequency offset of measurement filter -3 dB point, Δf	Frequency offset of measurement filter centre frequency, f_{offset}	Limit (notes 1 and 2)	Measurement bandwidth
$0 \text{ MHz} \leq \Delta f < 5 \text{ MHz}$	$0,05 \text{ MHz} \leq f_{\text{offset}} < 5,05 \text{ MHz}$	$3,8 \text{ dBm} - 7/5(f_{\text{offset}}/\text{MHz} - 0,05)\text{dB}$	100 kHz
$5 \text{ MHz} \leq \Delta f < \min(10 \text{ MHz}, \Delta f_{\text{max}})$	$5,05 \text{ MHz} \leq f_{\text{offset}} < \min(10,05 \text{ MHz}, f_{\text{offset}_{\text{max}}})$	-3,2 dBm	100 kHz
$10 \text{ MHz} \leq \Delta f \leq \Delta f_{\text{max}}$	$10,05 \text{ MHz} \leq f_{\text{offset}} < f_{\text{offset}_{\text{max}}}$	-7 dBm (note 4)	100 kHz
NOTE 1: For a RIB supporting <i>non-contiguous spectrum</i> operation within any <i>operating band</i> , the limit within <i>sub-block gaps</i> is calculated as a cumulative sum of contributions from adjacent sub-blocks on each side of the <i>sub-block gap</i> . Exception is $\Delta f \geq 10 \text{ MHz}$ from both adjacent sub-blocks on each side of the <i>sub-block gap</i> , where the limit within <i>sub-block gaps</i> shall be -7 dBm/100 kHz.			
NOTE 2: For a <i>multi-band RIB</i> with <i>Inter RF Bandwidth gap</i> $< 2 \times \Delta f_{\text{OBUe}}$ the limit within the <i>Inter RF Bandwidth gaps</i> is calculated as a cumulative sum of contributions from adjacent <i>sub-blocks</i> or <i>Base Station RF Bandwidth</i> on each side of the <i>Inter RF Bandwidth gap</i> .			
NOTE 3: For operation with an E-UTRA 1,4 or 3 MHz carrier adjacent to the <i>Base Station RF Bandwidth edge</i> or the sub-block edge, the limits in table 4.3.13.2.1.3-2 apply for $0 \text{ MHz} \leq \Delta f < 0,15 \text{ MHz}$.			
NOTE 4: The requirement is not applicable when $\Delta f_{\text{max}} < 10 \text{ MHz}$.			

Table 4.3.13.2.1.3-1b: Wide Area BS operating band unwanted emissions limits for BC2 for bands > 1 GHz, for BS supporting NR (except for BS operating in band 3) and not supporting UTRA

Frequency offset of measurement filter -3 dB point, Δf	Frequency offset of measurement filter centre frequency, f_{offset}	Limit (notes 1 and 2)	Measurement bandwidth
$0 \text{ MHz} \leq \Delta f < 5 \text{ MHz}$	$0,05 \text{ MHz} \leq f_{\text{offset}} < 5,05 \text{ MHz}$	$3,8 \text{ dBm} - 7/5(f_{\text{offset}}/\text{MHz} - 0,05)\text{dB}$	100 kHz
$5 \text{ MHz} \leq \Delta f < \min(10 \text{ MHz}, \Delta f_{\text{max}})$	$5,05 \text{ MHz} \leq f_{\text{offset}} < \min(10,05 \text{ MHz}, f_{\text{offset}_{\text{max}}})$	-3,2 dBm	100 kHz
$10 \text{ MHz} \leq \Delta f \leq \Delta f_{\text{max}}$	$10,5 \text{ MHz} \leq f_{\text{offset}} < f_{\text{offset}_{\text{max}}}$	-7 dBm (note 4)	1 MHz
NOTE 1: For a RIB supporting <i>non-contiguous spectrum</i> operation within any <i>operating band</i> , the limit within <i>sub-block gaps</i> is calculated as a cumulative sum of contributions from adjacent sub-blocks on each side of the <i>sub-block gap</i> . Exception is $\Delta f \geq 10 \text{ MHz}$ from both adjacent sub-blocks on each side of the <i>sub-block gap</i> , where the limit within <i>sub-block gaps</i> shall be -6 dBm/MHz.			
NOTE 2: For a <i>multi-band RIB</i> with <i>Inter RF Bandwidth gap</i> $< 2 \times \Delta f_{\text{OBUE}}$ the limit within the <i>Inter RF Bandwidth gaps</i> is calculated as a cumulative sum of contributions from adjacent <i>sub-blocks</i> or <i>Base Station RF Bandwidth</i> on each side of the <i>Inter RF Bandwidth gap</i> .			
NOTE 3: For operation with an E-UTRA 1,4 or 3 MHz carrier adjacent to the <i>Base Station RF Bandwidth</i> edge or the <i>sub-block edge</i> , the limits in Table 4.3.13.2.1.3-2 apply for $0 \text{ MHz} \leq \Delta f < 0,15 \text{ MHz}$.			
NOTE 4: The requirement is not applicable when $\Delta f_{\text{max}} < 10 \text{ MHz}$.			

Table 4.3.13.2.1.3-2: Wide Area BS operating band unwanted emissions limits for operation in BC2 with E-UTRA 1,4 or 3 MHz carriers adjacent to the *Base Station RF Bandwidth* edge or the *sub-block edge*

Frequency offset of measurement filter -3 dB point, Δf	Frequency offset of measurement filter centre frequency, f_{offset}	Limit (notes 2 and 3)	Measurement bandwidth
$0 \text{ MHz} \leq \Delta f < 0,05 \text{ MHz}$	$0,015 \text{ MHz} \leq f_{\text{offset}} < 0,065 \text{ MHz}$	$\text{Max}(15,8 \text{ dBm} - 60(f_{\text{offset}}/\text{MHz} - 0,015), -3,2 \text{ dBm})$	30 kHz
$0,05 \text{ MHz} \leq \Delta f < 0,15 \text{ MHz}$	$0,065 \text{ MHz} \leq f_{\text{offset}} < 0,165 \text{ MHz}$	$\text{Max}(12,8 \text{ dBm} - 160(f_{\text{offset}}/\text{MHz} - 0,065), -3,2 \text{ dBm})$	30 kHz
NOTE 1: The limits in this table only apply for operation with an E-UTRA 1,4 or 3 MHz carrier adjacent to the <i>Base Station RF Bandwidth</i> edge or the <i>sub-block edge</i> .			
NOTE 2: For a RIB supporting <i>non-contiguous spectrum</i> operation within any <i>operating band</i> the <i>limit</i> within <i>sub-block gaps</i> is calculated as a cumulative sum of contributions from adjacent sub-blocks on each side of the <i>sub-block gap</i> .			
NOTE 3: For a <i>multi-band RIB</i> with <i>Inter RF Bandwidth gap</i> $< 2 \times \Delta f_{\text{OBUE}}$ MHz the <i>limit</i> within the <i>Inter RF Bandwidth gaps</i> is calculated as a cumulative sum of contributions from adjacent <i>sub-blocks</i> on each side of the <i>Inter RF Bandwidth gap</i> .			

Table 4.3.13.2.1.3-3: Medium Range BS operating band unwanted emissions limits for BC2, 40 dBm < P_{rated,c,TRP} ≤ 47 dBm for BS not supporting NR

Frequency offset of measurement filter -3 dB point, Δf	Frequency offset of measurement filter centre frequency, f _{offset}	Limit (notes 2 and 3)	Measurement bandwidth
0 MHz ≤ Δf < 0,6 MHz (note 1)	0,015 MHz ≤ f _{offset} < 0,615 MHz	P _{rated,c,TRP} -56,2 dB-(5/3)×(f _{offset} -0,015) dB	30 kHz
0,6 MHz ≤ Δf < 1 MHz (note 4)	0,615 MHz ≤ f _{offset} < 1,015 MHz	P _{rated,c,TRP} -51,2 dB-15×(f _{offset} -0,215) dB	30 kHz
	1,015 MHz ≤ f _{offset} < 1,5 MHz	P _{rated,c,TRP} - 63,2 dB	30 kHz
1 MHz ≤ Δf ≤ 2,8 MHz	1,5 MHz ≤ f _{offset} < 3,3 MHz	P _{rated,c,TRP} - 50,2 dB	1 MHz
2,8 MHz ≤ Δf ≤ 5 MHz	3,3 MHz ≤ f _{offset} < 5,5 MHz	min(P _{rated,c,TRP} - 50,2 dB, -4,2 dBm)	1 MHz
5 MHz ≤ Δf ≤ min(Δf _{max} , 10 MHz)	5,5 MHz ≤ f _{offset} < min(f _{offset} _{max} , 10,5 MHz)	P _{rated,c,TRP} - 54,2 dB	1 MHz
10 MHz ≤ Δf ≤ Δf _{max}	10,5 MHz ≤ f _{offset} < f _{offset} _{max}	P _{rated,c,TRP} -56 dB (note 5)	1 MHz

NOTE 1: For operation with an E-UTRA 1,4 or 3 MHz carrier adjacent to the *Base Station RF Bandwidth edge* or the sub-block edge, the limits in table 4.3.13.2.1.3-5 apply for 0 MHz ≤ Δf < 0,15 MHz.

NOTE 2: For a RIB supporting *non-contiguous spectrum* operation within any *operating band* the *limit* within *sub-block gaps* is calculated as a cumulative sum of contributions from adjacent sub-blocks on each side of the *sub-block gap*, where the contribution from the far-end *sub-block* shall be scaled according to the *measurement bandwidth* of the near-end *sub-block*. Exception is Δf ≥ 10 MHz from both adjacent sub-blocks on each side of the *sub-block gap*, where the *limit* within *sub-block gaps* shall be (P_{rated,c,TRP} - 56 dB)/MHz.

NOTE 3: For a *multi-band RIB* with *Inter RF Bandwidth gap* < 2 × Δf_{OBUE} MHz the *limit* within the *Inter RF Bandwidth gaps* is calculated as a cumulative sum of contributions from adjacent *sub-blocks* on each side of the *Inter RF Bandwidth gap*, where the contribution from the far-end sub-block or *Base Station RF Bandwidth* shall be scaled according to the measurement bandwidth of the near-end sub-block or *Base Station RF Bandwidth*.

NOTE 4: This frequency range ensures that the range of values of f_{offset} is continuous.

NOTE 5: The requirement is not applicable when Δf_{max} < 10 MHz.

Table 4.3.13.2.1.3-3a: Medium Range BS operating band unwanted emissions limits for BS supporting NR and not supporting UTRA in BC2 bands, BS maximum output power 40 dBm < P_{rated,c,TRP} ≤ 47 dBm

Frequency offset of measurement filter -3 dB point, Δf	Frequency offset of measurement filter centre frequency, f _{offset}	Limit (notes 1 and 2)	Measurement bandwidth
0 MHz ≤ Δf < 5 MHz	0,05 MHz ≤ f _{offset} < 5,05 MHz	P _{rated,c,TRP} - 51,2 dB - 7/5(f _{offset} /MHz - 0,05) dB	100 kHz
5 MHz ≤ Δf < min(10 MHz, Δf _{max})	5,05 MHz ≤ f _{offset} < min(10,05 MHz, f _{offset} _{max})	P _{rated,c,TRP} -58,2 dB	100 kHz
10 MHz ≤ Δf ≤ Δf _{max}	10,05 MHz ≤ f _{offset} < f _{offset} _{max}	Min(P _{rated,c,TRP} -60 dB, -16 dBm) (note 4)	100 kHz

NOTE 1: For a RIB supporting *non-contiguous spectrum* operation within any *operating band* the limit within *sub-block gaps* is calculated as a cumulative sum of contributions from adjacent sub-blocks on each side of the *sub-block gap*. Exception is Δf ≥ 10 MHz from both adjacent sub-blocks on each side of the *sub-block gap*, where the limit within *sub-block gaps* shall be Min(P_{rated,c,TRP} -60 dB, -16 dBm)/100 kHz.

NOTE 2: For a *multi-band RIB* with *Inter RF Bandwidth gap* < 2 × Δf_{OBUE} the limit within the *Inter RF Bandwidth gaps* is calculated as a cumulative sum of contributions from adjacent *sub-blocks* or *Base Station RF Bandwidth* on each side of the *Inter RF Bandwidth gap*.

NOTE 3: For operation with an E-UTRA 1,4 or 3 MHz carrier adjacent to the *Base Station RF Bandwidth edge* or the sub-block edge, the limits in table 4.3.13.2.1.3-5 apply for 0 MHz ≤ Δf < 0,15 MHz.

NOTE 4: The requirement is not applicable when Δf_{max} < 10 MHz.

Table 4.3.13.2.1.3-4: Medium Range BS operating band unwanted emissions limits for BC2, $P_{\text{rated,c,TRP}} \leq 40$ dBm for BS not supporting NR

Frequency offset of measurement filter -3 dB point, Δf	Frequency offset of measurement filter centre frequency, f_{offset}	Limit (notes 2 and 3)	Measurement bandwidth
$0 \text{ MHz} \leq \Delta f < 0,6 \text{ MHz}$ (note 1)	$0,015 \text{ MHz} \leq f_{\text{offset}} < 0,615 \text{ MHz}$	-16,2 dBm-5/3(f_{offset} /MHz-0,015)dB	30 kHz
$0,6 \text{ MHz} \leq \Delta f < 1 \text{ MHz}$ (note 4)	$0,615 \text{ MHz} \leq f_{\text{offset}} < 1,015 \text{ MHz}$	-11,2 dBm-15(f_{offset} /MHz-0,215)dB	30 kHz
$1 \text{ MHz} \leq \Delta f \leq 5 \text{ MHz}$	$1,015 \text{ MHz} \leq f_{\text{offset}} < 1,5 \text{ MHz}$	-23,2 dBm	30 kHz
$5 \text{ MHz} \leq \Delta f \leq \min(\Delta f_{\text{max}}, 10 \text{ MHz})$	$1,5 \text{ MHz} \leq f_{\text{offset}} < 5,5 \text{ MHz}$	-10,2 dBm	1 MHz
$10 \text{ MHz} \leq \Delta f \leq \Delta f_{\text{max}}$	$5,5 \text{ MHz} \leq f_{\text{offset}} < \min(f_{\text{offset}_{\text{max}}}, 10,5 \text{ MHz})$	-14,2 dBm	1 MHz
	$10,5 \text{ MHz} \leq f_{\text{offset}} < f_{\text{offset}_{\text{max}}}$	-16 dBm (note 5)	1 MHz

NOTE 1: For operation with an E-UTRA 1,4 or 3 MHz carrier adjacent to the *Base Station RF Bandwidth edge* or the sub-block edge, the limits in table 4.3.13.2.1.3-6 apply for $0 \text{ MHz} \leq \Delta f < 0,15 \text{ MHz}$.

NOTE 2: For a RIB supporting *non-contiguous spectrum* operation within any *operating band* the *limit* within *sub-block gaps* is calculated as a cumulative sum of contributions from adjacent sub-blocks on each side of the *sub-block gap*, where the contribution from the far-end *sub-block* shall be scaled according to the *measurement bandwidth* of the near-end *sub-block*. Exception is $\Delta f \geq 10 \text{ MHz}$ from both adjacent sub-blocks on each side of the *sub-block gap*, where the *limit* within *sub-block gaps* shall be -16 dBm/MHz.

NOTE 3: For a *multi-band RIB* with *Inter RF Bandwidth gap* $< 2 \times \Delta f_{\text{OBUE}}$ MHz the *limit* within the *Inter RF Bandwidth gaps* is calculated as a cumulative sum of contributions from adjacent *sub-blocks* on each side of the *Inter RF Bandwidth gap*, where the contribution from the far-end sub-block or *Base Station RF Bandwidth* shall be scaled according to the measurement bandwidth of the near-end sub-block or *Base Station RF Bandwidth*.

NOTE 4: This frequency range ensures that the range of values of f_{offset} is continuous.

NOTE 5: The requirement is not applicable when $\Delta f_{\text{max}} < 10 \text{ MHz}$.

Table 4.3.13.2.1.3-4a: Medium Range BS operating band unwanted emissions limits for BS supporting NR and not supporting UTRA in BC2 bands, BS maximum output power $P_{\text{rated,c,TRP}} \leq 40$ dBm

Frequency offset of measurement filter -3 dB point, Δf	Frequency offset of measurement filter centre frequency, f_{offset}	Limit (notes 1 and 2)	Measurement bandwidth
$0 \text{ MHz} \leq \Delta f < 5 \text{ MHz}$	$0,05 \text{ MHz} \leq f_{\text{offset}} < 5,05 \text{ MHz}$	-11,2 dBm - 7/5(f_{offset} /MHz-0,05) dB	100 kHz
$5 \text{ MHz} \leq \Delta f < \min(10 \text{ MHz}, \Delta f_{\text{max}})$	$5,05 \text{ MHz} \leq f_{\text{offset}} < \min(10,05 \text{ MHz}, f_{\text{offset}_{\text{max}}})$	-18,2 dBm	100 kHz
$10 \text{ MHz} \leq \Delta f \leq \Delta f_{\text{max}}$	$10,05 \text{ MHz} \leq f_{\text{offset}} < f_{\text{offset}_{\text{max}}}$	-20 dBm (note 4)	100 kHz

NOTE 1: For a RIB supporting *non-contiguous spectrum* operation within any *operating band* the *limit* within *sub-block gaps* is calculated as a cumulative sum of contributions from adjacent sub-blocks on each side of the *sub-block gap*. Exception is $\Delta f \geq 10 \text{ MHz}$ from both adjacent sub-blocks on each side of the *sub-block gap*, where the *limit* within *sub-block gaps* shall be -20 dBm/100 kHz.

NOTE 2: For a *multi-band RIB* with *Inter RF Bandwidth gap* $< 2 \times \Delta f_{\text{OBUE}}$ the *limit* within the *Inter RF Bandwidth gaps* is calculated as a cumulative sum of contributions from adjacent *sub-blocks* or *Base Station RF Bandwidth* on each side of the *Inter RF Bandwidth gap*.

NOTE 3: For operation with an E-UTRA 1,4 or 3 MHz carrier adjacent to the *Base Station RF Bandwidth edge* or the sub-block edge, the limits in table 4.3.13.2.1.3-6 apply for $0 \text{ MHz} \leq \Delta f < 0,15 \text{ MHz}$.

NOTE 4: The requirement is not applicable when $\Delta f_{\text{max}} < 10 \text{ MHz}$.

Table 4.3.13.2.1.3-5: Medium Range operating band unwanted emissions limits for operation in BC2 with E-UTRA 1,4 or 3 MHz carriers adjacent to the *Base Station RF Bandwidth edge* or the sub-block edge, $40 \text{ dBm} < P_{\text{rated,c,TRP}} \leq 47 \text{ dBm}$

Frequency offset of measurement filter -3 dB point, Δf	Frequency offset of measurement filter centre frequency, f_{offset}	Limit (notes 2 and 3)	Measurement bandwidth
$0 \text{ MHz} \leq \Delta f < 0,05 \text{ MHz}$	$0,015 \text{ MHz} \leq f_{\text{offset}} < 0,065 \text{ MHz}$	$P_{\text{rated,c,TRP}} - 36,2 - 60(f_{\text{offset}} - 0,015)$	30 kHz
$0,05 \text{ MHz} \leq \Delta f < 0,15 \text{ MHz}$	$0,065 \text{ MHz} \leq f_{\text{offset}} < 0,165 \text{ MHz}$	$P_{\text{rated,c,TRP}} - 39,2 - 160(f_{\text{offset}} - 0,065)$	30 kHz

NOTE 1: The limits in this table only apply for operation with an E-UTRA 1,4 or 3 MHz carrier adjacent to the *Base Station RF Bandwidth edge* or the sub-block edge.

NOTE 2: For a RIB supporting *non-contiguous spectrum* operation within any *operating band* the *limit* within *sub-block gaps* is calculated as a cumulative sum of contributions from adjacent sub-blocks on each side of the *sub-block gap*.

NOTE 3: For a *multi-band RIB* with *Inter RF Bandwidth gap* $< 2 \times \Delta f_{\text{OBUE}}$ MHz the *limit* within the *Inter RF Bandwidth gaps* is calculated as a cumulative sum of contributions from adjacent *sub-blocks* on each side of the *Inter RF Bandwidth gap*.

Table 4.3.13.2.1.3-6: Medium Range operating band unwanted emissions limits for operation in BC2 with E-UTRA 1,4 or 3 MHz carriers adjacent to the *Base Station RF Bandwidth edge* or the sub-block edge, $P_{\text{rated,c,TRP}} \leq 40 \text{ dBm}$

Frequency offset of measurement filter -3 dB point, Δf	Frequency offset of measurement filter centre frequency, f_{offset}	Limit (notes 2 and 3)	Measurement bandwidth
$0 \text{ MHz} \leq \Delta f < 0,05 \text{ MHz}$	$0,015 \text{ MHz} \leq f_{\text{offset}} < 0,065 \text{ MHz}$	$\text{Max}(3,8 - 60(f_{\text{offset}}/\text{MHz} - 0,015), -16,2) \text{ dBm}$	30 kHz
$0,05 \text{ MHz} \leq \Delta f < 0,15 \text{ MHz}$	$0,065 \text{ MHz} \leq f_{\text{offset}} < 0,165 \text{ MHz}$	$\text{Max}(0,8 - 160(f_{\text{offset}}/\text{MHz} - 0,065), -16,2) \text{ dBm}$	30 kHz

NOTE 1: The limits in this table only apply for operation with an E-UTRA 1,4 or 3 MHz carrier adjacent to the *Base Station RF Bandwidth edge* or the sub-block edge.

NOTE 2: For a RIB supporting *non-contiguous spectrum* operation within any *operating band* the *limit* within *sub-block gaps* is calculated as a cumulative sum of contributions from adjacent sub-blocks on each side of the *sub-block gap*.

NOTE 3: For a *multi-band RIB* with *Inter RF Bandwidth gap* $< 2 \times \Delta f_{\text{OBUE}}$ MHz the *limit* within the *Inter RF Bandwidth gaps* is calculated as a cumulative sum of contributions from adjacent *sub-blocks* on each side of the *Inter RF Bandwidth gap*.

Table 4.3.13.2.1.3-7: Local Area operating band unwanted emissions limits for BC2

Frequency offset of measurement filter -3 dB point, Δf	Frequency offset of measurement filter centre frequency, f_{offset}	Limit (notes 2 and 3)	Measurement bandwidth
$0 \text{ MHz} \leq \Delta f < 5 \text{ MHz}$ (note 1)	$0,05 \text{ MHz} \leq f_{\text{offset}} < 5,05 \text{ MHz}$	$-19,2 - 7/5(f_{\text{offset}}/\text{MHz} - 0,05) \text{ dBm}$	100 kHz
$5 \text{ MHz} \leq \Delta f < \min(10 \text{ MHz}, \Delta f_{\text{max}})$	$5,05 \text{ MHz} \leq f_{\text{offset}} < \min(10,05 \text{ MHz}, f_{\text{offset}_{\text{max}}})$	-26,2 dBm	100 kHz
$10 \text{ MHz} \leq \Delta f \leq \Delta f_{\text{max}}$	$10,05 \text{ MHz} \leq f_{\text{offset}} < f_{\text{offset}_{\text{max}}}$	-28 dBm (note 4)	100 kHz

NOTE 1: For operation with an E-UTRA 1,4 or 3 MHz carrier adjacent to the *Base Station RF Bandwidth edge* or the sub-block edge, the limits in table 4.3.13.2.1.3-8 apply for $0 \text{ MHz} \leq \Delta f < 0,16 \text{ MHz}$.

NOTE 2: For a RIB supporting *non-contiguous spectrum* operation within any *operating band* the *limit* within *sub-block gaps* is calculated as a cumulative sum of contributions from adjacent sub-blocks on each side of the *sub-block gap*. Exception is $\Delta f \geq 10 \text{ MHz}$ from both adjacent sub-blocks on each side of the *sub-block gap*, where the *limit* within *sub-block gaps* shall be -28 dBm/100 kHz.

NOTE 3: For a *multi-band RIB* with *Inter RF Bandwidth gap* $< 2 \times \Delta f_{\text{OBUE}}$ MHz the *limit* within the *Inter RF Bandwidth gaps* is calculated as a cumulative sum of contributions from adjacent *sub-blocks* on each side of the *Inter RF Bandwidth gap*.

NOTE 4: The requirement is not applicable when $\Delta f_{\text{max}} < 10 \text{ MHz}$.

Table 4.3.13.2.1.3-8: Local Area operating band unwanted emissions limits for operation in BC2 with E-UTRA 1,4 or 3 MHz carriers adjacent to the *Base Station RF Bandwidth edge* or the sub-block edge

Frequency offset of measurement filter -3 dB point, Δf	Frequency offset of measurement filter centre frequency, f_{offset}	Limit (notes 2 and 3)	Measurement bandwidth
$0 \text{ MHz} \leq \Delta f < 0,05 \text{ MHz}$	$0,015 \text{ MHz} \leq f_{\text{offset}} < 0,065 \text{ MHz}$	Max(-3,2 dBm-60(f_{offset} /MHz-0,015)dB, -24,2 dBm)	30 kHz
$0,05 \text{ MHz} \leq \Delta f < 0,16 \text{ MHz}$	$0,065 \text{ MHz} \leq f_{\text{offset}} < 0,175 \text{ MHz}$	max(-6,2 dBm-160(f_{offset} /MHz-0,065)dB, -24,2 dBm)	30 kHz

NOTE 1: The limits in this table only apply for operation with an E-UTRA 1,4 or 3 MHz carrier adjacent to the *Base Station RF Bandwidth edge* or the sub-block edge.

NOTE 2: For a RIB supporting *non-contiguous spectrum* operation within any *operating band* the *limit* within *sub-block gaps* is calculated as a cumulative sum of contributions from adjacent sub-blocks on each side of the *sub-block gap*.

NOTE 3: For a *multi-band RIB* with *Inter RF Bandwidth gap* $< 2 \times \Delta f_{\text{OBUe}}$ MHz the *limit* within the *Inter RF Bandwidth gaps* is calculated as a cumulative sum of contributions from adjacent *sub-blocks* on each side of the *Inter RF Bandwidth gap*.

4.3.13.2.1.4 Additional requirements

For co-existence with FSS/FS the emissions for BS operating in bands 77 and 78, shall not exceed the limits specified in table 4.3.13.2.1.4-1.

Table 4.3.13.2.1.4-1: Additional operating band unwanted emissions limits for bands 77 and 78

Frequency range	Limit	Measurement bandwidth
3 800 MHz to 3 805 MHz	Min($P_{\text{rated,t,TRP}} - 40, 16$) dBm	5 MHz
3 805 MHz to 3 810 MHz	Min($P_{\text{rated,t,TRP}} - 43, 12$) dBm	5 MHz
3 810 MHz to 3 840 MHz	Min $P_{\text{rated,t,TRP}} - 43, 1$) dBm	5 MHz
Above 3 840 MHz	-14 dBm	5 MHz

For BS operating in Band 32 within 1 452 - 1 492 MHz, in Band 75 within 1 432 - 1 517 MHz and in Band 76 within 1427-1432 MHz the maximum level of unwanted emissions, measured as EIRP, on centre frequencies f_{offset} and with filter bandwidth according to table 4.3.13.2.1.4-2, shall not exceed the EIRP limits indicated in the table.

For BS operating in Band 32, this requirement applies in the frequency range 1 452 - 1 492 MHz, while it applies also within 1 427 - 1 452 MHz and/or 1 492 - 1 517 MHz, even though part of the ranges falls in the spurious domain. For Band 75, this requirement applies in the frequency range 1 427 - 1 517 MHz. For Band 76, this requirement applies in the frequency range 1 432 - 1 517 MHz even though part of the range falls in the spurious domain.

Table 4.3.13.2.1.4-2: Unwanted emission limits within 1 427 MHz - 1 517 MHz

Frequency offset of measurement filter centre frequency, f_{offset}	EIRP limit [dBm]	Measurement bandwidth
2,5 MHz	16,3	5 MHz
7,5 MHz	11	5 MHz
$12,5 \text{ MHz} \leq f_{\text{offset}} \leq f_{\text{offset}_{\text{max}}}$	9	5 MHz

NOTE: For Band 32, when non-MFCN services are deployed in the adjacent bands, $f_{\text{offset}_{\text{max}}}$ denotes the frequency difference between the lower *Base Station RF Bandwidth edge* and 1 454,5 MHz, and the frequency difference between the upper *Base Station RF Bandwidth edge* and 1 489,5 MHz for the set channel position. For Band 32, when MFCN services are deployed in the adjacent frequencies, Band 75 and Band 76, $f_{\text{offset}_{\text{max}}}$ denotes the frequency difference between the lower *Base Station RF Bandwidth edge* and 1 429,5 MHz, and the frequency difference between the upper *Base Station RF Bandwidth edge* and 1 514,5 MHz for the set channel position.

For BS operating in Band 32 within 1 452 MHz - 1 492 MHz the maximum level of emissions, measured as EIRP, on centre frequencies f_{filter} and with filter bandwidth according to table 4.3.13.2.1.4-3, shall not exceed the EIRP limits indicated in the table. This requirement applies in the frequency range 1 429 MHz - 1 518 MHz even though part of the range falls in the spurious domain.

Table 4.3.13.2.1.4-3: Unwanted emission emission limits outside 1 452 MHz - 1 492 MHz

Filter centre frequency, F_{filter}	EIRP limit [dBm]	Measurement bandwidth
$1\,429,5\text{ MHz} \leq F_{\text{filter}} \leq 1\,448,5\text{ MHz}$	-20	1 MHz
$F_{\text{filter}} = 1\,450,5\text{ MHz}$	14	3 MHz
$F_{\text{filter}} = 1\,493,5\text{ MHz}$	14	3 MHz
$1\,495,5\text{ MHz} \leq F_{\text{filter}} \leq 1\,517,5\text{ MHz}$	-20	1 MHz

For protection of systems above 2 400 MHz, the total radiated power of unwanted emissions for BS operating in band 40 shall not exceed the limits specified in table 4.3.13.2.1.4-3.

Table 4.3.13.2.1.4-3: Additional operating band unwanted emission limits for BS operating in band 40

Frequency range	Rated transmitter TRP $P_{\text{rated,t,TRP}}$	Limit	Measurement bandwidth
Above 2 403 MHz	$P_{\text{rated,t,TRP}} > 47\text{ dBm}$	-13 dBm	5 MHz
	$33\text{ dBm} < P_{\text{rated,t,TRP}} \leq 47\text{ dBm}$	$P_{\text{rated,t,TRP}} - 60\text{ dBm}$	5 MHz
	$P_{\text{rated,t,TRP}} \leq 33\text{ dBm}$	-27 dBm	5 MHz

NOTE: For a BS operating in band 20, additional limits for protection of DTT are described in clause 6.7.5.5.4.3 of ETSI TS 137 145-2 [3]. This statement is provided for information and does not have any impact on the conformance requirements or essential radio test suites in the present document.

4.3.13.2.2 Limits for *single RAT E-UTRA operation*

4.3.13.2.2.1 General

This requirement applies for RIBs supporting only *single RAT E-UTRA operation*.

The emissions shall not exceed the limits specified in the tables below, where:

- Δf is the separation between the *channel edge* frequency and the nominal -3 dB point of the measuring filter closest to the carrier frequency.
- f_{offset} is the separation between the *channel edge* frequency and the centre of the measuring filter.
- $f_{\text{offset}_{\text{max}}}$ is the offset to the frequency Δf_{OBUE} MHz outside the downlink *operating band*.
- Δf_{max} is equal to $f_{\text{offset}_{\text{max}}}$ minus half of the bandwidth of the measuring filter.

For a *multi-band RIB*, inside any *Inter RF Bandwidth gaps* with $W_{\text{gap}} < 2 \times \Delta f_{\text{OBUE}}$ MHz, emissions shall not exceed the cumulative sum of the limits specified at the *Base Station RF Bandwidth edges* on each side of the *Inter RF Bandwidth gap*. The limit for *Base Station RF Bandwidth edge* is specified in tables below, where in this case:

- Δf is the separation between the *Base Station RF Bandwidth edge* frequency and the nominal -3 dB point of the measuring filter closest to the *Base Station RF Bandwidth edge*.
- f_{offset} is the separation between the *Base Station RF Bandwidth edge* frequency and the centre of the measuring filter.
- $f_{\text{offset}_{\text{max}}}$ is equal to the *Inter RF Bandwidth gap* minus half of the bandwidth of the measuring filter.
- Δf_{max} is equal to $f_{\text{offset}_{\text{max}}}$ minus half of the bandwidth of the measuring filter.

For *multi-band RIB*, the *operating band unwanted emission* limits apply also in a supported *operating band* without any carrier transmitted, in the case where there are carrier(s) transmitted in another supported *operating band*. In this case, no cumulative limit is applied in the *inter-band gap* between a supported downlink *operating band* with carrier(s) transmitted and a supported downlink *operating band* without any carrier transmitted; and:

- In case the *inter-band gap* between a supported downlink *operating band* with carrier(s) transmitted and a supported downlink *operating band* without any carrier transmitted is less than $2 \times \Delta f_{\text{OBUE}}$ MHz, $f_{\text{offset}_{\text{max}}}$ shall be the offset to the frequency Δf_{OBUE} MHz outside the outermost edges of the two supported downlink *operating bands* and the *operating band unwanted emission* limit of the band where there are carriers transmitted, as defined in the tables of the present clause, shall apply across both downlink bands.
- In other cases, the *operating band unwanted emission* limit of the band where there are carriers transmitted, as defined in the tables of the present clause for the largest frequency offset (Δf_{max}), shall apply from Δf_{OBUE} MHz below the lowest frequency, up to Δf_{OBUE} MHz above the highest frequency of the supported downlink *operating band* without any carrier transmitted.

For a multicarrier E-UTRA *TAB connector* or a RIB configured for intra-band contiguous or non-contiguous *carrier aggregation* the definitions above apply to the lower edge of the carrier transmitted at the *lowest carrier* frequency and the upper edge of the carrier transmitted at the *highest carrier* frequency within a specified frequency band.

Inside any *sub-block gap* for a RIB operating in *non-contiguous spectrum*, emissions shall not exceed the cumulative sum of the limits specified for the adjacent sub-blocks on each side of the *sub-block gap*. The limit for each sub-block is specified in tables below, where in this case:

- Δf is the separation between the sub-block edge frequency and the nominal -3 dB point of the measuring filter closest to the sub-block edge.
- f_{offset} is the separation between the sub-block edge frequency and the centre of the measuring filter.
- $f_{\text{offset}_{\text{max}}}$ is equal to the *sub-block gap* bandwidth minus half of the bandwidth of the measuring filter.
- Δf_{max} is equal to $f_{\text{offset}_{\text{max}}}$ minus half of the bandwidth of the measuring filter.

4.3.13.2.2.2 Wide Area BS (bands 1, 3, 8, 32, 33 or 65)

For a RIB operating in band 1, 3, 8, 32, 33 or 65, emissions shall not exceed the limits specified in tables below:

Table 4.3.13.2.2-1: Wide Area BS operating band unwanted emissions limits for 1,4 MHz channel bandwidth (E UTRA bands 3, 8, 65)

Frequency offset of measurement filter -3 dB point, Δf	Frequency offset of measurement filter centre frequency, f_{offset}	Limit (notes 1 and 2)	Measurement bandwidth
$0 \text{ MHz} \leq \Delta f < 0,05 \text{ MHz}$	$0,015 \text{ MHz} \leq f_{\text{offset}} < 0,065 \text{ MHz}$	$15,8 \text{ dBm} - 60(f_{\text{offset}}/\text{MHz} - 0,015) \text{ dB}$	30 kHz
$0,05 \text{ MHz} \leq \Delta f < 0,15 \text{ MHz}$	$0,065 \text{ MHz} \leq f_{\text{offset}} < 0,165 \text{ MHz}$	$12,8 \text{ dBm} - 160(f_{\text{offset}}/\text{MHz} - 0,065) \text{ dB}$	30 kHz
$0,15 \text{ MHz} \leq \Delta f < 0,2 \text{ MHz}$	$0,165 \text{ MHz} \leq f_{\text{offset}} < 0,215 \text{ MHz}$	-3,2 dBm	30 kHz
$0,2 \text{ MHz} \leq \Delta f < 1 \text{ MHz}$	$0,215 \text{ MHz} \leq f_{\text{offset}} < 1,015 \text{ MHz}$	$-3,2 \text{ dBm} - 15(f_{\text{offset}}/\text{MHz} - 0,215) \text{ dB}$	30 kHz
(note 3)	$1,015 \text{ MHz} \leq f_{\text{offset}} < 1,5 \text{ MHz}$	-15,2 dBm	30 kHz
$1 \text{ MHz} \leq \Delta f \leq 2,8 \text{ MHz}$	$1,5 \text{ MHz} \leq f_{\text{offset}} < 3,3 \text{ MHz}$	-2,2 dBm	1 MHz
$2,8 \text{ MHz} \leq \Delta f < \min(10 \text{ MHz}, \Delta f_{\text{max}})$	$3,3 \text{ MHz} \leq f_{\text{offset}} < \min(10,5 \text{ MHz}, f_{\text{offset}_{\text{max}}})$	-4,2 dBm (note 4)	1 MHz
$10 \text{ MHz} \leq \Delta f \leq \Delta f_{\text{max}}$	$10,5 \text{ MHz} \leq f_{\text{offset}} < f_{\text{offset}_{\text{max}}}$	-6 dBm (note 4)	1 MHz

NOTE 1: For a RIB supporting *non-contiguous spectrum* operation within any *operating band* the limit within *sub-block gaps* is calculated as a cumulative sum of contributions from adjacent sub-blocks on each side of the *sub-block gap*, where the contribution from the far-end *sub-block* shall be scaled according to the *measurement bandwidth* of the near-end *sub-block*. Exception is $\Delta f \geq 10 \text{ MHz}$ from both adjacent sub-blocks on each side of the *sub-block gap*, where the limit within *sub-block gaps* shall be -6 dBm/MHz.

NOTE 2: For a *multi-band RIB* with *Inter RF Bandwidth gap* $< 2 \times \Delta f_{\text{OBUE}}$ MHz the limit within the *Inter RF Bandwidth gaps* is calculated as a cumulative sum of contributions from adjacent *sub-blocks* or *Base Station RF Bandwidth* on each side of the *Inter RF Bandwidth gap*, where the contribution from the far-end *sub-block* or *Base Station RF Bandwidth* shall be scaled according to the *measurement bandwidth* of the near-end *sub-block* or *Base Station RF Bandwidth*.

NOTE 3: This frequency range ensures that the range of values of f_{offset} is continuous.

NOTE 4: The requirement is not applicable when $\Delta f_{\text{max}} < 10 \text{ MHz}$.

Table 4.3.13.2.2-2: Wide Area BS operating band unwanted emissions limits for 3 MHz channel bandwidth (E UTRA bands 3, 8, 65)

Frequency offset of measurement filter -3 dB point, Δf	Frequency offset of measurement filter centre frequency, f_{offset}	Limit (notes 1 and 2)	Measurement bandwidth
$0 \text{ MHz} \leq \Delta f < 0,05 \text{ MHz}$	$0,015 \text{ MHz} \leq f_{\text{offset}} < 0,065 \text{ MHz}$	$15,8 \text{ dBm} - 60(f_{\text{offset_MHz}} - 0,015) \text{ dB}$	30 kHz
$0,05 \text{ MHz} \leq \Delta f < 0,15 \text{ MHz}$	$0,065 \text{ MHz} \leq f_{\text{offset}} < 0,165 \text{ MHz}$	$12,8 \text{ dBm} - 160(f_{\text{offset}}/\text{MHz} - 0,065) \text{ dB}$	30 kHz
$0,15 \text{ MHz} \leq \Delta f < 0,2 \text{ MHz}$	$0,165 \text{ MHz} \leq f_{\text{offset}} < 0,215 \text{ MHz}$	-3,2 dBm	30 kHz
$0,2 \text{ MHz} \leq \Delta f < 1 \text{ MHz}$	$0,215 \text{ MHz} \leq f_{\text{offset}} < 1,015 \text{ MHz}$	$-3,2 \text{ dBm} - 15(f_{\text{offset}}/\text{MHz} - 0,215) \text{ dB}$	30 kHz
(note 3)	$1,015 \text{ MHz} \leq f_{\text{offset}} < 1,5 \text{ MHz}$	-15,2 dBm	30 kHz
$1 \text{ MHz} \leq \Delta f \leq 6 \text{ MHz}$	$1,5 \text{ MHz} \leq f_{\text{offset}} < 6,5 \text{ MHz}$	-2,2 dBm	1 MHz
$6 \text{ MHz} \leq \Delta f < \min(10 \text{ MHz}, \Delta f_{\text{max}})$	$6,5 \text{ MHz} \leq f_{\text{offset}} < \min(10,5 \text{ MHz}, f_{\text{offset}_{\text{max}}})$	-4,2 dBm	1 MHz
$10 \text{ MHz} \leq \Delta f \leq \Delta f_{\text{max}}$	$10,5 \text{ MHz} \leq f_{\text{offset}} < f_{\text{offset}_{\text{max}}}$	-6 dBm (note 4)	

NOTE 1: For a RIB supporting *non-contiguous spectrum* operation within any *operating band* the limit within *sub-block gaps* is calculated as a cumulative sum of contributions from adjacent sub-blocks on each side of the *sub-block gap*, where the contribution from the far-end *sub-block* shall be scaled according to the *measurement bandwidth* of the near-end *sub-block*. Exception is $\Delta f \geq 10 \text{ MHz}$ from both adjacent sub-blocks on each side of the *sub-block gap*, where the limit within *sub-block gaps* shall be -6 dBm/MHz.

NOTE 2: For a *multi-band RIB* with *Inter RF Bandwidth gap* $< 2 \times \Delta f_{\text{OBUE}}$ MHz the limit within the *Inter RF Bandwidth gaps* is calculated as a cumulative sum of contributions from adjacent *sub-blocks* or *Base Station RF Bandwidth* on each side of the *Inter RF Bandwidth gap*, where the contribution from the far-end *sub-block* or *Base Station RF Bandwidth* shall be scaled according to the *measurement bandwidth* of the near-end *sub-block* or *Base Station RF Bandwidth*.

NOTE 3: This frequency range ensures that the range of values of f_{offset} is continuous.

NOTE 4: The requirement is not applicable when $\Delta f_{\text{max}} < 10 \text{ MHz}$.

Table 4.3.13.2.2-3: Wide Area BS operating band unwanted emissions limits for 5 MHz, 10 MHz, 15 MHz and 20 MHz channel bandwidth (E-UTRA bands 1, 3, 7, 8, 32, 33, 38, 65, 69)

Frequency offset of measurement filter -3 dB point, Δf	Frequency offset of measurement filter centre frequency, f_{offset}	Limit (notes 1 and 2)	Measurement bandwidth
$0 \text{ MHz} \leq \Delta f < 0,2 \text{ MHz}$	$0,015 \text{ MHz} \leq f_{\text{offset}} < 0,215 \text{ MHz}$	-3,2 dBm	30 kHz
$0,2 \text{ MHz} \leq \Delta f < 1 \text{ MHz}$	$0,215 \text{ MHz} \leq f_{\text{offset}} < 1,015 \text{ MHz}$	$-3,2 \text{ dBm} - 15(f_{\text{offset}}/\text{MHz} - 0,215) \text{ dB}$	30 kHz
(note 3)	$1,015 \text{ MHz} \leq f_{\text{offset}} < 1,5 \text{ MHz}$	-15,2 dBm	30 kHz
$1 \text{ MHz} \leq \Delta f \leq \min(10 \text{ MHz}, \Delta f_{\text{max}})$	$1,5 \text{ MHz} \leq f_{\text{offset}} < \min(10,5 \text{ MHz}, f_{\text{offset}_{\text{max}}})$	-2,2 dBm	1 MHz
$10 \text{ MHz} \leq \Delta f \leq \Delta f_{\text{max}}$	$10,5 \text{ MHz} \leq f_{\text{offset}} < f_{\text{offset}_{\text{max}}}$	-6 dBm (note 4)	1 MHz
NOTE 1: For a RIB supporting <i>non-contiguous spectrum</i> operation within any <i>operating band</i> the limit within <i>sub-block gaps</i> is calculated as a cumulative sum of contributions from adjacent sub-blocks on each side of the <i>sub-block gap</i> , where the contribution from the far-end <i>sub-block</i> shall be scaled according to the <i>measurement bandwidth</i> of the near-end <i>sub-block</i> . Exception is $\Delta f \geq 10 \text{ MHz}$ from both adjacent sub-blocks on each side of the <i>sub-block gap</i> , where the limit within <i>sub-block gaps</i> shall be -6 dBm/MHz.			
NOTE 2: For a <i>multi-band RIB</i> with <i>Inter RF Bandwidth gap</i> $< 2 \times \Delta f_{\text{OBUE}}$ MHz the limit within the <i>Inter RF Bandwidth gaps</i> is calculated as a cumulative sum of contributions from adjacent <i>sub-blocks</i> or <i>Base Station RF Bandwidth</i> on each side of the <i>Inter RF Bandwidth gap</i> , where the contribution from the far-end <i>sub-block</i> or <i>Base Station RF Bandwidth</i> shall be scaled according to the <i>measurement bandwidth</i> of the near-end <i>sub-block</i> or <i>Base Station RF Bandwidth</i> .			
NOTE 3: This frequency range ensures that the range of values of f_{offset} is continuous.			
NOTE 4: The requirement is not applicable when $\Delta f_{\text{max}} < 10 \text{ MHz}$.			

4.3.13.2.2.3 Wide Area BS (bands 7, 22, 38, 40, 41, 42, 43, 50, 69 and 75)

For E-UTRA Wide Area BS operating in bands 7, 38, 40 and 69 the emissions shall not exceed the limits specified in tables 4.3.13.2.2.3-1, 4.3.13.2.2.3-2 and 4.3.13.2.2.3-3.

For E-UTRA Wide Area BS operating in bands 22, 42 and 43, the emissions shall not exceed the limits specified in tables 4.3.13.2.2.3-1a, 4.3.13.2.2.3-2a and 4.3.13.2.2.3-3a.

Table 4.3.13.2.2.3-1: Wide Area BS operating band unwanted emissions limits for 1,4 MHz channel bandwidth (E UTRA bands 7, 38, 40, 41, 50, 69, 75)

Frequency offset of measurement filter -3 dB point, Δf	Frequency offset of measurement filter centre frequency, f_{offset}	Limit (notes 1 and 2)	Measurement bandwidth
$0 \text{ MHz} \leq \Delta f < 1,4 \text{ MHz}$	$0,05 \text{ MHz} \leq f_{\text{offset}} < 1,45 \text{ MHz}$	$9,8 \text{ dBm} - 10/1,4(f_{\text{offset}}/\text{MHz} - 0,05) \text{ dB}$	100 kHz
$1,4 \text{ MHz} \leq \Delta f < 2,8 \text{ MHz}$	$1,45 \text{ MHz} \leq f_{\text{offset}} < 2,85 \text{ MHz}$	-0,2 dBm	100 kHz
$2,8 \text{ MHz} \leq \Delta f < \min(10 \text{ MHz}, \Delta f_{\text{max}})$	$3,3 \text{ MHz} \leq f_{\text{offset}} < \min(10,5 \text{ MHz}, f_{\text{offset}_{\text{max}}})$	-4,2 dBm (note 3)	1 MHz
$10 \text{ MHz} \leq \Delta f \leq \Delta f_{\text{max}}$	$10,5 \text{ MHz} \leq f_{\text{offset}} < f_{\text{offset}_{\text{max}}}$	-6 dBm (note 3)	1 MHz
NOTE 1: For a RIB supporting <i>non-contiguous spectrum</i> operation within any <i>operating band</i> the limit within <i>sub-block gaps</i> is calculated as a cumulative sum of contributions from adjacent sub-blocks on each side of the <i>sub-block gap</i> , where the contribution from the far-end <i>sub-block</i> shall be scaled according to the <i>measurement bandwidth</i> of the near-end <i>sub-block</i> . Exception is $\Delta f \geq 10 \text{ MHz}$ from both adjacent sub-blocks on each side of the <i>sub-block gap</i> , where the limit within <i>sub-block gaps</i> shall be -6 dBm/MHz.			
NOTE 2: For a <i>multi-band RIB</i> with <i>Inter RF Bandwidth gap</i> $< 2 \times \Delta f_{\text{OBUE}}$ MHz the limit within the <i>Inter RF Bandwidth gaps</i> is calculated as a cumulative sum of contributions from adjacent <i>sub-blocks</i> or <i>Base Station RF Bandwidth</i> on each side of the <i>Inter RF Bandwidth gap</i> , where the contribution from the far-end <i>sub-block</i> or <i>Base Station RF Bandwidth</i> shall be scaled according to the <i>measurement bandwidth</i> of the near-end <i>sub-block</i> or <i>Base Station RF Bandwidth</i> .			
NOTE 3: The requirement is not applicable when $\Delta f_{\text{max}} < 10 \text{ MHz}$.			

Table 4.3.13.2.2.3-1a: Wide Area BS operating band unwanted emissions limits for 1,4 MHz channel bandwidth (E UTRA bands 22, 42 and 43)

Frequency offset of measurement filter -3 dB point, Δf	Frequency offset of measurement filter centre frequency, f_{offset}	Limit (notes 1 and 2)	Measurement bandwidth
$0 \text{ MHz} \leq \Delta f < 1,4 \text{ MHz}$	$0,05 \text{ MHz} \leq f_{\text{offset}} < 1,45 \text{ MHz}$	$10 \text{ dBm} - 10/1,4(f_{\text{offset}}/\text{MHz}-0,05) \text{ dB}$	100 kHz
$1,4 \text{ MHz} \leq \Delta f < 2,8 \text{ MHz}$	$1,45 \text{ MHz} \leq f_{\text{offset}} < 2,85 \text{ MHz}$	0 dBm	100 kHz
$2,8 \text{ MHz} \leq \Delta f < \min(10 \text{ MHz}, \Delta f_{\text{max}})$	$3,3 \text{ MHz} \leq f_{\text{offset}} < \min(10,5 \text{ MHz}, f_{\text{offset}_{\text{max}}})$	-4 dBm (note 3)	1 MHz
$10 \text{ MHz} \leq \Delta f \leq \Delta f_{\text{max}}$	$10,5 \text{ MHz} \leq f_{\text{offset}} < f_{\text{offset}_{\text{max}}}$	-6 dBm (note 3)	1 MHz
NOTE 1: For a RIB supporting <i>non-contiguous spectrum</i> operation within any <i>operating band</i> the limit within <i>sub-block gaps</i> is calculated as a cumulative sum of contributions from adjacent sub-blocks on each side of the <i>sub-block gap</i> , where the contribution from the far-end <i>sub-block</i> shall be scaled according to the <i>measurement bandwidth</i> of the near-end <i>sub-block</i> . Exception is $\Delta f \geq 10 \text{ MHz}$ from both adjacent sub-blocks on each side of the <i>sub-block gap</i> , where the limit within <i>sub-block gaps</i> shall be -6 dBm/MHz.			
NOTE 2: For a <i>multi-band RIB</i> with <i>Inter RF Bandwidth gap</i> $< 2 \times \Delta f_{\text{OBUE}}$ MHz the limit within the <i>Inter RF Bandwidth gaps</i> is calculated as a cumulative sum of contributions from adjacent <i>sub-blocks</i> or <i>Base Station RF Bandwidth</i> on each side of the <i>Inter RF Bandwidth gap</i> , where the contribution from the far-end <i>sub-block</i> or <i>Base Station RF Bandwidth</i> shall be scaled according to the <i>measurement bandwidth</i> of the near-end <i>sub-block</i> or <i>Base Station RF Bandwidth</i> .			
NOTE 3: The requirement is not applicable when $\Delta f_{\text{max}} < 10 \text{ MHz}$.			

Table 4.3.13.2.2.3-2: Wide Area AAS BS operating band unwanted emissions limits for 3 MHz channel bandwidth (E UTRA bands 7, 38, 40, 41, 50, 69, 75)

Frequency offset of measurement filter -3 dB point, Δf	Frequency offset of measurement filter centre frequency, f_{offset}	Limit (notes 1 and 2)	Measurement bandwidth
$0 \text{ MHz} \leq \Delta f < 3 \text{ MHz}$	$0,05 \text{ MHz} \leq f_{\text{offset}} < 3,05 \text{ MHz}$	$5,8 \text{ dBm} - 10/3(f_{\text{offset}}/\text{MHz} - 0,05) \text{ dB}$	100 kHz
$3 \text{ MHz} \leq \Delta f < 6 \text{ MHz}$	$3,05 \text{ MHz} \leq f_{\text{offset}} < 6,05 \text{ MHz}$	-4,2 dBm	100 kHz
$6 \text{ MHz} \leq \Delta f < \min(10 \text{ MHz}, \Delta f_{\text{max}})$	$6,5 \text{ MHz} \leq f_{\text{offset}} < \min(10,5 \text{ MHz}, f_{\text{offset}_{\text{max}}})$	-4,2 dBm (note 3)	1 MHz
$10 \text{ MHz} \leq \Delta f \leq \Delta f_{\text{max}}$	$10,5 \text{ MHz} \leq f_{\text{offset}} < f_{\text{offset}_{\text{max}}}$	-6 dBm (note 3)	1 MHz
NOTE 1: For a RIB supporting <i>non-contiguous spectrum</i> operation within any <i>operating band</i> the limit within <i>sub-block gaps</i> is calculated as a cumulative sum of contributions from adjacent sub-blocks on each side of the <i>sub-block gap</i> , where the contribution from the far-end <i>sub-block</i> shall be scaled according to the <i>measurement bandwidth</i> of the near-end <i>sub-block</i> . Exception is $\Delta f \geq 10 \text{ MHz}$ from both adjacent sub-blocks on each side of the <i>sub-block gap</i> , where the limit within <i>sub-block gaps</i> shall be -6 dBm/MHz.			
NOTE 2: For a <i>multi-band RIB</i> with <i>Inter RF Bandwidth gap</i> $< 2 \times \Delta f_{\text{OBUE}}$ MHz the limit within the <i>Inter RF Bandwidth gaps</i> is calculated as a cumulative sum of contributions from adjacent <i>sub-blocks</i> or <i>Base Station RF Bandwidth</i> on each side of the <i>Inter RF Bandwidth gap</i> , where the contribution from the far-end <i>sub-block</i> or <i>Base Station RF Bandwidth</i> shall be scaled according to the <i>measurement bandwidth</i> of the near-end <i>sub-block</i> or <i>Base Station RF Bandwidth</i> .			
NOTE 3: The requirement is not applicable when $\Delta f_{\text{max}} < 10 \text{ MHz}$.			

Table 4.3.13.2.2.3-2a: Wide Area BS operating band unwanted emissions limits for 3 MHz channel bandwidth (E UTRA bands 22, 42 and 43)

Frequency offset of measurement filter -3 dB point, Δf	Frequency offset of measurement filter centre frequency, f_{offset}	Limit (notes 1 and 2)	Measurement bandwidth
$0 \text{ MHz} \leq \Delta f < 3 \text{ MHz}$	$0,05 \text{ MHz} \leq f_{\text{offset}} < 3,05 \text{ MHz}$	$6 \text{ dBm} - 10/3(f_{\text{offset}}/\text{MHz}-0,05) \text{ dB}$	100 kHz
$3 \text{ MHz} \leq \Delta f < 6 \text{ MHz}$	$3,05 \text{ MHz} \leq f_{\text{offset}} < 6,05 \text{ MHz}$	-4 dBm	100 kHz
$6 \text{ MHz} \leq \Delta f < \min(10 \text{ MHz}, \Delta f_{\text{max}})$	$6,5 \text{ MHz} \leq f_{\text{offset}} < \min(10,5 \text{ MHz}, f_{\text{offset}_{\text{max}}})$	-4 dBm (note 3)	1 MHz
$10 \text{ MHz} \leq \Delta f \leq \Delta f_{\text{max}}$	$10,5 \text{ MHz} \leq f_{\text{offset}} < f_{\text{offset}_{\text{max}}}$	-6 dBm (note 3)	1 MHz
NOTE 1: For a RIB supporting <i>non-contiguous spectrum</i> operation within any <i>operating band</i> the limit within <i>sub-block gaps</i> is calculated as a cumulative sum of contributions from adjacent sub-blocks on each side of the <i>sub-block gap</i> , where the contribution from the far-end <i>sub-block</i> shall be scaled according to the <i>measurement bandwidth</i> of the near-end <i>sub-block</i> . Exception is $\Delta f \geq 10 \text{ MHz}$ from both adjacent sub-blocks on each side of the <i>sub-block gap</i> , where the limit within <i>sub-block gaps</i> shall be -6 dBm/MHz.			
NOTE 2: For a <i>multi-band RIB</i> with <i>Inter RF Bandwidth gap</i> $< 2 \times \Delta f_{\text{OBUE}}$ MHz the limit within the <i>Inter RF Bandwidth gaps</i> is calculated as a cumulative sum of contributions from adjacent <i>sub-blocks</i> or <i>Base Station RF Bandwidth</i> on each side of the <i>Inter RF Bandwidth gap</i> , where the contribution from the far-end <i>sub-block</i> or <i>Base Station RF Bandwidth</i> shall be scaled according to the <i>measurement bandwidth</i> of the near-end <i>sub-block</i> or <i>Base Station RF Bandwidth</i> .			
NOTE 3: The requirement is not applicable when $\Delta f_{\text{max}} < 10 \text{ MHz}$.			

Table 4.3.13.2.2.3-3: Wide Area BS operating band unwanted emissions limits for 5 MHz, 10 MHz, 15 MHz and 20 MHz channel bandwidth (E-UTRA bands 7, 38, 40, 41, 50, 69, 75)

Frequency offset of measurement filter -3 dB point, Δf	Frequency offset of measurement filter centre frequency, f_{offset}	Limit (notes 1 and 2)	Measurement bandwidth
$0 \text{ MHz} \leq \Delta f < 5 \text{ MHz}$	$0,05 \text{ MHz} \leq f_{\text{offset}} < 5,05 \text{ MHz}$	$3,8 \text{ dBm} - 7/5(f_{\text{offset}}/\text{MHz}-0,05) \text{ dB}$	100 kHz
$5 \text{ MHz} \leq \Delta f < \min(10 \text{ MHz}, \Delta f_{\text{max}})$	$5,05 \text{ MHz} \leq f_{\text{offset}} < \min(10,05 \text{ MHz}, f_{\text{offset}_{\text{max}}})$	-3,2 dBm	100 kHz
$10 \text{ MHz} \leq \Delta f \leq \Delta f_{\text{max}}$	$10,5 \text{ MHz} \leq f_{\text{offset}} < f_{\text{offset}_{\text{max}}}$	-6 dBm (note 3)	1 MHz
NOTE 1: For a RIB supporting <i>non-contiguous spectrum</i> operation within any <i>operating band</i> the limit within <i>sub-block gaps</i> is calculated as a cumulative sum of contributions from adjacent sub-blocks on each side of the <i>sub-block gap</i> , where the contribution from the far-end <i>sub-block</i> shall be scaled according to the <i>measurement bandwidth</i> of the near-end <i>sub-block</i> . Exception is $\Delta f \geq 10 \text{ MHz}$ from both adjacent sub-blocks on each side of the <i>sub-block gap</i> , where the limit within <i>sub-block gaps</i> shall be -6 dBm/MHz.			
NOTE 2: For a <i>multi-band RIB</i> with <i>Inter RF Bandwidth gap</i> $< 2 \times \Delta f_{\text{OBUE}}$ MHz the limit within the <i>Inter RF Bandwidth gaps</i> is calculated as a cumulative sum of contributions from adjacent <i>sub-blocks</i> or <i>Base Station RF Bandwidth</i> on each side of the <i>Inter RF Bandwidth gap</i> , where the contribution from the far-end <i>sub-block</i> or <i>Base Station RF Bandwidth</i> shall be scaled according to the <i>measurement bandwidth</i> of the near-end <i>sub-block</i> or <i>Base Station RF Bandwidth</i> .			
NOTE 3: The requirement is not applicable when $\Delta f_{\text{max}} < 10 \text{ MHz}$.			

Table 4.3.13.2.2.3-3a: Wide Area BS operating band unwanted emissions limits for 5 MHz, 10 MHz, 15 MHz and 20 MHz *channel bandwidth* (E-UTRA bands 22, 42 and 43)

Frequency offset of measurement filter -3 dB point, Δf	Frequency offset of measurement filter centre frequency, f_{offset}	Limit (notes 1 and 2)	Measurement bandwidth
$0 \text{ MHz} \leq \Delta f < 5 \text{ MHz}$	$0,05 \text{ MHz} \leq f_{\text{offset}} < 5,05 \text{ MHz}$	$4 \text{ dBm} - 7/5(f_{\text{offset}}/\text{MHz} - 0,05) \text{ dB}$	100 kHz
$5 \text{ MHz} \leq \Delta f < \min(10 \text{ MHz}, \Delta f_{\text{max}})$	$5,05 \text{ MHz} \leq f_{\text{offset}} < \min(10,05 \text{ MHz}, f_{\text{offsetmax}})$	-3 dBm	100 kHz
$10 \text{ MHz} \leq \Delta f \leq \Delta f_{\text{max}}$	$10,5 \text{ MHz} \leq f_{\text{offset}} < f_{\text{offsetmax}}$	-6 dBm (note 3)	1 MHz
NOTE 1: For a RIB supporting <i>non-contiguous spectrum</i> operation within any <i>operating band</i> the limit within <i>sub-block gaps</i> is calculated as a cumulative sum of contributions from adjacent sub-blocks on each side of the <i>sub-block gap</i> , where the contribution from the far-end <i>sub-block</i> shall be scaled according to the <i>measurement bandwidth</i> of the near-end <i>sub-block</i> . Exception is $\Delta f \geq 10 \text{ MHz}$ from both adjacent sub-blocks on each side of the <i>sub-block gap</i> , where the limit within <i>sub-block gaps</i> shall be -6 dBm/MHz.			
NOTE 2: For a <i>multi-band RIB</i> with <i>Inter RF Bandwidth gap</i> $< 2 \times \Delta f_{\text{OBUE}}$ MHz the limit within the <i>Inter RF Bandwidth gaps</i> is calculated as a cumulative sum of contributions from adjacent <i>sub-blocks</i> or <i>Base Station RF Bandwidth</i> on each side of the <i>Inter RF Bandwidth gap</i> , where the contribution from the far-end <i>sub-block</i> or <i>Base Station RF Bandwidth</i> shall be scaled according to the <i>measurement bandwidth</i> of the near-end <i>sub-block</i> or <i>Base Station RF Bandwidth</i> .			
NOTE 3: The requirement is not applicable when $\Delta f_{\text{max}} < 10 \text{ MHz}$.			

4.3.13.2.2.4 Wide Area AAS BS (bands 20, 28, 31, 67 and 68)

For E-UTRA Wide Area AAS BS operating in band 20, 28, 31, 67 and 68 the emissions shall not exceed the limits specified in tables 4.3.13.2.2.4-1 to 4.3.13.2.2.4-3.

Table 4.3.13.2.2.4-1: Wide Area BS operating band unwanted emissions limits for 1,4 MHz *channel bandwidth* (E UTRA bands 20, 28, 31, 67, 68, 72, 87, 88)

Frequency offset of measurement filter -3 dB point, Δf	Frequency offset of measurement filter centre frequency, f_{offset}	Limit (notes 1 and 2)	Measurement bandwidth
$0 \text{ MHz} \leq \Delta f < 1,4 \text{ MHz}$	$0,05 \text{ MHz} \leq f_{\text{offset}} < 1,45 \text{ MHz}$	$9,8 \text{ dBm} - 10/1,4(f_{\text{offset}}/\text{MHz} - 0,05) \text{ dB}$	100 kHz
$1,4 \text{ MHz} \leq \Delta f < 2,8 \text{ MHz}$	$1,45 \text{ MHz} \leq f_{\text{offset}} < 2,85 \text{ MHz}$	-0,2 dBm	100 kHz
$2,8 \text{ MHz} \leq \Delta f \leq \min(10 \text{ MHz}, \Delta f_{\text{max}})$	$2,85 \text{ MHz} \leq f_{\text{offset}} < \min(10,05 \text{ MHz}, f_{\text{offsetmax}})$	-2,2 dBm	100 kHz
$10 \text{ MHz} \leq \Delta f \leq \Delta f_{\text{max}}$	$10,05 \text{ MHz} \leq f_{\text{offset}} < f_{\text{offsetmax}}$	-4 dBm (note 3)	100 kHz
NOTE 1: For a RIB supporting <i>non-contiguous spectrum</i> operation within any <i>operating band</i> the limit within <i>sub-block gaps</i> is calculated as a cumulative sum of contributions from adjacent sub-blocks on each side of the <i>sub-block gap</i> . Exception is $\Delta f \geq 10 \text{ MHz}$ from both adjacent sub-blocks on each side of the <i>sub-block gap</i> , where the limit within <i>sub-block gaps</i> shall be -4 dBm/100 kHz.			
NOTE 2: For a <i>multi-band RIB</i> with <i>Inter RF Bandwidth gap</i> $< 2 \times \Delta f_{\text{OBUE}}$ MHz the limit within the <i>Inter RF Bandwidth gaps</i> is calculated as a cumulative sum of contributions from adjacent <i>sub-blocks</i> or <i>Base Station RF Bandwidth</i> on each side of the <i>Inter RF Bandwidth gap</i> .			
NOTE 3: The requirement is not applicable when $\Delta f_{\text{max}} < 10 \text{ MHz}$.			

Table 4.3.13.2.2.4-2: Wide Area BS operating band unwanted emissions limits for 3 MHz channel bandwidth (E UTRA bands 20, 28, 31, 67, 68, 72, 87, 88)

Frequency offset of measurement filter -3 dB point, Δf	Frequency offset of measurement filter centre frequency, f_{offset}	Limit (notes 1 and 2)	Measurement bandwidth
$0 \text{ MHz} \leq \Delta f < 3 \text{ MHz}$	$0,05 \text{ MHz} \leq f_{\text{offset}} < 3,05 \text{ MHz}$	$5,8 \text{ dBm} - 10/3(f_{\text{offset}}/\text{MHz}-0,05) \text{ dB}$	100 kHz
$3 \text{ MHz} \leq \Delta f < 6 \text{ MHz}$	$3,05 \text{ MHz} \leq f_{\text{offset}} < 6,05 \text{ MHz}$	-4,2 dBm	100 kHz
$6 \text{ MHz} \leq \Delta f \leq \min(10 \text{ MHz}, \Delta f_{\text{max}})$	$6,05 \text{ MHz} \leq f_{\text{offset}} < \min(10,05 \text{ MHz}, f_{\text{offsetmax}})$	-2,2 dBm (note 3)	100 kHz
$10 \text{ MHz} \leq \Delta f \leq \Delta f_{\text{max}}$	$10,05 \text{ MHz} \leq f_{\text{offset}} < f_{\text{offsetmax}}$	-4 dBm (note 3)	100 kHz

NOTE 1: For a RIB supporting *non-contiguous spectrum* operation within any *operating band* the limit within *sub-block gaps* is calculated as a cumulative sum of contributions from adjacent sub-blocks on each side of the *sub-block gap*. Exception is $\Delta f \geq 10 \text{ MHz}$ from both adjacent sub-blocks on each side of the *sub-block gap*, where the limit within *sub-block gaps* shall be -4 dBm/100 kHz.

NOTE 2: For a *multi-band RIB* with *Inter RF Bandwidth gap* $< 2 \times \Delta f_{\text{OBUE}}$ MHz the limit within the *Inter RF Bandwidth gaps* is calculated as a cumulative sum of contributions from adjacent *sub-blocks* or *Base Station RF Bandwidth* on each side of the *Inter RF Bandwidth gap*.

NOTE 3: The requirement is not applicable when $\Delta f_{\text{max}} < 10 \text{ MHz}$.

Table 4.3.13.2.2.4-3: Wide Area BS operating band unwanted emissions limits for 5 MHz, 10 MHz, 15 MHz and 20 MHz channel bandwidth (E-UTRA bands 20, 28, 31, 67, 68, 72, 87, 88)

Frequency offset of measurement filter -3 dB point, Δf	Frequency offset of measurement filter centre frequency, f_{offset}	Limit (notes 1 and 2)	Measurement bandwidth
$0 \text{ MHz} \leq \Delta f < 5 \text{ MHz}$	$0,05 \text{ MHz} \leq f_{\text{offset}} < 5,05 \text{ MHz}$	$3,8 \text{ dBm} - 7/5(f_{\text{offset}}/\text{MHz}-0,05) \text{ dB}$	100 kHz
$5 \text{ MHz} \leq \Delta f < \min(10 \text{ MHz}, \Delta f_{\text{max}})$	$5,05 \text{ MHz} \leq f_{\text{offset}} < \min(10,05 \text{ MHz}, f_{\text{offsetmax}})$	-3,2 dBm	100 kHz
$10 \text{ MHz} \leq \Delta f \leq \Delta f_{\text{max}}$	$10,05 \text{ MHz} \leq f_{\text{offset}} < f_{\text{offsetmax}}$	-4 dBm (note 3)	100 kHz

NOTE 1: For a RIB supporting *non-contiguous spectrum* operation within any *operating band* the limit within *sub-block gaps* is calculated as a cumulative sum of contributions from adjacent sub-blocks on each side of the *sub-block gap*. Exception is $\Delta f \geq 10 \text{ MHz}$ from both adjacent sub-blocks on each side of the *sub-block gap*, where the limit within *sub-block gaps* shall be -4 dBm/100 kHz.

NOTE 2: For a *multi-band RIB* with *Inter RF Bandwidth gap* $< 2 \times \Delta f_{\text{OBUE}}$ MHz the limit within the *Inter RF Bandwidth gaps* is calculated as a cumulative sum of contributions from adjacent *sub-blocks* or *Base Station RF Bandwidth* on each side of the *Inter RF Bandwidth gap*.

NOTE 3: The requirement is not applicable when $\Delta f_{\text{max}} < 10 \text{ MHz}$.

4.3.13.2.2.5 Medium Range BS

For an Medium Range BS in E-UTRA bands $\leq 3 \text{ GHz}$, emissions shall not exceed the limits specified in tables 4.3.13.2.2.5-1, 4.3.13.2.2.5-3, 4.3.13.2.2.5-5, 4.3.13.2.2.5-7, 4.3.13.2.2.5-9 and 4.3.13.2.2.5-11.

For an Medium Range BS in E-UTRA bands $> 3 \text{ GHz}$, emissions shall not exceed the limits specified in tables 4.3.13.2.2.5-2, 4.3.13.2.2.5-4, 4.3.13.2.2.5-6, 4.3.13.2.2.5-8, 4.3.13.2.2.5-10 and 4.3.13.2.2.5-12.

Table 4.3.13.2.2.5-1: Medium Range BS operating band unwanted emissions limits for 1,4 MHz channel bandwidth, 40 dBm < P_{rated,c,TRP} ≤ 47 dBm (E-UTRA bands ≤ 3 GHz)

Frequency offset of measurement filter -3 dB point, Δf	Frequency offset of measurement filter centre frequency, f _{offset}	Limit (notes 1 and 2)	Measurement bandwidth
0 MHz ≤ Δf < 1,4 MHz	0,05 MHz ≤ f _{offset} < 1,45 MHz	P _{rated,c,TRP} - 43,2 dB - (10/1,4)×(f _{offset} -0,05) dB	100 kHz
1,4 MHz ≤ Δf < 2,8 MHz	1,45 MHz ≤ f _{offset} < 2,85 MHz	P _{rated,c,TRP} -53,2 dB	100 kHz
2,8 MHz ≤ Δf < min(10 MHz, Δf _{max})	2,85 MHz ≤ f _{offset} < min(10,05 MHz, f _{offset} _{max})	-14,2 dBm (note 3)	100 kHz
10 MHz ≤ Δf ≤ Δf _{max}	10,05 MHz ≤ f _{offset} < f _{offset} _{max}	-16 dBm (note 3)	100 kHz

NOTE 1: For a RIB supporting *non-contiguous spectrum* operation within any *operating band* the limit within *sub-block gaps* is calculated as a cumulative sum of contributions from adjacent sub-blocks on each side of the *sub-block gap*. Exception is Δf ≥ 10 MHz from both adjacent sub-blocks on each side of the *sub-block gap*, where the limit within *sub-block gaps* shall be -16 dBm/100 kHz.

NOTE 2: For a *multi-band RIB* with *Inter RF Bandwidth gap* < 2 × Δf_{OBUE} MHz the limit within the *Inter RF Bandwidth gaps* is calculated as a cumulative sum of contributions from adjacent *sub-blocks* or *Base Station RF Bandwidth* on each side of the *Inter RF Bandwidth gap*.

NOTE 3: The requirement is not applicable when Δf_{max} < 10 MHz.

Table 4.3.13.2.2.5-2: Medium Range BS operating band unwanted emissions limits for 1,4 MHz channel bandwidth, 40 dBm < P_{rated,c,TRP} ≤ 47 dBm (E-UTRA bands > 3 GHz)

Frequency offset of measurement filter -3 dB point, Δf	Frequency offset of measurement filter centre frequency, f _{offset}	Limit (notes 1 and 2)	Measurement bandwidth
0 MHz ≤ Δf < 1,4 MHz	0,05 MHz ≤ f _{offset} < 1,45 MHz	P _{rated,c,TRP} - 43 dB - (10/1,4)×(f _{offset} -0,05) dB	100 kHz
1,4 MHz ≤ Δf < 2,8 MHz	1,45 MHz ≤ f _{offset} < 2,85 MHz	P _{rated,c,TRP} -53 dB	100 kHz
2,8 MHz ≤ Δf < min(10 MHz, Δf _{max})	2,85 MHz ≤ f _{offset} < min(10,05 MHz, f _{offset} _{max})	-14 dBm (note 3)	100 kHz
10 MHz ≤ Δf ≤ Δf _{max}	10,05 MHz ≤ f _{offset} < f _{offset} _{max}	-16 dBm (note 3)	100 kHz

NOTE 1: For a RIB supporting *non-contiguous spectrum* operation within any *operating band* the limit within *sub-block gaps* is calculated as a cumulative sum of contributions from adjacent sub-blocks on each side of the *sub-block gap*. Exception is Δf ≥ 10 MHz from both adjacent sub-blocks on each side of the *sub-block gap*, where the limit within *sub-block gaps* shall be -25 dBm/100 kHz.

NOTE 2: For a *multi-band RIB* with *Inter RF Bandwidth gap* < 2 × Δf_{OBUE} MHz the limit within the *Inter RF Bandwidth gaps* is calculated as a cumulative sum of contributions from adjacent *sub-blocks* or *Base Station RF Bandwidth* on each side of the *Inter RF Bandwidth gap*.

NOTE 3: The requirement is not applicable when Δf_{max} < 10 MHz.

Table 4.3.13.2.2.5-3: Medium Range BS operating band unwanted emissions limits for 1,4 MHz channel bandwidth, P_{rated,c,TRP} ≤ 40 dBm (E-UTRA bands ≤ 3 GHz)

Frequency offset of measurement filter -3 dB point, Δf	Frequency offset of measurement filter centre frequency, f _{offset}	Limit (notes 1 and 2)	Measurement bandwidth
0 MHz ≤ Δf < 1,4 MHz	0,05 MHz ≤ f _{offset} < 1,45 MHz	-3,2 dBm - 10/1,4(f _{offset} /MHz-0,05) dB	100 kHz
1,4 MHz ≤ Δf < 2,8 MHz	1,45 MHz ≤ f _{offset} < 2,85 MHz	-13,2 dBm	100 kHz
2,8 MHz ≤ Δf < min(10 MHz, Δf _{max})	2,85 MHz ≤ f _{offset} < min(10,05 MHz, f _{offset} _{max})	-14,2 dBm (note 3)	100 kHz
10 MHz ≤ Δf ≤ Δf _{max}	10,05 MHz ≤ f _{offset} < f _{offset} _{max}	-16 dBm (note 3)	100 kHz

NOTE 1: For a RIB supporting *non-contiguous spectrum* operation within any *operating band* the limit within *sub-block gaps* is calculated as a cumulative sum of contributions from adjacent sub-blocks on each side of the *sub-block gap*. Exception is Δf ≥ 10 MHz from both adjacent sub-blocks on each side of the *sub-block gap*, where the limit within *sub-block gaps* shall be -16 dBm/100 kHz.

NOTE 2: For a *multi-band RIB* with *Inter RF Bandwidth gap* < 2 × Δf_{OBUE} MHz the limit within the *Inter RF Bandwidth gaps* is calculated as a cumulative sum of contributions from adjacent *sub-blocks* or *Base Station RF Bandwidth* on each side of the *Inter RF Bandwidth gap*.

NOTE 3: The requirement is not applicable when Δf_{max} < 10 MHz.

Table 4.3.13.2.2.5-4: Medium Range BS operating band unwanted emissions limits for 1,4 MHz channel bandwidth, $P_{\text{rated,c,TRP}} \leq 40$ dBm (E-UTRA bands > 3 GHz)

Frequency offset of measurement filter -3 dB point, Δf	Frequency offset of measurement filter centre frequency, f_{offset}	Limit (notes 1 and 2)	Measurement bandwidth
$0 \text{ MHz} \leq \Delta f < 1,4 \text{ MHz}$	$0,05 \text{ MHz} \leq f_{\text{offset}} < 1,45 \text{ MHz}$	$-3 \text{ dBm} - 10/1,4(f_{\text{offset}}/\text{MHz} - 0,05) \text{ dB}$	100 kHz
$1,4 \text{ MHz} \leq \Delta f < 2,8 \text{ MHz}$	$1,45 \text{ MHz} \leq f_{\text{offset}} < 2,85 \text{ MHz}$	-13 dBm	100 kHz
$2,8 \text{ MHz} \leq \Delta f < \min(10 \text{ MHz}, \Delta f_{\text{max}})$	$2,85 \text{ MHz} \leq f_{\text{offset}} < \min(10,05 \text{ MHz}, f_{\text{offset}_{\text{max}}})$	-14 dBm (note 3)	100 kHz
$10 \text{ MHz} \leq \Delta f \leq \Delta f_{\text{max}}$	$10,05 \text{ MHz} \leq f_{\text{offset}} < f_{\text{offset}_{\text{max}}}$	-16 dBm (note 3)	100 kHz
NOTE 1: For a RIB supporting <i>non-contiguous spectrum</i> operation within any <i>operating band</i> the limit within <i>sub-block gaps</i> is calculated as a cumulative sum of contributions from adjacent sub-blocks on each side of the <i>sub-block gap</i> . Exception is $\Delta f \geq 10$ MHz from both adjacent sub-blocks on each side of the <i>sub-block gap</i> , where the limit within <i>sub-block gaps</i> shall be -16 dBm/100 kHz.			
NOTE 2: For a <i>multi-band RIB</i> with <i>Inter RF Bandwidth gap</i> $< 2 \times \Delta f_{\text{OBUE}}$ MHz the limit within the <i>Inter RF Bandwidth gaps</i> is calculated as a cumulative sum of contributions from adjacent <i>sub-blocks</i> or <i>Base Station RF Bandwidth</i> on each side of the <i>Inter RF Bandwidth gap</i> .			
NOTE 3: The requirement is not applicable when $\Delta f_{\text{max}} < 10$ MHz.			

Table 4.3.13.2.2.5-5: Medium Range BS operating band unwanted emissions limits for 3 MHz channel bandwidth, $40 < P_{\text{rated,c,TRP}} \leq 47$ dBm (E-UTRA bands ≤ 3 GHz)

Frequency offset of measurement filter -3 dB point, Δf	Frequency offset of measurement filter centre frequency, f_{offset}	Limit (notes 1 and 2)	Measurement bandwidth
$0 \text{ MHz} \leq \Delta f < 3 \text{ MHz}$	$0,05 \text{ MHz} \leq f_{\text{offset}} < 3,05 \text{ MHz}$	$P_{\text{rated,c,TRP}} - 47,2 \text{ dB} - (10/3) \times (f_{\text{offset}} - 0,05) \text{ dB}$	100 kHz
$3 \text{ MHz} \leq \Delta f < 6 \text{ MHz}$	$3,05 \text{ MHz} \leq f_{\text{offset}} < 6,05 \text{ MHz}$	$P_{\text{rated,c,TRP}} - 57,2 \text{ dB}$	100 kHz
$6 \text{ MHz} \leq \Delta f < \min(10 \text{ MHz}, \Delta f_{\text{max}})$	$6,05 \text{ MHz} \leq f_{\text{offset}} < \min(10,05 \text{ MHz}, f_{\text{offset}_{\text{max}}})$	$\text{Min}(P_{\text{rated,c,TRP}} - 57,2 \text{ dB}, -14,2 \text{ dBm})$	100 kHz
$10 \text{ MHz} \leq \Delta f \leq \Delta f_{\text{max}}$	$10,05 \text{ MHz} \leq f_{\text{offset}} < f_{\text{offset}_{\text{max}}}$	$\text{Min}(P_{\text{rated,c,TRP}} - 59 \text{ dB}, -16 \text{ dBm})$ (note 3)	100 kHz
NOTE 1: For a RIB supporting <i>non-contiguous spectrum</i> operation within any <i>operating band</i> the limit within <i>sub-block gaps</i> is calculated as a cumulative sum of contributions from adjacent sub-blocks on each side of the <i>sub-block gap</i> . Exception is $\Delta f \geq 10$ MHz from both adjacent sub-blocks on each side of the <i>sub-block gap</i> , where the limit within <i>sub-block gaps</i> shall be $\text{Min}(P_{\text{rated,c,TRP}} - 59 \text{ dB}, -16 \text{ dBm})/100$ kHz.			
NOTE 2: For a <i>multi-band RIB</i> with <i>Inter RF Bandwidth gap</i> $< 2 \times \Delta f_{\text{OBUE}}$ MHz the limit within the <i>Inter RF Bandwidth gaps</i> is calculated as a cumulative sum of contributions from adjacent <i>sub-blocks</i> or <i>Base Station RF Bandwidth</i> on each side of the <i>Inter RF Bandwidth gap</i> .			
NOTE 3: The requirement is not applicable when $\Delta f_{\text{max}} < 10$ MHz.			

Table 4.3.13.2.2.5-6: Medium Range BS operating band unwanted emissions limits for 3 MHz channel bandwidth, $40 \text{ dBm} < P_{\text{rated,c,TRP}} \leq 47$ dBm (E-UTRA bands > 3 GHz)

Frequency offset of measurement filter -3 dB point, Δf	Frequency offset of measurement filter centre frequency, f_{offset}	Limit (notes 1 and 2)	Measurement bandwidth
$0 \text{ MHz} \leq \Delta f < 3 \text{ MHz}$	$0,05 \text{ MHz} \leq f_{\text{offset}} < 3,05 \text{ MHz}$	$P_{\text{rated,c,TRP}} - 47 \text{ dB} - (10/3) \times (f_{\text{offset}} - 0,05) \text{ dB}$	100 kHz
$3 \text{ MHz} \leq \Delta f < 6 \text{ MHz}$	$3,05 \text{ MHz} \leq f_{\text{offset}} < 6,05 \text{ MHz}$	$P_{\text{rated,c,TRP}} - 57 \text{ dB}$	100 kHz
$6 \text{ MHz} \leq \Delta f < \min(10 \text{ MHz}, \Delta f_{\text{max}})$	$6,05 \text{ MHz} \leq f_{\text{offset}} < \min(10,05 \text{ MHz}, f_{\text{offset}_{\text{max}}})$	$\text{Min}(P_{\text{rated,c,TRP}} - 57 \text{ dB}, -14 \text{ dBm})$ (note 3)	100 kHz
$10 \text{ MHz} \leq \Delta f \leq \Delta f_{\text{max}}$	$10,05 \text{ MHz} \leq f_{\text{offset}} < f_{\text{offset}_{\text{max}}}$	$\text{Min}(P_{\text{rated,c,TRP}} - 59 \text{ dB}, -16 \text{ dBm})$ (note 3)	100 kHz
NOTE 1: For a RIB supporting <i>non-contiguous spectrum</i> operation within any <i>operating band</i> the limit within <i>sub-block gaps</i> is calculated as a cumulative sum of contributions from adjacent sub-blocks on each side of the <i>sub-block gap</i> . Exception is $\Delta f \geq 10$ MHz from both adjacent sub-blocks on each side of the <i>sub-block gap</i> , where the limit within <i>sub-block gaps</i> shall be $\text{Min}(P_{\text{rated,c,TRP}} - 59 \text{ dB}, -16 \text{ dBm})/100$ kHz.			
NOTE 2: For a <i>multi-band RIB</i> with <i>Inter RF Bandwidth gap</i> $< 2 \times \Delta f_{\text{OBUE}}$ MHz the limit within the <i>Inter RF Bandwidth gaps</i> is calculated as a cumulative sum of contributions from adjacent <i>sub-blocks</i> or <i>Base Station RF Bandwidth</i> on each side of the <i>Inter RF Bandwidth gap</i> .			
NOTE 3: The requirement is not applicable when $\Delta f_{\text{max}} < 10$ MHz.			

Table 4.3.13.2.2.5-7: Medium Range BS operating band unwanted emissions limits for 3 MHz channel bandwidth, $P_{\text{rated,c,TRP}} \leq 40$ dBm (E-UTRA bands ≤ 3 GHz)

Frequency offset of measurement filter -3 dB point, Δf	Frequency offset of measurement filter centre frequency, f_{offset}	Limit (notes 1 and 2)	Measurement bandwidth
$0 \text{ MHz} \leq \Delta f < 3 \text{ MHz}$	$0,05 \text{ MHz} \leq f_{\text{offset}} < 3,05 \text{ MHz}$	$-7,2 \text{ dBm} - 10/3(f_{\text{offset}}/\text{MHz}-0,05) \text{ dB}$	100 kHz
$3 \text{ MHz} \leq \Delta f < 6 \text{ MHz}$	$3,05 \text{ MHz} \leq f_{\text{offset}} < 6,05 \text{ MHz}$	-17,2 dBm	100 kHz
$6 \text{ MHz} \leq \Delta f < \min(10 \text{ MHz}, \Delta f_{\text{max}})$	$6,05 \text{ MHz} \leq f_{\text{offset}} < \min(10,05 \text{ MHz}, f_{\text{offset}_{\text{max}}})$	-17,2 dBm (note 3)	100 kHz
$10 \text{ MHz} \leq \Delta f \leq \Delta f_{\text{max}}$	$10,05 \text{ MHz} \leq f_{\text{offset}} < f_{\text{offset}_{\text{max}}}$	-19 dBm (note 3)	100 kHz
NOTE 1: For a RIB supporting <i>non-contiguous spectrum</i> operation within any <i>operating band</i> the limit within <i>sub-block gaps</i> is calculated as a cumulative sum of contributions from adjacent sub-blocks on each side of the <i>sub-block gap</i> . Exception is $\Delta f \geq 10$ MHz from both adjacent sub-blocks on each side of the <i>sub-block gap</i> , where the limit within <i>sub-block gaps</i> shall be -19 dBm/100 kHz.			
NOTE 2: For a <i>multi-band RIB</i> with <i>Inter RF Bandwidth gap</i> $< 2 \times \Delta f_{\text{OBUE}}$ MHz the limit within the <i>Inter RF Bandwidth gaps</i> is calculated as a cumulative sum of contributions from adjacent <i>sub-blocks</i> or <i>Base Station RF Bandwidth</i> on each side of the <i>Inter RF Bandwidth gap</i> .			
NOTE 3: The requirement is not applicable when $\Delta f_{\text{max}} < 10$ MHz.			

Table 4.3.13.2.2.5-8: Medium Range BS operating band unwanted emissions limits for 3 MHz channel bandwidth, $P_{\text{rated,c,TRP}} \leq 40$ dBm (E-UTRA bands > 3 GHz)

Frequency offset of measurement filter -3 dB point, Δf	Frequency offset of measurement filter centre frequency, f_{offset}	Limit (notes 1 and 2)	Measurement bandwidth
$0 \text{ MHz} \leq \Delta f < 3 \text{ MHz}$	$0,05 \text{ MHz} \leq f_{\text{offset}} < 3,05 \text{ MHz}$	$-7 \text{ dBm} - 10/3(f_{\text{offset}}/\text{MHz}-0,05) \text{ dB}$	100 kHz
$3 \text{ MHz} \leq \Delta f < 6 \text{ MHz}$	$3,05 \text{ MHz} \leq f_{\text{offset}} < 6,05 \text{ MHz}$	-17 dBm	100 kHz
$6 \text{ MHz} \leq \Delta f < \min(10 \text{ MHz}, \Delta f_{\text{max}})$	$6,05 \text{ MHz} \leq f_{\text{offset}} < \min(10,05 \text{ MHz}, f_{\text{offset}_{\text{max}}})$	-17 dBm (note 3)	100 kHz
$10 \text{ MHz} \leq \Delta f \leq \Delta f_{\text{max}}$	$10,05 \text{ MHz} \leq f_{\text{offset}} < f_{\text{offset}_{\text{max}}}$	-19 dBm (note 3)	100 kHz
NOTE 1: For a RIB supporting <i>non-contiguous spectrum</i> operation within any <i>operating band</i> the limit within <i>sub-block gaps</i> is calculated as a cumulative sum of contributions from adjacent sub-blocks on each side of the <i>sub-block gap</i> . Exception is $\Delta f \geq 10$ MHz from both adjacent sub-blocks on each side of the <i>sub-block gap</i> , where the limit within <i>sub-block gaps</i> shall be -19 dBm/100 kHz.			
NOTE 2: For a <i>multi-band RIB</i> with <i>Inter RF Bandwidth gap</i> $< 2 \times \Delta f_{\text{OBUE}}$ MHz the limit within the <i>Inter RF Bandwidth gaps</i> is calculated as a cumulative sum of contributions from adjacent <i>sub-blocks</i> or <i>Base Station RF Bandwidth</i> on each side of the <i>Inter RF Bandwidth gap</i> .			
NOTE 3: The requirement is not applicable when $\Delta f_{\text{max}} < 10$ MHz.			

Table 4.3.13.2.2.5-9: Medium Range BS operating band unwanted emissions limits for 5 MHz, 10 MHz, 15 MHz and 20 MHz channel bandwidth, $40 \text{ dBm} < P_{\text{rated,c,TRP}} \leq 47$ dBm (E-UTRA bands ≤ 3 GHz)

Frequency offset of measurement filter -3 dB point, Δf	Frequency offset of measurement filter centre frequency, f_{offset}	Limit (notes 1 and 2)	Measurement bandwidth
$0 \text{ MHz} \leq \Delta f < 5 \text{ MHz}$	$0,05 \text{ MHz} \leq f_{\text{offset}} < 5,05 \text{ MHz}$	$P_{\text{rated,c,TRP}} - 51,2 \text{ dB} - (7/5) \times (f_{\text{offset}} - 0,05) \text{ dB}$	100 kHz
$5 \text{ MHz} \leq \Delta f < \min(10 \text{ MHz}, \Delta f_{\text{max}})$	$5,05 \text{ MHz} \leq f_{\text{offset}} < \min(10,05 \text{ MHz}, f_{\text{offset}_{\text{max}}})$	$P_{\text{rated,c,TRP}} - 58,2 \text{ dB}$	100 kHz
$10 \text{ MHz} \leq \Delta f \leq \Delta f_{\text{max}}$	$10,05 \text{ MHz} \leq f_{\text{offset}} < f_{\text{offset}_{\text{max}}}$	$\text{Min}(P_{\text{rated,c,TRP}} - 60 \text{ dB}, -16 \text{ dBm})$ (note 3)	100 kHz
NOTE 1: For a RIB supporting <i>non-contiguous spectrum</i> operation within any <i>operating band</i> the limit within <i>sub-block gaps</i> is calculated as a cumulative sum of contributions from adjacent sub-blocks on each side of the <i>sub-block gap</i> . Exception is $\Delta f \geq 10$ MHz from both adjacent sub-blocks on each side of the <i>sub-block gap</i> , where the limit within <i>sub-block gaps</i> shall be $\text{Min}(P_{\text{rated,c,TRP}} - 60 \text{ dB}, -16 \text{ dBm})/100$ kHz.			
NOTE 2: For a <i>multi-band RIB</i> with <i>Inter RF Bandwidth gap</i> $< 2 \times \Delta f_{\text{OBUE}}$ MHz the limit within the <i>Inter RF Bandwidth gaps</i> is calculated as a cumulative sum of contributions from adjacent <i>sub-blocks</i> or <i>Base Station RF Bandwidth</i> on each side of the <i>Inter RF Bandwidth gap</i> .			
NOTE 3: The requirement is not applicable when $\Delta f_{\text{max}} < 10$ MHz.			

Table 4.3.13.2.2.5-10: Medium Range BS operating band unwanted emissions limits for 5 MHz, 10 MHz, 15 MHz and 20 MHz channel bandwidth, 40 dBm < P_{rated,c,TRP} ≤ 47 dBm (E-UTRA bands > 3 GHz)

Frequency offset of measurement filter -3 dB point, Δf	Frequency offset of measurement filter centre frequency, f _{offset}	Limit (notes 1 and 2)	Measurement bandwidth
0 MHz ≤ Δf < 5 MHz	0,05 MHz ≤ f _{offset} < 5,05 MHz	P _{rated,c,TRP} - 51 dB-(7/5)×(f _{offset} -0,05) dB	100 kHz
5 MHz ≤ Δf < min(10 MHz, Δf _{max})	5,05 MHz ≤ f _{offset} < min(10,05 MHz, f _{offsetmax})	P _{rated,c,TRP} - 58 dB	100 kHz
10 MHz ≤ Δf ≤ Δf _{max}	10,05 MHz ≤ f _{offset} < f _{offsetmax}	Min(P _{rated,c,TRP} - 60 dB, -16 dBm) (note 3)	100 kHz

NOTE 1: For a RIB supporting *non-contiguous spectrum* operation within any *operating band* the limit within *sub-block gaps* is calculated as a cumulative sum of contributions from adjacent sub-blocks on each side of the *sub-block gap*. Exception is Δf ≥ 10 MHz from both adjacent sub-blocks on each side of the *sub-block gap*, where the limit within *sub-block gaps* shall be Min(P_{rated,c,TRP} -60 dB, -16 dBm)/100 kHz.

NOTE 2: For a *multi-band RIB* with *Inter RF Bandwidth gap* < 2 × Δf_{OBUE} MHz the limit within the *Inter RF Bandwidth gaps* is calculated as a cumulative sum of contributions from adjacent *sub-blocks* or *Base Station RF Bandwidth* on each side of the *Inter RF Bandwidth gap*.

NOTE 3: The requirement is not applicable when Δf_{max} < 10 MHz.

Table 4.3.13.2.2.5-11: Medium Range BS operating band unwanted emissions limits for 5 MHz, 10 MHz, 15 MHz and 20 MHz channel bandwidth, P_{rated,c,TRP} ≤ 40 dBm (E-UTRA bands ≤ 3 GHz)

Frequency offset of measurement filter -3 dB point, Δf	Frequency offset of measurement filter centre frequency, f _{offset}	Limit (notes 1 and 2)	Measurement bandwidth
0 MHz ≤ Δf < 5 MHz	0,05 MHz ≤ f _{offset} < 5,05 MHz	P _{rated,c,TRP} - 11,2 dB-(7/5)×(f _{offset} -0,05) dB	100 kHz
5 MHz ≤ Δf < min(10 MHz, Δf _{max})	5,05 MHz ≤ f _{offset} < min(10,05 MHz, f _{offsetmax})	-18,2 dBm	100 kHz
10 MHz ≤ Δf ≤ Δf _{max}	10,05 MHz ≤ f _{offset} < f _{offsetmax}	-20 dBm (note 3)	100 kHz

NOTE 1: For a RIB supporting *non-contiguous spectrum* operation within any *operating band* the limit within *sub-block gaps* is calculated as a cumulative sum of contributions from adjacent sub-blocks on each side of the *sub-block gap*. Exception is Δf ≥ 10 MHz from both adjacent sub-blocks on each side of the *sub-block gap*, where the limit within *sub-block gaps* shall be -20 dBm/100 kHz.

NOTE 2: For a *multi-band RIB* with *Inter RF Bandwidth gap* < 2 × Δf_{OBUE} MHz the limit within the *Inter RF Bandwidth gaps* is calculated as a cumulative sum of contributions from adjacent *sub-blocks* or *Base Station RF Bandwidth* on each side of the *Inter RF Bandwidth gap*.

NOTE 3: The requirement is not applicable when Δf_{max} < 10 MHz.

Table 4.3.13.2.2.5-12: Medium Range BS operating band unwanted emissions limits for 5 MHz, 10 MHz, 15 MHz and 20 MHz channel bandwidth, P_{rated,c,TRP} ≤ 40 dBm (E-UTRA bands > 3 GHz)

Frequency offset of measurement filter -3 dB point, Δf	Frequency offset of measurement filter centre frequency, f _{offset}	Limit (notes 1 and 2)	Measurement bandwidth
0 MHz ≤ Δf < 5 MHz	0,05 MHz ≤ f _{offset} < 5,05 MHz	P _{rated,c,TRP} - 11 dB-(7/5)×(f _{offset} -0,05) dB	100 kHz
5 MHz ≤ Δf < min(10 MHz, Δf _{max})	5,05 MHz ≤ f _{offset} < min(10,05 MHz, f _{offsetmax})	-18 dBm	100 kHz
10 MHz ≤ Δf ≤ Δf _{max}	10,05 MHz ≤ f _{offset} < f _{offsetmax}	-20 dBm (note 3)	100 kHz

NOTE 1: For a RIB supporting *non-contiguous spectrum* operation within any *operating band* the limit within *sub-block gaps* is calculated as a cumulative sum of contributions from adjacent sub-blocks on each side of the *sub-block gap*. Exception is Δf ≥ 10 MHz from both adjacent sub-blocks on each side of the *sub-block gap*, where the limit within *sub-block gaps* shall be -20 dBm/100 kHz.

NOTE 2: For a *multi-band RIB* with *Inter RF Bandwidth gap* < 2 × Δf_{OBUE} MHz the limit within the *Inter RF Bandwidth gaps* is calculated as a cumulative sum of contributions from adjacent *sub-blocks* or *Base Station RF Bandwidth* on each side of the *Inter RF Bandwidth gap*.

NOTE 3: The requirement is not applicable when Δf_{max} < 10 MHz.

4.3.13.2.2.6 Local Area BS

For an Local Area BS in E-UTRA bands ≤ 3 GHz, emissions shall not exceed the limits specified in tables 4.3.13.2.2.6-1, 4.3.13.2.2.6-3 and 4.3.13.2.2.6-5.

For an Local Area BS in E-UTRA bands > 3 GHz, emissions shall not exceed the limits specified in tables 4.3.13.2.2.6-2, 4.3.13.2.2.6-4 and 4.3.13.2.2.6-6.

Table 4.3.13.2.2.6-1: Local Area BS operating band unwanted emissions limits for 1,4 MHz channel bandwidth (E-UTRA bands ≤ 3 GHz)

Frequency offset of measurement filter -3 dB point, Δf	Frequency offset of measurement filter centre frequency, f_{offset}	Limit (notes 1 and 2)	Measurement bandwidth
$0 \text{ MHz} \leq \Delta f < 1,4 \text{ MHz}$	$0,05 \text{ MHz} \leq f_{\text{offset}} < 1,45 \text{ MHz}$	$-10,2 \text{ dBm} - 10/1,4(f_{\text{offset}}/\text{MHz}-0,05) \text{ dB}$	100 kHz
$1,4 \text{ MHz} \leq \Delta f < 2,8 \text{ MHz}$	$1,45 \text{ MHz} \leq f_{\text{offset}} < 2,85 \text{ MHz}$	-20,2 dBm	100 kHz
$2,8 \text{ MHz} \leq \Delta f < \min(10 \text{ MHz}, \Delta f_{\text{max}})$	$2,85 \text{ MHz} \leq f_{\text{offset}} < \min(10,05 \text{ MHz}, f_{\text{offset}_{\text{max}}})$	-20,2 dBm (note 3)	100 kHz
$10 \text{ MHz} \leq \Delta f \leq \Delta f_{\text{max}}$	$10,05 \text{ MHz} \leq f_{\text{offset}} < f_{\text{offset}_{\text{max}}}$	-22 dBm (note 3)	100 kHz

NOTE 1: For a RIB supporting *non-contiguous spectrum* operation within any *operating band* the limit within *sub-block gaps* is calculated as a cumulative sum of contributions from adjacent sub-blocks on each side of the *sub-block gap*. Exception is $\Delta f \geq 10$ MHz from both adjacent sub-blocks on each side of the *sub-block gap*, where the limit within *sub-block gaps* shall be -22 dBm/100 kHz.

NOTE 2: For a *multi-band RIB* with *Inter RF Bandwidth gap* $< 2 \times \Delta f_{\text{OBUE}}$ MHz the limit within the *Inter RF Bandwidth gaps* is calculated as a cumulative sum of contributions from adjacent *sub-blocks* or *Base Station RF Bandwidth* on each side of the *Inter RF Bandwidth gap*.

NOTE 3: The requirement is not applicable when $\Delta f_{\text{max}} < 10$ MHz.

Table 4.3.13.2.2.6-2: Local Area BS operating band unwanted emissions limits for 1,4 MHz channel bandwidth (E-UTRA bands > 3 GHz)

Frequency offset of measurement filter -3 dB point, Δf	Frequency offset of measurement filter centre frequency, f_{offset}	Limit (notes 1 and 2)	Measurement bandwidth
$0 \text{ MHz} \leq \Delta f < 1,4 \text{ MHz}$	$0,05 \text{ MHz} \leq f_{\text{offset}} < 1,45 \text{ MHz}$	$-10 \text{ dBm} - 10/1,4(f_{\text{offset}}/\text{MHz}-0,05) \text{ dB}$	100 kHz
$1,4 \text{ MHz} \leq \Delta f < 2,8 \text{ MHz}$	$1,45 \text{ MHz} \leq f_{\text{offset}} < 2,85 \text{ MHz}$	-20 dBm	100 kHz
$2,8 \text{ MHz} \leq \Delta f < \min(10 \text{ MHz}, \Delta f_{\text{max}})$	$2,85 \text{ MHz} \leq f_{\text{offset}} < \min(10,05 \text{ MHz}, f_{\text{offset}_{\text{max}}})$	-20 dBm (note 3)	100 kHz
$10 \text{ MHz} \leq \Delta f \leq \Delta f_{\text{max}}$	$10,05 \text{ MHz} \leq f_{\text{offset}} < f_{\text{offset}_{\text{max}}}$	-22 dBm (note 3)	100 kHz

NOTE 1: For a RIB supporting *non-contiguous spectrum* operation within any *operating band* the limit within *sub-block gaps* is calculated as a cumulative sum of contributions from adjacent sub-blocks on each side of the *sub-block gap*. Exception is $\Delta f \geq 10$ MHz from both adjacent sub-blocks on each side of the *sub-block gap*, where the limit within *sub-block gaps* shall be -22 dBm/100 kHz.

NOTE 2: For a *multi-band RIB* with *Inter RF Bandwidth gap* $< 2 \times \Delta f_{\text{OBUE}}$ MHz the limit within the *Inter RF Bandwidth gaps* is calculated as a cumulative sum of contributions from adjacent *sub-blocks* or *Base Station RF Bandwidth* on each side of the *Inter RF Bandwidth gap*.

NOTE 3: The requirement is not applicable when $\Delta f_{\text{max}} < 10$ MHz.

Table 4.3.13.2.2.6-3: Local Area BS operating band unwanted emissions limits for 3 MHz channel bandwidth (E-UTRA bands ≤ 3 GHz)

Frequency offset of measurement filter -3 dB point, Δf	Frequency offset of measurement filter centre frequency, f_{offset}	Limit (notes 1 and 2)	Measurement bandwidth
$0 \text{ MHz} \leq \Delta f < 3 \text{ MHz}$	$0,05 \text{ MHz} \leq f_{\text{offset}} < 3,05 \text{ MHz}$	$-14,2 \text{ dBm} - 10/3(f_{\text{offset}}/\text{MHz}-0,05) \text{ dB}$	100 kHz
$3 \text{ MHz} \leq \Delta f < 6 \text{ MHz}$	$3,05 \text{ MHz} \leq f_{\text{offset}} < 6,05 \text{ MHz}$	-24,2 dBm	100 kHz
$6 \text{ MHz} \leq \Delta f < \min(10 \text{ MHz}, \Delta f_{\text{max}})$	$6,05 \text{ MHz} \leq f_{\text{offset}} < \min(10,05 \text{ MHz}, f_{\text{offset}_{\text{max}}})$	-24,2 dBm (note 3)	100 kHz
$10 \text{ MHz} \leq \Delta f \leq \Delta f_{\text{max}}$	$10,05 \text{ MHz} \leq f_{\text{offset}} < f_{\text{offset}_{\text{max}}}$	-26 dBm (note 3)	100 kHz

NOTE 1: For a RIB supporting *non-contiguous spectrum* operation within any *operating band* the limit within *sub-block gaps* is calculated as a cumulative sum of contributions from adjacent sub-blocks on each side of the *sub-block gap*. Exception is $\Delta f \geq 10 \text{ MHz}$ from both adjacent sub-blocks on each side of the *sub-block gap*, where the limit within *sub-block gaps* shall be -26 dBm/100 kHz.

NOTE 2: For a *multi-band RIB* with *Inter RF Bandwidth gap* $< 2 \times \Delta f_{\text{OBUE}}$ MHz the limit within the *Inter RF Bandwidth gaps* is calculated as a cumulative sum of contributions from adjacent *sub-blocks* or *Base Station RF Bandwidth* on each side of the *Inter RF Bandwidth gap*.

NOTE 3: The requirement is not applicable when $\Delta f_{\text{max}} < 10 \text{ MHz}$.

Table 4.3.13.2.2.6-4: Local Area BS operating band unwanted emissions limits for 3 MHz channel bandwidth (E-UTRA bands > 3 GHz)

Frequency offset of measurement filter -3 dB point, Δf	Frequency offset of measurement filter centre frequency, f_{offset}	Limit (notes 1 and 2)	Measurement bandwidth
$0 \text{ MHz} \leq \Delta f < 3 \text{ MHz}$	$0,05 \text{ MHz} \leq f_{\text{offset}} < 3,05 \text{ MHz}$	$-14 \text{ dBm} - 10/3(f_{\text{offset}}/\text{MHz}-0,05) \text{ dB}$	100 kHz
$3 \text{ MHz} \leq \Delta f < 6 \text{ MHz}$	$3,05 \text{ MHz} \leq f_{\text{offset}} < 6,05 \text{ MHz}$	-24 dBm	100 kHz
$6 \text{ MHz} \leq \Delta f < \min(10 \text{ MHz}, \Delta f_{\text{max}})$	$6,05 \text{ MHz} \leq f_{\text{offset}} < \min(10,05 \text{ MHz}, f_{\text{offset}_{\text{max}}})$	-24 dBm (note 3)	100 kHz
$10 \text{ MHz} \leq \Delta f \leq \Delta f_{\text{max}}$	$10,05 \text{ MHz} \leq f_{\text{offset}} < f_{\text{offset}_{\text{max}}}$	-26 dBm (note 3)	100 kHz

NOTE 1: For a RIB supporting *non-contiguous spectrum* operation within any *operating band* the limit within *sub-block gaps* is calculated as a cumulative sum of contributions from adjacent sub-blocks on each side of the *sub-block gap*. Exception is $\Delta f \geq 10 \text{ MHz}$ from both adjacent sub-blocks on each side of the *sub-block gap*, where the limit within *sub-block gaps* shall be -26 dBm/100 kHz.

NOTE 2: For a *multi-band RIB* with *Inter RF Bandwidth gap* $< 2 \times \Delta f_{\text{OBUE}}$ MHz the limit within the *Inter RF Bandwidth gaps* is calculated as a cumulative sum of contributions from adjacent *sub-blocks* or *Base Station RF Bandwidth* on each side of the *Inter RF Bandwidth gap*.

NOTE 3: The requirement is not applicable when $\Delta f_{\text{max}} < 10 \text{ MHz}$.

Table 4.3.13.2.2.6-5: Local Area BS operating band unwanted emissions limits for 5 MHz, 10 MHz, 15 MHz and 20 MHz channel bandwidth (E-UTRA bands ≤ 3 GHz)

Frequency offset of measurement filter -3 dB point, Δf	Frequency offset of measurement filter centre frequency, f_{offset}	Limit (notes 1 and 2)	Measurement bandwidth
$0 \text{ MHz} \leq \Delta f < 5 \text{ MHz}$	$0,05 \text{ MHz} \leq f_{\text{offset}} < 5,05 \text{ MHz}$	$-19,2 \text{ dBm} - 7/5(f_{\text{offset}}/\text{MHz}-0,05) \text{ dB}$	100 kHz
$5 \text{ MHz} \leq \Delta f < \min(10 \text{ MHz}, \Delta f_{\text{max}})$	$5,05 \text{ MHz} \leq f_{\text{offset}} < \min(10,05 \text{ MHz}, f_{\text{offset}_{\text{max}}})$	-26,2 dBm	100 kHz
$10 \text{ MHz} \leq \Delta f \leq \Delta f_{\text{max}}$	$10,05 \text{ MHz} \leq f_{\text{offset}} < f_{\text{offset}_{\text{max}}}$	-28 dBm (note 3)	100 kHz

NOTE 1: For a RIB supporting *non-contiguous spectrum* operation within any *operating band* the limit within *sub-block gaps* is calculated as a cumulative sum of contributions from adjacent sub-blocks on each side of the *sub-block gap*. Exception is $\Delta f \geq 10 \text{ MHz}$ from both adjacent sub-blocks on each side of the *sub-block gap*, where the limit within *sub-block gaps* shall be -28 dBm/100 kHz.

NOTE 2: For a *multi-band RIB* with *Inter RF Bandwidth gap* $< 2 \times \Delta f_{\text{OBUE}}$ MHz the limit within the *Inter RF Bandwidth gaps* is calculated as a cumulative sum of contributions from adjacent *sub-blocks* or *Base Station RF Bandwidth* on each side of the *Inter RF Bandwidth gap*.

NOTE 3: The requirement is not applicable when $\Delta f_{\text{max}} < 10 \text{ MHz}$.

Table 4.3.13.2.2.6-6: Local Area BS operating band unwanted emissions limits for 5 MHz, 10 MHz, 15 MHz and 20 MHz channel bandwidth (E-UTRA bands > 3 GHz)

Frequency offset of measurement filter -3 dB point, Δf	Frequency offset of measurement filter centre frequency, f_{offset}	Limit (notes 1 and 2)	Measurement bandwidth
$0 \text{ MHz} \leq \Delta f < 5 \text{ MHz}$	$0,05 \text{ MHz} \leq f_{\text{offset}} < 5,05 \text{ MHz}$	$-19 \text{ dBm} - 7/5(f_{\text{offset}}/\text{MHz} - 0,05) \text{ dB}$	100 kHz
$5 \text{ MHz} \leq \Delta f < \min(10 \text{ MHz}, \Delta f_{\text{max}})$	$5,05 \text{ MHz} \leq f_{\text{offset}} < \min(10,05 \text{ MHz}, f_{\text{offset}_{\text{max}}})$	-26 dBm	100 kHz
$10 \text{ MHz} \leq \Delta f \leq \Delta f_{\text{max}}$	$10,05 \text{ MHz} \leq f_{\text{offset}} < f_{\text{offset}_{\text{max}}}$	-28 dBm (note 3)	100 kHz

NOTE 1: For a RIB supporting *non-contiguous spectrum* operation within any *operating band* the limit within *sub-block gaps* is calculated as a cumulative sum of contributions from adjacent sub-blocks on each side of the *sub-block gap*. Exception is $\Delta f \geq 10 \text{ MHz}$ from both adjacent sub-blocks on each side of the *sub-block gap*, where the limit within *sub-block gaps* shall be -28 dBm/100 kHz.

NOTE 2: For BS a *multi-band RIB* with *Inter RF Bandwidth gap* $< 2 \times \Delta f_{\text{OBUe}}$ MHz the limit within the *Inter RF Bandwidth gaps* is calculated as a cumulative sum of contributions from adjacent *sub-blocks* or *Base Station RF Bandwidth* on each side of the *Inter RF Bandwidth gap*.

NOTE 3: The requirement is not applicable when $\Delta f_{\text{max}} < 10 \text{ MHz}$.

4.3.13.2.2.7 Additional Requirements

For co-existence with FSS/FS the emissions for BS operating in bands 77 and 78, shall not exceed the limits specified in table 4.3.13.2.2.7-1.

Table 4.3.13.2.2.7-1: Additional operating band unwanted emissions limits for bands 77 and 78

Frequency range	Limit	Measurement bandwidth
3 800 MHz to 3 805 MHz	$\text{Min}(P_{\text{rated,t,TRP}} - 40, 16) \text{ dBm}$	5 MHz
3 805 MHz to 3 810 MHz	$\text{Min}(P_{\text{rated,t,TRP}} - 43, 12) \text{ dBm}$	5 MHz
3 810 MHz to 3 840 MHz	$\text{Min}(P_{\text{rated,t,TRP}} - 43, 1) \text{ dBm}$	5 MHz
Above 3 840 MHz	-14 dBm	5 MHz

For protection of systems above 2 400 MHz, the total radiated power of unwanted emissions above 2 403 MHz for BS operating in band 40 shall not exceed the limits specified in table 4.3.13.2.2.7-2.

Table 4.3.13.2.2.7-2: Additional operating band unwanted emission limits for BS operating in band 40

Frequency range	Rated transmitter TRP $P_{\text{rated,t,TRP}}$	Limit	Measurement bandwidth
Above 2 403 MHz	$P_{\text{rated,t,TRP}} > 47 \text{ dBm}$	-13 dBm	5 MHz
	$33 \text{ dBm} < P_{\text{rated,t,TRP}} \leq 47 \text{ dBm}$	$P_{\text{rated,t,TRP}} - 60 \text{ dBm}$	5 MHz
	$P_{\text{rated,t,TRP}} \leq 33 \text{ dBm}$	-27 dBm	5 MHz

NOTE: For a BS operating in band 20, additional limits for protection of DTT are described in clause 6.7.5.5.5.7 of ETSI TS 137 145-2 [3]. This statement is provided for information and does not have any impact on the conformance requirements or essential radio test suites in the present document.

For BS operating in bands 32, 75 and 76 additional unwanted emission limits described in clause 4.3.13.2.1.4 shall also apply.

4.3.13.3 Conformance

The conformance tests for this requirement shall be as defined in clause 5.3.13 of the present document.

4.3.14 OTA Spectrum Emission Mask (OTA SEM)

4.3.14.1 Definition and applicability

This requirement applies for RIBs supporting only *single RAT UTRA operation*.

The spectrum emission mask limits are expressed as TRP.

4.3.14.2 Limits

The emissions shall not exceed the *basic limits* specified in tables below for the appropriate $P_{\text{rated,c,TRP}}$, where:

- Δf is the separation between the carrier frequency and the nominal -3 dB point of the measuring filter closest to the carrier frequency.
- f_{offset} is the separation between the carrier frequency and the centre of the measurement filter.
- $f_{\text{offset}_{\text{max}}}$ is either 12,5 MHz or the offset to the UMTS Tx band edge as defined in clause 3.4.1 in ETSI TS 125 141 [7], whichever is the greater.
- Δf_{max} is equal to $f_{\text{offset}_{\text{max}}}$ minus half of the bandwidth of the measuring filter.

Inside any *Inter RF Bandwidth gaps* with $W_{\text{gap}} < 2 \times \Delta f_{\text{OBUE}}$ for a *multi-band RIB*, emissions shall not exceed the cumulative sum of the *basic limits* specified at the *Base Station RF Bandwidth edges* on each side of the *Inter RF Bandwidth gap*. The *basic limit* for *Base Station RF Bandwidth edge* is specified in tables below, where in this case:

- Δf is equal to 2,5 MHz plus the separation between the *Base Station RF Bandwidth edge* frequency and the nominal -3 dB point of the measuring filter closest to the *Base Station RF Bandwidth edge*.
- f_{offset} is equal to 2,5 MHz plus the separation between the *Base Station RF Bandwidth edge* frequency and the centre of the measuring filter.
- $f_{\text{offset}_{\text{max}}}$ is either 12,5 MHz or the offset to the UMTS Tx band edge, whichever is the greater.
- Δf_{max} is equal to $f_{\text{offset}_{\text{max}}}$ minus half of the bandwidth of the measuring filter.

For a *multi-band RIB*, the *operating band unwanted emission basic limits* apply also in a supported *operating band* without any carrier transmitted, in the case where there are carrier(s) transmitted in another supported *operating band*. In this case, no cumulative limit is applied in the *inter-band gap* between a supported *downlink operating band* with carrier(s) transmitted and a supported *downlink operating band* without any carrier transmitted; and:

- In case the *inter-band gap* between a downlink band with carrier(s) transmitted and a downlink band without any carrier transmitted is less than $2 \times \Delta f_{\text{OBUE}}$, $f_{\text{offset}_{\text{max}}}$ shall be the offset to the frequency Δf_{OBUE} outside the outermost edges of the two *downlink operating bands* and the *operating band unwanted emission basic limit* of the band where there are carriers transmitted, as defined in the tables of the present clause, shall apply across both downlink bands.
- In other cases, the *operating band unwanted emission basic limit* of the band where there are carriers transmitted, as defined in the tables of the present clause for the largest frequency offset (Δf_{max}), shall apply from Δf_{OBUE} below the lowest frequency, up to Δf_{OBUE} above the highest frequency of the *downlink operating band* without any carrier transmitted;

Inside any *sub-block gap* for a RIB operating in *non-contiguous spectrum*, emissions shall not exceed the cumulative sum of the *basic limits* specified for the adjacent sub-blocks on each side of the *sub-block gap*. The *basic limit* for each sub-block is specified in tables below, where in this case:

- Δf is equal to 2,5 MHz plus the separation between the sub-block edge frequency and the nominal -3 dB point of the measuring filter closest to the sub-block edge.
- f_{offset} is equal to 2,5 MHz plus the separation between the sub-block edge frequency and the centre of the measuring filter.

- $f_{\text{offset,max}}$ is equal to the *sub-block gap* bandwidth minus half of the bandwidth of the measuring filter plus 2,5 MHz.
- Δf_{max} is equal to $f_{\text{offset,max}}$ minus half of the bandwidth of the measuring filter.

Table 4.3.14.2-1: Spectrum emission mask, $P_{\text{rated,c,TRP}} \geq 49$ dBm for UTRA bands ≤ 3 GHz

Frequency offset of measurement filter -3 dB point, Δf	Frequency offset of measurement filter centre frequency, f_{offset}	Basic limit (notes 1 and 2)	Measurement bandwidth
$2,5 \text{ MHz} \leq \Delta f < 2,7 \text{ MHz}$	$2,515 \text{ MHz} \leq f_{\text{offset}} < 2,715 \text{ MHz}$	-6,2 dBm	30 kHz
$2,7 \text{ MHz} \leq \Delta f < 3,5 \text{ MHz}$	$2,715 \text{ MHz} \leq f_{\text{offset}} < 3,515 \text{ MHz}$	$-6,2 + 15(f_{\text{offset}}/\text{MHz} - 2,715) \text{ dBm}$	30 kHz
(note 3)	$3,515 \text{ MHz} \leq f_{\text{offset}} < 4,0 \text{ MHz}$	-18,2 dBm	30 kHz
$3,5 \text{ MHz} \leq \Delta f < 7,5 \text{ MHz}$	$4,0 \text{ MHz} \leq f_{\text{offset}} < 8,0 \text{ MHz}$	-5,2 dBm	1 MHz
$7,5 \text{ MHz} \leq \Delta f \leq \Delta f_{\text{max}}$	$8,0 \text{ MHz} \leq f_{\text{offset}} < f_{\text{offset,max}}$	-5,2 dBm	1 MHz

NOTE 1: For a RIB supporting *non-contiguous spectrum* operation the *basic limit* within *sub-block gaps* within any *operating band* is calculated as a cumulative sum of contributions from adjacent sub-blocks on each side of the *sub-block gap*, where the contribution from the far-end *sub-block* shall be scaled according to the *measurement bandwidth* of the near-end *sub-block*. Exception is $\Delta f \geq 12,5$ MHz from both adjacent *sub-blocks* on each side of the *sub-block gap*, where *basic limit* shall be -5,2 dBm/MHz.

NOTE 2: For a *multi-band RIB* with *Inter RF Bandwidth gap* $< 2 \times \Delta f_{\text{OBUE}}$ the *basic limit* within the *Inter RF Bandwidth gaps* is calculated as a cumulative sum of contributions from adjacent *sub-blocks* or RF Bandwidth on each side of the *Inter RF Bandwidth gap*, where the contribution from the far-end *sub-block* or *Base Station RF Bandwidth* shall be scaled according to the *measurement bandwidth* of the near-end *sub-block* or *Base Station RF Bandwidth*.

NOTE 3: This frequency range ensures that the range of values of f_{offset} is continuous.

Table 4.3.14.2-2: Spectrum emission mask, $P_{\text{rated,c,TRP}} \geq 49$ dBm for UTRA bands > 3 GHz

Frequency offset of measurement filter -3 dB point, Δf	Frequency offset of measurement filter centre frequency, f_{offset}	Basic limit (notes 1 and 2)	Measurement bandwidth
$2,5 \text{ MHz} \leq \Delta f < 2,7 \text{ MHz}$	$2,515 \text{ MHz} \leq f_{\text{offset}} < 2,715 \text{ MHz}$	-6 dBm	30 kHz
$2,7 \text{ MHz} \leq \Delta f < 3,5 \text{ MHz}$	$2,715 \text{ MHz} \leq f_{\text{offset}} < 3,515 \text{ MHz}$	$-6 + 15(f_{\text{offset}}/\text{MHz} - 2,715) \text{ dBm}$	30 kHz
(note 3)	$3,515 \text{ MHz} \leq f_{\text{offset}} < 4,0 \text{ MHz}$	-18 dBm	30 kHz
$3,5 \text{ MHz} \leq \Delta f < 7,5 \text{ MHz}$	$4,0 \text{ MHz} \leq f_{\text{offset}} < 8,0 \text{ MHz}$	-5 dBm	1 MHz
$7,5 \text{ MHz} \leq \Delta f \leq \Delta f_{\text{max}}$	$8,0 \text{ MHz} \leq f_{\text{offset}} < f_{\text{offset,max}}$	-5 dBm	1 MHz

NOTE 1: For a RIB supporting *non-contiguous spectrum* operation the *basic limit* within *sub-block gaps* within any *operating band* is calculated as a cumulative sum of contributions from adjacent sub-blocks on each side of the *sub-block gap*, where the contribution from the far-end *sub-block* shall be scaled according to the *measurement bandwidth* of the near-end *sub-block*. Exception is $\Delta f \geq 12,5$ MHz from both adjacent *sub-blocks* on each side of the *sub-block gap*, where the *basic limit* is -5 dBm/MHz.

NOTE 2: For a *multi-band RIB* with *Inter RF Bandwidth gap* $< 2 \times \Delta f_{\text{OBUE}}$ the *basic limit* within the *Inter RF Bandwidth gaps* is calculated as a cumulative sum of contributions from adjacent *sub-blocks* or *Base Station RF Bandwidth* on each side of the *Inter RF Bandwidth gap*, where the contribution from the far-end *sub-block* or *Base Station RF Bandwidth* shall be scaled according to the *measurement bandwidth* of the near-end *sub-block* or *Base Station RF Bandwidth*.

NOTE 3: This frequency range ensures that the range of values of f_{offset} is continuous.

Table 4.3.14.2-3: Spectrum emission mask, $45 \text{ dBm} \leq P_{\text{rated,c,TRP}} < 49 \text{ dBm}$ for UTRA bands $\leq 3 \text{ GHz}$

Frequency offset of measurement filter -3 dB point, Δf	Frequency offset of measurement filter centre frequency, f_{offset}	Basic limit (notes 1 and 2)	Measurement bandwidth
$2,5 \text{ MHz} \leq \Delta f < 2,7 \text{ MHz}$	$2,515 \text{ MHz} \leq f_{\text{offset}} < 2,715 \text{ MHz}$	-6,2 dBm	30 kHz
$2,7 \text{ MHz} \leq \Delta f < 3,5 \text{ MHz}$	$2,715 \text{ MHz} \leq f_{\text{offset}} < 3,515 \text{ MHz}$	$-6,2 + 15(f_{\text{offset}}/\text{MHz} - 2,715) \text{ dBm}$	30 kHz
(note 3)	$3,515 \text{ MHz} \leq f_{\text{offset}} < 4,0 \text{ MHz}$	-18,2 dBm	30 kHz
$3,5 \text{ MHz} \leq \Delta f < 7,5 \text{ MHz}$	$4,0 \text{ MHz} \leq f_{\text{offset}} < 8,0 \text{ MHz}$	-5,2 dBm	1 MHz
$7,5 \text{ MHz} \leq \Delta f \leq \Delta f_{\text{max}}$	$8,0 \text{ MHz} \leq f_{\text{offset}} < f_{\text{offset}_{\text{max}}}$	$P_{\text{rated,c,TRP}} - 54,2 \text{ dB}$	1 MHz
NOTE 1: For a RIB supporting <i>non-contiguous spectrum</i> operation the <i>basic limit</i> within <i>sub-block gaps</i> within any <i>operating band</i> is calculated as a cumulative sum of contributions from adjacent sub-blocks on each side of the <i>sub-block gap</i> , where the contribution from the far-end <i>sub-block</i> shall be scaled according to the <i>measurement bandwidth</i> of the near-end <i>sub-block</i> . Exception is $\Delta f \geq 12,5 \text{ MHz}$ from both adjacent sub-blocks on each side of the <i>sub-block gap</i> , where the <i>basic limit</i> is $P_{\text{rated,c,TRP}} - 54,2 \text{ dB}$.			
NOTE 2: For a <i>multi-band RIB</i> with <i>Inter RF Bandwidth gap</i> $< 2 \times \Delta f_{\text{OBUe}}$ the <i>basic limit</i> within the <i>Inter RF Bandwidth gaps</i> is calculated as a cumulative sum of contributions from adjacent <i>sub-blocks</i> or <i>Base Station RF Bandwidth</i> on each side of the <i>Inter RF Bandwidth gap</i> , where the contribution from the far-end <i>sub-block</i> or <i>Base Station RF Bandwidth</i> shall be scaled according to the <i>measurement bandwidth</i> of the near-end <i>sub-block</i> or <i>Base Station RF Bandwidth</i> .			
NOTE 3: This frequency range ensures that the range of values of f_{offset} is continuous.			

Table 4.3.14.2-4: Spectrum emission mask, $45 \text{ dBm} \leq P_{\text{rated,c,TRP}} < 49 \text{ dBm}$ for UTRA bands $> 3 \text{ GHz}$

Frequency offset of measurement filter -3 dB point, Δf	Frequency offset of measurement filter centre frequency, f_{offset}	Basic limit (notes 1 and 2)	Measurement bandwidth
$2,5 \text{ MHz} \leq \Delta f < 2,7 \text{ MHz}$	$2,515 \text{ MHz} \leq f_{\text{offset}} < 2,715 \text{ MHz}$	-6 dBm	30 kHz
$2,7 \text{ MHz} \leq \Delta f < 3,5 \text{ MHz}$	$2,715 \text{ MHz} \leq f_{\text{offset}} < 3,515 \text{ MHz}$	$-6 + 15(f_{\text{offset}}/\text{MHz} - 2,715) \text{ dBm}$	30 kHz
(note 3)	$3,515 \text{ MHz} \leq f_{\text{offset}} < 4,0 \text{ MHz}$	-18 dBm	30 kHz
$3,5 \text{ MHz} \leq \Delta f < 7,5 \text{ MHz}$	$4,0 \text{ MHz} \leq f_{\text{offset}} < 8,0 \text{ MHz}$	-5 dBm	1 MHz
$7,5 \text{ MHz} \leq \Delta f \leq \Delta f_{\text{max}}$	$8,0 \text{ MHz} \leq f_{\text{offset}} < f_{\text{offset}_{\text{max}}}$	$P_{\text{rated,c,TRP}} - 54 \text{ dB}$	1 MHz
NOTE 1: For a RIB supporting <i>non-contiguous spectrum</i> operation the <i>basic limit</i> within <i>sub-block gaps</i> within any <i>operating band</i> is calculated as a cumulative sum of contributions from adjacent sub-blocks on each side of the <i>sub-block gap</i> , where the contribution from the far-end <i>sub-block</i> shall be scaled according to the <i>measurement bandwidth</i> of the near-end <i>sub-block</i> . Exception is $\Delta f \geq 12,5 \text{ MHz}$ from both adjacent sub-blocks on each side of the <i>sub-block gap</i> , where the <i>basic limit</i> is $P_{\text{rated,c,TRP}} - 54,2 \text{ dB}$.			
NOTE 2: For a <i>multi-band RIB</i> with <i>Inter RF Bandwidth gap</i> $< 2 \times \Delta f_{\text{OBUe}}$ the <i>basic limit</i> within the <i>Inter RF Bandwidth gaps</i> is calculated as a cumulative sum of contributions from adjacent <i>sub-blocks</i> or <i>Base Station RF Bandwidth</i> on each side of the <i>Inter RF Bandwidth gap</i> , where the contribution from the far-end <i>sub-block</i> or <i>Base Station RF Bandwidth</i> shall be scaled according to the <i>measurement bandwidth</i> of the near-end <i>sub-block</i> or <i>Base Station RF Bandwidth</i> .			
NOTE 3: This frequency range ensures that the range of values of f_{offset} is continuous.			

Table 4.3.14.2-5: Spectrum emission mask, $37 \text{ dBm} \leq P_{\text{rated,c,TRP}} < 45 \text{ dBm}$ for UTRA bands $\leq 3 \text{ GHz}$

Frequency offset of measurement filter -3 dB point, Δf	Frequency offset of measurement filter centre frequency, f_{offset}	Basic limit (notes 1 and 2)	Measurement bandwidth
$2,5 \text{ MHz} \leq \Delta f < 2,7 \text{ MHz}$	$2,515 \text{ MHz} \leq f_{\text{offset}} < 2,715 \text{ MHz}$	$P_{\text{rated,c,TRP}} - 51,2 \text{ dB}$	30 kHz
$2,7 \text{ MHz} \leq \Delta f < 3,5 \text{ MHz}$	$2,715 \text{ MHz} \leq f_{\text{offset}} < 3,515 \text{ MHz}$	$P_{\text{rated,c,TRP}} - 51,2 - 15(f_{\text{offset}}/\text{MHz} - 2,715) \text{ dB}$	30 kHz
(note 3)	$3,515 \text{ MHz} \leq f_{\text{offset}} < 4,0 \text{ MHz}$	$P_{\text{rated,c,TRP}} - 63,2 \text{ dB}$	30 kHz
$3,5 \text{ MHz} \leq \Delta f < 7,5 \text{ MHz}$	$4,0 \text{ MHz} \leq f_{\text{offset}} < 8,0 \text{ MHz}$	$P_{\text{rated,c,TRP}} - 50,2 \text{ dB}$	1 MHz
$7,5 \text{ MHz} \leq \Delta f \leq \Delta f_{\text{max}}$	$8,0 \text{ MHz} \leq f_{\text{offset}} < f_{\text{offset}_{\text{max}}}$	$P_{\text{rated,c,TRP}} - 54,2 \text{ dB}$	1 MHz
NOTE 1: For a RIB supporting <i>non-contiguous spectrum</i> operation the <i>basic limit</i> within <i>sub-block gaps</i> within any <i>operating band</i> is calculated as a cumulative sum of contributions from adjacent sub-blocks on each side of the <i>sub-block gap</i> , where the contribution from the far-end <i>sub-block</i> shall be scaled according to the <i>measurement bandwidth</i> of the near-end <i>sub-block</i> . Exception is $\Delta f \geq 12,5 \text{ MHz}$ from both adjacent sub-blocks on each side of the <i>sub-block gap</i> , where the <i>basic limit</i> is $P_{\text{rated,c,TRP}} - 54,2 \text{ dB}$.			
NOTE 2: For a <i>multi-band RIB</i> with <i>Inter RF Bandwidth gap</i> $< 2 \times \Delta f_{\text{OBUE}}$ the <i>basic limit</i> within the <i>Inter RF Bandwidth gaps</i> is calculated as a cumulative sum of contributions from adjacent <i>sub-blocks</i> or <i>Base Station RF Bandwidth</i> on each side of the <i>Inter RF Bandwidth gap</i> , where the contribution from the far-end <i>sub-block</i> or <i>Base Station RF Bandwidth</i> shall be scaled according to the <i>measurement bandwidth</i> of the near-end <i>sub-block</i> or <i>Base Station RF Bandwidth</i> .			
NOTE 3: This frequency range ensures that the range of values of f_{offset} is continuous.			

Table 4.3.14.2-6: Spectrum emission mask, $37 \text{ dBm} \leq P_{\text{rated,c,TRP}} < 45 \text{ dBm}$ for UTRA bands $> 3 \text{ GHz}$

Frequency offset of measurement filter -3 dB point, Δf	Frequency offset of measurement filter centre frequency, f_{offset}	Basic limit (notes 1 and 2)	Measurement bandwidth
$2,5 \text{ MHz} \leq \Delta f < 2,7 \text{ MHz}$	$2,515 \text{ MHz} \leq f_{\text{offset}} < 2,715 \text{ MHz}$	$P_{\text{rated,c,TRP}} - 51 \text{ dB}$	30 kHz
$2,7 \text{ MHz} \leq \Delta f < 3,5 \text{ MHz}$	$2,715 \text{ MHz} \leq f_{\text{offset}} < 3,515 \text{ MHz}$	$P_{\text{rated,c,TRP}} - 51 - 15(f_{\text{offset}}/\text{MHz} - 2,715) \text{ dB}$	30 kHz
(note 3)	$3,515 \text{ MHz} \leq f_{\text{offset}} < 4,0 \text{ MHz}$	$P_{\text{rated,c,TRP}} - 63 \text{ dB}$	30 kHz
$3,5 \text{ MHz} \leq \Delta f < 7,5 \text{ MHz}$	$4,0 \text{ MHz} \leq f_{\text{offset}} < 8,0 \text{ MHz}$	$P_{\text{rated,c,TRP}} - 50 \text{ dB}$	1 MHz
$7,5 \text{ MHz} \leq \Delta f \leq \Delta f_{\text{max}}$	$8,0 \text{ MHz} \leq f_{\text{offset}} < f_{\text{offset}_{\text{max}}}$	$P_{\text{rated,c,TRP}} - 54 \text{ dB}$	1 MHz
NOTE 1: For a RIB supporting <i>non-contiguous spectrum</i> operation the <i>basic limit</i> within <i>sub-block gaps</i> within any <i>operating band</i> is calculated as a cumulative sum of contributions from adjacent sub-blocks on each side of the <i>sub-block gap</i> , where the contribution from the far-end <i>sub-block</i> shall be scaled according to the <i>measurement bandwidth</i> of the near-end <i>sub-block</i> . Exception is $\Delta f \geq 12,5 \text{ MHz}$ from both adjacent sub-blocks on each side of the <i>sub-block gap</i> , where the <i>basic limit</i> is $P_{\text{rated,c,TRP}} - 54 \text{ dB}$.			
NOTE 2: For a <i>multi-band RIB</i> with <i>Inter RF Bandwidth gap</i> $< 2 \times \Delta f_{\text{OBUE}}$ the within the <i>Inter RF Bandwidth gaps</i> is calculated as a cumulative sum of contributions from adjacent <i>sub-blocks</i> or <i>Base Station RF Bandwidth</i> on each side of the <i>Inter RF Bandwidth gap</i> , where the contribution from the far-end <i>sub-block</i> or <i>Base Station RF Bandwidth</i> shall be scaled according to the <i>measurement bandwidth</i> of the near-end <i>sub-block</i> or <i>Base Station RF Bandwidth</i> .			
NOTE 3: This frequency range ensures that the range of values of f_{offset} is continuous.			

Table 4.3.14.2-7: Spectrum emission mask, $P_{\text{rated,c,TRP}} < 37 \text{ dBm}$ for UTRA bands $\leq 3 \text{ GHz}$

Frequency offset of measurement filter -3 dB point, Δf	Frequency offset of measurement filter centre frequency, f_{offset}	Basic limit (notes 1 and 2)	Measurement bandwidth
$2,5 \text{ MHz} \leq \Delta f < 2,7 \text{ MHz}$	$2,515 \text{ MHz} \leq f_{\text{offset}} < 2,715 \text{ MHz}$	-14,2 dBm	30 kHz
$2,7 \text{ MHz} \leq \Delta f < 3,5 \text{ MHz}$	$2,715 \text{ MHz} \leq f_{\text{offset}} < 3,515 \text{ MHz}$	-14,2 dBm -15($f_{\text{offset}}/\text{MHz}-2,715$) dB	30 kHz
(note 3)	$3,515 \text{ MHz} \leq f_{\text{offset}} < 4,0 \text{ MHz}$	-26,2 dBm	30 kHz
$3,5 \text{ MHz} \leq \Delta f < 7,5 \text{ MHz}$	$4,0 \text{ MHz} \leq f_{\text{offset}} < 8,0 \text{ MHz}$	-13,2 dBm	1 MHz
$7,5 \text{ MHz} \leq \Delta f \leq \Delta f_{\text{max}}$	$8,0 \text{ MHz} \leq f_{\text{offset}} < f_{\text{offset,max}}$	-17,2 dBm	1 MHz
NOTE 1: For a RIB supporting <i>non-contiguous spectrum</i> operation the <i>basic limit</i> within <i>sub-block gaps</i> within any <i>operating band</i> is calculated as a cumulative sum of contributions from adjacent sub-blocks on each side of the <i>sub-block gap</i> , where the contribution from the far-end <i>sub-block</i> shall be scaled according to the <i>measurement bandwidth</i> of the near-end <i>sub-block</i> . Exception is $\Delta f \geq 12,5 \text{ MHz}$ from both adjacent sub-blocks on each side of the <i>sub-block gap</i> , where the <i>basic limit</i> is 17,2 dBm/MHz .			
NOTE 2: For a <i>multi-band RIB</i> with <i>Inter RF Bandwidth gap</i> $< 2 \times \Delta f_{\text{OBUE}}$ the <i>basic limit</i> within the <i>Inter RF Bandwidth gaps</i> is calculated as a cumulative sum of contributions from adjacent <i>sub-blocks</i> or <i>Base Station RF Bandwidth</i> on each side of the <i>Inter RF Bandwidth gap</i> , where the contribution from the far-end <i>sub-block</i> or <i>Base Station RF Bandwidth</i> shall be scaled according to the <i>measurement bandwidth</i> of the near-end <i>sub-block</i> or <i>Base Station RF Bandwidth</i> .			
NOTE 3: This frequency range ensures that the range of values of f_{offset} is continuous.			

Table 4.3.14.2-8: Spectrum emission mask, $P_{\text{rated,c,TRP}} < 37 \text{ dBm}$ for UTRA bands $> 3 \text{ GHz}$

Frequency offset of measurement filter -3 dB point, Δf	Frequency offset of measurement filter centre frequency, f_{offset}	Basic limit (notes 1 and 2)	Measurement bandwidth
$2,5 \text{ MHz} \leq \Delta f < 2,7 \text{ MHz}$	$2,515 \text{ MHz} \leq f_{\text{offset}} < 2,715 \text{ MHz}$	-14 dBm	30 kHz
$2,7 \text{ MHz} \leq \Delta f < 3,5 \text{ MHz}$	$2,715 \text{ MHz} \leq f_{\text{offset}} < 3,515 \text{ MHz}$	-14 dBm -15($f_{\text{offset}}/\text{MHz}-2,715$)dB	30 kHz
(note 3)	$3,515 \text{ MHz} \leq f_{\text{offset}} < 4,0 \text{ MHz}$	-26 dBm	30 kHz
$3,5 \text{ MHz} \leq \Delta f < 7,5 \text{ MHz}$	$4,0 \text{ MHz} \leq f_{\text{offset}} < 8,0 \text{ MHz}$	-13 dBm	1 MHz
$7,5 \text{ MHz} \leq \Delta f \leq \Delta f_{\text{max}}$	$8,0 \text{ MHz} \leq f_{\text{offset}} < f_{\text{offset,max}}$	-17 dBm	1 MHz
NOTE 1: For a <i>RIB</i> supporting <i>non-contiguous spectrum</i> operation the <i>basic limit</i> within <i>sub-block gaps</i> within any <i>operating band</i> is calculated as a cumulative sum of contributions from adjacent sub-blocks on each side of the <i>sub-block gap</i> , where the contribution from the far-end <i>sub-block</i> shall be scaled according to the <i>measurement bandwidth</i> of the near-end <i>sub-block</i> . Exception is $\Delta f \geq 12,5 \text{ MHz}$ from both adjacent sub-blocks on each side of the <i>sub-block gap</i> , where the <i>basic limit</i> is -17 dBm/MHz.			
NOTE 2: For a <i>multi-band RIB</i> with <i>Inter RF Bandwidth gap</i> $< 2 \times \Delta f_{\text{OBUE}}$ the <i>basic limit</i> within the <i>Inter RF Bandwidth gaps</i> is calculated as a cumulative sum of contributions from adjacent <i>sub-blocks</i> or <i>Base Station RF Bandwidth</i> on each side of the <i>Inter RF Bandwidth gap</i> , where the contribution from the far-end <i>sub-block</i> or <i>Base Station RF Bandwidth</i> shall be scaled according to the <i>measurement bandwidth</i> of the near-end <i>sub-block</i> or <i>Base Station RF Bandwidth</i> .			
NOTE 3: This frequency range ensures that the range of values of f_{offset} is continuous.			

NOTE 1: For AAS BS operating in band XX, additional limits for protection of DTT are described in clause 6.7.4.5.1 of ETSI TS 137 145-2 [3]. This statement is provided for information and does not have any impact on the conformance requirements or essential radio test suites in the present document.

NOTE 2: For a AAS BS operating in band XXXII, additional limits are described in clause 6.7.4.5.1 of ETSI TS 137 145-2 [3]. This statement is provided for information and does not have any impact on the conformance requirements or essential radio test suites in the present document.

4.3.14.3 Conformance

The conformance tests for this requirement shall be as defined in clause 5.3.14 of the present document.

4.3.15 OTA Adjacent Channel Leakage power Ratio (OTA ACLR)

4.3.15.1 Definition and applicability

OTA Adjacent Channel Leakage power Ratio (ACLR) is the ratio of the filtered mean power centred on the assigned channel frequency to the filtered mean power centred on an adjacent channel frequency. Both powers are expressed as TRP.

The OTA ACLR is defined with a square filter of bandwidth equal to the *transmission bandwidth* configuration of the transmitted signal (BW_{Config}) centred on the assigned channel frequency and a filter centred on the adjacent channel frequency according to the tables below.

The Cumulative Adjacent Channel Leakage power Ratio (CACLR) in a *sub-block gap* or the *Inter RF Bandwidth gap* is the ratio of:

- the sum of the filtered mean power centred on the assigned channel frequencies for the two carriers adjacent to each side of the *sub-block gap* or the *Inter RF Bandwidth gap*; and
- the filtered mean power centred on a frequency channel adjacent to one of the respective *sub-block* edges or *Base Station RF Bandwidth edges*.

The requirement applies during the *transmitter ON period*.

With reference to ETSI TS 125 141 [7], the RRC pulse-shaping filter on the adjacent channel frequency is a root-raised cosine with roll-off $\alpha = 0,22$ in the frequency domain. The impulse response of the chip impulse filter $RC_0(t)$ is:

$$RC_0(t) = \frac{\sin\left(\pi\frac{t}{T_C}(1-\alpha)\right) + 4\alpha\frac{t}{T_C}\cos\left(\pi\frac{t}{T_C}(1+\alpha)\right)}{\pi\frac{t}{T_C}\left(1 - \left(4\alpha\frac{t}{T_C}\right)^2\right)}$$

Where the roll-off factor $\alpha = 0,22$ and the chip duration:

$$T_C = \frac{1}{\text{chiprate}}$$

4.3.15.2 Limits

4.3.15.2.1 General

The absolute limits in clause 4.3.15.2.2 or the ACLR/CACLR relative limits in clause 4.3.15.2.3, whichever is less stringent, shall apply.

4.3.15.2.2 Absolute limits

The filtered mean power centred on an adjacent channel frequency shall not exceed the absolute basic limit in table 4.3.15.2.2-1.

Table 4.3.15.2.2-1: BS type 1-O ACLR/CACLR absolute limit

BS class	OTA ACLR absolute limit For E-UTRA and NR carriers	OTA ACLR absolute limit for UTRA carriers
Wide Area BS	-6 dBm/MHz	-9 dBm/MHz
Medium Range BS	-16 dBm/MHz	-19 dBm/MHz
Local Area BS	-23 dBm/MHz	-26 dBm/MHz

4.3.15.2.3 Relative limits

4.3.15.2.3.1 OTA ACLR limits for MSR E-UTRA operation

For AAS BS supporting *MSR operation*, the OTA ACLR limits for E-UTRA carriers are specified below.

The limits are specified in tables 4.3.15.2.3.1-1 and 4.3.15.2.3.1-2, and applies outside the *Base Station RF Bandwidth* or *Maximum Radio Bandwidth*.

For an AAS BS operating in *non-contiguous spectrum*, the OTA ACLR also applies for the first adjacent channel inside any *sub-block gap* with a gap size $W_{\text{gap}} \geq 15$ MHz. The OTA ACLR limit for the second adjacent channel applies inside any *sub-block gap* with a gap size $W_{\text{gap}} \geq 20$ MHz. The CAACLR limit in clause 4.3.15.2.3.8 applies in *sub-block gaps* for the frequency ranges defined in tables 4.3.15.2.3.8-1 and 4.3.15.2.3.8-2.

For a *multi-band RIB*, the ACLR also applies for the first adjacent channel inside any *Inter RF Bandwidth gap* with a gap size $W_{\text{gap}} \geq 15$ MHz. The ACLR limit for the second adjacent channel applies inside any *Inter RF Bandwidth gap* with a gap size $W_{\text{gap}} \geq 20$ MHz. The OTA CAACLR limit in clause 4.3.15.2.3.8 applies in *Inter RF Bandwidth gaps* for the frequency ranges defined in tables 4.3.15.2.3.8-1 and 4.3.15.2.3.8-2.

For operation in paired spectrum, the OTA ACLR shall not be less than the limits specified in table 4.3.15.2.3.1-1.

Table 4.3.15.2.3.1-1: OTA ACLR in paired spectrum

Channel bandwidth of E-UTRA Lowest/Highest Carrier transmitted BW_{Channel} (MHz)	BS adjacent channel centre frequency offset below the lower or above the upper <i>Base Station RF Bandwidth edge</i>	Assumed adjacent channel carrier	Filter on the adjacent channel frequency and filter bandwidth	OTA ACLR limit for bands below 3 GHz	OTA ACLR limit for bands between 3 GHz and 4,2 GHz
1,4; 3,0; 5; 10; 15; 20	0,5 x BW_{Channel}	E-UTRA of same BW	Square (BW_{Config})	44 dB	43,8 dB
	1,5 x BW_{Channel}	E-UTRA of same BW	Square (BW_{Config})	44 dB	43,8 dB
	2,5 MHz	3,84 Mcps UTRA	RRC (3,84 Mcps)	44 dB	43,8 dB
	7,5 MHz	3,84 Mcps UTRA	RRC (3,84 Mcps)	44 dB	43,8 dB
NOTE: BW_{Channel} and BW_{Config} are the <i>channel bandwidth</i> and <i>transmission bandwidth</i> configuration of the E-UTRA Lowest/Highest Carrier transmitted on the assigned channel frequency.					

For operation in unpaired spectrum, the OTA ACLR shall not be less than the limits specified in table 4.3.15.2.3.1-2.

Table 4.3.15.2.3.1-2: OTA ACLR in unpaired spectrum with *synchronized operation*

Channel bandwidth of E-UTRA Lowest/ Highest Carrier transmitted BW_{Channel} (MHz)	BS adjacent channel centre frequency offset below the lower or above the upper Base Station RF Bandwidth edge	Assumed adjacent channel carrier	Filter on the adjacent channel frequency and filter bandwidth	OTA ACLR limit for bands below 3 GHz	OTA ACLR limit for bands between 3 GHz and 4,2 GHz
1,4; 3	0,5 x BW_{Channel}	E-UTRA of same BW	Square (BW_{Config})	44 dB	43,8 dB
	1,5 x BW_{Channel}	E-UTRA of same BW	Square (BW_{Config})	44 dB	43,8 dB
	0,8 MHz	1,28 Mcps UTRA	RRC (1,28 Mcps)	44 dB	43,8 dB
	2,4 MHz	1,28 Mcps UTRA	RRC (1,28 Mcps)	44 dB	43,8 dB
5; 10; 15; 20	0,5 x BW_{Channel}	E-UTRA of same BW	Square (BW_{Config})	44 dB	43,8 dB
	1,5 x BW_{Channel}	E-UTRA of same BW	Square (BW_{Config})	44 dB	43,8 dB
	0,8 MHz	1,28 Mcps UTRA	RRC (1,28 Mcps)	44 dB	43,8 dB
	2,4 MHz	1,28 Mcps UTRA	RRC (1,28 Mcps)	44 dB	43,8 dB
	2,5 MHz	3,84 Mcps UTRA	RRC (3,84 Mcps)	44 dB	43,8 dB
	7,5 MHz	3,84 Mcps UTRA	RRC (3,84 Mcps)	44 dB	43,8 dB
	5 MHz	7,68 Mcps UTRA	RRC (7,68 Mcps)	44 dB	43,8 dB
	15 MHz	7,68 Mcps UTRA	RRC (7,68 Mcps)	44 dB	43,8 dB
NOTE: BW_{Channel} and BW_{Config} are the <i>channel bandwidth</i> and <i>transmission bandwidth</i> configuration of the E-UTRA Lowest/Highest Carrier transmitted on the assigned channel frequency.					

For operation in non-contiguous paired spectrum, the OTA ACLR shall not be less than the limits specified in table 4.3.15.2.3.1-3.

Table 4.3.15.2.3.1-3: OTA ACLR in non-contiguous paired spectrum

Sub-block gap size (W_{gap}) where the limit applies	BS adjacent channel centre frequency offset below or above the sub-block edge (inside the gap)	Assumed adjacent channel carrier	Filter on the adjacent channel frequency and filter bandwidth	OTA ACLR limit for bands below 3 GHz	OTA ACLR limit for bands between 3 GHz and 4,2 GHz
$W_{\text{gap}} \geq 15$ MHz	2,5 MHz	3,84 Mcps UTRA	RRC (3,84 Mcps)	44 dB	43,8 dB
$W_{\text{gap}} \geq 20$ MHz	7,5 MHz	3,84 Mcps UTRA	RRC (3,84 Mcps)	44 dB	43,8 dB

For operation in non-contiguous unpaired spectrum, the OTA ACLR shall not be less than the limits specified in table 4.3.15.2.3.1-4.

Table 4.3.15.2.3.1-4: OTA ACLR in non-contiguous unpaired spectrum

Sub-block gap size (W_{gap}) where the limit applies	BS adjacent channel centre frequency offset below or above the sub-block edge (inside the gap)	Assumed adjacent channel carrier	Filter on the adjacent channel frequency and filter bandwidth	OTA ACLR limit for bands below 3 GHz	OTA ACLR limit for bands between 3 GHz and 4,2 GHz
$W_{\text{gap}} \geq 15$ MHz	2,5 MHz	5 MHz E-UTRA	Square (BW_{Config})	44 dB	43,8 dB
$W_{\text{gap}} \geq 20$ MHz	7,5 MHz	5 MHz E-UTRA	Square (BW_{Config})	44 dB	43,8 dB

4.3.15.2.3.2 OTA ACLR limits for MSR UTRA operation

For AAS BS supporting *MSR operation*, the OTA ACLR limits for E-UTRA carriers are specified below.

The limits are specified in tables 4.3.15.2.3.2-1 and 4.3.15.2.3.2-2, and applies outside the *Base Station RF Bandwidth* or *Maximum Radio Bandwidth*.

The OTA ACLR shall not be less than the limits specified in table 4.3.15.2.3.2-1.

Table 4.3.15.2.3.2-1: OTA ACLR

BS channel offset below the first or above the last carrier frequency used	OTA ACLR limit for bands below 3 GHz	OTA ACLR limit for bands between 3 GHz and 4,2 GHz
5 MHz	44 dB	43,8 dB
10 MHz	44 dB	43,8 dB

NOTE: In certain regions, the adjacent channel power (the RRC filtered mean power centred on an adjacent channel frequency) shall not exceed -7,2 dBm/3,84 MHz (for Band I, III, IX, XI and XXI) or +2,8 dBm/3,84 MHz (for Band VI, VIII and XIX) or as specified by the ACLR limit, whichever is the higher.

The OTA ACLR shall not be less than the limits specified in table 4.3.15.2.3.2-2.

Table 4.3.15.2.3.2-2: OTA ACLR in *non-contiguous spectrum* or multiple bands

Sub-block or Inter RF Bandwidth gap size (W_{gap}) where the limit applies	BS adjacent channel centre frequency offset below or above the sub-block edge or the Base Station RF Bandwidth edge (inside the gap)	Assumed adjacent channel carrier (informative)	Filter on the adjacent channel frequency and filter bandwidth	OTA ACLR limit for bands below 3 GHz	OTA ACLR limit for bands between 3 GHz and 4,2 GHz
$W_{\text{gap}} \geq 15$ MHz	2,5 MHz	3,84 Mcps UTRA	RRC (3,84 Mcps)	44 dB	43,8 dB
$W_{\text{gap}} \geq 20$ MHz	7,5 MHz	3,84 Mcps UTRA	RRC (3,84 Mcps)	44 dB	43,8 dB

For an AAS BS operating in *non-contiguous spectrum*, OTA ACLR limit also applies for the first adjacent channel, inside any *sub-block gap* with a gap size $W_{\text{gap}} \geq 15$ MHz. The OTA ACLR limit for the second adjacent channel applies inside any *sub-block gap* with a gap size $W_{\text{gap}} \geq 20$ MHz. The OTA ACLR limit in clause 4.3.15.2.3.6 applies in *sub-block gaps* for the frequency ranges defined in table 4.3.15.2.3.6-1.

For a multi-band capable AAS BS OTA ACLR limit also applies for the first adjacent channel, inside any *Inter RF Bandwidth gap* with a gap size $W_{\text{gap}} \geq 15$ MHz. The OTA ACLR limit for the second adjacent channel applies inside any *Inter RF Bandwidth gap* with a gap size $W_{\text{gap}} \geq 20$ MHz. The OTA ACLR limit in clause 4.3.15.2.3.6 applies in *Inter RF Bandwidth gaps* for the frequency ranges defined in table 4.3.15.2.3.6-1.

4.3.15.2.3.3 OTA ACLR limit in *non-contiguous spectrum* for MSR operation

The following limit applies for *sub-block* or *Inter RF Bandwidth gap* sizes listed in table 4.3.15.2.3.3-1:

- Inside a sub-block gap within an operating band for a BS operating in non-contiguous spectrum.
- Inside an Inter RF Bandwidth gap for a BS operating in multiple bands, where multiple bands are mapped on the same TAB connector.

The requirement applies to adjacent channels of E-UTRA or UTRA carriers allocated adjacent to each side of the *sub-block gap* or the *Inter RF Bandwidth gap*. The assumed filter for the adjacent channel frequency is defined in table 4.3.15.2.3.3-1 and the filters on the assigned channels are defined in table 4.3.15.2.3.3-2.

NOTE: If the RAT on the assigned channel frequencies is different, the filters used are also different.

The ACLR for E-UTRA and UTRA carriers located on either side of the *sub-block gap* or the *Inter RF Bandwidth gap* shall not be less than the limit specified in table 4.3.15.2.3.3-1.

Table 4.3.15.2.3.3-1: OTA CACLR in *non-contiguous spectrum* or multiple bands

Band Category	Sub-block or Inter RF Bandwidth gap size (W_{gap}) where the limit applies [MHz]	BS adjacent channel centre frequency offset below or above the sub-block edge or the Base Station RF Bandwidth edge (inside the gap)	Assumed adjacent channel carrier (informative)	Filter on the adjacent channel frequency and filter bandwidth	OTA CACLR limit for bands below 3 GHz	OTA CACLR limit for bands between 3 GHz and 4,2 GHz
BC1, BC2	$5 \leq W_{gap} < 15$ (note 3)	2,5 MHz	3,84 Mcps UTRA	RRC (3,84 Mcps)	44 dB	43,8 dB
BC1, BC2	$10 < W_{gap} < 20$ (note 3)	7,5 MHz	3,84 Mcps UTRA	RRC (3,84 Mcps)	44 dB	43,8 dB
BC3	$5 \leq W_{gap} < 15$ (note 3)	2,5 MHz	5 MHz E-UTRA	Square (BWConfig)	44 dB	43,8 dB
BC3	$10 < W_{gap} < 20$ (note 3)	7,5 MHz	5 MHz E-UTRA	Square (BWConfig)	44 dB	43,8 dB
BC1, BC2, BC3	$5 \leq W_{gap} < 45$ (note 4)	2,5 MHz	5 MHz NR (note 1)	Square (BWConfig)	44 dB	43,8 dB
BC1, BC2, BC3	$10 \leq W_{gap} < 50$ (note 4)	7,5 MHz	5 MHz NR (note 1)	Square (BWConfig)	44 dB	43,8 dB
BC1, BC2, BC3	$20 \leq W_{gap} < 30$ (note 3, 5)	10 MHz	20 MHz NR (note 1)	Square (BWConfig)	44 dB	43,8 dB
BC1, BC2, BC3	$20 \leq W_{gap} < 60$ (note 4)	10 MHz	20 MHz NR (note 1)	Square (BWConfig)	45 dB	43,8 dB
BC1, BC2, BC3	$40 \leq W_{gap} < 50$ (note 3, 5)	30 MHz	20 MHz NR (note 1)	Square (BWConfig)	44 dB	43,8 dB
BC1, BC2, BC3	$40 \leq W_{gap} < 80$ (note 4)	30 MHz	20 MHz NR (note 1)	Square (BWConfig)	44 dB	43,8 dB

NOTE 1: With SCS that provides largest *transmission bandwidth* configuration (BW_{Config}).

NOTE 2: Applicable in case the *channel bandwidth* of the carrier transmitted at the other edge of the gap is 5, 10, 15, 20 MHz.

NOTE 3: Applicable in case the *channel bandwidth* of the NR carrier transmitted at the other edge of the gap is 25, 30, 40, 50, 60, 70, 80, 90, 100 MHz.

NOTE 4: Applicable in case the *channel bandwidth* of the lowest/highest NR carrier transmitted is 25, 30, 40, 50, 60, 70, 80, 90, 100 MHz.

Table 4.3.15.2.3.3-2: Filter parameters for the assigned channel

RAT of the carrier adjacent to the sub-block or Inter RF Bandwidth gap	Filter on the assigned channel frequency and filter bandwidth
E-UTRA	E-UTRA of same BW
NR	NR of same BW with SCS that provides largest <i>transmission bandwidth</i> configuration (BW_{Config})
UTRA FDD	RRC (3,84 Mcps)

4.3.15.2.3.4 OTA ACLR limits for MSR NR operation

For AAS BS supporting *MSR operation*, the OTA ACLR limits for NR carriers are specified below.

The limits are specified in tables 4.3.15.2.3.4-1 and 4.3.15.2.3.4-2, and applies outside the *Base Station RF Bandwidth* or *Maximum Radio Bandwidth*.

For a RIB operating in *non-contiguous spectrum*, the OTA ACLR limit applies inside *sub-block gaps* for the frequency ranges defined in table 4.3.15.2.3.4-2, while the CACLR limit applies inside *sub-block gaps* for the frequency ranges defined in table 4.3.15.2.3.3-1.

For a *multi-band RIB*, the OTA ACLR limit applies inside *Inter RF Bandwidth gaps* for the frequency ranges defined in table 4.3.15.2.5-2a, while the OTA CACLR limit applies inside *Inter RF Bandwidth gaps* for the frequency ranges defined in table 4.3.15.2.3.3-1.

For operation in paired and unpaired spectrum, the OTA ACLR shall not be less than the limits limit specified in table 4.3.15.2.3.4-1.

Table 4.3.15.2.3.4-1: NR ACLR limit

BS channel bandwidth of lowest/highest NR carrier transmitted BW_{Channel} [MHz]	BS adjacent channel centre frequency offset below the lowest- or above the highest carrier centre frequency transmitted	Assumed adjacent channel carrier (informative)	Filter on the adjacent channel frequency and filter bandwidth	OTA ACLR limit (0 GHz - 3 GHz)	OTA ACLR limit (3 GHz - 4,2 GHz)
5; 10; 15; 20; 25; 30; 40; 50; 60; 70; 80; 90;100	BW _{Channel}	NR of same BW (note 2)	Square (BW _{Config})	44 dB	43,8 dB
	2 x BW _{Channel}	NR of same BW (note 2)	Square (BW _{Config})	44 dB	43,8 dB
	BW _{Channel} /2 + 2,5 MHz	5 MHz E-UTRA	Square (4,5 MHz)	44 dB (note 3)	43,8 dB (note 3)
	BW _{Channel} /2 + 7,5 MHz	5 MHz E-UTRA	Square (4,5 MHz)	44 dB (note 3)	43,8 dB (note 3)
NOTE 1: BW _{Channel} and BW _{Config} are the <i>BS channel bandwidth</i> and <i>transmission bandwidth</i> configuration of the lowest/highest NR carrier transmitted on the assigned channel frequency.					
NOTE 2: With SCS that provides largest <i>transmission bandwidth</i> configuration (BW _{Config}).					
NOTE 3: The limits are applicable when the band is also defined for E-UTRA or UTRA.					

For operation in *non-contiguous spectrum* or multiple bands, the OTA ACLR shall not be less than the limits specified in table 4.3.15.2.3.4-2.

Table 4.3.15.2.3.4-2: NR ACLR limit in *non-contiguous spectrum* or multiple bands

BS channel bandwidth of NR carrier transmitted adjacent to sub-block gap or inter RF Bandwidth gap BW_{Channel} [MHz]	Sub-block or Inter RF Bandwidth gap size (W_{gap}) where the limit applies [MHz]	BS adjacent channel centre frequency offset below or above the sub-block or Base Station RF Bandwidth edge (inside the gap)	Assumed adjacent channel carrier	Filter on the adjacent channel frequency and filter bandwidth	OTA ACLR limit (0 GHz - 3 GHz)	OTA ACLR limit (3 GHz - 4,2 GHz)
5; 10; 15; 20	W _{gap} ≥ 15 (note 3) W _{gap} ≥ 45 (note 4)	2,5 MHz	5 MHz NR (note 2)	Square (BW _{Config})	44 dB	43,8 dB
	W _{gap} ≥ 20 (note 3) W _{gap} ≥ 50 (note 4)	7,5 MHz	5 MHz NR (note 2)	Square (BW _{Config})	44 dB	43,8 dB
25; 30; 40; 50; 60; 70; 80; 90; 100	W _{gap} ≥ 60 (note 4) W _{gap} ≥ 30 (note 3)	10 MHz	20 MHz NR (note 2)	Square (BW _{Config})	44 dB	43,8 dB
	W _{gap} ≥ 80 (note 4) W _{gap} ≥ 50 (note 3)	30 MHz	20 MHz NR (note 2)	Square (BW _{Config})	44 dB	43,8 dB
NOTE 1: BW _{Config} is the <i>transmission bandwidth</i> configuration of the assumed adjacent channel carrier.						
NOTE 2: With SCS that provides largest <i>transmission bandwidth</i> configuration (BW _{Config}).						
NOTE 3: Applicable in case the <i>BS channel bandwidth</i> of the carrier transmitted at the other edge of the gap is 5, 10, 15, 20 MHz.						
NOTE 4: Applicable in case the <i>BS channel bandwidth</i> of the NR carrier transmitted at the other edge of the gap is 25, 30, 40, 50, 60, 70, 80, 90, 100 MHz.						

4.3.15.2.3.5 OTA ACLR limits for UTRA only operation

This requirement applies for RIBs supporting only *single RAT UTRA operation*.

OTA ACLR shall not be less than the limit specified in tables 4.3.15.2.3.5-1 and 4.3.15.2.3.5-2.

Table 4.3.15.2.3.5-1: OTA ACLR

BS channel offset below the first or above the last carrier frequency used	OTA ACLR limit for bands below 3 GHz	OTA ACLR limit for bands between 3 GHz and 4,2 GHz
5 MHz	44 dB	43,8 dB
10 MHz	44 dB	43,8 dB
NOTE : In certain regions, the adjacent channel power (the RRC filtered mean power centred on an adjacent channel frequency) shall not exceed -7,2 dBm/3,84 MHz (for Band I, III, IX, XI and XXI) or +2,8 dBm/3,84 MHz (for Band VI, VIII and XIX) or as specified by the ACLR limit, whichever is the higher.		

Table 4.3.15.2.3.5-2: OTA ACLR in *non-contiguous spectrum* or multiple bands

Sub-block or Inter RF Bandwidth gap size (W_{gap}) where the limit applies	BS adjacent channel centre frequency offset below or above the sub-block edge or the Base Station RF Bandwidth edge (inside the gap)	Assumed adjacent channel carrier (informative)	Filter on the adjacent channel frequency and filter bandwidth	OTA ACLR limit for bands below 3 GHz	OTA ACLR limit for bands between 3 GHz and 4,2 GHz
$W_{\text{gap}} \geq 15$ MHz	2,5 MHz	3,84 Mcps UTRA	RRC (3,84 Mcps)	44 dB	43,8 dB
$W_{\text{gap}} \geq 20$ MHz	7,5 MHz	3,84 Mcps UTRA	RRC (3,84 Mcps)	44 dB	43,8 dB

4.3.15.2.3.6 OTA CACLR limits in *non-contiguous spectrum* or multiple bands for UTRA only operation

The following limit applies for RIB supporting only *single RAT UTRA operation* in *non-contiguous spectrum* or multiple bands.

The following limit applies for the gap sizes listed in table 4.3.15.2.3.6-1:

- Inside a *sub-block gap* within an *operating band* for an AAS BS operating in *non-contiguous spectrum*;
- Inside an *Inter RF Bandwidth gap* for a multi-band capable AAS BS.

The assumed filter for the adjacent channel frequency is defined in table 4.3.15.2.3.6-1 and the filters on the assigned channels are defined in table 4.3.15.2.3.6-2.

The CACLR for UTRA carriers located on either side of the *sub-block gap* or *Inter RF Bandwidth gap* shall not be less than the value specified in table 4.3.15.2.3.6-1.

Table 4.3.15.2.3.6-1: OTA CACLR in *non-contiguous spectrum* or multiple bands

Sub-block or Inter RF Bandwidth gap size (W_{gap}) where the limit applies	BS adjacent channel centre frequency offset below or above the sub-block edge or the Base Station RF Bandwidth edge (inside the gap)	Assumed adjacent channel carrier (informative)	Filter on the adjacent channel frequency and filter bandwidth	OTA CACLR limit for bands below 3 GHz	OTA CACLR limit for bands between 3 GHz and 4,2 GHz
$5 \text{ MHz} \leq W_{\text{gap}} < 15 \text{ MHz}$	2,5 MHz	3,84 Mcps UTRA	RRC (3,84 Mcps)	44 dB	43,8 dB
$10 \text{ MHz} < W_{\text{gap}} < 20 \text{ MHz}$	7,5 MHz	3,84 Mcps UTRA	RRC (3,84 Mcps)	44 dB	43,8 dB

Table 4.3.15.2.3.6-2: Filter parameters for the assigned channel

RAT of the carrier adjacent to the sub-block or Inter RF Bandwidth gap	Filter on the assigned channel frequency and filter bandwidth
UTRA FDD	RRC (3,84 Mcps)

4.3.15.2.3.7 OTA ACLR limits for E-UTRA only operation

This requirement applies for RIBs supporting only *single RAT E-UTRA operation*.

For operation in paired spectrum, the OTA ACLR shall not be less than the limits specified in table 4.3.15.2.3.7-1.

Table 4.3.15.2.3.7-1: OTA ACLR in paired spectrum

Channel bandwidth of E-UTRA lowest/highest carrier transmitted BW_{Channel} (MHz)	BS adjacent channel centre frequency offset below the lowest- or above the highest carrier centre frequency transmitted	Assumed adjacent channel carrier (informative)	Filter on the adjacent channel frequency and filter bandwidth	OTA ACLR limit for bands below 3 GHz	OTA ACLR limit for bands between 3 GHz and 4,2 GHz
1,4; 3; 5; 10; 15; 20	BW_{Channel}	E-UTRA of same BW	Square (BW_{Config})	44 dB	43,8 dB
	$2 \times BW_{\text{Channel}}$	E-UTRA of same BW	Square (BW_{Config})	44 dB	43,8 dB
	$BW_{\text{Channel}}/2 + 2,5 \text{ MHz}$	3,84 Mcps UTRA	RRC (3,84 Mcps)	44 dB	43,8 dB
	$BW_{\text{Channel}}/2 + 7,5 \text{ MHz}$	3,84 Mcps UTRA	RRC (3,84 Mcps)	44 dB	43,8 dB
NOTE: BW_{Channel} and BW_{Config} are the <i>channel bandwidth</i> and <i>transmission bandwidth</i> configuration of the E-UTRA lowest/highest/ carrier transmitted on the assigned channel frequency.					

For operation in unpaired spectrum, the measurement result shall not be less than the OTA ACLR limit specified in table 4.3.15.2.3.7-2.

Table 4.3.15.2.3.7-2: OTA ACLR in unpaired spectrum with *synchronized operation*

Channel bandwidth of E-UTRA lowest/highest carrier transmitted BW_{Channel} (MHz)	BS adjacent channel centre frequency offset below the lowest- or above the highest carrier centre frequency transmitted	Assumed adjacent channel carrier (informative)	Filter on the adjacent channel frequency and filter bandwidth	OTA ACLR limit for bands below 3 GHz	OTA ACLR limit for bands between 3 GHz and 4,2 GHz
1,4; 3	BW_{Channel}	E-UTRA of same BW	Square (BW_{Config})	44 dB	43,8 dB
	$2 \times BW_{\text{Channel}}$	E-UTRA of same BW	Square (BW_{Config})	44 dB	43,8 dB
	$BW_{\text{Channel}}/2 + 0,8 \text{ MHz}$	1,28 Mcps UTRA	RRC (1,28 Mcps)	44 dB	43,8 dB
	$BW_{\text{Channel}}/2 + 2,4 \text{ MHz}$	1,28 Mcps UTRA	RRC (1,28 Mcps)	44 dB	43,8 dB
5; 10; 15; 20	BW_{Channel}	E-UTRA of same BW	Square (BW_{Config})	44 dB	43,8 dB
	$2 \times BW_{\text{Channel}}$	E-UTRA of same BW	Square (BW_{Config})	44 dB	43,8 dB
	$BW_{\text{Channel}}/2 + 0,8 \text{ MHz}$	1,28 Mcps UTRA	RRC (1,28 Mcps)	44 dB	43,8 dB
	$BW_{\text{Channel}}/2 + 2,4 \text{ MHz}$	1,28 Mcps UTRA	RRC (1,28 Mcps)	44 dB	43,8 dB
	$BW_{\text{Channel}}/2 + 2,5 \text{ MHz}$	3,84 Mcps UTRA	RRC (3,84 Mcps)	44 dB	43,8 dB
	$BW_{\text{Channel}}/2 + 7,5 \text{ MHz}$	3,84 Mcps UTRA	RRC (3,84 Mcps)	44 dB	43,8 dB
	$BW_{\text{Channel}}/2 + 15 \text{ MHz}$	7,68 Mcps UTRA	RRC (7,68 Mcps)	44 dB	43,8 dB
NOTE: BW_{Channel} and BW_{Config} are the <i>channel bandwidth</i> and <i>transmission bandwidth</i> configuration of the E-UTRA lowest/highest/ carrier transmitted on the assigned channel frequency.					

For operation in non-contiguous paired spectrum or multiple bands, the measurement result shall not be less than the OTA ACLR limit specified in table 4.3.15.2.3.7-3.

Table 4.3.15.2.3.7-3: OTA ACLR in non-contiguous paired spectrum or multiple bands

Sub-block or Inter RF Bandwidth gap size (W_{gap}) where the limit applies	BS adjacent channel centre frequency offset below or above the sub-block edge or the Base Station RF Bandwidth edge (inside the gap)	Assumed adjacent channel carrier (informative)	Filter on the adjacent channel frequency and filter bandwidth	OTA ACLR limit for bands below 3 GHz	OTA ACLR limit for bands between 3 GHz and 4,2 GHz
$W_{\text{gap}} \geq 15$ MHz	2,5 MHz	3,84 Mcps UTRA	RRC (3,84 Mcps)	44 dB	43,8 dB
$W_{\text{gap}} \geq 20$ MHz	7,5 MHz	3,84 Mcps UTRA	RRC (3,84 Mcps)	44 dB	43,8 dB

For operation in non-contiguous unpaired spectrum or multiple bands, the measurement result shall not be less than the OTA ACLR limit specified in table 4.3.15.2.3.7-4.

Table 4.3.15.2.3.7-4: OTA ACLR in non-contiguous unpaired spectrum or multiple bands

Sub-block or Inter RF Bandwidth gap size (W_{gap}) where the limit applies	BS adjacent channel centre frequency offset below or above the sub-block edge or the Base Station RF Bandwidth edge (inside the gap)	Assumed adjacent channel carrier (informative)	Filter on the adjacent channel frequency and filter bandwidth	OTA ACLR limit for bands below 3 GHz	OTA ACLR limit for bands between 3 GHz and 4,2 GHz
$W_{\text{gap}} \geq 15$ MHz	2,5 MHz	5 MHz E-UTRA	Square (BW_{Config})	44 dB	43,8 dB
$W_{\text{gap}} \geq 20$ MHz	7,5 MHz	5 MHz E-UTRA	Square (BW_{Config})	44 dB	43,8 dB

4.3.15.2.3.8 OTA CA CLR limit in *non-contiguous spectrum* for E-UTRA only operation

This requirement applies for RIBs supporting only *single RAT E-UTRA operation*.

The following limit applies for the *sub-block* or *Inter RF Bandwidth gap* sizes listed in table 4.3.15.2.3.8-1:

- Inside a *sub-block gap* within an *operating band* for an AAS BS operating in *non-contiguous spectrum*.
- Inside an *Inter RF Bandwidth gap* for a multi-band capable AAS BS.

The assumed filter for the adjacent channel frequency is defined in tables 4.3.15.2.3.8-1 and 4.3.15.2.3.8-2. Filters on the assigned channels are defined in table 4.3.15.2.3.8-3.

For operation in *non-contiguous spectrum* or multiple bands, the CA CLR for E-UTRA carriers located on either side of the *sub-block gap* or *Inter RF Bandwidth gap* shall not be less than the value specified in tables 4.3.15.2.3.8-1 and 4.3.15.2.3.8-2.

Table 4.3.15.2.3.8-1: OTA CA CLR in non-contiguous paired spectrum or multiple bands

Sub-block or Inter RF Bandwidth gap size (W_{gap}) where the limit applies	BS adjacent channel centre frequency offset below or above the sub-block edge or the Base Station RF Bandwidth edge (inside the gap)	Assumed adjacent channel carrier (informative)	Filter on the adjacent channel frequency and filter bandwidth	OTA CA CLR limit for bands below 3 GHz	OTA CA CLR limit for bands between 3 GHz and 4,2 GHz
$5 \text{ MHz} \leq W_{\text{gap}} < 15$ MHz	2,5 MHz	3,84 Mcps UTRA	RRC (3,84 Mcps)	44 dB	43,8 dB
$10 \text{ MHz} < W_{\text{gap}} < 20$ MHz	7,5 MHz	3,84 Mcps UTRA	RRC (3,84 Mcps)	44 dB	43,8 dB

Table 4.3.15.2.3.8-2: OTA CACLR in non-contiguous unpaired spectrum or multiple bands

Sub-block or Inter RF Bandwidth gap size (W_{gap}) where the limit applies	BS adjacent channel centre frequency offset below or above the sub-block edge or the Base Station RF Bandwidth edge (inside the gap)	Assumed adjacent channel carrier (informative)	Filter on the adjacent channel frequency and filter bandwidth	OTA CACLR limit for bands below 3 GHz	OTA CACLR limit for bands between 3 GHz and 4,2 GHz
$5 \text{ MHz} \leq W_{\text{gap}} < 15 \text{ MHz}$	2,5 MHz	5 MHz E-UTRA carrier	Square (BW_{Config})	44 dB	43,8 dB
$10 \text{ MHz} < W_{\text{gap}} < 20 \text{ MHz}$	7,5 MHz	5 MHz E-UTRA carrier	Square (BW_{Config})	44 dB	43,8 dB

Table 4.3.15.2.3.8-3: Filter parameters for the assigned channel

RAT of the carrier adjacent to the sub-block or Inter RF Bandwidth gap	Filter on the assigned channel frequency and filter bandwidth
E-UTRA	E-UTRA of same BW

4.3.15.3 Conformance

The conformance tests for this requirement shall be as defined in clause 5.3.15 of the present document.

4.3.16 OTA transmitter spurious emissions

4.3.16.1 Definition and applicability

The OTA spurious emissions limits are specified as TRP per RIB, except limits in table 4.3.16.2.4-2.

The OTA transmitter spurious emission limits apply from 30 MHz to 12,75 GHz or the 5th harmonic limit of the *downlink operating band*, excluding the following RAT-specific frequency ranges:

- for RIB supporting *MSR operation*, from Δf_{OBUE} below the lowest frequency of the *downlink operating band* up to Δf_{OBUE} above the highest frequency of the *downlink operating band*, where Δf_{OBUE} is defined in table 4.3.13.1-1.
- for RIB supporting only *single RAT UTRA operation*, from 12,5 MHz below the *lowest carrier* frequency used up to 12,5 MHz above the *highest carrier* frequency used.
- for RIB supporting only *single RAT E-UTRA operation*, from Δf_{OBUE} below the lowest frequency of the *downlink operating band* up to Δf_{OBUE} above the highest frequency of the *downlink operating band*, where Δf_{OBUE} is defined in table 4.3.13.1-1.

NOTE: For bands 7,22, 38, 41, 42, 43, 69, 77 and 78 the upper frequency limit is higher than 12,75 GHz in order to comply with the 5th harmonic limit of the *downlink operating band*, as specified in Recommendation ITU-R SM.329-12 [i.4].

In some exceptional cases, requirements apply also closer than 10 MHz from the *downlink operating band*; these cases are highlighted in the requirement tables in respective referenced UTRA, E-UTRA, NR or MSR specifications. For *operating bands* supported by *multi-band RIB* each supported band including the Δf_{OBUE} around the band are excluded from the spurious emissions requirements.

The limits apply for both *single band RIBs* and *multi-band RIBs* (except for frequencies at which exclusion bands or other multi-band provisions apply) and for all transmission modes foreseen by the manufacturer's specification. All limits are expressed as mean power.

4.3.16.2 Limits

4.3.16.2.1 General spurious emissions limits

For AAS BS operating in single RAT E-UTRA configuration or AAS BS operating in MSR configuration the limits are specified in table 4.3.16.2.1-1.

For AAS BS operating in single RAT UTRA configuration the limits are specified in tables 4.3.16.2.1-2 and 4.3.16.2.1-3.

Table 4.3.16.2.1-1: AAS BS OTA Spurious emissions limits

Frequency range	Limit	Measurement Bandwidth	Notes
30 MHz ↔ 1 GHz	-36 dBm	100 kHz	Note 1
1 GHz ↔ 12,75 GHz	-30 dBm	1 MHz	Note 2
12,75 GHz ↔ 5 th harmonic of the upper frequency edge of the DL <i>operating band</i> in GHz	-36 dBm	1 MHz	Notes 2 and 3

NOTE 1: Bandwidth as in Recommendation ITU-R SM.329-12 [i.4], section 4.1.
 NOTE 2: Bandwidth as in Recommendation ITU-R SM.329-12 [i.4], section 4.1. Upper frequency as in Recommendation ITU-R SM.329-12 [i.4], section 2.5 table 1.
 NOTE 3: This spurious frequency range applies only for *operating bands* for which the 5th harmonic of the upper frequency edge of the DL *operating band* is reaching beyond 12,75 GHz.

Table 4.3.16.2.1-2: OTA AAS BS Mandatory spurious emissions limits, for UTRA only operation in bands I, III, VII, XXII, XXXII

Band	Limit	Measurement Bandwidth	Notes
30 MHz ↔ 1 GHz	-36 dBm	100 kHz	Note 1
1 GHz ↔ $F_{low} - 10$ MHz	-30 dBm	1 MHz	Note 1
$F_{low} - 10$ MHz ↔ $F_{high} + 10$ MHz	-15 dBm	1 MHz	Note 2
$F_{high} + 10$ MHz ↔ 12,75 GHz	-30 dBm	1 MHz	Note 3
12,75 GHz - 5 th harmonic of the upper frequency edge of the DL <i>operating band</i> in GHz	-30 dBm	1 MHz	Notes 3 and 4

NOTE 1: Bandwidth as in Recommendation ITU-R SM.329-12 [i.4], section 4.1.
 NOTE 2: Limit based on Recommendation ITU-R SM.329-12 [i.4], section 4.3 and annex 7.
 NOTE 3: Bandwidth as in Recommendation ITU-R SM.329-12 [i.4], section 4.1. Upper frequency as in Recommendation ITU-R SM.329-12 [i.4], section 2.5 table 1.
 NOTE 4: Applies only for Band XXII.

Table 4.3.16.2.1-3: BS Mandatory spurious emissions limits, for UTRA only operation in bands VIII and XX

Band	Limit	Measurement Bandwidth	Notes
30 MHz ↔ $F_{low} - 10$ MHz	-36 dBm	100 kHz	Note 1
$F_{low} - 10$ MHz ↔ $F_{high} + 10$ MHz	-16 dBm	100 kHz	Note 2
$F_{high} + 10$ MHz ↔ 1 GHz	-36 dBm	100 kHz	Note 1
1 GHz ↔ 12,75 GHz	-30 dBm	1 MHz	Note 3

NOTE 1: Bandwidth as in Recommendation ITU-R SM.329-12 [i.4], section 4.1.
 NOTE 2: Limit based on Recommendation ITU-R SM.329-12 [i.4], section 4.3 and annex 7.
 NOTE 3: Bandwidth as in Recommendation ITU-R SM.329-12 [i.4], section 4.1. Upper frequency as in Recommendation ITU-R SM.329-12 [i.4], section 2.5 table 1.

4.3.16.2.2 Limits for protection of the *BS receiver*

This requirement shall be applied for FDD operation in order to prevent the receivers of own or a different BS of the same band being desensitized by emissions from a *OTA AAS BS*.

The requirement is a co-location requirement as defined in clause 4.15, in ETSI TS 137 145-2 [3], the power levels are specified at the CLTA output(s).

The total power from both polarizations of the CLTA connector output(s) of any spurious emission shall not exceed the limits in tables 4.3.16.2.2-1 and 4.3.16.2.2-2.

For AAS BS supporting *MSR operation* the limits are specified in table 4.3.16.2.2-1.

Table 4.3.16.2.2-1: Spurious emissions *basic limits* for protection of the *BS receiver*

BS class	Band Category	Frequency range	MSR limit		Measurement bandwidth
			$f \leq 3$ GHz	3 GHz $< f \leq 4,2$ GHz	
Wide Area BS	BC1	$F_{UL_low} - F_{UL_high}$	-113,9 dBm	-113,7 dBm	100 kHz
Wide Area BS	BC2	$F_{UL_low} - F_{UL_high}$	-115,9 dBm	-115,7 dBm	100 kHz
Medium Range BS	BC1, BC2	$F_{UL_low} - F_{UL_high}$	-108,9 dBm	-108,7 dBm	100 kHz
Local Area BS	BC1, BC2	$F_{UL_low} - F_{UL_high}$	-105,9 dBm	-105,7 dBm	100 kHz

NOTE: For Band 28 BS, this requirement shall only apply in the uplink frequency range where the *BS receiver* is allowed to operate according to table 1-1.

For AAS BS supporting single RAT UTRA or E-UTRA operation the limits are specified in table 4.3.16.2.2-2:

Table 4.3.16.2.2-2: Spurious emissions *basic limits* for protection of the *BS receiver* for single RAT operation

BS class	Frequency range	UTRA limit	E-UTRA limit		Measurement bandwidth
		$f \leq 3$ GHz	$f \leq 3$ GHz	3 GHz $< f \leq 4,2$ GHz	
Wide Area BS	$F_{UL_low} - F_{UL_high}$	-116,9 dBm	-113,9 dBm	-113,7 dBm	100 kHz
Medium Range BS	$F_{UL_low} - F_{UL_high}$	-106,9 dBm	-108,9 dBm	-108,7 dBm	100 kHz
Local Area BS	$F_{UL_low} - F_{UL_high}$	-102,9 dBm	-105,9 dBm	-105,7 dBm	100 kHz

NOTE: For Band 28 BS, this requirement shall only apply in the uplink frequency range where the *BS receiver* is allowed to operate according to table 1-1.

4.3.16.2.3 Limits for co-existence with other systems

These requirements shall be applied for the protection of system operating in frequency ranges other than the *BS downlink operating band*.

The TRP of any spurious emission shall not exceed the limits in table 4.3.16.2.3-1 for an AAS BS where requirements for co-existence with the system listed in the first column apply. For a *multi-band RIB*, the exclusions and conditions in the notes column of table 4.3.16.2.3-1 apply for each supported *operating band*.

Table 4.3.16.2.3-1: OTA Spurious emissions limits for co-existence with systems operating in other frequency bands

System type to co-exist with	Frequency range for co-existence requirement	Limit for MSR and E-UTRA	Limit for UTRA	Measurement Bandwidth	Note
GSM900	921 - 960 MHz	-45,4 dBm	-48,4 dBm	100 kHz	This requirement shall not apply to BS operating in band 8
	876 - 915 MHz	-49,4 dBm	-52,4 dBm	100 kHz	For the frequency range 880 MHz - 915 MHz, this requirement shall not apply to BS operating in band 8 or VIII, since it is already covered by the requirement in clause 4.3.16.2.2

System type to co-exist with	Frequency range for co-existence requirement	Limit for MSR and E-UTRA	Limit for UTRA	Measurement Bandwidth	Note
DCS1800	1 805 - 1 880 MHz	-35,4 dBm	-38,4 dBm	100 kHz	This requirement shall not apply to BS operating in band 3
	1 710 - 1 785 MHz	-49,4 dBm	-52,4 dBm	100 kHz	This requirement shall not apply to BS operating in band 3, since it is already covered by the requirement in clause 4.3.16.2.2
UTRA FDD Band I or E-UTRA Band 1 or NR Band n1	2 110 - 2 170 MHz	-40,4 dBm	-43,4 dBm	1 MHz	This requirement shall not apply to BS operating in band 1 or 65
	1 920 - 1 980 MHz	-37,4 dBm	-40,4 dBm	1 MHz	This requirement shall not apply to BS operating in band 1 or 65, since it is already covered by the requirement in clause 4.3.16.2.2
UTRA FDD Band III or E-UTRA Band 3 or NR Band n3	1 805 - 1 880 MHz	-40,4 dBm	-43,4 dBm	1 MHz	This requirement shall not apply to BS operating in band 3
	1 710 - 1 785 MHz	-37,4 dBm	-40,4 dBm	1 MHz	This requirement shall not apply to BS operating in band 3, since it is already covered by the requirement in clause 4.3.16.2.2 For BS operating in band 9, it shall apply for 1 710 MHz to 1 749,9 MHz and 1 784,9 MHz to 1 785 MHz, while the rest is covered in clause 4.3.16.2.2
UTRA FDD Band VII or E-UTRA Band 7 or NR Band n7	2 620 - 2 690 MHz	-40,4 dBm	-43,4 dBm	1 MHz	This requirement shall not apply to BS operating in band 7
	2 500 - 2 570 MHz	-37,4 dBm	-40,4 dBm	1 MHz	This requirement shall not apply to BS operating in band 7, since it is already covered by the requirement in clause 4.3.16.2.2
UTRA FDD Band VIII or E-UTRA Band 8 or NR Band n8	925 - 960 MHz	-40,4 dBm	-43,4 dBm	1 MHz	This requirement shall not apply to BS operating in band 8
	880 - 915 MHz	-37,4 dBm	-40,4 dBm	1 MHz	This requirement shall not apply to BS operating in band 8, since it is already covered by the requirement in clause 4.3.16.2.2
UTRA FDD Band XX or E-UTRA Band 20 or NR Band n20	791 - 821 MHz	-40,4 dBm	-43,4 dBm	1 MHz	This requirement shall not apply to BS operating in band 20 or 28
	832 - 862 MHz	-37,4 dBm	-40,4 dBm	1 MHz	This requirement shall not apply to BS operating in band 20, since it is already covered by the requirement in clause 4.3.16.2.2
UTRA FDD Band XXII or E-UTRA Band 22	3 510 - 3 590 MHz	-40,0 dBm	-43,0 dBm	1 MHz	This requirement shall not apply to BS operating in band 22, 42, 77 or 78
	3 410 - 3 490 MHz	-37,0 dBm	-40,0 dBm	1 MHz	This requirement shall not apply to BS operating in band 22, since it is already covered by the requirement in clause 4.3.16.2.2. This requirement shall not apply to band 42, 77 or 78
E-UTRA Band 28 or NR Band n28	758 - 803 MHz	-40,4 dBm	-40,4 dBm	1 MHz	This requirement shall not apply to BS operating in band 20/n20, 28/n28 or 67
	703 - 748 MHz	-37,4 dBm	-43,4 dBm	1 MHz	This requirement shall not apply to BS operating in band 28, since it is already covered by the requirement in clause 4.3.16.2.2. For BS operating in Band 67, it shall apply for 703 - 736 MHz. For AAS BS operating in band 68, it shall apply for 728 MHz to 733 MHz

System type to co-exist with	Frequency range for co-existence requirement	Limit for MSR and E-UTRA	Limit for UTRA	Measurement Bandwidth	Note
E-UTRA Band 31	462,5 - 467,5 MHz	-40,4 dBm	-40,4 dBm	1 MHz	This requirement shall not apply to BS operating in band 31, or 72
	452,5 - 457,5 MHz	-37,4 dBm	-43,4 dBm	1 MHz	This requirement shall not apply to BS operating in band 31, since it is already covered by the requirement in clause 4.3.16.2.2 This requirement shall not apply to BS operating in band 72
UTRA FDD Band XXXII or E-UTRA Band 32	1 452 - 1 496 MHz	-40,4 dBm	-40,4 dBm	1 MHz	This requirement shall not apply to BS operating in band 32, 50 or 75
UTRA TDD Band a) or E-UTRA Band 33	1 900 - 1 920 MHz	-40,4 dBm	-43,4 dBm	1 MHz	This requirement shall not apply to BS operating in band 33
UTRA TDD Band e) or E-UTRA Band 40 or NR Band n40	2 300 - 2 400 MHz	-40,4 dBm	-43,4 dBm	1 MHz	This requirement is not applicable to BS operating in band 40
E-UTRA Band 42	3 400 - 3 600 MHz	-40,0 dBm	-43,0 dBm	1 MHz	This is not applicable to BS operating in band 22, 42, 43, 77 or 78
E-UTRA Band 43	3 600 - 3 800 MHz	-40,0 dBm	-43,0 dBm	1 MHz	This is not applicable to BS operating in band 42, 43, 77 or 78
E-UTRA Band 50 or NR Band n50	1 432 - 1 517 MHz	-40,4 dBm	-43,4 dBm	1 MHz	This requirement shall not apply to BS operating in band 32, 50, 51, 75 or 76
E-UTRA Band 51 or NR Band n51	1 427 - 1 432 MHz	-40,4 dBm	-43,4 dBm	1 MHz	This requirement shall not apply to BS operating in band 50, 51, 75 or 76
E-UTRA Band 65 or NR band n65	2 110 - 2 200 MHz	-40,4 dBm	-43,4 dBm	1 MHz	This requirement shall not apply to BS operating in band 1 or 65
	1 920 - 2 010 MHz	-37,4 dBm	-40,4 dBm	1 MHz	This requirement shall not apply to BS operating in band 65, since it is already covered by the requirement in clause 4.3.16.2.2 For BS operating in Band 1, it shall apply for 1 980 MHz to 2 010 MHz, while the rest is covered in clause 4.3.16.2.2
E-UTRA Band 67	738 - 758 MHz	-40,4 dBm	-43,4 dBm	1 MHz	This requirement shall not apply to BS operating in band 28/n28 or 67
E-UTRA Band 68	753 - 783 MHz	-40,4 dBm	-43,4 dBm	1 MHz	This requirement shall not apply to BS operating in band 28 or 68
	698 - 728 MHz	-37,4 dBm	-40,4 dBm	1 MHz	This requirement shall not apply to BS operating in band 68, since it is already covered by the requirement in clause 4.3.16.2.2 For BS operating in Band 28, it shall apply between 698 MHz and 703 MHz, while the rest is covered in clause 4.3.16.2.2

System type to co-exist with	Frequency range for co-existence requirement	Limit for MSR and E-UTRA	Limit for UTRA	Measurement Bandwidth	Note
E-UTRA Band 69	2 570 - 2 620 MHz	-40,4 dBm	-43,4 dBm	1 MHz	This requirement shall not apply to BS operating in band 69
E-UTRA Band 72	461 - 466 MHz	-40,4 dBm	-40,4 dBm	1 MHz	This requirement shall not apply to BS operating in band 31, or 72
	451 - 456 MHz	-37,4 dBm	-37,4 dBm	1 MHz	This requirement shall not apply to BS operating in band 72, since it is already covered by the requirement in clause 4.3.16.2.2
E-UTRA Band 75 or NR Band n75	1 432 - 1 517 MHz	-40,4 dBm	-43,4 dBm	1 MHz	This requirement shall not apply to BS operating in band 32, 50, 51, 75 or 76
E-UTRA Band 76 or NR Band n76	1 427 - 1 432 MHz	-40,4 dBm	-43,4 dBm	1 MHz	This requirement shall not apply to BS operating in band 50, 51, 75 or 76
NR Band n77	3 300 - 4 200 MHz	-40,0 dBm	-43,0 dBm	1 MHz	This requirement is not applicable to BS operating in band 22, 42, 43, 77 or 78
NR Band n78	3 300 - 3 800 MHz	-40,0 dBm	-43,0 dBm	1 MHz	This requirement is not applicable to BS operating in band 22, 42, 43, 77 or 78
E-UTRA Band 87	420 - 425 MHz	-40,4 dBm	-40,4 dBm	1 MHz	This requirement shall not apply to BS operating in band 87 or 88
	410 - 415 MHz	-37,4 dBm	-37,4 dBm	1 MHz	This requirement shall not apply to BS operating in band 87, since it is already covered by the requirement in clause 4.3.16.2.2
E-UTRA Band 88	422 - 427 MHz	-40,4 dBm	-40,4 dBm	1 MHz	This requirement shall not apply to BS operating in band 87 or 88
	412 - 417 MHz	-37,4 dBm	-37,4 dBm	1 MHz	This requirement shall not apply to BS operating in band 88, since it is already covered by the requirement in clause 4.3.16.2.2. This requirement shall not apply to BS operating in band 87
NR Band n91	1 427 to 1 432 MHz	-40,4 dBm	-43,4 dBm	1 MHz	This requirement shall not apply to AAS BS operating in band 50, 51, 75, 76, 91, 92, 93 or 94.
	832 to 862 MHz	-37,4 dBm	-40,4 dBm	1 MHz	This requirement shall not apply to AAS BS operating in band 20, since it is already covered by the requirement in clause 4.3.16.2.2.
NR Band n92	1 432 to 1 517 MHz	-40,4 dBm	-43,4 dBm	1 MHz	This requirement shall not apply to AAS BS operating in band 50, 51, 75, 76, 91, 92, 93 or 94.
	832 to 862 MHz	-37,4 dBm	-40,4 dBm	1 MHz	This requirement shall not apply to AAS BS operating in band 20, since it is already covered by the requirement in clause 4.3.16.2.2.
NR Band n93	1 427 to 1 432 MHz	-40,4 dBm	-43,4 dBm	1 MHz	This requirement shall not apply to AAS BS operating in Band 50, 51, 75, 76, 91, 92, 93 or 94.
	880 to 915 MHz	-37,4 dBm	-40,4 dBm	1 MHz	This requirement shall not apply to AAS BS operating in band 8, since it is already covered by the requirement in clause 4.3.16.2.2.
NR Band n94	1 432 to 1 517 MHz	-40,4 dBm	-43,4 dBm	1 MHz	This requirement shall not apply to AAS BS operating in Band 50, 51, 75, 76, 91, 92, 93 or 94.
	880 to 915 MHz	-37,4 dBm	-40,4 dBm	1 MHz	This requirement shall not apply to AAS BS operating in band 8, since it is already covered by the requirement in clause 4.3.16.2.2.

4.3.16.2.4 Additional limits

The following requirement shall apply to AAS BS operating in bands 50 and 75 within 1 432 MHz - 1 452 MHz, and in band 51 and band 76. Emissions shall not exceed the limits specified in table 4.3.16.2.4-1. This requirement is also applicable at the frequency range from Δf_{OBUE} below the lowest frequency of the BS downlink *operating band* up to Δf_{OBUE} above the highest frequency of the BS downlink *operating band*.

Table 4.3.16.2.4-1: Additional emission limit for AAS BS operating in bands 50 and 75 within 1 432 MHz - 1 452 MHz, and in bands 51 and 76

Filter centre frequency, F_{filter}	TRP Limit	Measurement bandwidth
$F_{\text{filter}} = 1\,413,5\text{ MHz}$	-42 dBm	27 MHz

The following limit shall apply to AAS BS operating in bands 50 and 75 within 1 492 MHz - 1 517 MHz. The emissions measured as EIRP, on centre frequencies F_{filter} with filter bandwidth according to table 4.3.16.2.4-2, shall not exceed the EIRP limit, in any direction.

Table 4.3.16.2.4-2: Additional emission limits for AAS BS operating in bands 50 and 75

Filter centre frequency, F_{filter}	EIRP limit	Measurement bandwidth
$1\,518,5\text{ MHz} \leq F_{\text{filter}} \leq 1\,519,5\text{ MHz}$	-0,8 dBm	1 MHz
$1\,520,5\text{ MHz} \leq F_{\text{filter}} \leq 1\,558,5\text{ MHz}$	-30 dBm	1 MHz

4.3.16.3 Conformance

The conformance tests for this requirement shall be as defined in clause 5.3.15 of the present document.

4.3.17 Radiated transmit power

4.3.17.1 Definition and applicability

This is an output power accuracy requirement defined at the RIB during the *transmitter ON period*. Radiated transmit power is defined as the EIRP level for a *beam* at a specific *beam peak direction*:

- For each *beam*, the requirement is based on following information:
 - *beam* identifier (D9.3)
 - *reference beam direction pair* (D9.7)
 - *rated beam EIRP* (D9.10) at the *reference beam direction pair*
 - *OTA peak directions set* (D9.8)
 - *beam direction pairs* at the maximum steering directions (D9.9) and their associated *rated beam EIRP* and *beamwidth(s)* (D9.11)

NOTE: For a *beam* identifier and *beam direction pair*, the *rated beam EIRP* level is the maximum power that the base station is intended to radiate at the associated *beam peak direction* during the *transmitter ON period*.

For *operating bands* where the supported *fractional bandwidth* (FBW) is not less than 6%, the BS can support two rated beam EIRP:

- $P_{\text{rated,c,FBWlow}}$ for lower supported frequency range (D11.33); and
- $P_{\text{rated,c,FBWhigh}}$ for higher supported frequency range (D11.34).

For frequencies in between F_{FBWlow} and F_{FBWhigh} the rated carrier EIRP is:

- $P_{\text{rated,c,FBWlow}}$, for the carrier whose carrier frequency is within frequency range $F_{\text{FBWlow}} \leq f < (F_{\text{FBWlow}} + F_{\text{FBWhigh}}) / 2$;

- $P_{\text{rated,c,FBWhigh}}$, for the carrier whose carrier frequency is within frequency range $(F_{\text{FBWlow}} + F_{\text{FBWhigh}}) / 2 \leq f \leq F_{\text{FBWhigh}}$.

4.3.17.2 Limits

For each conformance *beam direction pair*, in normal and extreme test environments, the *maximum carrier EIRP*, $P_{\text{max,c,EIRP}}$, for UTRA, E-UTRA and NR shall remain within the values provided in table 4.3.17.2-1, relative to *rated beam EIRP* value(s).

Table 4.3.17.2-1: Requirements for radiated transmit power

BS type	Frequency	Normal test environment	Extreme test environment
OTA AAS BS	$f \leq 3,0$ GHz	$\pm 3,3$ dB	$\pm 5,2$ dB
	$3,0$ GHz $< f \leq 4,2$ GHz	$\pm 3,5$ dB	$\pm 5,3$ dB

4.3.17.3 Conformance

The conformance tests for this requirement shall be as defined in clause 5.3.17 of the present document.

4.3.18 OTA Maximum output power

4.3.18.1 Definition and applicability

This is an output power accuracy requirement defined at the RIB during the *transmitter ON period*. OTA BS output power is expressed as TRP.

NOTE: The *BS class specific rated carrier output power* limits are described in ETSI TS 137 145-2 [3], clause 6.3.2.1.

For *BS* operating from 2 390 MHz to 2 400 MHz there is an additional requirement on the maximum output power.

4.3.18.2 Limits

The *maximum carrier TRP*, $P_{\text{max,c,TRP}}$, shall for UTRA, E-UTRA and NR remain within the values provided in table 4.3.18.2-1, relative to *rated carrier TRP*, $P_{\text{rated,c,TRP}}$:

Table 4.3.18.2-1: Requirements for radiated transmit power

BS type	Frequency	Normal test environment
OTA AAS BS	$f \leq 3,0$ GHz	$\pm 3,4$ dB
	$3,0$ GHz $< f \leq 4,2$ GHz	$\pm 3,5$ dB

In addition, for *BS* operating from 2 390 MHz to 2 400 MHz, the *maximum carrier TRP* shall not exceed 31 dBm/(5MHz).

4.3.18.3 Conformance

The conformance tests for this requirement shall be as defined in clause 5.3.18 of the present document.

4.3.19 OTA transmitter intermodulation

4.3.19.1 Definition and applicability

The OTA transmitter intermodulation requirement is a measure of the capability of the transmitter unit to inhibit the generation of signals in its non-linear elements caused by presence of the wanted signal and an interfering signal reaching the transmitter unit via the RDN and antenna array from a co-located base station. The requirement applies during the *transmitter ON period* and the *transmitter transient period*.

The requirement applies at each RIB supporting transmission in the *operating band*.

The transmitter intermodulation level is the *total radiated power* of the intermodulation products when an interfering signal is injected into the CLTA.

For *OTA AAS BS*, the transmitter intermodulation requirement is captured by the co-location transmitter intermodulation scenario case, in which the interfering signal is injected into the CLTA.

4.3.19.2 Limits

4.3.19.2.1 Limits for *MSR operation*

4.3.19.2.1.1 General limit

For a RIB supporting operation in BC1, BC2 and BC3, the transmitter intermodulation level shall not exceed the unwanted emission limits specified for transmitter spurious emission in clause 4.3.16, *operating band unwanted emission* in clause 4.3.13 and ACLR in clause 4.3.15 in the presence of a wanted signal and an interfering signal according to table 4.3.19.2.1.1-1.

The requirement is applicable outside the edges of the *Base Station RF Bandwidth*. The interfering signal offset is defined relative to the *Base Station RF Bandwidth edges* or *Maximum Radio Bandwidth edges*.

For *RIB* supporting operation in *non-contiguous spectrum*, the requirement is also applicable inside a *sub-block gap* for interfering signal offsets where the interfering signal falls completely within the *sub-block gap*. The interfering signal offset is defined relative to the *sub-block edges*.

For *multi-band RIBs*, the requirement applies relative to the *Base Station RF Bandwidth edges* of each *operating band*. In case the *inter RF Bandwidth gap* is less than 15 MHz, the requirement in the gap applies only for interfering signal offsets where the interfering signal falls completely within the *inter RF Bandwidth gap*.

Table 4.3.19.2.1.1-1: Interfering and wanted signals for the OTA transmitter intermodulation requirement

Parameter	Value
Wanted signal type	E-UTRA or NR signal
Interfering signal type	E-UTRA signal of <i>channel bandwidth</i> 5 MHz
Interfering signal power level applied to the CLTA	min(46 dBm, $P_{\text{rated,t,TRP}}$)
Interfering signal centre frequency offset from <i>Base Station RF Bandwidth edge</i> or edge of <i>sub-block</i> inside a gap	$\pm 2,5$ MHz $\pm 7,5$ MHz $\pm 12,5$ MHz
NOTE 1: Interfering signal positions that are partially or completely outside of any <i>downlink operating band</i> of the RIB is excluded from the requirement, unless the interfering signal positions fall within the frequency range of adjacent <i>downlink operating bands</i> listed in table 1-1. In case that none of the interfering signal positions fall completely within the frequency range of the <i>downlink operating band</i> , the test suite in clause 5.3.19 provides further guidance.	
NOTE 2: For <i>OTA AAS BS</i> with dual polarization, the interfering signal power shall be equally divided between the supported polarizations at the CLTA.	

4.3.19.2.1.2 Additional limit (BC1 and BC2)

For a RIB supporting operation in BC2, the transmitter intermodulation level shall not exceed the unwanted emission limits specified for transmitter spurious emission in clause 4.3.16, *operating band unwanted emission* in clause 4.3.13 and ACLR in clause 4.3.15 in the presence of a wanted signal and an interfering signal according to table 4.3.19.2.1.2-1.

The requirement is applicable outside the edges of the *Base Station RF Bandwidth* for BC2. The interfering signal offset is defined relative to the *Base Station RF Bandwidth edges*.

For *RIBs* supporting operation in *non-contiguous spectrum* in BC1 or BC2, the requirement is also applicable inside a *sub-block gap* with a gap size not less than two times the interfering signal centre frequency offset. For *RIBs* supporting operation in *non-contiguous spectrum* in BC1, the requirement is not applicable inside a *sub-block gap* with a gap size equal to or more than 5 MHz. The interfering signal offset is defined relative to the *sub-block edges*.

For *multi-band RIBs*, the requirement applies relative to the *Base Station RF Bandwidth edges* of a *BC2 operating band*. The requirement is also applicable for BC1 and BC2 inside an *inter RF Bandwidth gap* equal to or more than two times the interfering signal centre frequency offset. For *RIBs* supporting operation in multiple *operating bands*, the requirement is not applicable for BC1 band inside an *inter RF Bandwidth gap* with a gap size equal to or more than 5 MHz.

Table 4.3.19.2.1.2-1: Interfering and wanted signals for the OTA transmitter intermodulation requirement

Parameter	Value
Wanted signal type	E-UTRA and/or NR UTRA signal
Interfering signal type	CW
Interfering signal power level applied to the CLTA	min(46 dBm, $P_{\text{rated,t,TRP}}$)
Interfering signal centre frequency offset from <i>Base Station RF Bandwidth edge</i> or edge of <i>sub-block</i> inside a gap	> 800 kHz for CW interferer
NOTE 1: Interfering signal positions that are partially or completely outside of any <i>downlink operating band</i> of the RIB are excluded from the requirement.	
NOTE 2: For <i>OTA AAS BS</i> with dual polarization, the interfering signal power shall be equally divided between the supported polarizations at the CLTA.	

4.3.19.2.2 Limits for single RAT UTRA operation

4.3.19.2.2.1 General limit for UTRA FDD

For *RIBs* supporting only *single RAT UTRA operation*, the transmitter intermodulation level shall not exceed the out of band emission or the spurious emission requirements of clause 4.3.14 (OTA spectrum mask) and clause 4.3.16 (OTA spurious emission), in the presence of interfering signal according to table 4.3.19.2.2.1-1.

For *RIBs* supporting operation in *non-contiguous spectrum*, the requirement is also applicable inside a *sub-block gap* for interfering signal offsets where the interfering signal falls completely within the *sub-block gap*. The interfering signal offset is defined relative to the *sub-block edges*.

For *multi-band RIBs*, the requirement is also applicable inside an *Inter RF Bandwidth gap* for interfering signal offsets where the interfering signal falls completely within the *Base Station RF Bandwidth gap*.

Table 4.3.19.2.2.1-1: Interfering and wanted signal frequency offset for OTA transmitter intermodulation requirement

Parameter	Value
Wanted signal type	UTRA
Interfering signal type	UTRA
Interfering signal power level applied to the CLTA	min(46 dBm, $P_{\text{rated,t,TRP}}$)
Interfering signal centre frequency offset from the lower (upper) edge of the wanted signal or edge of <i>sub-block</i> inside a gap	-2,5 MHz -7,5 MHz -12,5 MHz +2,5 MHz +7,5 MHz +12,5 MHz
NOTE 1: Interference frequencies that are outside of any allocated frequency band for UTRA-FDD downlink are excluded from the requirement, unless the interfering signal positions fall within the frequency range of adjacent <i>downlink operating bands</i> in table 1-1.	
NOTE 2: For <i>OTA AAS BS</i> with dual polarization, the interfering signal power shall be equally divided between the supported polarizations at the CLTA.	

4.3.19.2.3 Limits for single RAT E-UTRA operation

4.3.19.2.3.1 General limit

For RIBs supporting only *single RAT E-UTRA operation*, the transmitter intermodulation level shall not exceed the unwanted emission limits specified for transmitter spurious emission in clause 4.3.16, *operating band unwanted emission* in clause 4.3.13 and ACLR in clause 4.3.15 in the presence of an E-UTRA interfering signal according to according to table 4.3.19.2.3.1-1.

The requirement is applicable outside the *Base Station RF Bandwidth* or *Maximum Radio Bandwidth*. The interfering signal offset is defined relative to the *Base Station RF Bandwidth edges* or *Maximum Radio Bandwidth edges*.

For RIBs supporting operation in *non-contiguous spectrum*, the requirement is also applicable inside a *sub-block gap* for interfering signal offsets where the interfering signal falls completely within the *sub-block gap*. The interfering signal offset is defined relative to the *sub-block edges*.

For *multi-band RIBs*, the requirement applies relative to the *Base Station RF Bandwidth edges* of each supported *operating band*. In case the *Inter RF Bandwidth gap* is less than 15 MHz, the requirement in the gap applies only for interfering signal offsets where the interfering signal falls completely within the *inter RF Bandwidth gap*.

Table 4.3.19.2.3.1-1: Interfering and wanted signals for the OTA transmitter intermodulation requirement

Parameter	Value
Wanted signal	E-UTRA single carrier, or multi-carrier, or multiple intra-band contiguously or non-contiguously aggregated carriers
Interfering signal type	E-UTRA signal of <i>channel bandwidth</i> 5 MHz
Interfering signal power level applied to the CLTA	min(46 dBm, $P_{\text{rated,t,TRP}}$)
Interfering signal centre frequency offset from the lower (upper) edge of the wanted signal or edge of <i>sub-block</i> inside a <i>sub-block gap</i>	$\pm 2,5$ MHz $\pm 7,5$ MHz $\pm 12,5$ MHz
NOTE 1: Interfering signal positions that are partially or completely outside of any <i>downlink operating band</i> of the base station are excluded from the requirement, unless the interfering signal positions fall within the frequency range of adjacent <i>downlink operating bands</i> in table 1-1.	
NOTE 2: For <i>OTA AAS BS</i> with dual polarization, the interfering signal power shall be equally divided between the supported polarizations at the CLTA.	

4.3.19.3 Conformance

The conformance tests for this requirement shall be as defined in clause 5.3.19 of the present document.

4.3.20 OTA receiver spurious emissions

4.3.20.1 Definition and applicability

The receiver spurious emission requirement is the power of the emissions radiated from the antenna array from a receiver unit. For an *OTA AAS BS* operating in FDD, OTA RX spurious emissions requirement do not apply as they are superseded by the OTA TX spurious emissions requirement. This is due to the fact that TX and RX spurious emissions cannot be distinguished in OTA domain.

The OTA receiver spurious emission limits shall apply from 9 kHz to 12,75 GHz, excluding the following RAT-specific frequency ranges:

- for RIB supporting *MSR operation*, from Δf_{OBUE} below the lowest frequency of the *downlink operating band* up to Δf_{OBUE} above the highest frequency of the *downlink operating band*, where Δf_{OBUE} is defined in table 4.3.13.1-1;
- for RIB supporting only *single RAT UTRA operation*, from 12,5 MHz below the *lowest carrier* frequency used up to 12,5 MHz above the *highest carrier* frequency used;

- for RIB supporting only *single RAT E-UTRA operation*, from Δf_{OBUE} below the lowest frequency of the *downlink operating band* up to Δf_{OBUE} above the highest frequency of the *downlink operating band*, where Δf_{OBUE} is defined in table 4.3.13.1-1.

For *bands 7,22, 38, 41, 42, 43, 77 and 78* the upper frequency limit is higher than 12,75 GHz in order to comply with the 5th harmonic limit of the *downlink operating band*, as specified in Recommendation ITU-R SM.329-12 [i.4].

For an *OTA AAS BS* operating in TDD, the OTA receiver spurious emissions requirement applies during the *transmitter OFF period* only.

For RX only *multi-band RIB*, the RX spurious emissions requirements are subject to exclusion zones in each supported *operating band*.

4.3.20.2 Limits

The TRP of any spurious emission shall not exceed the limits in table 4.3.20.2-1.

In addition to the limits in table 4.3.20.2-1, the TRP of any spurious emission shall not exceed the limits specified in clauses 4.3.16.2.2, 4.3.16.2.3 and 4.3.16.2.4.

Table 4.3.20.2-1: Receiver spurious emission limit

Frequency range (note 4)	Limit (notes 2, 3)	Measurement bandwidth	NOTE
30 MHz - 1 GHz	-36 dBm	100 kHz	note 1
1 GHz - 12,75 GHz	-30 dBm	1 MHz	note 1, note 2
12,75 GHz - 5 th harmonic of the upper frequency edge of the UL <i>operating band</i> in GHz	-30 dBm	1 MHz	notes 1, 2 and 3
NOTE 1: <i>Measurement bandwidths</i> as in Recommendation ITU-R SM.329-12 [i.4], section 4.1.			
NOTE 2: Upper frequency as in Recommendation ITU-R SM.329-12 [i.4], section 2.5 table 1.			
NOTE 3: This spurious frequency range applies only for <i>operating bands</i> for which the 5 th harmonic of the upper frequency edge of the UL <i>operating band</i> is reaching beyond 12,75 GHz.			
NOTE 4: The frequency range between $2,5 \times \text{channel bandwidth}$ below the first carrier frequency and $2,5 \times \text{channel bandwidth}$ above the last carrier frequency transmitted by the AAS BS may be excluded from the requirement. However, frequencies that are more than Δf_{OBUE} below the lowest frequency of any of the AAS BS supported <i>downlink operating band</i> or more than Δf_{OBUE} above the highest frequency of any of the AAS BS supported <i>downlink operating band</i> shall not be excluded from the requirement. For a <i>multi-band RIB</i> , the exclusion applies for all supported <i>operating bands</i> .			

4.3.20.3 Conformance

The conformance tests for this requirement shall be as defined in clause 5.3.20 of the present document.

4.3.21 OTA blocking

4.3.21.1 Definition and applicability

The blocking characteristics are a measure of the receiver unit ability to receive a wanted signal at the RIB at its assigned channel in the presence of an unwanted interferer.

The requirement applies at the *RIB* when the AoA of the incident wave of the received signal and the interfering signal are the same direction and are within the *minSENS RoAoA*.

The wanted signal applies to each supported polarization, under the assumption of *polarization match*. The interferer shall be polarization matched for in-band frequencies and the polarization maintained for out-of-band frequencies.

4.3.21.2 Limits

4.3.21.2.1 Limits for *MSR operation*

For a wanted and an interfering signal specified at the RIB using the parameters in table 4.3.21.2.1-1, the following requirements shall apply:

- For any UTRA FDD carrier, the BER shall not exceed 0,001 for the reference measurement channel specified in clause 4.3.25.2.1.
- For any E-UTRA carrier, the *throughput* shall be ≥ 95 % of the *maximum throughput* of the reference measurement channel specified in clause 4.3.25.2.2.
- For any NR carrier, the *throughput* shall be ≥ 95 % of the *maximum throughput* of the reference measurement channel specified in clause 4.3.25.2.3.

For *multi-band RIB*, the requirement applies for each supported *operating band*. The in-band blocking frequency ranges of all supported *operating bands* according to table 4.3.21.2.1-1 shall be excluded from the requirement.

The OTA blocking requirement applies from 30 MHz to $F_{UL_low} - \Delta f_{OOB}$ and from $F_{UL_high} + \Delta f_{OOB}$ up to 12,75 GHz, including the downlink frequency range of the FDD *operating band* for BS supporting FDD. Δf_{OOB} is defined in clause 4.3.23.1.

Table 4.3.21.2.1-1: Blocking requirement

Wanted signal mean power (dBm)	Interfering signal RMS field-strength (V/m)	Type of interfering signal
EIS _{minSENS} + 6 dB (note)	0,36 V/m	CW carrier
NOTE: EIS _{minSENS} depends on the RAT, the BS class and the channel bandwidth, see clause 4.3.24.		

NOTE: The RMS field-strength level in V/m is related to the interferer EIRP level at a distance described as

$$E = \frac{\sqrt{30EIRP}}{r}, \text{ where EIRP is in W and r is in m; for example, 0,36 V/m is equivalent to 36 dBm at fixed distance of 30 m.}$$

4.3.21.2.2 Limits for *Single RAT UTRA operation*

Following requirements apply for RIBs supporting only *single RAT UTRA operation*.

In addition to the following in-band and narrowband requirements, the general limits relating to out of band blocking defined for MSR in clause 4.3.21.2.1-1 shall also be applied for *single RAT UTRA operation*.

The limit for in-band blocking and narrowband blocking UTRA operation is defined below.

The requirement is applicable outside the *Base Station RF Bandwidth* or *Maximum Radio Bandwidth*. The interfering signal offset is defined relative to the *Base Station RF Bandwidth edges* or *Maximum Radio Bandwidth edges* applicable to each *RIB*.

For *RIB* supporting operation in *non-contiguous spectrum*, the requirement applies in addition inside any *sub-block gap*, in case the *sub-block gap* size is at least 15 MHz. The interfering signal offset is defined relative to the *sub-block edges* inside the *sub-block gap* and is equal to -7,5 MHz/+7,5 MHz, respectively.

For a *RIB* supporting operation in *non-contiguous spectrum* the narrowband blocking requirement applies in addition inside any *sub-block gap*, in case the *sub-block gap* size is at least 400 kHz or 600 kHz, depending on the *operating band*. The interfering signal offset is defined relative to the *sub-block edges* inside the *sub-block gap* and is equal to -200 kHz/+200 kHz or -300 kHz/+300 kHz, respectively.

For *multi-band RIBs* the requirement in the in-band blocking frequency range applies for each supported *operating band*. The requirement applies in addition inside any *Inter RF Bandwidth gap*, in case *Inter RF Bandwidth gap* size is at least 15 MHz. The interfering signal offset is defined relative to lower/upper *Base Station RF Bandwidth edges* inside the *Inter RF Bandwidth gap* and is equal to -7,5 MHz/+7,5 MHz, respectively.

For *multi-band RIBs* the narrowband blocking requirement applies in addition inside any *Inter RF Bandwidth gap*, in case the *Inter RF Bandwidth gap* size is at least 400 kHz or 600 kHz, depending on the *operating band*. The interfering signal offset is defined relative to lower/upper *Base Station RF Bandwidth edges* inside the *Inter RF Bandwidth gap* and is equal to -200 kHz/+200 kHz or -300 kHz/+300 kHz, respectively.

For the wanted and interfering signal at the *RIB*, using the parameters in tables 4.3.21.2.2-1 and 4.3.21.2.2-2, the following requirements shall apply:

- For any UTRA FDD carrier, the BER shall not exceed 0,001 for the reference measurement channel specified in clause 4.3.25.2.1.

The OTA levels are applied referenced to two antenna gain offsets $\Delta_{\text{OTAREFSENS}}$ and Δ_{minSENS} .

Table 4.3.21.2.2-1: In-band blocking requirement for *single RAT UTRA operation*

Base Station Type	Mean power of interfering signal [dBm]	Wanted Signal mean power [dBm]	Minimum Offset of Interfering Signal	Type of Interfering Signal
Wide Area BS	$-40 - \Delta_{\text{OTAREFSENS}}$	$\text{EIS}_{\text{REFSENS}} + 6 \text{ dB}$	$\pm 10 \text{ MHz}$	WCDMA signal (note 1)
	$-40 - \Delta_{\text{minSENS}}$	$\text{EIS}_{\text{minSENS}} + 6 \text{ dB}$		
Medium Range BS	$-35 - \Delta_{\text{OTAREFSENS}}$	$\text{EIS}_{\text{REFSENS}} + 6 \text{ dB}$		
	$-35 - \Delta_{\text{minSENS}}$	$\text{EIS}_{\text{minSENS}} + 6 \text{ dB}$		
Local Area BS	$-30 - \Delta_{\text{OTAREFSENS}}$	$\text{EIS}_{\text{REFSENS}} + 6 \text{ dB}$		
	$-30 - \Delta_{\text{minSENS}}$	$\text{EIS}_{\text{minSENS}} + 6 \text{ dB}$		
NOTE 1: The characteristics of the WCDMA interfering signal are specified in ETSI TS 125 104 [10], annex C.				
NOTE 2: For <i>multi-band RIBs</i> , in case of interfering signal that is not in the in-band blocking frequency range of the <i>operating band</i> where the wanted signal is present, and not in the in-band blocking frequency range of an adjacent or overlapping operating band, the wanted signal mean power is equal to $-119,6 - \Delta_{\text{OTAREFSENS}}$ dBm or $-119,6 - \Delta_{\text{minSENS}}$ dBm as appropriate.				

Table 4.3.21.2.2-2: Blocking requirement (narrowband) for *single RAT UTRA operation*

Base Station Type	Mean power of interfering signal [dBm]	Wanted Signal mean power [dBm]	Minimum Offset of Interfering Signal	Type of Interfering Signal	
Wide Area BS	$-47 - \Delta_{\text{OTAREFSENS}}$	$\text{EIS}_{\text{REFSENS}} + 6 \text{ dB}$	$\pm 2,7 \text{ MHz}$ (note 2)	GMSK modulated (note 1)	
	$-47 - \Delta_{\text{minSENS}}$	$\text{EIS}_{\text{minSENS}} + 6 \text{ dB}$			
Medium Range BS	$-42 - \Delta_{\text{OTAREFSENS}}$	$\text{EIS}_{\text{REFSENS}} + 6 \text{ dB}$			$\pm 2,8 \text{ MHz}$ (note 3)
	$-42 - \Delta_{\text{minSENS}}$	$\text{EIS}_{\text{minSENS}} + 6 \text{ dB}$			
Local Area BS	$-37 - \Delta_{\text{OTAREFSENS}}$	$\text{EIS}_{\text{REFSENS}} + 6 \text{ dB}$			
	$-37 - \Delta_{\text{minSENS}}$	$\text{EIS}_{\text{minSENS}} + 6 \text{ dB}$			
NOTE 1: GMSK modulation as defined in ETSI TS 145 004 [8].					
NOTE 2: applies for band VIII.					
NOTE 3: applies for bands III, VIII.					

4.3.21.2.3 Limits for *single RAT E-UTRA operation*

Following requirements apply for *RIBs* supporting only *single RAT E-UTRA operation*.

In addition to the following in-band and narrowband requirements, the general limits relating to out of band blocking defined for MSR in table 4.3.21.2.1-1 shall also be applied for *single RAT E-UTRA operation*.

The limit for in-band blocking E-UTRA operation is defined below:

The requirement is applicable outside the *Base Station RF Bandwidth* or *Maximum Radio Bandwidth*. The interfering signal offset is defined relative to the *Base Station RF Bandwidth edges* or *Maximum Radio Bandwidth edges* applicable to each *RIB*.

For *RIB* supporting operation in *non-contiguous spectrum*, the requirement applies in addition inside any *sub-block gap*, in case the *sub-block gap* size is at least 15 MHz. The interfering signal offset is defined relative to the *sub-block edges* inside the *sub-block gap*.

For *multi-band RIBs*, the requirement applies in addition inside any *Inter RF Bandwidth gap*, in case the gap size is at least 15 MHz. The interfering signal offset is defined relative to the *Base Station RF Bandwidth edges* inside the *Inter RF Bandwidth gap*.

For the wanted and interfering signal at the *RIB*, using the parameters in tables 4.3.21.2.3.1 and 4.3.21.2.3-2, the following requirements shall apply:

- For any E-UTRA carrier, the *throughput* shall be ≥ 95 % of the *maximum throughput* of the reference measurement channel specified in clause 4.3.25.2.2.

The OTA levels are applied referenced to two antenna gain offsets $\Delta_{\text{OTAREFSENS}}$ and Δ_{minSENS} .

For *multi-band RIBs*, the requirement applies according to table 4.3.21.2.3-1 for the in-band blocking frequency ranges of each supported *operating band*.

Table 4.3.21.2.3-1: In-band blocking requirement for single RAT E-UTRA

Base Station Type	Mean power of interfering signal [dBm]	Wanted Signal mean power [dBm] (notes 1 and 2)	Type of Interfering Signal	Interfering signal centre frequency minimum frequency offset from the <i>Base Station RF Bandwidth edge</i> or <i>edge of sub-block</i> inside a gap [MHz]
Wide Area BS	$-43 - \Delta_{\text{OTAREFSENS}}$	$\text{EIS}_{\text{REFSENS}} + 6$ dB	See table 4.3.21.2.3-2	See table 4.3.21.2.3-2
	$-43 - \Delta_{\text{minSENS}}$	$\text{EIS}_{\text{minSENS}} + 6$ dB		
Medium Range BS	$-38 - \Delta_{\text{OTAREFSENS}}$	$\text{EIS}_{\text{REFSENS}} + 6$ dB		
	$-38 - \Delta_{\text{minSENS}}$	$\text{EIS}_{\text{minSENS}} + 6$ dB		
Local Area BS	$-35 - \Delta_{\text{OTAREFSENS}}$	$\text{EIS}_{\text{REFSENS}} + 6$ dB		
	$-35 - \Delta_{\text{minSENS}}$	$\text{EIS}_{\text{minSENS}} + 6$ dB		
NOTE 1: $\text{EIS}_{\text{REFSENS}}$ and $\text{EIS}_{\text{minSENS}}$ depend on the RAT, the <i>BS class</i> and on the <i>channel bandwidth</i> , see clauses 10.3 and 10.2 in ETSI TS 137 105 [1].				
NOTE 2: For <i>multi-band RIBs</i> , in case of interfering signal that is not in the in-band blocking frequency range of the <i>operating band</i> where the wanted signal is present, and not in the in-band blocking frequency range of an adjacent or overlapping operating band, the wanted signal mean power is equal to $\text{EIS}_{\text{REFSENS}} + 1,4$ dB or $\text{EIS}_{\text{minSENS}} + 1,4$ dB as appropriate.				

Table 4.3.21.2.3-2: Interfering signals for single RAT E-UTRA in-band blocking requirement

E-UTRA channel BW of the <i>lowest/highest carrier</i> received [MHz]	Interfering signal centre frequency minimum offset to the lower/upper <i>Base Station RF Bandwidth edge</i> or <i>sub-block edge</i> inside a <i>sub-block gap</i> [MHz]	Type of interfering signal
1,4	$\pm 2,1$	1,4 MHz E-UTRA signal
3	$\pm 4,5$	3 MHz E-UTRA signal
5	$\pm 7,5$	5 MHz E-UTRA signal
10	$\pm 7,5$	5 MHz E-UTRA signal
15	$\pm 7,5$	5 MHz E-UTRA signal
20	$\pm 7,5$	5 MHz E-UTRA signal
20	± 30	20 MHz E-UTRA signal

4.3.21.3 Conformance

The conformance tests for this requirement shall be as defined in clause 5.3.21 of the present document.

4.3.22 OTA receiver intermodulation

4.3.22.1 Definition and applicability

Third and higher order mixing of the two interfering RF signals can produce an interfering signal in the band of the desired channel. Intermodulation response rejection is a measure of the capability of the receiver unit to receive a wanted signal on its assigned channel frequency in the presence of two interfering signals which have a specific frequency relationship to the wanted signal.

The requirement applies at the RIB when the AoA of the incident wave of a received signal and the interfering signal are from the same direction, and:

- When the wanted signal is based on $EIS_{REFSENS}$: the AoA of the incident wave of a received signal and the interfering signal are within the *OTA REFSENS RoAoA*.
- When the wanted signal is based on $EIS_{minSENS}$: the AoA of the incident wave of a received signal and the interfering signal are within the *minSENS RoAoA*.

The wanted and interfering signals apply to each supported polarization, under the assumption of *polarization match*.

4.3.22.2 Limits

4.3.22.2.1 Limits for *MSR operation*

4.3.22.2.1.1 General intermodulation limit

Interfering signals shall be a CW signal and an E-UTRA, NR or UTRA signal as specified in ETSI TS 137 141 [6], annex A.

The requirement is applicable outside the *Base Station RF Bandwidth* or *Maximum Radio Bandwidth*. The interfering signal offset is defined relative to the *Base Station RF Bandwidth edges* or *Maximum Radio Bandwidth edges*.

For *multi-band RIBs*, the requirement applies in addition inside any *Inter RF Bandwidth gap* at those connectors, in case the gap size is at least twice as wide as the UTRA/E-UTRA interfering signal centre frequency offset from the *Base Station RF Bandwidth edge*. The interfering signal offset is defined relative to the *Base Station RF Bandwidth edges* inside the *Inter RF Bandwidth gap*.

For the wanted signal at the assigned channel frequency and two interfering signals at the RIB, using the parameters in tables 4.3.22.2.1.1-1 and 4.3.22.2.1.1-2, the following requirements shall apply:

- For any UTRA FDD carrier, the BER shall not exceed 0,001 for the reference measurement channel specified in clause 4.3.25.2.1.
- For any E-UTRA carrier, the *throughput* shall be ≥ 95 % of the *maximum throughput* of the reference measurement channel specified in clause 4.3.25.2.2.
- For any NR carrier, the *throughput* shall be ≥ 95 % of the *maximum throughput* of the reference measurement channel specified in clause 4.3.25.2.3.

The OTA levels are applied referenced to two antenna gain offsets $\Delta_{OTAREFSENS}$ and $\Delta_{minSENS}$.

Table 4.3.22.2.1.1-1: General intermodulation requirement

Base Station Type	Mean power of interfering signals [dBm]	Wanted Signal mean power [dBm] (note 1)	Type of interfering signal
Wide Area BS	$-48 + y - \Delta_{OTAREFSENS}$ (note 6)	$EIS_{REFSENS} + x$ dB (notes 2 and 5)	See table 4.3.22.2.1.1-2
	$-48 + y - \Delta_{minSENS}$ (note 6)	$EIS_{minSENS} + x$ dB (notes 2 and 5)	
Medium Range BS	$-44 + y - \Delta_{OTAREFSENS}$ (note 6)	$EIS_{REFSENS} + x$ dB (notes 3 and 5)	
	$-44 + y - \Delta_{minSENS}$ (note 6)	$EIS_{minSENS} + x$ dB (notes 3 and 5)	
Local Area BS	$-38 + y - \Delta_{OTAREFSENS}$ (note 6)	$EIS_{REFSENS} + x$ dB (notes 4 and 5)	
	$-38 + y - \Delta_{minSENS}$ (note 6)	$EIS_{minSENS} + x$ dB (notes 4 and 5)	
NOTE 1: $EIS_{REFSENS}$ and $EIS_{minSENS}$ depend on the RAT, the BS class and on the channel bandwidth, see clauses 4.3.24 and 4.3.25.			
NOTE 2: For Wide Area BS not supporting NR, "x" is equal to 6 in case of E-UTRA or UTRA wanted signals.			
NOTE 3: For Medium Range BS not supporting NR, "x" is equal to 6 in case of UTRA wanted signals, 9 in case of E-UTRA wanted signal.			
NOTE 4: For Local Area BS not supporting NR, "x" is equal to 12 in case of E-UTRA wanted signals, 6 in case of UTRA wanted signal.			
NOTE 5: For a BS supporting NR and not supporting UTRA, x is equal to 6.			
NOTE 6: For a BS not supporting NR, "y" is equal to zero for all BS classes. For a BS that supports NR and supporting UTRA; "y" is equal to -4 for the Wide Area BS, -3 for the Medium Range BS and -6 for the Local Area BS.			

Table 4.3.22.2.1.1-2: Interfering signals for intermodulation requirement

RAT of the carrier adjacent to the upper/lower Base Station RF Bandwidth edge	Interfering signal centre frequency offset from the Base Station RF Bandwidth edge [MHz]	Type of interfering signal
E-UTRA 1,4 MHz	$\pm 2,0$ (BC1 and BC3) / $\pm 2,1$ (BC2)	CW
	$\pm 4,9$	1,4 MHz E-UTRA signal
E-UTRA 3 MHz	$\pm 4,4$ (BC1 and BC3) / $\pm 4,5$ (BC2)	CW
	$\pm 10,5$	3 MHz E-UTRA signal
UTRA FDD and E-UTRA 5 MHz	$\pm 7,5$	CW
	$\pm 17,5$	5 MHz E-UTRA signal
E-UTRA 10 MHz	$\pm 7,375$	CW
	$\pm 17,5$	5 MHz E-UTRA signal
E-UTRA 15 MHz	$\pm 7,25$	CW
	$\pm 17,5$	5 MHz E-UTRA signal
E-UTRA 20 MHz	$\pm 7,125$	CW
	$\pm 17,5$	5 MHz E-UTRA signal
NR 5 MHz	$\pm 7,5$	CW
	$\pm 17,5$	5 MHz E-UTRA signal
NR 10 MHz	$\pm 7,465$	CW
	$\pm 17,5$	5 MHz E-UTRA signal
NR 15 MHz	$\pm 7,43$	CW
	$\pm 17,5$	5 MHz E-UTRA signal
NR 20 MHz	$\pm 7,395$	CW
	$\pm 17,5$	5 MHz E-UTRA signal
NR 25 MHz	$\pm 7,465$	CW
	± 25	20 MHz E-UTRA signal
NR 30 MHz	$\pm 7,43$	CW
	± 25	20 MHz E-UTRA signal
NR 40 MHz	$\pm 7,45$	CW
	± 25	20 MHz E-UTRA signal
NR 50 MHz	$\pm 7,35$	CW
	± 25	20 MHz E-UTRA signal
NR 60 MHz	$\pm 7,49$	CW
	± 25	20 MHz E-UTRA signal
NR 70 MHz	$\pm 7,42$	CW
	± 25	20 MHz E-UTRA signal

RAT of the carrier adjacent to the upper/lower <i>Base Station RF Bandwidth edge</i>	Interfering signal centre frequency offset from the <i>Base Station RF Bandwidth edge</i> [MHz]	Type of interfering signal
NR 80 MHz	$\pm 7,44$	CW
	± 25	20 MHz E-UTRA signal
NR 90 MHz	$\pm 7,46$	CW
	± 25	20 MHz E-UTRA signal
NR 100 MHz	$\pm 7,48$	CW
	± 25	20 MHz E-UTRA signal

4.3.22.2.1.2 General narrowband intermodulation limit

Interfering signals shall be a CW signal and an E-UTRA IRB signal, as specified in ETSI TS 137 141 [6], annex A.

The requirement is applicable outside the *Base Station RF Bandwidth* or *Maximum Radio Bandwidth*. The interfering signal offset is defined relative to the *Base Station RF Bandwidth edges* or *Maximum Radio Bandwidth edges*.

For RIB supporting operation in *non-contiguous spectrum* within each supported *operating band*, the requirement applies in addition inside any *sub-block gap* in case the *sub-block gap* is at least as wide as the *channel bandwidth* of the E-UTRA interfering signal in table 4.3.22.2.1.2-2. The interfering signal offset is defined relative to the *sub-block edges* inside the gap.

For *multi-band RIBs*, the requirement applies in addition inside any *Inter RF Bandwidth gap*, in case the gap size is at least as wide as the E-UTRA interfering signal in table 4.3.22.2.1.2-2. The interfering signal offset is defined relative to the *Base Station RF Bandwidth edges* inside the *Inter RF Bandwidth gap*.

For the wanted signal at the assigned channel frequency and two interfering signals at the RIB, using the parameters in tables 4.3.22.2.1.2-1 and 4.3.22.2.1.2-2, the following requirements shall apply:

- For any UTRA FDD carrier, the BER shall not exceed 0,001 for the reference measurement channel specified in clause 4.3.25.2.1.
- For any E-UTRA carrier, the *throughput* shall be ≥ 95 % of the *maximum throughput* of the reference measurement channel specified in clause 4.3.25.2.2.
- For any NR carrier, the *throughput* shall be ≥ 95 % of the *maximum throughput* of the reference measurement channel specified in clause 4.3.25.2.3.

The OTA levels are applied referenced to two antenna gain offsets $\Delta_{\text{OTAREFSENS}}$ and Δ_{minSENS} .

Table 4.3.22.2.1.2-1: General narrowband intermodulation requirement

Base Station Type	Mean power of interfering signals [dBm]	Wanted Signal mean power [dBm] (note)	Type of interfering signal
Wide Area BS	$-52 - \Delta_{\text{OTAREFSENS}}$	$\text{EIS}_{\text{REFSENS}} + 6$ dB	See table 4.3.22.2.1.2-2
	$-52 - \Delta_{\text{minSENS}}$	$\text{EIS}_{\text{minSENS}} + 6$ dB	
Medium Range BS	$-47 - \Delta_{\text{OTAREFSENS}}$	$\text{EIS}_{\text{REFSENS}} + 6$ dB	
	$-47 - \Delta_{\text{minSENS}}$	$\text{EIS}_{\text{minSENS}} + 6$ dB	
Local Area BS	$-44 - \Delta_{\text{OTAREFSENS}}$	$\text{EIS}_{\text{REFSENS}} + 6$ dB	
	$-44 - \Delta_{\text{minSENS}}$	$\text{EIS}_{\text{minSENS}} + 6$ dB	
NOTE: $\text{EIS}_{\text{REFSENS}}$ and $\text{EIS}_{\text{minSENS}}$ depend on the RAT, the <i>BS class</i> and on the <i>channel bandwidth</i> , see clauses 4.3.24 and 4.3.25.			

Table 4.3.22.2.1-2: Interfering signals for narrowband intermodulation requirement

RAT of the carrier adjacent to the upper/lower <i>Base Station RF Bandwidth edge</i> or edge of the <i>sub-block</i>	CW or 1RB interfering signal centre frequency offset from the <i>Base Station RF Bandwidth edge</i> or edge of <i>sub-block</i> inside a gap [kHz]	Type of interfering signal
E-UTRA 1,4 MHz	± 260 (BC1 and BC3) / ± 270 (BC2)	CW
	± 970 (BC1 and BC3) / ± 790 (BC2)	1,4 MHz E-UTRA signal, 1 RB (note 1)
E-UTRA 3 MHz	± 260 (BC1 and BC3) / ± 270 (BC2)	CW
	± 960 (BC1 and BC3) / ± 780 (BC2)	3,0 MHz E-UTRA signal, 1 RB (note 1)
E-UTRA 5 MHz	± 360	CW
	$\pm 1\ 060$	5 MHz E-UTRA signal, 1 RB (note 1)
E-UTRA 10 MHz (note 2)	± 325	CW
	$\pm 1\ 240$	5 MHz E-UTRA signal, 1 RB (note 1)
E-UTRA 15 MHz (note 2)	± 380	CW
	$\pm 1\ 600$	5 MHz E-UTRA signal, 1 RB (note 1)
E-UTRA 20 MHz (note 2)	± 345	CW
	$\pm 1\ 780$	5 MHz E-UTRA signal, 1 RB (note 1)
UTRA FDD	± 345 (BC1 and BC2)	CW
	$\pm 1\ 780$ (BC1 and BC2)	5 MHz E-UTRA signal, 1 RB (note 1)
NR 5 MHz	± 360	CW
	$\pm 1\ 420$	E-UTRA signal, 1 RB (note 1)
NR 10 MHz	± 370	CW
	$\pm 1\ 960$	E-UTRA signal, 1 RB (note 1)
NR 15 MHz (note 2)	± 380	CW
	$\pm 1\ 960$	E-UTRA signal, 1 RB (note 1)
NR 20 MHz (note 2)	± 390	CW
	$\pm 2\ 320$	E-UTRA signal, 1 RB (note 1)
NR 25 MHz (note 2)	± 325	CW
	$\pm 2\ 350$	E-UTRA signal, 1 RB (note 1)
NR 30 MHz (note 2)	± 335	CW
	$\pm 2\ 350$	E-UTRA signal, 1 RB (note 1)
NR 40 MHz (note 2)	± 355	CW
	$\pm 2\ 710$	E-UTRA signal, 1 RB (note 1)
NR 50 MHz (note 2)	± 375	CW
	$\pm 2\ 710$	E-UTRA signal, 1 RB (note 1)
NR 60 MHz (note 2)	± 395	CW
	$\pm 2\ 710$	E-UTRA signal, 1 RB (note 1)
NR 70 MHz (note 2)	± 415	CW
	$\pm 2\ 710$	E-UTRA signal, 1 RB (note 1)
NR 80 MHz (note 2)	± 435	CW
	$\pm 2\ 710$	E-UTRA signal, 1 RB (note 1)
NR 90 MHz (note 2)	± 365	CW
	$\pm 2\ 530$	E-UTRA signal, 1 RB (note 1)
NR 100 MHz (note 2)	± 385	CW
	$\pm 2\ 530$	E-UTRA signal, 1 RB (note 1)

NOTE 1: Interfering signal consisting of one resource block positioned at the stated offset, the *channel bandwidth* of the interfering signal is located adjacently to the *Base Station RF Bandwidth edge*.

NOTE 2: This requirement shall apply only for an E-UTRA FRC A1-3 mapped to the frequency range at the *channel edge* adjacent to the interfering signals.

4.3.22.2.2 Limits for single RAT UTRA operation

The static reference performance as specified in clauses 4.3.24.2.1 and 4.3.25.2.1 shall apply for a Wide Area BS when the signals in table 4.3.22.2.2-1 and table 4.3.22.2.2-2 are at the RIB.

The static reference performance as specified in clauses 4.3.24.2.1 and 4.3.25.2.1 shall apply for a Medium range BS when the signals in table 4.3.22.2.2-3 and table 4.3.22.2.2-4 are at the RIB.

The static reference performance as specified in clauses 4.3.24.2.1 and 4.3.25.2.1 shall apply for a Local Area BS when the signals in table 4.3.22.2.2-5 and table 4.3.22.2.2-6 are at the RIB.

For RIB supporting operation in *non-contiguous spectrum* within each supported *operating band*, the requirement applies in addition inside any *sub-block gap* in case the *sub-block gap* is at least is at least 6,8 MHz. The CW interfering signal offset is defined relative to the lower/upper *sub-block* edge inside the *sub-block gap* and is equal to -1 MHz/+1 MHz, respectively. The GMSK modulated interfering signal offset is defined relative to the lower/upper *sub-block* edge inside the *sub-block gap* and is equal to -3,4 MHz/+3,4 MHz, respectively.

For *multi-band RIBs*, the requirement applies in addition inside any *Inter RF Bandwidth gap*, in case the *Inter RF Bandwidth gap* size is at least 6,8 MHz. The CW interfering signal offset is defined relative to lower/upper *Base Station RF Bandwidth edges* inside the *Inter RF Bandwidth gap* and is equal to -1 MHz/+1 MHz, respectively. The GMSK modulated interfering signal offset is defined relative to lower/upper *Base Station RF Bandwidth edges* inside the *Inter RF Bandwidth gap* and is equal to -3,4 MHz/+3,4 MHz, respectively.

The OTA levels are applied referenced to two antenna gain offsets $\Delta_{OTAREFSENS}$ and $\Delta_{minSENS}$.

Table 4.3.22.2.2-1: Intermodulation requirement (Wide Area BS)

Operating band	Mean power of interfering signals [dBm]	Wanted Signal mean power [dBm] (note)	Offset	Type of Interfering Signal
All bands	$-48 - \Delta_{OTAREFSENS}$	$-115 - \Delta_{OTAREFSENS}$	± 10 MHz	CW signal
	$-48 - \Delta_{minSENS}$	$-115 - \Delta_{minSENS}$		
	$-48 - \Delta_{OTAREFSENS}$	$-115 - \Delta_{OTAREFSENS}$	± 20 MHz	WCDMA signal (note)
	$-48 - \Delta_{minSENS}$	$-115 - \Delta_{minSENS}$		

NOTE: The characteristics of the WCDMA interfering signal are specified in ETSI TS 125 104 [10], annex C.

Table 4.3.22.2.2-2: Narrowband intermodulation requirement (Wide Area BS)

Operating band	Mean power of interfering signals [dBm]	Wanted Signal mean power [dBm] (note)	Offset	Type of Interfering Signal
II, III, IV, V, VIII, X, XII, XIII, XIV, XXV, XXVI	$-47 - \Delta_{OTAREFSENS}$	$-115 - \Delta_{OTAREFSENS}$	$\pm 3,5$ MHz	CW signal
	$-47 - \Delta_{minSENS}$	$-115 - \Delta_{minSENS}$		
	$-47 - \Delta_{OTAREFSENS}$	$-115 - \Delta_{OTAREFSENS}$	$\pm 5,9$ MHz	GMSK modulated (note)
	$-47 - \Delta_{minSENS}$	$-115 - \Delta_{minSENS}$		

NOTE: GMSK as defined in ETSI TS 145 004 [8].

Table 4.3.22.2.2-3: Intermodulation requirement (Medium Range BS)

Operating band	Mean power of interfering signals [dBm]	Wanted Signal mean power [dBm] (note)	Offset	Type of Interfering Signal
All bands	$-44 - \Delta_{OTAREFSENS}$	$-105 - \Delta_{OTAREFSENS}$	± 10 MHz	CW signal
	$-44 - \Delta_{minSENS}$	$-105 - \Delta_{minSENS}$		
	$-44 - \Delta_{OTAREFSENS}$	$-105 - \Delta_{OTAREFSENS}$	± 20 MHz	WCDMA signal (note)
	$-44 - \Delta_{minSENS}$	$-105 - \Delta_{minSENS}$		

NOTE: The characteristics of the WCDMA interfering signal are specified in ETSI TS 125 104 [10], annex C.

Table 4.3.22.2.2-4: Narrowband intermodulation requirement (Medium Range BS)

Operating band	Mean power of interfering signals [dBm]	Wanted Signal mean power [dBm] (note)	Offset	Type of Interfering Signal
II, III, IV, V, VIII, X, XII, XIII, XIV, XXV, XXVI	$-43 - \Delta_{OTAREFSENS}$	$-105 - \Delta_{OTAREFSENS}$	$\pm 3,5$ MHz	CW signal
	$-43 - \Delta_{minSENS}$	$-105 - \Delta_{minSENS}$		
	$-43 - \Delta_{OTAREFSENS}$	$-105 - \Delta_{OTAREFSENS}$	$\pm 5,9$ MHz	GMSK modulated (note)
	$-43 - \Delta_{minSENS}$	$-105 - \Delta_{minSENS}$		

NOTE: GMSK as defined in ETSI TS 145 004 [8].

Table 4.3.22.2-5: Intermodulation requirement (Local Area BS)

Operating band	Mean power of interfering signals [dBm]	Wanted Signal mean power [dBm] (note)	Offset	Type of Interfering Signal
All bands	$-38 - \Delta_{\text{OTAREFSSENS}}$	$-101 - \Delta_{\text{OTAREFSSENS}}$	± 10 MHz	CW signal
	$-38 - \Delta_{\text{minSENS}}$	$-101 - \Delta_{\text{minSENS}}$		
	$-38 - \Delta_{\text{OTAREFSSENS}}$	$-101 - \Delta_{\text{OTAREFSSENS}}$	± 20 MHz	WCDMA signal (note)
	$-38 - \Delta_{\text{minSENS}}$	$-101 - \Delta_{\text{minSENS}}$		

NOTE: The characteristics of the WCDMA interfering signal are specified in ETSI TS 125 104 [10], annex C.

Table 4.3.22.2-6: Narrowband intermodulation requirement (Local Area BS)

Operating band	Mean power of interfering signals [dBm]	Wanted Signal mean power [dBm] (note)	Offset	Type of Interfering Signal
II, III, IV, V, VIII, X, XII, XIII, XIV, XXV, XXVI	$-38 - \Delta_{\text{OTAREFSSENS}}$	$-101 - \Delta_{\text{OTAREFSSENS}}$	$\pm 3,5$ MHz	CW signal
	$-38 - \Delta_{\text{minSENS}}$	$-101 - \Delta_{\text{minSENS}}$		
	$-38 - \Delta_{\text{OTAREFSSENS}}$	$-101 - \Delta_{\text{OTAREFSSENS}}$	$\pm 5,9$ MHz	GMSK modulated (note)
	$-38 - \Delta_{\text{minSENS}}$	$-101 - \Delta_{\text{minSENS}}$		

NOTE GMSK as defined in ETSI TS 145 004 [8].

4.3.22.2.3 Limits for single RAT E-UTRA operation

For E-UTRA, the *throughput* shall be $\geq 95\%$ of the *maximum throughput* of the reference measurement channel, with a wanted signal at the assigned channel frequency and two interfering signals at the RIB, with the conditions specified in tables 4.3.22.2.3-1 and 4.3.22.2.3-2 for intermodulation performance and in tables 4.3.22.2.3-3, 4.3.22.2.3-4 and 4.3.22.2.3-5 for narrowband intermodulation performance. The reference measurement channel for the wanted signal is identified in clause 4.3.25.2.2 for each *channel bandwidth* and *BS class*.

The receiver intermodulation requirement is applicable outside the *Base Station RF Bandwidth* or *Maximum Radio Bandwidth edges*. The interfering signal offset is defined relative to the *Base Station RF Bandwidth edges* or *Maximum Radio Bandwidth edges*.

For RIB supporting operation in *non-contiguous spectrum* within each supported *operating band*, the narrowband intermodulation requirement applies in addition inside any *sub-block gap* in case the *sub-block gap* is at least as wide as the *channel bandwidth* of the E-UTRA interfering signal. The interfering signal offset is defined relative to the *sub-block edges* inside the *sub-block gap*.

For *multi-band RIBs*, the intermodulation requirement applies in addition inside any *Inter RF Bandwidth gap*, in case the gap size is at least as wide as the E-UTRA interfering signal centre frequency offset from the *Base Station RF Bandwidth edge*.

For *multi-band RIBs*, the narrowband intermodulation requirement applies in addition inside any *Inter RF Bandwidth gap*, in case the gap size is at least as wide as the E-UTRA interfering signal in tables 4.3.22.2.3-3, 4.3.22.2.3-4 and 4.3.22.2.3-5. The interfering signal offset is defined relative to the *Base Station RF Bandwidth edges* inside the *Inter RF Bandwidth gap*.

The OTA levels are applied referenced to two antenna gain offsets $\Delta_{\text{OTAREFSSENS}}$ and Δ_{minSENS} .

Table 4.3.22.2.3-1: Intermodulation requirement

BS class	Wanted signal mean power [dBm]	Interfering signal mean power [dBm] (note)	Type of interfering signal
Wide Area BS	$EIS_{REFSENS} + 6 \text{ dB}$	$-52 - \Delta_{OTAREFSSENS}$	See table 4.3.22.2.3-2
	$EIS_{minSENS} + 6 \text{ dB}$	$-52 - \Delta_{minSENS}$	
Medium Range BS	$EIS_{REFSENS} + 6 \text{ dB}$	$-47 - \Delta_{OTAREFSSENS}$	
	$EIS_{minSENS} + 6 \text{ dB}$	$-47 - \Delta_{minSENS}$	
Local Area BS	$EIS_{REFSENS} + 6 \text{ dB}$	$-44 - \Delta_{OTAREFSSENS}$	
	$EIS_{minSENS} + 6 \text{ dB}$	$-44 - \Delta_{minSENS}$	
NOTE: $EIS_{REFSENS}$ and $EIS_{minSENS}$ depend on the RAT, the BS class and on the channel bandwidth, see clauses 4.3.24 and 4.3.25.			

Table 4.3.22.2.3-2: Interfering signal for Intermodulation requirement

E-UTRA channel bandwidth of the lowest/highest carrier received [MHz]	Interfering signal centre frequency offset from the lower/upper Base Station RF Bandwidth edge [MHz]	Type of interfering signal
3	$\pm 4,5$	CW
	$\pm 10,5$	3 MHz E-UTRA signal (note)
5	$\pm 7,5$	CW
	$\pm 17,5$	5 MHz E-UTRA signal
10	$\pm 7,375$	CW
	$\pm 17,5$	5 MHz E-UTRA signal
15	$\pm 7,25$	CW
	$\pm 17,5$	5 MHz E-UTRA signal
20	$\pm 7,125$	CW
	$\pm 17,5$	5 MHz E-UTRA signal
20	$\pm 7,125$	CW
	± 24	20 MHz E-UTRA signal
NOTE: 3 MHz channel bandwidth is not applicable to guard band operation.		

Table 4.3.22.2.3-3: Narrowband intermodulation requirement for Wide Area BS

E-UTRA channel bandwidth of the lowest/highest carrier received [MHz]	Wanted signal mean power [dBm] (note 1)	Interfering signal mean power [dBm]	Interfering RB centre frequency offset from the lower/upper Base Station RF Bandwidth edge or sub-block edge inside a sub-block gap [kHz]	Type of interfering signal
1,4	$EIS_{REFSENS} + 6 \text{ dB}$	$-52 - \Delta_{OTAREFSENS}$	± 270	CW
	$EIS_{minSENS} + 6 \text{ dB}$	$-52 - \Delta_{minSENS}$		
	$EIS_{REFSENS} + 6 \text{ dB}$	$-52 - \Delta_{OTAREFSENS}$	± 790	1,4 MHz E-UTRA signal, 1 RB (note 2)
	$EIS_{minSENS} + 6 \text{ dB}$	$-52 - \Delta_{minSENS}$		
3	$EIS_{REFSENS} + 6 \text{ dB}$	$-52 - \Delta_{OTAREFSENS}$	± 270	CW
	$EIS_{minSENS} + 6 \text{ dB}$	$-52 - \Delta_{minSENS}$		
	$EIS_{REFSENS} + 6 \text{ dB}$	$-52 - \Delta_{OTAREFSENS}$	± 780	3 MHz E-UTRA signal, 1 RB (note 2)
	$EIS_{minSENS} + 6 \text{ dB}$	$-52 - \Delta_{minSENS}$		
5	$EIS_{REFSENS} + 6 \text{ dB}$	$-52 - \Delta_{OTAREFSENS}$	± 360	CW
	$EIS_{minSENS} + 6 \text{ dB}$	$-52 - \Delta_{minSENS}$		
	$EIS_{REFSENS} + 6 \text{ dB}$	$-52 - \Delta_{OTAREFSENS}$	$\pm 1\ 060$	5 MHz E-UTRA signal, 1 RB (note 2)
	$EIS_{minSENS} + 6 \text{ dB}$	$-52 - \Delta_{minSENS}$		
10 (note 3)	$EIS_{REFSENS} + 6 \text{ dB}$	$-52 - \Delta_{OTAREFSENS}$	± 325	CW
	$EIS_{minSENS} + 6 \text{ dB}$	$-52 - \Delta_{minSENS}$		
	$EIS_{REFSENS} + 6 \text{ dB}$	$-52 - \Delta_{OTAREFSENS}$	$\pm 1\ 240$	5 MHz E-UTRA signal, 1 RB (note 2)
	$EIS_{minSENS} + 6 \text{ dB}$	$-52 - \Delta_{minSENS}$		
15 (note 3)	$EIS_{REFSENS} + 6 \text{ dB}$	$-52 - \Delta_{OTAREFSENS}$	± 380	CW
	$EIS_{minSENS} + 6 \text{ dB}$	$-52 - \Delta_{minSENS}$		
	$EIS_{REFSENS} + 6 \text{ dB}$	$-52 - \Delta_{OTAREFSENS}$	$\pm 1\ 600$	5 MHz E-UTRA signal, 1 RB (note 2)
	$EIS_{minSENS} + 6 \text{ dB}$	$-52 - \Delta_{minSENS}$		
20 (note 3)	$EIS_{REFSENS} + 6 \text{ dB}$	$-52 - \Delta_{OTAREFSENS}$	± 345	CW
	$EIS_{minSENS} + 6 \text{ dB}$	$-52 - \Delta_{minSENS}$		
	$EIS_{REFSENS} + 6 \text{ dB}$	$-52 - \Delta_{OTAREFSENS}$	$\pm 1\ 780$	5 MHz E-UTRA signal, 1 RB (note 2)
	$EIS_{minSENS} + 6 \text{ dB}$	$-52 - \Delta_{minSENS}$		
NOTE 1: $EIS_{REFSENS}$ and $EIS_{minSENS}$ depend on the RAT, the BS class and on the channel bandwidth, see clauses 4.3.24 and 4.3.25.				
NOTE 2: Interfering signal consisting of one resource block positioned at the stated offset, the channel bandwidth of the interfering signal is located adjacently to the lower/upper Base Station RF Bandwidth edge.				
NOTE 3: This requirement shall apply only for a FRC A1-3 mapped to the frequency range at the channel edge adjacent to the interfering signals.				

Table 4.3.22.2.3-4: Narrowband intermodulation requirement for Local Area BS

E-UTRA channel bandwidth of the lowest/highest carrier received [MHz]	Wanted signal mean power [dBm] (note 1)	Interfering signal mean power [dBm]	Interfering RB centre frequency offset from the lower/upper Base Station RF Bandwidth edge or sub-block edge inside a sub-block gap [kHz]	Type of interfering signal
1,4	$EIS_{REFSENS} + 6 \text{ dB}$	$-44 - \Delta_{OTAREFSENS}$	± 270	CW
	$EIS_{minSENS} + 6 \text{ dB}$	$-44 - \Delta_{minSENS}$		
	$EIS_{REFSENS} + 6 \text{ dB}$	$-44 - \Delta_{OTAREFSENS}$	± 790	1,4 MHz E-UTRA signal, 1 RB (note 2)
	$EIS_{minSENS} + 6 \text{ dB}$	$-44 - \Delta_{minSENS}$		
3	$EIS_{REFSENS} + 6 \text{ dB}$	$-44 - \Delta_{OTAREFSENS}$	± 270	CW
	$EIS_{minSENS} + 6 \text{ dB}$	$-44 - \Delta_{minSENS}$		
	$EIS_{REFSENS} + 6 \text{ dB}$	$-44 - \Delta_{OTAREFSENS}$	± 780	3 MHz E-UTRA signal, 1 RB (note 2)
	$EIS_{minSENS} + 6 \text{ dB}$	$-44 - \Delta_{minSENS}$		
5	$EIS_{REFSENS} + 6 \text{ dB}$	$-44 - \Delta_{OTAREFSENS}$	± 360	CW
	$EIS_{minSENS} + 6 \text{ dB}$	$-44 - \Delta_{minSENS}$		
	$EIS_{REFSENS} + 6 \text{ dB}$	$-44 - \Delta_{OTAREFSENS}$	$\pm 1\ 060$	5 MHz E-UTRA signal, 1 RB (note 2)
	$EIS_{minSENS} + 6 \text{ dB}$	$-44 - \Delta_{minSENS}$		
10 (note 3)	$EIS_{REFSENS} + 6 \text{ dB}$	$-44 - \Delta_{OTAREFSENS}$	± 325	CW
	$EIS_{minSENS} + 6 \text{ dB}$	$-44 - \Delta_{minSENS}$		
	$EIS_{REFSENS} + 6 \text{ dB}$	$-44 - \Delta_{OTAREFSENS}$	$\pm 1\ 240$	5 MHz E-UTRA signal, 1 RB (note 2)
	$EIS_{minSENS} + 6 \text{ dB}$	$-44 - \Delta_{minSENS}$		
15 (note 3)	$EIS_{REFSENS} + 6 \text{ dB}$	$-44 - \Delta_{OTAREFSENS}$	± 380	CW
	$EIS_{minSENS} + 6 \text{ dB}$	$-44 - \Delta_{minSENS}$		
	$EIS_{REFSENS} + 6 \text{ dB}$	$-44 - \Delta_{OTAREFSENS}$	$\pm 1\ 600$	5 MHz E-UTRA signal, 1 RB (note 2)
	$EIS_{minSENS} + 6 \text{ dB}$	$-44 - \Delta_{minSENS}$		
20 (note 3)	$EIS_{REFSENS} + 6 \text{ dB}$	$-44 - \Delta_{OTAREFSENS}$	± 345	CW
	$EIS_{minSENS} + 6 \text{ dB}$	$-44 - \Delta_{minSENS}$		
	$EIS_{REFSENS} + 6 \text{ dB}$	$-44 - \Delta_{OTAREFSENS}$	$\pm 1\ 780$	5 MHz E-UTRA signal, 1 RB (note 2)
	$EIS_{minSENS} + 6 \text{ dB}$	$-44 - \Delta_{minSENS}$		
NOTE 1: $EIS_{REFSENS}$ and $EIS_{minSENS}$ depend on the RAT, the BS class and on the channel bandwidth, see clauses 4.3.24 and 4.3.25.				
NOTE 2: Interfering signal consisting of one resource block positioned at the stated offset, the channel bandwidth of the interfering signal is located adjacently to the lower/upper Base Station RF Bandwidth edge.				
NOTE 3: This requirement shall apply only for a FRC A1-3 mapped to the frequency range at the channel edge adjacent to the interfering signals.				

Table 4.3.22.2.3-5: Narrowband intermodulation requirement for Medium Range BS

E-UTRA channel bandwidth of the lowest/highest carrier received [MHz]	Wanted signal mean power [dBm] (note 1)	Interfering signal mean power [dBm]	Interfering RB centre frequency offset from the lower/upper Base Station RF Bandwidth edge or sub-block edge inside a sub-block gap [kHz]	Type of interfering signal
1,4	$EIS_{REFSENS} + 6 \text{ dB}$	$-47 - \Delta_{OTAREFSENS}$	± 270	CW
	$EIS_{minSENS} + 6 \text{ dB}$	$-47 - \Delta_{minSENS}$		
	$EIS_{REFSENS} + 6 \text{ dB}$	$-47 - \Delta_{OTAREFSENS}$	± 790	1,4 MHz E-UTRA signal, 1 RB (note 2)
	$EIS_{minSENS} + 6 \text{ dB}$	$-47 - \Delta_{minSENS}$		
3	$EIS_{REFSENS} + 6 \text{ dB}$	$-47 - \Delta_{OTAREFSENS}$	± 270	CW
	$EIS_{minSENS} + 6 \text{ dB}$	$-47 - \Delta_{minSENS}$		
	$EIS_{REFSENS} + 6 \text{ dB}$	$-47 - \Delta_{OTAREFSENS}$	± 780	3 MHz E-UTRA signal, 1 RB (note 2)
	$EIS_{minSENS} + 6 \text{ dB}$	$-47 - \Delta_{minSENS}$		
5	$EIS_{REFSENS} + 6 \text{ dB}$	$-47 - \Delta_{OTAREFSENS}$	± 360	CW
	$EIS_{minSENS} + 6 \text{ dB}$	$-47 - \Delta_{minSENS}$		
	$EIS_{REFSENS} + 6 \text{ dB}$	$-47 - \Delta_{OTAREFSENS}$	$\pm 1\ 060$	5 MHz E-UTRA signal, 1 RB (note 2)
	$EIS_{minSENS} + 6 \text{ dB}$	$-47 - \Delta_{minSENS}$		
10 (note 3)	$EIS_{REFSENS} + 6 \text{ dB}$	$-47 - \Delta_{OTAREFSENS}$	± 325	CW
	$EIS_{minSENS} + 6 \text{ dB}$	$-47 - \Delta_{minSENS}$		
	$EIS_{REFSENS} + 6 \text{ dB}$	$-47 - \Delta_{OTAREFSENS}$	$\pm 1\ 240$	5 MHz E-UTRA signal, 1 RB (note 2)
	$EIS_{minSENS} + 6 \text{ dB}$	$-47 - \Delta_{minSENS}$		
15 (note 3)	$EIS_{REFSENS} + 6 \text{ dB}$	$-47 - \Delta_{OTAREFSENS}$	± 380	CW
	$EIS_{minSENS} + 6 \text{ dB}$	$-47 - \Delta_{minSENS}$		
	$EIS_{REFSENS} + 6 \text{ dB}$	$-47 - \Delta_{OTAREFSENS}$	$\pm 1\ 600$	5 MHz E-UTRA signal, 1 RB (note 2)
	$EIS_{minSENS} + 6 \text{ dB}$	$-47 - \Delta_{minSENS}$		
20 (note 3)	$EIS_{REFSENS} + 6 \text{ dB}$	$-47 - \Delta_{OTAREFSENS}$	± 345	CW
	$EIS_{minSENS} + 6 \text{ dB}$	$-47 - \Delta_{minSENS}$		
	$EIS_{REFSENS} + 6 \text{ dB}$	$-47 - \Delta_{OTAREFSENS}$	$\pm 1\ 780$	5 MHz E-UTRA signal, 1 RB (note 2)
	$EIS_{minSENS} + 6 \text{ dB}$	$-47 - \Delta_{minSENS}$		
NOTE 1: $EIS_{REFSENS}$ and $EIS_{minSENS}$ depend on the RAT, the BS class and on the channel bandwidth, see clauses 4.3.24 and 4.3.25.				
NOTE 2: Interfering signal consisting of one resource block positioned at the stated offset, the channel bandwidth of the interfering signal is located adjacently to the lower/upper Base Station RF Bandwidth edge.				
NOTE 3: This requirement shall apply only for a FRC A1-3 mapped to the frequency range at the channel edge adjacent to the interfering signals.				

4.3.22.3 Conformance

The conformance tests for this requirement shall be as defined in clause 5.3.22 of the present document.

4.3.23 OTA Adjacent Channel Selectivity (OTA ACS), general blocking and narrowband blocking

4.3.23.1 Definition and applicability

The Adjacent Channel Selectivity (ACS), general blocking and narrowband blocking characteristics are measures of the receiver unit ability to receive a wanted signal at its assigned channel in the presence of an unwanted interferer inside the operating band.

The requirement applies at the RIB when the AoA of the incident wave of a received signal and the interfering signal are from the same direction, and:

- when the wanted signal is based on $EIS_{REFSENS}$: the AoA of the incident wave of a received signal and the interfering signal are within the *OTA REFSENS RoAoA*;

- when the wanted signal is based on $EIS_{minSENS}$: the AoA of the incident wave of a received signal and the interfering signal are within the *minSENS RoAoA*.

The wanted and interfering signals apply to each supported polarization, under the assumption of *polarization match*.

NOTE: For Single RAT requirements, the in-band selectivity characteristics is referred to as "adjacent channel selectivity", whereas for the MSR requirements, the corresponding property is referred to as "general blocking" since the adjacent frequency range may not carry a channel addressable from the interfered carrier. The in-band blocking requirement applies from $F_{UL_low} - \Delta f_{OOB}$ to $F_{UL_high} + \Delta f_{OOB}$, excluding the downlink frequency range of the *operating band*. The Δf_{OOB} is defined in table 4.3.23.1-1.

Table 4.3.23.1-1: Δf_{OOB} offset for operating bands

Operating band characteristics	Δf_{OOB} [MHz]
$F_{UL_high} - F_{UL_low} < 100$ MHz	20
$100 \text{ MHz} \leq F_{UL_high} - F_{UL_low} \leq 900$ MHz	60

4.3.23.2 Limits

4.3.23.2.1 Limits for *MSR operation*

4.3.23.2.1.1 General blocking

For the general blocking requirement, the interfering signal shall be a UTRA FDD signal as specified in clause A.1 in ETSI TS 125 141 [7] for a UTRA, E-UTRA or NR (≤ 20 MHz) wanted signal. The interfering signal shall be a 20 MHz E-UTRA signal for NR wanted signal *channel bandwidth* more than 20 MHz.

For RIBs supporting operation in *non-contiguous spectrum*, the requirement applies in addition inside any *sub-block gap*, in case the *sub-block gap* size is at least 15 MHz. The interfering signal offset is defined relative to the *sub-block* edges inside the *sub-block gap*.

For *multi-band RIBs* the requirement applies in addition inside any *Inter RF Bandwidth gap*, in case the gap size is at least 15 MHz. The interfering signal offset is defined relative to the *Base Station RF Bandwidth edges* inside the *Inter RF Bandwidth gap*.

For the wanted and interfering signal coupled to the *RIB*, using the parameters in table 4.3.23.2.1.1-1, the following requirements shall apply:

- For any UTRA FDD carrier, the BER shall not exceed 0,001 for the reference measurement channel specified in clause 4.3.25.2.1.
- For any E-UTRA carrier, the *throughput* shall be ≥ 95 % of the *maximum throughput* of the reference measurement channel specified in clause 4.3.25.2.2.
- For any NR carrier, the *throughput* shall be ≥ 95 % of the *maximum throughput* of the reference measurement channel specified in clause 4.3.25.2.3.

For *multi-band RIBs*, the requirement applies according to table 4.3.23.2.1.1-1 for the in-band blocking frequency ranges of each supported *operating band*.

Table 4.3.23.2.1.1-1: General blocking requirement

Base Station Type	Mean power of interfering signal [dBm]	Wanted Signal mean power [dBm] (note 1)	Centre Frequency of Interfering Signal	Interfering signal centre frequency minimum frequency offset from the <i>Base Station RF Bandwidth edge or edge of sub-block inside a gap</i> [MHz]
Wide Area BS	$-40 + y - \Delta_{\text{OTAREFSSENS}}$ (notes 7 and 9)	$EIS_{\text{REFSENS}} + x$ dB (notes 2, 5 and 9)	$F_{\text{UL_low}} - \Delta f_{\text{OOB}}$ $F_{\text{UL_high}} + \Delta f_{\text{OOB}}$	$(\pm 7,5+z)$ (note 11)
	$-40 + y - \Delta_{\text{minSENS}}$ (notes 7 and 10)	$EIS_{\text{minSENS}} + x$ dB (notes 2, 5 and 10)		
Medium Range BS	$-35 + y - \Delta_{\text{OTAREFSSENS}}$ (notes 7 and 9)	$EIS_{\text{REFSENS}} + x$ dB (notes 3, 5 and 9)		
	$-35 + y - \Delta_{\text{minSENS}}$ (notes 7 and 10)	$EIS_{\text{minSENS}} + x$ dB (notes 3, 5 and 10)		
Local Area BS	$-30 + y - \Delta_{\text{OTAREFSSENS}}$ (notes 7 and 9)	$EIS_{\text{REFSENS}} + x$ dB (notes 4, 5 and 9)		
	$-30 + y - \Delta_{\text{minSENS}}$ (notes 7 and 10)	$EIS_{\text{minSENS}} + x$ dB (notes 4, 5 and 10)		
<p>NOTE 1: EIS_{REFSENS} and EIS_{minSENS} depend on the RAT, the <i>BS class</i> and on the <i>channel bandwidth</i>, see clauses 4.3.24 and 4.3.25.</p> <p>NOTE 2: For <i>Wide Area BS</i> that does not support NR, "x" is equal to 6 in case of E-UTRA or UTRA wanted signals.</p> <p>NOTE 3: For <i>Medium Range BS</i> that does not support NR, "x" is equal to 6 in case of UTRA wanted signals, 9 in case of E-UTRA wanted signal.</p> <p>NOTE 4: For <i>Local Area BS</i> that does not support NR, "x" is equal to 11 in case of E-UTRA wanted signal, 6 in case of UTRA wanted signal.</p> <p>NOTE 5: For a BS that supports NR but does not support UTRA, x is equal to 6.</p> <p>NOTE 6: For a BS capable of multi-band operation, "x" in Notes 2, 3, 4 and 5 applies in case of interfering signals that are in the in-band blocking frequency range of the <i>operating band</i> where the wanted signal is present or in the in-band blocking frequency range of an adjacent or overlapping operating band. For other in-band blocking frequency ranges of the interfering signal for the supported <i>operating bands</i>, "x" is equal to 1,4 dB.</p> <p>NOTE 7: For a BS that not supporting NR, "y" is equal to zero for all <i>BS classes</i>. For a BS that supports NR but does not support UTRA, "y" is equal to -3 for the <i>Wide Area BS</i> and <i>Medium Range BS</i> and -5 for the <i>Local Area BS</i>.</p> <p>NOTE 8: The downlink frequency range of an FDD <i>operating band</i> is excluded from the general blocking requirement.</p> <p>NOTE 9: This limit is only applied in the OTA REFSSENS conformance test directions.</p> <p>NOTE 10: This limit is only applied in the OTA minSENS <i>receiver target reference direction</i>.</p> <p>NOTE 11: For NR wanted signal <i>channel bandwidth</i> more than 20 MHz, $z = 22,5$ MHz. For all other cases, $z = 0$ MHz.</p>				

4.3.23.2.1.2 General narrowband blocking

For the narrowband blocking requirement, the interfering signal shall be an E-UTRA 1RB signal as specified in clause A.3 in ETSI TS 137 141 [6].

The requirement is applicable outside the *Base Station RF Bandwidth* or *Maximum Radio Bandwidth*. The interfering signal offset is defined relative to the *Base Station RF Bandwidth edges* or *Maximum Radio Bandwidth edges*.

For RIBs supporting operation in *non-contiguous spectrum*, the requirement applies in addition inside any *sub-block gap*, in case the *sub-block gap* size is at least 3 MHz. The interfering signal offset is defined relative to the *sub-block edges* inside the *sub-block gap*.

For *multi-band RIBs*, the requirement applies in addition inside any *Inter RF Bandwidth gap* in case the gap size is at least 3 MHz. The interfering signal offset is defined relative to the *Base Station RF Bandwidth edges* inside the *Inter RF Bandwidth gap*.

For the wanted and interfering signal coupled to the RIB, using the parameters in table 4.3.23.2.2-1 the following requirements shall apply:

- For any UTRA FDD carrier, the BER shall not exceed 0,001 for the reference measurement channel specified in clause 4.3.25.2.1.
- For any E-UTRA carrier, the *throughput* shall be ≥ 95 % of the *maximum throughput* of the reference measurement channel specified in clause 4.3.25.2.2.
- For any NR carrier, the *throughput* shall be ≥ 95 % of the *maximum throughput* of the reference measurement channel specified in clause 4.3.25.2.3.

Table 4.3.23.2.1.2-1: Narrowband blocking requirement

Base Station Type	RAT of the carrier	Wanted signal mean power [dBm] (notes 1, 2 and 8)	Interfering signal mean power [dBm]	Interfering RB (note 3) centre frequency offset from the AAS Base Station RF Bandwidth edge or edge of sub-block inside a gap [kHz]	
Wide Area BS	E-UTRA, NR, UTRA	$EIS_{REFSENS} + x$ dB (note 6)	$-49 - \Delta_{OTAREFSENS}$ (note 6)	$\pm(240 + m \cdot 180)$, $m=0, 1, 2, 3, 4, 9, 14$ (note 4)	
Medium Range BS		$EIS_{minSENS} + x$ dB (note 7)	$-49 - \Delta_{minSENS}$ (note 7)		
		$EIS_{REFSENS} + x$ dB (note 6)	$-44 - \Delta_{OTAREFSENS}$ (note 6)		
Local Area BS		$EIS_{minSENS} + x$ dB (note 7)	$-44 - \Delta_{minSENS}$ (note 7)		$\pm(550 + m \cdot 180)$, $m=0, 1, 2, 3, 4, 29, 54, 79, 99$ (note 5)
		$EIS_{REFSENS} + x$ dB (note 6)	$-41 - \Delta_{OTAREFSENS}$ (note 6)		
		$EIS_{minSENS} + x$ dB (note 7)	$-41 - \Delta_{minSENS}$ (note 7)		
<p>NOTE 1: $EIS_{REFSENS}$ and $EIS_{minSENS}$ depend on the RAT, the BS class and on the channel bandwidth, see clauses 4.3.24 and 4.3.25.</p> <p>NOTE 2: "x" is equal to 6 dB in case of E-UTRA or UTRA wanted signals.</p> <p>NOTE 3: Interfering signal (E-UTRA 3 MHz) consisting of one resource block positioned at the stated offset, the channel bandwidth of the interfering signal is located adjacently to the AAS Base Station RF Bandwidth edge.</p> <p>NOTE 4: Applicable for channel bandwidths equal to or below 20 MHz.</p> <p>NOTE 5: Applicable for channel bandwidths above 20 MHz.</p> <p>NOTE 6: This limit is only applied in the OTA REFSSENS conformance test directions.</p> <p>NOTE 7: This limit is only applied in the OTA minSENS receiver target reference direction.</p> <p>NOTE 8: 7,5 kHz shift is not applied to the wanted signal of NR.</p>					

4.3.23.2.2 Limits for Single RAT UTRA FDD operation

For each measured carrier, the BER shall not exceed 0,001 for the parameters specified in table 4.3.23.2.2-1.

For multi-carrier RIB the ACS requirement is applicable outside the Base Station RF Bandwidth or Maximum Radio Bandwidth. The interfering signal offset is defined relative to the lower/upper Base Station RF Bandwidth edges or Maximum Radio Bandwidth edges.

For RIBs supporting operation in non-contiguous spectrum within any operating band, the requirement applies in addition inside any sub-block gap, in case the sub-block gap size is at least 5 MHz. The interfering signal offset is defined relative to the lower/upper sub-block edge inside the sub-block gap and is equal to -2,5 MHz/+2,5 MHz, respectively.

For a multi-band RIBs, the requirement applies in addition inside any Inter RF Bandwidth gap, in case the Inter RF Bandwidth gap size is at least 5 MHz. The interfering signal offset is defined relative to lower/upper Base Station RF Bandwidth edges inside the Inter RF Bandwidth gap and is equal to -2,5 MHz/+2,5 MHz, respectively.

Table 4.3.23.2.2-1: Adjacent channel selectivity

Parameter	Level Wide Area BS	Level Medium Range BS	Level Local Area BS	Unit
Data rate	12,2	12,2	12,2	kbps
Wanted signal mean power	-115 - $\Delta_{\min\text{SENS}}$	-105 - $\Delta_{\min\text{SENS}}$	-101 - $\Delta_{\min\text{SENS}}$	dBm
Interfering signal mean power	-52 - $\Delta_{\min\text{SENS}}$	-42 - $\Delta_{\min\text{SENS}}$	-38 - $\Delta_{\min\text{SENS}}$	dBm
F_{uw} offset (Modulated)	± 5	± 5	± 5	MHz

4.3.23.2.3 Limits for single RAT E-UTRA operation

The *throughput* shall be ≥ 95 % of the *maximum throughput* of the reference measurement channel.

For E-UTRA Wide Area BS, the wanted and the interfering signal coupled to the BS antenna input are specified in tables 4.3.23.2.3-1 and 4.3.23.2.3-2 for narrowband blocking and 4.3.23.2.3-3 for ACS. The reference measurement channel for the wanted signal is identified in table 4.3.25.2.2-1 for each *channel bandwidth*.

For E-UTRA Medium Range BS, the wanted and the interfering signal coupled to the BS antenna input are specified in tables 4.3.23.2.3-1 and 4.3.23.2.3-2 for narrowband blocking and in table 4.3.23.2.3-4 for ACS. The reference measurement channel for the wanted signal is identified in table 4.3.25.2.2-2 for each *channel bandwidth*.

For E-UTRA Local Area BS, the wanted and the interfering signal coupled to the BS antenna input are specified in tables 4.3.23.4-1 and 4.3.23.4-2 for narrowband blocking and 4.3.23.4-5 for ACS. The reference measurement channel for the wanted signal is identified in table 4.3.25.2.2-3 for each *channel bandwidth*.

For narrowband blocking the OTA levels are applied referenced to 2 antenna gain offsets $\Delta_{\text{OTAREFSENS}}$ and $\Delta_{\min\text{SENS}}$.

For ACS the OTA levels are applied referenced to $\Delta_{\min\text{SENS}}$.

The ACS and narrowband blocking requirement is applicable outside the *Base Station RF Bandwidth* or *Maximum Radio Bandwidth*. The interfering signal offset is defined relative to the *Base station RF Bandwidth edges* or *Maximum Radio Bandwidth edges*.

For RIBs supporting operation in *non-contiguous spectrum* within any *operating band*, the ACS requirement applies in addition inside any *sub-block gap*, in case the *sub-block gap* size is at least as wide as the E-UTRA interfering signal in tables 4.3.23.2.3-3, 4.3.23.2.3-4 and 4.3.23.2.3-5. The interfering signal offset is defined relative to the *sub-block edges* inside the *sub-block gap*.

For *multi-band RIBs*, the ACS requirement applies in addition inside any *Inter RF Bandwidth gap* at the RIB, in case the gap size is at least as wide as the E-UTRA interfering signal in tables 4.3.23.2.3-3, 4.3.23.2.3-4 and 4.3.23.2.3-5. The interfering signal offset is defined relative to the *Base Station RF Bandwidth edges* inside the *Inter RF Bandwidth gap*.

For a RIBs operating in *non-contiguous spectrum* within any *operating band*, the narrowband blocking requirement applies in addition inside any *sub-block gap*, in case the *sub-block gap* size is at least as wide as the *channel bandwidth* of the E-UTRA interfering signal in table 4.3.23.2.3-2. The interfering signal offset is defined relative to the *sub-block edges* inside the *sub-block gap*.

For *multi-band RIBs*, the narrowband blocking requirement applies in addition inside any *Inter RF Bandwidth gap*, in case the *Inter RF Bandwidth gap* size is at least as wide as the E-UTRA interfering signal in table 4.3.23.2.3-2. The interfering signal offset is defined relative to the *Base Station RF Bandwidth edges* inside the *Inter RF Bandwidth gap*.

Table 4.3.23.2.3-1: Narrowband blocking requirement

Base Station Type	Wanted signal mean power [dBm] (note 1)	Interfering signal mean power [dBm]	Type of interfering signal
Wide Area BS	$EIS_{REFSENS} + 6 \text{ dB}$ (note 2)	$-49 - \Delta_{OTAREFSSENS}$ (note 2)	See table 4.3.23.2.3-2
	$EIS_{minSENS} + 6 \text{ dB}$ (note 3)	$-49 - \Delta_{minSENS}$ (note 3)	
Medium Range BS	$EIS_{REFSENS} + 6 \text{ dB}$ (note 2)	$-44 - \Delta_{OTAREFSSENS}$ (note 2)	See table 4.3.23.2.3-2
	$EIS_{minSENS} + 6 \text{ dB}$ (note 3)	$-44 - \Delta_{minSENS}$ (note 3)	
Local Area BS	$EIS_{REFSENS} + 6 \text{ dB}$ (note 2)	$-41 - \Delta_{OTAREFSSENS}$ (note 2)	See table 4.3.23.2.3-2
	$EIS_{minSENS} + 6 \text{ dB}$ (note 3)	$-41 - \Delta_{minSENS}$ (note 3)	

NOTE 1: $EIS_{REFSENS}$ and $EIS_{minSENS}$ depend on the RAT, the BS class and on the channel bandwidth, see clauses 4.3.24 and 4.3.25.
NOTE 2: This limit is only applied in the OTA REFSSENS conformance test directions.
NOTE 3: This limit is only applied in the OTA minSENS receiver target reference direction.

Table 4.3.23.2.3-2: Interfering signal for Narrowband blocking requirement

E-UTRA channel BW of the lowest/highest carrier received [MHz]	Interfering RB centre frequency offset to the lower/upper Base Station RF Bandwidth edge or sub-block edge inside a sub-block gap [kHz]	Type of interfering signal
1,4	$\pm(252,5+m \times 180)$, m=0, 1, 2, 3, 4, 5	1,4 MHz E-UTRA signal, 1 RB
3	$\pm(247,5+m \times 180)$, m=0, 1, 2, 3, 4, 7, 10, 13	3 MHz E-UTRA signal, 1 RB
5	$\pm(342,5+m \times 180)$, m=0, 1, 2, 3, 4, 9, 14, 19, 24	5 MHz E-UTRA signal, 1 RB
10	$\pm(347,5+m \times 180)$, m=0, 1, 2, 3, 4, 9, 14, 19, 24	5 MHz E-UTRA signal, 1 RB
15	$\pm(352,5+m \times 180)$, m=0, 1, 2, 3, 4, 9, 14, 19, 24	5 MHz E-UTRA signal, 1 RB
20	$\pm(342,5+m \times 180)$, m=0, 1, 2, 3, 4, 9, 14, 19, 24	5 MHz E-UTRA signal, 1 RB

NOTE: Interfering signal consisting of one resource block is positioned at the stated offset, the channel bandwidth of the interfering signal is located adjacently to the lower/upper Base Station RF Bandwidth edge.

Table 4.3.23.2.3-3: Adjacent channel selectivity for Wide Area BS

E-UTRA channel bandwidth of the lowest/highest carrier received [MHz]	Wanted signal mean power [dBm] (note)	Interfering signal mean power [dBm]	Interfering signal centre frequency offset from the lower/upper Base Station RF Bandwidth edge or sub-block edge inside a sub-block gap [MHz]	Type of interfering signal
1,4	$EIS_{minSENS} + 11 \text{ dB}$	$-52 - \Delta_{minSENS}$	$\pm 0,7025$	1,4 MHz E-UTRA signal
3	$EIS_{minSENS} + 8 \text{ dB}$	$-52 - \Delta_{minSENS}$	$\pm 1,5075$	3 MHz E-UTRA signal
5	$EIS_{minSENS} + 6 \text{ dB}$	$-52 - \Delta_{minSENS}$	$\pm 2,5025$	5 MHz E-UTRA signal
10	$EIS_{minSENS} + 6 \text{ dB}$	$-52 - \Delta_{minSENS}$	$\pm 2,5075$	5 MHz E-UTRA signal
15	$EIS_{minSENS} + 6 \text{ dB}$	$-52 - \Delta_{minSENS}$	$\pm 2,5125$	5 MHz E-UTRA signal
20	$EIS_{minSENS} + 6 \text{ dB}$	$-52 - \Delta_{minSENS}$	$\pm 2,5025$	5 MHz E-UTRA signal

NOTE: $EIS_{minSENS}$ depends on the channel bandwidth as specified see clause 4.3.24.

Table 4.3.23.2.3-4: Adjacent channel selectivity for Medium Range BS

E-UTRA channel bandwidth of the lowest/highest carrier received [MHz]	Wanted signal mean power [dBm] (note)	Interfering signal mean power [dBm]	Interfering signal centre frequency offset to the lower/upper Base Station RF Bandwidth edge or sub-block edge inside a sub-block gap [MHz]	Type of interfering signal
1,4	$EIS_{\min SENS} + 11 \text{ dB}$	$-47 - \Delta_{\min SENS}$	$\pm 0,7025$	1,4 MHz E-UTRA signal
3	$EIS_{\min SENS} + 8 \text{ dB}$	$-47 - \Delta_{\min SENS}$	$\pm 1,5075$	3 MHz E-UTRA signal
5	$EIS_{\min SENS} + 6 \text{ dB}$	$-47 - \Delta_{\min SENS}$	$\pm 2,5025$	5 MHz E-UTRA signal
10	$EIS_{\min SENS} + 6 \text{ dB}$	$-47 - \Delta_{\min SENS}$	$\pm 2,5075$ $\pm 10,0175$	5 MHz E-UTRA signal 20 MHz E-UTRA signal
15	$EIS_{\min SENS} + 6 \text{ dB}$	$-47 - \Delta_{\min SENS}$	$\pm 2,5125$	5 MHz E-UTRA signal
20	$EIS_{\min SENS} + 6 \text{ dB}$	$-47 - \Delta_{\min SENS}$	$\pm 2,5025$ $\pm 10,0175$	5 MHz E-UTRA signal 20 MHz E-UTRA signal

NOTE: $EIS_{\min SENS}$ depends on the *channel bandwidth* as specified see clause 4.3.24.

Table 4.3.23.2.3-5: Adjacent channel selectivity for Local Area BS

E-UTRA channel bandwidth of the lowest/highest carrier received [MHz]	Wanted signal mean power [dBm] (note)	Interfering signal mean power [dBm]	Interfering signal centre frequency offset from the lower/upper Base Station RF Bandwidth edge or sub-block edge inside a sub-block gap [MHz]	Type of interfering signal
1,4	$EIS_{\min SENS} + 11 \text{ dB}$	$-44 - \Delta_{\min SENS}$	$\pm 0,7025$	1,4 MHz E-UTRA signal
3	$EIS_{\min SENS} + 8 \text{ dB}$	$-44 - \Delta_{\min SENS}$	$\pm 1,5075$	3 MHz E-UTRA signal
5	$EIS_{\min SENS} + 6 \text{ dB}$	$-44 - \Delta_{\min SENS}$	$\pm 2,5025$	5 MHz E-UTRA signal
10	$EIS_{\min SENS} + 6 \text{ dB}$	$-44 - \Delta_{\min SENS}$	$\pm 2,5075$ $\pm 10,0175$	5 MHz E-UTRA signal 20 MHz E-UTRA signal
15	$EIS_{\min SENS} + 6 \text{ dB}$	$-44 - \Delta_{\min SENS}$	$\pm 2,5125$	5 MHz E-UTRA signal
20	$EIS_{\min SENS} + 6 \text{ dB}$	$-44 - \Delta_{\min SENS}$	$\pm 2,5025$ $\pm 10,0175$	5 MHz E-UTRA signal 20 MHz E-UTRA signal

NOTE: $EIS_{\min SENS}$ depends on the *channel bandwidth* as specified see clause 4.3.24.

4.3.23.3 Conformance

The conformance tests for this requirement shall be as defined in clause 5.3.23 of the present document.

4.3.24 OTA Sensitivity

4.3.24.1 Definition and applicability

The OTA sensitivity requirement is based upon the minimum EIS (D10.6) and OSDD, which are describing the intended AAS BS receiver beam performance under normal operation.

NOTE: $EIS_{\min SENS}$ is the lowest EIS value for all the OSDD's, while its related range of angles of arrival is called *minSENS RoAoA*.

The minimum EIS level shall apply to each supported polarization, under the assumption of *polarization match*.

4.3.24.2 Limits

4.3.24.2.1 Limits for UTRA operation

For each UTRA carrier, the BER shall not exceed 0,001 with the parameters specified in table 4.3.24.2.1-1.

Reference measurement channel is defined in ETSI TS 125 141 [7], annex A (PN-9 data sequence or longer).

Table 4.3.24.2.1-1: UTRA OTA sensitivity parameters

Reference measurement channel	Reference measurement channel data rate	OTA sensitivity (dBm)	
		$f \leq 3,0$ GHz	$3,0$ GHz $< f \leq 4,2$ GHz
12,2 kbps DPCH	12,2 kbps	Minimum EIS (D10.6) + 1,3 dB	Minimum EIS (D10.6) + 1,4 dB

4.3.24.2.2 Limits for E-UTRA operation

For each E-UTRA carrier, the *throughput* shall be ≥ 95 % of the *maximum throughput* of the reference measurement channel with parameters specified in table 4.3.24.2.2-1.

Reference measurement channels are defined in ETSI TS 136 141 [11], clause A.1.

Table 4.3.24.2.2-1: E-UTRA OTA sensitivity parameters

E-UTRA channel bandwidth (MHz)	Reference measurement channel	OTA sensitivity (dBm)	
		$f \leq 3,0$ GHz	$3,0$ GHz $< f \leq 4,2$ GHz
1,4	FRC A1-1	Minimum EIS (D10.6) + 1,3 dB	Minimum EIS (D10.6) + 1,4 dB
3	FRC A1-2		
5	FRC A1-3		
10	FRC A1-3 (note)		
15			
20			

NOTE: EIS is the power level of a single instance of the reference measurement channel. This requirement shall be met for each consecutive application of a single instance of FRC A1-3 in ETSI TS 136 141 [11] mapped to disjoint frequency ranges with a width of 25 Resource Blocks each.

4.3.24.2.3 Limits for NR operation

For each NR carrier, the *throughput* shall be ≥ 95 % of the *maximum throughput* of the reference measurement channel with parameters specified in table 4.3.24.2.3-1.

Reference measurement channels are defined in ETSI TS 138 141-2 [15], clause A.1.

Table 4.3.24.2.3-1: NR OTA sensitivity parameters

BS channel bandwidth [MHz]	Sub-carrier spacing [kHz]	Reference measurement channel	EIS level (dBm)	
			$f \leq 3,0$ GHz	$3,0$ GHz $< f \leq 4,2$ GHz
5, 10, 15, 25, 30	15	G-FR1-A1-1	Minimum EIS (D10.6) + 1,3 dB	Minimum EIS (D10.6) + 1,4 dB
5, 10, 15, 25, 30	30	G-FR1-A1-2		
10, 15, 25, 30	60	G-FR1-A1-3		
20, 40, 50, 60, 70, 80, 90, 100	15	G-FR1-A1-4		
20, 40, 50, 60, 70, 80, 90, 100	30	G-FR1-A1-5		
20, 40, 50, 60, 70, 80, 90, 100	60	G-FR1-A1-6		

4.3.24.3 Conformance

The conformance tests for this requirement shall be as defined in clause 5.3.24 of the present document.

4.3.25 OTA Reference sensitivity level

4.3.25.1 Definition and applicability

The OTA reference sensitivity requirement is based upon assumptions of a minimum antenna array gain over *OTA REFSENS RoAoA*, describing the intended *AAS BS receiver* performance under normal operation.

The OTA reference sensitivity requirement is intended to ensure the OTA reference sensitivity level for a declared *OTA REFSENS RoAoA*.

The OTA reference sensitivity power level $EIS_{REFSENS}$ is the mean power received at the RIB at which a reference performance requirement shall be met for a specified reference measurement channel.

The OTA reference sensitivity requirement shall apply to each supported polarization, under the assumption of *polarization match*.

4.3.25.2 Limits

4.3.25.2.1 Limits for UTRA FDD operation

For each UTRA carrier, the BER shall not exceed 0,001 with parameters specified in table 4.3.25.2.1-1.

Reference measurement channel is defined in annex A in ETSI TS 125 141 [7] (PN-9 data sequence or longer).

Table 4.3.25.2.1-1: UTRA OTA reference sensitivity parameters

Base Station Type	Reference measurement channel	Reference measurement channel data rate	$EIS_{REFSENS}$ (dBm)	
			$f \leq 3,0$ GHz	$3,0$ GHz $< f \leq 4,2$ GHz
Wide Area BS	12,2 kbps DPCH	12,2 kbps	-119,7 - $\Delta_{OTAREFSNS}$	-119,6 - $\Delta_{OTAREFSNS}$
Medium Range BS	12,2 kbps DPCH	12,2 kbps	-109,7 - $\Delta_{OTAREFSNS}$	-109,6 - $\Delta_{OTAREFSNS}$
Local Area BS	12,2 kbps DPCH	12,2 kbps	-105,7 - $\Delta_{OTAREFSNS}$	-105,6 - $\Delta_{OTAREFSNS}$

4.3.25.2.2 Limits for E-UTRA operation

For each E-UTRA carrier, the *throughput* shall be ≥ 95 % of the *maximum throughput* of the reference measurement channel with parameters specified in tables 4.3.25.2.2-1 to 4.3.25.2.2-3.

Reference measurement channels are specified in ETSI TS 136 141 [11], clause A.1.

Table 4.3.25.2.2-1: E-UTRA Wide area BS OTA reference sensitivity parameters

E-UTRA channel bandwidth (MHz)	Reference measurement channel	$EIS_{REFSENS}$ (dBm)	
		$f \leq 3,0$ GHz	$3,0$ GHz $< f \leq 4,2$ GHz
1,4	FRC A1-1	-105,5 - $\Delta_{OTAREFSNS}$	-105,4 - $\Delta_{OTAREFSNS}$
3	FRC A1-2	-101,7 - $\Delta_{OTAREFSNS}$	-101,6 - $\Delta_{OTAREFSNS}$
5	FRC A1-3	-100,2 - $\Delta_{OTAREFSNS}$	-100,1 - $\Delta_{OTAREFSNS}$
10	FRC A1-3 (note)	-100,2 - $\Delta_{OTAREFSNS}$	-100,1 - $\Delta_{OTAREFSNS}$
15			
20			
NOTE: $EIS_{REFSENS}$ is the power level of a single instance of the reference measurement channel. This requirement shall be met for each consecutive application of a single instance of FRC A1-3 mapped to disjoint frequency ranges with a width of 25 Resource Blocks each.			

Table 4.3.25.2.2-2: E-UTRA Medium range BS OTA reference sensitivity parameters

E-UTRA channel bandwidth (MHz)	Reference measurement channel	EIS _{REFSENS} (dBm)	
		f ≤ 3,0 GHz	3,0 GHz < f ≤ 4,2 GHz
1,4	FRC A1-1	-100,5 - Δ _{OTAREFSSENS}	-100,4 - Δ _{OTAREFSSENS}
3	FRC A1-2	-96,7 - Δ _{OTAREFSSENS}	-96,6 - Δ _{OTAREFSSENS}
5	FRC A1-3	-95,2 - Δ _{OTAREFSSENS}	-95,1 - Δ _{OTAREFSSENS}
10	FRC A1-3 (note)	-95,2 - Δ _{OTAREFSSENS}	-95,1 - Δ _{OTAREFSSENS}
15			
20			
NOTE: EIS _{REFSENS} is the power level of a single instance of the reference measurement channel. This requirement shall be met for each consecutive application of a single instance of FRC A1-3, mapped to disjoint frequency ranges with a width of 25 Resource Blocks each.			

Table 4.3.25.2.2-3: E-UTRA Local area BS OTA reference sensitivity parameters

E-UTRA channel bandwidth (MHz)	Reference measurement channel	EIS _{REFSENS} (dBm)	
		f ≤ 3,0 GHz	3,0 GHz < f ≤ 4,2 GHz
1,4	FRC A1-1	-97,5 - Δ _{OTAREFSSENS}	-97,4 - Δ _{OTAREFSSENS}
3	FRC A1-2	-93,7 - Δ _{OTAREFSSENS}	-93,6 - Δ _{OTAREFSSENS}
5	FRC A1-3	-92,2 - Δ _{OTAREFSSENS}	-92,1 - Δ _{OTAREFSSENS}
10	FRC A1-3 (note)	-92,2 - Δ _{OTAREFSSENS}	-92,1 - Δ _{OTAREFSSENS}
15			
20			
NOTE: EIS _{REFSENS} is the power level of a single instance of the reference measurement channel. This requirement shall be met for each consecutive application of a single instance of FRC A1-3, mapped to disjoint frequency ranges with a width of 25 Resource Blocks each.			

4.3.25.2.3 Limits for NR operation

For each measured NR carrier, the *throughput* shall be ≥ 95 % of the *maximum throughput* of the reference measurement channel with parameters specified in tables 4.3.25.2.3-1 to 4.3.25.2.3-3.

Reference measurement channels are specified in ETSI TS 138 141-2 [15], clause A.1.

Table 4.3.25.2.3-1: NR Wide Area BS reference sensitivity parameters

BS channel bandwidth (MHz)	Sub-carrier spacing (kHz)	Reference measurement channel	EIS _{REFSENS} (dBm)	
			f ≤ 3,0 GHz	3,0 GHz < f ≤ 4,2 GHz
5, 10, 15, 25, 30	15	G-FR1-A1-1	-100,4 - Δ _{OTAREFSSENS}	-100,3 - Δ _{OTAREFSSENS}
5, 10, 15, 25, 30	30	G-FR1-A1-2	-100,5 - Δ _{OTAREFSSENS}	-100,4 - Δ _{OTAREFSSENS}
10, 15, 25, 30	60	G-FR1-A1-3	-97,6 - Δ _{OTAREFSSENS}	-97,5 - Δ _{OTAREFSSENS}
20, 40, 50, 60, 70, 80, 90, 100	15	G-FR1-A1-4	-94 - Δ _{OTAREFSSENS}	-93,9 - Δ _{OTAREFSSENS}
20, 40, 50, 60, 70, 80, 90, 100	30	G-FR1-A1-5	-94,3 - Δ _{OTAREFSSENS}	-94,2 - Δ _{OTAREFSSENS}
20, 40, 50, 60, 70, 80, 90, 100	60	G-FR1-A1-6	-94,4 - Δ _{OTAREFSSENS}	-94,3 - Δ _{OTAREFSSENS}
NOTE: EIS _{REFSENS} is the power level of a single instance of the reference measurement channel. This requirement shall be met for each consecutive application of a single instance of the reference measurement channel mapped to disjoint frequency ranges with a width corresponding to the number of resource blocks of the reference measurement channel each, except for one instance that might overlap one other instance to cover the full BS channel bandwidth.				

Table 4.3.25.2.3-2: NR Medium Range BS reference sensitivity parameters

BS channel bandwidth (MHz)	Sub-carrier spacing (kHz)	Reference measurement channel	EIS _{REFSENS} (dBm)	
			f ≤ 3,0 GHz	3,0 GHz < f ≤ 4,2 GHz
5, 10, 15, 25, 30	15	G-FR1-A1-1	-95,4 - Δ _{OTAREFSSENS}	-95,3 - Δ _{OTAREFSSENS}
5, 10, 15, 25, 30	30	G-FR1-A1-2	-95,5 - Δ _{OTAREFSSENS}	-95,4 - Δ _{OTAREFSSENS}
10, 15, 25, 30	60	G-FR1-A1-3	-92,6 - Δ _{OTAREFSSENS}	-92,5 - Δ _{OTAREFSSENS}
20, 40, 50, 60, 70, 80, 90, 100	15	G-FR1-A1-4	-89 - Δ _{OTAREFSSENS}	-88,9 - Δ _{OTAREFSSENS}
20, 40, 50, 60, 70, 80, 90, 100	30	G-FR1-A1-5	-89,3 - Δ _{OTAREFSSENS}	-89,2 - Δ _{OTAREFSSENS}
20, 40, 50, 60, 70, 80, 90, 100	60	G-FR1-A1-6	-89,4 - Δ _{OTAREFSSENS}	-89,3 - Δ _{OTAREFSSENS}

NOTE: EIS_{REFSENS} is the power level of a single instance of the reference measurement channel. This requirement shall be met for each consecutive application of a single instance of the reference measurement channel mapped to disjoint frequency ranges with a width corresponding to the number of resource blocks of the reference measurement channel each, except for one instance that might overlap one other instance to cover the full *BS channel bandwidth*.

Table 4.3.25.2.3-3: NR Local Area BS reference sensitivity parameters

BS channel bandwidth (MHz)	Sub-carrier spacing (kHz)	Reference measurement channel	EIS _{REFSENS} (dBm)	
			f ≤ 3,0 GHz	3,0 GHz < f ≤ 4,2 GHz
5, 10, 15, 25, 30	15	G-FR1-A1-1	-92,4 - Δ _{OTAREFSSENS}	-92,3 - Δ _{OTAREFSSENS}
5, 10, 15, 25, 30	30	G-FR1-A1-2	-92,5 - Δ _{OTAREFSSENS}	-92,4 - Δ _{OTAREFSSENS}
10, 15, 25, 30	60	G-FR1-A1-3	-89,6 - Δ _{OTAREFSSENS}	-89,5 - Δ _{OTAREFSSENS}
20, 40, 50, 60, 70, 80, 90, 100	15	G-FR1-A1-4	-86 - Δ _{OTAREFSSENS}	-85,9 - Δ _{OTAREFSSENS}
20, 40, 50, 60, 70, 80, 90, 100	30	G-FR1-A1-5	-86,3 - Δ _{OTAREFSSENS}	-86,2 - Δ _{OTAREFSSENS}
20, 40, 50, 60, 70, 80, 90, 100	60	G-FR1-A1-6	-86,4 - Δ _{OTAREFSSENS}	-86,3 - Δ _{OTAREFSSENS}

NOTE: EIS_{REFSENS} is the power level of a single instance of the reference measurement channel. This requirement shall be met for each consecutive application of a single instance of the reference measurement channel mapped to disjoint frequency ranges with a width corresponding to the number of resource blocks of the reference measurement channel each, except for one instance that might overlap one other instance to cover the full *BS channel bandwidth*.

4.3.25.3 Conformance

The conformance tests for this requirement shall be as defined in clause 5.3.25 of the present document.

5 Testing for compliance with technical requirements

5.1 Environmental conditions for testing

Tests defined in the present document shall be carried out at representative points within the boundary limits of the operational environmental profile defined by its intended use, which, as a minimum, shall be that specified in the test conditions contained in the present document.

Where technical performance varies subject to environmental conditions, tests shall be carried out under a sufficient variety of environmental conditions as specified in the present document to give confidence of compliance for the affected technical requirements.

All tests are performed using normal test environment, except where otherwise stated. For guidance on the use of other test conditions to be used in order to show compliance, reference can be made to annex B in ETSI TS 137 145-1 [2] and ETSI TS 137 145-2 [3].

5.2 Interpretation of the measurement results

Recommended values for the maximum measurements uncertainty can be found in annex B.

5.3 Essential radio test suites

5.3.1 Introduction

This clause describes the test suites for AAS BS.

The test configurations that used for demonstrating conformance to are specified in clause 5 of ETSI TS 137 145-1 [2] and ETSI TS 137 145-2 [3]. Test configurations shall apply according to the RAT Capability Set (CS) of the AAS BS and the Band Category of the *operating band* (BC1, BC2 or BC3). Transmitter test signals and test models as defined in clauses 4.11.2 and 4.12.2 of ETSI TS 137 145-1 [2] and ETSI TS 137 145-2 [3] are used.

Many tests in the present document are performed with the maximum *Base Station RF bandwidth* located at the bottom, middle and top of the supported frequency range in the *operating band*. These are denoted as B_{RFBW} (bottom), M_{RFBW} (middle) and T_{RFBW} (top) for single-band testing and $B_{\text{RFBW}}-T_{\text{RFBW}}$ and $B'_{\text{RFBW}}-T_{\text{RFBW}}$ for multi-band testing, and are defined in clause 4.12.1 of ETSI TS 137 145-1 [2] and clause 4.12.2 of ETSI TS 137 145-2 [3].

The measurement system for each test is presented for information in ETSI TS 137 145-1 [2], annex D.

5.3.2 *Operating band unwanted emissions*

5.3.2.1 General

The test purpose is to verify that transmitter's unwanted emissions close to the assigned channel bandwidth of the wanted signal do not exceed the specified limits.

5.3.2.2 Initial conditions

Test environment:

- normal; see ETSI TS 137 145-1 [2], clause B.2.

RF channels to be tested for single carrier:

- B, M and T; see clause 5.3.1.

Base Station RF Bandwidth positions to be tested for multi-carrier:

- B_{RFBW} , M_{RFBW} and T_{RFBW} in single-band operation; see clause 5.3.1; $B_{\text{RFBW}}-T_{\text{RFBW}}$ and $B'_{\text{RFBW}}-T_{\text{RFBW}}$ in multi-band operation, see clause 5.3.1.

5.3.2.3 Procedure

- 1) Connect *TAB connector* under test to measurement equipment:

NOTE: Example of measurement setup is in ETSI TS 137 145-1 [2], clause D.1.1.

All *TAB connectors* not under test shall be terminated.

The measurement device characteristics shall be: Detection mode: True RMS.

- 2) Set the set the *TAB connector* to transmit:

- a) For MSR:

- Set the *TAB connector* to transmit maximum power according to the applicable test configuration using the corresponding test models or set of physical channels, see clause 5.3.1.

- b) For E-UTRA:
- *TAB connector* capable of single carrier operation only, set the *TAB connector* to transmit a signal according to E-TM1.1 (ETSI TS 137 145-1 [2], clause 4.12.2) at rated output power $P_{\text{rated,c,TABC}}$
 - For a *TAB connector* capable of multi-carrier and/or CA operation, set the set the *TAB connector* to transmit according to E-TM1.1 (ETSI TS 137 145-1 [2], clause 4.12.2) on all carriers configured using the applicable test configuration and corresponding power setting specified in ETSI TS 137 145-1 [2], clause 4.11.
- 3) Step the centre frequency of the measurement filter in contiguous steps and measure the emission within the specified frequency ranges with the specified *measurement bandwidth*.
- 4) Repeat the test for the remaining test cases:
- a) For MSR with channel set-up according to ETSI TS 137 145-1 [2], clause 5 and ETSI TS 137 145-1 [2], clause 4.12.2.
 - b) For E-UTRA with the channel set-up according to E-TM1.2 (ETSI TS 137 145-1 [2], clause 4.12.2).

In addition, for *multi-band TAB connector(s)*, the following steps shall apply:

- 5) For *multi-band TAB connectors* and single band tests, repeat the steps above per involved band where single band test configurations and test models shall apply with no carrier activated in the other band.

5.3.2.4 Test requirement

The results shall fulfil the conditions and limits of clause 4.3.2.2.

5.3.3 Spectrum Emission Mask (SEM)

5.3.3.1 General

The test purpose is to verify that transmitter's unwanted emissions close to the assigned channel bandwidth of the wanted signal do not exceed the specified limits.

This test is only applicable for AAS BS in single RAT UTRA FDD operation.

5.3.3.2 Initial conditions

Test environment:

- normal; see ETSI TS 137 145-1 [2], clause B.2.

RF channels to be tested for single carrier:

- B, M and T; see clause 5.3.1.

Base Station RF Bandwidth positions to be tested for multi-carrier:

- B_{RFBW} , M_{RFBW} and T_{RFBW} in single-band operation; B'_{RFBW_T} and B'_{RFBW_T} in multi-band operation, see clause 5.3.1.

For a *TAB connector* capable of single carrier operation only, set to transmit a signal according to TM1, in ETSI TS 137 145-1 [2], clause 4.12.2.

For a *multi-carrier TAB connector*, set to transmit according to TM1 on all carriers configured using the applicable test configuration.

5.3.3.3 Procedure

- 1) Connect *TAB connector* under test to measurement equipment.

NOTE: Example of measurement test setup is in ETSI TS 137 145-1 [2], clause D.1.1.

All *TAB connectors* not under test shall be terminated.

The measurement device characteristics shall be:

- Measurements with an offset from the carrier centre frequency between 2,515 MHz and 4,0 MHz shall use a 30 kHz *measurement bandwidth*.
 - Measurements with an offset from the carrier centre frequency between 4,0 MHz and ($f_{\text{offset}_{\text{max}}} - 500$ kHz) shall use a 1 MHz *measurement bandwidth*.
 - Detection mode: True RMS.
- 2) For single carrier operation set the *TAB connector* to transmit at *rated carrier output power per TAB connector* ($P_{\text{Rated,c,TABC}}$).

For a *TAB connector* capable of multi-carrier and/or CA operation set the *TAB connector* to transmit on all carriers configured according to the applicable test configuration using the corresponding test models or set of physical channels, see clause 5.3.1.
 - 3) Step the centre frequency of the measurement filter in contiguous steps and measure the emission within the specified frequency ranges with the specified *measurement bandwidth*. For *multi-band TAB connector* or *TAB connector* operating in *non-contiguous spectrum*, the emission within the Inter RF Bandwidth or *sub-block gap* shall be measured using the specified *measurement bandwidth* from the closest *Base Station RF Bandwidth* or sub-block edge.

In addition, for *multi-band TAB connector(s)*, the following steps shall apply:

- 4) For *multi-band TAB connectors* and single band tests, repeat the steps above per involved band where single band test configurations and test models shall apply with no carrier activated in the other band.

5.3.3.4 Test requirement

The results shall fulfil the conditions and limits of clause 4.3.3.2.

5.3.4 Adjacent Channel Leakage power Ratio (ACLR)

5.3.4.1 General

The test purpose is to verify that the adjacent channel leakage power ratio fulfils the requirements.d

5.3.4.2 Initial conditions

5.3.4.2.1 General test conditions

Test environment:

- Normal; see ETSI TS 137 145-1 [2], clause B.2.

RF channels to be tested for single carrier:

- B, M and T; see clause 5.3.1.

Base Station RF Bandwidth positions to be tested for multi-carrier:

- B_{RFBW} , M_{RFBW} and T_{RFBW} in single-band operation; $B'_{\text{RFBW}}T'_{\text{RFBW}}$ and $B'_{\text{RFBW}}T_{\text{RFBW}}$ in multi-band operation, see clause 5.3.1.

5.3.4.2.2 MSR

For E-UTRA and NR ACLR requirement outside the *Base Station RF Bandwidth edges* and the ACLR requirement applied inside *sub-block gap*, in addition, for *non-contiguous spectrum* operation or *Inter RF Bandwidth gap* for multi-band operation using, the test configurations defined in clause 4.8 in ETSI TS 137 145-1 [2], the method of test described in clause 5.3.4.2.4 applies.

5.3.4.2.3 UTRA FDD

Set the base station to transmit a signal modulated in accordance to TM1, in ETSI TS 137 145-1 [2], clause 4.12.2.

For a *TAB connector* capable of multi-carrier operation, set the base station to transmit according to TM1 on all carriers configured.

5.3.4.2.4 E-UTRA

For a *TAB connector* capable of single carrier operation only set to transmit a signal according to E-TM1.1 in ETSI TS 137 145-1 [2], clause 4.12.2.

For a *TAB connector* capable of multi-carrier and/or CA operation, set to transmit according to E-TM1.1 on all carriers configured.

5.3.4.3 Procedure

5.3.4.3.1 General procedure

- 1) Connect *TAB connector* under test to measurement equipment.

NOTE: Example of measurement test setup is in ETSI TS 137 145-1 [2], clause D.1.1.

All *TAB connectors* not under test shall be terminated.

The measurement device characteristics shall be:

- Measurement filter bandwidth: defined in clause 4.3.4.2;
- Detection mode: true RMS voltage or true average power.

- 2) For single carrier operation set the *TAB connector* to transmit at *rated carrier output power* per *TAB connector* ($P_{\text{Rated,c,TABC}}$).

For a *TAB connector* capable of multi-carrier and/or CA operation set the *TAB connector* to transmit on all carriers configured according to the applicable test configuration using the corresponding test models or set of physical channels, see clause 5.3.1.

5.3.4.3.2 MSR

- 1) For E-UTRA and NR, measure ACLR:
 - Outside the Base Station RF Bandwidth edges.
 - Inside *sub-block gap* for *non-contiguous spectrum* operation as specified in clause 4.3.4.2.3.1 for E-UTRA and 4.3.4.2.3.2 for NR.
 - Inside *Inter RF Bandwidth gap* for multi-band operation.
- 2) For UTRA FDD, measure ACLR inside *sub-block gap* or *Inter RF Bandwidth gap* as specified in clause 4.3.4.2.3.3.
- 3) Measure CA CLR inside *sub-block gap* or the *Inter RF Bandwidth gap* as specified in clause 4.3.4.2.3.4.

In addition, for *multi-band TAB connector(s)*, the following steps shall apply:

- 4) For *multi-band TAB connectors* and single band tests, repeat the steps above per involved band where single band test configurations and test models shall apply with no carrier activated in the other band.

5.3.4.3.3 UTRA FDD

- 1) Measure Adjacent channel leakage power ratio for 5 MHz and 10 MHz offsets both side of channel frequency. In multiple carrier case only offset frequencies below the lowest and above the *highest carrier* frequency used shall be measured.
- 2) For the ACLR requirement applied inside *sub-block gap* for *non-contiguous spectrum* operation or inside *Inter RF Bandwidth gap* for multi-band operation:
 - a) Measure ACLR inside *sub-block gap* or *Inter RF Bandwidth gap* as specified in clause 4.3.4.2.4.1, if applicable.
 - b) Measure CA CLR inside *sub-block gap* or *Inter RF Bandwidth gap* as specified in clause 4.3.4.2.4.2, if applicable.

In addition, for *multi-band TAB connector(s)*, the following steps shall apply:

- 3) For *multi-band TAB connectors* and single band tests, repeat the steps above per involved band where single band test configurations and test models shall apply with no carrier activated in the other band.

5.3.4.3.4 E-UTRA

- 1) Measure Adjacent channel leakage power ratio for the frequency offsets both side of channel frequency as specified in table 4.3.4.2.5.1-1 (Paired spectrum case) or table 4.3.4.2.5.1-2 (Unpaired spectrum case) respectively. In multiple carrier case only offset frequencies below the lowest and above the *highest carrier* frequency used shall be measured.
- 2) For the ACLR requirement applied inside *sub-block gap* for *non-contiguous spectrum* operation: or inside *Inter RF Bandwidth gap* for multi-band operation:
 - a) Measure ACLR inside *sub-block gap* or *Inter RF Bandwidth gap* as specified in clause 4.3.4.2.5.1, if applicable.
 - b) Measure CA CLR inside *sub-block gap* or *Inter RF Bandwidth gap* as specified in clause 4.3.4.2.5.2, if applicable.
- 3) Repeat the test with the channel set-up according to E- TM1.2 in ETSI TS 137 145-1 [2], clause 4.12.2.

In addition, for *multi-band TAB connector(s)*, the following steps shall apply:

- 4) For *multi-band TAB connectors* and single band tests, repeat the steps above per involved band where single band test configurations and test models shall apply with no carrier activated in the other band.

5.3.4.4 Test requirement

The results shall fulfil the conditions and limits of clause 4.3.4.2.

5.3.5 Transmitter spurious emissions

5.3.5.1 General

These tests aim to verify that radiated spurious emissions are within the:

- general spurious emission limits;
- limits for protection of own BS receiver;
- limits for co-existence with other systems.

5.3.5.2 Initial conditions

Test environment:

- normal; see ETSI TS 137 145-1 [2], clause B.2.

RF channels to be tested for single carrier:

- B when testing the spurious frequencies below $F_{DL_low} - \Delta f_{OBUE}$,
- T when testing the spurious frequencies above $F_{DL_high} + \Delta f_{OBUE}$; see clause 5.3.1.

Base Station RF Bandwidth positions to be tested for multi-carrier:

- B_{RFBW} when testing the spurious frequencies below $F_{DL_low} - \Delta f_{OBUE}$;
- T_{RFBW} when testing the spurious frequencies above $F_{DL_high} + \Delta f_{OBUE}$ in single-band operation; see clause 5.3.1;
- $B_{RFBW_T'_{RFBW}}$ when testing the spurious frequencies below $F_{DL_low} - \Delta f_{OBUE}$ of the lowest *operating band*;
 $B_{RFBW_T'_{RFBW}}$ when testing the spurious frequencies below $F_{DL_low} - \Delta f_{OBUE}$ of the lowest *operating band* in multi-band operation, see clause 5.3.1.

5.3.5.3 Procedure

- 1) Connect *TAB connector* under test to measurement equipment.

NOTE: Example of measurement test setup is in ETSI TS 137 145-1 [2], clause D.1.3.

All *TAB connectors* not under test shall be terminated.

- 2) Measurements shall use a *measurement bandwidth* in accordance to the conditions in clause 4.3.5.2.
- 3) The measurement device characteristics shall be:
 - Detection mode: True RMS.
- 4) Set the *TAB connector* to transmit:
 - a) For MSR:
 - Set the *TAB connector* to transmit maximum power according to the applicable test configuration using the corresponding test models or set of physical channels, see clause 5.3.1.
 - b) For UTRA:
 - For a *TAB connector* capable of single carrier operation only, set the *TAB connector* to transmit a signal according to TM1, ETSI TS 137 145-1 [2], clause 4.12.2, at the rated output power, $P_{rated,c,TABC}$.
 - For a *TAB connector* capable of multi-carrier operation, set the set the *TAB connector* to transmit according to TM1 on all carriers configured using the applicable test configuration and corresponding power setting specified in ETSI TS 137 145-1 [2], clause 4.11.
 - c) For E-UTRA:
 - *TAB connector* capable of single carrier operation only, set the *TAB connector* to transmit a signal according to E-TM1.1 in ETSI TS 137 145-1 [2], clause 4.12.2, at rated output power $P_{rated,c,TABC}$.
 - For a *TAB connector* capable of multi-carrier and/or CA operation, set the set the *TAB connector* to transmit according to E-TM1.1 on all carriers configured using the applicable test configuration and corresponding power setting specified in ETSI TS 137 145-1 [2], clause 4.11.
- 5) Measure the emission at the specified frequencies with specified *measurement bandwidth*.

In addition, for *multi-band TAB connector(s)*, the following steps shall apply:

- 6) For *multi-band TAB connectors* and single band tests, repeat the steps above per involved band where single band test configurations and test models shall apply with no carrier activated in the other band.

5.3.5.4 Test requirement

The results shall fulfil the conditions and limits of clause 4.3.5.2.

5.3.6 Base station output power

5.3.6.1 General

The test purpose is to verify the accuracy of the *maximum carrier output power per TAB connector*, $P_{\max,c,TABC}$, across the frequency range and under normal and extreme conditions.

5.3.6.2 Initial conditions

Test environment:

- normal; ETSI TS 137 145-1 [2], clause B.2.
- extreme; ETSI TS 137 145-1 [2], clauses B.3 and B.5.

RF channels to be tested:

- B, M and T; see clause 5.3.1.

Base Station RF Bandwidth positions to be tested:

- B_{RFBW} , M_{RFBW} and T_{RFBW} for *single band TAB connector(s)*, see clause 5.3.1; $B_{RFBW_T'RFBW}$ and $B'_{RFBW_T'RFBW}$ for *multi-band TAB connector(s)*, see clause 5.3.1.

Under extreme test environment, it is sufficient to test on one ARFCN, UARFCN, EARFCN or NR-ARFCN or one *Base Station RF bandwidth* position, and with one applicable test configuration defined in clauses 4.11 and 5 in ETSI TS 137 145-1 [2]. Testing shall be performed under extreme power supply conditions, as defined in clause B.5 in ETSI TS 137 145-1 [2].

NOTE: Tests under extreme power supply conditions also test extreme temperatures.

5.3.6.3 Procedure

- 1) Connect the power measuring equipment to the *TAB connector(s)* under test.

NOTE: Example of measurement test setup is in ETSI TS 137 145-1 [2], clause D.1.1.

All *TAB connectors* not under test shall be terminated.

- 2) Set each *TAB connector* to output according to the applicable test configuration in clause 5 in ETSI TS 137 145-1 [2] using the corresponding test models or set of physical channels in clause 5.3.1. For single carrier set the *TAB connector* to transmit at *rated carrier output power per TAB connector* ($P_{\text{Rated},c,TABC}$).
- 3) Measure the mean power for each carrier at each *TAB connector* under test.

In addition, for *multi-band TAB connector(s)*, the following steps shall apply:

- 4) For *multi-band TAB connectors* and single band tests, repeat the steps above per involved band where single band test configurations and test models shall apply with no carrier activated in the other band.

5.3.6.4 Test requirement

The results shall fulfil the conditions and limits of clause 4.3.6.2.

5.3.7 Transmit intermodulation

5.3.7.1 General

The test purpose is to verify the ability of the transmitter units associated with the *single-band connectors* or *multi-band connector* under test to restrict the generation of intermodulation products in its nonlinear elements caused by the presence of the wanted signal and an interfering signal reaching the transmitter via the antenna to below-specified levels.

5.3.7.2 Initial conditions

Test environment:

- normal; see ETSI TS 137 145-1 [2], clause B.2.

RF channels to be tested for single carrier:

- M; see clause 5.3.1.

Base Station RF Bandwidth positions to be tested for multi-carrier:

- M_{RFBW} in single-band operation; see clause 5.3.1;
- $B_{\text{RFBW_T_RFBW}}$ and $B'_{\text{RFBW_T_RFBW}}$ in multi-band operation, see clause 5.3.1.

5.3.7.3 Procedure

5.3.7.3.1 Procedure for co-location requirement

- 1) Connect *TAB connector* under test to measurement equipment.

NOTE 1: Example of measurement test setup is in ETSI TS 137 145-1 [2], clause D.1.2.

All *TAB connectors* not under test shall be terminated.

- 2) The measurement device characteristics shall be:
 - Detection mode: True RMS.

- 3) Set the set the *TAB connector* to transmit:
 - a) For MSR:
 - Set the *TAB connector* to transmit maximum power according to the applicable test configuration using the corresponding test models or set of physical channels, see clause 5.3.1.
 - b) For UTRA:
 - For a *TAB connector* capable of single carrier operation only, set the *TAB connector* to transmit a signal according to TM1 in ETSI TS 137 145-1 [2], clause 4.12.2, at the rated output power, $P_{\text{rated,c,TABC}}$.
 - For a *TAB connector* capable of multi-carrier operation, set the set the *TAB connector* to transmit according to TM1 on all carriers configured using the applicable test configuration and corresponding power setting specified in ETSI TS 137 145-1 [2], clause 4.11.
 - c) For E-UTRA:
 - *TAB connector* capable of single carrier operation only, set the *TAB connector* to transmit a signal according to E-TM1.1 in ETSI TS 137 145-1 [2], clause 4.12.2, at rated output power $P_{\text{rated,c,TABC}}$.
 - For a *TAB connector* capable of multi-carrier and/or CA operation, set the set the *TAB connector* to transmit according to E-TM1.1 on all carriers configured using the applicable test configuration and corresponding power setting specified in ETSI TS 137 145-1 [2], clause 4.11.

- 4) Generate the interfering signal:
 - a) For MSR:
 - Using E-TM1.1 as defined in ETSI TS 137 145-1 [2], clause 4.12.2, with 5 MHz *channel bandwidth*, at a centre frequency offset according to the conditions in clauses 4.3.7.2.1.1 to 4.3.7.2.1.2, but exclude interfering frequencies that are outside of the allocated downlink *operating band* or interfering frequencies that are not completely within the *sub-block gap* or within the *Inter RF Bandwidth gap*.
 - b) For UTRA FDD:
 - In ETSI TS 137 145-1 [2], accordance to TM1, clause 4.12.2 with a frequency offset of according to the conditions of table 4.3.7.2.2.1-1, but exclude interfering signal frequencies that are outside of the allocated downlink *operating band* or interfering signal frequencies that are not completely within the *sub-block gap* or within the *Inter RF Bandwidth gap*.
 - c) For E-UTRA:
 - According to E-TM1.1 in ETSI TS 137 145-1 [2], as defined in clause 4.12.2, with 5 MHz *channel bandwidth* and a centre frequency offset according to the conditions of table 4.3.7.2.3.1-1, but exclude interfering frequencies that are outside of the allocated downlink *operating band* or interfering frequencies that are not completely within the *sub-block gap* or within the *Inter RF Bandwidth gap*.
- 5) Adjust the level of the interfering signal is as defined in:
 - a) For MSR:
 - i. General co-location table 4.3.7.2.1.1-1.
 - ii. Additional co-location (BC1 and BC2) table 4.3.7.2.1.2-1.
 - b) For UTRA FDD:
 - i. General co-location table 4.3.7.2.2.1-1.
 - c) For E-UTRA:
 - i. General co-location table 4.3.7.2.3.1-1.
- 6) If the test signal is applicable, perform the unwanted emission tests specified in clauses 5.3.2, 5.3.3 and 5.3.4, for all third and fifth order intermodulation products which appear in the frequency ranges defined in clauses 5.3.2, 5.3.3 and 5.3.4. The width of the intermodulation products shall be taken into account.
- 7) If the test signal is applicable, perform the Transmitter spurious emissions test as specified in clause 5.3.5, for all third and fifth order intermodulation products which appear in the frequency ranges defined in clause 5.3.5. The width of the intermodulation products shall be taken into account.
- 8) Verify that the emission level does not exceed the limit in clause 5.3.7.4 with the exception of interfering signal frequencies.
- 9) Repeat the test for the remaining interfering signal centre frequency offsets according to the conditions of:
 - a) For MSR:
 - i. General co-location table 4.3.7.2.1.1-1.
 - ii. Additional co-location (BC1 and BC2) table 4.3.7.2.1.2-1.
 - b) For UTRA FDD:
 - i. General co-location table 4.3.7.2.2.1-1.
 - c) For E-UTRA:
 - i. General co-location table 4.3.7.2.3.1-1.

- 10) Repeat the test for the remaining test signals for requirements in clauses 5.3.2, 5.3.3 and 5.3.4.

In addition, for *multi-band TAB connector(s)*, the following steps shall apply:

- 11) For *multi-band TAB connectors* and single band tests, repeat the steps above per involved band where single band test configurations and test models shall apply with no carrier activated in the other band.

NOTE 2: The third order intermodulation products are centred at $2F1 \pm F2$ and $2F2 \pm F1$. The fifth order intermodulation products are centred at $3F1 \pm 2F2$, $3F2 \pm 2F1$, $4F1 \pm F2$, and $4F2 \pm F1$ where $F1$ represents the test signal centre frequency or centre frequency of each *sub-block* and $F2$ represents the interfering signal centre frequency. The widths of intermodulation products are:

- $(n \times BW_{F1} + m \times BW_{F2})$ for the $nF1 \pm mF2$ products;
- $(n \times BW_{F2} + m \times BW_{F1})$ for the $nF2 \pm mF1$ products;

where BW_{F1} represents the test signal RF bandwidth or *channel bandwidth* in case of single carrier, or *sub-block* bandwidth, and BW_{F2} represents interfering signal bandwidth.

5.3.7.3.2 Procedure for intra-system requirement

- 1) Necessary interfering signal power level at each *TAB connector* is determined as the sum of the co-channel leakage power coupled via the composite antenna connected to the transceiver unit array from all the other *TAB connectors*, without including power radiated from the Antenna Array and reflected back from the environment.
- 2) Connect *TAB connector* to measurement equipment.

NOTE: Example of measurement test setup is in as shown in ETSI TS 137 145-1 [2], clause D.1.2.

All *TAB connectors* not under test shall be terminated.

- 3) The measurement device characteristics shall be:
 - Detection mode: True RMS.
- 4) Set the set the *TAB connector* to transmit:
 - a) For MSR:
 - Set the *TAB connector* to transmit maximum power according to the applicable test configuration using the corresponding test models or set of physical channels, see clause 5.3.1.
 - b) For UTRA:
 - For a *TAB connector* capable of single carrier operation only, set the *TAB connector* to transmit a signal according to TM1 in ETSI TS 137 145-1 [2], clause 4.12.2, at the rated output power, $P_{\text{rated,c,TABC}}$.
 - For a *TAB connector* capable of multi-carrier operation, set the set the *TAB connector* to transmit according to TM1 on all carriers configured using the applicable test configuration and corresponding power setting specified in ETSI TS 137 145-1 [2], clause 4.11.
 - c) For E-UTRA:
 - *TAB connector* capable of single carrier operation only, set the *TAB connector* to transmit a signal according to E-TM1.1 in ETSI TS 137 145-1 [2], clause 4.12.2, at rated output power $P_{\text{rated,c,TABC}}$.
 - For a *TAB connector* capable of multi-carrier and/or CA operation, set the set the *TAB connector* to transmit according to E-TM1.1 on all carriers configured using the applicable test configuration and corresponding power setting specified in ETSI TS 137 145-1 [2], clause 4.11.
- 5) Generate the interfering signal with the same configuration as the wanted signal.
- 6) Adjust so that level of the interfering signal is equal to the level determined in step 1 (e.g. by means of an attenuator).

- 7) Perform the unwanted emission tests specified in clauses 5.3.2, 5.3.3 and 5.3.4.

In addition, for *multi-band TAB connectors*, the following steps shall apply:

- 8) For a *multi-band TAB connectors* and single band tests, repeat the steps above per involved *operating band* where single band test configurations and test models shall apply with no carrier activated in the other *operating band*.

5.3.7.4 Test requirement

The results shall fulfil the conditions and limits of clause 4.3.7.2.

5.3.8 Receiver spurious emissions

5.3.8.1 General

The test purpose is to verify the ability of the BS to limit the interference caused by receiver spurious emissions to other systems.

5.3.8.2 Initial conditions

Test environment:

- Normal; see ETSI TS 137 145-1 [2], clause B.2.

RF channels to be tested for single carrier:

- M; see clause 5.3.1.

Base Station RF Bandwidth positions to be tested for multi-carrier:

- M_{RFBW} in single-band operation, $B_{\text{RFBW_T'RFBW}}$ and $B'_{\text{RFBW_T'RFBW}}$ in multi-band operation, see clause 5.3.1.

5.3.8.3 Procedure

- 1) Connect *TAB connector* under test to measurement equipment.

NOTE: Example of measurement test setup is in ETSI TS 137 145-1 [2], clause D.2.4.

All *TAB connectors* not under test shall be terminated.

- 2) Set the measurement equipment parameters as specified in clause 4.3.8.2.

The measurement device characteristics shall be:

- Detection mode: True RMS.

- 3) Set the transmitter unit associated with the *TAB connector* under test to transmit with the carrier set-up and power allocation according to the applicable test configuration(s), see ETSI TS 137 145-1 [2], clause 5.
- 4) Measure the spurious emissions over each frequency range described in clause 4.3.8.2..

In addition, for *multi-band TAB connector(s)*, the following steps shall apply:

- 5) For *multi-band TAB connectors* and single band tests, repeat the steps above per involved band where single band test configurations and test models shall apply with no carrier activated in the other band.

5.3.8.4 Test requirement

The results shall fulfil the conditions and limits of clause 4.3.8.2.

5.3.9 Blocking

5.3.9.1 General

The test stresses the ability of the receiver unit associated with the *RIB* under test to withstand high-level interference from unwanted signals at specified frequency bands, without undue degradation of its sensitivity.

5.3.9.2 Initial conditions

Test environment:

- Normal; see ETSI TS 137 145-1 [2], clause B.2.

RF channels to be tested for Single Carrier (SC):

- M; see clause 5.3.1.

Base Station RF Bandwidth positions to be tested for Multi-Carrier (MC):

- M_{RFBW} for *single-band TAB connector(s)*, see clause 5.3.1, $B_{\text{RFBW_T'RFBW}}$ and $B'_{\text{RFBW_T'RFBW}}$ for *multi-band TAB connector(s)*, see clause 5.3.1.

In addition, for *multi-band TAB connectors*:

- For $B_{\text{RFBW_T'RFBW}}$, out-of-band blocking testing above the highest *operating band* may be omitted.
- For $B'_{\text{RFBW_T'RFBW}}$, out-of-band blocking testing below the lowest *operating band* may be omitted.

5.3.9.3 Procedure

5.3.9.3.1 General procedure

The general procedure steps apply to the procedures for all the RATs.

The limit applies to all *TAB connectors*, the procedure is repeated until all *TAB connectors* necessary to demonstrate conformance have been tested; see clause 4.3.1:

- 1) Connect *TAB connector* under test to measurement equipment.

NOTE: Example of measurement test setup is in ETSI TS 137 145-1 [2], clause D.2.3.

All *TAB connectors* not under test shall be terminated.

5.3.9.3.2 *MSR operation*

- 1) Generate the wanted signal according to the applicable test configuration (see ETSI TS 137 145-1 [2], clause 5) using applicable reference measurement channel to the *TAB connector* under test.
- 2) Set the transmitter unit associated with the *TAB connector* under test to transmit with the carrier set-up and power allocation according to the applicable test configuration(s) (see ETSI TS 137 145-1 [2], clause 5).

The transmitter unit associated with the *TAB connector* under test may be turned off for the out-of-band blocker tests when the frequency of the blocker is such that no IM2 or IM3 products fall inside the bandwidth of the wanted signal.

- 3) Adjust the signal generators to the type of interfering signals, levels and the frequency offsets as specified for general limits in table 4.3.9.2.1-1.
- 4) The CW interfering signal shall be swept with a step size of 1 MHz within the specified range.
- 5) Measure the performance of the wanted signal at the receiver unit associated with the *TAB connector*, as defined in the clause 4.3.9.2.1, for the carriers specified by the test configuration in ETSI TS 137 145-1 [2], clause 4.11.

In addition, for *multi-band TAB connector(s)*, the following steps shall apply:

- 6) For *multi-band TAB connectors* and single band tests, repeat the steps above per involved band where single band test configurations and test models shall apply with no carrier activated in the other band.

5.3.9.3.3 Single RAT UTRA FDD operation

- 1) Generate the wanted signal according to the applicable test configuration (see ETSI TS 137 145-1 [2], clause 5) using applicable reference measurement channel to the *TAB connector* under test as shown in ETSI TS 125 141 [7], clause A.2.1.
- 2) Set the transmitter unit associated with the *TAB connector* under test to transmit with the carrier set-up and power allocation according to the applicable test configuration(s) (see ETSI TS 137 145-1 [2], clause 5).

The transmitter unit associated with the *TAB connector* under test may be turned off for the out-of-band blocker tests when the frequency of the blocker is such that no IM2 or IM3 products fall inside the bandwidth of the wanted signal.

- 3) Adjust the signal generators to the type of interfering signals and the frequency offsets as specified in tables 4.3.9.2.2-1 to 4.3.9.2.2-6.
- 4) Measure the BER of the wanted signal at the receiver unit associated with the *TAB connector* under test.

In addition, for *multi-band TAB connector(s)*, the following steps shall apply:

- 5) For *multi-band TAB connectors* and single band tests, repeat the steps above per involved band where single band test configurations and test models shall apply with no carrier activated in the other band.

5.3.9.3.4 Single RAT E-UTRA operation

- 1) Generate the wanted signal according to the applicable test configuration (see ETSI TS 137 145-1 [2], clause 5) using applicable reference measurement channel to the *TAB connector* under test as specified in clause 4.3.12.2.2 for E-UTRA to the *TAB connector*.

- 2) Set the transmitter unit associated with the *TAB connector* under test to transmit with the carrier set-up and power allocation according to the applicable test configuration(s) (see ETSI TS 137 145-1 [2], clause 5).

The transmitter unit associated with the *TAB connector* under test may be turned off for the out-of-band blocker tests when the frequency of the blocker is such that no IM2 or IM3 products fall inside the bandwidth of the wanted signal.

- 3) Adjust the signal generators to the type of interfering signals, levels and the frequency offsets as specified for general limits in table 4.3.9.2.3-1 for Wide Area BS, table 4.3.9.2.3-2 for Medium Range BS and table 4.3.9.2.3-3 for Local Area BS.
- 4) The CW interfering signal shall be swept with a step size of 1 MHz within the specified range.
- 5) Measure the performance of the wanted signal at the receiver unit associated with the *TAB connector*, as defined in the clause 4.3.9.2.3, for the carriers specified by the test configuration in ETSI TS 137 145-1 [2], clause 4.11.

In addition, for *multi-band TAB connector(s)*, the following steps shall apply:

- 6) For *multi-band TAB connectors* and single band tests, repeat the steps above per involved band where single band test configurations and test models shall apply with no carrier activated in the other band.

5.3.9.4 Test requirement

The results shall fulfil the conditions and limits of clause 4.3.9.2.

5.3.10 Receiver intermodulation characteristics

5.3.10.1 General

The test purpose is to verify the ability of the receiver unit associated with the *TAB connector* under test to inhibit the generation of intermodulation products in its non-linear elements caused by the presence of two high-level interfering signals at frequencies with a specific relationship to the frequency of the wanted signal.

5.3.10.2 Initial conditions

Test environment:

- Normal; see ETSI TS 137 145-1 [2], clause B.2.

RF channels to be tested for Single Carrier (SC):

- M; see clause 5.3.1.

Base Station RF Bandwidth positions to be tested:

- For *single-band TAB connector(s)*: M_{RFBW} if ATC4 is applicable; B_{RFBW} and T_{RFBW} for other ATC, see clause 5.3.1.

NOTE: ATC is defined in ETSI TS 137 145-1 [2].

- For *multi-band TAB connector(s)*: $B_{\text{RFBW}}T_{\text{RFBW}}$ and $B'_{\text{RFBW}}T_{\text{RFBW}}$, see clause 5.3.1.

5.3.10.3 Procedure

5.3.10.3.1 General procedure

The general procedure steps apply to the procedures for all the RATs.

The limit applies to all *TAB connectors*, the procedure is repeated until all *TAB connectors* necessary to demonstrate conformance have been tested; see clause 5.3.1.

- 1) Connect *TAB connector* under test to measurement equipment.

NOTE: Example of measurement test setup is in ETSI TS 137 145-1 [2], clause D.2.6.

All *TAB connectors* not under test shall be terminated.

- 2) Generate the wanted signal according to the applicable test configuration using applicable reference measurement channel to the *TAB connector* under test.
- 3) Set the transmitter unit associated with the *TAB connector* under test to transmit with the carrier set-up and power allocation according to the applicable test configuration(s) (see clause 5.3.1).

5.3.10.3.2 MSR procedure

5.3.10.3.2.1 Procedure for general and narrowband intermodulation

- 1) Adjust the signal generators to the type of interfering signals, levels and the frequency offsets as specified in tables 4.3.10.2.1.1-1 and 4.3.10.2.1.1-2 for general intermodulation requirement, and tables 4.3.10.2.1.2-1 and 4.3.10.2.1.2-2 for narrowband intermodulation requirement.
- 2) Measure the performance of the wanted signal at the receiver unit associated with the *TAB connector* under test, as defined in clauses 4.3.10.2.1.1 and 4.3.10.2.1.2, for the carriers specified by the test configuration in clause 4.2.

In addition, for *multi-band TAB connector(s)*, the following steps shall apply:

- 3) For *multi-band TAB connectors* and single band tests, repeat the steps above per involved band where single band test configurations and test models shall apply with no carrier activated in the other band.

5.3.10.3.3 Procedure for single RAT UTRA FDD operation

- 1) Generate the wanted signal (reference signal) and adjust the signal level to the *TAB connector* under test to the level specified in table 4.3.10.2.2-1. For a *TAB connector* supporting multi-carrier operation, generate the wanted signal according to the applicable test configuration (see ETSI TS 137 145-1 [2], clause 4.11) using applicable reference measurement channel to the *TAB connector* under test. Power settings are specified in table 4.3.10.2.2-1.
- 2) Adjust the signal generators to the type of interfering signals and the frequency offsets as specified in tables 4.3.10.2.2-1 and 4.3.10.2.2-2.
- 3) Set the specified level of interfering signal at the *TAB connector*.
- 4) Measure the BER of the wanted signal. For a *TAB connector* supporting multi-carrier operation the BER shall be measured for all carriers specified by the test configuration.

In addition, for *multi-band TAB connector(s)*, the following steps shall apply:

- 5) For *multi-band TAB connectors* and single band tests, repeat the steps above per involved band where single band test configurations and test models shall apply with no carrier activated in the other band.

5.3.10.3.4 Procedure for single RAT E-UTRA operation

- 1) Generate the wanted signal using the applicable test configuration specified in ETSI TS 137 145-1 [2], clause 5 and adjust the signal level to the *TAB connector* under test to the level specified in clause 4.3.10.2.3.
- 2) Adjust the signal generators to the type of interfering signals, levels and the frequency offsets as specified in tables 4.3.10.2.1.1-1 and 4.3.10.2.1.1-2 for general intermodulation requirement, and tables 4.3.10.2.1.2-1 and 4.3.10.2.1.2-2 for narrowband intermodulation requirement.
- 3) Adjust the signal generators to obtain the specified level of interfering signal at the *TAB connector*.
- 4) Measure the *throughput*, for multi-carrier and/or CA operation the *throughput* shall be measured for carriers specified by the test configuration specified in ETSI TS 137 145-1 [2], clause 4.11.

In addition, for *multi-band TAB connector(s)*, the following steps shall apply:

- 5) For *multi-band TAB connectors* and single band tests, repeat the steps above per involved band where single band test configurations and test models shall apply with no carrier activated in the other band.

5.3.10.4 Test requirement

The results shall fulfil the conditions and limits of clause 4.3.10.2.

5.3.11 Adjacent Channel Selectivity (ACS), general blocking and narrowband blocking

5.3.11.1 General

The test verifies the receiver unit ability to withstand high-level interference from unwanted signals at specified frequency offsets without undue degradation of its sensitivity.

5.3.11.2 Initial conditions

Test environment:

- Normal; see ETSI TS 137 145-1 [2], clause B.2.

RF channels to be tested for Single Carrier (SC):

- M; see clause 5.3.1.

Base Station RF Bandwidth positions to be tested for Multi-Carrier (MC):

- M_{RFBW} for *single-band TAB connector(s)*, see clause 5.3.1, $B_{\text{RFBW_T}^{\text{RFBW}}}$ and $B'_{\text{RFBW_T}^{\text{RFBW}}}$ for *multi-band TAB connector(s)*, see clause 5.3.1.

5.3.11.3 Procedure

5.3.11.3.1 General procedure

The general procedure steps apply to the procedures for all the RATs.

The limit is applied to all *TAB connectors*, the procedure is repeated until all *TAB connectors* necessary to demonstrate conformance have been tested; see clause 4.3.1.

- 1) Connect *TAB connector* under test to measurement equipment.

NOTE: Example of measurement test setup is in ETSI TS 137 145-1 [2], clause D.2.3.

All *TAB connectors* not under test shall be terminated.

- 2) Generate the wanted signal according to the applicable test configuration (see ETSI TS 137 145-1 [2], clause 5) using applicable reference measurement channel to the *TAB connector*.
- 3) Set the transmitter unit associated with the *TAB connector* under test to transmit with the carrier set-up and power allocation according to the applicable test configuration(s) (see ETSI TS 137 145-1 [2], clause 5).

5.3.11.3.2 MSR operation

5.3.11.3.2.1 Procedure for general blocking

- 1) Adjust the signal generators to the type of interfering signal, levels and the frequency offsets as specified in table 4.3.11.2.1.1-1.
- 2) The interfering signal shall be swept with a step size of 1 MHz starting from the minimum offset to the *channel edges* of the wanted signals as specified in table 4.3.11.2.1.1-1.
- 3) Measure the performance of the wanted signal at the receiver unit associated with the *TAB connector* under test, as defined in clause 4.3.11.2, for the carriers specified by the test configuration in ETSI TS 137 145-1 [2], clause 4.11.

In addition, for *multi-band TAB connector(s)*, the following steps shall apply:

- 4) For *multi-band TAB connectors* and single band tests, repeat the steps above per involved band where single band test configurations and test models shall apply with no carrier activated in the other band.

5.3.11.3.2.2 Procedure for narrowband blocking

- 1) Adjust the signal generators to the type of interfering signal, levels and the frequency offsets as specified in table 4.3.11.2.1.2-1.
- 2) Set-up and sweep the interfering RB centre frequency offset to the *channel edge* of the wanted signal according to table 4.3.11.2.1.2-1-1.
- 3) Measure the performance of the wanted signal at the receiver unit associated with the *TAB connector* under test, as defined in clause 4.3.11.2, for the carriers specified by the test configuration in ETSI TS 137 145-1 [2], clause 4.11.

In addition, for *multi-band TAB connector(s)*, the following steps shall apply:

- 4) For *multi-band TAB connectors* and single band tests, repeat the steps above per involved band where single band test configurations and test models shall apply with no carrier activated in the other band.

5.3.11.3.3 Single RAT UTRA FDD operation

- 1) Generate the wanted signal with the level specified in table 4.3.11.2.2-1 For a *TAB connector* supporting multi-carrier operation, generate the wanted signal according to the applicable test configuration (see ETSI TS 137 145-1 [2], clause 5) using applicable reference measurement channel to the *TAB connector* under test. Power settings are specified in table 4.3.11.2.2-1.
- 2) Set-up the interfering signal at the adjacent channel frequency and adjust the ATT2 to obtain the specified level of interfering signal at the base station input defined in table 4.3.11.2.2-1. The interfering signal shall have an ACLR of at least 63 dB in order to eliminate the impact of interfering signal adjacent channel leakage power on the ACS measurement.
- 3) Measure the BER of the wanted signal at the receiver unit associated with the *TAB connector* under test.

In addition, for *multi-band TAB connector(s)*, the following steps shall apply:

- 4) For *multi-band TAB connectors* and single band tests, repeat the steps above per involved band where single band test configurations and test models shall apply with no carrier activated in the other band.

5.3.11.3.4 Single RAT E-UTRA operation

5.3.11.3.4.1 Procedure for adjacent channel selectivity

- 1) Generate the wanted signal using the applicable test configuration specified in ETSI TS 137 145-1 [2], clause 5.3.4 and adjust the input level to the *TAB connector* under test to the level specified in tables 4.3.11.2.3-3 to 4.3.11.2.3-5 for the appropriate *BS class*.
- 2) Set-up the interfering signal at the adjacent channel frequency and adjust the interfering signal level at the *TAB connector* under test to the level defined in tables 4.3.11.2.3-3 to 4.3.11.2.3-5 for the appropriate *BS class*.
- 3) Measure the *throughput*, for multi-carrier and/or CA operation the *throughput* shall be measured for carriers specified by the test configuration specified in ETSI TS 137 145-1 [2], clause 5.3.4.

In addition, for *multi-band TAB connector(s)*, the following steps shall apply:

- 4) For *multi-band TAB connectors* and single band tests, repeat the steps above per involved band where single band test configurations and test models shall apply with no carrier activated in the other band.

5.3.11.3.4.2 Procedure for narrow-band blocking

- 1) For *TAB connector* operating E-UTRA FDD capable of single carrier operation only in the *operating band*, set the transmitter unit associated with the *TAB connector* under test to transmit according to ETSI TS 137 145-1 [2], clause 4.12.2 at *rated output power* $P_{\text{Rated,c,TABC}}$.

For a *TAB connector* operating E-UTRA FDD capable of multi-carrier and/or CA operation in the *operating band*, set the transmitter unit associated with the *TAB connector* under test to transmit according to ETSI TS 137 145-1 [2], clause 4.12.2 on all carriers configured using the applicable test configuration and corresponding power setting specified in ETSI TS 137 145-1 [2], clause 5.3.4.
- 2) Generate the wanted signal using the applicable test configuration specified in clause 5.3.4 and adjust the input level to the *TAB connector* under test to the level specified in table 4.3.11.2.3-1.
- 3) Adjust the interfering signal level at the *TAB connector* input to the level defined in table 4.3.11.2.3-1. Set-up and sweep the interfering RB centre frequency offset to the *channel edge* of the wanted signal according to table 4.3.11.2.3-2.
- 4) Measure the *throughput*, for multi-carrier and/or CA operation the *throughput* shall be measured for carriers specified by the test configuration specified in ETSI TS 137 145-1 [2], clause 5.3.4.

In addition, for *multi-band TAB connector(s)*, the following steps shall apply:

- 5) For *multi-band TAB connectors* and single band tests, repeat the steps above per involved band where single band test configurations and test models shall apply with no carrier activated in the other band.

5.3.11.4 Test requirement

The results shall fulfil the conditions and limits of clause 4.3.11.2.

5.3.12 Reference sensitivity level

5.3.12.1 General

Test purpose is to verify that for each *TAB connector* the *throughput* or BER requirement is met at P_{REFSENS} .

5.3.12.2 Initial conditions

Test environment:

- Normal; see ETSI TS 137 145-1 [2], clause B.2.
- Extreme: see ETSI TS 137 145-1 [2], clauses B.3 and B.5.

RF channels to be tested for single carrier:

- B, M and T; see clause 5.3.1.

Under extreme test environment the test shall be performed on each of B, M and T under extreme power supply conditions as defined in ETSI TS 138 141-1 [12], clause B.5.

NOTE: Tests under extreme power supply conditions also test extreme temperatures.

5.3.12.3 Procedure

The limit applies to all *TAB connectors*, the procedure is repeated until all *TAB connectors* necessary to demonstrate conformance have been tested; see clause 4.3.1.

- 1) Connect *TAB connector* under test to measurement equipment.

NOTE: Example of measurement test setup is in ETSI TS 137 145-1 [2], clause D.2.1.

All *TAB connectors* not under test shall be terminated.

- 2) Set all *TAB connectors* in the same RAT and *operating band* to transmit a signal according to ETSI TS 137 145-1 [2], clause 4.12.2 at *rated output power* $P_{\text{Rated,c,TABC}}$.
- 3) Generate the wanted signal according to the applicable test configuration (see ETSI TS 137 145-1 [2], clause 5) using applicable reference measurement channel to the *TAB connector* under test.
- 4) For UTRA FDD disable the TPC function.
- 5) Set the signal generator for the wanted signal power as specified in clause 4.3.12.2.
- 6) Measure BER (UTRA) and *throughput* (E-UTRA and NR) for applicable reference measurement channels.

In addition, for *multi-band TAB connector(s)*, the following steps shall apply:

- 7) For *multi-band TAB connectors* and single band tests, repeat the steps above per involved band where single band test configurations and test models shall apply with no carrier activated in the other band.

5.3.12.4 Test requirement

The results shall fulfil the conditions and limits of clause 4.3.12.2.

5.3.13 OTA operating band unwanted emissions

5.3.13.1 General

The test purpose is to verify that transmitter's unwanted emissions close to the assigned channel bandwidth of the wanted signal do not exceed the specified limits.

5.3.13.2 Initial conditions

Test environment:

- Normal; see ETSI TS 137 145-2 [3], clause G.2.

RF channels to be tested for single carrier:

- B, M and T; see clause 5.3.1.

Base Station RF Bandwidth positions to be tested for multi-carrier:

- B_{RFBW} , M_{RFBW} and T_{RFBW} in single-band operation; $B'_{\text{RFBW}}T_{\text{RFBW}}$ and $B'_{\text{RFBW}}T_{\text{RFBW}}$ in multi-band operation, see clause 5.3.1.

Directions to be tested:

- As the requirement is based on TRP the beam pattern(s) may be set up to optimize the TRP measurement procedure (see annex F in ETSI TS 137 145-2 [3])

5.3.13.3 Procedure

The following procedure for measuring TRP is based on the directional power measurements as described in ETSI TS 137 145-2 [3], annex F. An alternative method to measure TRP is to use a characterized and calibrated reverberation chamber if so follow steps 1, 3, 4, 6, 9 and 10. When calibrated and operated within the guidance of ETSI TR 137 941 [i.27] the two methods are applicable and selected due to availability of test facility:

- 1) Place the AAS BS at the positioner.
- 2) Align the coordinate system orientation (D9.2) of the AAS BS with the test system.
- 3) The measurement devices characteristics shall be:
 - detection mode: true RMS.
- 4) Set the AAS BS to transmit:
 - a) For MSR:
 - Set the AAS BS to transmit maximum power according to the applicable test configuration using the corresponding test models or set of physical channels, see clause 5.3.1.
 - b) For E-UTRA:
 - AAS BS capable of single carrier operation only, set the AAS BS to transmit a signal according to E-TM1.1 (ETSI TS 137 145-2 [3], clause 4.12.2) at *rated carrier TRP* ($P_{\text{Rated,c,TRP}}$).
 - For an AAS BS capable of multi-carrier and/or CA operation, set the set the AAS BS to transmit according to E-TM1.1 on all carriers configured using the applicable test configuration and corresponding power setting specified in ETSI TS 137 145-2 [3], clause 4.11.
- 5) Orient the positioner (and BS) in order that the direction to be tested aligns with the test antenna such that measurements to determine TRP can be performed (see ETSI TS 137 145-2 [3], annex F).
- 6) Sweep the centre frequency of the measurement filter in contiguous steps and measure emission power within the specified frequency ranges with the specified *measurement bandwidth*.

- 7) Repeat steps 6 and 7 for all directions in the appropriate TRP measurement grid needed for $TRP_{Estimate}$ (see ETSI TS 137 145-2 [3], annex F).
- 8) Calculate $TRP_{Estimate}$ using the measurements made in step 7.
- 9) Repeat the test for the remaining test cases:
 - a) For MSR with channel set-up according to ETSI TS 137 145-2 [3], clause 5 and ETSI TS 137 145-2 [3], clause 4.12.2.
 - b) For E-UTRA with the channel set-up according to E-TM 1.2.

In addition, for *multi-band RIB*, the following steps shall apply:

- 10) For *multi-band RIB* and single band tests, repeat the steps above per involved band where single band test configurations and test models shall apply with no carrier activated in the other band.

5.3.13.4 Test requirement

The results shall fulfil the conditions and limits of clause 4.3.13.2.

5.3.14 OTA Spectrum Emission Mask (OTA SEM)

5.3.14.1 General

The test purpose is to verify that transmitter's unwanted emissions close to the assigned channel bandwidth of the wanted signal do not exceed the specified limits.

This test is only applicable for AAS BS in single RAT UTRA FDD operation.

5.3.14.2 Initial conditions

Test environment:

- normal; see ETSI TS 137 145-2 [3], clause G.2.

RF channels to be tested for single carrier:

- B, M and T; see clause 5.3.1.

Base Station RF Bandwidth positions to be tested for multi-carrier:

- B_{RFBW} , M_{RFBW} and T_{RFBW} in single-band operation; $B_{RFBW_T_{RFBW}}$ and $B'_{RFBW_T_{RFBW}}$ in multi-band operation, see clause 5.3.1.

For an AAS BS capable of single carrier operation only, set to transmit a signal according to TM1, in ETSI TS 137 145-2 [3], clause 4.12.2.

For a multi-carrier capable AAS BS, set to transmit according to TM1 on all carriers configured using the applicable test configuration.

5.3.14.3 Procedure

The following procedure for measuring TRP is based on the directional power measurements as described in in annex F in ETSI TS 137 145-2 [3]. An alternative method to measure TRP is to use a characterized and calibrated reverberation chamber if so follow steps 1, 3, 4, 5, 7 and 10. When calibrated and operated within the guidance of ETSI TR 137 941 [i.27] the two methods are applicable and selected due to availability of test facility:

- 1) Place the AAS BS at the positioner.
- 2) Align the coordinate system orientation (D9.2) of the AAS BS with the test system.

- 3) The measurement devices characteristics shall be:
 - a 30 kHz *measurement bandwidth*;
 - measurements with an offset from the carrier centre frequency between 2,515 MHz and 4,0 MHz shall use Measurements with an offset from the carrier centre frequency between 4,0 MHz and ($f_{\text{offset_max}} - 500$ kHz) shall use a 1 MHz *measurement bandwidth*;
 - detection mode: true RMS.
- 4) For single carrier operation, set the AAS BS to transmit according to the applicable test configuration in clause 5 using the corresponding test model(s) in ETSI TS 137 145-2 [3], clause 4.12.2 at *rated carrier TRP* ($P_{\text{rated,c,TRP}}$).

For an AAS BS capable of multi-carrier and/or CA operation use the applicable test signal configuration and corresponding power setting specified in ETSI TS 137 145-2 [3], clause 4.11.
- 5) For UTRA FDD *multi-band RIB* or *RIB* operating in *non-contiguous spectrum*, the emission within the Inter RF Bandwidth or *sub-block gap* shall be measured using the specified *measurement bandwidth* from the closest *Base Station RF Bandwidth* or sub-block edge.
- 6) Orient the positioner (and BS) in order that the direction to be tested aligns with the test antenna such that measurements to determine TRP can be performed (see ETSI TS 137 145-2 [3], annex F).
- 7) Sweep the centre frequency of the measurement filter in contiguous steps and measure emission power within the specified frequency ranges with the specified *measurement bandwidth*.
- 8) Repeat steps 6) and 7) for all directions in the appropriate TRP measurement grid needed for $\text{TRP}_{\text{Estimate}}$ (see ETSI TS 137 145-2 [3], annex F).
- 9) Calculate $\text{TRP}_{\text{Estimate}}$ using the measurements made in step 7.

In addition, for *multi-band RIB*, the following steps shall apply:

- 10) For *multi-band RIB* and single band tests, repeat the steps above per involved band where single band test configurations and test models shall apply with no carrier activated in the other band.

5.3.14.4 Test requirement

The results shall fulfil the conditions and limits of clause 4.3.14.2.

5.3.15 OTA Adjacent Channel Leakage power Ratio (OTA ACLR)

5.3.15.1 General

The test purpose is to verify that the adjacent channel leakage power ratio fulfils the requirements.

5.3.15.2 Initial conditions

5.3.15.2.1 General test conditions

Test environment:

- Normal; see ETSI TS 137 145-2 [3], clause G.2.

RF channels to be tested for single carrier:

- B and T; see clause 5.3.1.

Base Station RF Bandwidth positions to be tested for multi-carrier:

- B_{RFBW} and T_{RFBW} in single-band operation; see clause 5.3.1;

- $B_{\text{RFBW}} T_{\text{RFBW}}$ and $B'_{\text{RFBW}} T_{\text{RFBW}}$ in multi-band operation, see clause 5.3.1.

5.3.15.2.2 MSR

For E-UTRA ACLR requirement outside the *Base Station RF Bandwidth edges* and the ACLR requirement applied inside *sub-block gap*, in addition, for *non-contiguous spectrum* operation or *Inter RF Bandwidth gap* for multi-band operation using, the test configurations defined in clause 4.8 in ETSI TS 137 145-2 [3], the method of test described in clause 6.7.3.4.2 in ETSI TS 137 145-2 [3] applies.

5.3.15.2.3 UTRA FDD

Set the AAS BS to transmit a signal modulated in accordance to TM1 in ETSI TS 137 145-2 [3], clause 4.12.2.

For an AAS BS capable of multi-carrier operation, set the base station to transmit according to TM1 on all carriers configured.

5.3.15.2.4 E-UTRA

For an AAS BS capable of single carrier operation only set to transmit a signal according to E-TM1.1 in ETSI TS 137 145-2 [3] clause 4.12.2.

For an AAS BS capable of multi-carrier and/or CA operation, set to transmit according to E-TM1.1 on all carriers configured.

5.3.15.2.5 NR

For an AAS BS capable of single carrier operation only set to transmit a signal according to NR-FR1-TM1.1 in ETSI TS 137 145-2 [3], clause 4.12.2.

For an AAS BS capable of multi-carrier and/or CA operation, set to transmit according to NR-FR1-TM1.1 on all carriers configured.

5.3.15.3 Procedure

5.3.15.3.1 General procedure

The following procedure for measuring TRP is based on the directional power measurements as described in annex F in ETSI TS 137 145-2 [3]. An alternative method to measure TRP is to use a characterized and calibrated reverberation chamber if so follow steps 1, 3, 4, 6 and 9. When calibrated and operated within the guidance of ETSI TR 137 941 [i.27] the two methods are applicable and selected due to availability of test facility:

- 1) Place the AAS BS at the positioner.
- 2) Align the coordinate system orientation (D9.2) of the AAS BS with the test system.
- 3) The measurement devices characteristics shall be:
 - Measurement filter bandwidth: defined in clause 6.7.3.5 in ETSI TS 137 145-2 [3].
 - Detection mode: true RMS.
- 4) For single carrier operation, set the AAS BS to transmit according to the applicable test configuration in clause 5 using the corresponding test model(s) in ETSI TS 137 145-2 [3], clause 4.12.2 at *rated carrier TRP* ($P_{\text{Rated,c,TRP}}$).
 For an AAS BS capable of multi-carrier and/or CA operation use the applicable test signal configuration and corresponding power setting specified in ETSI TS 137 145-2 [3], clause 4.11.
- 5) Orient the positioner (and BS) in order that the direction to be tested aligns with the test antenna such that measurements to determine TRP can be performed (see annex F in ETSI TS 137 145-2 [3]).
- 6) Measure the absolute total power of the assigned channel frequency and the (adjacent channel frequency).

- 7) Repeat steps 6 and 7 for all directions in the appropriate TRP measurement grid needed for $TRP_{Estimate}$ for each of the assigned channel frequency and the adjacent channel frequency (see annex F in ETSI TS 137 145-2 [3]).
- 8) Calculate $TRP_{Estimate}$ for the absolute *total radiated power* of the wanted channel and the adjacent channel and the ACLR estimate using the measurements made in step 7.
- 9) Calculate relative ACLR estimate.

NOTE: ACLR is calculated by the ratio of the absolute TRP of the assigned channel frequency and the absolute TRP of the adjacent frequency channel.

5.3.15.3.2 MSR

- 1) For E-UTRA and NR, measure OTA ACLR:
 - Outside the Base Station RF Bandwidth edges.
 - Inside *sub-block gap* for *non-contiguous spectrum* operation, as specified in clause 4.3.15.2.3.1 and clause 4.3.15.2.3.4.
 - Inside *Inter RF Bandwidth gap* for multi-band operation.
- 2) For UTRA FDD, measure ACLR inside *sub-block gap* or *Inter RF Bandwidth gap* as specified in clause 4.3.15.2.3.2.
- 3) Measure CA CLR inside *sub-block gap* or the *Inter RF Bandwidth gap* as specified in clause 4.3.15.2.3.3.

In addition, for *multi-band RIB*, the following steps shall apply:

- 4) For *multi-band RIB* and single band tests, repeat the steps above per involved band where single band test configurations and test models shall apply with no carrier activated in the other band.

5.3.15.3.3 UTRA FDD

- 1) Measure OTA ACLR for 5 MHz and 10 MHz offsets both side of channel frequency. In multiple carrier case only offset frequencies below the lowest and above the *highest carrier* frequency used shall be measured.
- 2) For the OTA ACLR requirement applied inside *sub-block gap* for *non-contiguous spectrum* operation or inside *Inter RF Bandwidth gap* for multi-band operation:
 - a) Measure OTA ACLR inside *sub-block gap* or *Inter RF Bandwidth gap* as specified in clause 4.3.15.2.3.5, if applicable.
 - b) Measure OTA CA CLR inside *sub-block gap* or *Inter RF Bandwidth gap* as specified in clause 4.3.15.2.3.6, if applicable.

In addition, for *multi-band RIB*, the following steps shall apply:

- 3) For *multi-band RIB* and single band tests, repeat the steps above per involved band where single band test configurations and test models shall apply with no carrier activated in the other band.

5.3.15.3.4 E-UTRA

- 1) Measure OTA ACLR for the frequency offsets both side of channel frequency as specified in table 4.3.15.2.3.7-1 (Paired spectrum case) or table 4.3.15.2.3.7-2 (Unpaired spectrum case) respectively. In multiple carrier case only offset frequencies below the lowest and above the *highest carrier* frequency used shall be measured.
- 2) For the OTA ACLR requirement applied inside *sub-block gap* for *non-contiguous spectrum* operation, or inside *Inter RF Bandwidth gap* for multi-band operation:
 - a) Measure OTA ACLR inside *sub-block gap* or *Inter RF Bandwidth gap* as specified in clause 4.3.15.2.3.7, if applicable.

b) Measure OTA CACLR inside *sub-block gap* or *Inter RF Bandwidth gap* as specified in clause 4.3.15.2.3.8, if applicable.

3) Repeat the test with the channel set-up according to E- TM1.2 in ETSI TS 137 145-2 [3], clause 4.12.2.

In addition, for *multi-band RIB(s)*, the following steps shall apply:

4) For *multi-band RIB* and single band tests, repeat the steps above per involved band where single band test configurations and test models shall apply with no carrier activated in the other band.

5.3.15.4 Test requirement

The results shall fulfil the conditions and limits of clause 4.3.15.2.

5.3.16 OTA transmitter spurious emissions

5.3.16.1 General

OTA transmitter spurious emissions tests aim to verify that radiated spurious emissions are within the:

- general spurious emission limits (measured as TRP at the RIB);
- limits for protection of own BS receiver (measured conducted at output of CLTA);
- limits for co-existence with other systems (measured as TRP at the RIB).

5.3.16.2 General spurious emissions

5.3.16.2.1 General

The test purpose is to verify if the radiated spurious emissions from the BS at the RIB are within the specified limits.

5.3.16.2.2 Initial conditions

Test environment:

- normal, see ETSI TS 137 145-2 [3], clause G.2.

RF channels to be tested for single carrier:

- B when testing from 30 MHz to $F_{DL_low} - \Delta f_{OBUE}$.
- T when testing from $F_{DL_high} + \Delta f_{OBUE}$ to 12,75 GHz (or to 5th harmonic).

Base Station RF bandwidth positions to be tested: in single-band operation, see clause 5.3.1:

- B_{RFBW} when testing from 30 MHz to $F_{DL_low} - \Delta f_{OBUE}$.
- T_{RFBW} when testing from $F_{DL_high} + \Delta f_{OBUE}$ to 12,75 GHz (or 5th harmonic).

Base Station RF bandwidth positions to be tested in multi-band operation, see clause 5.3.1:

- $B_{RFBW_T_{RFBW}}$ when testing from 30 MHz to $F_{DL_B_{low_low}} - \Delta f_{OBUE}$.
- $B'_{RFBW_T_{RFBW}}$ when testing from $F_{DL_B_{high_high}} + \Delta f_{OBUE}$ to 12,75 GHz (or to 5th harmonic).
- $B_{RFBW_T_{RFBW}}$ and $B'_{RFBW_T_{RFBW}}$ when testing from $F_{DL_B_{low_high}} + \Delta f_{OBUE}$ to $F_{DL_B_{high_low}} - \Delta f_{OBUE}$.

Directions to be tested:

- As the requirement is TRP the beam pattern(s) may be set up to optimize the TRP measurement procedure (see ETSI TS 137 145-2 [3], annex F).

5.3.16.2.3 Procedure

5.3.16.2.3.1 General procedure

The general procedure steps apply to the procedures for both TRP and EIRP measurements:

- 1) Place the AAS BS at the positioner.
- 2) Align the coordinate system orientation (D9.2) of the AAS BS with the test system.
- 3) Measurements shall use a *measurement bandwidth* in accordance to the conditions in clause 4.3.16.2.1.
- 4) The measurement device characteristics shall be:
 - Detection mode: True RMS.
- 5) Set the AAS BS to transmit:
 - a) For MSR:
 - Set the RIB to transmit maximum power according to the applicable test configuration using the corresponding test models or set of physical channels, see clause 5.3.1.
 - b) For UTRA:
 - For a RIB capable of single carrier operation only, set the RIB to transmit a signal according to TM1, clause ETSI TS 137 145-2 [3], clause 4.12.2, at the *rated carrier TRP*, $P_{\text{rated,c,TRP}}$.
 - For a RIB capable of multi-carrier operation, set the set the RIB to transmit according to TM1 on all carriers configured using the applicable test configuration and corresponding power setting specified in ETSI TS 137 145-2 [3], clause 4.11.
 - c) For E-UTRA:
 - RIB capable of single carrier operation only, set the RIB to transmit a signal according to E-TM1.1 in ETSI TS 137 145-2 [3], clause 4.12.2, at *rated carrier TRP*, $P_{\text{rated,c,TRP}}$.
 - For a RIB capable of multi-carrier and/or CA operation, set the set the RIB to transmit according to E-TM1.1 on all carriers configured using the applicable test configuration and corresponding power setting specified in ETSI TS 137 145-2 [3], clause 4.11.

5.3.16.2.3.2 Procedure for TRP measurements

The following procedure for measuring TRP is based on the directional power measurements as described in annex F in ETSI TS 137 145-2 [3]. An alternative method to measure TRP is to use a characterized and calibrated reverberation chamber if so follow steps 1, 3, 4, 5 in clause 5.3.16.2.3.1 and steps 2 and 5 below. When calibrated and operated within the guidance of ETSI TR 137 941 [i.27] the two methods are applicable and selected due to availability of test facility:

- 1) Orient the positioner (and BS) in order that the direction to be tested aligns with the test antenna such that measurements to determine TRP can be performed.
- 2) Measure the emission at the specified frequencies with specified *measurement bandwidth*
- 3) Repeat steps 6 and 7 for all directions in the appropriate TRP measurement grid needed for full TRP estimation.

NOTE 1: The TRP measurement grid may not be the same for all measurement frequencies.

NOTE 2: The frequency sweep or the TRP measurement grid sweep may be done in any order.

- 4) Calculate TRP at each specified frequency using the directional measurements.

In addition, for *multi-band RIB(s)*, the following steps shall apply:

- 5) For *multi-band RIBs* and single band tests, repeat the steps above per involved band where single band test configurations and test models shall apply with no carrier activated in the other band.

5.3.16.2.3.3 Procedure for EIRP measurements

- 1) Identify the direction of maximum EIRP of spurious emissions, at the specified frequencies with specified *measurement bandwidth*.
- 2) Measure $EIRP_{p1}$ and $EIRP_{p2}$ for any two orthogonal polarizations (denoted p1 and p2) and calculate:

$$EIRP = EIRP_{p1} + EIRP_{p2}.$$

In addition, for *multi-band RIB(s)*, the following steps shall apply:

- 3) For *multi-band RIBs* and single band tests, repeat the steps above per involved band where single band test configurations and test models shall apply with no carrier activated in the other band.

5.3.16.2.4 Test requirement

The results shall fulfil the conditions and limits of clause 4.3.16.2.1.

5.3.16.3 Protection of the *BS receiver*

5.3.16.3.1 General

This requirement shall be applied for FDD operation in order to prevent the receivers of own or a different BS of the same band being desensitized by emissions from a *OTA AAS BS*.

The requirement is a co-location requirement, the power levels specified at the CLTA output(s).

5.3.16.3.2 Initial conditions

Test environment:

- Normal; see ETSI TS 137 145-2 [3], clause G.2.

RF channels to be tested for Single Carrier (SC):

- M; see clause 5.3.1.

Base Station RF Bandwidth positions to be tested for Multi-Carrier (MC):

- M_{RFBW} for *single-band RIB*; $B_{RFBW_T_{RFBW}}$ and $B'_{RFBW_T_{RFBW}}$ for *multi-band RIB*, see clause 5.3.1.

In addition, for *multi-band RIB*:

- For $B_{RFBW_T_{RFBW}}$, co-location spurious emission testing above the highest *operating band* may be omitted.
- For $B'_{RFBW_T_{RFBW}}$, co-location spurious emission testing below the lowest *operating band* may be omitted.

Directions to be tested:

- The requirement is specified as co-location requirement. For general description of co-location requirements, refer to ETSI TS 137 145-2 [3], clause 4.15.

The co-location spurious emission is measured at the CLTA conducted output(s).

5.3.16.3.3 Procedure

- 1) Select a CLTA according to parameters given in ETSI TS 137 145-2 [3], table 4.15.2.2-1 and place the CLTA according to parameters given in ETSI TS 137 145-2 [3], table 4.15.2.3-1.
- 2) Several CLTAs are required to cover the whole co-location spurious emission frequency ranges.
- 3) The test antenna shall be dual (or single) polarized with the same frequency range as the *AAS BS* for co-location spurious emission test case.

4) Connect test antenna and CLTA to the measurement equipment.

NOTE: Example of measurement test setup is in ETSI TS 137 145-2 [3], clause D.1.4.

5) OTA co-location spurious emission is measured at the CLTA conducted output(s).

6) The measurement device (signal analyser) characteristics shall be:

- Detection mode: True RMS.

7) Set the AAS BS to transmit:

a) For MSR:

- Set the AAS BS to transmit maximum power according to the applicable test configuration using the corresponding test models or set of physical channels, see clause 5.3.1.

b) For UTRA FDD:

- For a AAS BS capable of single carrier operation only, set the AAS BS to transmit full maximum power according to TM1, ETSI TS 137 145-2 [3], clause 4.12.2, at the *rated carrier TRP*, $P_{\text{Rated,c,TRP}}$.
- For a AAS BS capable of multi-carrier operation, set the AAS BS to transmit maximum power according to TM1 on all carriers configured using the applicable test configuration and corresponding power setting specified in ETSI TS 137 145-2 [3], clause 4.11.

c) For E-UTRA:

- For AAS BS capable of single carrier operation only, set the AAS BS to transmit maximum power according to E-TM1.1 in ETSI TS 137 145-2 [3], clause 4.12.2, at *rated carrier TRP*, $P_{\text{Rated,c,TRP}}$.
- For a AAS BS capable of multi-carrier and/or CA operation, set the AAS BS to transmit maximum power according to E-TM1.1 on all carriers configured using the applicable test configuration and corresponding power setting specified in ETSI TS 137 145-2 [3], clause 4.11.

8) Measure the emission at the specified frequencies with specified *measurement bandwidth*.

In addition, for *multi-band RIB*, the following steps shall apply:

9) For *multi-band RIB* and single band tests, repeat the steps above per involved band where single band test configurations and test models shall apply with no carrier activated in the other band.

5.3.16.3.4 Test requirement

The results shall fulfil the conditions and limits of clause 4.3.16.2.2.

5.3.16.4 Co-existence with other systems

5.3.16.4.1 General

These requirements shall be applied for the protection of system operating in frequency ranges other than the BS *downlink operating band*.

5.3.16.4.2 Initial conditions

Test environment:

- Normal, see ETSI TS 137 145-2 [3], clause G.2.

RF channels to be tested for single carrier:

- B when testing from 30 MHz to $F_{\text{DL,low}} - \Delta f_{\text{OBUE}}$.
- T when testing from $F_{\text{DL,high}} + \Delta f_{\text{OBUE}}$ to 12,75 GHz (or to 5th harmonic).

Base Station RF bandwidth positions to be tested: in single-band operation, see clause 5.3.1:

- B_{RFBW} when testing from 30 MHz to $F_{\text{DL_low}} - \Delta f_{\text{OBUE}}$.
- T_{RFBW} when testing from $F_{\text{DL_high}} + \Delta f_{\text{OBUE}}$ to 12,75 GHz (or to 5th harmonic).

Base Station RF bandwidth positions to be tested in multi-band operation, see clause 5.3.1:

- $B_{\text{RFBW}}T_{\text{RFBW}}$ when testing from 30 MHz to $F_{\text{DL_Blow_low}} - \Delta f_{\text{OBUE}}$.
- $B'_{\text{RFBW}}T_{\text{RFBW}}$ when testing from $F_{\text{DL_Bhigh_high}} + \Delta f_{\text{OBUE}}$ to 12,75 GHz (or to 5th harmonic).
- $B_{\text{RFBW}}T_{\text{RFBW}}$ and $B'_{\text{RFBW}}T_{\text{RFBW}}$ when testing from $F_{\text{DL_Blow_high}} + \Delta f_{\text{OBUE}}$ to $F_{\text{DL_Bhigh_low}} - \Delta f_{\text{OBUE}}$.

Directions to be tested:

- As the requirement is TRP the beam pattern(s) may be set up to optimize the TRP measurement procedure (see ETSI TS 137 145-2 [3], annex F).

5.3.16.4.3 Procedure

The following procedure for measuring TRP is based on the directional power measurements as described in in annex F in ETSI TS 137 145-2 [3]. An alternative method to measure TRP is to use a characterized and calibrated reverberation chamber if so follow steps 1, 3, 4, 5, 7 and 10. When calibrated and operated within the guidance of ETSI TR 137 941 [i.27] the two methods are applicable and selected due to availability of test facility:

- 1) Place the AAS BS at the positioner.
- 2) Align the coordinate system orientation (D9.2) of the AAS BS with the test system.
- 3) Measurements shall use a *measurement bandwidth* in accordance to the conditions in clause 4.3.16.2.3.
- 4) The measurement device characteristics shall be:
 - Detection mode: True RMS.
- 5) Set the AAS BS to transmit:
 - a) For MSR:
 - Set the RIB to transmit maximum power according to the applicable test configuration using the corresponding test models or set of physical channels, see clause 5.3.1.
 - b) For UTRA:
 - For a RIB capable of single carrier operation only, set the RIB to transmit a signal according to TM1, ETSI TS 137 145-2 [3], clause 4.12.2, at the *rated carrier TRP*, $P_{\text{rated,c,TRP}}$.
 - For a RIB capable of multi-carrier operation, set the set the RIB to transmit according to TM1 on all carriers configured using the applicable test configuration and corresponding power setting specified in ETSI TS 137 145-2 [3], clause 4.11.
 - c) For E-UTRA:
 - RIB capable of single carrier operation only, set the RIB to transmit a signal according to E-TM1.1 in ETSI TS 137 145-2 [3], clause 4.12.2, at *rated carrier TRP* $P_{\text{rated,c,TRP}}$.
 - For a RIB capable of multi-carrier and/or CA operation, set the set the RIB to transmit according to E-TM1.1 on all carriers configured using the applicable test configuration and corresponding power setting specified in ETSI TS 137 145-2 [3], clause 4.11.
- 6) Orient the positioner (and BS) in order that the direction to be tested aligns with the test antenna such that measurements to determine TRP can be performed (see ETSI TS 137 145-2 [3], annex F).
- 7) Measure the emission at the specified frequencies with specified *measurement bandwidth*

- 8) Repeat steps 6 and 7 for all directions in the appropriate TRP measurement grid needed for full TRP estimation (see ETSI TS 137 145-2 [3], annex F).

NOTE 1: The TRP measurement grid may not be the same for all measurement frequencies.

NOTE 2: the frequency sweep or the TRP measurement grid sweep may be done in any order.

- 9) Calculate TRP at each specified frequency using the directional measurements.

In addition, for *multi-band RIB(s)*, the following steps shall apply:

- 10) For *multi-band RIBs* and single band tests, repeat the steps above per involved band where single band test configurations and test models shall apply with no carrier activated in the other band.

5.3.16.4.4 Test requirement

The results shall fulfil the conditions and limits of clause 4.3.16.3.

5.3.17 Radiated transmit power

5.3.17.1 General

The test purpose is to verify the accuracy of the *maximum carrier EIRP*, $P_{\max,c,EIRP}$, across the frequency range for all *RIBs*.

5.3.17.2 Initial conditions

Test environment:

- Normal; see ETSI TS 137 145-2 [3], clause G.2.
- Extreme; see ETSI TS 137 145-2 [3], clauses G.3 and G.5. Applies only for *OTA AAS BS*.

RF bandwidth positions to be tested:

- B_{RFBW} , M_{RFBW} and T_{RFBW} in single-band operation, see clause 5.3.1.
- $B_{RFBW_T_{RFBW}}$ and $B'_{RFBW_T_{RFBW}}$ in multi-band operation, see clause 5.3.1.

Directions to be tested:

- Reference beam direction pair D9.7.
- Maximum steering directions, D9.9.

Beams to be tested:

- the beam with the highest rated beam EIRP (D9.10); or
- the beams with highest rated beam EIRP, $P_{\text{rated},c,FBW\text{low}}$ (D11.33) and $P_{\text{rated},c,FBW\text{high}}$ (D11.34), if these are provided.

Under extreme test environment, for *OTA AAS BS* only, it is sufficient to test on one ARFCN, UARFCN or EARFCN or NR-ARFCN or one *Base Station RF Bandwidth* position, and with one applicable test configuration defined in clauses 4.11 and 5 in ETSI TS 137 145-2 [3]. Direction to be tested is only at *reference beam direction pair* (D9.7). Testing shall be performed under extreme power supply conditions, as defined in clause G.5 of ETSI TS 137 145-2 [3].

NOTE: Tests under extreme power supply conditions also test extreme temperature.

5.3.17.3 Procedure

- 1) Place the AAS BS at the positioner.
- 2) Align the coordinate system orientation (D9.2) of the AAS BS with the test system.

- 3) Orient the positioner (and BS) in order that the direction to be tested aligns with the test antenna.
- 4) Configure the *beam peak direction* of the AAS BS according to the *beam direction pair*.
- 5) Set the base station to transmit according to the applicable test configuration in clause 5 using the corresponding test model(s) in ETSI TS 137 145-2 [3], clause 4.12.2.

In addition, for an AAS BS capable of multi-carrier and/or CA operation use the applicable test signal configuration and corresponding power setting specified in ETSI TS 137 145-2 [3], clause 4.11.

- 6) Measure EIRP for any two orthogonal polarizations (denoted p1 and p2) and calculate total radiated transmit power for particular *beam direction pair* as $EIRP = EIRP_{p1} + EIRP_{p2}$.
- 7) Test steps 3 to 6 are repeated for all beams (see ETSI TS 137 145-2 [3], tables 4.10-1, D9.3) and their *reference beam direction pairs* and *maximum steering directions* (see ETSI TS 137 145-2 [3], tables 4.10-1, D9.7 and D9.11).

For multi-band capable AAS BS and single band tests, repeat the steps above per involved band where single band test configurations and test models shall apply with no carriers activated in the other band.

- 8) For extreme test environment tests the methods in clause G in ETSI TS 137 145-2 [3] may be used where a representative power measurement is taken in both normal test environment ($P_{\max, \text{sample}, \text{nom}}$) and extreme test environment ($P_{\max, \text{sample}, \text{ext}}$) and the delta (Δ_{sample}) is added to the measurement from step 6 such that $P_{\max, \text{c}, \text{EIRP}, \text{extreme}} = P_{\max, \text{c}, \text{EIRP}} + \Delta_{\text{sample}}$.

5.3.17.4 Test requirement

The results shall fulfil the conditions and limits of clause 4.3.17.2.

5.3.18 OTA Maximum output power

5.3.18.1 General

The test purpose is to verify the accuracy of the *maximum carrier TRP* ($P_{\max, \text{c}, \text{TRP}}$) across the frequency range for all *RIBs*.

5.3.18.2 Initial conditions

Test environment:

- Normal; see ETSI TS 137 145-2 [3], clause G.2.

Base Station RF bandwidth positions to be tested:

- B_{RFBW} , M_{RFBW} and T_{RFBW} in single-band operation, see clause 5.3.1.
- $B_{\text{RFBW}} \cdot T_{\text{RFBW}}$ and $B'_{\text{RFBW}} \cdot T_{\text{RFBW}}$ in multi-band operation, see clause 5.3.1.

As the requirement is TRP the beam pattern(s) may be set up to optimize the TRP measurement procedure (see ETSI TS 137 145-2 [3], annex F).

5.3.18.3 Procedure

The following procedure for measuring TRP is based on the directional power measurements as described in ETSI TS 137 145-2 [3], annex F. An alternative method to measure TRP is to use a characterized and calibrated reverberation chamber if so follow steps 1, 4, 5, and 7. When calibrated and operated within the guidance of ETSI TR 137 941 [i.27] the two methods are applicable and selected due to availability of test facility:

- 1) Place the AAS BS at the positioner.
- 2) Align the coordinate system orientation (D9.2) of the AAS BS with the test system.

- 3) Configure the AAS BS such that the *beam peak direction(s)* applied during the power measurement step 6 are consistent with the grid and measurement approach for the TRP test.
- 4) Set the AAS BS to transmit according to the applicable test configuration in clause 5 using the corresponding test model(s) in ETSI TS 137 145-2 [3], clause 4.12.2.

In addition, for an AAS BS capable of multi-carrier and/or CA operation use the applicable test signal configuration and corresponding power setting specified in ETSI TS 137 145-2 [3], clause 4.11.

- 5) Orient the positioner (and BS) in order that the direction to be tested aligns with the test antenna such that measurements to determine TRP can be performed (see ETSI TS 137 145-2 [3], annex F).
- 6) Measure the EIRP for any two orthogonal polarizations (denoted p1 and p2) and calculate total radiated transmit power for particular *beam direction pair* as $EIRP = EIRP_{p1} + EIRP_{p2}$.

If the test chamber is a reverberation chamber measure TRP directly.

- 7) Measure EIRP for any two orthogonal polarizations (denoted p1 and p2) and calculate total radiated transmit power for particular *beam direction pair* as $EIRP = EIRP_{p1} + EIRP_{p2}$.
- 8) Calculate TRP using the power measurements.

For multi-band capable AAS BS and single band tests, repeat the steps above per involved band where single band test configurations and test models shall apply with no carriers activated in the other band.

5.3.18.4 Test requirement

The results shall fulfil the conditions and limits of clause 4.3.18.2.

5.3.19 OTA transmitter intermodulation

5.3.19.1 General

The test purpose is to verify the ability of the transmitter units associated with the *RIB* under test to restrict the generation of intermodulation products in its nonlinear elements caused by presence of the wanted signal and an interfering signal reaching the transmitter unit via the RDN and antenna array from a co-located base station to below specified levels.

5.3.19.2 Initial conditions

Test environment:

- Normal; see clause G.2 in ETSI TS 137 145-2 [3].

RF channels to be tested for single carrier:

- M; see clause 5.3.1.

Base Station RF Bandwidth positions to be tested for multi-carrier:

- M_{RFBW} in *single-band RIB*, see clause 5.3.1;
- $B_{RFBW_T_{RFBW}}$ and $B'_{RFBW_T_{RFBW}}$ in *multi-band RIB*, see clause 5.3.1.

In addition, for *multi-band RIB*:

- For $B_{RFBW_T_{RFBW}}$, emission testing above the highest *operating band* may be omitted.
- For $B'_{RFBW_T_{RFBW}}$, emission testing below the lowest *operating band* may be omitted.

Directions to be tested:

- As the requirement is based on TRP the beam pattern(s) may be set up to optimize the TRP measurement procedure (see annex F in ETSI TS 137 145-2 [3]).

5.3.19.3 Procedure

- 1) Select a CLTA according to parameters given in table 4.15.2.2-1 in ETSI TS 137 145-2 [3].
- 2) Place the CLTA according to parameters given in table 4.15.2.3-1 in ETSI TS 137 145-2 [3].
- 3) The test antenna(s) shall be dual (or single) polarized covering the same frequency range as the AAS BS and the emission frequencies.
- 4) Several test antennas are required to cover both the AAS BS and the whole emission frequency range.
- 5) Connect the test antenna and CLTA to the measurement equipment.

NOTE 1: Example of measurement test setup is in clause D.1.5, figures D.1.5-1 in ETSI TS 137 145-2 [3].

- 6) During the OTA emission measurements at the test antenna conducted output(s), both AAS BS and CLTA are rotated around same axis.
- 7) The OTA unwanted emissions measurement method shall be TRP, according to the procedure described in annex F in ETSI TS 137 145-2 [3].
- 8) The measurement device (signal analyser) characteristics shall be:
 - Detection mode: True RMS.
- 9) Set the AAS BS to transmit:
 - a) For MSR:
 - Set the AAS BS to transmit maximum power according to the applicable test configuration using the corresponding test models or set of physical channels, see clause 5.3.1.
 - b) For UTRA FDD:
 - For a AAS BS capable of single carrier operation only, set the AAS BS to transmit maximum power according to TM1 (see ETSI TS 137 145-2 [3], clause 4.12.2), at the *rated carrier TRP*, $P_{\text{Rated,c,TRP}}$.
 - For a AAS BS capable of multi-carrier operation, set the AAS BS to transmit maximum power according to TM1 on all carriers configured using the applicable test configuration and corresponding power setting specified in clause 4.11 in ETSI TS 137 145-2 [3].
 - c) For E-UTRA:
 - For AAS BS capable of single carrier operation only, set the AAS BS to transmit maximum power according to E-TM1.1 (see ETSI TS 137 145-2 [3], clause 4.12.2), at *rated carrier TRP*, $P_{\text{Rated,c,TRP}}$.
 - For a AAS BS capable of multi-carrier and/or CA operation, set the AAS BS to transmit maximum power according to E-TM1.1 on all carriers configured using the applicable test configuration and corresponding power setting specified in clause 4.11 in ETSI TS 137 145-2 [3].
- 10) Generate the interfering signal:
 - a) For MSR:
 - Using E-TM1.1 (see ETSI TS 137 145-2 [3], clause 4.12.2), with 5 MHz *channel bandwidth*, at a centre frequency offset according to the conditions in table 4.3.19.2.1.1-1, but exclude interfering frequencies that are outside of the allocated downlink operating band or interfering frequencies that are not completely within the *sub-block gap* or within the *Inter RF Bandwidth gap*.
 - b) For UTRA FDD:
 - In accordance to TM1 (see clause 4.12.2 in ETSI TS 137 145-2 [3]) with a frequency offset according to the conditions of table 4.3.19.2.2.1-1, but exclude interfering signal frequencies that are outside of the allocated downlink *operating band* or interfering signal frequencies that are not completely within the *sub-block gap* or within the *Inter RF Bandwidth gap*.

- c) For E-UTRA:
- According to E-TM1.1 (see ETSI TS 137 145-2 [3], clause 4.12.2), with 5 MHz *channel bandwidth* and a centre frequency offset according to the conditions of table 4.3.19.2.3.1-1, but exclude interfering frequencies that are outside of the allocated downlink *operating band* or interfering frequencies that are not completely within the *sub-block gap* or within the *Inter RF Bandwidth gap*.
- 11) Connect the interfering signal to the CLTA input interfaces, equally dividing the power among supported polarizations. Adjust the interfering signal level at the CLTA conducted input(s) as defined in:
- a) For MSR:
- i. General limit table 4.3.19.2.1.1-1.
 - ii. Additional limit (BC1 and BC2) table 4.3.19.2.1.2-1.
- b) For UTRA FDD:
- i. General limit table 4.3.19.2.2.1-1.
- c) For E-UTRA:
- i. General limit table 4.3.19.2.3.1-1.
- 12) If the interfering signal is applicable according to clause 5 in ETSI TS 137 145-2 [3], perform the unwanted emission tests specified in clauses 5.3.15 (OTA ACLR), 5.3.14 (OTA SEM) and 5.3.13 (OTA OBUE), for all third and fifth order intermodulation products which appear in the frequency ranges defined in clauses 4.3.15, 4.3.14 and 4.3.13. The width of the intermodulation products shall be taken into account.
- 13) If the interfering signal is applicable according to clause 5 in ETSI TS 137 145-2 [3], perform the transmitter spurious emissions test as specified in clause 5.3.15 (OTA spurious emission), for all third and fifth order intermodulation products which appear in the frequency ranges defined in clause 4.3.16. The width of the intermodulation products shall be taken into account.
- 14) Verify that the emission level does not exceed the limit in clause 4.3.19.2 with the exception of interfering signal frequencies.
- 15) Repeat the test for the remaining interfering signal centre frequency offsets according to the conditions of:
- a) For MSR:
- i. General limit table 4.3.19.2.1.1-1.
 - ii. Additional limit (BC1 and BC2) table 4.3.19.2.1.2-1.
- b) For UTRA FDD:
- i. General limit table 4.3.19.2.2.1-1 .
- c) For E-UTRA:
- i. General limit table 4.3.19.2.3.1-1.
- 16) Repeat the test for the remaining interfering signals defined in clause 5 in ETSI TS 137 145-2 [3] for OTA ACLR, OTA SEM, OTA OBUE and OTA spurious emission.

In addition, for *multi-band AAS BS*, the following steps shall apply:

- 17) For *multi-band AAS BS* and single band tests, repeat the steps above per involved band where single band test configurations and test models shall apply with no carrier activated in the other band.

NOTE 2: The third order intermodulation products are centred at $2F1 \pm F2$ and $2F2 \pm F1$. The fifth order intermodulation products are centred at $3F1 \pm 2F2$, $3F2 \pm 2F1$, $4F1 \pm F2$, and $4F2 \pm F1$ where $F1$ represents the test signal centre frequency or centre frequency of each *sub-block* and $F2$ represents the interfering signal centre frequency. The widths of intermodulation products are:

$$(n \times BW_{F1} + m \times BW_{F2}) \text{ for the } nF1 \pm mF2 \text{ products;}$$

$(n \times BW_{F2} + m \times BW_{F1})$ for the $nF2 \pm mF1$ products;

where BW_{F1} represents the test signal RF bandwidth or *channel bandwidth* in case of single carrier, or *sub-block* bandwidth, and BW_{F2} represents the interfering signal bandwidth.

NOTE 3: During the conformance test the interfering signal can be applied on one side of the wanted signal, while the transmitter intermodulation emission is measured only on the opposite side of the wanted signal. This applies for intermodulation products which are within the *operating band* or OBUE region.

5.3.19.4 Test requirement

The results shall fulfil the conditions and limits of clause 4.3.19.2.

5.3.20 OTA receiver spurious emissions

5.3.20.1 General

The test purpose is to verify if the receiver radiated spurious emissions from the BS at the RIB are within the specified limits.

5.3.20.2 Initial conditions

Test environment:

- Normal; see ETSI TS 137 145-2 [3], clause G.2.

RF channels to be tested for single carrier:

- M; see clause 5.3.1.

Base Station RF bandwidth positions to be tested in single-band operation:

- M_{RFBW} , see clause 5.3.1.

Base Station RF bandwidth positions to be tested in multi-band operation, see clause 5.3.1:

- $B_{RFBW_T'_{RFBW}}$ when testing from 30 MHz to $F_{DL_Blow_low} - \Delta f_{OBUE}$
- $B'_{RFBW_T_{RFBW}}$ when testing from $F_{DL_Bhigh_high} + \Delta f_{OBUE}$ to 12,75 GHz (or to 5th harmonic)
- $B_{RFBW_T'_{RFBW}}$ and $B'_{RFBW_T_{RFBW}}$ when testing from $F_{DL_Blow_high} + \Delta f_{OBUE}$ to $F_{DL_Bhigh_low} - \Delta f_{OBUE}$

Directions to be tested:

- Not applicable as Rx only TRP measurement.

5.3.20.3 Procedure

The following procedure for measuring TRP is based on the directional power measurements as described in ETSI TS 137 145-2 [3], annex F. An alternative method to measure TRP is to use a characterized and calibrated reverberation chamber if so follow steps 1, 3, 4, 5, 7 and 10. When calibrated and operated within the guidance of ETSI TR 137 941 [i.27] the two methods are applicable and selected due to availability of test facility:

- 1) Place the AAS BS at the positioner.
- 2) Align the coordinate system orientation (D9.2) of the AAS BS with the test system.
- 3) Measurements shall use a *measurement bandwidth* in accordance to the conditions in clause 4.3.20.2.
- 4) The measurement device characteristics shall be:
 - Detection mode: True RMS.

- 5) Set the TDD AAS BS to receive only.
- 6) Orient the positioner (and BS) in order that the direction to be tested aligns with the test antenna such that measurements to determine TRP can be performed (see ETSI TS 137 145-2 [3], annex F).
- 7) Measure the emission at the specified frequencies with specified *measurement bandwidth*.
- 8) Repeat steps 6 and 9 for all directions in the appropriate TRP measurement grid needed for full TRP estimation (see ETSI TS 137 145-2 [3], annex F).

NOTE 1: The TRP measurement grid may not be the same for all measurement frequencies.

NOTE 2: The frequency sweep or the TRP measurement grid sweep may be done in any order.

- 9) Calculate TRP at each specified frequency using the directional measurements.

In addition, for *multi-band RIB(s)*, the following steps shall apply:

- 10) For *multi-band RIBs* and single band tests, repeat the steps above per involved band where single band test configurations and test models shall apply with no carrier activated in the other band.

5.3.20.4 Test requirement

The results shall fulfil the conditions and limits of clause 4.3.20.2.

5.3.21 OTA blocking

5.3.21.1 General

The test verifies the ability of the receiver unit associated with the *RIB* under test to withstand high-level interference from unwanted signals at specified frequency bands, without undue degradation of its sensitivity.

5.3.21.2 Initial conditions

Test environment:

- Normal; see ETSI TS 137 145-2 [3], clause G.2.

RF channels to be tested for Single Carrier (SC):

- M; see clause 5.3.1.

Base Station RF Bandwidth positions to be tested for Multi-Carrier (MC):

- M_{RFBW} for *single-band RIB*, see clause 5.3.1, B_{RFBW_T} and B'_{RFBW_T} for *multi-band RIB*, see clause 5.3.1.

In addition, for *multi-band RIB*:

- For B_{RFBW_T} , blocking testing above the highest *operating band* may be omitted.
- For B'_{RFBW_T} , blocking testing below the lowest *operating band* may be omitted.

Directions to be tested:

- OTA REFSSENS *receiver target reference direction* (see ETSI TS 137 145-2 [3], table 4.10-2, D11.30).

5.3.21.3 Procedure

5.3.21.3.1 General procedure

- 1) Place *AAS BS* and the test antenna(s).

NOTE 1: Example of measurement test setup is in ETSI TS 137 145-2 [3], clause D.2.4.

- 2) Place test antenna(s) in reference direction at far-field distance, aligned in all supported polarizations with the *AAS BS*.

NOTE 2: Example in ETSI TS 137 145-2 [3], table 4.10-1, D10.9 and in ETSI TS 137 145-2 [3], clause D.2.4.

- 3) Connect test antenna(s) to the measurement equipment.

NOTE 3: Example of measurement test setup is in ETSI TS 137 145-2 [3], clause D.2.4.

- 4) The test antenna(s) shall be dual (or single) polarized covering the same frequency ranges as the *AAS BS* and the blocking frequencies. If the test antenna does not cover both the wanted and interfering signal frequencies, separate test antennas for the wanted and interfering signal are required.
- 5) The OTA blocking interferer is injected into the test antenna, with the blocking interferer producing specified interferer field strength level for each supported polarization. The interferer shall be *polarization matched* in-band and the polarization maintained for out-of-band frequencies.
- 6) The *AAS BS* receives the wanted signal and the interfering signal for supported polarization(s), in the reference direction (see ETSI TS 137 145-2 [3], table 4.10-1, D10.9) from the test antenna(s).

5.3.21.3.2 *MSR operation*

- 1) Generate the wanted signal from the test antenna, according to the applicable test configuration (see clause 5 in ETSI TS 137 145-2 [3]) using applicable reference measurement channel to the *RIB* under test.
- 2) Set the transmitter unit(s) associated with the *RIB* under test to transmit in reference direction (see ETSI TS 137 145-2 [3], table 4.10-1, D10.9) with the carrier set-up and power allocation according to the applicable test configuration(s) (see ETSI TS 137 145-2 [3], clause 5).

The transmitter unit(s) associated with the *RIB* under test may be turned off for the out-of-band blocker tests when the frequency of the blocker is such that no IM2 or IM3 products fall inside the bandwidth of the wanted signal.

- 3) Adjust the signal generators to the type of interfering signals, levels and the frequency offsets as specified for general limits in table 4.3.21.2.1-1.

The distance between the test object and test antenna injecting the interfering signal is adjusted when necessary to ensure specified interfering signal level to be received:

- 4) The CW interfering signal shall be swept with a step size of 1 MHz within the specified range.
- 5) Measure the performance of the wanted signal at the receiver unit associated with the *RIB*, as defined in the clause 4.3.21.2.1, for the carriers specified by the test configuration in clause ETSI TS 137 145-2 [3], clause 4.11.
- 6) Repeat for all supported polarizations.

In addition, for *multi-band RIB*, the following steps shall apply:

- 7) For *multi-band RIB* and single band tests, repeat the steps above per involved band where single band test configurations and test models shall apply with no carrier activated in the other band.

5.3.21.3.3 Single RAT UTRA FDD operation

- 1) Generate the wanted signal, from the test antenna, according to the applicable test configuration (see clause 5) using applicable reference measurement channel to the *RIB* under test as shown in ETSI TS 125 141 [7], clause A.2.1.

- 2) Set the transmitter unit(s) associated with the *RIB* under test to transmit in reference direction (see ETSI TS 137 145-2 [3], table 4.10-1, D10.9) with the carrier set-up and power allocation according to the applicable test configuration(s) (see ETSI TS 137 145-2 [3], clause 5).

The transmitter unit(s) associated with the *RIB* under test may be turned off for the out-of-band blocker tests when the frequency of the blocker is such that no IM2 or IM3 products fall inside the bandwidth of the wanted signal.

- 3) Adjust the signal generators to the type of interfering signals and the frequency offsets as specified in tables 4.3.21.2.2-1 and 4.3.21.2.2-2 (in-band and narrowband blocking limits).
- 4) Measure the BER of the wanted signal at the receiver unit associated with the *RIB* under test.
- 5) Repeat for all supported polarizations.

In addition, for *multi-band RIB*, the following steps shall apply:

- 6) For *multi-band RIB* and single band tests, repeat the steps above per involved band where single band test configurations and test models shall apply with no carrier activated in the other band.

5.3.21.3.4 Single RAT E-UTRA operation

- 1) Generate the wanted signal from the test antenna, according to the applicable test configuration (see clause 5) using applicable reference measurement channel to the *RIB* under test as shown in ETSI TS 136 141 [11], clause A.1 in ETSI TS 136 141 [11].
- 2) Set the transmitter unit(s) associated with the *RIB* under test to transmit in reference direction (see ETSI TS 137 145-2 [3], table 4.10-1, D10.9) with the carrier set-up and power allocation according to the applicable test configuration(s) (see ETSI TS 137 145-2 [3], clause 5).

The transmitter unit(s) associated with the *RIB* under test may be turned off for the out-of-band blocker tests when the frequency of the blocker is such that no IM2 or IM3 products fall inside the bandwidth of the wanted signal.

- 3) Adjust the signal generators to the type of interfering signals and the frequency offsets as specified in tables 4.3.21.2.3-1 to 4.3.21.2.3-2 (in-band blocking limits).
- 4) The CW interfering signal shall be swept with a step size of 1 MHz within the specified range.
- 5) Measure the performance of the wanted signal at the receiver unit associated with the *RIB*, as defined in the clause 4.3.21.2.3, for the carriers specified by the test configuration in ETSI TS 137 145-2 [3], clause 4.11.
- 6) Repeat for all supported polarizations.

In addition, for *multi-band RIB*, the following steps shall apply:

- 7) For *multi-band RIB* and single band tests, repeat the steps above per involved band where single band test configurations and test models shall apply with no carrier activated in the other band.

5.3.21.4 Test requirement

The results shall fulfil the conditions and limits of clause 4.3.21.2.

5.3.22 OTA receiver intermodulation

5.3.22.1 General

The test purpose is to verify the ability of the receiver to inhibit the generation of intermodulation products in its non-linear elements caused by the presence of two high-level interfering signals at frequencies with a specific relationship to the frequency of the wanted signal.

5.3.22.2 Initial conditions

Test environment:

- Normal; see clause G.2 in ETSI TS 137 145-2 [3].

RF channels to be tested for single carrier:

- M; see clause 5.3.1.

Base Station RF Bandwidth positions to be tested:

- For *single-band RIB(s)*: M_{RFBW} if ATC4 is applicable; B_{RFBW} and T_{RFBW} for other ATC, see clause 5.31.
- For *multi-band RIB(s)*: $B_{\text{RFBW_T}}'$ and $T_{\text{RFBW_T}}'$, see clause 5.3.1.

Directions to be tested:

- OTA REFSENS *receiver target reference direction* (see table 4.10-20, D11.30 in ETSI TS 137 145-2 [3]).

5.3.22.3 Procedure

5.3.22.3.1 General procedure

The general procedure steps apply to the procedures for all the RATs:

- 1) Place the AAS BS with its coordinate system reference point in the same place as calibrated point in the test system.

NOTE: Example of measurement test setup is in clause D2.6 in ETSI TS 137 145-2 [3].

- 2) Align the coordinate system orientation of the AAS BS with the test system.
- 3) Align the BS with the test antenna in the direction to be tested.
- 4) Align the NR BS to that the wanted signal and interfering signal is *polarization matched* with the test antenna(s).
- 5) Configure the *beam peak direction* of the AAS BS according to *reference beam direction pair* for the appropriate beam identifier.
- 6) Set the AAS BS to transmit the beam(s) of the same operational band and RAT as the OSDD being tested according to the appropriate test configuration in clause 5 in ETSI TS 137 145-2 [3].
- 7) Set the test signal mean power so the calibrated radiated power at the AAS BS Antenna Array coordinate system reference point is as specified as follows:

Set the signal generator for the wanted signal according to the applicable test configuration (see clause 5 in ETSI TS 137 145-2 [3]) using applicable reference measurement channel.

5.3.22.3.2 MSR operation

5.3.22.3.2.1 Procedure for general and narrowband intermodulation

- 1) Adjust the signal generators to the type of interfering signals, levels and the frequency offsets as specified in table 4.3.22.2.1.1-1 and table 4.3.22.2.1.1-2 for general intermodulation requirement, and table 4.3.22.2.1.2-1 and table 4.3.22.2.1.2-2 for narrowband intermodulation requirement.
- 2) Measure the performance of the wanted signal at the receiver under test, as defined in clauses 4.3.22.2.1.1 and 4.3.22.2.1.2, for the carriers specified by the test configuration in ETSI TS 137 145-2 [3], clause 5.
- 3) Repeat for all supported polarizations.

In addition, for *multi-band RIB(s)*, the following steps shall apply:

- 4) For *multi-band RIBs* and single band tests, repeat the steps above per involved band where single band test configurations and test models shall apply with no carrier activated in the other band.

5.3.22.3.3 Single RAT UTRA FDD operation

- 1) Generate the wanted signal (reference signal) with the level specified in table 4.3.22.2.2-1. For a RIB supporting multi-carrier operation, generate the wanted signal according to the applicable test configuration (see clause 4.11 in ETSI TS 137 145-2 [3]) using applicable reference measurement channel. Power settings are specified in table 4.3.22.2.2-1.
- 2) Adjust the signal generators to the type of interfering signals and the frequency offsets as specified in tables 4.3.22.2.2-1 and 4.3.22.2.2-2.
- 3) Set the specified level of interfering signal at the RIB.
- 4) Measure the BER of the wanted signal. For a RIB supporting multi-carrier operation the BER shall be measured for all carriers specified by the test configuration.
- 5) Repeat for all supported polarizations.

In addition, for *multi-band RIB(s)*, the following steps shall apply:

- 6) For *multi-band RIBs* and single band tests, repeat the steps above per involved band where single band test configurations and test models shall apply with no carrier activated in the other band.

5.3.22.3.4 Single RAT E-UTRA operation

- 1) Generate the wanted signal using the applicable test configuration specified in ETSI TS 137 145-2 [3] clause 5, and adjust the signal level to the level specified in table 4.3.22.2.3-1.
- 2) Adjust the signal generators to the type of interfering signals, levels and the frequency offsets as specified in table 4.3.22.2.3-2 for intermodulation requirement and tables 4.3.22.2.3-3, 4.3.22.2.3-4 and 4.3.22.2.3-5 for narrowband intermodulation requirement.
- 3) Adjust the signal generators to obtain the specified level of interfering signal.
- 4) Measure the *throughput* according to annex E of ETSI TS 136 141 [11], for multi-carrier and/or CA operation the *throughput* shall be measured for carriers specified by the test configuration specified in clause 5 in ETSI TS 137 145-2 [3].
- 5) Repeat for all supported polarizations.

In addition, for *multi-band RIB(s)*, the following steps shall apply:

- 6) For *multi-band RIBs* and single band tests, repeat the steps above per involved band where single band test configurations and test models shall apply with no carrier activated in the other band.

5.3.22.4 Test requirement

The results shall fulfil the conditions and limits of clause 4.3.22.2.

5.3.23 OTA Adjacent Channel Selectivity (OTA ACS)

5.3.23.1 General

The test verifies the receiver unit ability to withstand high-level interference from unwanted signals at specified frequency offsets without undue degradation of its sensitivity.

5.3.23.2 Initial conditions

Test environment:

- Normal; see clause G.2 in ETSI TS 137 145-2 [3].

RF channels to be tested for single carrier:

- M; see clause 5.3.1.

Base Station RF Bandwidth positions to be tested for Multi-Carrier (MC):

- M_{RFBW} for *single-band RIB(s)*, see clause 5.3.1.
- $B_{\text{RFBW_T_RFBW}}$ and $B'_{\text{RFBW_T_RFBW}}$ for *multi-band RIB(s)*, see clause 5.3.1.

Directions to be tested:

- OTA minSENS *receiver target reference direction*, see table 4.10-2, D107 in ETSI TS 137 145-2 [3].
- OTA REFSSENS conformance test directions, see table 4.10-2, D11.31 in ETSI TS 137 145-2 [3].

5.3.23.3 Procedure

5.3.23.3.1 General procedure

The general procedure steps apply to the procedures for all the RATs:

- 1) Place the AAS BS with its coordinate system reference point in the same place as calibrated point in the test system.

NOTE: Example of measurement test setup is in clause D.1.1 in ETSI TS 137 145-2 [3].

- 2) Align the coordinate system orientation of the AAS BS with the test system.
- 3) Align the BS with the test antenna in the direction to be tested.
- 4) Align the NR BS to that the wanted signal and interfering signal is *polarization matched* with the test antenna(s).
- 5) Set the test signal mean power so the calibrated radiated power at the AAS BS Antenna Array coordinate system reference point is as specified as follows:
 - a) Set the signal generator for the wanted signal according to the applicable test configuration (see clause 5 in ETSI TS 137 145-2 [3]) using applicable reference measurement channel.

5.3.23.3.2 MSR operation

5.3.23.3.2.1 Procedure for general blocking

- 1) Adjust the signal generators to the type of interfering signal, levels and the frequency offsets as specified in table 4.3.23.2.1.1-1.
- 2) The interfering signal shall be swept with a step size of 1 MHz starting from the minimum offset to the *channel edges* of the wanted signals as specified in table 4.3.23.2.1.1-1.
- 3) Measure the performance of the wanted signal as defined in clause 4.3.23.2, for the carriers specified by the test configuration in clause 4.11 in ETSI TS 137 145-2 [3].
- 4) Repeat for all the specified measurement directions.
- 5) Repeat for all supported polarizations.

In addition, for *multi-band RIB(s)*, the following steps shall apply:

- 6) For *multi-band RIBs* and single band tests, repeat the steps above per involved band where single band test configurations and test models shall apply with no carrier activated in the other band.

5.3.23.3.2 Procedure for narrowband blocking

- 1) Adjust the signal generators to the type of interfering signal, levels and the frequency offsets as specified in table 4.3.23.2.2-1.
- 2) Set-up and sweep the interfering RB centre frequency offset to the *channel edge* of the wanted signal according to table 4.3.23.2.2-1.
- 3) Measure the performance of the wanted signal at the receiver under test, as defined in clause 7.5.5.1, for the carriers specified by the test configuration in clause 4.11 in ETSI TS 137 145-2 [3].
- 4) Repeat for all the specified measurement directions.
- 5) Repeat for all supported polarizations.

In addition, for *multi-band RIB(s)*, the following steps shall apply:

- 6) For *multi-band RIBs* and single band tests, repeat the steps above per involved band where single band test configurations and test models shall apply with no carrier activated in the other band.

5.3.23.3.3 Single RAT UTRA FDD operation

- 1) Generate the wanted signal with the level specified in table 4.3.23.2.2-1 For a RIB supporting multi-carrier operation, generate the wanted signal according to the applicable test configuration (see clause 5) using applicable reference measurement channel to the RIB under test. Power settings are specified in table 4.3.23.2.2-1.
- 2) Set-up the interfering signal at the adjacent channel frequency and specified level of interfering signal at the AAS BS input defined in table 4.3.23.2.2-1. Note that the interfering signal shall have an ACLR of at least 63 dB in order to eliminate the impact of interfering signal adjacent channel leakage power on the ACS measurement.
- 3) Measure the BER of the wanted signal at the receiver under test.
- 4) Repeat for all the specified measurement directions and all supported polarizations.

In addition, for *multi-band RIB(s)*, the following steps shall apply:

- 5) For *multi-band RIBs* and single band tests, repeat the steps above per involved band where single band test configurations and test models shall apply with no carrier activated in the other band.

5.3.23.3.4 Single RAT E-UTRA operation

5.3.23.3.4.1 Procedure for adjacent channel selectivity

- 1) Generate the wanted signal using the applicable test configuration specified in clause 5.3.4 in ETSI TS 137 145-2 [3] and adjust the input level to the level specified in tables 4.3.23.2.3-3 to 4.3.23.2.3-5 for the appropriate *BS class*.
- 2) Set-up the interfering signal at the adjacent channel frequency and adjust the interfering signal level to the level defined in tables 4.3.23.2.3-3 to 4.3.23.2.3-5 for the appropriate *BS class*.
- 3) Measure the *throughput* according to annex E in ETSI TS 136 141 [11], for multi-carrier and/or CA operation the *throughput* shall be measured for carriers specified by the test configuration specified in clause 5.3.4 in ETSI TS 137 145-2 [3].
- 4) Repeat for all the specified measurement directions and all supported polarizations.

In addition, for *multi-band RIB(s)*, the following steps shall apply:

- 5) For *multi-band RIBs* and single band tests, repeat the steps above per involved band where single band test configurations and test models shall apply with no carrier activated in the other band.

5.3.23.3.4.2 Procedure for narrow-band blocking

- 1) Configure the *beam peak direction* of the AAS BS according to *reference beam direction pair* for the appropriate beam identifier.
- 2) For RIB operating E-UTRA FDD capable of single carrier operation only in the *operating band*, set the AAS BS to transmit according to clause 4.12.2 in ETSI TS 137 145-2 [3] at *rated carrier TRP* $P_{\text{Rated,c,TABC}}$.

For a RIB operating E-UTRA FDD capable of multi-carrier and/or CA operation in the *operating band*, set the ASA BS to transmit according to clause 4.12.2 in ETSI TS 137 145-2 [3] on all carriers configured using the applicable test configuration and corresponding power setting specified in clause 5.3.4 in ETSI TS 137 145-2 [3].

- 3) Generate the wanted signal using the applicable test configuration specified in clause 5.3.4 in ETSI TS 137 145-2 [3] and adjust the input level to the level specified in table 4.3.23.2.3-1.
- 4) Adjust the interfering signal level to the level defined in table 4.3.23.2.3-1. Set-up and sweep the interfering RB centre frequency offset to the *channel edge* of the wanted signal according to table 4.3.23.2.3-2.
- 5) Measure the *throughput* according to annex E in ETSI TS 136 141 [11], for multi-carrier and/or CA operation the *throughput* shall be measured for carriers specified by the test configuration specified in clause 5.3.4 in ETSI TS 137 145-2 [3].
- 6) Repeat for all the specified measurement directions and all supported polarizations.

In addition, for *multi-band RIB(s)*, the following steps shall apply:

- 7) For *multi-band RIBs* and single band tests, repeat the steps above per involved band where single band test configurations and test models shall apply with no carrier activated in the other band.

5.3.23.4 Test requirement

The results shall fulfil the conditions and limits of clause 4.3.23.2.

5.3.24 OTA sensitivity

5.3.24.1 General

The test purpose is to verify that the BS can meet the *throughput* requirement for a specified measurement channel at the EIS level and the range of angles of arrival in the OSDD.

5.3.24.2 Initial conditions

Test environment:

- Normal: see ETSI TS 137 145-2 [3], clause G.2.

RF channels to be tested:

- M; see clause 5.3.1.

Directions to be tested:

- *receiver target reference direction* (see ETSI TS 137 145-2 [3], table 4.10-1, D10.9),
- conformance test directions (see ETSI TS 137 145-2 [3], table 4.10-1, D10.10).

5.3.24.3 Procedure

- 1) Place the AAS BS with its coordinate system reference point in the same place as calibrated point in the test system.

NOTE: Example of measurement test setup is in ETSI TS 137 145-2 [3], clause D.1.1.

- 2) Align the coordinate system orientation of the AAS BS with the test system.
- 3) Align the BS with the test antenna in the direction to be tested.
- 4) Ensure the polarization is accounted for such that all the power from the test antenna is captured by the AAS BS.
- 5) Configure the *beam peak direction* of the AAS BS according to *reference beam direction pair* for the appropriate beam identifier.
- 6) Set the AAS BS to transmit the beam(s) of the same operational band and RAT as the OSDD being tested according to the appropriate test configuration in ETSI TS 137 145-2 [3], clause 5.
- 7) Set the signal generator for the wanted signal according to the applicable test configuration (see clause 5 in ETSI TS 137 145-2 [3]) using applicable reference measurement channel .
- 8) Set the test signal mean power so the calibrated radiated power at the AAS BS Antenna Array coordinate system reference point is as specified in clause 4.3.24.2.
- 9) Measure BER (UTRA) and *throughput* (E-UTRA and NR) for applicable reference measurement channels.
- 10) Repeat steps 3 to 9 for all OSDD(s) for the AAS BS (see ETSI TS 137 145-2 [3], table 4.10-1, D.10.1), and supported polarizations.

For multi-band capable AAS BS and single band tests, repeat the steps above per involved band where single band test configurations and test models shall apply with no carriers activated in the other band.

5.3.24.4 Test requirement

The results shall fulfil the conditions and limits of clause 4.3.24.2.

5.3.25 OTA reference sensitivity level

5.3.25.1 General

The test purpose is to verify that the BS can meet the *throughput* requirement for a specified measurement channel at the $EIS_{REFSENS}$ level and the range of angles of arrival within the *OTA REFSENS RoAoA*.

5.3.25.2 Initial conditions

Test environment:

- Normal: see ETSI TS 137 145-2 [3], clause G.2.

RF channels to be tested:

- B, M and T; see clause 5.3.1.

Directions to be tested:

- OTA REFSENS *receiver target reference direction* (see ETSI TS 137 145-2 [3], table 4.10-2, D11.30).
- OTA REFSENS conformance test directions (see table ETSI ETSI TS 137 145-2 [3], 4.10-2, D11.31).

5.3.25.3 Procedure

- 1) Place the AAS BS with its coordinate system reference point in the same place as calibrated point in the test system.

NOTE: Example of measurement test setup is in ETSI TS 137 145-2 [3], clause D.1.1.

- 2) Align the coordinate system orientation of the AAS BS with the test system.
- 3) Align the BS with the test antenna in the direction to be tested.
- 4) Ensure the polarization is accounted for such that all the power from the test antenna is captured by the AAS BS.
- 5) Configure the *beam peak direction* of the AAS BS according to *reference beam direction pair* for the appropriate beam identifier.
- 6) Set the AAS BS to transmit the beam(s) of the same operational band and RAT as the *OTA REFSENS RoAoA* being tested according to the appropriate test configuration in ETSI TS 137 145-2 [3], clause 5.
- 7) Set the signal generator for the wanted signal according to the applicable test configuration (see clause 5 in in ETSI TS 137 145-2 [3]) using applicable reference measurement channel.
- 8) Set the test signal mean power so the calibrated radiated power at the AAS BS Antenna Array coordinate system reference point is as specified in clause 4.3.25.
- 9) Measure BER (UTRA) and *throughput* (E-UTRA and NR) for applicable reference measurement channels.
- 10) Repeat steps 3 to 9 for all directions to be tested, and supported polarizations.

For multi-band capable AAS BS and single band tests, repeat the steps above per involved band where single band test configurations and test models shall apply with no carriers activated in the other band.

5.3.25.4 Test requirement

The results shall fulfil the conditions and limits of clause 4.3.25.2.

Annex A (informative): Relationship between the present document and the essential requirements of Directive 2014/53/EU

The present document has been prepared under the Commission's standardisation request C(2015) 5376 final [i.1] to provide one voluntary means of conforming to the essential requirements of Directive 2014/53/EU on the harmonisation of the laws of the Member States relating to the making available on the market of radio equipment and repealing Directive 1999/5/EC [i.2].

Once the present document is cited in the Official Journal of the European Union under that Directive, compliance with the normative clauses of the present document given in table A.1 confers, within the limits of the scope of the present document, a presumption of conformity with the corresponding essential requirements of that Directive and associated EFTA regulations.

**Table A.1: Relationship between the present document and
the essential requirements of Directive 2014/53/EU**

Harmonised Standard ETSI EN 301 908-23					
Requirement				Requirement Conditionality	
No	Description	Essential requirements of Directive	Clause(s) of the present document	U/C	Condition
1	Operating band unwanted emissions	3.2	4.3.2	C	Only applicable to <i>Hybrid AAS BS</i> (E-UTRA and NR only)
2	Spectrum Emission mask (SEM)	3.2	4.3.3	C	Only applicable to <i>Hybrid AAS BS</i> (UTRA only)
3	Adjacent Channel Leakage power Ratio (ACLR)	3.2	4.3.4	C	Only applicable to <i>Hybrid AAS BS</i>
4	Transmitter spurious emissions	3.2	4.3.5	C	Only applicable to <i>Hybrid AAS BS</i>
5	Base station maximum output power	3.2	4.3.6	C	Only applicable to <i>Hybrid AAS BS</i>
6	Transmit intermodulation	3.2	4.3.7	C	Only applicable to <i>Hybrid AAS BS</i>
7	Receiver spurious emissions	3.2	4.3.8	C	Only applicable to <i>Hybrid AAS BS</i>
8	Blocking	3.2	4.3.9	C	Only applicable to <i>Hybrid AAS BS</i>
9	Receiver intermodulation	3.2	4.3.10	C	Only applicable to <i>Hybrid AAS BS</i>
10	Adjacent Channel Selectivity (ACS)	3.2	4.3.11	C	Only applicable to <i>Hybrid AAS BS</i>
11	Reference sensitivity level	3.2	4.3.12	C	Only applicable to <i>Hybrid AAS BS</i>
12	OTA operating band unwanted emissions	3.2	4.3.13	C	Only applicable to <i>OTA AAS BS</i> (E-UTRA and NR only)
13	OTA SEM	3.2	4.3.14	C	Only applicable to <i>OTA AAS BS</i> (UTRA only)
14	OTA ACLR	3.2	4.3.15	C	Only applicable to <i>OTA AAS BS</i>
15	OTA transmitter spurious emissions	3.2	4.3.16	C	Only applicable to <i>OTA AAS BS</i>
16	Radiated transmit power	3.2	4.3.17	U	
17	OTA Maximum output power	3.2	4.3.18	C	Only applicable to <i>OTA AAS BS</i>
18	OTA transmitter intermodulation	3.2	4.3.19	C	Only applicable to <i>OTA AAS BS</i>
19	OTA receiver spurious emissions	3.2	4.3.20	C	Only applicable to <i>OTA AAS BS</i>
20	OTA blocking	3.2	4.3.21	C	Only applicable to <i>OTA AAS BS</i>

Harmonised Standard ETSI EN 301 908-23					
Requirement				Requirement Conditionality	
No	Description	Essential requirements of Directive	Clause(s) of the present document	U/C	Condition
21	OTA receiver intermodulation	3.2	4.3.22	C	Only applicable to OTA AAS BS
22	OTA ACS	3.2	4.3.23	C	Only applicable to OTA AAS BS
23	OTA sensitivity	3.2	4.3.24	U	
24	OTA reference sensitivity level	3.2	4.3.25	C	Only applicable to OTA AAS BS

Key to columns:**Requirement:**

No A unique identifier for one row of the table which may be used to identify a requirement.

Description A textual reference to the requirement.

Essential requirements of Directive

Identification of article(s) defining the requirement in the Directive.

Clause(s) of the present document

Identification of clause(s) defining the requirement in the present document unless another document is referenced explicitly.

Requirement Conditionality:

U/C Indicates whether the requirement is unconditionally applicable (U) or is conditional upon the manufacturer's claimed functionality of the equipment (C).

Condition Explains the conditions when the requirement is or is not applicable for a requirement which is classified "conditional".

Presumption of conformity stays valid only as long as a reference to the present document is maintained in the list published in the Official Journal of the European Union. Users of the present document should consult frequently the latest list published in the Official Journal of the European Union.

Other Union legislation may be applicable to the product(s) falling within the scope of the present document.

Annex B (informative): Maximum Measurement Uncertainty

The measurements described in the present document are based on the following assumptions:

- the measured value related to the corresponding limit is used to decide whether an equipment meets the requirements of the present document;
- the value of the measurement uncertainty for the measurement of each parameter is included in the test report.

For the test methods, the recommended values of the maximum measurement uncertainty are calculated and correspond to an expansion factor (coverage factor) $k = 1,96$ (which provide confidence level of 95 % in the case where the distributions characterizing the actual measurement uncertainties are normal (Gaussian)). Principles for the calculation of measurement uncertainty are contained in ETSI TR 100 028 [i.5], in particular in annex D of the ETSI TR 100 028-2 [i.5].

Tables B.1 to B.6 show the recommended values for the maximum measurement uncertainty figures.

Table B.1: Maximum measurement uncertainty for conducted transmitter tests

Parameter	Condition	Uncertainty
Operating band unwanted emissions (for E-UTRA)	General limits $f \leq 3,0$ GHz $3,0$ GHz $< f \leq 4,2$ GHz	$\pm 1,5$ dB $\pm 1,8$ dB
Spectrum emission mask (for UTRA)	General limits $f \leq 3,0$ GHz $3,0$ GHz $< f \leq 4,2$ GHz	$\pm 1,5$ dB $\pm 1,8$ dB
Adjacent Channel Leakage power Ratio (ACLR)	ACLR BW ≤ 20 MHz BW > 20 MHz ACLR absolute power $f \leq 3,0$ GHz $3,0$ GHz $< f \leq 4,2$ GHz CACLR BW ≤ 20 MHz BW > 20 MHz CACLR absolute power $f \leq 3,0$ GHz $3,0$ GHz $< f \leq 4,2$ GHz	$\pm 0,8$ dB $\pm 1,2$ dB $\pm 2,0$ dB $\pm 2,5$ dB $\pm 0,8$ dB $\pm 1,2$ dB $\pm 2,0$ dB $\pm 2,5$ dB
Transmitter spurious emissions	General requirements 9 kHz $< f \leq 4$ GHz 4 GHz $< f \leq 19$ GHz For co-existence requirements (> -60 dBm) $f \leq 3,0$ GHz $3,0$ GHz $< f \leq 4,2$ GHz For co-existence requirements (≤ -60 dBm) $f \leq 3,0$ GHz $3,0$ GHz $< f \leq 4,2$ GHz For protection of the <i>BS receiver</i>	$\pm 2,0$ dB $\pm 4,0$ dB $\pm 2,0$ dB $\pm 2,5$ dB $\pm 3,0$ dB $\pm 3,5$ dB $\pm 3,0$ dB
Base station maximum output power	For UTRA and E-UTRA and NR $f \leq 3,0$ GHz $3,0$ GHz $< f \leq 4,2$ GHz	$\pm 0,7$ dB $\pm 1,0$ dB

Parameter	Condition	Uncertainty
Transmit intermodulation	For <i>Operating band unwanted emissions</i>	±2,5 dB
	For ACLR	±2,2 dB
	For spurious emissions	
	$f \leq 2,2$ GHz	±2,5 dB
	$2,2$ GHz < $f \leq 4$ GHz	±2,8 dB
	$f > 4$ GHz	±4,5 dB
	For co-existence requirements	±2,8 dB
	Interfering signal	±1,0 dB
NOTE 1: For conducted RF tests, it should be noted that the uncertainties in this table are valid for a test system operating into a nominal 50 Ω load and do not include system effects due to mismatch between the EUT and the Test System.		
NOTE 2: Annex G of ETSI TR 100 028-2 [i.5] provides guidance for the calculation of the uncertainty components relating to mismatch.		

Table B.2: Maximum measurement uncertainty for conducted receiver tests

Parameter	Condition	Uncertainty
Receiver spurious emissions	30 MHz $\leq f \leq 4$ GHz	±2,0 dB
	4 GHz < $f \leq 19$ GHz	±4,0 dB
ACS, general blocking and narrowband blocking	$f \leq 3,0$ GHz	±1,4 dB
	$3,0$ GHz < $f \leq 4,2$ GHz	±1,8 dB
Out-of-band blocking	1 MHz < $f_{\text{interferer}} \leq 3$ GHz	±1,3 dB
	3 GHz < $f_{\text{interferer}} \leq 12,75$ GHz	±3,2 dB
Receiver intermodulation characteristics	For general and narrowband intermodulation	
	$f \leq 3,0$ GHz	±1,8 dB
	$3,0$ GHz < $f \leq 4,2$ GHz	±2,4 dB
Reference sensitivity level	$f \leq 3,0$ GHz	±0,7 dB
	$3,0$ GHz < $f \leq 4,2$ GHz	±1,0 dB
NOTE 1: For conducted RF tests, it should be noted that the uncertainties in this table are valid for a test system operating into a nominal 50 Ω load and do not include system effects due to mismatch between the EUT and the Test System.		
NOTE 2: Annex G of ETSI TR 100 028-2 [i.5] provides guidance for the calculation of the uncertainty components relating to mismatch.		

Table B.3: Maximum measurement uncertainty for radiated transmitter tests

Parameter	Condition	Uncertainty
OTA OBUE	$f \leq 3,0$ GHz	±1,8 dB
	$3,0$ GHz < $f \leq 4,2$ GHz	±2,0 dB
OTA SEM	$f \leq 3,0$ GHz	±1,8 dB
	$3,0$ GHz < $f \leq 4,2$ GHz	±2,0 dB
OTA ACLR / CACLR	$f \leq 3,0$ GHz	±1,0 dB
	$3,0$ GHz < $f \leq 4,2$ GHz	±1,2 dB
	Absolute limit:	
	$f \leq 3,0$ GHz	±2,2 dB
	$3,0$ GHz < $f \leq 4,2$ GHz	±2,7 dB
OTA Transmitter spurious	General requirements	
	9 kHz < $f \leq 4$ GHz	±2,3 dB
	4 GHz < $f \leq 19$ GHz	±4,2 dB
	For protection of <i>BS receiver</i> :	
	$f \leq 3,0$ GHz	±3,1 dB
	$3,0$ GHz < $f \leq 4,2$ GHz	±3,3 dB
	Additional requirements:	
	$f \leq 3,0$ GHz	±2,6 dB
	$3,0$ GHz < $f \leq 4,2$ GHz	±3,0 dB
Radiated transmit power (normal test environment)	$f \leq 3,0$ GHz	±1,1 dB
	$3,0$ GHz < $f \leq 4,2$ GHz	±1,3 dB
Radiated transmit power (extreme test environment)	$f \leq 3,0$ GHz	±2,5 dB
	$3,0$ GHz < $f \leq 4,2$ GHz	±2,6 dB

Parameter	Condition	Uncertainty
OTA maximum output power	$f \leq 3,0$ GHz	$\pm 1,4$ dB
	$3,0$ GHz $< f \leq 4,2$ GHz	$\pm 1,5$ dB
OTA Transmitter intermodulation	For interfering signal: $f \leq 3,0$ GHz	$\pm 3,2$ dB
	$3,0$ GHz $< f \leq 4,2$ GHz	$\pm 3,4$ dB

Table B.4: Maximum measurement uncertainty for radiated receiver tests

Parameter	Condition	Uncertainty
OTA receiver spurious	30 MHz $\leq f \leq 4$ GHz	$\pm 2,5$ dB
	4 GHz $< f \leq 19$ GHz	$\pm 4,2$ dB
OTA Adjacent channel selectivity, general blocking, and narrowband blocking	$f \leq 3,0$ GHz $3,0$ GHz $< f \leq 4,2$ GHz	$\pm 1,7$ dB $\pm 2,1$ dB
OTA blocking	$f \leq 3,0$ GHz	
	1 MHz $< f_{\text{interferer}} \leq 3$ GHz	$\pm 2,0$ dB
	3 GHz $< f_{\text{interferer}} \leq 6$ GHz	$\pm 2,1$ dB
	6 GHz $< f_{\text{interferer}} \leq 12,75$ GHz	$\pm 3,5$ dB
	$3,0$ GHz $< f \leq 4,2$ GHz	
	1 MHz $< f_{\text{interferer}} \leq 3$ GHz	$\pm 2,0$ dB
OTA receiver intermodulation	General and narrowband requirements: $f \leq 3,0$ GHz	$\pm 2,0$ dB
	$3,0$ GHz $< f \leq 4,2$ GHz	$\pm 2,6$ dB
	3 GHz $< f_{\text{interferer}} \leq 6$ GHz	$\pm 2,1$ dB
	6 GHz $< f_{\text{interferer}} \leq 12,75$ GHz	$\pm 3,6$ dB
OTA sensitivity	$f \leq 3,0$ GHz	$\pm 1,3$ dB
	$3,0$ GHz $< f \leq 4,2$ GHz	$\pm 1,4$ dB
OTA reference sensitivity	$f \leq 3,0$ GHz	$\pm 1,3$ dB
	$3,0$ GHz $< f \leq 4,2$ GHz	$\pm 1,4$ dB

Annex C (normative): Base Station configurations for conducted testing

C.1 Transmit configurations

Conducted transmitter characteristics in clause 4 are specified at the AAS BS *transceiver array boundary* at the *TAB connector(s)* connector with a full complement of transceiver units for the configuration in normal operation.

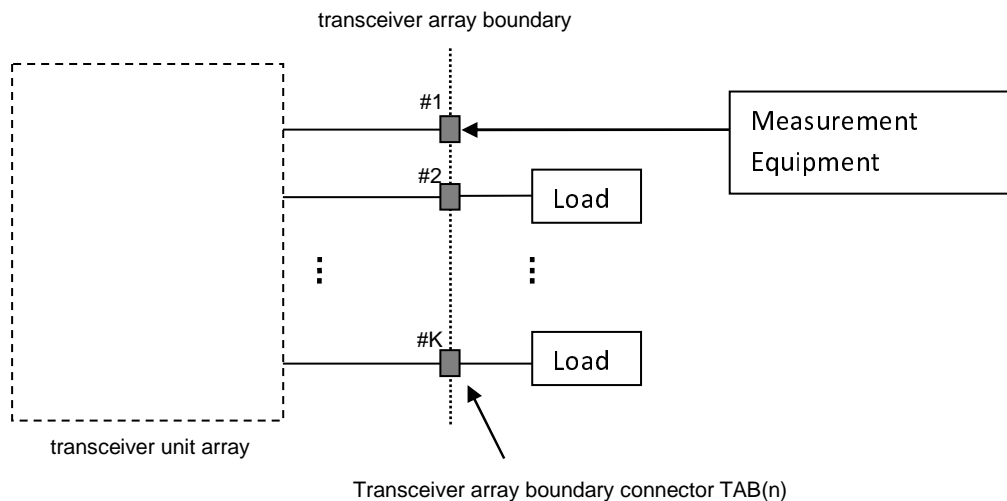

Figure C.1: Transmitter test ports

C.2 Receive configurations

Conducted receiver characteristics in clause 4 are specified at the *TAB connector* with a full complement of transceiver units for the configuration in normal operation.

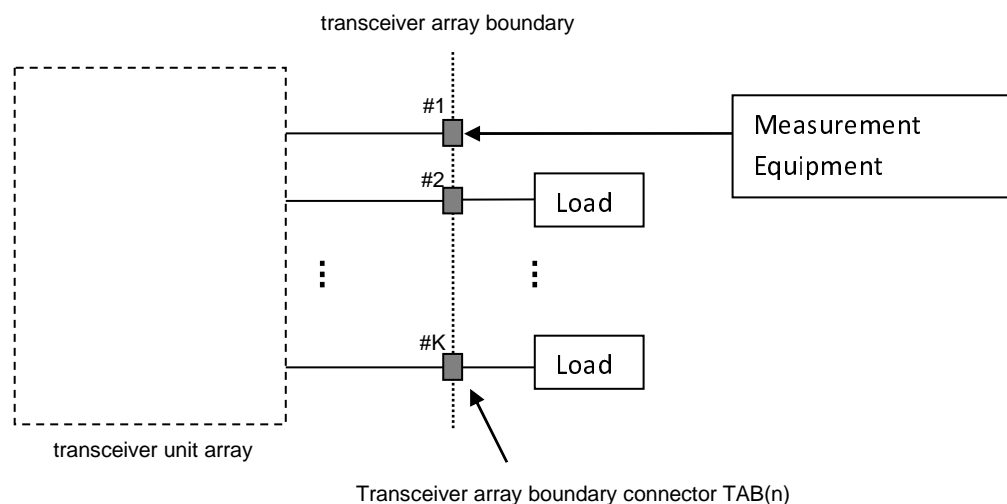

Figure C.2: Receiver test ports

Conducted receive requirements are tested at the *TAB connector*, with the remaining receiver units(s) disabled or their *TAB connector(s)* being terminated.

C.3 Power supply options

If the BS is supplied with a number of different power supply configurations, it may not be necessary to test RF parameters for each of the power supply options, provided that it can be demonstrated that the range of conditions over which the equipment is tested is at least as great as the range of conditions due to any of the power supply configurations.

C.4 BS with integrated Iuant BS modem

For the conducted tests in the present document, the integrated Iuant BS modem shall be switched off. Spurious emissions shall be measured only for frequencies above 20 MHz with the integrated Iuant BS modem switched on.

For the radiated tests in the present document, the integrated Iuant BS modem shall be switched off.

Annex D (normative): Base Station configurations for radiated testing

D.1 Transmit configurations

The radiated transmitter characteristics in clause 4 are specified at the *Radiated Interface Boundary (RIB)*, or at CLTA output. The AAS BS shall have a full complement of transceiver units for the configuration in normal operation.

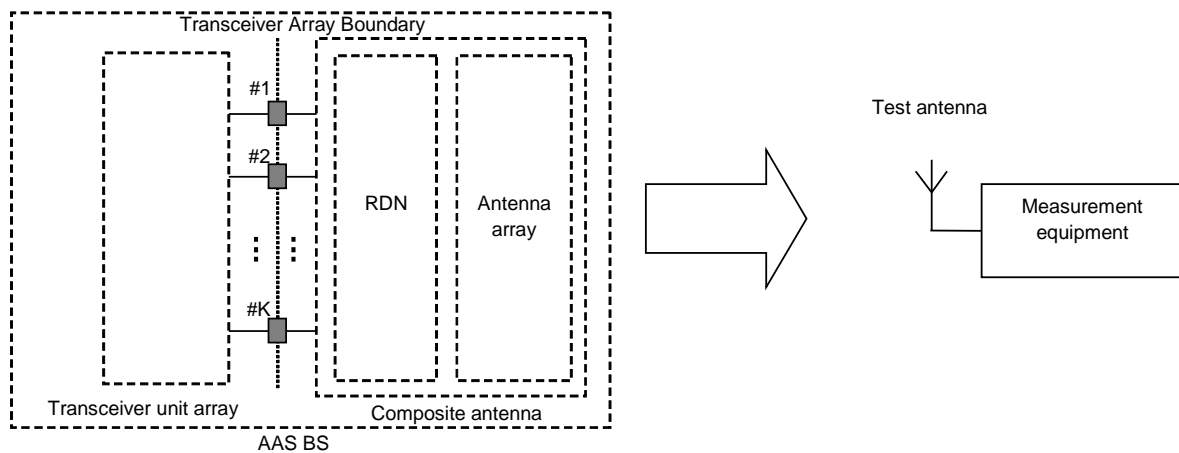

Figure D.1: Transmitter test interfaces

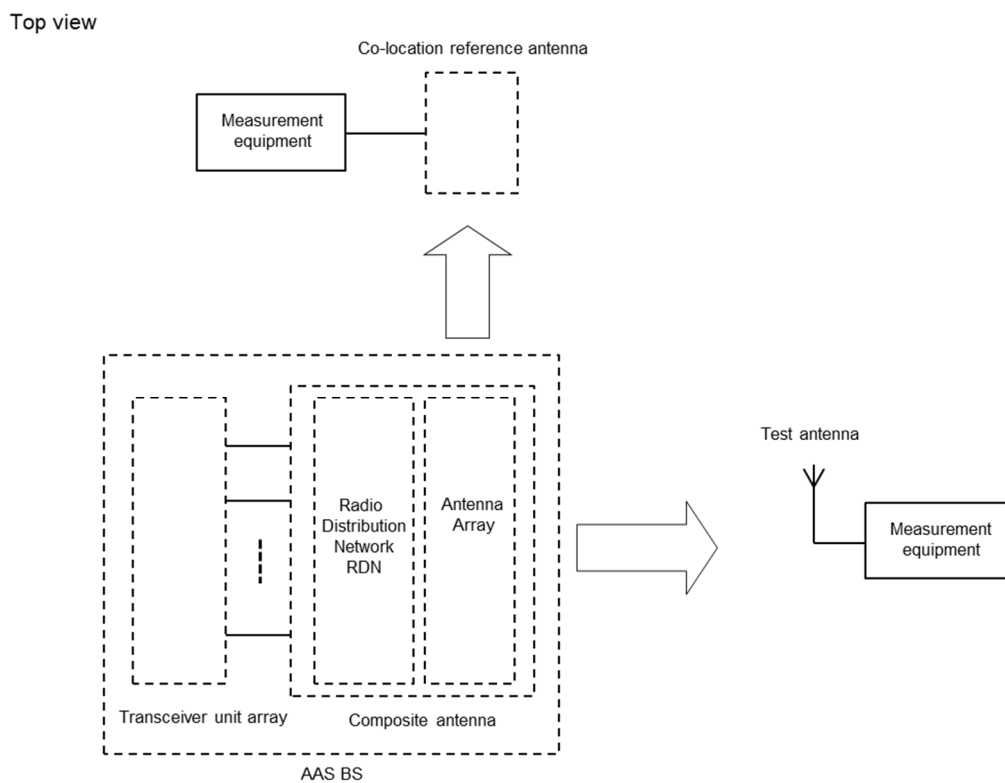

Figure D.2: Transmitter test interfaces for co-location concept

D.2 Receive configurations

The radiated receiver characteristics in clause 4 are specified at the *Radiated Interface Boundary* (RIB), or at CLTA output. The AAS BS shall have a full complement of transceiver units for the configuration in normal operation.

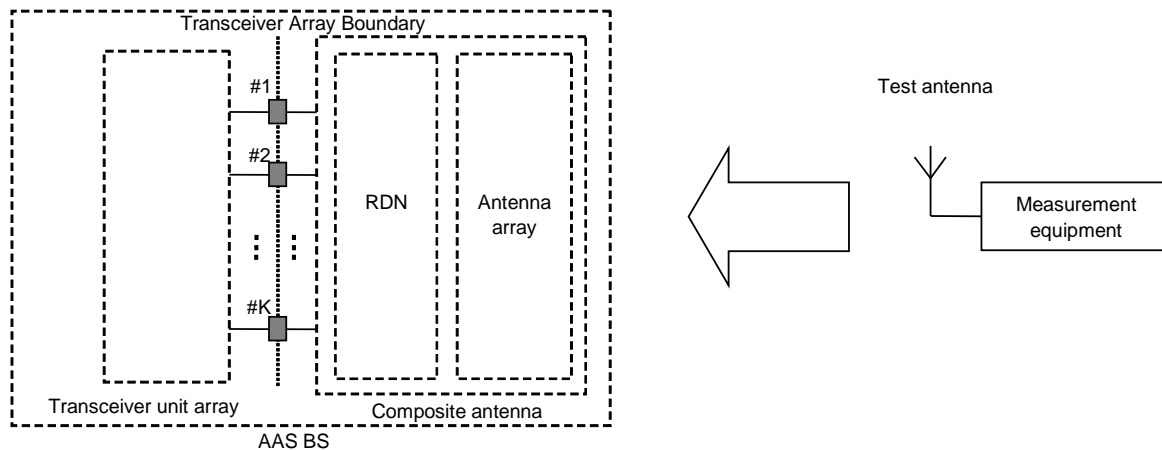

Figure D.3: Receiver test interfaces

Top view

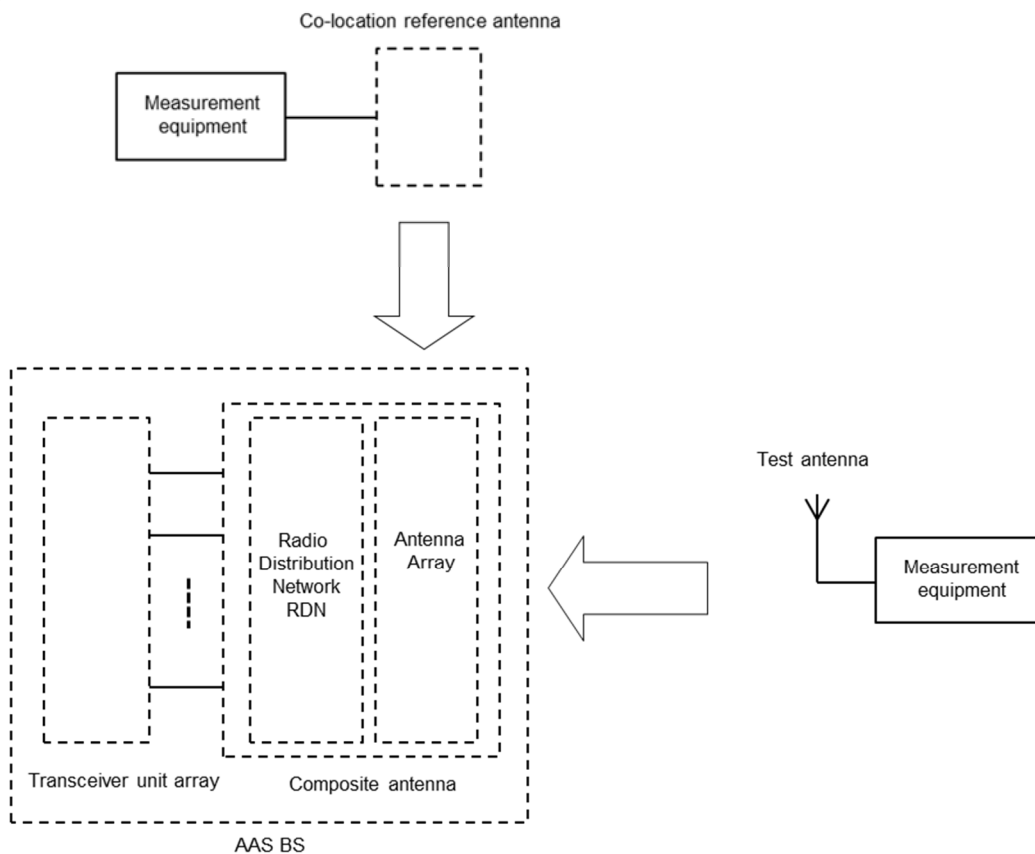

Figure D.4: Receiver test interfaces for co-location concept

D.3 Power supply options

If the AAS BS is supplied with a number of different power supply configurations, it may not be necessary to test RF parameters for each of the power supply options, provided that it can be demonstrated that the range of conditions over which the equipment is tested is at least as great as the range of conditions due to any of the power supply configurations.

D.4 BS with integrated Iuant BS modem

For the tests in the present document, the integrated Iuant BS modem shall be switched off.

Annex E (informative): Checklist

This annex provides a traceability of the technical parameters for article 3.2 of Directive 2014/53/EU [i.2] defined in ETSI EG 203 336 [i.3] with the technical requirements for conformance defined in clause 4 of the present document.

If a technical parameter for article 3.2 of Directive 2014/53/EU [i.2] defined in ETSI EG 203 336 [i.3] has not been included in the present document, an explanation is provided. More details are included in ETSI TR 103 877 [i.7].

An explanation is also provided whenever a technical parameter defined in ETSI EG 203 336 [i.3] is covered by an alternative technical requirement.

Table E.1: Checklist

Technical Parameters defined in ETSI EG 203 336 [i.3]	Clauses of the present document	Comments
Transmitter Parameters		
Transmitter Spectrum mask	4.3.2	
Transmitter unwanted emissions in the out-of-band domain	4.3.3 4.3.4 4.3.13 4.3.14 4.3.15	
Transmitter unwanted emissions in the spurious domain	4.3.5 4.3.16	
Transmit power limits	N/A	See clause 4.2.2 in ETSI TR 103 877 [i.7].
Transmit power accuracy	4.3.6 4.3.17 4.3.18	
Transmitter Frequency stability	N/A	See clause 4.2.3 in ETSI TR 103 877 [i.7].
Transmitter Intermodulation attenuation	4.3.7 4.3.19	
Transmitter Time domain characteristics (e.g. the duty cycle, turn-on and turn-off, frequency hopping cycle, dynamic changes of modulation scheme and others)	N/A	See clause 4.2.5 in ETSI TR 103 877 [i.7].
Transmitter Transients	N/A	See clause 4.2.6 in ETSI TR 103 877 [i.7].
Receiver Parameters		
Receiver sensitivity	4.3.12 4.3.24 4.3.25	
Receiver co-channel rejection	N/A	See clause 4.2.7 in ETSI TR 103 877 [i.7].
Adjacent band/channel selectivity	4.3.11 4.3.23	
Spurious response rejection	N/A	See clause 4.2.8 in ETSI TR 103 877 [i.7].
Receiver blocking	4.3.9 4.3.21	
Receiver radio-frequency intermodulation	4.3.10 4.3.22	
Receiver unwanted emissions in the spurious domain	4.3.8 4.3.20	
Receiver dynamic range	N/A	See clause 4.2.9 in ETSI TR 103 877 [i.7].
Reciprocal mixing	N/A	See clause 4.2.9 in ETSI TR 103 877 [i.7].

Annex F (informative): Bibliography

- Directive 2014/30/EU of the European Parliament and of the Council of 26 February 2014 on the harmonisation of the laws of the Member States relating to electromagnetic compatibility (recast). This one is applicable from 20 April 2016 and repeals the Directive 2004/108/EC.
- Directive 2014/35/EU of the European Parliament and of the Council of 26 February 2014 on the harmonisation of the laws of the Member States relating to the making available on the market of electrical equipment designed for use within certain voltage limits (recast) (LV Directive).
- Commission Implementing Decision 2012/688/EU of 5 November 2012 on the harmonisation of the frequency bands 1 920-1 980 MHz and 2 110-2 170 MHz for terrestrial systems capable of providing electronic communications services in the Union.
- Commission Decision (EU) 2018/661 of 28 April 2018 on the harmonisation of the 1 452-1 492 MHz frequency band for terrestrial systems capable of providing electronic communications services in the Union.
- Regulation (EU) No 1025/2012 of the European Parliament and of the Council of 25 October 2012 on European standardisation amending Council Directives 89/686/EEC and 93/15/EEC and Directives 94/9/EC, 94/25/EC, 95/16/EC, 97/23/EC, 98/34/EC, 2004/22/EC, 2007/23/EC, 2009/23/EC and 2009/105/EC of the European Parliament and of the Council and repealing Council Decision 87/95/EEC and Decision No 1673/2006/EC of the European Parliament and of the Council.

Annex G (informative): Change history

Version	Information about changes
13.1.1_0.0.1	First draft - skeleton
13.1.1_0.0.2	Second draft - based on a common part which have references to two TSs created from the original 3GPP specs for conducted and radiated conformance testing
13.1.1_0.0.3	New draft without requirements and test suites
15.1.1_0.0.6	First stable draft after conversion to Rel 15
V15.1.1_0.0.7	New complete draft after in TFES#68
V15.1.1_0.0.9	New complete draft after in TFES#68
V15.1.1_0.0.10	New revision, table 1-1 in special, new references, bibliography
V15.1.1_0.0.10 to 12	Minor corrections and update the references to latest version
V15.1.1_0.0.13 and 14	Corrections taking into account HAS feedback
V15.1.1_0.0.15	Added annex with checklist on parameter selection, approved at TFES #73
V15.1.1_0.0.16-18	Revisions during and after TFES #75 - Added ECC Dec 14(02) updated
V15.1.1_0.0.19	Revision during TFES #76

History

Document history				
V15.0.0	December 2022	EN Approval Procedure	AP 20230307:	2022-12-07 to 2023-03-07
V15.0.1	July 2023	Vote	V 20230904:	2023-07-06 to 2023-09-04