

**IMT cellular networks;
Harmonised EN covering the essential requirements
of article 3.2 of the R&TTE Directive;
Part 21: OFDMA TDD WMAN (Mobile WiMAX)
FDD User Equipment (UE)**



Reference

DEN/MSG-TFES-009-21

Keywords

WiMAX, IMT, IMT-2000, mobile, radio, regulation,
OFDMA, FDD, WMAN

ETSI

650 Route des Lucioles
F-06921 Sophia Antipolis Cedex - FRANCE

Tel.: +33 4 92 94 42 00 Fax: +33 4 93 65 47 16

Siret N° 348 623 562 00017 - NAF 742 C
Association à but non lucratif enregistrée à la
Sous-Préfecture de Grasse (06) N° 7803/88

Important notice

Individual copies of the present document can be downloaded from:

<http://www.etsi.org>

The present document may be made available in more than one electronic version or in print. In any case of existing or perceived difference in contents between such versions, the reference version is the Portable Document Format (PDF). In case of dispute, the reference shall be the printing on ETSI printers of the PDF version kept on a specific network drive within ETSI Secretariat.

Users of the present document should be aware that the document may be subject to revision or change of status. Information on the current status of this and other ETSI documents is available at

<http://portal.etsi.org/tb/status/status.asp>

If you find errors in the present document, please send your comment to one of the following services:

http://portal.etsi.org/chaicor/ETSI_support.asp

Copyright Notification

No part may be reproduced except as authorized by written permission.
The copyright and the foregoing restriction extend to reproduction in all media.

© European Telecommunications Standards Institute 2011.
All rights reserved.

DECT™, PLUGTESTS™, UMTS™ and the ETSI logo are Trade Marks of ETSI registered for the benefit of its Members.
3GPP™ and LTE™ are Trade Marks of ETSI registered for the benefit of its Members and
of the 3GPP Organizational Partners.
GSM® and the GSM logo are Trade Marks registered and owned by the GSM Association.

Contents

Intellectual Property Rights	6
Foreword.....	6
Introduction	7
1 Scope	8
2 References	8
2.1 Normative references	8
2.2 Informative references.....	8
3 Definitions, symbols and abbreviations	9
3.1 Definitions	9
3.2 Symbols.....	10
3.3 Abbreviations	10
4 Essential requirements specification	11
4.1 Environmental profile.....	11
4.2 Conformance requirements	11
4.2.1 Introduction.....	11
4.2.2 Transmitter spectrum emission mask.....	11
4.2.2.1 Definition	11
4.2.2.2 Limits	12
4.2.2.2.1 Requirements for 5 MHz channel bandwidth	12
4.2.2.2.2 Requirements for 10 MHz channel bandwidth	12
4.2.2.3 Conformance.....	12
4.2.3 Transmitter Adjacent Channel Leakage power Ratio (ACLR)	12
4.2.3.1 Definition	12
4.2.3.2 Limits	12
4.2.3.2.1 ACLR requirements for 5 MHz bandwidth	12
4.2.3.2.2 ACLR requirements for 10 MHz bandwidth	13
4.2.3.3 Conformance.....	13
4.2.4 Transmitter spurious emissions.....	13
4.2.4.1 Definition	13
4.2.4.2 Limits	13
4.2.4.2.1 Requirements for 5 MHz channel bandwidth	14
4.2.4.2.2 Requirements for 10 MHz channel bandwidth	14
4.2.4.2.3 Requirements for UE coexistence	14
4.2.4.3 Conformance.....	14
4.2.5 Transmitter Maximum Output Power	14
4.2.5.1 Definition	14
4.2.5.2 Limits	15
4.2.5.3 Conformance.....	15
4.2.6 Transmitter Minimum Output Power.....	15
4.2.6.1 Definition	15
4.2.6.2 Limits	15
4.2.6.3 Conformance.....	15
4.2.7 Receiver spurious emissions	15
4.2.7.1 Definition	15
4.2.7.2 Limits	15
4.2.7.3 Conformance.....	15
4.2.8 Receiver Adjacent Channel Selectivity (ACS)	15
4.2.8.1 Definition	15
4.2.8.2 Limits	16
4.2.8.3 Conformance.....	16
4.2.9 Receiver blocking characteristics	16
4.2.9.1 Definition	16
4.2.9.2 Limits	17

4.2.9.3	Conformance	17
4.2.10	Receiver intermodulation characteristics	17
4.2.10.1	Definition and applicability	17
4.2.10.2	Limits	18
4.2.10.3	Conformance	18
4.2.11	Receiver spurious response	18
4.2.11.1	Definition	18
4.2.11.2	Limits	18
4.2.11.3	Conformance	19
5	Testing for compliance with technical requirements	19
5.1	Environmental conditions for testing	19
5.2	Product information	19
5.3	Interpretation of the measurement results	20
5.4	Essential radio test suites	20
5.4.1	Transmitter Spectrum Emission Mask	21
5.4.1.1	Method of measurement	21
5.4.1.1.1	Initial conditions	21
5.4.1.1.2	Procedure	21
5.4.1.2	Test requirements	22
5.4.2	Transmitter Adjacent Channel Leakage Power Ratio	22
5.4.2.1	Method of measurement	22
5.4.2.1.1	Initial conditions	22
5.4.2.1.2	Procedure	23
5.4.2.2	Test requirements	23
5.4.3	Transmitter spurious emissions	23
5.4.3.1	Method of measurement	23
5.4.3.1.1	Initial conditions	24
5.4.3.1.2	Procedure	24
5.4.3.2	Test requirements	24
5.4.4	Transmitter Maximum and Minimum Output Power	25
5.4.4.1	Method of measurement	25
5.4.4.1.1	Initial conditions	25
5.4.4.1.2	Procedure	25
5.4.4.2	Test requirements	26
5.4.5	Receiver spurious emissions	26
5.4.5.1	Method of measurement	26
5.4.5.1.1	Initial conditions	26
5.4.5.1.2	Procedure	27
5.4.5.2	Test requirements	27
5.4.6	Receiver Adjacent Channel Selectivity (ACS)	27
5.4.6.1	Method of measurement	27
5.4.6.1.1	Initial conditions	28
5.4.6.1.2	Procedure	28
5.4.6.2	Test requirements	28
5.4.7	Receiver blocking characteristics	29
5.4.7.1	Method of measurement	29
5.4.7.1.1	Initial conditions	29
5.4.7.1.2	Procedure	29
5.4.7.2	Test requirements	30
5.4.8	Receiver intermodulation characteristics	30
5.4.8.1	Method of measurement	30
5.4.8.1.1	Initial conditions	30
5.4.8.1.2	Procedure	31
5.4.8.2	Test requirements	31
5.4.9	Receiver spurious response	31
5.4.9.1	Method of measurement	31
5.4.9.1.1	Initial conditions	32
5.4.9.1.2	Procedure	32
5.4.9.2	Test requirements	32

Annex A (normative):	HS Requirements and conformance Test specifications Table (HS-RTT).....	33
Annex B (normative):	Environmental profile specification	35
Annex C (informative):	The EN title in the official languages	36
Annex D (informative):	Bibliography.....	37
History		38

Intellectual Property Rights

IPRs essential or potentially essential to the present document may have been declared to ETSI. The information pertaining to these essential IPRs, if any, is publicly available for **ETSI members and non-members**, and can be found in ETSI SR 000 314: "*Intellectual Property Rights (IPRs); Essential, or potentially Essential, IPRs notified to ETSI in respect of ETSI standards*", which is available from the ETSI Secretariat. Latest updates are available on the ETSI Web server (<http://ipr.etsi.org>).

Pursuant to the ETSI IPR Policy, no investigation, including IPR searches, has been carried out by ETSI. No guarantee can be given as to the existence of other IPRs not referenced in ETSI SR 000 314 (or the updates on the ETSI Web server) which are, or may be, or may become, essential to the present document.

Foreword

This final draft Harmonized European Standard (EN) has been produced by ETSI Technical Committee Mobile Standards Group (MSG), and is now submitted for the Vote phase of the ETSI standards Two-step Approval Procedure.

The present document has been produced by ETSI in response to mandate M/284 from the European Commission issued under Council Directive 98/34/EC [i.1] (as amended) laying down a procedure for the provision of information in the field of technical standards and regulations.

The title and reference to the present document are intended to be included in the publication in the Official Journal of the European Union of titles and references of Harmonized Standard under the Directive 1999/5/EC [i.2].

See article 5.1 of Directive 1999/5/EC [i.2] for information on presumption of conformity and Harmonised Standards or parts thereof the references of which have been published in the Official Journal of the European Union.

The requirements relevant to Directive 1999/5/EC [i.2] are summarised in annex A.

The present document is part 21 of a multi-part deliverable covering the essential requirements under article 3.2 of Directive 1999/5/EC [i.2] (R&TTE Directive) for Base Stations (BS), Repeaters and User Equipment (UE) for IMT- cellular networks, as identified below:

- Part 1: "Introduction and common requirements";
- Part 2: "CDMA Direct Spread (UTRA FDD) User Equipment (UE)";
- Part 3: "CDMA Direct Spread (UTRA FDD) Base Stations (BS)";
- Part 4: "CDMA Multi-Carrier (cdma2000) User Equipment (UE)";
- Part 5: "CDMA Multi-Carrier (cdma2000) Base Stations (BS)";
- Part 6: "CDMA TDD (UTRA TDD) User Equipment (UE)";
- Part 7: "CDMA TDD (UTRA TDD) Base Stations (BS)";
- Part 8: "Harmonized EN for IMT-2000, TDMA Single-Carrier (UWC 136) (UE) covering essential requirements of article 3.2 of the R&TTE Directive";
- Part 9: "Harmonized EN for IMT-2000, TDMA Single-Carrier (UWC 136) (BS) covering essential requirements of article 3.2 of the R&TTE Directive";
- Part 10: "Harmonized EN for IMT-2000, FDMA/TDMA (DECT) covering essential requirements of article 3.2 of the R&TTE Directive";
- Part 11: "CDMA Direct Spread (UTRA FDD) (Repeaters)";
- Part 12: "Harmonized EN for IMT-2000, CDMA Multi-Carrier (cdma2000) (Repeaters) covering the essential requirements of article 3.2 of the R&TTE Directive";
- Part 13: "Evolved Universal Terrestrial Radio Access (E-UTRA) User Equipment (UE)";

- Part 14: "Evolved Universal Terrestrial Radio Access (E-UTRA) Base Stations (BS)";
- Part 15: "Evolved Universal Terrestrial Radio Access (E-UTRA) (FDD Repeaters)";
- Part 16: "Harmonized EN for IMT-2000, Evolved CDMA Multi-Carrier Ultra Mobile Broadband (UMB) (UE) covering the essential requirements of article 3.2 of the R&TTE Directive";
- Part 17: "Harmonized EN for IMT-2000, Evolved CDMA Multi-Carrier Ultra Mobile Broadband (UMB) (BS) covering the essential requirements of article 3.2 of the R&TTE Directive";
- Part 18: "E-UTRA, UTRA and GSM/EDGE Multi-Standard Radio (MSR) Base Stations (BS)";
- Part 19: "OFDMA TDD WMAN (Mobile WiMAX) TDD User Equipment (UE)";
- Part 20: "OFDMA TDD WMAN (Mobile WiMAX) TDD Base Station (BS)";
- Part 21: "OFDMA TDD WMAN (Mobile WiMAX) FDD User Equipment (UE)";**
- Part 22: "OFDMA TDD WMAN (Mobile WiMAX) FDD Base Stations (BS)".

Proposed national transposition dates	
Date of latest announcement of this EN (doa):	3 months after ETSI publication
Date of latest publication of new National Standard or endorsement of this EN (dop/e):	6 months after doa
Date of withdrawal of any conflicting National Standard (dow):	18 months after doa

Introduction

The present document is part of a set of standards developed by ETSI and is designed to fit in a modular structure to cover all radio and telecommunications terminal equipment within the scope of the R&TTE Directive [i.2]. The modular structure is shown in EG 201 399 [i.3].

1 Scope

The present document applies to the following radio equipment type:

- Mobile WiMAX FDD User Equipment for IMT-OFDMA TDD WMAN.

This radio equipment type is capable of operating in all or any part of the frequency bands given in table 1-1.

Table 1-1: Mobile WiMAX FDD Operating frequency bands

Mobile WiMAX Band Class Index	Direction of transmission	Mobile WiMAX FDD frequency bands
7G	Transmit	880 MHz to 915 MHz
	Receive	925 MHz to 960 MHz
6C	Transmit	1 710 MHz to 1 785 MHz
	Receive	1 805 MHz to 1 880 MHz

The present document is intended to cover the provisions of Directive 1999/5/EC [i.2] (R&TTE Directive), article 3.2, which states that "..... radio equipment shall be so constructed that it effectively uses the spectrum allocated to terrestrial/space radio communications and orbital resources so as to avoid harmful interference".

In addition to the present document, other ENs that specify technical requirements in respect of essential requirements under other parts of article 3 of the R&TTE Directive [i.2] may apply to equipment within the scope of the present document.

NOTE: A list of such ENs is included on the web site <http://www.newapproach.org>.

2 References

References are either specific (identified by date of publication and/or edition number or version number) or non-specific. For specific references, only the cited version applies. For non-specific references, the latest version of the reference document (including any amendments) applies.

Referenced documents which are not found to be publicly available in the expected location might be found at <http://docbox.etsi.org/Reference>.

NOTE: While any hyperlinks included in this clause were valid at the time of publication ETSI cannot guarantee their long term validity.

2.1 Normative references

The following referenced documents are necessary for the application of the present document.

- [1] ETSI EN 301 908-1 (V5.2.1): "IMT cellular networks; Harmonized EN covering the essential requirements of article 3.2 of the R&TTE Directive; Part 1: Introduction and common requirements".
- [2] CEPT/ERC/Recommendation 74-01E (Siófok 98, Nice 99, Sesimbra 02, Hradec Kralove 05): "Unwanted emissions in the spurious domain".

2.2 Informative references

The following referenced documents are not necessary for the application of the present document but they assist the user with regard to a particular subject area.

- [i.1] Directive 98/34/EC of the European Parliament and of the Council of 22 June 1998 laying down a procedure for the provision of information in the field of technical standards and regulations.

- [i.2] Directive 1999/5/EC of the European Parliament and of the Council of 9 March 1999 on radio equipment and telecommunications terminal equipment and the mutual recognition of their conformity (R&TTE Directive).
- [i.3] ETSI EG 201 399: "Electromagnetic compatibility and Radio spectrum Matters (ERM); A guide to the production of Harmonized Standards for application under the R&TTE Directive".
- [i.4] ETSI EN 300 019-1-0: "Environmental Engineering (EE); Environmental conditions and environmental tests for telecommunications equipment; Part 1-0: Classification of environmental conditions; Introduction".
- [i.5] ETSI TR 102 215 (V1.3.1): "Electromagnetic compatibility and Radio spectrum Matters (ERM); Recommended approach, and possible limits for measurement uncertainty for the measurement of radiated electromagnetic fields above 1 GHz".
- [i.6] ETSI TR 100 028 (V1.4.1) (all parts): "Electromagnetic compatibility and Radio spectrum Matters (ERM); Uncertainties in the measurement of mobile radio equipment characteristics".
- [i.7] ITU-R Recommendation SM.329-10 (2003): "Unwanted emissions in the spurious domain".

3 Definitions, symbols and abbreviations

3.1 Definitions

For the purposes of the present document, the terms and definitions given in the R&TTE Directive [i.2] and the following apply:

burst: period during which radio waves are intentionally transmitted, preceded and succeeded by periods during which no intentional transmission is made

environmental profile: declared range of environmental conditions under which equipment within the scope of the present document is required to be compliant

Eval_BW1: test condition where the pass band of a rectangular filter with a bandwidth of 4,75 MHz for 5 MHz equipment and 9,5 MHz for 10 MHz equipment is used for measurement centred on an operating channel or a victim channel

Eval_BW 2: measurement for EVAL_BW2 on the operating channel is performed using a rectangular filter with a 4,75 MHz or 9,5 MHz bandwidth and the measurement on the victim channel is performed using an RRC filter with a 3,84 MHz or 7,68 MHz bandwidth (respectively) both with roll-off factor of 0,22 centred on the 1st adjacent victim channel

integral antenna: antenna which is declared to be part of the radio equipment by the manufacturer

NOTE: Even when equipment with an integral antenna is concerned, it might still be possible to separate the antenna from the equipment using a special tool. In such cases the assessment of the radio equipment and of the antenna against requirements of this multi-part deliverable may be done separately.

maximum output power: mean power level per carrier of the base station or user equipment measured at the antenna connector in a specified reference condition

mean power: when applied to a modulated signal, this is the power (transmitted or received) in a bandwidth

NOTE: The term "mean" here is used to exclude the amplitude fluctuation related to those theoretical variations present in signal for example due to amplitude modulation, pulse shaping, pre-equalization, etc. Time averaging should be applied to estimate mean power with the affect of the theoretical variations. The duty cycle corresponding to burst activity within a frame should be also incorporated for "mean" power estimation.

nominal maximum output power: maximum nominal mean power level measured over total allocated channel bandwidth of the user equipment available at the antenna connector declared by the manufacturer; for equipment implementing dynamic change of modulation format, it is intended as the maximum nominal mean power associated to the modulation format delivering the highest power

operating nominal RF channel width: nominal amount of spectrum used by a single device operating on an identified centre frequency

receiver thermal noise power: equal to $k \times T \times BW \times F$

WiMAX: trademarked name for the OFDMA TDD WMAN IMT technology

3.2 Symbols

For the purposes of the present document, the following symbols apply:

A_{BS}	Base Station Interface A
A_{MS}	Mobile Station Interface A
A_{UUT}	Unit Under Test Interface A
dB	decibel
dBc	decibel relative to P_{nom} carrier power measured in Eval_BW1
dBm	decibel relative to 1 milliwatt
BW	Assigned channel bandwidth
f	Frequency of measurement
F_c	centre frequency of the assigned channel
F	Receiver noise figure
k	Boltzmann's constant
GHz	GigaHertz
M_{BS}	Base Station Interface M
MHz	MegaHertz
M_{MS}	Mobile Station Interface M
N	Maximum number of antennas in a multiple antenna configuration
N_{th}	Receiver thermal noise power expressed in dBm
P_{SENS}	Receiver sensitivity level at $BER \leq 10^{-6}$ (or equivalent PER) performance corresponding to the most robust modulation and coding rate supported by the technology
P_{nom}	declared nominal maximum output Power
P_{SENS5}	sensitivity levels at $BER \leq 10^{-6}$, for a 5 MHz channel, corresponding to the most robust modulation and coding rate supported by the technology
P_{SENS10}	sensitivity levels at $BER \leq 10^{-6}$, for a 10 MHz channel, corresponding to the most robust modulation and coding rate supported by the technology
T	Ambient temperature in Kelvin

3.3 Abbreviations

For the purposes of the present document, the following abbreviations apply:

ACLR	Adjacent Channel Leakage power Ratio
ACS	Adjacent Channel Selectivity
BER	Bit Error Ratio
BS	Base Station
BW	BandWidth
CW	Continuous Wave
ERM	Electromagnetic compatibility and Radio spectrum Matters
FDD	Frequency Division Duplexing
IMT	International Mobile Telecommunications
MSG	Mobile Standards Group
PER	Packet Error Ratio
RMS	Root Mean Square

R&TTE	Radio equipment and Telecommunications Terminal Equipment
RF	Radio Frequency
TFES	Task Force for European Standards for IMT
TPC	Transmit Power Control
UE	User Equipment
UUT	Unit Under Test
WMAN	Wireless Metropolitan Area Network

4 Essential requirements specification

With reference to article 3.2 of Directive 1999/5/EC [i.2] the phenomena in this clause have been identified as relevant to the essential requirements.

4.1 Environmental profile

The technical requirements of the present document apply under the environmental profile for operation of the equipment, which shall be declared by the manufacturer. The equipment shall comply with all the technical requirements of the present document at all times when operating within the boundary limits of the required operational environmental profile.

4.2 Conformance requirements

4.2.1 Introduction

To meet the essential requirement under article 3.2 of the R&TTE Directive [i.2] for IMT User Equipment (UE) six essential parameters in addition to those in EN 301 908-1 [1] have been identified. Table 4.2.1-1 provides a cross reference between these six essential parameters and the corresponding eleven technical requirements for equipment within the scope of the present document. To fulfil an essential parameter the compliance with all the corresponding technical requirements in table 4.2.1-1 must be verified.

Table 4.2.1-1: Cross references

Essential parameter	Corresponding technical requirements
Spectrum emission mask	4.2.2 Transmitter Spectrum emission mask
	4.2.3 Transmitter adjacent channel leakage power ratio
Conducted spurious emissions from the transmitter antenna connector	4.2.4 Transmitter spurious emissions
Accuracy of maximum output power	4.2.5 Transmitter maximum output power
Prevention of harmful interference through control of power	4.2.6 Transmitter minimum power control
Conducted spurious emissions from the receiver antenna connector	4.2.7 Receiver spurious emissions
Impact of interference on receiver performance	4.2.9 Receiver blocking characteristics
	4.2.10 Receiver intermodulation characteristics
	4.2.11 Receiver response rejection
Receiver adjacent channel selectivity	4.2.8 Receiver adjacent channel selectivity (ACS)
Control and Monitoring functions	4.2.4 Control and Monitoring functions

4.2.2 Transmitter spectrum emission mask

4.2.2.1 Definition

Spectrum emission mask defines an out of band emission requirement for the transmitter. These out of band emissions are unwanted emissions outside the channel bandwidth resulting from the modulation process and non-linearity in the transmitter but excluding spurious emissions.

4.2.2.2 Limits

A user equipment device transmitting on a single RF carrier configured in accordance with the manufacturer's specification shall meet the requirement. Emissions shall not exceed the maximum level specified in tables 4.2.2.2.1-1 and 4.2.2.2.2-1 for the appropriate UE maximum output power and nominal channel bandwidths of 5 MHz and 10 MHz.

Integration bandwidth refers to the frequency range over which the emission power is integrated.

Δf is defined as the frequency offset in MHz from the channel centre frequency.

4.2.2.2.1 Requirements for 5 MHz channel bandwidth

Table 4.2.2.2.1-1: Spectrum emission mask requirement

Segment number	Offset from channel centre frequency (Δf) (MHz)	Integration bandwidth (kHz)	Allowed emission level within the integration bandwidth (dBm)
1	2,5 to < 3,5	50	-13
2	3,5 to < 7,5	1 000	-10
3	7,5 to < 8,5	1 000	-13
4	8,5 to \leq 12,5	1 000	-25

4.2.2.2.2 Requirements for 10 MHz channel bandwidth

Table 4.2.2.2.2-1: Spectrum emission mask requirement

Segment number	Offset from channel centre frequency (Δf) (MHz)	Integration bandwidth (kHz)	Allowed emission level within the integration bandwidth (dBm)
1	5,0 to < 6,0	50	-13
2	6,0 to < 10	1 000	-10
3	10,0 to < 11,0	1 000	-13
4	11,0 to \leq 25,0	1 000	-25

4.2.2.3 Conformance

Conformance tests described in clause 5.4.1 shall be carried out.

4.2.3 Transmitter Adjacent Channel Leakage power Ratio (ACLR)

4.2.3.1 Definition

Adjacent Channel Leakage power Ratio (ACLR) is the ratio of the mean power measured through a filter pass band centred on the assigned channel frequency to the mean power measured through a filter pass band centred on the first adjacent channel. The filter pass band, response and nominal bandwidth are set according to Eval_BW 1 or Eval_BW 2.

4.2.3.2 Limits

4.2.3.2.1 ACLR requirements for 5 MHz bandwidth

For 5 MHz BW the ACLR shall be equal to or greater than the limits specified in table 4.2.3.2.1-1.

Table 4.2.3.2.1-1: User equipment ACLR limits for 5 MHz channel BW

Adjacent channel	ACLR limit relative to assigned channel frequency (dB)	
	ACLR limit for Eval_BW 1	ACLR limit for Eval_BW 2
$F_c \pm 5,0$ MHz	29,2	32,2
$F_c \pm 10,0$ MHz	43,2	42,2

4.2.3.2.2 ACLR requirements for 10 MHz bandwidth

For 10 MHz BW the ACLR shall be equal to or greater than the limits specified in table 4.2.3.2.2-1.

Table 4.2.3.2.2-1: User Equipment ACLR limits for 10 MHz Channel BW

Adjacent channel	ACLR limit relative to assigned channel frequency (dB)	
	ACLR limit for Eval_BW 1	ACLR limit for Eval_BW 2
$F_c \pm 10,0$ MHz	29,2	32,2
$F_c \pm 20,0$ MHz	43,2	42,2

4.2.3.3 Conformance

Conformance tests described in clause 5.4.2 shall be carried out.

4.2.4 Transmitter spurious emissions

4.2.4.1 Definition

Transmitter spurious emissions are emissions which are caused by unwanted transmitter effects such as harmonics emission, parasitic emission, intermodulation products and frequency conversion products, but exclude out of band emissions. This conducted measurement is measured at the RF output port. The spurious emission limits are specified in terms of general requirements in line with ITU-R Recommendation SM.329 10 [i.7] and frequency range specific requirements to address inter-system co-existence.

4.2.4.2 Limits

The limits of spurious emissions (or more precisely, according latest ITU-R definitions, unwanted emissions in the spurious domain), shall conform to CEPT/ERC Recommendation 74-01 [2].

The following requirements in tables 4.2.4.2.1-1, 4.2.4.2.2-1 and 4.2.4.2.2-2 are only applicable for frequencies, which are greater than 250 % of the channel bandwidth (that is 12,5 MHz for the 5 MHz channel bandwidth and 25 MHz for the 10 MHz channel bandwidth) away from the carrier centre frequency. In the following f_c is the centre frequency of transmit signal and f is the frequency of spurious emission. BW is the channel bandwidth of choice, i.e. 5 MHz or 10 MHz.

4.2.4.2.1 Requirements for 5 MHz channel bandwidth

Table 4.2.4.2.1-1: Spurious Emission requirement for 5 MHz channel bandwidth

Segment	Frequency Range	Measurement Bandwidth	Maximum allowed level (dBm)
1	$9 \text{ kHz} \leq f < 150 \text{ kHz}$	1 kHz	-36
2	$150 \text{ kHz} \leq f < 30 \text{ MHz}$	10 kHz	-36
3	$30 \text{ MHz} \leq f < 1\,000 \text{ MHz}$	100 kHz	-36
4	$1 \text{ GHz} \leq f < 12,75 \text{ GHz}$	30 kHz If $12,5 \text{ MHz} \leq f_c - f < 50 \text{ MHz}$ 300 kHz If $50 \text{ MHz} \leq f_c - f < 60 \text{ MHz}$ 1 MHz If $60 \text{ MHz} \leq f_c - f $	-30

4.2.4.2.2 Requirements for 10 MHz channel bandwidth

Table 4.2.4.2.2-1: Spurious Emission requirement for 10 MHz channel bandwidth

Segment	Frequency Range	Measurement Bandwidth	Maximum allowed level (dBm)
1	$9 \text{ kHz} \leq f < 150 \text{ kHz}$	1 kHz	-36
2	$150 \text{ kHz} \leq f < 30 \text{ MHz}$	10 kHz	-36
3	$30 \text{ MHz} \leq f < 1\,000 \text{ MHz}$	100 kHz	-36
4	$1 \text{ GHz} \leq f < 12,75 \text{ GHz}$	30 kHz If $25 \text{ MHz} \leq f_c - f < 100 \text{ MHz}$ 300 kHz If $100 \text{ MHz} \leq f_c - f < 120 \text{ MHz}$ 1 MHz If $120 \text{ MHz} \leq f_c - f $	-30

4.2.4.2.3 Requirements for UE coexistence

Table 4.2.4.2.3-1: Spurious Emission requirement for UE coexistence

Mobile WiMAX Band (MHz)	Protected Frequency band (MHz)	Measurement bandwidth	Maximum Emission Level (dBm)
880 to 915 1 710 to 1 785	791 to 821	1	-50
	925 to 960	1	-50
	1 805 to 1 880	1	-50
	1 880 to 1 920	1	-50
	1 900 to 1 920	1	-50
	2 010 to 2 025	1	-50
	2 110 to 2 170	1	-50
	2 300 to 2 400	1	-50
	2 570 to 2 690	1	-50

NOTE: As exceptions, measurements with a level up to the applicable requirements defined in table 4.2.4.2-1 are permitted for each assigned WiMAX carrier used in the measurement due to 2nd or 3rd harmonic spurious emissions. An exception is allowed if there is at least one individual sub carrier within the transmission bandwidth for which the 2nd or 3rd harmonic, i.e. the frequency equal to two or three times the frequency of that sub carrier is within the measurement bandwidth.

4.2.4.3 Conformance

Conformance tests described in clause 5.4.3 shall be carried out.

4.2.5 Transmitter Maximum Output Power

4.2.5.1 Definition

The UE maximum output power is measured over total allocated channel bandwidth available at the antenna connector.

4.2.5.2 Limits

The UE maximum output power shall not exceed 23 dBm.

4.2.5.3 Conformance

Conformance tests described in clause 5.4.4 shall be carried out.

4.2.6 Transmitter Minimum Output Power

4.2.6.1 Definition

The UE minimum output power is measured over total allocated channel bandwidth available at the antenna connector when the power is set to the minimum value.

4.2.6.2 Limits

The UE minimum output power shall not exceed -22 dBm.

4.2.6.3 Conformance

Conformance tests described in clause 5.4.4 shall be carried out.

4.2.7 Receiver spurious emissions

4.2.7.1 Definition

The receiver spurious emissions are the emissions generated or amplified in a receiver that appear at the UE antenna connector.

4.2.7.2 Limits

The limits of spurious emissions (or more precisely, according latest ITU-R definitions, unwanted emissions in the spurious domain), shall conform to CEPT/ERC Recommendation 74-01 [2].

Table 4.2.7.2-1 lists the receiver spurious emission requirements where f_c is the centre frequency of transmit signal and f is the frequency of spurious emission. BW is the channel bandwidth of choice, i.e. 5 MHz or 10 MHz.

Table 4.2.7.2-1: Receiver spurious emissions

Frequency band	Measurement bandwidth	Maximum Level
$30 \text{ MHz} \leq f < 1 \text{ GHz}$	100 kHz	-57 dBm
$1 \text{ GHz} \leq f \leq 12,75 \text{ GHz}$	1 MHz	-47 dBm

4.2.7.3 Conformance

Conformance tests described in clause 5.4.5 shall be carried out.

4.2.8 Receiver Adjacent Channel Selectivity (ACS)

4.2.8.1 Definition

The receiver adjacent and 2nd Adjacent Channel Selectivity (ACS) is a measure of the receiver's ability to receive a wanted signal at its assigned channel frequency in the presence of an adjacent channel signal at a given frequency offset from the centre frequency of the assigned channel. ACS is the interferer power level (in dB) relative to thermal noise (Nth).

To reference the receiver adjacent and 2nd adjacent channel selectivity values properly, a sensitivity level is defined as the signal level for Bit Error Ratio (BER) $\leq 10^{-6}$ (or equivalent PER) performance, over the channel bandwidth (5 MHz or 10 MHz), corresponding to the most robust modulation and coding rate supported by the technology.

N_{th} is the receiver thermal noise of the equipment as declared by the manufacturer and is equal to $kTBwF$ with Bw is the bandwidth of the equipment and F is the receiver noise figure.

4.2.8.2 Limits

Tables 4.2.8.2-1 and 4.2.8.2-2 specifies the limits and the test parameters for the receiver ACS in the first adjacent channel and 2nd adjacent channels for 5 MHz and 10 MHz channel bandwidths, respectively. For an assigned channel bandwidth of 5 MHz, an interferer channel bandwidth of 5 MHz is used and for an assigned channel bandwidth of 10 MHz, an interferer channel bandwidth of 10 MHz is used. The wanted and interferer power levels are evaluated over 95 % of the BW centred on the wanted or adjacent channel as identified in tables 4.2.8.2-1 or 4.2.8.2-2. The compliant system shall be able to meet a Bit Error Ratio (BER) $< 10^{-6}$ (or equivalent PER) with the interference levels specified in the tables. Alternatively depending on packet sizes supported, equivalent Packet Error Ratio (PER) criteria can be used.

Table 4.2.8.2-1: Limits and test parameters for receiver adjacent channel selectivity for 5 MHz channel bandwidth

Description	In-channel	Interferer on 1 st adjacent channel	Interferer on 2 nd adjacent channel
ACS limits (dB)		33	47
Power (dBm)	$P_{SENS} + 3$	$N_{th} + 33$	$N_{th} + 47$
Centre frequency (MHz)	f_c	$f_c \pm 5$ MHz	$f_c \pm 10$ MHz

Table 4.2.8.2-2: Limits and test parameters for receiver adjacent channel selectivity for 10 MHz channel bandwidth

Description	In-channel	Interferer on 1 st adjacent channel	Interferer on 2 nd adjacent channel
ACS limits (dB)		33	47
Power (dBm)	$P_{SENS} + 3$	$N_{th} + 33$	$N_{th} + 47$
Centre frequency (MHz)	f_c	$f_c \pm 10$ MHz	$f_c \pm 20$ MHz

4.2.8.3 Conformance

Conformance tests described in clause 5.4.6 shall be carried out.

4.2.9 Receiver blocking characteristics

4.2.9.1 Definition

The blocking characteristic is a measure of the receiver's ability to receive a wanted signal at its assigned channel frequency in the presence of an unwanted interferer on frequencies other than those of the spurious response or the adjacent channels, without this unwanted input signal causing a degradation of the performance of the receiver beyond a specified limit. The blocking performance shall apply to all frequencies except those at which a spurious response occur.

P_{SENS5} and P_{SENS10} are the sensitivity levels at BER $\leq 10^{-6}$, for 5 MHz and 10 MHz channels respectively, corresponding to the most robust modulation and coding rate supported by the user equipment. The wanted signal with the most robust modulation and coding supported by the UE shall be used.

4.2.9.2 Limits

The wanted signal with the most robust modulation and coding supported by the UE shall be used.

BER performance requirement at $BER \leq 10^{-6}$ (or equivalent PER) shall be met when the following signals are coupled to UE antenna input:

- A wanted signal at the assigned channel frequency, with mean power 6 dB above P_{SENS5} .
- Interfering signal with the following parameters.

Table 4.2.9.2-1: Receiver In-Band Blocking Limits for 5 MHz channel bandwidth

Centre frequency of interfering signal	Interfering signal mean power (dBm)	Wanted signal mean power (dB)	Minimum offset of interfering signal from the channel edge (MHz)	Type of interfering signal
925 to 960	-49	$P_{SENS5} + 6$	12,5	Modulation and coding equal to wanted signal
1 805 to 1 880	-49	$P_{SENS5} + 6$	12,5	Modulation and coding equal to wanted signal

BER performance requirement at $BER \leq 10^{-6}$ (or equivalent PER) shall be met when the following signals are coupled to UE antenna input:

- A wanted signal at the assigned channel frequency, with mean power 6 dB above P_{SENS10} .
- Interfering signal with the following parameters.

Table 4.2.9.2-2: Receiver In-Band Blocking Limits for 10 MHz channel bandwidth

Centre frequency of interfering signal	Interfering signal mean power (dBm)	Wanted signal mean power (dB)	Minimum offset of interfering signal from the channel edge (MHz)	Type of interfering signal
925 to 960	-49	$P_{SENS10} + 6$	25	Modulation and coding equal to wanted signal
1 805 to 1 880	-49	$P_{SENS10} + 6$	25	Modulation and coding equal to wanted signal

4.2.9.3 Conformance

Conformance tests described in clause 5.4.7 shall be carried out.

4.2.10 Receiver intermodulation characteristics

4.2.10.1 Definition and applicability

Third and higher order mixing of two interfering RF signals can produce an interfering signal in the band of the desired channel. Intermodulation response rejection is a measure of the capability of the receiver to receive a wanted signal on its assigned channel frequency in the presence of two or more interfering signals which have a specific frequency relationship to the wanted signal.

4.2.10.2 Limits

BER performance requirement at $BER \leq 10^{-6}$ (or equivalent PER) shall be met when the following signals are coupled to UE antenna input:

- A wanted signal at the assigned channel frequency, with mean power 6 dB above P_{SENS5} .
- Two interfering signals with the following parameters.

Table 4.2.10.2-1: Receiver intermodulation characteristics for 5 MHz channel bandwidth

Interfering signal mean power	Offset of interfering signal centre frequency from the channel edge	Type of interfering signal
-55 dBm	7,5 MHz	CW signal
-55 dBm	17,5 MHz	Modulation and coding equal to those of the wanted signal

BER performance requirement at $BER \leq 10^{-6}$ (or equivalent PER) shall be met when the following signals are coupled to UE antenna input.

- A wanted signal at the assigned channel frequency, with mean power 6 dB above P_{SENS10} .
- Two interfering signals with the following parameters.

Table 4.2.10.2-2: Receiver intermodulation characteristics for 10 MHz channel bandwidth

Interfering signal mean power	Minimum offset of interfering signal from the channel edge	Type of interfering signal
-55 dBm	15 MHz	CW signal
-55 dBm	35 MHz	Modulation and coding equal to those of the wanted signal

4.2.10.3 Conformance

Conformance tests described in clause 5.4.8 shall be carried out.

4.2.11 Receiver spurious response

4.2.11.1 Definition

Spurious response is a measure of the receiver's ability to receive a wanted signal on its assigned channel frequency without exceeding a given degradation due to the presence of an unwanted CW interfering signal at any other frequency at which a response is obtained i.e. for which the blocking limits as specified in tables 4.2.10.2-1 and 4.2.10.2-2 are not met.

4.2.11.2 Limits

BER performance requirement at $BER \leq 10^{-6}$ (or equivalent PER) shall be met when the following signals are coupled to UE antenna input.

- A wanted signal at the assigned channel frequency, with mean power 6 dB above P_{SENS5} .

Table 4.2.11.2-1: Receiver spurious response for 5 MHz channel bandwidth

Centre frequency of interfering signal (MHz)	Interfering signal mean power (dBm)	Wanted signal mean power (dB)	Minimum offset of interfering signal from the channel edge (MHz)	Type of interfering signal
925 to 960	-44	P _{SENS5} +6	10	Modulation and coding equal to wanted signal
1 805 to 1 880	-44	P _{SENS5} +6	10	Modulation and coding equal to wanted signal

BER performance requirement at $BER \leq 10^{-6}$ (or equivalent PER) shall be met when the following signals are coupled to UE antenna input.

- A wanted signal at the assigned channel frequency, with mean power 6 dB above P_{SENS10}.

Table 4.2.11.2-2: Receiver spurious response for 10 MHz channel bandwidth

Centre frequency of interfering signal (MHz)	Interfering signal mean power (dBm)	Wanted signal mean power (dB)	Minimum offset of interfering signal from the channel edge (MHz)	Type of interfering signal
925 to 960	-44	P _{SENS10} +6	20	Modulation and coding equal to wanted signal
1 805 to 1 880	-44	P _{SENS10} +6	20	Modulation and coding equal to wanted signal

4.2.11.3 Conformance

Conformance tests described in clause 5.4.9 shall be carried out.

5 Testing for compliance with technical requirements

5.1 Environmental conditions for testing

The technical requirements of the present document apply under the environmental profile, for intended operation of the equipment and antennas, declared by the manufacturer.

The environmental profile may be determined by the environmental class of the equipment according to the guidance given in EN 300 019-1-0 [i.4].

The combination of the equipment and its antennas shall comply with all the requirements of the present document at all times when operating within the boundary limits of the declared operational environmental profile.

5.2 Product information

The following information shall be stated by the manufacturer in order to carry out the test suites:

- the operating RF channel centre frequency range of the equipment;
- the nominal occupied channel bandwidth;
- the modulation format(s) employed by the equipment;
- the nominal maximum output power (P_{nom}) from the equipment and power class;
- the operational environmental profile(s) applicable to the equipment;

- the TPC range(s);
- the receiver sensitivity levels P_{SENS5} and P_{SENS10} ;
- The equipment receiver thermal noise power N_{th} (in dBm).

5.3 Interpretation of the measurement results

The interpretation of the results recorded in a test report for the measurements described in the present document shall be as follows:

- the measured value related to the corresponding limit shall be used to decide whether the user equipment meets the requirements of the present document;
- the value of the measurement uncertainty for the measurement of each parameter shall be documented in the test report;
- the recorded value of the measurement uncertainty shall be, for each measurement, equal to or lower than the figures in table 5.3-1.

For the test methods, according to the present document, the measurement uncertainty figures shall be calculated and shall correspond to an expansion factor (coverage factor) $k = 1,96$ (which provides a confidence level of 95 % in the case where the distributions characterizing the actual measurement uncertainties are normal (Gaussian)). Principles for the calculation of measurement uncertainty are contained in TR 100 028 [i.6] or TR 102 215 [i.5].

Table 5.3-1 is based on such expansion factors.

Table 5.3-1: Maximum measurement uncertainty of the test system

Parameter	Conditions	Uncertainty
Maximum output power tolerance		$\pm 0,7$ dB
Spectrum emission mask		$\pm 1,5$ dB
Transmitter adjacent channel leakage power ratio	-	$\pm 0,8$ dB
Transmitter spurious emissions	9 kHz < f ≤ 4 GHz: 4 GHz < f ≤ 12,75 GHz:	$\pm 2,0$ dB $\pm 4,0$ dB
Transmitter Minimum Output Power		$\pm 1,1$ dB
Receiver Adjacent Channel Selectivity		$\pm 1,0$ dB
Receiver Blocking Characteristics		$\pm 1,3$ dB
Receiver Spurious Response		$\pm 1,3$ dB
Receiver Intermodulation Characteristics		$\pm 1,4$ dB
Receiver spurious emissions	30 MHz ≤ f ≤ 4,0 GHz: 4 GHz < f ≤ 12,75 GHz:	$\pm 2,0$ dB $\pm 4,0$ dB
NOTE 1: For RF tests it should be noted that the uncertainties in table 5.3-1 apply to the test system operating into a nominal 50 Ω load and do not include system effects due to mismatch between the EUT and the test system.		
NOTE 2: If the test system for a test is known to have a measurement uncertainty greater than that specified in table 5.3-1, this equipment can still be used provided that an adjustment is made as follows: any additional uncertainty in the test system over and above that specified in table 5.3-1 should be used to tighten the test requirements - making the test more stringent to pass (for some tests, e.g. receiver tests, this may require modification of stimulus signals). This procedure will ensure that a test system not compliant with table 5.3-1 does not increase the probability of passing an EUT that would otherwise have failed a test if a test system compliant with table 5.3-1 had been used.		

5.4 Essential radio test suites

All tests are carried out under normal environmental conditions unless otherwise specified.

5.4.1 Transmitter Spectrum Emission Mask

The purpose of this test to verify compliance of UE equipment to the spectrum mask emission requirements of clause 4.2.2.

5.4.1.1 Method of measurement

Figure 5.4.1.1-1 shows the test setup for testing UE spectrum emission masks.

In the case that UE supports multiple transmit antenna (antenna 1 to N):

- 1) If single transmit antenna is a valid mode of operation, steps 1 to 7 shall be performed on a selected single antenna port with P_{nom} transmit level.
- 2) To test the mode with multiple antenna enabled:
 - a) Steps 1 to 7 shall be repeated when all antenna are enabled with a total transmit power of P_{nom} (e.g. each antenna is transmitting at $P_{nom} - 10 \times \log_{10} N$ level).
 - b) Step 4 is modified to include total combined power (measured power levels are added over N antenna).

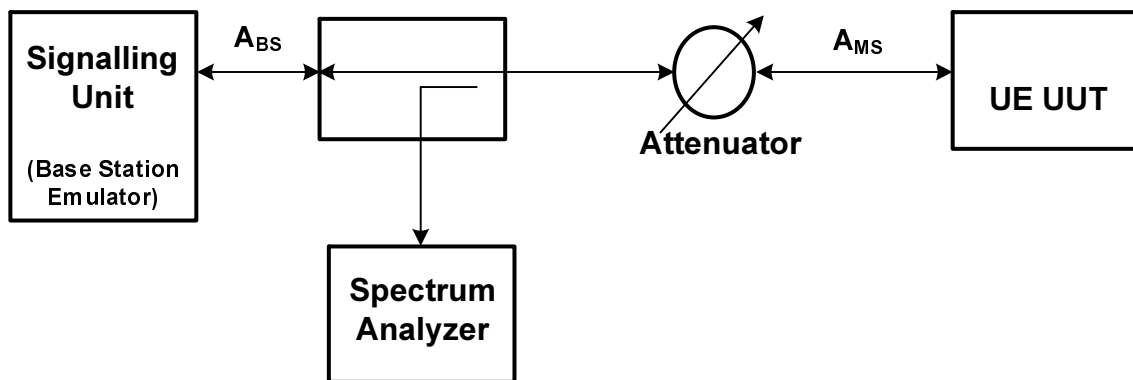

Figure 5.4.1.1-1: Test Setup for UE transmitter spectrum emission mask measurement

5.4.1.1.1 Initial conditions

The UUT shall be configured to operate at the P_{nom} level declared for the equipment.

For a UUT with antenna connector(s) and using external antenna(s), or for a UUT with integral antenna(s) but with a temporary antenna connector provided, conducted measurements shall be used.

For systems implementing dynamic change of the modulation order; this test shall be modified and executed accordingly to accurately capture transient behaviour. For example, if a system automatically operates at higher output power when lower order modulations are used, the test must correctly capture this effect. There may be a need for manufacturers to include information to identify the correct test conditions. The equipment shall be configured to operate with continuous modulation mode switching at the maximum switching speed permitted by the system, with equal duty cycle for all modulation orders, and with all training bursts or reference signals active as in normal operation.

5.4.1.1.2 Procedure

- Step 1 Set the RF channel to the lowest channel centre frequency from the declared range.
- Step 2 Make sure the data link connection has been established between UE UUT and Signaling Unit.
- Step 3 The spectrum analyzer must be correctly configured to measure the spectral mask. The UE UUT is configured to transmit at P_{nom} as measured over the 5 MHz or 10 MHz of allocated bandwidth. Measurements should only be conducted during the transmission.

- Step 4 Measure and note the signal spectrum over the range specified in clause 4.2.2.2. Table 4.2.2.2.1-1 (or table 4.2.2.2.2-1) according to the specified measurement bandwidths in the tables. Note that measurement aggregation is needed to compare with specified numbers according to the 1 MHz measurement bandwidth in the tables.
- Step 5 Repeat steps 3 and 4 at the middle and highest RF channel centre frequencies from the declared range.
- Step 6 Repeat steps 2 to 5 for all modulation schemes supported by the equipment under test.
- Step 7 End of test.

5.4.1.2 Test requirements

For the UE UUT the signal spectrum recorded in the steps above for each of the RF channel centre frequencies shall meet the requirements of clause 4.2.2.2 for the appropriate channel bandwidth supported.

5.4.2 Transmitter Adjacent Channel Leakage Power Ratio

The purpose of this test to verify compliance of UE equipment to the transmitter adjacent leakage power ratio requirements of clause 4.2.2.

5.4.2.1 Method of measurement

Figure 5.4.2.1-1 shows the test setup for testing UE ACLR.

In the case that UE supports multiple transmit antenna (antenna 1 to N):

- 1) If single transmit antenna is a valid mode of operation, steps 1 to 7 shall be performed on a selected single antenna port.
- 2) To test the mode with multiple antenna enabled:
 - a) Steps 1 to 7 shall be repeated when all antenna are enabled (e.g. each antenna is transmitting at $P_{nom} - 10 \times \log_{10} N$ level).
 - b) Step 4 is modified to include total combined power (measured power levels are added over N antenna).

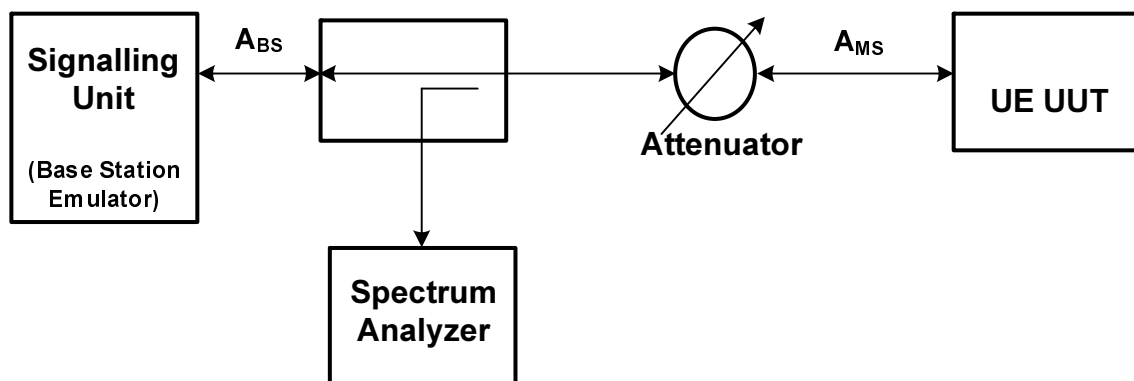

Figure 5.4.2.1-1: Test Setup for ACLR Testing of User Equipment

5.4.2.1.1 Initial conditions

The UUT shall be configured to operate at the P_{nom} level declared for the equipment under normal environmental conditions.

For a UUT with antenna connector(s) and using external antenna(s), or for a UUT with integral antenna(s) but with a temporary antenna connector provided, conducted measurements shall be used.

For systems implementing dynamic change of the modulation order, this test shall be modified and executed accordingly to accurately capture transient behaviour. For example, if a system automatically operates at higher output power when lower order modulations are used, the test must correctly capture this effect. There may be a need for manufacturers to include information to identify the correct test conditions. The equipment shall be configured to operate with continuous modulation mode switching at the maximum switching speed permitted by the system, with equal duty cycle for all modulation orders, and with all training bursts or reference signals active as in normal operation.

5.4.2.1.2 Procedure

- Step 1 Set the RF channel to the lowest channel centre frequency from the declared range.
- Step 2 Make sure the data link connection has been established between UE UUT and Signaling Unit.
- Step 3 The spectrum analyzer must be correctly configured to measure the aggregated power. The UE UUT is configured to transmit at P_{nom}. Measurements should only be conducted during the transmission.
- Step 4 Measure the aggregated power measured over a frequency range equal to 4,75 MHz and 9,5 MHz (for 5 MHz and 10 MHz cases respectively) centred on the assigned channel frequency.
- Step 5 Average over a sufficient number of transmitted bursts to obtain a stable reading.
- Step 6 Measure the aggregated power measured over a frequency range equal to 4,75 MHz and 9,5 MHz (for 5 MHz and 10 MHz cases respectively) for EVAL BW1 measurement and to 3,84 MHz and 7,68 MHz (for 5 MHz and 10 MHz cases respectively) for EVAL BW2 measurement centred on the first lower adjacent channel frequency which is 5 MHz (10 MHz for 10 MHz channel bandwidth) apart from operating RF channel centre frequency.
- Step 7 Average over a sufficient number of transmitted bursts to obtain a stable reading.
- Step 8 Calculate the ACLR by: (Power according to step 5) / (Power according to step 7).
- Step 9 Repeat steps 4 to 8 for the second adjacent (lower) RF channel (centre frequency 10 MHz for the 5 MHz channel bandwidth and 20 MHz for 10 MHz channel bandwidth, respectively, below the assigned channel frequency of the transmitted signal) and also for the first and second upper adjacent RF channel.
- Step 10 Run steps 2 to 9 at the middle and highest RF channel centre frequencies from the declared range.
- Step 11 Repeat steps 1 to 10 under extreme environmental conditions TL/VL, TL/VH, TH/VL and TH/VH. (See annex B.)
- Step 12 End of test.

5.4.2.2 Test requirements

For the UE UUT the maximum power levels recorded in the steps above and the ACLR calculation for each of the RF channel centre frequencies and environmental conditions shall meet the requirements of clause 4.2.3.2.

5.4.3 Transmitter spurious emissions

The purpose of this test to verify compliance of UE equipment to the transmitter spurious emission requirements of clause 4.2.4.

5.4.3.1 Method of measurement

Figure 5.4.3.1-1 shows the test setup for testing UE transmitter spurious emission requirement.

In the case that UE supports multiple transmit antenna (antenna 1 to N):

- 1) If single transmit antenna is a valid mode of operation, steps 1 to 6 shall be performed on a selected single antenna port with P_{nom} transmit level.

- 2) To test the mode with multiple antenna enabled:
- a) Steps 1 to 6 shall be repeated when all antenna are enabled (e.g. each antenna is transmitting at $P_{nom} - 10 \times \log_{10} N$ level).
 - b) Step 4 is modified to include total combined power (measured power levels are added over N antenna).

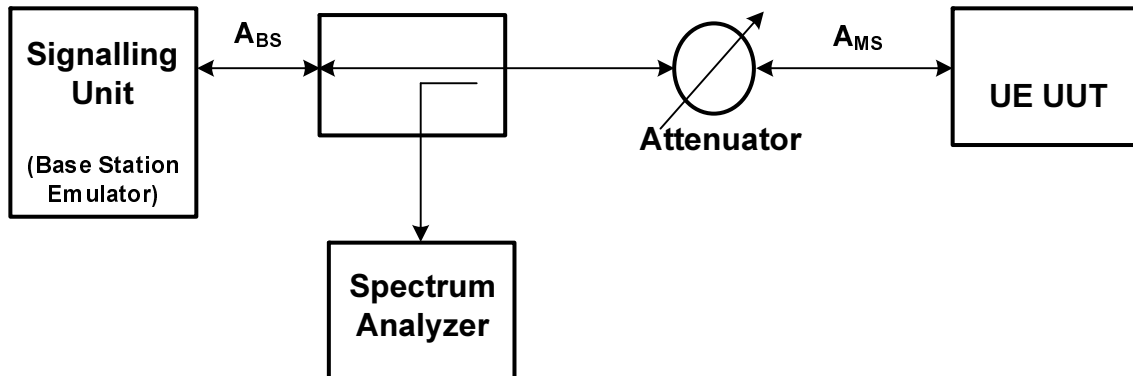

Figure 5.4.3.1-1: Test Setup for UE Transmitter spurious emission measurement

5.4.3.1.1 Initial conditions

The UUT shall be configured to operate at the P_{nom} level declared for the equipment.

For a UUT with antenna connector(s) and using external antenna(s), or for a UUT with integral antenna(s) but with a temporary antenna connector provided, conducted measurements shall be used.

In spectrum analyzer, set the measurement bandwidth as specified in the relevant tables 4.2.4.2.1-1, 4.2.4.2.2-1 and 4.2.4.2.2-2 of clause 4.2.4.2. Set the video bandwidth to value of three times the measurement bandwidth. True RMS detector shall be used.

For systems implementing dynamic change of the modulation order, the equipment shall be configured to operate with continuous modulation mode switching at the maximum switching speed permitted by the system, with equal duty cycle for all modulation orders, and with all training bursts or reference signals active as in normal operation.

5.4.3.1.2 Procedure

- Step 1 Set the RF channel at lowest channel centre frequency from the declared range.
- Step 2 Make sure the data link connection has been established between UE UUT and Signaling Unit.
- Step 3 The UE UUT is configured to transmit at its P_{nom} output power as measured over the 5 MHz or 10 MHz of allocated bandwidth.
- Step 4 Measure and note the UE transmitter spurious emissions over the range specified in clause 4.2.4.2, tables 4.2.4.2.1-1, 4.2.4.2.2-1 and 4.2.4.2.2-2 according to the specified measurement bandwidths in the tables.
- Step 5 Repeat steps 2 to 4 at middle and highest RF channel centre frequencies from the declared range.
- Step 6 End of test.

5.4.3.2 Test requirements

For the UE UUT the transmitter spurious emission levels recorded in the steps above for each of the RF channel centre frequencies shall meet the requirements of clause 4.2.4.2.

5.4.4 Transmitter Maximum and Minimum Output Power

The purpose of this test is to verify compliance of UE equipment transmitter maximum output power and minimum transmit power control in support of the requirements of clauses 4.2.5 and 4.2.6.

5.4.4.1 Method of measurement

Figure 5.4.4.1-1 shows the test setup for testing UE nominal maximum and minimum output transmitter power.

In the case that UE supports multiple transmit antenna (antenna 1 to N):

- 1) If single transmit antenna is a valid mode of operation, steps 1 to 9 below shall be performed on a selected single antenna port.
- 2) To test the mode with multiple antenna enabled:
 - a) Steps 1 to 9 below shall be repeated when all antenna are enabled (e.g. each antenna is transmitting at $P_{nom} - 10\log_{10}(N)$ level).
 - b) Step 4 is modified to include total combined power (measured power levels are added over N antenna).
 - c) Step 6 is modified to include total combined power (measured power levels are added over N antenna).

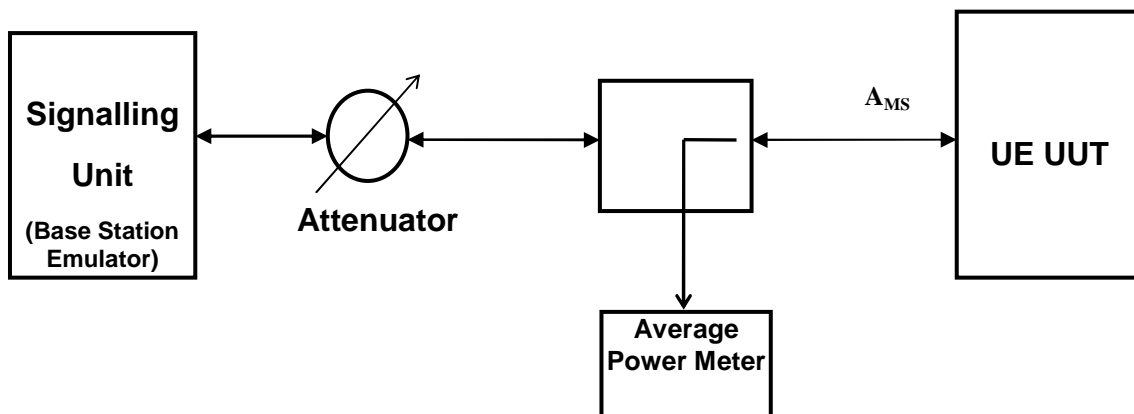

Figure 5.4.4.1-1: Test Setup for UE maximum and minimum transmitter output power

5.4.4.1.1 Initial conditions

The UUT shall be configured to operate at the P_{nom} level declared for the equipment under normal environmental conditions.

For a UUT with antenna connector(s) and using external antenna(s), or for a UUT with integral antenna(s) but with a temporary antenna connector provided, conducted measurements shall be used.

5.4.4.1.2 Procedure

- Step 1 Set the RF channel to the lowest channel centre frequency from the declared range.
- Step 2 Ensure the data link connection has been established between UE UUT and Signaling Unit.
- Step 3 The UE UUT shall be configured to continuously transmit at the declared P_{nom} .
- Step 4 Measure and note the measured power level for compliance with maximum output power in clause 4.2.5.
- Step 5 Configure the Signaling Unit to instruct the UE UUT to decrease the transmit power down to the point that the power cannot be reduced further.

- Step 6 Measure and note the measured power level for compliance with minimum output power in clause 4.2.6.
- Step 7 Repeat steps 3 to 6 at the middle and highest RF channel center frequencies from the declared range.
- Step 8 Repeat steps 2 to 7 for all modulation schemes supported by the UE UUT.
- Step 9 Repeat steps 1 to 8 under extreme environmental conditions TL/VL, TL/VH, TH/VL and TH/VH. (See annex B.)
- Step 10 End of test.

5.4.4.2 Test requirements

For the UE UUT the maximum and minimum power levels recorded in the steps above for each of the RF channel centre frequencies and environmental conditions shall meet the requirements of clauses 4.2.5 and 4.2.6.

5.4.5 Receiver spurious emissions

The purpose of this test to verify compliance of UE equipment to the transmitter spurious emission requirements of clause 4.2.8.

5.4.5.1 Method of measurement

Figure 5.4.5.1-1 shows the test setup for testing UE receiver spurious emission.

In the case that UE supports multiple transmit antenna (antenna 1 to N):

- 1) If single transmit antenna is a valid mode of operation, steps 1 to 6 shall be performed on a selected single antenna port with P_{nom} transmit level.
- 2) To test the mode with multiple antenna enabled:
 - a) Steps 1 to 6 shall be repeated when all antenna are enabled (e.g. each antenna is transmitting at $P_{nom} - 10 \times \log_{10} N$ level).
 - b) Step 3 is modified to include total combined power (measured power levels are added over N antenna).
 - c) Step 4 is modified to include total combined power (measured power levels are added over N antenna).

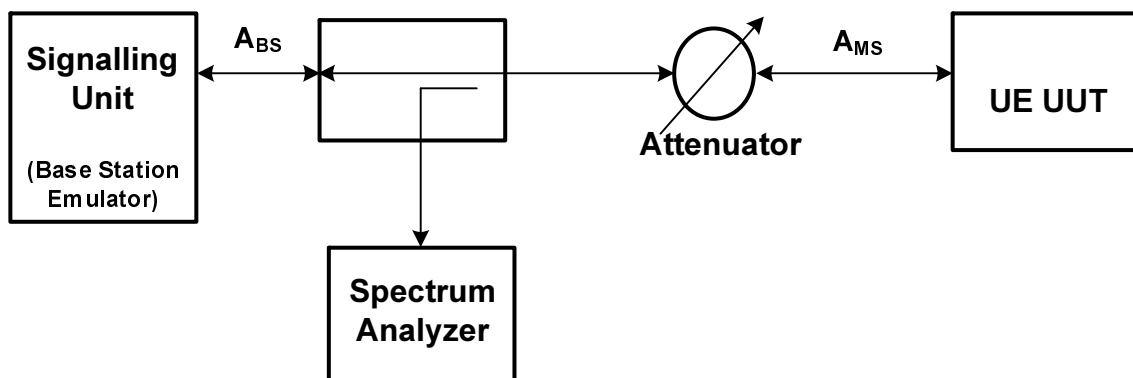

Figure 5.4.5.1-1: Test Setup for UE receiver spurious emission measurement

5.4.5.1.1 Initial conditions

For a UUT with antenna connector(s) and using external antenna(s), or for a UUT with integral antenna(s) but with a temporary antenna connector provided, conducted measurements shall be used.

In spectrum analyzer, set the measurement bandwidth as specified in the relevant table 4.2.7.2-1 of clause 4.2.7. Set the video bandwidth to value of three times the measurement bandwidth. True RMS detector shall be used.

5.4.5.1.2 Procedure

- Step 1 Set the RF channel at lowest channel centre frequency from the declared range.
- Step 2 Ensure the data link connection has been established between UE UUT and Signaling Unit.
- Step 3 The UE UUT is configured to transmit at its P_{nom} output power as measured over the 5 MHz or 10 MHz of allocated bandwidth.
- Step 4 Measure and note the UE receiver spurious emissions over the range specified in clause 4.2.7 table 4.2.7.2-1 according to the specified measurement bandwidths in the tables.
- Step 5 Repeat steps 2 to 4 at middle and highest RF channel center frequencies from the declared range.
- Step 6 End of test.

5.4.5.2 Test requirements

The results obtained shall be compared to the limits in clause 4.2.7.2 in order to show compliance.

5.4.6 Receiver Adjacent Channel Selectivity (ACS)

The purpose of this test to verify compliance of UE equipment to receiver adjacent channel selectivity requirements of clause 4.2.8.

5.4.6.1 Method of measurement

The interfering source shall be a conforming unsynchronized signal with the same signalling technology as the in-channel signal.

In the case that the UE supports multiple receive antennas (antenna 1 to N), a single channel is connected to the multiple antenna ports through a splitter. In this case, the test system is calibrated to the antenna ports to take into account splitter losses and identical signals and power levels ($\pm 0,3$ dB) are applied to each antenna port.

Figure 5.4.6.1-1 shows the test setup for testing UE receiver adjacent channel selectivity.

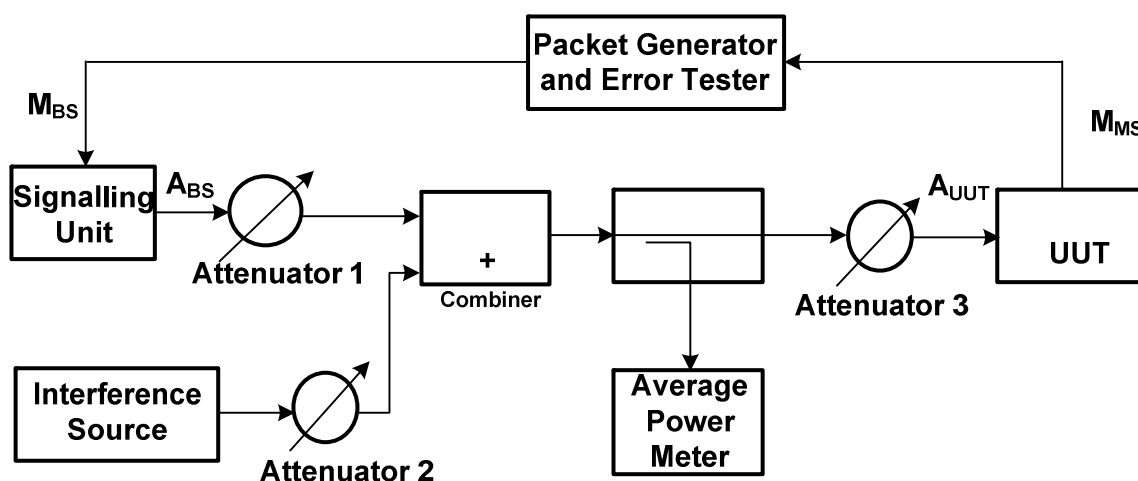

Figure 5.4.6.1-1: Test setup for UE receiver adjacent channel selectivity measurement

5.4.6.1.1 Initial conditions

Set the interfering source to the first adjacent channel operating frequency in accordance with tables 4.2.8.2-1 or 4.2.8.2-2. Set the interfering signal source bandwidth to be the same as the in-channel operating bandwidth. Turn the interfering source off.

5.4.6.1.2 Procedure

Test case for 5 MHz channel bandwidth

- Step 1 Set the UUT and signalling unit to the RF channel corresponding to the lowest channel centre frequency from the declared range.
- Step 2 Adjust the received signal level at A_{UUT} to be 3 dB above the sensitivity level P_{SENS5} for 5 MHz.
- Step 3 Turn on the interfering source and configure it to transmit at $F_c - 5$ MHz from the nominal (desired) operation frequency.
- Step 4 Increase the interfering source power to the interference level in table 4.2.8.2-1.
- Step 5 Perform a BER measurement and record the results.
- Step 6 Turn the interference source off.
- Step 7 Set the interfering source to the second adjacent channel operating frequency. Repeat steps 2 to 6 above for the test cases shown in table 4.2.9.2-1.
- Step 8 Reset the interfering source to the first adjacent channel operating frequency and repeat the steps 2 to 7 at the middle and highest RF channel centre frequencies from the declared frequency range.
- Step 9 End of test.

Test case for 10 MHz channel bandwidth

- Step 1 Set the UUT and signalling unit to the RF channel corresponding to the lowest channel centre frequency from the declared range.
- Step 2 Adjust the received signal level at A_{UUT} to be 3 dB above the sensitivity level P_{SENS10} for 10 MHz.
- Step 3 Turn on the interfering source and configure it to transmit at $F_c - 10$ MHz from the nominal (desired) operation frequency.
- Step 4 Increase the interfering source power to the interference level in table 4.2.8.2-2.
- Step 5 Perform a BER measurement and record the results.
- Step 6 Turn the interference source off.
- Step 7 Set the interfering source to the second adjacent channel operating frequency. Repeat steps 2 to 6 above for the test cases shown in table 4.2.8.2-2.
- Step 8 Reset the interfering source to the first adjacent channel operating frequency and repeat the steps 2 to 7 at the middle and highest RF channel centre frequencies from the declared frequency range.
- Step 9 End of test.

5.4.6.2 Test requirements

For the UE UUT the worst case BER measurement recorded in steps above for each of the RF channel centre frequencies shall meet the requirements of clause 4.2.8.2.

5.4.7 Receiver blocking characteristics

The purpose of this test is to verify compliance of UE equipment to the receiver blocking characteristics requirements of clause 4.2.9.

5.4.7.1 Method of measurement

The interfering source shall be a conforming unsynchronized signal with the same signalling technology as the in-channel signal.

In the case that the UE supports multiple receive antennas (antenna 1 to N), a single channel is connected to the multiple antenna ports through a splitter. In this case, the test system is calibrated to the antenna ports to take into account splitter losses and identical signals and power levels ($\pm 0,3$ dB) are applied to each antenna port.

Figure 5.4.7.1-1 shows the test setup of the receiver blocking test.

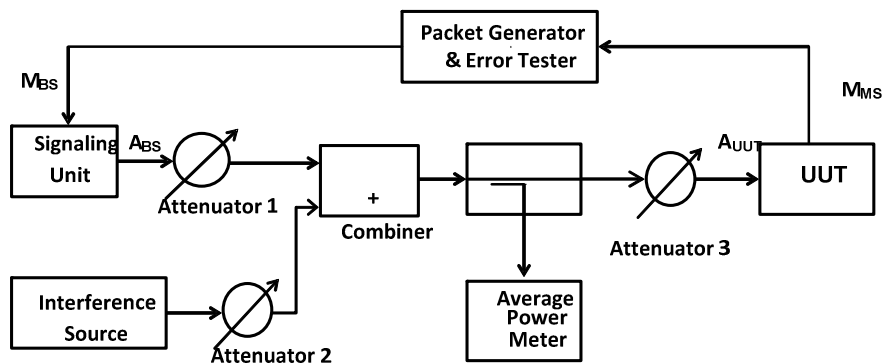

Figure 5.4.7.1-1: Test Setup for UE receiver blocking measurement

5.4.7.1.1 Initial conditions

Set the interfering signal source bandwidth to be the same as the in-channel operating bandwidth and operating on an interfering source centre frequency in accordance with tables 4.2.9.2-1 or 4.2.9.2-2 according to the system channel bandwidth under test. Set the interfering signal mean power to the level identified in tables 4.2.9.2-1 or 4.2.9.2-2.

Turn the interfering source off.

5.4.7.1.2 Procedure

- Step 1 Set the UUT and signalling unit to the RF channel corresponding to the lowest channel centre frequency from the declared range.
- Step 2 Adjust the received signal level at A_{UUT} to be 6 dB above the sensitivity level P_{SENS5} or P_{SENS10} .
- Step 3 Turn on the interfering source.
- Step 4 Step the interfering signal generator frequency through the frequency range indicated in tables 4.2.9.2-1 or 4.2.9.2-2 according to the system channel bandwidth under test, with a step size of 1 MHz.
- Step 5 Measure the BER of the desired signal received for each step of the interfering frequency and record the results.
- Step 6 Record any interfering signal centre frequency at which the blocking requirement is not met.
- Step 7 Turn the interference source off.
- Step 8 Repeat the test procedure at middle and highest channel centre frequencies for the desired received signal from the declared range.

Step 9 End of test.

5.4.7.2 Test requirements

For the UE UUT the worst case BER measurement recorded in the steps above for each step of the interfering signal and at each of the RF channel centre frequencies shall meet the requirements of clause 4.2.9.2.

5.4.8 Receiver intermodulation characteristics

The purpose of this test is to verify compliance of UE equipment to the receiver intermodulation characteristic requirements of clause 4.2.10.

5.4.8.1 Method of measurement

Interfering sources shall consist of a CW signal and a conforming unsynchronized signal with the same signalling technology as the in-channel signal.

In the case that the UE supports multiple receive antennas (antenna 1 to N), a single channel is connected to the multiple antenna ports through a splitter. In this case, the test system is calibrated to the antenna ports to take into account splitter losses and identical signals and power levels ($\pm 0,3$ dB) are applied to each antenna port.

Figure 5.4.8.1-1 shows the test setup for the receiver intermodulation test.

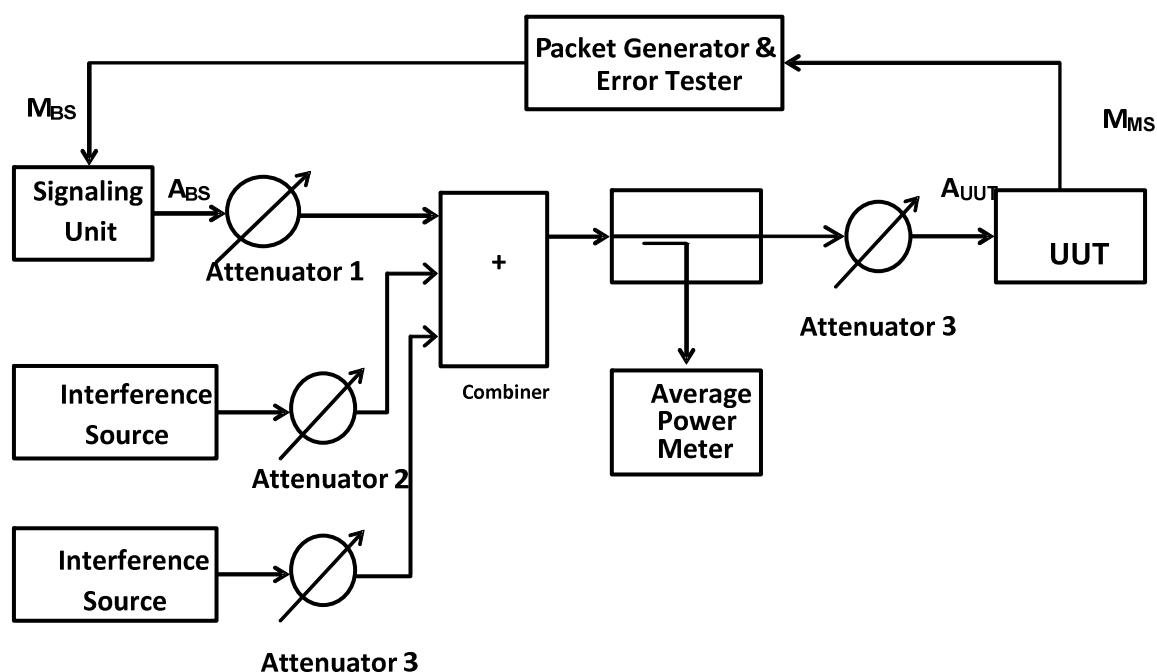

Figure 5.4.8.1-1: Test setup for receiver intermodulation response measurement

5.4.8.1.1 Initial conditions

Set the modulated interfering signal source bandwidth to be the same as the in-channel operating bandwidth. Set the interfering source centre frequency to have a positive frequency offset from the upper wanted channel edge in accordance with tables 4.2.10.2-1 or 4.2.10.2-2 according to the system channel bandwidth under test. Set the modulated interfering signal mean power to the level identified in tables 4.2.10.2-1 or 4.2.10.2-2 according to the system channel bandwidth under test.

Set the CW interfering signal frequency to have a positive frequency offset from the upper wanted channel edge in accordance with tables 4.2.10.2-1 or 4.2.10.2-2 according to the system channel bandwidth under test. Set the CW interfering signal mean power to the level identified in tables 4.2.10.2-1 or 4.2.10.2-2 according to the system channel bandwidth under test.

Turn the interfering sources off.

5.4.8.1.2 Procedure

- Step 1 Set the UUT and signalling unit to the RF channel corresponding to the lowest channel centre frequency from the declared range.
- Step 2 Adjust the received signal level at A_{UUT} to be 6 dB above the sensitivity level $P_{SENS} + 6$ dB. Note the signal level is measured over the time period of the data burst only within the downlink transmission.
- Step 3 Turn on the interfering sources.
- Step 4 Measure the BER of the desired signal received and record the results.
- Step 5 Turn the interfering sources off.
- Step 6 Reconfigure the interfering sources to transmit with negative frequency offsets from the lower wanted channel edge as defined in tables 4.2.10.2-1 or 4.2.10.2-2 according to the system channel bandwidth under test.
- Step 7 Turn on the interfering sources.
- Step 8 Measure the BER of the desired signal received and record the results.
- Step 9 Turn the interfering sources off.
- Step 10 Repeat the test procedure at middle and highest channel centre frequencies for the desired received signal from the declared range.
- Step 11 End of test.

5.4.8.2 Test requirements

For the UE UUT the worst case BER measurement recorded in the steps above for each of the RF channel centre frequencies shall meet the requirements of clause 4.2.10.2.

5.4.9 Receiver spurious response

The purpose of this test is to verify compliance of UE equipment to the receiver spurious response requirements of clause 4.2.11.

5.4.9.1 Method of measurement

The interfering source shall consist of a CW signal. Test frequencies for the desired signal and CW interferer shall be defined from those exceptions declared during execution of the receiver blocking test.

In the case that the UE supports multiple receive antennas (antenna 1 to N), a single channel is connected to the multiple antenna ports through a splitter. In this case, the test system is calibrated to the antenna ports to take into account splitter losses and identical signals and power levels ($\pm 0,3$ dB) are applied to each antenna port.

Figure 5.4.9.1-1 shows the test setup for the receiver spurious response test.

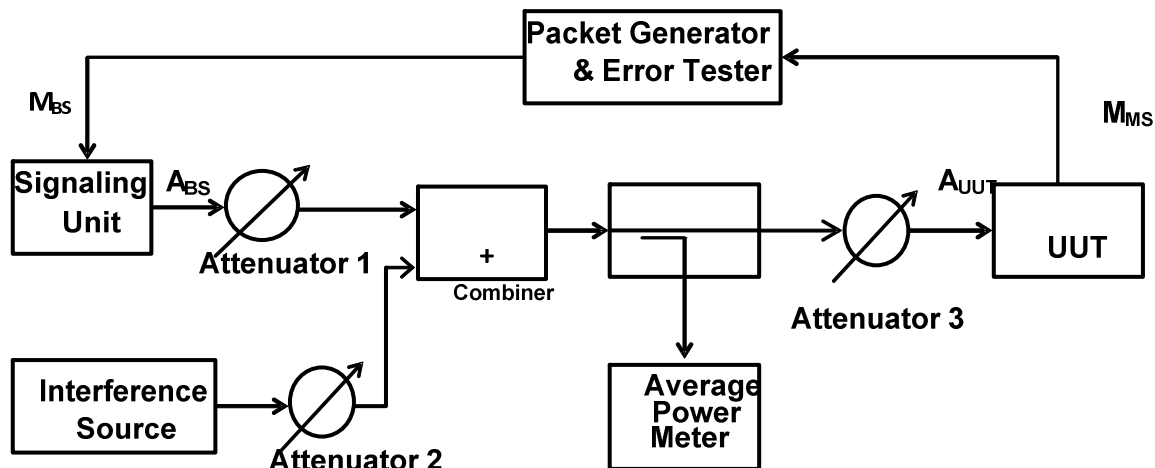

Figure 5.4.9.1-1: Test setup for receiver spurious response measurement

5.4.9.1.1 Initial conditions

Set the desired received signal BW to the signal BW used in the receiver blocking test, as described in clause 5.4.8.1 at which the blocking test failed.

5.4.9.1.2 Procedure

- Step 1 Set the desired received signal frequency to the frequency used for the receiver blocking test, as described in clause 5.4.7.1.1 at which the blocking test requirements were not met.
- Step 2 Adjust the received signal level at A_{UUT} to be 6 dB above the sensitivity level P_{SENS5} or P_{SENS10} according to the channel bandwidth under test. Note the signal level is measured over the time period of the data burst only within the downlink transmission.
- Step 3 Set the frequency of the interferer signal according the recorded spurious response frequency values obtained from the blocking test as described in clause 5.4.7.1.2 step 6 at which the blocking test requirements were not met.
- Step 4 Set the power level of the interferer according to either tables 4.2.11.2-1 or 4.2.11.2-2 as appropriate.
- Step 5 Measure the BER of the desired signal received for each frequency of the interferer signal and record the results.
- Step 6 Repeat the test procedure at all frequencies which the blocking test requirements were not met.
- Step 7 End of test.

5.4.9.2 Test requirements

For the UE UUT the measured receiver spurious emission levels recorded in the steps above for each of the RF channel centre frequencies shall meet the requirements of clause 4.2.11.2.

Annex A (normative): HS Requirements and conformance Test specifications Table (HS-RTT)

The HS Requirements and conformance Test specifications Table (HS-RTT) in table A-1 serves a number of purposes, as follows:

- it provides a statement of all the requirements in words and by cross reference to (a) specific clause(s) in the present document or to (a) specific clause(s) in (a) specific referenced document(s);
- it provides a statement of all the test procedures corresponding to those requirements by cross reference to (a) specific clause(s) in the present document or to (a) specific clause(s) in (a) specific referenced document(s);
- it qualifies each requirement to be either:
 - Unconditional: meaning that the requirement applies in all circumstances; or
 - Conditional: meaning that the requirement is dependent on the manufacturer having chosen to support optional functionality defined within the schedule.
- in the case of Conditional requirements, it associates the requirement with the particular optional service or functionality;
- it qualifies each test procedure to be either:
 - Essential: meaning that it is included with the Essential Radio Test Suite and therefore the requirement shall be demonstrated to be met in accordance with the referenced procedures;
 - Other: meaning that the test procedure is illustrative but other means of demonstrating compliance with the requirement are permitted.

Table A-1: HS Requirements and conformance Test specifications Table (HS-RTT)

Harmonized Standard EN 301 908-21						
The following requirements and test specifications are relevant to the presumption of conformity under the article 3.2 of the R&TTE Directive [i.2]						
Requirement			Requirement Conditionality		Test Specification	
No	Description	Reference: Clause No	U/C	Condition	E/O	Reference: Clause No
1	Transmitter Spectrum Emission Mask	4.2.2	U		E	5.4.1
2	Transmitter Adjacent Channel Leakage Power Ratio	4.2.3	U		E	5.4.2
3	Transmitter Spurious Emissions	4.2.4	U		E	5.4.3
4	Transmitter Maximum Output Power	4.2.5	U		E	5.4.4
5	Transmitter Minimum Output Power	4.2.6	U		E	5.4.4
6	Receiver Spurious Emissions	4.2.7	U		E	5.4.5
7	Receiver Adjacent Channel Selectivity (ACS)	4.2.8	U		E	5.4.6
8	Receiver Blocking Characteristics	4.2.9	U		E	5.4.7
9	Receiver Intermodulation Characteristics	4.2.10	U		E	5.4.8
10	Receiver Spurious Response	4.2.11	U		E	5.4.9

Key to columns:**Requirement:**

No A unique identifier for one row of the table which may be used to identify a requirement or its test specification.

Description A textual reference to the requirement.

Clause Number Identification of clause(s) defining the requirement in the present document unless another document is referenced explicitly.

Requirement Conditionality:

U/C Indicates whether the requirement is to be *unconditionally* applicable (U) or is *conditional* upon the manufacturers claimed functionality of the equipment (C).

Condition Explains the conditions when the requirement shall or shall not be applicable for a technical requirement which is classified "conditional".

Test Specification:

E/O Indicates whether the test specification forms part of the Essential Radio Test Suite (E) or whether it is one of the Other Test Suite (O).

NOTE: All tests whether "E" or "O" are relevant to the requirements. Rows designated "E" collectively make up the Essential Radio Test Suite; those designated "O" make up the Other Test Suite; for those designated "X" there is no test specified corresponding to the requirement. The completion of all tests classified "E" as specified with satisfactory outcomes is a necessary condition for a presumption of conformity. Compliance with requirements associated with tests classified "O" or "X" is a necessary condition for presumption of conformity, although conformance with the requirement may be claimed by an equivalent test or by manufacturer's assertion supported by appropriate entries in the technical construction file.

Clause Number Identification of clause(s) defining the test specification in the present document unless another document is referenced explicitly. Where no test is specified (that is, where the previous field is "X") this field remains blank.

Annex B (normative): Environmental profile specification

The following environmental conditions may be declared by the manufacturer:

- barometric pressure: minimum and maximum;
- temperature: normal and minimum/maximum extremes;
- relative humidity: maximum;
- power supply: normal and lower/upper voltage extremes.

Where an extreme environment is required then the various combinations of extreme temperatures together with the extreme voltages are shown below:

- Low extreme Temperature/Low extreme Voltage (TL/VL);
- Low extreme Temperature/High extreme Voltage (TL/VH);
- High extreme Temperature/Low extreme Voltage (TH/VL);
- High extreme Temperature/High extreme Voltage (TH/VH).

Annex C (informative): The EN title in the official languages

The enlargement of the European Union (EU) resulted in a requirement from the EU for a larger number of languages for the translation of the titles of Harmonized Standards and mandated ENs that are to be listed in the Official Journal to support the implementation of this legislation.

For this reason the title translation concerning the present document can be consulted via the [e-approval](#) application.

Annex D (informative): Bibliography

- Directive 2004/108/EC of the European Parliament and of the Council of 15 December 2004 on the approximation of the laws of the Member States relating to electromagnetic compatibility and repealing Directive 89/336/EEC (EMC Directive).
- ETSI TS 125 104: "Universal Mobile Telecommunications System (UMTS); Base Station (BS) radio transmission and reception (FDD) (3GPP TS 25.104)".
- Directive 2006/95/EC of the European Parliament and of the Council of 12 December 2006 on the harmonisation of the laws of Member States relating to electrical equipment designed for use within certain voltage limits (LV Directive).
- WiMAX Forum® Air Interface specifications; WiMAX Forum® T23-005-R015v05.

History

Document history		
V5.1.1	February 2011	Public Enquiry PE 20110607: 2011-02-07 to 2011-06-07
V5.2.1	July 2011	Vote V 20110911: 2011-07-13 to 2011-09-12