

ETSI EN 301 908-20 V6.2.1 (2013-06)



**IMT cellular networks;
Harmonized EN covering the essential requirements
of article 3.2 of the R&TTE Directive;
Part 20: OFDMA TDD WMAN (Mobile WiMAX)
TDD Base Stations (BS)**

Reference

REN/MSG-TFES-010-20

Keywords

broadband, IMT, IMT-2000, mobile, OFDMA,
radio, regulation, TDD, WiMAX, WMAN

ETSI

650 Route des Lucioles
F-06921 Sophia Antipolis Cedex - FRANCE

Tel.: +33 4 92 94 42 00 Fax: +33 4 93 65 47 16

Siret N° 348 623 562 00017 - NAF 742 C
Association à but non lucratif enregistrée à la
Sous-Préfecture de Grasse (06) N° 7803/88

Important notice

Individual copies of the present document can be downloaded from:

<http://www.etsi.org>

The present document may be made available in more than one electronic version or in print. In any case of existing or perceived difference in contents between such versions, the reference version is the Portable Document Format (PDF). In case of dispute, the reference shall be the printing on ETSI printers of the PDF version kept on a specific network drive within ETSI Secretariat.

Users of the present document should be aware that the document may be subject to revision or change of status.

Information on the current status of this and other ETSI documents is available at

<http://portal.etsi.org/tb/status/status.asp>

If you find errors in the present document, please send your comment to one of the following services:

http://portal.etsi.org/chaicor/ETSI_support.asp

Copyright Notification

No part may be reproduced except as authorized by written permission.
The copyright and the foregoing restriction extend to reproduction in all media.

© European Telecommunications Standards Institute 2013.
All rights reserved.

DECT™, PLUGTESTS™, UMTS™ and the ETSI logo are Trade Marks of ETSI registered for the benefit of its Members.
3GPP™ and LTE™ are Trade Marks of ETSI registered for the benefit of its Members and
of the 3GPP Organizational Partners.

GSM® and the GSM logo are Trade Marks registered and owned by the GSM Association.

Contents

| | |
|---|----|
| Intellectual Property Rights | 6 |
| Foreword..... | 6 |
| Introduction | 6 |
| 1 Scope | 7 |
| 2 References | 7 |
| 2.1 Normative references | 7 |
| 2.2 Informative references..... | 8 |
| 3 Definitions, symbols and abbreviations | 8 |
| 3.1 Definitions..... | 8 |
| 3.2 Symbols..... | 9 |
| 3.3 Abbreviations | 9 |
| 4 Essential requirements specification | 10 |
| 4.1 Environmental profile..... | 10 |
| 4.2 Conformance requirements | 10 |
| 4.2.1 Introduction..... | 10 |
| 4.2.2 Transmitter Spectrum Emission Mask..... | 10 |
| 4.2.2.1 Definition | 10 |
| 4.2.2.2 Limits | 11 |
| 4.2.2.2.1 Spectrum emission mask for 5 MHz channel bandwidth - BCI 1.B and 3.A | 11 |
| 4.2.2.2.2 Spectrum emission mask for 10 MHz channel bandwidth - BCI 1.B and 3.A | 11 |
| 4.2.2.2.3 Spectrum emission mask for BCI 5L.A, 5L.C, 5H.A and 5H.C..... | 11 |
| 4.2.2.3 Conformance..... | 11 |
| 4.2.3 Transmitter Adjacent Channel Leakage power Ratio (ACLR)..... | 12 |
| 4.2.3.1 Definition | 12 |
| 4.2.3.2 Limits | 12 |
| 4.2.3.2.1 ACLR requirements for 5 MHz channel bandwidth..... | 12 |
| 4.2.3.2.2 ACLR requirements for 10 MHz channel bandwidth..... | 13 |
| 4.2.3.3 Conformance..... | 13 |
| 4.2.4 Transmitter spurious emissions..... | 13 |
| 4.2.4.1 Definition | 13 |
| 4.2.4.2 Limits | 13 |
| 4.2.4.2.1 General requirements..... | 13 |
| 4.2.4.2.2 Additional Spurious Emission Requirements | 14 |
| 4.2.4.3 Conformance..... | 15 |
| 4.2.5 Base station maximum output power..... | 15 |
| 4.2.5.1 Definition | 15 |
| 4.2.5.2 Limits | 15 |
| 4.2.5.3 Conformance..... | 15 |
| 4.2.6 Transmit intermodulation | 15 |
| 4.2.6.1 Definition | 15 |
| 4.2.6.2 Limits | 15 |
| 4.2.6.3 Conformance..... | 15 |
| 4.2.7 Receiver spurious emissions | 16 |
| 4.2.7.1 Definition | 16 |
| 4.2.7.2 Limits | 16 |
| 4.2.7.3 Conformance..... | 16 |
| 4.2.8 Receiver blocking characteristics | 16 |
| 4.2.8.1 Definition | 16 |
| 4.2.8.2 Limits | 16 |
| 4.2.8.3 Conformance..... | 18 |
| 4.2.9 Receiver intermodulation characteristics | 18 |
| 4.2.9.1 Definition | 18 |
| 4.2.9.2 Limits | 18 |

| | | |
|-----------------------------|--|-----------|
| 4.2.9.3 | Conformance | 19 |
| 4.2.10 | Receiver Adjacent Channel Selectivity..... | 19 |
| 4.2.10.1 | Definition | 19 |
| 4.2.10.2 | Limits | 19 |
| 4.2.10.3 | Conformance..... | 19 |
| 5 | Testing for compliance with technical requirements..... | 20 |
| 5.1 | Environmental conditions for testing | 20 |
| 5.2 | Product information..... | 20 |
| 5.3 | Interpretation of the measurement results | 20 |
| 5.4 | Essential radio test suites..... | 21 |
| 5.4.1 | Transmitter Spectrum Emission Mask..... | 21 |
| 5.4.1.1 | Method of measurement..... | 21 |
| 5.4.1.1.1 | Initial conditions | 22 |
| 5.4.1.1.2 | Procedure..... | 22 |
| 5.4.1.2 | Test requirements | 22 |
| 5.4.2 | Transmitter Adjacent Channel Leakage Power Ratio (ACLR)..... | 22 |
| 5.4.2.1 | Method of measurement..... | 23 |
| 5.4.2.1.1 | Initial conditions | 23 |
| 5.4.2.1.2 | Procedure..... | 23 |
| 5.4.2.2 | Test requirements | 24 |
| 5.4.3 | Transmitter spurious emissions..... | 24 |
| 5.4.3.1 | Method of measurement..... | 24 |
| 5.4.3.1.1 | Initial conditions | 25 |
| 5.4.3.1.2 | Procedure..... | 25 |
| 5.4.3.2 | Test requirements | 25 |
| 5.4.4 | Base Station maximum output power | 25 |
| 5.4.4.1 | Method of measurement..... | 25 |
| 5.4.4.1.1 | Initial conditions | 26 |
| 5.4.4.1.2 | Procedure..... | 26 |
| 5.4.4.2 | Test requirements | 26 |
| 5.4.5 | Transmit Intermodulation | 26 |
| 5.4.5.1 | Method of measurement..... | 26 |
| 5.4.5.1.1 | Initial conditions | 27 |
| 5.4.5.1.2 | Procedure..... | 27 |
| 5.4.5.2 | Test requirements | 27 |
| 5.4.6 | Receiver spurious emissions | 27 |
| 5.4.6.1 | Method of measurement..... | 27 |
| 5.4.6.1.1 | Initial conditions | 28 |
| 5.4.6.1.2 | Procedure..... | 28 |
| 5.4.6.2 | Test requirements | 28 |
| 5.4.7 | Receiver blocking characteristics | 28 |
| 5.4.7.1 | Method of Measurement | 28 |
| 5.4.7.1.1 | Initial conditions | 29 |
| 5.4.7.1.2 | Procedure..... | 29 |
| 5.4.7.2 | Test requirements | 30 |
| 5.4.8 | Receiver Intermodulation characteristics..... | 30 |
| 5.4.8.1 | Method of measurement..... | 30 |
| 5.4.8.1.1 | Initial conditions | 30 |
| 5.4.8.1.2 | Procedure..... | 31 |
| 5.4.8.2 | Test requirements | 31 |
| 5.4.9 | Receiver adjacent channel selectivity | 31 |
| 5.4.9.1 | Method of measurement..... | 31 |
| 5.4.9.1.1 | Initial conditions | 32 |
| 5.4.9.1.2 | Procedure..... | 32 |
| 5.4.9.2 | Test requirements | 32 |
| Annex A (normative): | HS Requirements and conformance Test specifications Table (HS-RTT)..... | 33 |
| Annex B (normative): | Environmental profile | 35 |

| | | |
|-------------------------------|---------------------------|-----------|
| Annex C (informative): | Void | 36 |
| Annex D (informative): | Bibliography | 37 |
| History | | 38 |

Intellectual Property Rights

IPRs essential or potentially essential to the present document may have been declared to ETSI. The information pertaining to these essential IPRs, if any, is publicly available for **ETSI members and non-members**, and can be found in ETSI SR 000 314: "*Intellectual Property Rights (IPRs); Essential, or potentially Essential, IPRs notified to ETSI in respect of ETSI standards*", which is available from the ETSI Secretariat. Latest updates are available on the ETSI Web server (<http://ipr.etsi.org>).

Pursuant to the ETSI IPR Policy, no investigation, including IPR searches, has been carried out by ETSI. No guarantee can be given as to the existence of other IPRs not referenced in ETSI SR 000 314 (or the updates on the ETSI Web server) which are, or may be, or may become, essential to the present document.

Foreword

This Harmonized European Standard (EN) has been produced by ETSI Technical Committee Mobile Standards Group (MSG).

The present document has been produced by ETSI in response to a mandate from the European Commission issued under Directive 98/34/EC [i.1] as amended by Directive 98/48/EC [i.8].

The title and reference to the present document are intended to be included in the publication in the Official Journal of the European Union of titles and references of Harmonized Standard under the Directive 1999/5/EC [i.2].

See article 5.1 of Directive 1999/5/EC [i.2] for information on presumption of conformity and Harmonised Standards or parts thereof the references of which have been published in the Official Journal of the European Union.

The requirements relevant to Directive 1999/5/EC [i.2] are summarized in annex A.

The present document is part 20 of a multi-part deliverable. Full details of the entire series can be found in part 1 [1].

| National transposition dates | |
|--|-------------------|
| Date of adoption of this EN: | 10 June 2013 |
| Date of latest announcement of this EN (doa): | 30 September 2013 |
| Date of latest publication of new National Standard or endorsement of this EN (dop/e): | 31 March 2014 |
| Date of withdrawal of any conflicting National Standard (dow): | 31 March 2015 |

Introduction

The present document is part of a set of standards developed by ETSI and is designed to fit in a modular structure to cover all radio and telecommunications terminal equipment within the scope of the R&TTE Directive [i.2]. The modular structure is shown in EG 201 399 [i.3].

1 Scope

The present document applies to the following radio equipment type:

- Base stations for IMT-2000 OFDMA TDD WMAN (Mobile WiMAX) operating in TDD mode.

This radio equipment type is capable of operating in all or any part of the frequency bands given in table 1-1.

Table 1-1: OFDMA TDD WMAN Base Station frequency bands

| Mobile WiMAX Band Class Index | IMT-2000 OFDMA TDD WMAN service operating bands | Channel Bandwidth; BW |
|-------------------------------|---|-----------------------|
| 1.B | 2 300 MHz to 2 400 MHz | 5 MHz and 10 MHz |
| 3.A | 2 500 MHz to 2 690 MHz | 5 MHz and 10 MHz |
| 5L.A | 3 400 MHz to 3 600 MHz | 5 MHz |
| 5L.C | 3 400 MHz to 3 600 MHz | 10 MHz |
| 5H.A | 3 600 MHz to 3 800 MHz | 5 MHz |
| 5H.C | 3 600 MHz to 3 800 MHz | 10 MHz |

The requirements in the present document apply to both Wide Area Base Stations and Local Area Base Stations unless otherwise stated.

The present document is intended to cover the provisions of Directive 1999/5/EC [i.2], (R&TTE Directive) article 3.2, which states that "... radio equipment shall be so constructed that it effectively uses the spectrum allocated to terrestrial/space radio communications and orbital resources so as to avoid harmful interference".

In addition to the present document, other ENs that specify technical requirements in respect of essential requirements under other parts of article 3 of the Directive 1999/5/EC [i.2] may apply to equipment within the scope of the present document.

NOTE: A list of such ENs is included on the web site <http://www.newapproach.org>.

2 References

References are either specific (identified by date of publication and/or edition number or version number) or non-specific. For specific references, only the cited version applies. For non-specific references, the latest version of the reference document (including any amendments) applies.

Referenced documents which are not found to be publicly available in the expected location might be found at <http://docbox.etsi.org/Reference>.

NOTE: While any hyperlinks included in this clause were valid at the time of publication, ETSI cannot guarantee their long term validity.

2.1 Normative references

The following referenced documents are necessary for the application of the present document.

- [1] ETSI EN 301 908-1 (V6.2.1) (04-2013): "IMT cellular networks; Harmonized EN covering the essential requirements of article 3.2 of the R&TTE Directive; Part 1: Introduction and common requirements".
- [2] CEPT/ERC/REC 74-01E (Siófok 98, Nice 99, Sesimbra 02, Hradec Kralove 05, Cardiff 11) (01/2011): "Unwanted emissions in the spurious domain".

2.2 Informative references

The following referenced documents are not necessary for the application of the present document but they assist the user with regard to a particular subject area.

- [i.1] Directive 98/34/EC of the European Parliament and of the Council of 22 June 1998 laying down a procedure for the provision of information in the field of technical standards and regulations.
- [i.2] Directive 1999/5/EC of the European Parliament and of the Council of 9 March 1999 on radio equipment and telecommunications terminal equipment and the mutual recognition of their conformity (R&TTE Directive).
- [i.3] ETSI EG 201 399: "Electromagnetic compatibility and Radio spectrum Matters (ERM); A guide to the production of Harmonized Standards for application under the R&TTE Directive".
- [i.4] ETSI TR 102 215 (V1.3.1): "Electromagnetic compatibility and Radio spectrum Matters (ERM); Recommended approach, and possible limits for measurement uncertainty for the measurement of radiated electromagnetic fields above 1 GHz".
- [i.5] ETSI EN 300 019-1-0: "Environmental Engineering (EE); Environmental conditions and environmental tests for telecommunications equipment; Part 1-0: Classification of environmental conditions; Introduction".
- [i.6] ETSI TR 100 028 (all parts) (V1.4.1): "Electromagnetic compatibility and Radio spectrum Matters (ERM); Uncertainties in the measurement of mobile radio equipment characteristics".
- [i.7] Recommendation ITU-R SM.329-12 (2012): "Unwanted emissions in the spurious domain".
- [i.8] Directive 98/48/EC of the European Parliament and of the Council of 20 July 1998 amending Directive 98/34/EC laying down a procedure for the provision of information in the field of technical standards and regulations.

3 Definitions, symbols and abbreviations

3.1 Definitions

For the purposes of the present document, the terms and definitions given in the R&TTE Directive [i.2] and the following apply:

burst: period during which radio waves are intentionally transmitted, preceded and succeeded by periods during which no intentional transmission is made

environmental profile: declared range of environmental conditions under which equipment within the scope of the present document is required to be compliant

integral antenna: antenna which is declared to be part of the radio equipment by the manufacturer

NOTE: Even when equipment with an integral antenna is concerned, it might still be possible to separate the antenna from the equipment using a special tool. In such cases the assessment of the radio equipment and of the antenna against requirements of the present document may be done separately.

maximum output power: mean power level per carrier of the base station measured at the antenna connector in a specified reference condition

mean power: when applied to a modulated signal, this is the power (transmitted or received) in a bandwidth

nominal maximum output power: maximum nominal mean power level per carrier of the user equipment available at the antenna connector declared by the manufacturer; for equipment implementing dynamic change of modulation format, it is intended as the maximum nominal mean power associated to the modulation format delivering the highest power

receiver thermal noise power: equal to $k \times T \times BW \times F$

WiMAX: trade marked name for the OFDMA TDD WMAN IMT technology

3.2 Symbols

For the purposes of the present document, the following symbols apply:

| | |
|--------------|---|
| A_{BS} | Base Station Interface A |
| A_{MS} | Mobile Station Interface A |
| A_{UUT} | Unit Under Test Interface A |
| BW | Nominal channel bandwidth |
| dB | decibel |
| dBc | decibel relative to carrier |
| dBm | decibel relative to 1 milliwatt |
| f | Frequency of measurement |
| f_c | centre frequency of the assigned channel |
| F | Receiver noise figure |
| k | Boltzmann's constant |
| M_{BS} | Base Station Interface M |
| M_{MS} | Mobile Station Interface M |
| N_{th} | Receiver thermal noise power expressed in dBm |
| P_{SENS} | Receiver sensitivity level at BER $\leq 10^{-6}$ (or equivalent PER) performance, corresponding to the most robust modulation and coding rate supported by the technology |
| P_{SENS5} | Receiver sensitivity level at BER 10^{-6} for a 5 MHz channelized system, corresponding to the most robust modulation and coding rate supported by the technology |
| P_{SENS10} | Receiver sensitivity level at BER 10^{-6} for a 10 MHz channelized system, corresponding to the most robust modulation and coding rate supported by the technology |
| P_{nom} | declared nominal maximum output Power |
| T | Ambient temperature in Kelvin |

3.3 Abbreviations

For the purposes of the present document, the following abbreviations apply:

| | |
|-------|---|
| ACLR | Adjacent Channel Leakage power Ratio |
| ACS | Adjacent Channel Selectivity |
| BCI | Band Class Index |
| BER | Bit Error Ratio |
| BS | Base Station |
| CW | Continuous Wave |
| ERM | Electromagnetic compatibility and Radio spectrum Matters |
| GHz | GigaHertz |
| IMT | International Mobile Telecommunications |
| MHz | MegaHertz |
| MSG | Mobile Standards Group |
| OFDMA | Orthogonal Frequency Division Multiple Access |
| PER | Packet Error Ratio |
| R&TTE | Radio equipment and Telecommunications Terminal Equipment |
| RF | Radio Frequency |
| RMS | Root Mean Square |
| RRC | Root Raised Cosine |
| Rx | Receiver |
| TDD | Time Division Duplexing |
| TFES | Task Force for European Standards for IMT |
| TPC | Transmit Power Control |
| Tx | Transmit, Transmitter |
| UE | User Equipment |
| UEE | User Equipment Emulator |

UUT Unit Under Test
 WMAN Wireless Metropolitan Area Network

4 Essential requirements specification

With reference to article 3.2 of Directive 1999/5/EC [i.2] the phenomena in this clause have been identified as relevant to the essential requirements.

4.1 Environmental profile

The technical requirements of the present document apply under the environmental profile for operation of the equipment, which shall be declared by the manufacturer. The equipment shall comply with all the technical requirements of the present document at all times when operating within the boundary limits of the required operational environmental profile.

4.2 Conformance requirements

This clause describes the conformance requirements for OFDMA TDD WMAN Base Stations.

4.2.1 Introduction

To meet the essential requirement under article 3.2 of the R&TTE Directive [i.2] for IMT Base Stations (BS) six essential parameters in addition to those in EN 301 908-1 [1] have been identified. Table 4.2.1-1 provides a cross reference between these six essential parameters and the corresponding nine technical requirements for equipment within the scope of the present document.

To fulfil an essential parameter the compliance with all the corresponding technical requirements in table 4.2.1-1 shall be verified.

Table 4.2.1-1: Cross references

| Essential parameter | Corresponding technical requirements |
|--|--|
| Spectrum emissions mask | 4.2.2 Transmitter Spectrum emissions mask |
| | 4.2.3 Transmitter adjacent channel leakage power ratio |
| | 4.2.6 Transmitter Intermodulation characteristics |
| Conducted spurious emissions in active mode | 4.2.4 Transmitter spurious emissions |
| Accuracy of maximum output power | 4.2.5 Transmitter maximum output power |
| Conducted spurious emission in idle mode | 4.2.7 Receiver spurious emissions |
| Impact of interference on receiver performance | 4.2.8 Receiver Blocking characteristics |
| | 4.2.9 Receiver Intermodulation characteristics |
| Receiver adjacent channel selectivity | 4.2.10 Receiver Adjacent Channel Selectivity (ACS) |

There are EC and ECC Decisions for the harmonisation of certain frequency bands for terrestrial systems capable of providing electronic communications services, including technical conditions and parameters related to spectrum usage of the bands. These are related to the deployment and installation of the equipment, but are not related to the conformity of the equipment with the present document.

4.2.2 Transmitter Spectrum Emission Mask

4.2.2.1 Definition

The Transmitter Spectrum Emission Mask defines an out of band emission requirement for the transmitter. These out of band emissions are unwanted emissions outside the channel bandwidth resulting from the modulation process and non-linearity in the transmitter but excluding spurious emissions.

4.2.2.2 Limits

A base station transmitting on a single RF carrier configured in accordance with the manufacturer's specification shall meet the requirement.

4.2.2.2.1 Spectrum emission mask for 5 MHz channel bandwidth - BCI 1.B and 3.A

Table 4.2.2.2.1-1: Spectrum Emission Mask for 5 MHz channel bandwidth

| Offset from channel centre frequency (Δf) (MHz) | Allowed emission level within the integration bandwidth (dBm) | Integration bandwidth (kHz) |
|---|---|-----------------------------|
| $2,5 \leq \Delta f < 3,5$ | -13 dBm | 50 |
| $3,5 \leq \Delta f < 12,5$ | -13 dBm | 1 000 |

4.2.2.2.2 Spectrum emission mask for 10 MHz channel bandwidth - BCI 1.B and 3.A

Table 4.2.2.2.2-1: Spectrum Emission Mask for 10 MHz channel bandwidth

| Offset from channel centre frequency (Δf) (MHz) | Allowed emission level within the integration bandwidth (dBm) | Integration bandwidth (kHz) |
|---|---|-----------------------------|
| $5 \leq \Delta f < 6$ | -13 dBm | 100 |
| $6 \leq \Delta f < 25$ | -13 dBm | 1 000 |

4.2.2.2.3 Spectrum emission mask for BCI 5L.A, 5L.C, 5H.A and 5H.C

Table 4.2.2.2.3-1: Relative Spectrum Emission Mask

| P_{nom} | Frequency Offset | | | | |
|--|------------------|-----------|-----------|---|----------|
| | 0,5 x BW | 0,71 x BW | 1,06 x BW | 2,0 x BW | 2,5 x BW |
| $39 \text{ dBm} < P_{nom}$ | -20 dB | -27 dB | -32 dB | -50 dB | -50 dB |
| $33 \text{ dBm} < P_{nom} \leq 39 \text{ dBm}$ | -20 dB | -27 dB | -32 dB | $-50 \text{ dB} + (39 \text{ dBm} - P_{nom})$ | Note |

NOTE: See table 4.2.2.2.3-2.

Table 4.2.2.2.3-2: Absolute Spectrum Emission Mask

| P_{nom} | Frequency Offset | | | |
|--|---|--|---|--|
| | $0,5 \times BW < \Delta f < 0,71 \times BW$ | $0,71 \times BW < \Delta f < 1,06 \times BW$ | $1,06 \times BW < \Delta f < 2,0 \times BW$ | $2,0 \times BW < \Delta f < 2,5 \times BW$ |
| $33 \text{ dBm} < P_{nom} \leq 39 \text{ dBm}$ | Note 1 | Note 1 | Note 1 | $-21 + y \text{ dBm/MHz}$ |
| $P_{nom} \leq 33 \text{ dBm}$ | -5,5 dBm/MHz | -5,5 dBm/MHz | -23,5 dBm/MHz | -23,5 dBm/MHz |

NOTE 1: See table 4.2.2.2.3-1.
NOTE 2: $y = -10 \log (BW/10)$.

4.2.2.3 Conformance

Conformance tests described in clause 5.4.1 shall be carried out.

4.2.3 Transmitter Adjacent Channel Leakage power Ratio (ACLR)

4.2.3.1 Definition

Adjacent Channel Leakage power Ratio (ACLR) is the ratio of the mean power measured through a filter pass band centred on the assigned channel frequency to the mean power measured through the same filter pass band centred on a first or second adjacent channel. The first adjacent and second adjacent channel centre offsets relative to the assigned channel centre frequency are 5 MHz and 10 MHz when the nominal occupied channel bandwidth is 5 MHz. These offsets are 10 MHz and 20 MHz respectively when the nominal occupied channel bandwidth is 10 MHz.

4.2.3.2 Limits

The requirements in tables 4.2.3.2.1-1, 4.2.3.2.1-2, 4.2.3.2.2-1 and 4.2.3.2.2-2 are based upon a measurement filter characteristic that is rectangular with a width dependent upon the BS channel bandwidth and the BCI.

The requirements in tables 4.2.3.2.1-3 and 4.2.3.2.2-3 are based upon an adjacent channel measurement filter characteristic that is RRC with a roll off factor of 0,22 and a width dependent upon the UE channel bandwidth.

The measurement bandwidth for the on-channel power is:

- 4,75 MHz for a 5 MHz channelized system;
- 9,5 MHz for a 10 MHz channelized system.

4.2.3.2.1 ACLR requirements for 5 MHz channel bandwidth

Table 4.2.3.2.1-1: ACLR requirement for 5 MHz channel bandwidth and BCI 1.B, 5L.A and 5H.A

| Adjacent channel centre frequency | Minimum required ACLR relative to assigned channel frequency (dB) | Adjacent channel Measurement filter width (MHz) |
|--|---|---|
| Base station channel centre frequency ± 5 MHz | 44,2 | 4,75 |
| Base station channel centre frequency ± 10 MHz | 49,2 | 4,75 |

Table 4.2.3.2.1-2: ACLR requirement for 5 MHz channel bandwidth and BCI 3A

| Adjacent channel centre frequency | Minimum required ACLR relative to assigned channel frequency (dB) | Adjacent channel Measurement filter width (MHz) |
|--|---|---|
| Base station channel centre frequency ± 5 MHz | 44,2 | 4,75 |
| Base station channel centre frequency ± 10 MHz | 54,2 | 4,75 |

Table 4.2.3.2.1-3: Additional ACLR requirement for 5 MHz channel bandwidth and BCI 3A

| Adjacent channel centre frequency | Minimum required ACLR relative to assigned channel frequency (dB) | Adjacent channel Measurement filter width (MHz) |
|--|---|---|
| Base station channel centre frequency ± 5 MHz | 52,7 | 3,84 |
| Base station channel centre frequency ± 10 MHz | 65,2 | 3,84 |

4.2.3.2.2 ACLR requirements for 10 MHz channel bandwidth

Table 4.2.3.2.2-1: ACLR requirement for 10 MHz channel bandwidth and BCI 1.B, 5L.A and 5H.A

| Adjacent channel centre frequency | Minimum required ACLR relative to assigned channel frequency (dB) | Adjacent channel Measurement filter width (MHz) |
|--|---|---|
| Base station channel centre frequency ± 10 MHz | 44,2 | 9,5 |
| Base station channel centre frequency ± 20 MHz | 49,2 | 9,5 |

Table 4.2.3.2.2-2: ACLR requirement for 10 MHz channel bandwidth and BCI 3A

| Adjacent channel centre frequency | Minimum required ACLR relative to assigned channel frequency (dB) | Adjacent channel Measurement filter width (MHz) |
|--|---|---|
| Base station channel centre frequency ± 5 MHz | 44,2 | 9,5 |
| Base station channel centre frequency ± 10 MHz | 54,2 | 9,5 |

Table 4.2.3.2.2-3: Additional ACLR requirement for 10 MHz channel bandwidth and BCI 3A

| Adjacent channel centre frequency | Minimum required ACLR relative to assigned channel frequency (dB) | Adjacent channel Measurement filter width (MHz) |
|--|---|---|
| Base station channel centre frequency ± 5 MHz | 52,7 | 7,68 |
| Base station channel centre frequency ± 10 MHz | 65,2 | 7,68 |

4.2.3.3 Conformance

Conformance tests described in clause 5.4.2 shall be carried out.

4.2.4 Transmitter spurious emissions

4.2.4.1 Definition

Transmitter spurious emissions are emissions which are caused by unwanted transmitter effects such as harmonics emission, parasitic emission, intermodulation products and frequency conversion products, but exclude out of band emissions. This is measured at the Base Station RF output port.

The spurious emission limits are specified in terms of general requirements in line with Recommendation ITU-R SM.329-12 [i.7] and frequency range specific requirements to address inter-system co-existence.

4.2.4.2 Limits

4.2.4.2.1 General requirements

The requirements shall apply to both Wide Area BS and Local Area BS.

The limits of spurious emissions (or more precisely, according latest ITU-R definitions, unwanted emissions in the spurious domain), shall conform to CEPT/ERC/REC 74-01 [2].

The following requirements in tables 4.2.4.2.1.1-1 and 4.2.4.2.1.2-1 are only applicable for frequencies, which are greater than 250 % of the channel bandwidth (that is 12,5 MHz for the 5 MHz channel bandwidth and 25 MHz for the 10 MHz channel bandwidth) away from the centre carrier frequency.

In the following f_c is the center frequency of transmit signal and f is the frequency of spurious emission.

4.2.4.2.1.1 Requirements for 5 MHz channel bandwidth

Table 4.2.4.2.1.1-1: Spurious Emission requirement for 5 MHz channel bandwidth

| Segment | Frequency Range | Measurement Bandwidth | Maximum allowed level (dBm) |
|---------|---|---|-----------------------------|
| 1 | $9 \text{ kHz} \leq f < 150 \text{ kHz}$ | 1 kHz | -36 |
| 2 | $150 \text{ kHz} \leq f < 30 \text{ MHz}$ | 10 kHz | -36 |
| 3 | $30 \text{ MHz} \leq f < 1\,000 \text{ MHz}$ | 100 kHz | -36 |
| 4 | $1 \text{ GHz} \leq f < f_{\text{MAX}} \text{ GHz}$ | 30 kHz If $12,5 \leq f_c - f < 50 \text{ MHz}$ 300 kHz If $50 \leq f_c - f < 60 \text{ MHz}$ 1 MHz If $60 \leq f_c - f \text{ MHz}$ | -30 |

NOTE: The maximum Segment 4 measurement frequency f_{MAX} , is 12,75 GHz for BCI 1.B 13,45 GHz for BCI 3.A and 19 GHz for BCI 5L.A, 5L.C, 5H.A 5H.C.

4.2.4.2.1.2 Requirements for 10 MHz channel bandwidth

Table 4.2.4.2.1.2-1: Spurious Emission requirement for 10 MHz channel bandwidth

| Segment | Frequency Range | Measurement Bandwidth | Maximum allowed level (dBm) |
|---------|---|---|-----------------------------|
| 1 | $9 \text{ kHz} \leq f < 150 \text{ kHz}$ | 1 kHz | -36 |
| 2 | $150 \text{ kHz} \leq f < 30 \text{ MHz}$ | 10 kHz | -36 |
| 3 | $30 \text{ MHz} \leq f < 1\,000 \text{ MHz}$ | 100 kHz | -36 |
| 4 | $1 \text{ GHz} \leq f < f_{\text{MAX}} \text{ GHz}$ | 30 kHz If $25 \leq f_c - f < 100 \text{ MHz}$ 300 kHz If $100 \leq f_c - f < 120 \text{ MHz}$ 1 MHz If $120 \leq f_c - f \text{ MHz}$ | -30 |

NOTE: The maximum Segment 4 measurement frequency f_{MAX} , is 12,75 GHz for BCI 1.B 13,45 GHz for BCI 3.A and 19 GHz for BCI 5L.A, 5L.C 5H.A 5H.C.

4.2.4.2.2 Additional Spurious Emission Requirements

Table 4.2.4.2.2-1: Additional spurious emissions requirements for BS (Out of Band)

| Band (MHz) | Maximum level (dBm) | Measurement bandwidth (MHz) | Applicable BCI |
|--------------------------|---------------------|-----------------------------|----------------|
| $791 \leq f < 821$ | -52 | 1 | All BCI |
| $832 \leq f < 862$ | -49 | 1 | |
| $876 \leq f < 915$ | -51 | 1 | |
| $921 \leq f < 925$ | -47 | 1 | |
| $925 \leq f < 960$ | -52 | 1 | |
| $1\,710 \leq f < 1\,785$ | -51 | 1 | |
| $1\,805 \leq f < 1\,880$ | -52 | 1 | |
| $1\,920 \leq f < 1\,980$ | -49 | 1 | |
| $2\,110 \leq f < 2\,170$ | -52 | 1 | |
| $1\,900 \leq f < 1\,920$ | -52 | 1 | |
| $2\,010 \leq f < 2\,025$ | -52 | 1 | |
| $2\,500 \leq f < 2\,570$ | -49 | 1 | |
| $2\,570 \leq f < 2\,620$ | -52 | 1 | |
| $2\,620 \leq f < 2\,690$ | -52 | 1 | |

4.2.4.3 Conformance

Conformance tests described in clause 5.4.3 shall be carried out.

4.2.5 Base station maximum output power

4.2.5.1 Definition

The maximum output power tolerance is the difference between the declared P_{nom} and the actual maximum output power and corresponding tolerance limits.

4.2.5.2 Limits

The requirement shall apply to both Wide Area BS and Local Area BS.

In normal conditions, the measured output power, derived according to clause 5.4.4.1.2, shall remain within +2,7 dB and -2,7 dB of the manufacturer's rated output power.

In extreme conditions, the measured output power, derived according to clause 5.4.4.1.2, shall remain within +3,2 dB and -3,2 dB of the manufacturer's rated output power.

4.2.5.3 Conformance

Conformance tests described in clause 5.4.4 shall be carried out.

4.2.6 Transmit intermodulation

4.2.6.1 Definition

The transmit intermodulation performance is a measure of the capability of the transmitter to inhibit the generation of signals in its non linear elements caused by presence of the wanted signal and an interfering signal reaching the transmitter via the antenna.

The transmit intermodulation level is the power of the intermodulation products when a modulated interference signal is injected into the antenna connector at a mean power level of 30 dB lower than that of the mean power of the wanted signal. The wanted signal bandwidth shall be 5 MHz and 10 MHz respectively. The interferer has the same bandwidth as the wanted signal.

For 5 MHz channel BW, the centre frequency of the interference signal offset from the subject signal carrier centre frequency shall be at ± 5 MHz, ± 10 MHz, ± 15 MHz (± 10 MHz, ± 20 MHz, ± 30 MHz for 10 MHz channel BW) but exclude interference frequencies that are partially or completely outside of the declared operating frequency band of the base station.

4.2.6.2 Limits

With the test signal applied, the spectrum emission mask, ACLR and spurious emission requirements at the specific 3rd and 5th order intermodulation frequencies, excluding those overlapping the interfering signal, shall continue to meet the limits in clauses 4.2.2, 4.2.3 and 4.2.4.

4.2.6.3 Conformance

Conformance tests described in clause 5.4.5 shall be carried out.

4.2.7 Receiver spurious emissions

4.2.7.1 Definition

The spurious emissions power is the power of emissions, generated or amplified in a receiver, which appear at the BS antenna connector. The requirements apply to all BS with separate Rx and Tx antenna port. The test shall be performed when both Tx and Rx are on with the Tx port terminated.

For BS equipped with only a single antenna connector for both transmitter and receiver, the requirements of clause 4.2.4 Transmitter spurious emissions shall apply to this port, and this test need not be performed.

The following requirements in table 4.2.7.2-1 are only applicable for frequencies, which are greater than 250 % of the channel bandwidth (that is 12,5 MHz for the 5 MHz channel bandwidth and 25 MHz for the 10 MHz channel bandwidth) away from the centre carrier frequency.

4.2.7.2 Limits

The requirement shall apply to both Wide Area BS and Local Area BS.

Table 4.2.7.2-1: General receiver spurious emission requirements

| Frequency band | Measurement bandwidth | Maximum level |
|---|-----------------------|---------------|
| $30 \text{ MHz} \leq f < 1 \text{ GHz}$ | 100 kHz | -57 dBm |
| $1 \text{ GHz} \leq f \leq f_{\text{MAX}} \text{ GHz}$ | 1 MHz | -47 dBm |
| NOTE: The maximum measurement frequency f_{MAX} , is 12,75 GHz for BCI 1.B, 13,45 GHz for BCI 3.A and 19 GHz for BCI 5L.A, 5L.C, 5H.A, 5H.C. | | |

4.2.7.3 Conformance

Conformance tests described in clause 5.4.6 shall be carried out.

4.2.8 Receiver blocking characteristics

4.2.8.1 Definition

The blocking characteristics are a measure of the receiver ability to receive a wanted signal at its assigned channel frequency in the presence of an unwanted interferer on frequencies other than those of the adjacent channels.

4.2.8.2 Limits

P_{SENS5} and P_{SENS10} are the sensitivity levels at $\text{BER} \leq 10^{-6}$, for 5 MHz and 10 MHz channels respectively, corresponding to the most robust modulation and coding rate supported by the base station. The wanted signal with the most robust modulation and coding supported by the base station shall be used.

BER performance requirement at $\text{BER} \leq 10^{-6}$ (or equivalent PER) shall be met when the following signals are coupled to BS antenna input. The blocking performance requirement applies to interfering signals with centre frequency within the ranges specified in tables 4.2.8.2-1 and 4.2.8.2-2 relevant to the nominal channel bandwidth and the specific BCI, using a 1 MHz step size.

Table 4.2.8.2-1: Blocking for 5 MHz channel bandwidth

| BCI | Case | Centre frequency of interfering signal | Interfering signal mean power | Wanted signal mean power | Minimum offset of interfering signal from the channel edge | Type of interfering signal |
|------|------|--|-------------------------------|-----------------------------------|--|---|
| 1.B | 1 | 2 302,5 MHz to 2 397,5 MHz | -40 dBm | $P_{\text{SENS5}} + 6 \text{ dB}$ | 12,5 MHz | Modulation and coding equal to those of the wanted signal |
| 3.A | | 2 502,5 MHz to 2 687,5 MHz | | | | |
| 5L.A | | 3 402,5 MHz to 3 597,5 MHz | | | | |
| 5H.A | | 3 602,5 MHz to 3 797,5 MHz | | | | |
| 1.B | 2 | 2 282,5 MHz to 2 297,5 MHz 2 402,5 MHz to 2 417,5 MHz | -40 dBm | $P_{\text{SENS5}} + 6 \text{ dB}$ | 12,5 MHz | Modulation and coding equal to those of the wanted signal |
| 3.A | | 2 482,5 MHz to 2 497,5 MHz 2 692,5 MHz to 2 707,5 MHz | | | | |
| 5L.A | | 3 382,5 MHz to 3 397,5 MHz 3 602,5 MHz to 3 617,5 MHz | | | | |
| 5H.A | | 3 582,5 MHz to 3 597,5 MHz 3 802,5 MHz to 3 817,5 MHz | | | | |
| 1.B | 3 | 1 MHz to 2 280 MHz, 2 420 MHz to 12 750 MHz | -15 dBm | $P_{\text{SENS5}} + 6 \text{ dB}$ | – | CW carrier |
| 3.A | | 1 MHz to 2 480 MHz, 2 710 MHz to 12 750 MHz | | | | |
| 5L.A | | 1 MHz to 3 380 MHz, 3 620 MHz to 12 750 MHz | | | | |
| 5H.A | | 1 MHz to 3 580 MHz, 3 820 MHz to 12 750 MHz | | | | |

Table 4.2.8.2-2: Blocking for 10 MHz channel bandwidth

| BCI | Case | Centre frequency of interfering signal | Interfering signal mean power | Wanted signal mean power | Minimum offset of interfering signal from the channel edge | Type of interfering signal |
|------|------------------------|--|-------------------------------|------------------------------------|--|---|
| 1.B | 1 | 2 305 MHz to 2 395 MHz | -40 dBm | $P_{\text{SENS10}} + 6 \text{ dB}$ | 25 MHz | Modulation and coding equal to those of the wanted signal |
| 3.A | | 2 505 MHz to 2 685 MHz | | | | |
| 5L.A | | 3 405 MHz to 3 595 MHz | | | | |
| 5H.A | | 3 605 MHz to 3 795 MHz | | | | |
| 1.B | 2 | 2 285 MHz to 2 295 MHz | -40 dBm | $P_{\text{SENS10}} + 6 \text{ dB}$ | 25 MHz | Modulation and coding equal to those of the wanted signal |
| | | 2 405 MHz to 2 415 MHz | | | | |
| 3.A | | 2 485 MHz to 2 495 MHz | | | | |
| | | 2 695 MHz to 2 705 MHz | | | | |
| 5L.A | | 3 385 MHz to 3 395 MHz | | | | |
| | 3 605 MHz to 3 615 MHz | | | | | |
| 5H.A | | 3 585 MHz to 3 595 MHz | | | | |
| | | 3 805 MHz to 3 815 MHz | | | | |
| 1.B | 3 | 1 MHz to 2 280 MHz, | -15 dBm | $P_{\text{SENS10}} + 6 \text{ dB}$ | - | CW carrier |
| | | 2 420 MHz to 12 750 MHz | | | | |
| 3.A | | 1 MHz to 2 480 MHz, | | | | |
| | | 2 710 MHz to 12 750 MHz | | | | |
| 5L.A | | 1 MHz to 3 380 MHz, | | | | |
| | | 3 620 MHz to 12 750 MHz | | | | |
| 5H.A | | 1 MHz to 3 580 MHz, | | | | |
| | | 3 820 MHz to 12 750 MHz | | | | |

4.2.8.3 Conformance

Conformance tests described in clause 5.4.7 shall be carried out.

4.2.9 Receiver intermodulation characteristics

4.2.9.1 Definition

Third and higher order mixing of two interfering RF signals can produce an interfering signal in the band of the desired channel. Intermodulation response rejection is a measure of the capability of the receiver to receive a wanted signal on its assigned channel frequency in the presence of two or more interfering signals which have a specific frequency relationship to the wanted signal.

4.2.9.2 Limits

P_{SENS5} and P_{SENS10} are the sensitivity levels at $\text{BER} \leq 10^{-6}$, for 5 MHz and 10 MHz channels respectively, corresponding to the most robust modulation and coding rate supported by the base station.

BER performance requirement at $\text{BER} \leq 10^{-6}$ (or equivalent PER) shall be met when the following signals are coupled to BS antenna input:

- A wanted signal at the assigned channel frequency, with mean power 6 dB above P_{SENS5} .
- Two interfering signals with the following parameters.

Table 4.2.9.2-1: Receiver intermodulation characteristics for 5 MHz channel bandwidth

| Interfering signal mean power | Offset of interfering signal centre frequency from the channel edge | Type of interfering signal |
|-------------------------------|---|---|
| -48 dBm | 7,5 MHz | CW signal |
| -48 dBm | 17,5 MHz | Modulation and coding equal to those of the wanted signal |

BER performance requirement at $BER \leq 10^{-6}$ (or equivalent PER) shall be met when the following signals are coupled to BS antenna input:

- A wanted signal at the assigned channel frequency, with mean power 6 dB above P_{SENS10} .
- Two interfering signals with the following parameters.

Table 4.2.9.2-2: Receiver intermodulation characteristics for 10 MHz channel bandwidth

| Interfering signal mean power | Offset of interfering signal centre frequency from the channel edge | Type of interfering signal |
|-------------------------------|---|---|
| -48 dBm | 15 MHz | CW signal |
| -48 dBm | 35 MHz | Modulation and coding equal to those of the wanted signal |

4.2.9.3 Conformance

Conformance tests described in clause 5.4.8 shall be carried out.

4.2.10 Receiver Adjacent Channel Selectivity

4.2.10.1 Definition

Adjacent Channel Selectivity (ACS) is a measure of a receiver's ability to receive a wanted signal at its assigned channel frequency in the presence of an adjacent channel signal at a given frequency offset from the centre frequency of the assigned channel. ACS is the interferer power level (in dBm) relative to thermal noise (N_{th}).

4.2.10.2 Limits

Table 4.2.10.2-1 specifies the limits and the test parameters for the receiver ACS in the first adjacent channel and 2nd adjacent channels for 5 MHz and 10 MHz channel bandwidths. For an assigned nominal channel bandwidth BW, the interferer channel bandwidth is the same. The wanted and interferer power levels are evaluated over 95 % of the BW centred on the wanted or adjacent channel as identified in table 4.2.10.2-1. The compliant system shall be able to meet a Bit Error Ratio (BER) $< 10^{-6}$ (or equivalent PER) with the interference level in either the first adjacent or second adjacent channel applied as specified in the table. Alternatively depending on packet sizes supported, equivalent Packet Error Ratio (PER) criteria can be used.

Table 4.2.10.2-1: Limits and test parameters for receiver adjacent channel selectivity

| Description | In-channel | Interferer on 1 st adjacent channel | Interferer on 2 nd adjacent channel |
|------------------------|----------------|--|--|
| ACS limits (dB) | | 40 | 50 |
| Power (dBm) | $P_{SENS} + 3$ | $N_{th} + 40$ | $N_{th} + 50$ |
| Centre frequency (MHz) | f_c | $f_c \pm BW$ | $f_c \pm 2 \times BW$ |

NOTE: N_{th} is the receiver thermal noise power of the equipment (in dBm) as declared by the manufacturer.

4.2.10.3 Conformance

Conformance tests described in clause 5.4.9 shall be carried out.

5 Testing for compliance with technical requirements

5.1 Environmental conditions for testing

The technical requirements of the present document apply under the environmental profile, for intended operation of the equipment and antennas, declared by the manufacturer.

The environmental profile may be determined by the environmental class of the equipment according to the guidance given in EN 300 019-1-0 [i.5].

The combination of the equipment and its antennas shall comply with all the requirements of the present document at all times when operating within the boundary limits of the declared operational environmental profile.

5.2 Product information

The following information shall be stated by the manufacturer in order to carry out the test suites:

- the operating RF channel centre frequency range of the equipment;
- BCI;
- the nominal occupied channel bandwidth(s), BW;
- the modulation format(s) employed by the equipment;
- the nominal maximum output power (P_{nom}) from the equipment and power class;
- the operational environmental profile(s) applicable to the equipment;
- the TPC range(s);
- the receiver sensitivity levels P_{SENS5} and P_{SENS10} and the equipment receiver thermal noise power N_{th} (in dBm).

5.3 Interpretation of the measurement results

The interpretation of the results recorded in a test report for the measurements described in the present document shall be as follows:

- the measured value related to the corresponding limit shall be used to decide whether the user equipment meets the requirements of the present document;
- the value of the measurement uncertainty for the measurement of each parameter shall be documented in the test report;
- the recorded value of the measurement uncertainty shall be, for each measurement, equal to or lower than the figures in table 5.3-1.

For the test methods, according to the present document, the measurement uncertainty figures shall be calculated and shall correspond to an expansion factor (coverage factor) $k = 1,96$ (which provides a confidence level of 95 % in the case where the distributions characterizing the actual measurement uncertainties are normal (Gaussian)). Principles for the calculation of measurement uncertainty are contained in TR 100 028 [i.6] or TR 102 215 [i.4].

Table 5.3-1 is based on such expansion factors.

Table 5.3-1: Maximum measurement uncertainty of the test system

| Parameter | Condition | Uncertainty |
|--|--|-------------|
| Transmitter Spectrum Emission Mask | | ±1,5 dB |
| Adjacent Channel Leakage power Ratio (ACLR) | | ±0,8 dB |
| Transmitter spurious emissions | 9 kHz < f ≤ 4 GHz | ±2,0 dB |
| | 4 GHz < f ≤ 12,75 GHz | ±4,0 dB |
| Base Station maximum output power | | ±0,7 dB |
| Transmitter intermodulation | For Operating band unwanted emissions | ±2,5 dB |
| | For ACLR | ±2,2 dB |
| | For "Spurious emissions": | |
| | f ≤ 2,2 GHz | ±2,5 dB |
| | 2,2 GHz < f ≤ 4 GHz | ±2,8 dB |
| f > 4 GHz | ±4,5 dB | |
| For co-existence requirements | ±2,8 dB | |
| Interference signal | ±1,0 dB | |
| Receiver spurious emissions | 30 MHz ≤ f ≤ 4 GHz | ±2,0 dB |
| | 4 GHz < f ≤ 12,75 GHz | ±4,0 dB |
| Blocking characteristics | In-band blocking, using modulated interferer | ±1,6 dB |
| | Out of band blocking, using CW interferer: | |
| | 1 MHz < f _{interferer} ≤ 3 GHz | ±1,3 dB |
| | 3 GHz < f _{interferer} ≤ 12,75 GHz | ±3,2 dB |
| Receiver intermodulation characteristics | | ±1,8 dB |
| Adjacent Channel Selectivity (ACS) | | ±1,4 dB |
| NOTE 1: For RF tests, it should be noted that the uncertainties in table 5.3-1 apply to the test system operating into a nominal 50 Ω load and do not include system effects due to mismatch between the EUT and the Test System. | | |
| NOTE 2: Annex G of TR 100 028-2 [i.6] provides guidance for the calculation of the uncertainty components relating to mismatch. | | |
| NOTE 3: If the test system for a test is known to have a measurement uncertainty greater than that specified in table 5.3-1, this equipment can still be used, provided that an adjustment is made follows: any additional uncertainty in the test system over and above that specified in table 5.3-1 is used to tighten the test requirements - making the test harder to pass (for some tests, e.g. receiver tests, this may require modification of stimulus signals). This procedure will ensure that a test system not compliant with table 5.3-1 does not increase the probability of passing an EUT that would otherwise have failed a test if a test system compliant with table 5.3-1 had been used. | | |

5.4 Essential radio test suites

All tests are carried out under normal environmental conditions unless otherwise specified.

5.4.1 Transmitter Spectrum Emission Mask

The purpose of this test is to verify compliance of BS equipment to the transmitter spectrum emission mask requirements of clause 4.2.2.

5.4.1.1 Method of measurement

Figure 5.4.1.1-1 shows the test setup for testing the BS transmitter spectrum emission mask.

In the case that BS supports multiple transmit antenna (antenna 1 to N):

- 1) If single transmit antenna is a valid mode of operation, Steps 1 to 7 below shall be performed on a selected single antenna port with P_{nom} transmit level.
- 2) To test the mode with multiple antennas enabled:
 - a) Steps 1 to 7 shall be repeated when all antenna are enabled with a total transmit power of P_{nom} (e.g. each antenna is transmitting at P_{nom} - 10 × log₁₀ N level).
 - b) The measurement results of Step 4 are combined (measured power levels are added).

- c) The combined measurement power is compared with the requirements.

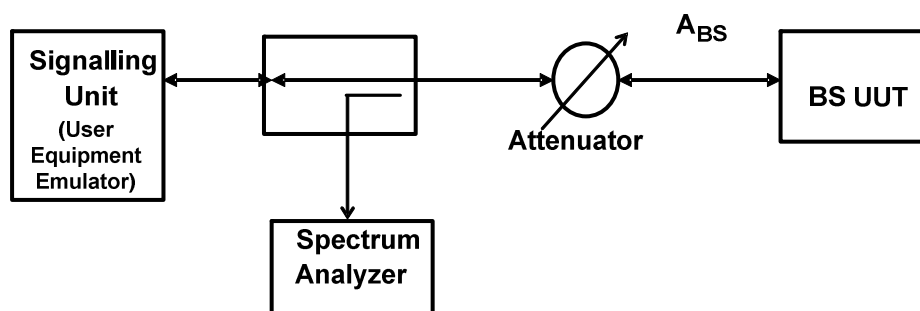

Figure 5.4.1.1-1: Test Setup for BS transmitter spectrum emission mask measurement

5.4.1.1.1 Initial conditions

The UUT shall be configured to operate at the Pnom level declared for the equipment.

Spectrum Emission mask shall be measured during the transmitting part of the TDD frame only. The equipment shall be configured to operate with continuous modulation mode switching at the maximum switching speed permitted by the system, with equal duty cycle for all modulation orders, and with all training bursts or reference signals active as in normal operation.

In spectrum analyzer, set the resolution bandwidth according to appropriate table in clause 4.2.2.2 and also set the video bandwidth to value of three times the resolution bandwidth. True RMS detector shall be used.

5.4.1.1.2 Procedure

- Step 1 Set the RF channel to the lowest RF channel centre frequency from the declared range.
- Step 2 Ensure the data link connection has been established between BS UUT and Signalling Unit.
- Step 3 The BS UUT is configured to continuously transmit at Pnom as measured over the 5 MHz or 10 MHz of allocated bandwidth.
- Step 4 Measure and note the signal spectrum over the range specified in the appropriate table in clause 4.2.2.2 according to the specified measurement bandwidths. Note that measurement aggregation maybe needed to compare with the specified numbers according to the 1 MHz measurement bandwidth in the tables.
- Step 5 Repeat Steps 2 to 4 at the middle and highest RF channel centre frequencies from the declared range.
- Step 6 Repeat Steps 1 to 5 for all modulation schemes supported by the equipment under test.
- Step 7 End of test.

5.4.1.2 Test requirements

For the BS UUT the signal spectrum recorded in the steps above for each of the RF channel centre frequencies and supported modulation schemes shall meet the requirements of clause 4.2.2.2 for the appropriate channel bandwidths and BCI supported.

5.4.2 Transmitter Adjacent Channel Leakage Power Ratio (ACLR)

The purpose of this test is to verify compliance of BS equipment to the transmitter adjacent channel leakage power ratio requirements of clause 4.2.3.

5.4.2.1 Method of measurement

Figure 5.4.2.1-1 shows the test setup for testing the BS transmitter adjacent channel leakage ratio.

In the case that BS supports multiple transmit antenna (antenna 1 to N):

- 1) If single transmit antenna is a valid mode of operation, Steps 1 to 11 below shall be performed on a selected single antenna port with P_{nom} transmit level.
- 2) To test the mode with multiple antennas enabled:
 - a) Steps 1 to 11 shall be repeated when all antenna are enabled with a total transmit power of P_{nom} (e.g. each antenna is transmitting at $P_{nom} - 10 \times \log_{10} N$ level).
 - b) The measurement results of Steps 5 and 7 are combined (measured power levels are added).
 - c) The combined measurement power is compared with the requirements.

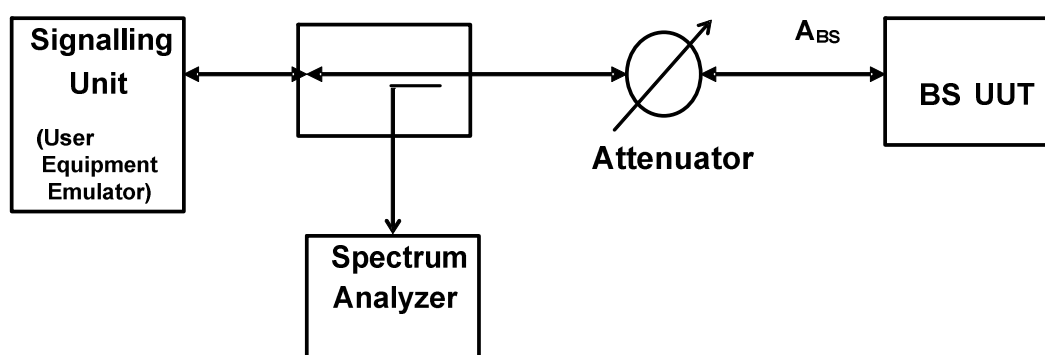

Figure 5.4.2.1-1: Test Setup for BS transmitter adjacent channel leakage ratio measurement

5.4.2.1.1 Initial conditions

The UUT shall be configured to operate at the P_{nom} level declared for the equipment.

For systems implementing dynamic change of the modulation order; this test shall be modified and executed accordingly to accurately capture transient behaviour. For example, if a system automatically operates at higher output power when lower order modulations are used, the test shall correctly capture this effect. There may be a need for manufacturers to include information to identify the correct test conditions. The equipment shall be configured to operate with continuous modulation mode switching at the maximum switching speed permitted by the system, with equal duty cycle for all modulation orders, and with all training bursts or reference signals active as in normal operation.

5.4.2.1.2 Procedure

- Step 1 Set the RF channel to the lowest channel centre frequency from the declared range.
- Step 2 Ensure the data link connection has been established between BS UUT and Signalling Unit.
- Step 3 The spectrum analyzer shall be correctly configured to measure the aggregated power. To avoid having the spectrum analyzer average the spectrum during periods when there is no transmission occurring, it is important to use a gated trigger mode. The gated trigger should be set up so that the spectrum analyzer is only triggered when the UUT is transmitting. Some spectrum analyzers can be configured for a gated trigger using the RF burst directly. However, other spectrum analyzers will require an independent gate signal, and this signal shall be derived from the User Equipment Emulator (UEE). It is therefore recommended that the UEE provides a frame trigger signal.

Measurements should only be conducted during the transmission.

- Step 4 Measure the aggregated power measured over a frequency range equal to 4,75 MHz and 9,5 MHz (for 5 MHz and 10 MHz cases respectively) centred on the assigned channel frequency.

- Step 5 Average over a sufficient number of transmitted bursts to obtain a stable reading.
- Step 6 Measure the aggregated power over a frequency range equal to 4,75 MHz and 9,5 MHz (for 5 MHz and 10 MHz cases respectively) centred on the first lower adjacent channel frequency which is 5 MHz (10 MHz for 10 MHz channel bandwidth) apart from operating RF channel center frequency.
- Step 7 Average over a sufficient number of transmitted bursts to obtain a stable reading.
- Step 8 Calculate the ACLR by: (Power according to Step 5)/(Power according to Step 7).
- Step 9 Repeat Steps 4 to 8 for the second adjacent (lower) RF channel (centre frequency 10 MHz for the 5 MHz channel bandwidth and 20 MHz for 10 MHz channel bandwidth, respectively, below the assigned channel frequency of the transmitted signal) and also for the first and second upper adjacent RF channel.
- Step 10 Run Steps 2 to 9 at the middle and highest RF channel center frequencies from the declared range.
- Step 11 End of test.

5.4.2.2 Test requirements

For the BS UUT the maximum power levels recorded in the steps above and the ACLR calculation for each of the RF channel centre frequencies shall meet the requirements of clause 4.2.3.2 for each BCI supported.

5.4.3 Transmitter spurious emissions

The purpose of this test is to verify compliance of BS equipment to the transmitter spurious emission requirements of clause 4.2.4.

5.4.3.1 Method of measurement

Figure 5.4.3.1-1 shows the test setup for testing the BS transmitter spurious emission requirement.

In the case that BS supports multiple transmit antenna (antenna 1 to N):

- 1) If single transmit antenna is a valid mode of operation, Steps 1 to 6 below shall be performed on a selected single antenna port.
- 2) To test the mode with multiple antennas enabled:
 - a) Steps 1 to 6 below shall be repeated when all antenna are enabled (e.g. each antenna is transmitting at $P_{nom} - 10\log_{10}(N)$ level).
 - b) Step 4 is modified to include total combined power (measured power levels are added over N antenna).

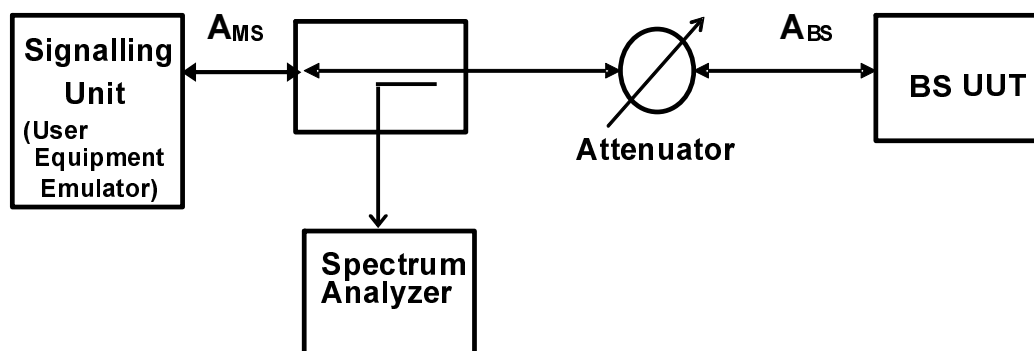

Figure 5.4.3.1-1: Test Setup for BS transmitter spurious emission measurement

5.4.3.1.1 Initial conditions

The UUT shall be configured to operate at the Pnom level declared for the equipment.

In the spectrum analyzer, set the measurement bandwidth as specified in the relevant table of clause 4.2.4. Set the video bandwidth to a value of three times the measurement bandwidth. True RMS detector shall be used.

For systems implementing dynamic change of the modulation order, the equipment shall be configured to operate with continuous modulation mode switching at the maximum switching speed permitted by the system, with equal duty cycle for all modulation orders, and with all training bursts or reference signals active as in normal operation.

5.4.3.1.2 Procedure

- Step 1 Set the RF channel at lowest channel centre frequency from the declared range.
- Step 2 Ensure the data link connection has been established between BS UUT and Signalling Unit.
- Step 3 The BS UUT is configured to transmit at its Pnom output power.
- Step 4 Measure and note the BS transmitter spurious emissions over the frequency range and within the specified measurement bandwidth specified in the relevant table of clause 4.2.4.
- Step 5 Repeat Steps 2 to 4 at the middle and highest RF channel centre frequencies from the declared range.
- Step 6 End of test.

5.4.3.2 Test requirements

For the BS UUT the transmitter spurious emission levels recorded in the steps above for each of the RF channel centre frequencies shall meet the requirements of clause 4.2.4.2 for each BCI supported.

5.4.4 Base Station maximum output power

The purpose of this test is to verify compliance of the BS equipment maximum output power accuracy in support of requirement of clause 4.2.5.

5.4.4.1 Method of measurement

Figure 5.4.4.1-1 shows the test setup for testing the BS transmitter spurious emission requirement.

In the case that BS supports multiple transmit antenna (antenna 1 to N):

- 1) If single transmit antenna is a valid mode of operation, Steps 1 to 6 below shall be performed on a selected single antenna port.
- 2) To test the mode with multiple antennas enabled:
 - a) Steps 1 to 6 below shall be repeated when all antenna are enabled (e.g. each antenna is transmitting at $P_{nom} - 10\log_{10}(N)$ level).

Step 4 is modified to include total combined power (measured power levels are added over N antenna).

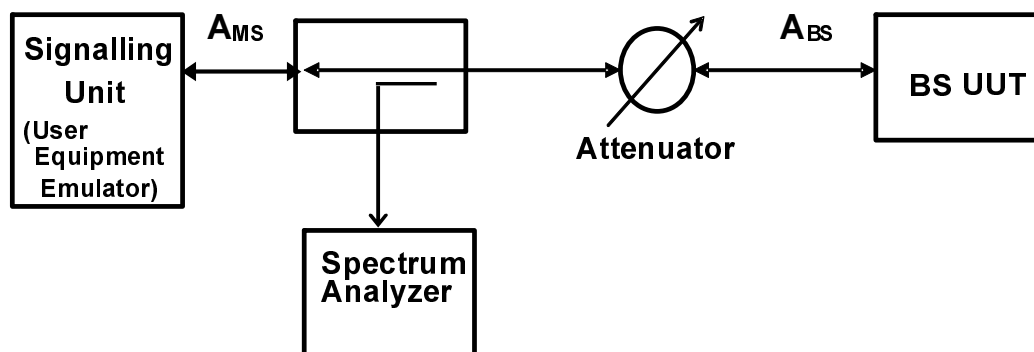

Figure 5.4.4.1-1: Test Setup for BS transmitter maximum output power measurement

5.4.4.1.1 Initial conditions

The UUT shall be configured to operate at its declared maximum output power (P_{nom}) under normal environmental conditions.

5.4.4.1.2 Procedure

- Step 1 Set the RF channel to the lowest channel centre frequency from the declared range. Output power shall be measured during the transmitting part of the TDD frame only.
- Step 2 Make sure the data link connection has been established between BS UUT and Signalling Unit.
- Step 3 The BS UUT is configured to continuously transmit at its declared maximum output power (P_{nom}) as measured over the 5 MHz or 10 MHz of allocated bandwidth.
- Step 4 Measure and note the actual maximum output power level (P_{max}) for compliance with maximum output power tolerance to the declared nominal maximum output power (P_{nom}) of clause 4.2.5.
- Step 5 Repeat Steps 3 and 4 at the middle and highest RF channel centre frequencies from the declared range.
- Step 6 Repeat Steps 1 to 5 under extreme environmental conditions TL/VL, TL/VH, TH/VL and TH/VH (see annex B) for one RF channel centre frequency from the declared range only.
- Step 7 End of test.

5.4.4.2 Test requirements

For the BS UUT the maximum power levels recorded in the steps above for each of the RF channel centre frequencies and environmental conditions shall meet the requirements of clause 4.2.5.2 for each BCI supported.

5.4.5 Transmit Intermodulation

The purpose of this test is to verify compliance with the transmit intermodulation requirements of clause 4.2.6.

5.4.5.1 Method of measurement

Figure 5.4.5.1-1 shows the test setup for testing BS transmitter intermodulation requirement.

In the case that BS supports multiple transmit antenna, Steps 1 to 6 below shall be performed on a selected single antenna port. Unused ports shall be properly terminated.

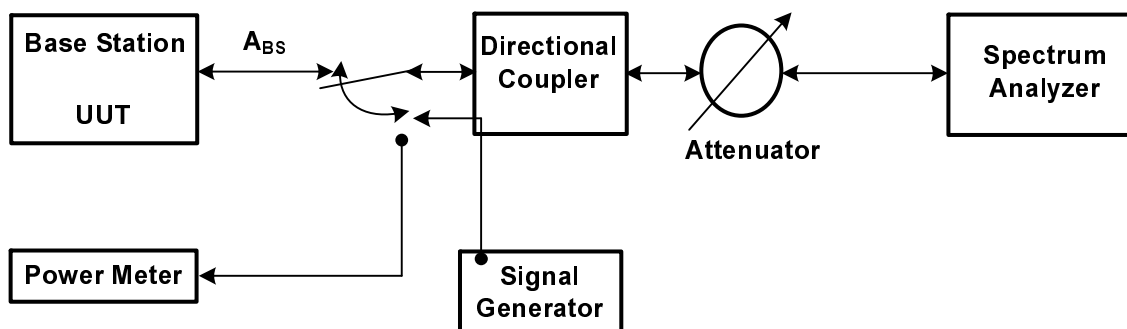

Figure 5.4.5.1-1: Test Setup for transmit intermodulation testing

5.4.5.1.1 Initial conditions

Configure the signal generator to produce an interference signal with a mean power level of 30 dB lower at the BS UUT antenna connector than that of the BS UUT transmitted signal. The interference signal shall utilise modulation and coding equal to those of the BS transmitted signal, and the active time slots of both signals shall be synchronized.

The BS UUT shall be configured to operate at the P_{nom} level declared for the equipment.

Switch on the interfering signal.

5.4.5.1.2 Procedure

- Step 1 For the 5 MHz channel bandwidth case set the centre frequency of the interference signal to be -5 MHz offset from the BS transmitted signal centre frequency. For the 10 MHz channel bandwidth case, set the centre frequency of the interference signal to be -10 MHz offset from the BS transmitted signal centre frequency.
- Step 2 Apply the test procedures described in clauses 5.4.1.1, 5.4.2.1 and 5.4.3.1 at the frequencies of all third and fifth order intermodulation products. The frequency band occupied by the interference signal is excluded from the measurements.
- Step 3 Repeat Step 2 with the interfering signal centre frequency offset set to be +5 MHz or +10 MHz with respect to the BS transmitted signal centre frequency according to the system channel bandwidth under test.
- Step 4 Repeat Steps 2 and 3 with the interfering signal centre frequency offset set to be ± 10 MHz and then ± 15 MHz with respect to the BS transmitted signal centre frequency for the 5 MHz channel bandwidth case. For the 10 MHz channel bandwidth case repeat Steps 2 and 3 with the interfering signal centre frequency offset set to be ± 20 MHz and then ± 30 MHz with respect to the BS transmitted signal centre frequency.
- Step 5 End of test.

5.4.5.2 Test requirements

The BS UUT shall meet the requirements of clause 4.2.6.2 for each of the interfering signal offsets identified above for each BCI supported.

5.4.6 Receiver spurious emissions

The purpose of this test is to verify compliance of BS equipment to the receiver spurious emission requirements of clause 4.2.7.

5.4.6.1 Method of measurement

Figure 5.4.6.1-1 shows the test setup for testing the BS transmitter spurious emission requirement.

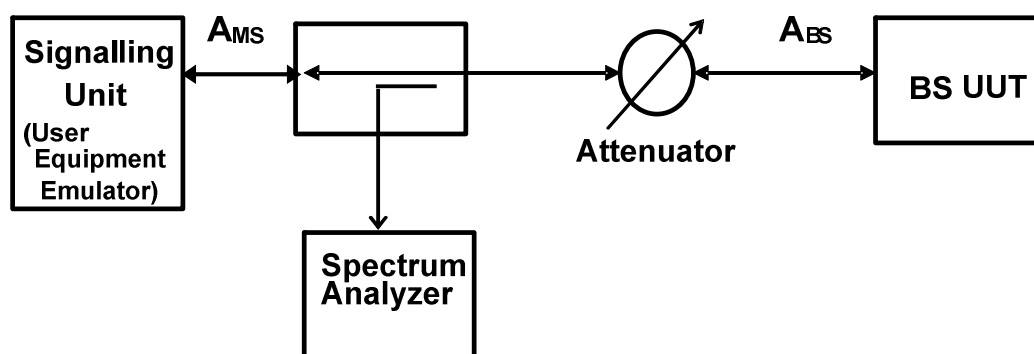

Figure 5.4.6.1-1: Test Setup for BS receiver spurious emission measurement

5.4.6.1.1 Initial conditions

In the spectrum analyzer, set the measurement bandwidth as specified in the relevant table of clause 4.2.7. Set the video bandwidth to a value of three times the measurement bandwidth. True RMS detector shall be used.

5.4.6.1.2 Procedure

- | | |
|--------|---|
| Step 1 | Set the UUT to the RF channel corresponding to the lowest channel centre frequency from the declared range. |
| Step 2 | Ensure the data link connection has been established between BS UUT and Signalling Unit. |
| Step 3 | The BS UUT is configured to transmit at its P _{nom} output power as measured over the 5 MHz or 10 MHz of allocated bandwidth. |
| Step 4 | Measure and note the BS receiver spurious emissions over the range specified in clause 4.2.7 according to the specified measurement bandwidths in the table. The receiver spurious emission measurements should be only taken during the receive part of the TDD frame. |
| Step 5 | Repeat Steps 2 to 4 at middle and highest RF channel center frequencies from the declared range. |
| Step 6 | End of test. |

5.4.6.2 Test requirements

For the BS UUT the measured receiver spurious emission levels recorded in the steps above for each of the RF channel centre frequencies shall meet the requirements of clause 4.2.7.2 for each BCI supported.

5.4.7 Receiver blocking characteristics

The purpose of this test is to verify compliance of BS equipment to the receiver blocking characteristic requirements of clause 4.2.8.

5.4.7.1 Method of Measurement

For Case 1 and Case 2 in table 4.2.8.2-1 or 4.2.8.2-2, the interfering source shall be a conforming unsynchronized signal with the same signalling technology as the in-channel signal. For Case 3 in table 4.2.8.2-1 or 4.2.8.2-2, the interfering source shall consist of a CW signal.

In the case that the BS supports multiple receive antennas (antenna 1 to N), a single channel is connected to the multiple antenna ports through a splitter. In this case, the test system is calibrated to the antenna ports to take into account splitter losses and identical signals and power levels ($\pm 0,3$ dB) are applied to each antenna port.

Figure 5.4.7.1-1 shows the test setup for the receiver blocking test.

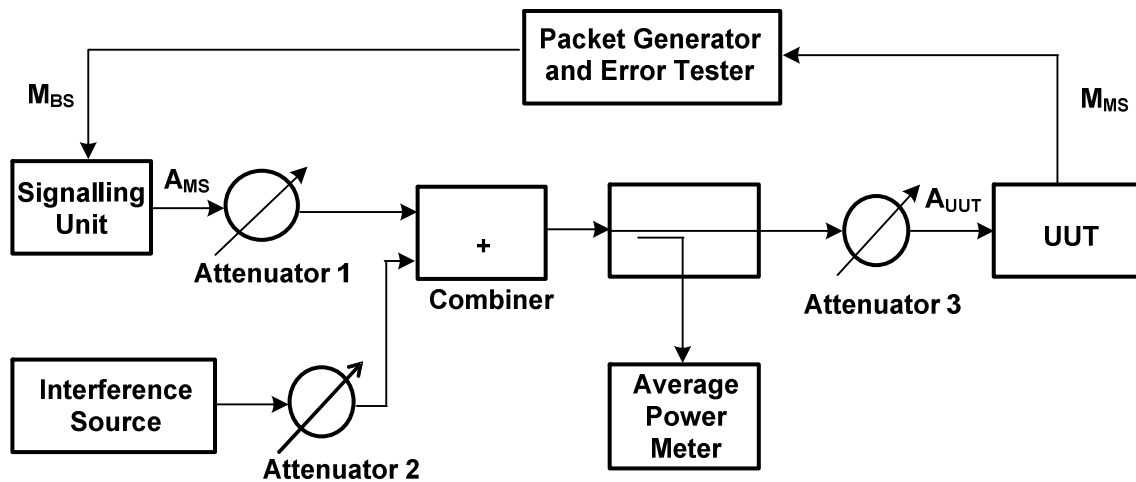

Figure 5.4.7.1-1: Test Setup for BS receiver blocking measurement

5.4.7.1.1 Initial conditions

For Case 1 and Case 2 set the interfering signal source bandwidth to be the same as the in-channel operating bandwidth and operating on an interfering source centre frequency in accordance with table 4.2.8.2-1 or 4.2.8.2-2 according to the system channel bandwidth and BCI under test. Set the interfering signal mean power to the level identified in table 4.2.8.2-1 or 4.2.8.2-2 according to the system channel bandwidth under test.

For Case 3 set the CW signal source to an interfering source centre frequency in accordance with table 4.2.8.2-1 or 4.2.8.2-2 according to the system channel bandwidth and BCI under test. Set the interfering signal mean power to the level identified in table 4.2.8.2-1 or 4.2.8.2-2 according to the system channel bandwidth under test.

Turn the interfering source off.

5.4.7.1.2 Procedure

- Step 1 Set the UUT and signalling unit to the RF channel corresponding to the lowest channel centre frequency from the declared range.
- Step 2 Adjust the received signal level at A_{UUT} to be 6 dB above the sensitivity level P_{SENS5} or P_{SENS10} . Note the signal level is measured over the time period of the data burst only within the downlink transmission.
- Step 3 Turn on the interfering source.
- Step 4 Step the interfering signal generator frequency through the frequency range indicated in either table 4.2.8.2-1 or 4.2.8.2-2 according to the system channel bandwidth and BCI under test, with a step size of 1 MHz.
- Step 5 Measure the BER of the desired signal received for each step of the interfering frequency and record the results.
- Step 6 Turn the interference source off.
- Step 7 Repeat Steps 2 to 6 at middle and highest channel centre frequencies for the desired received signal from the declared range.
- Step 8 Reset the initial conditions as appropriate and repeat Steps 1 to 7 with the interfering signal mean power and centre frequencies set in accordance with Cases 2 and 3 in either table 4.2.8.2-1 or 4.2.8.2-2 according to the system channel bandwidth and BCI under test.
- Step 9 End of test.

5.4.7.2 Test requirements

For the BS UUT, the worst case BER measurement recorded in the steps above for each step of the interfering signal and at each of the RF channel centre frequencies shall meet the requirements of clause 4.2.8.2 for each BCI supported.

5.4.8 Receiver Intermodulation characteristics

The purpose of this test is to verify compliance of BS equipment to the receiver intermodulation characteristic requirements of clause 4.2.9.

5.4.8.1 Method of measurement

The interfering source shall be a conforming unsynchronized signal with the same signalling technology as the in-channel signal.

In the case that the BS supports multiple receive antennas (antenna 1 to N), a single channel is connected to the multiple antenna ports through a splitter. In this case, the test system is calibrated to the antenna ports to take into account splitter losses and identical signals and power levels ($\pm 0,3$ dB) are applied to each antenna port.

Figure 5.4.8.1-1 shows the test setup for the receiver blocking test.

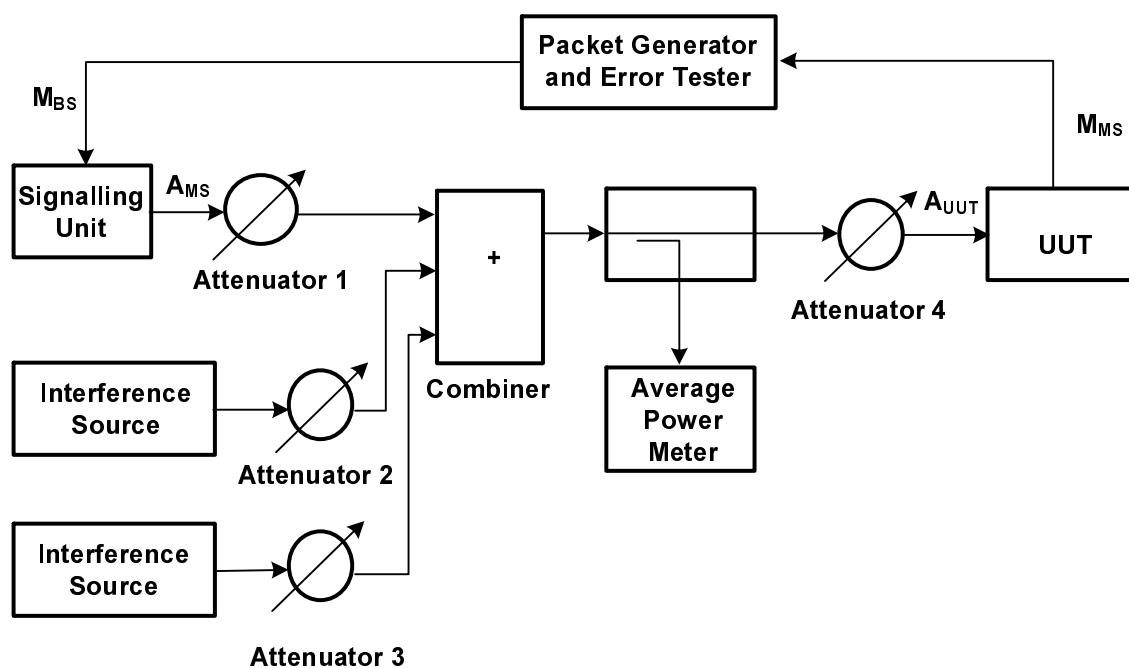

Figure 5.4.8.1-1: Test setup for receiver intermodulation response test

5.4.8.1.1 Initial conditions

Set the modulated interfering signal source bandwidth to be the same as the in-channel operating bandwidth. Set the interfering source centre frequency to have a positive frequency offset from the upper wanted channel edge in accordance with table 4.2.9.2-1 or 4.2.9.2-2 according to the system channel bandwidth under test. Set the modulated interfering signal mean power to the level identified in table 4.2.9.2-1 or 4.2.9.2-2 according to the system channel bandwidth under test.

Set the CW interfering signal frequency to have a positive frequency offset from the upper wanted channel edge in accordance with table 4.2.9.2-1 or 4.2.9.2-2 according to the system channel bandwidth under test. Set the CW interfering signal mean power to the level identified in table 4.2.9.2-1 or 4.2.9.2-2 according to the system channel bandwidth under test.

Turn the interfering sources off.

5.4.8.1.2 Procedure

- Step 1 Set the UUT and signalling unit to the RF channel corresponding to the lowest channel centre frequency from the declared range.
- Step 2 Adjust the received signal level at A_{UUT} to be 6 dB above the sensitivity level $P_{\text{SENS}} + 6$ dB. Note the signal level is measured over the time period of the data burst only within the downlink transmission.
- Step 3 Turn on the interfering sources.
- Step 4 Measure the BER of the desired signal received and record the results.
- Step 5 Turn the interfering sources off.
- Step 6 Reconfigure the interfering sources to transmit with negative frequency offsets from the lower wanted channel edge as defined in table 4.2.9.2-1 or 4.2.9.2-2 according to the system channel bandwidth under test.
- Step 7 Turn on the interfering sources.
- Step 8 Measure the BER of the desired signal received and record the results.
- Step 9 Turn the interfering sources off.
- Step 10 Repeat the test procedure at middle and highest channel centre frequencies for the desired received signal from the declared range.
- Step 11 End of test.

5.4.8.2 Test requirements

For the BS UUT the worst case BER measurement recorded in the steps above for each of the RF channel centre frequencies shall meet the requirements of clause 4.2.9 for each BCI supported.

5.4.9 Receiver adjacent channel selectivity

The purpose of this test is to verify compliance of BS equipment to the receiver adjacent channel selectivity requirements of clause 4.2.10.

5.4.9.1 Method of measurement

The interfering source shall be a conforming unsynchronized signal with the same signalling technology as the in-channel signal.

Figure 5.4.9.1-1 shows the test setup for testing the BS receiver adjacent channel selectivity.

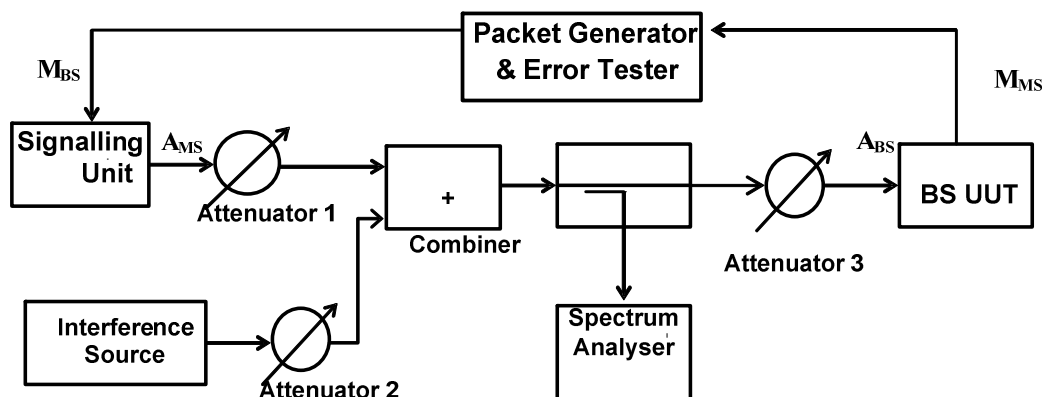

Figure 5.4.9.1-1: Test Setup for BS receiver adjacent channel selectivity measurement

5.4.9.1.1 Initial conditions

Set the interfering source to the first adjacent channel operating frequency in accordance with table 4.2.10.2-1. Set the interfering signal source bandwidth to be the same as the in-channel operating bandwidth. Turn the interfering source off.

5.4.9.1.2 Procedure

- Step 1 Set the UUT and signalling unit to the RF channel corresponding to the lowest channel centre frequency from the declared range.
- Step 2 Adjust the received signal level at A_{UUT} to be 3 dB above the sensitivity level P_{SENS} . Note the signal level is measured over the time period of the data burst only within the downlink transmission.
- Step 3 Turn on the interfering source.
- Step 4 Increase the interfering source power to the appropriate adjacent channel power level identified in table 4.2.10.2-1.
- Step 5 Perform a BER measurement and record the results.
- Step 6 Turn the interference source off.
- Step 7 Set the interfering source to the second adjacent channel operating frequency. Repeat Steps 2 to 6 above for the second adjacent channel test cases and record the results.
- Step 8 Reset the interfering source to the first adjacent channel operating frequency and repeat Steps 2 to 7 at the middle and highest RF channel center frequencies from the declared range.
- Step 9 End of test.

5.4.9.2 Test requirements

For the BS UUT the worst case BER measurement recorded in steps above for each of the RF channel centre frequencies shall meet the requirements of clause 4.2.10 for each BCI supported.

Annex A (normative): HS Requirements and conformance Test specifications Table (HS-RTT)

The HS Requirements and conformance Test specifications Table (HS-RTT) in table A.1 serves a number of purposes, as follows:

- it provides a statement of all the requirements in words and by cross reference to (a) specific clause(s) in the present document or to (a) specific clause(s) in (a) specific referenced document(s);
- it provides a statement of all the test procedures corresponding to those requirements by cross reference to (a) specific clause(s) in the present document or to (a) specific clause(s) in (a) specific referenced document(s);
- it qualifies each requirement to be either:
 - Unconditional: meaning that the requirement applies in all circumstances; or
 - Conditional: meaning that the requirement is dependent on the manufacturer having chosen to support optional functionality defined within the schedule;
- in the case of Conditional requirements, it associates the requirement with the particular optional service or functionality;
- it qualifies each test procedure to be either:
 - Essential: meaning that it is included with the Essential Radio Test Suite and therefore the requirement shall be demonstrated to be met in accordance with the referenced procedures;
 - Other: meaning that the test procedure is illustrative but other means of demonstrating compliance with the requirement are permitted.

Table A.1: HS Requirements and conformance Test specifications Table (HS-RTT)

| Harmonized Standard EN 301 908-20 | | | | | | |
|---|--|-----------------------------|-----------------------------------|------------------|---------------------------|-----------------------------|
| The following requirements and test specifications are relevant to the presumption of conformity under article 3.2 of the R&TTE Directive [i.2] | | | | | | |
| Requirement | | | Requirement Conditionality | | Test Specification | |
| No | Description | Reference: Clause No | U/C | Condition | E/O | Reference: Clause No |
| 1 | Transmitter Spectrum Emission Mask | 4.2.2 | U | | E | 5.4.1 |
| 2 | Transmitter adjacent channel leakage power ratio | 4.2.3 | U | | E | 5.4.2 |
| 3 | Transmitter spurious emissions | 4.2.4 | U | | E | 5.4.3 |
| 4 | Base Station Maximum output power | 4.2.5 | U | | E | 5.4.4 |
| 5 | Transmit Intermodulation | 4.2.6 | U | | E | 5.4.5 |
| 6 | Receiver spurious emissions | 4.2.7 | U | | E | 5.4.6 |
| 7 | Receiver blocking characteristics | 4.2.8 | U | | E | 5.4.7 |
| 8 | Receiver intermodulation characteristics | 4.2.9 | U | | E | 5.4.8 |
| 9 | Receiver adjacent channel selectivity | 4.2.10 | U | | E | 5.4.9 |

Key to columns:**Requirement:**

No A unique identifier for one row of the table which may be used to identify a requirement or its test specification.

Description A textual reference to the requirement.

Clause Number Identification of clause(s) defining the requirement in the present document unless another document is referenced explicitly.

Requirement Conditionality:

U/C Indicates whether the requirement is to be *unconditionally* applicable (U) or is *conditional* upon the manufacturers claimed functionality of the equipment (C).

Condition Explains the conditions when the requirement shall or shall not be applicable for a technical requirement which is classified "conditional".

Test Specification:

E/O Indicates whether the test specification forms part of the Essential Radio Test Suite (E) or whether it is one of the Other Test Suite (O).

NOTE: All tests whether "E" or "O" are relevant to the requirements. Rows designated "E" collectively make up the Essential Radio Test Suite; those designated "O" make up the Other Test Suite; for those designated "X" there is no test specified corresponding to the requirement. The completion of all tests classified "E" as specified with satisfactory outcomes is a necessary condition for a presumption of conformity. Compliance with requirements associated with tests classified "O" or "X" is a necessary condition for presumption of conformity, although conformance with the requirement may be claimed by an equivalent test or by manufacturer's assertion supported by appropriate entries in the technical construction file.

Clause Number Identification of clause(s) defining the test specification in the present document unless another document is referenced explicitly. Where no test is specified (that is, where the previous field is "X") this field remains blank.

Annex B (normative): Environmental profile

The following environmental conditions may be declared by the manufacturer:

- barometric pressure: minimum and maximum;
- temperature: normal and minimum/maximum extremes;
- relative humidity: minimum and maximum;
- power supply: normal and lower/upper voltage extremes.

Where an extreme environment is required then the various combinations of extreme temperatures together with the extreme voltages are shown below:

- Low extreme Temperature/Low extreme Voltage (TL/VL);
- Low extreme Temperature/High extreme Voltage (TL/VH);
- High extreme Temperature/Low extreme Voltage (TH/VL);
- High extreme Temperature/High extreme Voltage (TH/VH).

Annex C (informative):
Void

Annex D (informative): Bibliography

- Directive 2004/108/EC of the European Parliament and of the Council of 15 December 2004 on the approximation of the laws of the Member States relating to electromagnetic compatibility and repealing Directive 89/336/EEC (EMC Directive).
- Directive 2006/95/EC of the European Parliament and of the Council of 12 December 2006 on the harmonisation of the laws of Member States relating to electrical equipment designed for use within certain voltage limits (LV Directive).
- WiMAX Forum® Air Interface specifications WMF-T23-005-R015v06: "WiMAX Forum® Mobile Radio Specification".

History

| Document history | | |
|-------------------------|----------------|---|
| V5.2.1 | September 2011 | Publication |
| V6.1.1 | February 2013 | EN Approval Procedure AP 20130608: 2013-02-08 to 2013-06-10 |
| V6.2.1 | June 2013 | Publication |
| | | |
| | | |