

# ETSI EN 301 908-19 V5.2.1 (2011-09)



Harmonized European Standard

**IMT cellular networks;  
Harmonized EN covering the essential requirements  
of article 3.2 of the R&TTE Directive;  
Part 19: OFDMA TDD WMAN (Mobile WiMAX)  
TDD User Equipment (UE)**

---

Reference

DEN/MSG-TFES-009-19

---

Keywords

IMT, IMT-2000, mobile, OFDMA, radio,  
regulation, TDD, WiMAX, WMAN

**ETSI**

650 Route des Lucioles  
F-06921 Sophia Antipolis Cedex - FRANCE

Tel.: +33 4 92 94 42 00 Fax: +33 4 93 65 47 16

Siret N° 348 623 562 00017 - NAF 742 C  
Association à but non lucratif enregistrée à la  
Sous-Préfecture de Grasse (06) N° 7803/88

---

**Important notice**

Individual copies of the present document can be downloaded from:

<http://www.etsi.org>

The present document may be made available in more than one electronic version or in print. In any case of existing or perceived difference in contents between such versions, the reference version is the Portable Document Format (PDF). In case of dispute, the reference shall be the printing on ETSI printers of the PDF version kept on a specific network drive within ETSI Secretariat.

Users of the present document should be aware that the document may be subject to revision or change of status. Information on the current status of this and other ETSI documents is available at

<http://portal.etsi.org/tb/status/status.asp>

If you find errors in the present document, please send your comment to one of the following services:

[http://portal.etsi.org/chaicor/ETSI\\_support.asp](http://portal.etsi.org/chaicor/ETSI_support.asp)

---

**Copyright Notification**

No part may be reproduced except as authorized by written permission.  
The copyright and the foregoing restriction extend to reproduction in all media.

© European Telecommunications Standards Institute 2011.  
All rights reserved.

DECT™, PLUGTESTS™, UMTS™ and the ETSI logo are Trade Marks of ETSI registered for the benefit of its Members.  
3GPP™ and LTE™ are Trade Marks of ETSI registered for the benefit of its Members and  
of the 3GPP Organizational Partners.  
GSM® and the GSM logo are Trade Marks registered and owned by the GSM Association.

# Contents

Intellectual Property Rights .....	6
Foreword.....	6
Introduction .....	7
1 Scope .....	8
2 References .....	8
2.1 Normative references .....	8
2.2 Informative references.....	8
3 Definitions, symbols and abbreviations .....	9
3.1 Definitions .....	9
3.2 Symbols.....	9
3.3 Abbreviations .....	10
4 Essential requirements specification .....	10
4.1 Environmental profile.....	10
4.2 Conformance requirements .....	11
4.2.1 Introduction.....	11
4.2.2 Transmitter Maximum Output Power .....	11
4.2.2.1 Definition .....	11
4.2.2.2 Limits .....	11
4.2.2.3 Conformance.....	11
4.2.3 Transmitter Spectrum Emission Mask.....	11
4.2.3.1 Definition .....	11
4.2.3.2 Limits .....	11
4.2.3.2.1 Requirements for 5 MHz channel bandwidth.....	12
4.2.3.2.2 Requirements for 10 MHz channel bandwidth.....	12
4.2.3.3 Conformance.....	12
4.2.4 Transmitter Spurious Emissions .....	12
4.2.4.1 Definition .....	12
4.2.4.2 Limits .....	12
4.2.4.2.1 Requirements for 5 MHz channel bandwidth.....	13
4.2.4.2.2 Requirements for 10 MHz channel bandwidth.....	13
4.2.4.2.3 Requirements for UE Coexistence.....	13
4.2.4.3 Conformance.....	13
4.2.5 Transmitter Minimum Output Power.....	13
4.2.5.1 Definition .....	13
4.2.5.2 Limits .....	13
4.2.5.3 Conformance.....	14
4.2.6 Receiver Adjacent Channel Selectivity (ACS) .....	14
4.2.6.1 Definition .....	14
4.2.6.2 Limits .....	14
4.2.6.3 Conformance.....	14
4.2.7 Receiver Blocking Characteristics .....	14
4.2.7.1 Definition .....	14
4.2.7.2 Limits .....	14
4.2.7.3 Conformance.....	15
4.2.8 Receiver Spurious Response.....	15
4.2.8.1 Definition .....	15
4.2.8.2 Limits .....	15
4.2.8.3 Conformance.....	16
4.2.9 Receiver Intermodulation Characteristics .....	16
4.2.9.1 Definition .....	16
4.2.9.2 Limits .....	16
4.2.9.3 Conformance.....	17
4.2.10 Receiver Spurious Emissions.....	17

4.2.10.1	Definition .....	17
4.2.10.2	Limits .....	17
4.2.10.3	Conformance.....	17
4.2.11	Transmitter Adjacent Channel Leakage Power Ratio .....	17
4.2.11.1	Definition .....	17
4.2.11.2	Limits .....	17
4.2.11.2.1	Requirements for 5 MHz channel bandwidth .....	17
4.2.11.2.2	Requirements for 10 MHz channel bandwidth .....	17
4.2.11.3	Conformance.....	18
5	Testing for compliance with technical requirements.....	18
5.1	Environmental conditions for testing .....	18
5.2	Product information.....	18
5.3	Interpretation of the measurement results .....	18
5.4	Essential radio test suites.....	19
5.4.1	Transmitter Maximum and Minimum Output Power .....	19
5.4.1.1	Method of measurement.....	19
5.4.1.1.1	Initial conditions .....	20
5.4.1.1.2	Procedure.....	20
5.4.1.2	Test requirements .....	20
5.4.2	Transmitter Spectrum Emission Mask.....	20
5.4.2.1	Method of measurement.....	21
5.4.2.1.1	Initial conditions .....	21
5.4.2.1.2	Procedure.....	21
5.4.2.2	Test requirements .....	22
5.4.3	Transmitter spurious emissions.....	22
5.4.3.1	Method of measurement.....	22
5.4.3.1.1	Initial conditions .....	22
5.4.3.1.2	Procedure.....	23
5.4.3.2	Test requirements.....	23
5.4.4	Receiver Adjacent Channel Selectivity (ACS) .....	23
5.4.4.1	Method of measurement.....	23
5.4.4.1.1	Initial conditions .....	24
5.4.4.1.2	Procedure.....	24
5.4.4.2	Test requirements .....	24
5.4.5	Receiver Blocking Characteristics .....	24
5.4.5.1	Method of measurement.....	24
5.4.5.1.1	Initial conditions .....	25
5.4.5.1.2	Procedure.....	25
5.4.5.2	Test requirements .....	25
5.4.6	Receiver Spurious Response.....	26
5.4.6.1	Method of measurement.....	26
5.4.6.1.1	Initial conditions .....	26
5.4.6.1.2	Procedure.....	26
5.4.6.2	Test requirements .....	27
5.4.7	Receiver Intermodulation characteristics .....	27
5.4.7.1	Method of measurement.....	27
5.4.7.1.1	Initial conditions .....	27
5.4.7.1.2	Procedure.....	28
5.4.7.2	Test requirements .....	28
5.4.8	Receiver Spurious Emissions.....	28
5.4.8.1	Method of measurement.....	28
5.4.8.1.1	Initial conditions .....	29
5.4.8.1.2	Procedure.....	29
5.4.8.2	Test requirements .....	29
5.4.9	Transmitter Adjacent Channel Leakage Power Ratio .....	29
5.4.9.1	Method of measurement.....	29
5.4.9.1.1	Initial conditions .....	30
5.4.9.1.2	Procedure.....	30
5.4.9.2	Test requirements .....	31

<b>Annex A (normative):</b>	<b>HS Requirements and conformance Test specifications Table (HS-RTT).....</b>	<b>32</b>
<b>Annex B (normative):</b>	<b>Environmental profile .....</b>	<b>34</b>
<b>Annex C (informative):</b>	<b>The EN title in the official languages .....</b>	<b>35</b>
<b>Annex D (informative):</b>	<b>Bibliography.....</b>	<b>36</b>
History .....		37

---

## Intellectual Property Rights

IPRs essential or potentially essential to the present document may have been declared to ETSI. The information pertaining to these essential IPRs, if any, is publicly available for **ETSI members and non-members**, and can be found in ETSI SR 000 314: "*Intellectual Property Rights (IPRs); Essential, or potentially Essential, IPRs notified to ETSI in respect of ETSI standards*", which is available from the ETSI Secretariat. Latest updates are available on the ETSI Web server (<http://ipr.etsi.org>).

Pursuant to the ETSI IPR Policy, no investigation, including IPR searches, has been carried out by ETSI. No guarantee can be given as to the existence of other IPRs not referenced in ETSI SR 000 314 (or the updates on the ETSI Web server) which are, or may be, or may become, essential to the present document.

---

## Foreword

This Harmonized European Standard (EN) has been produced by ETSI Technical Committee Mobile Standards Group (MSG).

The present document has been produced by ETSI in response to mandate M/284 from the European Commission issued under Council Directive 98/34/EC [i.1] (as amended) laying down a procedure for the provision of information in the field of technical standards and regulations.

The title and reference to the present document are intended to be included in the publication in the Official Journal of the European Union of titles and references of Harmonized Standard under the Directive 1999/5/EC [i.2].

See article 5.1 of Directive 1999/5/EC [i.2] for information on presumption of conformity and Harmonised Standards or parts thereof the references of which have been published in the Official Journal of the European Union.

The requirements relevant to Directive 1999/5/EC [i.2] are summarised in annex A.

The present document is part 19 of a multi-part deliverable covering the essential requirements under article 3.2 of Directive 1999/5/EC [i.2] for Base Stations (BS), Repeaters and User Equipment (UE) for IMT cellular networks, as identified below:

- Part 1: "Introduction and common requirements";
- Part 2: "CDMA Direct Spread (UTRA FDD) User Equipment (UE)";
- Part 3: "CDMA Direct Spread (UTRA FDD) Base Stations (BS)";
- Part 4: "CDMA Multi-Carrier (cdma2000) User Equipment (UE)";
- Part 5: "CDMA Multi-Carrier (cdma2000) Base Stations (BS)";
- Part 6: "CDMA TDD (UTRA TDD) User Equipment (UE)";
- Part 7: "CDMA TDD (UTRA TDD) Base Stations (BS)";
- Part 8: "Harmonized EN for IMT-2000, TDMA Single-Carrier (UWC 136) (UE) covering essential requirements of article 3.2 of the R&TTE Directive";
- Part 9: "Harmonized EN for IMT-2000, TDMA Single-Carrier (UWC 136) (BS) covering essential requirements of article 3.2 of the R&TTE Directive";
- Part 10: "Harmonized EN for IMT-2000, FDMA/TDMA (DECT) covering essential requirements of article 3.2 of the R&TTE Directive";
- Part 11: "CDMA Direct Spread (UTRA FDD) (Repeaters)";
- Part 12: "Harmonized EN for IMT-2000, CDMA Multi-Carrier (cdma2000) (Repeaters) covering the essential requirements of article 3.2 of the R&TTE Directive";
- Part 13: "Evolved Universal Terrestrial Radio Access (E-UTRA) User Equipment (UE)";

- Part 14: "Evolved Universal Terrestrial Radio Access (E-UTRA) Base Stations (BS)";
- Part 15: "Evolved Universal Terrestrial Radio Access (E-UTRA) (FDD Repeaters)";
- Part 16: "Harmonized EN for IMT-2000, Evolved CDMA Multi-Carrier Ultra Mobile Broadband (UMB) (UE) covering the essential requirements of article 3.2 of the R&TTE Directive";
- Part 17: "Harmonized EN for IMT-2000, Evolved CDMA Multi-Carrier Ultra Mobile Broadband (UMB) (BS) covering the essential requirements of article 3.2 of the R&TTE Directive";
- Part 18: "E-UTRA, UTRA and GSM/EDGE Multi-Standard Radio (MSR) Base Stations (BS)";
- Part 19: "OFDMA TDD WMAN (Mobile WiMAX) TDD User Equipment (UE)";**
- Part 20: "OFDMA TDD WMAN (Mobile WiMAX) TDD Base Station (BS)";
- Part 21: "OFDMA TDD WMAN (Mobile WiMAX) FDD User Equipment (UE)";
- Part 22: "OFDMA TDD WMAN (Mobile WiMAX) FDD Base Stations (BS)".

<b>National transposition dates</b>	
Date of adoption of this EN:	12 September 2011
Date of latest announcement of this EN (doa):	31 December 2011
Date of latest publication of new National Standard or endorsement of this EN (dop/e):	30 June 2012
Date of withdrawal of any conflicting National Standard (dow):	30 June 2013

---

## Introduction

The present document is part of a set of standards developed by ETSI and is designed to fit in a modular structure to cover all radio and telecommunications terminal equipment within the scope of the R&TTE Directive. The modular structure is shown in EG 201 399 [i.3].

# 1 Scope

The present document applies to the following radio equipment type:

- User Equipment for IMT-2000 OFDMA TDD WMAN (Mobile WiMAX) operating in TDD mode.

This radio equipment type is capable of operating in all or any part of the frequency bands given in table 1-1.

**Table 1-1: OFDMA TDD WMAN User Equipment frequency bands**

Mobile WiMAX Band Class Index	IMT-2000 OFDMA TDD WMAN service operating bands	Channel Bandwidth
1B	2 300 MHz to 2 400 MHz	5 MHz and 10 MHz

The present document is intended to cover the provisions of Directive 1999/5/EC [i.2] (R&TTE Directive) article 3.2, which states that "... radio equipment shall be so constructed that it effectively uses the spectrum allocated to terrestrial/space radio communications and orbital resources so as to avoid harmful interference".

In addition to the present document, other ENs that specify technical requirements in respect of essential requirements under other parts of article 3 of the R&TTE Directive 1999/5/EC [i.2] may apply to equipment within the scope of the present document.

NOTE: A list of such ENs is included on the web site <http://www.newapproach.org>.

# 2 References

References are either specific (identified by date of publication and/or edition number or version number) or non-specific. For specific references, only the cited version applies. For non-specific references, the latest version of the reference document (including any amendments) applies.

Referenced documents which are not found to be publicly available in the expected location might be found at <http://docbox.etsi.org/Reference>.

NOTE: While any hyperlinks included in this clause were valid at the time of publication ETSI cannot guarantee their long term validity.

## 2.1 Normative references

The following referenced documents are necessary for the application of the present document.

- [1] ETSI EN 301 908-1 (V5.2.1): "IMT cellular networks; Harmonized EN covering the essential requirements of article 3.2 of the R&TTE Directive; Part 1: Introduction and common requirements".
- [2] CEPT/ERC/Recommendation 74-01E (Siófok 98, Nice 99, Sesimbra 02, Hradec Kralove 05): "Unwanted emissions in the spurious domain".

## 2.2 Informative references

The following referenced documents are not necessary for the application of the present document but they assist the user with regard to a particular subject area.

- [i.1] Directive 98/34/EC of the European Parliament and of the Council of 22 June 1998 laying down a procedure for the provision of information in the field of technical standards and regulations.
- [i.2] Directive 1999/5/EC of the European Parliament and of the Council of 9 March 1999 on radio equipment and telecommunications terminal equipment and the mutual recognition of their conformity (R&TTE Directive).



- [i.3] ETSI EG 201 399: "Electromagnetic compatibility and Radio spectrum Matters (ERM); A guide to the production of Harmonized Standards for application under the R&TTE Directive".
- [i.4] ETSI TR 102 215 (V1.3.1): "Electromagnetic compatibility and Radio spectrum Matters (ERM); Recommended approach, and possible limits for measurement uncertainty for the measurement of radiated electromagnetic fields above 1 GHz".
- [i.5] ETSI EN 300 019-1-0: "Environmental Engineering (EE); Environmental conditions and environmental tests for telecommunications equipment; Part 1-0: Classification of environmental conditions; Introduction".
- [i.6] ETSI TR 100 028 (all parts) (V1.4.1): "Electromagnetic compatibility and Radio spectrum Matters (ERM); Uncertainties in the measurement of mobile radio equipment characteristics".
- [i.7] ITU-R Recommendation SM.329-10 (2003): "Unwanted emissions in the spurious domain".

## 3 Definitions, symbols and abbreviations

### 3.1 Definitions

For the purposes of the present document, the terms and definitions given in the R&TTE Directive 1999/5/EC [i.2] and the following apply:

**burst:** period during which radio waves are intentionally transmitted, preceded and succeeded by periods during which no intentional transmission is made

**environmental profile:** declared range of environmental conditions under which equipment within the scope of the present document is required to be compliant

**integral antenna:** antenna which is declared to be part of the radio equipment by the manufacturer

NOTE: Even when equipment with an integral antenna is concerned, it might still be possible to separate the antenna from the equipment using a special tool. In such cases the assessment of the radio equipment and of the antenna against requirements of the present document may be done separately.

**maximum output power:** mean power level per carrier of the base station measured at the antenna connector in a specified reference condition

**mean power:** when applied to a modulated signal, this is the power (transmitted or received) in a bandwidth

**nominal maximum output power:** maximum nominal mean power level per carrier of the user equipment available at the antenna connector declared by the manufacturer; for equipment implementing dynamic change of modulation format, it is intended as the maximum nominal mean power associated to the modulation format delivering the highest power

**receiver thermal noise power:** equal to  $k \times T \times BW \times F$

**WiMAX:** trademarked name for the OFDMA TDD WMAN IMT technology

### 3.2 Symbols

For the purposes of the present document, the following symbols apply:

$A_{BS}$	Base Station Interface A
$A_{MS}$	Mobile Station Interface A
$A_{UUT}$	Unit Under Test Interface A
BW	Assigned channel bandwidth
dB	Decibel
dBc	Decibel relative to carrier
dBm	Decibel relative to 1 milliwatt

f	Frequency of measurement
$f_c$	Centre frequency of the assigned channel
F	Receiver noise figure
GHz	GigaHertz
k	Boltzmann's constant
$M_{BS}$	Base Station Interface M
MHz	MegaHertz
$M_{MS}$	Mobile Station Interface M
N	Maximum number of antennas in a multiple antenna configuration
$N_{th}$	Receiver thermal noise power expressed in dBm
$P_{SENS}$	Receiver sensitivity level at BER $\leq 10^{-6}$ (or equivalent PER) performance, corresponding to the most robust modulation and coding rate supported by the technology
$P_{SENS5}$	Receiver sensitivity level at BER $10^{-6}$ for a 5 MHz channelized system, corresponding to the most robust modulation and coding rate supported by the technology
$P_{SENS10}$	Receiver sensitivity level at BER $10^{-6}$ for a 10 MHz channelized system, corresponding to the most robust modulation and coding rate supported by the technology
$P_{nom}$	Declared nominal maximum output Power
T	Ambient temperature in Kelvin

### 3.3 Abbreviations

For the purposes of the present document, the following abbreviations apply:

ACLR	Adjacent Channel Leakage power Ratio
ACS	Adjacent Channel Selectivity
BER	Bit Error Ratio
BS	Base Station
CW	Continuous Wave
ERM	Electromagnetic compatibility and Radio spectrum Matters
IMT	International Mobile Telecommunications
MSG	Mobile Standards Group
OFDMA	Orthogonal Frequency Division Multiple Access
PER	Packet Error Ratio
R&TTE	Radio equipment and Telecommunications Terminal Equipment
RF	Radio Frequency
RMS	Root Mean Square
TDD	Time Division Duplexing
TFES	Task Force for European Standards for IMT
UE	User Equipment
UUT	Unit Under Test
WMAN	Wireless Metropolitan Area Network

---

## 4 Essential requirements specification

With reference to article 3.2 of 1999/5/EC Directive [i.2] the phenomena in this clause have been identified as relevant to the essential requirements.

### 4.1 Environmental profile

The technical requirements of the present document apply under the environmental profile for operation of the equipment, which shall be declared by the manufacturer. The equipment shall comply with all the technical requirements of the present document at all times when operating within the boundary limits of the required operational environmental profile.

## 4.2 Conformance requirements

This clause describes the conformance requirements for OFDMA TDD WMAN User Equipment.

### 4.2.1 Introduction

To meet the essential requirement under article 3.2 of Directive 1999/5/EC [i.2] (R&TTE Directive) for IMT-2000 User Equipment (UE) seven essential parameters in addition to those in EN 301 908-1 [1] have been identified. Table 4.2.1-1 provides a cross reference between these seven essential parameters and the corresponding nine technical requirements for equipment within the scope of the present document.

**Table 4.2.1-1: Cross references**

Essential parameter	Corresponding technical requirements
Spectrum emissions mask	4.2.3 Transmitter Spectrum emissions mask
	4.2.11 Transmitter adjacent channel leakage power ratio
Conducted spurious emissions in active mode	4.2.4 Transmitter spurious emissions
Accuracy of maximum output power	4.2.2 Transmitter maximum output power
Prevention of harmful interference through control of power	4.2.5 Transmitter minimum output power
Conducted spurious emission in idle mode	4.2.10 Receiver spurious emissions
Impact of interference on receiver performance	4.2.7 Receiver Blocking characteristics
	4.2.8 Receiver spurious response
	4.2.9 Receiver Intermodulation characteristics
Receiver adjacent channel selectivity	4.2.6 Receiver Adjacent Channel Selectivity (ACS)
Control and Monitoring functions	EN 301 908-1 [1], clause 4.2.4 Control and Monitoring functions

### 4.2.2 Transmitter Maximum Output Power

#### 4.2.2.1 Definition

The UE maximum output power is measured over total allocated channel bandwidth available at the antenna connector.

#### 4.2.2.2 Limits

The UE maximum output power shall not exceed 26 dBm.

#### 4.2.2.3 Conformance

Conformance tests described in clause 5.4.1 shall be carried out.

### 4.2.3 Transmitter Spectrum Emission Mask

#### 4.2.3.1 Definition

Spectrum emission mask defines an out of band emission requirement for the transmitter. These out of band emissions are unwanted emissions outside the channel bandwidth resulting from the modulation process and non-linearity in the transmitter but excluding spurious emissions.

#### 4.2.3.2 Limits

A UE transmitting on a single RF carrier configured in accordance with the manufacturer's specification shall not exceed the allowed level specified in table 4.2.3.2.1-1 or 4.2.3.2.2-1 for the relevant nominal channel bandwidth of 5 MHz or 10 MHz.

Integration bandwidth refers to the frequency range over which the emission power is integrated.

$\Delta f$  is defined as the frequency offset in MHz from the channel centre frequency.

## 4.2.3.2.1 Requirements for 5 MHz channel bandwidth

Table 4.2.3.2.1-1: Spectrum Emission Mask for 5 MHz channel bandwidth

Segment number	Offset from channel centre frequency ( $\Delta f$ ) (MHz)	Integration bandwidth (kHz)	Allowed emission level within the integration bandwidth (dBm)
1	2,5 to < 3,5	50	-13,00
2	3,5 to < 7,5	1 000	-13,00
3	7,5 to < 8	500	-16,00
4	8 to < 10,4	1 000	-25,00
5	10,4 to < 12,5	1 000	-25,00

## 4.2.3.2.2 Requirements for 10 MHz channel bandwidth

Table 4.2.3.2.2-1: Spectrum emission mask for 10 MHz channel bandwidth

Segment number	Offset from channel centre frequency ( $\Delta f$ ) (MHz)	Integration bandwidth (kHz)	Allowed emission level within the integration bandwidth (dBm)
1	5 to < 6	100	-13,00
2	6 to < 10	1 000	-13,00
3	10 to < 11	1 000	-13 - 12( $\Delta f$ - 10)
4	11 to < 15	1 000	-25,00
5	15 to < 20	1 000	-25,00
6	20 to < 25	1 000	-25,00

## 4.2.3.3 Conformance

Conformance tests described in clause 5.4.2 shall be carried out.

## 4.2.4 Transmitter Spurious Emissions

## 4.2.4.1 Definition

Transmitter spurious emissions are emissions which are caused by unwanted transmitter effects such as harmonics emission, parasitic emission, intermodulation products and frequency conversion products, but exclude out of band emissions. The spurious emission limits are specified in terms of general requirements in line with ITU-R Recommendation SM.329-10 [i.7] and frequency range specific requirements to address UE co-existence.

## 4.2.4.2 Limits

The limits of spurious emissions (or more precisely, according latest ITU-R definitions, unwanted emissions in the spurious domain), shall conform to CEPT/ERC Recommendation 74-01 [2].

The following requirements in tables 4.2.4.2.1-1 and 4.2.4.2.2-1 are only applicable for frequencies, which are greater than 250 % of the channel bandwidth (that is 12,5 MHz for the 5 MHz channel bandwidth and 25 MHz for the 10 MHz channel bandwidth) away from the carrier centre frequency. In the following  $f_c$  is the centre frequency of transmit signal and  $f$  is the frequency of spurious emission.

## 4.2.4.2.1 Requirements for 5 MHz channel bandwidth

Table 4.2.4.2.1-1: Spurious Emission requirement for 5 MHz channel bandwidth

Segment	Frequency Range	Measurement Bandwidth	Maximum allowed level (dBm)
1	$9 \text{ kHz} \leq f < 150 \text{ kHz}$	1 kHz	-36
2	$150 \text{ kHz} \leq f < 30 \text{ MHz}$	10 kHz	-36
3	$30 \text{ MHz} \leq f < 1\,000 \text{ MHz}$	100 kHz	-36
4	$1 \text{ GHz} \leq f < 12,75 \text{ GHz}$	30 kHz If $12,5 \leq  f_c - f  < 50$ 300 kHz If $50 \leq  f_c - f  < 60$ 1 MHz If $60 \leq  f_c - f $	-30

## 4.2.4.2.2 Requirements for 10 MHz channel bandwidth

Table 4.2.4.2.2-1: Spurious Emission requirement for 10 MHz channel bandwidth

Segment	Frequency Range	Measurement Bandwidth	Maximum allowed level (dBm)
1	$9 \text{ kHz} \leq f < 150 \text{ kHz}$	1 kHz	-36
2	$150 \text{ kHz} \leq f < 30 \text{ MHz}$	10 kHz	-36
3	$30 \text{ MHz} \leq f < 1\,000 \text{ MHz}$	100 kHz	-36
4	$1 \text{ GHz} \leq f < 12,75 \text{ GHz}$	30 kHz If $25 \leq  f_c - f  < 100$ 300 kHz If $100 \leq  f_c - f  < 120$ 1 MHz If $120 \leq  f_c - f $	-30

## 4.2.4.2.3 Requirements for UE Coexistence

Table 4.2.4.2.3-1: Spurious Emission requirement for UE coexistence

Spurious frequency (f) range (MHz)	Measurement bandwidth (MHz)	Maximum Emission Level (dBm)
$2\,110 \leq f < 2\,170$	1	-50
$1\,805 \leq f < 1\,880$	1	-50
$2\,496 \leq f < 2\,690$	1	-50
$925 \leq f < 960$	1	-50
$1\,900 \leq f < 1\,920$	1	-50
$2\,010 \leq f < 2\,025$	1	-50
$2\,570 \leq f < 2\,620$	1	-50
$791 \leq f < 821$	1	-50

NOTE 1: For 5 MHz channel bandwidth the  $f_c$  ranges from 2 302,5 MHz to 2 397,5 MHz.  
NOTE 2: For 10 MHz channel bandwidth the  $f_c$  ranges from 2 305 MHz to 2 395 MHz.

## 4.2.4.3 Conformance

Conformance tests described in clause 5.4.3 shall be carried out.

## 4.2.5 Transmitter Minimum Output Power

## 4.2.5.1 Definition

The UE minimum output power is measured over total allocated channel bandwidth available at the antenna connector when the power is set to the minimum value.

## 4.2.5.2 Limits

The UE minimum output power shall not exceed -19 dBm.

### 4.2.5.3 Conformance

Conformance tests described in clause 5.4.1 shall be carried out.

## 4.2.6 Receiver Adjacent Channel Selectivity (ACS)

### 4.2.6.1 Definition

Adjacent Channel Selectivity (ACS) is a measure of a receiver's ability to receive a wanted signal at its assigned channel frequency in the presence of an adjacent channel signal at a given frequency offset from the centre frequency of the assigned channel. ACS is the interferer power level (in dBm) relative to thermal noise ( $N_{th}$ ).

### 4.2.6.2 Limits

Table 4.2.6.2-1 specifies the limits and the test parameters for the receiver ACS in the first adjacent channel and 2<sup>nd</sup> adjacent channels for 5 MHz and 10 MHz channel bandwidths. For an assigned channel bandwidth BW, the interferer channel bandwidth is the same. The wanted and interferer power levels are evaluated over 95 % of the BW centred on the wanted or adjacent channel as identified in table 4.2.6.2-1. The compliant system shall be able to meet a Bit Error Ratio (BER)  $< 10^{-6}$  (or equivalent PER) with the interference level in either the first adjacent or second adjacent channel applied as specified in the table. Alternatively depending on packet sizes supported, equivalent Packet Error Ratio (PER) criteria can be used.

**Table 4.2.6.2-1: Limits and test parameters for receiver adjacent channel selectivity**

Description	In-channel	Interferer on 1 <sup>st</sup> adjacent channel	Interferer on 2 <sup>nd</sup> adjacent channel
ACS limits (dB)		33	47
Power (dBm)	$P_{SENS} + 3$	$N_{th} + 33$	$N_{th} + 47$
Centre frequency (MHz)	$f_c$	$f_c \pm BW$	$f_c \pm 2 \times BW$
NOTE: $N_{th}$ is the receiver thermal noise power of the equipment (in dBm) as declared by the manufacturer.			

### 4.2.6.3 Conformance

Conformance tests described in clause 5.4.4 shall be carried out.

## 4.2.7 Receiver Blocking Characteristics

### 4.2.7.1 Definition

The blocking characteristic is a measure of the receiver's ability to receive a wanted signal at its assigned channel frequency in the presence of an unwanted interferer on frequencies other than those of the spurious response or the adjacent channels, without this unwanted input signal causing a degradation of the performance of the receiver beyond a specified limit. The blocking performance shall apply at all frequencies except those at which a spurious response occur.

$P_{SENS5}$  and  $P_{SENS10}$  are the sensitivity levels at  $BER \leq 10^{-6}$ , for 5 MHz and 10 MHz channels respectively, corresponding to the most robust modulation and coding rate supported by the user equipment. The wanted signal with the most robust modulation and coding supported by the UE shall be used.

### 4.2.7.2 Limits

The wanted signal with the most robust modulation and coding supported by the UE shall be used.

BER performance requirement at  $BER \leq 10^{-6}$  (or equivalent PER) shall be met when the following signals are coupled to UE antenna input.

- A wanted signal at the assigned channel frequency, with mean power 6 dB above  $P_{SENS5}$ .

- Interfering signal with the following parameters.

**Table 4.2.7.2-1: Blocking for 5 MHz channel bandwidth**

Centre frequency of interfering signal	Interfering signal mean power	Minimum offset of interfering signal centre frequency from the lower and upper channel edge	Type of interfering signal
2 300 MHz to 2 400 MHz	-49 dBm	12,5 MHz	Modulation and coding equal to those of the wanted signal

BER performance requirement at  $BER \leq 10^{-6}$  (or equivalent PER) shall be met when the following signals are coupled to UE antenna input.

- A wanted signal at the assigned channel frequency, with mean power 6 dB above  $P_{SENS10}$ .
- Interfering signal with the following parameters.

**Table 4.2.7.2-2: Blocking for 10 MHz channel bandwidth**

Centre frequency of interfering signal	Interfering signal mean power	Minimum offset of interfering signal centre frequency from the lower and upper channel edge	Type of interfering signal
2 300 MHz to 2 400 MHz	-49 dBm	25 MHz	Modulation and coding equal to those of the wanted signal

### 4.2.7.3 Conformance

Conformance tests described in clause 5.4.5 shall be carried out.

## 4.2.8 Receiver Spurious Response

### 4.2.8.1 Definition

Spurious response is a measure of the receiver's ability to receive a wanted signal on its assigned channel frequency without exceeding a given degradation due to the presence of an unwanted CW interfering signal at any other frequency at which a response is obtained i.e. for which the blocking limit as specified in table 4.2.7.2-1 or 4.2.7.2-2 is not met.

### 4.2.8.2 Limits

BER performance requirement at  $BER \leq 10^{-6}$  (or equivalent PER) shall be met when the following signals are coupled to UE antenna input.

- A wanted signal at the assigned channel frequency, with mean power 6 dB above  $P_{SENS5}$ .

**Table 4.2.8.2-1: Receiver spurious response for 5 MHz channel bandwidth**

Centre frequency of interfering signal	Interfering signal mean power	Type of interfering signal
2 300 MHz to 2 400 MHz	-49 dBm	CW

BER performance requirement at  $BER \leq 10^{-6}$  (or equivalent PER) shall be met when the following signals are coupled to UE antenna input.

- A wanted signal at the assigned channel frequency, with mean power 6 dB above  $P_{SENS10}$ .

**Table 4.2.8.2-2: Receiver spurious response for 10 MHz channel bandwidth**

Centre frequency of interfering signal	Interfering signal mean power	Type of interfering signal
2 300 MHz to 2 400 MHz	-49 dBm	CW

### 4.2.8.3 Conformance

Conformance tests described in clause 5.4.6 shall be carried out.

## 4.2.9 Receiver Intermodulation Characteristics

### 4.2.9.1 Definition

Third and higher order mixing of two interfering RF signals can produce an interfering signal in the band of the desired channel. Intermodulation response rejection is a measure of the capability of the receiver to receive a wanted signal on its assigned channel frequency in the presence of two or more interfering signals which have a specific frequency relationship to the wanted signal.

### 4.2.9.2 Limits

BER performance requirement at  $BER \leq 10^{-6}$  (or equivalent PER) shall be met when the following signals are coupled to UE antenna input.

- A wanted signal at the assigned channel frequency, with mean power 6 dB above  $P_{SENS5}$ .
- Two interfering signals with the following parameters.

**Table 4.2.9.2-1: Receiver intermodulation characteristics for 5 MHz channel bandwidth**

Interfering signal mean power	Offset of interfering signal centre frequency from the channel edge	Type of interfering signal
-55 dBm	7,5 MHz	CW signal
-55 dBm	17,5 MHz	Modulation and coding equal to those of the wanted signal

BER performance requirement at  $BER \leq 10^{-6}$  (or equivalent PER) shall be met when the following signals are coupled to UE antenna input.

- A wanted signal at the assigned channel frequency, with mean power 6 dB above  $P_{SENS10}$ .
- Two interfering signals with the following parameters.

**Table 4.2.9.2-2: Receiver intermodulation characteristics for 10 MHz channel bandwidth**

Interfering signal mean power	Offset of interfering signal centre frequency from the channel edge	Type of interfering signal
-55 dBm	15 MHz	CW signal
-55 dBm	35 MHz	Modulation and coding equal to those of the wanted signal



### 4.2.9.3 Conformance

Conformance tests described in clause 5.4.7 shall be carried out.

## 4.2.10 Receiver Spurious Emissions

### 4.2.10.1 Definition

The spurious emissions power is the power of emissions generated or amplified in a receiver that appear at the UE antenna connector.

### 4.2.10.2 Limits

The measured spurious emissions derived in clause 5.3.9 conform to CEPT/ERC Recommendation 74-01 [2] and shall not exceed the maximum level specified in table 4.2.10.2-1.

**Table 4.2.10.2-1: General receiver spurious emission requirements**

Frequency Band	Measurement bandwidth	Maximum level
$30 \text{ MHz} \leq f < 1 \text{ GHz}$	100 kHz	-57 dBm
$1 \text{ GHz} \leq f \leq 12,75 \text{ GHz}$	1 MHz	-47 dBm

### 4.2.10.3 Conformance

Conformance tests described in clause 5.4.8 shall be carried out.

## 4.2.11 Transmitter Adjacent Channel Leakage Power Ratio

### 4.2.11.1 Definition

Adjacent Channel Leakage power Ratio (ACLR) is the ratio of the filtered mean power centred on the assigned channel frequency to the filtered mean power centred on an adjacent channel frequency.

### 4.2.11.2 Limits

The requirements in tables 4.2.11.2.1-1 and 4.2.11.2.2-1 are based upon a measurement filter characteristic that is rectangular with a width dependent upon the UE channel bandwidth.

#### 4.2.11.2.1 Requirements for 5 MHz channel bandwidth

**Table 4.2.11.2.1-1: ACLR requirement for 5 MHz channel bandwidth**

Adjacent channel centre frequency	Minimum required ACLR relative to assigned channel frequency (dB)	Measurement filter width (MHz)
UE channel centre frequency $\pm 5 \text{ MHz}$	29,2	4,75
UE channel centre frequency $\pm 10 \text{ MHz}$	43,2	4,75

#### 4.2.11.2.2 Requirements for 10 MHz channel bandwidth

**Table 4.2.11.2.2-1: ACLR requirement for 10 MHz channel bandwidth**

Adjacent channel centre frequency	Minimum required ACLR relative to assigned channel frequency (dB)	Measurement filter width (MHz)
UE channel centre frequency $\pm 10 \text{ MHz}$	29,2	9,5
UE channel centre frequency $\pm 20 \text{ MHz}$	43,2	9,5

### 4.2.11.3 Conformance

Conformance tests described in clause 5.4.9 shall be carried out.

---

## 5 Testing for compliance with technical requirements

### 5.1 Environmental conditions for testing

The technical requirements of the present document apply under the environmental profile, for intended operation of the equipment and antennas, declared by the manufacturer.

The environmental profile may be determined by the environmental class of the equipment according to the guidance given in EN 300 019-1-0 [i.5].

The combination of the equipment and its antennas shall comply with all the requirements of the present document at all times when operating within the boundary limits of the declared operational environmental profile.

### 5.2 Product information

The following information shall be stated by the manufacturer in order to carry out the test suites:

- the operating RF channel centre frequency range of the equipment;
- the nominal occupied channel bandwidth;
- the modulation format(s) employed by the equipment;
- the nominal maximum output power ( $P_{nom}$ ) from the equipment and power class;
- the operational environmental profile(s) applicable to the equipment;
- the receiver sensitivity levels  $P_{SENS5}$  and  $P_{SENS10}$  and the equipment receiver thermal noise power  $N_{th}$  (in dBm).

### 5.3 Interpretation of the measurement results

The interpretation of the results recorded in a test report for the measurements described in the present document shall be as follows:

- the measured value related to the corresponding limit shall be used to decide whether the user equipment meets the requirements of the present document;
- the value of the measurement uncertainty for the measurement of each parameter shall be documented in the test report;
- the recorded value of the measurement uncertainty shall be, for each measurement, equal to or lower than the figures in table 5.3-1.

For the test methods, according to the present document, the measurement uncertainty figures shall be calculated and shall correspond to an expansion factor (coverage factor)  $k = 1,96$  (which provides a confidence level of 95 % in the case where the distributions characterizing the actual measurement uncertainties are normal (Gaussian)). Principles for the calculation of measurement uncertainty are contained in TR 100 028 [i.6] or TR 102 215 [i.4].

Table 5.3-1 is based on such expansion factors.

**Table 5.3-1: Maximum measurement uncertainty of the test system**

Parameter	Conditions	Uncertainty
Maximum output power tolerance		±0,7 dB
Spectrum emission mask		±1,5 dB
Transmitter Spurious Emissions	9 kHz < f ≤ 4 GHz: 4 GHz < f ≤ 12,75 GHz:	±2,0 dB ±4,0 dB
Transmitter Minimum Output Power		±1,0 dB
Receiver Adjacent Channel Selectivity (ACS)		±1,1 dB
Receiver Blocking Characteristics		±1,3 dB
Receiver Spurious Response		±1,3 dB
Receiver Intermodulation Characteristics		±1,4 dB
Receiver spurious emissions	30 MHz ≤ f ≤ 4,0 GHz: 4 GHz < f ≤ 12,75 GHz:	±2,0 dB ±4,0 dB
Transmitter adjacent channel leakage power ratio		±0,8 dB
NOTE 1: For RF tests it should be noted that the uncertainties in table 5.3-1 apply to the test system operating into a nominal 50 Ω load and do not include system effects due to mismatch between the EUT and the test system.		
NOTE 2: If the test system for a test is known to have a measurement uncertainty greater than that specified in table 5.3-1, this equipment can still be used provided that an adjustment is made follows: any additional uncertainty in the test system over and above that specified in table 5.3-1 should be used to tighten the test requirements - making the test harder to pass (for some tests, e.g. receiver tests, this may require modification of stimulus signals). This procedure will ensure that a test system not compliant with table 5.3-1 does not increase the probability of passing an EUT that would otherwise have failed a test if a test system compliant with table 5.3-1 had been used.		

## 5.4 Essential radio test suites

All tests are carried out under normal environmental conditions unless otherwise specified.

### 5.4.1 Transmitter Maximum and Minimum Output Power

The purpose of this test is to verify compliance of UE equipment transmitter maximum output power and minimum transmit power control in support of the requirements of clauses 4.2.2 and 4.2.5.

#### 5.4.1.1 Method of measurement

Figure 5.4.1.1-1 shows the test setup for testing UE nominal maximum and minimum output transmitter power.

In the case that UE supports multiple transmit antenna (antenna 1 to N):

- 1) If single transmit antenna is a valid mode of operation, steps 1 to 9 below shall be performed on a selected single antenna port.
- 2) To test the mode with multiple antenna enabled:
  - a) Steps 1 to 9 below shall be repeated when all antenna are enabled (e.g. each antenna is transmitting at  $P_{nom} - 10\log_{10}(N)$  level).
  - b) Step 4 is modified to include total combined power (measured power levels are added over N antenna).
  - c) Step 6 is modified to include total combined power (measured power levels are added over N antenna).

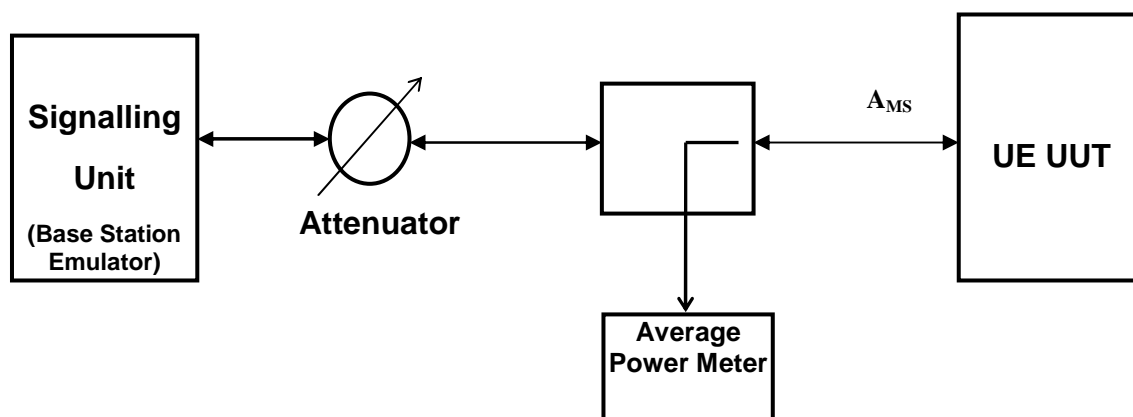

**Figure 5.4.1.1-1: Test Setup for UE maximum and minimum transmitter output power**

#### 5.4.1.1.1 Initial conditions

The UUT shall be configured to operate at the P<sub>nom</sub> level declared for the equipment under normal environmental conditions.

For a UUT with antenna connector(s) and using external antenna(s), or for a UUT with integral antenna(s) but with a temporary antenna connector provided, conducted measurements shall be used.

#### 5.4.1.1.2 Procedure

- Step 1 Set the RF channel to the lowest channel centre frequency from the declared range.
- Step 2 Ensure the data link connection has been established between UE UUT and Signalling Unit.
- Step 3 The UE UUT shall be configured to continuously transmit at the declared P<sub>nom</sub>.
- Step 4 Measure and note the measured power level for compliance with maximum output power in clause 4.2.2.
- Step 5 Configure the Signalling Unit to instruct the UE UUT to decrease the transmit power down to the point that the power can not be reduced further.
- Step 6 Measure and note the measured power level for compliance with minimum output power in clause 4.2.5.
- Step 7 Repeat steps 3 to 6 at the middle and highest RF channel centre frequencies from the declared range.
- Step 8 Repeat steps 2 to 7 for all modulation schemes supported by the UE UUT.
- Step 9 Repeat steps 1 to 8 under extreme environmental conditions TL/VL, TL/VH, TH/VL and TH/VH (see annex B).
- Step 10 End of test.

#### 5.4.1.2 Test requirements

For the UE UUT the maximum and minimum power levels recorded in the steps above for each of the RF channel centre frequencies and environmental conditions shall meet the requirements of clauses 4.2.2 and 4.2.5.

### 5.4.2 Transmitter Spectrum Emission Mask

The purpose of this test is to verify compliance of UE equipment to the transmitter spectrum emission mask requirements of clause 4.2.3.

### 5.4.2.1 Method of measurement

Figure 5.4.2.1-1 shows the test setup for testing the UE transmitter spectrum emission mask.

In the case that UE supports multiple transmit antenna (antenna 1 to N):

- 1) If single transmit antenna is a valid mode of operation, steps 1 to 7 below shall be performed on a selected single antenna port.
- 2) To test the mode with multiple antenna enabled:
  - a) Steps 1 to 7 below shall be repeated when all antenna are enabled (e.g. each antenna is transmitting at  $P_{nom} - 10\log_{10}(N)$  level).
  - b) Step 4 is modified to include total combined power (measured power levels are added over N antenna).

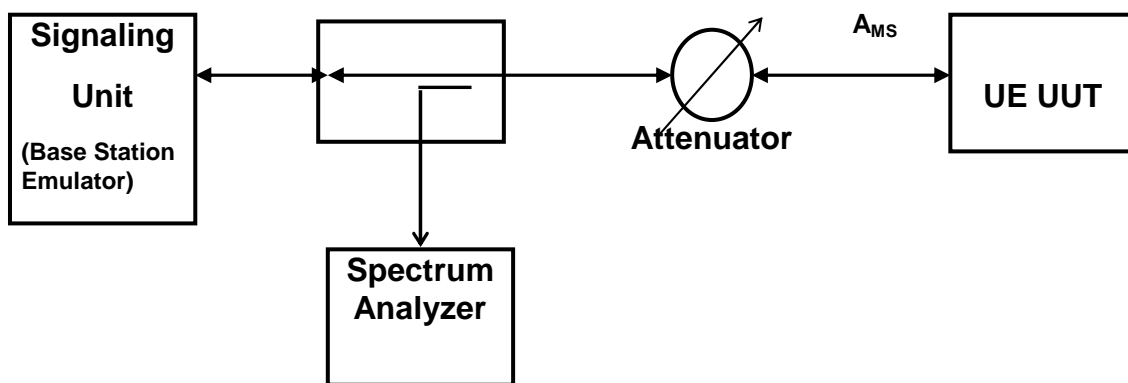

**Figure 5.4.2.1-1: Test Setup for UE transmitter spectrum emission mask measurement**

#### 5.4.2.1.1 Initial conditions

The UUT shall be configured to operate at the  $P_{nom}$  level declared for the equipment.

For a UUT with antenna connector(s) and using external antenna(s), or for a UUT with integral antenna(s) but with a temporary antenna connector provided, conducted measurements shall be used.

For systems implementing dynamic change of the modulation order; this test shall be modified and executed accordingly to accurately capture transient behaviour. For example, if a system automatically operates at higher output power when lower order modulations are used, the test must correctly capture this effect. There may be a need for manufacturers to include information to identify the correct test conditions. The equipment shall be configured to operate with continuous modulation mode switching at the maximum switching speed permitted by the system, with equal duty cycle for all modulation orders, and with all training bursts or reference signals active as in normal operation.

#### 5.4.2.1.2 Procedure

- Step 1 Set the RF channel to the lowest channel centre frequency from the declared range.
- Step 2 Ensure the data link connection has been established between UE UUT and Signalling Unit.
- Step 3 The spectrum analyzer must be correctly configured to measure the spectral mask. To avoid having the spectrum analyzer average the spectrum during periods when there is no transmission occurring, it is important to use a gated trigger mode. The gated trigger should be set up so that the spectrum analyzer is only triggered when the UUT is transmitting. Some spectrum analyzers can be configured for a gated trigger using the RF burst directly. However, other spectrum analyzers will require an independent gate signal, and this signal must be derived from the Signalling Unit. It is therefore recommended that the Signalling Unit provides a frame trigger signal.

Measurements should only be conducted during the transmission period.

- Step 4 Measure and note the signal spectrum over the range specified in clause 4.2.3.2 in accordance with the specified measurement bandwidths in the tables. Note that measurement aggregation is needed to compare with specified numbers according to the 1 MHz measurement bandwidth in the tables.
- Step 5 Repeat steps 3 and 4 at the middle and highest RF channel centre frequencies from the declared range.
- Step 6 Repeat steps 2 to 5 for all modulation schemes supported by the equipment under test.
- Step 7 End of test.

### 5.4.2.2 Test requirements

For the UE UUT the signal spectrum recorded in the steps above for each of the RF channel centre frequencies shall meet the requirements of clause 4.2.3 for the appropriate channel bandwidth supported.

## 5.4.3 Transmitter spurious emissions

The purpose of this test is to verify compliance of UE equipment to the transmitter spurious emission requirements of clause 4.2.4.

### 5.4.3.1 Method of measurement

Figure 5.4.3.1-1 shows the test setup for testing the UE transmitter spurious emission requirement.

In the case that UE supports multiple transmit antenna (antenna 1 to N):

- 1) If single transmit antenna is a valid mode of operation, steps 1 to 6 below shall be performed on a selected single antenna port.
- 2) To test the mode with multiple antenna enabled:
  - a) Steps 1 to 7 below shall be repeated when all antenna are enabled (e.g. each antenna is transmitting at  $P_{nom} - 10\log_{10}(N)$  level).
  - b) Step 4 is modified to include total combined power (measured power levels are added over N antenna).

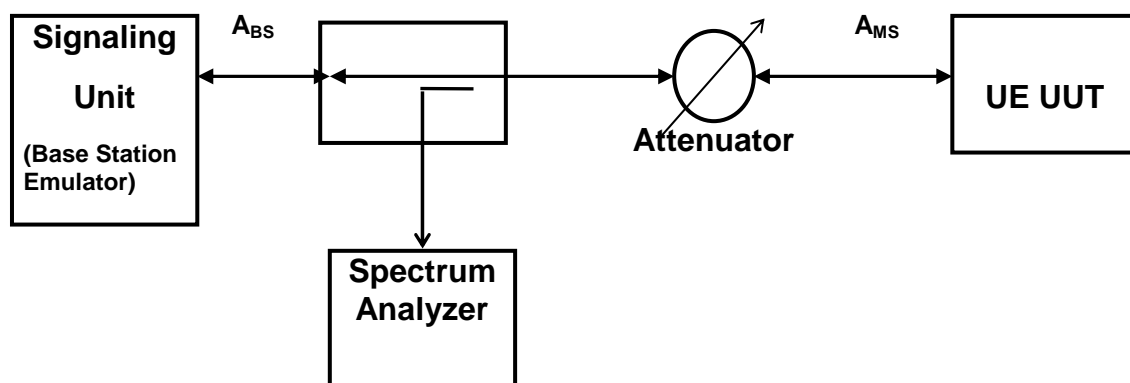

Figure 5.4.3.1-1: Test Setup for UE transmitter spurious emission measurement

#### 5.4.3.1.1 Initial conditions

The UUT shall be configured to operate at the  $P_{nom}$  level declared for the equipment.

For a UUT with antenna connector(s) and using external antenna(s), or for a UUT with integral antenna(s) but with a temporary antenna connector provided, conducted measurements shall be used.

In the spectrum analyzer, set the measurement bandwidth as specified in the relevant table of clause 4.2.4. Set the video bandwidth to a value of three times the measurement bandwidth. True RMS detector shall be used.

For systems implementing dynamic change of the modulation order, the equipment shall be configured to operate with continuous modulation mode switching at the maximum switching speed permitted by the system, with equal duty cycle for all modulation orders, and with all training bursts or reference signals active as in normal operation.

#### 5.4.3.1.2 Procedure

- Step 1 Set the RF channel at lowest channel centre frequency from the declared range.
- Step 2 Ensure the data link connection has been established between UE UUT and Signalling Unit.
- Step 3 The UE UUT is configured to transmit at its  $P_{nom}$  output power.
- Step 4 Measure and note the UE transmitter spurious emissions over the frequency range and within the specified measurement bandwidth specified in the relevant table of clause 4.2.4.
- Step 5 Repeat steps 2 to 4 at the middle and highest RF channel centre frequencies from the declared range.
- Step 6 End of test.

#### 5.4.3.2 Test requirements

For the UE UUT the transmitter spurious emission levels recorded in the steps above for each of the RF channel centre frequencies shall meet the requirements of clause 4.2.4.

### 5.4.4 Receiver Adjacent Channel Selectivity (ACS)

The purpose of this test is to verify compliance of UE equipment to the receiver adjacent channel selectivity requirements of clause 4.2.6.

#### 5.4.4.1 Method of measurement

The interfering source shall be a conforming unsynchronized signal with the same signalling technology as the in-channel signal.

In the case that the UE supports multiple receive antennas (antenna 1 to N), a single channel is connected to the multiple antenna ports through a splitter. In this case, the test system is calibrated to the antenna ports to take into account splitter losses and identical signals and power levels ( $\pm 0,3$  dB) are applied to each antenna port.

Figure 5.4.4.1-1 shows the test setup for testing the UE receiver adjacent channel selectivity.

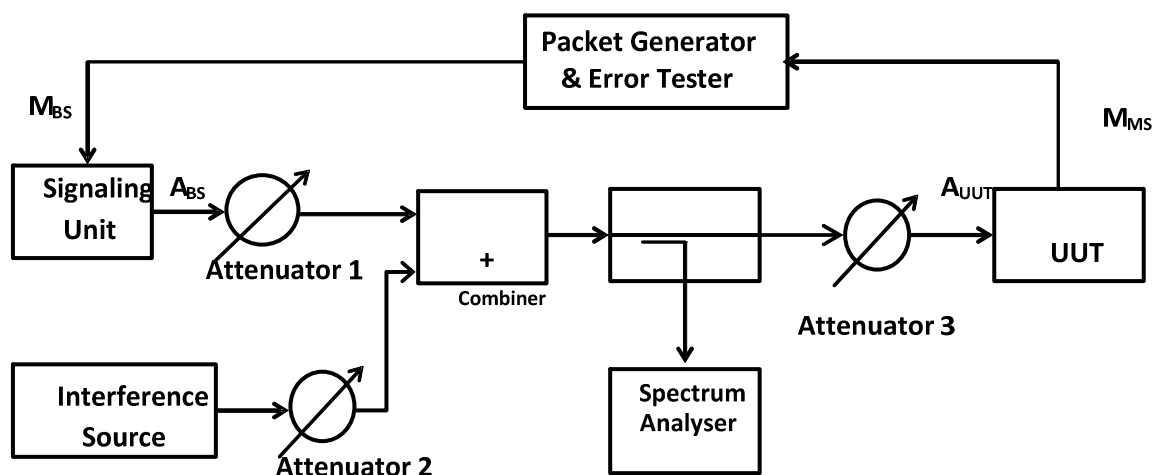

Figure 5.4.4.1-1: Test Setup for UE receiver adjacent channel selectivity measurement

#### 5.4.4.1.1 Initial conditions

Set the interfering source to the first adjacent channel operating frequency in accordance with table 4.2.6.2-1. Set the interfering signal source bandwidth to be the same as the in-channel operating bandwidth. Turn the interfering source off.

#### 5.4.4.1.2 Procedure

- Step 1 Set the UUT and signalling unit to the RF channel corresponding to the lowest channel centre frequency from the declared range.
- Step 2 Adjust the received signal level at  $A_{UUT}$  to be 3dB above the sensitivity level  $P_{SENS}$ . Note the signal level is measured over the time period of the data burst only within the downlink transmission.
- Step 3 Turn on the interfering source.
- Step 4 Increase the interfering source power to the appropriate adjacent channel power level identified in table 4.2.6.2-1.
- Step 5 Perform a BER measurement and record the results.
- Step 6 Turn the interference source off.
- Step 7 Set the interfering source to the second adjacent channel operating frequency. Repeat step 2 to step 6 above for the second adjacent channel test cases and record the results.
- Step 8 Reset the interfering source to the first adjacent channel operating frequency and repeat steps 2 to 7 at the middle and highest RF channel centre frequencies from the declared range.
- Step 9 End of test.

#### 5.4.4.2 Test requirements

For the UE UUT the worst case BER measurement recorded in steps above for each of the RF channel centre frequencies shall meet the requirements of clause 4.2.6.

### 5.4.5 Receiver Blocking Characteristics

The purpose of this test is to verify compliance of UE equipment to the receiver blocking characteristic requirements of clause 4.2.7.

#### 5.4.5.1 Method of measurement

The interfering source shall be a conforming unsynchronized signal with the same signalling technology as the in-channel signal.

In the case that the UE supports multiple receive antennas (antenna 1 to N), a single channel is connected to the multiple antenna ports through a splitter. In this case, the test system is calibrated to the antenna ports to take into account splitter losses and identical signals and power levels ( $\pm 0,3$  dB) are applied to each antenna port.

Figure 5.4.5.1-1 shows the test setup of the receiver blocking test.



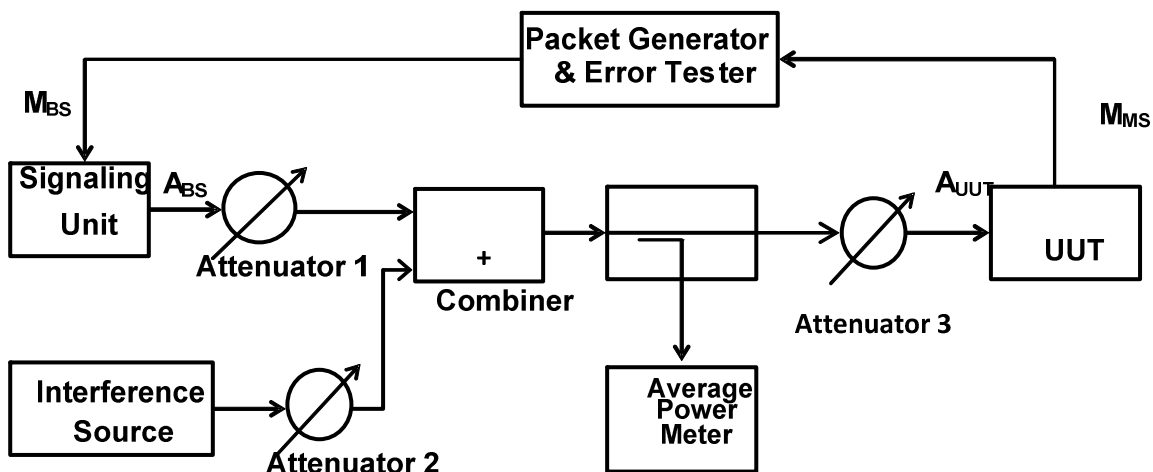

Figure 5.4.5.1-1: Test Setup for UE receiver blocking measurement

#### 5.4.5.1.1 Initial conditions

Set the interfering signal source bandwidth to be the same as the in-channel operating bandwidth and operating on an interfering source centre frequency in accordance with table 4.2.7.2-1 or 4.2.7.2-2 according to the system channel bandwidth under test. Set the interfering signal mean power to the level identified in table 4.2.7.2-1 or 4.2.7.2-2.

Turn the interfering source off.

#### 5.4.5.1.2 Procedure

- Step 1 Set the UUT and signalling unit to the RF channel corresponding to the lowest channel centre frequency from the declared range.
- Step 2 Adjust the received signal level at  $A_{UUT}$  to be 6 dB above the sensitivity level  $P_{SENS5}$  or  $P_{SENS10}$ . Note the signal level is measured over the time period of the data burst only within the downlink transmission.
- Step 3 Turn on the interfering source.
- Step 4 Step the interfering signal generator frequency through the frequency range indicated in table 4.2.7.2-1 or 4.2.7.2-2 according to the system channel bandwidth under test, with a step size of 1 MHz.
- Step 5 Measure the BER of the desired signal received for each step of the interfering frequency and record the results.
- Step 6 Record any interfering signal centre frequency at which the blocking requirement is not met.
- Step 7 Turn the interference source off.
- Step 8 Repeat the test procedure at middle and highest channel centre frequencies for the desired received signal from the declared range.
- Step 9 End of test.

#### 5.4.5.2 Test requirements

For the UE UUT the worst case BER measurement recorded in the steps above for each step of the interfering signal and at each of the RF channel centre frequencies shall meet the requirements of clause 4.2.7.

## 5.4.6 Receiver Spurious Response

The purpose of this test is to verify compliance of UE equipment to the receiver spurious response requirements of clause 4.2.8.

### 5.4.6.1 Method of measurement

The interfering source shall consist of a CW signal. Test frequencies for the desired signal and CW interferer shall be defined from those exceptions declared during execution of the receiver blocking test.

In the case that the UE supports multiple receive antennas (antenna 1 to N), a single channel is connected to the multiple antenna ports through a splitter. In this case, the test system is calibrated to the antenna ports to take into account splitter losses and identical signals and power levels ( $\pm 0,3$  dB) are applied to each antenna port.

Figure 5.4.6.1-1 shows the test setup for the receiver spurious response test.

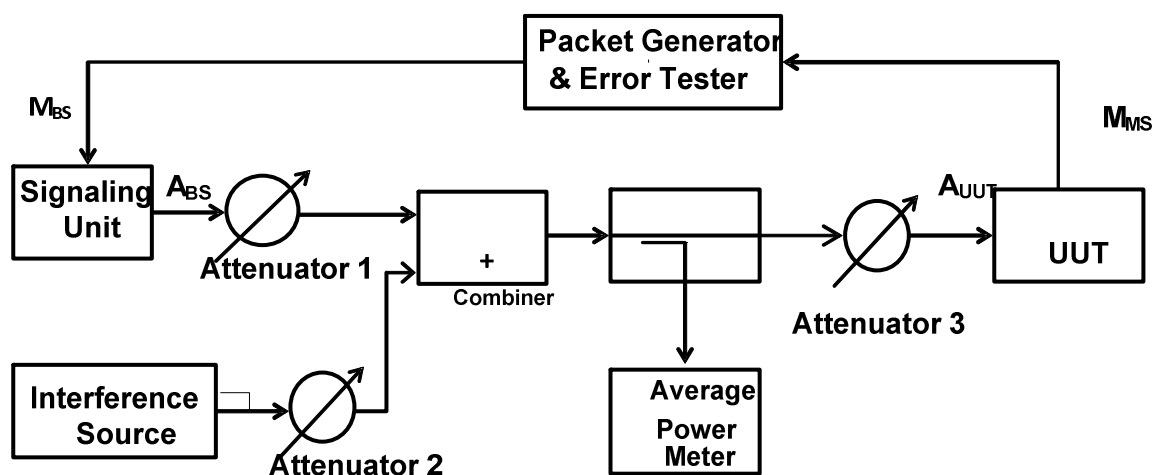

Figure 5.4.6.1-1: Test setup for receiver spurious response test

#### 5.4.6.1.1 Initial conditions

Set the desired received signal BW to the signal BW used in the receiver blocking test, as described in clause 5.4.5.1 at which the blocking test failed.

#### 5.4.6.1.2 Procedure

- Step 1 Set the desired received signal frequency to the frequency used for the receiver blocking test, as described in clause 5.4.8.1.1 at which the blocking test requirements were not met.
- Step 2 Adjust the received signal level at  $A_{UUT}$  to be 6 dB above the sensitivity level  $P_{SENS5}$  or  $P_{SENS10}$  according to the channel bandwidth under test. Note the signal level is measured over the time period of the data burst only within the downlink transmission.
- Step 3 Set the frequency of the interferer signal according the recorded spurious response frequency values obtained from the blocking test as described in clause 5.4.5.1.2 step 6 at which the blocking test requirements were not met.
- Step 4 Set the power level of the interferer according to either table 4.2.8.2-1 or 4.2.8.2-2 as appropriate.
- Step 5 Measure the BER of the desired signal received for each frequency of the interferer signal and record the results.
- Step 6 Repeat the test procedure at all frequencies which the blocking test requirements were not met.
- Step 7 End of test.

### 5.4.6.2 Test requirements

For the UE UUT the worst case BER measurement recorded in the steps above for each of the interfering signals shall meet the requirements of clause 4.2.8.

## 5.4.7 Receiver Intermodulation characteristics

The purpose of this test is to verify compliance of UE equipment to the receiver intermodulation characteristic requirements of clause 4.2.9.

### 5.4.7.1 Method of measurement

Interfering sources shall consist of a CW signal and a conforming unsynchronized signal with the same signalling technology as the in-channel signal.

In the case that the UE supports multiple receive antennas (antenna 1 to N), a single channel is connected to the multiple antenna ports through a splitter. In this case, the test system is calibrated to the antenna ports to take into account splitter losses and identical signals and power levels ( $\pm 0,3$  dB) are applied to each antenna port.

Figure 5.4.7.1-1 shows the test setup for the receiver intermodulation test.

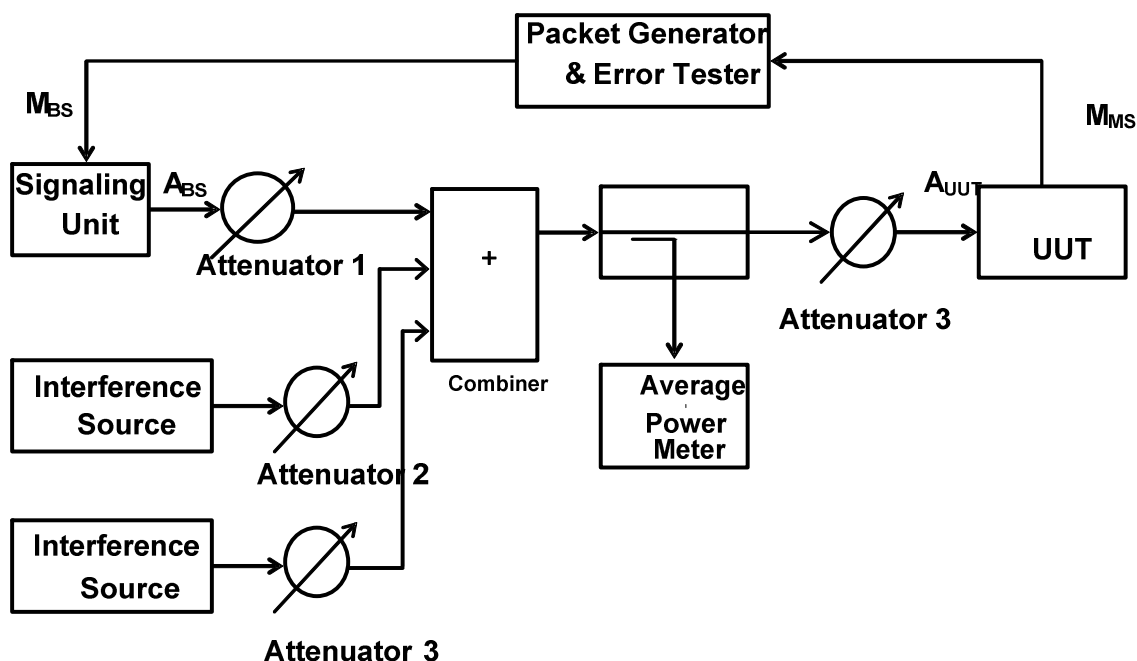

Figure 5.4.7.1-1: Test setup for receiver intermodulation response test

#### 5.4.7.1.1 Initial conditions

Set the modulated interfering signal source bandwidth to be the same as the in-channel operating bandwidth. Set the interfering source centre frequency to have a positive frequency offset from the upper wanted channel edge in accordance with table 4.2.9.2-1 or 4.2.9.2-2 according to the system channel bandwidth under test. Set the modulated interfering signal mean power to the level identified in table 4.2.9.2-1 or 4.2.9.2-2 according to the system channel bandwidth under test.

Set the CW interfering signal frequency to have a positive frequency offset from the upper wanted channel edge in accordance with table 4.2.9.2-1 or 4.2.9.2-2 according to the system channel bandwidth under test. Set the CW interfering signal mean power to the level identified in table 4.2.9.2-1 or 4.2.9.2-2 according to the system channel bandwidth under test. Turn the interfering sources off.

### 5.4.7.1.2 Procedure

- Step 1 Set the UUT and signalling unit to the RF channel corresponding to the lowest channel centre frequency from the declared range.
- Step 2 Adjust the received signal level at  $A_{UUT}$  to be 6 dB above the sensitivity level  $P_{SENS} + 6$  dB. Note the signal level is measured over the time period of the data burst only within the downlink transmission.
- Step 3 Turn on the interfering sources.
- Step 4 Measure the BER of the desired signal received and record the results.
- Step 5 Turn the interfering sources off.
- Step 6 Reconfigure the interfering sources to transmit with negative frequency offsets from the lower wanted channel edge as defined in table 4.2.9.2-1 or 4.2.9.2-2 according to the system channel bandwidth under test.
- Step 7 Turn on the interfering sources.
- Step 8 Measure the BER of the desired signal received and record the results.
- Step 9 Turn the interfering sources off.
- Step 10 Repeat the test procedure at middle and highest channel centre frequencies for the desired received signal from the declared range.
- Step 11 End of test.

### 5.4.7.2 Test requirements

For the UE UUT the worst case BER measurement recorded in the steps above for each of the RF channel centre frequencies shall meet the requirements of clause 4.2.9.

## 5.4.8 Receiver Spurious Emissions

The purpose of this test is to verify compliance of UE equipment to the receiver spurious emission requirements of clause 4.2.10.

### 5.4.8.1 Method of measurement

Figure 5.4.8.1-1 shows the test setup for testing the UE transmitter spurious emission requirement.

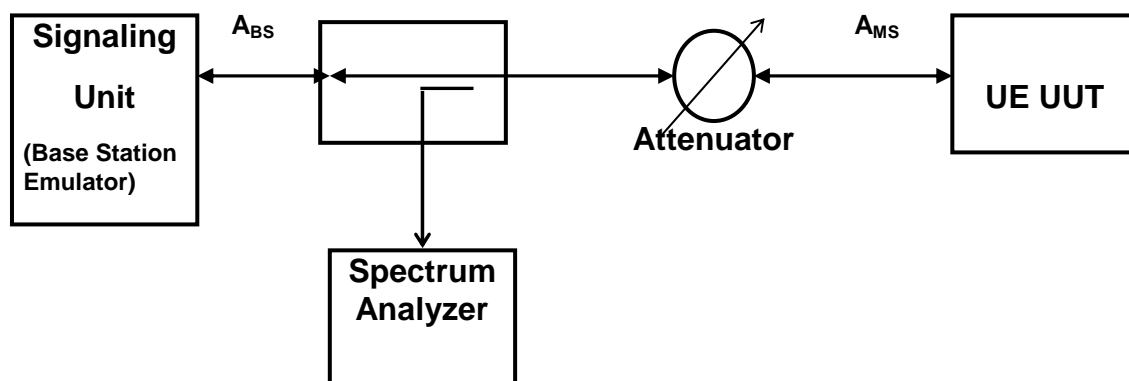

Figure 5.4.8.1-1: Test Setup for UE receiver spurious emission measurement

#### 5.4.8.1.1 Initial conditions

For a UUT with antenna connector(s) and using external antenna(s), or for a UUT with integral antenna(s) but with a temporary antenna connector provided, conducted measurements shall be used.

In the spectrum analyzer, set the measurement bandwidth as specified in the relevant table of clause 4.2.10. Set the video bandwidth to a value of three times the measurement bandwidth. True RMS detector shall be used.

#### 5.4.8.1.2 Procedure

- |        |  |
|--------|--|
| Step 1 | Set the UUT to the RF channel corresponding to the lowest channel centre frequency from the declared range.  |
| Step 2 | Ensure the data link connection has been established between UE UUT and Signalling Unit.   |
| Step 3 | The UE UUT is configured to transmit at its P <sub>nom</sub> output power as measured over the 5 MHz or 10 MHz of allocated bandwidth.   |
| Step 4 | Measure and note the UE receiver spurious emissions over the range specified in clause 4.2.10 according to the specified measurement bandwidths in the table. The receiver spurious emission measurements should be only taken during the receive part of the TDD frame. |
| Step 5 | Repeat steps 2 to 4 at middle and highest RF channel centre frequencies from the declared range.   |
| Step 6 | End of test.   |

#### 5.4.8.2 Test requirements

For the UE UUT the measured receiver spurious emission levels recorded in the steps above for each of the RF channel centre frequencies shall meet the requirements of clause 4.2.10.

### 5.4.9 Transmitter Adjacent Channel Leakage Power Ratio

The purpose of this test is to verify compliance of UE equipment to the transmitter adjacent channel leakage power ratio requirements of clause 4.2.11.

#### 5.4.9.1 Method of measurement

Figure 5.4.9.1-1 shows the test setup for testing the UE transmitter adjacent channel leakage ratio.

In the case that UE supports multiple transmit antenna (antenna 1 to N):

- 1) If single transmit antenna is a valid mode of operation, steps 1 to 7 below shall be performed on a selected single antenna port.
- 2) To test the mode with multiple antenna enabled:
  - a) Steps 1 to 7 below shall be repeated when all antenna are enabled (e.g. each antenna is transmitting at P<sub>nom</sub> - 10log<sub>10</sub>(N) level).
  - b) Step 4 is modified to include total combined power (measured power levels are added over N antenna).

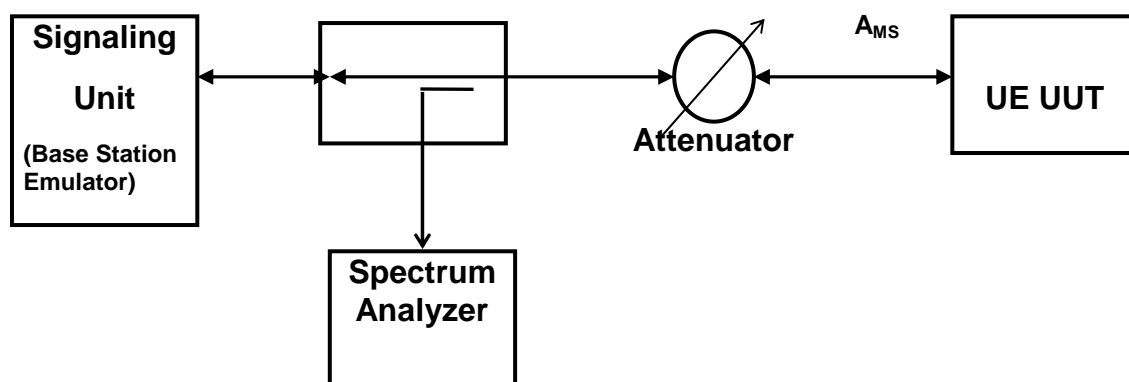

**Figure 5.4.9.1-1: Test Setup for UE transmitter adjacent channel leakage ratio measurement**

#### 5.4.9.1.1 Initial conditions

The UUT shall be configured to operate at the P<sub>nom</sub> level declared for the equipment under normal environmental conditions.

For a UUT with antenna connector(s) and using external antenna(s), or for a UUT with integral antenna(s) but with a temporary antenna connector provided, conducted measurements shall be used.

For systems implementing dynamic change of the modulation order; this test shall be modified and executed accordingly to accurately capture transient behaviour. For example, if a system automatically operates at higher output power when lower order modulations are used, the test must correctly capture this effect. There may be a need for manufacturers to include information to identify the correct test conditions. The equipment shall be configured to operate with continuous modulation mode switching at the maximum switching speed permitted by the system, with equal duty cycle for all modulation orders, and with all training bursts or reference signals active as in normal operation.

#### 5.4.9.1.2 Procedure

- Step 1 Set the RF channel to the lowest channel centre frequency from the declared range.
- Step 2 Ensure the data link connection has been established between UE UUT and Signalling Unit.
- Step 3 The spectrum analyzer must be correctly configured to measure the aggregated power. To avoid having the spectrum analyzer average the spectrum during periods when there is no transmission occurring (such as a DL burst), it is important to use a gated trigger mode. The gated trigger should be set up so that the spectrum analyzer is only triggered when the UUT is transmitting. Some spectrum analyzers can be configured for a gated trigger using the RF burst directly. However, other spectrum analyzers will require an independent gate signal, and this signal must be derived from the Base Station Emulator (BSE). It is therefore recommended that the BSE provide a frame trigger signal.  
  
Measurements should only be conducted during the transmission.
- Step 4 Measure the aggregated power measured over a frequency range equal to 4,75 MHz and 9,5 MHz (for 5 MHz and 10 MHz cases respectively) centred on the assigned channel frequency.
- Step 5 Average over a sufficient number of transmitted bursts to obtain a stable reading.
- Step 6 Measure the aggregated power measured over a frequency range equal to 4,75 MHz and 9,5 MHz (for 5 MHz and 10 MHz cases respectively) centred on the first lower adjacent channel frequency which is 5 MHz (10 MHz for 10 MHz channel bandwidth) apart from operating RF channel centre frequency.
- Step 7 Average over a sufficient number of transmitted bursts to obtain a stable reading.
- Step 8 Calculate the ACLR by: (Power according to step 5)/(Power according to step 7).

- Step 9 Repeat steps 4 to 8 for the second adjacent (lower) RF channel (centre frequency 10 MHz for the 5 MHz channel bandwidth and 20 MHz for 10 MHz channel bandwidth, respectively, below the assigned channel frequency of the transmitted signal) and also for the first and second upper adjacent RF channel.
- Step 10 Run steps 2 to 9 at the middle and highest RF channel centre frequencies from the declared range.
- Step 11 Repeat steps 1 to 10 under extreme environmental conditions TL/VL, TL/VH, TH/VL and TH/VH (see annex B).
- Step 12 End of test.

#### 5.4.9.2 Test requirements

For the UE UUT the maximum power levels recorded in the steps above and the ACLR calculation for each of the RF channel centre frequencies and environmental conditions shall meet the requirements of clause 4.2.11.

## Annex A (normative): HS Requirements and conformance Test specifications Table (HS-RTT)

The HS Requirements and conformance Test specifications Table (HS-RTT) in table A-1 serves a number of purposes, as follows:

- it provides a statement of all the requirements in words and by cross reference to (a) specific clause(s) in the present document or to (a) specific clause(s) in (a) specific referenced document(s);
- it provides a statement of all the test procedures corresponding to those requirements by cross reference to (a) specific clause(s) in the present document or to (a) specific clause(s) in (a) specific referenced document(s);
- it qualifies each requirement to be either:
  - Unconditional: meaning that the requirement applies in all circumstances; or
  - Conditional: meaning that the requirement is dependent on the manufacturer having chosen to support optional functionality defined within the schedule;
- in the case of Conditional requirements, it associates the requirement with the particular optional service or functionality;
- it qualifies each test procedure to be either:
  - Essential: meaning that it is included with the Essential Radio Test Suite and therefore the requirement shall be demonstrated to be met in accordance with the referenced procedures;
  - Other: meaning that the test procedure is illustrative but other means of demonstrating compliance with the requirement are permitted.

**Table A-1: HS Requirements and conformance Test specifications Table (HS-RTT)**

<b>Harmonized Standard EN 301 908-19</b>						
The following requirements and test specifications are relevant to the presumption of conformity under article 3.2 of the R&TTE Directive [i.2]						
<b>Requirement</b>			<b>Requirement Conditionality</b>		<b>Test Specification</b>	
<b>No</b>	<b>Description</b>	<b>Reference: Clause No</b>	<b>U/C</b>	<b>Condition</b>	<b>E/O</b>	<b>Reference: Clause No</b>
1	Transmitter Maximum Output Power	4.2.2	U		E	5.4.1
2	Transmitter Spectrum Emission Mask	4.2.3	U		E	5.4.2
3	Transmitter Spurious Emissions	4.2.4	U		E	5.4.3
4	Transmitter Minimum Output Power	4.2.5	U		E	5.4.1
5	Receiver Adjacent Channel Selectivity (ACS)	4.2.6	U		E	5.4.4
6	Receiver Blocking Characteristics	4.2.7	U		E	5.4.5
7	Receiver Spurious Response	4.2.8	U		E	5.4.6
8	Receiver Intermodulation Characteristics	4.2.9	U		E	5.4.7
9	Receiver Spurious Emissions	4.2.10	U		E	5.4.8
10	Transmitter Adjacent Channel Leakage Power Ratio	4.2.11	U		E	5.4.9



**Key to columns:****Requirement:**

**No** A unique identifier for one row of the table which may be used to identify a requirement or its test specification.

**Description** A textual reference to the requirement.

**Clause Number** Identification of clause(s) defining the requirement in the present document unless another document is referenced explicitly.

**Requirement Conditionality:**

**U/C** Indicates whether the requirement is to be *unconditionally* applicable (U) or is *conditional* upon the manufacturers claimed functionality of the equipment (C).

**Condition** Explains the conditions when the requirement shall or shall not be applicable for a technical requirement which is classified "conditional".

**Test Specification:**

**E/O** Indicates whether the test specification forms part of the Essential Radio Test Suite (E) or whether it is one of the Other Test Suite (O).

**NOTE:** All tests whether "E" or "O" are relevant to the requirements. Rows designated "E" collectively make up the Essential Radio Test Suite; those designated "O" make up the Other Test Suite; for those designated "X" there is no test specified corresponding to the requirement. The completion of all tests classified "E" as specified with satisfactory outcomes is a necessary condition for a presumption of conformity. Compliance with requirements associated with tests classified "O" or "X" is a necessary condition for presumption of conformity, although conformance with the requirement may be claimed by an equivalent test or by manufacturer's assertion supported by appropriate entries in the technical construction file.

**Clause Number** Identification of clause(s) defining the test specification in the present document unless another document is referenced explicitly. Where no test is specified (that is, where the previous field is "X") this field remains blank.

---

## Annex B (normative): Environmental profile

The following environmental conditions may be declared by the manufacturer:

- barometric pressure: minimum and maximum;
- temperature: normal and minimum/maximum extremes;
- relative humidity: maximum;
- power supply: normal and lower/upper voltage extremes.

Where an extreme environment is required then the various combinations of extreme temperatures together with the extreme voltages are shown below:

- low extreme Temperature/Low extreme Voltage (TL/VL);
- low extreme Temperature/High extreme Voltage (TL/VH);
- high extreme Temperature/Low extreme Voltage (TH/VL);
- high extreme Temperature/High extreme Voltage (TH/VH).

---

## Annex C (informative): The EN title in the official languages

The enlargement of the European Union (EU) resulted in a requirement from the EU for a larger number of languages for the translation of the titles of Harmonized Standards and mandated ENs that are to be listed in the Official Journal to support the implementation of this legislation.

For this reason the title translation concerning the present document can be consulted via the [e-approval](#) application.

---

## Annex D (informative): Bibliography

- Directive 2004/108/EC of the European Parliament and of the Council of 15 December 2004 on the approximation of the laws of the Member States relating to electromagnetic compatibility and repealing Directive 89/336/EEC (EMC Directive).
- Directive 2006/95/EC of the European Parliament and of the Council of 12 December 2006 on the harmonisation of the laws of Member States relating to electrical equipment designed for use within certain voltage limits (LV Directive).
- WiMAX Forum® Air Interface specifications; WiMAX Forum® Mobile Radio Specification: WMF-T23-005-R015v05.

---

## History

<b>Document history</b>		
V5.1.1	February 2011	Public Enquiry PE 20110607: 2011-02-07 to 2011-06-07
V5.2.1	July 2011	Vote V 20110911: 2011-07-13 to 2011-09-12
V5.2.1	September 2011	Publication