

ETSI EN 301 908-18 V15.1.1 (2021-09)



**IMT cellular networks;
Harmonised Standard for access to radio spectrum;
Part 18: E-UTRA, UTRA and GSM/EDGE
Multi-Standard Radio (MSR) Base Station (BS)
Release 15**

ReferenceREN/MSG-TFES-15-18

Keywords3G, 3GPP, 5G, cellular, digital, EDGE, E-UTRA,
GSM, IMT, IMT-2000, IMT-Advanced, LTE, mobile,
MSR, NR, radio, regulation, UMTS, UTRA,
WCDMA**ETSI**650 Route des Lucioles
F-06921 Sophia Antipolis Cedex - FRANCE

Tel.: +33 4 92 94 42 00 Fax: +33 4 93 65 47 16

Siret N° 348 623 562 00017 - APE 7112B
Association à but non lucratif enregistrée à la
Sous-Préfecture de Grasse (06) N° w061004871

Important notice

The present document can be downloaded from:

<http://www.etsi.org/standards-search>

The present document may be made available in electronic versions and/or in print. The content of any electronic and/or print versions of the present document shall not be modified without the prior written authorization of ETSI. In case of any existing or perceived difference in contents between such versions and/or in print, the prevailing version of an ETSI deliverable is the one made publicly available in PDF format at www.etsi.org/deliver.

Users of the present document should be aware that the document may be subject to revision or change of status.

Information on the current status of this and other ETSI documents is available at

<https://portal.etsi.org/TB/ETSIDeliverableStatus.aspx>

If you find errors in the present document, please send your comment to one of the following services:

<https://portal.etsi.org/People/CommitteeSupportStaff.aspx>

Notice of disclaimer & limitation of liability

The information provided in the present deliverable is directed solely to professionals who have the appropriate degree of experience to understand and interpret its content in accordance with generally accepted engineering or other professional standard and applicable regulations.

No recommendation as to products and services or vendors is made or should be implied.

In no event shall ETSI be held liable for loss of profits or any other incidental or consequential damages.

Any software contained in this deliverable is provided "AS IS" with no warranties, express or implied, including but not limited to, the warranties of merchantability, fitness for a particular purpose and non-infringement of intellectual property rights and ETSI shall not be held liable in any event for any damages whatsoever (including, without limitation, damages for loss of profits, business interruption, loss of information, or any other pecuniary loss) arising out of or related to the use of or inability to use the software.

Copyright Notification

No part may be reproduced or utilized in any form or by any means, electronic or mechanical, including photocopying and microfilm except as authorized by written permission of ETSI.

The content of the PDF version shall not be modified without the written authorization of ETSI.

The copyright and the foregoing restriction extend to reproduction in all media.

© ETSI 2021.
All rights reserved.

Contents

Intellectual Property Rights	7
Foreword.....	7
Modal verbs terminology.....	8
Introduction	8
1 Scope	9
2 References	11
2.1 Normative references	11
2.2 Informative references.....	12
3 Definition of terms, symbols and abbreviations.....	14
3.1 Terms.....	14
3.2 Symbols.....	16
3.3 Abbreviations	17
4 Technical requirements specifications	19
4.1 Environmental profile.....	19
4.2 Conformance requirements	19
4.2.1 Introduction.....	19
4.2.2 Operating band unwanted emissions	21
4.2.2.1 Definition	21
4.2.2.2 Limits	21
4.2.2.2.1 Limits for Band Categories 1 and 3.....	21
4.2.2.2.2 Limits for Band Category 2.....	32
4.2.2.2.3 Limits for GSM/EDGE single-RAT operation.....	40
4.2.2.2.4 Void.....	40
4.2.2.2.5 Void.....	40
4.2.2.2.6 Void.....	40
4.2.2.2.7 Additional limits for operation in bands in 50 and 75 within 1 432 to 1 452 MHz, and in bands 51 and 76.....	40
4.2.2.2.8 Additional limits for operation in band 43 for co-existence with FSS/FS	41
4.2.2.3 Conformance.....	41
4.2.3 Adjacent Channel Leakage power Ratio (ACLR)	41
4.2.3.1 Definition	41
4.2.3.2 Limits	41
4.2.3.2.1 E-UTRA limits	41
4.2.3.2.2 UTRA FDD limits	43
4.2.3.2.3 UTRA TDD limits.....	43
4.2.3.2.4 Cumulative ACLR requirement in non-contiguous spectrum	43
4.2.3.2.5 NB-IoT test requirement.....	45
4.2.3.2.6 NR test requirement.....	45
4.2.3.3 Conformance.....	46
4.2.4 Transmitter spurious emissions.....	47
4.2.4.1 Definition	47
4.2.4.2 Limits	47
4.2.4.2.1 Spurious emissions	47
4.2.4.2.2 Additional spurious emissions requirement for BC2.....	47
4.2.4.2.3 Co-existence with other systems	48
4.2.4.2.4 Protection of the BS receiver of own or different BS	50
4.2.4.3 Conformance.....	51
4.2.5 Base station maximum output power.....	51
4.2.5.1 Definition	51
4.2.5.2 Limits	51
4.2.5.3 Conformance.....	51
4.2.6 Transmit intermodulation	52
4.2.6.1 Definition	52
4.2.6.2 Limits	52

4.2.6.2.1	General limits	52
4.2.6.2.2	Additional limits (BC1 and BC2)	52
4.2.6.2.3	Additional limits (BC3)	53
4.2.6.3	Conformance	53
4.2.7	Receiver spurious emissions	54
4.2.7.1	Definition	54
4.2.7.2	Limits	54
4.2.7.2.1	General limits	54
4.2.7.2.2	Additional limits for BC2	54
4.2.7.3	Conformance	55
4.2.8	In-band blocking	55
4.2.8.1	Definition	55
4.2.8.2	Limits	55
4.2.8.2.1	General limits	55
4.2.8.2.2	Additional BC3 blocking limits	57
4.2.8.3	Conformance	57
4.2.9	Out-of-band blocking	57
4.2.9.1	Definition	57
4.2.9.2	Limits	57
4.2.9.3	Conformance	58
4.2.10	Receiver intermodulation characteristics	58
4.2.10.1	Definition	58
4.2.10.2	Limits	59
4.2.10.2.1	General intermodulation limits	59
4.2.10.2.2	General narrowband intermodulation limits	60
4.2.10.2.3	Additional narrowband intermodulation limits for GSM/EDGE	63
4.2.10.3	Conformance	63
4.2.11	Narrowband blocking	63
4.2.11.1	Definition	63
4.2.11.2	Limits	63
4.2.11.2.1	General limits	63
4.2.11.2.2	Additional limits for GSM/EDGE	65
4.2.11.2.3	GSM/EDGE limits for AM suppression	65
4.2.11.3	Conformance	65
4.2.12	Reference sensitivity level	65
4.2.12.1	Definition	65
4.2.12.2	Limits	65
4.2.12.3	Conformance	66
5	Testing for compliance with technical requirements	66
5.1	Environmental conditions for testing	66
5.2	Void	66
5.3	Essential radio test suites	66
5.3.0	Introduction	66
5.3.1	Operating band unwanted emissions	67
5.3.1.0	General	67
5.3.1.1	Initial conditions	67
5.3.1.2	Procedure	67
5.3.1.3	Test requirement	68
5.3.2	Adjacent Channel Leakage power Ratio (ACLR)	68
5.3.2.0	General	68
5.3.2.1	Initial conditions	68
5.3.2.2	Procedure	68
5.3.2.3	Test requirement	69
5.3.3	Transmitter spurious emissions	69
5.3.3.1	Initial conditions	69
5.3.3.2	Procedure	69
5.3.3.3	Test requirement	70
5.3.4	Base station maximum output power	70
5.3.4.1	Initial conditions	70
5.3.4.2	Procedure	70
5.3.4.3	Test requirement	70

5.3.5	Transmit intermodulation	70
5.3.5.0	General	70
5.3.5.1	Initial conditions	71
5.3.5.2	Procedure	71
5.3.5.2.1	General minimum requirement test procedure	71
5.3.5.2.2	Additional minimum requirement (BC1 and BC2) test procedure	72
5.3.5.2.3	Additional minimum requirement (BC3) test procedure	73
5.3.5.3	Test requirement	73
5.3.6	Receiver spurious emissions	73
5.3.6.1	Initial conditions	73
5.3.6.2	Procedure	74
5.3.6.3	Test requirement	74
5.3.7	In-band blocking	74
5.3.7.1	Initial conditions	74
5.3.7.2	Procedure	74
5.3.7.2.1	Procedure for general blocking	74
5.3.7.2.2	Procedure for additional BC3 blocking requirement	75
5.3.7.3	Test requirement	75
5.3.8	Out-of-band blocking	75
5.3.8.1	Initial conditions	75
5.3.8.2	Procedure	76
5.3.8.3	Test requirement	76
5.3.9	Receiver intermodulation characteristics	76
5.3.9.1	Initial conditions	76
5.3.9.2	Procedure	77
5.3.9.2.1	Procedure for general and narrowband intermodulation	77
5.3.9.2.2	Procedure for additional narrowband intermodulation for GSM/EDGE	77
5.3.9.3	Test requirement	78
5.3.10	Narrowband blocking	78
5.3.10.1	Initial conditions	78
5.3.10.2	Procedure	78
5.3.10.2.1	Procedure for narrowband blocking	78
5.3.10.2.2	Procedure for additional narrowband blocking for GSM/EDGE	79
5.3.10.2.3	Procedure for GSM/EDGE AM suppression	79
5.3.10.3	Test requirement	80
5.3.11	Reference sensitivity level	80
5.3.11.1	General	80
5.3.11.1A	Initial conditions for GSM/EDGE reference sensitivity level for CS7 and CS15	81
5.3.11.1B	Procedure for GSM/EDGE reference sensitivity level for CS7 and CS15	81
5.3.11.2	Test requirement	81

Annex A (informative):	Relationship between the present document and the essential requirements of Directive 2014/53/EU	82
-------------------------------	---	-----------

Annex B (normative):	Base Station configurations.....	84
-----------------------------	---	-----------

B.1	Reception with multiple receiver antenna connectors and receiver diversity	84
B.2	Duplexers	84
B.3	Power supply options	84
B.4	Ancillary RF amplifiers.....	84
B.5	BS using antenna arrays	85
B.5.0	General	85
B.5.1	Receiver tests.....	85
B.5.2	Transmitter tests	86
B.6	Transmission with multiple transmitter antenna connectors	86
B.7	BS with integrated Iuant BS modem	86

Annex C (informative):	Maximum measurement uncertainty	87
-------------------------------	--	-----------

Annex D (informative):	Bibliography.....	89
Annex E (informative):	Change history	90
History		91

Intellectual Property Rights

Essential patents

IPRs essential or potentially essential to normative deliverables may have been declared to ETSI. The declarations pertaining to these essential IPRs, if any, are publicly available for **ETSI members and non-members**, and can be found in ETSI SR 000 314: "*Intellectual Property Rights (IPRs); Essential, or potentially Essential, IPRs notified to ETSI in respect of ETSI standards*", which is available from the ETSI Secretariat. Latest updates are available on the ETSI Web server (<https://ipr.etsi.org/>).

Pursuant to the ETSI Directives including the ETSI IPR Policy, no investigation regarding the essentiality of IPRs, including IPR searches, has been carried out by ETSI. No guarantee can be given as to the existence of other IPRs not referenced in ETSI SR 000 314 (or the updates on the ETSI Web server) which are, or may be, or may become, essential to the present document.

Trademarks

The present document may include trademarks and/or tradenames which are asserted and/or registered by their owners. ETSI claims no ownership of these except for any which are indicated as being the property of ETSI, and conveys no right to use or reproduce any trademark and/or tradename. Mention of those trademarks in the present document does not constitute an endorsement by ETSI of products, services or organizations associated with those trademarks.

DECT™, **PLUGTESTS™**, **UMTS™** and the ETSI logo are trademarks of ETSI registered for the benefit of its Members. **3GPP™** and **LTE™** are trademarks of ETSI registered for the benefit of its Members and of the 3GPP Organizational Partners. **oneM2M™** logo is a trademark of ETSI registered for the benefit of its Members and of the oneM2M Partners. **GSM®** and the GSM logo are trademarks registered and owned by the GSM Association.

Foreword

This Harmonised European Standard (EN) has been produced by ETSI Technical Committee Mobile Standards Group (MSG).

For non-EU countries the present document may be used for regulatory (Type Approval) purposes.

The present document has been prepared under the Commission's standardisation request C(2015) 5376 final [i.6] to provide one voluntary means of conforming to the essential requirements of Directive 2014/53/EU on the harmonisation of the laws of the Member States relating to the making available on the market of radio equipment and repealing Directive 1999/5/EC [i.1].

Once the present document is cited in the Official Journal of the European Union under that Directive, compliance with the normative clauses of the present document given in table A-1 confers, within the limits of the scope of the present document, a presumption of conformity with the corresponding essential requirements of that Directive and associated EFTA regulations.

The present document is part 18 of a multi-part deliverable. Full details of the entire series can be found in part 1 [i.4].

National transposition dates	
Date of adoption of this EN:	14 September 2021
Date of latest announcement of this EN (doa):	31 December 2021
Date of latest publication of new National Standard or endorsement of this EN (dop/e):	30 June 2022
Date of withdrawal of any conflicting National Standard (dow):	30 June 2023

Modal verbs terminology

In the present document "**shall**", "**shall not**", "**should**", "**should not**", "**may**", "**need not**", "**will**", "**will not**", "**can**" and "**cannot**" are to be interpreted as described in clause 3.2 of the [ETSI Drafting Rules](#) (Verbal forms for the expression of provisions).

"**must**" and "**must not**" are **NOT** allowed in ETSI deliverables except when used in direct citation.

Introduction

The present document is part of a set of standards developed by ETSI that are designed to fit in a modular structure to cover radio equipment within the scope of the Radio Equipment Directive [i.1]. The present document is produced following the guidance in ETSI EG 203 336 [i.2] as applicable.

1 Scope

The present document specifies technical characteristics and methods of measurements for the following equipment types:

- Multi-Standard Radio capable Base stations (NR, E-UTRA, UTRA, GSM/EDGE, NB-IoT).

Operation of NR in combination with UTRA or GSM/EDGE is not supported.

These radio equipment types are capable of operating in all or any part of the frequency bands given in table 1-1.

Table 1-1: Base station operating bands

Band designation and Band Category (note 1)	Direction of transmission	MSR Base Station operating bands	Relevant EC/ECC decision
1 (BC1)	Transmit	2 110 MHz to 2 170 MHz	[i.19] and [i.20].
	Receive	1 920 MHz to 1 980 MHz	
3 (BC2)	Transmit	1 805 MHz to 1 880 MHz	[i.17] and [i.18]
	Receive	1 710 MHz to 1 785 MHz	
7 (BC1) (note 3)	Transmit	2 620 MHz to 2 690 MHz	[i.21] and [i.22]
	Receive	2 500 MHz to 2 570 MHz	
8 (BC2)	Transmit	925 MHz to 960 MHz	[i.17] and [i.22]
	Receive	880 MHz to 915 MHz	
20 (BC1)	Transmit	791 MHz to 821 MHz	[i.12] and [i.13]
	Receive	832 MHz to 862 MHz	
22 (BC1) (note 13)	Transmit	3 510 MHz to 3 590 MHz	[i.7] and [i.24]
	Receive	3 410 MHz to 3 490 MHz	
28 (BC1) (notes 4 and 6)	Transmit	758 MHz to 803 MHz	[i.9] and [i.10]
	Receive	703 MHz to 748 MHz	
31 (BC1) (note 14)	Transmit	462,5 MHz to 467,5 MHz	[i.11]
	Receive	452,5 MHz to 457,5 MHz	
32 (BC1) (notes 10, 11 and 13)	Transmit	1 452 MHz to 1 496 MHz	[i.14], [i.15] and [i.16]
	Receive	N/A	
33 (BC3)	Transmit and Receive	1 900 MHz to 1 920 MHz	[i.19]
38 (BC3)	Transmit and Receive	2 570 MHz to 2 620 MHz	[i.22] and [i.23]
40 (BC3)	Transmit and Receive	2 300 MHz to 2 400 MHz	[i.21]
41 (BC3) (note 7)	Transmit and Receive	2 496 MHz to 2 690 MHz	[i.22] and [i.23]
42 (BC3)	Transmit and Receive	3 400 MHz to 3 600 MHz	[i.7] and [i.24]
43 (BC3)	Transmit and Receive	3 600 MHz to 3 800 MHz	[i.7] and [i.24]
50 (BC3) (note 10)	Transmit and Receive	1 432 MHz to 1 517 MHz	[i.15]
51 (BC3) (note 10)	Transmit and Receive	1 427 MHz to 1 432 MHz	[i.15]
65 (BC1) (notes 4 and 16)	Transmit	2 110 MHz to 2 200 MHz	[i.19], [i.20] and [i.25]
	Receive	1 920 MHz to 2 010 MHz	
67 (BC1) (notes 10 and 15)	Transmit	738 MHz to 758 MHz	[i.9] and [i.10]
	Receive	N/A	
68 (BC1) (note 15)	Transmit	753 MHz to 783 MHz	[i.9] and [i.10]
	Receive	698 MHz to 728 MHz	
69 (BC1) (notes 2 and 10)	Transmit	2 570 MHz to 2 620 MHz	[i.22] and [i.23]
	Receive	N/A	
72 (BC1) (note 14)	Transmit	461 MHz to 466 MHz	[i.11]
	Receive	451 MHz to 456 MHz	
75 (BC1) (notes 2 and 10)	Transmit	1 432 MHz to 1 517 MHz	[i.14], [i.15] and [i.16]
	Receive	N/A	

Band designation and Band Category (note 1)	Direction of transmission	MSR Base Station operating bands	Relevant EC/ECC decision
76 (BC1) (notes 2 and 10)	Transmit	1 427 MHz to 1 432 MHz	[i.15] and [i.16]
	Receive	N/A	
77 (BC3) (notes 8 and 12)	Transmit and Receive	3 300 MHz to 4 200 MHz	[i.7] and [i.24]
78 (BC3) (notes 9 and 12)	Transmit and Receive	3 300 MHz to 3 800 MHz	[i.7] and [i.24]
Band 87 (note 14)	Transmit	420 MHz to 425 MHz	[i.11]
	Receive	410 MHz to 415 MHz	
Band 88 (note 14)	Transmit	422 MHz to 427 MHz	[i.11]
	Receive	412 MHz to 417 MHz	
<p>NOTE 1: The band designations given are the MSR BS band designations. The relation between the band designations for MSR BS and the designations for NR, E-UTRA, UTRA and GSM/EDGE are given in table 4.4-1 of ETSI TS 137 141 [1].</p> <p>NOTE 2: The band is for NR and/or E-UTRA only.</p> <p>NOTE 3: The band is for NR, E-UTRA and/or UTRA only.</p> <p>NOTE 4: The band is for NR, E-UTRA and/or NB-IoT only.</p> <p>NOTE 5: Void.</p> <p>NOTE 6: In Europe according to [i.9] and [i.11], radio equipment in band 28 operates between 758 MHz and 791 MHz for the transmitter ($F_{DL_low} = 758$ MHz and $F_{DL_high} = 791$ MHz) and between 703 MHz and 736 MHz for the receiver ($F_{UL_low} = 703$ MHz and $F_{UL_high} = 736$ MHz).</p> <p>NOTE 7: In Europe according to [i.22] and [i.24], radio equipment in band 41 operates between 2 570 MHz and 2 620 MHz ($F_{DL_low} = 2 570$ MHz and $F_{DL_high} = 2 620$ MHz).</p> <p>NOTE 8: In Europe according to [i.7] and [i.25], radio equipment in band 77 operates between 3 400 MHz and 4 200 MHz ($F_{DL_low} = 3 400$ MHz and $F_{DL_high} = 4 200$ MHz).</p> <p>NOTE 9: In Europe according to [i.7] and [i.25], radio equipment in band 78 operates between 3 400 MHz and 3 800 MHz ($F_{DL_low} = 3 400$ MHz and $F_{DL_high} = 3 800$ MHz).</p> <p>NOTE 10: Restricted to NR and/or E-UTRA operation when carrier aggregation is configured. The downlink operating band is paired with the uplink operating band (external) of the carrier aggregation configuration that is supporting the configured Pcell.</p> <p>NOTE 11: Restricted to UTRA operation when dual band is configured (e.g. DB-DC-HSDPA or dual band 4C-HSDPA). The down link frequency(ies) of this band are paired with the uplink frequency(ies) of the other FDD band (external) of the dual band configuration.</p> <p>NOTE 12: The band is for NR only.</p> <p>NOTE 13: The band is for E-UTRA and/or UTRA only.</p> <p>NOTE 14: The band is for E-UTRA and/or NB-IoT only.</p> <p>NOTE 15: The band is for E-UTRA only.</p> <p>NOTE 16: This band includes two frequency ranges that are harmonised in Europe:</p> <ul style="list-style-type: none"> (a) According to [i.23] and [i.24], radio equipment in band 65 operates between 2 110 MHz to 2 170 MHz for the transmitter ($F_{DL_low} = 2 110$ MHz and $F_{DL_high} = 2 170$ MHz), and between 1 920 MHz to 1 980 MHz for the receiver ($F_{UL_low} = 1 920$ MHz and $F_{UL_high} = 1 980$ MHz). (b) Based on [i.25], radio equipment in band 65 operates between 2 170 MHz to 2 200 MHz for the transmitter ($F_{DL_low} = 2 170$ MHz and $F_{DL_high} = 2 200$ MHz) and between 1 980 MHz to 2 010 MHz for the receiver ($F_{UL_low} = 1 980$ MHz and $F_{UL_high} = 2 010$ MHz) as the Complementary Ground Component (CGC) of a Mobile-satellite service by reference to the present Harmonised Standard. 			

NOTE 1: For BS capable of multi-band operation, the supported operating bands may belong to different Band Categories.

The present document covers conducted requirements for multi-RAT capable NR, E-UTRA, UTRA and GSM/EDGE MSR Base Stations for 3GPP™ Release 9, 10, 11, 12, 13, 14 and 15. This includes the requirements for MSR operating bands from 3GPP Release 16.

NOTE 2: The relationship between the present document and essential requirements of article 3.2 of Directive 2014/53/EU [i.1] is given in annex A.

2 References

2.1 Normative references

References are either specific (identified by date of publication and/or edition number or version number) or non-specific. For specific references, only the cited version applies. For non-specific references, the latest version of the referenced document (including any amendments) applies.

Referenced documents which are not found to be publicly available in the expected location might be found at <https://docbox.etsi.org/Reference/>.

NOTE: While any hyperlinks included in this clause were valid at the time of publication, ETSI cannot guarantee their long term validity.

The following referenced documents are necessary for the application of the present document.

- [1] ETSI TS 137 141 (V15.11.0) (09-2020): "Digital cellular telecommunications system (Phase 2+) (GSM); Universal Mobile Telecommunications System (UMTS); LTE; 5G; NR, E-UTRA, UTRA and GSM/EDGE; Multi-Standard Radio (MSR) Base Station (BS) conformance testing (3GPP TS 37.141 version 15.11.0 Release 15)".
- [2] ETSI TS 125 104 (V15.5.0) (04-2019): "Universal Mobile Telecommunications System (UMTS); Base Station (BS) radio transmission and reception (FDD) (3GPP TS 25.104 version 15.5.0 Release 15)".
- [3] ETSI TS 125 105 (V15.0.0) (07-2018): "Universal Mobile Telecommunications System (UMTS); Base Station (BS) radio transmission and reception (TDD) (3GPP TS 25.105 version 15.0.0 Release 15)".
- [4] ETSI TS 136 104 (V15.9.0) (07-2020): "LTE; Evolved Universal Terrestrial Radio Access (E-UTRA); Base Station (BS) radio transmission and reception (3GPP TS 36.104 version 15.9.0 Release 15)".
- [5] ETSI TS 145 005 (V15.3.0) (04-2020): "Digital cellular telecommunications system (Phase 2+) (GSM); GSM/EDGE Radio transmission and reception (3GPP TS 45.005 version 15.3.0 Release 15)".
- [6] ETSI EN 301 908-3 (V13.1.1) (09-2019): "IMT cellular networks; Harmonised Standard for access to radio spectrum; Part 3: CDMA Direct Spread (UTRA FDD) Base Stations (BS)".
- [7] ETSI EN 301 908-14 (V15.1.1) (09-2021): "IMT cellular networks; Harmonised Standard for access to radio spectrum; Part 14: Evolved Universal Terrestrial Radio Access (E-UTRA) Base Stations (BS) Release 15".
- [8] Void.
- [9] ETSI EN 301 502 (V12.5.2) (03-2017): "Global System for Mobile communications (GSM); Base Station (BS) equipment; Harmonised Standard covering the essential requirements of article 3.2 of Directive 2014/53/EU".
- [10] ETSI TS 137 104 (V15.11.0) (09-2020): "Digital cellular telecommunications system (Phase 2+) (GSM); Universal Mobile Telecommunications System (UMTS); LTE; 5G; NR, E-UTRA, UTRA and GSM/EDGE; Multi-Standard Radio (MSR) Base Station (BS) radio transmission and reception (3GPP TS 37.104 version 15.11.0 Release 15)".
- [11] ETSI TS 136 141 (V15.9.0) (07-2020): "LTE; Evolved Universal Terrestrial Radio Access (E-UTRA); Base Station (BS) conformance testing (3GPP TS 36.141 version 15.9.0 Release 15)".
- [12] ETSI TS 125 141 (V15.4.0) (04-2019): "Universal Mobile Telecommunications System (UMTS); Base Station (BS) conformance testing (FDD) (3GPP TS 25.141 version 15.4.0 Release 15)".
- [13] ETSI TS 125 142 (V15.0.1) (07-2018): "Universal Mobile Telecommunications System (UMTS); Base Station (BS) conformance testing (TDD) (3GPP TS 25.142 version 15.0.1 Release 15)".

- [14] ETSI TS 151 021 (V15.3.0) (04-2020): "Digital cellular telecommunications system (Phase 2+) (GSM); Base Station System (BSS) equipment specification; Radio aspects (3GPP TS 51.021 version 15.3.0 Release 15)".
- [15] ETSI TS 138 141-1 (V15.6.0) (07-2020): "5G; NR; Base Station (BS) conformance testing; Part 1: Conducted conformance testing (3GPP TS 38.141-1 version 15.6.0 Release 15)".
- [16] ETSI TS 138 104 (V15.10.0) (07-2020): "5G; NR; Base Station (BS) radio transmission and reception (3GPP TS 38.104 version 15.10.0 Release 15)".
- [17] Void.

2.2 Informative references

References are either specific (identified by date of publication and/or edition number or version number) or non-specific. For specific references, only the cited version applies. For non-specific references, the latest version of the referenced document (including any amendments) applies.

NOTE: While any hyperlinks included in this clause were valid at the time of publication, ETSI cannot guarantee their long term validity.

The following referenced documents are not necessary for the application of the present document but they assist the user with regard to a particular subject area.

- [i.1] Directive 2014/53/EU of the European Parliament and of the council of 16 April 2014 on the harmonisation of the laws of the Member States relating to the making available on the market of radio equipment and repealing Directive 1999/5/EC.
- [i.2] ETSI EG 203 336 (V1.2.1) (05-2020): "Guide for the selection of technical parameters for the production of Harmonised Standards covering article 3.1(b) and article 3.2 of Directive 2014/53/EU".
- [i.3] ETSI TR 100 028 (all parts) (V1.4.1): "Electromagnetic compatibility and Radio spectrum Matters (ERM); Uncertainties in the measurement of mobile radio equipment characteristics".
- [i.4] ETSI EN 301 908-1 (V11.1.1): "IMT cellular networks; Harmonised Standard covering the essential requirements of article 3.2 of the Directive 2014/53/EU; Part 1: Introduction and common requirements".
- [i.5] Recommendation ITU-R SM.329-12 (09-2012): "Unwanted emissions in the spurious domain".
- [i.6] Commission implementing decision C(2015) 5376 final of 4.8.2015 on a standardisation request to the European Committee for Electrotechnical Standardisation and to the European Telecommunications Standards Institute as regards radio equipment in support of Directive 2014/53/EU of the European Parliament and of the Council.
- [i.7] Commission Implementing Decision (EU) 2019/235 of 24 January 2019 on amending Decision 2008/411/EC as regards an update of relevant technical conditions applicable to the 3 400-3 800 MHz frequency band.
- [i.8] ETSI TS 103 807 (V1.1.1): "Mobile Standards Group (MSG); IMT Cellular Networks Base Stations (BS)".
- [i.9] ECC Decision (15)01: "Harmonised technical conditions for mobile/fixed communications networks (MFCN) in the band 694-790 MHz including a paired frequency arrangement (Frequency Division Duplex 2x30 MHz) and an optional unpaired frequency arrangement (Supplemental Downlink)", Approved 06 March 2015.
- [i.10] Commission Implementing Decision (EU) 2016/687 of 28 April 2016 on the harmonisation of the 694-790 MHz frequency band for terrestrial systems capable of providing wireless broadband electronic communications services and for flexible national use in the Union.

- [i.11] ECC Decision (16)02: "Harmonised technical conditions and frequency bands for the implementation of Broadband Public Protection and Disaster Relief (BB-PPDR) systems", Approved 17 June 2016.
- [i.12] ECC Decision (09)03: "Harmonised conditions for mobile/fixed communications networks (MFCN) operating in the band 790 - 862 MHz", 30 October 2009.
- [i.13] Commission Decision 2010/267/EU of 6 May 2010 on harmonised technical conditions of use in the 790-862 MHz frequency band for terrestrial systems capable of providing electronic communications services in the European Union.
- [i.14] ECC Decision (13)03: "The harmonised use of the frequency band 1 452-1 492 MHz for Mobile/Fixed Communications Networks Supplemental Downlink (MFCN SDL)".
- [i.15] ECC Decision 17(06): "The harmonised use of the frequency bands 1 427-1 452 MHz and 1492-1518 MHz for Mobile/Fixed Communications Networks Supplemental Downlink (MFCN SDL)", Approved 17 November 2017, corrected 2 March 2018.
- [i.16] Commission Implementing Decision (EU) 2018/661 of 26 April 2018 amending Implementing Decision (EU) 2015/750 on the harmonisation of the 1452-1492 MHz frequency band for terrestrial systems capable of providing electronic communications services in the Union as regards its extension in the harmonised 1427-1452 MHz and 1492-1517 MHz frequency bands.
- [i.17] Implementing Decision 2011/251/EU amending Decision 2009/766/EC on the harmonisation of the 900 MHz and 1800 MHz frequency bands for terrestrial systems capable of providing pan-European electronic communications services in the Community.
- [i.18] ECC Decision (06)13: "Designation of the bands 880-915 MHz, 925-960 MHz, 1710-1785 MHz and 1805-1880 MHz for terrestrial UMTS, LTE, WiMAX and IoT cellular systems", Approved 01 December 2006, Amended 8 March 2019.
- [i.19] ECC Decision (06)01: "The harmonised utilisation of the bands 1920-1980 MHz and 2110-2170 MHz for mobile/fixed communications networks (MFCN) including terrestrial IMT systems", Approved 24 March 2006, Amended 8 March 2019.
- [i.20] Commission Implementing Decision (EU) 2020/667 of 6 May 2020 amending Decision 2012/688/EU as regards an update of relevant technical conditions applicable to the frequency bands 1 920-1 980 MHz and 2 110-2 170 MHz.
- [i.21] ECC Decision 14(02): "Harmonised technical and regulatory conditions for the use of the band 2 300-2 400 MHz for Mobile/Fixed Communications Networks (MFCN)", Approved 27 June 2014.
- [i.22] ECC Decision 05(05): "Harmonised utilization of spectrum for Mobile/Fixed Communications Networks (MFCN) operating within the band 2 500-2 690 MHz", Approved 18 March 2005, Amended 05 July 2019.
- [i.23] Commission Implementing Decision (EU) 2020/636 of 8 May 2020 amending Decision 2008/477/EC as regards an update of relevant technical conditions applicable to the 2 500-2 690 MHz frequency band.
- [i.24] ECC Decision 11(06): "Harmonised frequency arrangements and least restrictive technical conditions (LRTC) for mobile/fixed communications networks (MFCN) operating in the band 3400-3800 MHz", Approved 09 December 2011, Amended 26 October 2018.
- [i.25] ECC Decision 06(09): "Designation of the bands 1980-2010 MHz and 2170-2200 MHz for use by systems in the Mobile-Satellite Service including those supplemented by a Complementary Ground Component (CGC)", Approved 01 December 2006, Amended 05 September 2007.

3 Definition of terms, symbols and abbreviations

3.1 Terms

For the purposes of the present document, the following terms apply:

band category: group of operating bands for which the same MSR scenarios apply

NOTE: The band categories for MSR BS are defined in clause 4.4 of ETSI TS 137 141 [1] and are listed in table 1-1.

Base Station class: wide area Base Station, medium range Base Station or local Area Base Station, as declared by the manufacturer

Base Station RF bandwidth: bandwidth in which a Base Station transmits and/or receives single or multiple carrier(s) and/or RATs simultaneously within a supported operating band

NOTE: In single carrier operation, the Base Station RF bandwidth is equal to the channel bandwidth.

Base Station RF bandwidth edge: frequency of one of the edges of the Base Station RF bandwidth

carrier: modulated waveform conveying the NR, E-UTRA, UTRA or GSM/EDGE physical channels

carrier aggregation: aggregation of two or more NR or E-UTRA component carriers in order to support wider transmission bandwidths

carrier aggregation band: set of one or more operating bands across which multiple NR or E-UTRA carriers are aggregated with a specific set of technical requirements

NOTE: The term channel bandwidth is referred to as BS channel bandwidth in the NR specifications, since for NR the BS and UE may operate with differing bandwidths.

carrier power: power at the antenna connector in the channel bandwidth of the carrier averaged over at least one subframe for NR or E-UTRA, at least one slot for UTRA and the useful part of the burst for GSM/EDGE

channel bandwidth: RF bandwidth supporting a single NR, E-UTRA, UTRA or GSM/EDGE RF carrier

NOTE: The channel bandwidth is measured in MHz and is used as a reference for transmitter and receiver RF requirements.

configured carrier power: target maximum power for a specific carrier for the operating mode set in the BS

contiguous spectrum: spectrum consisting of a contiguous block of spectrum with no sub-block gap(s)

downlink operating band: part of the operating band designated for downlink

inter RF bandwidth gap: frequency gap between two consecutive Base Station RF bandwidths that are placed within two supported operating bands

inter-band gap: frequency gap between two supported consecutive operating bands

intra-band contiguous carrier aggregation: contiguous NR or E-UTRA carriers aggregated in the same operating band

local area Base Station: Base Stations characterized by requirements derived from picocell scenarios with a BS to UE minimum coupling loss equal to 45 dB

lower Base Station RF bandwidth edge: frequency of the lower edge of the Base Station RF bandwidth, used as a frequency reference point for transmitter and receiver requirements

lower sub-block edge: frequency at the lower edge of one sub-block

NOTE: It is used as a frequency reference point for both transmitter and receiver requirements.

maximum Base Station RF bandwidth: maximum RF bandwidth supported by a Base Station within each supported operating band

NOTE: The Maximum Base Station RF bandwidth for BS configured for contiguous and non-contiguous operation within each supported operating band is declared separately.

maximum carrier output power: carrier power available at the antenna connector for a specified reference condition

maximum radio bandwidth: maximum frequency difference between the upper edge of the highest used carrier and the lower edge of the lowest used carrier

maximum throughput: maximum achievable throughput for a reference measurement channel

maximum total output power: sum of the power of all carriers available at the antenna connector for a specified reference condition

MB-MSR Base Station: MSR Base Station characterized by the ability of its transmitter and/or receiver to process two or more carriers in common active RF components simultaneously, where at least one carrier is configured at a different operating band (which is not a sub-band or superseding-band of another supported operating band) than the other carrier(s)

mean power: power measured in the bandwidth and period of measurement applicable for each RAT

NOTE: Mean power for an E-UTRA carrier is defined in clause 3.1 of ETSI TS 136 141 [11] and mean power for a UTRA carrier is defined in clause 3.1 of ETSI TS 125 141 [12]. In case of multiple carriers, the mean power is the sum of the mean power of all carriers.

measurement bandwidth: bandwidth in which an emission level is specified

medium range Base Station (BS): Base Stations characterized by requirements derived from micro cell scenarios with a BS to UE minimum coupling loss equal to 53 dB

MSR Base Station (BS): Base Station characterized by the ability of its receiver and transmitter to process two or more carriers in common active RF components simultaneously in a declared Base Station RF bandwidth, where at least one carrier is of a different RAT than the other carrier(s)

multi-band connector: *antenna* connector of the *BS type 1-C* associated with a transmitter or receiver that is characterized by the ability to process two or more carriers in common active RF components simultaneously, where at least one carrier is configured at a different *operating band* than the other carrier(s) and where this different *operating band* is not a sub-band or superseding-band of another supported operating band

multi-band receiver: receiver characterized by the ability to process two or more carriers in common active RF components simultaneously, where at least one carrier is configured at a different operating band (which is not a sub-band or superseding-band of another supported operating band) than the other carrier(s)

multi-band transmitter: transmitter characterized by the ability to process two or more carriers in common active RF components simultaneously, where at least one carrier is configured at a different operating band (which is not a sub-band or superseding-band of another supported operating band) than the other carrier(s)

NB-IoT guard band operation: operation of NB-IoT utilizing the unused resource block(s) within a E-UTRA carrier's guard-band

NB-IoT in-band operation: operation of NB-IoT utilizing the resource block(s) within a normal E-UTRA carrier

NB-IoT standalone operation: operation of NB-IoT utilizing its own spectrum, for example the spectrum currently being used by GERAN systems as a replacement of one or more GSM carriers, as well as scattered spectrum for potential IoT deployment

non-contiguous spectrum: spectrum consisting of two or more sub-blocks separated by sub-block gap(s)

operating band: frequency range in which NR, E-UTRA, UTRA or GSM/EDGE operates (paired or unpaired), that is defined with a specific set of technical requirements

NOTE: The operating band(s) for a Base Station is declared by the manufacturer. Operating bands have designations according to table 1-1.

single-RAT operation: operation of a Base Station in an operating band with only one RAT configured in that operating band

sub-band: part of the uplink and downlink frequency range of the operating band

sub-block: contiguous allocated block of spectrum for use by the same Base Station

NOTE: There may be multiple instances of sub-blocks within a Base Station RF bandwidth.

sub-block bandwidth: bandwidth of one sub-block

sub-block gap: frequency gap between two consecutive sub-blocks within a Base Station RF bandwidth, where the RF requirements in the gap are based on co-existence for un-coordinated operation

superseding-band: band including the whole of the uplink and downlink frequency range of the operating band

throughput: number of payload bits successfully received per second for a reference measurement channel in a specified reference condition

total RF bandwidth: maximum sum of Base Station RF bandwidths in all supported operating bands

transmission bandwidth: bandwidth of an instantaneous NR or E-UTRA transmission from a UE or BS, measured in Resource Block units

transmission bandwidth configuration: highest NR or E-UTRA transmission bandwidth allowed for uplink or downlink in a given channel bandwidth, measured in resource block units

transmitter OFF period: time period during which the BS transmitter is not allowed to transmit

transmitter ON period: time period during which the BS transmitter is transmitting data and/or reference symbols, e.g. data subframes or DwPTS

transmitter transient period: time period during which the transmitter is changing from the OFF period to the ON period or vice versa

uplink operating band: part of the operating band designated for uplink

upper Base Station RF bandwidth edge: frequency of the upper edge of the Base Station RF bandwidth, used as a frequency reference point for transmitter and receiver requirements

upper sub-block edge: frequency at the upper edge of one sub-block

NOTE: It is used as a frequency reference point for both transmitter and receiver requirements.

wide area Base Station: Base Stations characterized by requirements derived from macro cell scenarios with a BS to UE minimum coupling loss equal to 70 dB

NOTE: This Base Station class has the same requirements as the general purpose Base Station in the sixth release version of the present document, corresponding to 3GPP Release 8.

3.2 Symbols

For the purposes of the present document, the following symbols apply:

BW_{Channel}	Channel bandwidth (for E-UTRA and NR)
BW_{Config}	Transmission bandwidth configuration (for E-UTRA), expressed in MHz, where $BW_{\text{Config}} = N_{\text{RB}} \times 180 \text{ kHz}$ in the uplink and $BW_{\text{Config}} = 15 \text{ kHz} + N_{\text{RB}} \times 180 \text{ kHz}$ in the downlink. Transmission bandwidth configuration (for NR), where $BW_{\text{Config}} = N_{\text{RB}} \times \text{SCS} \times 12$

BW_{RF}	Base Station RF bandwidth, where $BW_{RF} = F_{BW\ RF,high} - F_{BW\ RF,low}$
B_{RFBW}	Maximum Base Station RF bandwidth located at the bottom of the supported frequency range in the operating band
CA_X	CA for band X where X is the applicable E-UTRA operating band
f	Frequency
Δf	Separation between the Base Station RF bandwidth edge frequency and the nominal -3 dB point of the measuring filter closest to the carrier frequency
Δf_{max}	The largest value of Δf used for defining the requirement
Δf_{OBUE}	Maximum offset of the <i>operating band</i> unwanted emissions mask from the downlink <i>operating band</i> edge
Δf_{OOB}	Maximum offset of the out-of-band boundary from the uplink <i>operating band</i> edge
F_C	Carrier centre frequency
F_{filter}	Filter centre frequency
f_offset	Separation between the Base Station RF bandwidth edge frequency and the centre of the measuring filter
f_offset_max	The maximum value of f_offset used for defining the requirement
$F_{block,high}$	Upper sub-block edge, where $F_{block,high} = F_{C,block,high} + F_{offset, RAT}$
$F_{block,low}$	Lower sub-block edge, where $F_{block,low} = F_{C,block,low} - F_{offset, RAT}$
$F_{BW\ RF,high}$	Upper Base Station RF bandwidth edge, where $F_{BW\ RF,high} = F_{C,high} + F_{offset, RAT}$
$F_{BW\ RF,low}$	Lower Base Station RF bandwidth edge, where $F_{BW\ RF,low} = F_{C,low} - F_{offset, RAT}$
$F_{C,block, high}$	Center frequency of the highest transmitted/received carrier in a sub-block
$F_{C,block, low}$	Center frequency of the lowest transmitted/received carrier in a sub-block
$F_{C,high}$	Center frequency of the highest transmitted/received carrier
$F_{C,low}$	Center frequency of the lowest transmitted/received carrier
$F_{offset, RAT}$	Frequency offset from the centre frequency of the <i>highest</i> transmitted/received carrier to the <i>upper</i> Base Station RF bandwidth edge, sub-block edge or inter-RF bandwidth edge, or from the centre frequency of the <i>lowest</i> transmitted/received carrier to the <i>lower</i> Base Station RF bandwidth edge, sub-block edge or inter-RF bandwidth edge for a specific RAT
F_{UL_low}	The lowest frequency of the uplink operating band
F_{UL_high}	The highest frequency of the uplink operating band
M_{RFBW}	Maximum Base Station RF bandwidth located in the middle of the supported frequency range in the operating band
$P_{GSMcarrier}$	Power level of the GSM/EDGE carrier adjacent to the RF bandwidth edge
P_{max}	Maximum total output power
$P_{max,c}$	Maximum carrier output power
$P_{NB-IoTcarrier}$	Power level of the NB-IoT carrier adjacent to the RF bandwidth edge
$P_{Rated,c}$	Rated carrier output power
$P_{REFSENS}$	Reference Sensitivity power level
T_{RFBW}	Maximum Base Station RF bandwidth located at the top of the supported frequency range in the operating band
W_{gap}	Sub-block gap size or Inter RF bandwidth gap size

3.3 Abbreviations

For the purposes of the present document, the following abbreviations apply:

4C-HSDPA	Four-Carrier HSDPA
ACLR	Adjacent Channel Leakage Ratio
AM	Amplitude Modulation
ARFCN	Absolute Radio Frequency Channel Number
BC	Band Category
BER	Bit Error Ratio
BS	Base Station
BTS	Base Transceiver Station

BW	BandWidth
CA	Carrier Aggregation
CACLR	Cumulative Adjacent Channel Leakage Ratio
CEPT	European Conference of Postal and Telecommunications administrations
CS	Capability Set
CW	Continuous Wave
DB-DC-HSDPA	Dual Band - Dual Cell - HSDPA
DC	Direct Current
DL	DownLink
DTT	Digital Terrestrial Television
DwPTS	Downlink Part of The special Subframe

NOTE: For E-UTRA TDD operation.

EC	European Communities
ECC	Electronic Communications Committee
EDGE	Enhanced Data rates for GSM Evolution
EFTA	European Free Trade Association
EU	European Union
EUT	Equipment Under Test
E-UTRA	Evolved - Universal Terrestrial Radio Access
FDD	Frequency Division Duplex
FRC	Fixed Reference Channel

NOTE: The fixed reference channels for E-UTRA are detailed in annex A of ETSI TS 136 141 [11].

GMSK	Gaussian Minimum Shift Keying
GSM	Global System for Mobile communications
HSDPA	High Speed Downlink Packet Access
IMD	InterMoDulation
IMT	International Mobile Telecommunications
ITU-R	International Telecommunication Union - Radiocommunication sector
LA	Local Area
MB-MSR	Multi-Band - Multi-Standard Radio
MBT	Multi-Band Testing
MC-BTS	Multi-Carrier - Base Transceiver Station
MR	Medium Range
MS	Mobile Station
MSR	Multi-Standard Radio
NB-IoT	NarrowBand - Internet of Things
NR	New Radio
NR-ARFCN	NR Absolute Radio Frequency Channel Number
OBUE	Operating Band Unwanted Emissions
Pcell	Primary cell
RAT	Radio Access Technology
RB	Resource Block (for E-UTRA)
RF	Radio Frequency
RMS	Root Mean Square (value)
RRC	Root-Raised Cosine
RX	Receiver
SBT	Single Band Testing
SCS	Sub-Carrier Spacing
TC	Test Configuration
TDD	Time Division Duplex
TX	Transmitter
UARFCN	UTRA Absolute Radio Frequency Channel Number
UE	User Equipment
UEM	operating band Unwanted Emissions Mask
UL	UpLink
UTRA	Universal Terrestrial Radio Access
WA	Wide Area

4 Technical requirements specifications

4.1 Environmental profile

The technical requirements of the present document apply under the environmental profile for operation of the equipment, which shall be in accordance with its intended use. The equipment shall comply with all the technical requirements of the present document at all times when operating within the boundary limits of the operational environmental profile defined by its intended use.

4.2 Conformance requirements

4.2.1 Introduction

The requirements in the present document are based on the assumption that the operating band (see table 1-1) is shared between systems of the IMT family (for band 3 and 8 also GSM) or systems having compatible characteristics.

To meet the essential requirement under article 3.2 of Directive 2014/53/EU [i.1] for IMT Base Stations (BSs), a set of essential parameters in addition to those in ETSI EN 301 908-1 [i.4] have been identified. Table 4.2.1-1 provides a cross reference between these essential parameters and the corresponding technical requirements for equipment within the scope of the present document.

Table 4.2.1-1: Cross references

Essential parameter	Corresponding technical requirements	Corresponding test suite
Transmitter spectrum mask	4.2.2 Operating band unwanted emissions	5.3.1
Transmitter unwanted emissions in the out-of-band domain	4.2.3 Adjacent Channel Leakage power Ratio (ACLR)	5.3.2
Transmitter unwanted emissions in the spurious domain	4.2.4 Transmitter spurious emissions	5.3.3
Transmitter power accuracy	4.2.5 Base station maximum output power	5.3.4
Transmitter intermodulation attenuation	4.2.6 Transmit intermodulation	5.3.5
Receiver unwanted emissions in the spurious domain	4.2.7 Receiver spurious emissions	5.3.6
Receiver blocking	4.2.8 In-band blocking	5.3.7
Receiver desensitization	4.2.9 Out-of-band blocking	5.3.8
Receiver radio-frequency intermodulation	4.2.10 Receiver intermodulation characteristics	5.3.9
Receiver adjacent signal selectivity	4.2.11 Narrowband blocking	5.3.10
Receiver sensitivity	4.2.12 Reference sensitivity level	5.3.11

The manufacturer shall declare the following:

- The supported capability set(s) according to clause 4.7.1 of ETSI TS 137 141 [1].
- The supported RF configurations according to clause 4.7.2 of ETSI TS 137 141 [1].
- The intended class of the BS under test.
- The NB-IoT parameters according to clauses 4.6.6 and 4.6.7 of ETSI TS 137 141 [1].

The technical requirements in the present document apply for the declared Base Station class and operating band(s) as outlined for each requirement. For a Base Station supporting more than one operating band, conformance testing for each technical requirement in clause 5 shall be performed for each operating band.

NOTE 1: For NB-IoT guard band operation, the NB-IoT edge should be placed at least 200 kHz away from the E-UTRA channel edge, in absence of an agreement between operators using adjacent blocks. NB-IoT guard band operation is only foreseen within E-UTRA channel bandwidths of 10 MHz and higher. This statement is provided for information and does not have any impact on the conformance requirements or essential radio test suites in the present document.

For GSM/EDGE operation of a BS, the requirements according to the applicable multicarrier BTS class apply. The Wide Area BS, Medium Range BS and Local Area BS in the present document correspond to the Wide Area multicarrier BTS, Medium Range multicarrier BTS and Local Area multicarrier BTS respectively in the GSM/EDGE specifications [14].

All technical requirements shall apply with a frequency offset from the lowest and highest carrier frequencies transmitted or received in the specified operating band to the Base Station RF bandwidth edges ($F_{\text{offset, RAT}}$) that is specific for each RAT in each Band Category as defined in clause 4.4 of ETSI TS 137 141 [1].

The technical requirements also apply to the BS configurations described in annex B.

For BS capable of multi-band operation (for NR this refers to BS type 1-C with a multi-band connector), the technical requirements in the present clause shall apply for each supported operating band unless otherwise stated. For some requirements it is explicitly stated that specific additions or exclusions to the requirement shall apply for BS capable of multi-band operation. In the case of multiband operation of a BS, single-RAT operation and the corresponding applicability of the requirements for each operating band is determined based on the RAT configuration within only that operating band, unless otherwise stated.

For BS capable of multi-band operation, various structures in terms of combinations of different transmitter and receiver implementations (multi-band or single band) with mapping of transceivers to one or more antenna port(s) in different ways are possible. In the case where multiple bands are mapped on an antenna connector, the exclusions or provisions for multi-band capable BS are applicable to this antenna connector. In the case where a single band is mapped on an antenna connector, the following shall apply:

- Single-band transmitter spurious emissions, operating band unwanted emissions, ACLR, transmitter intermodulation and receiver spurious emissions requirements shall apply to this antenna connector that is mapped to single-band.
- If the BS is configured for single-band operation, single-band requirements shall apply to this antenna connector configured for single-band operation and no exclusions or provisions for multi-band capable BS are applicable. Single-band requirements are tested separately at the antenna connector configured for single-band operation, with all other antenna connectors terminated.

For a band supported by a Base Station where the transmitted carriers are not processed in active RF components together with carriers in any other band, single-band transmitter requirements shall apply. For a band supported by a Base Station where the received carriers are not processed in active RF components together with carriers in any other band, single-band receiver requirements shall apply.

For a BS capable of multi-band operation supporting BC3 bands for TDD, the RF requirements in the present document assume synchronized operation, where no simultaneous uplink and downlink occur between the bands.

The RF requirements in the present document do not apply for multi-band operation supporting bands for both FDD and TDD.

For BS supports multiple multi-band combinations, the test(s) shall be applied using the following principles:

- 1) The supported multi-band combination covering the widest radio bandwidth should be tested.
- 2) Among the remaining supported multi-band combinations, the following ones should also be tested:
 - Those with a larger rated total output power (per band or per band combination).
 - Those with a larger total number of supported carriers (per band or per band combination).
 - Those with a larger Maximum Base Station RF Bandwidth (per band).

For a BS declared to be capable of E-UTRA (and where applicable NR) with NB-IoT in-band operations, the limits for subPRB allocation do not apply.

NOTE 2: For a BS operating in band 20, additional limits for protection of DTT are described in clause 6.6.2.5.4.3 of ETSI TS 137 141 [1]. This statement is provided for information and does not have any impact on the conformance requirements or essential radio test suites in the present document.

NOTE 3: For a BS operating in band 32, 50, 51, 75 and 76, additional limits for protection are described in clause 6.6.2.5.4.6 of ETSI TS 137 141 [1]. This statement is provided for information and does not have any impact on the conformance requirements or essential radio test suites in the present document.

NOTE 4: Additional requirements arising from EC/CEPT spectrum regulatory framework that apply to specific equipment applicable to specific cases in certain countries and/or in certain geographical areas are addressed in ETSI TS 103 807 [i.8].

4.2.2 Operating band unwanted emissions

4.2.2.1 Definition

Unwanted emissions consist of out-of-band emissions and spurious emissions (Recommendation ITU-R SM.329-12 [i.5]). Out of band emissions are emissions immediately outside the channel bandwidth resulting from the modulation process and non-linearity in the transmitter but excluding spurious emissions. Spurious emissions are emissions which are caused by unwanted transmitter effects such as harmonics emission, parasitic emission, intermodulation products and frequency conversion products, but exclude out-of-band emissions. Operating band unwanted emissions cover both out-of-band and spurious domain frequencies.

The Operating band unwanted emission limits are defined from Δf_{OBUE} below the lowest frequency of each supported downlink operating band to the lower Base Station RF bandwidth edge located at $F_{\text{BW RF,low}}$ and from the upper Base Station RF bandwidth edge located at $F_{\text{BW RF,high}}$ up to Δf_{OBUE} above the highest frequency of each supported downlink operating band. In addition, for a BS operating in non-contiguous spectrum, it shall apply inside any sub-block gap. In addition, for a BS operating in multiple bands, it applies inside any Inter RF bandwidth gap. The values of Δf_{OBUE} are defined in table 4.2.2.1-1. For a BS with multi-RAT operation where the individual RATs are in different RAT specific bands that partially or fully overlap; Δf_{OBUE} is according to the combined frequency range occupied by the overlapping bands.

The additional limits in clauses 4.2.2.2.7 and 4.2.2.2.8 also apply further than Δf_{OBUE} from the edges of downlink operating band.

Table 4.2.2.1-1: Maximum offset of OBUE outside the downlink operating band

Operating band characteristics	Δf_{OBUE} [MHz]
$F_{\text{DL_high}} - F_{\text{DL_low}} \leq 200$ MHz	10
$200 \text{ MHz} < F_{\text{DL_high}} - F_{\text{DL_low}} \leq 900$ MHz	40

The requirements shall apply whatever the type of transmitter considered and for all transmission modes foreseen by the manufacturer's specification, except for any operating band with GSM/EDGE single RAT operation. The requirements in ETSI TS 145 005 [5] as defined in clause 4.2.2.2.3 shall apply to an MSR Base Station for any operating band with GSM/EDGE single RAT operation in Band Category 2.

For BS capable of multi-band operation where multiple bands are mapped on separate antenna connectors, the single-band requirements shall apply and the cumulative evaluation of the emission limit in the inter-RF bandwidth gap are not applicable.

4.2.2.2 Limits

4.2.2.2.1 Limits for Band Categories 1 and 3

For a Wide Area BS operating in Band Category 1 or Band Category 3 the requirement shall apply outside the Base Station RF bandwidth edges. In addition, for a Wide Area BS operating in non-contiguous spectrum, it shall apply inside any sub-block gap. In addition, for a Wide Area BS operating in multiple bands, it applies inside any Inter RF bandwidth gap.

For a Medium Range BS operating in Band Category 1 the requirement shall apply outside the Base Station RF bandwidth edges. In addition, for a Medium Range BS operating in non-contiguous spectrum, it shall apply inside any sub-block gap. In addition, for a Medium Range BS operating in multiple bands, it applies inside any Inter RF bandwidth gap.

For a Local Area BS operating in Band Category 1 the requirement shall apply outside the Base Station RF bandwidth edges. In addition, for a Local Area BS operating in non-contiguous spectrum, it shall apply inside any sub-block gap. In addition, for a Local Area BS operating in multiple bands, it applies inside any Inter RF bandwidth gap.

Outside the Base Station RF bandwidth edges, emissions shall not exceed the maximum levels specified in tables 4.2.2.2.1-1 to 4.2.2.2.1-8, where:

- Δf is the separation between the Base Station RF bandwidth edge frequency and the nominal -3 dB point of the measuring filter closest to the carrier frequency.
- f_{offset} is the separation between the Base Station RF bandwidth edge frequency and the centre of the measuring filter.
- $f_{\text{offset}_{\text{max}}}$ is the offset to the frequency Δf_{OBUE} outside the downlink operating band.
- Δf_{max} is equal to $f_{\text{offset}_{\text{max}}}$ minus half of the bandwidth of the measuring filter.

For a BS operating in multiple bands, inside any inter-RF bandwidth gaps with $W_{\text{gap}} < 2 \times \Delta f_{\text{OBUE}}$, emissions shall not exceed the cumulative sum of the test requirements specified at the Base Station RF bandwidth edges on each side of the inter-RF bandwidth gap. The test requirement for Base Station RF bandwidth edge is specified in tables 4.2.2.2.1-1 to 4.2.2.2.1-8, where in this case:

- Δf is the separation between the Base Station RF bandwidth edge frequency and the nominal -3 dB point of the measuring filter closest to the carrier frequency.
- f_{offset} is the separation between the Base Station RF bandwidth edge frequency and the centre of the measuring filter.
- $f_{\text{offset}_{\text{max}}}$ is equal to the Inter RF bandwidth gap minus half of the bandwidth of the measuring filter.
- Δf_{max} is equal to $f_{\text{offset}_{\text{max}}}$ minus half of the bandwidth of the measuring filter.

For BS capable of multi-band operation where multiple bands are mapped on the same antenna connector, the operating band unwanted emission limits apply also in a supported operating band without any carriers transmitted, in the case where there are carriers transmitted in other supported operating band(s). In this case where there is no carrier transmitted in an operating band the operating band unwanted emission limit, as defined in the tables of the present clause for the largest frequency offset (Δf_{max}), of a band where there are no carriers transmitted shall apply from Δf_{OBUE} below the lowest frequency, up to Δf_{OBUE} above the highest frequency of the supported downlink operating band without any carrier transmitted; and no cumulative limits are applied in the inter-band gap between a supported downlink band with carrier(s) transmitted and a downlink band without any carrier transmitted.

Inside any sub-block gap for a BS operating in non-contiguous spectrum, emissions shall not exceed the cumulative sum of the test requirements specified for the adjacent sub-blocks on each side of the sub-block gap. The test requirement for each sub-block is specified in tables 4.2.2.2.1-1 to 4.2.2.2.1-8, where in this case:

- Δf is the separation between the sub-block edge frequency and the nominal -3 dB point of the measuring filter closest to the sub-block edge frequency.
- f_{offset} is the separation between the sub-block edge frequency and the centre of the measuring filter.
- $f_{\text{offset}_{\text{max}}}$ is equal to the sub-block gap bandwidth minus half of the bandwidth of the measuring filter.
- Δf_{max} is equal to $f_{\text{offset}_{\text{max}}}$ minus half of the bandwidth of the measuring filter.

Applicability of Wide Area operating band unwanted emission requirements in tables 4.2.2.2.1-1, 4.2.2.2.1-2, 4.2.2.2.1-2B, 4.2.2.2.1-2C and 4.2.2.2.1-2D is specified in table 4.2.2.2.1-0.

Table 4.2.2.1-0: Applicability of operating band unwanted emission requirements for BC1 and BC3 Wide Area BS

NR Band operation	Standalone NB-IoT carrier adjacent to the BS RF bandwidth edge	UTRA supported (note)	Applicable requirement table
None	Y/N	Y/N	4.2.2.2.1-1 4.2.2.2.1-2
Bands 1, 7, 38 and 65	N	N	4.2.2.2.1-1 4.2.2.2.1-2
Any	Y	N	4.2.2.2.1-1 4.2.2.2.1-2
Any below 1 GHz	N	N	4.2.2.2.1-2B
Any above 1 GHz except for bands 1, 7, 38 or 65	N	N	4.2.2.2.1-2C 4.2.2.2.1-2D

NOTE: NR operation with UTRA is not supported in the present document.

Table 4.2.2.1-1: Wide Area BS operating band Unwanted Emission Mask (UEM) for BC1 and BC3 for bands ≤ 3 GHz for BS not supporting NR (except for BS operating in Band 1, 7, 38 or 65) or (irrespective of NR support) BS with standalone NB-IoT at the BS RF bandwidth edge

Frequency offset of measurement filter -3 dB point, Δf	Frequency offset of measurement filter centre frequency, f_{offset}	Test requirement (see notes 3 and 4)	Measurement bandwidth
$0 \text{ MHz} \leq \Delta f < 0,2 \text{ MHz}$ (note 5)	$0,015 \text{ MHz} \leq f_{\text{offset}} < 0,215 \text{ MHz}$	-12,5 dBm	30 kHz
$0,2 \text{ MHz} \leq \Delta f < 1 \text{ MHz}$	$0,215 \text{ MHz} \leq f_{\text{offset}} < 1,015 \text{ MHz}$	$-12,5 \text{ dBm} - 15 \cdot \left(\frac{f_{\text{offset}}}{\text{MHz}} - 0,215 \right) \text{ dB}$ (note 6)	30 kHz
(note 1)	$1,015 \text{ MHz} \leq f_{\text{offset}} < 1,5 \text{ MHz}$	-24,5 dBm (note 6)	30 kHz
$1 \text{ MHz} \leq \Delta f \leq \min(\Delta f_{\text{max}}, 10 \text{ MHz})$	$1,5 \text{ MHz} \leq f_{\text{offset}} < \min(f_{\text{offset}_{\text{max}}}, 10,5 \text{ MHz})$	-11,5 dBm (note 6)	1 MHz
$10 \text{ MHz} \leq \Delta f \leq \Delta f_{\text{max}}$	$10,5 \text{ MHz} \leq f_{\text{offset}} < f_{\text{offset}_{\text{max}}}$	-15 dBm (see notes 2 and 6)	1 MHz

NOTE 1: This frequency range ensures that the range of values of f_{offset} is continuous.

NOTE 2: The requirement is not applicable when $\Delta f_{\text{max}} < \Delta f_{\text{OBUE}}$.

NOTE 3: For MSR BS supporting non-contiguous spectrum operation within any operating band the test requirement within sub-block gaps is calculated as a cumulative sum of contributions from adjacent sub-blocks on each side of the sub-block gap, where the contribution from the far-end sub-block shall be scaled according to the measurement bandwidth of the near-end sub-block. Exception is $\Delta f \geq 10$ MHz from both adjacent sub-blocks or Base Station RF Bandwidth on each side of the sub-block gap, where the test requirement within sub-block gaps shall be -15 dBm/MHz (for MSR BS supporting multi-band operation, either this limit or -16 dBm/100 kHz with correspondingly adjusted f_{offset} shall apply for this frequency offset range for operating bands < 1 GHz).

NOTE 4: For MSR BS supporting multi-band operation with Inter RF bandwidth gap $< 2 \times \Delta f_{\text{OBUE}}$ the test requirement within the Inter RF bandwidth gaps is calculated as a cumulative sum of contributions from adjacent sub-blocks on each side of the Inter RF bandwidth gap, where the contribution from the far-end sub-block or Base Station RF Bandwidth shall be scaled according to the measurement bandwidth of the near-end sub-block or Base Station RF Bandwidth.

NOTE 5: For operation with a standalone NB-IoT carrier adjacent to the Base Station RF Bandwidth edge, the limits in table 4.2.2.2.1-2A apply for $0 \text{ MHz} \leq \Delta f < 0,15 \text{ MHz}$.

NOTE 6: For MSR BS supporting multi-band operation, either this limit or -16 dBm/100 kHz with correspondingly adjusted f_{offset} shall apply for this frequency offset range for operating bands < 1 GHz.

**Table 4.2.2.1-2: Wide Area BS operating band Unwanted Emission Mask (UEM)
for BC1 and BC3 for bands > 3 GHz for BS not supporting NR or (irrespective of NR support)
BS with standalone NB-IoT at the BS RF bandwidth edge**

Frequency offset of measurement filter -3 dB point, Δf	Frequency offset of measurement filter centre frequency, f_{offset}	Test requirement (see notes 3 and 4)	Measurement bandwidth
$0 \text{ MHz} \leq \Delta f < 0,2 \text{ MHz}$	$0,015 \text{ MHz} \leq f_{\text{offset}} < 0,215 \text{ MHz}$	-12,2 dBm	30 kHz
$0,2 \text{ MHz} \leq \Delta f < 1 \text{ MHz}$	$0,215 \text{ MHz} \leq f_{\text{offset}} < 1,015 \text{ MHz}$	$-12,2 \text{ dBm} - 15 \cdot \left(\frac{f_{\text{offset}}}{\text{MHz}} - 0,215 \right) \text{ dB}$	30 kHz
(note 1)	$1,015 \text{ MHz} \leq f_{\text{offset}} < 1,5 \text{ MHz}$	-24,2 dBm	30 kHz
$1 \text{ MHz} \leq \Delta f \leq \min(\Delta f_{\text{max}}, 10 \text{ MHz})$	$1,5 \text{ MHz} \leq f_{\text{offset}} < \min(f_{\text{offset}_{\text{max}}}, 10,5 \text{ MHz})$	-11,2 dBm	1 MHz
$10 \text{ MHz} \leq \Delta f \leq \Delta f_{\text{max}}$	$10,5 \text{ MHz} \leq f_{\text{offset}} < f_{\text{offset}_{\text{max}}}$	-15 dBm (note 2)	1 MHz

NOTE 1: This frequency range ensures that the range of values of f_{offset} is continuous.

NOTE 2: The requirement is not applicable when $\Delta f_{\text{max}} < \Delta f_{\text{OBUE}}$.

NOTE 3: For MSR BS supporting non-contiguous spectrum operation within any operating band the test requirement within sub-block gaps is calculated as a cumulative sum of contributions from adjacent sub-blocks on each side of the sub-block gap, where the contribution from the far-end sub-block shall be scaled according to the measurement bandwidth of the near-end sub-block. Exception is $\Delta f \geq 10 \text{ MHz}$ from both adjacent sub-blocks on each side of the sub-block gap, where the test requirement within sub-block gaps shall be -15 dBm/MHz.

NOTE 4: For MSR BS supporting multi-band operation with Inter RF bandwidth gap $< 2 \times \Delta f_{\text{OBUE}}$ the test requirement within the Inter RF bandwidth gaps is calculated as a cumulative sum of contributions from adjacent sub-blocks or Base Station RF Bandwidth on each side of the Inter RF bandwidth gap, where the contribution from the far-end sub-block or Base Station RF Bandwidth shall be scaled according to the measurement bandwidth of the near-end sub-block or Base Station RF Bandwidth.

**Table 4.2.2.1-2A: Wide Area operating band unwanted emission limits for operation in
BC1 bands $\leq 3 \text{ GHz}$ with standalone NB-IoT carrier adjacent to the Base Station RF Bandwidth edge**

Frequency offset of measurement filter -3 dB point, Δf	Frequency offset of measurement filter centre frequency, f_{offset}	Test requirement (see notes 1, 2, 3 and 4)	Measurement bandwidth
$0 \text{ MHz} \leq \Delta f < 0,05 \text{ MHz}$	$0,015 \text{ MHz} \leq f_{\text{offset}} < 0,065 \text{ MHz}$	$\text{Max}\left(6,5 \text{ dBm} - 60 \left(\frac{f_{\text{offset}}}{\text{MHz}} - 0,015 \right) \text{ dB} + X \text{ dB}, -12,5 \text{ dBm} \right)$	30 kHz
$0,05 \text{ MHz} \leq \Delta f < 0,15 \text{ MHz}$	$0,065 \text{ MHz} \leq f_{\text{offset}} < 0,165 \text{ MHz}$	$\text{Max}\left(3,5 \text{ dBm} - 160 \left(\frac{f_{\text{offset}}}{\text{MHz}} - 0,065 \right) \text{ dB} + X \text{ dB}, -12,5 \text{ dBm} \right)$	30 kHz

NOTE 1: The limits in this table only apply for operation with a standalone NB-IoT carrier adjacent to the Base Station RF Bandwidth edge.

NOTE 2: For MSR BS supporting non-contiguous spectrum operation within any operating band the minimum requirement within sub-block gaps is calculated as a cumulative sum of contributions from adjacent sub-blocks on each side of the sub-block gap.

NOTE 3: For MSR BS supporting multi-band operation with Inter RF Bandwidth gap $< 2 \times \Delta f_{\text{OBUE}}$ the minimum requirement within the Inter RF Bandwidth gaps is calculated as a cumulative sum of contributions from adjacent sub-blocks or RF Bandwidth on each side of the Inter RF Bandwidth gap.

NOTE 4: In case the carrier adjacent to the RF bandwidth edge is a standalone NB-IoT carrier, the value of $X = P_{\text{NB-IoTcarrier}} - 43$. In other cases, $X = 0$.

Table 4.2.2.1-2B: Wide Area operating band Unwanted Emission Mask (UEM) for BS supporting NR and neither supporting UTRA nor with a standalone NB-IoT carrier at the BS RF bandwidth edge in BC1 and BC3 bands below 1 GHz

Frequency offset of measurement filter -3 dB point, Δf	Frequency offset of measurement filter centre frequency, f_{offset}	Minimum requirement (see notes 1 and 2)	Measurement bandwidth
$0 \text{ MHz} \leq \Delta f < 5 \text{ MHz}$	$0,05 \text{ MHz} \leq f_{\text{offset}} < 5,05 \text{ MHz}$	$-5,5 \text{ dBm} - 7/5(f_{\text{offset}}/\text{MHz} - 0,05)\text{dB}$	100 kHz
$5 \text{ MHz} \leq \Delta f < \min(10 \text{ MHz}, \Delta f_{\text{max}})$	$5,05 \text{ MHz} \leq f_{\text{offset}} < \min(10,05 \text{ MHz}, f_{\text{offset}_{\text{max}}})$	-12,5 dBm	100 kHz
$10 \text{ MHz} \leq \Delta f \leq \Delta f_{\text{max}}$	$10,05 \text{ MHz} \leq f_{\text{offset}} < f_{\text{offset}_{\text{max}}}$	-16 dBm (note 3)	100 kHz
NOTE 1: For MSR BS supporting non-contiguous spectrum operation within any operating band, the minimum requirement within sub-block gaps is calculated as a cumulative sum of contributions from adjacent sub blocks on each side of the sub block gap, where the contribution from the far-end sub-block or RF Bandwidth shall be scaled according to the measurement bandwidth of the near-end sub-block or RF Bandwidth. Exception is $\Delta f \geq 10 \text{ MHz}$ from both adjacent sub blocks on each side of the sub-block gap, where the minimum requirement within sub-block gaps shall be -16 dBm/100 kHz.			
NOTE 2: For MSR BS supporting multi-band operation with Inter RF Bandwidth gap $< 2 \times \Delta f_{\text{OBUE}}$ the minimum requirement within the Inter RF Bandwidth gaps is calculated as a cumulative sum of contributions from adjacent sub-blocks or RF Bandwidth on each side of the Inter RF Bandwidth gap, where the contribution from the far-end sub-block or RF Bandwidth shall be scaled according to the measurement bandwidth of the near-end sub-block or RF Bandwidth.			
NOTE 3: The requirement is not applicable when $\Delta f_{\text{max}} < \Delta f_{\text{OBUE}}$.			

Table 4.2.2.1-2C: Wide Area operating band Unwanted Emission Mask (UEM) for BS supporting NR (except operation in Band 1, 7, 38 and 65) and neither supporting UTRA nor with a standalone NB-IoT carrier at the BS RF bandwidth edge in BC1 and BC3 bands above 1 GHz and $\leq 3 \text{ GHz}$

Frequency offset of measurement filter -3 dB point, Δf	Frequency offset of measurement filter centre frequency, f_{offset}	Minimum requirement (see notes 1 and 2)	Measurement bandwidth
$0 \text{ MHz} \leq \Delta f < 5 \text{ MHz}$	$0,05 \text{ MHz} \leq f_{\text{offset}} < 5,05 \text{ MHz}$	$-5,5 \text{ dBm} - 7/5(f_{\text{offset}}/\text{MHz} - 0,05)\text{dB}$	100 kHz
$5 \text{ MHz} \leq \Delta f < \min(10 \text{ MHz}, \Delta f_{\text{max}})$	$5,05 \text{ MHz} \leq f_{\text{offset}} < \min(10,05 \text{ MHz}, f_{\text{offset}_{\text{max}}})$	-12,5 dBm	100 kHz
$10 \text{ MHz} \leq \Delta f \leq \Delta f_{\text{max}}$	$10,5 \text{ MHz} \leq f_{\text{offset}} < f_{\text{offset}_{\text{max}}}$	-15 dBm (note 3)	1 MHz
NOTE 1: For MSR BS supporting non-contiguous spectrum operation within any operating band, the minimum requirement within sub-block gaps is calculated as a cumulative sum of contributions from adjacent sub blocks on each side of the sub block gap, where the contribution from the far-end sub-block shall be scaled according to the measurement bandwidth of the near-end sub-block. Exception is $\Delta f \geq 10 \text{ MHz}$ from both adjacent sub blocks on each side of the sub-block gap, where the minimum requirement within sub-block gaps shall be -15 dBm/1 MHz.			
NOTE 2: For MSR BS supporting multi-band operation with Inter RF Bandwidth gap $< 2 \times \Delta f_{\text{OBUE}}$ the minimum requirement within the Inter RF Bandwidth gaps is calculated as a cumulative sum of contributions from adjacent sub-blocks or RF Bandwidth on each side of the Inter RF Bandwidth gap, where the contribution from the far-end sub-block or RF Bandwidth shall be scaled according to the measurement bandwidth of the near-end sub-block or RF Bandwidth.			
NOTE 3: The requirement is not applicable when $\Delta f_{\text{max}} < \Delta f_{\text{OBUE}}$.			

Table 4.2.2.2.1-2D: Wide Area operating band Unwanted Emission Mask (UEM) for BS supporting NR and neither supporting UTRA nor with a standalone NB-IoT carrier at the BS RF bandwidth edge in BC1 and BC3 bands above 3 GHz

Frequency offset of measurement filter -3 dB point, Δf	Frequency offset of measurement filter centre frequency, f_{offset}	Minimum requirement (see notes 1 and 2)	Measurement bandwidth
$0 \text{ MHz} \leq \Delta f < 5 \text{ MHz}$	$0,05 \text{ MHz} \leq f_{\text{offset}} < 5,05 \text{ MHz}$	$-5,2 \text{ dBm} - 7/5(f_{\text{offset}}/\text{MHz} - 0,05)\text{dB}$	100 kHz
$5 \text{ MHz} \leq \Delta f < \min(10 \text{ MHz}, \Delta f_{\text{max}})$	$5,05 \text{ MHz} \leq f_{\text{offset}} < \min(10,05 \text{ MHz}, f_{\text{offset}_{\text{max}}})$	-12,2 dBm	100 kHz
$10 \text{ MHz} \leq \Delta f \leq \Delta f_{\text{max}}$	$10,5 \text{ MHz} \leq f_{\text{offset}} < f_{\text{offset}_{\text{max}}}$	-15 dBm (note 3)	1 MHz
NOTE 1: For MSR BS supporting non-contiguous spectrum operation within any operating band, the minimum requirement within sub-block gaps is calculated as a cumulative sum of contributions from adjacent sub blocks on each side of the sub block gap, where the contribution from the far-end sub-block shall be scaled according to the measurement bandwidth of the near-end sub-block. Exception is $\Delta f \geq 10 \text{ MHz}$ from both adjacent sub blocks on each side of the sub-block gap, where the minimum requirement within sub-block gaps shall be -15 dBm/1 MHz.			
NOTE 2: For MSR BS supporting multi-band operation with Inter RF Bandwidth gap $< 2 \times \Delta f_{\text{OBUE}}$ the minimum requirement within the Inter RF Bandwidth gaps is calculated as a cumulative sum of contributions from adjacent sub-blocks or RF Bandwidth on each side of the Inter RF Bandwidth gap, where the contribution from the far-end sub-block or RF Bandwidth shall be scaled according to the measurement bandwidth of the near-end sub-block or RF Bandwidth.			
NOTE 3: The requirement is not applicable when $\Delta f_{\text{max}} < \Delta f_{\text{OBUE}}$.			

Table 4.2.2.2.1-3: Medium Range BS operating band Unwanted Emission Mask (UEM) for BC1 for bands $\leq 3 \text{ GHz}$, BS maximum output power $31 < P_{\text{Rated,c}} \leq 38 \text{ dBm}$ for BS not supporting NR

Frequency offset of measurement filter -3 dB point, Δf	Frequency offset of measurement filter centre frequency, f_{offset}	Test requirement (see notes 3 and 4)	Measurement bandwidth
$0 \text{ MHz} \leq \Delta f < 0,6 \text{ MHz}$	$0,015 \text{ MHz} \leq f_{\text{offset}} < 0,615 \text{ MHz}$	$P_{\text{Rated,c}} - 56,5 \text{ dB} - \frac{7}{5} \left(\frac{f_{\text{offset}}}{\text{MHz}} - 0,015 \right) \text{ dB}$	30 kHz
$0,6 \text{ MHz} \leq \Delta f < 1 \text{ MHz}$	$0,615 \text{ MHz} \leq f_{\text{offset}} < 1,015 \text{ MHz}$	$P_{\text{Rated,c}} - 51,5 \text{ dB} - 15 \left(\frac{f_{\text{offset}}}{\text{MHz}} - 0,215 \right) \text{ dB}$	30 kHz
(note 1)	$1,015 \text{ MHz} \leq f_{\text{offset}} < 1,5 \text{ MHz}$	$P_{\text{Rated,c}} - 63,5 \text{ dB}$	30 kHz
$1 \text{ MHz} \leq \Delta f \leq 2,6 \text{ MHz}$	$1,5 \text{ MHz} \leq f_{\text{offset}} < 3,1 \text{ MHz}$	$P_{\text{Rated,c}} - 50,5 \text{ dB}$	1 MHz
$2,6 \text{ MHz} \leq \Delta f \leq 5 \text{ MHz}$	$3,1 \text{ MHz} \leq f_{\text{offset}} < 5,5 \text{ MHz}$	$\min(P_{\text{Rated,c}} - 50,5 \text{ dB}, -13,5 \text{ dBm})$	1 MHz
$5 \text{ MHz} \leq \Delta f \leq \min(\Delta f_{\text{max}}, 10 \text{ MHz})$	$5,5 \text{ MHz} \leq f_{\text{offset}} < \min(f_{\text{offset}_{\text{max}}}, 10,5 \text{ MHz})$	$P_{\text{Rated,c}} - 54,5 \text{ dB}$	1 MHz
$10 \text{ MHz} \leq \Delta f \leq \Delta f_{\text{max}}$	$10,5 \text{ MHz} \leq f_{\text{offset}} < f_{\text{offset}_{\text{max}}}$	$P_{\text{Rated,c}} - 56 \text{ dB}$ (note 2)	1 MHz
NOTE 1: This frequency range ensures that the range of values of f_{offset} is continuous.			
NOTE 2: The requirement is not applicable when $\Delta f_{\text{max}} < \Delta f_{\text{OBUE}}$.			
NOTE 3: For MSR BS supporting non-contiguous spectrum operation within any operating band the test requirement within sub-block gaps is calculated as a cumulative sum of contributions from adjacent sub-blocks on each side of the sub-block gap, where the contribution from the far-end sub-block shall be scaled according to the measurement bandwidth of the near-end sub-block. Exception is $\Delta f \geq 10 \text{ MHz}$ from both adjacent sub-blocks on each side of the sub-block gap, where the test requirement within sub-block gaps shall be $(P_{\text{Rated,c}} - 56 \text{ dB})/\text{MHz}$.			
NOTE 4: For MSR BS supporting multi-band operation with Inter RF bandwidth gap $< 2 \times \Delta f_{\text{OBUE}}$ the test requirement within the Inter RF bandwidth gaps is calculated as a cumulative sum of contributions from adjacent sub-blocks or Base Station RF Bandwidth on each side of the Inter RF bandwidth gap, where the contribution from the far-end sub-block or Base Station RF Bandwidth shall be scaled according to the measurement bandwidth of the near-end sub-block or Base Station RF Bandwidth.			
NOTE 5: For operation with a standalone NB-IoT carrier adjacent to the Base Station RF Bandwidth edge, the limits in table 4.2.2.2.1-4A apply for $0 \text{ MHz} \leq \Delta f < 0,15 \text{ MHz}$.			

Table 4.2.2.1-4: Medium Range BS operating band Unwanted Emission Mask (UEM) for BC1 for bands > 3 GHz, BS maximum output power $31 < P_{Rated,c} \leq 38$ dBm for BS not supporting NR

Frequency offset of measurement filter -3 dB point, Δf	Frequency offset of measurement filter centre frequency, f_{offset}	Test requirement (see notes 3 and 4)	Measurement bandwidth
$0 \text{ MHz} \leq \Delta f < 0,6 \text{ MHz}$	$0,015 \text{ MHz} \leq f_{offset} < 0,615 \text{ MHz}$	$P_{Rated,c} - 56,2 \text{ dB} - \frac{7}{5} \left(\frac{f_{offset}}{\text{MHz}} - 0,015 \right) \text{ dB}$	30 kHz
$0,6 \text{ MHz} \leq \Delta f < 1 \text{ MHz}$	$0,615 \text{ MHz} \leq f_{offset} < 1,015 \text{ MHz}$	$P_{Rated,c} - 51,2 \text{ dB} - 15 \left(\frac{f_{offset}}{\text{MHz}} - 0,215 \right) \text{ dB}$	30 kHz
(note 1)	$1,015 \text{ MHz} \leq f_{offset} < 1,5 \text{ MHz}$	$P_{Rated,c} - 63,2 \text{ dB}$	30 kHz
$1 \text{ MHz} \leq \Delta f \leq 2,6 \text{ MHz}$	$1,5 \text{ MHz} \leq f_{offset} < 3,1 \text{ MHz}$	$P_{Rated,c} - 50,2 \text{ dB}$	1 MHz
$2,6 \text{ MHz} \leq \Delta f \leq 5 \text{ MHz}$	$3,1 \text{ MHz} \leq f_{offset} < 5,5 \text{ MHz}$	$\min(P_{Rated,c} - 50,2 \text{ dB}, -13,2 \text{ dBm})$	1 MHz
$5 \text{ MHz} \leq \Delta f \leq \min(\Delta f_{max}, 10 \text{ MHz})$	$5,5 \text{ MHz} \leq f_{offset} < \min(f_{offset_{max}}, 10,5 \text{ MHz})$	$P_{Rated,c} - 54,2 \text{ dB}$	1 MHz
$10 \text{ MHz} \leq \Delta f \leq \Delta f_{max}$	$10,5 \text{ MHz} \leq f_{offset} < f_{offset_{max}}$	$P_{Rated,c} - 56 \text{ dB}$ (note 2)	1 MHz

NOTE 1: This frequency range ensures that the range of values of f_{offset} is continuous.

NOTE 2: The requirement is not applicable when $\Delta f_{max} < \Delta f_{OBUE}$.

NOTE 3: For MSR BS supporting non-contiguous spectrum operation within any operating band the test requirement within sub-block gaps is calculated as a cumulative sum of contributions from adjacent sub-blocks on each side of the sub-block gap, where the contribution from the far-end sub-block shall be scaled according to the measurement bandwidth of the near-end sub-block. Exception is $\Delta f \geq 10$ MHz from both adjacent sub-blocks on each side of the sub-block gap, where the test requirement within sub-block gaps shall be $(P_{Rated,c} - 56 \text{ dB})/\text{MHz}$.

NOTE 4: For MSR BS supporting multi-band operation with Inter RF bandwidth gap $< 2 \times \Delta f_{OBUE}$ the test requirement within the Inter RF bandwidth gaps is calculated as a cumulative sum of contributions from adjacent sub-blocks or Base Station RF Bandwidth on each side of the Inter RF bandwidth gap, where the contribution from the far-end sub-block or Base Station RF Bandwidth shall be scaled according to the measurement bandwidth of the near-end sub-block or Base Station RF Bandwidth.

Table 4.2.2.1-4A: Medium Range BS operating band Unwanted Emission Mask (UEM) for BC1 for bands ≤ 3 GHz with standalone NB-IoT carrier adjacent to the Base Station RF Bandwidth edge, BS maximum output power $31 < P_{Rated,c} \leq 38$ dBm

Frequency offset of measurement filter -3 dB point, Δf	Frequency offset of measurement filter centre frequency, f_{offset}	Test requirement (see notes 1, 2 and 3)	Measurement bandwidth
$0 \text{ MHz} \leq \Delta f < 0,05 \text{ MHz}$ (note 1)	$0,015 \text{ MHz} \leq f_{offset} < 0,065 \text{ MHz}$	$P_{Rated,c} - 36,5 \text{ dB} - 60 \left(\frac{f_{offset}}{\text{MHz}} - 0,015 \right) \text{ dB}$	30 kHz
$0,05 \text{ MHz} \leq \Delta f < 0,15 \text{ MHz}$	$0,065 \text{ MHz} \leq f_{offset} < 0,165 \text{ MHz}$	$P_{Rated,c} - 39,5 \text{ dB} - 160 \left(\frac{f_{offset}}{\text{MHz}} - 0,065 \right) \text{ dB}$	30 kHz

NOTE 1: The limits in this table only apply for operation with a standalone NB-IoT carrier adjacent to the Base Station RF Bandwidth edge.

NOTE 2: For MSR BS supporting non-contiguous spectrum operation within any operating band the minimum requirement within sub-block gaps is calculated as a cumulative sum of contributions from adjacent sub blocks on each side of the sub block gap.

NOTE 3: For MSR BS supporting multi-band operation with Inter RF Bandwidth gap $< 2 \times \Delta f_{OBUE}$ the minimum requirement within the Inter RF Bandwidth gaps is calculated as a cumulative sum of contributions from adjacent sub-blocks or RF Bandwidth on each side of the Inter RF Bandwidth gap.

**Table 4.2.2.1-4B: Medium Range BS operating band Unwanted Emission Mask (UEM)
for BS supporting NR and not supporting UTRA in BC1 bands ≤ 3 GHz,
BS maximum output power $31 < P_{\text{Rated,c}} \leq 38$ dBm**

Frequency offset of measurement filter -3 dB point, Δf	Frequency offset of measurement filter centre frequency, f_{offset}	Minimum requirement (see notes 1 and 2)	Measurement bandwidth
$0 \text{ MHz} \leq \Delta f < 5 \text{ MHz}$	$0,05 \text{ MHz} \leq f_{\text{offset}} < 5,05 \text{ MHz}$	$P_{\text{Rated,c}} - 51,5 \text{ dB} - 7/5(f_{\text{offset}}/\text{MHz} - 0,05)\text{dB}$	100 kHz
$5 \text{ MHz} \leq \Delta f < \min(10 \text{ MHz}, \Delta f_{\text{max}})$	$5,05 \text{ MHz} \leq f_{\text{offset}} < \min(10,05 \text{ MHz}, f_{\text{offset}_{\text{max}}})$	$P_{\text{Rated,c}} - 58,5 \text{ dB}$	100 kHz
$10 \text{ MHz} \leq \Delta f \leq \Delta f_{\text{max}}$	$10,05 \text{ MHz} \leq f_{\text{offset}} < f_{\text{offset}_{\text{max}}}$	$\text{Min}(P_{\text{Rated,c}} - 60 \text{ dB}, -25 \text{ dBm})$ (note 4)	100 kHz

NOTE 1: For MSR BS supporting non-contiguous spectrum operation within any operating band the minimum requirement within sub-block gaps is calculated as a cumulative sum of contributions from adjacent sub blocks on each side of the sub block gap, where the contribution from the far-end sub-block shall be scaled according to the measurement bandwidth of the near-end sub-block. Exception is $\Delta f \geq 10$ MHz from both adjacent sub blocks on each side of the sub-block gap, where the minimum requirement within sub-block gaps shall be $\text{Min}(P_{\text{Rated,c}} - 60 \text{ dB}, -25 \text{ dBm})/100 \text{ kHz}$.

NOTE 2: For MSR BS supporting multi-band operation with Inter RF Bandwidth gap $< 2 \times \Delta f_{\text{OBUE}}$ the minimum requirement within the Inter RF Bandwidth gaps is calculated as a cumulative sum of contributions from adjacent sub-blocks or RF Bandwidth on each side of the Inter RF Bandwidth gap, where the contribution from the far-end sub-block shall be scaled according to the measurement bandwidth of the near-end sub-block.

NOTE 3: For operation with a standalone NB-IoT carrier adjacent to the Base Station RF Bandwidth edge, the limits in table 4.2.2.1-4A apply for $0 \text{ MHz} \leq \Delta f < 0,15 \text{ MHz}$.

NOTE 4: The requirement is not applicable when $\Delta f_{\text{max}} < \Delta f_{\text{OBUE}}$.

**Table 4.2.2.1-4C: Medium Range BS operating band Unwanted Emission Mask (UEM)
for BS supporting NR and not supporting UTRA in BC1 bands > 3 GHz,
BS maximum output power $31 < P_{\text{Rated,c}} \leq 38$ dBm**

Frequency offset of measurement filter -3 dB point, Δf	Frequency offset of measurement filter centre frequency, f_{offset}	Minimum requirement (see notes 1 and 2)	Measurement bandwidth
$0 \text{ MHz} \leq \Delta f < 5 \text{ MHz}$	$0,05 \text{ MHz} \leq f_{\text{offset}} < 5,05 \text{ MHz}$	$P_{\text{Rated,c}} - 51,2 \text{ dB} - 7/5(f_{\text{offset}}/\text{MHz} - 0,05)\text{dB}$	100 kHz
$5 \text{ MHz} \leq \Delta f < \min(10 \text{ MHz}, \Delta f_{\text{max}})$	$5,05 \text{ MHz} \leq f_{\text{offset}} < \min(10,05 \text{ MHz}, f_{\text{offset}_{\text{max}}})$	$P_{\text{Rated,c}} - 58,2 \text{ dB}$	100 kHz
$10 \text{ MHz} \leq \Delta f \leq \Delta f_{\text{max}}$	$10,05 \text{ MHz} \leq f_{\text{offset}} < f_{\text{offset}_{\text{max}}}$	$\text{Min}(P_{\text{Rated,c}} - 60 \text{ dB}, -25 \text{ dBm})$ (note 3)	100 kHz

NOTE 1: For MSR BS supporting non-contiguous spectrum operation within any operating band the minimum requirement within sub-block gaps is calculated as a cumulative sum of contributions from adjacent sub blocks on each side of the sub block gap, where the contribution from the far-end sub-block shall be scaled according to the measurement bandwidth of the near-end sub-block. Exception is $\Delta f \geq 10$ MHz from both adjacent sub blocks on each side of the sub-block gap, where the minimum requirement within sub-block gaps shall be $\text{Min}(P_{\text{Rated,c}} - 60 \text{ dB}, -25 \text{ dBm})/100 \text{ kHz}$.

NOTE 2: For MSR BS supporting multi-band operation with Inter RF Bandwidth gap $< 2 \times \Delta f_{\text{OBUE}}$ the minimum requirement within the Inter RF Bandwidth gaps is calculated as a cumulative sum of contributions from adjacent sub-blocks or RF Bandwidth on each side of the Inter RF Bandwidth gap, where the contribution from the far-end sub-block shall be scaled according to the measurement bandwidth of the near-end sub-block.

NOTE 3: The requirement is not applicable when $\Delta f_{\text{max}} < \Delta f_{\text{OBUE}}$.

Table 4.2.2.1-5: Medium Range BS operating band Unwanted Emission Mask (UEM) for BC1 for bands ≤ 3 GHz, BS maximum output power $P_{\text{Rated,c}} \leq 31$ dBm for BS not supporting NR

Frequency offset of measurement filter -3 dB point, Δf	Frequency offset of measurement filter centre frequency, f_{offset}	Test requirement (see notes 3 and 4)	Measurement bandwidth
$0 \text{ MHz} \leq \Delta f < 0,6 \text{ MHz}$	$0,015 \text{ MHz} \leq f_{\text{offset}} < 0,615 \text{ MHz}$	$-25,5 \text{ dBm} - \frac{7}{5} \cdot \left(\frac{f_{\text{offset}}}{\text{MHz}} - 0,015 \right) \text{ dB}$	30 kHz
$0,6 \text{ MHz} \leq \Delta f < 1 \text{ MHz}$	$0,615 \text{ MHz} \leq f_{\text{offset}} < 1,015 \text{ MHz}$	$-20,5 \text{ dBm} - 15 \cdot \left(\frac{f_{\text{offset}}}{\text{MHz}} - 0,215 \right) \text{ dB}$	30 kHz
(note 1)	$1,015 \text{ MHz} \leq f_{\text{offset}} < 1,5 \text{ MHz}$	-32,5 dBm	30 kHz
$1 \text{ MHz} \leq \Delta f \leq 5 \text{ MHz}$	$1,5 \text{ MHz} \leq f_{\text{offset}} < 5,5 \text{ MHz}$	-19,5 dBm	1 MHz
$5 \text{ MHz} \leq \Delta f \leq \min(\Delta f_{\text{max}}, 10 \text{ MHz})$	$5,5 \text{ MHz} \leq f_{\text{offset}} < \min(f_{\text{offset}_{\text{max}}}, 10,5 \text{ MHz})$	-23,5 dBm	1 MHz
$10 \text{ MHz} \leq \Delta f \leq \Delta f_{\text{max}}$	$10,5 \text{ MHz} \leq f_{\text{offset}} < f_{\text{offset}_{\text{max}}}$	-25 dBm (note 2)	1 MHz

NOTE 1: This frequency range ensures that the range of values of f_{offset} is continuous.

NOTE 2: The requirement is not applicable when $\Delta f_{\text{max}} < \Delta f_{\text{OBUE}}$.

NOTE 3: For MSR BS supporting non-contiguous spectrum operation within any operating band the test requirement within sub-block gaps is calculated as a cumulative sum of contributions from adjacent sub-blocks on each side of the sub-block gap, where the contribution from the far-end sub-block shall be scaled according to the measurement bandwidth of the near-end sub-block. Exception is $\Delta f \geq 10$ MHz from both adjacent sub-blocks on each side of the sub-block gap, where the test requirement within sub-block gaps shall be -25 dBm/MHz.

NOTE 4: For MSR BS supporting multi-band operation with Inter RF bandwidth gap $< 2 \times \Delta f_{\text{OBUE}}$ the test requirement within the Inter RF bandwidth gaps is calculated as a cumulative sum of contributions from adjacent sub-blocks or Base Station RF Bandwidth on each side of the Inter RF bandwidth gap, where the contribution from the far-end sub-block or Base Station RF Bandwidth shall be scaled according to the measurement bandwidth of the near-end sub-block or Base Station RF Bandwidth.

NOTE 5: For operation with a standalone NB-IoT carrier adjacent to the Base Station RF Bandwidth edge, the limits in table 4.2.2.1-6A apply for $0 \text{ MHz} \leq \Delta f < 0,15 \text{ MHz}$.

Table 4.2.2.1-6: Medium Range BS operating band Unwanted Emission Mask (UEM) for BC1 for bands > 3 GHz, BS maximum output power $P_{\text{Rated,c}} \leq 31$ dBm for BS not supporting NR

Frequency offset of measurement filter -3 dB point, Δf	Frequency offset of measurement filter centre frequency, f_{offset}	Test requirement (see notes 3 and 4)	Measurement bandwidth
$0 \text{ MHz} \leq \Delta f < 0,6 \text{ MHz}$	$0,015 \text{ MHz} \leq f_{\text{offset}} < 0,615 \text{ MHz}$	$-25,2 \text{ dBm} - \frac{7}{5} \cdot \left(\frac{f_{\text{offset}}}{\text{MHz}} - 0,015 \right) \text{ dB}$	30 kHz
$0,6 \text{ MHz} \leq \Delta f < 1 \text{ MHz}$	$0,615 \text{ MHz} \leq f_{\text{offset}} < 1,015 \text{ MHz}$	$-20,2 \text{ dBm} - 15 \cdot \left(\frac{f_{\text{offset}}}{\text{MHz}} - 0,215 \right) \text{ dB}$	30 kHz
(note 1)	$1,015 \text{ MHz} \leq f_{\text{offset}} < 1,5 \text{ MHz}$	-32,2 dBm	30 kHz
$1 \text{ MHz} \leq \Delta f \leq 5 \text{ MHz}$	$1,5 \text{ MHz} \leq f_{\text{offset}} < 5,5 \text{ MHz}$	-19,2 dBm	1 MHz
$5 \text{ MHz} \leq \Delta f \leq \min(\Delta f_{\text{max}}, 10 \text{ MHz})$	$5,5 \text{ MHz} \leq f_{\text{offset}} < \min(f_{\text{offset}_{\text{max}}}, 10,5 \text{ MHz})$	-23,2 dBm	1 MHz
$10 \text{ MHz} \leq \Delta f \leq \Delta f_{\text{max}}$	$10,5 \text{ MHz} \leq f_{\text{offset}} < f_{\text{offset}_{\text{max}}}$	-25 dBm (note 2)	1 MHz

NOTE 1: This frequency range ensures that the range of values of f_{offset} is continuous.

NOTE 2: The requirement is not applicable when $\Delta f_{\text{max}} < \Delta f_{\text{OBUE}}$.

NOTE 3: For MSR BS supporting non-contiguous spectrum operation within any operating band the test requirement within sub-block gaps is calculated as a cumulative sum of contributions from adjacent sub-blocks on each side of the sub-block gap, where the contribution from the far-end sub-block shall be scaled according to the measurement bandwidth of the near-end sub-block. Exception is $\Delta f \geq 10$ MHz from both adjacent sub-blocks on each side of the sub-block gap, where the test requirement within sub-block gaps shall be -25 dBm/MHz.

NOTE 4: For MSR BS supporting multi-band operation with Inter RF bandwidth gap $< 2 \times \Delta f_{\text{OBUE}}$ the test requirement within the Inter RF bandwidth gaps is calculated as a cumulative sum of contributions from adjacent sub-blocks or Base Station RF Bandwidth on each side of the Inter RF bandwidth gap, where the contribution from the far-end sub-block or Base Station RF Bandwidth shall be scaled according to the measurement bandwidth of the near-end sub-block or Base Station RF Bandwidth.

Table 4.2.2.2.1-6A: Medium Range BS operating band Unwanted Emission Mask (UEM) for BC1 for bands ≤ 3 GHz with standalone NB-IoT carrier adjacent to the Base Station RF Bandwidth edge, BS maximum output power $P_{\text{Rated,c}} \leq 31$ dBm

Frequency offset of measurement filter -3 dB point, Δf	Frequency offset of measurement filter centre frequency, f_{offset}	Test requirement (see notes 1, 2, 3 and 4)	Measurement bandwidth
$0 \text{ MHz} \leq \Delta f < 0,05 \text{ MHz}$ (note 1)	$0,015 \text{ MHz} \leq f_{\text{offset}} < 0,065 \text{ MHz}$	$Max(-5,5 \text{ dBm} - 60 \cdot \left(\frac{f_{\text{offset}}}{\text{MHz}} - 0,015\right) \text{ dB} + X \text{ dB}, -25,5 \text{ dBm})$	30 kHz
$0,05 \text{ MHz} \leq \Delta f < 0,15 \text{ MHz}$	$0,065 \text{ MHz} \leq f_{\text{offset}} < 0,165 \text{ MHz}$	$Max(-8,5 \text{ dBm} - 160 \cdot \left(\frac{f_{\text{offset}}}{\text{MHz}} - 0,065\right) \text{ dB} + X \text{ dB}, -25,5 \text{ dBm})$	30 kHz

NOTE 1: The limits in this table only apply for operation with a standalone NB-IoT carrier adjacent to the Base Station RF Bandwidth edge.

NOTE 2: For MSR BS supporting non-contiguous spectrum operation within any operating band the minimum requirement within sub-block gaps is calculated as a cumulative sum of contributions from adjacent sub blocks on each side of the sub block gap.

NOTE 3: For MSR BS supporting multi-band operation with Inter RF Bandwidth gap $< 2 \times \Delta f_{\text{OBUE}}$ the minimum requirement within the Inter RF Bandwidth gaps is calculated as a cumulative sum of contributions from adjacent sub-blocks or RF Bandwidth on each side of the Inter RF Bandwidth gap.

NOTE 4: In case the carrier adjacent to the RF bandwidth edge is a standalone NB-IoT carrier, the value of $X = P_{\text{NB-IoTcarrier}} - 31$, where $P_{\text{NB-IoTcarrier}}$ is the power level of the standalone NB-IoT carrier adjacent to the RF bandwidth edge. In other cases, $X = 0$.

Table 4.2.2.2.1-6B: Medium Range BS operating band Unwanted Emission Mask (UEM) for BS supporting NR and not supporting UTRA in BC1 bands ≤ 3 GHz, BS maximum output power $P_{\text{Rated,c}} \leq 31$ dBm

Frequency offset of measurement filter -3 dB point, Δf	Frequency offset of measurement filter centre frequency, f_{offset}	Minimum requirement (see notes 1 and 2)	Measurement bandwidth
$0 \text{ MHz} \leq \Delta f < 5 \text{ MHz}$	$0,05 \text{ MHz} \leq f_{\text{offset}} < 5,05 \text{ MHz}$	$-20,5 \text{ dBm} - 7/5(f_{\text{offset}}/\text{MHz} - 0,05) \text{ dB}$	100 kHz
$5 \text{ MHz} \leq \Delta f < \min(10 \text{ MHz}, \Delta f_{\text{max}})$	$5,05 \text{ MHz} \leq f_{\text{offset}} < \min(10,05 \text{ MHz}, f_{\text{offset}_{\text{max}}})$	-27,5 dBm	100 kHz
$10 \text{ MHz} \leq \Delta f \leq \Delta f_{\text{max}}$	$10,05 \text{ MHz} \leq f_{\text{offset}} < f_{\text{offset}_{\text{max}}}$	-29 dBm (note 4)	100 kHz

NOTE 1: For MSR BS supporting non-contiguous spectrum operation within any operating band the minimum requirement within sub-block gaps is calculated as a cumulative sum of contributions from adjacent sub blocks on each side of the sub block gap, where the contribution from the far-end sub-block shall be scaled according to the measurement bandwidth of the near-end sub-block. Exception is $\Delta f \geq 10$ MHz from both adjacent sub blocks on each side of the sub-block gap, where the minimum requirement within sub-block gaps shall be -29 dBm/100 kHz.

NOTE 2: For MSR BS supporting multi-band operation with Inter RF Bandwidth gap $< 2 \times \Delta f_{\text{OBUE}}$ the minimum requirement within the Inter RF Bandwidth gaps is calculated as a cumulative sum of contributions from adjacent sub-blocks or RF Bandwidth on each side of the Inter RF Bandwidth gap, where the contribution from the far-end sub-block shall be scaled according to the measurement bandwidth of the near-end sub-block.

NOTE 3: For operation with a standalone NB-IoT carrier adjacent to the Base Station RF Bandwidth edge, the limits in table 4.2.2.2.1-6A apply for $0 \text{ MHz} \leq \Delta f < 0,15 \text{ MHz}$.

NOTE 4: The requirement is not applicable when $\Delta f_{\text{max}} < \Delta f_{\text{OBUE}}$.

**Table 4.2.2.2.1-6C: Medium Range BS operating band Unwanted Emission Mask (UEM)
for BS supporting NR and not supporting UTRA in BC1 bands > 3 GHz,
BS maximum output power $P_{\text{Rated,c}} \leq 31$ dBm**

Frequency offset of measurement filter -3 dB point, Δf	Frequency offset of measurement filter centre frequency, f_{offset}	Minimum requirement (see notes 1 and 2)	Measurement bandwidth
$0 \text{ MHz} \leq \Delta f < 5 \text{ MHz}$	$0,05 \text{ MHz} \leq f_{\text{offset}} < 5,05 \text{ MHz}$	- 20,2 dBm - $7/5(f_{\text{offset}}/\text{MHz} - 0,05)\text{dB}$	100 kHz
$5 \text{ MHz} \leq \Delta f < \min(10 \text{ MHz}, \Delta f_{\text{max}})$	$5,05 \text{ MHz} \leq f_{\text{offset}} < \min(10,05 \text{ MHz}, f_{\text{offset}_{\text{max}}})$	-27,2 dBm	100 kHz
$10 \text{ MHz} \leq \Delta f \leq \Delta f_{\text{max}}$	$10,05 \text{ MHz} \leq f_{\text{offset}} < f_{\text{offset}_{\text{max}}}$	-29 dBm (note 3)	100 kHz

NOTE 1: For MSR BS supporting non-contiguous spectrum operation within any operating band the minimum requirement within sub-block gaps is calculated as a cumulative sum of contributions from adjacent sub blocks on each side of the sub block gap, where the contribution from the far-end sub-block shall be scaled according to the measurement bandwidth of the near-end sub-block. Exception is $\Delta f \geq 10$ MHz from both adjacent sub blocks on each side of the sub-block gap, where the minimum requirement within sub-block gaps shall be -29 dBm/100 kHz.

NOTE 2: For MSR BS supporting multi-band operation with Inter RF Bandwidth gap $< 2 \times \Delta f_{\text{OBUE}}$ the minimum requirement within the Inter RF Bandwidth gaps is calculated as a cumulative sum of contributions from adjacent sub-blocks or RF Bandwidth on each side of the Inter RF Bandwidth gap, where the contribution from the far-end sub-block shall be scaled according to the measurement bandwidth of the near-end sub-block.

NOTE 3: The requirement is not applicable when $\Delta f_{\text{max}} < \Delta f_{\text{OBUE}}$.

**Table 4.2.2.2.1-7: Local Area operating band Unwanted Emission Mask (UEM)
for BC1 for bands ≤ 3 GHz**

Frequency offset of measurement filter -3 dB point, Δf	Frequency offset of measurement filter centre frequency, f_{offset}	Test requirement (see notes 2 and 3)	Measurement bandwidth
$0 \text{ MHz} \leq \Delta f < 5 \text{ MHz}$	$0,05 \text{ MHz} \leq f_{\text{offset}} < 5,05 \text{ MHz}$	$-28,5 \text{ dBm} - \frac{7}{5} \left(\frac{f_{\text{offset}}}{\text{MHz}} - 0,05 \right) \text{ dB}$	100 kHz
$5 \text{ MHz} \leq \Delta f < \min(10 \text{ MHz}, \Delta f_{\text{max}})$	$5,05 \text{ MHz} \leq f_{\text{offset}} < \min(10,05 \text{ MHz}, f_{\text{offset}_{\text{max}}})$	-35,5 dBm	100 kHz
$10 \text{ MHz} \leq \Delta f \leq \Delta f_{\text{max}}$	$10,05 \text{ MHz} \leq f_{\text{offset}} < f_{\text{offset}_{\text{max}}}$	-37 dBm (note 1)	100 kHz

NOTE 1: The requirement is not applicable when $\Delta f_{\text{max}} < \Delta f_{\text{OBUE}}$.

NOTE 2: For MSR BS supporting non-contiguous spectrum operation within any operating band the test requirement within sub-block gaps is calculated as a cumulative sum of contributions from adjacent sub-blocks on each side of the sub-block gap. Exception is $\Delta f \geq 10$ MHz from both adjacent sub-blocks on each side of the sub-block gap, where the test requirement within sub-block gaps shall be -37 dBm/100 kHz.

NOTE 3: For MSR BS supporting multi-band operation with Inter RF bandwidth gap $< 2 \times \Delta f_{\text{OBUE}}$ the test requirement within the Inter RF bandwidth gaps is calculated as a cumulative sum of contributions from adjacent sub-blocks or Base Station RF Bandwidth on each side of the Inter RF bandwidth gap.

NOTE 4: For operation with a standalone NB-IoT carrier adjacent to the Base Station RF Bandwidth edge, the limits in table 4.2.2.2.1-9 apply for $0 \text{ MHz} \leq \Delta f < 0,15 \text{ MHz}$.

Table 4.2.2.2.1-8: Local Area operating band Unwanted Emission Mask (UEM) for BC1 for bands > 3 GHz

Frequency offset of measurement filter -3 dB point, Δf	Frequency offset of measurement filter centre frequency, f_{offset}	Test requirement (see notes 2 and 3)	Measurement bandwidth
$0 \text{ MHz} \leq \Delta f < 5 \text{ MHz}$	$0,05 \text{ MHz} \leq f_{\text{offset}} < 5,05 \text{ MHz}$	$-28,2 \text{ dBm} - \frac{7}{5} \left(\frac{f_{\text{offset}}}{\text{MHz}} - 0,05 \right) \text{ dB}$	100 kHz
$5 \text{ MHz} \leq \Delta f < \min(10 \text{ MHz}, \Delta f_{\text{max}})$	$5,05 \text{ MHz} \leq f_{\text{offset}} < \min(10,05 \text{ MHz}, f_{\text{offset}_{\text{max}}})$	-35,2 dBm	100 kHz
$10 \text{ MHz} \leq \Delta f \leq \Delta f_{\text{max}}$	$10,05 \text{ MHz} \leq f_{\text{offset}} < f_{\text{offset}_{\text{max}}}$	-37 dBm (note 1)	100 kHz

NOTE 1: The requirement is not applicable when $\Delta f_{\text{max}} < \Delta f_{\text{OBUe}}$.

NOTE 2: For MSR BS supporting non-contiguous spectrum operation within any operating band the test requirement within sub-block gaps is calculated as a cumulative sum of contributions from adjacent sub-blocks on each side of the sub-block gap. Exception is $\Delta f \geq 10 \text{ MHz}$ from both adjacent sub-blocks on each side of the sub-block gap, where the test requirement within sub-block gaps shall be -37 dBm/100 kHz.

NOTE 3: For MSR BS supporting multi-band operation with Inter RF bandwidth gap $< 2 \times \Delta f_{\text{OBUe}}$ the test requirement within the Inter RF bandwidth gaps is calculated as a cumulative sum of contributions from adjacent sub-blocks or Base Station RF Bandwidth on each side of the Inter RF bandwidth gap.

Table 4.2.2.2.1-9: Local Area operating band Unwanted Emission Mask (UEM) for BC1 for bands $\leq 3 \text{ GHz}$ with standalone NB-IoT carrier adjacent to the Base Station RF Bandwidth edge

Frequency offset of measurement filter -3 dB point, Δf	Frequency offset of measurement filter centre frequency, f_{offset}	Test requirement (see notes 1, 2, 3 and 4)	Measurement bandwidth
$0 \text{ MHz} \leq \Delta f < 0,05 \text{ MHz}$ (note 1)	$0,015 \text{ MHz} \leq f_{\text{offset}} < 0,065 \text{ MHz}$	$\text{Max}(-12,5 \text{ dBm} - 60 \cdot \left(\frac{f_{\text{offset}}}{\text{MHz}} - 0,015 \right) \text{ dB} + X \text{ dB}, -33,5 \text{ dBm})$	30 kHz
$0,05 \text{ MHz} \leq \Delta f < 0,16 \text{ MHz}$	$0,065 \text{ MHz} \leq f_{\text{offset}} < 0,175 \text{ MHz}$	$\text{Max}(-15,5 \text{ dBm} - 160 \cdot \left(\frac{f_{\text{offset}}}{\text{MHz}} - 0,065 \right) \text{ dB} + X \text{ dB}, -33,5 \text{ dBm})$	30 kHz

NOTE 1: The limits in this table only apply for operation with a standalone NB-IoT carrier adjacent to the Base Station RF Bandwidth edge.

NOTE 2: For MSR BS supporting non-contiguous spectrum operation within any operating band the minimum requirement within sub-block gaps is calculated as a cumulative sum of contributions from adjacent sub blocks on each side of the sub block gap.

NOTE 3: For MSR BS supporting multi-band operation with Inter RF Bandwidth gap $< 2 \times \Delta f_{\text{OBUe}}$ the minimum requirement within the Inter RF Bandwidth gaps is calculated as a cumulative sum of contributions from adjacent sub-blocks or RF Bandwidth on each side of the Inter RF Bandwidth gap.

NOTE 4: In case the carrier adjacent to the RF bandwidth edge is a standalone NB-IoT carrier, the value of $X = P_{\text{NB-IoTcarrier}} - 24$, where $P_{\text{NB-IoTcarrier}}$ is the power level of the standalone NB-IoT carrier adjacent to the RF bandwidth edge. In other cases, $X = 0$.

4.2.2.2.2 Limits for Band Category 2

For a BS operating in Band Category 2 the requirement shall apply outside the Base Station RF bandwidth edges. In addition, for a BS operating in non-contiguous spectrum, it shall apply inside any sub-block gap.

Outside the Base Station RF bandwidth edges, emissions shall not exceed the maximum levels specified in tables 4.2.2.2.2-1 to 4.2.2.2.2-8, where:

- Δf is the separation between the Base Station RF bandwidth edge frequency and the nominal -3 dB point of the measuring filter closest to the carrier frequency.
- f_{offset} is the separation between the Base Station RF bandwidth edge frequency and the centre of the measuring filter.
- $f_{\text{offset}_{\text{max}}}$ is the offset to the frequency Δf_{OBUe} outside the downlink operating band.

- Δf_{\max} is equal to $f_{\text{offset}_{\max}}$ minus half of the bandwidth of the measuring filter.

For a BS operating in multiple bands, inside any inter-RF bandwidth gaps with $W_{\text{gap}} < 2 \times \Delta f_{\text{OBUE}}$, emissions shall not exceed the cumulative sum of the test requirements specified at the Base Station RF bandwidth edges on each side of the inter-RF bandwidth gap. The test requirement for Base Station RF bandwidth edge is specified in tables 4.2.2.2.2-1 to 4.2.2.2.2-8, where in this case:

- Δf is the separation between the Base Station RF bandwidth edge frequency and the nominal -3 dB point of the measuring filter closest to the carrier frequency.
- f_{offset} is the separation between the Base Station RF bandwidth edge frequency and the centre of the measuring filter.
- $f_{\text{offset}_{\max}}$ is equal to the Inter RF bandwidth gap minus half of the bandwidth of the measuring filter.
- Δf_{\max} is equal to $f_{\text{offset}_{\max}}$ minus half of the bandwidth of the measuring filter.

For a BS capable of multi-band operation where multiple bands are mapped on the same antenna connector and where there is no carrier transmitted in an operating band, the operating band unwanted emission limit, as defined in the tables of the present clause for the largest frequency offset (Δf_{\max}), of a band where there are no carriers transmitted shall apply from Δf_{OBUE} below the lowest frequency, up to Δf_{OBUE} above the highest frequency of the supported downlink operating band without any carrier transmitted; and no cumulative limits are applied in the inter-band gap between a supported downlink band with carrier(s) transmitted and a supported downlink band without any carrier transmitted.

Inside any sub-block gap for a BS operating in non-contiguous spectrum, emissions shall not exceed the cumulative sum of the test requirement specified for the adjacent sub-blocks on each side of the sub-block gap. The test requirement for each sub-block is specified in tables 4.2.2.2.2-1 to 4.2.2.2.2-8, where in this case:

- Δf is the separation between the sub-block edge frequency and the nominal -3 dB point of the measuring filter closest to the sub-block edge.
- f_{offset} is the separation between the sub-block edge frequency and the centre of the measuring filter.
- $f_{\text{offset}_{\max}}$ is equal to the sub-block gap bandwidth minus half of the bandwidth of the measuring filter.
- Δf_{\max} is equal to $f_{\text{offset}_{\max}}$ minus half of the bandwidth of the measuring filter.

Applicability of Wide Area operating band unwanted emission requirements in tables 4.2.2.2.2-1, 4.2.2.2.2-2A and 4.2.2.2.2-2B is specified in table 4.2.2.2.2-0.

Table 4.2.2.2-0: Applicability of operating band unwanted emission requirements for BC2 Wide Area BS

NR Band operation	Standalone NB-IoT carrier adjacent to the BS RF bandwidth edge	UTRA or GSM supported (note)	Applicable requirement table
None	Y/N	Y/N	4.2.2.2.2-1
Bands 3 and 8	N	N	4.2.2.2.2-1
Any	Y	N	4.2.2.2.2-1
Any below 1 GHz except for band 8	N	N	4.2.2.2.2-2A
Any above 1 GHz except for band 3	N	N	4.2.2.2.2-2B
NOTE: NR operation with UTRA or GSM is not supported in the present document.			

**Table 4.2.2.2-1: Wide Area BS operating band Unwanted Emission Mask (UEM)
for BC2 for BS not supporting NR (except for BS operating in Band 3 or 8) or
(irrespective of NR support) BS with standalone NB-IoT at the BS RF bandwidth edge**

Frequency offset of measurement filter -3 dB point, Δf	Frequency offset of measurement filter centre frequency, f_{offset}	Test requirement (see notes 4 and 5)	Measurement bandwidth
$0 \text{ MHz} \leq \Delta f < 0,2 \text{ MHz}$ (note 1)	$0,015 \text{ MHz} \leq f_{\text{offset}} < 0,215 \text{ MHz}$	-12,5 dBm	30 kHz
$0,2 \text{ MHz} \leq \Delta f < 1 \text{ MHz}$ (note 2)	$0,215 \text{ MHz} \leq f_{\text{offset}} < 1,015 \text{ MHz}$ $1,015 \text{ MHz} \leq f_{\text{offset}} < 1,5 \text{ MHz}$	$-12,5 \text{ dBm} - 15 \cdot \left(\frac{f_{\text{offset}}}{\text{MHz}} - 0,215 \right) \text{ dB}$ (note 6)	30 kHz
$1 \text{ MHz} \leq \Delta f \leq \min(\Delta f_{\text{max}}, 10 \text{ MHz})$	$1,5 \text{ MHz} \leq f_{\text{offset}} < \min(f_{\text{offset}_{\text{max}}}, 10,5 \text{ MHz})$	-11,5 dBm (note 6)	1 MHz
$10 \text{ MHz} \leq \Delta f \leq \Delta f_{\text{max}}$	$10,5 \text{ MHz} \leq f_{\text{offset}} < f_{\text{offset}_{\text{max}}}$	-15 dBm (notes 3 and 6)	1 MHz
<p>NOTE 1: For operation with a GSM/EDGE or an E-UTRA 1,4 MHz or 3 MHz carrier adjacent to the Base Station RF bandwidth edge, the limits in table 4.2.2.2-2 shall apply for $0 \text{ MHz} \leq \Delta f < 0,15 \text{ MHz}$.</p> <p>NOTE 2: This frequency range ensures that the range of values of f_{offset} is continuous.</p> <p>NOTE 3: The requirement is not applicable when $\Delta f_{\text{max}} < \Delta f_{\text{OBUE}}$.</p> <p>NOTE 4: For MSR BS supporting non-contiguous spectrum operation within any operating band the test requirement within sub-block gaps is calculated as a cumulative sum of contributions from adjacent sub-blocks on each side of the sub-block gap, where the contribution from the far-end sub-block shall be scaled according to the measurement bandwidth of the near-end sub-block. Exception is $\Delta f \geq 10 \text{ MHz}$ from both adjacent sub-blocks on each side of the sub-block gap, where the test requirement within sub-block gaps shall be -15 dBm/MHz. (for MSR BS supporting multi-band operation, either this limit or -16 dBm/100 kHz with correspondingly adjusted f_{offset} shall apply for this frequency offset range for operating bands < 1 GHz).</p> <p>NOTE 5: For MSR BS supporting multi-band operation with Inter RF bandwidth gap < $2 \times \Delta f_{\text{OBUE}}$ operation the test requirement within the Inter RF bandwidth gaps is calculated as a cumulative sum of contributions from adjacent sub-blocks or Base Station RF Bandwidth on each side of the Inter RF bandwidth gap, where the contribution from the far-end sub-block or Base Station RF Bandwidth shall be scaled according to the measurement bandwidth of the near-end sub-block or Base Station RF Bandwidth.</p> <p>NOTE 6: For MSR BS supporting multi-band operation, either this limit or -16 dBm/100 kHz with correspondingly adjusted f_{offset} shall apply for this frequency offset range for operating bands < 1 GHz.</p>			

Table 4.2.2.2-2: Wide Area BS operating band unwanted emission limits for operation in BC2 with GSM/EDGE or standalone NB-IoT or E-UTRA 1,4 MHz or 3 MHz carriers adjacent to the RF bandwidth edge

Frequency offset of measurement filter -3 dB point, Δf	Frequency offset of measurement filter centre frequency, f_{offset}	Test requirement (see notes 2, 3, 4 and 5)	Measurement bandwidth
$0 \text{ MHz} \leq \Delta f < 0,05 \text{ MHz}$	$0,015 \text{ MHz} \leq f_{\text{offset}} < 0,065 \text{ MHz}$	$\text{Max}(6,5 \text{ dBm} - 60 \cdot \left(\frac{f_{\text{offset}}}{\text{MHz}} - 0,015 \right) \text{ dB} + X \text{ dB}, -12,5 \text{ dBm})$	30 kHz
$0,05 \text{ MHz} \leq \Delta f < 0,15 \text{ MHz}$	$0,065 \text{ MHz} \leq f_{\text{offset}} < 0,165 \text{ MHz}$	$\text{Max}(3,5 \text{ dBm} - 160 \cdot \left(\frac{f_{\text{offset}}}{\text{MHz}} - 0,065 \right) \text{ dB} + X \text{ dB}, -12,5 \text{ dBm})$	30 kHz

NOTE 1: The limits in this table only shall apply for operation with a GSM/EDGE or standalone NB-IoT or an E-UTRA 1,4 MHz or 3 MHz carrier adjacent to the Base Station RF bandwidth edge.

NOTE 2: For MSR BS supporting non-contiguous spectrum operation within any operating band the test requirement within sub-block gaps is calculated as a cumulative sum of contributions from adjacent sub-blocks on each side of the sub-block gap.

NOTE 3: In case the carrier adjacent to the Base Station RF bandwidth edge is a GSM/EDGE carrier, the value of $X = P_{\text{GSMcarrier}} - 43$, where $P_{\text{GSMcarrier}}$ is the power level of the GSM/EDGE carrier adjacent to the Base Station RF bandwidth edge. In other cases, $X = 0$.

NOTE 4: For MSR BS supporting multi-band operation with Inter RF bandwidth gap $< 2 \times \Delta f_{\text{OBUE}}$ operation the test requirement within the Inter RF bandwidth gaps is calculated as a cumulative sum of contributions from adjacent sub-blocks or Base Station RF Bandwidth on each side of the Inter RF bandwidth gap.

NOTE 5: In case the carrier adjacent to the RF bandwidth edge is a NB-IoT carrier, the value of $X = P_{\text{NB-IoTcarrier}} - 43$. In other cases, $X = 0$.

Table 4.2.2.2-2A: Wide Area operating band Unwanted Emission Mask (UEM) for BS supporting NR (except operation in Band 8) and neither supporting UTRA nor GSM nor with a standalone NB-IoT carrier at the BS RF bandwidth edge in BC2 bands below 1 GHz

Frequency offset of measurement filter -3 dB point, Δf	Frequency offset of measurement filter centre frequency, f_{offset}	Minimum requirement (see notes 1 and 2)	Measurement bandwidth
$0 \text{ MHz} \leq \Delta f < 5 \text{ MHz}$	$0,05 \text{ MHz} \leq f_{\text{offset}} < 5,05 \text{ MHz}$	$-5,5 \text{ dBm} - 7/5(f_{\text{offset}}/\text{MHz} - 0,05) \text{ dB}$	100 kHz
$5 \text{ MHz} \leq \Delta f < \min(10 \text{ MHz}, \Delta f_{\text{max}})$	$5,05 \text{ MHz} \leq f_{\text{offset}} < \min(10,05 \text{ MHz}, f_{\text{offset}_{\text{max}}})$	-12,5 dBm	100 kHz
$10 \text{ MHz} \leq \Delta f \leq \Delta f_{\text{max}}$	$10,05 \text{ MHz} \leq f_{\text{offset}} < f_{\text{offset}_{\text{max}}}$	-16 dBm (note 4)	100 kHz

NOTE 1: For MSR BS supporting non-contiguous spectrum operation within any operating band, the minimum requirement within sub-block gaps is calculated as a cumulative sum of contributions from adjacent sub blocks on each side of the sub block gap, where the contribution from the far-end sub-block or RF Bandwidth shall be scaled according to the measurement bandwidth of the near-end sub-block or RF Bandwidth. Exception is $\Delta f \geq 10 \text{ MHz}$ from both adjacent sub blocks on each side of the sub-block gap, where the minimum requirement within sub-block gaps shall be -16 dBm/100 kHz.

NOTE 2: For MSR BS supporting multi-band operation with Inter RF Bandwidth gap $< 2 \times \Delta f_{\text{OBUE}}$ the minimum requirement within the Inter RF Bandwidth gaps is calculated as a cumulative sum of contributions from adjacent sub-blocks or RF Bandwidth on each side of the Inter RF Bandwidth gap, where the contribution from the far-end sub-block or RF Bandwidth shall be scaled according to the measurement bandwidth of the near-end sub-block or RF Bandwidth.

NOTE 3: For operation with an E-UTRA 1,4 or 3 MHz carrier adjacent to the Base Station RF Bandwidth edge, the limits in table 4.2.2.2-2 apply for $0 \text{ MHz} \leq \Delta f < 0,15 \text{ MHz}$.

NOTE 4: The requirement is not applicable when $\Delta f_{\text{max}} < \Delta f_{\text{OBUE}}$.

Table 4.2.2.2-2B: Wide Area operating band Unwanted Emission Mask (UEM) for BS supporting NR (except operation in Band 3) and neither supporting UTRA nor GSM nor with a standalone NB-IoT carrier at the BS RF bandwidth edge in BC2 bands above 1 GHz

Frequency offset of measurement filter -3 dB point, Δf	Frequency offset of measurement filter centre frequency, f_{offset}	Minimum requirement (see notes 1 and 2)	Measurement bandwidth
$0 \text{ MHz} \leq \Delta f < 5 \text{ MHz}$	$0,05 \text{ MHz} \leq f_{\text{offset}} < 5,05 \text{ MHz}$	$-5,5 \text{ dBm} - 7/5(f_{\text{offset}}/\text{MHz} - 0,05)\text{dB}$	100 kHz
$5 \text{ MHz} \leq \Delta f < \min(10 \text{ MHz}, \Delta f_{\text{max}})$	$5,05 \text{ MHz} \leq f_{\text{offset}} < \min(10,05 \text{ MHz}, f_{\text{offset}_{\text{max}}})$	-12,5 dBm	100 kHz
$10 \text{ MHz} \leq \Delta f \leq \Delta f_{\text{max}}$	$10,5 \text{ MHz} \leq f_{\text{offset}} < f_{\text{offset}_{\text{max}}}$	-15 dBm (note 4)	1 MHz
NOTE 1: For MSR BS supporting non-contiguous spectrum operation within any operating band, the minimum requirement within sub-block gaps is calculated as a cumulative sum of contributions from adjacent sub blocks on each side of the sub block gap, where the contribution from the far-end sub-block shall be scaled according to the measurement bandwidth of the near-end sub-block. Exception is $\Delta f \geq 10 \text{ MHz}$ from both adjacent sub blocks on each side of the sub-block gap, where the minimum requirement within sub-block gaps shall be -15 dBm/1 MHz.			
NOTE 2: For MSR BS supporting multi-band operation with Inter RF Bandwidth gap $< 2 \times \Delta f_{\text{OBUE}}$ the minimum requirement within the Inter RF Bandwidth gaps is calculated as a cumulative sum of contributions from adjacent sub-blocks or RF Bandwidth on each side of the Inter RF Bandwidth gap, where the contribution from the far-end sub-block or RF Bandwidth shall be scaled according to the measurement bandwidth of the near-end sub-block or RF Bandwidth.			
NOTE 3: For operation with an E-UTRA 1,4 or 3 MHz carrier adjacent to the Base Station RF Bandwidth edge, the limits in table 4.2.2.2-2 apply for $0 \text{ MHz} \leq \Delta f < 0,15 \text{ MHz}$.			
NOTE 4: The requirement is not applicable when $\Delta f_{\text{max}} < \Delta f_{\text{OBUE}}$.			

Table 4.2.2.2-3: Medium Range BS operating band Unwanted Emission Mask (UEM) for BC2, BS maximum output power $31 < P_{\text{Rated,c}} \leq 38 \text{ dBm}$ for BS not supporting NR

Frequency offset of measurement filter -3 dB point, Δf	Frequency offset of measurement filter centre frequency, f_{offset}	Test requirement (see notes 4 and 5)	Measurement bandwidth
$0 \text{ MHz} \leq \Delta f < 0,6 \text{ MHz}$ (note 1)	$0,015 \text{ MHz} \leq f_{\text{offset}} < 0,615 \text{ MHz}$	$P_{\text{Rated,c}} - 56,5 \text{ dB} - \frac{7}{5} \left(\frac{f_{\text{offset}}}{\text{MHz}} - 0,015 \right) \text{ dB}$	30 kHz
$0,6 \text{ MHz} \leq \Delta f < 1 \text{ MHz}$ (note 2)	$0,615 \text{ MHz} \leq f_{\text{offset}} < 1,015 \text{ MHz}$ $1,015 \text{ MHz} \leq f_{\text{offset}} < 1,5 \text{ MHz}$	$P_{\text{Rated,c}} - 51,5 \text{ dB} - 15 \left(\frac{f_{\text{offset}}}{\text{MHz}} - 0,215 \right) \text{ dB}$ $P_{\text{Rated,c}} - 63,5 \text{ dB}$	30 kHz
$1 \text{ MHz} \leq \Delta f \leq 2,8 \text{ MHz}$	$1,5 \text{ MHz} \leq f_{\text{offset}} < 3,3 \text{ MHz}$	$P_{\text{Rated,c}} - 50,5 \text{ dB}$	1 MHz
$2,8 \text{ MHz} \leq \Delta f \leq 5 \text{ MHz}$	$3,3 \text{ MHz} \leq f_{\text{offset}} < 5,5 \text{ MHz}$	$\min(P_{\text{Rated,c}} - 50,5 \text{ dB}, -13,5 \text{ dBm})$	1 MHz
$5 \text{ MHz} \leq \Delta f \leq \min(\Delta f_{\text{max}}, 10 \text{ MHz})$	$5,5 \text{ MHz} \leq f_{\text{offset}} < \min(f_{\text{offset}_{\text{max}}}, 10,5 \text{ MHz})$	$P_{\text{Rated,c}} - 54,5 \text{ dB}$	1 MHz
$10 \text{ MHz} \leq \Delta f \leq \Delta f_{\text{max}}$	$10,5 \text{ MHz} \leq f_{\text{offset}} < f_{\text{offset}_{\text{max}}}$	$P_{\text{Rated,c}} - 56 \text{ dB}$ (note 3)	1 MHz
NOTE 1: For operation with a GSM/EDGE or standalone NB-IoT or an E-UTRA 1,4 or 3 MHz carrier adjacent to the Base Station RF bandwidth edge, the limits in table 4.2.2.2-5 shall apply for $0 \text{ MHz} \leq \Delta f < 0,15 \text{ MHz}$.			
NOTE 2: This frequency range ensures that the range of values of f_{offset} is continuous.			
NOTE 3: The requirement is not applicable when $\Delta f_{\text{max}} < \Delta f_{\text{OBUE}}$.			
NOTE 4: For MSR BS supporting non-contiguous spectrum operation within any operating band the test requirement within sub-block gaps is calculated as a cumulative sum of contributions from adjacent sub-blocks on each side of the sub-block gap, where the contribution from the far-end sub-block shall be scaled according to the measurement bandwidth of the near-end sub-block. Exception is $\Delta f \geq 10 \text{ MHz}$ from both adjacent sub-blocks on each side of the sub-block gap, where the requirement within sub-block gaps shall be $(P_{\text{Rated,c}} - 56 \text{ dB})/\text{MHz}$.			
NOTE 5: For MSR BS supporting multi-band operation with Inter RF bandwidth gap $< 2 \times \Delta f_{\text{OBUE}}$ operation the test requirement within the Inter RF bandwidth gaps is calculated as a cumulative sum of contributions from adjacent sub-blocks or Base Station RF Bandwidth on each side of the Inter RF bandwidth gap, where the contribution from the far-end sub-block or Base Station RF Bandwidth shall be scaled according to the measurement bandwidth of the near-end sub-block or Base Station RF Bandwidth.			

**Table 4.2.2.2-3A: Medium Range BS operating band Unwanted Emission Mask (UEM)
for BS supporting NR and not supporting UTRA nor GSM in BC2 bands,
BS maximum output power $31 < P_{\text{Rated,c}} \leq 38$ dBm**

Frequency offset of measurement filter -3 dB point, Δf	Frequency offset of measurement filter centre frequency, f_{offset}	Minimum requirement (see notes 1 and 2)	Measurement bandwidth
$0 \text{ MHz} \leq \Delta f < 5 \text{ MHz}$	$0,05 \text{ MHz} \leq f_{\text{offset}} < 5,05 \text{ MHz}$	$P_{\text{Rated,c}} - 51,5 \text{ dB} - 7/5(f_{\text{offset}}/\text{MHz} - 0,05)\text{dB}$	100 kHz
$5 \text{ MHz} \leq \Delta f < \min(10 \text{ MHz}, \Delta f_{\text{max}})$	$5,05 \text{ MHz} \leq f_{\text{offset}} < \min(10,05 \text{ MHz}, f_{\text{offset,max}})$	$P_{\text{Rated,c}} - 58,5 \text{ dB}$	100 kHz
$10 \text{ MHz} \leq \Delta f \leq \Delta f_{\text{max}}$	$10,05 \text{ MHz} \leq f_{\text{offset}} < f_{\text{offset,max}}$	$\text{Min}(P_{\text{Rated,c}} - 60 \text{ dB}, -25 \text{ dBm})$ (note 4)	100 kHz

NOTE 1: For MSR BS supporting non-contiguous spectrum operation within any operating band the minimum requirement within sub-block gaps is calculated as a cumulative sum of contributions from adjacent sub blocks on each side of the sub block gap, where the contribution from the far-end sub-block shall be scaled according to the measurement bandwidth of the near-end sub-block. Exception is $\Delta f \geq 10$ MHz from both adjacent sub blocks on each side of the sub-block gap, where the minimum requirement within sub-block gaps shall be $\text{Min}(P_{\text{Rated,c}} - 60 \text{ dB}, -25 \text{ dBm})/100 \text{ kHz}$.

NOTE 2: For MSR BS supporting multi-band operation with Inter RF Bandwidth gap $< 2 \times \Delta f_{\text{OBUE}}$ the minimum requirement within the Inter RF Bandwidth gaps is calculated as a cumulative sum of contributions from adjacent sub-blocks or RF Bandwidth on each side of the Inter RF Bandwidth gap, where the contribution from the far-end sub-block shall be scaled according to the measurement bandwidth of the near-end sub-block.

NOTE 3: For operation with a standalone NB-IoT or an E-UTRA 1,4 or 3 MHz carrier adjacent to the Base Station RF Bandwidth edge, the limits in table 4.2.2.2-5 apply for $0 \text{ MHz} \leq \Delta f < 0,15 \text{ MHz}$.

NOTE 4: The requirement is not applicable when $\Delta f_{\text{max}} < \Delta f_{\text{OBUE}}$.

**Table 4.2.2.2-4: Medium Range BS operating band Unwanted Emission Mask (UEM)
for BC2, BS maximum output power $P_{\text{Rated,c}} \leq 31$ dBm for BS not supporting NR**

Frequency offset of measurement filter -3 dB point, Δf	Frequency offset of measurement filter centre frequency, f_{offset}	Test requirement (see notes 4 and 5)	Measurement bandwidth
$0 \text{ MHz} \leq \Delta f < 0,6 \text{ MHz}$ (see note 1)	$0,015 \text{ MHz} \leq f_{\text{offset}} < 0,615 \text{ MHz}$	$-25,5 \text{ dBm} - \frac{7}{5} \left(\frac{f_{\text{offset}}}{\text{MHz}} - 0,015 \right) \text{ dB}$	30 kHz
$0,6 \text{ MHz} \leq \Delta f < 1 \text{ MHz}$ (see note 2)	$0,615 \text{ MHz} \leq f_{\text{offset}} < 1,015 \text{ MHz}$	$-20,5 \text{ dBm} - 15 \cdot \left(\frac{f_{\text{offset}}}{\text{MHz}} - 0,215 \right) \text{ dB}$	30 kHz
	$1,015 \text{ MHz} \leq f_{\text{offset}} < 1,5 \text{ MHz}$	-32,5 dBm	30 kHz
$1 \text{ MHz} \leq \Delta f \leq 5 \text{ MHz}$	$1,5 \text{ MHz} \leq f_{\text{offset}} < 5,5 \text{ MHz}$	-19,5 dBm	1 MHz
$5 \text{ MHz} \leq \Delta f \leq \min(\Delta f_{\text{max}}, 10 \text{ MHz})$	$5,5 \text{ MHz} \leq f_{\text{offset}} < \min(f_{\text{offset,max}}, 10,5 \text{ MHz})$	-23,5 dBm	1 MHz
$10 \text{ MHz} \leq \Delta f \leq \Delta f_{\text{max}}$	$10,5 \text{ MHz} \leq f_{\text{offset}} < f_{\text{offset,max}}$	-25 dBm (see note 3)	1 MHz

NOTE 1: For operation with a GSM/EDGE or standalone NB-IoT or an E-UTRA 1,4 or 3 MHz carrier adjacent to the Base Station RF bandwidth edge, the limits in table 4.2.2.2-6 shall apply for $0 \text{ MHz} \leq \Delta f < 0,15 \text{ MHz}$.

NOTE 2: This frequency range ensures that the range of values of f_{offset} is continuous.

NOTE 3: The requirement is not applicable when $\Delta f_{\text{max}} < \Delta f_{\text{OBUE}}$.

NOTE 4: For MSR BS supporting non-contiguous spectrum operation within any operating band the test requirement within sub-block gaps is calculated as a cumulative sum of contributions from adjacent sub-blocks on each side of the sub-block gap, where the contribution from the far-end sub-block shall be scaled according to the measurement bandwidth of the near-end sub-block. Exception is $\Delta f \geq 10$ MHz from both adjacent sub-blocks on each side of the sub-block gap, where the test requirement within sub-block gaps shall be -25 dBm/MHz.

NOTE 5: For MSR BS supporting multi-band operation with Inter RF bandwidth gap $< 2 \times \Delta f_{\text{OBUE}}$ operation the test requirement within the Inter RF bandwidth gaps is calculated as a cumulative sum of contributions from adjacent sub-blocks or Base Station RF Bandwidth on each side of the Inter RF bandwidth gap, where the contribution from the far-end sub-block or Base Station RF Bandwidth shall be scaled according to the measurement bandwidth of the near-end sub-block or Base Station RF Bandwidth.

**Table 4.2.2.2-4A: Medium Range BS operating band Unwanted Emission Mask (UEM)
for BS supporting NR and not supporting UTRA nor GSM in BC2 bands,
BS maximum output power $P_{Rated,c} \leq 31$ dBm**

Frequency offset of measurement filter -3 dB point, Δf	Frequency offset of measurement filter centre frequency, f_{offset}	Minimum requirement (see notes 1 and 2)	Measurement bandwidth
$0 \text{ MHz} \leq \Delta f < 5 \text{ MHz}$	$0,05 \text{ MHz} \leq f_{offset} < 5,05 \text{ MHz}$	- 20,5 dBm - $7/5(f_{offset}/\text{MHz} - 0,05)$ dB	100 kHz
$5 \text{ MHz} \leq \Delta f < \min(10 \text{ MHz}, \Delta f_{max})$	$5,05 \text{ MHz} \leq f_{offset} < \min(10,05 \text{ MHz}, f_{offset_{max}})$	-27,5 dBm	100 kHz
$10 \text{ MHz} \leq \Delta f \leq \Delta f_{max}$	$10,05 \text{ MHz} \leq f_{offset} < f_{offset_{max}}$	-29 dBm (note 4)	100 kHz
<p>NOTE 1: For MSR BS supporting non-contiguous spectrum operation within any operating band the minimum requirement within sub-block gaps is calculated as a cumulative sum of contributions from adjacent sub blocks on each side of the sub block gap, where the contribution from the far-end sub-block shall be scaled according to the measurement bandwidth of the near-end sub-block. Exception is $\Delta f \geq 10$ MHz from both adjacent sub blocks on each side of the sub-block gap, where the minimum requirement within sub-block gaps shall be -29 dBm/100 kHz.</p> <p>NOTE 2: For MSR BS supporting multi-band operation with Inter RF Bandwidth gap $< 2 \times \Delta f_{OBUE}$ the minimum requirement within the Inter RF Bandwidth gaps is calculated as a cumulative sum of contributions from adjacent sub-blocks or RF Bandwidth on each side of the Inter RF Bandwidth gap, where the contribution from the far-end sub-block shall be scaled according to the measurement bandwidth of the near-end sub-block.</p> <p>NOTE 3: For operation with a standalone NB-IoT or an E-UTRA 1,4 or 3 MHz carrier adjacent to the Base Station RF Bandwidth edge, the limits in table 4.2.2.2-6 apply for $0 \text{ MHz} \leq \Delta f < 0,15 \text{ MHz}$.</p> <p>NOTE 4: The requirement is not applicable when $\Delta f_{max} < \Delta f_{OBUE}$.</p>			

**Table 4.2.2.2-5: Medium Range operating band unwanted emission limits for operation in BC2
with GSM/EDGE or standalone NB-IoT or E-UTRA 1,4 or 3 MHz carriers adjacent to the Base Station
RF bandwidth edge, BS maximum output power $31 < P_{Rated,c} \leq 38$ dBm**

Frequency offset of measurement filter -3 dB point, Δf	Frequency offset of measurement filter centre frequency, f_{offset}	Test requirement (see notes 2 and 3)	Measurement bandwidth
$0 \text{ MHz} \leq \Delta f < 0,05 \text{ MHz}$	$0,015 \text{ MHz} \leq f_{offset} < 0,065 \text{ MHz}$	$P_{Rated,c} - 36,5 \text{ dB} - 60 \left(\frac{f_{offset}}{\text{MHz}} - 0,015 \right) \text{ dB}$	30 kHz
$0,05 \text{ MHz} \leq \Delta f < 0,15 \text{ MHz}$	$0,065 \text{ MHz} \leq f_{offset} < 0,165 \text{ MHz}$	$P_{Rated,c} - 39,5 \text{ dB} - 160 \left(\frac{f_{offset}}{\text{MHz}} - 0,065 \right) \text{ dB}$	30 kHz
<p>NOTE 1: The limits in this table only shall apply for operation with a GSM/EDGE or an E-UTRA 1,4 or 3 MHz carrier adjacent to the Base Station RF bandwidth edge.</p> <p>NOTE 2: For MSR BS supporting non-contiguous spectrum operation within any operating band the test requirement within sub-block gaps is calculated as a cumulative sum of contributions from adjacent sub-blocks on each side of the sub-block gap.</p> <p>NOTE 3: For MSR BS supporting multi-band operation with Inter RF bandwidth gap $< 2 \times \Delta f_{OBUE}$ operation the test requirement within the Inter RF bandwidth gaps is calculated as a cumulative sum of contributions from adjacent sub-blocks or Base Station RF Bandwidth on each side of the Inter RF bandwidth gap.</p>			

Table 4.2.2.2-6: Medium Range operating band unwanted emission limits for operation in BC2 with GSM/EDGE or standalone NB-IoT or E-UTRA 1,4 or 3 MHz carriers adjacent to the Base Station RF bandwidth edge, BS maximum output power $P_{\text{Rated,c}} \leq 31$ dBm

Frequency offset of measurement filter -3 dB point, Δf	Frequency offset of measurement filter centre frequency, f_{offset}	Test requirement (see notes 2, 3 and 4)	Measurement bandwidth
$0 \text{ MHz} \leq \Delta f < 0,05 \text{ MHz}$	$0,015 \text{ MHz} \leq f_{\text{offset}} < 0,065 \text{ MHz}$	$\text{Max}(-5,5 \text{ dBm} - 60 \cdot \left(\frac{f_{\text{offset}}}{\text{MHz}} - 0,015\right) \text{ dB} + X \text{ dB}, -25,5 \text{ dBm})$	30 kHz
$0,05 \text{ MHz} \leq \Delta f < 0,15 \text{ MHz}$	$0,065 \text{ MHz} \leq f_{\text{offset}} < 0,165 \text{ MHz}$	$\text{Max}(-8,5 \text{ dBm} - 160 \cdot \left(\frac{f_{\text{offset}}}{\text{MHz}} - 0,065\right) \text{ dB} + X \text{ dB}, -25,5 \text{ dBm})$	30 kHz

NOTE 1: The limits in this table only shall apply for operation with a GSM/EDGE or an E-UTRA 1,4 or 3 MHz carrier adjacent to the Base Station RF bandwidth edge.

NOTE 2: For MSR BS supporting non-contiguous spectrum operation within any operating band the test requirement within sub-block gaps is calculated as a cumulative sum of contributions from adjacent sub-blocks on each side of the sub-block gap.

NOTE 3: In case the carrier adjacent to the Base Station RF bandwidth edge is a GSM/EDGE carrier, the value of $X = P_{\text{GSMcarrier}} - 31$, where $P_{\text{GSMcarrier}}$ is the power level of the GSM/EDGE carrier adjacent to the Base Station RF bandwidth edge. In other cases, $X = 0$.

NOTE 4: For MSR BS supporting multi-band operation with Inter RF bandwidth gap $< 2 \times \Delta f_{\text{OBUE}}$ operation the test requirement within the Inter RF bandwidth gaps is calculated as a cumulative sum of contributions from adjacent sub-blocks or Base Station RF Bandwidth on each side of the Inter RF bandwidth gap.

NOTE 5: In case the carrier adjacent to the RF bandwidth edge is a NB-IoT carrier, the value of $X = P_{\text{NB-IoTcarrier}} - 31$, where $P_{\text{NB-IoTcarrier}}$ is the power level of the NB-IoT carrier adjacent to the RF bandwidth edge. In other cases, $X = 0$.

Table 4.2.2.2-7: Local Area operating band Unwanted Emission Mask (UEM) for BC2

Frequency offset of measurement filter -3 dB point, Δf	Frequency offset of measurement filter centre frequency, f_{offset}	Test requirement (see notes 3 and 4)	Measurement bandwidth
$0 \text{ MHz} \leq \Delta f < 5 \text{ MHz}$ (see note 1)	$0,05 \text{ MHz} \leq f_{\text{offset}} < 5,05 \text{ MHz}$	$-28,5 \text{ dBm} - \frac{7}{5} \left(\frac{f_{\text{offset}}}{\text{MHz}} - 0,05\right) \text{ dB}$	100 kHz
$5 \text{ MHz} \leq \Delta f < \min(10 \text{ MHz}, \Delta f_{\text{max}})$	$5,05 \text{ MHz} \leq f_{\text{offset}} < \min(10,05 \text{ MHz}, f_{\text{offset}_{\text{max}}})$	-35,5 dBm	100 kHz
$10 \text{ MHz} \leq \Delta f \leq \Delta f_{\text{max}}$	$10,05 \text{ MHz} \leq f_{\text{offset}} < f_{\text{offset}_{\text{max}}}$	-37 dBm (see note 2)	100 kHz

NOTE 1: For operation with a GSM/EDGE or standalone NB-IoT or an E-UTRA 1,4 or 3 MHz carrier adjacent to the Base Station RF bandwidth edge, the limits in table 4.2.2.2-8 shall apply for $0 \text{ MHz} \leq \Delta f < 0,16 \text{ MHz}$.

NOTE 2: The requirement is not applicable when $\Delta f_{\text{max}} < \Delta f_{\text{OBUE}}$.

NOTE 3: For MSR BS supporting non-contiguous spectrum operation within any operating band the test requirement within sub-block gaps is calculated as a cumulative sum of contributions from adjacent sub-blocks on each side of the sub-block gap. Exception is $\Delta f \geq 10 \text{ MHz}$ from both adjacent sub-blocks on each side of the sub-block gap, where the test requirement within sub-block gaps shall be -37 dBm/100 kHz.

NOTE 4: For MSR BS supporting multi-band operation with Inter RF bandwidth gap $< 2 \times \Delta f_{\text{OBUE}}$ operation the test requirement within the Inter RF bandwidth gaps is calculated as a cumulative sum of contributions from adjacent sub-blocks or Base Station RF Bandwidth on each side of the Inter RF bandwidth gap.

Table 4.2.2.2-8: Local Area operating band unwanted emission limits for operation in BC2 with GSM/EDGE or standalone NB-IoT or E-UTRA 1,4 or 3 MHz carriers adjacent to the Base Station RF bandwidth edge

Frequency offset of measurement filter -3 dB point, Δf	Frequency offset of measurement filter centre frequency, f_{offset}	Test requirement (see notes 2, 3 and 4)	Measurement bandwidth
$0 \text{ MHz} \leq \Delta f < 0,05 \text{ MHz}$	$0,015 \text{ MHz} \leq f_{\text{offset}} < 0,065 \text{ MHz}$	$\text{Max}(-12,5 \text{ dBm} - 60 \cdot \left(\frac{f_{\text{offset}}}{\text{MHz}} - 0,015\right) \text{ dB} + X \text{ dB}, -33,5 \text{ dBm})$	30 kHz
$0,05 \text{ MHz} \leq \Delta f < 0,16 \text{ MHz}$	$0,065 \text{ MHz} \leq f_{\text{offset}} < 0,175 \text{ MHz}$	$\text{Max}(-15,5 \text{ dBm} - 160 \cdot \left(\frac{f_{\text{offset}}}{\text{MHz}} - 0,065\right) \text{ dB} + X \text{ dB}, -33,5 \text{ dBm})$	30 kHz
<p>NOTE 1: The limits in this table only shall apply for operation with a GSM/EDGE or an E-UTRA 1,4 or 3 MHz carrier adjacent to the Base Station RF bandwidth edge.</p> <p>NOTE 2: For MSR BS supporting non-contiguous spectrum operation within any operating band the test requirement within sub-block gaps is calculated as a cumulative sum of contributions from adjacent sub-blocks on each side of the sub-block gap.</p> <p>NOTE 3: In case the carrier adjacent to the Base Station RF bandwidth edge is a GSM/EDGE carrier, the value of $X = P_{\text{GSMcarrier}} - 24$, where $P_{\text{GSMcarrier}}$ is the power level of the GSM/EDGE carrier adjacent to the Base Station RF bandwidth edge. In other cases, $X = 0$.</p> <p>NOTE 4: For MSR BS supporting multi-band operation with Inter RF bandwidth gap $< 2 \times \Delta f_{\text{OBUE}}$ operation the test requirement within the Inter RF bandwidth gaps is calculated as a cumulative sum of contributions from adjacent sub-blocks or Base Station RF Bandwidth on each side of the Inter RF bandwidth gap.</p> <p>NOTE 5: In case the carrier adjacent to the RF bandwidth edge is a NB-IoT carrier, the value of $X = P_{\text{NB-IoTcarrier}} - 24$, where $P_{\text{NB-IoTcarrier}}$ is the power level of the NB-IoT carrier adjacent to the RF bandwidth edge. In other cases, $X = 0$.</p>			

4.2.2.2.3 Limits for GSM/EDGE single-RAT operation

The following test requirements and the corresponding test method specified in ETSI EN 301 502 [9] shall apply to an MSR Base Station for any operating band with GSM/EDGE single RAT operation in Band Category 2:

- Spectrum due to the modulation and wide band noise, applicable parts of clause 4.2.4.1 of ETSI EN 301 502 [9].
- Spectrum due to switching transients, applicable parts of clause 4.2.4.2 of ETSI EN 301 502 [9].
- Emission requirement for frequency offsets of between 2 MHz and 10 MHz outside relevant transmit band, applicable parts of clause 4.2.5.2 of ETSI EN 301 502 [9].
- Intra BTS Intermodulation, applicable parts of clause 4.2.8 of ETSI EN 301 502 [9].

4.2.2.2.4 Void

4.2.2.2.5 Void

4.2.2.2.6 Void

4.2.2.2.7 Additional limits for operation in bands in 50 and 75 within 1 432 to 1 452 MHz, and in bands 51 and 76

The following requirement shall apply to E-UTRA or NR BS operating in Band 50 and Band 75 within 1 432 to 1 452 MHz, and in Band 51 and Band 76. Emissions shall not exceed the maximum levels specified in table 4.2.2.2.7-1.

Table 4.2.2.2.7-1: Additional operating band unwanted emission limits for BS operating in Band 50 and 75 within 1 432 MHz to 1 452 MHz, and in Band 51 and 76

Filter centre frequency, F_{filter}	Maximum Level [dBm]	Measurement Bandwidth
$F_{\text{filter}} = 1\,413,5$ MHz	-42	27 MHz

4.2.2.2.8 Additional limits for operation in band 43 for co-existence with FSS/FS

The following requirement shall apply to MSR BS operation in band 43 for co-existence with FSS/FS. Emissions shall not exceed the maximum levels specified in table 4.2.2.2.8-1.

Table 4.2.2.2.8-1: Additional operating band unwanted emission limits for band 43

Frequency range	Limit	Measurement bandwidth
3 800 MHz to 3 805 MHz	0 dBm	5 MHz
3 805 MHz to 3 810 MHz	-6 dBm	5 MHz
3 810 MHz to 3 840 MHz	-8 dBm	5 MHz
Above 3 840 MHz	-23 dBm	5 MHz

For a BS operating in band 43, additional parameters for protection of systems above 3,8 GHz are described in Decision (EU) 2019/235 [i.7]. Limits in table 4.2.2.2.8-1 are derived assuming a 21 dBi antenna gain.

4.2.2.3 Conformance

Conformance tests described in clause 5.3.1 shall be carried out.

4.2.3 Adjacent Channel Leakage power Ratio (ACLR)

4.2.3.1 Definition

Unwanted emissions consist of out-of-band emissions and spurious emissions (Recommendation ITU-R SM.329-12 [i.5]). Out of band emissions are emissions immediately outside the channel bandwidth resulting from the modulation process and non-linearity in the transmitter but excluding spurious emissions. The out-of-band emissions requirement for the BS transmitter is specified both in terms of Adjacent Channel Leakage power Ratio (ACLR) and Operating band unwanted emissions.

Adjacent Channel Leakage power Ratio (ACLR) is the ratio of the filtered mean power centred on the assigned channel frequency to the filtered mean power centred on an adjacent channel frequency.

4.2.3.2 Limits

4.2.3.2.1 E-UTRA limits

For E-UTRA, the limits are specified in tables 4.2.3.2.1-1 and 4.2.3.2.1-2, and shall apply outside the Base Station RF bandwidth or Maximum Radio Bandwidth.

In addition inside any frequency gap with a gap size $W_{\text{gap}} \geq 15$ MHz and $W_{\text{gap}} \geq 20$ MHz for a BS operating in non-contiguous spectrum, the ACLR test requirement for the first and second adjacent channels, respectively, in tables 4.2.3.2.1-3 and 4.2.3.2.1-4 applies.

For a BS operating in non-contiguous spectrum the CACLR test requirement in clause 4.2.3.2.4 applies in sub-block gaps for the frequency ranges defined in table 4.2.3.2.4-1.

For a BS operating in multiple bands, where multiple bands are mapped on the same antenna connector, the CACLR requirement in clause 4.2.3.2.4 applies in inter-RF bandwidth gaps for the frequency ranges defined in table 4.2.3.2.4-1.

The requirement applies during the transmitter on period.

The ACLR is defined with a square filter of bandwidth equal to the transmission bandwidth configuration of the transmitted signal (BW_{Config}) centered on the assigned channel frequency and a filter centered on the adjacent channel frequency according to tables 4.2.3.2.1-1 to 4.2.3.2.1-4.

For Wide Area BS, either the ACLR limits in the tables below or the absolute limit of -15 dBm/MHz apply, whichever is less stringent.

For Medium Range BS, either the ACLR limits in the tables below or the absolute limit of -25 dBm/MHz shall apply, whichever is less stringent.

For Local Area BS, either the ACLR limits in the tables below or the absolute limit of -32 dBm/MHz shall apply, whichever is less stringent.

For operation in paired spectrum, the ACLR shall be higher than the value specified in table 4.2.3.2.1-1.

Table 4.2.3.2.1-1: Base Station ACLR in paired spectrum

Channel bandwidth of E-UTRA lowest (highest) carrier transmitted BW_{Channel} [MHz]	BS adjacent channel centre frequency offset below the lowest or above the highest RF bandwidth edge frequency	Assumed adjacent channel carrier	Filter on the adjacent channel frequency and corresponding filter bandwidth	ACLR limit
1,4; 3; 5; 10; 15; 20	$0,5 \times BW_{\text{Channel}}$	E-UTRA of same BW	Square (BW_{Config})	44,2 dB
	$1,5 \times BW_{\text{Channel}}$	E-UTRA of same BW	Square (BW_{Config})	44,2 dB
	2,5 MHz	3,84 Mcps UTRA	RRC (3,84 Mcps)	44,2 dB
	7,5 MHz	3,84 Mcps UTRA	RRC (3,84 Mcps)	44,2 dB
NOTE 1: BW_{Channel} and BW_{Config} are the channel bandwidth and transmission bandwidth configuration of the E-UTRA lowest (highest) carrier transmitted on the assigned channel frequency.				
NOTE 2: The RRC filter shall be equivalent to the transmit pulse shape filter defined in ETSI TS 125 105 [3], with a chip rate as defined in this table.				

For operation in unpaired spectrum, the ACLR shall be higher than the value specified in table 4.2.3.2.1-2.

Table 4.2.3.2.1-2: Base Station ACLR in unpaired spectrum with synchronized operation

Channel bandwidth of E-UTRA lowest (highest) carrier transmitted BW_{Channel} [MHz]	BS adjacent channel centre frequency offset below the lowest or above the highest RF bandwidth edge frequency	Assumed adjacent channel carrier	Filter on the adjacent channel frequency and corresponding filter bandwidth	ACLR limit
1,4; 3	$0,5 \times BW_{\text{Channel}}$	E-UTRA of same BW	Square (BW_{Config})	44,2 dB
	$1,5 \times BW_{\text{Channel}}$	E-UTRA of same BW	Square (BW_{Config})	44,2 dB
	0,8 MHz	1,28 Mcps UTRA	RRC (1,28 Mcps)	44,2 dB
	2,4 MHz	1,28 Mcps UTRA	RRC (1,28 Mcps)	44,2 dB
5; 10; 15; 20	$0,5 \times BW_{\text{Channel}}$	E-UTRA of same BW	Square (BW_{Config})	44,2 dB
	$1,5 \times BW_{\text{Channel}}$	E-UTRA of same BW	Square (BW_{Config})	44,2 dB
	0,8 MHz	1,28 Mcps UTRA	RRC (1,28 Mcps)	44,2 dB
	2,4 MHz	1,28 Mcps UTRA	RRC (1,28 Mcps)	44,2 dB
	2,5 MHz	3,84 Mcps UTRA	RRC (3,84 Mcps)	44,2 dB
	7,5 MHz	3,84 Mcps UTRA	RRC (3,84 Mcps)	44,2 dB
	5 MHz	7,68 Mcps UTRA	RRC (7,68 Mcps)	44,2 dB
	15 MHz	7,68 Mcps UTRA	RRC (7,68 Mcps)	44,2 dB
NOTE 1: BW_{Channel} and BW_{Config} are the channel bandwidth and transmission bandwidth configuration of the E-UTRA lowest (highest) carrier transmitted on the assigned channel frequency.				
NOTE 2: The RRC filter shall be equivalent to the transmit pulse shape filter defined in ETSI TS 125 104 [2], with a chip rate as defined in this table.				

For operation in non-contiguous paired spectrum, the ACLR shall be higher than the value specified in table 4.2.3.2.1-3.

Table 4.2.3.2.1-3: Base Station ACLR in non-contiguous paired spectrum

Sub-block gap size (W_{gap}) where the limit applies	BS adjacent channel centre frequency offset below or above the sub-block edge (inside the gap)	Assumed adjacent channel carrier	Filter on the adjacent channel frequency and corresponding filter bandwidth	ACLR limit
$W_{\text{gap}} \geq 15$ MHz	2,5 MHz	3,84 Mcps UTRA	RRC (3,84 Mcps)	44,2 dB
$W_{\text{gap}} \geq 20$ MHz	7,5 MHz	3,84 Mcps UTRA	RRC (3,84 Mcps)	44,2 dB
NOTE: The RRC filter shall be equivalent to the transmit pulse shape filter defined in ETSI TS 125 104 [2], with a chip rate as defined in this table.				

For operation in non-contiguous unpaired spectrum, the ACLR shall be higher than the value specified in table 4.2.3.2.1-4.

Table 4.2.3.2.1-4: Base Station ACLR in non-contiguous unpaired spectrum

Sub-block gap size (W_{gap}) where the limit applies	BS adjacent channel centre frequency offset below or above the sub-block edge (inside the gap)	Assumed adjacent channel carrier	Filter on the adjacent channel frequency and corresponding filter bandwidth	ACLR limit
$W_{\text{gap}} \geq 15$ MHz	2,5 MHz	5 MHz E-UTRA	Square (BW_{Config})	44,2 dB
$W_{\text{gap}} \geq 20$ MHz	7,5 MHz	5 MHz E-UTRA	Square (BW_{Config})	44,2 dB

4.2.3.2.2 UTRA FDD limits

For UTRA FDD, the limits are specified in ETSI EN 301 908-3 [6], clause 4.2.3, and shall apply outside the Base Station RF bandwidth or Maximum Radio Bandwidth.

For a BS operating in non-contiguous spectrum, ACLR requirement shall also apply for the first adjacent channel, inside any sub-block gap with a gap size $W_{\text{gap}} \geq 15$ MHz. The ACLR requirement for the second adjacent channel shall apply inside any sub-block gap with a gap size $W_{\text{gap}} \geq 20$ MHz. The CAACLR test requirement in clause 4.2.3.2.4 shall apply in sub-block gaps for the frequency ranges defined in table 4.2.3.2.4-1.

For a BS operating in multiple bands, where multiple bands are mapped onto the same antenna connector, ACLR requirement shall also apply for the first adjacent channel, inside any Inter RF bandwidth gap with a gap size $W_{\text{gap}} \geq 15$ MHz. The ACLR requirement for the second adjacent channel shall apply inside any Inter RF bandwidth gap with a gap size $W_{\text{gap}} \geq 20$ MHz. The CAACLR requirement in clause 4.2.3.2.4 shall apply in Inter RF bandwidth gaps for the frequency ranges defined in table 4.2.3.2.4-1.

4.2.3.2.3 UTRA TDD limits

For UTRA TDD, the limits are specified in ETSI TS 125 142 [13], clause 6.6.2.2.5, and shall apply outside the Base Station RF bandwidth or Maximum Radio Bandwidth.

4.2.3.2.4 Cumulative ACLR requirement in non-contiguous spectrum

The following requirement shall apply for the sub-block or Inter RF bandwidth gap sizes listed in table 4.2.3.2.4-1:

- Inside a sub-block gap within an operating band for a BS operating in non-contiguous spectrum.
- Inside an Inter RF bandwidth gap for a BS operating in multiple bands, where multiple bands are mapped on the same antenna connector.

The Cumulative Adjacent Channel Leakage power Ratio (CACLR) in a sub-block gap or the Inter RF bandwidth gap is the ratio of:

- a) the sum of the filtered mean power centred on the assigned channel frequencies for the two carriers adjacent to each side of the sub-block gap or the Inter RF bandwidth gap; and
- b) the filtered mean power centred on a frequency channel adjacent to one of the respective sub-block edges or Base Station RF bandwidth edges.

The requirement shall apply to adjacent channels of NR, E-UTRA or UTRA carriers allocated adjacent to each side of the sub-block gap or the Inter RF bandwidth gap. The assumed filter for the adjacent channel frequency is defined in table 4.2.3.2.4-1 and the filters on the assigned channels are defined in table 4.2.3.2.4-2.

NOTE: If the RAT on the assigned channel frequencies are different, the filters used are also different.

For Wide Area BS, either the CACLR limits in table 4.2.3.2.4-1 or the absolute limit of -15 dBm/MHz shall apply, whichever is less stringent.

For Medium Range BS, either the CACLR limits in table 4.2.3.2.4-1 or the absolute limit of -25 dBm/MHz shall apply, whichever is less stringent.

For Local Area BS, either the CACLR limits in table 4.2.3.2.4-1 or the absolute limit of -32 dBm/MHz shall apply, whichever is less stringent.

The CACLR for E-UTRA and UTRA carriers located on either side of the sub-block gap or the Inter RF bandwidth gap shall be higher than the value specified in table 4.2.3.2.4-1.

Table 4.2.3.2.4-1: Base Station CACLR in non-contiguous spectrum or multiple bands

Band Category	Sub-block or Inter RF bandwidth gap size (W_{gap}) where the limit applies [MHz]	BS adjacent channel centre frequency offset below or above the sub-block edge or the Base Station RF bandwidth edge (inside the gap)	Assumed adjacent channel carrier (informative)	Filter on the adjacent channel frequency and corresponding filter bandwidth	CACLR limit
BC1, BC2	$5 \leq W_{\text{gap}} < 15$	2,5 MHz	3,84 Mcps UTRA	RRC (3,84 Mcps)	44,2 dB
BC1, BC2	$10 \leq W_{\text{gap}} < 20$	7,5 MHz	3,84 Mcps UTRA	RRC (3,84 Mcps)	44,2 dB
BC3	$5 \text{ MHz} \leq W_{\text{gap}} < 15$	2,5 MHz	5 MHz E-UTRA	Square (BW_{Config})	44,2 dB
BC3	$10 < W_{\text{gap}} < 20$	7,5 MHz	5 MHz E-UTRA	Square (BW_{Config})	44,2 dB
BC1, BC2, BC3	$5 \leq W_{\text{gap}} < 45$ (note 4)	2,5 MHz	5 MHz NR (note 2)	Square (BW_{Config})	44,2 dB
BC1, BC2, BC3	$10 \leq W_{\text{gap}} < 50$ (note 4)	7,5 MHz	5 MHz NR (note 2)	Square (BW_{Config})	44,2 dB
BC1, BC2, BC3	$20 \leq W_{\text{gap}} < 30$ (notes 3, 5)	10 MHz	20 MHz NR (note 2)	Square (BW_{Config})	44,2 dB
BC1, BC2, BC3	$20 \leq W_{\text{gap}} < 60$ (note 4)	10 MHz	20 MHz NR (note 2)	Square (BW_{Config})	44,2 dB
BC1, BC2, BC3	$40 \leq W_{\text{gap}} < 50$ (notes 3, 5)	30 MHz	20 MHz NR (note 2)	Square (BW_{Config})	44,2 dB
BC1, BC2, BC3	$40 \leq W_{\text{gap}} < 80$ (note 4)	30 MHz	20 MHz NR (note 2)	Square (BW_{Config})	44,2 dB

NOTE 1: For BC1 and BC2 the RRC filter shall be equivalent to the transmit pulse shape filter defined in ETSI TS 125 104 [2], with a chip rate as defined in this table.

NOTE 2: With SCS that provides largest transmission bandwidth configuration (BW_{Config}).

NOTE 3: Applicable in case the *channel bandwidth* of the carrier transmitted at the other edge of the gap is 5, 10, 15, 20 MHz.

NOTE 4: Applicable in case the *channel bandwidth* of the NR carrier transmitted at the other edge of the gap is 25, 30, 40, 50, 60, 70, 80, 90, 100 MHz.

NOTE 5: Applicable in case the *channel bandwidth* of the lowest/highest NR carrier transmitted is 25, 30, 40, 50, 60, 70, 80, 90, 100 MHz.

Table 4.2.3.2.4-2: Filter parameters for the assigned channel

RAT of the carrier adjacent to the sub-block or Inter RF bandwidth gap	Filter on the assigned channel frequency and corresponding filter bandwidth
E-UTRA	E-UTRA of same BW
UTRA FDD	RRC (3,84 Mcps)
NR	NR of same BW with SCS that provides largest transmission bandwidth configuration
NOTE: The RRC filter shall be equivalent to the transmit pulse shape filter defined in ETSI TS 125 104 [2], with a chip rate as defined in this table.	

4.2.3.2.5 NB-IoT test requirement

For NB-IoT in-band and guard band operation, the E-UTRA minimum requirement specified in clause 4.2.3.2.1 shall apply.

For NB-IoT standalone operation, the ACLR shall be higher than the value specified in table 4.2.3.2.5-1.

Table 4.2.3.2.5-1: Base Station ACLR for NB-IoT standalone operation

Channel bandwidth of standalone NB-IoT lowest/highest carrier transmitted BW_{Channel}	BS adjacent channel centre frequency offset below the lowest or above the highest carrier centre frequency transmitted	Assumed adjacent channel carrier (informative)	Filter on the adjacent channel frequency and corresponding filter bandwidth	ACLR limit
200 kHz	300 kHz	Standalone NB-IoT	Square (BW_{Config})	39,2 dB
	500 kHz	Standalone NB-IoT	Square (BW_{Config})	49,2 dB
NOTE: BW_{Config} is the transmission bandwidth configuration of the E-UTRA Lowest/Highest Carrier transmitted on the assigned channel frequency.				

4.2.3.2.6 NR test requirement

For NR, the requirements shall apply outside the Base Station RF Bandwidth or Radio Bandwidth whatever the type of transmitter considered (single carrier or multi-carrier) and for all transmission modes foreseen by the manufacturer's specification.

For a BS operating in non-contiguous spectrum, the ACLR requirement shall apply in *sub-block gaps* for the frequency ranges defined in table 4.2.3.2.6-3, while the CACLR requirement shall apply in *sub-block gaps* for the frequency ranges defined in table 4.2.3.2.4-1.

For BS operating in multiple bands, where multiple bands are mapped onto the same *antenna connector*, the ACLR requirement shall apply in *Inter RF Bandwidth gaps* for the frequency ranges defined in table 4.2.3.2.6-3, while the CACLR requirement in clause 4.2.3.2.4 shall apply in *Inter RF Bandwidth gaps* for the frequency ranges defined in table 4.2.3.2.4-1.

The requirement shall apply during the *transmitter ON period*. The ACLR is defined with a square filter of bandwidth equal to the transmission bandwidth configuration of the transmitted signal (BW_{Config}) centred on the assigned channel frequency and a filter centred on the adjacent channel frequency according to the tables below.

The ACLR absolute *limit* in table 4.2.3.2.6-2 or the ACLR (CACLR) *limit* in table 4.2.3.2.6-1, 4.2.3.2.6-3 or 4.2.3.2.4-1, whichever is less stringent, shall apply for each *antenna connector*.

For operation in paired and unpaired spectrum, the ACLR shall be higher than the value specified in table 4.2.3.2.6-1.

Table 4.2.3.2.6-1: Base station ACLR limit

Channel bandwidth of lowest/highest NR carrier transmitted BW_{Channel} [MHz]	BS adjacent channel centre frequency offset below the lowest or above the highest carrier centre frequency transmitted	Assumed adjacent channel carrier (informative)	Filter on the adjacent channel frequency and corresponding filter bandwidth	ACLR limit
5, 10, 15, 20, 25, 30, 40, 50, 60, 70, 80, 90, 100	BW_{Channel}	NR of same BW (note 2)	Square (BW_{Config})	44,2 dB
	$2 \times BW_{\text{Channel}}$	NR of same BW (note 2)	Square (BW_{Config})	44,2 dB
	$BW_{\text{Channel}}/2 + 2,5$ MHz	5 MHz E-UTRA	Square (4,5 MHz)	44,2 dB (note 3)
	$BW_{\text{Channel}}/2 + 7,5$ MHz	5 MHz E-UTRA	Square (4,5 MHz)	44,2 dB (note 3)
NOTE 1: BW_{Channel} and BW_{Config} are the <i>channel bandwidth</i> and transmission bandwidth configuration of the lowest/highest NR carrier transmitted on the assigned channel frequency. NOTE 2: With SCS that provides largest transmission bandwidth configuration (BW_{Config}). NOTE 3: The requirements are applicable when the band is also defined for E-UTRA or UTRA.				

The ACLR absolute limit is specified in table 4.2.3.2.6-2.

Table 4.2.3.2.6-2: Base station ACLR absolute limit

BS class	ACLR absolute limit
Wide Area BS	-15 dBm/MHz
Medium Range BS	-25 dBm/MHz
Local Area BS	-32 dBm/MHz

For operation in non-contiguous spectrum or multiple bands, the ACLR shall be higher than the value specified in table 4.2.3.2.6-3.

Table 4.2.3.2.6-3: Base Station ACLR limit in non-contiguous spectrum or multiple bands

Channel bandwidth of lowest/highest NR carrier transmitted BW_{Channel} [MHz]	Sub-block or Inter RF Bandwidth gap size (W_{gap}) where the limit applies [MHz]	BS adjacent channel centre frequency offset below or above the sub-block or Base Station RF Bandwidth edge (inside the gap)	Assumed adjacent channel carrier	Filter on the adjacent channel frequency and corresponding filter bandwidth	ACLR limit
5, 10, 15, 20	$W_{\text{gap}} \geq 15$ (note 3)	2,5 MHz	5 MHz NR (note 2)	Square (BW_{Config})	44,2 dB
	$W_{\text{gap}} \geq 45$ (note 4)				
	$W_{\text{gap}} \geq 20$ (note 3)	7,5 MHz	5 MHz NR (note 2)	Square (BW_{Config})	44,2 dB
	$W_{\text{gap}} \geq 50$ (note 4)				
25, 30, 40, 50, 60, 70, 80, 90, 100	$W_{\text{gap}} \geq 60$ (note 4)	10 MHz	20 MHz NR (note 2)	Square (BW_{Config})	44,2 dB
	$W_{\text{gap}} \geq 30$ (note 3)				
	$W_{\text{gap}} \geq 80$ (note 4)	30 MHz	20 MHz NR (note 2)	Square (BW_{Config})	44,2 dB
	$W_{\text{gap}} \geq 50$ (note 3)				
NOTE 1: BW_{Config} is the transmission bandwidth configuration of the assumed adjacent channel carrier. NOTE 2: With SCS that provides largest transmission bandwidth configuration (BW_{Config}). NOTE 3: Applicable in case the <i>channel bandwidth</i> of the NR carrier transmitted at the other edge of the gap is 5, 10, 15, 20 MHz. NOTE 4: Applicable in case the <i>channel bandwidth</i> of the NR carrier transmitted at the other edge of the gap is 25, 30, 40, 50, 60, 70, 80, 90, 100 MHz.					

4.2.3.3 Conformance

Conformance tests described in clause 5.3.2 shall be carried out.

4.2.4 Transmitter spurious emissions

4.2.4.1 Definition

Unwanted emissions consist of out-of-band emissions and spurious emissions (Recommendation ITU-R SM.329-12 [i.5]). Spurious emissions are emissions which are caused by unwanted transmitter effects such as harmonics emission, parasitic emission, intermodulation products and frequency conversion products, but exclude out-of-band emissions. This is measured at the Base Station antenna connector.

The transmitter spurious emission limits shall apply from 9 kHz to 12,75 GHz, excluding the frequency range from Δf_{OBUE} below the lowest frequency of the downlink operating band up to Δf_{OBUE} above the highest frequency of the downlink operating band. For BS capable of multi-band operation where multiple bands are mapped on the same antenna connector, this exclusion shall apply for each supported operating band. For BS capable of multi-band operation where multiple bands are mapped on separate antenna connectors, the single-band requirements shall apply and the multi-band exclusions and provisions are not applicable. For some operating bands the upper frequency limit is higher than 12,75 GHz. The values of Δf_{OBUE} are defined in table 4.2.2.1-1.

The requirements shall apply whatever the type of transmitter considered. It shall apply for all transmission modes foreseen by the manufacturer's specification. Unless otherwise stated, all requirements are measured as mean power (RMS).

4.2.4.2 Limits

4.2.4.2.1 Spurious emissions

The power of any spurious emission shall not exceed the limits in table 4.2.4.2.1-1.

Table 4.2.4.2.1-1: BS Spurious emissions limits

Frequency range	Maximum Level	Measurement Bandwidth	Note
9 kHz ↔ 150 kHz	-36 dBm	1 kHz	note 1
150 kHz ↔ 30 MHz	-36 dBm	10 kHz	note 1
30 MHz ↔ 1 GHz	-36 dBm	100 kHz	note 1
1 GHz ↔ 12,75 GHz	-30 dBm	1 MHz	note 2
12,75 GHz ↔ 5 th harmonic of the upper frequency edge of the downlink operating band	-30 dBm	1 MHz	notes 2 and 3
NOTE 1: Bandwidth aligns with the bandwidth in Recommendation ITU-R SM.329-12 [i.5], section 4.1.			
NOTE 2: Bandwidth aligns with the bandwidth in Recommendation ITU-R SM.329-12 [i.5], section 4.1. Upper frequency aligns with the upper frequency in Recommendation ITU-R SM.329-12 [i.5], section 2.5, table 1.			
NOTE 3: This spurious frequency range shall apply only for <i>operating bands</i> for which the 5 th harmonic of the upper frequency edge of the DL operating band is reaching beyond 12,75 GHz.			

4.2.4.2.2 Additional spurious emissions requirement for BC2

For a BS operating in Band Category 2 when GSM/EDGE is configured, the power of any spurious emission shall not exceed the limits in table 4.2.4.2.2-1.

For BS capable of multi-band operation, the limits in table 4.2.4.2.2-1 are only applicable when all supported operating bands belong to BC2 and GSM/EDGE is configured in all bands.

Table 4.2.4.2.2-1: Additional BS Spurious emissions limits for BC2

Frequency range	Frequency offset from transmitter operating band edge (see note)	Maximum Level	Measurement Bandwidth
500 MHz ↔ 1 GHz	10 MHz to 20 MHz	-36 dBm	300 kHz
	20 MHz to 30 MHz	-36 dBm	1 MHz
	≥ 30 MHz	-36 dBm	3 MHz
1 GHz ↔ 12,75 GHz	≥ 30 MHz	-30 dBm	3 MHz
NOTE: For BS capable of multi-band operation, the frequency offset is relative to the closest operating band.			

4.2.4.2.3 Co-existence with other systems

This requirement shall be applied for the protection of UE/MS and BS/BTS receivers of other systems.

The power of any spurious emission shall not exceed the limit specified in table 4.2.4.2.3-1. For BS capable of multi-band operation, the exclusions and conditions in the last column of table 4.2.4.2.3-1 shall apply for each supported operating band. For BS capable of multi-band operation where multiple bands are mapped on separate antenna connectors, the exclusions and conditions in the last column of table 4.2.4.2.3-1 shall apply for the operating band supported at that antenna connector.

Table 4.2.4.2.3-1: Spurious emissions limits for protection of other systems

Protected system	Frequency range for co-existence requirement	Maximum Level	Measurement Bandwidth	Exclusions and conditions
GSM900	921 MHz to 960 MHz	-57 dBm	100 kHz	This requirement shall not apply to BS operating in band 8.
	876 MHz to 915 MHz	-61 dBm	100 kHz	For the frequency range 880 MHz to 915 MHz, this requirement shall not apply to BS operating in band 8, since it is already covered by the requirement in clause 4.2.4.2.4.
DCS1800	1 805 MHz to 1 880 MHz	-47 dBm	100 kHz	This requirement shall not apply to BS operating in band 3.
	1 710 MHz to 1 785 MHz	-61 dBm	100 kHz	This requirement shall not apply to BS operating in band 3, since it is already covered by the requirement in clause 4.2.4.2.4.
UTRA FDD band I or E-UTRA band 1 or NR band n1	2 110 MHz to 2 170 MHz	-52 dBm	1 MHz	This requirement shall not apply to BS operating in band 1 or 65.
	1 920 MHz to 1 980 MHz	-49 dBm	1 MHz	This requirement shall not apply to BS operating in band 1 or 65, since it is already covered by the requirement in clause 4.2.4.2.4.
UTRA FDD band III or E-UTRA band 3 or NR band n3	1 805 MHz to 1 880 MHz	-52 dBm	1 MHz	This requirement shall not apply to BS operating in band 3.
	1 710 MHz to 1 785 MHz	-49 dBm	1 MHz	This requirement shall not apply to BS operating in band 3, since it is already covered by the requirement in clause 4.2.4.2.4.
UTRA FDD band VII or E-UTRA band 7 or NR band n7	2 620 MHz to 2 690 MHz	-52 dBm	1 MHz	This requirement shall not apply to BS operating in band 7.
	2 500 MHz to 2 570 MHz	-49 dBm	1 MHz	This requirement shall not apply to BS operating in band 7, since it is already covered by the requirement in clause 4.2.4.2.4.
UTRA FDD band VIII or E-UTRA band 8 or NR band n8	925 MHz to 960 MHz	-52 dBm	1 MHz	This requirement shall not apply to BS operating in band 8.
	880 MHz to 915 MHz	-49 dBm	1 MHz	This requirement shall not apply to BS operating in band 8, since it is already covered by the requirement in clause 4.2.4.2.4.
UTRA FDD band XX or E-UTRA band 20 or NR band n20	791 MHz to 821 MHz	-52 dBm	1 MHz	This requirement shall not apply to BS operating in band 20 or 28.
	832 MHz to 862 MHz	-49 dBm	1 MHz	This requirement shall not apply to BS operating in band 20, since it is already covered by the requirement in clause 4.2.4.2.4.

Protected system	Frequency range for co-existence requirement	Maximum Level	Measurement Bandwidth	Exclusions and conditions
UTRA FDD band XXII or E-UTRA band 22	3 510 MHz to 3 590 MHz	-52 dBm	1 MHz	This requirement shall not apply to BS operating in band 22, 42, 77 or 78.
	3 410 MHz to 3 490 MHz	-49 dBm	1 MHz	This requirement shall not apply to BS operating in band 22, since it is already covered by the requirement in clause 4.2.4.2.4. This requirement shall not apply to band 42.
E-UTRA band 28 or NR band n28	758 MHz to 803 MHz	-52 dBm	1 MHz	This requirement shall not apply to BS operating in band 20, 28 or 67.
	703 MHz to 748 MHz	-49 dBm	1 MHz	This requirement shall not apply to BS operating in band 28, since it is already covered by the requirement in clause 4.2.4.2.4. For BS operating in band 67, it applies for 703 MHz to 736 MHz. For E-UTRA BS operating in band 68, it applies for 728 MHz to 733 MHz.
E-UTRA band 31	462,5 MHz to 467,5 MHz	-52 dBm	1 MHz	This requirement shall not apply to BS operating in band 31 and 72.
	452,5 MHz to 457,5 MHz	-49 dBm	1 MHz	This requirement shall not apply to BS operating in band 31, since it is already covered by the requirement in clause 4.2.4.2.4. This requirement does not apply to BS operating in band 72.
UTRA FDD band XXXII or E-UTRA band 32	1 452 MHz to 1 496 MHz (note 3)	-52 dBm	1 MHz	This requirement shall not apply to BS operating in band 32, 50 or 75.
UTRA TDD band a) or E-UTRA band 33	1 900 MHz to 1 920 MHz	-52 dBm	1 MHz	This requirement shall not apply to BS operating in band 33.
UTRA TDD band d) or E-UTRA band 38 or NR band n38	2 570 MHz to 2 620 MHz	-52 dBm	1 MHz	This requirement shall not apply to BS operating in band 38 or 69. For operation in band 7, see note 2.
E-UTRA band 40 or NR band n40	2 300 MHz to 2 400 MHz	-52 dBm	1 MHz	This requirement shall not apply to BS operating in band 40.
E-UTRA band 41 or NR band n41	2 496 MHz to 2 690 MHz	-52 dBm	1 MHz	This requirement shall not apply to BS operating in band 41
E-UTRA band 42	3 400 MHz to 3 600 MHz	-52 dBm	1 MHz	This requirement shall not apply to BS operating in band 22, 42 43, 77 or 78.
E-UTRA band 43	3 600 MHz to 3 800 MHz	-52 dBm	1 MHz	This requirement shall not apply to BS operating in band 42, 43, 77 or 78.
E-UTRA band 46	5 150 MHz to 5 925 MHz	-52 dBm	1 MHz	This requirement shall not apply to BS operating in band 46.
E-UTRA band 50 or NR band n50	1 432 MHz to 1 517 MHz	-52 dBm	1 MHz	This requirement shall not apply to E-UTRA BS operating in band 32, 50, 51, 75 or 76.
E-UTRA band 51 or NR band n51	1 427 MHz to 1 432 MHz	-52 dBm	1 MHz	This requirement shall not apply to E-UTRA BS operating in band 50, 51, 75 or 76.
E-UTRA band 65 or NR band n65	2 110 MHz to 2 200 MHz	-52 dBm	1 MHz	This requirement shall not apply to BS operating in band 1 or 65.
	1 920 MHz to 2 010 MHz	-49 dBm	1 MHz	This requirement shall not apply to BS operating in band 65, since it is already covered by the requirement in clause 4.2.4.2.4. For BS operating in band 1, the requirement shall apply for 1 980 MHz to 2 010 MHz, while the rest is covered in clause 4.2.4.2.4.
E-UTRA band 67	738 MHz to 758 MHz	-52 dBm	1 MHz	This requirement shall not apply to BS operating in band 28 or 67.
E-UTRA band 68	753 MHz to 783 MHz	-52 dBm	1 MHz	This requirement shall not apply to BS operating in band 28 or 68.

Protected system	Frequency range for co-existence requirement	Maximum Level	Measurement Bandwidth	Exclusions and conditions
	698 MHz to 728 MHz	-49 dBm	1 MHz	This requirement shall not apply to BS operating in band 68, since it is already covered by the requirement in clause 4.2.4.2.4. For E-UTRA BS operating in band 28, the requirement shall apply between 698 MHz and 703 MHz, while the rest is covered in clause 4.2.4.2.4.
E-UTRA band 69	2 570 MHz to 2 620 MHz	-52 dBm	1 MHz	This requirement shall not apply to E-UTRA BS operating in band 38 or 69.
E-UTRA band 72	461 MHz to 466 MHz	-52 dBm	1 MHz	This requirement shall not apply to BS operating in band 31 and 72.
	451 MHz to 456 MHz	-49 dBm	1 MHz	This requirement shall not apply to BS operating in band 72, since it is already covered by the requirement in clause 4.2.4.2.4.
E-UTRA band 75 or NR band n75	1 432 MHz to 1 517 MHz	-52 dBm	1 MHz	This requirement does not apply to E-UTRA BS operating in band 32, 50, 51, 75 or 76.
E-UTRA band 76 or NR band n76	1 427 MHz to 1 432 MHz	-52 dBm	1 MHz	This requirement does not apply to E-UTRA BS operating in band 50, 51, 75 or 76.
NR band n77	3 300 MHz to 4 200 MHz	-52 dBm	1 MHz	This requirement shall not apply to BS operating in band 42, 43, 77 or 78.
NR band n78	3 300 MHz to 3 800 MHz	-52 dBm	1 MHz	This requirement shall not apply to BS operating in band 42, 43, 77 or 78.
E-UTRA Band 87	420 MHz to 425 MHz	-52 dBm	1 MHz	This requirement does not apply to E-UTRA BS operating in band 87 or 88.
	410 MHz to 415 MHz	-49 dBm	1 MHz	This requirement does not apply to E-UTRA BS operating in band 87, since it is already covered by the requirement in clause 4.2.4.2.4.
E-UTRA Band 88	422 MHz to 427 MHz	-52 dBm	1 MHz	This requirement does not apply to E-UTRA BS operating in band 87 or 88.
	412 MHz to 417 MHz	-49 dBm	1 MHz	This requirement does not apply to E-UTRA BS operating in band 88, since it is already covered by the requirement in clause 4.2.4.2.4. This requirement does not apply to E-UTRA BS operating in band 87.
NOTE 1: Where the table has two entries for the same or overlapping frequency ranges, both limits shall be applied.				
NOTE 2: As set out in the definition in clause 4.2.4.1, except for the cases where the noted requirements apply to a BS operating in band 28, the co-existence requirements in this table shall not apply for the 10 MHz frequency range immediately outside the downlink operating band (see table 1-1). This is also the case when the downlink operating band is adjacent to the band for the protected system in the table.				
NOTE 3: The co-existence requirement is specified for the full frequency range defined for band 32 in ETSI TS 137 141 [1].				

4.2.4.2.4 Protection of the BS receiver of own or different BS

This requirement shall be applied for FDD operation in order to prevent the receivers of the Base Stations being desensitized by emissions from the BS transmitter. It is measured at the transmit antenna port for any type of BS which has common or separate Tx/Rx antenna ports.

The power of any spurious emission shall not exceed the limits in table 4.2.4.2.4-1.

Table 4.2.4.2.4-1: BS Spurious emissions limits for protection of the BS receiver

BS Class	Band Category	Frequency range	Maximum Level	Measurement Bandwidth	Note
Wide Area BS	BC1	F_{UL_low} to F_{UL_high}	-96 dBm	100 kHz	
Wide Area BS	BC2	F_{UL_low} to F_{UL_high}	-98 dBm	100 kHz	
Medium Range BS	BC1, BC2	F_{UL_low} to F_{UL_high}	-91 dBm	100 kHz	
Local Area BS	BC1, BC2	F_{UL_low} to F_{UL_high}	-88 dBm	100 kHz	
NOTE 1: F_{UL_low} and F_{UL_high} are the lowest and highest frequency of the BS uplink operating band respectively.					
NOTE 2: For Band 28 BS, this requirement shall only apply in the uplink frequency range where the BS receiver is allowed to operate according to table 1-1.					

4.2.4.3 Conformance

Conformance tests described in clause 5.3.3 shall be carried out.

4.2.5 Base station maximum output power

4.2.5.1 Definition

Output power of the Base Station is the mean power delivered to a load with resistance equal to the nominal load impedance of the transmitter.

The configured carrier power is the target maximum power for a specific carrier for the operating mode set in the BS within the limits given by the manufacturer's declaration.

The maximum carrier output power, $P_{max,c}$ of the Base Station is the mean power level measured at the antenna connector during the transmitter ON period for a specific carrier in a specified reference condition.

4.2.5.2 Limits

In normal conditions, the maximum carrier output power shall for UTRA, E-UTRA and NR remain:

- within +2,7 dB and -2,7 dB of the manufacturer's rated carrier output power for carrier frequency $f \leq 3,0$ GHz;
- within +3,0 dB and -3,0 dB of the manufacturer's rated output power for carrier frequency $3,0$ GHz $< f \leq 4,2$ GHz;

and for GSM/EDGE and NB-IoT remain within +3,0 dB and -3,0 dB of the manufacturer's rated carrier output power.

In extreme conditions, maximum carrier output power shall for UTRA, E-UTRA and NR remain:

- within +3,2 dB and -3,2 dB of the manufacturer's rated carrier output power for carrier frequency $f \leq 3,0$ GHz;
- within +3,5 dB and -3,5 dB of the manufacturer's rated output power for carrier frequency $3,0$ GHz $< f \leq 4,2$ GHz;

and for GSM/EDGE and NB-IoT remain within +3,5 dB and -3,5 dB of the manufacturer's rated carrier output power.

4.2.5.3 Conformance

Conformance tests described in clause 5.3.4 shall be carried out.

4.2.6 Transmit intermodulation

4.2.6.1 Definition

The transmitter intermodulation requirement is a measure of the capability of the transmitter to inhibit the generation of signals in its nonlinear elements caused by presence of the wanted signal and an interfering signal reaching the transmitter via the antenna. The requirement shall apply during the transmitter ON period and the transmitter transient period.

The transmitter intermodulation level is the power of the intermodulation products when an interfering signal is injected into the antenna connector.

For BS capable of multi-band operation where multiple bands are mapped on separate antenna connectors, the single-band requirements shall apply regardless of the interfering signals position relative to the Inter RF bandwidth gap.

4.2.6.2 Limits

4.2.6.2.1 General limits

In the frequency range relevant for this test, the transmitter intermodulation level shall not exceed the unwanted emission limits in clauses 4.2.2.2, 4.2.3.2 and 4.2.4.2 in the presence of a wanted signal and an interfering signal according to table 4.2.6.2.1-1 for BS operation in BC1, BC2 and BC3. The measurement may be limited to frequencies on which third and fifth order intermodulation products appear, considering the width of these products and excluding the bandwidths of the wanted and interfering signals.

The requirement shall apply outside the Base Station RF bandwidth or Maximum Radio Bandwidth. The interfering signal offset is defined relative to the Base Station RF bandwidth edges or Maximum Radio Bandwidth edges.

For BS operating in non-contiguous spectrum, the requirement is also applicable inside a sub-block gap for interfering signal offsets where the interfering signal falls completely within the sub-block gap. The interfering signal offset is defined relative to the sub-block edges.

For BS capable of multi-band operation, the requirement shall apply relative to the Base Station RF bandwidth edges of each operating band. In case the Inter RF bandwidth gap is less than 15 MHz, the requirement in the gap shall apply only for interfering signal offsets where the interfering signal falls completely within the Inter RF bandwidth gap.

Table 4.2.6.2.1-1: Interfering signals for the Transmitter intermodulation requirement

Parameter	Value
Interfering signal type	E-UTRA signal of channel bandwidth 5 MHz
Interfering signal level	Mean power level 30 dB below the mean power of the wanted signal
Interfering signal centre frequency offset from edge of the Base Station RF bandwidth	2,5 MHz for modulated interferer 7,5 MHz for modulated interferer 12,5 MHz for modulated interferer
NOTE:	Interfering signal positions that are partially or completely outside of the downlink operating band of the Base Station are excluded from the requirement, unless the interfering signal positions fall within the frequency range of adjacent downlink operating bands listed in table 1-1. In case that none of the interfering signal positions fall completely within the frequency range of the downlink operating band, the test suite in clause 5.3.5 provides further guidance.

4.2.6.2.2 Additional limits (BC1 and BC2)

In the frequency range relevant for this test, the transmitter intermodulation level shall not exceed the unwanted emission limits in clauses 4.2.2.2, 4.2.3.2 and 4.2.4.2 in the presence of a wanted signal and an interfering signal according to table 4.2.6.2.2-1 for BS operation in BC2. The measurement may be limited to frequencies on which third and fifth order intermodulation products appear, considering the width of these products and excluding the bandwidths of the wanted and interfering signals.

The requirement shall apply outside of the Base Station RF bandwidth or Maximum Radio Bandwidth for BC2. The interfering signal offset is defined relative to the Base Station RF bandwidth edges or Maximum Radio Bandwidth edges.

For BS operating in non-contiguous spectrum in BC1 or BC2, the requirement is also applicable inside a sub-block gap larger than or equal to two times the interfering signal centre frequency offset. For BS operating in non-contiguous spectrum in BC1, the requirement is not applicable inside a sub-block gap with a gap size equal or larger than 5 MHz. The interfering signal offset is defined relative to the sub-block edges.

For BS capable of multi-band operation, the requirement shall apply relative to the Base Station RF bandwidth edges of a BC2 operating band. The requirement is also applicable for BC1 and BC2 inside an Inter RF bandwidth gap equal to or larger than two times the interfering signal centre frequency offset. For BS capable of multi-band operation, the requirement is not applicable for BC1 band inside an Inter RF bandwidth gap with a gap size equal to or larger than 5 MHz.

Table 4.2.6.2.2-1: Interfering signal for the Transmitter intermodulation requirement (BC2)

Parameter	Value
Interfering signal type	CW
Interfering signal level	Mean power level 30 dB below the mean power of the wanted signal
Interfering signal centre frequency offset from edge of the Base Station RF bandwidth	> 800 kHz for CW interferer
NOTE: Interfering signal positions that are partially or completely outside of the downlink operating band of the Base Station are excluded from the requirement.	

4.2.6.2.3 Additional limits (BC3)

In the frequency range relevant for this test, the transmitter intermodulation level shall not exceed the unwanted emission limits in clauses 4.2.2.2, 4.2.3.2 and 4.2.4.2 in the presence of a wanted signal and an interfering signal according to table 4.2.6.2.3-1 for BS operation in BC3. The measurement may be limited to frequencies on which third and fifth order intermodulation products appear, considering the width of these products and excluding the bandwidths of the wanted and interfering signals.

For BS capable of multi-band operation, the requirement shall apply relative to the Base Station RF bandwidth edges of each operating band. In case the Inter RF bandwidth gap is less than 3,2 MHz, the requirement in the gap shall apply only for interfering signal offsets where the interfering signal falls completely within the Inter RF bandwidth gap.

Table 4.2.6.2.3-1: Interfering signals for the Transmitter intermodulation requirement (BC3)

Parameter	Value
Interfering signal type	1,28 Mcps UTRA TDD signal of channel bandwidth 1,6 MHz
Interfering signal level	Mean power level 30 dB below the mean power of the wanted signal
Interfering signal centre frequency offset from edge of the Base Station RF bandwidth	0,8 MHz for modulated 1,28 Mcps TDD interferer 1,6 MHz for modulated 1,28 Mcps TDD interferer 2,4 MHz for modulated 1,28 Mcps TDD interferer
NOTE: Interfering signal positions that are partially or completely outside of the downlink operating band of the Base Station are excluded from the requirement.	

4.2.6.3 Conformance

Conformance tests described in clause 5.3.5 shall be carried out.

4.2.7 Receiver spurious emissions

4.2.7.1 Definition

The receiver spurious emissions power is the power of emissions generated or amplified in a receiver that appear at the BS receiver antenna connector. The requirements shall apply to all BS with separate RX and TX antenna ports. In this case for FDD BS the test shall be performed when both TX and RX are on, with the TX port terminated.

For TDD BS with common RX and TX antenna port the requirement shall apply during the Transmitter OFF period. For FDD BS with common RX and TX antenna port the transmitter spurious emission limits as specified in clause 4.2.4 are valid.

For BS capable of multi-band operation where multiple bands are mapped on separate antenna connectors, the single-band requirements shall apply and the excluded frequency range is only applicable for the operating band supported on each antenna connector.

Unless otherwise stated, a BS declared to be capable of E-UTRA with NB-IoT in-band and guard band operations (or any combination with GSM and/or UTRA and/or NR) is only required to pass the receiver spurious emissions tests for E-UTRA with guard band operation (or any combination with GSM and/or UTRA and/or NR). It is not required to perform the receiver spurious emissions tests again for E-UTRA with in-band operation (or any combination with GSM and/or UTRA and/or NR).

4.2.7.2 Limits

4.2.7.2.1 General limits

The power of any spurious emission shall not exceed the levels in table 4.2.7.2.1-1.

In addition to the requirements in table 4.2.7.2.1-1, the power of any spurious emission shall not exceed the limits specified in clauses 4.2.4.2.3 and 4.2.4.2.4.

Table 4.2.7.2.1-1: General spurious emission test requirement

Frequency range	Maximum level	Measurement Bandwidth	Note
30 MHz to 1 GHz	-57 dBm	100 kHz	
1 GHz to 12,75 GHz	-47 dBm	1 MHz	
12,75 GHz to 5 th harmonic of the upper frequency edge of the downlink operating band	-47 dBm	1 MHz	This spurious frequency range shall apply only for <i>operating bands</i> for which the 5 th harmonic of the upper frequency edge of the UL <i>operating band</i> is reaching beyond 12,75 GHz.
NOTE: The frequency range from $F_{\text{BW RF, DL, low}} - \Delta f_{\text{OBUE}}$ to $F_{\text{BW RF, DL, high}} + \Delta f_{\text{OBUE}}$ may be excluded from the requirement. For BS capable of multi-band operation, the exclusion shall apply for all supported operating bands. For BS capable of multi-band operation where multiple bands are mapped on separate antenna connectors, the single-band requirements shall apply and the excluded frequency range is only applicable for the operating band supported on each antenna connector.			

4.2.7.2.2 Additional limits for BC2

For a BS operating in Band Category 2 when GSM/EDGE is configured, the power of any spurious emissions shall not exceed the limits in table 4.2.7.2.2-1.

For BS capable of multi-band operation, the limits in table 4.2.7.2.2-1 are only applicable when all supported operating bands belong to BC2 and GSM/EDGE is configured in all bands.

Table 4.2.7.2.2-1: Additional BS spurious emissions limits for BC2

Frequency range	Frequency offset from transmitter operating band edge (see note)	Maximum level	Measurement Bandwidth
500 MHz to 1 GHz	10 MHz to 20 MHz	-57 dBm	300 kHz
	20 MHz to 30 MHz	-57 dBm	1 MHz
	≥ 30 MHz	-57 dBm	3 MHz
1 GHz to 12,75 GHz	≥ 30 MHz	-47 dBm	3 MHz
NOTE: For BS capable of multi-band operation, the frequency offset is relative to the closest supported operating band.			

4.2.7.3 Conformance

Conformance tests described in clause 5.3.6 shall be carried out.

4.2.8 In-band blocking

4.2.8.1 Definition

The in-band blocking characteristics is a measure of the receiver ability to receive a wanted signal at its assigned channel in the presence of an unwanted interferer inside the operating band.

The in-band blocking requirement applies from $F_{UL_low} - \Delta f_{OOB}$ to $F_{UL_high} + \Delta f_{OOB}$, excluding the downlink frequency range of the FDD *operating band*. The values of Δf_{OOB} are defined in table 4.2.8.1-1. For a BS with multi-RAT operation where the individual RATs are in different RAT specific bands that partially or fully overlap; Δf_{OOB} is according to the combined frequency range occupied by the overlapping bands.

Table 4.2.8.1-1: Maximum Δf_{OOB} offset outside the uplink operating band

Operating band characteristics	Δf_{OOB} [MHz]
$200 \text{ MHz} \geq F_{UL_high} - F_{UL_low}$	20
$200 \text{ MHz} < F_{UL_high} - F_{UL_low} \leq 900 \text{ MHz}$	60

Unless otherwise stated, a BS declared to be capable of E-UTRA with NB-IoT in-band and guard band operations (or any combination with GSM and/or UTRA and/or NR) is only required to pass the in-band blocking tests for E-UTRA with guard band operation (or any combination with GSM and/or UTRA and/or NR). It is not required to perform the in-band selectivity and blocking receiver tests again for E-UTRA with in-band operation (or any combination with GSM and/or UTRA and/or NR).

4.2.8.2 Limits

4.2.8.2.1 General limits

For the general blocking requirement, the interfering signal shall be a UTRA FDD signal as specified in clause A.1 of ETSI TS 137 141 [1] for a UTRA, E-UTRA, NB-IOT, GSM/EDGE or NR (≤ 20 MHz) wanted signal. The interfering signal shall be a 20 MHz E-UTRA signal for NR wanted signal channel bandwidth greater than 20 MHz.

The requirement shall apply outside of the Base Station RF bandwidth or Maximum Radio Bandwidth. The interfering signal offset is defined relative to the Base Station RF bandwidth edges or Maximum Radio Bandwidth edges.

For BS operating in non-contiguous spectrum, the requirement shall apply in addition inside any sub-block gap, in case the sub-block gap size is at least 15 MHz. The interfering signal offset is defined relative to the sub-block edges inside the sub-block gap.

For BS capable of multi-band operation, the requirement shall apply in addition inside any Inter RF bandwidth gap, in case the gap size is at least 15 MHz. The interfering signal offset is defined relative to the Base Station RF bandwidth edges inside the Inter RF bandwidth gap.

For the wanted and interfering signal coupled to the Base Station antenna input, using the parameters in table 4.2.8.2.1-1, the following requirements shall be met:

- For any measured E-UTRA carrier, the throughput shall be ≥ 95 % of the maximum throughput of the reference measurement channel defined in ETSI TS 136 104 [4], clause 7.2.
- For any measured UTRA FDD carrier, the BER shall not exceed 0,001 for the reference measurement channel defined in ETSI TS 125 104 [2], clause 7.2.
- For any measured UTRA TDD carrier, the BER shall not exceed 0,001 for the reference measurement channel defined in ETSI TS 125 105 [3], clause 7.2.
- For any measured GSM/EDGE carrier, the conditions in ETSI TS 145 005 [5], clause P.2.1 shall apply.
- For any measured NB-IoT carrier, the throughput shall be ≥ 95 % of the maximum throughput of the reference measurement channel defined in ETSI TS 136 104 [4], clause 7.2.
- For any measured NR carrier, the throughput shall be ≥ 95 % of the maximum throughput of the reference measurement channel defined in ETSI TS 138 104 [16], clause 7.2.

For BS capable of multi-band operation, the requirement shall apply according to table 4.2.8.2.1-1 for the in-band blocking frequency ranges of each supported operating band.

Table 4.2.8.2.1-1: General blocking requirement

Base Station Type	Mean power of interfering signal [dBm]	Wanted Signal mean power [dBm] (see note 1)	Centre Frequency of Interfering Signal	Interfering signal centre frequency minimum frequency offset from the Base Station RF bandwidth edge or edge of sub-block inside a gap [MHz]
Wide Area BS	-40+y (note 7)	$P_{\text{REFSENS}} + x$ dB (see notes 2 and 5)	$F_{\text{UL_low}} - \Delta f_{\text{OOB}}$ to $F_{\text{UL_high}} + \Delta f_{\text{OOB}}$ (note 8)	$\pm(7,5 + z)$ (note 9)
Medium Range BS	-35+y (note 7)	$P_{\text{REFSENS}} + x$ dB (see notes 3 and 5)		
Local Area BS	-30+y (note 7)	$P_{\text{REFSENS}} + x$ dB (see notes 4 and 5)		
NOTE 1: P_{REFSENS} depends on the RAT, the BS class and on the channel bandwidth, see clause 7.2 in ETSI TS 137 141 [1].				
NOTE 2: For WA BS not supporting NR, "x" is equal to 6 in case of E-UTRA, UTRA or NB-IoT wanted signals and equal to 3 in case of GSM/EDGE wanted signal.				
NOTE 3: For MR BS not supporting NR, "x" is equal to 6 in case of UTRA wanted signals, 9 in case of E-UTRA or NB-IoT wanted signal and 3 in case of GSM/EDGE wanted signal.				
NOTE 4: For LA BS not supporting NR, "x" is equal to 11 in case of E-UTRA or NB-IoT wanted signal, 6 in case of UTRA wanted signal and equal to 3 in case of GSM/EDGE wanted signal.				
NOTE 5: For a BS supporting NR and not supporting UTRA nor GSM, x is equal to 6.				
NOTE 6: For a BS capable of multi-band operation, "x" in notes 2, 3, 4, 5 shall apply in case of interfering signals that are in the in-band blocking frequency range of the operating band where the wanted signal is present or in an adjacent or overlapping band. For other in-band blocking frequency ranges of the interfering signal for the supported operating bands, "x" is equal to 1,4 dB.				
NOTE 7: For a BS not supporting NR, "y" is equal to zero for all BS classes. For a BS supporting NR and not supporting UTRA nor GSM, "y" is equal to -3 for the WA and MR BS class and -5 for the LA BS class.				
NOTE 8: The downlink frequency range of an FDD operating band is excluded from the general blocking requirement.				
NOTE 9: For NR wanted signal channel bandwidth greater than 20 MHz, $z = 22,5$. For all other cases, $z = 0$.				

Table 4.2.8.2.1-2: Void**4.2.8.2.2 Additional BC3 blocking limits**

The interfering signal is a 1,28 Mcps UTRA TDD modulated signal as specified in clause A.2 of ETSI TS 137 141 [1].

The requirement shall apply outside the Base Station RF bandwidth or Maximum Radio Bandwidth. The interfering signal offset is defined relative to the Base Station RF bandwidth edges or Maximum Radio Bandwidth edges.

For BS capable of multi-band operation, the requirement shall apply in addition inside any Inter RF bandwidth gap, in case the gap size is at least 4,8 MHz. The interfering signal offset is defined relative to the Base Station RF bandwidth edges inside the Inter RF bandwidth gap.

For the wanted and interfering signal coupled to the Base Station antenna input, using the parameters in table 4.2.8.2.2-1, the following requirements shall be met:

- For any measured E-UTRA TDD carrier, the throughput shall be ≥ 95 % of the maximum throughput of the reference measurement channel defined in ETSI TS 136 104 [4], clause 7.2.
- For any measured UTRA TDD carrier, the BER shall not exceed 0,001 for the reference measurement channel defined in ETSI TS 125 105 [3], clause 7.2.

Table 4.2.8.2.2-1: Additional blocking requirement for Band Category 3

Operating Band	Centre Frequency of Interfering Signal [MHz]	Interfering Signal mean power [dBm]	Wanted Signal mean power [dBm]	Interfering signal centre frequency minimum offset from the Base Station RF bandwidth edge or edge of sub-block inside a gap [MHz]
33, 38, 40, 41	$(F_{UL_low} - 20)$ to $(F_{UL_high} + 20)$	-40	$P_{REFSENS} + 6$ dB (see note)	$\pm 2,4$
NOTE: $P_{REFSENS}$ depends on the RAT and on the channel bandwidth, see clause 7.2 of ETSI TS 137 141 [1].				

4.2.8.3 Conformance

Conformance tests described in clause 5.3.7 shall be carried out.

4.2.9 Out-of-band blocking**4.2.9.1 Definition**

The Out-of-band blocking characteristic is a measure of the receiver ability to receive a wanted signal at its assigned channel in the presence of an unwanted interferer outside the uplink operating band.

Unless otherwise stated, a BS declared to be capable of E-UTRA with NB-IoT in-band and guard band operations (or any combination with GSM and/or UTRA and/or NR) is only required to pass the out-of-band blocking tests for E-UTRA with guard band operation (or any combination with GSM and/or UTRA and/or NR). It is not required to perform the out-of-band blocking receiver tests again for E-UTRA with in-band operation (or any combination with GSM and/or UTRA and/or NR).

4.2.9.2 Limits

The interfering signal shall be a CW carrier.

For a wanted and an interfering signal coupled to BS antenna input using the parameters in table 4.2.9.2-1, the following requirements shall be met:

- For any measured E-UTRA carrier, the throughput shall be ≥ 95 % of the maximum throughput of the reference measurement channel defined in ETSI TS 136 104 [4], clause 7.2.

- For any measured UTRA FDD carrier, the BER shall not exceed 0,001 for the reference measurement channel defined in ETSI TS 125 104 [2], clause 7.2.
- For any measured UTRA TDD carrier, the BER shall not exceed 0,001 for the reference measurement channel defined in ETSI TS 125 105 [3], clause 7.2.
- For any measured GSM/EDGE carrier, the conditions in ETSI TS 145 005 [5], clause P.2.1 shall apply.
- For any measured NB-IoT carrier, the throughput shall be ≥ 95 % of the maximum throughput of the reference measurement channel defined in ETSI TS 136 104 [4], clause 7.2.
- For any measured NR carrier, the throughput shall be ≥ 95 % of the maximum throughput of the reference measurement channel defined in ETSI TS 138 104 [16], clause 7.2.

For BS capable of multi-band operation, the requirements above shall apply for each supported operating band. The in-band blocking frequency ranges of all supported operating bands according to table 4.2.8.2.1-1 shall be excluded from the requirements.

The out-of-band blocking requirement applies from 1 MHz to $F_{UL_low} - \Delta f_{OOB}$ and from $F_{UL_high} + \Delta f_{OOB}$ up to 12 750 MHz, including the downlink frequency range of the FDD *operating band* for BS supporting FDD. Δf_{OOB} is defined in table 4.2.8.1-1.

Table 4.2.9.2-1: Out-of-band blocking performance requirement

Interfering Signal mean power [dBm]	Wanted Signal mean power [dBm]	Type of Interfering Signal
-15 (note 2)	$P_{REFSENS} + x$ dB (note 1)	CW carrier
NOTE 1: $P_{REFSENS}$ depends on the RAT, the BS class and the channel bandwidth, see clause 4.2.12. "x" is equal to 6 in case of NR, E-UTRA, UTRA or NB-IoT wanted signals and equal to 3 in case of GSM/EDGE wanted signal. NOTE 2: For NB-IoT, up to 24 exceptions are allowed for spurious response frequencies in each wanted signal frequency when measured using a 1 MHz step size. For these exceptions the above throughput requirement shall be met when the blocking signal is set to a level of -40 dBm for 15 kHz subcarrier spacing and -46 dBm for 3,75 kHz subcarrier spacing. In addition, each group of exceptions shall not exceed three contiguous measurements using a 1 MHz step size.		

4.2.9.3 Conformance

Conformance tests described in clause 5.3.8 shall be carried out.

4.2.10 Receiver intermodulation characteristics

4.2.10.1 Definition

Third and higher order mixing of the two interfering RF signals can produce an interfering signal in the band of the desired channel. Intermodulation response rejection is a measure of the capability of the receiver to receive a wanted signal on its assigned channel frequency in the presence of two interfering signals which have a specific frequency relationship to the wanted signal.

Unless otherwise stated, a BS declared to be capable of E-UTRA with NB-IoT in-band and guard band operations (or any combination with GSM and/or UTRA and/or NR) is only required to pass the receiver intermodulation tests for E-UTRA with guard band operation (or any combination with GSM and/or UTRA and/or NR). It is not required to perform the receiver intermodulation tests again for E-UTRA with in-band operation (or any combination with GSM and/or UTRA and/or NR).

4.2.10.2 Limits

4.2.10.2.1 General intermodulation limits

Interfering signals shall be a CW signal and an E-UTRA or UTRA signal, as specified in annex A of ETSI TS 137 141 [1].

The requirement shall apply outside the Base Station RF bandwidth or Maximum Radio Bandwidth. The interfering signal offset is defined relative to the Base Station RF bandwidth edges or Maximum Radio Bandwidth edges.

For BS capable of multi-band operation, the requirement shall apply in addition inside any Inter RF bandwidth gap, in case the gap size is at least twice as wide as the UTRA/E-UTRA interfering signal centre frequency offset from the Base Station RF bandwidth edge. The interfering signal offset is defined relative to the Base Station RF bandwidth edges inside the Inter RF bandwidth gap.

For the wanted signal at the assigned channel frequency and two interfering signals coupled to the Base Station antenna input, using the parameters in tables 4.2.10.2.1-1 and 4.2.10.2.1-2, the following requirements shall be met:

- For any measured E-UTRA carrier, the throughput shall be ≥ 95 % of the maximum throughput of the reference measurement channel defined in ETSI TS 136 104 [4], clause 7.2.
- For any measured UTRA FDD carrier, the BER shall not exceed 0,001 for the reference measurement channel defined in ETSI TS 125 104 [2], clause 7.2.
- For any measured UTRA TDD carrier, the BER shall not exceed 0,001 for the reference measurement channel defined in ETSI TS 125 105 [3], clause 7.2.
- For any measured GSM/EDGE carrier, the conditions in ETSI TS 145 005 [5], clause P.2.2 shall apply.
- For any measured NB-IoT carrier, the throughput shall be ≥ 95 % of the maximum throughput of the reference measurement channel defined in ETSI TS 136 104 [4], clause 7.2.
- For any measured NR carrier, the throughput shall be ≥ 95 % of the maximum throughput of the reference measurement channel defined in ETSI TS 138 104 [16], clause 7.2.

Table 4.2.10.2.1-1: General intermodulation requirement

Base Station Type	Mean power of interfering signals [dBm]	Wanted Signal mean power [dBm] (see notes)	Type of interfering signal
Wide Area BS	-48+y (note 6)	$P_{\text{REFSENS}} + x$ dB	See table 4.2.10.2.1-2
Medium Range BS	-44+y (note 6)	$P_{\text{REFSENS}} + x$ dB	
Local Area BS	-38+y (note 6)	$P_{\text{REFSENS}} + x$ dB	
NOTE 1: P_{REFSENS} depends on the RAT, the BS class and on the channel bandwidth, see clause 7.2 in ETSI TS 137 141 [1]. For E-UTRA channel bandwidths 10, 15 and 20 MHz this requirement shall apply only for a FRC A1-3 mapped to the frequency range at the channel edge adjacent to the interfering signals.			
NOTE 2: For WA BS not supporting NR, "x" is equal to 6 in case of E-UTRA, UTRA or NB-IoT wanted signals and equal to 3 in case of GSM/EDGE wanted signal.			
NOTE 3: For MR BS not supporting NR, "x" is equal to 6 in case of UTRA wanted signals, 9 in case of E-UTRA or NB-IoT wanted signal and equal to 3 in case of GSM/EDGE wanted signal.			
NOTE 4: For LA BS not supporting NR, "x" is equal to 12 in case of E-UTRA or NB-IoT wanted signals, 6 in case of UTRA wanted signal and equal to 3 in case of GSM/EDGE wanted signal.			
NOTE 5: For a BS that transmits NR in some configurations and does not transmit UTRA or GSM in any configuration, x is equal to 6.			
NOTE 6: For a BS not supporting NR, "y" is equal to zero for all BS classes. For a BS supporting NR and not supporting UTRA nor GSM; "y" is equal to -4 for the WA BS class, -3 for the MR BS class and -6 for the LA BS class.			

Table 4.2.10.2.1-2: Interfering signals for intermodulation requirement

RAT of the carrier adjacent to the high/low edge of the Base Station RF bandwidth	Interfering signal centre frequency offset from the Base Station RF bandwidth edge [MHz]	Type of interfering signal
E-UTRA 1,4 MHz	$\pm 2,0$ (BC1 and BC3) / $\pm 2,1$ (BC2)	CW
	$\pm 4,9$	1,4 MHz E-UTRA signal
E-UTRA or E-UTRA with NB-IoT in-band 3 MHz	$\pm 4,4$ (BC1 and BC3) / $\pm 4,5$ (BC2)	CW
	$\pm 10,5$	3 MHz E-UTRA signal
UTRA FDD and E-UTRA or E-UTRA with NB-IoT in-band/guard band 5 MHz	$\pm 7,5$	CW
	$\pm 17,5$	5 MHz E-UTRA signal
E-UTRA or E-UTRA with NB-IoT in-band/guard band 10 MHz	$\pm 7,375$	CW
	$\pm 17,5$	5 MHz E-UTRA signal
E-UTRA or E-UTRA with NB-IoT in-band/guard band 15 MHz	$\pm 7,25$	CW
	$\pm 17,5$	5 MHz E-UTRA signal
E-UTRA or E-UTRA with NB-IoT in-band/guard band 20 MHz	$\pm 7,125$	CW
	$\pm 17,5$	5 MHz E-UTRA signal
GSM/EDGE	$\pm 7,575$	CW
	$\pm 17,5$	5 MHz E-UTRA signal
NB-IoT standalone	$\pm 7,575$	CW
	$\pm 17,5$	5 MHz E-UTRA signal
1,28 Mcps UTRA TDD	$\pm 2,3$ (BC3)	CW
	$\pm 5,6$ (BC3)	1,28 Mcps UTRA TDD signal
NR 5 MHz	$\pm 7,5$	CW
	$\pm 17,5$	5 MHz E-UTRA signal
NR 10 MHz	$\pm 7,465$	CW
	$\pm 17,5$	5 MHz E-UTRA signal
NR 15 MHz	$\pm 7,43$	CW
	$\pm 17,5$	5 MHz E-UTRA signal
NR 20 MHz	$\pm 7,395$	CW
	$\pm 17,5$	5 MHz E-UTRA signal
NR 25 MHz	$\pm 7,465$	CW
	± 25	20 MHz E-UTRA signal
NR 30 MHz	$\pm 7,43$	CW
	± 25	20 MHz E-UTRA signal
NR 40 MHz	$\pm 7,4$	CW
	± 25	20 MHz E-UTRA signal
NR 50 MHz	$\pm 7,35$	CW
	± 25	20 MHz E-UTRA signal
NR 60 MHz	$\pm 7,49$	CW
	± 25	20 MHz E-UTRA signal
NR 70 MHz	$\pm 7,42$	CW
	± 25	20 MHz E-UTRA signal
NR 80 MHz	$\pm 7,44$	CW
	± 25	20 MHz E-UTRA signal
NR 90 MHz	$\pm 7,46$	CW
	± 25	20 MHz E-UTRA signal
NR 100 MHz	$\pm 7,48$	CW
	± 25	20 MHz E-UTRA signal

4.2.10.2.2 General narrowband intermodulation limits

Interfering signals shall be a CW signal and an E-UTRA 1RB signal, as specified in annex A of ETSI TS 137 141 [1].

The requirement shall apply outside the Base Station RF bandwidth or Maximum Radio Bandwidth. The interfering signal offset is defined relative to the Base Station RF bandwidth edges or Maximum Radio Bandwidth edges.

For BS operating in non-contiguous spectrum within each supported operating band, the requirement shall apply in addition inside any sub-block gap in case the sub-block gap is at least as wide as the channel bandwidth of the E-UTRA interfering signal in table 4.2.10.2.2-2. The interfering signal offset is defined relative to the sub-block edges inside the gap.

For BS capable of multi-band operation, the requirement shall apply in addition inside any Inter RF bandwidth gap in case the gap size is at least as wide as the E-UTRA interfering signal in table 4.2.10.2.2-2. The interfering signal offset is defined relative to the Base Station RF bandwidth edges inside the Inter RF bandwidth gap.

For the wanted signal at the assigned channel frequency and two interfering signals coupled to the Base Station antenna input, using the parameters in tables 4.2.10.2.2-1 and 4.2.10.2.2-2, the following requirements shall be met:

- For any measured E-UTRA carrier, the throughput shall be ≥ 95 % of the maximum throughput of the reference measurement channel defined in ETSI TS 136 104 [4], clause 7.2.
- For any measured UTRA FDD carrier, the BER shall not exceed 0,001 for the reference measurement channel defined in ETSI TS 125 104 [2], clause 7.2.
- For any measured UTRA TDD carrier, the BER shall not exceed 0,001 for the reference measurement channel defined in ETSI TS 125 105 [3], clause 7.2.
- For any measured GSM/EDGE carrier, the conditions in ETSI TS 145 005 [5], clause P.2.2 shall apply.
- For any measured NB-IoT carrier, the throughput shall be ≥ 95 % of the maximum throughput of the reference measurement channel defined in ETSI TS 136 104 [4], clause 7.2.
- For any measured NR carrier, the throughput shall be ≥ 95 % of the maximum throughput of the reference measurement channel defined in ETSI TS 138 104 [16], clause 7.2.

Table 4.2.10.2.2-1: General narrowband intermodulation requirement

Base Station Type	Mean power of interfering signals [dBm]	Wanted Signal mean power [dBm]	Type of interfering signal
Wide Area BS	-52	$P_{\text{REFSENS}} + x$ dB (see note)	See table 7.7.5.2-2 in ETSI TS 137 141 [1]
Medium Range BS	-47		
Local Area BS	-44		
NOTE: P_{REFSENS} depends on the RAT, the BS class and on the channel bandwidth, see clause 7.2 in ETSI TS 137 141 [1]. "x" is equal to 6 in case of NR, E-UTRA or UTRA wanted signals and equal to 3 in case of GSM/EDGE wanted signal. "x" is specified in table 4.2.10.2.2-1A for NB-IoT.			

Table 4.2.10.2.2-1A: "x" for NB-IoT wanted signals

Operation mode	LTE channel bandwidth for in-band/guard band operation	x
Standalone	-	6
In-band	3 MHz	6
	5 MHz	6
	10 MHz	6
	15 MHz	6
	20 MHz	6
Guard band	5 MHz	6
	10 MHz	6
	15 MHz	6
	20 MHz	6

Table 4.2.10.2.2-2: Interfering signals for narrowband intermodulation requirement

RAT of the carrier adjacent to the high/low edge of the Base Station RF bandwidth or edge of the sub-block	Interfering signal centre frequency offset from the Base Station RF bandwidth edge or edge of sub-block inside a gap [kHz]	Type of interfering signal
E-UTRA 1,4 MHz	± 260 (BC1 and BC3) / ± 270 (BC2)	CW
	± 970 (BC1 and BC3) / ± 790 (BC2)	1,4 MHz E-UTRA signal, 1 RB (note 1)
E-UTRA or E-UTRA with NB-IoT in-band 3 MHz	± 260 (BC1 and BC3) / ± 270 (BC2)	CW
	± 960 (BC1 and BC3) / ± 780 (BC2)	3,0 MHz E-UTRA signal, 1 RB (note 1)
E-UTRA or E-UTRA with NB-IoT in-band/guard band 5 MHz	± 360 (note 3)	CW
	$\pm 1\ 060$	5 MHz E-UTRA signal, 1 RB (note 1)
E-UTRA or E-UTRA with NB-IoT in-band/guard band 10 MHz (note 2)	± 325 (note 3)	CW
	$\pm 1\ 240$	5 MHz E-UTRA signal, 1 RB (note 1)
E-UTRA or E-UTRA with NB-IoT in-band/guard band 15 MHz (note 2)	± 380 (note 3)	CW
	$\pm 1\ 600$	5 MHz E-UTRA signal, 1 RB (note 1)
E-UTRA or E-UTRA with NB-IoT in-band/guard band 20 MHz (note 2)	± 345 (note 3)	CW
	$\pm 1\ 780$	5 MHz E-UTRA signal, 1 RB (note 1)
UTRA FDD	± 345 (BC1 and BC2)	CW
	$\pm 1\ 780$ (BC1 and BC2)	5 MHz E-UTRA signal, 1 RB (note 1)
GSM/EDGE	± 340	CW
	± 880	5 MHz E-UTRA signal, 1 RB (note 1)
NB-IoT standalone	± 340	CW
	± 880	5 MHz E-UTRA signal, 1 RB (note 1)
1,28 Mcps UTRA TDD	± 190 (BC3)	CW
	± 970 (BC3)	1,4 MHz E-UTRA signal, 1 RB (note 1)
NR 5 MHz	± 360	CW
	$\pm 1\ 420$	E-UTRA signal, 1 RB (note 1)
NR 10 MHz	± 370	CW
	$\pm 1\ 960$	E-UTRA signal, 1 RB (note 1)
NR 15 MHz (note 2)	± 380	CW
	$\pm 1\ 960$	E-UTRA signal, 1 RB (note 1)
NR 20 MHz (note 2)	± 390	CW
	$\pm 2\ 320$	E-UTRA signal, 1 RB (note 1)
NR 25 MHz (note 2)	± 325	CW
	$\pm 2\ 350$	E-UTRA signal, 1 RB (note 1)
NR 30 MHz (note 2)	± 335	CW
	$\pm 2\ 350$	E-UTRA signal, 1 RB (note 1)
NR 40 MHz (note 2)	± 355	CW
	$\pm 2\ 710$	E-UTRA signal, 1 RB (note 1)
NR 50 MHz (note 2)	± 375	CW
	$\pm 2\ 710$	E-UTRA signal, 1 RB (note 1)
NR 60 MHz (note 2)	± 395	CW
	$\pm 2\ 710$	E-UTRA signal, 1 RB (note 1)
NR 70 MHz (note 2)	± 415	CW
	$\pm 2\ 710$	E-UTRA signal, 1 RB (note 1)
NR 80 MHz (note 2)	± 435	CW
	$\pm 2\ 710$	E-UTRA signal, 1 RB (note 1)
NR 90 MHz (note 2)	± 365	CW
	$\pm 2\ 530$	E-UTRA signal, 1 RB (note 1)
NR 100 MHz (note 2)	± 385	CW
	$\pm 2\ 530$	E-UTRA signal, 1 RB (note 1)

NOTE 1: Interfering signal consisting of one resource block positioned at the stated offset, the channel bandwidth of the interfering signal is located adjacently to the Base Station RF bandwidth edge or edge of sub-block inside a gap.

RAT of the carrier adjacent to the high/low edge of the Base Station RF bandwidth or edge of the sub-block	Interfering signal centre frequency offset from the Base Station RF bandwidth edge or edge of sub-block inside a gap [kHz]	Type of interfering signal
<p>NOTE 2: This requirement shall apply only for an E-UTRA FRC A1-3 mapped to the frequency range at the channel edge adjacent to the interfering signals.</p> <p>NOTE 3: The frequency offset shall be adjusted to accommodate the IMD product to fall in the NB-IoT RB for NB-IoT in-band/guard band operation.</p> <p>NOTE 4: The frequency offset shall be adjusted to accommodate the IMD product to fall in the NB-IoT RB for NB-IoT in-band/guard band operation.</p> <p>NOTE 5: If a BS RF receiver fails the test of the requirement, the test shall be performed with the CW interfering signal frequency shifted away from the wanted signal by 180 kHz and the E-UTRA interfering signal frequency shifted away from the wanted signal by 360 kHz. If the BS RF receiver still fails the test after the frequency shift, then the BS RF receiver shall be deemed to fail the requirement.</p>		

4.2.10.2.3 Additional narrowband intermodulation limits for GSM/EDGE

The GSM/EDGE MC-BTS receiver intermodulation test requirements stated in applicable parts of clause 4.2.13 in ETSI EN 301 502 [9], shall apply for GSM/EDGE carriers.

The conditions specified in ETSI TS 145 005 [5], clause P.2.2 shall apply for the GSM/EDGE intermodulation requirement.

4.2.10.3 Conformance

Conformance tests described in clause 5.3.9 shall be carried out.

4.2.11 Narrowband blocking

4.2.11.1 Definition

The narrowband blocking characteristics is a measure of the receiver ability to receive a wanted signal at its assigned channel in the presence of an unwanted interferer inside the operating band in the adjacent channel.

Unless otherwise stated, a BS declared to be capable of E-UTRA with NB-IoT in-band and guard band operations (or any combination with GSM and/or UTRA and/or NR) is only required to pass the narrowband blocking tests for E-UTRA with guard band operation (or any combination with GSM and/or UTRA and/or NR). It is not required to perform the in-band selectivity and blocking receiver tests again for E-UTRA with in-band operation (or any combination with GSM and/or UTRA and/or NR).

4.2.11.2 Limits

4.2.11.2.1 General limits

For the narrowband blocking requirement, the interfering signal shall be an E-UTRA 1RB signal as specified in clause A.3 of ETSI TS 137 141 [1].

The requirement shall apply outside of the Base Station RF bandwidth or Maximum Radio Bandwidth. The interfering signal offset is defined relative to the Base Station RF bandwidth edges or Maximum Radio Bandwidth edges.

For BS operating in non-contiguous spectrum, the requirement shall apply in addition inside any sub-block gap, in case the sub-block gap size is at least 3 MHz. The interfering signal offset is defined relative to the sub-block edges inside the sub-block gap.

For BS capable of multi-band operation, the requirement shall apply in addition inside any Inter RF bandwidth gap in case the gap size is at least 3 MHz. The interfering signal offset is defined relative to the Base Station RF bandwidth edges inside the Inter RF bandwidth gap.

For the wanted and interfering signal coupled to the Base Station antenna input, using the parameters in table 4.2.11.2.1-1 the following requirements shall be met:

- For any measured E-UTRA carrier, the throughput shall be ≥ 95 % of the maximum throughput of the reference measurement channel defined in ETSI TS 136 104 [4], clause 7.2.
- For any measured UTRA FDD carrier, the BER shall not exceed 0,001 for the reference measurement channel defined in ETSI TS 125 104 [2], clause 7.2.
- For any measured UTRA TDD carrier, the BER shall not exceed 0,001 for the reference measurement channel defined in ETSI TS 125 105 [3], clause 7.2.
- For any measured GSM/EDGE carrier, the conditions in ETSI TS 145 005 [5], clause P.2.1 shall apply.
- For any measured NB-IoT carrier, the throughput shall be ≥ 95 % of the maximum throughput of the reference measurement channel defined in ETSI TS 136 104 [4], clause 7.2.
- For any measured NR carrier, the throughput shall be ≥ 95 % of the maximum throughput of the reference measurement channel defined in ETSI TS 138 104 [16], clause 7.2.

Table 4.2.11.2.1-1: Narrowband blocking requirement

Base Station Type	RAT of the carrier	Wanted signal mean power [dBm] (see notes 1 and 6)	Interfering signal mean power [dBm]	Interfering RB (see note 2) centre frequency offset from the Base Station RF bandwidth edge or edge of sub-block inside a gap [kHz]
Wide Area BS	NR, E-UTRA, NB-IoT (note 3) UTRA and GSM/EDGE	$P_{\text{REFSENS}} + x$ dB	-49	$\pm(240 + m \times 180)$, M = 0, 1, 2, 3, 4, 9, 14 (note 4) $\pm(550 + m \times 180)$, m=0, 1, 2, 3, 4, 29, 54, 79, 99 (note 5)
Medium Range BS			-44	
Local Area BS			-41	
NOTE 1: P_{REFSENS} depends on the RAT, the BS class and on the channel bandwidth, see clause 7.2 in ETSI TS 137 141 [1]. "x" is equal to 6 in case of NR, E-UTRA or UTRA wanted signals and equal to 3 in case of GSM/EDGE wanted signal. "x" is specified in table 4.2.11.2.1-2 for NB-IoT.				
NOTE 2: Interfering signal (E-UTRA 3 MHz) consisting of one resource block positioned at the stated offset, the channel bandwidth of the interfering signal is located adjacently to the Base Station RF bandwidth edge.				
NOTE 3: For NB-IoT, The mentioned desensitization values "x" consider only one NB-IoT RB in the guard band, which is placed adjacent to the E-UTRA RB edge as close as possible (i.e. away from edge of channel bandwidth).				
NOTE 4: Applicable for <i>channel bandwidths</i> equal to or below 20 MHz.				
NOTE 5: Applicable for <i>channel bandwidths</i> above 20 MHz.				
NOTE 6: 7,5 kHz shift shall not apply to the wanted signal of NR.				
NOTE 7: Void.				

Table 4.2.11.2.1-2: "x" for NB-IoT wanted signals

Operation mode	LTE channel bandwidth for in-band/guard band operation	x
Standalone	-	12
	3 MHz	11
	5 MHz	9
	10 MHz	6
	15 MHz	6
	20 MHz	6
Guard band	5 MHz	13
	10 MHz	6
	15 MHz	6
	20 MHz	6

4.2.11.2.2 Additional limits for GSM/EDGE

The GSM/EDGE in-band blocking test requirements are stated in applicable parts of clause 4.2.12 in ETSI EN 301 502 [9].

The conditions specified in ETSI TS 145 005 [5], clause P.2.1 shall apply for GSM/EDGE in-band narrowband blocking.

4.2.11.2.3 GSM/EDGE limits for AM suppression

The GSM/EDGE in-band blocking test requirements are stated in applicable parts of clause 4.2.14 in ETSI EN 301 502 [9].

The conditions specified in ETSI TS 145 005 [5], clause P.2.3 shall apply for GSM/EDGE AM suppression.

4.2.11.3 Conformance

Conformance tests described in clause 5.3.10 shall be carried out.

4.2.12 Reference sensitivity level

4.2.12.1 Definition

The reference sensitivity power level P_{REFSENS} is the minimum mean power received at the antenna connector at which a reference performance requirement shall be met for a specified reference measurement channel.

The reference sensitivity level requirement is defined separately for each RAT. Additional details are in ETSI TS 138 141-1 [15] clause 7.2, ETSI EN 301 908-14 [7], clause 4.2.14, ETSI EN 301 908-3 [6], clause 4.2.12, ETSI TS 125 142 [13], clause 7.2 and ETSI EN 301 502 [9], clause 4.2.9.

4.2.12.2 Limits

For E-UTRA the limits in ETSI EN 301 908-14 [7], clause 4.2.14.2 shall apply.

For UTRA-FDD the limits in ETSI EN 301 908-3 [6], clause 4.2.12.2 shall apply.

For UTRA-TDD the limits in ETSI TS 125 142 [13], clause 7.2.2 shall apply.

For GSM-EDGE the limits in ETSI EN 301 502 [9], clause 4.2.9.2 shall apply.

For NB-IoT the limits in ETSI EN 301 908-14 [7], clause 4.2.14.2 shall apply.

For NR the limits in ETSI TS 138 141-1 [15], clause 7.2.5 shall apply.

4.2.12.3 Conformance

Conformance tests described in clause 5.3.11 shall be carried out.

5 Testing for compliance with technical requirements

5.1 Environmental conditions for testing

Tests defined in the present document shall be carried out at representative points within the boundary limits of the operational environmental profile defined by its intended use.

Where technical performance varies subject to environmental conditions, tests shall be carried out under a sufficient variety of environmental conditions (within the boundary limits of the operational environmental profile defined by its intended use) to give confidence of compliance for the affected technical requirements.

Normally it should be sufficient for all tests to be conducted using normal test conditions except where otherwise stated. For guidance on the use of other test conditions to be used in order to show compliance reference can be made to ETSI TS 137 141 [1], annex B.

5.2 Void

Table 5.2-1: Void

5.3 Essential radio test suites

5.3.0 Introduction

This clause describes the test suites for MSR Base Stations.

The test configurations that shall be used for demonstrating conformance are specified in clause 5 of ETSI TS 137 141 [1]. Test configurations shall apply according to the declared RAT Capability Set (CS) of the Base Station and the Band Category of the declared operating band (BC1, BC2 or BC3). Transmitter test signals and test models as defined in clause 4.9.2 of ETSI TS 137 141 [1] shall be used.

Many tests in the present document are performed with the maximum Base Station RF bandwidth located at the bottom, middle and top of the supported frequency range in the operating band. These are denoted as B_{RFBW} (bottom), M_{RFBW} (middle) and T_{RFBW} (top) for single band testing and $B_{\text{RFBW}}-T_{\text{RFBW}}$ and $B'_{\text{RFBW}}-T_{\text{RFBW}}$ for multi-band testing, and are defined in clause 4.9.1 of ETSI TS 137 141 [1].

The measurement system required for each test is presented for information in ETSI TS 137 141 [1], annex D.

Unless otherwise stated, a BS declared to be capable of E-UTRA with NB-IoT in-band or guard band operations (or any combination with GSM and/or UTRA) is only required to pass the transmitter and receiver tests for E-UTRA with NB-IoT in-band or guard band (or any combination with GSM and/or UTRA); it is not required to perform the transmitter tests again for E-UTRA only (or any combination with GSM and/or UTRA).

Unless otherwise stated, a BS declared to be capable of E-UTRA with NB-IoT in-band and guard band operations (or any combination with GSM and/or UTRA) needs only to pass the transmitter tests for E-UTRA with guard band operation (or any combination with GSM and/or UTRA).

NB-IoT testing shall be performed with the NB-IoT signal located as described in clause 4.7.3 of ETSI TS 136 141 [11].

5.3.1 Operating band unwanted emissions

5.3.1.0 General

For the operating band unwanted emissions requirement, where the tables with test configurations in clause 5 of ETSI TS 137 141 [1] refer to single-RAT specifications, the following shall apply:

- For references to "TS 25.141", the test suite specified in ETSI EN 301 908-3 [6], clauses 5.3.1.1 and 5.3.1.2 shall be used.
- For references to "TS 25.142", the test suite specified in ETSI TS 125 142 [13], clause 6.6.2.1.4 shall be used.
- For references to "TS 36.141", the test suite specified in ETSI EN 301 908-14 [7], clauses 5.3.1.1 and 5.3.1.2 shall be used.
- For references to "TS 38.141-1", the test suite specified in ETSI TS 138 141-1 [15], clause 6.6.4.4 shall be used.

The test requirements of the present document defined in clause 4.2.2 shall apply.

For GSM/EDGE single-RAT requirements for operating band unwanted emissions, the test suite is specified in applicable parts of clauses 5.3.4.1, 5.3.4.2, 5.3.5.2 and 5.3.8 in ETSI EN 301 502 [9].

For operating band unwanted emissions requirements, where the tables with test configurations in clause 5 of ETSI TS 137 141 [1] refer to the MSR test configurations defined in clause 4.8 of ETSI TS 137 141 [1], the method of test described in clauses 5.3.1.1 and 5.3.1.2 shall apply.

5.3.1.1 Initial conditions

Test environment: normal; see clause B.2 of ETSI TS 137 141 [1].

Base Station RF bandwidth positions to be tested:

- B_{RFBW} , M_{RFBW} and T_{RFBW} in single-band operation; see clause 4.9.1 of ETSI TS 137 141 [1].
- $B_{\text{RFBW}}-T'_{\text{RFBW}}$ and $B'_{\text{RFBW}}-T_{\text{RFBW}}$ in multi-band operation, see clause 4.9.1 of ETSI TS 137 141 [1].

Test set-up:

- 1) Connect the signal analyser to the Base Station antenna connector as shown in clause D.1.1 of ETSI TS 137 141 [1].

As a general rule, the resolution bandwidth of the measuring equipment should be equal to the measurement bandwidth. However, to improve measurement accuracy, sensitivity, efficiency and to avoid e.g. carrier leakage, the resolution bandwidth may be smaller than the measurement bandwidth. When the resolution bandwidth is smaller than the measurement bandwidth, the result should be integrated over the measurement bandwidth in order to obtain the equivalent noise bandwidth of the measurement bandwidth.

- 2) Detection mode: True RMS.

5.3.1.2 Procedure

- 1) Set the Base Station to transmit at maximum power according to the applicable test configuration in clause 5 of ETSI TS 137 141 [1] using the corresponding test models or set of physical channels in clause 4.9.2 of ETSI TS 137 141 [1].
- 2) Step the centre frequency of the measurement filter in contiguous steps and measure the emission within the specified frequency ranges with the specified measurement bandwidth. For BS operating in multiple bands or non-contiguous spectrum, the emission within the Inter RF Bandwidth or sub-block gap shall be measured using the specified measurement bandwidth from the closest RF Bandwidth or sub-block edge.
- 3) Repeat the test for the remaining test cases with channel set-up according to clauses 5 and 4.9.2 of ETSI TS 137 141 [1].

In addition, for a multi-band capable BS, the following step shall apply:

- 4) For multi-band capable BS and single band tests, repeat the steps above per involved band where single band test configurations and test models shall apply with no carrier activated in the other band. For multi-band capable BS with separate antenna connector, the antenna connector not being under test in case of SBT or MBT shall be terminated.

5.3.1.3 Test requirement

The results obtained shall be compared to the limits in clause 4.2.2.2 in order to prove compliance.

5.3.2 Adjacent Channel Leakage power Ratio (ACLR)

5.3.2.0 General

For the ACLR requirement, the tables with test configurations in clause 5 of ETSI TS 137 141 [1] also refer to single-RAT specifications for UTRA. The following shall apply for references to UTRA single-RAT specifications:

- For references to "TS 25.141", the test suite specified in ETSI EN 301 908-3 [6], clauses 5.3.2.1 and 5.3.2.2 shall be used.
- For references to "TS 25.142", the test suite specified in ETSI TS 125 142 [13], clause 6.6.2.4 shall be used.

The results obtained shall be compared to the limits in clause 4.2.3.2 in order to prove compliance.

For NR and E-UTRA ACLR requirement outside the RF bandwidth edges and the ACLR requirement applied inside sub-block gap, in addition, for non-contiguous spectrum operation or Inter RF bandwidth gap for multi-band operation, using the test configurations defined in clause 4.8 of ETSI TS 137 141 [1], the method of test described in clauses 5.3.2.1 and 5.3.2.2 shall apply.

5.3.2.1 Initial conditions

Test environment: normal; see clause B.2 of ETSI TS 137 141 [1].

Base Station RF bandwidth positions to be tested:

- B_{RFBW} , M_{RFBW} and T_{RFBW} in single-band operation; see clause 4.9.1 of ETSI TS 137 141 [1].
- $B_{\text{RFBW}-T_{\text{RFBW}}}$ and $B'_{\text{RFBW}-T_{\text{RFBW}}}$ in multi-band operation, see clause 4.9.1 of ETSI TS 137 141 [1].

Test set-up:

- 1) Connect the signal analyser to the Base Station antenna connector as shown in clause D.1.1 of ETSI TS 137 141 [1].
- 2) The measurement device characteristics shall be:
 - measurement filter bandwidth: defined in clause 4.2.3.2;
 - detection mode: true RMS voltage or true average power.

5.3.2.2 Procedure

- 1) Set the Base Station to transmit at maximum power according to the applicable test configuration in clause 5 of ETSI TS 137 141 [1] using the corresponding test models or set of physical channels in clause 4.9.2 of ETSI TS 137 141 [1].

- 2) For E-UTRA with NB-IoT (in-band and/or guard band operation), measure ACLR outside the RF bandwidth edges and ACLR inside sub-block gap, in addition, for non-contiguous spectrum operation or Inter RF bandwidth gap for multi-band operation, for an assumed 3,84 Mcps adjacent channel UTRA carrier as specified in clause 4.2.3.2.1. For NB-IoT stand-alone operation, measure ACLR as specified in clause 4.2.3.2.5. For NR, measure ACLR outside the Base Station RF Bandwidth edges and ACLR inside sub-block gap or Inter RF Bandwidth gap, in addition, for non-contiguous spectrum operation as specified in clause 4.2.3.2.6.
- 3) For UTRA FDD, measure ACLR inside sub-block gap or Inter RF bandwidth gap as specified in clause 4.2.3.2.2.
- 4) Measure Cumulative Adjacent Channel Leakage power Ratio (CACLR) inside sub-block gap or the Inter RF bandwidth gap as specified in clause 4.2.3.2.4.

In addition, for a multi-band capable BS, the following step shall apply:

- 5) For multi-band capable BS and single band tests, repeat the steps above per involved band where single band test configurations and test models shall apply with no carrier activated in the other band. For multi-band capable BS with separate antenna connector, the antenna connector not being under test in case of SBT or MBT shall be terminated.

5.3.2.3 Test requirement

The results obtained shall be compared to the limits in clause 4.2.3.2.4 in order to prove compliance.

5.3.3 Transmitter spurious emissions

5.3.3.1 Initial conditions

Test environment: normal; see clause B.2 of ETSI TS 137 141 [1].

Base Station RF bandwidth position to be tested:

- B_{RFBW} , M_{RFBW} and T_{RFBW} single-band operation; see clause 4.9.1 of ETSI TS 137 141 [1].
- $B_{\text{RFBW}-T'_{\text{RFBW}}}$ and $B'_{\text{RFBW}-T_{\text{RFBW}}}$ in multi-band operation, see clause 4.9.1 of ETSI TS 137 141 [1].

Test set-up:

- 1) Connect the BS antenna connector to a measurement receiver according to clause D.1.1 of ETSI TS 137 141 [1] using an attenuator or a directional coupler if necessary.
- 2) Measurements shall use a measurement bandwidth in accordance to the conditions in ETSI TS 137 104 [10], clause 6.6.1.
- 3) Detection mode: True RMS.

5.3.3.2 Procedure

- 1) Set the Base Station to transmit at maximum power according to the applicable test configuration in clause 5 of ETSI TS 137 141 [1] using the corresponding test models or set of physical channels in clause 4.9.2 of ETSI TS 137 141 [1].
- 2) Measure the emission at the specified frequencies with specified measurement bandwidth and note that the measured value does not exceed the specified value.

In addition, for a multi-band capable BS, the following step shall apply:

- 3) For multi-band capable BS and single band tests, repeat the steps above per involved band where single band test configurations and test models shall apply with no carrier activated in the other band. For multi-band capable BS with separate antenna connector, the antenna connector not being under test in case of SBT or MBT shall be terminated.

5.3.3.3 Test requirement

The results obtained shall be compared to the limits in clause 4.2.4.2 in order to prove compliance.

5.3.4 Base station maximum output power

5.3.4.1 Initial conditions

Test environment: normal; see clause B.2 of ETSI TS 137 141 [1].

Base Station RF bandwidth positions to be tested:

- B_{RFBW} , M_{RFBW} and T_{RFBW} in single-band operation; see clause 4.9.1 of ETSI TS 137 141 [1]
 $B_{\text{RFBW}}-T_{\text{RFBW}}$.
- $B'_{\text{RFBW}}-T_{\text{RFBW}}$ in multi-band operation, see clause 4.9.1 of ETSI TS 137 141 [1].

In addition, a single test shall be performed under extreme power supply conditions as defined in clause B.5 of ETSI TS 137 141 [1]. In this case, it is sufficient to test on a single combination of one ARFCN, UARFCN, E-ARFCN or NR-ARFCN, one Base Station RF bandwidth position and with only one applicable test configuration defined in clause 5.

NOTE: Tests under extreme power supply also test extreme temperature, see ETSI TS 137 141 [1], clause B.3.1.

Connect the power measuring equipment to the MSR Base Station antenna connector as shown in clause D.1.1 of ETSI TS 137 141 [1].

5.3.4.2 Procedure

- 1) Set the Base Station to transmit at maximum power according to the applicable test configuration in clause 5 of ETSI TS 137 141 [1] using the corresponding test models or set of physical channels in clause 4.9.2 of ETSI TS 137 141 [1].
- 2) Measure the mean power for each carrier at the Base Station antenna connector.

In addition, for a multi-band capable BS, the following step shall apply:

- 3) For multi-band capable BS and single band tests, repeat the steps above per involved band where single band test configurations and test models shall apply with no carrier activated in the other band. For multi-band capable BS with separate antenna connector, the antenna connector not being under test in case of SBT or MBT shall be terminated.

5.3.4.3 Test requirement

The results obtained shall be compared to the limits in clause 4.2.5.2 in order to prove compliance.

5.3.5 Transmit intermodulation

5.3.5.0 General

For the referenced requirements in the present clause, where the tables with test configurations in clause 5 of ETSI TS 137 141 [1] refer to single-RAT specifications, the following shall apply:

- For references to "TS 25.141", the test suite specified in ETSI EN 301 908-3 [6], clauses 5.3.5.1 and 5.3.5.2 shall be used.
- For references to "TS 25.142", the test suite specified in ETSI TS 125 142 [13], clause 6.7.4 shall be used.
- For references to "TS 36.141", the test suite specified in ETSI EN 301 908-14 [7], clauses 5.3.5.1 and 5.3.5.2 shall be used.

- For references to "TS 38.141-1", the test suite specified in ETSI TS 138 141-1 [15], clause 6.7.4 shall be used.

In these four cases the limits of the present document defined in clauses 4.2.2.2, 4.2.3.2 and 4.2.4.2 shall apply.

- For GSM/EDGE single-RAT requirements, the test suite specified in ETSI EN 301 502 [9], applicable parts of clause 5.3.6 shall be used.

In this case the limits defined in the applicable parts of clause 4.2.6.2 in ETSI EN 301 502 [9] shall apply.

5.3.5.1 Initial conditions

Test environment: normal; see clause B.2 of ETSI TS 137 141 [1].

Base Station RF bandwidth position to be tested: according to the initial conditions specified in clauses 5.3.1, 5.3.2 and 5.3.3.

Connect the signal analyser to the Base Station antenna connector as shown in clause D.1.2 of ETSI TS 137 141 [1].

5.3.5.2 Procedure

5.3.5.2.1 General minimum requirement test procedure

- 1) Set the BS to transmit the test signal according to clause 5 of ETSI TS 137 141 [1] at maximum output power according to the applicable test configuration.
- 2) Generate the interfering signal using E-TM1.1 as defined in ETSI TS 136 141 [11], clause 6.1.1.1, with 5 MHz channel bandwidth, at a centre frequency offset according to the conditions in table 4.2.6.2.1-1 but exclude interfering frequencies that are outside of the allocated downlink operating band or interfering frequencies that are not completely within the sub-block gap or within the Inter RF bandwidth gap.
- 3) Adjust ATT1 so that level of the E-UTRA interfering signal is as defined in table 4.2.6.2.1-1.
- 4) If the test signal is applicable according to clause 5 of ETSI TS 137 141 [1], perform the Out-of-band emission tests as specified in clauses 5.3.1 and 5.3.2, for all third and fifth order intermodulation products which appear in the frequency ranges defined in clauses 5.3.1 and 5.3.2. The width of the intermodulation products shall be taken into account.
- 5) If the test signal is applicable according to clause 5 of ETSI TS 137 141 [1], perform the Transmitter spurious emissions test as specified in clause 5.3.3, for all third and fifth order intermodulation products which appear in the frequency ranges defined in clause 5.3.3. The width of the intermodulation products shall be taken into account.
- 6) Verify that the emission level does not exceed the required level with the exception of interfering signal frequencies.
- 7) Repeat the test for the remaining interfering signal centre frequency offsets according to the conditions of table 4.2.6.2.1-1.
- 8) Repeat the test for the remaining test signals defined in clause 5 in ETSI TS 137 141 [1] for requirements clauses 5.3.1, 5.3.2 and 5.3.3.

In addition, for a multi-band capable BS, the following step shall apply:

- 9) For multi-band capable BS and single band tests, repeat the steps above per involved band where single band test configurations and test models shall apply with no carrier activated in the other band. For multi-band capable BS with separate antenna connector, the antenna connector not being under test shall be terminated.

NOTE: The third order intermodulation products are centred at $2F1 \pm F2$ and $2F2 \pm F1$. The fifth order intermodulation products are centred at $3F1 \pm 2F2$, $3F2 \pm 2F1$, $4F1 \pm F2$, and $4F2 \pm F1$ where $F1$ represents the test signal centre frequency or centre frequency of each sub-block gap and $F2$ represents the interfering signal centre frequency. The widths of intermodulation products are:

- $(n \times BW_{F1} + m \times 5 \text{ MHz})$ for the $nF1 \pm mF2$ products;
- $(n \times 5 \text{ MHz} + m \times BW_{F1})$ for the $nF2 \pm mF1$ products;

where BW_{F1} represents the test signal RF bandwidth, or channel bandwidth in case of single carrier, or sub-block bandwidth.

5.3.5.2.2 Additional minimum requirement (BC1 and BC2) test procedure

- 1) Set the BS to transmit the test signal according to clause 5 of ETSI TS 137 141 [1] at maximum output power according to the applicable test configuration.
- 2) Generate a CW signal as the interfering signal with a centre frequency offset of 0,8 MHz, but exclude interfering frequencies that are outside of the allocated downlink operating band or interfering frequencies in a sub-block gap or in the Inter RF bandwidth gap, in case the gap is smaller than two times the interfering signal centre frequency offset.
- 3) Adjust ATT1 so that level of the interfering signal is as defined in table 4.2.6.2.2-1.
- 4) If the test signal is applicable according to clause 5 of ETSI TS 137 141 [1], perform the Out-of-band emission tests as specified in clauses 5.3.1 and 5.3.2, for all third and fifth order intermodulation products which appear in the frequency ranges defined in clauses 5.3.1 and 5.3.2.
- 5) If the test signal is applicable according to clause 5 of ETSI TS 137 141 [1], perform the Transmitter spurious emissions test as specified in clause 5.3.3, for all third and fifth order intermodulation products which appear in the frequency ranges defined in clause 5.3.3.
- 6) Verify that the emission level does not exceed the required level with the exception of interfering signal frequencies.
- 7) Repeat the test for interfering signal centre frequency offsets of 2,0 MHz, 3,2 MHz and 6,2 MHz.
- 8) Repeat the test for the remaining test signals defined in clause 5 of ETSI TS 137 141 [1] for requirements 5.3.1, 5.3.2 and 5.3.3.

In addition, for a multi-band capable BS, the following step shall apply:

- 9) For multi-band capable BS and single band tests, repeat the steps above per involved band where single band test configurations and test models shall apply with no carrier activated in the other band. For multi-band capable BS with separate antenna connector, the antenna connector not being under test shall be terminated.

NOTE: The third order intermodulation products are centred at $2F1 \pm F2$ and $2F2 \pm F1$. The fifth order intermodulation products are centred at $3F1 \pm 2F2$, $3F2 \pm 2F1$, $4F1 \pm F2$, and $4F2 \pm F1$ where $F1$ represents the test signal centre frequency or centre frequency of each sub-block and $F2$ represents the interfering signal centre frequency. The widths of intermodulation products are:

- $(n \times BW_{F1})$ for the $nF1 \pm mF2$ products;
- $(m \times BW_{F1})$ for the $nF2 \pm mF1$ products;

where BW_{F1} represents the test signal RF bandwidth, or channel bandwidth in case of single carrier, or sub-block bandwidth.

5.3.5.2.3 Additional minimum requirement (BC3) test procedure

- 1) Set the BS to transmit the test signal according to clause 5 of ETSI TS 137 141 [1] at maximum output power according to the applicable test configuration.
- 2) Generate the interfering signal according to table 6.38A in ETSI TS 125 142 [13] at a centre frequency offset according to the conditions in table 4.2.6.2.3-1, but exclude interfering frequencies that are outside of the allocated downlink operating band.
- 3) Adjust ATT1 so that level of the interfering signal is as defined in table 4.2.6.2.3-1.
- 4) If the test signal is applicable according to clause 5 of ETSI TS 137 141 [1], perform the Out-of-band emission tests as specified in clauses 5.3.1 and 5.3.2, for all third and fifth order intermodulation products which appear in the frequency ranges defined in clauses 5.3.1 and 5.3.2. The width of the intermodulation products shall be taken into account.
- 5) If the test signal is applicable according to clause 5 of ETSI TS 137 141 [1], perform the Transmitter spurious emissions test as specified in clause 5.3.3 for all third and fifth order intermodulation products which appear in the frequency ranges defined in clause 5.3.3. The width of the intermodulation products shall be taken into account.
- 6) Verify that the emission level does not exceed the required level with the exception of interfering signal frequencies.
- 7) Repeat the test for the remaining interfering signal centre frequency offsets according to the conditions of table 4.2.6.2.3-1.
- 8) Repeat the test for the remaining signal models and physical channels in clause 5 in ETSI TS 137 141 [1].

In addition, for a multi-band capable BS, the following step shall apply:

- 9) For multi-band capable BS and single band tests, repeat the steps above per involved band where single band test configurations and test models shall apply with no carrier activated in the other band. For multi-band capable BS with separate antenna connector, the antenna connector not being under test shall be terminated.

NOTE: The third order intermodulation products are centred at $2F1 \pm F2$ and $2F2 \pm F1$. The fifth order intermodulation products are centred at $3F1 \pm 2F2$, $3F2 \pm 2F1$, $4F1 \pm F2$, and $4F2 \pm F1$ where $F1$ represents the test signal centre frequency or centre frequency of each sub-block and $F2$ represents the interfering signal centre frequency. The widths of intermodulation products are:

- $(n \times BW_{F1} + m \times 1,6 \text{ MHz})$ for the $nF1 \pm mF2$ products;
- $(n \times 1,6 \text{ MHz} + m \times BW_{F1})$ for the $nF2 \pm mF1$ products;

where BW_{F1} represents the test signal RF bandwidth, or channel bandwidth in case of single carrier, or sub-block bandwidth.

5.3.5.3 Test requirement

The results obtained shall be compared to the limits in clause 4.2.6.2 in order to prove compliance.

5.3.6 Receiver spurious emissions

5.3.6.1 Initial conditions

Test environment: normal; see clause B.2 of ETSI TS 137 141 [1].

Base Station RF bandwidth positions to be tested:

- M_{RFBW} in single-band operation, see clause 4.9.1 of ETSI TS 137 141 [1].
- $B_{RFBW-T'_{RFBW}}$ and $B'_{RFBW-T_{RFBW}}$ in multi-band operation, see clause 4.9.1 of ETSI TS 137 141 [1].

Test set-up:

- 1) Set up the equipment as shown in clause D.2.1 of ETSI TS 137 141 [1].

5.3.6.2 Procedure

- 1) Set the measurement equipment parameters as specified in table 4.2.7.2.1-1. For BC2, the parameters in table 4.2.7.2.2-1 shall apply in addition.
- 2) Set the BS to transmit with the carrier set-up and power allocation according to the applicable test configuration(s) (see clause 5 of ETSI TS 137 141 [1]).
- 3) Measure the spurious emissions over each frequency range described in clause 4.2.7.2.

In addition, for a multi-band capable BS, the following step shall apply:

- 4) For multi-band capable BS and single band tests, repeat the steps above per involved band where single band test configurations and test models shall apply with no carrier activated in the other band. For multi-band capable BS with separate antenna connector, the antenna connector not being under test in case of SBT or MBT shall be terminated.

5.3.6.3 Test requirement

The results obtained shall be compared to the limits in clause 4.2.7.2 in order to prove compliance.

5.3.7 In-band blocking

5.3.7.1 Initial conditions

Test environment: normal; see clause B.2 of ETSI TS 137 141 [1].

Base Station RF bandwidth positions to be tested:

- M_{RFBW} in single-band operation, see clause 4.9.1 of ETSI TS 137 141 [1].
- $B_{RFBW-T'_{RFBW}}$ and $B'_{RFBW-T_{RFBW}}$ in multi-band operation, see clause 4.9.1 of ETSI TS 137 141 [1].

Test set-up:

- 1) Set up the equipment as shown in clause D.2.1 of ETSI TS 137 141 [1].
- 2) Generate the wanted signal according to the applicable test configuration (see clause 5 of ETSI TS 137 141 [1]) using applicable reference measurement channel to the BS under test as follows:
 - For E-UTRA see clause A.1 in ETSI TS 136 141 [11].
 - For UTRA FDD see clause A.2 in ETSI TS 125 141 [12].
 - For UTRA TDD see clause A.2.1 in ETSI TS 125 142 [13].
 - For GSM see clause 5.3.12 in ETSI EN 301 502 [9] and annex P in ETSI TS 145 005 [5] for reference channels to test.
 - For NB-IoT see clause A.14 in ETSI TS 136 141 [11].
 - For NR see clause A.1 in ETSI TS 138 141-1 [15].

5.3.7.2 Procedure

5.3.7.2.1 Procedure for general blocking

- 1) Set the BS to transmit with the carrier set-up and power allocation according to the applicable test configuration(s) (see clause 5 of ETSI TS 137 141 [1]).

- 2) Adjust the signal generators to the type of interfering signal, levels and the frequency offsets as specified in table 4.2.8.2.1-1.
- 3) The interfering signal shall be swept with a step size of 1 MHz starting from the minimum offset to the channel edges of the wanted signals as specified in table 4.2.8.2.1-1.
- 4) Measure the performance of the wanted signal at the BS receiver, as defined in clause 4.2.8.2.1, for the relevant carriers specified by the test configuration in clause 4.8 of ETSI TS 137 141 [1].

In addition, for a multi-band capable BS with separate antenna connectors, the following steps shall apply:

- 5) For single band tests, repeat the steps above per involved band where single band test configurations and test models shall apply with no carrier activated in the other band.
- 6) For multiband tests, the interfering signal shall first be applied on the same port as the wanted signal. The test shall be repeated with the interfering signal applied on the other port (if any) mapped to the same receiver as the wanted signal. Any antenna connector with no signal applied shall be terminated.
- 7) Repeat step 6) with the wanted signal for the other(s) bands applied on the respective port(s).

5.3.7.2.2 Procedure for additional BC3 blocking requirement

- 1) Adjust the signal generators to the type of interfering signal, levels and the frequency offsets as specified in table 4.2.8.2.2-1.
- 2) Measure the performance of the wanted signal at the BS receiver, as defined in clause 4.2.8.2.2, for the relevant carriers specified by the test configuration in clause 4.8 of ETSI TS 137 141 [1].

5.3.7.3 Test requirement

The results obtained shall be compared to the limits in clause 4.2.8.2 in order to prove compliance.

5.3.8 Out-of-band blocking

5.3.8.1 Initial conditions

Test environment: normal; see clause B.2 of ETSI TS 137 141 [1].

Base Station RF bandwidth positions to be tested:

- M_{RFBW} in single-band operation, see clause 4.9.1 of ETSI TS 137 141 [1].
- $B_{RFBW-T'_{RFBW}}$ and $B'_{RFBW-T_{RFBW}}$ in multi-band operation, see clause 4.9.1 of ETSI TS 137 141 [1].

In addition, in multi-band operation:

- For $B_{RFBW-T'_{RFBW}}$, out-of-band blocking testing above the highest operating band may be omitted.
- For $B'_{RFBW-T_{RFBW}}$, out-of-band blocking testing below the lowest operating band may be omitted.

Test set-up:

- 1) Set up the equipment as shown in clause D.2.1 of ETSI TS 137 141 [1].
- 2) Generate the wanted signal according the applicable test configuration (see clause 5 of ETSI TS 137 141 [1]) using to reference measurement channel to the BS under test as follows:
 - For E-UTRA see clause A.1 in ETSI TS 136 141 [11].
 - For UTRA FDD see clause A.2 in ETSI TS 125 141 [12].
 - For UTRA TDD see clause A.2.1 in ETSI TS 125 142 [13].

- For GSM see clause 5.3.12 in ETSI EN 301 502 [9] and annex P in ETSI TS 145 005 [5] for reference channels to test. Irrespective of the logical channels supported by the BS under test, the test is performed for GMSK modulated channels only.
- For NB-IoT see clause A.14 in ETSI TS 136 141 [11].
- For NR see clause A.1 in ETSI TS 138 141-1 [15].

5.3.8.2 Procedure

- 1) Set the BS to transmit with the carrier set-up and power allocation according to the applicable test configuration(s) (see clause 5 of ETSI TS 137 141 [1]). The transmitter may be turned off for the out-of-band blocker tests when the frequency of the blocker is such that no IM2 or IM3 products fall inside the bandwidth of the wanted signal.
- 2) Adjust the signal generators to the type of interfering signals, levels and the frequency offsets as specified for the test requirements in table 4.2.9.2-1.
- 3) The CW interfering signal shall be swept with a step size of 1 MHz within the specified range.
- 4) Measure the performance of the wanted signal at the BS receiver, as defined in the clause 4.2.9.2, for the relevant carriers specified by the test configuration in clause 4.8 of ETSI TS 137 141 [1].

In addition, for a multi-band capable BS with separate antenna connectors, the following steps shall apply:

- 5) For single band tests, repeat the steps above per involved band where single band test configurations and test models shall apply with no carrier activated in the other band.
- 6) For multiband tests, the interfering signal shall first be applied on the same port as the wanted signal. The test shall be repeated with the interfering signal applied on the other port (if any) mapped to the same receiver as the wanted signal. Any antenna connector with no signal applied shall be terminated.
- 7) Repeat step 6) with the wanted signal for the other band(s) applied on the respective port(s).

5.3.8.3 Test requirement

The results obtained shall be compared to the limits in clause 4.2.9.2 in order to prove compliance.

5.3.9 Receiver intermodulation characteristics

5.3.9.1 Initial conditions

Test environment: normal; see clause B.2 of ETSI TS 137 141 [1].

Base Station RF bandwidth positions to be tested:

- In single-band operation: M_{RFBW} if TC6 is applicable; B_{RFBW} and T_{RFBW} for other TC, see clause 4.9.1, tables 5.1-1 and 5.2-1 of ETSI TS 137 141 [1].
- In multi- band operation: $B_{\text{RFBW}}-T'_{\text{RFBW}}$ and $B'_{\text{RFBW}}-T_{\text{RFBW}}$, see clause 4.9.1 of ETSI TS 137 141 [1].

Test set-up:

- 1) Set-up the measurement system as shown in clause D.2.3 of ETSI TS 137 141 [1].
- 2) Generate the wanted signal according to the applicable test configuration (see clause 5 of ETSI TS 137 141 [1]) using reference measurement channel to the BS under test as follows:
 - For E-UTRA see clause A.1 in ETSI TS 136 141 [11].
 - For UTRA FDD see clause A.2 in ETSI TS 125 141 [12].
 - For UTRA TDD see clause A.2.1 in ETSI TS 125 142 [13].

- For GSM see clause 5.3.13 in ETSI EN 301 502 [9] and annex P in ETSI TS 145 005 [5] for reference channels to test.
- For NB-IoT see clause A.14 in ETSI TS 136 141 [11].
- For NR see clause A.1 in ETSI TS 138 141-1 [15].

5.3.9.2 Procedure

5.3.9.2.1 Procedure for general and narrowband intermodulation

- 1) Adjust the signal generators to the type of interfering signals, levels and the frequency offsets as specified in tables 4.2.10.2.1-1 and 4.2.10.2.1-2 for the general intermodulation requirement, and tables 4.2.10.2.2-1 and 4.2.10.2.2-2 for the narrowband intermodulation requirement.
- 2) Measure the performance of the wanted signal at the BS receiver, as defined in clauses 4.2.10.2.1 and 4.2.10.2.2, for the relevant carriers specified by the test configuration in clause 4.8 of ETSI TS 137 141 [1].

In addition, for a multi-band capable BS with separate antenna connectors, the following steps shall apply:

- 3) For single band tests, repeat the steps above per involved band where single band test configurations shall apply with no carrier activated in the other band.
- 4) For multiband tests, the interfering signal shall first be applied on the same port as the wanted signal. The test shall be repeated with the interfering signal applied on the other port (if any) mapped to the same receiver as the wanted signal. Any antenna connector with no signal applied shall be terminated.
- 5) Repeat step 4) with the wanted signal for the other band(s) applied on the respective port(s).

5.3.9.2.2 Procedure for additional narrowband intermodulation for GSM/EDGE

5.3.9.2.2.1 General

For a BS declared to support CS1 to CS6 or CS9 to CS13, the GSM/EDGE MC-BTS receiver intermodulation method of test is stated in applicable parts of clause 5.3.13 in ETSI EN 301 502 [9], shall apply for GSM/EDGE carriers.

The conditions specified in ETSI TS 145 005 [5], clause P.2.2 shall apply for the GSM/EDGE intermodulation requirement.

If a BS is declared to support CS7 or CS15, the steps in clauses 5.3.9.2.2.2 and 5.3.9.2.2.3 for testing additional narrowband blocking for GSM/EDGE shall apply:

In addition, for multi-band capable BS and single band tests, repeat the procedure above per involved band where single band test configurations and test models shall apply with no carrier activated in the other band. Any antenna connector with no signal applied shall be terminated.

5.3.9.2.2.2 Initial conditions for additional narrowband intermodulation for GSM/EDGE for CS7 and CS15

Test environment: normal; see clause B.2 of ETSI TS 137 141 [1].

RF bandwidth positions to be tested: M_{RFBW} in single-band operation, see clause 4.9.1 of ETSI TS 137 141 [1]:

- 1) Set up the equipment as shown in clause D.2.3 of ETSI TS 137 141 [1].
- 2) Generate the wanted signal according to the applicable test configuration (see clause 5) using applicable reference measurement channel to the BS under test as follows:
 - For GSM see clause 7.7 in ETSI TS 151 021 [14] and clause P.2.2 in ETSI TS 145 005 [5] for reference channels to test.

5.3.9.2.2.3 Procedure for additional narrowband intermodulation for GSM/EDGE for CS7 and CS15

- 1) Set the BS according to the applicable test configuration(s) (see clause 5 of ETSI TS 137 141 [1]).
- 2) Adjust the GSM/EDGE signal generator to the wanted signal levels as specified in applicable parts of clause 7.7 in ETSI TS 151 021 [14].
- 3) Set-up the interfering signal as specified in applicable parts of clause 7.7 in ETSI TS 151 021 [14].
- 4) Measure the performance of the GSM/EDGE wanted signal at the BS receiver, as defined in applicable parts of clause 7.7 in ETSI TS 151 021 [14].

5.3.9.3 Test requirement

The results obtained shall be compared to the limits in clause 4.2.10.2 in order to prove compliance.

5.3.10 Narrowband blocking

5.3.10.1 Initial conditions

Test environment: normal; see clause B.2 of ETSI TS 137 141 [1].

Base Station RF bandwidth positions to be tested:

- M_{RFBW} in single-band operation, see clause 4.9.1 of ETSI TS 137 141 [1].
- $B_{\text{RFBW-T}}'$ and $B_{\text{RFBW-T}}$ in multi-band operation, see clause 4.9.1 of ETSI TS 137 141 [1].

Test set-up:

- 1) Set up the equipment as shown in clause D.2.1 of ETSI TS 137 141 [1].
- 2) Generate the wanted signal according to the applicable test configuration (see clause 5 of ETSI TS 137 141 [1]) using applicable reference measurement channel to the BS under test as follows:
 - For E-UTRA see clause A.1 in ETSI TS 136 141 [11].
 - For UTRA FDD see clause A.2 in ETSI TS 125 141 [12].
 - For UTRA TDD see clause A.2.1 in ETSI TS 125 142 [13].
 - For GSM see clause 5.3.12 in ETSI EN 301 502 [9] and annex P in ETSI TS 145 005 [5] for reference channels to test.
 - For NB-IoT see clause A.14 in ETSI TS 136 141 [11].
 - For NR see clause A.1 in ETSI TS 138 141-1 [15].

5.3.10.2 Procedure

5.3.10.2.1 Procedure for narrowband blocking

- 1) Set the BS to transmit with the carrier set-up and power allocation according to the applicable test configuration(s) (see clause 5 of ETSI TS 137 141 [1]).
- 2) Adjust the signal generators to the type of interfering signal, levels and the frequency offsets as specified in tables 4.2.11.2.1-1 and 4.2.11.2.1-2.
- 3) Set-up and sweep the interfering RB centre frequency offset to the channel edge of the wanted signal according to tables 4.2.11.2.1-1 and 4.2.11.2.1-2.

- 4) Measure the performance of the wanted signal at the BS receiver, as defined in clause 4.2.11.2.1, for the relevant carriers specified by the test configuration in clause 4.8 of ETSI TS 137 141 [1].

In addition, for a multi-band capable BS with separate antenna connectors, the following steps shall apply:

- 5) For single band tests, repeat the steps above per involved band where single band test configurations and test models shall apply with no carrier activated in the other band.
- 6) For multiband tests, the interfering signal shall first be applied on the same port as the wanted signal. The test shall be repeated with the interfering signal applied on the other port (if any) mapped to the same receiver as the wanted signal. Any antenna connector with no signal applied shall be terminated.
- 7) Repeat step 6) with the wanted signal for the other band(s) applied on the respective port(s).

5.3.10.2.2 Procedure for additional narrowband blocking for GSM/EDGE

5.3.10.2.2.1 General

For a BS declared to support CS1 to CS6 or CS9 to CS13, the GSM/EDGE in-band blocking method of test is stated in applicable parts of clause 5.3.12 in ETSI EN 301 502 [9].

The conditions specified in ETSI TS 145 005 [5], clause P.2.1 shall apply for GSM/EDGE in-band narrowband blocking.

If a BS is declared to support CS7 or CS15, the steps in clauses 5.3.10.2.2.2 and 5.3.10.2.2.3 for testing additional narrowband blocking for GSM/EDGE shall apply:

In addition, for multi-band capable BS and single band tests, repeat the procedure above per involved band where single band test configurations and test models shall apply with no carrier activated in the other band. Any antenna connector with no signal applied shall be terminated.

5.3.10.2.2.2 Initial conditions for additional narrowband blocking for GSM/EDGE for CS7 and CS15

Test environment: normal; see clause B.2 of ETSI TS 137 141 [1].

RF bandwidth positions to be tested: M_{RFBW} in single-band operation, see clause 4.9.1 of ETSI TS 137 141 [1].

- 1) Set up the equipment as shown in clause D.2.1 of ETSI TS 137 141 [1].
- 2) Generate the wanted signal according to the applicable test configuration (see clause 5 of ETSI TS 137 141 [1]) using applicable reference measurement channel to the BS under test as follows:
 - For GSM see clause 7.6.2 in ETSI TS 151 021 [14] and clause P.2.1 in ETSI TS 145 005 [5] for reference channels to test.

5.3.10.2.2.3 Procedure for additional narrowband blocking for GSM/EDGE for CS7 and CS15

- 1) Set the BS according to the applicable test configuration(s) (see clause 5 of ETSI TS 137 141 [1]).
- 2) Adjust the GSM/EDGE signal generator to the wanted signal levels as specified in applicable parts of clause 7.6 in ETSI TS 151 021 [14].
- 3) Set-up the interfering signal as specified in applicable parts of clause 7.6 in ETSI TS 151 021 [14].
- 4) Measure the performance of the GSM/EDGE wanted signal at the BS receiver, as defined in applicable parts of clause 7.6 in ETSI TS 151 021 [14].

5.3.10.2.3 Procedure for GSM/EDGE AM suppression

5.3.10.2.3.1 General

For a BS declared to support CS1 to CS6, the GSM/EDGE in-band blocking method of test is stated in applicable parts of clause 5.3.14 in ETSI EN 301 502 [9].

The conditions specified in ETSI TS 145 005 [5], clause P.2.3 shall apply for GSM/EDGE AM suppression.

If a BS is declared to support CS7, the steps in clauses 5.3.10.2.3.2 and 5.3.10.2.3.3 for testing additional narrowband blocking for GSM/EDGE shall apply:

In addition, for multi-band capable BS and single band tests, repeat the procedure above per involved band where single band test configurations and test models shall apply with no carrier activated in the other band. Any antenna connector with no signal applied shall be terminated.

5.3.10.2.3.2 Initial conditions for GSM/EDGE AM suppression for CS7 and CS15

Test environment: normal; see clause B.2 of ETSI TS 137 141 [1].

RF bandwidth positions to be tested: M_{RFBW} in single-band operation, see clause 4.9.1 of ETSI TS 137 141 [1].

- 1) Set up the equipment as shown in clause D.2.1 of ETSI TS 137 141 [1].
- 2) Generate the wanted signal according to the applicable test configuration (see clause 5 of ETSI TS 137 141 [1]) using applicable reference measurement channel to the BS under test as follows:
 - For GSM see clause 7.8 in ETSI TS 151 021 [14] and clause P.2.3 in ETSI TS 145 005 [5] for reference channels to test.

5.3.10.2.3.3 Procedure for GSM/EDGE AM suppression for CS7 and CS15

- 1) Set the BS according to the applicable test configuration(s) (see clause 5 of ETSI TS 137 141 [1]).
- 2) Adjust the GSM/EDGE signal generator to the wanted signal levels as specified in applicable parts of clause 7.8 in ETSI TS 151 021 [14].
- 3) Set-up the interfering signal as specified in applicable parts of clause 7.8 in ETSI TS 151 021 [14].
- 4) Measure the performance of the GSM/EDGE wanted signal at the BS receiver, as defined in applicable parts of clause 7.8 in ETSI TS 151 021 [14].

5.3.10.3 Test requirement

The results obtained shall be compared to the limits in clause 4.2.11.2 in order to prove compliance.

5.3.11 Reference sensitivity level

5.3.11.1 General

For the Reference sensitivity requirement, the tables with test configurations in clause 5 of ETSI TS 137 141 [1] refer to the single-RAT specifications, for a BS declared to support CS1 to CS6, CS8 to CS14 or CS16 to CS17. The following shall apply, for a BS declared to support CS1 to CS6 or CS16 to CS17:

- For references to "TS 25.141", the test suite specified in ETSI EN 301 908-3 [6], clause 5.3.11 shall be used.
- For references to "TS 25.142", the test suite specified in ETSI TS 125 142 [13], clause 7.2.4 shall be used.
- For references to "TS 36.141", the test suite specified in ETSI EN 301 908-14 [7], clause 5.3.13 shall be used.
- For references to "TS 51.021", the test suite specified in ETSI EN 301 502 [9], clause 5.3.9.
- For references to "TS 38.141-1", the test suite specified in ETSI TS 138 141-1 [15], clause 7.2.4.

If a BS is declared to support CS7 or CS15, the following shall apply:

- For references to "TS 25.141", the test suite specified in ETSI EN 301 908-3 [6], clause 5.3.11 shall be used.
- For references to "TS 36.141", the test suite specified in ETSI EN 301 908-14 [7], clause 5.3.13 shall be used.
- For testing GSM/EDGE reference sensitivity, steps in clauses 5.3.11.1A and 5.3.11.1B shall apply.

In addition, for a multi-band capable BS, the following steps shall apply:

- For multi-band capable BS and single band tests, repeat the tests per involved band where single carrier test models shall apply with no carrier activated in the other band.
- For multi-band capable BS with separate antenna connector, the antenna connector not being under test shall be terminated.

5.3.11.1A Initial conditions for GSM/EDGE reference sensitivity level for CS7 and CS15

Test environment: normal; see clause B.2 of ETSI TS 137 141 [1].

RF bandwidth positions to be tested: M_{RFBW} in single-band operation, see clause 4.9.1 of ETSI TS 137 141 [1].

- 1) Set up the equipment as shown in clause I.2.1 of ETSI TS 136 141 [11].
- 2) Generate the wanted signal according to the applicable test configuration (see clause 5 of ETSI TS 137 141 [1]) using applicable reference measurement channel to the BS under test as follows:
 - For GSM see clauses 7.3 and 7.4 in ETSI TS 151 021 [14] and annex P in ETSI TS 145 005 [5] for reference channels to test.

5.3.11.1B Procedure for GSM/EDGE reference sensitivity level for CS7 and CS15

- 1) Set the BS according to the applicable test configuration(s) (see clause 5 of ETSI TS 137 141 [1]).
- 2) Adjust the GSM/EDGE signal generator to the wanted signal levels as specified in applicable parts of clauses 7.3 and 7.4 in ETSI TS 151 021 [14].
- 3) Measure the performance of the GSM/EDGE wanted signal at the BS receiver, as defined in applicable parts of clauses 7.3 and 7.4 in ETSI TS 151 021 [14].

5.3.11.2 Test requirement

The results obtained shall be compared to the limits in clause 4.2.12 in order to prove compliance.

Annex A (informative): Relationship between the present document and the essential requirements of Directive 2014/53/EU

The present document has been prepared under the Commission's standardisation request C(2015) 5376 final [i.6] to provide one voluntary means of conforming to the essential requirements of Directive 2014/53/EU on the harmonisation of the laws of the Member States relating to the making available on the market of radio equipment and repealing Directive 1999/5/EC [i.1].

Once the present document is cited in the Official Journal of the European Union under that Directive, compliance with the normative clauses of the present document given in table A-1 confers, within the limits of the scope of the present document, a presumption of conformity with the corresponding essential requirements of that Directive and associated EFTA regulations.

Table A-1: Relationship between the present document and the essential requirements of Directive 2014/53/EU

Harmonised Standard ETSI EN 301 908-18					
Requirement				Requirement Conditionality	
No	Description	Essential requirements of Directive	Clause(s) of the present document	U/C	Condition
1	Operating band unwanted emissions	3.2	4.2.2	U	
2	Adjacent Channel Leakage power Ratio (ACLR)	3.2	4.2.3	U	
3	Transmitter spurious emissions	3.2	4.2.4	U	
4	Base station maximum output power	3.2	4.2.5	U	
5	Transmit intermodulation	3.2	4.2.6	U	
6	Receiver spurious emissions	3.2	4.2.7	U	
7	In-band blocking	3.2	4.2.8	U	
8	Out-of-band blocking	3.2	4.2.9	U	
9	Receiver intermodulation characteristics	3.2	4.2.10	U	
10	Narrowband blocking	3.2	4.2.11	U	
11	Reference sensitivity level	3.2	4.2.12	U	

Key to columns:

Requirement:

No A unique identifier for one row of the table which may be used to identify a requirement.

Description A textual reference to the requirement.

Essential requirements of Directive

Identification of article(s) defining the requirement in the Directive.

Clause(s) of the present document

Identification of clause(s) defining the requirement in the present document unless another document is referenced explicitly.

Requirement Conditionality:

U/C Indicates whether the requirement is unconditionally applicable (U) or is conditional upon the manufacturer's claimed functionality of the equipment (C).

Condition Explains the conditions when the requirement is or is not applicable for a requirement which is classified "conditional".

Presumption of conformity stays valid only as long as a reference to the present document is maintained in the list published in the Official Journal of the European Union. Users of the present document should consult frequently the latest list published in the Official Journal of the European Union.

Other Union legislation may be applicable to the product(s) falling within the scope of the present document.

Annex B (normative): Base Station configurations

B.1 Reception with multiple receiver antenna connectors and receiver diversity

For the tests in clause 5, the requirement shall apply at each receiver antenna connector for receivers with antenna diversity or in the case of multi-carrier reception with multiple receiver antenna connectors.

Receiver requirements are tested at the antenna connector, with the remaining receiver(s) disabled or their antenna connector(s) being terminated. If the manufacturer has declared the receiver paths to be equivalent, it is sufficient to apply the specified test signal at any one of the receiver antenna connectors.

For a multi-band BS, multi-band tests for blocking and intermodulation are performed with the interferer(s) applied to each antenna connector mapped to the receiver for the wanted signal(s), however only to one antenna at a time. Antenna connectors to which no signals are applied are terminated.

B.2 Duplexers

The requirements of the present document shall be met with a duplexer fitted, if a duplexer is supplied as part of the BS.

B.3 Power supply options

If the BS is supplied with a number of different power supply configurations, it may not be necessary to test RF parameters for each of the power supply options, provided that it can be demonstrated that the range of conditions over which the equipment is tested is at least as great as the range of conditions due to any of the power supply configurations.

This shall apply particularly if a BS contains a DC rail which can be supplied either externally or from an internal mains power supply. In this case, the conditions of extreme power supply for the mains power supply options can be tested by testing only the external DC supply option. The range of DC input voltages for the test should be sufficient to verify the performance with any of the power supplies, over its range of operating conditions within the BS, including variation of mains input voltage, temperature and output current.

B.4 Ancillary RF amplifiers

The requirements of the present document shall be met with the ancillary RF amplifier fitted, if an ancillary amplifier is part of the base station. At tests according to clause 5, the ancillary amplifier is connected to the BS by a connecting network (including any cable(s), attenuator(s), etc.) with applicable loss to make sure the appropriate operating conditions of the ancillary amplifier and the BS. The applicable connecting network loss range is declared by the manufacturer. Other characteristics and the temperature dependence of the attenuation of the connecting network are neglected. The actual attenuation value of the connecting network is chosen for each test as one of the applicable extreme values. The lowest value is used unless otherwise stated.

Sufficient tests should be repeated with the ancillary amplifier fitted and, if it is optional, without the ancillary RF amplifier to verify that the BS meets the requirements of the present document in both cases.

When testing, the following tests shall be repeated with the optional ancillary amplifier fitted according to table B.4-1, where x denotes that the test shall apply.

Table B.4-1: Tests applicable to Ancillary RF Amplifiers

	Clause	TX amplifier only	RX amplifier only	TX/RX amplifiers combined (see note)
Receiver Tests	5.3.6		X	X
	5.3.7		X	X
	5.3.8		X	X
	5.3.9		X	
	5.3.11		X	X
Transmitter Tests	5.3.1	X		X
	5.3.2	X		X
	5.3.3	X		X
	5.3.4	X		X
	5.3.5	X		X
NOTE: Combining can be by duplex filters or any other network. The amplifiers can either be in RX or TX branch or in both. Either one of these amplifiers could be a passive network.				

In test according to clause 5.3.4 highest applicable attenuation value is applied.

B.5 BS using antenna arrays

B.5.0 General

A BS may be configured with a multiple antenna port connection for some or all of its transceivers or with an antenna array related to one cell (not one array per transceiver). This clause shall apply to a BS which meets at least one of the following conditions:

- the transmitter output signals from one or more transceiver appear at more than one antenna port; or
- there is more than one receiver antenna port for a transceiver or per cell and an input signal is required at more than one port for the correct operation of the receiver thus the outputs from the transmitters as well as the inputs to the receivers are directly connected to several antennas (known as "air combining"); or
- transmitters and receivers are connected via duplexers to more than one antenna.

In case of diversity or spatial multiplexing, multiple antennas are not considered as an antenna array.

If a BS is used, in normal operation, in conjunction with an antenna system which contains filters or active elements which are necessary to meet the E-UTRA requirements, the conformance tests may be performed on a system comprising the BS together with these elements, supplied separately for the purposes of testing. In this case, it shall be demonstrated that the performance of the configuration under test is representative of the system in normal operation, and the conformance assessment is only applicable when the BS is used with the antenna system.

For conformance testing of such a BS, the following procedure may be used.

B.5.1 Receiver tests

For each test, the test signals applied to the receiver antenna connectors shall be such that the sum of the powers of the signals applied equals the power of the test signal(s) specified in the test.

An example of a suitable test configuration is shown in figure B.5.1-1.

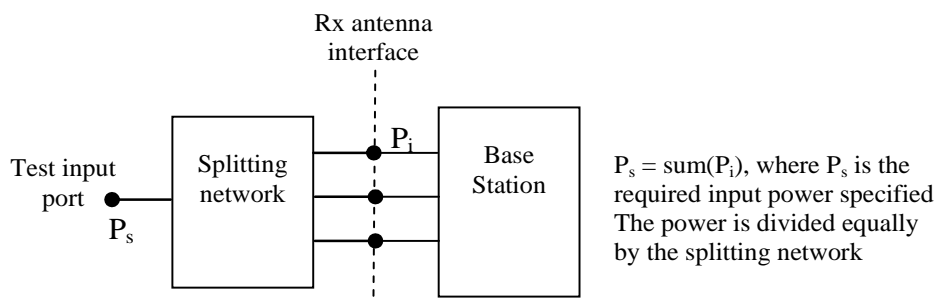

Figure B.5.1-1: Receiver test set-up

For spurious emissions from the receiver antenna connector, the test may be performed separately for each receiver antenna connector.

B.5.2 Transmitter tests

For each test, the test signals applied to the transmitter antenna connectors (P_i) shall be such that the sum of the powers of the signals applied equals the power of the test signal(s) (P_s) specified in the test. This may be assessed by separately measuring the signals emitted by each antenna connector and summing the results, or by combining the signals and performing a single measurement. The characteristics (e.g. amplitude and phase) of the combining network should be such that the power of the combined signal is maximized.

An example of a suitable test configuration is shown in figure B.5.2-1.

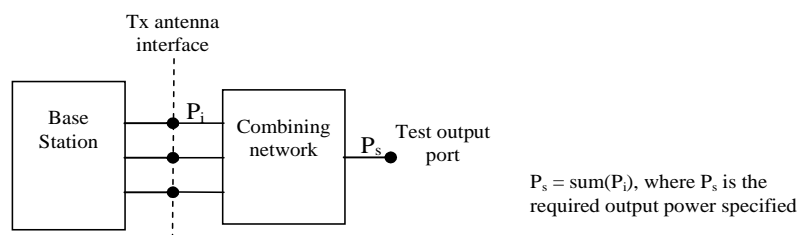

Figure B.5.2-1: Transmitter test set-up

For Intermodulation attenuation, the test may be performed separately for each transmitter antenna connector.

B.6 Transmission with multiple transmitter antenna connectors

Unless otherwise stated, for the tests in clause 5, the requirement shall apply for each transmitter antenna connector in case of transmission with multiple transmitter antenna connectors.

Transmitter requirements are tested at the antenna connector, with the remaining antenna connector(s) being terminated. If the manufacturer has declared the transmitter paths to be equivalent, it is sufficient to measure the signal at any one of the transmitter antenna connectors.

B.7 BS with integrated Iuant BS modem

Unless otherwise stated, for the tests in the present document, the integrated Iuant BS modem shall be switched off. Spurious emissions according to clauses 5.3.3 and 5.3.6 shall be measured only for frequencies above 20 MHz with the integrated Iuant BS modem switched on.

Annex C (informative): Maximum measurement uncertainty

The measurements described in the present document are based on the following assumptions:

- the measured value related to the corresponding limit is used to decide whether an equipment meets the requirements of the present document;
- the value of the measurement uncertainty for the measurement of each parameter is included in the test report.

For the test methods, the recommended values of the maximum measurement uncertainty are calculated and correspond to an expansion factor (coverage factor) $k = 1,96$ (which provides a confidence level of 95 % in the case where the distributions characterizing the actual measurement uncertainties are normal (Gaussian)). Principles for the calculation of measurement uncertainty are contained in ETSI TR 100 028 [i.3], in particular in annex D of the ETSI TR 100 028-2 [i.3].

Table C-1 shows the recommended values for the maximum measurement uncertainty figures.

Table C-1: Maximum measurement uncertainty

Parameter	Condition	Uncertainty
Operating band unwanted emissions	General limits $f \leq 3,0$ GHz $3,0$ GHz $< f \leq 4,2$ GHz Limits for GSM/EDGE single-RAT operation Limits for protection of DTT	$\pm 1,5$ dB $\pm 1,8$ dB (see note 3) $\pm 1,5$ dB
Adjacent Channel Leakage power Ratio (ACLR)	ACLR $BW \leq 20$ MHz $BW > 20$ MHz ACLR absolute power $f \leq 3,0$ GHz $3,0$ GHz $< f \leq 4,2$ GHz	$\pm 0,8$ dB $\pm 1,2$ dB $\pm 2,0$ dB $\pm 2,5$ dB
Cumulative Adjacent Channel Leakage power Ratio (CACLR)	CACLR $BW \leq 20$ MHz $BW > 20$ MHz CACLR absolute power $f \leq 3,0$ GHz $3,0$ GHz $< f \leq 4,2$ GHz	$\pm 0,8$ dB $\pm 1,2$ dB $\pm 2,0$ dB $\pm 2,5$ dB
Transmitter spurious emissions	For "Spurious emissions" and "Additional spurious emissions requirement for BC2" 9 kHz $< f \leq 4$ GHz 4 GHz $< f \leq 19$ GHz For co-existence requirements (> -60 dBm) For co-existence requirements (≤ -60 dBm) For protection of the BS receiver	$\pm 2,0$ dB $\pm 4,0$ dB $\pm 2,0$ dB $\pm 3,0$ dB $\pm 3,0$ dB
Base station maximum output power	For UTRA, E-UTRA and NR $f \leq 3,0$ GHz $3,0$ GHz $< f \leq 4,2$ GHz For GSM/EDGE or standalone NB-IoT	$\pm 0,7$ dB $\pm 1,0$ dB $\pm 1,0$ dB
Transmit intermodulation	For Operating band unwanted emissions For ACLR For "Spurious emissions" and "Additional spurious emissions requirement for BC2": $f \leq 2,2$ GHz $2,2$ GHz $< f \leq 4$ GHz $f > 4$ GHz For co-existence requirements Interfering signal	$\pm 2,5$ dB $\pm 2,2$ dB $\pm 2,5$ dB $\pm 2,8$ dB $\pm 4,5$ dB $\pm 2,8$ dB $\pm 1,0$ dB
Receiver spurious emissions	30 MHz $\leq f \leq 4$ GHz 4 GHz $< f \leq 19$ GHz	$\pm 2,0$ dB $\pm 4,0$ dB
In-band blocking	$f \leq 3,0$ GHz $3,0$ GHz $< f \leq 4,2$ GHz	$\pm 1,4$ dB $\pm 1,8$ dB
Out-of-band blocking	1 MHz $< f_{\text{interferer}} \leq 3$ GHz 3 GHz $< f_{\text{interferer}} \leq 12,75$ GHz	$\pm 1,3$ dB $\pm 3,2$ dB

Parameter	Condition	Uncertainty
Receiver intermodulation characteristics	For general and narrowband intermodulation $f \leq 3,0$ GHz $3,0$ GHz < $f \leq 4,2$ GHz For "Additional narrowband intermodulation limits for GSM/EDGE"	$\pm 1,8$ dB $\pm 2,4$ dB (see note 3)
Narrowband blocking	For general limits $f \leq 3,0$ GHz $3,0$ GHz < $f \leq 4,2$ GHz For "Additional limits for GSM/EDGE" and "GSM/EDGE limits for AM suppression"	$\pm 1,4$ dB $\pm 1,8$ dB (see note 3)
Reference sensitivity level	UTRA, E-UTRA and NB-IoT: $f \leq 3,0$ GHz $3,0$ GHz < $f \leq 4,2$ GHz GSM/EDGE	$\pm 0,7$ dB $\pm 1,0$ dB $\pm 1,0$ dB
<p>NOTE 1: For RF tests, it should be noted that the uncertainties in the table are valid for a test system operating into a nominal 50 Ω load and do not include system effects due to mismatch between the EUT and the Test System.</p> <p>NOTE 2: Annex G of ETSI TR 100 028-2 [i.3] provides guidance for the calculation of the uncertainty components relating to mismatch.</p> <p>NOTE 3: The maximum measurement uncertainty for GSM/EDGE single-RAT requirements included by reference is as defined in ETSI EN 301 502 [9].</p>		

Annex D (informative): Bibliography

- Directive 2014/30/EU of the European Parliament and of the Council of 26 February 2014 on the harmonisation of the laws of the Member States relating to electromagnetic compatibility (recast) (EMC Directive).
- Directive 2014/35/EU of the European Parliament and of the Council of 26 February 2014 on the harmonisation of the laws of the Member States relating to the making available on the market of electrical equipment designed for use within certain voltage limits (recast) (LV Directive).
- CEPT/ERC/REC 74-01 (29 May 2019): "Unwanted Emissions in the Spurious Domain".
- Regulation (EU) No 1025/2012 of the European Parliament and of the Council of 25 October 2012 on European standardisation amending Council Directives 89/686/EEC and 93/15/EEC and Directives 94/9/EC, 94/25/EC, 95/16/EC, 97/23/EC, 98/34/EC, 2004/22/EC, 2007/23/EC, 2009/23/EC and 2009/105/EC of the European Parliament and of the Council and repealing Council Decision 87/95/EEC and Decision No 1673/2006/EC of the European Parliament and of the Council.

Annex E (informative): Change history

Date	Version	Information about changes
2019-01	13.0.1	First draft created from Release 13, including Release 14 and 15 CRs
2019-03	13.0.2	Draft presented to TFES #62
2019-03	13.0.3	Stable draft presented to TFES #62
2019-06	13.0.4	Final draft presented to TFES #63
2019-06	13.0.5	Final draft presented to TFES #63
2019-06	13.0.6	Final draft presented to TFES #63
2019-06	13.0.7	Final draft presented to TFES #63
2019-10	13.0.8	Revised draft using the published v13.1.1 ad baseline, presented to TFES#64
2019-10	13.0.9	Updated draft presented to TFES#64
2019-10	13.0.10	Updated draft presented to TFES#64
2020-09	13.0.11	Updated draft presented to TFES#66
2020-09	13.0.12	Updated draft presented to TFES#66
2020-09	13.0.13	Updated draft presented to TFES#66
2020-09	13.0.14	Updated draft presented to TFES#66
2020-09	13.0.15	Updated draft presented to TFES#66
2020-10	13.0.16	Cleaned-up version submitted for EY assessment
2020-11	13.0.17	Proposed updates based on HAS commetns, presented to TFES#67
2021-03	13.0.18	Updates after HAS comment resolution meeting
2021-03	13.0.19	Corrections during Remote Consensus
2021-05	13.0.20	Corrections before MSG Remote Consensus
2021-09	13.0.21	Correction based on editorial comment from ENAP

History

Document history		
V5.2.1	July 2011	Publication
V6.2.1	November 2012	Publication
V7.1.1	July 2014	Publication
V7.1.2	July 2014	Publication
V11.1.1	July 2016	Publication
V11.1.2	April 2017	Publication
V13.1.1	September 2019	Publication
V15.0.1	June 2021	EN Approval Procedure AP 20210914: 2021-06-16 to 2021-09-14
V15.1.1	September 2021	Publication