

ETSI EN 301 908-18 V11.1.1 (2016-07)



HARMONISED EUROPEAN STANDARD

**IMT cellular networks;
Harmonised Standard covering the essential requirements
of article 3.2 of the Directive 2014/53/EU;
Part 18: E-UTRA, UTRA and GSM/EDGE
Multi-Standard Radio (MSR) Base Station (BS)**

Reference

REN/MSG-TFES-11-18-RED

Keywords

3G, 3GPP, cellular, digital, EDGE, E-UTRA,
GSM, IMT, IMT-2000, IMT-Advanced, LTE,
mobile, MSR, radio, regulation, UMTS, UTRA,
WCDMA

ETSI

650 Route des Lucioles
F-06921 Sophia Antipolis Cedex - FRANCE

Tel.: +33 4 92 94 42 00 Fax: +33 4 93 65 47 16

Siret N° 348 623 562 00017 - NAF 742 C
Association à but non lucratif enregistrée à la
Sous-Préfecture de Grasse (06) N° 7803/88

Important notice

The present document can be downloaded from:
<http://www.etsi.org/standards-search>

The present document may be made available in electronic versions and/or in print. The content of any electronic and/or print versions of the present document shall not be modified without the prior written authorization of ETSI. In case of any existing or perceived difference in contents between such versions and/or in print, the only prevailing document is the print of the Portable Document Format (PDF) version kept on a specific network drive within ETSI Secretariat.

Users of the present document should be aware that the document may be subject to revision or change of status. Information on the current status of this and other ETSI documents is available at
<https://portal.etsi.org/TB/ETSIDeliverableStatus.aspx>

If you find errors in the present document, please send your comment to one of the following services:
<https://portal.etsi.org/People/CommiteeSupportStaff.aspx>

Copyright Notification

No part may be reproduced or utilized in any form or by any means, electronic or mechanical, including photocopying and microfilm except as authorized by written permission of ETSI.

The content of the PDF version shall not be modified without the written authorization of ETSI.
The copyright and the foregoing restriction extend to reproduction in all media.

© European Telecommunications Standards Institute 2016.
All rights reserved.

DECT™, **PLUGTESTS™**, **UMTS™** and the ETSI logo are Trade Marks of ETSI registered for the benefit of its Members.
3GPP™ and **LTE™** are Trade Marks of ETSI registered for the benefit of its Members and of the 3GPP Organizational Partners.
GSM® and the GSM logo are Trade Marks registered and owned by the GSM Association.

Contents

Intellectual Property Rights	6
Foreword.....	6
Modal verbs terminology.....	6
Introduction	6
1 Scope	7
2 References	7
2.1 Normative references	7
2.2 Informative references.....	9
3 Definitions, symbols and abbreviations	9
3.1 Definitions.....	9
3.2 Symbols.....	12
3.3 Abbreviations	12
4 Technical requirements specifications	14
4.1 Environmental profile.....	14
4.2 Conformance requirements	14
4.2.1 Introduction.....	14
4.2.2 Operating band unwanted emissions	17
4.2.2.1 Definition	17
4.2.2.2 Limits	17
4.2.2.2.1 Limits for Band Categories 1 and 3.....	17
4.2.2.2.2 Limits for Band Category 2.....	22
4.2.2.2.3 Limits for GSM/EDGE single-RAT operation.....	27
4.2.2.2.4 Limits for protection of DTT.....	28
4.2.2.2.5 Limits for co-existence with services in adjacent frequency bands.....	28
4.2.2.2.6 Limits for operation in Band 32	28
4.2.2.3 Conformance.....	29
4.2.3 Adjacent Channel Leakage power Ratio (ACLR)	29
4.2.3.1 Definition	29
4.2.3.2 Limits	29
4.2.3.2.1 E-UTRA limits	29
4.2.3.2.2 UTRA FDD limits	29
4.2.3.2.3 UTRA TDD limits.....	30
4.2.3.2.4 Cumulative ACLR requirement in non-contiguous spectrum	30
4.2.3.3 Conformance.....	31
4.2.4 Transmitter spurious emissions.....	31
4.2.4.1 Definition	31
4.2.4.2 Limits	32
4.2.4.2.1 Spurious emissions	32
4.2.4.2.2 Additional spurious emissions requirement for BC2.....	32
4.2.4.2.3 Co-existence with other systems	32
4.2.4.2.4 Protection of the BS receiver of own or different BS.....	34
4.2.4.3 Conformance.....	34
4.2.5 Base station maximum output power.....	34
4.2.5.1 Definition	34
4.2.5.2 Limits	35
4.2.5.3 Conformance.....	35
4.2.6 Transmit intermodulation	35
4.2.6.1 Definition	35
4.2.6.2 Limits	35
4.2.6.2.1 General limits	35
4.2.6.2.2 Additional limits (BC1 and BC2).....	36
4.2.6.2.3 Additional limits (BC3).....	36
4.2.6.3 Conformance.....	37
4.2.7 Receiver spurious emissions	37

4.2.7.1	Definition	37
4.2.7.2	Limits	37
4.2.7.2.1	General limits	37
4.2.7.2.2	Additional limits for BC2	38
4.2.7.3	Conformance	38
4.2.8	In-band blocking	38
4.2.8.1	Definition	38
4.2.8.2	Limits	38
4.2.8.2.1	General limits	38
4.2.8.2.2	Additional BC3 blocking limits	40
4.2.8.3	Conformance	40
4.2.9	Out-of-band blocking	40
4.2.9.1	Definition	40
4.2.9.2	Limits	40
4.2.9.3	Conformance	41
4.2.10	Receiver intermodulation characteristics	41
4.2.10.1	Definition	41
4.2.10.2	Limits	41
4.2.10.2.1	General intermodulation limits	41
4.2.10.2.2	General narrowband intermodulation limits	42
4.2.10.2.3	Additional narrowband intermodulation limits for GSM/EDGE	44
4.2.10.3	Conformance	44
4.2.11	Narrowband blocking	44
4.2.11.1	Definition	44
4.2.11.2	Limits	44
4.2.11.2.1	General limits	44
4.2.11.2.2	Additional limits for GSM/EDGE	45
4.2.11.2.3	GSM/EDGE limits for AM suppression	45
4.2.11.3	Conformance	45
4.2.12	Reference sensitivity level	45
4.2.12.1	Definition	45
4.2.12.2	Limits	45
4.2.12.3	Conformance	46
5	Testing for compliance with technical requirements	46
5.1	Environmental conditions for testing	46
5.2	Interpretation of the measurement results	46
5.3	Essential radio test suites	48
5.3.0	Introduction	48
5.3.1	Operating band unwanted emissions	48
5.3.1.0	General	48
5.3.1.1	Initial conditions	48
5.3.1.2	Procedure	49
5.3.1.3	Test requirement	49
5.3.2	Adjacent Channel Leakage power Ratio (ACLR)	49
5.3.2.0	General	49
5.3.2.1	Initial conditions	49
5.3.2.2	Procedure	50
5.3.2.3	Test requirement	50
5.3.3	Transmitter spurious emissions	50
5.3.3.1	Initial conditions	50
5.3.3.2	Procedure	50
5.3.3.3	Test requirement	51
5.3.4	Base station maximum output power	51
5.3.4.1	Initial conditions	51
5.3.4.2	Procedure	51
5.3.4.3	Test requirement	51
5.3.5	Transmit intermodulation	51
5.3.5.0	General	51
5.3.5.1	Initial conditions	52
5.3.5.2	Procedure	52
5.3.5.2.1	General minimum requirement test procedure	52

5.3.5.2.2	Additional minimum requirement (BC1 and BC2) test procedure	53
5.3.5.2.3	Additional minimum requirement (BC3) test procedure	54
5.3.5.3	Test requirement	54
5.3.6	Receiver spurious emissions	54
5.3.6.1	Initial conditions	54
5.3.6.2	Procedure	55
5.3.6.3	Test requirement	55
5.3.7	In-band blocking	55
5.3.7.1	Initial conditions	55
5.3.7.2	Procedure	55
5.3.7.2.1	Procedure for general blocking	55
5.3.7.2.2	Procedure for additional BC3 blocking requirement	56
5.3.7.3	Test requirement	56
5.3.8	Out-of-band blocking	56
5.3.8.1	Initial conditions	56
5.3.8.2	Procedure	57
5.3.8.3	Test requirement	57
5.3.9	Receiver intermodulation characteristics	57
5.3.9.1	Initial conditions	57
5.3.9.2	Procedure	58
5.3.9.2.1	Procedure for general and narrowband intermodulation	58
5.3.9.2.2	Procedure for additional narrowband intermodulation for GSM/EDGE	58
5.3.9.3	Test requirement	58
5.3.10	Narrowband blocking	58
5.3.10.1	Initial conditions	58
5.3.10.2	Procedure	59
5.3.10.2.1	Procedure for narrowband blocking	59
5.3.10.2.2	Procedure for additional narrowband blocking for GSM/EDGE	59
5.3.10.2.3	Procedure for GSM/EDGE AM suppression	59
5.3.10.3	Test requirement	59
5.3.11	Reference sensitivity level	60
5.3.11.1	General	60
5.3.11.2	Test requirement	60
Annex A (normative):	Relationship between the present document and the essential requirements of Directive 2014/53/EU	61
Annex B (normative):	Base Station configurations	62
B.1	Reception with multiple receiver antenna connectors and receiver diversity	62
B.2	Duplexers	62
B.3	Power supply options	62
B.4	Ancillary RF amplifiers	62
B.5	BS using antenna arrays	63
B.5.0	General	63
B.5.1	Receiver tests	63
B.5.2	Transmitter tests	64
B.6	Transmission with multiple transmitter antenna connectors	64
B.7	BS with integrated Iuant BS modem	64
Annex C (informative):	Environmental profile specification	65
Annex D (informative):	Bibliography	66
History	67

Intellectual Property Rights

IPRs essential or potentially essential to the present document may have been declared to ETSI. The information pertaining to these essential IPRs, if any, is publicly available for **ETSI members and non-members**, and can be found in ETSI SR 000 314: "*Intellectual Property Rights (IPRs); Essential, or potentially Essential, IPRs notified to ETSI in respect of ETSI standards*", which is available from the ETSI Secretariat. Latest updates are available on the ETSI Web server (<https://ipr.etsi.org>).

Pursuant to the ETSI IPR Policy, no investigation, including IPR searches, has been carried out by ETSI. No guarantee can be given as to the existence of other IPRs not referenced in ETSI SR 000 314 (or the updates on the ETSI Web server) which are, or may be, or may become, essential to the present document.

Foreword

This Harmonised European Standard (EN) has been produced by ETSI Technical Committee Mobile Standards Group (MSG).

For non EU countries the present document may be used for regulatory (Type Approval) purposes.

The present document has been prepared under the Commission's standardisation request C(2015) 5376 final [i.6] to provide one voluntary means of conforming to the essential requirements of Directive 2014/53/EU on the harmonisation of the laws of the Member States relating to the making available on the market of radio equipment and repealing Directive 1999/5/EC [i.1].

Once the present document is cited in the Official Journal of the European Union under that Directive, compliance with the normative clauses of the present document given in table A-1 confers, within the limits of the scope of the present document, a presumption of conformity with the corresponding essential requirements of that Directive and associated EFTA regulations.

The present document is part 18 of a multi-part deliverable. Full details of the entire series can be found in part 1 [i.4].

National transposition dates	
Date of adoption of this EN:	12 July 2016
Date of latest announcement of this EN (doa):	31 October 2016
Date of latest publication of new National Standard or endorsement of this EN (dop/e):	30 April 2017
Date of withdrawal of any conflicting National Standard (dow):	30 April 2018

Modal verbs terminology

In the present document "**shall**", "**shall not**", "**should**", "**should not**", "**may**", "**need not**", "**will**", "**will not**", "**can**" and "**cannot**" are to be interpreted as described in clause 3.2 of the [ETSI Drafting Rules](#) (Verbal forms for the expression of provisions).

"**must**" and "**must not**" are **NOT** allowed in ETSI deliverables except when used in direct citation.

Introduction

The present document is part of a set of standards developed by ETSI that are designed to fit in a modular structure to cover radio equipment within the scope of the Radio Equipment Directive [i.1]. The present document is produced following the guidance in ETSI EG 203 336 [i.2] as applicable.

1 Scope

The present document applies to the following equipment types:

- 1) Multi-Standard Radio capable Base stations (E-UTRA, UTRA, GSM/EDGE).

These radio equipment types are capable of operating in all or any part of the frequency bands given in table 1-1.

Table 1-1: Base station operating bands

Band designation and Band Category	Direction of transmission	MSR Base Station operating bands
1 (BC1)	Transmit	2 110 MHz to 2 170 MHz
	Receive	1 920 MHz to 1 980 MHz
3 (BC2)	Transmit	1 805 MHz to 1 880 MHz
	Receive	1 710 MHz to 1 785 MHz
7 (BC1)	Transmit	2 620 MHz to 2 690 MHz
	Receive	2 500 MHz to 2 570 MHz
8 (BC2)	Transmit	925 MHz to 960 MHz
	Receive	880 MHz to 915 MHz
20 (BC1)	Transmit	791 MHz to 821 MHz
	Receive	832 MHz to 862 MHz
22 (BC1)	Transmit	3 510 MHz to 3 590 MHz
	Receive	3 410 MHz to 3 490 MHz
28 (BC1)	Transmit	758 MHz to 803 MHz
	Receive	703 MHz to 748 MHz
32 (BC1) (note)	Transmit	1 452 MHz to 1 496 MHz
	Receive	N/A
33 (BC3)	Transmit and Receive	1 900 MHz to 1 920 MHz
34 (BC3)	Transmit and Receive	2 010 MHz to 2 025 MHz
38 (BC3)	Transmit and Receive	2 570 MHz to 2 620 MHz
40 (BC3)	Transmit and Receive	2 300 MHz to 2 400 MHz
42 (BC3)	Transmit and Receive	3 400 MHz to 3 600 MHz
43 (BC3)	Transmit and Receive	3 600 MHz to 3 800 MHz
NOTE: Restricted to E-UTRA operation when carrier aggregation is configured. The downlink operating band is paired with the uplink operating band (external) of the carrier aggregation configuration that is supporting the configured Pcell. Restricted to UTRA operation when dual band is configured (e.g. DB-DC-HSDPA or dual band 4C-HSDPA). The down link frequency(ies) of this band are paired with the uplink frequency(ies) of the other FDD band (external) of the dual band configuration.		

NOTE: For BS capable of multi-band operation, the supported operating bands may belong to different Band Categories.

The present document covers requirements for multi-RAT capable E-UTRA, UTRA and GSM/EDGE MSR Base Stations for 3GPP™ Release 9, 10 and 11. This includes the requirements for E UTRA Base Station operating bands and E-UTRA CA operating bands from 3GPP Release 12.

The present document contains requirements to demonstrate that Radio equipment both effectively uses and supports the efficient use of radio spectrum in order to avoid harmful interference.

2 References

2.1 Normative references

References are either specific (identified by date of publication and/or edition number or version number) or non-specific. For specific references, only the cited version applies. For non-specific references, the latest version of the referenced document (including any amendments) applies.

Referenced documents which are not found to be publicly available in the expected location might be found at <http://docbox.etsi.org/Reference>.

NOTE: While any hyperlinks included in this clause were valid at the time of publication, ETSI cannot guarantee their long term validity.

The following referenced documents are necessary for the application of the present document.

- [1] ETSI TS 137 141 (V11.13.0) (01-2016): "Digital cellular telecommunications system (Phase 2+); Universal Mobile Telecommunications System (UMTS); LTE; E-UTRA, UTRA and GSM/EDGE; Multi-Standard Radio (MSR) Base Station (BS) conformance testing (3GPP TS 37.141 version 11.13.0 Release 11)".
- [2] ETSI TS 125 104 (V11.12.0) (01-2016): "Universal Mobile Telecommunications System (UMTS); Base Station (BS) radio transmission and reception (FDD) (3GPP TS 25.104 version 11.12.0 Release 11)".
- [3] ETSI TS 125 105 (V11.9.0) (01-2016): "Universal Mobile Telecommunications System (UMTS); Base Station (BS) radio transmission and reception (TDD) (3GPP TS 25.105 version 11.9.0 Release 11)".
- [4] ETSI TS 136 104 (V11.14.0) (01-2016): "LTE; Evolved Universal Terrestrial Radio Access (E-UTRA); Base Station (BS) radio transmission and reception (3GPP TS 36.104 version 11.14.0 Release 11)".
- [5] ETSI TS 145 005 (V11.4.0) (01-2014): "Digital cellular telecommunications system (Phase 2+); Radio transmission and reception (3GPP TS 45.005 version 11.4.0 Release 11)".
- [6] ETSI EN 301 908-3 (V11.1.2) (07-2016): "IMT cellular networks; Harmonised Standard covering the essential requirements of article 3.2 of the Directive 2014/53/EU; Part 3: CDMA Direct Spread (UTRA FDD) Base Stations (BS)".
- [7] ETSI EN 301 908-14 (V11.1.1) (05-2016): "IMT cellular networks; Harmonised Standard covering the essential requirements of article 3.2 of the Radio Equipment Directive 2014/53/EU; Part 14: Evolved Universal Terrestrial Radio Access (E-UTRA) Base Stations (BS)".
- [8] ETSI TS 136 104 (V12.10.0) (01-2016): "LTE; Evolved Universal Terrestrial Radio Access (E-UTRA); Base Station (BS) radio transmission and reception (3GPP TS 36.104 version 12.10.0 Release 12)".
- [9] ETSI EN 301 502 (V12.5.1) (07-2016): "Global System for Mobile communications (GSM); Base Station (BS) equipment; Harmonised Standard covering the essential requirements of article 3.2 of the Directive 2014/53/EU".
- [10] ETSI TS 137 104 (V11.13.0) (01-2016): "Digital cellular telecommunications system (Phase 2+); Universal Mobile Telecommunications System (UMTS); LTE; E-UTRA, UTRA and GSM/EDGE; Multi-Standard Radio (MSR) Base Station (BS) radio transmission and reception (3GPP TS 37.104 version 11.13.0 Release 11)".
- [11] ETSI TS 136 141 (V11.14.0) (01-2016): "LTE; Evolved Universal Terrestrial Radio Access (E-UTRA); Base Station (BS) conformance testing (3GPP TS 36.141 version 11.14.0 Release 11)".
- [12] ETSI TS 125 141 (V11.12.0) (01-2016): "Universal Mobile Telecommunications System (UMTS); Base Station (BS) conformance testing (FDD) (3GPP TS 25.141 version 11.12.0 Release 11)".
- [13] ETSI TS 125 142 (V11.5.0) (01-2016): "Universal Mobile Telecommunications System (UMTS); Base Station (BS) conformance testing (TDD) (3GPP TS 25.142 version 11.5.0 Release 11)".
- [14] ETSI TS 151 021 (V11.4.0) (10-2013): "Digital cellular telecommunications system (Phase 2+); Base Station System (BSS) equipment specification; Radio aspects (3GPP TS 51.021 version 11.4.0 Release 11)".

2.2 Informative references

References are either specific (identified by date of publication and/or edition number or version number) or non-specific. For specific references, only the cited version applies. For non-specific references, the latest version of the referenced document (including any amendments) applies.

NOTE: While any hyperlinks included in this clause were valid at the time of publication, ETSI cannot guarantee their long term validity.

The following referenced documents are not necessary for the application of the present document but they assist the user with regard to a particular subject area.

- [i.1] Directive 2014/53/EU of the European parliament and of the council of 16 April 2014 on the harmonisation of the laws of the Member States relating to the making available on the market of radio equipment and repealing Directive 1999/5/EC.
- [i.2] ETSI EG 203 336 (V1.1.1) (08-2015): "Electromagnetic compatibility and Radio spectrum Matters (ERM); Guide for the selection of technical parameters for the production of Harmonised Standards covering article 3.1(b) and article 3.2 of Directive 2014/53/EU".
- [i.3] ETSI TR 100 028 (all parts) (V1.4.1): "Electromagnetic compatibility and Radio spectrum Matters (ERM); Uncertainties in the measurement of mobile radio equipment characteristics".
- [i.4] ETSI EN 301 908-1 (V11.1.1): "IMT cellular networks; Harmonised Standard covering the essential requirements of article 3.2 of the Directive 2014/53/EU; Part 1: Introduction and common requirements".
- [i.5] Recommendation ITU-R SM.329-12 (09-2012): "Unwanted emissions in the spurious domain".
- [i.6] Commission Implementing Decision C(2015) 5376 final of 4.8.2015 on a standardisation request to the European Committee for Electrotechnical Standardisation and to the European Telecommunications Standards Institute as regards radio equipment in support of Directive 2014/53/EU of the European Parliament and of the Council.

3 Definitions, symbols and abbreviations

3.1 Definitions

For the purposes of the present document, the following terms and definitions apply:

band category: group of operating bands for which the same MSR scenarios apply

NOTE: The band categories for MSR BS are defined in clause 4.4 of ETSI TS 137 141 [1] and are listed in table 1-1.

Base Station class: wide area Base Station, medium range Base Station or local Area Base Station, as declared by the manufacturer

Base Station RF bandwidth: bandwidth in which a Base Station transmits and/or receives single or multiple carrier(s) and/or RATs simultaneously within a supported operating band

NOTE: In single carrier operation, the Base Station RF bandwidth is equal to the channel bandwidth.

Base Station RF bandwidth edge: frequency of one of the edges of the Base Station RF bandwidth

carrier: modulated waveform conveying the E-UTRA, UTRA or GSM/EDGE physical channels

carrier aggregation: aggregation of two or more E-UTRA component carriers in order to support wider transmission bandwidths

carrier aggregation band: set of one or more operating bands across which multiple E-UTRA carriers are aggregated with a specific set of technical requirements

NOTE: Carrier aggregation band(s) for an E-UTRA BS is declared by the manufacturer according to the designations in tables 4.2.1-2 to 4.2.1-5.

carrier power: power at the antenna connector in the channel bandwidth of the carrier averaged over at least one subframe for E-UTRA, at least one slot for UTRA and the useful part of the burst for GSM/EDGE

channel bandwidth: RF bandwidth supporting a single E-UTRA, UTRA or GSM/EDGE RF carrier

NOTE: The channel bandwidth is measured in MHz and is used as a reference for transmitter and receiver RF requirements.

configured carrier power: target maximum power for a specific carrier for the operating mode set in the BS

contiguous spectrum: spectrum consisting of a contiguous block of spectrum with no sub-block gap(s)

downlink operating band: part of the operating band designated for downlink

Inter RF bandwidth gap: frequency gap between two consecutive Base Station RF bandwidths that are placed within two supported operating bands

inter-band gap: frequency gap between two supported consecutive operating bands

intra-band contiguous carrier aggregation: contiguous E-UTRA carriers aggregated in the same operating band

local area Base Station: Base Stations characterized by requirements derived from picocell scenarios with a BS to UE minimum coupling loss equal to 45 dB

lower Base Station RF bandwidth edge: frequency of the lower edge of the Base Station RF bandwidth, used as a frequency reference point for transmitter and receiver requirements

lower sub-block edge: frequency at the lower edge of one sub-block

NOTE: It is used as a frequency reference point for both transmitter and receiver requirements.

maximum Base Station RF bandwidth: maximum RF bandwidth supported by a Base Station within each supported operating band

NOTE: The Maximum Base Station RF bandwidth for BS configured for contiguous and non-contiguous operation within each supported operating band is declared separately.

maximum carrier output power: carrier power available at the antenna connector for a specified reference condition

Maximum Radio Bandwidth: maximum frequency difference between the upper edge of the highest used carrier and the lower edge of the lowest used carrier

maximum throughput: maximum achievable throughput for a reference measurement channel

maximum total output power: sum of the power of all carriers available at the antenna connector for a specified reference condition

MB-MSR Base Station: MSR Base Station characterized by the ability of its transmitter and/or receiver to process two or more carriers in common active RF components simultaneously, where at least one carrier is configured at a different non-overlapping operating band than the other carrier(s)

mean power: power measured in the bandwidth and period of measurement applicable for each RAT

NOTE: Mean power for an E-UTRA carrier is defined in ETSI TS 136 141 [11] and mean power for a UTRA carrier is defined in ETSI TS 125 141 [12]. In case of multiple carriers, the mean power is the sum of the mean power of all carriers.

measurement bandwidth: bandwidth in which an emission level is specified

medium range Base Station: Base Stations characterized by requirements derived from micro cell scenarios with a BS to UE minimum coupling loss equal to 53 dB

MSR Base Station (BS): Base Station characterized by the ability of its receiver and transmitter to process two or more carriers in common active RF components simultaneously in a declared Base Station RF bandwidth, where at least one carrier is of a different RAT than the other carrier(s)

multi-band receiver: receiver characterized by the ability to process two or more carriers in common active RF components simultaneously, where at least one carrier is configured at a different non-overlapping operating band than the other carrier(s)

multi-band transmitter: transmitter characterized by the ability to process two or more carriers in common active RF components simultaneously, where at least one carrier is configured at a different non-overlapping operating band than the other carrier(s)

non-contiguous spectrum: spectrum consisting of two or more sub-blocks separated by sub-block gap(s)

operating band: frequency range in which E-UTRA, UTRA or GSM/EDGE operates (paired or unpaired), that is defined with a specific set of technical requirements

NOTE: The operating band(s) for a Base Station is declared by the manufacturer. Operating bands have designations according to table 1-1.

single-RAT operation: operation of a Base Station in an operating band with only one RAT configured in that operating band

sub-block: contiguous allocated block of spectrum for use by the same Base Station

NOTE: There may be multiple instances of sub-blocks within a Base Station RF bandwidth.

sub-block bandwidth: bandwidth of one sub-block

sub-block gap: frequency gap between two consecutive sub-blocks within a Base Station RF bandwidth, where the RF requirements in the gap are based on co-existence for un-coordinated operation

throughput: number of payload bits successfully received per second for a reference measurement channel in a specified reference condition

total RF bandwidth: maximum sum of Base Station RF bandwidths in all supported operating bands

transmission bandwidth: bandwidth of an instantaneous E-UTRA transmission from a UE or BS, measured in Resource Block units

transmitter OFF period: time period during which the BS transmitter is not allowed to transmit

transmitter ON period: time period during which the BS transmitter is transmitting data and/or reference symbols, e.g. data subframes or DwPTS

transmitter transient period: time period during which the transmitter is changing from the OFF period to the ON period or vice versa

uplink operating band: part of the operating band designated for uplink

upper Base Station RF bandwidth edge: frequency of the upper edge of the Base Station RF bandwidth, used as a frequency reference point for transmitter and receiver requirements

upper sub-block edge: frequency at the upper edge of one sub-block

NOTE: It is used as a frequency reference point for both transmitter and receiver requirements.

wide area Base Station: Base Stations characterized by requirements derived from macro cell scenarios with a BS to UE minimum coupling loss equal to 70 dB

NOTE: This Base Station class has the same requirements as the general purpose Base Station in the sixth release version of the present document, corresponding to 3GPP Release 8.

3.2 Symbols

For the purposes of the present document, the following symbols apply:

BW_{RF}	Base Station RF bandwidth, where $BW_{RF} = F_{BW\ RF,high} - F_{BW\ RF,low}$
B_{RFBW}	Maximum Base Station RF bandwidth located at the bottom of the supported frequency range in the operating band
CA_X	CA for band X where X is the applicable E-UTRA operating band
f	Frequency
Δf	Separation between the Base Station RF bandwidth edge frequency and the nominal -3 dB point of the measuring filter closest to the carrier frequency
Δf_{max}	The largest value of Δf used for defining the requirement
F_C	Carrier centre frequency
F_{filter}	Filter centre frequency
f_{offset}	Separation between the Base Station RF bandwidth edge frequency and the centre of the measuring filter
$f_{offset_{max}}$	The maximum value of f_{offset} used for defining the requirement
$F_{block,high}$	Upper sub-block edge, where $F_{block,high} = F_{C,block,high} + F_{offset, RAT}$
$F_{block,low}$	Lower sub-block edge, where $F_{block,low} = F_{C,block,low} - F_{offset, RAT}$
$F_{BW\ RF,high}$	Upper Base Station RF bandwidth edge, where $F_{BW\ RF,high} = F_{C,high} + F_{offset, RAT}$
$F_{BW\ RF,low}$	Lower Base Station RF bandwidth edge, where $F_{BW\ RF,low} = F_{C,low} - F_{offset, RAT}$
$F_{C,block, high}$	Center frequency of the highest transmitted/received carrier in a sub-block
$F_{C,block, low}$	Center frequency of the lowest transmitted/received carrier in a sub-block
$F_{C,high}$	Center frequency of the highest transmitted/received carrier
$F_{C,low}$	Center frequency of the lowest transmitted/received carrier
$F_{offset, RAT}$	Frequency offset from the centre frequency of the <i>highest</i> transmitted/received carrier to the <i>upper</i> Base Station RF bandwidth edge, sub-block edge or inter-RF bandwidth edge, or from the centre frequency of the <i>lowest</i> transmitted/received carrier to the <i>lower</i> Base Station RF bandwidth edge, sub-block edge or inter-RF bandwidth edge for a specific RAT
$F_{UL,low}$	The lowest frequency of the uplink operating band
$F_{UL,high}$	The highest frequency of the uplink operating band
M_{RFBW}	Maximum Base Station RF bandwidth located in the middle of the supported frequency range in the operating band
$P_{EM,B32,ind}$	Declared emission level (a) for Band 3, ind = a, b, c, d, e
$P_{EM,N}$	Declared emission level for channel N
$P_{GSMcarrier}$	Power level of the GSM/EDGE carrier adjacent to the RF bandwidth edge
P_{max}	Maximum total output power
$P_{max,c}$	Maximum carrier output power
$P_{REFSENS}$	Reference Sensitivity power level
T_{RFBW}	Maximum Base Station RF bandwidth located at the top of the supported frequency range in the operating band
W_{gap}	Sub-block gap size or Inter RF bandwidth gap size

3.3 Abbreviations

For the purposes of the present document, the following abbreviations apply:

4C-HSDPA	Four-Carrier HSDPA
ACLR	Adjacent Channel Leakage Ratio
AM	Amplitude Modulation
ARFCN	Absolute Radio Frequency Channel Number
ATT	Attenuator
BC	Band Category
BER	Bit Error Ratio
BS	Base Station

BTS	Base Transceiver Station
BW	Bandwidth
CA	Carrier Aggregation
CACLR	Cumulative Adjacent Channel Leakage Ratio
CEPT	European Conference of Postal and Telecommunications Administrations
CS	Capability Set
CW	Continuous Wave
DB-DC-HSDPA	Dual Band Dual Cell HSDPA
DC	Direct Current
DTT	Digital Terrestrial Television
DwPTS	Downlink part of the special subframe (for E-UTRA TDD operation)
EC	European Communities
ECC	Electronic Communications Committee
EDGE	Enhanced Data rates for GSM Evolution
EFTA	European Free Trade Association
EU	European Union
EUT	Equipment Under Test
E-UTRA	Evolved Universal Terrestrial Radio Access
FDD	Frequency Division Duplex
FRC	Fixed Reference Channel

NOTE: The fixed reference channels for E-UTRA are detailed in annex A of ETSI TS 136 141 [11].

GMSK	Gaussian Minimum Shift Keying
GSM	Global System for Mobile communications
IMT	International Mobile Telecommunications
ITU-R	International Telecommunication Union Radiocommunication sector
LA	Local Area
MB-MSR	Multi-Band Multi-Standard Radio
MBT	Multi-Band Testing
MC-BTS	Multi-Carrier Base Transceiver Station
MR	Medium Range
MS	Mobile Station
MSR	Multi-Standard Radio
Pcell	Primary cell
RAT	Radio Access Technology
RB	Resource Block (for E-UTRA)
RF	Radio Frequency
RMS	Root Mean Square (value)
RRC	Root-Raised Cosine
RX	Receiver
SBT	Single Band Testing
TC	Test Configuration
TDD	Time Division Duplex
TX	Transmitter
UARFCN	UTRA Absolute Radio Frequency Channel Number
UE	User Equipment
UEM	operating band Unwanted Emissions Mask
UTRA	Universal Terrestrial Radio Access
WA	Wide Area

4 Technical requirements specifications

4.1 Environmental profile

The technical requirements of the present document apply under the environmental profile for operation of the equipment, which shall be declared by the manufacturer. The equipment shall comply with all the technical requirements of the present document at all times when operating within the boundary limits of the declared operational environmental profile.

For guidance on how a manufacturer can declare the environmental profile, see annex C.

4.2 Conformance requirements

4.2.1 Introduction

The requirements in the present document are based on the assumption that the operating band (see table 1-1) is shared between systems of the IMT family (for Band 3 and 8 also GSM) or systems having compatible characteristics.

To meet the essential requirement under article 3.2 of Directive 2014/53/EU [i.1] for IMT Base Stations (BS), a set of essential parameters in addition to those in ETSI EN 301 908-1 [i.4] have been identified. Table 4.2.1-1 provides a cross reference between these essential parameters and the corresponding technical requirements for equipment within the scope of the present document.

Table 4.2.1-1: Cross references

Essential parameter	Corresponding technical requirements	Corresponding test suite
Transmitter spectrum mask	4.2.2 Operating band unwanted emissions	5.3.1
Transmitter unwanted emissions in the out-of-band domain	4.2.3 Adjacent Channel Leakage power Ratio (ACLR)	5.3.2
Transmitter unwanted emissions in the spurious domain	4.2.4 Transmitter spurious emissions	5.3.3
Transmitter power accuracy	4.2.5 Base station maximum output power	5.3.4
Transmitter intermodulation attenuation	4.2.6 Transmit intermodulation	5.3.5
Receiver unwanted emissions in the spurious domain	4.2.7 Receiver spurious emissions	5.3.6
Receiver blocking	4.2.8 In-band blocking	5.3.7
Receiver desensitization	4.2.9 Out-of-band blocking	5.3.8
Receiver radio-frequency intermodulation	4.2.10 Receiver intermodulation characteristics	5.3.9
Receiver adjacent signal selectivity	4.2.11 Narrowband blocking	5.3.10
Receiver sensitivity	4.2.12 Reference sensitivity level	5.3.11

NOTE: There are EC, EU and ECC Decisions for the harmonisation of certain frequency bands for terrestrial systems capable of providing electronic communications services, including technical conditions and parameters related to spectrum usage of the bands. These are related to the deployment and installation of the equipment, but are not related to the conformity of the equipment with the present document.

The manufacturer shall declare the following:

- The operating band(s) supported by the Base Station according to table 1-1.
- The supported capability set(s) according to clause 4.7.1 of ETSI TS 137 141 [1].
- The supported RF configurations according to clause 4.7.2 of ETSI TS 137 141 [1].
- The intended class of the BS under test.

The technical requirements in the present document apply for the declared Base Station class and the declared operating band(s) as outlined for each requirement. For a Base Station supporting more than one operating band, conformance testing for each technical requirement in clause 5 shall be performed for each operating band.

For GSM/EDGE operation of a BS, the requirements according to the applicable multicarrier BTS class apply. The Wide Area BS, Medium Range BS and Local Area BS in the present document correspond to the Wide Area multicarrier BTS, Medium Range multicarrier BTS and Local Area multicarrier BTS respectively in the GSM/EDGE specifications [14].

All technical requirements shall apply with a frequency offset from the lowest and highest carrier frequencies transmitted or received in the specified operating band to the Base Station RF bandwidth edges ($F_{\text{offset, RAT}}$) that is specific for each RAT in each Band Category as defined in clause 4.4 of ETSI TS 137 141 [1].

The technical requirements also apply to the BS configurations described in annex B.

For a BS declared to support Band 20 and to operate in geographic areas within the CEPT in which frequencies are allocated to broadcasting (DTT) service, the manufacturer shall additionally declare the following quantities associated with the applicable test conditions of table 4.2.2.2.4-1 and information in annex G of ETSI TS 136 104 [4]:

- $P_{EM,N}$ Declared emission level for channel N.
- $P_{10\text{ MHz}}$ Maximum output Power in 10 MHz.

For a BS declared to support Band 32, the manufacturer shall additionally declare the following quantities associated with the applicable test conditions of tables 4.2.2.2.6-1 and 4.2.2.2.6-2 of the present document, and information in annex H of ETSI TS 136 104 [4]:

- $P_{EM,B32,a}$, $P_{EM,B32,b}$, $P_{EM,B32,c}$, $P_{EM,B32,d}$ and $P_{EM,B32,e}$ Declared emission levels in band 32.

E-UTRA is designed to operate for the carrier aggregation bands defined in tables 4.2.1-2 to 4.2.1-5.

Table 4.2.1-2: Intra-band contiguous carrier aggregation bands

CA Band	E-UTRA or MSR operating band
CA_1	1
CA_3	3
CA_7	7
CA_38	38
CA_40	40
CA_42	42

Table 4.2.1-3: Inter-band carrier aggregation bands

CA Band	E-UTRA operating bands
CA_1-3	1
	3
CA_1-7	1
	7
CA_1-8	1
	8
CA_1-20	1
	20
CA_1-28	1
	28
CA_1-42	1
	42
CA_3-7	3
	7
CA_3-8	3
	8
CA_3-20	3
	20
CA_3-28	3
	28

CA Band	E-UTRA operating bands
CA_3-42	3
	42
CA_7-8	7
	8
CA_7-20	7
	20
CA_7-28	7
	28
CA_8-20	8
	20
CA_8-40	8
	40
CA_20-32	20
	32

Table 4.2.1-4: Inter-band carrier aggregation bands (three bands)

CA Band	E-UTRA operating bands
CA_1-3-8	1
	3
	8
CA_1-3-20	1
	3
	20
CA_1-7-20	1
	7
	20
CA_3-7-20	3
	7
	20
CA_7-8-20	7
	8
	20

Table 4.2.1-5: Intra-band non-contiguous carrier aggregation bands (with two sub-blocks)

CA Band	E-UTRA operating bands
CA_1-1	1
CA_7-7	7
CA_42-42	42

For BS capable of multi-band operation, the technical requirements in the present clause shall apply for each supported operating band unless otherwise stated. For some requirements it is explicitly stated that specific additions or exclusions to the requirement shall apply for BS capable of multi-band operation. In the case of multiband operation of a BS, single-RAT operation and the corresponding applicability of the requirements for each operating band is determined based on the RAT configuration within only that operating band, unless otherwise stated.

For BS capable of multi-band operation, various structures in terms of combinations of different transmitter and receiver implementations (multi-band or single band) with mapping of transceivers to one or more antenna port(s) in different ways are possible. In the case where multiple bands are mapped on separate antenna connectors, the following shall apply:

- Single-band transmitter spurious emissions, operating band unwanted emissions, ACLR, transmitter intermodulation and receiver spurious emissions requirements shall apply to each antenna connector.
- If the BS is configured for single-band operation, single-band requirements shall apply to the antenna connector configured for single-band operation and no exclusions or provisions for multi-band capable BS are applicable. Single-band requirements are tested separately at the antenna connector configured for single-band operation, with all other antenna connectors terminated.

For a BS capable of multi-band operation supporting BC3 bands for TDD, the RF requirements in the present specification assume synchronized operation, where no simultaneous uplink and downlink occur between the bands.

4.2.2 Operating band unwanted emissions

4.2.2.1 Definition

Unwanted emissions consist of out-of-band emissions and spurious emissions (Recommendation ITU-R SM.329-12 [i.5]). Out of band emissions are emissions immediately outside the channel bandwidth resulting from the modulation process and non-linearity in the transmitter but excluding spurious emissions. Spurious emissions are emissions which are caused by unwanted transmitter effects such as harmonics emission, parasitic emission, intermodulation products and frequency conversion products, but exclude out-of-band emissions. Operating band unwanted emissions cover both out-of-band and spurious domain frequencies.

The Operating band unwanted emission limits are defined from 10 MHz below the lowest frequency of each supported downlink operating band to the lower Base Station RF bandwidth edge located at $F_{\text{BW RF,low}}$ and from the upper Base Station RF bandwidth edge located at $F_{\text{BW RF,high}}$ up to 10 MHz above the highest frequency of each supported downlink operating band. In addition, for a BS operating in non-contiguous spectrum, it shall apply inside any sub-block gap. In addition, for a BS operating in multiple bands, it applies inside any Inter RF bandwidth gap.

The requirements shall apply whatever the type of transmitter considered and for all transmission modes foreseen by the manufacturer's specification, except for any operating band with GSM/EDGE single RAT operation. The requirements in ETSI TS 145 005 [5] as defined in clause 4.2.2.2.3 shall apply to an MSR Base Station for any operating band with GSM/EDGE single RAT operation in Band Category 2.

For BS capable of multi-band operation where multiple bands are mapped on separate antenna connectors, the single-band requirements shall apply and the cumulative evaluation of the emission limit in the inter-RF bandwidth gap are not applicable.

4.2.2.2 Limits

4.2.2.2.1 Limits for Band Categories 1 and 3

For a Wide Area BS operating in Band Category 1 or Band Category 3 the requirement shall apply outside the Base Station RF bandwidth edges. In addition, for a Wide Area BS operating in non-contiguous spectrum, it shall apply inside any sub-block gap. In addition, for a Wide Area BS operating in multiple bands, it applies inside any Inter RF bandwidth gap.

For a Medium Range BS operating in Band Category 1 the requirement shall apply outside the Base Station RF bandwidth edges. In addition, for a Medium Range BS operating in non-contiguous spectrum, it shall apply inside any sub-block gap. In addition, for a Medium Range BS operating in multiple bands, it applies inside any Inter RF bandwidth gap.

For a Local Area BS operating in Band Category 1 the requirement shall apply outside the Base Station RF bandwidth edges. In addition, for a Local Area BS operating in non-contiguous spectrum, it shall apply inside any sub-block gap. In addition, for a Local Area BS operating in multiple bands, it applies inside any Inter RF bandwidth gap.

Outside the Base Station RF bandwidth edges, emissions shall not exceed the maximum levels specified in tables 4.2.2.2.1-1 to 4.2.2.2.1-8, where:

- Δf is the separation between the Base Station RF bandwidth edge frequency and the nominal -3 dB point of the measuring filter closest to the carrier frequency.
- f_{offset} is the separation between the Base Station RF bandwidth edge frequency and the centre of the measuring filter.
- $f_{\text{offset}_{\text{max}}}$ is the offset to the frequency 10 MHz outside the downlink operating band.
- Δf_{max} is equal to $f_{\text{offset}_{\text{max}}}$ minus half of the bandwidth of the measuring filter.

For a BS operating in multiple bands, inside any inter-RF bandwidth gaps with $W_{\text{gap}} < 20$ MHz, emissions shall not exceed the cumulative sum of the test requirements specified at the Base Station RF bandwidth edges on each side of the inter-RF bandwidth gap. The test requirement for Base Station RF bandwidth edge is specified in tables 4.2.2.2.1-1 to 4.2.2.2.1-8, where in this case:

- Δf is the separation between the Base Station RF bandwidth edge frequency and the nominal -3 dB point of the measuring filter closest to the carrier frequency.
- f_{offset} is the separation between the Base Station RF bandwidth edge frequency and the centre of the measuring filter.
- $f_{\text{offset}_{\text{max}}}$ is equal to the Inter RF bandwidth gap minus half of the bandwidth of the measuring filter.
- Δf_{max} is equal to $f_{\text{offset}_{\text{max}}}$ minus half of the bandwidth of the measuring filter.

For BS capable of multi-band operation where multiple bands are mapped on the same antenna connector, the operating band unwanted emission limits apply also in a supported operating band without any carriers transmitted, in the case where there are carriers transmitted in another operating band. In this case where there is no carrier transmitted in an operating band, no cumulative limits are applied in the inter-band gap between a supported downlink band with carrier(s) transmitted and a downlink band without any carrier transmitted; and:

- In case the inter-band gap between a supported downlink band with carrier(s) transmitted and a supported downlink band without any carrier transmitted is less than 20 MHz, $f_{\text{offset}_{\text{max}}}$ shall be the offset to the frequency 10 MHz outside the outermost edges of the two supported downlink operating bands and the operating band unwanted emission limit of the band where there are carriers transmitted, as defined in the tables of the present clause, shall apply across both supported downlink bands.
- In other cases, the operating band unwanted emission limit of the band where there are carriers transmitted, as defined in the tables of the present clause for the largest frequency offset (Δf_{max}), shall apply from 10 MHz below the lowest frequency, up to 10 MHz above the highest frequency of the supported downlink operating band without any carrier transmitted.

Inside any sub-block gap for a BS operating in non-contiguous spectrum, emissions shall not exceed the cumulative sum of the test requirements specified for the adjacent sub-blocks on each side of the sub-block gap. The test requirement for each sub-block is specified in tables 4.2.2.2.1-1 to 4.2.2.2.1-8, where in this case:

- Δf is the separation between the sub-block edge frequency and the nominal -3 dB point of the measuring filter closest to the sub-block edge frequency.
- f_{offset} is the separation between the sub-block edge frequency and the centre of the measuring filter.
- $f_{\text{offset}_{\text{max}}}$ is equal to the sub-block gap bandwidth minus half of the bandwidth of the measuring filter.
- Δf_{max} is equal to $f_{\text{offset}_{\text{max}}}$ minus half of the bandwidth of the measuring filter.

**Table 4.2.2.2.1-1: Wide Area BS operating band unwanted emission mask (UEM)
for BC1 and BC3 for bands ≤ 3 GHz**

Frequency offset of measurement filter -3 dB point, Δf	Frequency offset of measurement filter centre frequency, f_{offset}	Test requirement (see notes 3 and 4)	Measurement bandwidth
$0 \text{ MHz} \leq \Delta f < 0,2 \text{ MHz}$	$0,015 \text{ MHz} \leq f_{\text{offset}} < 0,215 \text{ MHz}$	-12,5 dBm	30 kHz
$0,2 \text{ MHz} \leq \Delta f < 1 \text{ MHz}$	$0,215 \text{ MHz} \leq f_{\text{offset}} < 1,015 \text{ MHz}$	$-12,5 \text{ dBm} - 15 \cdot \left(\frac{f_{\text{offset}}}{\text{MHz}} - 0,215 \right) \text{ dB}$	30 kHz
(see note 1)	$1,015 \text{ MHz} \leq f_{\text{offset}} < 1,5 \text{ MHz}$	-24,5 dBm	30 kHz
$1 \text{ MHz} \leq \Delta f \leq \min(\Delta f_{\text{max}}, 10 \text{ MHz})$	$1,5 \text{ MHz} \leq f_{\text{offset}} < \min(f_{\text{offset}_{\text{max}}}, 10,5 \text{ MHz})$	-11,5 dBm	1 MHz
$10 \text{ MHz} \leq \Delta f \leq \Delta f_{\text{max}}$	$10,5 \text{ MHz} \leq f_{\text{offset}} < f_{\text{offset}_{\text{max}}}$	-15 dBm (see note 2)	1 MHz
NOTE 1: This frequency range ensures that the range of values of f_{offset} is continuous.			
NOTE 2: The requirement is not applicable when $\Delta f_{\text{max}} < 10 \text{ MHz}$.			
NOTE 3: For MSR BS supporting non-contiguous spectrum operation within any operating band the test requirement within sub-block gaps is calculated as a cumulative sum of contributions from adjacent sub-blocks on each side of the sub-block gap, where the contribution from the far-end sub-block shall be scaled according to the measurement bandwidth of the near-end sub-block. Exception is $\Delta f \geq 10 \text{ MHz}$ from both adjacent sub-blocks or Base Station RF Bandwidth on each side of the sub-block gap, where the test requirement within sub-block gaps shall be -15 dBm/MHz.			
NOTE 4: For MSR BS supporting multi-band operation with Inter RF bandwidth gap < 20 MHz the test requirement within the Inter RF bandwidth gaps is calculated as a cumulative sum of contributions from adjacent sub-blocks on each side of the Inter RF bandwidth gap, where the contribution from the far-end sub-block or Base Station RF Bandwidth shall be scaled according to the measurement bandwidth of the near-end sub-block or Base Station RF Bandwidth.			

**Table 4.2.2.2.1-2: Wide Area BS operating band unwanted emission mask (UEM)
for BC1 and BC3 for bands > 3 GHz**

Frequency offset of measurement filter -3 dB point, Δf	Frequency offset of measurement filter centre frequency, f_{offset}	Test requirement (see notes 3 and 4)	Measurement bandwidth
$0 \text{ MHz} \leq \Delta f < 0,2 \text{ MHz}$	$0,015 \text{ MHz} \leq f_{\text{offset}} < 0,215 \text{ MHz}$	-12,2 dBm	30 kHz
$0,2 \text{ MHz} \leq \Delta f < 1 \text{ MHz}$	$0,215 \text{ MHz} \leq f_{\text{offset}} < 1,015 \text{ MHz}$	$-12,2 \text{ dBm} - 15 \cdot \left(\frac{f_{\text{offset}}}{\text{MHz}} - 0,215 \right) \text{ dB}$	30 kHz
(see note 1)	$1,015 \text{ MHz} \leq f_{\text{offset}} < 1,5 \text{ MHz}$	-24,2 dBm	30 kHz
$1 \text{ MHz} \leq \Delta f \leq \min(\Delta f_{\text{max}}, 10 \text{ MHz})$	$1,5 \text{ MHz} \leq f_{\text{offset}} < \min(f_{\text{offset}_{\text{max}}}, 10,5 \text{ MHz})$	-11,2 dBm	1 MHz
$10 \text{ MHz} \leq \Delta f \leq \Delta f_{\text{max}}$	$10,5 \text{ MHz} \leq f_{\text{offset}} < f_{\text{offset}_{\text{max}}}$	-15 dBm (see note 2)	1 MHz
NOTE 1: This frequency range ensures that the range of values of f_{offset} is continuous.			
NOTE 2: The requirement is not applicable when $\Delta f_{\text{max}} < 10 \text{ MHz}$.			
NOTE 3: For MSR BS supporting non-contiguous spectrum operation within any operating band the test requirement within sub-block gaps is calculated as a cumulative sum of contributions from adjacent sub-blocks on each side of the sub-block gap, where the contribution from the far-end sub-block shall be scaled according to the measurement bandwidth of the near-end sub-block. Exception is $\Delta f \geq 10 \text{ MHz}$ from both adjacent sub-blocks on each side of the sub-block gap, where the test requirement within sub-block gaps shall be -15 dBm/MHz.			
NOTE 4: For MSR BS supporting multi-band operation with Inter RF bandwidth gap < 20 MHz the test requirement within the Inter RF bandwidth gaps is calculated as a cumulative sum of contributions from adjacent sub-blocks or Base Station RF Bandwidth on each side of the Inter RF bandwidth gap, where the contribution from the far-end sub-block or Base Station RF Bandwidth shall be scaled according to the measurement bandwidth of the near-end sub-block or Base Station RF Bandwidth.			

Table 4.2.2.2.1-3: Medium Range BS operating band unwanted emission mask (UEM) for BC1 for bands ≤ 3 GHz, BS maximum output power 31 < P_{max,c} ≤ 38 dBm

Frequency offset of measurement filter -3 dB point, Δf	Frequency offset of measurement filter centre frequency, f _{offset}	Test requirement (see notes 3 and 4)	Measurement bandwidth
0 MHz ≤ Δf < 0,6 MHz	0,015 MHz ≤ f _{offset} < 0,615 MHz	$P_{\max,c} - 56,5 \text{ dB} - \frac{7}{5} \left(\frac{f_{\text{offset}}}{\text{MHz}} - 0,015 \right) \text{ dB}$	30 kHz
0,6 MHz ≤ Δf < 1 MHz	0,615 MHz ≤ f _{offset} < 1,015 MHz	$P_{\max,c} - 51,5 \text{ dB} - 15 \left(\frac{f_{\text{offset}}}{\text{MHz}} - 0,215 \right) \text{ dB}$	30 kHz
(see note 1)	1,015 MHz ≤ f _{offset} < 1,5 MHz	P _{max,c} - 63,5 dB	30 kHz
1 MHz ≤ Δf ≤ 2,6 MHz	1,5 MHz ≤ f _{offset} < 3,1 MHz	P _{max,c} - 50,5 dB	1 MHz
2,6 MHz ≤ Δf ≤ 5 MHz	3,1 MHz ≤ f _{offset} < 5,5 MHz	min(P _{max,c} - 50,5 dB, -13,5 dBm)	1 MHz
5 MHz ≤ Δf ≤ min(Δf _{max} , 10 MHz)	5,5 MHz ≤ f _{offset} < min(f _{offset_max} , 10,5 MHz)	P _{max,c} - 54,5 dB	1 MHz
10 MHz ≤ Δf ≤ Δf _{max}	10,5 MHz ≤ f _{offset} < f _{offset_max}	P _{max,c} - 56 dB (see note 2)	1 MHz

NOTE 1: This frequency range ensures that the range of values of f_{offset} is continuous.
NOTE 2: The requirement is not applicable when Δf_{max} < 10 MHz.
NOTE 3: For MSR BS supporting non-contiguous spectrum operation within any operating band the test requirement within sub-block gaps is calculated as a cumulative sum of contributions from adjacent sub-blocks on each side of the sub-block gap, where the contribution from the far-end sub-block shall be scaled according to the measurement bandwidth of the near-end sub-block. Exception is Δf ≥ 10 MHz from both adjacent sub-blocks on each side of the sub-block gap, where the test requirement within sub-block gaps shall be (P_{max,c} - 56 dB)/MHz.
NOTE 4: For MSR BS supporting multi-band operation with Inter RF bandwidth gap < 20 MHz the test requirement within the Inter RF bandwidth gaps is calculated as a cumulative sum of contributions from adjacent sub-blocks or Base Station RF Bandwidth on each side of the Inter RF bandwidth gap, where the contribution from the far-end sub-block or Base Station RF Bandwidth shall be scaled according to the measurement bandwidth of the near-end sub-block or Base Station RF Bandwidth.

Table 4.2.2.2.1-4: Medium Range BS operating band unwanted emission mask (UEM) for BC1 for bands > 3 GHz, BS maximum output power 31 < P_{max,c} ≤ 38 dBm

Frequency offset of measurement filter -3 dB point, Δf	Frequency offset of measurement filter centre frequency, f _{offset}	Test requirement (see notes 3 and 4)	Measurement bandwidth
0 MHz ≤ Δf < 0,6 MHz	0,015 MHz ≤ f _{offset} < 0,615 MHz	$P_{\max,c} - 56,2 \text{ dB} - \frac{7}{5} \left(\frac{f_{\text{offset}}}{\text{MHz}} - 0,015 \right) \text{ dB}$	30 kHz
0,6 MHz ≤ Δf < 1 MHz	0,615 MHz ≤ f _{offset} < 1,015 MHz	$P_{\max,c} - 51,2 \text{ dB} - 15 \left(\frac{f_{\text{offset}}}{\text{MHz}} - 0,215 \right) \text{ dB}$	30 kHz
(see note 1)	1,015 MHz ≤ f _{offset} < 1,5 MHz	P _{max,c} - 63,2 dB	30 kHz
1 MHz ≤ Δf ≤ 2,6 MHz	1,5 MHz ≤ f _{offset} < 3,1 MHz	P _{max,c} - 50,2 dB	1 MHz
2,6 MHz ≤ Δf ≤ 5 MHz	3,1 MHz ≤ f _{offset} < 5,5 MHz	min(P _{max,c} - 50,2 dB, -13,2 dBm)	1 MHz
5 MHz ≤ Δf ≤ min(Δf _{max} , 10 MHz)	5,5 MHz ≤ f _{offset} < min(f _{offset_max} , 10,5 MHz)	P _{max,c} - 54,2 dB	1 MHz
10 MHz ≤ Δf ≤ Δf _{max}	10,5 MHz ≤ f _{offset} < f _{offset_max}	P _{max,c} - 56 dB (see note 2)	1 MHz

NOTE 1: This frequency range ensures that the range of values of f_{offset} is continuous.
NOTE 2: The requirement is not applicable when Δf_{max} < 10 MHz.
NOTE 3: For MSR BS supporting non-contiguous spectrum operation within any operating band the test requirement within sub-block gaps is calculated as a cumulative sum of contributions from adjacent sub-blocks on each side of the sub-block gap, where the contribution from the far-end sub-block shall be scaled according to the measurement bandwidth of the near-end sub-block. Exception is Δf ≥ 10 MHz from both adjacent sub-blocks on each side of the sub-block gap, where the test requirement within sub-block gaps shall be (P_{max,c} - 56 dB)/MHz.
NOTE 4: For MSR BS supporting multi-band operation with Inter RF bandwidth gap < 20 MHz the test requirement within the Inter RF bandwidth gaps is calculated as a cumulative sum of contributions from adjacent sub-blocks or Base Station RF Bandwidth on each side of the Inter RF bandwidth gap, where the contribution from the far-end sub-block or Base Station RF Bandwidth shall be scaled according to the measurement bandwidth of the near-end sub-block or Base Station RF Bandwidth.

Table 4.2.2.1-5: Medium Range BS operating band unwanted emission mask (UEM) for BC1 for bands ≤ 3 GHz, BS maximum output power $P_{\max,c} \leq 31$ dBm

Frequency offset of measurement filter -3 dB point, Δf	Frequency offset of measurement filter centre frequency, f_{offset}	Test requirement (see notes 3 and 4)	Measurement bandwidth
$0 \text{ MHz} \leq \Delta f < 0,6 \text{ MHz}$	$0,015 \text{ MHz} \leq f_{\text{offset}} < 0,615 \text{ MHz}$	$-25,5 \text{ dBm} - \frac{7}{5} \cdot \left(\frac{f_{\text{offset}}}{\text{MHz}} - 0,015 \right) \text{ dB}$	30 kHz
$0,6 \text{ MHz} \leq \Delta f < 1 \text{ MHz}$	$0,615 \text{ MHz} \leq f_{\text{offset}} < 1,015 \text{ MHz}$	$-20,5 \text{ dBm} - 15 \cdot \left(\frac{f_{\text{offset}}}{\text{MHz}} - 0,215 \right) \text{ dB}$	30 kHz
(see note 1)	$1,015 \text{ MHz} \leq f_{\text{offset}} < 1,5 \text{ MHz}$	-32,5 dBm	30 kHz
$1 \text{ MHz} \leq \Delta f \leq 5 \text{ MHz}$	$1,5 \text{ MHz} \leq f_{\text{offset}} < 5,5 \text{ MHz}$	-19,5 dBm	1 MHz
$5 \text{ MHz} \leq \Delta f \leq \min(\Delta f_{\max}, 10 \text{ MHz})$	$5,5 \text{ MHz} \leq f_{\text{offset}} < \min(f_{\text{offset}_{\max}}, 10,5 \text{ MHz})$	-23,5 dBm	1 MHz
$10 \text{ MHz} \leq \Delta f \leq \Delta f_{\max}$	$10,5 \text{ MHz} \leq f_{\text{offset}} < f_{\text{offset}_{\max}}$	-25 dBm (see note 2)	1 MHz

NOTE 1: This frequency range ensures that the range of values of f_{offset} is continuous.
NOTE 2: The requirement is not applicable when $\Delta f_{\max} < 10$ MHz.
NOTE 3: For MSR BS supporting non-contiguous spectrum operation within any operating band the test requirement within sub-block gaps is calculated as a cumulative sum of contributions from adjacent sub-blocks on each side of the sub-block gap, where the contribution from the far-end sub-block shall be scaled according to the measurement bandwidth of the near-end sub-block. Exception is $\Delta f \geq 10$ MHz from both adjacent sub-blocks on each side of the sub-block gap, where the test requirement within sub-block gaps shall be -25 dBm/MHz.
NOTE 4: For MSR BS supporting multi-band operation with Inter RF bandwidth gap < 20 MHz the test requirement within the Inter RF bandwidth gaps is calculated as a cumulative sum of contributions from adjacent sub-blocks or Base Station RF Bandwidth on each side of the Inter RF bandwidth gap, where the contribution from the far-end sub-block or Base Station RF Bandwidth shall be scaled according to the measurement bandwidth of the near-end sub-block or Base Station RF Bandwidth.

Table 4.2.2.1-6: Medium Range BS operating band unwanted emission mask (UEM) for BC1 for bands > 3 GHz, BS maximum output power $P_{\max,c} \leq 31$ dBm

Frequency offset of measurement filter -3 dB point, Δf	Frequency offset of measurement filter centre frequency, f_{offset}	Test requirement (see notes 3 and 4)	Measurement bandwidth
$0 \text{ MHz} \leq \Delta f < 0,6 \text{ MHz}$	$0,015 \text{ MHz} \leq f_{\text{offset}} < 0,615 \text{ MHz}$	$-25,2 \text{ dBm} - \frac{7}{5} \cdot \left(\frac{f_{\text{offset}}}{\text{MHz}} - 0,015 \right) \text{ dB}$	30 kHz
$0,6 \text{ MHz} \leq \Delta f < 1 \text{ MHz}$	$0,615 \text{ MHz} \leq f_{\text{offset}} < 1,015 \text{ MHz}$	$-20,2 \text{ dBm} - 15 \cdot \left(\frac{f_{\text{offset}}}{\text{MHz}} - 0,215 \right) \text{ dB}$	30 kHz
(see note 1)	$1,015 \text{ MHz} \leq f_{\text{offset}} < 1,5 \text{ MHz}$	-32,2 dBm	30 kHz
$1 \text{ MHz} \leq \Delta f \leq 5 \text{ MHz}$	$1,5 \text{ MHz} \leq f_{\text{offset}} < 5,5 \text{ MHz}$	-19,2 dBm	1 MHz
$5 \text{ MHz} \leq \Delta f \leq \min(\Delta f_{\max}, 10 \text{ MHz})$	$5,5 \text{ MHz} \leq f_{\text{offset}} < \min(f_{\text{offset}_{\max}}, 10,5 \text{ MHz})$	-23,2 dBm	1 MHz
$10 \text{ MHz} \leq \Delta f \leq \Delta f_{\max}$	$10,5 \text{ MHz} \leq f_{\text{offset}} < f_{\text{offset}_{\max}}$	-25 dBm (see note 2)	1 MHz

NOTE 1: This frequency range ensures that the range of values of f_{offset} is continuous.
NOTE 2: The requirement is not applicable when $\Delta f_{\max} < 10$ MHz.
NOTE 3: For MSR BS supporting non-contiguous spectrum operation within any operating band the test requirement within sub-block gaps is calculated as a cumulative sum of contributions from adjacent sub-blocks on each side of the sub-block gap, where the contribution from the far-end sub-block shall be scaled according to the measurement bandwidth of the near-end sub-block. Exception is $\Delta f \geq 10$ MHz from both adjacent sub-blocks on each side of the sub-block gap, where the test requirement within sub-block gaps shall be -25 dBm/MHz.
NOTE 4: For MSR BS supporting multi-band operation with Inter RF bandwidth gap < 20 MHz the test requirement within the Inter RF bandwidth gaps is calculated as a cumulative sum of contributions from adjacent sub-blocks or Base Station RF Bandwidth on each side of the Inter RF bandwidth gap, where the contribution from the far-end sub-block or Base Station RF Bandwidth shall be scaled according to the measurement bandwidth of the near-end sub-block or Base Station RF Bandwidth.

**Table 4.2.2.2.1-7: Local Area operating band unwanted emission mask (UEM)
for BC1 for bands ≤ 3 GHz**

Frequency offset of measurement filter -3 dB point, Δf	Frequency offset of measurement filter centre frequency, f_{offset}	Test requirement (see notes 2 and 3)	Measurement bandwidth
$0 \text{ MHz} \leq \Delta f < 5 \text{ MHz}$	$0,05 \text{ MHz} \leq f_{\text{offset}} < 5,05 \text{ MHz}$	$-28,5 \text{ dBm} - \frac{7}{5} \left(\frac{f_{\text{offset}}}{\text{MHz}} - 0,05 \right) \text{ dB}$	100 kHz
$5 \text{ MHz} \leq \Delta f < \min(10 \text{ MHz}, \Delta f_{\text{max}})$	$5,05 \text{ MHz} \leq f_{\text{offset}} < \min(10,05 \text{ MHz}, f_{\text{offset}_{\text{max}}})$	-35,5 dBm	100 kHz
$10 \text{ MHz} \leq \Delta f \leq \Delta f_{\text{max}}$	$10,05 \text{ MHz} \leq f_{\text{offset}} < f_{\text{offset}_{\text{max}}}$	-37 dBm (see note 1)	100 kHz

NOTE 1: The requirement is not applicable when $\Delta f_{\text{max}} < 10 \text{ MHz}$.

NOTE 2: For MSR BS supporting non-contiguous spectrum operation within any operating band the test requirement within sub-block gaps is calculated as a cumulative sum of contributions from adjacent sub-blocks on each side of the sub-block gap. Exception is $\Delta f \geq 10 \text{ MHz}$ from both adjacent sub-blocks on each side of the sub-block gap, where the test requirement within sub-block gaps shall be -37 dBm/100 kHz.

NOTE 3: For MSR BS supporting multi-band operation with Inter RF bandwidth gap < 20 MHz the test requirement within the Inter RF bandwidth gaps is calculated as a cumulative sum of contributions from adjacent sub-blocks or Base Station RF Bandwidth on each side of the Inter RF bandwidth gap.

**Table 4.2.2.2.1-8: Local Area operating band unwanted emission mask (UEM)
for BC1 for bands > 3 GHz**

Frequency offset of measurement filter -3 dB point, Δf	Frequency offset of measurement filter centre frequency, f_{offset}	Test requirement (see notes 2 and 3)	Measurement bandwidth
$0 \text{ MHz} \leq \Delta f < 5 \text{ MHz}$	$0,05 \text{ MHz} \leq f_{\text{offset}} < 5,05 \text{ MHz}$	$-28,2 \text{ dBm} - \frac{7}{5} \left(\frac{f_{\text{offset}}}{\text{MHz}} - 0,05 \right) \text{ dB}$	100 kHz
$5 \text{ MHz} \leq \Delta f < \min(10 \text{ MHz}, \Delta f_{\text{max}})$	$5,05 \text{ MHz} \leq f_{\text{offset}} < \min(10,05 \text{ MHz}, f_{\text{offset}_{\text{max}}})$	-35,2 dBm	100 kHz
$10 \text{ MHz} \leq \Delta f \leq \Delta f_{\text{max}}$	$10,05 \text{ MHz} \leq f_{\text{offset}} < f_{\text{offset}_{\text{max}}}$	-37 dBm (see note 1)	100 kHz

NOTE 1: The requirement is not applicable when $\Delta f_{\text{max}} < 10 \text{ MHz}$.

NOTE 2: For MSR BS supporting non-contiguous spectrum operation within any operating band the test requirement within sub-block gaps is calculated as a cumulative sum of contributions from adjacent sub-blocks on each side of the sub-block gap. Exception is $\Delta f \geq 10 \text{ MHz}$ from both adjacent sub-blocks on each side of the sub-block gap, where the test requirement within sub-block gaps shall be -37 dBm/100 kHz.

NOTE 3: For MSR BS supporting multi-band operation with Inter RF bandwidth gap < 20 MHz the test requirement within the Inter RF bandwidth gaps is calculated as a cumulative sum of contributions from adjacent sub-blocks or Base Station RF Bandwidth on each side of the Inter RF bandwidth gap.

4.2.2.2.2 Limits for Band Category 2

For a BS operating in Band Category 2 the requirement shall apply outside the Base Station RF bandwidth edges. In addition, for a BS operating in non-contiguous spectrum, it shall apply inside any sub-block gap.

Outside the Base Station RF bandwidth edges, emissions shall not exceed the maximum levels specified in tables 4.2.2.2.2-1 to 4.2.2.2.2-8, where:

- Δf is the separation between the Base Station RF bandwidth edge frequency and the nominal -3 dB point of the measuring filter closest to the carrier frequency.
- f_{offset} is the separation between the Base Station RF bandwidth edge frequency and the centre of the measuring filter.
- $f_{\text{offset}_{\text{max}}}$ is the offset to the frequency 10 MHz outside the downlink operating band.
- Δf_{max} is equal to $f_{\text{offset}_{\text{max}}}$ minus half of the bandwidth of the measuring filter.

For a BS operating in multiple bands, inside any inter-RF bandwidth gaps with $W_{\text{gap}} < 20$ MHz, emissions shall not exceed the cumulative sum of the test requirements specified at the Base Station RF bandwidth edges on each side of the inter-RF bandwidth gap. The test requirement for Base Station RF bandwidth edge is specified in tables 4.2.2.2.2-1 to 4.2.2.2.2-8, where in this case:

- Δf is the separation between the Base Station RF bandwidth edge frequency and the nominal -3 dB point of the measuring filter closest to the carrier frequency.
- f_{offset} is the separation between the Base Station RF bandwidth edge frequency and the centre of the measuring filter.
- $f_{\text{offset}_{\text{max}}}$ is equal to the Inter RF bandwidth gap minus half of the bandwidth of the measuring filter.
- Δf_{max} is equal to $f_{\text{offset}_{\text{max}}}$ minus half of the bandwidth of the measuring filter.

For a BS capable of multi-band operation where multiple bands are mapped on the same antenna connector and where there is no carrier transmitted in an operating band, no cumulative limits are applied in the inter-band gap between a supported downlink band with carrier(s) transmitted and a supported downlink band without any carrier transmitted; and:

- In case the inter-band gap between a supported downlink band with carrier(s) transmitted and a supported downlink band without any carrier transmitted is less than 20 MHz, $f_{\text{offset}_{\text{max}}}$ shall be the offset to the frequency 10 MHz outside the outermost edges of the two supported downlink operating bands and the operating band unwanted emission limit of the band where there are carriers transmitted, as defined in the tables of the present clause, shall apply across both supported downlink bands.
- In other cases, the operating band unwanted emission limit of the band where there are carriers transmitted, as defined in the tables of the present clause for the largest frequency offset (Δf_{max}), shall apply from 10 MHz below the lowest frequency, up to 10 MHz above the highest frequency of the supported downlink operating band without any carrier transmitted.

Inside any sub-block gap for a BS operating in non-contiguous spectrum, emissions shall not exceed the cumulative sum of the test requirement specified for the adjacent sub-blocks on each side of the sub-block gap. The test requirement for each sub-block is specified in tables 4.2.2.2.2-1 to 4.2.2.2.2-8, where in this case:

- Δf is the separation between the sub-block edge frequency and the nominal -3 dB point of the measuring filter closest to the sub-block edge.
- f_{offset} is the separation between the sub-block edge frequency and the centre of the measuring filter.
- $f_{\text{offset}_{\text{max}}}$ is equal to the sub-block gap bandwidth minus half of the bandwidth of the measuring filter.
- Δf_{max} is equal to $f_{\text{offset}_{\text{max}}}$ minus half of the bandwidth of the measuring filter.

Table 4.2.2.2-1: Wide Area BS operating band unwanted emission mask (UEM) for BC2

Frequency offset of measurement filter -3 dB point, Δf	Frequency offset of measurement filter centre frequency, f_{offset}	Test requirement (see notes 4 and 5)	Measurement bandwidth
$0 \text{ MHz} \leq \Delta f < 0,2 \text{ MHz}$ (see note 1)	$0,015 \text{ MHz} \leq f_{\text{offset}} < 0,215 \text{ MHz}$	-12,5 dBm	30 kHz
$0,2 \text{ MHz} \leq \Delta f < 1 \text{ MHz}$ (see note 2)	$0,215 \text{ MHz} \leq f_{\text{offset}} < 1,015 \text{ MHz}$ $1,015 \text{ MHz} \leq f_{\text{offset}} < 1,5 \text{ MHz}$	$-12,5 \text{ dBm} - 15 \cdot \left(\frac{f_{\text{offset}}}{\text{MHz}} - 0,215 \right) \text{ dB}$ -24,5 dBm	30 kHz 30 kHz
$1 \text{ MHz} \leq \Delta f \leq \min(\Delta f_{\text{max}}, 10 \text{ MHz})$	$1,5 \text{ MHz} \leq f_{\text{offset}} < \min(f_{\text{offset}_{\text{max}}}, 10,5 \text{ MHz})$	-11,5 dBm	1 MHz
$10 \text{ MHz} \leq \Delta f \leq \Delta f_{\text{max}}$	$10,5 \text{ MHz} \leq f_{\text{offset}} < f_{\text{offset}_{\text{max}}}$	-15 dBm (see note 3)	1 MHz

NOTE 1: For operation with a GSM/EDGE or an E-UTRA 1,4 MHz or 3 MHz carrier adjacent to the Base Station RF bandwidth edge, the limits in table 4.2.2.2-2 shall apply for $0 \text{ MHz} \leq \Delta f < 0,15 \text{ MHz}$.

NOTE 2: This frequency range ensures that the range of values of f_{offset} is continuous.

NOTE 3: The requirement is not applicable when $\Delta f_{\text{max}} < 10 \text{ MHz}$.

NOTE 4: For MSR BS supporting non-contiguous spectrum operation within any operating band the test requirement within sub-block gaps is calculated as a cumulative sum of contributions from adjacent sub-blocks on each side of the sub-block gap, where the contribution from the far-end sub-block shall be scaled according to the measurement bandwidth of the near-end sub-block. Exception is $\Delta f \geq 10 \text{ MHz}$ from both adjacent sub-blocks on each side of the sub-block gap, where the test requirement within sub-block gaps shall be -15 dBm/MHz.

NOTE 5: For MSR BS supporting multi-band operation with Inter RF bandwidth gap < 20 MHz operation the test requirement within the Inter RF bandwidth gaps is calculated as a cumulative sum of contributions from adjacent sub-blocks or Base Station RF Bandwidth on each side of the Inter RF bandwidth gap, where the contribution from the far-end sub-block or Base Station RF Bandwidth shall be scaled according to the measurement bandwidth of the near-end sub-block or Base Station RF Bandwidth.

Table 4.2.2.2-2: Wide Area BS operating band unwanted emission limits for operation in BC2 with GSM/EDGE or E-UTRA 1,4 MHz or 3 MHz carriers adjacent to the RF bandwidth edge

Frequency offset of measurement filter -3 dB point, Δf	Frequency offset of measurement filter centre frequency, f_{offset}	Test requirement (see notes 2, 3 and 4)	Measurement bandwidth
$0 \text{ MHz} \leq \Delta f < 0,05 \text{ MHz}$	$0,015 \text{ MHz} \leq f_{\text{offset}} < 0,065 \text{ MHz}$	$\text{Max}(6,5 \text{ dBm} - 60 \cdot \left(\frac{f_{\text{offset}}}{\text{MHz}} - 0,015 \right) \text{ dB} + X \text{ dB}, -12,5 \text{ dBm})$	30 kHz
$0,05 \text{ MHz} \leq \Delta f < 0,15 \text{ MHz}$	$0,065 \text{ MHz} \leq f_{\text{offset}} < 0,165 \text{ MHz}$	$\text{Max}(3,5 \text{ dBm} - 160 \cdot \left(\frac{f_{\text{offset}}}{\text{MHz}} - 0,065 \right) \text{ dB} + X \text{ dB}, -12,5 \text{ dBm})$	30 kHz

NOTE 1: The limits in this table only shall apply for operation with a GSM/EDGE or an E-UTRA 1,4 MHz or 3 MHz carrier adjacent to the Base Station RF bandwidth edge.

NOTE 2: For MSR BS supporting non-contiguous spectrum operation within any operating band the test requirement within sub-block gaps is calculated as a cumulative sum of contributions from adjacent sub-blocks on each side of the sub-block gap.

NOTE 3: In case the carrier adjacent to the Base Station RF bandwidth edge is a GSM/EDGE carrier, the value of $X = P_{\text{GSMcarrier}} - 43$, where $P_{\text{GSMcarrier}}$ is the power level of the GSM/EDGE carrier adjacent to the Base Station RF bandwidth edge. In other cases, $X = 0$.

NOTE 4: For MSR BS supporting multi-band operation with Inter RF bandwidth gap < 20 MHz operation the test requirement within the Inter RF bandwidth gaps is calculated as a cumulative sum of contributions from adjacent sub-blocks or Base Station RF Bandwidth on each side of the Inter RF bandwidth gap.

**Table 4.2.2.2-3: Medium Range BS operating band unwanted emission mask (UEM)
for BC2, BS maximum output power $31 < P_{\max,c} \leq 38$ dBm**

Frequency offset of measurement filter -3 dB point, Δf	Frequency offset of measurement filter centre frequency, f_{offset}	Test requirement (see notes 4 and 5)	Measurement bandwidth
$0 \text{ MHz} \leq \Delta f < 0,6 \text{ MHz}$ (see note 1)	$0,015 \text{ MHz} \leq f_{\text{offset}} < 0,615 \text{ MHz}$	$P_{\max,c} - 56,5 \text{ dB} - \frac{7}{5} \left(\frac{f_{\text{offset}}}{\text{MHz}} - 0,015 \right) \text{ dB}$	30 kHz
$0,6 \text{ MHz} \leq \Delta f < 1 \text{ MHz}$	$0,615 \text{ MHz} \leq f_{\text{offset}} < 1,015 \text{ MHz}$	$P_{\max,c} - 51,5 \text{ dB} - 15 \left(\frac{f_{\text{offset}}}{\text{MHz}} - 0,215 \right) \text{ dB}$	30 kHz
(see note 2)	$1,015 \text{ MHz} \leq f_{\text{offset}} < 1,5 \text{ MHz}$	$P_{\max,c} - 63,5 \text{ dB}$	30 kHz
$1 \text{ MHz} \leq \Delta f \leq 2,8 \text{ MHz}$	$1,5 \text{ MHz} \leq f_{\text{offset}} < 3,3 \text{ MHz}$	$P_{\max,c} - 50,5 \text{ dB}$	1 MHz
$2,8 \text{ MHz} \leq \Delta f \leq 5 \text{ MHz}$	$3,3 \text{ MHz} \leq f_{\text{offset}} < 5,5 \text{ MHz}$	$\min(P_{\max,c} - 50,5 \text{ dB}, -13,5 \text{ dBm})$	1 MHz
$5 \text{ MHz} \leq \Delta f \leq \min(\Delta f_{\max}, 10 \text{ MHz})$	$5,5 \text{ MHz} \leq f_{\text{offset}} < \min(f_{\text{offset}_{\max}}, 10,5 \text{ MHz})$	$P_{\max,c} - 54,5 \text{ dB}$	1 MHz
$10 \text{ MHz} \leq \Delta f \leq \Delta f_{\max}$	$10,5 \text{ MHz} \leq f_{\text{offset}} < f_{\text{offset}_{\max}}$	$P_{\max,c} - 56 \text{ dB}$ (see note 3)	1 MHz

NOTE 1: For operation with a GSM/EDGE or an E-UTRA 1,4 or 3 MHz carrier adjacent to the Base Station RF bandwidth edge, the limits in table 4.2.2.2-5 shall apply for $0 \text{ MHz} \leq \Delta f < 0,15 \text{ MHz}$.

NOTE 2: This frequency range ensures that the range of values of f_{offset} is continuous.

NOTE 3: The requirement is not applicable when $\Delta f_{\max} < 10 \text{ MHz}$.

NOTE 4: For MSR BS supporting non-contiguous spectrum operation within any operating band the test requirement within sub-block gaps is calculated as a cumulative sum of contributions from adjacent sub-blocks on each side of the sub-block gap, where the contribution from the far-end sub-block shall be scaled according to the measurement bandwidth of the near-end sub-block. Exception is $\Delta f \geq 10 \text{ MHz}$ from both adjacent sub-blocks on each side of the sub-block gap, where the test requirement within sub-block gaps shall be $(P_{\max,c} - 56 \text{ dB})/\text{MHz}$.

NOTE 5: For MSR BS supporting multi-band operation with Inter RF bandwidth gap $< 20 \text{ MHz}$ operation the test requirement within the Inter RF bandwidth gaps is calculated as a cumulative sum of contributions from adjacent sub-blocks or Base Station RF Bandwidth on each side of the Inter RF bandwidth gap, where the contribution from the far-end sub-block or Base Station RF Bandwidth shall be scaled according to the measurement bandwidth of the near-end sub-block or Base Station RF Bandwidth.

**Table 4.2.2.2-4: Medium Range BS operating band unwanted emission mask (UEM)
for BC2, BS maximum output power $P_{\max,c} \leq 31$ dBm**

Frequency offset of measurement filter -3 dB point, Δf	Frequency offset of measurement filter centre frequency, f_{offset}	Test requirement (see notes 4 and 5)	Measurement bandwidth
$0 \text{ MHz} \leq \Delta f < 0,6 \text{ MHz}$ (see note 1)	$0,015 \text{ MHz} \leq f_{\text{offset}} < 0,615 \text{ MHz}$	$-25,5 \text{ dBm} - \frac{7}{5} \left(\frac{f_{\text{offset}}}{\text{MHz}} - 0,015 \right) \text{ dB}$	30 kHz
$0,6 \text{ MHz} \leq \Delta f < 1 \text{ MHz}$	$0,615 \text{ MHz} \leq f_{\text{offset}} < 1,015 \text{ MHz}$	$-20,5 \text{ dBm} - 15 \cdot \left(\frac{f_{\text{offset}}}{\text{MHz}} - 0,215 \right) \text{ dB}$	30 kHz
(see note 2)	$1,015 \text{ MHz} \leq f_{\text{offset}} < 1,5 \text{ MHz}$	-32,5 dBm	30 kHz
$1 \text{ MHz} \leq \Delta f \leq 5 \text{ MHz}$	$1,5 \text{ MHz} \leq f_{\text{offset}} < 5,5 \text{ MHz}$	-19,5 dBm	1 MHz
$5 \text{ MHz} \leq \Delta f \leq \min(\Delta f_{\max}, 10 \text{ MHz})$	$5,5 \text{ MHz} \leq f_{\text{offset}} < \min(f_{\text{offset}_{\max}}, 10,5 \text{ MHz})$	-23,5 dBm	1 MHz
$10 \text{ MHz} \leq \Delta f \leq \Delta f_{\max}$	$10,5 \text{ MHz} \leq f_{\text{offset}} < f_{\text{offset}_{\max}}$	-25 dBm (see note 3)	1 MHz

NOTE 1: For operation with a GSM/EDGE or an E-UTRA 1,4 or 3 MHz carrier adjacent to the Base Station RF bandwidth edge, the limits in table 4.2.2.2-6 shall apply for $0 \text{ MHz} \leq \Delta f < 0,15 \text{ MHz}$.

NOTE 2: This frequency range ensures that the range of values of f_{offset} is continuous.

NOTE 3: The requirement is not applicable when $\Delta f_{\max} < 10 \text{ MHz}$.

NOTE 4: For MSR BS supporting non-contiguous spectrum operation within any operating band the test requirement within sub-block gaps is calculated as a cumulative sum of contributions from adjacent sub-blocks on each side of the sub-block gap, where the contribution from the far-end sub-block shall be scaled according to the measurement bandwidth of the near-end sub-block. Exception is $\Delta f \geq 10 \text{ MHz}$ from both adjacent sub-blocks on each side of the sub-block gap, where the test requirement within sub-block gaps shall be $-25 \text{ dBm}/\text{MHz}$.

NOTE 5: For MSR BS supporting multi-band operation with Inter RF bandwidth gap $< 20 \text{ MHz}$ operation the test requirement within the Inter RF bandwidth gaps is calculated as a cumulative sum of contributions from adjacent sub-blocks or Base Station RF Bandwidth on each side of the Inter RF bandwidth gap, where the contribution from the far-end sub-block or Base Station RF Bandwidth shall be scaled according to the measurement bandwidth of the near-end sub-block or Base Station RF Bandwidth.

Table 4.2.2.2-5: Medium Range operating band unwanted emission limits for operation in BC2 with GSM/EDGE or E-UTRA 1,4 or 3 MHz carriers adjacent to the Base Station RF bandwidth edge, BS maximum output power $31 < P_{\max,c} \leq 38$ dBm

Frequency offset of measurement filter -3 dB point, Δf	Frequency offset of measurement filter centre frequency, f_{offset}	Test requirement (see notes 2 and 3)	Measurement bandwidth
$0 \text{ MHz} \leq \Delta f < 0,05 \text{ MHz}$	$0,015 \text{ MHz} \leq f_{\text{offset}} < 0,065 \text{ MHz}$	$P_{\max,c} - 36,5 \text{ dB} - 60 \left(\frac{f_{\text{offset}}}{\text{MHz}} - 0,015 \right) \text{ dB}$	30 kHz
$0,05 \text{ MHz} \leq \Delta f < 0,15 \text{ MHz}$	$0,065 \text{ MHz} \leq f_{\text{offset}} < 0,165 \text{ MHz}$	$P_{\max,c} - 39,5 \text{ dB} - 160 \left(\frac{f_{\text{offset}}}{\text{MHz}} - 0,065 \right) \text{ dB}$	30 kHz

NOTE 1: The limits in this table only shall apply for operation with a GSM/EDGE or an E-UTRA 1,4 or 3 MHz carrier adjacent to the Base Station RF bandwidth edge.

NOTE 2: For MSR BS supporting non-contiguous spectrum operation within any operating band the test requirement within sub-block gaps is calculated as a cumulative sum of contributions from adjacent sub-blocks on each side of the sub-block gap.

NOTE 3: For MSR BS supporting multi-band operation with Inter RF bandwidth gap < 20 MHz operation the test requirement within the Inter RF bandwidth gaps is calculated as a cumulative sum of contributions from adjacent sub-blocks or Base Station RF Bandwidth on each side of the Inter RF bandwidth gap.

Table 4.2.2.2-6: Medium Range operating band unwanted emission limits for operation in BC2 with GSM/EDGE or E-UTRA 1,4 or 3 MHz carriers adjacent to the Base Station RF bandwidth edge, BS maximum output power $P_{\max,c} \leq 31$ dBm

Frequency offset of measurement filter -3 dB point, Δf	Frequency offset of measurement filter centre frequency, f_{offset}	Test requirement (see notes 2, 3 and 4)	Measurement bandwidth
$0 \text{ MHz} \leq \Delta f < 0,05 \text{ MHz}$	$0,015 \text{ MHz} \leq f_{\text{offset}} < 0,065 \text{ MHz}$	$\text{Max}(-5,5 \text{ dBm} - 60 \cdot \left(\frac{f_{\text{offset}}}{\text{MHz}} - 0,015 \right) \text{ dB} + X \text{ dB}, -25,5 \text{ dBm})$	30 kHz
$0,05 \text{ MHz} \leq \Delta f < 0,15 \text{ MHz}$	$0,065 \text{ MHz} \leq f_{\text{offset}} < 0,165 \text{ MHz}$	$\text{Max}(-8,5 \text{ dBm} - 160 \cdot \left(\frac{f_{\text{offset}}}{\text{MHz}} - 0,065 \right) \text{ dB} + X \text{ dB}, -25,5 \text{ dBm})$	30 kHz

NOTE 1: The limits in this table only shall apply for operation with a GSM/EDGE or an E-UTRA 1,4 or 3 MHz carrier adjacent to the Base Station RF bandwidth edge.

NOTE 2: For MSR BS supporting non-contiguous spectrum operation within any operating band the test requirement within sub-block gaps is calculated as a cumulative sum of contributions from adjacent sub-blocks on each side of the sub-block gap.

NOTE 3: In case the carrier adjacent to the Base Station RF bandwidth edge is a GSM/EDGE carrier, the value of $X = P_{\text{GSMcarrier}} - 31$, where $P_{\text{GSMcarrier}}$ is the power level of the GSM/EDGE carrier adjacent to the Base Station RF bandwidth edge. In other cases, $X = 0$.

NOTE 4: For MSR BS supporting multi-band operation with Inter RF bandwidth gap < 20 MHz operation the test requirement within the Inter RF bandwidth gaps is calculated as a cumulative sum of contributions from adjacent sub-blocks or Base Station RF Bandwidth on each side of the Inter RF bandwidth gap.

Table 4.2.2.2-7: Local Area operating band unwanted emission mask (UEM) for BC2

Frequency offset of measurement filter -3 dB point, Δf	Frequency offset of measurement filter centre frequency, f_{offset}	Test requirement (see notes 3 and 4)	Measurement bandwidth
$0 \text{ MHz} \leq \Delta f < 5 \text{ MHz}$ (see note 1)	$0,05 \text{ MHz} \leq f_{\text{offset}} < 5,05 \text{ MHz}$	$-28,5 \text{ dBm} - \frac{7}{5} \left(\frac{f_{\text{offset}}}{\text{MHz}} - 0,05 \right) \text{ dB}$	100 kHz
$5 \text{ MHz} \leq \Delta f < \min(10 \text{ MHz}, \Delta f_{\text{max}})$	$5,05 \text{ MHz} \leq f_{\text{offset}} < \min(10,05 \text{ MHz}, f_{\text{offset}_{\text{max}}})$	-35,5 dBm	100 kHz
$10 \text{ MHz} \leq \Delta f \leq \Delta f_{\text{max}}$	$10,05 \text{ MHz} \leq f_{\text{offset}} < f_{\text{offset}_{\text{max}}}$	-37 dBm (see note 2)	100 kHz

NOTE 1: For operation with a GSM/EDGE or an E-UTRA 1,4 or 3 MHz carrier adjacent to the Base Station RF bandwidth edge, the limits in table 4.2.2.2-8 shall apply for $0 \text{ MHz} \leq \Delta f < 0,16 \text{ MHz}$.

NOTE 2: The requirement is not applicable when $\Delta f_{\text{max}} < 10 \text{ MHz}$.

NOTE 3: For MSR BS supporting non-contiguous spectrum operation within any operating band the test requirement within sub-block gaps is calculated as a cumulative sum of contributions from adjacent sub-blocks on each side of the sub-block gap. Exception is $\Delta f \geq 10 \text{ MHz}$ from both adjacent sub-blocks on each side of the sub-block gap, where the test requirement within sub-block gaps shall be -37 dBm/100 kHz.

NOTE 4: For MSR BS supporting multi-band operation with Inter RF bandwidth gap < 20 MHz operation the test requirement within the Inter RF bandwidth gaps is calculated as a cumulative sum of contributions from adjacent sub-blocks or Base Station RF Bandwidth on each side of the Inter RF bandwidth gap.

Table 4.2.2.2-8: Local Area operating band unwanted emission limits for operation in BC2 with GSM/EDGE or E-UTRA 1,4 or 3 MHz carriers adjacent to the Base Station RF bandwidth edge

Frequency offset of measurement filter -3 dB point, Δf	Frequency offset of measurement filter centre frequency, f_{offset}	Test requirement (see notes 2, 3 and 4)	Measurement bandwidth
$0 \text{ MHz} \leq \Delta f < 0,05 \text{ MHz}$	$0,015 \text{ MHz} \leq f_{\text{offset}} < 0,065 \text{ MHz}$	$\text{Max}(-12,5 \text{ dBm} - 60 \cdot \left(\frac{f_{\text{offset}}}{\text{MHz}} - 0,015 \right) \text{ dB} + X \text{ dB}, -33,5 \text{ dBm})$	30 kHz
$0,05 \text{ MHz} \leq \Delta f < 0,16 \text{ MHz}$	$0,065 \text{ MHz} \leq f_{\text{offset}} < 0,175 \text{ MHz}$	$\text{Max}(-15,5 \text{ dBm} - 160 \cdot \left(\frac{f_{\text{offset}}}{\text{MHz}} - 0,065 \right) \text{ dB} + X \text{ dB}, -33,5 \text{ dBm})$	30 kHz

NOTE 1: The limits in this table only shall apply for operation with a GSM/EDGE or an E-UTRA 1,4 or 3 MHz carrier adjacent to the Base Station RF bandwidth edge.

NOTE 2: For MSR BS supporting non-contiguous spectrum operation within any operating band the test requirement within sub-block gaps is calculated as a cumulative sum of contributions from adjacent sub-blocks on each side of the sub-block gap.

NOTE 3: In case the carrier adjacent to the Base Station RF bandwidth edge is a GSM/EDGE carrier, the value of $X = P_{\text{GSMcarrier}} - 24$, where $P_{\text{GSMcarrier}}$ is the power level of the GSM/EDGE carrier adjacent to the Base Station RF bandwidth edge. In other cases, $X = 0$.

NOTE 4: For MSR BS supporting multi-band operation with Inter RF bandwidth gap < 20 MHz operation the test requirement within the Inter RF bandwidth gaps is calculated as a cumulative sum of contributions from adjacent sub-blocks or Base Station RF Bandwidth on each side of the Inter RF bandwidth gap.

4.2.2.2.3 Limits for GSM/EDGE single-RAT operation

The following test requirements and the corresponding test method specified in ETSI EN 301 502 [9] shall apply to an MSR Base Station for any operating band with GSM/EDGE single RAT operation in Band Category 2:

- Spectrum due to the modulation and wide band noise, applicable parts of clause 4.2.4.1 of ETSI EN 301 502 [9].
- Spectrum due to switching transients, applicable parts of clause 4.2.4.2 of ETSI EN 301 502 [9].
- Emission requirement for frequency offsets of between 2 MHz and 10 MHz outside relevant transmit band, applicable parts of clause 4.2.5.2 of ETSI EN 301 502 [9].
- Intra BTS Intermodulation, applicable parts of clause 4.2.8 of ETSI EN 301 502 [9].

4.2.2.2.4 Limits for protection of DTT

For a BS operating in Band 20, the level of emissions in the band 470 MHz to 790 MHz, measured in an 8 MHz filter bandwidth on centre frequencies F_{filter} according to table 4.2.2.2.4-1, shall not exceed the maximum emission level $P_{\text{EM},N}$ declared by the manufacturer. This requirement shall apply in the frequency range 470 MHz to 790 MHz even though part of the range falls in the spurious domain.

Table 4.2.2.2.4-1: Declared emissions levels for protection of DTT

Filter centre frequency, F_{filter}	Measurement bandwidth	Declared emission level [dBm]
$F_{\text{filter}} = 8 \times N + 306$ (MHz); $21 \leq N \leq 60$	8 MHz	$P_{\text{EM},N}$

NOTE: Compliance with the declared emission levels above provides the characteristics of the Base Station needed to verify compliance with the corresponding CEPT/ECC technical condition using the method outlined in annex G of ETSI TS 136 104 [4].

4.2.2.2.5 Limits for co-existence with services in adjacent frequency bands

The following requirement shall apply for the protection of systems operating in frequency bands adjacent to Band 1. The power of any spurious emission shall not exceed the limits specified in table 4.2.2.2.5-1.

Table 4.2.2.2.5-1: Emissions limits for protection of adjacent band services

Operating Band	Frequency range	Maximum Level	Measurement Bandwidth
1	2 100 MHz to 2 105 MHz	$-30 + 3,4 \times (f/\text{MHz} - 2 100)$ dBm	1 MHz
	2 175 MHz to 2 180 MHz	$-30 + 3,4 \times (2 180 - f/\text{MHz})$ dBm	1 MHz

4.2.2.2.6 Limits for operation in Band 32

For a BS operating in Band 32 within 1 452 MHz to 1 492 MHz, the level of operating band unwanted emissions, measured on centre frequencies f_{offset} with filter bandwidth according to table 4.2.2.2.6-1, shall not exceed the maximum emission level $P_{\text{EM},B32,a}$, $P_{\text{EM},B32,b}$ and $P_{\text{EM},B32,c}$ declared by the manufacturer.

Table 4.2.2.2.6-1: Declared operating band 32 unwanted emission within 1 452 MHz to 1 492 MHz

Frequency offset of measurement filter centre frequency, f_{offset}	Declared emission level [dBm]	Measurement bandwidth
2,5 MHz	$P_{\text{EM},B32,a}$	5 MHz
7,5 MHz	$P_{\text{EM},B32,b}$	5 MHz
$12,5 \text{ MHz} \leq f_{\text{offset}} \leq f_{\text{offset}_{\text{max}, B32}}$	$P_{\text{EM},B32,c}$	5 MHz
NOTE: $f_{\text{offset}_{\text{max}, B32}}$ denotes the frequency difference between the lower Base Station RF bandwidth edge and 1 454,5 MHz, and the frequency difference between the upper Base Station RF bandwidth edge and 1 489,5 MHz for the set channel position.		

NOTE 1: Compliance with the declared emission levels above provides the characteristics of the Base Station needed to verify compliance with the corresponding CEPT/ECC technical condition using the method outlined in annex H of ETSI TS 136 104 [8].

For a BS operating in Band 32 within 1 452 MHz to 1 492 MHz, for the protection of services in spectrum adjacent to the frequency range 1 452 MHz to 1 492 MHz, the level of emissions measured on centre frequencies F_{filter} with filter bandwidth according to table 4.2.2.2.6-2, shall not exceed the maximum emission level $P_{\text{EM},B32,d}$ and $P_{\text{EM},B32,e}$ declared by the manufacturer. This requirement applies in the frequency range 1 429 MHz to 1 518 MHz even though part of the range falls in the spurious domain.

Table 4.2.2.6-2: Operating band 32 declared emission outside 1 452 MHz to 1 492 MHz

Filter centre frequency, F_{filter}	Declared emission level [dBm]	Measurement bandwidth
$1\,429,5\text{ MHz} \leq F_{\text{filter}} \leq 1\,448,5\text{ MHz}$	$P_{\text{EM,B32,d}}$	1 MHz
$F_{\text{filter}} = 1\,450,5\text{ MHz}$	$P_{\text{EM,B32,e}}$	3 MHz
$F_{\text{filter}} = 1\,493,5\text{ MHz}$	$P_{\text{EM,B32,e}}$	3 MHz
$1\,495,5\text{ MHz} \leq F_{\text{filter}} \leq 1\,517,5\text{ MHz}$	$P_{\text{EM,B32,d}}$	1 MHz

NOTE 2: Compliance with the declared emission levels above provides the characteristics of the Base Station needed to verify compliance with the corresponding CEPT/ECC technical condition using the method outlined in annex H of ETSI TS 136 104 [8].

4.2.2.3 Conformance

Conformance tests described in clause 5.3.1 shall be carried out.

4.2.3 Adjacent Channel Leakage power Ratio (ACLR)

4.2.3.1 Definition

Unwanted emissions consist of out-of-band emissions and spurious emissions (Recommendation ITU-R SM.329-12 [i.5]). Out of band emissions are emissions immediately outside the channel bandwidth resulting from the modulation process and non-linearity in the transmitter but excluding spurious emissions. The out-of-band emissions requirement for the BS transmitter is specified both in terms of Adjacent Channel Leakage power Ratio (ACLR) and Operating band unwanted emissions.

Adjacent Channel Leakage power Ratio (ACLR) is the ratio of the filtered mean power centred on the assigned channel frequency to the filtered mean power centred on an adjacent channel frequency.

4.2.3.2 Limits

4.2.3.2.1 E-UTRA limits

For E-UTRA, the limits are specified in ETSI EN 301 908-14 [7], clause 4.2.3, and shall apply outside the Base Station RF bandwidth or Maximum Radio Bandwidth.

For a BS operating in non-contiguous spectrum, the ACLR shall also apply for the first adjacent channel inside any sub-block gap with a gap size $W_{\text{gap}} \geq 15\text{ MHz}$. The ACLR requirement for the second adjacent channel shall apply inside any sub-block gap with a gap size $W_{\text{gap}} \geq 20\text{ MHz}$. The ACLR test requirement in clause 4.2.3.2.4 shall apply in sub-block gaps for the frequency ranges defined in table 4.2.3.2.4-1.

For a BS operating in multiple bands, where multiple bands are mapped onto the same antenna connector, the ACLR shall also apply for the first adjacent channel inside any Inter RF bandwidth gap with a gap size $W_{\text{gap}} \geq 15\text{ MHz}$. The ACLR requirement for the second adjacent channel shall apply inside any Inter RF bandwidth gap with a gap size $W_{\text{gap}} \geq 20\text{ MHz}$. The ACLR requirement in clause 4.2.3.2.4 shall apply in Inter RF bandwidth gaps for the frequency ranges defined in table 4.2.3.2.4-1.

4.2.3.2.2 UTRA FDD limits

For UTRA FDD, the limits are specified in ETSI EN 301 908-3 [6], clause 4.2.3, and shall apply outside the Base Station RF bandwidth or Maximum Radio Bandwidth.

For a BS operating in non-contiguous spectrum, ACLR requirement shall also apply for the first adjacent channel, inside any sub-block gap with a gap size $W_{\text{gap}} \geq 15\text{ MHz}$. The ACLR requirement for the second adjacent channel shall apply inside any sub-block gap with a gap size $W_{\text{gap}} \geq 20\text{ MHz}$. The ACLR test requirement in clause 4.2.3.2.4 shall apply in sub-block gaps for the frequency ranges defined in table 4.2.3.2.4-1.

For a BS operating in multiple bands, where multiple bands are mapped onto the same antenna connector, ACLR requirement shall also apply for the first adjacent channel, inside any Inter RF bandwidth gap with a gap size $W_{\text{gap}} \geq 15$ MHz. The ACLR requirement for the second adjacent channel shall apply inside any Inter RF bandwidth gap with a gap size $W_{\text{gap}} \geq 20$ MHz. The CACLR requirement in clause 4.2.3.2.4 shall apply in Inter RF bandwidth gaps for the frequency ranges defined in table 4.2.3.2.4-1.

4.2.3.2.3 UTRA TDD limits

For UTRA TDD, the limits are specified in ETSI TS 125 142 [13], clause 6.6.2.2.5, and shall apply outside the Base Station RF bandwidth or Maximum Radio Bandwidth.

4.2.3.2.4 Cumulative ACLR requirement in non-contiguous spectrum

The following requirement shall apply for the sub-block or Inter RF bandwidth gap sizes listed in table 4.2.3.2.4-1:

- Inside a sub-block gap within an operating band for a BS operating in non-contiguous spectrum.
- Inside an Inter RF bandwidth gap for a BS operating in multiple bands, where multiple bands are mapped on the same antenna connector.

The Cumulative Adjacent Channel Leakage power Ratio (CACLR) in a sub-block gap or the Inter RF bandwidth gap is the ratio of:

- a) the sum of the filtered mean power centred on the assigned channel frequencies for the two carriers adjacent to each side of the sub-block gap or the Inter RF bandwidth gap; and
- b) the filtered mean power centred on a frequency channel adjacent to one of the respective sub-block edges or Base Station RF bandwidth edges.

The requirement shall apply to adjacent channels of E-UTRA or UTRA carriers allocated adjacent to each side of the sub-block gap or the Inter RF bandwidth gap. The assumed filter for the adjacent channel frequency is defined in table 4.2.3.2.4-1 and the filters on the assigned channels are defined in table 4.2.3.2.4-2.

NOTE: If the RAT on the assigned channel frequencies are different, the filters used are also different.

For Wide Area BS, either the CACLR limits in table 4.2.3.2.4-1 or the absolute limit of -15 dBm/MHz shall apply, whichever is less stringent.

For Medium Range BS, either the CACLR limits in table 4.2.3.2.4-1 or the absolute limit of -25 dBm/MHz shall apply, whichever is less stringent.

For Local Area BS, either the CACLR limits in table 4.2.3.2.4-1 or the absolute limit of -32 dBm/MHz shall apply, whichever is less stringent.

The CACLR for E-UTRA and UTRA carriers located on either side of the sub-block gap or the Inter RF bandwidth gap shall be higher than the value specified in table 4.2.3.2.4-1.

Table 4.2.3.2.4-1: Base Station CACLR in non-contiguous spectrum or multiple bands

Band Category	Sub-block or Inter RF bandwidth gap size (W_{gap}) where the limit applies	BS adjacent channel centre frequency offset below or above the sub-block edge or the Base Station RF bandwidth edge (inside the gap)	Assumed adjacent channel carrier (informative)	Filter on the adjacent channel frequency and corresponding filter bandwidth	CACLR limit
BC1, BC2	$5 \text{ MHz} \leq W_{\text{gap}} < 15 \text{ MHz}$	2,5 MHz	3,84 Mcps UTRA	RRC (3,84 Mcps)	44,2 dB
BC1, BC2	$10 \text{ MHz} \leq W_{\text{gap}} < 20 \text{ MHz}$	7,5 MHz	3,84 Mcps UTRA	RRC (3,84 Mcps)	44,2 dB
BC3	$5 \text{ MHz} \leq W_{\text{gap}} < 15 \text{ MHz}$	2,5 MHz	5 MHz E-UTRA	Square (BW_{Config})	44,2 dB
BC3	$10 \text{ MHz} < W_{\text{gap}} < 20 \text{ MHz}$	7,5 MHz	5 MHz E-UTRA	Square (BW_{Config})	44,2 dB

NOTE: For BC1 and BC2 the RRC filter shall be equivalent to the transmit pulse shape filter defined in ETSI TS 125 104 [2], with a chip rate as defined in this table.

Table 4.2.3.2.4-2: Filter parameters for the assigned channel

RAT of the carrier adjacent to the sub-block or Inter RF bandwidth gap	Filter on the assigned channel frequency and corresponding filter bandwidth
E-UTRA	E-UTRA of same BW
UTRA FDD	RRC (3,84 Mcps)

NOTE: The RRC filter shall be equivalent to the transmit pulse shape filter defined in ETSI TS 125 104 [2], with a chip rate as defined in this table.

4.2.3.3 Conformance

Conformance tests described in clause 5.3.2 shall be carried out.

4.2.4 Transmitter spurious emissions

4.2.4.1 Definition

Unwanted emissions consist of out-of-band emissions and spurious emissions (Recommendation ITU-R SM.329-12 [i.5]). Spurious emissions are emissions which are caused by unwanted transmitter effects such as harmonics emission, parasitic emission, intermodulation products and frequency conversion products, but exclude out-of-band emissions. This is measured at the Base Station antenna connector.

The transmitter spurious emission limits shall apply from 9 kHz to 12,75 GHz, excluding the frequency range from 10 MHz below the lowest frequency of the downlink operating band up to 10 MHz above the highest frequency of the downlink operating band. For BS capable of multi-band operation where multiple bands are mapped on the same antenna connector, this exclusion shall apply for each supported operating band. For BS capable of multi-band operation where multiple bands are mapped on separate antenna connectors, the single-band requirements shall apply and the multi-band exclusions and provisions are not applicable. For some operating bands the upper frequency limit is higher than 12,75 GHz.

The requirements shall apply whatever the type of transmitter considered. It shall apply for all transmission modes foreseen by the manufacturer's specification. Unless otherwise stated, all requirements are measured as mean power (RMS).

4.2.4.2 Limits

4.2.4.2.1 Spurious emissions

The power of any spurious emission shall not exceed the limits in table 4.2.4.2.1-1.

Table 4.2.4.2.1-1: BS Spurious emissions limits

Frequency range	Maximum Level	Measurement Bandwidth	Note
9 kHz ↔ 150 kHz	-36 dBm	1 kHz	Note 1
150 kHz ↔ 30 MHz	-36 dBm	10 kHz	Note 1
30 MHz ↔ 1 GHz	-36 dBm	100 kHz	Note 1
1 GHz ↔ 12,75 GHz	-30 dBm	1 MHz	Note 2
12,75 GHz ↔ 5 th harmonic of the upper frequency edge of the downlink operating band	-30 dBm	1 MHz	Notes 2 and 3
NOTE 1: Bandwidth as in Recommendation ITU-R SM.329-12 [i.5], section 4.1.			
NOTE 2: Bandwidth as in Recommendation ITU-R SM.329-12 [i.5], section 4.1. Upper frequency as in Recommendation ITU-R SM.329-12 [i.5], section 2.5, table 1.			
NOTE 3: Shall apply only for Bands 22, 42 and 43.			

4.2.4.2.2 Additional spurious emissions requirement for BC2

For a BS operating in Band Category 2 when GSM/EDGE is configured, the power of any spurious emission shall not exceed the limits in table 4.2.4.2.2-1.

For BS capable of multi-band operation, the limits in table 4.2.4.2.2-1 are only applicable when all supported operating bands belong to BC2 and GSM/EDGE is configured in all bands.

Table 4.2.4.2.2-1: Additional BS Spurious emissions limits for BC2, Category B

Frequency range	Frequency offset from transmitter operating band edge (see note)	Maximum Level	Measurement Bandwidth
500 MHz ↔ 1 GHz	10 MHz to 20 MHz	-36 dBm	300 kHz
	20 MHz to 30 MHz	-36 dBm	1 MHz
	≥ 30 MHz	-36 dBm	3 MHz
1 GHz ↔ 12,75 GHz	≥ 30 MHz	-30 dBm	3 MHz
NOTE: For BS capable of multi-band operation, the frequency offset is relative to the closest operating band.			

4.2.4.2.3 Co-existence with other systems

This requirement shall be applied for the protection of UE/MS and BS/BTS receivers of other systems.

The power of any spurious emission shall not exceed the limit specified in table 4.2.4.2.3-1. For BS capable of multi-band operation, the exclusions and conditions in the Note column of table 4.2.4.2.3-1 shall apply for each supported operating band. For BS capable of multi-band operation where multiple bands are mapped on separate antenna connectors, the exclusions and conditions in the Note column of table 4.2.4.2.3-1 shall apply for the operating band supported at that antenna connector.

Table 4.2.4.2.3-1: Spurious emissions limits for protection of other systems

Protected system	Frequency range for co-existence requirement	Maximum Level	Measurement Bandwidth	Note
GSM900	921 MHz to 960 MHz	-57 dBm	100 kHz	This requirement shall not apply to BS operating in Band 8.
	876 MHz to 915 MHz	-61 dBm	100 kHz	For the frequency range 880 MHz to 915 MHz, this requirement shall not apply to BS operating in Band 8, since it is already covered by the requirement in clause 4.2.4.2.4.
DCS1800	1 805 MHz to 1 880 MHz	-47 dBm	100 kHz	This requirement shall not apply to BS operating in Band 3.
	1 710 MHz to 1 785 MHz	-61 dBm	100 kHz	This requirement shall not apply to BS operating in Band 3, since it is already covered by the requirement in clause 4.2.4.2.4.
UTRA FDD Band I or E-UTRA Band 1	2 110 MHz to 2 170 MHz	-52 dBm	1 MHz	This requirement shall not apply to BS operating in Band 1.
	1 920 MHz to 1 980 MHz	-49 dBm	1 MHz	This requirement shall not apply to BS operating in Band 1, since it is already covered by the requirement in clause 4.2.4.2.4.
UTRA FDD Band III or E-UTRA Band 3	1 805 MHz to 1 880 MHz	-52 dBm	1 MHz	This requirement shall not apply to BS operating in Band 3.
	1 710 MHz to 1 785 MHz	-49 dBm	1 MHz	This requirement shall not apply to BS operating in Band 3, since it is already covered by the requirement in clause 4.2.4.2.4.
UTRA FDD Band VII or E-UTRA Band 7	2 620 MHz to 2 690 MHz	-52 dBm	1 MHz	This requirement shall not apply to BS operating in Band 7.
	2 500 MHz to 2 570 MHz	-49 dBm	1 MHz	This requirement shall not apply to BS operating in Band 7, since it is already covered by the requirement in clause 4.2.4.2.4.
UTRA FDD Band VIII or E-UTRA Band 8	925 MHz to 960 MHz	-52 dBm	1 MHz	This requirement shall not apply to BS operating in Band 8.
	880 MHz to 915 MHz	-49 dBm	1 MHz	This requirement shall not apply to BS operating in Band 8, since it is already covered by the requirement in clause 4.2.4.2.4.
UTRA FDD Band XV	2 600 MHz to 2 620 MHz	-52 dBm	1 MHz	This requirement shall not apply to BS operating in Band 7 or Band 38.
	1 900 MHz to 1 920 MHz	-49 dBm	1 MHz	This requirement shall not apply to BS operating in Band 33.
UTRA FDD Band XVI	2 585 MHz to 2 600 MHz	-52 dBm	1 MHz	This requirement shall not apply to BS operating in Band 7 or Band 38.
	2 010 MHz to 2 025 MHz	-49 dBm	1 MHz	This requirement shall not apply to BS operating in Band 34.
UTRA FDD Band XX or E-UTRA Band 20	791 MHz to 821 MHz	-52 dBm	1 MHz	This requirement shall not apply to BS operating in Band 20 or 28.
	832 MHz to 862 MHz	-49 dBm	1 MHz	This requirement shall not apply to BS operating in Band 20, since it is already covered by the requirement in clause 4.2.4.2.4.
UTRA FDD Band XXII or E-UTRA Band 22	3 510 MHz to 3 590 MHz	-52 dBm	1 MHz	This requirement shall not apply to BS operating in Band 22 or Band 42.
	3 410 MHz to 3 490 MHz	-49 dBm	1 MHz	This requirement shall not apply to BS operating in Band 22, since it is already covered by the requirement in clause 4.2.4.2.4. This requirement shall not apply to Band 42.
E-UTRA Band 28	758 MHz to 803 MHz	-52 dBm	1 MHz	This requirement shall not apply to BS operating in band 20 or 28.
	703 MHz to 748 MHz	-49 dBm	1 MHz	This requirement shall not apply to BS operating in band 28, since it is already covered by the requirement in clause 6.6.1.5.4.
UTRA FDD Band XXXII or E-UTRA Band 32	1 452 MHz to 1 496 MHz	-52 dBm	1 MHz	This requirement shall not apply to BS operating in band 32.

Protected system	Frequency range for co-existence requirement	Maximum Level	Measurement Bandwidth	Note
UTRA TDD Band a) or E-UTRA Band 33	1 900 MHz to 1 920 MHz	-52 dBm	1 MHz	This requirement shall not apply to BS operating in Band 33.
UTRA TDD Band a) or E-UTRA Band 34	2 010 MHz to 2 025 MHz	-52 dBm	1 MHz	This requirement shall not apply to BS operating in Band 34.
UTRA TDD Band d) or E-UTRA Band 38	2 570 MHz to 2 620 MHz	-52 dBm	1 MHz	This requirement shall not apply to BS operating in Band 38. For operation in band 7, see note 2.
E-UTRA Band 40	2 300 MHz to 2 400 MHz	-52 dBm	1 MHz	This requirement shall not apply to BS operating in Band 40.
E-UTRA Band 42	3 400 MHz to 3 600 MHz	-52 dBm	1 MHz	This is not applicable to BS operating in Band 42 or Band 43.
E-UTRA Band 43	3 600 MHz to 3 800 MHz	-52 dBm	1 MHz	This is not applicable to BS operating in Band 42 or Band 43.
NOTE 1: Where the table has two entries for the same or overlapping frequency ranges, both limits shall be applied.				
NOTE 2: As set out in the definition in clause 4.2.4.1, the co-existence requirements in this table shall not apply for the 10 MHz frequency range immediately outside the downlink operating band (see table 1-1). This is also the case when the downlink operating band is adjacent to the Band for the protected system in the table.				

4.2.4.2.4 Protection of the BS receiver of own or different BS

This requirement shall be applied for FDD operation in order to prevent the receivers of the Base Stations being desensitized by emissions from the BS transmitter. It is measured at the transmit antenna port for any type of BS which has common or separate Tx/Rx antenna ports.

The power of any spurious emission shall not exceed the limits in table 4.2.4.2.4-1.

Table 4.2.4.2.4-1: BS Spurious emissions limits for protection of the BS receiver

BS Class	Band category	Frequency range	Maximum Level	Measurement Bandwidth	Note
Wide Area BS	BC1	F_{UL_low} to F_{UL_high}	-96 dBm	100 kHz	
Wide Area BS	BC2	F_{UL_low} to F_{UL_high}	-98 dBm	100 kHz	
Medium Range BS	BC1, BC2	F_{UL_low} to F_{UL_high}	-91 dBm	100 kHz	
Local Area BS	BC1, BC2	F_{UL_low} to F_{UL_high}	-88 dBm	100 kHz	
NOTE: F_{UL_low} and F_{UL_high} are the lowest and highest frequency of the BS uplink operating band respectively.					

4.2.4.3 Conformance

Conformance tests described in clause 5.3.3 shall be carried out.

4.2.5 Base station maximum output power

4.2.5.1 Definition

Output power of the Base Station is the mean power delivered to a load with resistance equal to the nominal load impedance of the transmitter.

The configured carrier power is the target maximum power for a specific carrier for the operating mode set in the BS within the limits given by the manufacturer's declaration.

The maximum carrier output power, $P_{\max,c}$ of the Base Station is the mean power level measured at the antenna connector during the transmitter ON period for a specific carrier in a specified reference condition.

4.2.5.2 Limits

In normal conditions, the maximum carrier output power shall for UTRA and E-UTRA remain:

- within +2,7 dB and -2,7 dB of the manufacturer's rated carrier output power for carrier frequency $f \leq 3,0$ GHz,
- within +3,0 dB and -3,0 dB of the manufacturer's rated output power for carrier frequency $3,0 \text{ GHz} < f \leq 4,2 \text{ GHz}$,

and for GSM/EDGE remain within +3,0 dB and -3,0 dB of the manufacturer's rated carrier output power.

In extreme conditions, maximum carrier output power shall for UTRA and E-UTRA remain:

- within +3,2 dB and -3,2 dB of the manufacturer's rated carrier output power for carrier frequency $f \leq 3,0$ GHz,
- within +3,5 dB and -3,5 dB of the manufacturer's rated output power for carrier frequency $3,0 \text{ GHz} < f \leq 4,2 \text{ GHz}$,

and for GSM/EDGE remain within +3,5 dB and -3,5 dB of the manufacturer's rated carrier output power.

4.2.5.3 Conformance

Conformance tests described in clause 5.3.4 shall be carried out.

4.2.6 Transmit intermodulation

4.2.6.1 Definition

The transmitter intermodulation requirement is a measure of the capability of the transmitter to inhibit the generation of signals in its nonlinear elements caused by presence of the wanted signal and an interfering signal reaching the transmitter via the antenna. The requirement shall apply during the transmitter ON period and the transmitter transient period.

The transmitter intermodulation level is the power of the intermodulation products when an interfering signal is injected into the antenna connector.

For BS capable of multi-band operation where multiple bands are mapped on separate antenna connectors, the single-band requirements shall apply regardless of the interfering signals position relative to the Inter RF bandwidth gap.

4.2.6.2 Limits

4.2.6.2.1 General limits

In the frequency range relevant for this test, the transmitter intermodulation level shall not exceed the unwanted emission limits in clauses 4.2.2.2, 4.2.3.2 and 4.2.4.2 in the presence of a wanted signal and an interfering signal according to table 4.2.6.2.1-1 for BS operation in BC1, BC2 and BC3. The measurement may be limited to frequencies on which third and fifth order intermodulation products appear, considering the width of these products and excluding the bandwidths of the wanted and interfering signals.

The requirement shall apply outside the Base Station RF bandwidth or Maximum Radio Bandwidth. The interfering signal offset is defined relative to the Base Station RF bandwidth edges or Maximum Radio Bandwidth edges.

For BS operating in non-contiguous spectrum, the requirement is also applicable inside a sub-block gap for interfering signal offsets where the interfering signal falls completely within the sub-block gap. The interfering signal offset is defined relative to the sub-block edges.

For BS capable of multi-band operation, the requirement shall apply relative to the Base Station RF bandwidth edges of each operating band. In case the Inter RF bandwidth gap is less than 15 MHz, the requirement in the gap shall apply only for interfering signal offsets where the interfering signal falls completely within the Inter RF bandwidth gap.

Table 4.2.6.2.1-1: Interfering signals for the Transmitter intermodulation requirement

Parameter	Value
Interfering signal type	E-UTRA signal of channel bandwidth 5 MHz
Interfering signal level	Mean power level 30 dB below the mean power of the wanted signal
Interfering signal centre frequency offset from edge of the Base Station RF bandwidth	2,5 MHz for modulated interferer 7,5 MHz for modulated interferer 12,5 MHz for modulated interferer
NOTE:	Interfering signal positions that are partially or completely outside of the downlink operating band of the Base Station are excluded from the requirement, unless the interfering signal positions fall within the frequency range of adjacent downlink operating bands in the same geographical area. In case that none of the interfering signal positions fall completely within the frequency range of the downlink operating band, the test suite in clause 5.3.5 provides further guidance.

4.2.6.2.2 Additional limits (BC1 and BC2)

In the frequency range relevant for this test, the transmitter intermodulation level shall not exceed the unwanted emission limits in clauses 4.2.2.2, 4.2.3.2 and 4.2.4.2 in the presence of a wanted signal and an interfering signal according to table 4.2.6.2.2-1 for BS operation in BC2. The measurement may be limited to frequencies on which third and fifth order intermodulation products appear, considering the width of these products and excluding the bandwidths of the wanted and interfering signals.

The requirement shall apply outside of the Base Station RF bandwidth or Maximum Radio Bandwidth for BC2. The interfering signal offset is defined relative to the Base Station RF bandwidth edges or Maximum Radio Bandwidth edges.

For BS operating in non-contiguous spectrum in BC1 or BC2, the requirement is also applicable inside a sub-block gap larger than or equal to two times the interfering signal centre frequency offset. For BS operating in non-contiguous spectrum in BC1, the requirement is not applicable inside a sub-block gap with a gap size equal or larger than 5 MHz. The interfering signal offset is defined relative to the sub-block edges.

For BS capable of multi-band operation, the requirement shall apply relative to the Base Station RF bandwidth edges of a BC2 operating band. The requirement is also applicable for BC1 and BC2 inside an Inter RF bandwidth gap equal to or larger than two times the interfering signal centre frequency offset. For BS capable of multi-band operation, the requirement is not applicable for BC1 band inside an Inter RF bandwidth gap with a gap size equal to or larger than 5 MHz.

Table 4.2.6.2.2-1: Interfering signal for the Transmitter intermodulation requirement (BC2)

Parameter	Value
Interfering signal type	CW
Interfering signal level	Mean power level 30 dB below the mean power of the wanted signal
Interfering signal centre frequency offset from edge of the Base Station RF bandwidth	> 800 kHz for CW interferer
NOTE:	Interfering signal positions that are partially or completely outside of the downlink operating band of the Base Station are excluded from the requirement.

4.2.6.2.3 Additional limits (BC3)

In the frequency range relevant for this test, the transmitter intermodulation level shall not exceed the unwanted emission limits in clauses 4.2.2.2, 4.2.3.2 and 4.2.4.2 in the presence of a wanted signal and an interfering signal according to table 4.2.6.2.3-1 for BS operation in BC3. The measurement may be limited to frequencies on which third and fifth order intermodulation products appear, considering the width of these products and excluding the bandwidths of the wanted and interfering signals.

For BS capable of multi-band operation, the requirement shall apply relative to the Base Station RF bandwidth edges of each operating band. In case the Inter RF bandwidth gap is less than 3,2 MHz, the requirement in the gap shall apply only for interfering signal offsets where the interfering signal falls completely within the Inter RF bandwidth gap.

Table 4.2.6.2.3-1: Interfering signals for the Transmitter intermodulation requirement (BC3)

Parameter	Value
Interfering signal type	1,28 Mcps UTRA TDD signal of channel bandwidth 1,6 MHz
Interfering signal level	Mean power level 30 dB below the mean power of the wanted signal
Interfering signal centre frequency offset from edge of the Base Station RF bandwidth	0,8 MHz for modulated 1,28 Mcps TDD interferer 1,6 MHz for modulated 1,28 Mcps TDD interferer 2,4 MHz for modulated 1,28 Mcps TDD interferer
NOTE:	Interfering signal positions that are partially or completely outside of the downlink operating band of the Base Station are excluded from the requirement.

4.2.6.3 Conformance

Conformance tests described in clause 5.3.5 shall be carried out.

4.2.7 Receiver spurious emissions

4.2.7.1 Definition

The receiver spurious emissions power is the power of emissions generated or amplified in a receiver that appear at the BS receiver antenna connector. The requirements shall apply to all BS with separate RX and TX antenna ports. In this case for FDD BS the test shall be performed when both TX and RX are on, with the TX port terminated.

For TDD BS with common RX and TX antenna port the requirement shall apply during the Transmitter OFF period. For FDD BS with common RX and TX antenna port the transmitter spurious emission limits as specified in clause 4.2.4 are valid.

For BS capable of multi-band operation where multiple bands are mapped on separate antenna connectors, the single-band requirements shall apply and the excluded frequency range is only applicable for the operating band supported on each antenna connector.

4.2.7.2 Limits

4.2.7.2.1 General limits

The power of any spurious emission shall not exceed the levels in table 4.2.7.2.1-1.

In addition to the requirements in table 4.2.7.2.1-1, the power of any spurious emission shall not exceed the limits specified in clauses 4.2.4.2.3 and 4.2.4.2.4.

Table 4.2.7.2.1-1: General spurious emission test requirement

Frequency range	Maximum level	Measurement Bandwidth	Note
30 MHz to 1 GHz	-57 dBm	100 kHz	
1 GHz to 12,75 GHz	-47 dBm	1 MHz	
12,75 GHz to 5 th harmonic of the upper frequency edge of the downlink operating band	-47 dBm	1 MHz	Shall apply only for Bands 22, 42 and 43.
NOTE: The frequency range from $F_{\text{BW RF,DL,low}} - 10 \text{ MHz}$ to $F_{\text{BW RF,DL,high}} + 10 \text{ MHz}$ may be excluded from the requirement. For BS capable of multi-band operation, the exclusion shall apply for all supported operating bands. For BS capable of multi-band operation where multiple bands are mapped on separate antenna connectors, the single-band requirements shall apply and the excluded frequency range is only applicable for the operating band supported on each antenna connector.			

4.2.7.2.2 Additional limits for BC2

For a BS operating in Band Category 2 when GSM/EDGE is configured, the power of any spurious emissions shall not exceed the limits in table 4.2.7.2.2-1.

For BS capable of multi-band operation, the limits in table 4.2.7.2.2-1 are only applicable when all supported operating bands belong to BC2 and GSM/EDGE is configured in all bands.

Table 4.2.7.2.2-1: Additional BS spurious emissions limits for BC2, Category B

Frequency range	Frequency offset from transmitter operating band edge (see note)	Maximum level	Measurement Bandwidth
500 MHz to 1 GHz	10 MHz to 20 MHz	-57 dBm	300 kHz
	20 MHz to 30 MHz	-57 dBm	1 MHz
	$\geq 30 \text{ MHz}$	-57 dBm	3 MHz
1 GHz to 12,75 GHz	$\geq 30 \text{ MHz}$	-47 dBm	3 MHz
NOTE: For BS capable of multi-band operation, the frequency offset is relative to the closest supported operating band.			

4.2.7.3 Conformance

Conformance tests described in clause 5.3.6 shall be carried out.

4.2.8 In-band blocking

4.2.8.1 Definition

The in-band blocking characteristics is a measure of the receiver ability to receive a wanted signal at its assigned channel in the presence of an unwanted interferer inside the operating band.

4.2.8.2 Limits

4.2.8.2.1 General limits

For the general blocking requirement, the interfering signal shall be a UTRA FDD signal as specified in clause A.1 of ETSI TS 137 141 [1].

The requirement shall apply outside of the Base Station RF bandwidth or Maximum Radio Bandwidth. The interfering signal offset is defined relative to the Base Station RF bandwidth edges or Maximum Radio Bandwidth edges.

For BS operating in non-contiguous spectrum, the requirement shall apply in addition inside any sub-block gap, in case the sub-block gap size is at least 15 MHz. The interfering signal offset is defined relative to the sub-block edges inside the sub-block gap.

For BS capable of multi-band operation, the requirement shall apply in addition inside any Inter RF bandwidth gap, in case the gap size is at least 15 MHz. The interfering signal offset is defined relative to the Base Station RF bandwidth edges inside the Inter RF bandwidth gap.

For the wanted and interfering signal coupled to the Base Station antenna input, using the parameters in tables 4.2.8.2.1-1 and 4.2.8.2.1-2, the following requirements shall be met:

- For any measured E-UTRA carrier, the throughput shall be ≥ 95 % of the maximum throughput of the reference measurement channel defined in ETSI TS 136 104 [4], clause 7.2.
- For any measured UTRA FDD carrier, the BER shall not exceed 0,001 for the reference measurement channel defined in ETSI TS 125 104 [2], clause 7.2.
- For any measured UTRA TDD carrier, the BER shall not exceed 0,001 for the reference measurement channel defined in ETSI TS 125 105 [3], clause 7.2.
- For any measured GSM/EDGE carrier, the conditions are specified in ETSI TS 145 005 [5], clause P.2.1.

For BS capable of multi-band operation, the requirement shall apply according to table 4.2.8.2.1-1 for the in-band blocking frequency ranges of each supported operating band.

Table 4.2.8.2.1-1: General blocking requirement

Base Station Type	Mean power of interfering signal [dBm]	Wanted Signal mean power [dBm] (see note 1)	Centre Frequency of Interfering Signal	Interfering signal centre frequency minimum frequency offset from the Base Station RF bandwidth edge or edge of sub-block inside a gap [MHz]
Wide Area BS	-40	$P_{\text{REFSENS}} + x$ dB (see note 2)	See table 4.2.8.2.1-2	$\pm 7,5$
Medium Range BS	-35	$P_{\text{REFSENS}} + x$ dB (see note 3)		
Local Area BS	-30	$P_{\text{REFSENS}} + x$ dB (see note 4)		
NOTE 1: P_{REFSENS} depends on the RAT, the BS class and on the channel bandwidth, see clause 7.2 in ETSI TS 137 141 [1].				
NOTE 2: For WA BS, "x" is equal to 6 in case of E-UTRA or UTRA wanted signals and equal to 3 in case of GSM/EDGE wanted signal.				
NOTE 3: For MR BS, "x" is equal to 6 in case of UTRA wanted signals, 9 in case of E-UTRA wanted signal and 3 in case of GSM/EDGE wanted signal.				
NOTE 4: For LA BS, "x" is equal to 11 in case of E-UTRA wanted signal, 6 in case of UTRA wanted signal and equal to 3 in case of GSM/EDGE wanted signal.				
NOTE 5: For a BS capable of multi-band operation, "x" in notes 2, 3, 4 shall apply in case of interfering signals that are in the in-band blocking frequency range of the operating band where the wanted signal is present. For other in-band blocking frequency ranges of the interfering signal for the supported operating bands, "x" is equal to 1,4 dB.				

Table 4.2.8.2.1-2: Interfering signal for the general blocking requirement

Operating Band Number	Centre Frequency of Interfering Signal [MHz]
1, 3, 7, 22, 33, 34, 38, 40, 42, 43	$(F_{\text{UL_low}} - 20)$ to $(F_{\text{UL_high}} + 20)$
8	$(F_{\text{UL_low}} - 20)$ to $(F_{\text{UL_high}} + 10)$
20	$(F_{\text{UL_low}} - 11)$ to $(F_{\text{UL_high}} + 20)$

4.2.8.2.2 Additional BC3 blocking limits

The interfering signal is a 1,28 Mcps UTRA TDD modulated signal as specified in clause A.2 of ETSI TS 137 141 [1].

The requirement shall apply outside the Base Station RF bandwidth or Maximum Radio Bandwidth. The interfering signal offset is defined relative to the Base Station RF bandwidth edges or Maximum Radio Bandwidth edges.

For BS capable of multi-band operation, the requirement shall apply in addition inside any Inter RF bandwidth gap, in case the gap size is at least 4,8 MHz. The interfering signal offset is defined relative to the Base Station RF bandwidth edges inside the Inter RF bandwidth gap.

For the wanted and interfering signal coupled to the Base Station antenna input, using the parameters in table 4.2.8.2.2-1, the following requirements shall be met:

- For any measured E-UTRA TDD carrier, the throughput shall be ≥ 95 % of the maximum throughput of the reference measurement channel defined in ETSI TS 136 104 [4], clause 7.2.
- For any measured UTRA TDD carrier, the BER shall not exceed 0,001 for the reference measurement channel defined in ETSI TS 125 105 [3], clause 7.2.

Table 4.2.8.2.2-1: Additional blocking requirement for Band Category 3

Operating Band	Centre Frequency of Interfering Signal [MHz]	Interfering Signal mean power [dBm]	Wanted Signal mean power [dBm]	Interfering signal centre frequency minimum frequency offset from the Base Station RF bandwidth edge or edge of sub-block inside a gap [MHz]
33, 34, 38, 40	$(F_{UL_low} - 20)$ to $(F_{UL_high} + 20)$	-40	$P_{REFSENS} + 6$ dB (see note)	$\pm 2,4$
NOTE: $P_{REFSENS}$ depends on the RAT and on the channel bandwidth, see clause 7.2 of ETSI TS 137 141 [1].				

4.2.8.3 Conformance

Conformance tests described in clause 5.3.7 shall be carried out.

4.2.9 Out-of-band blocking

4.2.9.1 Definition

The Out-of-band blocking characteristic is a measure of the receiver ability to receive a wanted signal at its assigned channel in the presence of an unwanted interferer outside the uplink operating band.

4.2.9.2 Limits

The interfering signal shall be a CW carrier.

For a wanted and an interfering signal coupled to BS antenna input using the parameters in table 4.2.9.2-1, the following requirements shall be met:

- For any measured E-UTRA carrier, the throughput shall be ≥ 95 % of the maximum throughput of the reference measurement channel defined in ETSI TS 136 104 [4], clause 7.2.
- For any measured UTRA FDD carrier, the BER shall not exceed 0,001 for the reference measurement channel defined in ETSI TS 125 104 [2], clause 7.2.
- For any measured UTRA TDD carrier, the BER shall not exceed 0,001 for the reference measurement channel defined in ETSI TS 125 105 [3], clause 7.2.
- For any measured GSM/EDGE carrier, the conditions are specified in ETSI TS 145 005 [5], clause P.2.1.

For BS capable of multi-band operation, the requirements above shall apply for each supported operating band. The in-band blocking frequency ranges of all supported operating bands according to table 4.2.8.2.1-2 shall be excluded from the requirements.

Table 4.2.9.2-1: Blocking performance requirement

Operating Band Number	Centre Frequency of Interfering Signal [MHz]	Interfering Signal mean power [dBm]	Wanted Signal mean power [dBm]	Type of Interfering Signal
1, 3, 7, 22, 33, 34, 38, 40, 42, 43	1 to $(F_{UL_low} - 20)$ $(F_{UL_high} + 20)$ to 12 750	-15	$P_{REFSENS} + x$ dB (see note)	CW carrier
8, 28	1 to $(F_{UL_low} - 20)$ $(F_{UL_high} + 10)$ to 12 750	-15	$P_{REFSENS} + x$ dB (see note)	CW carrier
20	1 to $(F_{UL_low} - 11)$ $(F_{UL_high} + 20)$ to 12 750	-15	$P_{REFSENS} + x$ dB (see note)	CW carrier
NOTE: $P_{REFSENS}$ depends on the RAT, the BS class and the channel bandwidth, see clause 7.2 of ETSI TS 137 141 [1]. "x" is equal to 6 in case of E-UTRA or UTRA wanted signals and equal to 3 in case of GSM/EDGE wanted signal.				

4.2.9.3 Conformance

Conformance tests described in clause 5.3.8 shall be carried out.

4.2.10 Receiver intermodulation characteristics

4.2.10.1 Definition

Third and higher order mixing of the two interfering RF signals can produce an interfering signal in the band of the desired channel. Intermodulation response rejection is a measure of the capability of the receiver to receive a wanted signal on its assigned channel frequency in the presence of two interfering signals which have a specific frequency relationship to the wanted signal.

4.2.10.2 Limits

4.2.10.2.1 General intermodulation limits

Interfering signals shall be a CW signal and an E-UTRA or UTRA signal, as specified in annex A of ETSI TS 137 141 [1].

The requirement shall apply outside the Base Station RF bandwidth or Maximum Radio Bandwidth. The interfering signal offset is defined relative to the Base Station RF bandwidth edges or Maximum Radio Bandwidth edges.

For BS capable of multi-band operation, the requirement shall apply in addition inside any Inter RF bandwidth gap, in case the gap size is at least twice as wide as the UTRA/E-UTRA interfering signal centre frequency offset from the Base Station RF bandwidth edge. The interfering signal offset is defined relative to the Base Station RF bandwidth edges inside the Inter RF bandwidth gap.

For the wanted signal at the assigned channel frequency and two interfering signals coupled to the Base Station antenna input, using the parameters in tables 4.2.10.2.1-1 and 4.2.10.2.1-2, the following requirements shall be met:

- For any measured E-UTRA carrier, the throughput shall be ≥ 95 % of the maximum throughput of the reference measurement channel defined in ETSI TS 136 104 [4], clause 7.2.
- For any measured UTRA FDD carrier, the BER shall not exceed 0,001 for the reference measurement channel defined in ETSI TS 125 104 [2], clause 7.2.
- For any measured UTRA TDD carrier, the BER shall not exceed 0,001 for the reference measurement channel defined in ETSI TS 125 105 [3], clause 7.2.

- For any measured GSM/EDGE carrier, the conditions are specified in ETSI TS 145 005 [5], clause P.2.2.

Table 4.2.10.2.1-1: General intermodulation requirement

Base Station Type	Mean power of interfering signals [dBm]	Wanted Signal mean power [dBm] (see notes)	Type of interfering signal
Wide Area BS	-48	$P_{\text{REFSENS}} + x \text{ dB}$	See table 4.2.10.2.1-2
Medium Range BS	-44	$P_{\text{REFSENS}} + x \text{ dB}$	
Local Area BS	-38	$P_{\text{REFSENS}} + x \text{ dB}$	
NOTE 1: P_{REFSENS} depends on the RAT, the BS class and on the channel bandwidth, see clause 7.2 in ETSI TS 137 141 [1]. For E-UTRA channel bandwidths 10, 15 and 20 MHz this requirement shall apply only for a FRC A1-3 mapped to the frequency range at the channel edge adjacent to the interfering signals.			
NOTE 2: For WA BS, "x" is equal to 6 in case of E-UTRA or UTRA wanted signals and equal to 3 in case of GSM/EDGE wanted signal.			
NOTE 3: For MR BS, "x" is equal to 6 in case of UTRA wanted signals, 9 in case of E-UTRA wanted signal and equal to 3 in case of GSM/EDGE wanted signal.			
NOTE 4: For LA BS, "x" is equal to 12 in case of E-UTRA wanted signals, 6 in case of UTRA wanted signal and equal to 3 in case of GSM/EDGE wanted signal.			

Table 4.2.10.2.1-2: Interfering signals for intermodulation requirement

RAT of the carrier adjacent to the high/low edge of the Base Station RF bandwidth	Interfering signal centre frequency offset from the Base Station RF bandwidth edge [MHz]	Type of interfering signal
E-UTRA 1,4 MHz	$\pm 2,0$ (BC1 and BC3) / $\pm 2,1$ (BC2)	CW
	$\pm 4,9$	1,4 MHz E-UTRA signal
E-UTRA 3 MHz	$\pm 4,4$ (BC1 and BC3) / $\pm 4,5$ (BC2)	CW
	$\pm 10,5$	3 MHz E-UTRA signal
UTRA FDD and E-UTRA 5 MHz	$\pm 7,5$	CW
	$\pm 17,5$	5 MHz E-UTRA signal
E-UTRA 10 MHz	$\pm 7,375$	CW
	$\pm 17,5$	5 MHz E-UTRA signal
E-UTRA 15 MHz	$\pm 7,25$	CW
	$\pm 17,5$	5 MHz E-UTRA signal
E-UTRA 20 MHz	$\pm 7,125$	CW
	$\pm 17,5$	5 MHz E-UTRA signal
GSM/EDGE	$\pm 7,575$	CW
	$\pm 17,5$	5 MHz E-UTRA signal
1,28 Mcps UTRA TDD	$\pm 2,3$ (BC3)	CW
	$\pm 5,6$ (BC3)	1,28 Mcps UTRA TDD signal

4.2.10.2.2 General narrowband intermodulation limits

Interfering signals shall be a CW signal and an E-UTRA 1RB signal, as specified in annex A of ETSI TS 137 141 [1].

The requirement shall apply outside the Base Station RF bandwidth or Maximum Radio Bandwidth. The interfering signal offset is defined relative to the Base Station RF bandwidth edges or Maximum Radio Bandwidth edges.

For BS operating in non-contiguous spectrum within each supported operating band, the requirement shall apply in addition inside any sub-block gap in case the sub-block gap is at least as wide as the channel bandwidth of the E-UTRA interfering signal in table 4.2.10.2.2-2. The interfering signal offset is defined relative to the sub-block edges inside the gap.

For BS capable of multi-band operation, the requirement shall apply in addition inside any Inter RF bandwidth gap in case the gap size is at least as wide as the E-UTRA interfering signal in table 7.7.5.2-2. The interfering signal offset is defined relative to the Base Station RF bandwidth edges inside the Inter RF bandwidth gap.

For the wanted signal at the assigned channel frequency and two interfering signals coupled to the Base Station antenna input, using the parameters in tables 4.2.10.2.2-1 and 4.2.10.2.2-2, the following requirements shall be met:

- For any measured E-UTRA carrier, the throughput shall be ≥ 95 % of the maximum throughput of the reference measurement channel defined in ETSI TS 136 104 [4], clause 7.2.
- For any measured UTRA FDD carrier, the BER shall not exceed 0,001 for the reference measurement channel defined in ETSI TS 125 104 [2], clause 7.2.
- For any measured UTRA TDD carrier, the BER shall not exceed 0,001 for the reference measurement channel defined in ETSI TS 125 105 [3], clause 7.2.
- For any measured GSM/EDGE carrier, the conditions are specified in ETSI TS 145 005 [5], clause P.2.2.

Table 4.2.10.2.2-1: General narrowband intermodulation requirement

Base Station Type	Mean power of interfering signals [dBm]	Wanted Signal mean power [dBm]	Type of interfering signal
Wide Area BS	-52	$P_{\text{REFSENS}} + x$ dB (see note)	See table 7.7.5.2-2 in ETSI TS 137 141 [1]
Medium Range BS	-47		
Local Area BS	-44		
NOTE: P_{REFSENS} depends on the RAT, the BS class and on the channel bandwidth, see clause 7.2 in ETSI TS 137 141 [1]. "x" is equal to 6 in case of E-UTRA or UTRA wanted signals and equal to 3 in case of GSM/EDGE wanted signal.			

Table 4.2.10.2.2-2: Interfering signals for narrowband intermodulation requirement

RAT of the carrier adjacent to the high/low edge of the Base Station RF bandwidth or edge of the sub-block	Interfering signal centre frequency offset from the Base Station RF bandwidth edge or edge of sub-block inside a gap [kHz]	Type of interfering signal
E-UTRA 1,4 MHz	± 260 (BC1 and BC3) / ± 270 (BC2)	CW
	± 970 (BC1 and BC3) / ± 790 (BC2)	1,4 MHz E-UTRA signal, 1 RB (see note 1)
E-UTRA 3 MHz	± 260 (BC1 and BC3) / ± 270 (BC2)	CW
	± 960 (BC1 and BC3) / ± 780 (BC2)	3,0 MHz E-UTRA signal, 1 RB (see note 1)
E-UTRA 5 MHz	± 360	CW
	$\pm 1\ 060$	5 MHz E-UTRA signal, 1 RB (see note 1)
E-UTRA 10 MHz (see note 2)	± 325	CW
	$\pm 1\ 240$	5 MHz E-UTRA signal, 1 RB (see note 1)
E-UTRA 15 MHz (see note 2)	± 380	CW
	$\pm 1\ 600$	5 MHz E-UTRA signal, 1 RB (see note 1)
E-UTRA 20 MHz (see note 2)	± 345	CW
	$\pm 1\ 780$	5 MHz E-UTRA signal, 1 RB (see note 1)
UTRA FDD	± 345 (BC1 and BC2)	CW
	$\pm 1\ 780$ (BC1 and BC2)	5 MHz E-UTRA signal, 1 RB (see note 1)
GSM/EDGE	± 340	CW
	± 880	5 MHz E-UTRA signal, 1 RB (see note 1)
1,28 Mcps UTRA TDD	± 190 (BC3)	CW
	± 970 (BC3)	1,4 MHz E-UTRA signal, 1 RB (see note 1)
NOTE 1: Interfering signal consisting of one resource block positioned at the stated offset, the channel bandwidth of the interfering signal is located adjacently to the Base Station RF bandwidth edge or edge of sub-block inside a gap.		
NOTE 2: This requirement shall apply only for an E-UTRA FRC A1-3 mapped to the frequency range at the channel edge adjacent to the interfering signals.		

4.2.10.2.3 Additional narrowband intermodulation limits for GSM/EDGE

The GSM/EDGE MC-BTS receiver intermodulation test requirements stated in ETSI EN 301 502 [9], applicable parts of clause 4.2.13, shall apply for GSM/EDGE carriers.

The conditions specified in ETSI TS 145 005 [5], clause P.2.2 shall apply for the GSM/EDGE intermodulation requirement.

4.2.10.3 Conformance

Conformance tests described in clause 5.3.9 shall be carried out.

4.2.11 Narrowband blocking

4.2.11.1 Definition

The narrowband blocking characteristics is a measure of the receiver ability to receive a wanted signal at its assigned channel in the presence of an unwanted interferer inside the operating band in the adjacent channel.

4.2.11.2 Limits

4.2.11.2.1 General limits

For the narrowband blocking requirement, the interfering signal shall be an E-UTRA 1RB signal as specified in clause A.3 of ETSI TS 137 141 [1].

The requirement shall apply outside of the Base Station RF bandwidth or Maximum Radio Bandwidth. The interfering signal offset is defined relative to the Base Station RF bandwidth edges or Maximum Radio Bandwidth edges.

For BS operating in non-contiguous spectrum, the requirement shall apply in addition inside any sub-block gap, in case the sub-block gap size is at least 3 MHz. The interfering signal offset is defined relative to the sub-block edges inside the sub-block gap.

For BS capable of multi-band operation, the requirement shall apply in addition inside any Inter RF bandwidth gap in case the gap size is at least 3 MHz. The interfering signal offset is defined relative to the Base Station RF bandwidth edges inside the Inter RF bandwidth gap.

For the wanted and interfering signal coupled to the Base Station antenna input, using the parameters in table 4.2.11.2.1-1 the following requirements shall be met:

- For any measured E-UTRA carrier, the throughput shall be ≥ 95 % of the maximum throughput of the reference measurement channel defined in ETSI TS 136 104 [4], clause 7.2.
- For any measured UTRA FDD carrier, the BER shall not exceed 0,001 for the reference measurement channel defined in ETSI TS 125 104 [2], clause 7.2.
- For any measured UTRA TDD carrier, the BER shall not exceed 0,001 for the reference measurement channel defined in ETSI TS 125 105 [3], clause 7.2.
- For any measured GSM/EDGE carrier, the conditions are specified in ETSI TS 145 005 [5], clause P.2.1.

Table 4.2.11.2.1-1: Narrowband blocking requirement

Base Station Type	RAT of the carrier	Wanted signal mean power [dBm]	Interfering signal mean power [dBm]	Interfering RB (see note 2) centre frequency offset from the Base Station RF bandwidth edge or edge of sub-block inside a gap [kHz]
Wide Area BS	E-UTRA, UTRA and GSM/EDGE	$P_{\text{REFSENS}} + x$ dB (see note 1)	-49	$\pm(240 + m \times 180)$, $m=0, 1, 2, 3, 4, 9, 14$
Medium Range BS			-44	
Local Area BS			-41	
NOTE 1: P_{REFSENS} depends on the RAT, the BS class and on the channel bandwidth, see clause 7.2 in ETSI TS 137 141 [1]. "x" is equal to 6 in case of E-UTRA or UTRA wanted signals and equal to 3 in case of GSM/EDGE wanted signal.				
NOTE 2: Interfering signal (E-UTRA 3 MHz) consisting of one resource block positioned at the stated offset, the channel bandwidth of the interfering signal is located adjacently to the Base Station RF bandwidth edge.				

4.2.11.2.2 Additional limits for GSM/EDGE

The GSM/EDGE in-band blocking test requirements are stated in ETSI EN 301 502 [9], applicable parts of clause 4.2.12.

The conditions specified in ETSI TS 145 005 [5], clause P.2.1 shall apply for GSM/EDGE in-band narrowband blocking.

4.2.11.2.3 GSM/EDGE limits for AM suppression

The GSM/EDGE in-band blocking test requirements are stated in ETSI EN 301 502 [9], applicable parts of clause 4.2.14.

The conditions specified in ETSI TS 145 005 [5], clause P.2.3 shall apply for GSM/EDGE AM suppression.

4.2.11.3 Conformance

Conformance tests described in clause 5.3.10 shall be carried out.

4.2.12 Reference sensitivity level

4.2.12.1 Definition

The reference sensitivity power level P_{REFSENS} is the minimum mean power received at the antenna connector at which a reference performance requirement shall be met for a specified reference measurement channel.

The reference sensitivity level requirement is defined separately for each RAT. Additional details are in ETSI EN 301 908-14 [7], clause 4.2.14, ETSI EN 301 908-3 [6], clause 4.2.12, ETSI TS 125 142 [13], clause 7.2 and ETSI EN 301 502 [9], clause 4.2.9.

4.2.12.2 Limits

For E-UTRA the test requirement is in ETSI EN 301 908-14 [7], clause 4.2.14.2.

For UTRA-FDD the test requirement is in ETSI EN 301 908-3 [6], clause 4.2.12.2.

For UTRA-TDD the test requirement is in ETSI TS 125 142 [13], clause 7.2.2.

For GSM-EDGE the test requirement is in ETSI EN 301 502 [9], clause 4.2.9.2.

4.2.12.3 Conformance

Conformance tests described in clause 5.3.11 shall be carried out.

5 Testing for compliance with technical requirements

5.1 Environmental conditions for testing

Tests defined in the present document shall be carried out at representative points within the boundary limits of the declared operational environmental profile.

Where technical performance varies subject to environmental conditions, tests shall be carried out under a sufficient variety of environmental conditions (within the boundary limits of the declared operational environmental profile) to give confidence of compliance for the affected technical requirements.

Normally it should be sufficient for all tests to be conducted using normal test conditions except where otherwise stated. For guidance on the use of other test conditions to be used in order to show compliance reference can be made to ETSI TS 137 141 [1], annex B.

5.2 Interpretation of the measurement results

The interpretation of the results recorded in a test report for the measurements described in the present document shall be as follows:

- the measured value related to the corresponding limit will be used to decide whether an equipment meets the requirements of the present document;
- the value of the measurement uncertainty for the measurement of each parameter shall be included in the test report;
- the recorded value of the measurement uncertainty shall be, for each measurement, equal to or lower than the figures in table 5.2-1.

For the test methods, according to the present document, the measurement uncertainty figures shall be calculated and shall correspond to an expansion factor (coverage factor) $k = 1,96$ (which provides a confidence level of 95 % in the case where the distributions characterizing the actual measurement uncertainties are normal (Gaussian)). Principles for the calculation of measurement uncertainty are contained in ETSI TR 100 028 [i.3], in particular in annex D of the ETSI TR 100 028-2 [i.3].

Table 5.2-1 is based on such expansion factors.

Table 5.2-1: Maximum measurement uncertainty

Parameter	Condition	Uncertainty
Operating band unwanted emissions	General limits $f \leq 3,0$ GHz $3,0$ GHz < $f \leq 4,2$ GHz Limits for GSM/EDGE single-RAT operation Limits for protection of DTT	$\pm 1,5$ dB $\pm 1,8$ dB (see note 5) $\pm 1,5$ dB
Adjacent Channel Leakage power Ratio (ACLR)	(see note 4)	(see note 4)
Cumulative Adjacent Channel Leakage power Ratio (CACLR)	CACLR CACLR absolute power $f \leq 3,0$ GHz $3,0$ GHz < $f \leq 4,2$ GHz	$\pm 0,8$ dB $\pm 2,0$ dB $\pm 2,5$ dB
Transmitter spurious emissions	For "Spurious emissions" and "Additional spurious emissions requirement for BC2" 9 kHz < $f \leq 4$ GHz 4 GHz < $f \leq 19$ GHz For co-existence requirements (> -60 dBm) For co-existence requirements (\leq -60 dBm)	$\pm 2,0$ dB $\pm 4,0$ dB $\pm 2,0$ dB $\pm 3,0$ dB

Parameter	Condition	Uncertainty
	For protection of the BS receiver	$\pm 3,0$ dB
Base station maximum output power	For UTRA and E-UTRA $f \leq 3,0$ GHz $3,0$ GHz $< f \leq 4,2$ GHz For GSM/EDGE	$\pm 0,7$ dB $\pm 1,0$ dB $\pm 1,0$ dB
Transmit intermodulation	For Operating band unwanted emissions For ACLR For "Spurious emissions" and "Additional spurious emissions requirement for BC2": $f \leq 2,2$ GHz $2,2$ GHz $< f \leq 4$ GHz $f > 4$ GHz For co-existence requirements Interference signal	$\pm 2,5$ dB $\pm 2,2$ dB $\pm 2,5$ dB $\pm 2,8$ dB $\pm 4,5$ dB $\pm 2,8$ dB $\pm 1,0$ dB
Receiver spurious emissions	30 MHz $\leq f \leq 4$ GHz 4 GHz $< f \leq 19$ GHz	$\pm 2,0$ dB $\pm 4,0$ dB
In-band blocking	$f \leq 3,0$ GHz $3,0$ GHz $< f \leq 4,2$ GHz	$\pm 1,4$ dB $\pm 1,8$ dB
Out-of-band blocking	1 MHz $< f_{\text{interferer}} \leq 3$ GHz 3 GHz $< f_{\text{interferer}} \leq 12,75$ GHz	$\pm 1,3$ dB $\pm 3,2$ dB
Receiver intermodulation characteristics	For general and narrowband intermodulation $f \leq 3,0$ GHz $3,0$ GHz $< f \leq 4,2$ GHz For "Additional narrowband intermodulation limits for GSM/EDGE"	$\pm 1,8$ dB $\pm 2,4$ dB (see note 5)
Narrowband blocking	For general limits $f \leq 3,0$ GHz $3,0$ GHz $< f \leq 4,2$ GHz For "Additional limits for GSM/EDGE" and "GSM/EDGE limits for AM suppression"	$\pm 1,4$ dB $\pm 1,8$ dB (see note 5)
Reference sensitivity level	UTRA and E-UTRA: $f \leq 3,0$ GHz $3,0$ GHz $< f \leq 4,2$ GHz GSM/EDGE	$\pm 0,7$ dB $\pm 1,0$ dB $\pm 1,0$ dB
<p>NOTE 1: For RF tests, it should be noted that the uncertainties in table 5.2-1 shall apply to the test system operating into a nominal 50 Ω load and do not include system effects due to mismatch between the EUT and the Test System.</p> <p>NOTE 2: Annex G of ETSI TR 100 028-2 [i.3] provides guidance for the calculation of the uncertainty components relating to mismatch.</p> <p>NOTE 3: If the test system for a test is known to have a measurement uncertainty greater than that specified in table 5.2-1, this equipment can still be used, provided that an adjustment is made as follows: any additional uncertainty in the test system over and above that specified in table 5.2-1 is used to tighten the test requirements - making the test harder to pass (for some tests, e.g. receiver tests, this may require modification of stimulus signals). This procedure will ensure that a test system not compliant with table 5.2-1 does not increase the probability of passing an EUT that would otherwise have failed a test if a test system compliant with table 5.2-1 had been used.</p> <p>NOTE 4: The maximum measurement uncertainty for ACLR is as defined in the referenced standards ETSI EN 301 908-3 [6], ETSI TS 125 142 [13] and ETSI EN 301 908-14 [7].</p> <p>NOTE 5: The maximum measurement uncertainty for GSM/EDGE single-RAT requirements included by reference is as defined in ETSI EN 301 502 [9].</p>		

5.3 Essential radio test suites

5.3.0 Introduction

This clause describes the test suites for MSR Base Stations.

The test configurations that shall be used for demonstrating conformance are specified in clause 5 of ETSI TS 137 141 [1]. Test configurations shall apply according to the declared RAT Capability Set (CS) of the Base Station and the Band Category of the declared operating band (BC1, BC2 or BC3). Transmitter test signals and test models as defined in clause 4.9.2 of ETSI TS 137 141 [1] shall be used.

Many tests in the present document are performed with the maximum Base Station RF bandwidth located at the bottom, middle and top of the supported frequency range in the operating band. These are denoted as B_{RFBW} (bottom), M_{RFBW} (middle) and T_{RFBW} (top) for single band testing and $B_{\text{RFBW}}-T'_{\text{RFBW}}$ and $B'_{\text{RFBW}}-T_{\text{RFBW}}$ for multi-band testing, and are defined in clause 4.9.1 of ETSI TS 137 141 [1].

The measurement system required for each test is presented for information in ETSI TS 137 141 [1], annex D.

5.3.1 Operating band unwanted emissions

5.3.1.0 General

For the operating band unwanted emissions requirement, where the tables with test configurations in clause 5 of ETSI TS 137 141 [1] refer to single-RAT specifications, the following shall apply:

- For references to "TS 25.141", the test suite specified in ETSI EN 301 908-3 [6], clauses 5.3.1.1 and 5.3.1.2 shall be used.
- For references to "TS 25.142", the test suite specified in ETSI TS 125 142 [13], clause 6.6.2.1.4 shall be used.
- For references to "TS 36.141", the test suite specified in ETSI EN 301 908-14 [7], clauses 5.3.1.1 and 5.3.1.2 shall be used.

The test requirements of the present document defined in clause 4.2.2 shall apply.

For GSM/EDGE single-RAT requirements for operating band unwanted emissions, the test suite is specified in ETSI EN 301 502 [9], applicable parts of clauses 5.3.4.1, 5.3.4.2, 5.3.5.2 and 5.3.8.

For operating band unwanted emissions requirements, where the tables with test configurations in clause 5 of ETSI TS 137 141 [1] refer to the MSR test configurations defined in clause 4.8 of ETSI TS 137 141 [1], the method of test described in clauses 5.3.1.1 and 5.3.1.2 shall apply.

5.3.1.1 Initial conditions

Test environment: normal; see clause B.2 of ETSI TS 137 141 [1].

Base Station RF bandwidth positions to be tested:

- B_{RFBW} , M_{RFBW} and T_{RFBW} in single-band operation; see clause 4.9.1 of ETSI TS 137 141 [1].
- $B_{\text{RFBW}}-T'_{\text{RFBW}}$ and $B'_{\text{RFBW}}-T_{\text{RFBW}}$ in multi-band operation, see clause 4.9.1 of ETSI TS 137 141 [1].

Test set-up:

- 1) Connect the signal analyser to the Base Station antenna connector as shown in clause D.1.1 of ETSI TS 137 141 [1].

As a general rule, the resolution bandwidth of the measuring equipment should be equal to the measurement bandwidth. However, to improve measurement accuracy, sensitivity, efficiency and to avoid e.g. carrier leakage, the resolution bandwidth may be smaller than the measurement bandwidth. When the resolution bandwidth is smaller than the measurement bandwidth, the result should be integrated over the measurement bandwidth in order to obtain the equivalent noise bandwidth of the measurement bandwidth.

- 2) Detection mode: True RMS.

5.3.1.2 Procedure

- 1) Set the Base Station to transmit at maximum power according to the applicable test configuration in clause 5 of ETSI TS 137 141 [1] using the corresponding test models or set of physical channels in clause 4.9.2 of ETSI TS 137 141 [1].
- 2) Step the centre frequency of the measurement filter in contiguous steps and measure the emission within the specified frequency ranges with the specified measurement bandwidth. For BS operating in multiple bands or non-contiguous spectrum, the emission within the Inter RF Bandwidth or sub-block gap shall be measured using the specified measurement bandwidth from the closest RF Bandwidth or sub block edge.
- 3) Repeat the test for the remaining test cases with channel set-up according to clauses 5 and 4.9.2 of ETSI TS 137 141 [1].

In addition, for a multi-band capable BS, the following step shall apply:

- 4) For multi-band capable BS and single band tests, repeat the steps above per involved band where single band test configurations and test models shall apply with no carrier activated in the other band. For multi-band capable BS with separate antenna connector, the antenna connector not being under test in case of SBT or MBT shall be terminated.

5.3.1.3 Test requirement

The results obtained shall be compared to the limits in clause 4.2.2.2 in order to prove compliance.

5.3.2 Adjacent Channel Leakage power Ratio (ACLR)

5.3.2.0 General

For the ACLR requirement, the tables with test configurations in clause 5 of ETSI TS 137 141 [1] also refer to single-RAT specifications. The following shall apply for references to single-RAT specifications:

- For references to "TS 25.141", the test suite specified in ETSI EN 301 908-3 [6], clauses 5.3.2.1 and 5.3.2.2 shall be used.
- For references to "TS 25.142", the test suite specified in ETSI TS 125 142 [13], clause 6.6.2.2.4 shall be used.
- For references to "TS 36.141", the test suite specified in ETSI EN 301 908-14 [7], clauses 5.3.2.1 and 5.3.2.2 shall be used.

The results obtained shall be compared to the limits in clause 4.2.3.2 in order to prove compliance.

For the ACLR requirement applied inside sub-block gap for non-contiguous spectrum operation or Inter RF bandwidth gap for multi-band operation using the test configurations defined in clause 4.8 of ETSI TS 137 141 [1], the method of test described in clauses 5.3.2.1 and 5.3.2.2 shall apply.

5.3.2.1 Initial conditions

Test environment: normal; see clause B.2 of ETSI TS 137 141 [1].

Base Station RF bandwidth positions to be tested:

- B_{RFBW} , M_{RFBW} and T_{RFBW} in single-band operation; see clause 4.9.1 of ETSI TS 137 141 [1].
- $B_{\text{RFBW-T}'_{\text{RFBW}}}$ and $B'_{\text{RFBW-T}}_{\text{RFBW}}$ in multi-band operation, see clause 4.9.1 of ETSI TS 137 141 [1].

Test set-up:

- 1) Connect the signal analyser to the Base Station antenna connector as shown in clause D.1.1 of ETSI TS 137 141 [1].

- 2) The measurement device characteristics shall be:
 - measurement filter bandwidth: defined in clause 4.2.3.2;
 - detection mode: true RMS voltage or true average power.

5.3.2.2 Procedure

- 1) Set the Base Station to transmit at maximum power according to the applicable test configuration in clause 5 of ETSI TS 137 141 [1] using the corresponding test models or set of physical channels in clause 4.9.2 of ETSI TS 137 141 [1].
- 2) For E-UTRA, measure ACLR inside sub-block gap or Inter RF bandwidth gap for an assumed 3,84 Mcps adjacent channel UTRA carrier as specified in clause 4.2.3.2.1.
- 3) For UTRA FDD, measure ACLR inside sub-block gap or Inter RF bandwidth gap as specified in clause 4.2.3.2.2.
- 4) Measure Cumulative Adjacent Channel Leakage power Ratio (CACLR) inside sub-block gap or the Inter RF bandwidth gap as specified in clause 4.2.3.2.4.

In addition, for a multi-band capable BS, the following step shall apply:

- 5) For multi-band capable BS and single band tests, repeat the steps above per involved band where single band test configurations and test models shall apply with no carrier activated in the other band. For multi-band capable BS with separate antenna connector, the antenna connector not being under test in case of SBT or MBT shall be terminated.

5.3.2.3 Test requirement

The results obtained shall be compared to the limits in clause 4.2.3.2.4 in order to prove compliance.

5.3.3 Transmitter spurious emissions

5.3.3.1 Initial conditions

Test environment: normal; see clause B.2 of ETSI TS 137 141 [1].

Base Station RF bandwidth position to be tested:

- B_{RFBW} , M_{RFBW} and T_{RFBW} single-band operation; see clause 4.9.1 of ETSI TS 137 141 [1].
- $B_{\text{RFBW}}-T_{\text{RFBW}}$ and $B'_{\text{RFBW}}-T_{\text{RFBW}}$ in multi-band operation, see clause 4.9.1 of ETSI TS 137 141 [1].

Test set-up:

- 1) Connect the BS antenna connector to a measurement receiver according to clause D.1.1 of ETSI TS 137 141 [1] using an attenuator or a directional coupler if necessary.
- 2) Measurements shall use a measurement bandwidth in accordance to the conditions in ETSI TS 137 104 [10], clause 6.6.1.
- 3) Detection mode: True RMS.

5.3.3.2 Procedure

- 1) Set the Base Station to transmit at maximum power according to the applicable test configuration in clause 5 of ETSI TS 137 141 [1] using the corresponding test models or set of physical channels in clause 4.9.2 of ETSI TS 137 141 [1].
- 2) Measure the emission at the specified frequencies with specified measurement bandwidth and note that the measured value does not exceed the specified value.

In addition, for a multi-band capable BS, the following step shall apply:

- 3) For multi-band capable BS and single band tests, repeat the steps above per involved band where single band test configurations and test models shall apply with no carrier activated in the other band. For multi-band capable BS with separate antenna connector, the antenna connector not being under test in case of SBT or MBT shall be terminated.

5.3.3.3 Test requirement

The results obtained shall be compared to the limits in clause 4.2.4.2 in order to prove compliance.

5.3.4 Base station maximum output power

5.3.4.1 Initial conditions

Test environment: normal; see clause B.2 of ETSI TS 137 141 [1].

Base Station RF bandwidth positions to be tested:

- B_{RFBW} , M_{RFBW} and T_{RFBW} in single-band operation; see clause 4.9.1 of ETSI TS 137 141 [1]
 $B_{\text{RFBW}}-T_{\text{RFBW}}$.
- $B'_{\text{RFBW}}-T_{\text{RFBW}}$ in multi-band operation, see clause 4.9.1 of ETSI TS 137 141 [1].

In addition, a single test shall be performed under extreme power supply conditions as defined in clause B.5 of ETSI TS 137 141 [1]. In this case, it is sufficient to test on a single combination of one ARFCN, UARFCN or E-ARFCN, one Base Station RF bandwidth position and with only one applicable test configuration defined in clause 5.

NOTE: Tests under extreme power supply also test extreme temperature, see ETSI TS 137 141 [1], clause B.3.1.

Connect the power measuring equipment to the MSR Base Station antenna connector as shown in clause D.1.1 of ETSI TS 137 141 [1].

5.3.4.2 Procedure

- 1) Set the Base Station to transmit at maximum power according to the applicable test configuration in clause 5 of ETSI TS 137 141 [1] using the corresponding test models or set of physical channels in clause 4.9.2 of ETSI TS 137 141 [1].
- 2) Measure the mean power for each carrier at the Base Station antenna connector.

In addition, for a multi-band capable BS, the following step shall apply:

- 3) For multi-band capable BS and single band tests, repeat the steps above per involved band where single band test configurations and test models shall apply with no carrier activated in the other band. For multi-band capable BS with separate antenna connector, the antenna connector not being under test in case of SBT or MBT shall be terminated.

5.3.4.3 Test requirement

The results obtained shall be compared to the limits in clause 4.2.5.2 in order to prove compliance.

5.3.5 Transmit intermodulation

5.3.5.0 General

For the referenced requirements in the present clause, where the tables with test configurations in clause 5 of ETSI TS 137 141 [1] refer to single-RAT specifications, the following shall apply:

- For references to "TS 25.141", the test suite specified in ETSI EN 301 908-3 [6], clauses 5.3.5.1 and 5.3.5.2 shall be used.

- For references to "TS 25.142", the test suite specified in ETSI TS 125 142 [13], clause 6.7.4 shall be used.
- For references to "TS 36.141", the test suite specified in ETSI EN 301 908-14 [7], clauses 5.3.5.1 and 5.3.5.2 shall be used.

In these three cases the limits of the present document defined in clauses 4.2.2.2, 4.2.3.2 and 4.2.4.2 shall apply.

- For GSM/EDGE single-RAT requirements, the test suite specified in ETSI EN 301 502 [9], applicable parts of clause 5.3.6 shall be used.

In this case the limits of ETSI EN 301 502 [9] defined in the applicable parts of clause 4.2.6.2 shall apply.

5.3.5.1 Initial conditions

Test environment: normal; see clause B.2 of ETSI TS 137 141 [1].

Base Station RF bandwidth position to be tested: according to the initial conditions specified in clauses 5.3.1, 5.3.2 and 5.3.3.

Connect the signal analyser to the Base Station antenna connector as shown in clause D.1.2 of ETSI TS 137 141 [1].

5.3.5.2 Procedure

5.3.5.2.1 General minimum requirement test procedure

- 1) Set the BS to transmit the test signal according to clause 5 of ETSI TS 137 141 [1] at maximum output power according to the applicable test configuration.
- 2) Generate the interfering signal using E-TM1.1 as defined in ETSI TS 136 141 [11], clause 6.1.1.1, with 5 MHz channel bandwidth, at a centre frequency offset according to the conditions in table 4.2.6.2.1-1 but exclude interfering frequencies that are outside of the allocated downlink operating band or interfering frequencies that are not completely within the sub-block gap or within the Inter RF bandwidth gap.
- 3) Adjust ATT1 so that level of the E-UTRA interfering signal is as defined in table 4.2.6.2.1-1.
- 4) If the test signal is applicable according to clause 5 of ETSI TS 137 141 [1], perform the Out-of-band emission tests as specified in clauses 5.3.1 and 5.3.2, for all third and fifth order intermodulation products which appear in the frequency ranges defined in clauses 5.3.1 and 5.3.2. The width of the intermodulation products shall be taken into account.
- 5) If the test signal is applicable according to clause 5 of ETSI TS 137 141 [1], perform the Transmitter spurious emissions test as specified in clause 5.3.3, for all third and fifth order intermodulation products which appear in the frequency ranges defined in clause 5.3.3. The width of the intermodulation products shall be taken into account.
- 6) Verify that the emission level does not exceed the required level with the exception of interfering signal frequencies.
- 7) Repeat the test for the remaining interfering signal centre frequency offsets according to the conditions of table 4.2.6.2.1-1.
- 8) Repeat the test for the remaining test signals defined in clause 5 in ETSI TS 137 141 [1] for requirements clauses 5.3.1, 5.3.2 and 5.3.3.

In addition, for a multi-band capable BS, the following step shall apply:

- 9) For multi-band capable BS and single band tests, repeat the steps above per involved band where single band test configurations and test models shall apply with no carrier activated in the other band. For multi-band capable BS with separate antenna connector, the antenna connector not being under test shall be terminated.

NOTE: The third order intermodulation products are centred at $2F1 \pm F2$ and $2F2 \pm F1$. The fifth order intermodulation products are centred at $3F1 \pm 2F2$, $3F2 \pm 2F1$, $4F1 \pm F2$, and $4F2 \pm F1$ where $F1$ represents the test signal centre frequency or centre frequency of each sub-block gap and $F2$ represents the interfering signal centre frequency. The widths of intermodulation products are:

- $(n \times BW_{F1} + m \times 5 \text{ MHz})$ for the $nF1 \pm mF2$ products;
- $(n \times 5 \text{ MHz} + m \times BW_{F1})$ for the $nF2 \pm mF1$ products;

where BW_{F1} represents the test signal RF bandwidth, or channel bandwidth in case of single carrier, or sub-block bandwidth.

5.3.5.2.2 Additional minimum requirement (BC1 and BC2) test procedure

- 1) Set the BS to transmit the test signal according to clause 5 of ETSI TS 137 141 [1] at maximum output power according to the applicable test configuration.
- 2) Generate a CW signal as the interfering signal with a centre frequency offset of 0,8 MHz, but exclude interfering frequencies that are outside of the allocated downlink operating band or interfering frequencies in a sub-block gap or in the Inter RF bandwidth gap, in case the gap is smaller than two times the interfering signal centre frequency offset.
- 3) Adjust ATT1 so that level of the interfering signal is as defined in table 4.2.6.2.2-1.
- 4) If the test signal is applicable according to clause 5 of ETSI TS 137 141 [1], perform the Out-of-band emission tests as specified in clauses 5.3.1 and 5.3.2, for all third and fifth order intermodulation products which appear in the frequency ranges defined in clauses 5.3.1 and 5.3.2.
- 5) If the test signal is applicable according to clause 5 of ETSI TS 137 141 [1], perform the Transmitter spurious emissions test as specified in clause 5.3.3, for all third and fifth order intermodulation products which appear in the frequency ranges defined in clause 5.3.3.
- 6) Verify that the emission level does not exceed the required level with the exception of interfering signal frequencies.
- 7) Repeat the test for interfering signal centre frequency offsets of 2,0 MHz, 3,2 MHz and 6,2 MHz.
- 8) Repeat the test for the remaining test signals defined in clause 5 of ETSI TS 137 141 [1] for requirements 5.3.1, 5.3.2 and 5.3.3.

In addition, for a multi-band capable BS, the following step shall apply:

- 9) For multi-band capable BS and single band tests, repeat the steps above per involved band where single band test configurations and test models shall apply with no carrier activated in the other band. For multi-band capable BS with separate antenna connector, the antenna connector not being under test shall be terminated.

NOTE: The third order intermodulation products are centred at $2F1 \pm F2$ and $2F2 \pm F1$. The fifth order intermodulation products are centred at $3F1 \pm 2F2$, $3F2 \pm 2F1$, $4F1 \pm F2$, and $4F2 \pm F1$ where $F1$ represents the test signal centre frequency or centre frequency of each sub-block and $F2$ represents the interfering signal centre frequency. The widths of intermodulation products are:

- $(n \times BW_{F1})$ for the $nF1 \pm mF2$ products;
- $(m \times BW_{F1})$ for the $nF2 \pm mF1$ products;

where BW_{F1} represents the test signal RF bandwidth, or channel bandwidth in case of single carrier, or sub-block bandwidth.

5.3.5.2.3 Additional minimum requirement (BC3) test procedure

- 1) Set the BS to transmit the test signal according to clause 5 of ETSI TS 137 141 [1] at maximum output power according to the applicable test configuration.
- 2) Generate the interfering signal according to table 6.38A in ETSI TS 125 142 [13] at a centre frequency offset according to the conditions in table 4.2.6.2.3-1, but exclude interfering frequencies that are outside of the allocated downlink operating band.
- 3) Adjust ATT1 so that level of the interfering signal is as defined in table 4.2.6.2.3-1.
- 4) If the test signal is applicable according to clause 5 of ETSI TS 137 141 [1], perform the Out-of-band emission tests as specified in clauses 5.3.1 and 5.3.2, for all third and fifth order intermodulation products which appear in the frequency ranges defined in clauses 5.3.1 and 5.3.2. The width of the intermodulation products shall be taken into account.
- 5) If the test signal is applicable according to clause 5 of ETSI TS 137 141 [1], perform the Transmitter spurious emissions test as specified in clause 5.3.3 for all third and fifth order intermodulation products which appear in the frequency ranges defined in clause 5.3.3. The width of the intermodulation products shall be taken into account.
- 6) Verify that the emission level does not exceed the required level with the exception of interfering signal frequencies.
- 7) Repeat the test for the remaining interfering signal centre frequency offsets according to the conditions of table 4.2.6.2.3-1.
- 8) Repeat the test for the remaining signal models and physical channels in clause 5 in ETSI TS 137 141 [1].

In addition, for a multi-band capable BS, the following step shall apply:

- 9) For multi-band capable BS and single band tests, repeat the steps above per involved band where single band test configurations and test models shall apply with no carrier activated in the other band. For multi-band capable BS with separate antenna connector, the antenna connector not being under test shall be terminated.

NOTE: The third order intermodulation products are centred at $2F1 \pm F2$ and $2F2 \pm F1$. The fifth order intermodulation products are centred at $3F1 \pm 2F2$, $3F2 \pm 2F1$, $4F1 \pm F2$, and $4F2 \pm F1$ where $F1$ represents the test signal centre frequency or centre frequency of each sub-block and $F2$ represents the interfering signal centre frequency. The widths of intermodulation products are:

- $(n \times BW_{F1} + m \times 1,6 \text{ MHz})$ for the $nF1 \pm mF2$ products;
- $(n \times 1,6 \text{ MHz} + m \times BW_{F1})$ for the $nF2 \pm mF1$ products;

where BW_{F1} represents the test signal RF bandwidth, or channel bandwidth in case of single carrier, or sub-block bandwidth.

5.3.5.3 Test requirement

The results obtained shall be compared to the limits in clause 4.2.6.2 in order to prove compliance.

5.3.6 Receiver spurious emissions

5.3.6.1 Initial conditions

Test environment: normal; see clause B.2 of ETSI TS 137 141 [1].

Base Station RF bandwidth positions to be tested:

- M_{RFBW} in single-band operation, see clause 4.9.1 of ETSI TS 137 141 [1].
- $B_{RFBW-T'_{RFBW}}$ and $B'_{RFBW-T_{RFBW}}$ in multi-band operation, see clause 4.9.1 of ETSI TS 137 141 [1].

Test set-up:

- 1) Set up the equipment as shown in clause D.2.1 of ETSI TS 137 141 [1].

5.3.6.2 Procedure

- 1) Set the measurement equipment parameters as specified in table 4.2.7.2.1-1. For BC2, the parameters in table 4.2.7.2.1-2 shall apply in addition.
- 2) Set the BS to transmit with the carrier set-up and power allocation according to the applicable test configuration(s) (see clause 5 of ETSI TS 137 141 [1]).
- 3) Measure the spurious emissions over each frequency range described in clause 4.2.7.2.

In addition, for a multi-band capable BS, the following step shall apply:

- 4) For multi-band capable BS and single band tests, repeat the steps above per involved band where single band test configurations and test models shall apply with no carrier activated in the other band. For multi-band capable BS with separate antenna connector, the antenna connector not being under test in case of SBT or MBT shall be terminated.

5.3.6.3 Test requirement

The results obtained shall be compared to the limits in clause 4.2.7.2 in order to prove compliance.

5.3.7 In-band blocking

5.3.7.1 Initial conditions

Test environment: normal; see clause B.2 of ETSI TS 137 141 [1].

Base Station RF bandwidth positions to be tested:

- M_{RFBW} in single-band operation, see clause 4.9.1 of ETSI TS 137 141 [1].
- $B_{RFBW-T'_{RFBW}}$ and $B'_{RFBW-T_{RFBW}}$ in multi-band operation, see clause 4.9.1 of ETSI TS 137 141 [1].

Test set-up:

- 1) Set up the equipment as shown in clause D.2.1 of ETSI TS 137 141 [1].
- 2) Generate the wanted signal according to the applicable test configuration (see clause 5 of ETSI TS 137 141 [1]) using applicable reference measurement channel to the BS under test as follows:
 - For E-UTRA see clause A.1 in ETSI TS 136 141 [11].
 - For UTRA FDD see clause A.2 in ETSI TS 125 141 [12].
 - For UTRA TDD see clause A.2.1 in ETSI TS 125 142 [13].
 - For GSM see clause 5.3.12 in ETSI EN 301 502 [9] and annex P in ETSI TS 145 005 [5] for reference channels to test.

5.3.7.2 Procedure

5.3.7.2.1 Procedure for general blocking

- 1) Set the BS to transmit with the carrier set-up and power allocation according to the applicable test configuration(s) (see clause 5 of ETSI TS 137 141 [1]).
- 2) Adjust the signal generators to the type of interfering signal, levels and the frequency offsets as specified in table 4.2.8.2.1-1.

- 3) The interfering signal shall be swept with a step size of 1 MHz starting from the minimum offset to the channel edges of the wanted signals as specified in table 4.2.8.2.1-1.
- 4) Measure the performance of the wanted signal at the BS receiver, as defined in clause 4.2.8.2.1, for the relevant carriers specified by the test configuration in clause 4.8 of ETSI TS 137 141 [1].

In addition, for a multi-band capable BS with separate antenna connectors, the following steps shall apply:

- 5) For single band tests, repeat the steps above per involved band where single band test configurations and test models shall apply with no carrier activated in the other band.
- 6) For multiband tests, the interfering signal shall first be applied on the same port as the wanted signal. The test shall be repeated with the interfering signal applied on the other port (if any) mapped to the same receiver as the wanted signal. Any antenna connector with no signal applied shall be terminated.
- 7) Repeat step 6 with the wanted signal for the other(s) bands applied on the respective port(s).

5.3.7.2.2 Procedure for additional BC3 blocking requirement

- 1) Adjust the signal generators to the type of interfering signal, levels and the frequency offsets as specified in table 4.2.8.2.2-1.
- 2) Measure the performance of the wanted signal at the BS receiver, as defined in clause 4.2.8.2.2, for the relevant carriers specified by the test configuration in clause 4.8 of ETSI TS 137 141 [1].

5.3.7.3 Test requirement

The results obtained shall be compared to the limits in clause 4.2.8.2 in order to prove compliance.

5.3.8 Out-of-band blocking

5.3.8.1 Initial conditions

Test environment: normal; see clause B.2 of ETSI TS 137 141 [1].

Base Station RF bandwidth positions to be tested:

- M_{RFBW} in single-band operation, see clause 4.9.1 of ETSI TS 137 141 [1].
- $B_{\text{RFBW-T}'_{\text{RFBW}}}$ and $B'_{\text{RFBW-T}_{\text{RFBW}}}$ in multi-band operation, see clause 4.9.1 of ETSI TS 137 141 [1].

In addition, in multi-band operation:

- For $B_{\text{RFBW-T}'_{\text{RFBW}}}$, out-of-band blocking testing above the highest operating band may be omitted.
- For $B'_{\text{RFBW-T}_{\text{RFBW}}}$, out-of-band blocking testing below the lowest operating band may be omitted.

Test set-up:

- 1) Set up the equipment as shown in clause D.2.1 of ETSI TS 137 141 [1].
- 2) Generate the wanted signal according the applicable test configuration (see clause 5 of ETSI TS 137 141 [1]) using to reference measurement channel to the BS under test as follows:
 - For E-UTRA see clause A.1 in ETSI TS 136 141 [11].
 - For UTRA FDD see clause A.2 in ETSI TS 125 141 [12].
 - For UTRA TDD see clause A.2.1 in ETSI TS 125 142 [13].
 - For GSM see clause 5.3.12 in ETSI EN 301 502 [9] and annex P in ETSI TS 145 005 [5] for reference channels to test. Irrespective of the logical channels supported by the BS under test, the test is performed for GMSK modulated channels only.

5.3.8.2 Procedure

- 1) Set the BS to transmit with the carrier set-up and power allocation according to the applicable test configuration(s) (see clause 5 of ETSI TS 137 141 [1]). The transmitter may be turned off for the out-of-band blocker tests when the frequency of the blocker is such that no IM2 or IM3 products fall inside the bandwidth of the wanted signal.
- 2) Adjust the signal generators to the type of interfering signals, levels and the frequency offsets as specified for the test requirements in table 4.2.9.2-1.
- 3) The CW interfering signal shall be swept with a step size of 1 MHz within the specified range.
- 4) Measure the performance of the wanted signal at the BS receiver, as defined in the clause 4.2.9.2, for the relevant carriers specified by the test configuration in clause 4.8 of ETSI TS 137 141 [1].

In addition, for a multi-band capable BS with separate antenna connectors, the following steps shall apply:

- 5) For single band tests, repeat the steps above per involved band where single band test configurations and test models shall apply with no carrier activated in the other band.
- 6) For multiband tests, the interfering signal shall first be applied on the same port as the wanted signal. The test shall be repeated with the interfering signal applied on the other port (if any) mapped to the same receiver as the wanted signal. Any antenna connector with no signal applied shall be terminated.
- 7) Repeat step 6 with the wanted signal for the other band(s) applied on the respective port(s).

5.3.8.3 Test requirement

The results obtained shall be compared to the limits in clause 4.2.9.2 in order to prove compliance.

5.3.9 Receiver intermodulation characteristics

5.3.9.1 Initial conditions

Test environment: Normal; see clause B.2 of ETSI TS 137 141 [1].

Base Station RF bandwidth positions to be tested:

- In single-band operation: M_{RFBW} if TC6 is applicable; B_{RFBW} and T_{RFBW} for other TC, see clause 4.9.1, tables 5.1-1 and 5.2-1 of ETSI TS 137 141 [1].
- In multi- band operation: $B_{\text{RFBW}}-T'_{\text{RFBW}}$ and $B'_{\text{RFBW}}-T_{\text{RFBW}}$, see clause 4.9.1 of ETSI TS 137 141 [1].

Test set-up:

- 1) Set-up the measurement system as shown in clause D.2.3 of ETSI TS 137 141 [1].
- 2) Generate the wanted signal according to the applicable test configuration (see clause 5 of ETSI TS 137 141 [1]) using reference measurement channel to the BS under test as follows:
 - For E-UTRA see clause A.1 in ETSI TS 136 141 [11].
 - For UTRA FDD see clause A.2 in ETSI TS 125 141 [12].
 - For UTRA TDD see clause A.2.1 in ETSI TS 125 142 [13].
 - For GSM see clause 5.3.13 in ETSI EN 301 502 [9] and annex P in ETSI TS 145 005 [5] for reference channels to test.

5.3.9.2 Procedure

5.3.9.2.1 Procedure for general and narrowband intermodulation

- 1) Adjust the signal generators to the type of interfering signals, levels and the frequency offsets as specified in tables 4.2.10.2.1-1 and 4.2.10.2.1-2 for the general intermodulation requirement, and tables 4.2.10.2.2-1 and 4.2.10.2.2-2 for the narrowband intermodulation requirement.
- 2) Measure the performance of the wanted signal at the BS receiver, as defined in clauses 4.2.10.2.1 and 4.2.10.2.2, for the relevant carriers specified by the test configuration in clause 4.8 of ETSI TS 137 141 [1].

In addition, for a multi-band capable BS with separate antenna connectors, the following steps shall apply:

- 3) For single band tests, repeat the steps above per involved band where single band test configurations shall apply with no carrier activated in the other band.
- 4) For multiband tests, the interfering signal shall first be applied on the same port as the wanted signal. The test shall be repeated with the interfering signal applied on the other port (if any) mapped to the same receiver as the wanted signal. Any antenna connector with no signal applied shall be terminated.
- 5) Repeat step 4 with the wanted signal for the other band(s) applied on the respective port(s).

5.3.9.2.2 Procedure for additional narrowband intermodulation for GSM/EDGE

The GSM/EDGE MC-BTS receiver intermodulation method of test is stated in ETSI EN 301 502 [9] applicable parts of clause 5.3.13, shall apply for GSM/EDGE carriers.

The conditions specified in ETSI TS 145 005 [5], clause P.2.2 shall apply for the GSM/EDGE intermodulation requirement.

In addition, for multi-band capable BS and single band tests, repeat the procedure above per involved band where single band test configurations and test models shall apply with no carrier activated in the other band. Any antenna connector with no signal applied shall be terminated.

5.3.9.3 Test requirement

The results obtained shall be compared to the limits in clause 4.2.10.2 in order to prove compliance.

5.3.10 Narrowband blocking

5.3.10.1 Initial conditions

Test environment: Normal; see clause B.2 of ETSI TS 137 141 [1].

Base Station RF bandwidth positions to be tested:

- M_{RFBW} in single-band operation, see clause 4.9.1 of ETSI TS 137 141 [1].
- $B_{\text{RFBW-T}_{\text{RFBW}}}$ and $B'_{\text{RFBW-T}_{\text{RFBW}}}$ in multi-band operation, see clause 4.9.1 of ETSI TS 137 141 [1].

Test set-up:

- 1) Set up the equipment as shown in clause D.2.1 of ETSI TS 137 141 [1].
- 2) Generate the wanted signal according to the applicable test configuration (see clause 5 of ETSI TS 137 141 [1]) using applicable reference measurement channel to the BS under test as follows:
 - For E-UTRA see clause A.1 in ETSI TS 136 141 [11].
 - For UTRA FDD see clause A.2 in ETSI TS 125 141 [12].
 - For UTRA TDD see clause A.2.1 in ETSI TS 125 142 [13].

- For GSM see clause 5.3.12 in ETSI EN 301 502 [9] and annex P in ETSI TS 145 005 [5] for reference channels to test.

5.3.10.2 Procedure

5.3.10.2.1 Procedure for narrowband blocking

- 1) Set the BS to transmit with the carrier set-up and power allocation according to the applicable test configuration(s) (see clause 5 of ETSI TS 137 141 [1]).
- 2) Adjust the signal generators to the type of interfering signal, levels and the frequency offsets as specified in table 4.2.11.2.1-1.
- 3) Set-up and sweep the interfering RB centre frequency offset to the channel edge of the wanted signal according to table 4.2.11.2.1-1.
- 4) Measure the performance of the wanted signal at the BS receiver, as defined in clause 4.2.11.2.1, for the relevant carriers specified by the test configuration in clause 4.8 of ETSI TS 137 141 [1].

In addition, for a multi-band capable BS with separate antenna connectors, the following steps shall apply:

- 5) For single band tests, repeat the steps above per involved band where single band test configurations and test models shall apply with no carrier activated in the other band.
- 6) For multiband tests, the interfering signal shall first be applied on the same port as the wanted signal. The test shall be repeated with the interfering signal applied on the other port (if any) mapped to the same receiver as the wanted signal. Any antenna connector with no signal applied shall be terminated.
- 7) Repeat step 6 with the wanted signal for the other band(s) applied on the respective port(s).

5.3.10.2.2 Procedure for additional narrowband blocking for GSM/EDGE

The GSM/EDGE in-band blocking method of test is stated in ETSI EN 301 502 [9], applicable parts of clause 5.3.12.

The conditions specified in ETSI TS 145 005 [5], clause P.2.1 shall apply for GSM/EDGE in-band narrowband blocking.

In addition, for multi-band capable BS and single band tests, repeat the procedure above per involved band where single band test configurations and test models shall apply with no carrier activated in the other band. Any antenna connector with no signal applied shall be terminated.

5.3.10.2.3 Procedure for GSM/EDGE AM suppression

The GSM/EDGE in-band blocking method of test is stated in ETSI EN 301 502 [9], applicable parts of clause 5.3.14.

The conditions specified in ETSI TS 145 005 [5], clause P.2.3 shall apply for GSM/EDGE AM suppression.

In addition, for multi-band capable BS and single band tests, repeat the procedure above per involved band where single band test configurations and test models shall apply with no carrier activated in the other band. Any antenna connector with no signal applied shall be terminated.

5.3.10.3 Test requirement

The results obtained shall be compared to the limits in clause 4.2.11.2 in order to prove compliance.

5.3.11 Reference sensitivity level

5.3.11.1 General

For the Reference sensitivity requirement, the tables with test configurations in clause 5 of ETSI TS 137 141 [1] refer to the single-RAT specifications. The following shall apply:

- For references to "TS 25.141", the test suite specified in ETSI EN 301 908-3 [6], clause 5.3.11 shall be used.
- For references to "TS 25.142", the test suite specified in ETSI TS 125 142 [13], clause 7.2.4 shall be used.
- For references to "TS 36.141", the test suite specified in ETSI EN 301 908-14 [7], clause 5.3.13 shall be used.
- For references to "TS 51.021", the test suite specified in ETSI EN 301 502 [9], clause 5.3.9.

In addition, for a multi-band capable BS, the following steps shall apply:

- For multi-band capable BS and single band tests, repeat the tests per involved band where single carrier test models shall apply with no carrier activated in the other band. For multi-band capable BS with separate antenna connector, the antenna connector not being under test shall be terminated.

5.3.11.2 Test requirement

The results obtained shall be compared to the limits in clause 4.2.12 in order to prove compliance.

Annex A (normative): Relationship between the present document and the essential requirements of Directive 2014/53/EU

The present document has been prepared under the Commission's standardisation request C(2015) 5376 final [i.6] to provide one voluntary means of conforming to the essential requirements of Directive 2014/53/EU on the harmonisation of the laws of the Member States relating to the making available on the market of radio equipment and repealing Directive 1999/5/EC [i.1].

Once the present document is cited in the Official Journal of the European Union under that Directive, compliance with the normative clauses of the present document given in table A-1 confers, within the limits of the scope of the present document, a presumption of conformity with the corresponding essential requirements of that Directive and associated EFTA regulations.

Table A-1: Relationship between the present document and the essential requirements of Directive 2014/53/EU

Harmonised Standard ETSI EN 301 908-18				
The following requirements are relevant to the presumption of conformity under the article 3.2 of Directive 2014/53/EU [i.1]				
Requirement			Requirement Conditionality	
No	Description	Reference: Clause No	U/C	Condition
1	Operating band unwanted emissions	4.2.2	U	
2	Adjacent Channel Leakage power Ratio (ACLR)	4.2.3	U	
3	Transmitter spurious emissions	4.2.4	U	
4	Base station maximum output power	4.2.5	U	
5	Transmit intermodulation	4.2.6	U	
6	Receiver spurious emissions	4.2.7	U	
7	In-band blocking	4.2.8	U	
8	Out-of-band blocking	4.2.9	U	
9	Receiver intermodulation characteristics	4.2.10	U	
10	Narrowband blocking	4.2.11	U	
11	Reference sensitivity level	4.2.12	U	

Key to columns:

Requirement:

No A unique identifier for one row of the table which may be used to identify a requirement.

Description A textual reference to the requirement.

Clause Number Identification of clause(s) defining the requirement in the present document unless another document is referenced explicitly.

Requirement Conditionality:

U/C Indicates whether the requirement shall be unconditionally applicable (U) or is conditional upon the manufacturer's claimed functionality of the equipment (C).

Condition Explains the conditions when the requirement shall or shall not be applicable for a requirement which is classified "conditional".

Presumption of conformity stays valid only as long as a reference to the present document is maintained in the list published in the Official Journal of the European Union. Users of the present document should consult frequently the latest list published in the Official Journal of the European Union.

Other Union legislation may be applicable to the product(s) falling within the scope of the present document.

Annex B (normative): Base Station configurations

B.1 Reception with multiple receiver antenna connectors and receiver diversity

For the tests in clause 5, the requirement shall apply at each receiver antenna connector for receivers with antenna diversity or in the case of multi-carrier reception with multiple receiver antenna connectors.

Receiver requirements are tested at the antenna connector, with the remaining receiver(s) disabled or their antenna connector(s) being terminated. If the manufacturer has declared the receiver paths to be equivalent, it is sufficient to apply the specified test signal at any one of the receiver antenna connectors.

For a multi-band BS, multi-band tests for blocking and intermodulation are performed with the interferer(s) applied to each antenna connector mapped to the receiver for the wanted signal(s), however only to one antenna at a time. Antenna connectors to which no signals are applied are terminated.

B.2 Duplexers

The requirements of the present document shall be met with a duplexer fitted, if a duplexer is supplied as part of the BS.

B.3 Power supply options

If the BS is supplied with a number of different power supply configurations, it may not be necessary to test RF parameters for each of the power supply options, provided that it can be demonstrated that the range of conditions over which the equipment is tested is at least as great as the range of conditions due to any of the power supply configurations.

This shall apply particularly if a BS contains a DC rail which can be supplied either externally or from an internal mains power supply. In this case, the conditions of extreme power supply for the mains power supply options can be tested by testing only the external DC supply option. The range of DC input voltages for the test should be sufficient to verify the performance with any of the power supplies, over its range of operating conditions within the BS, including variation of mains input voltage, temperature and output current.

B.4 Ancillary RF amplifiers

The requirements of the present document shall be met with the ancillary RF amplifier fitted. At tests according to clauses 5, the ancillary amplifier is connected to the BS by a connecting network (including any cable(s), attenuator(s), etc.) with applicable loss to make sure the appropriate operating conditions of the ancillary amplifier and the BS. The applicable connecting network loss range is declared by the manufacturer. Other characteristics and the temperature dependence of the attenuation of the connecting network are neglected. The actual attenuation value of the connecting network is chosen for each test as one of the applicable extreme values. The lowest value is used unless otherwise stated.

Sufficient tests should be repeated with the ancillary amplifier fitted and, if it is optional, without the ancillary RF amplifier to verify that the BS meets the requirements of the present document in both cases.

When testing, the following tests shall be repeated with the optional ancillary amplifier fitted according to table B.4-1, where x denotes that the test shall apply.

Table B.4-1: Tests applicable to Ancillary RF Amplifiers

	Clause	TX amplifier only	RX amplifier only	TX/RX amplifiers combined (see note)
Receiver Tests	5.3.6		X	X
	5.3.7		X	X
	5.3.8		X	X
	5.3.9		X	
	5.3.11		X	X
Transmitter Tests	5.3.1	X		X
	5.3.2	X		X
	5.3.3	X		X
	5.3.4	X		X
	5.3.5	X		X
NOTE: Combining can be by duplex filters or any other network. The amplifiers can either be in RX or TX branch or in both. Either one of these amplifiers could be a passive network.				

In test according to clauses 5.3.4 highest applicable attenuation value is applied.

B.5 BS using antenna arrays

B.5.0 General

A BS may be configured with a multiple antenna port connection for some or all of its transceivers or with an antenna array related to one cell (not one array per transceiver). This clause shall apply to a BS which meets at least one of the following conditions:

- the transmitter output signals from one or more transceiver appear at more than one antenna port; or
- there is more than one receiver antenna port for a transceiver or per cell and an input signal is required at more than one port for the correct operation of the receiver thus the outputs from the transmitters as well as the inputs to the receivers are directly connected to several antennas (known as "aircombining"); or
- transmitters and receivers are connected via duplexers to more than one antenna.

In case of diversity or spatial multiplexing, multiple antennas are not considered as an antenna array.

If a BS is used, in normal operation, in conjunction with an antenna system which contains filters or active elements which are necessary to meet the E-UTRA requirements, the conformance tests may be performed on a system comprising the BS together with these elements, supplied separately for the purposes of testing. In this case, it shall be demonstrated that the performance of the configuration under test is representative of the system in normal operation, and the conformance assessment is only applicable when the BS is used with the antenna system.

For conformance testing of such a BS, the following procedure may be used.

B.5.1 Receiver tests

For each test, the test signals applied to the receiver antenna connectors shall be such that the sum of the powers of the signals applied equals the power of the test signal(s) specified in the test.

An example of a suitable test configuration is shown in figure B.5.1-1.

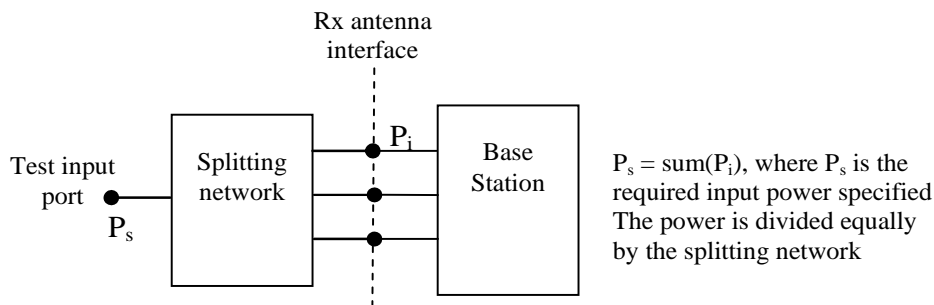

Figure B.5.1-1: Receiver test set-up

For spurious emissions from the receiver antenna connector, the test may be performed separately for each receiver antenna connector.

B.5.2 Transmitter tests

For each test, the test signals applied to the transmitter antenna connectors (P_i) shall be such that the sum of the powers of the signals applied equals the power of the test signal(s) (P_s) specified in the test. This may be assessed by separately measuring the signals emitted by each antenna connector and summing the results, or by combining the signals and performing a single measurement. The characteristics (e.g. amplitude and phase) of the combining network should be such that the power of the combined signal is maximized.

An example of a suitable test configuration is shown in figure B.5.2-1.

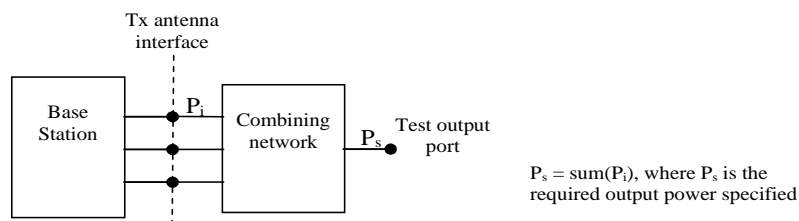

Figure B.5.2-1: Transmitter test set-up

For Intermodulation attenuation, the test may be performed separately for each transmitter antenna connector.

B.6 Transmission with multiple transmitter antenna connectors

Unless otherwise stated, for the tests in clause 5, the requirement shall apply for each transmitter antenna connector in case of transmission with multiple transmitter antenna connectors.

Transmitter requirements are tested at the antenna connector, with the remaining antenna connector(s) being terminated. If the manufacturer has declared the transmitter paths to be equivalent, it is sufficient to measure the signal at any one of the transmitter antenna connectors.

B.7 BS with integrated Iuant BS modem

Unless otherwise stated, for the tests in the present document, the integrated Iuant BS modem shall be switched off. Spurious emissions according to clauses 5.3.3 and 5.3.6 shall be measured only for frequencies above 20 MHz with the integrated Iuant BS modem switched on.

Annex C (informative): Environmental profile specification

The following environmental conditions may be declared by the manufacturer:

- barometric pressure: minimum and maximum;
- temperature: minimum and maximum;
- relative humidity: minimum and maximum;
- power supply: lower and upper voltage limit.

When operating outside the boundary limits of the declared operational environmental profile the equipment should not make ineffective use of the radio frequency spectrum so as to cause harmful interference.

Annex D (informative): Bibliography

- Directive 2004/108/EC of the European Parliament and of the Council of 15 December 2004 on the approximation of the laws of the Member States relating to electromagnetic compatibility and repealing Directive 89/336/EEC (EMC Directive).
- Directive 2006/95/EC of the European Parliament and of the Council of 12 December 2006 on the harmonisation of the laws of Member States relating to electrical equipment designed for use within certain voltage limits (LV Directive).
- CEPT/ERC/REC 74-01 (Siófok 1998, Nice 1999, Sesimbra 2002, Hradec Kralove 2005, Cardiff 2011): "Unwanted Emissions in the Spurious Domain".
- Commission Decision 2008/477/EC of 13 June 2008 on the harmonisation of the 2 500-2 690 MHz frequency band for terrestrial systems capable of providing electronic communications services in the Community.
- Commission Decision 2010/267/EU of 6 May 2010 on harmonised technical conditions of use in the 790-862 MHz frequency band for terrestrial systems capable of providing electronic communications services in the European Union.
- Commission Implementing Decision 2012/688/EU of 5 November 2012 on the harmonisation of the frequency bands 1 920-1 980 MHz and 2 110-2 170 MHz for terrestrial systems capable of providing electronic communications services in the Union.
- Commission Implementing Decision (EU) 2015/750 of 8 May 2015 on the harmonisation of the 1 452-1 492 MHz frequency band for terrestrial systems capable of providing electronic communications services in the Union.
- ECC Decision (13)03: "The harmonised use of the frequency band 1452-1492 MHz for Mobile/Fixed Communications Networks Supplemental Downlink (MFCN SDL)".
- ECC Decision (15)01: "Harmonised technical conditions for mobile/fixed communications networks (MFCN) in the band 694-790 MHz including a paired frequency arrangement (Frequency Division Duplex 2x30 MHz) and an optional unpaired frequency arrangement (Supplemental Downlink)", Approved 06 March 2015.
- Directive 98/34/EC of the European Parliament and of the Council of 22 June 1998 laying down a procedure for the provision of information in the field of technical standards and regulations.
- Directive 98/48/EC of the European Parliament and of the Council of 20 July 1998 amending Directive 98/34/EC laying down a procedure for the provision of information in the field of technical standards and regulations.
- Regulation (EU) No 1025/2012 of the European Parliament and of the Council of 25 October 2012 on European standardisation amending Council Directives 89/686/EEC and 93/15/EEC and Directives 94/9/EC, 94/25/EC, 95/16/EC, 97/23/EC, 98/34/EC, 2004/22/EC, 2007/23/EC, 2009/23/EC and 2009/105/EC of the European Parliament and of the Council and repealing Council Decision 87/95/EEC and Decision No 1673/2006/EC of the European Parliament and of the Council.

History

Document history				
V5.2.1	July 2011	Publication		
V6.2.1	November 2012	Publication		
V7.1.1	July 2014	Publication		
V7.1.2	July 2014	Publication		
V11.0.1	January 2016	EN Approval Procedure	AP 20160420:	2016-01-21 to 2016-04-20
V11.1.0	May 2016	Vote	V 20160712:	2016-05-13 to 2016-07-12
V11.1.1	July 2016	Publication		