

**Base Stations (BS), Repeaters and User Equipment (UE)  
for IMT-2000 Third-Generation cellular networks;  
Part 18: Harmonized EN for Multi-Standard Radio  
(UTRA, E-UTRA, GSM/EDGE) Base Stations (BS)  
covering the essential requirements  
of article 3.2 of the R&TTE Directive**

---



---

Reference

DEN/MSG-TFES-009-18

---

Keywords

3G, 3GPP, cellular, digital, EDGE, GSM, E-UTRA  
IMT-2000, LTE, mobile, MSR, radio, regulation,  
UMTS, UTRA, WCDMA

**ETSI**

650 Route des Lucioles  
F-06921 Sophia Antipolis Cedex - FRANCE

Tel.: +33 4 92 94 42 00 Fax: +33 4 93 65 47 16

Siret N° 348 623 562 00017 - NAF 742 C  
Association à but non lucratif enregistrée à la  
Sous-Préfecture de Grasse (06) N° 7803/88

---

**Important notice**

Individual copies of the present document can be downloaded from:

<http://www.etsi.org>

The present document may be made available in more than one electronic version or in print. In any case of existing or perceived difference in contents between such versions, the reference version is the Portable Document Format (PDF). In case of dispute, the reference shall be the printing on ETSI printers of the PDF version kept on a specific network drive within ETSI Secretariat.

Users of the present document should be aware that the document may be subject to revision or change of status. Information on the current status of this and other ETSI documents is available at

<http://portal.etsi.org/tb/status/status.asp>

If you find errors in the present document, please send your comment to one of the following services:

[http://portal.etsi.org/chaicor/ETSI\\_support.asp](http://portal.etsi.org/chaicor/ETSI_support.asp)

---

**Copyright Notification**

No part may be reproduced except as authorized by written permission.  
The copyright and the foregoing restriction extend to reproduction in all media.

© European Telecommunications Standards Institute 2010.  
All rights reserved.

**DECT™**, **PLUGTESTS™**, **UMTS™**, **TIPHON™**, the TIPHON logo and the ETSI logo are Trade Marks of ETSI registered for the benefit of its Members.

**3GPP™** is a Trade Mark of ETSI registered for the benefit of its Members and of the 3GPP Organizational Partners.

**LTE™** is a Trade Mark of ETSI currently being registered

for the benefit of its Members and of the 3GPP Organizational Partners.

**GSM®** and the GSM logo are Trade Marks registered and owned by the GSM Association.

# Contents

Intellectual Property Rights .....	6
Foreword.....	6
Introduction .....	7
1 Scope .....	8
2 References .....	8
2.1 Normative references .....	9
2.2 Informative references.....	10
3 Definitions, symbols and abbreviations .....	10
3.1 Definitions.....	10
3.2 Symbols.....	11
3.3 Abbreviations .....	11
4 Technical requirements specifications .....	12
4.1 Environmental profile.....	12
4.2 Conformance requirements .....	12
4.2.1 Introduction.....	12
4.2.2 Operating band unwanted emissions .....	13
4.2.2.1 Definition .....	13
4.2.2.2 Limits .....	13
4.2.2.2.1 Limits for Band Categories 1 and 3.....	13
4.2.2.2.2 Limits for Band Category 2.....	14
4.2.2.2.3 Limits for GSM/EDGE single-RAT operation.....	15
4.2.2.2.4 Limits for protection of DTT.....	15
4.2.2.2.5 Limits for co-existence with services in adjacent frequency bands.....	15
4.2.2.3 Conformance.....	16
4.2.3 Adjacent Channel Leakage power Ratio (ACLR) .....	16
4.2.3.1 Definition .....	16
4.2.3.2 Limits .....	16
4.2.3.2.1 E-UTRA limits .....	16
4.2.3.2.2 UTRA FDD limits .....	16
4.2.3.2.3 UTRA TDD limits.....	16
4.2.3.3 Conformance.....	16
4.2.4 Transmitter spurious emissions.....	16
4.2.4.1 Limits .....	17
4.2.4.1.1 Spurious emissions .....	17
4.2.4.1.2 Additional spurious emissions requirement for BC2.....	17
4.2.4.1.3 Co-existence with other systems .....	17
4.2.4.1.4 Protection of the BS receiver of own or different BS.....	19
4.2.4.2 Conformance.....	19
4.2.5 Base station maximum output power.....	19
4.2.5.1 Definition .....	19
4.2.5.2 Limits .....	19
4.2.5.3 Conformance.....	19
4.2.6 Transmit intermodulation .....	19
4.2.6.1 Definition .....	19
4.2.6.2 Limits .....	20
4.2.6.2.1 General limits .....	20
4.2.6.2.2 Additional limits (BC2).....	20
4.2.6.2.3 Additional limits (BC3).....	20
4.2.6.3 Conformance.....	21
4.2.7 Receiver spurious emissions .....	21
4.2.7.1 Definition .....	21
4.2.7.2 Limits .....	21
4.2.7.2.1 General limits .....	21

4.2.7.2.2	Additional limits for BC2 .....	21
4.2.7.3	Conformance .....	22
4.2.8	In-band blocking .....	22
4.2.8.1	Definition .....	22
4.2.8.2	Limits .....	22
4.2.8.2.1	General limits .....	22
4.2.8.2.2	Additional BC3 blocking limits .....	23
4.2.8.3	Conformance .....	23
4.2.9	Out-of-band blocking .....	23
4.2.9.1	Definition .....	23
4.2.9.2	Limits .....	23
4.2.9.3	Conformance .....	24
4.2.10	Receiver intermodulation characteristics .....	24
4.2.10.1	Definition .....	24
4.2.10.2	Limits .....	24
4.2.10.2.1	General intermodulation limits .....	24
4.2.10.2.2	General narrowband intermodulation limits .....	25
4.2.10.2.3	Additional narrowband intermodulation limits for GSM/EDGE .....	26
4.2.10.3	Conformance .....	26
4.2.11	Narrowband blocking .....	26
4.2.11.1	Definition .....	26
4.2.11.2	Limits .....	27
4.2.11.2.1	General limits .....	27
4.2.11.2.2	Additional limits for GSM/EDGE .....	27
4.2.11.2.3	GSM/EDGE limits for AM suppression .....	27
4.2.11.3	Conformance .....	27
5	Testing for compliance with technical requirements .....	27
5.1	Environmental conditions for testing .....	27
5.2	Interpretation of the measurement results .....	28
5.3	Essential radio test suites .....	29
5.3.1	Operating band unwanted emissions .....	29
5.3.1.1	Initial conditions .....	29
5.3.1.2	Procedure .....	30
5.3.1.3	Test requirement .....	30
5.3.2	Adjacent Channel Leakage power Ratio (ACLR) .....	30
5.3.3	Transmitter spurious emissions .....	30
5.3.3.1	Initial conditions .....	30
5.3.3.2	Procedure .....	31
5.3.3.3	Test requirement .....	31
5.3.4	Base station maximum output power .....	31
5.3.4.1	Initial conditions .....	31
5.3.4.2	Procedure .....	31
5.3.4.3	Test requirement .....	31
5.3.5	Transmit intermodulation .....	31
5.3.5.1	Initial conditions .....	31
5.3.5.2	Procedure .....	31
5.3.5.2.1	General minimum requirement test procedure .....	31
5.3.5.2.2	Additional minimum requirement (BC2) test procedure .....	32
5.3.5.2.3	Additional minimum requirement (BC3) test procedure .....	33
5.3.5.3	Test requirement .....	33
5.3.6	Receiver spurious emissions .....	33
5.3.6.1	Initial conditions .....	33
5.3.6.2	Procedure .....	34
5.3.6.3	Test requirement .....	34
5.3.7	In-band blocking .....	34
5.3.7.1	Initial conditions .....	34
5.3.7.2	Procedure .....	34
5.3.7.2.1	Procedure for general blocking .....	34
5.3.7.2.2	Procedure for additional BC3 blocking requirement .....	34
5.3.7.3	Test requirement .....	34
5.3.8	Out-of-band blocking .....	35

5.3.8.1	Initial conditions .....	35
5.3.8.2	Procedure .....	35
5.3.8.3	Test requirement .....	35
5.3.9	Receiver intermodulation characteristics .....	35
5.3.9.1	Initial conditions .....	35
5.3.9.2	Procedure .....	36
5.3.9.2.1	Procedure for general and narrowband intermodulation .....	36
5.3.9.2.2	Procedure for additional narrowband intermodulation for GSM/EDGE .....	36
5.3.9.3	Test requirement .....	36
5.3.10	Narrowband blocking .....	36
5.3.10.1	Initial conditions .....	36
5.3.10.2	Procedure .....	36
5.3.10.2.1	Procedure for narrowband blocking .....	36
5.3.10.2.2	Procedure for additional narrowband blocking for GSM/EDGE.....	36
5.3.10.2.3	Procedure for GSM/EDGE AM suppression.....	37
5.3.10.3	Test requirement .....	37
<b>Annex A (normative):</b>	<b>HS Requirements and conformance Test specifications Table (HS-RTT).....</b>	<b>38</b>
<b>Annex B (normative):</b>	<b>Base Station configurations.....</b>	<b>40</b>
B.1	Multi-carrier reception with multiple receiver antenna connectors and receiver diversity .....	40
B.2	Duplexers .....	40
B.3	Power supply options .....	40
B.4	Ancillary RF amplifiers.....	40
B.5	BS using antenna arrays .....	41
B.5.1	Receiver tests.....	41
B.5.2	Transmitter tests .....	42
B.6	Multi-carrier transmission with multiple transmitter antenna connectors, transmit diversity and MIMO transmission .....	42
B.7	BS with integrated Iuant BS modem.....	43
<b>Annex C (informative):</b>	<b>Environmental profile specification .....</b>	<b>44</b>
<b>Annex D (informative):</b>	<b>The EN title in the official languages .....</b>	<b>45</b>
<b>Annex E (informative):</b>	<b>Bibliography.....</b>	<b>46</b>
History .....		47

---

## Intellectual Property Rights

IPRs essential or potentially essential to the present document may have been declared to ETSI. The information pertaining to these essential IPRs, if any, is publicly available for **ETSI members and non-members**, and can be found in ETSI SR 000 314: *"Intellectual Property Rights (IPRs); Essential, or potentially Essential, IPRs notified to ETSI in respect of ETSI standards"*, which is available from the ETSI Secretariat. Latest updates are available on the ETSI Web server (<http://webapp.etsi.org/IPR/home.asp>).

Pursuant to the ETSI IPR Policy, no investigation, including IPR searches, has been carried out by ETSI. No guarantee can be given as to the existence of other IPRs not referenced in ETSI SR 000 314 (or the updates on the ETSI Web server) which are, or may be, or may become, essential to the present document.

---

## Foreword

This Harmonized European Standard (Telecommunications series) has been produced by ETSI Technical Committee Mobile Standards Group (MSG), and is now submitted for the Public Enquiry phase of the ETSI standards Two-step Approval Procedure.

The present document has been produced by ETSI in response to mandate M/284 from the European Commission issued under Council Directive 98/34/EC [i.1] (as amended) laying down a procedure for the provision of information in the field of technical standards and regulations.

The present document is intended to become a Harmonized Standard, the reference of which will be published in the Official Journal of the European Union referencing the Directive 1999/5/EC [i.2] of the European Parliament and of the Council of 9 March 1999 on radio equipment and telecommunications terminal equipment and the mutual recognition of their conformity ("the R&TTE Directive").

The requirements relevant to Directive 1999/5/EC [i.2] are summarised in annex A.

The present document is part 18 of a multi-part deliverable covering the Base Stations (BS), Repeaters and User Equipment (UE) for IMT-2000 Third-Generation cellular networks, as identified below:

- Part 1: "Harmonized EN for IMT-2000, introduction and common requirements, covering the essential requirements of article 3.2 of the R&TTE Directive";
- Part 2: "Harmonized EN for IMT-2000, CDMA Direct Spread (UTRA FDD and E-UTRA FDD) (UE) covering the essential requirements of article 3.2 of the R&TTE Directive";
- Part 3: "Harmonized EN for IMT-2000, CDMA Direct Spread (UTRA FDD and E-UTRA FDD) (BS) covering the essential requirements of article 3.2 of the R&TTE Directive";
- Part 4: "Harmonized EN for IMT-2000, CDMA Multi-Carrier (cdma2000) and Evolved CDMA Multi-Carrier Ultra Mobile Broadband (UMB) (UE) covering the essential requirements of article 3.2 of the R&TTE Directive";
- Part 5: "Harmonized EN for IMT-2000, CDMA Multi-Carrier (cdma2000) and Evolved CDMA Multi-Carrier Ultra Mobile Broadband (UMB) (BS) covering the essential requirements of article 3.2 of the R&TTE Directive";
- Part 6: "Harmonized EN for IMT-2000, CDMA TDD (UTRA TDD and E-UTRA TDD) (UE) covering the essential requirements of article 3.2 of the R&TTE Directive";
- Part 7: "Harmonized EN for IMT-2000, CDMA TDD (UTRA TDD and E-UTRA TDD) (BS) covering the essential requirements of article 3.2 of the R&TTE Directive";
- Part 8: "Harmonized EN for IMT-2000, TDMA Single-Carrier (UWC 136) (UE) covering essential requirements of article 3.2 of the R&TTE Directive";
- Part 9: "Harmonized EN for IMT-2000, TDMA Single-Carrier (UWC 136) (BS) covering essential requirements of article 3.2 of the R&TTE Directive";

- Part 10: "Harmonized EN for IMT-2000, FDMA/TDMA (DECT) covering essential requirements of article 3.2 of the R&TTE Directive";
- Part 11: "Harmonized EN for IMT-2000, CDMA Direct Spread (UTRA FDD and E-UTRA FDD) (Repeaters) covering the essential requirements of article 3.2 of the R&TTE Directive";
- Part 12: "Harmonized EN for IMT-2000, CDMA Multi-Carrier (cdma2000) (Repeaters) covering the essential requirements of article 3.2 of the R&TTE Directive";
- Part 13: "Harmonized EN for IMT-2000, Evolved Universal Terrestrial Radio Access (E-UTRA) (UE) covering the essential requirements of article 3.2 of the R&TTE Directive";
- Part 14: "Harmonized EN for IMT-2000, Evolved Universal Terrestrial Radio Access (E-UTRA) (BS) covering the essential requirements of article 3.2 of the R&TTE Directive";
- Part 15: "Harmonized EN for IMT-2000, Evolved Universal Terrestrial Radio Access (E-UTRA) (FDD Repeaters) covering the essential requirements of article 3.2 of the R&TTE Directive";
- Part 16: "Harmonized EN for IMT-2000, Evolved CDMA Multi-Carrier Ultra Mobile Broadband (UMB) (UE) covering the essential requirements of article 3.2 of the R&TTE Directive";
- Part 17: "Harmonized EN for IMT-2000, Evolved CDMA Multi-Carrier Ultra Mobile Broadband (UMB) (BS) covering the essential requirements of article 3.2 of the R&TTE Directive";
- Part 18: "Harmonized EN for Multi-Standard Radio (UTRA, E-UTRA, GSM/EDGE) Base Stations (BS) covering the essential requirements of article 3.2 of the R&TTE Directive";**
- Part 19: "Harmonized EN for IMT-2000 OFDMA TDD WMAN (Mobile WiMAX) TDD User Equipment (UE) covering the essential requirements of article 3.2 of the R&TTE Directive";
- Part 20: "Harmonized EN for IMT-2000, OFDMA TDD WMAN (Mobile WiMAX) TDD Base Station (BS) covering the essential requirements of article 3.2 of the R&TTE Directive";
- Part 21: "Harmonized EN for IMT-2000, OFDMA TDD WMAN (Mobile WiMAX) FDD User Equipment (UE) covering the essential requirements of article 3.2 of the R&TTE Directive";
- Part 22: "Harmonized EN for IMT-2000, OFDMA TDD WMAN (Mobile WiMAX) FDD Base Stations (BS) covering the essential requirements of article 3.2 of the R&TTE Directive".

<b>Proposed national transposition dates</b>	
Date of latest announcement of this EN (doa):	3 months after ETSI publication
Date of latest publication of new National Standard or endorsement of this EN (dop/e):	6 months after doa
Date of withdrawal of any conflicting National Standard (dow):	18 months after doa

---

## Introduction

The present document is part of a set of standards developed by ETSI and is designed to fit in a modular structure to cover all radio and telecommunications terminal equipment within the scope of the R&TTE Directive [i.2]. The modular structure is shown in EG 201 399 [i.3].

# 1 Scope

The present document applies to the following radio equipment type:

- Multi-Standard Radio capable Base stations (E-UTRA, UTRA, GSM/EDGE).

These radio equipment types are capable of operating in all or any part of the frequency bands given in table 1-1.

**Table 1-1: {Radiocommunications} service frequency bands**

Operating band and Band Category	Direction of transmission	E-UTRA Base Station operating bands
1 (BC1)	Transmit	2 110 MHz to 2 170 MHz
	Receive	1 920 MHz to 1 980 MHz
3 (BC2)	Transmit	1 805 MHz to 1 880 MHz
	Receive	1 710 MHz to 1 785 MHz
7 (BC1)	Transmit	2 620 MHz to 2 690 MHz
	Receive	2 500 MHz to 2 570 MHz
8 (BC2)	Transmit	925 MHz to 960 MHz
	Receive	880 MHz to 915 MHz
20 (BC1)	Transmit	791 MHz to 821 MHz
	Receive	832 MHz to 862 MHz
33 (BC3)	Transmit and Receive	1 900 MHz to 1 920 MHz
34 (BC3)	Transmit and Receive	2 010 MHz to 2 025 MHz
38 (BC3)	Transmit and Receive	2 570 MHz to 2 620 MHz

The present document covers requirements for multi-RAT capable E-UTRA, UTRA and GSM/EDGE MSR Base Stations for Release 9.

The present document is intended to cover the provisions of Directive 1999/5/EC [i.2] (R&TTE Directive), article 3.2, which states that "..... radio equipment shall be so constructed that it effectively uses the spectrum allocated to terrestrial/space radio communications and orbital resources so as to avoid harmful interference".

In addition to the present document, other ENs that specify technical requirements in respect of essential requirements under other parts of article 3 of the R&TTE Directive may apply to equipment within the scope of the present document.

NOTE: A list of such ENs is included on the web site <http://www.newapproach.org>.

# 2 References

References are either specific (identified by date of publication and/or edition number or version number) or non-specific. For specific references, only the cited version applies. For non-specific references, the latest version of the reference document (including any amendments) applies.

Referenced documents which are not found to be publicly available in the expected location might be found at <http://docbox.etsi.org/Reference>.

NOTE: While any hyperlinks included in this clause were valid at the time of publication ETSI cannot guarantee their long term validity.



## 2.1 Normative references

The following referenced documents are necessary for the application of the present document.

- [1] ETSI EN 301 908-1 (V5.1.1): "Electromagnetic compatibility and Radio spectrum Matters (ERM); Base Stations (BS), Repeaters and User Equipment (UE) for IMT-2000 Third-Generation cellular networks; Part 1: Harmonized EN for IMT-2000, introduction and common requirements, covering the essential requirements of article 3.2 of the R&TTE Directive".
- [2] ETSI TS 137 141 (V9.1.0): "Digital cellular telecommunications system (Phase 2+); Universal Mobile Telecommunications System (UMTS); LTE; E-UTRA, UTRA and GSM/EDGE; Multi-Standard Radio (MSR) Base Station (BS) conformance testing (3GPP TS 37.141 version 9.1.0 Release 9)".
- [3] ETSI TS 125 104 (V9.4.0): "Universal Mobile Telecommunications System (UMTS); Base Station (BS) radio transmission and reception (FDD) (3GPP TS 25.104 version 9.4.0 Release 9)".
- [4] ETSI TS 125 105 (V9.1.0): "Universal Mobile Telecommunications System (UMTS); Base Station (BS) radio transmission and reception (TDD) (3GPP TS 25.105 version 9.1.0 Release 9)".
- [5] ETSI TS 136 104 (V9.4.0): "LTE; Evolved Universal Terrestrial Radio Access (E-UTRA); Base Station (BS) radio transmission and reception (3GPP TS 36.104 version 9.4.0 Release 9)".
- [6] ETSI TS 145 005 (V9.3.0): Technical Specification, "Digital cellular telecommunications system (Phase 2+); Radio transmission and reception (3GPP TS 45.005 version 9.3.0 Release 9)".
- [7] ITU-R Recommendation SM.329-10 (2003): "Unwanted emissions in the spurious domain".
- [8] ETSI EN 301 908-3 (V5.1.1): "Base Stations (BS), Repeaters and User Equipment (UE) for IMT-2000 Third-Generation cellular networks; Part 3: Harmonized EN for IMT-2000, CDMA Direct Spread (UTRA FDD and E-UTRA FDD) (BS) covering the essential requirements of article 3.2 of the R&TTE Directive".
- [9] ETSI EN 301 908-7 (V5.1.1): "Base Stations (BS), Repeaters and User Equipment (UE) for IMT-2000 Third-Generation cellular networks Part 7: Harmonized EN for IMT-2000, CDMA TDD (UTRA TDD and E-UTRA TDD) (BS) covering the essential requirements of article 3.2 of the R&TTE Directive".
- [10] ETSI EN 301 908-14 (V5.1.1): "Electromagnetic compatibility and Radio spectrum Matters (ERM); Base Stations (BS), Repeaters and User Equipment (UE) for IMT-2000 Third-Generation cellular networks; Part 14: Harmonized EN for IMT-2000, Evolved Universal Terrestrial Radio Access (E-UTRA) (BS) covering the essential requirements of article 3.2 of the R&TTE Directive".
- [11] ETSI EN 301 502 (V9.2.0): "Global System for Mobile communications (GSM); Harmonized EN for Base Station Equipment covering the essential requirements of article 3.2 of the R&TTE Directive".
- [12] ETSI TS 137 104 (V9.3.0): "Digital cellular telecommunications system (Phase 2+); Universal Mobile Telecommunications System (UMTS); LTE; E-UTRA, UTRA and GSM/EDGE; Multi-Standard Radio (MSR) Base Station (BS) radio transmission and reception (3GPP TS 37.104 version 9.3.0 Release 9)".
- [13] ETSI TS 136 141 (V9.5.0): "LTE; Evolved Universal Terrestrial Radio Access (E-UTRA); Base Station (BS) conformance testing (3GPP TS 36.141 version 9.5.0 Release 9)".
- [14] ETSI TS 125 141 (V9.5.0): "Universal Mobile Telecommunications System (UMTS); Base Station (BS) conformance testing (FDD) (3GPP TS 25.141 version 9.5.0 Release 9)".
- [15] ETSI TS 125 142 (V9.3.0): "Universal Mobile Telecommunications System (UMTS); Base Station (BS) conformance testing (TDD) (3GPP TS 25.142 version 9.3.0 Release 9)".
- [16] ETSI TS 151 021 (V9.3.0): "Digital cellular telecommunications system (Phase 2+); Base Station System (BSS) equipment specification; Radio aspects (3GPP TS 51.021 version 9.3.0 Release 9)".

## 2.2 Informative references

The following referenced documents are not necessary for the application of the present document but they assist the user with regard to a particular subject area.

- [i.1] Directive 98/34/EC of the European Parliament and of the Council of 22 June 1998 laying down a procedure for the provision of information in the field of technical standards and regulations.
- [i.2] Directive 1999/5/EC of the European Parliament and of the Council of 9 March 1999 on radio equipment and telecommunications terminal equipment and the mutual recognition of their conformity (R&TTE Directive).
- [i.3] ETSI EG 201 399: "Electromagnetic compatibility and Radio spectrum Matters (ERM); A guide to the production of Harmonized Standards for application under the R&TTE Directive".
- [i.4] ETSI TR 102 215 (V1.3.1): "Electromagnetic compatibility and Radio spectrum Matters (ERM); Recommended approach, and possible limits for measurement uncertainty for the measurement of radiated electromagnetic fields above 1 GHz".
- [i.5] ETSI TR 100 028 (all parts) (V1.4.1): "Electromagnetic compatibility and Radio spectrum Matters (ERM); Uncertainties in the measurement of mobile radio equipment characteristics".

---

## 3 Definitions, symbols and abbreviations

### 3.1 Definitions

For the purposes of the present document, the following terms and definitions apply:

**band category:** group of operating bands for which the same MSR scenarios apply

**Base Station RF bandwidth:** bandwidth in which a Base Station transmits and receives multiple carriers and/or RATs simultaneously

**Base Station RF bandwidth edge:** frequency of one of the edges of the Base Station RF bandwidth

**carrier:** modulated waveform conveying the E-UTRA, UTRA or GSM/EDGE physical channels

**channel bandwidth:** RF bandwidth supporting a single E-UTRA RF carrier with the transmission bandwidth configured in the uplink or downlink of a cell

NOTE: The channel bandwidth is measured in MHz and is used as a reference for transmitter and receiver RF requirements.

**carrier power:** power at the antenna connector in the channel bandwidth of the carrier averaged over at least one subframe for E-UTRA, at least one slot for UTRA and the useful part of the burst for GSM/EDGE

**configured carrier power:** target maximum power for a specific carrier for the operating mode set in the BS

**downlink operating band:** part of the operating band designated for downlink

**lower RF bandwidth edge:** frequency of the lower edge of the Base Station RF bandwidth, used as a frequency reference point for transmitter and receiver requirements

**maximum carrier output power:** carrier power available at the antenna connector for a specified reference condition

**maximum throughput:** maximum achievable throughput for a reference measurement channel

**maximum total output power:** sum of the power of all carriers available at the antenna connector for a specified reference condition

**measurement bandwidth:** bandwidth in which an emission level is specified

**MSR Base Station:** Base Station characterized by the ability of its receiver and transmitter to process two or more carriers in common active RF components simultaneously in a declared RF bandwidth, where at least one carrier is of a different RAT than the other carrier(s)

**operating band:** frequency range in which E-UTRA, UTRA or GSM/EDGE operates (paired or unpaired), that is defined with a specific set of technical requirements

NOTE: The operating band(s) for a BS is declared by the manufacturer.

**throughput:** number of payload bits successfully received per second for a reference measurement channel in a specified reference condition

**transmission bandwidth:** bandwidth of an instantaneous E-UTRA transmission from a UE or BS, measured in Resource Block units

**uplink operating band:** part of the operating band designated for uplink

**upper RF bandwidth edge:** frequency of the upper edge of the Base Station RF bandwidth, used as a frequency reference point for transmitter and receiver requirements

## 3.2 Symbols

For the purposes of the present document, the following symbols apply:

$BW_{RF}$	Base Station RF bandwidth, where $BW_{RF} = F_{BW\ RF,high} - F_{BW\ RF,low}$
$f$	Frequency
$\Delta f$	Separation between the Base Station RF bandwidth edge frequency and the nominal -3dB point of the measuring filter closest to the carrier frequency
$\Delta f_{max}$	The largest value of $\Delta f$ used for defining the requirement
$F_C$	Carrier centre frequency
$F_{filter}$	Filter centre frequency
$f_{offset}$	Separation between the Base Station RF bandwidth edge frequency and the centre of the measuring filter
$f_{offset_{max}}$	The maximum value of $f_{offset}$ used for defining the requirement
$F_{BW\ RF,high}$	Upper RF bandwidth edge, where $F_{BW\ RF,high} = F_{C,high} + F_{offset, RAT}$
$F_{BW\ RF,low}$	Lower RF bandwidth edge, where $F_{BW\ RF,low} = F_{C,low} - F_{offset, RAT}$
$F_{C,high}$	Center frequency of the highest transmitted/received carrier
$F_{C,low}$	Center frequency of the lowest transmitted/received carrier
$F_{offset, RAT}$	Frequency offset from $F_{C,high}$ to the <i>upper RF bandwidth edge</i> or $F_{C,low}$ to the <i>lower RF bandwidth edge</i> for a specific RAT
$F_{UL,low}$	The lowest frequency of the uplink operating band
$F_{UL,high}$	The highest frequency of the uplink operating band
$P_{EM,N}$	Declared emission level for channel N
$P_{max}$	Maximum total output power
$P_{max,c}$	Maximum carrier output power
$P_{REFSENS}$	Reference Sensitivity power level

## 3.3 Abbreviations

For the purposes of the present document, the following abbreviations apply:

ACLR	Adjacent Channel Leakage Ratio
ARFCN	Absolute Radio Frequency Channel Number
BC	Band Category
BER	Bit Error Ratio
BS	Base Station
BTS	Base Transceiver Station
CW	Continuous Wave
DB-DC-HSDPA	Dual Band Dual Cell HSDPA
DC-HSDPA	Dual Cell HSDPA
DTT	Digital Terrestrial Television

EDGE	Enhanced Data rates for GSM Evolution
FDD	Frequency Division Duplex
FRC	Fixed Reference Channel
GSM	Global System for Mobile Communications
HSDPA	High Speed Downlink Packet Access
ITU-R	Radiocommunication Sector of the ITU
MIMO	Multiple Input Multiple Output
MS	Mobile Station
MSR	Multi-Standard Radio
RAT	Radio Access Technology
RB	Resource Block (for E-UTRA)
RF	Radio Frequency
RMS	Root Mean Square (value)
RX	Receiver
TDD	Time Division Duplex
TX	Transmitter
UARFCN	UTRA Absolute Radio Frequency Channel Number
UE	User Equipment
UEM	operating band Unwanted Emissions Mask

## 4 Technical requirements specifications

### 4.1 Environmental profile

The technical requirements of the present document apply under the environmental profile for operation of the equipment, which shall be declared by the supplier. The equipment shall comply with all the technical requirements of the present document at all times when operating within the boundary limits of the declared operational environmental profile.

For guidance on how a supplier can declare the environmental profile, see annex C.

### 4.2 Conformance requirements

The requirements in the present document are based on the assumption that the operating band (see table 1-1) is shared between systems of the IMT-2000 family (for band 3 and 8 also GSM) or systems having compatible characteristics.

#### 4.2.1 Introduction

To meet the essential requirement under article 3.2 of Directive 1999/5/EC [i.2] (R&TTE Directive) for IMT-2000 Base Stations (BS), seven essential parameters in addition to those in EN 301 908-1 [1] have been identified. Table 4.2.1-1 provides a cross reference between these seven essential parameters and the corresponding nine technical requirements for equipment within the scope of the present document.

**Table 4.2.1-1: Cross references**

Essential parameter	Corresponding technical requirements
Spectrum emissions mask	4.2.2 Operating band unwanted emissions
	4.2.3 Adjacent Channel Leakage power Ratio (ACLR)
Conducted spurious emissions from the transmitter antenna connector	4.2.4 Transmitter spurious emissions
Accuracy of maximum output power	4.2.5 Base station maximum output power
Intermodulation attenuation of the transmitter	4.2.6 Transmit intermodulation
Conducted spurious emissions from the receiver antenna connector	4.2.7 Receiver spurious emissions
Impact of interference on receiver performance	4.2.8 In-band blocking
	4.2.9 Out-of-band blocking
	4.2.10 Receiver intermodulation characteristics
Receiver adjacent channel selectivity	4.2.11 Narrowband blocking

The manufacturer shall declare the following:

- The operating band(s) supported by the Base Station according to table 1-1.
- The supported capability set(s) according to clause 4.7.1 of TS 137 141 [2].
- The supported RF configurations according to clause 4.7.2 of TS 137 141 [2].

The technical requirements in the present document apply for the declared operating band(s) as outlined for each requirement. For a Base Station supporting more than one operating band, conformance testing for each technical requirement in clause 5 shall be performed for each operating band.

All technical requirements shall apply with a frequency offset from the lowest and highest carriers to the RF bandwidth edges ( $F_{\text{offset, RAT}}$ ) that is specific for each RAT in each Band Category as specified in clause 4.4 of TS 137 141 [2].

The technical requirements also apply to the BS configurations described in annex B.

For a BS declared to support Band 20 and to operate in geographic areas within the CEPT in which frequencies are allocated to broadcasting (DTT) service, the manufacturer shall additionally declare the following quantities associated with the applicable test conditions of table 4.2.2.4-1 and information in annex G of TS 136 104 [5]:

- $P_{\text{EM,N}}$  Declared emission level for channel N.
- $P_{10\text{MHz}}$  Maximum output Power in 10 MHz.

## 4.2.2 Operating band unwanted emissions

### 4.2.2.1 Definition

Unwanted emissions consist of out-of-band emissions and spurious emissions (ITU-R Recommendation SM.329-10 [7]). Out of band emissions are emissions immediately outside the channel bandwidth resulting from the modulation process and non-linearity in the transmitter but excluding spurious emissions. Spurious emissions are emissions which are caused by unwanted transmitter effects such as harmonics emission, parasitic emission, intermodulation products and frequency conversion products, but exclude out-of-band emissions. Operating band unwanted emissions cover both out-of-band and spurious domain frequencies.

The Operating band unwanted emission limits are defined from 10 MHz below the lowest frequency of the downlink operating band to the lower RF bandwidth edge located at  $F_{\text{BW RF,low}}$  and from the upper RF bandwidth edge located at  $F_{\text{BW RF,high}}$  up to 10 MHz above the highest frequency of the downlink operating band.

The requirements shall apply whatever the type of transmitter considered (single RAT or multi-RAT, single carrier or multi-carrier) and for all transmission modes foreseen by the manufacturer's specification, except for GSM/EDGE single RAT operation. The requirements in TS 145 005 [6] as defined in clause 4.2.2.2.3 apply to an MSR Base Station for GSM/EDGE single RAT operation in Band Category 2.

### 4.2.2.2 Limits

#### 4.2.2.2.1 Limits for Band Categories 1 and 3

For a BS operating in Band Category 1 or Band Category 3, emissions shall not exceed the maximum levels specified in table 4.2.2.2.1-1, where:

- $\Delta f$  is the separation between the RF bandwidth edge frequency and the nominal -3 dB point of the measuring filter closest to the carrier frequency.
- $f_{\text{offset}}$  is the separation between the RF bandwidth edge frequency and the centre of the measuring filter.
- $f_{\text{offset}_{\text{max}}}$  is the offset to the frequency 10 MHz outside the downlink operating band.
- $\Delta f_{\text{max}}$  is equal to  $f_{\text{offset}_{\text{max}}}$  minus half of the bandwidth of the measuring filter.

Table 4.2.2.2.1-1: Operating band unwanted emission mask (UEM) for BC1 and BC3

Frequency offset of measurement filter -3 dB point, $\Delta f$	Frequency offset of measurement filter centre frequency, $f_{\text{offset}}$	Minimum requirement	Measurement bandwidth
$0 \text{ MHz} \leq \Delta f < 0,2 \text{ MHz}$	$0,015 \text{ MHz} \leq f_{\text{offset}} < 0,215 \text{ MHz}$	-12,5 dBm	30 kHz
$0,2 \text{ MHz} \leq \Delta f < 1 \text{ MHz}$	$0,215 \text{ MHz} \leq f_{\text{offset}} < 1,015 \text{ MHz}$	$-12,5 \text{ dBm} - 15 \cdot \left( \frac{f_{\text{offset}}}{\text{MHz}} - 0,215 \right) \text{ dB}$	30 kHz
(note 1)	$1,015 \text{ MHz} \leq f_{\text{offset}} < 1,5 \text{ MHz}$	-24,5 dBm	30 kHz
$1 \text{ MHz} \leq \Delta f \leq \min(\Delta f_{\text{max}}, 10 \text{ MHz})$	$1,5 \text{ MHz} \leq f_{\text{offset}} < \min(f_{\text{offset}_{\text{max}}}, 10,5 \text{ MHz})$	-11,5 dBm	1 MHz
$10 \text{ MHz} \leq \Delta f \leq \Delta f_{\text{max}}$	$10,5 \text{ MHz} \leq f_{\text{offset}} < f_{\text{offset}_{\text{max}}}$	-15 dBm (note 2)	1 MHz
NOTE 1: This frequency range ensures that the range of values of $f_{\text{offset}}$ is continuous.			
NOTE 2: The requirement is not applicable when $\Delta f_{\text{max}} < 10 \text{ MHz}$ .			

#### 4.2.2.2.2 Limits for Band Category 2

For a BS operating in Band Category 2, emissions shall not exceed the maximum levels specified in tables 4.2.2.2.2-1 and 4.2.2.2.2-2, where:

- $\Delta f$  is the separation between the RF bandwidth edge frequency and the nominal -3dB point of the measuring filter closest to the carrier frequency.
- $f_{\text{offset}}$  is the separation between the RF bandwidth edge frequency and the centre of the measuring filter.
- $f_{\text{offset}_{\text{max}}}$  is the offset to the frequency 10 MHz outside the downlink operating band.
- $\Delta f_{\text{max}}$  is equal to  $f_{\text{offset}_{\text{max}}}$  minus half of the bandwidth of the measuring filter.

Table 4.2.2.2.2-1: Operating band unwanted emission mask (UEM) for BC2

Frequency offset of measurement filter -3 dB point, $\Delta f$	Frequency offset of measurement filter centre frequency, $f_{\text{offset}}$	Minimum requirement	Measurement bandwidth
$0 \text{ MHz} \leq \Delta f < 0,2 \text{ MHz}$ (note 1)	$0,015 \text{ MHz} \leq f_{\text{offset}} < 0,215 \text{ MHz}$	-12,5 dBm	30 kHz
$0,2 \text{ MHz} \leq \Delta f < 1 \text{ MHz}$	$0,215 \text{ MHz} \leq f_{\text{offset}} < 1,015 \text{ MHz}$	$-12,5 \text{ dBm} - 15 \cdot \left( \frac{f_{\text{offset}}}{\text{MHz}} - 0,215 \right) \text{ dB}$	30 kHz
(note 2)	$1,015 \text{ MHz} \leq f_{\text{offset}} < 1,5 \text{ MHz}$	-24,5 dBm	30 kHz
$1 \text{ MHz} \leq \Delta f \leq \min(\Delta f_{\text{max}}, 10 \text{ MHz})$	$1,5 \text{ MHz} \leq f_{\text{offset}} < \min(f_{\text{offset}_{\text{max}}}, 10,5 \text{ MHz})$	-11,5 dBm	1 MHz
$10 \text{ MHz} \leq \Delta f \leq \Delta f_{\text{max}}$	$10,5 \text{ MHz} \leq f_{\text{offset}} < f_{\text{offset}_{\text{max}}}$	-15 dBm (note 3)	1 MHz
NOTE 1: For operation with a GSM/EDGE or an E-UTRA 1.4 MHz or 3 MHz carrier adjacent to the RF bandwidth edge, the limits in table 4.2.2.2.2-2 apply for $0 \text{ MHz} \leq \Delta f < 0,15 \text{ MHz}$ .			
NOTE 2: This frequency range ensures that the range of values of $f_{\text{offset}}$ is continuous.			
NOTE 3: The requirement is not applicable when $\Delta f_{\text{max}} < 10 \text{ MHz}$ .			

**Table 4.2.2.2-2: Operating band unwanted emission limits for operation in BC2 with GSM/EDGE or E-UTRA 1,4 MHz or 3 MHz carriers adjacent to the RF bandwidth edge**

Frequency offset of measurement filter -3dB point, $\Delta f$	Frequency offset of measurement filter centre frequency, $f_{\text{offset}}$	Minimum requirement	Measurement bandwidth
$0 \text{ MHz} \leq \Delta f < 0,05 \text{ MHz}$	$0,015 \text{ MHz} \leq f_{\text{offset}} < 0,065 \text{ MHz}$	$3.5 \text{ dBm} - 60 \cdot \left( \frac{f_{\text{offset}}}{\text{MHz}} - 0.015 \right) \text{ dB}$	30 kHz
$0,05 \text{ MHz} \leq \Delta f < 0,15 \text{ MHz}$	$0,065 \text{ MHz} \leq f_{\text{offset}} < 0,165 \text{ MHz}$	$0.5 \text{ dBm} - 160 \cdot \left( \frac{f_{\text{offset}}}{\text{MHz}} - 0.065 \right) \text{ dB}$	30 kHz

NOTE: The limits in this table only apply for operation with a GSM/EDGE or an E-UTRA 1,4 MHz or 3 MHz carrier adjacent to the RF bandwidth edge.

#### 4.2.2.2.3 Limits for GSM/EDGE single-RAT operation

The following test requirements and the corresponding test method specified in EN 301 502 [11] apply to an MSR Base Station for GSM/EDGE single RAT operation in Band Category 2:

- Spectrum due to the modulation and wide band noise, applicable parts of clause 4.2.4.1 of EN 301 502 [11].
- Spectrum due to switching transients, applicable parts of clause 4.2.4.2 of EN 301 502 [11].
- Emission requirement for frequency offsets of between 2 MHz and 10 MHz outside relevant transmit band, applicable parts of clause 4.2.5.2 of EN 301 502 [11].
- Intra BTS Intermodulation, applicable parts of clause 4.2.8 of EN 301 502 [11].

#### 4.2.2.2.4 Limits for protection of DTT

For a BS operating in Band 20, the level of emissions in the band 470 MHz to 790 MHz, measured in an 8 MHz filter bandwidth on centre frequencies  $F_{\text{filter}}$  according to table 4.2.2.2.4-1, shall not exceed the maximum emission level  $P_{\text{EM,N}}$  declared by the manufacturer. This requirement applies in the frequency range 470 MHz to 790 MHz even though part of the range falls in the spurious domain.

**Table 4.2.2.2.4-1: Declared emissions levels for protection of DTT**

Filter centre frequency, $F_{\text{filter}}$	Measurement bandwidth	Declared emission level [dBm]
$F_{\text{filter}} = 8 \times N + 306 \text{ (MHz)}$ ; $21 \leq N \leq 60$	8 MHz	$P_{\text{EM,N}}$

NOTE: Compliance with the declared emission levels above provides the characteristics of the base station needed to verify compliance with the corresponding CEPT/ECC technical condition using the method outlined in annex G of TS 136 104 [5].

#### 4.2.2.2.5 Limits for co-existence with services in adjacent frequency bands

The following requirement shall apply for the protection of systems operating in frequency bands adjacent to Band 1. The power of any spurious emission shall not exceed the limits specified in table 4.2.2.2.5-1.

**Table 4.2.2.2.5-1: Emissions limits for protection of adjacent band services**

Operating Band	Frequency range	Maximum Level	Measurement Bandwidth
1	2 100 MHz to 2 105 MHz	$-30 + 3,4 \cdot (f - 2 100 \text{ MHz}) \text{ dBm}$	1 MHz
	2 175 MHz to 2 180 MHz	$-30 + 3,4 \cdot (2 180 \text{ MHz} - f) \text{ dBm}$	1 MHz

### 4.2.2.3 Conformance

Conformance tests described in clause 5.3.1 shall be carried out.

## 4.2.3 Adjacent Channel Leakage power Ratio (ACLR)

### 4.2.3.1 Definition

Unwanted emissions consist of out-of-band emissions and spurious emissions (ITU-R Recommendation SM.329-10 [7]). Out of band emissions are emissions immediately outside the channel bandwidth resulting from the modulation process and non-linearity in the transmitter but excluding spurious emissions. The out-of-band emissions requirement for the BS transmitter is specified both in terms of Adjacent Channel Leakage power Ratio (ACLR) and Operating band unwanted emissions.

Adjacent Channel Leakage power Ratio (ACLR) is the ratio of the filtered mean power centred on the assigned channel frequency to the filtered mean power centred on an adjacent channel frequency. The requirement applies to frequency ranges outside the Base Station RF bandwidth.

### 4.2.3.2 Limits

#### 4.2.3.2.1 E-UTRA limits

For E-UTRA, the limits are specified in EN 301 908-14 [10], clause 4.2.3.

#### 4.2.3.2.2 UTRA FDD limits

For UTRA FDD, the limits are specified in EN 301 908-3 [8], clause 4.2.3.

#### 4.2.3.2.3 UTRA TDD limits

For UTRA TDD, the limits are specified in EN 301 908-7 [9], clause 4.2.3.

### 4.2.3.3 Conformance

Conformance tests described in clause 5.3.2 shall be carried out.

## 4.2.4 Transmitter spurious emissions

Unwanted emissions consist of out-of-band emissions and spurious emissions (ITU-R Recommendation SM.329-10 [7]). Spurious emissions are emissions which are caused by unwanted transmitter effects such as harmonics emission, parasitic emission, intermodulation products and frequency conversion products, but exclude out-of-band emissions. This is measured at the Base Station RF output port.

The transmitter spurious emission limits apply from 9 kHz to 12,75 GHz, excluding the frequency range from 10 MHz below the lowest frequency of the downlink operating band up to 10 MHz above the highest frequency of the downlink operating band.

The requirements shall apply whatever the type of transmitter considered (single carrier or multi-carrier). It applies for all transmission modes foreseen by the manufacturer's specification. Unless otherwise stated, all requirements are measured as mean power (RMS).



#### 4.2.4.1 Limits

##### 4.2.4.1.1 Spurious emissions

The power of any spurious emission shall not exceed the limits in table 4.2.4.1.1-1.

**Table 4.2.4.1.1-1: BS Spurious emissions limits**

Frequency range	Maximum Level	Measurement Bandwidth	Note
9 kHz ↔ 150 kHz	-36 dBm	1 kHz	Note 1
150 kHz ↔ 30 MHz	-36 dBm	10 kHz	Note 1
30 MHz ↔ 1 GHz	-36 dBm	100 kHz	Note 1
1 GHz ↔ 12,75 GHz	-30 dBm	1 MHz	Note 2

NOTE 1: Bandwidth as in ITU-R Recommendation SM.329 [7], section 4.1.  
 NOTE 2: Bandwidth as in ITU-R Recommendation SM.329 [7], section 4.1. Upper frequency as in ITU-R Recommendation SM.329 [7], section 2.5, table 1.

##### 4.2.4.1.2 Additional spurious emissions requirement for BC2

For a BS operating in Band Category 2 when GSM/EDGE is configured, the power of any spurious emission shall not exceed the limits in table 4.2.4.1.2-1.

**Table 4.2.4.1.2-1: Additional BS Spurious emissions limits for BC2, Category B**

Frequency range	Frequency offset from transmitter operating band edge	Maximum Level	Measurement Bandwidth
30 MHz ↔ 1 GHz	10 MHz to 20 MHz	-36 dBm	300 kHz
	20 MHz to 30 MHz	-36 dBm	1 MHz
	≥ 30 MHz	-36 dBm	3 MHz
1 GHz ↔ 12,75 GHz	≥ 30 MHz	-30 dBm	3 MHz

##### 4.2.4.1.3 Co-existence with other systems

This requirement shall be applied for the protection of UE/MS and BS/BTS receivers of other systems.

The power of any spurious emission shall not exceed the limit specified in table 4.2.4.1.3-1.

Table 4.2.4.1.3-1: Spurious emissions limits for protection of other systems

Frequency range for co-existence requirement	Maximum Level	Measurement Bandwidth	Note
921 MHz to 960 MHz	-57 dBm	100 kHz	This requirement does not apply to BS operating in band 8.
876 MHz to 915 MHz	-61 dBm	100 kHz	For the frequency range 880-915 MHz, this requirement does not apply to BS operating in band 8, since it is already covered by the requirement in clause 4.2.4.1.4.
1 805 MHz to 1 880 MHz	-47 dBm	100 kHz	This requirement does not apply to BS operating in band 3.
1 710 MHz to 1 785 MHz	-61 dBm	100 kHz	This requirement does not apply to BS operating in band 3, since it is already covered by the requirement in clause 4.2.4.1.4.
2 110 MHz to 2 170 MHz	-52 dBm	1 MHz	This requirement does not apply to BS operating in band 1.
1 920 MHz to 1 980 MHz	-49 dBm	1 MHz	This requirement does not apply to BS operating in band 1, since it is already covered by the requirement in clause 4.2.4.1.4.
1 805 MHz to 1 880 MHz	-52 dBm	1 MHz	This requirement does not apply to BS operating in band 2.
1 710 to 1 785 MHz	-49 dBm	1 MHz	This requirement does not apply to BS operating in band 2, since it is already covered by the requirement in clause 4.2.4.1.4.
2 620 MHz to 2 690 MHz	-52 dBm	1 MHz	This requirement does not apply to BS operating in band 3.
2 500 MHz to 2 570 MHz	-49 dBm	1 MHz	This requirement does not apply to BS operating in band 3, since it is already covered by the requirement in clause 4.2.4.1.4.
925 MHz to 960 MHz	-52 dBm	1 MHz	This requirement does not apply to BS operating in band 7.
880 MHz to 915 MHz	-49 dBm	1 MHz	This requirement does not apply to BS operating in band 7, since it is already covered by the requirement in clause 4.2.4.1.4.
2 600 MHz to 2 620 MHz	-52 dBm	1 MHz	This requirement does not apply to BS operating in band 8.
1 900 MHz to 1 920 MHz	-49 dBm	1 MHz	This requirement does not apply to BS operating in band 8, since it is already covered by the requirement in clause 4.2.4.1.4.
2 600 MHz to 2 620 MHz	-52 dBm	1 MHz	This requirement does not apply to BS operating in band 7 or band 38.
1 900 MHz to 1 920 MHz	-49 dBm	1 MHz	This requirement does not apply to BS operating in band 33.
2 585 MHz to 2 600 MHz	-52 dBm	1 MHz	This requirement does not apply to BS operating in band 7 or band 38.
2 010 MHz to 2 025 MHz	-49 dBm	1 MHz	This requirement does not apply to BS operating in band 34.
791 MHz to 821 MHz	-52 dBm	1 MHz	This requirement does not apply to BS operating in band 20.
832 MHz to 862 MHz	-49 dBm	1 MHz	This requirement does not apply to BS operating in band 20, since it is already covered by the requirement in clause 4.2.4.1.4.
1 900 MHz to 1 920 MHz	-52 dBm	1 MHz	This requirement does not apply to BS operating in Band 33.
2 010 MHz to 2 025 MHz	-52 dBm	1 MHz	This requirement does not apply to BS operating in Band 34.
2 570 MHz to 2 620 MHz	-52 dBm	1 MHz	This requirement does not apply to BS operating in Band 38.
NOTE 1: Where the table has two entries for the same or overlapping frequency ranges, both limits shall be applied.			
NOTE 2: As set out in the definition in clause 4.2.4.1, the co-existence requirements in this table do not apply for the 10 MHz frequency range immediately outside the downlink operating band (see table 1-1). This is also the case when the downlink operating band is adjacent to the Band for the protected system in the table.			

#### 4.2.4.1.4 Protection of the BS receiver of own or different BS

This requirement shall be applied for FDD operation in order to prevent the receivers of the Base Stations being desensitised by emissions from the BS transmitter. It is measured at the transmit antenna port for any type of BS which has common or separate Tx/Rx antenna ports.

The power of any spurious emission shall not exceed the limits in table 4.2.4.1.4-1.

**Table 4.2.4.1.4-1: BS Spurious emissions limits for protection of the BS receiver**

Band category	Frequency range	Maximum Level	Measurement Bandwidth	Note
BC1	$F_{UL\_low}$ to $F_{UL\_high}$	-96 dBm	100 kHz	
BC2	$F_{UL\_low}$ to $F_{UL\_high}$	-98 dBm	100 kHz	
NOTE: $F_{UL\_low}$ are $F_{UL\_high}$ are the lowest and highest frequency of the E-UTRA BS uplink operating band respectively.				

#### 4.2.4.2 Conformance

Conformance tests described in clause 5.3.3 shall be carried out.

### 4.2.5 Base station maximum output power

#### 4.2.5.1 Definition

Output power of the base station is the mean power delivered to a load with resistance equal to the nominal load impedance of the transmitter.

The configured carrier power is the target maximum power for a specific carrier for the operating mode set in the BS within the limits given by the manufacturer's declaration.

The maximum carrier output power,  $P_{max,c}$  of the base station is the mean power level measured at the antenna connector during the transmitter ON period for a specific carrier in a specified reference condition.

#### 4.2.5.2 Limits

In normal conditions, the maximum carrier output power shall for UTRA and E-UTRA remain within +2,7 dB and -2,7 dB of the manufacturer's rated output power and for GSM/EDGE remain within +3,0 dB and -3,0 dB of the manufacturer's rated output power.

In extreme conditions, maximum carrier output power shall for UTRA and E-UTRA remain within +3,2 dB and -3,2 dB of the manufacturer's rated output power and for GSM/EDGE remain within +3,5 dB and -3,5 dB of the manufacturer's rated output power.

#### 4.2.5.3 Conformance

Conformance tests described in clause 5.3.4 shall be carried out.

### 4.2.6 Transmit intermodulation

#### 4.2.6.1 Definition

The transmit intermodulation requirement is a measure of the capability of the transmitter to inhibit the generation of signals in its non linear elements caused by presence of the own transmit signal and an interfering signal reaching the transmitter via the antenna. The requirement applies during the transmitter ON period and the transmitter transient period.

The transmitter intermodulation level is the power of the intermodulation products when an interfering signal is injected into the antenna connector.

## 4.2.6.2 Limits

### 4.2.6.2.1 General limits

In the frequency range relevant for this test, the transmitter intermodulation level shall not exceed the unwanted emission limits in clauses 4.2.2.2, 4.2.3.2 and 4.2.4.1 in the presence of a wanted signal and an interfering signal according to table 4.2.6.2.1-1 for BS operation in BC1, BC2 and BC3. The measurement may be limited to frequencies on which third and fifth order intermodulation products appear, considering the width of these products.

**Table 4.2.6.2.1-1: Interfering signals for the Transmitter intermodulation requirement**

Parameter	Value
Interfering signal type	E-UTRA signal of channel bandwidth 5 MHz
Interfering signal level	Mean power level 30 dB below the mean power of the wanted signal
Interfering signal centre frequency offset from edge of the RF bandwidth	2,5 MHz for modulated interferer 7,5 MHz for modulated interferer 12,5 MHz for modulated interferer
NOTE:	Interfering signal positions that are partially or completely outside of the downlink operating band of the base station are excluded from the requirement, unless the interfering signal positions fall within the frequency range of adjacent downlink operating bands in the same geographical area. In case that none of the interfering signal positions fall completely within the frequency range of the downlink operating band, the test suite in clause 5.3.5 provides further guidance.

### 4.2.6.2.2 Additional limits (BC2)

In the frequency range relevant for this test, the transmitter intermodulation level shall not exceed the unwanted emission limits in clauses 4.2.2.2, 4.2.3.2 and 4.2.4.1 in the presence of a wanted signal and an interfering signal according to table 4.2.6.2.2-1 for BS operation in BC2. The measurement may be limited to frequencies on which third and fifth order intermodulation products appear, considering the width of these products.

**Table 4.2.6.2.2-1: Interfering signal for the Transmitter intermodulation requirement (BC2)**

Parameter	Value
Interfering signal type	CW
Interfering signal level	Mean power level 30 dB below the mean power of the wanted signal
Interfering signal centre frequency offset from edge of the RF bandwidth	> 800 kHz for CW interferer
NOTE:	Interfering signal positions that are partially or completely outside of the downlink operating band of the base station are excluded from the requirement.

### 4.2.6.2.3 Additional limits (BC3)

In the frequency range relevant for this test, the transmitter intermodulation level shall not exceed the unwanted emission limits in clauses 4.2.2.2, 4.2.3.2 and 4.2.4.1 in the presence of a wanted signal and an interfering signal according to table 4.2.6.2.3-1 for BS operation in BC3. The measurement may be limited to frequencies on which third and fifth order intermodulation products appear, considering the width of these products.

**Table 4.2.6.2.3-1: Interfering signals for the Transmitter intermodulation requirement (BC3)**

Parameter	Value
Interfering signal type	1,28 Mcps UTRA TDD signal of channel bandwidth 1,6 MHz
Interfering signal level	Mean power level 30 dB below the mean power of the wanted signal
Interfering signal centre frequency offset from edge of the RF bandwidth	0,8 MHz for modulated 1,28 Mcps TDD interferer 1,6 MHz for modulated 1,28 Mcps TDD interferer 2,4 MHz for modulated 1,28 Mcps TDD interferer
NOTE:	Interfering signal positions that are partially or completely outside of the downlink operating band of the base station are excluded from the requirement.

### 4.2.6.3 Conformance

Conformance tests described in clause 5.3.5 shall be carried out.

## 4.2.7 Receiver spurious emissions

### 4.2.7.1 Definition

The receiver spurious emissions power is the power of emissions generated or amplified in a receiver that appear at the BS receiver antenna connector. The requirements apply to all BS with separate RX and TX antenna ports. In this case for FDD BS the test shall be performed when both TX and RX are on, with the TX port terminated.

For TDD BS with common RX and TX antenna port the requirement applies during the Transmitter OFF period. For FDD BS with common RX and TX antenna port the transmitter spurious emission limits as specified in clause 4.2.4 are valid.

### 4.2.7.2 Limits

#### 4.2.7.2.1 General limits

The power of any spurious emission shall not exceed the levels in table 4.2.7.2.1-1.

In addition to the requirements in table 4.2.7.2.1-1, the power of any spurious emission shall not exceed the limits specified in clauses 4.2.4.1.3 and 4.2.4.1.4.

**Table 4.2.7.2.1-1: General spurious emission test requirement**

Frequency range	Maximum level	Measurement Bandwidth	Note
30 MHz to 1 GHz	-57 dBm	100 kHz	
1 GHz to 12,75 GHz	-47 dBm	1 MHz	
NOTE:	The frequency range from $F_{BW\ RF\_DL,low} - 10\text{ MHz}$ to $F_{BW\ RF\_DL,high} + 10\text{ MHz}$ may be excluded from the requirement.		

#### 4.2.7.2.2 Additional limits for BC2

For a BS operating in Band Category 2, the power of any spurious emissions shall not exceed the limits in table 4.2.7.2.2-1.

**Table 4.2.7.2.2-1: Additional BS spurious emissions limits for BC2, Category B**

Frequency range	Frequency offset from transmitter operating band edge	Maximum level	Measurement Bandwidth
30 MHz to 1 GHz	10 MHz to 20 MHz	-57 dBm	300 kHz
	20 MHz to 30 MHz	-57 dBm	1 MHz
	$\geq 30$ MHz	-57 dBm	3 MHz
1 GHz to 12,75 GHz	$\geq 30$ MHz	-47 dBm	3 MHz

### 4.2.7.3 Conformance

Conformance tests described in clause 5.3.6 shall be carried out.

## 4.2.8 In-band blocking

### 4.2.8.1 Definition

The in-band blocking characteristics is a measure of the receiver ability to receive a wanted signal at its assigned channel in the presence of an unwanted interferer inside the operating band.

### 4.2.8.2 Limits

#### 4.2.8.2.1 General limits

For the general blocking requirement, the interfering signal shall be a UTRA FDD signal as specified in clause A.1 of TS 137 141 [2].

For the wanted and interfering signal coupled to the base station antenna input, using the parameters in table 4.2.8.2.1-1, the following requirements shall be met:

- For any measured E-UTRA carrier, the throughput shall be  $\geq 95$  % of the maximum throughput of the reference measurement channel defined in TS 136 104 [5], clause 7.2.
- For any measured UTRA FDD carrier, the BER shall not exceed 0,001 for the reference measurement channel defined in TS 125 104 [3], clause 7.2.
- For any measured UTRA TDD carrier, the BER shall not exceed 0,001 for the reference measurement channel defined in TS 125 105 [4], clause 7.2.
- For any measured GSM/EDGE carrier, the conditions are specified in TS 145 005 [6], clause P.2.1.

**Table 4.2.8.2.1-1: General blocking test requirement**

Operating Band Number	Centre Frequency of Interfering Signal [MHz]	Interfering Signal mean power [dBm]	Wanted Signal mean power [dBm]	Interfering signal centre frequency minimum frequency offset from the RF bandwidth edge [MHz]
1, 3, 7, 33, 34, 38	( $F_{UL\_low} - 20$ ) to ( $F_{UL\_high} + 20$ )	-40	$P_{REFSENS} + x$ dB (see note)	$\pm 7,5$
8	( $F_{UL\_low} - 20$ ) to ( $F_{UL\_high} + 10$ )	-40	$P_{REFSENS} + x$ dB (see note)	$\pm 7,5$
20	( $F_{UL\_low} - 11$ ) to ( $F_{UL\_high} + 20$ )	-40	$P_{REFSENS} + x$ dB (see note)	$\pm 7,5$
NOTE: $P_{REFSENS}$ depends on the RAT and on the channel bandwidth, see clause 7.2 of TS 137 141 [2]. "x" is equal to 6 in case of E-UTRA or UTRA wanted signals and equal to 3 in case of GSM/EDGE wanted signal.				

#### 4.2.8.2.2 Additional BC3 blocking limits

The interfering signal is a 1,28 Mcps UTRA TDD modulated signal as specified in clause A.2 of TS 137 141 [2].

For the wanted and interfering signal coupled to the base station antenna input, using the parameters in table 4.2.8.2.2-1, the following requirements shall be met:

- For any measured E-UTRA TDD carrier, the throughput shall be  $\geq 95$  % of the maximum throughput of the reference measurement channel defined in TS 136 104 [5], clause 7.2.
- For any measured UTRA TDD carrier, the BER shall not exceed 0,001 for the reference measurement channel defined in TS 125 105 [4], clause 7.2.

**Table 4.2.8.2.2-1: Additional blocking requirement for Band Category 3**

Operating Band	Centre Frequency of Interfering Signal [MHz]	Interfering Signal mean power [dBm]	Wanted Signal mean power [dBm]	Interfering signal centre frequency minimum frequency offset from the RF bandwidth edge [MHz]
33, 34, 38	(F <sub>UL_low</sub> - 20) to (F <sub>UL_high</sub> + 20)	-40	P <sub>REFSENS</sub> + 6 dB (see note)	$\pm 2,4$

NOTE: P<sub>REFSENS</sub> depends on the RAT and on the channel bandwidth, see clause 7.2 of TS 137 141 [2].

#### 4.2.8.3 Conformance

Conformance tests described in clause 5.3.7 shall be carried out.

### 4.2.9 Out-of-band blocking

#### 4.2.9.1 Definition

The Out-of-band blocking characteristic is a measure of the receiver ability to receive a wanted signal at its assigned channel in the presence of an unwanted interferer outside the uplink operating band.

#### 4.2.9.2 Limits

The interfering signal shall be a CW carrier.

For a wanted and an interfering signal coupled to BS antenna input using the parameters in table 4.2.9.2-1, the following requirements shall be met:

- For any measured E-UTRA carrier, the throughput shall be  $\geq 95$  % of the maximum throughput of the reference measurement channel defined in TS 136 104 [5], clause 7.2.
- For any measured UTRA FDD carrier, the BER shall not exceed 0,001 for the reference measurement channel defined in TS 125 104 [3], clause 7.2.
- For any measured UTRA TDD carrier, the BER shall not exceed 0,001 for the reference measurement channel defined in TS 125 105 [4], clause 7.2.
- For any measured GSM/EDGE carrier, the conditions are specified in TS 145 005 [6], clause P.2.1.

Table 4.2.9.2-1: Blocking performance requirement

Operating Band Number	Centre Frequency of Interfering Signal [MHz]	Interfering Signal mean power [dBm]	Wanted Signal mean power [dBm]	Type of Interfering Signal
1, 3, 7, 33, 34, 38	1 to $(F_{UL\_low} - 20)$ $(F_{UL\_high} + 20)$ to 12 750	-15	$P_{REFSENS} + x$ dB (see note)	CW carrier
8	1 to $(F_{UL\_low} - 20)$ $(F_{UL\_high} + 10)$ to 12 750	-15	$P_{REFSENS} + x$ dB (see note)	CW carrier
20	1 to $(F_{UL\_low} - 11)$ $(F_{UL\_high} + 20)$ to 12 750	-15	$P_{REFSENS} + x$ dB (see note)	CW carrier
NOTE: $P_{REFSENS}$ depends on the RAT and the channel bandwidth, see clause 7.2 of TS 137 141 [2]. "x" is equal to 6 in case of E-UTRA or UTRA wanted signals and equal to 3 in case of GSM/EDGE wanted signal.				

### 4.2.9.3 Conformance

Conformance tests described in clause 5.3.8 shall be carried out.

## 4.2.10 Receiver intermodulation characteristics

### 4.2.10.1 Definition

Third and higher order mixing of the two interfering RF signals can produce an interfering signal in the band of the desired channel. Intermodulation response rejection is a measure of the capability of the receiver to receive a wanted signal on its assigned channel frequency in the presence of two interfering signals which have a specific frequency relationship to the wanted signal.

### 4.2.10.2 Limits

#### 4.2.10.2.1 General intermodulation limits

Interfering signals shall be a CW signal and an E-UTRA or UTRA signal, as specified in annex A of TS 137 141 [2].

For the wanted signal at the assigned channel frequency and two interfering signals coupled to the base station antenna input, using the parameters in tables 4.2.10.2.1-1 and 4.2.10.2.1-2, the following requirements shall be met:

- For any measured E-UTRA carrier, the throughput shall be  $\geq 95$  % of the maximum throughput of the reference measurement channel defined in TS 136 104 [5], clause 7.2.
- For any measured UTRA FDD carrier, the BER shall not exceed 0,001 for the reference measurement channel defined in TS 125 104 [3], clause 7.2.
- For any measured UTRA TDD carrier, the BER shall not exceed 0,001 for the reference measurement channel defined in TS 125 105 [4], clause 7.2.
- For any measured GSM/EDGE carrier, the conditions are specified in TS 145 005 [6], clause P.2.2.

Table 4.2.10.2.1-1: General intermodulation requirement

Mean power of interfering signals [dBm]	Wanted Signal mean power [dBm]	Type of interfering signal
-48	$P_{REFSENS} + x$ dB (see note)	See table 4.2.10.2.1-2
NOTE: $P_{REFSENS}$ depends on the RAT and on the channel bandwidth, see clause 7.2 of TS 137 141 [2]. For E-UTRA channel bandwidths 10 MHz, 15 MHz and 20 MHz this requirement shall apply only for a FRC A1-3 mapped to the frequency range at the channel edge adjacent to the interfering signals. "x" is equal to 6 in case of E-UTRA or UTRA wanted signals and equal to 3 in case of GSM/EDGE wanted signal.		



**Table 4.2.10.2.1-2: Interfering signals for intermodulation requirement**

RAT of the carrier	Interfering signal centre frequency offset from the RF bandwidth edge [MHz]	Type of interfering signal
E-UTRA 1,4 MHz	$\pm 2,0$ (BC1 and BC3) / $\pm 2,1$ (BC2)	CW
	$\pm 4,9$	1,4 MHz E-UTRA signal
E-UTRA 3 MHz	$\pm 4,4$ (BC1 and BC3) / $\pm 4,5$ (BC2)	CW
	$\pm 10,5$	3 MHz E-UTRA signal
UTRA FDD and E-UTRA 5 MHz	$\pm 7,5$	CW
	$\pm 17,5$	5 MHz E-UTRA signal
E-UTRA 10 MHz	$\pm 7,375$	CW
	$\pm 17,5$	5 MHz E-UTRA signal
E-UTRA 15 MHz	$\pm 7,25$	CW
	$\pm 17,5$	5 MHz E-UTRA signal
E-UTRA 20 MHz	$\pm 7,125$	CW
	$\pm 17,5$	5 MHz E-UTRA signal
GSM/EDGE	$\pm 7,575$	CW
	$\pm 17,5$	5 MHz E-UTRA signal
1,28 Mcps UTRA TDD	$\pm 2,3$ (BC3)	CW
	$\pm 5,6$ (BC3)	1,28 Mcps UTRA TDD signal

#### 4.2.10.2.2 General narrowband intermodulation limits

Interfering signals shall be a CW signal and an E-UTRA 1RB signal, as specified in annex A of TS 137 141 [2].

For the wanted signal at the assigned channel frequency and two interfering signals coupled to the base station antenna input, using the parameters in tables 4.2.10.2.2-1 and 4.2.10.2.2-2, the following requirements shall be met:

- For any measured E-UTRA carrier, the throughput shall be  $\geq 95$  % of the maximum throughput of the reference measurement channel defined in TS 136 104 [5], clause 7.2.
- For any measured UTRA FDD carrier, the BER shall not exceed 0,001 for the reference measurement channel defined in TS 125 104 [3], clause 7.2.
- For any measured UTRA TDD carrier, the BER shall not exceed 0,001 for the reference measurement channel defined in TS 125 105 [4], clause 7.2.
- For any measured GSM/EDGE carrier, the conditions are specified in TS 145 005 [6], clause P.2.2.

**Table 4.2.10.2.2-1: General narrowband intermodulation requirement**

Mean power of interfering signals [dBm]	Wanted Signal mean power [dBm]	Type of interfering signal
-52	$P_{\text{PREFSENS}} + x$ dB (see note)	See table 7.7.5.2-2 in TS 137 141 [2]
NOTE: $P_{\text{PREFSENS}}$ depends on the RAT and on the channel bandwidth, see clause 7.2 of TS 137 141 [2]. "x" is equal to 6 in case of E-UTRA or UTRA wanted signals and equal to 3 in case of GSM/EDGE wanted signal.		

**Table 4.2.10.2.2-2: Interfering signals for narrowband intermodulation requirement**

RAT of the carrier	Interfering signal centre frequency offset from the RF bandwidth edge [kHz]	Type of interfering signal
E-UTRA 1,4 MHz	$\pm 260$ (BC1 and BC3) / $\pm 270$ (BC2)	CW
	$\pm 970$ (BC1 and BC3) / $\pm 790$ (BC2)	1,4 MHz E-UTRA signal, 1 RB (see note 1)
E-UTRA 3 MHz	$\pm 260$ (BC1 and BC3) / $\pm 270$ (BC2)	CW
	$\pm 960$ (BC1 and BC3) / $\pm 780$ (BC2)	3,0 MHz E-UTRA signal, 1 RB (see note 1)
E-UTRA 5 MHz	$\pm 360$	CW
	$\pm 1\ 060$	5 MHz E-UTRA signal, 1 RB (see note 1)
E-UTRA 10 MHz (see note 2)	$\pm 325$	CW
	$\pm 1\ 240$	5 MHz E-UTRA signal, 1 RB (see note 1)
E-UTRA 15 MHz (see note 2)	$\pm 380$	CW
	$\pm 1\ 600$	5 MHz E-UTRA signal, 1 RB (see note 1)
E-UTRA 20 MHz (see note 2)	$\pm 345$	CW
	$\pm 1\ 780$	5 MHz E-UTRA signal, 1 RB (see note 1)
UTRA FDD	$\pm 345$ (BC1 and BC2)	CW
	$\pm 1\ 780$ (BC1 and BC2)	5 MHz E-UTRA signal, 1 RB (see note 1)
GSM/EDGE	$\pm 340$	CW
	$\pm 880$	5 MHz E-UTRA signal, 1 RB (see note 1)
1,28 Mcps UTRA TDD	$\pm 190$ (BC3)	CW
	$\pm 970$ (BC3)	1,4 MHz E-UTRA signal, 1 RB (see note 1)
NOTE 1: Interfering signal consisting of one resource block positioned at the stated offset, the channel bandwidth of the interfering signal is located adjacently to the RF bandwidth edge.		
NOTE 2: This requirement shall apply only for an E-UTRA FRC A1-3 mapped to the frequency range at the channel edge adjacent to the interfering signals.		

#### 4.2.10.2.3 Additional narrowband intermodulation limits for GSM/EDGE

The GSM/EDGE MC-BTS receiver intermodulation test requirements stated in EN 301 502 [11], applicable parts of clause 4.2.13, shall apply for GSM/EDGE carriers.

The conditions specified in TS 145 005 [6], clause P.2.2 apply for the GSM/EDGE intermodulation requirement.

#### 4.2.10.3 Conformance

Conformance tests described in clause 5.3.9 shall be carried out.

### 4.2.11 Narrowband blocking

#### 4.2.11.1 Definition

The narrowband blocking characteristics is a measure of the receiver ability to receive a wanted signal at its assigned channel in the presence of an unwanted interferer inside the operating band in the adjacent channel.

## 4.2.11.2 Limits

### 4.2.11.2.1 General limits

For the narrowband blocking requirement, the interfering signal shall be an E-UTRA 1RB signal as specified in clause A.3 of TS 137 141 [2].

For the wanted and interfering signal coupled to the base station antenna input, using the parameters in table 4.2.11.2.1-1 the following requirements shall be met:

- For any measured E-UTRA carrier, the throughput shall be  $\geq 95$  % of the maximum throughput of the reference measurement channel defined in TS 136 104 [5], clause 7.2.
- For any measured UTRA FDD carrier, the BER shall not exceed 0,001 for the reference measurement channel defined in TS 125 104 [3], clause 7.2.
- For any measured UTRA TDD carrier, the BER shall not exceed 0,001 for the reference measurement channel defined in TS 125 105 [4], clause 7.2.
- For any measured GSM/EDGE carrier, the conditions are specified in TS 145 005 [6], clause P.2.1.

**Table 4.2.11.2.1-1: Narrowband blocking requirement**

RAT of the carrier	Wanted signal mean power [dBm]	Interfering signal mean power [dBm]	Interfering RB centre frequency offset from the RF bandwidth edge [kHz]
E-UTRA, UTRA and GSM/EDGE	PREFSENS + x dB (see note 1)	-49	$\pm(240 + m \times 180)$ , m=0, 1, 2, 3, 4, 9, 14, 19, 24
NOTE 1: $P_{\text{REFSENS}}$ depends on the RAT and on the channel bandwidth, see clause 7.2 of TS 137 141 [2]. "x" is equal to 6 in case of E-UTRA or UTRA wanted signals and equal to 3 in case of GSM/EDGE wanted signal.			
NOTE 2: Interfering signal (E-UTRA 3 MHz) consisting of one resource block positioned at the stated offset, the channel bandwidth of the interfering signal is located adjacently to the RF bandwidth edge.			

### 4.2.11.2.2 Additional limits for GSM/EDGE

The GSM/EDGE in-band blocking test requirements are stated in EN 301 502 [11], applicable parts of clause 4.2.12.

The conditions specified in TS 145 005 [6], clause P.2.1 apply for GSM/EDGE in-band narrowband blocking.

### 4.2.11.2.3 GSM/EDGE limits for AM suppression

The GSM/EDGE in-band blocking test requirements are stated in EN 301 502 [11], applicable parts of clause 4.2.14.

The conditions specified in TS 145 005 [6], clause P.2.3 apply for GSM/EDGE AM suppression.

### 4.2.11.3 Conformance

Conformance tests described in clause 5.3.10 shall be carried out.

---

## 5 Testing for compliance with technical requirements

### 5.1 Environmental conditions for testing

Tests defined in the present document shall be carried out at representative points within the boundary limits of the declared operational environmental profile.

Where technical performance varies subject to environmental conditions, tests shall be carried out under a sufficient variety of environmental conditions (within the boundary limits of the declared operational environmental profile) to give confidence of compliance for the affected technical requirements.

Normally it should be sufficient for all tests to be conducted using normal test conditions except where otherwise stated. For guidance on the use of other test conditions to be used in order to show compliance reference can be made to TS 137 141 [2], annex B.

## 5.2 Interpretation of the measurement results

The interpretation of the results recorded in a test report for the measurements described in the present document shall be as follows:

- the measured value related to the corresponding limit will be used to decide whether an equipment meets the requirements of the present document;
- the value of the measurement uncertainty for the measurement of each parameter shall be included in the test report;
- the recorded value of the measurement uncertainty shall be, for each measurement, equal to or lower than the figures in table 5.2-1.

For the test methods, according to the present document, the measurement uncertainty figures shall be calculated and shall correspond to an expansion factor (coverage factor)  $k = 1,96$  (which provides a confidence level of 95 % in the case where the distributions characterising the actual measurement uncertainties are normal (Gaussian)). Principles for the calculation of measurement uncertainty are contained in TR 100 028 [i.5] or TR 102 215 [i.4].

Table 5.2-1 is based on such expansion factors.

**Table 5.2-1: Maximum measurement uncertainty**

Parameter	Condition	Uncertainty
Operating band unwanted emissions	General limits Limits for GSM/EDGE single-RAT operation Limits for protection of DTT	$\pm 1,5$ dB (note 5) $\pm 1,5$ dB
Adjacent Channel Leakage power Ratio (ACLR)	(note 4)	(note 4)
Transmitter spurious emissions	For "Spurious emissions" and "Additional spurious emissions requirement for BC2" 9 kHz < f ≤ 4 GHz 4 GHz < f ≤ 12,75 GHz For co-existence requirements (> -60 dBm) For co-existence requirements (≤ -60 dBm) For protection of the BS receiver	$\pm 2,0$ dB $\pm 4,0$ dB $\pm 2,0$ dB $\pm 3,0$ dB $\pm 3,0$ dB
Base station maximum output power	For UTRA and E-UTRA For GSM/EDGE	$\pm 0,7$ dB $\pm 1,0$ dB
Transmit intermodulation	For Operating band unwanted emissions For ACLR For "Spurious emissions" and "Additional spurious emissions requirement for BC2": f ≤ 2,2 GHz 2,2 GHz < f ≤ 4 GHz f > 4 GHz For co-existence requirements Interference signal	$\pm 2,5$ dB $\pm 2,2$ dB $\pm 2,5$ dB $\pm 2,8$ dB $\pm 4,5$ dB $\pm 2,8$ dB $\pm 1,0$ dB
Receiver spurious emissions	30 MHz ≤ f ≤ 4 GHz 4 GHz < f ≤ 12,75 GHz	$\pm 2,0$ dB $\pm 4,0$ dB
In-band blocking		$\pm 1,6$ dB
Out-of-band blocking	1 MHz < f <sub>interferer</sub> ≤ 3 GHz 3 GHz < f <sub>interferer</sub> ≤ 12,75 GHz	$\pm 1,3$ dB $\pm 3,2$ dB
Receiver intermodulation characteristics	For general and narrowband intermodulation For "Additional narrowband intermodulation limits for GSM/EDGE"	$\pm 1,8$ dB (note 5)

Parameter	Condition	Uncertainty
Narrowband blocking	For general limits For "Additional limits for GSM/EDGE" and "GSM/EDGE limits for AM suppression"	$\pm 1,4$ dB  (note 5)
<p>NOTE 1: For RF tests, it should be noted that the uncertainties in table 5.2-1 apply to the test system operating into a nominal 50 <math>\Omega</math> load and do not include system effects due to mismatch between the EUT and the Test System.</p> <p>NOTE 2: Annex G of TR 100 028-2 [i.5] provides guidance for the calculation of the uncertainty components relating to mismatch.</p> <p>NOTE 3: If the test system for a test is known to have a measurement uncertainty greater than that specified in table 5.2-1, this equipment can still be used, provided that an adjustment is made as follows: any additional uncertainty in the test system over and above that specified in table 5.2-1 is used to tighten the test requirements - making the test harder to pass (for some tests, e.g. receiver tests, this may require modification of stimulus signals). This procedure will ensure that a test system not compliant with table 5.2-1 does not increase the probability of passing an EUT that would otherwise have failed a test if a test system compliant with table 5.2-1 had been used.</p> <p>NOTE 4: The maximum measurement uncertainty for ACLR is as defined in the referenced standards EN 301 908-3 [8], EN 301 908-7 [9] and EN 301 908-14 [10].</p> <p>NOTE 5: The maximum measurement uncertainty for GSM/EDGE single-RAT requirements included by reference is as defined in EN 301 502 [11].</p>		

## 5.3 Essential radio test suites

This clause describes the test suites for MSR Base Stations.

The test configurations that shall be used for demonstrating conformance are specified in clause 5 of TS 137 141 [2]. Test configurations apply according to the declared RAT Capability Set (CS) of the Base Station and the Band Category of the declared operating band (BC1, BC2 or BC3). Transmitter test signals and test models as defined in clause 4.9.2 of TS 137 141 [2] shall be used.

Many tests in the present document are performed with the maximum RF bandwidth located at the bottom, middle and top of the supported frequency range in the operating band. These are denoted as  $B_{RFBW}$  (bottom),  $M_{RFBW}$  (middle) and  $T_{RFBW}$  (top) and are defined in clause 4.9.1 of TS 137 141 [2].

The measurement system required for each test is presented or information in TS 137 141 [2], annex D.

### 5.3.1 Operating band unwanted emissions

For the operating band unwanted emissions requirement, where the tables with test configurations in clause 5 of TS 137 141 [2] refer to single-RAT specifications, the following shall apply:

- For references to "TS 25.141", the test suite is specified in EN 301 908-3 [8], clause 5.3.1.
- For references to "TS 25.142", the test suite is specified in EN 301 908-7 [9], clause 5.3.1.1.
- For references to "TS 36.141", the test suite is specified in EN 301 908-14 [10], clause 5.3.1.

The test requirements of the present document defined in clause 4.2.2 shall apply.

For GSM/EDGE single-RAT requirements for operating band unwanted emissions, the test suite is specified in EN 301 502 [11], applicable parts of clauses 5.3.4.1, 5.3.4.2, 5.3.5.2 and 5.3.8.

For operating band unwanted emissions requirements, where the tables with test configurations in clause 5 of TS 137 141 [2] refer to the MSR test configurations defined in clause 4.8 of TS 137 141 [2], the method of test described in clauses 5.3.1.1 and 5.3.1.2 applies.

#### 5.3.1.1 Initial conditions

Test environment: normal; see clause B.2 of TS 137 141 [2].

RF bandwidth position to be tested:  $B_{RFBW}$ ,  $M_{RFBW}$  and  $T_{RFBW}$ ; see clause 4.9.1 of TS 137 141 [2].

- 1) Connect the signal analyzer to the base station RF output port as shown in clause D.1.1 of TS 137 141 [2].

As a general rule, the resolution bandwidth of the measuring equipment should be equal to the measurement bandwidth. However, to improve measurement accuracy, sensitivity, efficiency and to avoid e.g. carrier leakage, the resolution bandwidth may be smaller than the measurement bandwidth. When the resolution bandwidth is smaller than the measurement bandwidth, the result should be integrated over the measurement bandwidth in order to obtain the equivalent noise bandwidth of the measurement bandwidth.

- 2) Detection mode: True RMS.

### 5.3.1.2 Procedure

- 1) Set the base station to transmit at maximum power according to the applicable test configuration in clause 5 of TS 137 141 [2] using the corresponding test models or set of physical channels in clause 4.9.2 of TS 137 141 [2].
- 2) Step the centre frequency of the measurement filter in contiguous steps and measure the emission within the specified frequency ranges with the specified measurement bandwidth.
- 3) Repeat the test for the remaining test cases with channel set-up according to clauses 5 and 4.9.2 of TS 137 141 [2].

### 5.3.1.3 Test requirement

The results obtained shall be compared to the limits in clause 4.2.2.2 in order to prove compliance.

## 5.3.2 Adjacent Channel Leakage power Ratio (ACLR)

For the ACLR requirement, the tables with test configurations in clause 5 of TS 137 141 [2] refer to single-RAT specifications. The following shall apply:

- For references to "TS 25.141", the test suite is specified in EN 301 908-3 [8], clause 5.3.2.
- For references to "TS 25.142", the test suite is specified in EN 301 908-7 [9], clause 5.3.2.1.
- For references to "TS 36.141", the test suite is specified in EN 301 908-14 [10], clause 5.3.2.

The results obtained shall be compared to the limits in clause 4.2.3.2 in order to prove compliance.

## 5.3.3 Transmitter spurious emissions

### 5.3.3.1 Initial conditions

Test environment: normal; see clause B.2 of TS 137 141 [2].

RF bandwidth position to be tested:  $B_{\text{RFBW}}$ ,  $M_{\text{RFBW}}$  and  $T_{\text{RFBW}}$ ; see clause 4.9.1 of TS 137 141 [2].

- 1) Connect the BS antenna connector to a measurement receiver according to clause D.1.1 of TS 137 141 [2] using an attenuator or a directional coupler if necessary.
- 2) Measurements shall use a measurement bandwidth in accordance to the conditions in TS 137 104 [12], clause 6.6.1.
- 3) Detection mode: True RMS.
- 4) Configure the BS with transmitters active at their maximum total output power.

### 5.3.3.2 Procedure

- 1) Set the base station to transmit at maximum power according to the applicable test configuration in clause 5 of TS 137 141 [2] using the corresponding test models or set of physical channels in clause 4.9.2 of TS 137 141 [2].
- 2) Measure the emission at the specified frequencies with specified measurement bandwidth and note that the measured value does not exceed the specified value.

### 5.3.3.3 Test requirement

The results obtained shall be compared to the limits in clause 4.2.4.1 in order to prove compliance.

## 5.3.4 Base station maximum output power

### 5.3.4.1 Initial conditions

Test environment: normal; see clause B.2 of TS 137 141 [2].

RF bandwidth position to be tested:  $B_{RFBW}$ ,  $M_{RFBW}$  and  $T_{RFBW}$ ; see clause 4.9.1 of TS 137 141 [2].

In addition, on one ARFCN, UARFCN or E-ARFCN only, the BS output power test shall be performed under extreme power supply as defined in clause B.3 of TS 137 141 [2].

NOTE: Tests under extreme power supply also test extreme temperature.

Connect the power measuring equipment to the MSR base station antenna connector as shown in clause D.1.1 of TS 137 141 [2].

### 5.3.4.2 Procedure

- 1) Set the base station to transmit at maximum power according to the applicable test configuration in clause 5 of TS 137 141 [2] using the corresponding test models or set of physical channels in clause 4.9.2 of TS 137 141 [2].
- 2) Measure the mean power for each carrier at the base station antenna connector.

### 5.3.4.3 Test requirement

The results obtained shall be compared to the limits in clause 4.2.5.2 in order to prove compliance.

## 5.3.5 Transmit intermodulation

### 5.3.5.1 Initial conditions

Test environment: normal; see clause B.2 of TS 137 141 [2].

RF bandwidth position to be tested: according to the initial conditions specified in clauses 5.3.1, 5.3.2 and 5.3.3.

Connect the signal analyzer to the base station antenna connector as shown in clause D.1.2 of TS 137 141 [2].

### 5.3.5.2 Procedure

#### 5.3.5.2.1 General minimum requirement test procedure

- 1) Set the BS to transmit the test signal according to clause 5 of TS 137 141 [2] for requirement 5.3.3 at maximum output power according to the applicable test configuration.

- 2) Generate the interfering signal using E-TM1.1 as defined in TS 136 141 [13], clause 6.1.1.1, with 5 MHz channel bandwidth, at a centre frequency offset according to the conditions in table 6.7.1-1 in TS 137 104 [12] but exclude interference frequencies that are outside of the allocated downlink operating band.
- 3) Adjust ATT1 so that level of the E-UTRA modulated interfering signal is as defined in table 6.7.1-1 in TS 137 104 [12].
- 4) If the test signal is applicable according to clause 5 of TS 137 141 [2], perform the Out-of-band emission tests as specified in clauses 5.3.1 and 5.3.2, for all third and fifth order intermodulation products which appear in the frequency ranges defined in clauses 5.3.1 and 5.3.2. The width of the intermodulation products shall be taken into account.
- 5) If the test signal is applicable according to clause 5 of TS 137 141 [2], perform the Transmitter spurious emissions test as specified in clause 5.3.3, for all third and fifth order intermodulation products which appear in the frequency ranges defined in clause 5.3.3. The width of the intermodulation products shall be taken into account.
- 6) Verify that the emission level does not exceed the required level with the exception of interfering signal frequencies.
- 7) Repeat the test for the remaining interfering signal centre frequency offsets according to the conditions of table 6.7.1-1 in TS 137 104 [12].
- 8) Repeat the test for the remaining test signals defined in clause 5 for requirements clauses 5.3.1, 5.3.2 and 5.3.3.

NOTE: The third order intermodulation products are centred at  $2F1 \pm F2$  and  $2F2 \pm F1$ . The fifth order intermodulation products are centred at  $3F1 \pm 2F2$ ,  $3F2 \pm 2F1$ ,  $4F1 \pm F2$ , and  $4F2 \pm F1$  where  $F1$  represents the test signal centre frequency and  $F2$  represents the interfering signal centre frequency. The widths of intermodulation products are:

- $(n \times BW_{F1} + m \times 5 \text{ MHz})$  for the  $nF1 \pm mF2$  products
- $(n \times 5 \text{ MHz} + m \times BW_{F1})$  for the  $nF2 \pm mF1$  products

where  $BW_{F1}$  represents the test signal RF bandwidth, or channel bandwidth in case of single carrier .

#### 5.3.5.2.2 Additional minimum requirement (BC2) test procedure

- 1) Set the BS to transmit the test signal according to clause 5 of TS 137 141 [2] for requirement clause 5.3.3 at maximum output power according to the applicable test configuration.
- 2) Generate a CW signal as the interfering signal with a centre frequency offset of 0,8 MHz, but exclude interference frequencies that are outside of the allocated downlink operating band.
- 3) Adjust ATT1 so that level of the interfering signal is as defined in table 6.7.2-1 in TS 137 104 [12].
- 4) If the test signal is applicable according to clause 5 of TS 137 141 [2], perform the Out-of-band emission tests as specified in clauses 5.3.1 and 5.3.2, for all third and fifth order intermodulation products which appear in the frequency ranges defined in clauses 5.3.1 and 5.3.2.
- 5) If the test signal is applicable according to clause 5 of TS 137 141 [2], perform the Transmitter spurious emissions test as specified in clause 5.3.3, for all third and fifth order intermodulation products which appear in the frequency ranges defined in clause 5.3.3.
- 6) Verify that the emission level does not exceed the required level with the exception of interfering signal frequencies.
- 7) Repeat the test for interfering signal centre frequency offsets of 2,0 MHz, 3,2 MHz and 6,2 MHz.
- 8) Repeat the test for the remaining test signals defined in clause 5 of TS 137 141 [2] for requirements 5.3.1, 5.3.2 and 5.3.3.



NOTE: The third order intermodulation products are centred at  $2F1 \pm F2$  and  $2F2 \pm F1$ . The fifth order intermodulation products are centred at  $3F1 \pm 2F2$ ,  $3F2 \pm 2F1$ ,  $4F1 \pm F2$ , and  $4F2 \pm F1$  where  $F1$  represents the test signal centre frequency and  $F2$  represents the interfering signal centre frequency. The widths of intermodulation products are:

- $(n \times BW_{F1})$  for the  $nF1 \pm mF2$  products
- $(m \times BW_{F1})$  for the  $nF2 \pm mF1$  products

where  $BW_{F1}$  represents the test signal RF bandwidth or channel bandwidth in case of single carrier.

### 5.3.5.2.3 Additional minimum requirement (BC3) test procedure

- 1) Set the BS to transmit the test signal according to clause 5 of TS 137 141 [2] for requirement 5.3.3 at maximum output power according to the applicable test configuration.
- 2) Generate the interfering signal according to table 6.38A in TS 125 142 [15] at a centre frequency offset according to the conditions in table 6.7.3-1 in TS 37.104 [12], but exclude interference frequencies that are outside of the allocated downlink operating band.
- 3) Adjust ATT1 so that level of the modulated interfering signal is as defined in table 6.7.3-1 in TS 137 104 [12].
- 4) If the test signal is applicable according to clause 5 of TS 137 141 [2], perform the Out-of-band emission tests as specified in clauses 5.3.1 and 5.3.2, for all third and fifth order intermodulation products which appear in the frequency ranges defined in clauses 5.3.1 and 5.3.2. The width of the intermodulation products shall be taken into account.
- 5) If the test signal is applicable according to clause 5 of TS 137 141 [2], perform the Transmitter spurious emissions test as specified in clause 5.3.3 for all third and fifth order intermodulation products which appear in the frequency ranges defined in clause 5.3.3. The width of the intermodulation products shall be taken into account.
- 6) Verify that the emission level does not exceed the required level with the exception of interfering signal frequencies.
- 7) Repeat the test for the remaining interfering signal centre frequency offsets according to the conditions of table 6.7.3-1 in TS 137 104 [12].
- 8) Repeat the test for the remaining test models and physical channels in table 4.9.2-1.

NOTE: The third order intermodulation products are centred at  $2F1 \pm F2$  and  $2F2 \pm F1$ . The fifth order intermodulation products are centred at  $3F1 \pm 2F2$ ,  $3F2 \pm 2F1$ ,  $4F1 \pm F2$ , and  $4F2 \pm F1$  where  $F1$  represents the test signal centre frequency and  $F2$  represents the interfering signal centre frequency. The widths of intermodulation products are

- $(n \times BW_{F1} + m \times 1,6 \text{ MHz})$  for the  $nF1 \pm mF2$  products
- $(n \times 1,6 \text{ MHz} + m \times BW_{F1})$  for the  $nF2 \pm mF1$  products

where  $BW_{F1}$  represents the test signal RF bandwidth or channel bandwidth in case of single carrier .

### 5.3.5.3 Test requirement

The results obtained shall be compared to the limits in clause 4.2.6.2 in order to prove compliance.

## 5.3.6 Receiver spurious emissions

### 5.3.6.1 Initial conditions

Test environment: Normal; see clause B.2 of TS 137 141 [2].

RF bandwidth position to be tested:  $M_{RFBW}$ , see clause 4.9.1 of TS 137 141 [2].

- 1) Set up the equipment as shown in clause D.2.1 of TS 137 141 [2].

### 5.3.6.2 Procedure

- 1) Set the measurement equipment parameters as specified in table 4.2.7.2.1-1. For BC2, the parameters in table 4.2.7.2.1-2 apply in addition.
- 2) Start BS transmission according to the applicable test configuration in clause 4.8 of TS 137 141 [2] at P<sub>max</sub>.
- 3) Measure the spurious emissions over each frequency range described in clause 4.2.7.2.

### 5.3.6.3 Test requirement

The results obtained shall be compared to the limits in clause 4.2.7.2 in order to prove compliance.

## 5.3.7 In-band blocking

### 5.3.7.1 Initial conditions

Test environment: Normal; see clause B.2 of TS 137 141 [2].

RF bandwidth position to be tested:  $M_{\text{RFBW}}$ , see clause 4.9.1 of TS 137 141 [2].

- 1) Set up the equipment as shown in clause D.2.1 of TS 137 141 [2].
- 2) Start to transmit according to applicable reference measurement channel to the BS under test as follows:
  - For E-UTRA see clause A.1 in TS 136 141 [13].
  - For UTRA FDD see clause A.2 in TS 125 141 [14].
  - For UTRA TDD see clause A.2.1 in TS 125 142 [15].
  - For GSM see clause 5.3.12 in EN 301 502 [11] and annex P in TS 145 005 [6] for reference channels to test.

### 5.3.7.2 Procedure

#### 5.3.7.2.1 Procedure for general blocking

- 1) Adjust the signal generators to the type of interfering signal, levels and the frequency offsets as specified in table 4.2.8.2.1-1.
- 2) The interfering signal shall be swept with a step size of 1 MHz starting from the minimum offset to the channel edges of the wanted signals as specified in table 4.2.8.2.1-1.
- 3) Measure the performance of the wanted signal at the BS receiver, as defined in clause 4.2.8.2.1, for the relevant carriers specified by the test configuration in clause 4.8 of TS 137 141 [2].

#### 5.3.7.2.2 Procedure for additional BC3 blocking requirement

- 1) Adjust the signal generators to the type of interfering signal, levels and the frequency offsets as specified in table 4.2.8.2.2-1.
- 2) Measure the performance of the wanted signal at the BS receiver, as defined in clause 4.2.8.2.2, for the relevant carriers specified by the test configuration in clause 4.8 of TS 137 141 [2].

### 5.3.7.3 Test requirement

The results obtained shall be compared to the limits in clause 4.2.8.2 in order to prove compliance.

## 5.3.8 Out-of-band blocking

### 5.3.8.1 Initial conditions

Test environment: normal; see clause B.2 of TS 137 141 [2].

RF bandwidth position to be tested:  $M_{\text{RFBW}}$  see clause 4.9.1 of TS 137 141 [2].

- 1) Set up the equipment as shown in clause D.2.1 of TS 137 141 [2].
- 2) Start to transmit according to reference measurement channel to the BS under test as follows:
  - For E-UTRA see clause A.1 in TS 136 141 [13].
  - For UTRA FDD see clause A.2 in TS 125 141 [14].
  - For UTRA TDD see clause A.2.1 in TS 125 142 [15].
  - For GSM see clause 5.3.12 in EN 301 502 [11] and annex P in TS 145 005 [6] for reference channels to test.

### 5.3.8.2 Procedure

- 1) Adjust the signal generators to the type of interfering signals, levels and the frequency offsets as specified for test requirements in table 4.2.9.2-1.
- 2) The CW interfering signal shall be swept with a step size of 1 MHz within the specified range.
- 3) Measure the performance of the wanted signal at the BS receiver, as defined in the clause 4.2.9.2, for the relevant carriers specified by the test configuration in clause 4.8 of TS 137 141 [2].

### 5.3.8.3 Test requirement

The results obtained shall be compared to the limits in clause 4.2.9.2 in order to prove compliance.

## 5.3.9 Receiver intermodulation characteristics

### 5.3.9.1 Initial conditions

Test environment: Normal; see clause B.2 of TS 137 141 [2].

RF bandwidth position to be tested:  $M_{\text{RFBW}}$  if TC6 is applicable;  $B_{\text{RFBW}}$  and  $T_{\text{RFBW}}$  for other TC, see clause 4.9.1 of TS 137 141 [2].

- 1) Set-up the measurement system as shown in clause D.2.3 of TS 137 141 [2].
- 2) Start to transmit according to reference measurement channel to the BS under test as follows:
  - For E-UTRA see clause A.1 in TS 136 141 [13].
  - For UTRA FDD see clause A.2 in TS 125 141 [14].
  - For UTRA TDD see clause A.2.1 in TS 125 142 [15].
  - For GSM see clause 5.3.12 in EN 301 502 [11] and annex P in TS 145 005 [6] for reference channels to test.

## 5.3.9.2 Procedure

### 5.3.9.2.1 Procedure for general and narrowband intermodulation

- 1) Adjust the signal generators to the type of interfering signals, levels and the frequency offsets as specified in table 4.2.10.2.1-1 and table 4.2.10.2.1-2 for the general intermodulation requirement, and table 4.2.10.2.2-1 and table 4.2.10.2.2-2 for the narrowband intermodulation requirement.
- 2) Measure the performance of the wanted signal at the BS receiver, as defined in clause 4.2.10.2.1 and clause 4.2.10.2.2, for the relevant carriers specified by the test configuration in clause 4.8 of TS 137 141 [2].

### 5.3.9.2.2 Procedure for additional narrowband intermodulation for GSM/EDGE

The GSM/EDGE MC-BTS receiver intermodulation method of test is stated in EN 301 502 [11] applicable parts of clause 5.3.13, shall apply for GSM/EDGE carriers.

The conditions specified in TS 145 005 [6], clause P.2.2 apply for the GSM/EDGE intermodulation requirement.

## 5.3.9.3 Test requirement

The results obtained shall be compared to the limits in clause 4.2.10.2 in order to prove compliance.

## 5.3.10 Narrowband blocking

### 5.3.10.1 Initial conditions

Test environment: Normal; see clause B.2 of TS 137 141 [2].

RF bandwidth position to be tested:  $M_{\text{RFBW}}$ , see clause 4.9.1 of TS 137 141 [2].

- 1) Set up the equipment as shown in clause D.2.1 of TS 137 141 [2].
- 2) Start to transmit according to applicable reference measurement channel to the BS under test as follows:
  - For E-UTRA see clause A.1 in TS 136 141 [13].
  - For UTRA FDD see clause A.2 in TS 125 141 [14].
  - For UTRA TDD see clause A.2.1 in TS 125 142 [15].
  - For GSM see 5.3.12 in EN 301 502 [11] and annex P in TS 145 005 [6] for reference channels to test.

### 5.3.10.2 Procedure

#### 5.3.10.2.1 Procedure for narrowband blocking

- 1) Adjust the signal generators to the type of interfering signal, levels and the frequency offsets as specified in table 4.2.11.2.1-1.
- 2) Set-up and sweep the interfering RB centre frequency offset to the channel edge of the wanted signal according to table 4.2.11.2.1-1.
- 3) Measure the performance of the wanted signal at the BS receiver, as defined in clause 7.4.5, for the relevant carriers specified by the test configuration in clause 4.8 of TS 137 141 [2].

#### 5.3.10.2.2 Procedure for additional narrowband blocking for GSM/EDGE

The GSM/EDGE in-band blocking method of test is stated in TS 151 021 [16], applicable parts of clause 5.3.12.

The conditions specified in TS 145 005 [6], clause P.2.1 apply for GSM/EDGE in-band narrowband blocking.

### 5.3.10.2.3 Procedure for GSM/EDGE AM suppression

The GSM/EDGE in-band blocking method of test is stated in TS 151 021 [16], applicable parts of clause 5.3.14.

The conditions specified in TS 145 005 [6], clause P.2.3 apply for GSM/EDGE AM suppression.

### 5.3.10.3 Test requirement

The results obtained shall be compared to the limits in clause 4.2.11.2 in order to prove compliance.

## Annex A (normative): HS Requirements and conformance Test specifications Table (HS-RTT)

The HS Requirements and conformance Test specifications Table (HS-RTT) in table A.1 serves a number of purposes, as follows:

- it provides a statement of all the requirements in words and by cross reference to (a) specific clause(s) in the present document or to (a) specific clause(s) in (a) specific referenced document(s);
- it provides a statement of all the test procedures corresponding to those requirements by cross reference to (a) specific clause(s) in the present document or to (a) specific clause(s) in (a) specific referenced document(s);
- it qualifies each requirement to be either:
  - Unconditional: meaning that the requirement applies in all circumstances; or
  - Conditional: meaning that the requirement is dependent on the manufacturer having chosen to support optional functionality defined within the schedule.
- in the case of Conditional requirements, it associates the requirement with the particular optional service or functionality;
- it qualifies each test procedure to be either:
  - Essential: meaning that it is included with the Essential Radio Test Suite and therefore the requirement shall be demonstrated to be met in accordance with the referenced procedures;
  - Other: meaning that the test procedure is illustrative but other means of demonstrating compliance with the requirement are permitted.

**Table A.1: HS Requirements and conformance Test specifications Table (HS-RTT)**

<b>Harmonized Standard EN 301 908-18</b>						
The following requirements and test specifications are relevant to the presumption of conformity under the article 3.2 of the R&TTE Directive						
<b>Requirement</b>			<b>Requirement Conditionality</b>		<b>Test Specification</b>	
<b>No</b>	<b>Description</b>	<b>Reference: Clause No</b>	<b>U/C</b>	<b>Condition</b>	<b>E/O</b>	<b>Reference: Clause No</b>
1	Operating band unwanted emissions	4.2.2	U		E	5.3.1
2	Adjacent Channel Leakage power Ratio (ACLR)	4.2.3	U		E	5.3.2
3	Transmitter spurious emissions	4.2.4	U		E	5.3.3
4	Base station maximum output power	4.2.5	U		E	5.3.4
5	Transmit intermodulation	4.2.6	U		E	5.3.5
6	Receiver spurious emissions	4.2.7	U		E	5.3.6
7	In-band blocking	4.2.8	U		E	5.3.7
8	Out-of-band blocking	4.2.9	U		E	5.3.8
9	Receiver intermodulation characteristics	4.2.10	U		E	5.3.9
10	Narrowband blocking	4.2.11	U		E	5.3.10

**Key to columns:****Requirement:**

**No** A unique identifier for one row of the table which may be used to identify a requirement or its test specification.

**Description** A textual reference to the requirement.

**Clause Number** Identification of clause(s) defining the requirement in the present document unless another document is referenced explicitly.

**Requirement Conditionality:**

**U/C** Indicates whether the requirement is to be *unconditionally* applicable (U) or is *conditional* upon the manufacturers claimed functionality of the equipment (C).

**Condition** Explains the conditions when the requirement shall or shall not be applicable for a technical requirement which is classified "conditional".

**Test Specification:**

**E/O** Indicates whether the test specification forms part of the Essential Radio Test Suite (E) or whether it is one of the Other Test Suite (O).

**NOTE:** All tests whether "E" or "O" are relevant to the requirements. Rows designated "E" collectively make up the Essential Radio Test Suite; those designated "O" make up the Other Test Suite; for those designated "X" there is no test specified corresponding to the requirement. The completion of all tests classified "E" as specified with satisfactory outcomes is a necessary condition for a presumption of conformity. Compliance with requirements associated with tests classified "O" or "X" is a necessary condition for presumption of conformity, although conformance with the requirement may be claimed by an equivalent test or by manufacturer's assertion supported by appropriate entries in the technical construction file.

**Clause Number** Identification of clause(s) defining the test specification in the present document unless another document is referenced explicitly. Where no test is specified (that is, where the previous field is "X") this field remains blank.

---

## Annex B (normative): Base Station configurations

### B.1 Multi-carrier reception with multiple receiver antenna connectors and receiver diversity

For the tests in clause 5, the requirement applies at each receiver antenna connector for receivers with antenna diversity or in the case of multi-carrier reception with multiple receiver antenna connectors.

Receiver requirements are tested at the antenna connector, with the remaining receiver(s) disabled or their antenna connector(s) being terminated. If the manufacturer has declared the receiver paths to be equivalent, it is sufficient to apply the specified test signal at any one of the receiver antenna connectors.

---

### B.2 Duplexers

The requirements of the present document shall be met with a duplexer fitted, if a duplexer is supplied as part of the BS.

---

### B.3 Power supply options

If the BS is supplied with a number of different power supply configurations, it may not be necessary to test RF parameters for each of the power supply options, provided that it can be demonstrated that the range of conditions over which the equipment is tested is at least as great as the range of conditions due to any of the power supply configurations.

This applies particularly if a BS contains a DC rail which can be supplied either externally or from an internal mains power supply. In this case, the conditions of extreme power supply for the mains power supply options can be tested by testing only the external DC supply option. The range of DC input voltages for the test should be sufficient to verify the performance with any of the power supplies, over its range of operating conditions within the BS, including variation of mains input voltage, temperature and output current.

---

### B.4 Ancillary RF amplifiers

The requirements of the present document shall be met with the ancillary RF amplifier fitted. At tests according to clauses 5, the ancillary amplifier is connected to the BS by a connecting network (including any cable(s), attenuator(s), etc.) with applicable loss to make sure the appropriate operating conditions of the ancillary amplifier and the BS. The applicable connecting network loss range is declared by the manufacturer. Other characteristics and the temperature dependence of the attenuation of the connecting network are neglected. The actual attenuation value of the connecting network is chosen for each test as one of the applicable extreme values. The lowest value is used unless otherwise stated.

Sufficient tests should be repeated with the ancillary amplifier fitted and, if it is optional, without the ancillary RF amplifier to verify that the BS meets the requirements of the present document in both cases.

When testing, the following tests shall be repeated with the optional ancillary amplifier fitted according to table B.4-1, where x denotes that the test is applicable.



**Table B.4-1: Tests applicable to Ancillary RF Amplifiers**

	Clause	TX amplifier only	RX amplifier only	TX/RX amplifiers combined (see note)
<b>Receiver Tests</b>	5.3.6		X	X
	5.3.7		X	X
	5.3.8		X	X
	5.3.9		X	
<b>Transmitter Tests</b>	5.3.1	X		X
	5.3.2	X		X
	5.3.3	X		X
	5.3.4	X		X
	5.3.5	X		X
NOTE: Combining can be by duplex filters or any other network. The amplifiers can either be in RX or TX branch or in both. Either one of these amplifiers could be a passive network.				

In test according to clauses 5.3.4 highest applicable attenuation value is applied.

## B.5 BS using antenna arrays

A BS may be configured with a multiple antenna port connection for some or all of its transceivers or with an antenna array related to one cell (not one array per transceiver). This clause applies to a BS which meets at least one of the following conditions:

- the transmitter output signals from one or more transceiver appear at more than one antenna port; or
- there is more than one receiver antenna port for a transceiver or per cell and an input signal is required at more than one port for the correct operation of the receiver thus the outputs from the transmitters as well as the inputs to the receivers are directly connected to several antennas (known as "aircombining"); or
- transmitters and receivers are connected via duplexers to more than one antenna.

In case of diversity or spatial multiplexing, multiple antennas are not considered as an antenna array.

If a BS is used, in normal operation, in conjunction with an antenna system which contains filters or active elements which are necessary to meet the E-UTRA requirements, the conformance tests may be performed on a system comprising the BS together with these elements, supplied separately for the purposes of testing. In this case, it must be demonstrated that the performance of the configuration under test is representative of the system in normal operation, and the conformance assessment is only applicable when the BS is used with the antenna system.

For conformance testing of such a BS, the following procedure may be used.

### B.5.1 Receiver tests

For each test, the test signals applied to the receiver antenna connectors shall be such that the sum of the powers of the signals applied equals the power of the test signal(s) specified in the test.

An example of a suitable test configuration is shown in figure B.5.1-1.

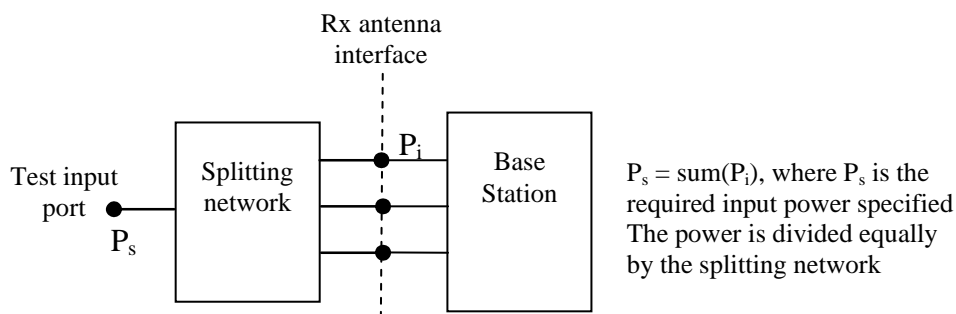

**Figure B.5.1-1: Receiver test set-up**

For spurious emissions from the receiver antenna connector, the test may be performed separately for each receiver antenna connector.

## B.5.2 Transmitter tests

For each test, the test signals applied to the transmitter antenna connectors ( $P_i$ ) shall be such that the sum of the powers of the signals applied equals the power of the test signal(s) ( $P_s$ ) specified in the test. This may be assessed by separately measuring the signals emitted by each antenna connector and summing the results, or by combining the signals and performing a single measurement. The characteristics (e.g. amplitude and phase) of the combining network should be such that the power of the combined signal is maximised.

An example of a suitable test configuration is shown in figure B.5.2-1.

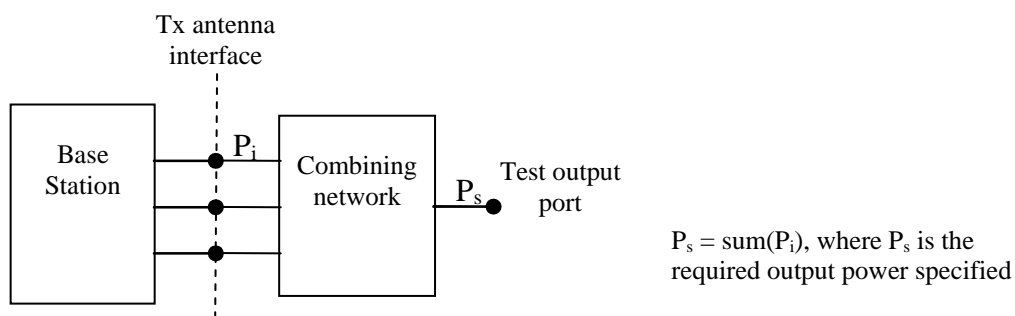

**Figure B.5.2-1: Transmitter test set-up**

For Intermodulation attenuation, the test may be performed separately for each transmitter antenna connector.

## B.6 Multi-carrier transmission with multiple transmitter antenna connectors, transmit diversity and MIMO transmission

Unless otherwise stated, for the tests in clause 5, the requirement applies for each transmitter antenna connector in case of multi-carrier transmission with multiple transmitter antenna connectors, transmit diversity, DB-DC-HSDPA or MIMO transmission.

Transmitter requirements are tested at the antenna connector, with the remaining antenna connector(s) being terminated. If the manufacturer has declared the transmitter paths to be equivalent, it is sufficient to measure the signal at any one of the transmitter antenna connectors.

---

## B.7 BS with integrated Iuant BS modem

Unless otherwise stated, for the tests in the present document, the integrated Iuant BS modem shall be switched off. Spurious emissions according to clauses 5.3.3 and 5.3.6 shall be measured only for frequencies above 20 MHz with the integrated Iuant BS modem switched on.

---

## Annex C (informative): Environmental profile specification

The following environmental conditions may be declared by the supplier:

- barometric pressure: minimum and maximum;
- temperature: minimum and maximum;
- relative humidity: minimum and maximum;
- power supply: lower and upper voltage limit.

When operating outside the boundary limits of the declared operational environmental profile the equipment should not make ineffective use of the radio frequency spectrum so as to cause harmful interference.

---

## Annex D (informative): The EN title in the official languages

The enlargement of the European Union (EU) resulted in a requirement from the EU for a larger number of languages for the translation of the titles of Harmonized Standards and mandated ENs that are to be listed in the Official Journal to support the implementation of this legislation.

For this reason the title translation concerning the present document can be consulted via the [e-approval](#) application.

---

## Annex E (informative): Bibliography

- Directive 2004/108/EC of the European Parliament and of the Council of 15 December 2004 on the approximation of the laws of the Member States relating to electromagnetic compatibility and repealing Directive 89/336/EEC (EMC Directive).
- Directive 2006/95/EC of the European Parliament and of the Council of 12 December 2006 on the harmonisation of the laws of Member States relating to electrical equipment designed for use within certain voltage limits (LV Directive).
- CEPT/ERC/REC 74-01 (Siófok 1998, Nice 1999, Sesimbra 2002, Hradec Kralove 2005): "Unwanted Emissions in the Spurious Domain".

---

## History

<b>Document history</b>		
V5.1.1	October 2010	Public Enquiry PE 20110224: 2010-10-27 to 2011-02-24