

Draft **ETSI EN 301 908-16** V4.1.1 (2009-04)

Harmonized European Standard (Telecommunications series)

**Electromagnetic compatibility
and Radio spectrum Matters (ERM);
Base Stations (BS), Repeaters and User Equipment (UE)
for IMT-2000 Third-Generation cellular networks;
Part 16: Harmonized EN for IMT-2000,
Evolved CDMA Multi-Carrier Ultra Mobile Broadband (UMB) (UE)
covering the essential requirements of article 3.2
of the R&TTE Directive**



Reference

DEN/ERM-TFES-002-16

Keywords

3G, 3GPP2, cdma2000, cellular, digital,
IMT-2000, mobile, radio, regulation, UMTS

ETSI

650 Route des Lucioles
F-06921 Sophia Antipolis Cedex - FRANCE

Tel.: +33 4 92 94 42 00 Fax: +33 4 93 65 47 16

Siret N° 348 623 562 00017 - NAF 742 C
Association à but non lucratif enregistrée à la
Sous-Préfecture de Grasse (06) N° 7803/88

Important notice

Individual copies of the present document can be downloaded from:

<http://www.etsi.org>

The present document may be made available in more than one electronic version or in print. In any case of existing or perceived difference in contents between such versions, the reference version is the Portable Document Format (PDF). In case of dispute, the reference shall be the printing on ETSI printers of the PDF version kept on a specific network drive within ETSI Secretariat.

Users of the present document should be aware that the document may be subject to revision or change of status. Information on the current status of this and other ETSI documents is available at

<http://portal.etsi.org/tb/status/status.asp>

If you find errors in the present document, please send your comment to one of the following services:

http://portal.etsi.org/chaicor/ETSI_support.asp

Copyright Notification

No part may be reproduced except as authorized by written permission.
The copyright and the foregoing restriction extend to reproduction in all media.

© European Telecommunications Standards Institute 2009.
All rights reserved.

DECT™, **PLUGTESTS™**, **UMTS™**, **TIPHON™**, the TIPHON logo and the ETSI logo are Trade Marks of ETSI registered for the benefit of its Members.

3GPP™ is a Trade Mark of ETSI registered for the benefit of its Members and of the 3GPP Organizational Partners.

LTE™ is a Trade Mark of ETSI currently being registered

for the benefit of its Members and of the 3GPP Organizational Partners.

GSM® and the GSM logo are Trade Marks registered and owned by the GSM Association.

Contents

Intellectual Property Rights	5
Foreword.....	5
Introduction	6
1 Scope	7
2 References	7
2.1 Normative references	8
2.2 Informative references.....	8
3 Definitions, symbols and abbreviations	8
3.1 Definitions	8
3.2 Symbols.....	10
3.3 Abbreviations	11
4 Technical requirements specifications	11
4.1 Environmental profile.....	11
4.2 Conformance requirements	11
4.2.1 Introduction.....	12
4.2.2 Conducted spurious emissions when transmitting	12
4.2.2.1 Definition	12
4.2.2.2 Limits	12
4.2.2.3 Conformance.....	14
4.2.3 Transmitter maximum output power.....	14
4.2.3.1 Definition	14
4.2.3.2 Limits	14
4.2.3.3 Conformance.....	14
4.2.4 Minimum controlled output power	14
4.2.4.1 Definition	14
4.2.4.2 Limits	14
4.2.4.3 Conformance.....	14
4.2.5 Conducted spurious emissions when not transmitting	14
4.2.5.1 Definition	14
4.2.5.2 Limits	15
4.2.5.3 Conformance.....	15
4.2.6 Receiver Blocking characteristics.....	15
4.2.6.1 Definition	15
4.2.6.2 Limits	15
4.2.6.3 Conformance.....	17
4.2.7 Intermodulation spurious response attenuation.....	17
4.2.7.1 Definition	17
4.2.7.2 Limits	17
4.2.7.3 Conformance.....	18
4.2.8 Receiver Adjacent Channel Selectivity (ACS)	18
4.2.8.1 Definition	18
4.2.8.2 Limits	18
4.2.8.3 Conformance.....	19
5 Testing for compliance with technical requirements.....	19
5.1 Environmental conditions for testing	19
5.2 Interpretation of the measurement results	19
5.3 Essential radio test suites.....	20
5.3.1 Conducted spurious emissions when transmitting	20
5.3.2 Transmitter maximum output power.....	20
5.3.3 Minimum controlled output power	21
5.3.4 Conducted spurious emissions when not transmitting	21
5.3.5 Receiver Blocking characteristics.....	21
5.3.6 Intermodulation spurious response attenuation.....	22

5.3.7	Receiver Adjacent Channel Selectivity (ACS)	22
Annex A (normative):	HS Requirements and conformance Test specifications Table (HS-RTT).....	24
Annex B (normative):	Mobile Station configurations.....	26
B.1	Transmission configurations	26
B.2	Common Procedures	26
B.2.1	MAC and Physical Layer Configuration	26
B.2.2	Forward and Reverse Channels and Link Assignment Block (LAB) Assignments	26
B.2.2.1	Forward Link PER Measurement Test.....	26
B.2.2.2	Emissions Test	27
B.2.3	Session and Test Application Configurations.....	27
B.2.3.1	Forward Link PER Measurement	27
B.2.3.2	Emissions Test	27
Annex C (normative):	Environmental profile	28
C.1	Introduction	28
C.2	Temperature and Power Supply Voltage.....	28
C.3	High Humidity.....	28
C.4	Vibration Stability	28
C.5	Shock Stability	28
Annex D (normative):	Standard Test Conditions	29
D.1	Standard Equipment	29
D.1.1	Basic Equipment	29
D.1.2	Associated Equipment	29
D.2	Standard Environmental Test Conditions.....	29
D.3	Standard Conditions for the Primary Power Supply	29
D.3.1	General	29
D.3.2	Standard DC Test Voltage from Accumulator Batteries	29
D.3.3	Standard AC Voltage and Frequency	30
D.4	Standard Test Equipment	30
D.4.1	Access Network Simulator	30
D.4.2	AWGN Generator.....	30
D.4.3	CW Generator	30
D.4.4	Spectrum Analyzer	31
D.4.5	Average Power Meter.....	32
D.5	Functional System Setups	32
D.5.1	Functional Block Diagrams	32
D.6	Error Rates Measurement.....	34
D.6.1	Forward Traffic Channel PER.....	34
D.7	Confidence Interval	35
D.7.1	Confidence Level of Error Rate	35
D.7.2	Confidence level of Detection Time.....	37
Annex E (informative):	The EN title in the official languages	38
Annex F (informative):	Bibliography.....	39
History	40

Intellectual Property Rights

IPRs essential or potentially essential to the present document may have been declared to ETSI. The information pertaining to these essential IPRs, if any, is publicly available for **ETSI members and non-members**, and can be found in ETSI SR 000 314: "*Intellectual Property Rights (IPRs); Essential, or potentially Essential, IPRs notified to ETSI in respect of ETSI standards*", which is available from the ETSI Secretariat. Latest updates are available on the ETSI Web server (<http://webapp.etsi.org/IPR/home.asp>).

Pursuant to the ETSI IPR Policy, no investigation, including IPR searches, has been carried out by ETSI. No guarantee can be given as to the existence of other IPRs not referenced in ETSI SR 000 314 (or the updates on the ETSI Web server) which are, or may be, or may become, essential to the present document.

Foreword

This Harmonized European Standard (Telecommunications series) has been produced by ETSI Technical Committee Electromagnetic compatibility and Radio spectrum Matters (ERM), and is now submitted for the Public Enquiry phase of the ETSI standards Two-step Approval Procedure.

The present document has been produced by ETSI in response to a mandate from the European Commission issued under Council Directive 98/34/EC [i.1] (as amended) laying down a procedure for the provision of information in the field of technical standards and regulations.

The present document is intended to become a Harmonized Standard, the reference of which will be published in the Official Journal of the European Communities referencing the Directive 1999/5/EC [i.2] of the European Parliament and of the Council of 9 March 1999 on radio equipment and telecommunications terminal equipment and the mutual recognition of their conformity ("the R&TTE Directive").

Technical specifications relevant to Directive 1999/5/EC [i.2] are given in annex A.

The present document is part 16 of a multi-part deliverable covering the Base Stations (BS), Repeaters and User Equipment (UE) for IMT-2000 Third-Generation cellular networks, as identified below:

- Part 1: "Harmonized EN for IMT-2000, introduction and common requirements, covering the essential requirements of article 3.2 of the R&TTE Directive";
- Part 2: "Harmonized EN for IMT-2000, CDMA Direct Spread (UTRA FDD and E-UTRA FDD) (UE) covering the essential requirements of article 3.2 of the R&TTE Directive";
- Part 3: "Harmonized EN for IMT-2000, CDMA Direct Spread (UTRA FDD and E-UTRA FDD) (BS) covering the essential requirements of article 3.2 of the R&TTE Directive";
- Part 4: "Harmonized EN for IMT-2000, CDMA Multi-Carrier (cdma2000) and Evolved CDMA Multi-Carrier Ultra Mobile Broadband (UMB) (UE) covering the essential requirements of article 3.2 of the R&TTE Directive";
- Part 5: "Harmonized EN for IMT-2000, CDMA Multi-Carrier (cdma2000) and Evolved CDMA Multi-Carrier Ultra Mobile Broadband (UMB) (BS) covering the essential requirements of article 3.2 of the R&TTE Directive";
- Part 6: "Harmonized EN for IMT-2000, CDMA TDD (UTRA TDD and E-UTRA TDD) (UE) covering the essential requirements of article 3.2 of the R&TTE Directive";
- Part 7: "Harmonized EN for IMT-2000, CDMA TDD (UTRA TDD and E-UTRA TDD) (BS) covering the essential requirements of article 3.2 of the R&TTE Directive";
- Part 8: "Harmonized EN for IMT-2000, TDMA Single-Carrier (UWC 136) (UE) covering essential requirements of article 3.2 of the R&TTE Directive";
- Part 9: "Harmonized EN for IMT-2000, TDMA Single-Carrier (UWC 136) (BS) covering essential requirements of article 3.2 of the R&TTE Directive";

- Part 10: "Harmonized EN for IMT-2000, FDMA/TDMA (DECT) covering essential requirements of article 3.2 of the R&TTE Directive";
- Part 11: "Harmonized EN for IMT-2000, CDMA Direct Spread (UTRA FDD and E-UTRA FDD) (Repeaters) covering the essential requirements of article 3.2 of the R&TTE Directive";
- Part 12: "Harmonized EN for IMT-2000, CDMA Multi-Carrier (cdma2000) (Repeaters) covering the essential requirements of article 3.2 of the R&TTE Directive";
- Part 13: "Harmonized EN for IMT-2000, Evolved Universal Terrestrial Radio Access (E-UTRA) (UE) covering the essential requirements of article 3.2 of the R&TTE Directive";
- Part 14: "Harmonized EN for IMT-2000, Evolved Universal Terrestrial Radio Access (E-UTRA) (BS) covering the essential requirements of article 3.2 of the R&TTE Directive";
- Part 15: "Harmonized EN for IMT-2000, Evolved Universal Terrestrial Radio Access (E-UTRA) (FDD Repeaters) covering the essential requirements of article 3.2 of the R&TTE Directive";
- Part 16: "Harmonized EN for IMT-2000, Evolved CDMA Multi-Carrier Ultra Mobile Broadband (UMB) (UE) covering the essential requirements of article 3.2 of the R&TTE Directive";**
- Part 17: "Harmonized EN for IMT-2000, Evolved CDMA Multi-Carrier Ultra Mobile Broadband (UMB) (BS) covering the essential requirements of article 3.2 of the R&TTE Directive".

Proposed national transposition dates	
Date of latest announcement of this EN (doa):	3 months after ETSI publication
Date of latest publication of new National Standard or endorsement of this EN (dop/e):	6 months after doa
Date of withdrawal of any conflicting National Standard (dow):	18 months after doa

Introduction

The present document is part of a set of standards developed by ETSI and is designed to fit in a modular structure to cover all radio and telecommunications terminal equipment within the scope of the R&TTE Directive. The modular structure is shown in EG 201 399 [i.3].

1 Scope

The present document applies to the following radio equipment types:

- User Equipment (also denoted as Mobile Stations or Access Terminals) for Evolved CDMA Multi-Carrier Ultra Mobile Broadband (UMB) compliant with TIA-1121 [3].

These radio equipment types are capable of operating in all or any part of the frequency bands given in table 1-1.

Table 1-1: UMB mobile station operating bands

Band Class (BC)	Direction of transmission	UMB mobile station operating bands
6	Transmit	1 920 MHz to 1 980 MHz
	Receive	2 110 MHz to 2 170 MHz
8	Transmit	1 710 MHz to 1 785 MHz
	Receive	1 805 MHz to 1 880 MHz
9	Transmit	880 MHz to 915 MHz
	Receive	925 MHz to 960 MHz
13	Transmit	2 500 MHz to 2 570 MHz
	Receive	2 620 MHz to 2 690 MHz

The present document covers requirements for UMB User Equipment.

The present document is intended to cover the provisions of Directive 1999/5/EC [i.2] (R&TTE Directive), Article 3.2, which states that "... radio equipment shall be so constructed that it effectively uses the spectrum allocated to terrestrial/space radio communications and orbital resources so as to avoid harmful interference".

In addition to the present document, other ENs that specify technical requirements in respect of essential requirements under other parts of Article 3 of the R&TTE Directive [i.2] may apply to equipment within the scope of the present document.

NOTE: A list of such ENs is included on the web site <http://www.newapproach.org>.

2 References

References are either specific (identified by date of publication and/or edition number or version number) or non-specific.

- For a specific reference, subsequent revisions do not apply.
- Non-specific reference may be made only to a complete document or a part thereof and only in the following cases:
 - if it is accepted that it will be possible to use all future changes of the referenced document for the purposes of the referring document;
 - for informative references.

Referenced documents which are not found to be publicly available in the expected location might be found at <http://docbox.etsi.org/Reference>.

NOTE: While any hyperlinks included in this clause were valid at the time of publication ETSI cannot guarantee their long term validity.

2.1 Normative references

The following referenced documents are indispensable for the application of the present document. For dated references, only the edition cited applies. For non-specific references, the latest edition of the referenced document (including any amendments) applies.

- [1] ETSI EN 301 908-1 (V4.1.1): "Electromagnetic compatibility and Radio spectrum Matters (ERM); Base Stations (BS), Repeaters and User Equipment (UE) for IMT-2000 Third-Generation cellular networks; Part 1: Harmonized EN for IMT-2000, introduction and common requirements, covering the essential requirements of article 3.2 of the R&TTE Directive".
- [2] 3GPP2 C.S0089, Version 1.0, (March 2009): "Recommended Minimum Performance Standards for cdma2000 Ultra Mobile Broadband Access Terminal" (to be published as TIA-1171).

NOTE: Available at <ftp://ftp.3gpp2.org/TSGC/Working/2009/2009-03-NewOrleans/TSG-C-2009-03-New%20Orleans/Plenary/C00-20090330-116a%20C.S0089%20PPV.zip>.

- [3] TIA-1121 (2009): "Physical Layer for Ultra Mobile Broadband (UMB) Air Interface Specification" (see alternatively: 3GPP2 C. S0084-001-0 V3.0, August 2008).
- [4] 3GPP2 C.S0090, Version 1.0, (March 2009): "Test Application Specification for cdma2000 Ultra Mobile Broadband (UMB)" (to be published as TIA-1172).

NOTE: Available at http://www.3gpp2.org/Public_html/specs/C.S0090-0_v1.0_TAS_for_UMB-090402.pdf.

2.2 Informative references

The following referenced documents are not essential to the use of the present document but they assist the user with regard to a particular subject area. For non-specific references, the latest version of the referenced document (including any amendments) applies.

- [i.1] Directive 98/34/EC of the European Parliament and of the Council of 22 June 1998 laying down a procedure for the provision of information in the field of technical standards and regulations.
- [i.2] Directive 1999/5/EC of the European Parliament and of the Council of 9 March 1999 on radio equipment and telecommunications terminal equipment and the mutual recognition of their conformity (R&TTE Directive).
- [i.3] ETSI EG 201 399: "Electromagnetic compatibility and Radio spectrum Matters (ERM); A guide to the production of candidate Harmonized Standards for application under the R&TTE Directive".

3 Definitions, symbols and abbreviations

3.1 Definitions

For the purposes of the present document, the following terms and definitions apply:

access network: network equipment providing data connectivity between a packet switched data network (typically the Internet) and the access terminals

NOTE: Connectivity is typically provided at the Link Layer (PPP). An access network is equivalent to a base station in TIA-1121 [3]. In the context of transmitter testing, an access network applies to operation with a single carrier and single sector active only.

access terminal: device providing data connectivity to a user

NOTE: An access terminal may be connected to a computing device such as a laptop personal computer or may be self-contained data device such as a personal digital assistant.

ACK channel: used by the access terminal to inform the access network whether a data packet transmitted on the Forward Traffic Channel has been received successfully or not

active set: set of pilots assigned to a particular access terminal

adjacent channel leakage power ratio: ratio of the on-channel transmit power to the power measured in one of the adjacent channels with no active channel in the adjacent channel

band class: set of frequency channels and a numbering scheme for these channels

code division multiple access: technique for spread-spectrum multiple-access digital communications that creates channels through the use of unique code sequences

control channel: portion of the Forward Channel that carries control information

effective isotropic radiated power: product of the power supplied to the antenna and the antenna gain in a direction relative to an isotropic antenna

effective radiated power: product of the power supplied to the antenna and the antenna gain relative to a half-wave dipole in a given direction

error: when referring to packet error, an error event occurs when a packet FCS does not check

NOTE: When referring to a symbol error, an error event occurs when the symbol is classified as a valid symbol different from the transmitted symbol.

forward channel: UMB Channel from an access network to access terminals

NOTE: The Forward Channel is transmitted on a CDMA frequency assignment using a particular pilot PN offset.

forward test application protocol: test application protocol allowing Forward Link performance characterizations

NOTE: See 3GPP2 CS.0090 [4].

forward traffic channel: Forward Channel used to transport user and signaling traffic from an access network to an access terminal

Frame Check Sequence (FCS): Frame Check Sequence of the Physical Layer packets is a CRC

line impedance stabilization network: network inserted in the supply mains lead of apparatus to be tested that provides, in a given frequency range, a specified load impedance for the measurement of disturbance voltages and that may isolate the apparatus from the supply mains in that frequency range

packet: physical layer protocol data unit

power control bit: bit sent in every slot on the Reverse Power Control Channel that signals the access terminal to increase or decrease its transmit power

received signal quality indicator: Reverse Traffic Channel measure of signal quality related to the received Data E_b/N_t

NOTE: See also E_b and N_t .

reverse channel: UMB Channel from the access terminal to the access network

NOTE: From the access network's perspective, the Reverse Channel is the sum of all access terminal transmissions on a UMB frequency assignment.

reverse traffic channel: reverse channel used to transport user and signaling traffic from a single access terminal to one or more sectors

sector: part of the access network that provides the land side modem

serving sector: sector which is responsible for sending data to the access terminal

system time: time reference used by the system

NOTE: System Time is synchronous to UTC time (except for leap seconds) and uses the same time origin as Global Positioning System (GPS) time. All sectors use the same System Time (within a small error). Access terminals use the same System Time, offset by the propagation delay from the sector to the access terminal. See also Universal Coordinated Time.

traffic channel: communication path between an access terminal and an access network used for user and signaling traffic

NOTE: The term Traffic Channel implies a Forward Traffic Channel and Reverse Traffic Channel pair. See also Forward Traffic Channel and Reverse Traffic Channel.

Universal Coordinated Time (UTC): internationally agreed-upon time scale maintained by the Bureau International de l'Heure (BIH) used as the time reference by nearly all commonly available time and frequency distribution systems, e.g. WWV, WWVH, LORAN-C, Transit, Omega, and GPS

3.2 Symbols

For the purposes of the present document, the following symbols apply:

bps	Bits per second
C	Confidence level
dBc	The ratio (in dB) of the sideband power of a signal, measured in a given bandwidth at a given frequency offset from the center frequency of the same signal, to the total inband power of the signal
dBm	A measure of power expressed in terms of its ratio (in dB) to one milliwatt
dBm/Hz	A measure of power spectral density

NOTE: The ratio, dBm/Hz, is the power in one Hertz of bandwidth, where power is expressed in units of dBm.

dBW	A measure of power expressed in terms of its ratio (in dB) to one Watt
E_b	Average energy per information bit for the Reverse Data Channel at the sector RF input ports
E_b/N_t	The ratio in dB of the combined received energy per bit to the effective noise power spectral density for the Reverse Data Channel at the sector RF input ports
GHz	Gigahertz (10^9 Hertz)
I_0	The total received power spectral density, including signal and interference, as measured at the sector RF input ports
I_{oc}	The power spectral density of a band-limited white noise source (simulating interference from other users and cells) as measured at the sector RF input ports
I_{or}	The total transmit power spectral density of the Reverse Channel at the access terminal simulator antenna connector
\hat{I}_{or}	The received power spectral density of the Reverse Channel as measured at the sector RF input ports
kbps	Kilobits per second
kHz	Kilohertz (10^3 Hertz)
km/h	Kilometers per hour
MHz	Megahertz (10^6 Hertz)
ms	Millisecond (10^{-3} second)
ns	Nanosecond (10^{-9} second)
N_t	The effective noise power spectral density at the sector RF input ports
ppm	Parts per million
μ s	Microsecond (10^{-6} second)
χ^2	Chi-squared distribution

3.3 Abbreviations

For the purposes of the present document, the following abbreviations apply:

AC	Alternating Current
ACLR	Adjacent Channel Leakage power Ratio
ACLR1	Measured Adjacent Channel Leakage Ratio
ACLR2	Alternate Channel Leakage Ratio
ACS	Adjacent Channel Selectivity
AWGN	Additive White Gaussian Noise
Bps	Bits per second
CBW	Channel BandWidth
CDMA	Code Division Multiple Access
CRC	Cyclic Redundancy Code
CW	Continuous Waveform
DC	Direct Current
EIRP	Effective Isotropic Radiated Power
ERP	Effective Radiated Power
F-ACKCH	Forward Acknowledgement Channel
FCS	Frame Check Sequence
FER	Frame Error Rate
FLAB	Forward Link Assignment Block
F-PCCH	Forward Power control channel
F-PQICH	Forward Pilot Quality Indicator Channel
F-SPCH	Forward Start of Packet Channel
FTAP	Forward Test Application Protocol
LAB	Link Assignment Block
PCP	Packet Consolidation Protocol
PER	Packet Error Rate
PN	PseudoNoise
PPP	Point-to-Point Protocol
R-CDCCH	Reverse CDMA Dedicated Control Channel
RL	Reverse Link
RLAB	Reverse Link Assignment Block
SEM	Spectral Emissions Mask
TAP	Test Application Protocol
UE	User Equipment
UMB	Ultra Mobile Broadband
UTC	Universal Coordinated Time (Universel Temps Coordoné)
VSWR	Voltage Standing Wave Ratio

4 Technical requirements specifications

4.1 Environmental profile

The technical requirements of the present document apply under the environmental profile for operation of the equipment, which shall be declared by the supplier. The equipment shall comply with all the technical requirements of the present document at all times when operating within the boundary limits of the declared operational environmental profile.

For guidance on how a supplier can declare the environmental profile, see annex C.

4.2 Conformance requirements

The requirements in the present document are based on the assumption that the operating band (band class 6, 8, 9, 13) is shared between systems of the IMT-2000 family (for band class 8 and 9 also GSM) or systems having compatible characteristics.

4.2.1 Introduction

To meet the essential requirement under article 3.2 of Directive 1999/5/EC [i.2] (R&TTE Directive) for IMT-2000 User Equipment (UE) seven essential parameters in addition to those in EN 301 908-1 [1] have been identified. Table 4.2.1-1 provides a cross reference between these seven essential parameters and the seven corresponding technical requirements for equipment within the scope of the present document.

Table 4.2.1-1: Cross references

Essential parameter	Corresponding technical requirements
Spectrum emissions mask	4.2.2 Conducted spurious emissions when transmitting
Conducted spurious emissions in active mode	4.2.2 Conducted spurious emissions when transmitting
Accuracy of maximum output power	4.2.3 Transmitter maximum output power
Prevention of harmful interference through control of power	4.2.4 Minimum controlled output power
Conducted spurious emission in idle mode	4.2.5 Conducted spurious emissions when not transmitting (Receiver spurious emissions)
Impact of interference on receiver performance	4.2.6 Receiver Blocking characteristics
	4.2.7 Intermodulation spurious response attenuation
Receiver adjacent channel selectivity	4.2.8 Receiver Adjacent Channel Selectivity (ACS)
Control and Monitoring functions	EN 301 908-1 [1], clause 4.2.4 "Control and Monitoring Functions"

4.2.2 Conducted spurious emissions when transmitting

4.2.2.1 Definition

The conducted spurious emissions are emissions at frequencies that are outside the assigned UMB Channel, measured at the access terminal antenna connector. This test measures the spurious emissions during continuous transmission.

4.2.2.2 Limits

The spurious emissions with ten or more averages shall be less than the limits specified for general spectral emissions mask in table 4.2.2.2-1.

Table 4.2.2.2-1: General Spectral Emission Mask for different bandwidths

Offset from channel edge (MHz)	5 MHz Emissions in dBm/measurement BW	10 MHz Emissions in dBm/measurement BW	20 MHz Emissions in dBm/measurement BW	Measurement BW
±0 to 1	-15	-18	-21	30 kHz
±1 to 5	-10	-10	-10	1 MHz
±5 to 6	-13	-13	-13	1 MHz
±6 to 10	-25	-13	-13	1 MHz
±10 to 15		-25	-13	1 MHz
±15 to 20			-13	1 MHz
±20 to 25			-25	1 MHz

The spurious emissions with ten or more averages shall be less than the limits specified additional spectral emission masks (A-SEM1) in table 4.2.2.2-2.

Table 4.2.2.2-2: Additional Spectral Emission Mask (A-SEM1) for different bandwidths

Offset from channel edge (MHz)	5 MHz Emissions in dBm/measurement BW	10 MHz Emissions in dBm/measurement BW	20 MHz Emissions in dBm/measurement BW	Measurement BW
±0 to 1	-15	-18	-21	30 kHz
±1 to 5	-13	-13	-13	1 MHz
±5 to 6	-13	-13	-13	1 MHz
±6 to 10	-13	-13	-13	1 MHz
±10 to 15		-13	-13	1 MHz
±15 to 20			-13	1 MHz
±20 to 25			-13	1 MHz

The spurious emissions with ten or more averages shall be less than the limits specified for additional spectral emission masks (A-SEM2) in table 4.2.2.2-3.

Table 4.2.2.2-3: Additional Spectral Emission Mask (A-SEM2) for different bandwidths

Offset from channel edge (MHz)	5 MHz Emissions in dBm/measurement BW	10 MHz Emissions in dBm/measurement BW	20 MHz Emissions in dBm/measurement BW	Measurement BW
±0 to 1	-15	-18	-21	30 kHz
±1 to 5,5	-15	-13	-13	1 MHz
±5,5 to 10	-25	-25	-25	1 MHz
±10 to 15		-25	-25	1 MHz
±15 to 25			-25	1 MHz

In addition to the spectral emission mask requirements in table 4.2.2.2-1 through table 4.2.2.2-3, for frequency offsets greater than Δ_{SEM} from the channel edge specified in table 4.2.2.2-4, the spurious emissions with ten or more averages shall also be less than the requirements in table 4.2.2.2-5.

Table 4.2.2.2-4: Δ_{SEM} as a function of the channel BW

Channel Bandwidth (MHz)	5	10	20
Δ_{SEM} (MHz)	10	15	25

Table 4.2.2.2-5: Spurious emission requirements

Frequency Range	Maximum Level	Measurement BW
9 kHz ≤ f < 150 kHz	-36 dBm	1 kHz
150 kHz ≤ f < 30 MHz	-36 dBm	10 kHz
30 MHz ≤ f < 1 GHz	-36 dBm	100 kHz
1 GHz ≤ f < 12,75 GHz	-30 dBm	1 MHz

The measured adjacent channel leakage ratio (ACLR1) and alternate channel leakage ratio (ACLR2) shall be greater or equal to the values specified in table 4.2.2.2-6.

Table 4.2.2.2-6: ACLR specifications

Channel Bandwidth (MHz)	5 MHz	10 MHz	20 MHz
ACLR1 (dB)	30	30	30
ACLR2 (dB)	36	36	36
Signal and Adjacent Channel measurement BW (MHz)	4,61	9,22	18,44

4.2.2.3 Conformance

Conformance tests described in clause 5.3.1 shall be carried out.

4.2.3 Transmitter maximum output power

4.2.3.1 Definition

The maximum radiated RF output power is determined by the measurement of the maximum power that the access terminal transmits as measured at the access terminal antenna connector plus the antenna gain recommended by the access terminal manufacturer. The antenna gain is determined by using the Radiated Signal Measurement Procedures (see clause 2.6 in 3GPP2 CS.0089 [2]) and calculating the antenna gain for EIRP or ERP as appropriate.

4.2.3.2 Limits

For conforming to the general spectral emission mask, the maximum output power from the access terminal shall be $22,5 \text{ dBm} \pm 2 \text{ dB}$ (table 4.2.2.2-1). For conforming to the additional spectral emission mask-1, the maximum output power from the access terminal shall be $22 \text{ dBm} \pm 2 \text{ dB}$ (table 4.2.2.2-2). For conforming to the additional spectral emission mask-2, the maximum output power from the access terminal shall be $21,5 \text{ dBm} \pm 2 \text{ dB}$ (table 4.2.2.2-3). When the access terminal is using the special assignments, it will be allowed to increase the maximum output power by 2 dB for the following special assignments:

- 1) 1 tile at any point in the OFDM symbol;
- 2) 1 sub-band not at the edge of the channel.

4.2.3.3 Conformance

Conformance tests described in clause 5.3.2 shall be carried out.

4.2.4 Minimum controlled output power

4.2.4.1 Definition

The minimum controlled output power of the access terminal is defined as the broadband transmit power of the access terminal, i.e. the power in the channel bandwidth for all transmit bandwidth configurations, when the power is set to a minimum value.

4.2.4.2 Limits

The mean output power of the access terminal shall be less than -40 dBm for channel bandwidth.

4.2.4.3 Conformance

Conformance tests described in clause 5.3.3 shall be carried out.

4.2.5 Conducted spurious emissions when not transmitting

4.2.5.1 Definition

The conducted spurious emissions when not transmitting are spurious emissions generated or amplified in a receiver that appear at the access terminal antenna connector.

4.2.5.2 Limits

The mean conducted spurious emissions with ten or more averages for an access terminal shall be:

- a) Less than -76 dBm measured in a 1 MHz resolution bandwidth at the access terminal antenna connector, for frequencies within the access terminal receive band associated with each Band Class that the access terminal supports.
- b) Less than -61 dBm, measured in a 1 MHz resolution bandwidth at the access terminal antenna connector, for frequencies within the access terminal transmit band associated with each Band Class that the access terminal supports.
- c) Less than -57 dBm measured in a 100 kHz resolution bandwidth at the access terminal antenna connector, for frequencies from 30 MHz to 1 GHz.
- d) Less than -47 dBm measured in a 1 MHz resolution bandwidth at the access terminal antenna connector, for all frequencies in the range from 1 GHz to 12,75 GHz.

4.2.5.3 Conformance

Conformance tests described in clause 5.3.4 shall be carried out.

4.2.6 Receiver Blocking characteristics

4.2.6.1 Definition

The blocking characteristic is a measure of the receiver's ability to receive a wanted signal at its assigned channel frequency in the presence of an unwanted interferer on frequencies other than those of the spurious response (or the adjacent channel covered by Adjacent Channel Selectivity test), without this unwanted input signal causing a degradation of the performance of the receiver beyond a specified limit. The blocking performance shall apply at all frequencies except those at which spurious response occurs.

The specifications are divided into in-band, out-of-band, and narrow band blocking.

In-band blocking: The in-band blocking specifications pertain only to the cases where the blockers are located at a carrier frequency offset up to ± 15 MHz from the signal carrier frequency; the blockers are UMB signals with a channel bandwidth of 5 MHz.

Out-of-band blocking: The out-of-band blocking specifications pertain to those cases where the blockers are located at a carrier frequency offset greater than 15 MHz from the signal carrier frequency; the blockers are CW. The out-of-band blocking is divided into 3 basic frequency ranges:

- Frequency Range 1: $15 \text{ MHz} < \text{Blocker carrier frequency offset from the signal} \leq 60 \text{ MHz}$.
- Frequency Range 2: $60 \text{ MHz} < \text{Blocker carrier frequency offset from the signal} \leq 85 \text{ MHz}$.
- Frequency Range 3: $\text{Blocker carrier frequency offset from the signal} > 85 \text{ MHz}$.

In addition a 4th range is defined that is the transmit channel of some Band Classes.

Narrowband blocking: The narrow band blocking specifications pertain to a case of a CW blocker close to the signal channel edge.

4.2.6.2 Limits

In-band blocking: The FER in cases 1 and 2 defined in table 4.2.6.2-1 shall not exceed 1 % with 95 % confidence (see clause D.7).

Out-of-band blocking: The FER in cases 1 through 4 defined in table 4.2.6.2-2 shall not exceed 1 % with 95 % confidence (see clause D.7). For Frequency Ranges 1, 2 and 3, up to 24 exceptions are allowed for spurious response frequencies in each assigned frequency channel when measured using a 1 MHz step size. For these exceptions the requirements in table 4.2.6.2-3 apply. For Frequency Range 4, up to 8 exceptions are allowed for spurious response frequencies in each assigned frequency channel when measured using a 1 MHz step size. For these exceptions the requirements in table 4.2.6.2-3 apply.

Narrowband blocking: The FER shall not exceed 1 % with 95 % confidence (see clause D.7).

Table 4.2.6.2-1: Test Parameters for Receiver Blocking Characteristics (In-Band)

Channel Bandwidth	Transmission configuration	Signal level Unit	Signal Level	Case 1 (see note)		Case 2 (see note)	
				Blocker Level dBm/4,61 MHz	Blocker Offset (MHz)	Blocker Level dBm/4,61 MHz	Blocker Offset (MHz)
5 MHz	A1 in table B.1-1	dBm/4,61 MHz	<REFSENS> + 3 dB	-56	±10	-44	≤ -15 and ≥ 15
10 MHz	A2 in table B.1-1	dBm/9,22 MHz	<REFSENS> + 3 dB	-56	±12,5	-44	≤ -17,5 and ≥ 17,5
20 MHz	A3 in table B.1-1	dBm/28,44 MHz	<REFSENS> + 3 dB	-56	±17,5	-44	≤ -22,5 and ≥ 22,5

NOTE 1: The Blocker is a 5 MHz UMB modulated signal occupying the maximum transmission bandwidth (5 MHz minus guard band).

NOTE 2: Frequency offset is measured from the carrier frequency of the UMB signal under test to the carrier frequency of the blocker.

NOTE 3: The requirements shall be met while the access terminal is transmitting a UMB signal occupying the maximum transmission bandwidth (i.e. the CBW minus guard band) of the desired signal at a mean power of 20 dBm.

NOTE 4: The specifications shall apply even if the blockers fall outside the Band Class of operation.

Table 4.2.6.2-2: Test Parameters for Receiver Blocking Characteristics (Out-Of-Band)

Parameter	Unit	Case 1 (Frequency Range 1)	Case 2 (Frequency Range 2)	Case 3 (Frequency Range 3)	Case 4 (Frequency Range 4)
Signal Level	dBm/4,61 MHz (A1 in table B.1-1)	<REFSENS>+ 3 dB	<REFSENS>+ 3 dB	<REFSENS>+ 3 dB	<REFSENS> + 3 dB
	dBm/9,22 MHz (A2 in table B.1-1)				
	dBm/18,44 MHz (A3 in table B.1-1)				
Blocker Level (CW)	dBm	-44	-30	-15	-15
Blocker Offset for all Band Classes	MHz	$f_{FL} - 15$ to $f_{FL} - 60$ and $f_{FL} + 15$ to $f_{FL} + 60$	$f_{FL} - 60$ to $f_{FL} - 85$ and $f_{FL} + 60$ to $f_{FL} + 85$	$f_{FL} - 85$ to 1MHz and $f_{FL} + 85$ to 12750	-

NOTE: The requirement needs to be met while the AT is transmitting a UMB signal occupying the maximum transmission BW (i.e. the CBW minus guard band) of the desired signal at a mean power of 20 dBm. f_{FL} is the carrier frequency of the desired receive signal.

Table 4.2.6.2-3: Spurious response specifications

Channel Bandwidth	Signal level Unit	Signal Level	Blocker Level (see note) (dBm)
5 MHz	dBm/4,61 MHz	<REFSENS> + 3 dB	-44
10 MHz	dBm/9,22 MHz	<REFSENS> + 3 dB	-44
20 MHz	dBm/18,44 MHz	<REFSENS> + 3 dB	-44

NOTE: The Blocker is CW and is located at spurious response frequencies. The requirement needs to be met while the Access Terminal is transmitting a UMB signal occupying the maximum transmission BW (i.e. the CBW minus guard band) of the desired signal at a mean power of 20 dBm.

Table 4.2.6.2-4: Narrow band blocking specifications

CBW (MHz)	Transmission Configuration	Signal Level	Blocker Offset from carrier (MHz)	Blocker Level (dBm)
5 MHz	A1 in table B.1-1	<REFSENS> + 10 dB dBm/4,61 MHz	2,7	-57
10 MHz	A2 in table B.1-1	<REFSENS> + 10 dB dBm/9,22 MHz	5,2	-57
20 MHz	A3 in table B.1-1	<REFSENS> + 10 dB dBm/18,44 MHz	10,2	-57

NOTE: The requirement needs to be met while the Access Terminal is transmitting a UMB signal occupying the maximum transmission BW (i.e. the CBW minus guard band) of the desired signal at a mean power of 20 dBm.

4.2.6.3 Conformance

Conformance tests described in clause 5.3.5 shall be carried out.

4.2.7 Intermodulation spurious response attenuation

4.2.7.1 Definition

The intermodulation spurious response attenuation is a measure of a receiver's ability to receive a UMB signal on its assigned channel frequency in the presence of two interfering CW tones (narrowband test) and an interfering 5 MHz UMB signal along with an interfering CW tone (broadband test). These tones are separated from the assigned channel frequency and are separated from each other such that the third order mixing of the two interfering CW tones can occur in the non-linear elements of the receiver, producing an interfering signal in the band of the desired signal. The receiver performance is measured by the Frame Error Rate (FER).

4.2.7.2 Limits

The FER in all the tests shall not exceed 1 % with 95 % confidence (see clause D.7).

Table 4.2.7.2-1: Test Parameters for Intermodulation Spurious Response Attenuation for Broadband Interference

Transmission configuration	Signal Level	1 st Blocker (CW)		2 nd Blocker (see note 1)	
		Level (dBm)	Frequency Offset (MHz)	Level (dBm)	Frequency Offset (MHz)
A1 in table B.1-1	<REFSENS> + 3 dB dBm/4,61 MHz	-46	±10	-46	±20
A2 in table B.1-1	<REFSENS> + 3 dB dBm/9,22 MHz	-46	±12,5	-46	±25
A3 in table B.1-1	<REFSENS> + 3 dB dBm/18,44 MHz	-46	±17,5	-46	±35
NOTE 1: The second blocker is a 5 MHz UMB signal occupying the maximum transmission BW (i.e. 5 MHz minus guard band).					
NOTE 2: Frequency offset is measured from the carrier frequency of the UMB signal under test to the carrier frequency of the blocker.					
NOTE 3: The requirements shall be met while the access terminal is transmitting a UMB signal occupying the maximum transmission bandwidth (i.e. the channel bandwidth minus guard band) of the desired signal at a mean power of 20 dBm.					

Table 4.2.7.2-2: Test Parameters for Intermodulation Spurious Response Attenuation for Narrowband Interference

Transmission configuration	Signal Level	1 st Blocker (CW)		2 nd Blocker (CW)	
		Level (dBm)	Frequency Offset (MHz)	Level (dBm)	Frequency Offset (MHz)
A1 in table B.1-1	<REFSENS> + 10 dB dBm/4,61 MHz	-44	±3,5	-44	±5,9
A2 in table B.1-1	<REFSENS> + 10 dB dBm/9,22 MHz	-44	±6	-44	±8,4
A3 in table B.1-1	<REFSENS> + 10 dB dBm/18,44 MHz	-44	±11	-44	±13,4
NOTE 1: The requirements shall be met while the access terminal is transmitting a UMB signal occupying the maximum transmission bandwidth (i.e. the channel bandwidth minus guard band) of the desired signal at a mean power of 20 dBm.					
NOTE 2: Frequency offset is measured from the carrier frequency of the UMB signal under test to the carrier frequency of the blocker.					

4.2.7.3 Conformance

Conformance tests described in clause 5.3.6 shall be carried out.

4.2.8 Receiver Adjacent Channel Selectivity (ACS)

4.2.8.1 Definition

The adjacent channel selectivity is a measure of the ability to receive a UMB signal on the assigned frequency in the presence of a 5 MHz UMB signal at a given frequency offset from the centre frequency of the assigned channel.

4.2.8.2 Limits

The FER in Tests 1 and 2 shall not exceed 1 % with 95 % confidence. For any signal level between the levels defined in Test 1 and 2, the FER shall not exceed 1 % FER with 95 % confidence (see clause D.7).

Table 4.2.8.2-1: Test Parameters for Adjacent Channel Selectivity

Transmission configuration	Frequency Offset, MHz	Signal level Unit	Test 1		Test 2	
			Signal Level	Interferer Level (dBm/4,61 MHz)	Signal Level	Interferer Level (dBm/4,61 MHz)
A1 in table B.1-1	±5	dBm/4,61 MHz	<REFSENS> + 14 dB	-52 + x + y	-55	-25
A2 in table B.1-1	±10	dBm/9,22 MHz	<REFSENS> + 14 dB	-52 + x + y	-52	-25
A3 in table B.1-1	±20	dBm/18,44 MHz	<REFSENS> + 14 dB	-52 + x + y	-49	-25

NOTE 1: x is the SNR required to decode the respective transmission configuration and y is the implementation loss. x = -1 dB and y = 2 dB.
NOTE 2: Frequency offset is measured from the carrier frequency of the UMB signal under test to the carrier frequency of the blocker.
NOTE 3: The requirements shall be met while the access terminal is transmitting a UMB signal occupying the maximum transmission bandwidth (i.e. the channel bandwidth minus guard band) of the desired signal at a mean power of 20 dBm.

4.2.8.3 Conformance

Conformance tests described in clause 5.3.7 shall be carried out.

5 Testing for compliance with technical requirements

5.1 Environmental conditions for testing

Tests defined in the present document shall be carried out at representative points within the boundary limits of the declared operational environmental profile.

Where technical performance varies subject to environmental conditions, tests shall be carried out under a sufficient variety of environmental conditions (within the boundary limits of the declared operational environmental profile) to give confidence of compliance for the affected technical requirements.

Normally it should be sufficient for all tests to be conducted using normal test conditions except where otherwise stated. For guidance on the use of other test conditions to be used in order to show compliance reference can be made to 3GPP2 CS.0089 [2].

The measurement system required for each test is described in annex D and in 3GPP2 CS.0089 [2].

5.2 Interpretation of the measurement results

The interpretation of the results recorded in a test report for the measurements described in the present document shall be as follows:

- the measured value related to the corresponding limit shall be used to decide whether an equipment meets the requirements of the present document;
- the value of the measurement uncertainty or the accuracy of each piece of test equipment used for the measurement of each parameter shall be included in the test report; only test equipment meeting the performance requirements for standard test equipment as defined in clause D.4 (3GPP2 CS.0089 [2], clause 6.4);
- the test set-up of each test shall be equivalent to the test set-up descriptions in clause D.5 (3GPP2 CS.0089 [2], clause 6.5);
- the recorded value of the measurement uncertainty or the recorded value of the accuracy of each piece of test equipment shall be equal to or better than the figures in clause D.7 (3GPP2 CS.0089 [2], clause 6.7).

5.3 Essential radio test suites

5.3.1 Conducted spurious emissions when transmitting

This test specifies the emission requirements channel bandwidth of 5 MHz, 10 MHz and 20 MHz. Specifications of the emission requirements include a general Spectral Emissions Mask (SEM) and two additional spectral emission masks (A-SEM1 and A-SEM2, respectively). The additional requirements are to be signaled to the access terminal via some broadcast control channel. The concept of additional requirement being signaled to access terminal is helpful since the the deployment of various technologies and the channelization on each band is not readily available.

The test shall be carried out for every Band Class and channel bandwidth supported by the access terminal. This test shall be carried out for any packet format index corresponding to modulation order of 64-QAM.

- 1) Connect the sector to the access terminal antenna connector as shown in figure D.5.1-4. The AWGN generator and the CW generator are not applicable in this test. Connect a spectrum analyzer (or other suitable test equipment) to the access terminal antenna connector.
- 2) Ensure that MAC and Physical layer configuration is as specified in clause B.2.1.
- 3) Ensure that the access terminal and access network can use the session and TAP configuration as per clause B.2.3.2.
- 4) Set up a connection between the access terminal and the access network and ensure that the configuration specified in step 3) is in use.
- 5) Ensure that the LAB assignments and channels are transmitted are as per clause B.2.2.2.
- 6) Instruct the access network to transmit "up" power control commands continuously to the access terminal.
- 7) Measure the spurious emission levels.
- 8) For adjacent channel power leakage ratio measurement, measure the in-band power and also the power in the first and second adjacent channels for the specified channel bandwidths. Compute the difference between the in-band power and the power in the adjacent channels to measure the adjacent channel power leakage ratio.

The results obtained shall be compared to the limits in clause 4.2.2.2 to prove compliance.

5.3.2 Transmitter maximum output power

The test shall be carried out for every Band Class and channel bandwidth supported by the access terminal. This test shall be carried out for any packet format index corresponding to modulation order of 64-QAM.

- 1) Connect the sector to the access terminal antenna connector as shown in figure D.5.1-4. The AWGN generator and the CW generator are not applicable in this test. Connect a spectrum analyzer (or other suitable test equipment) to the access terminal antenna connector.
- 2) Ensure that MAC and Physical layer configuration is as specified in clause B.2.1.
- 3) Ensure that the access terminal and access network can use the session and TAP configuration as per clause B.2.3.2.
- 4) Set up a connection between the access terminal and the access network and ensure that the configuration specified in step 3) is in use.
- 5) Ensure that the LAB assignments and channels are transmitted are as per clause B.2.2.
- 6) Instruct the access network to transmit "up" power control commands continuously to the access terminal.
- 7) Measure the mean access terminal output power at the access terminal antenna connector.

The results obtained shall be compared to the limits in clause 4.2.3.2 to prove compliance.

5.3.3 Minimum controlled output power

The test shall be carried out for every Band Class and channel bandwidth supported by the terminal.

- 1) Connect the sector to the access terminal antenna connector as shown in figure D.5.1-4. The AWGN generator and the CW generator are not applicable in this test. Connect a spectrum analyzer (or other suitable test equipment) to the access terminal antenna connector.
- 2) Ensure that MAC and Physical layer configuration is as specified in clause B.2.1.
- 3) Ensure that the access terminal and access network can use the session and TAP configuration as per clause B.2.3.1.
- 4) Set up a connection between the access terminal and the access network and ensure that the configuration specified in step 3) is in use.
- 5) Ensure that the LAB assignments and channels are transmitted as per clause B.2.2.1.
- 6) Instruct the access network to transmit "down" power control commands continuously to the access terminal.

The results obtained shall be compared to the limits in clause 4.2.4.2 to prove compliance.

5.3.4 Conducted spurious emissions when not transmitting

The test shall be carried out for every Band Class and channel bandwidth supported by the terminal.

- 1) Connect a spectrum analyzer (or other suitable test equipment) to the access terminal antenna connector.
- 2) For each Band Class that the access terminal supports, configure the access terminal to operate in that band and perform step 3).
- 3) Sweep the spectrum analyzer over a frequency range from 30 MHz to at least 12,75 GHz and measure the spurious emissions levels.

The results obtained shall be compared to the limits in clause 4.2.5.2 to prove compliance.

5.3.5 Receiver Blocking characteristics

The test shall be carried out for every Band Class and channel bandwidth supported by the terminal.

- 1) Connect the sector to the access terminal antenna connector as shown in figure D.5.1-4.
- 2) Ensure that MAC and Physical layer configuration is as specified in clause B.2.1 and meets the requirements specified in the column of table B.1-1 corresponding to channel bandwidth used for the specified test.
- 3) Ensure that the access terminal and access network can use the session and TAP configuration as per clause B.2.3.1.
- 4) Set up a connection between the access terminal and the access network and ensure that the configuration specified in step 2) is in use.
- 5) Ensure that the LAB assignments and channels are transmitted as per clause B.2.2.1 and meeting the requirements specified in the column of table B.1-1 corresponding to channel bandwidth used for the test.
- 6) Instruct the access network to transmit power control commands such that the mean transmit power from the access terminal is 20 dBm.
- 7) For In-band blocking test, adjust the desired signal and blocker signal level to the level specified in table 4.2.6.2-1 for case 1 for the channel bandwidth used for the test. For out-of-band blocking test, adjust the desired signal and blocker signal level to the level specified in table 4.2.6.2-2 for case 1 for the channel bandwidth used for the test. For narrowband blocking test, adjust the desired signal and blocker signal level to the level specified in table 4.2.6.2-4 for the channel bandwidth used for the test.
- 8) Instruct the TAP flow at the access network to start transmitting full buffer data to the access terminal.

- 9) Measure the FER for the test using the Loop Back packets transmitted by the access terminal.
- 10) For In-band blocking test, adjust the desired signal and blocker signal level specified in table 4.2.6.2-1 for case 2 for the channel bandwidth used for the test.
- 11) Repeat steps 8) and 9).
- 12) For out-of-band blocking test, adjust the desired signal and blocker signal level to the level specified in table 4.2.6.2-2 for cases 2 through 4 for the channel bandwidth used for the test.
- 13) Repeat steps 8) and 9).

The results obtained shall be compared to the limits in clause 4.2.6.2 to prove compliance.

5.3.6 Intermodulation spurious response attenuation

This test specifies the intermodulation spurious response attenuation requirements for channel bandwidth greater than or equal to 5 MHz.

The test shall be carried out for every Band Class and channel bandwidth supported by the terminal.

- 1) Connect the sector to the access terminal antenna connector as shown in figure D.5.1-4.
- 2) Ensure that MAC and Physical layer configuration is as specified in clause B.2.1 and meets the requirements specified in the column of table B.1-1 corresponding to channel bandwidth used for the specified test.
- 3) Ensure that the access terminal and access network can use the session and TAP configuration as per clause B.2.3.1.
- 4) Set up a connection between the access terminal and the access network and ensure that the configuration specified in step 3) is in use.
- 5) Ensure that the LAB assignments and channels are transmitted as per clause B.2.2.1 and meeting the requirements specified in the column of table B.1-1 corresponding to channel bandwidth used for the test.
- 6) Instruct the access network to transmit power control commands such that the mean transmit power from the access terminal is 20 dBm.
- 7) Adjust the received power level of the desired signal and the interferers to the level specified in table 4.2.7.2-1 (for broadband blocker) or table 4.2.7.2-2 (for narrowband blocker) for the channel bandwidth used for the test.
- 8) Instruct the TAP flow at the access network to start transmitting full buffer data to the access terminal.
- 9) Measure the FER for the test using the Loop Back packets transmitted by the access terminal.

The results obtained shall be compared to the limits in clause 4.2.7.2 to prove compliance.

5.3.7 Receiver Adjacent Channel Selectivity (ACS)

The test shall be carried out for every Band Class and channel bandwidth supported by the terminal.

- 1) Connect the sector to the access terminal antenna connector as shown in figure D.5.1-5.
- 2) Ensure that MAC and Physical layer configuration is as specified in clause B.2.1 and meets the requirements specified in the column of table B.1-1 corresponding to channel bandwidth used for the specified test.
- 3) Ensure that the access terminal and access network can use the session and TAP configuration as per clause B.2.3.1.
- 4) Set up a connection between the access terminal and the access network and ensure that the configuration specified in step 3) is in use.
- 5) Ensure that the LAB assignments and channels are transmitted as per clause B.2.2.1 and meeting the requirements specified in the column of table B.1-1 corresponding to channel bandwidth used for the test.

- 6) Instruct the access network to transmit power control commands such that the mean transmit power from the access terminal is 20 dBm.
- 7) Adjust the received signal power and interference power to the level specified in table 4.2.8.2-1 for Test 1 for the channel bandwidth used for the test.
- 8) Instruct the TAP flow at the access network to start transmitting full buffer data to the access terminal.
- 9) Measure the FER for the test using the Loop Back packets transmitted by the access terminal.
- 10) Adjust the received signal power and interference power to the level specified in table 4.2.8.2-1: for Test 2 for the channel bandwidth used for the test.
- 11) Repeat steps 8) and 9).

The results obtained shall be compared to the limits in clause 4.2.8.2 to prove compliance.

Annex A (normative): HS Requirements and conformance Test specifications Table (HS-RTT)

The HS Requirements and conformance Test specifications Table (HS-RTT) in table A-1 serves a number of purposes, as follows:

- it provides a statement of all the requirements in words and by cross reference to (a) specific clause(s) in the present document or to (a) specific clause(s) in (a) specific referenced document(s);
- it provides a statement of all the test procedures corresponding to those requirements by cross reference to (a) specific clause(s) in the present document or to (a) specific clause(s) in (a) specific referenced document(s);
- it qualifies each requirement to be either:
 - Unconditional: meaning that the requirement applies in all circumstances; or
 - Conditional: meaning that the requirement is dependant on the manufacturer having chosen to support optional functionality defined within the schedule.
- in the case of Conditional requirements, it associates the requirement with the particular optional service or functionality;
- it qualifies each test procedure to be either:
 - Essential: meaning that it is included with the Essential Radio Test Suite and therefore the requirement shall be demonstrated to be met in accordance with the referenced procedures;
 - Other: meaning that the test procedure is illustrative but other means of demonstrating compliance with the requirement are permitted.

Table A-1: HS Requirements and conformance Test specifications Table (HS-RTT)

Harmonized Standard EN 301 908-16						
The following requirements and test specifications are relevant to the presumption of conformity under the article 3.2 of the R&TTE Directive						
Requirement			Requirement Conditionality		Test Specification	
No	Description	Reference: Clause No	U/C	Condition	E/O	Reference: Clause No
1	Conducted spurious emissions when transmitting	4.2.2	U		E	5.3.1
2	Transmitter maximum output power	4.2.3	U		E	5.3.2
3	Minimum controlled output power	4.2.4	U		E	5.3.3
4	Conducted spurious emissions when not transmitting	4.2.5	U		E	5.3.4
5	Receiver Blocking characteristics	4.2.6	U		E	5.3.5
6	Intermodulation spurious response attenuation	4.2.7	U		E	5.3.6
7	Receiver Adjacent Channel Selectivity	4.2.8	U		E	5.3.7

Key to columns:**Requirement:**

No A unique identifier for one row of the table which may be used to identify a requirement or its test specification.

Description A textual reference to the requirement.

Clause Number Identification of clause(s) defining the requirement in the present document unless another document is referenced explicitly.

Requirement Conditionality:

U/C Indicates whether the requirement is to be *unconditionally* applicable (U) or is *conditional* upon the manufacturers claimed functionality of the equipment (C).

Condition Explains the conditions when the requirement shall or shall not be applicable for a technical requirement which is classified "conditional".

Test Specification:

E/O Indicates whether the test specification forms part of the Essential Radio Test Suite (E) or whether it is one of the Other Test Suite (O).

NOTE: All tests whether "E" or "O" are relevant to the requirements. Rows designated "E" collectively make up the Essential Radio Test Suite; those designated "O" make up the Other Test Suite; for those designated "X" there is no test specified corresponding to the requirement. The completion of all tests classified "E" as specified with satisfactory outcomes is a necessary condition for a presumption of conformity. Compliance with requirements associated with tests classified "O" or "X" is a necessary condition for presumption of conformity, although conformance with the requirement may be claimed by an equivalent test or by manufacturer's assertion supported by appropriate entries in the technical construction file.

Clause Number Identification of clause(s) defining the test specification in the present document unless another document is referenced explicitly. Where no test is specified (that is, where the previous field is "X") this field remains blank.

Annex B (normative): Mobile Station configurations

B.1 Transmission configurations

Table B.1-1 specifies mobile station test configurations A1 to A6 employed in various test procedures (Receiver Blocking Characteristics, Intermodulation Spurious Response Attenuation, Adjacent Channel Selectivity).

Table B.1-1: Test Configurations for Receiver Sensitivity, High Throughput and Dynamic Range

Transmission configuration for Reference channel	Sensitivity Test			High Throughput and Dynamic Range Test		
	A1	A2	A3	A4	A5	A6
Allocated Tiles	30	60	120	30	60	120
Guard Band (tiles per side)	1	2	4	1	2	4
Symbols per Tile	8	8	8	8	8	8
Modulation	QPSK	QPSK	QPSK	64QAM	64QAM	64QAM
Packet format	1	1	1	6	6	6
Number of HARQ transmissions	1	1	1	1	1	1
Payload size (bits)	2 544	5 120	10 264	11 496	23 016	40 640
Tones per Tile	16	16	16	16	16	16
Data channel CRC (bits)	24	24	24	24	24	24
Cyclic Prefix (usec)	13,02	13,02	13,02	13,02	13,02	13,02
Symbol duration (μs)	120,44	120,44	120,44	120,44	120,44	120,44
Frame duration (μs)	963,52	963,52	963,52	963,52	963,52	963,52
PHY layer throughput (kbps)	2669	5338	10676	11956	23912	41514
Channel bandwidth (MHz)	5	10	20	5	10	20
Transmission bandwidth (MHz)	4,61	9,22	18,44	4,61	9,22	18,44

B.2 Common Procedures

B.2.1 MAC and Physical Layer Configuration

This clause provides various MAC and Physical layer configuration for the tests specified in the present document. Some attributes or parameter values for individual tests may differ from the value specified in this clause. In this case values specified in the individual tests are applicable.

B.2.2 Forward and Reverse Channels and Link Assignment Block (LAB) Assignments

B.2.2.1 Forward Link PER Measurement Test

LAB assignment to the access terminal should force the forward and reverse link transmissions on the same interlace. This interlace shall be different from the interlaces used for RL CDMA Control Segment (R-CDCCH) and the Power Control channel (F-PCCH). Other forward link control channels should not be transmitted (F-ACK, F-PQICH, F-SPCH).

Data assignment should be such that the R-ACKCH transmission is on an interlace different from that for the control channel.

B.2.2.2 Emissions Test

Reverse Link Assignment Block (RLAB) assignment to the access terminal should force the reverse link transmissions on all interlaces. The Reverse Link Assignment Block (RLAB) assignment should also include mother node. The Forward Link Assignment Block (FLAB) assignment should ensure that there is no transmission on the forward link.

B.2.3 Session and Test Application Configurations

B.2.3.1 Forward Link PER Measurement

The access network and access terminal shall use the following for this test:

- 1) An active TAP flow at the access terminal that will transmit Loop Back packets for the data packets of the flow that were transmitted on the forward link. Note, this can be achieved by using a TAP Packet Type of 0x00 for this flow.
- 2) A TAP flow at the access terminal that generates data for transmission on the reverse link. The TAP flow should generate data at a rate such that the physical layer at the access terminal should always have data available for transmission on the RTC. Note, this can be achieved by using a TAP Packet Type of 0x01 for this flow. The stream to which this flow is mapped should have lower priority than the stream used for transmission of Loop Back packets. Loop Back shall be disabled for this flow.
- 3) The FL and RL should transmit a packet only once, irrespective of the ack for the transmission received through the h-arq. The receiver should expect to receive a new packet in the next transmission on this interlace. Note, this can be achieved by negotiating the TAP attributes NumHARQFL and NumHARQRL to a value of 1.
- 4) Access network shall transmit only 1 RoutePacket per Consolidated packet.
- 5) Access network shall use pseudorandom padding for the Packet Consolidation Protocol (PCP) packets and shall negotiate TAP attribute PsuedoRandomPaddingEnabledFL to 0x01.
- 6) Other attributes required by the TAP loop back mode.

B.2.3.2 Emissions Test

The access network and access terminal shall use the following for this test:

- 1) An active TAP flow at the access terminal that will transmit full buffer data packets on the reverse link. Loop back should be disabled for this flow. Note, this can be achieved by using a TAP Packet Type of 0x01 for this flow. All other FL and RL TAP flows should be disabled.

The RL should transmit a packet only once, irrespective of the ack for the transmission received through the h-arq. The receiver should expect to receive a new packet in the next transmission on this interlace. Note, this can be achieved by negotiating the TAP attribute NumHARQRL to a value of 1.

Annex C (normative): Environmental profile

C.1 Introduction

The following clause contains a copy of the description of environmental requirements as specified in 3GPP2 CS.0089 [2], clauses 5 and 6. This should provide some guidance on how the environmental profile can be declared for the purpose of the present document.

C.2 Temperature and Power Supply Voltage

The temperature and voltage ranges denote the ranges of ambient temperature and power supply input voltages over which the access terminal will operate and meet the requirements of these standards. The ambient temperature is the average temperature of the air surrounding the access terminal. The power supply voltage is the voltage applied at the input terminals of the access terminal. The manufacturer shall specify the temperature range and the power supply voltage over which the equipment is to operate. In order to provide a convenient means for the manufacturer to express the temperature range under which the access terminal conforms to these recommended minimum standards, temperature ranges designated by letters are defined in table C.2-1.

Table C.2-1: Temperature Ranges

Designator	Range
A	-40 °C to +70 °C
B	-30 °C to +60 °C
C	-20 °C to +50 °C
D	0 °C to +45 °C

C.3 High Humidity

The term "high humidity" denotes the relative humidity at which the access terminal will operate with the specified performance.

C.4 Vibration Stability

The vibration stability is the ability of the access terminal to maintain specified mechanical and electrical performance after being vibrated.

C.5 Shock Stability

The shock stability is the ability of the access terminal to maintain specified mechanical and electrical performance after being shocked.

Annex D (normative): Standard Test Conditions

D.1 Standard Equipment

D.1.1 Basic Equipment

The equipment shall be assembled, and any necessary adjustments shall be made in accordance with the manufacturer's instructions for the mode of operation required. When alternative modes are available, the equipment shall be assembled and adjusted in accordance with the relevant instructions. A complete series of measurements shall be made for each mode of operation.

D.1.2 Associated Equipment

The access terminal equipment may include associated equipment during tests, provided that the associated equipment is normally used in the operation of the equipment under test. For access terminal equipment, this may include power supplies, handsets, cradles, charging stands, control cables, and battery cables.

D.2 Standard Environmental Test Conditions

Measurements under standard atmospheric conditions shall be carried out under any combination of the following conditions:

Temperature:	+15 °C to +35 °C.
Relative humidity:	45 % to 75 %.
Air pressure:	86 000 Pa to 106 000 Pa (860 mbar to 1 060 mbar).

If desired, the results of the measurements can be corrected by calculation to the standard reference temperature of 25 °C and the standard reference air pressure of 101 300 Pa (1013 mbar).

D.3 Standard Conditions for the Primary Power Supply

D.3.1 General

The standard test voltages shall be those specified by the manufacturer, or an equivalent type that duplicates the voltage, impedance, and ampere hours (if relevant for the measurement) of the recommended supply.

D.3.2 Standard DC Test Voltage from Accumulator Batteries

The standard (or nominal) DC test voltage specified by the manufacturer shall be equal to the standard test voltage of the type of accumulator to be used, multiplied by the number of cells minus an average DC power cable loss value that the manufacturer determines as being typical (or applicable) for a given installation. Since accumulator batteries may or may not be under charge or may be in a state of discharge when the equipment is being operated, the manufacturer shall also test the equipment at anticipated voltage extremes above and below the standard voltage. The test voltages shall not deviate from the stated values by more than ± 2 % during a series of measurements carried out as part of a single test on the same equipment.

D.3.3 Standard AC Voltage and Frequency

For equipment that operates from the AC mains, the standard AC test voltage shall be equal to the nominal voltage specified by the manufacturer. If the equipment is provided with different input taps, the one designated "nominal" shall be used. The standard test frequency and the test voltage shall not deviate from their nominal values by more than ± 2 %.

The equipment shall operate without degradation with input voltage variations of up to ± 10 %, and shall maintain its specified transmitter frequency stability for input voltage variations of up to ± 15 %. The frequency range over which the equipment is to operate shall be specified by the manufacturer.

D.4 Standard Test Equipment

D.4.1 Access Network Simulator

The access terminal simulator shall be compliant with TIA-1121 [3] and 3GPP2 CS.0090 [4].

D.4.2 AWGN Generator

The AWGN generator shall meet the following minimum performance requirements:

- Minimum bandwidth: 1,8 MHz.
- Frequency ranges:
 - For each Band Class under test, the AWGN generator must tune over the range of transmit and receive frequencies for that Band Class.

NOTE: The frequency ranges are based on covering the receive band and frequencies as great as 5 MHz outside the band.

- Frequency resolution: 1 kHz.
- Output accuracy: ± 2 dB for outputs greater than or equal to -80 dBm/1,23 MHz.
- Amplitude resolution: 0,1 dB.
- Output range: -20 dBm to -95 dBm/1,23 MHz.
- The AWGN generator shall be uncorrelated to the ideal transmitter signal.

D.4.3 CW Generator

The CW generator shall meet the following minimum performance requirements:

- Output frequency range: Tunable over applicable range of radio frequencies.
- Frequency accuracy: ± 1 ppm.
- Frequency resolution: 100 Hz.
- Output range: -50 dBm to -10 dBm, and off.
- Output accuracy: $\pm 1,0$ dB for above output range and frequencies.
- Amplitude resolution: 0,1 dB.
- Output phase noise: As required.

- Output Phase Noise at -20 dBm Power:
 - -144 dBc/Hz at a frequency of 1 GHz as measured at a 285 kHz offset (Band Class 9).
 - -144 dBc/Hz at a frequency of 2 GHz as measured at a 635 kHz offset (Band Classes 6, 8 and 13).

D.4.4 Spectrum Analyzer

The spectrum analyzer shall provide the following functionality:

- General purpose frequency domain measurements.
- Integrated channel power measurements (power spectral density in the specified channel bandwidth).
- The spectrum analyzer shall meet the following minimum performance requirements.
- Frequency range: Tunable over the applicable radio frequency range.
- Frequency resolution: 1 kHz.
- Frequency accuracy: $\pm 0,2$ ppm.
- Displayed dynamic range: 70 dB.
- Display log scale fidelity: ± 1 dB over the above displayed dynamic range.
- Amplitude measurement range for signals from 10 MHz to either 2,6 GHz for Band Class 9, or 6 GHz for Band Classes 6, 8 and 13:
 - 1) Power measured in 30 kHz resolution bandwidth: -90 dBm to +20 dBm.
 - 2) Integrated channel power in the specified channel bandwidth: -70 dBm to +40 dBm.
 - 3) Noise floor: -140 dBm/Hz.
 - 4) External attenuation may be used to meet the high power end of the range and may be considered as part of the equipment.
- Absolute amplitude accuracy (for integrated channel power measurements):
 - 1) ± 1 dB over the range of -40 dBm to +20 dBm.
 - 2) $\pm 1,3$ dB over the range of -70 dBm to +20 dBm.
- Relative flatness: $\pm 1,5$ dB over frequency range 10 MHz to either 2,6 GHz for Band Class 9, or 6 GHz for Band Classes 6, 8 and 13.
- Resolution bandwidth filter: Synchronously tuned or Gaussian (at least 3 poles) with 3 dB bandwidth selections of 1 MHz, 300 kHz, 100 kHz, and 30 kHz.
- Post detection video filters: Selectable in decade steps from 100 Hz to at least 1 MHz.
- Detection modes: Average detection mode.
- RF input impedance: Nominal 50 Ω .

The spectrum analyzer may also provide the functionality of time domain (zero span) measurements with true average power determination. If this functionality is provided, the spectrum analyzer shall meet the following additional minimum performance requirements:

- Time domain sweep time: Selectable from 50 μ s to 100 ms.
- Delayed sweep trigger: Selectable from 5 μ s to 40 ms.
- External sweep trigger.

- Sufficient bandwidths to make the time domain measurements.

D.4.5 Average Power Meter

The power meter shall provide the following functionality:

- Average power measurements.
- True RMS detection for both sinusoidal and non-sinusoidal signals.
- Absolute power in linear (watt) and logarithmic (dBm) units.
- Relative (offset) power in dB and percentage units.
- Automatic calibration and zeroing.
- Averaging of multiple readings.

The power meter shall meet the following minimum performance requirements:

- Frequency range: 10 MHz to either 1 GHz for Band Class 9, or 2 GHz for Band Classes 6, 8 and 13.
- Power range: -70 dBm (100 pW) to +40 dBm (10 W).
- Different sensors may be required to optimally provide this power range. External attenuation may be used to meet the high power end of the range and may be considered as part of the equipment.
- Absolute and relative power accuracy: $\pm 0,2$ dB (5 %).
- Excludes sensor and source mismatch (VSWR) errors, zeroing errors (significant at bottom end of sensor range), and power linearity errors (significant at top end of sensor range).
- Power measurement resolution: Selectable between 0,1 dB or 0,01 dB.
- Sensor VSWR: 1,15:1.

D.5 Functional System Setups

D.5.1 Functional Block Diagrams

Figure D.5.1-1 through figure D.5.1-5 show the functional block diagrams of the set-up for different tests:

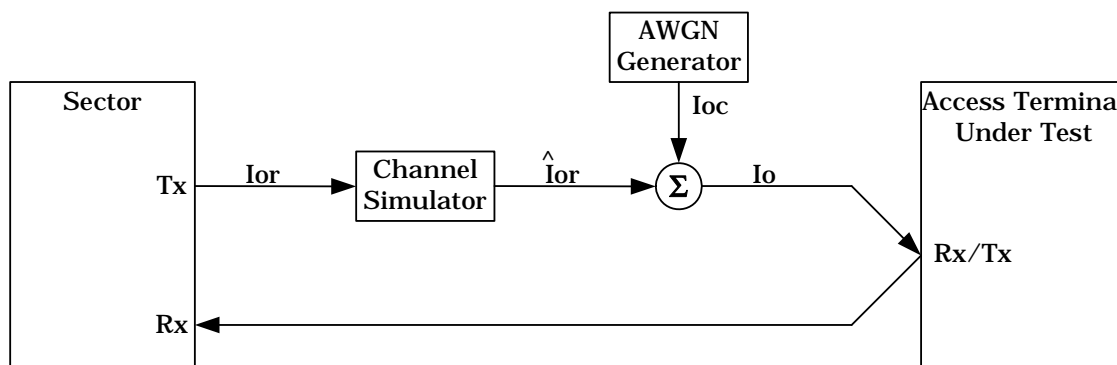

Figure D.5.1-1: Functional Set-up for Traffic Channel Tests in Fading Channel with Full Packet Activity

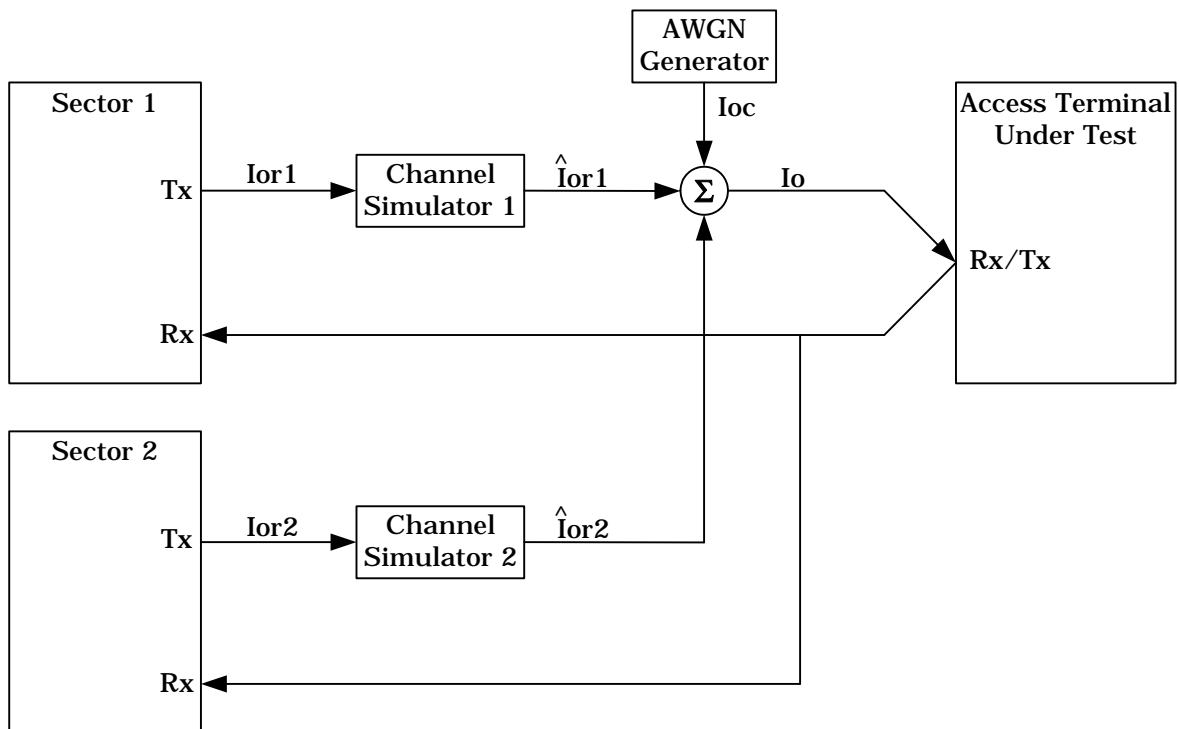

Figure D.5.1-2: Functional Set-up for Tests in Soft Handoff

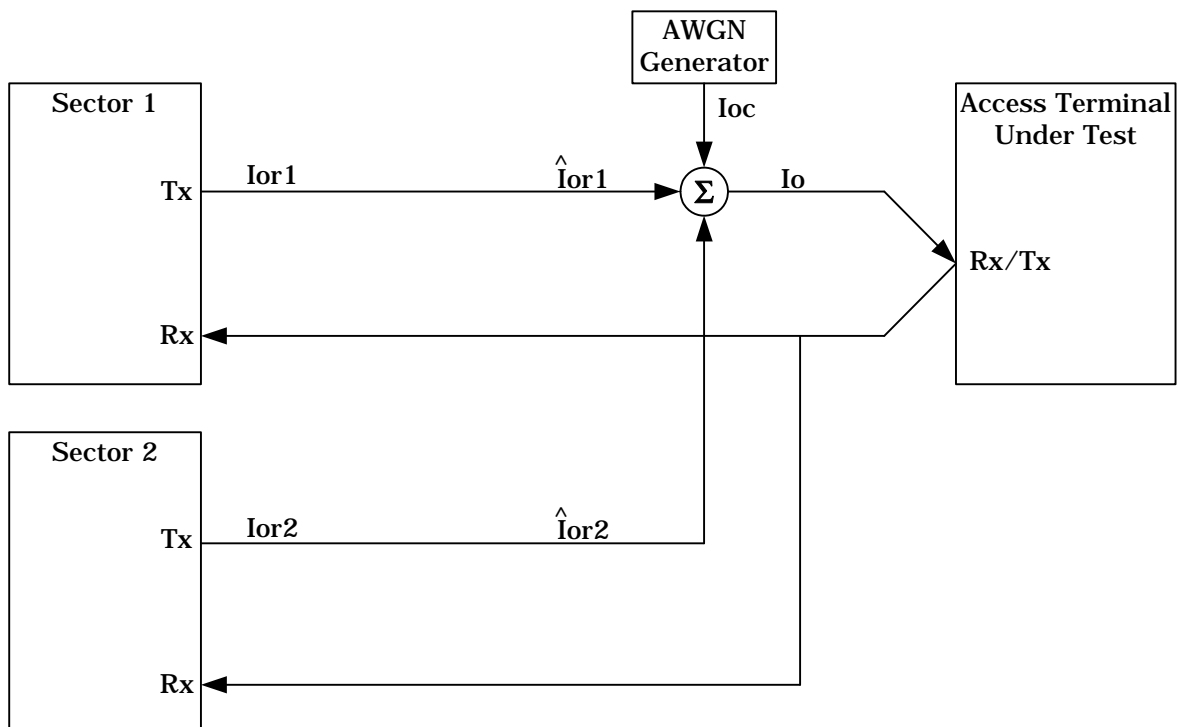

Figure D.5.1-3: Functional Set-up for Searcher Tests in Handoff

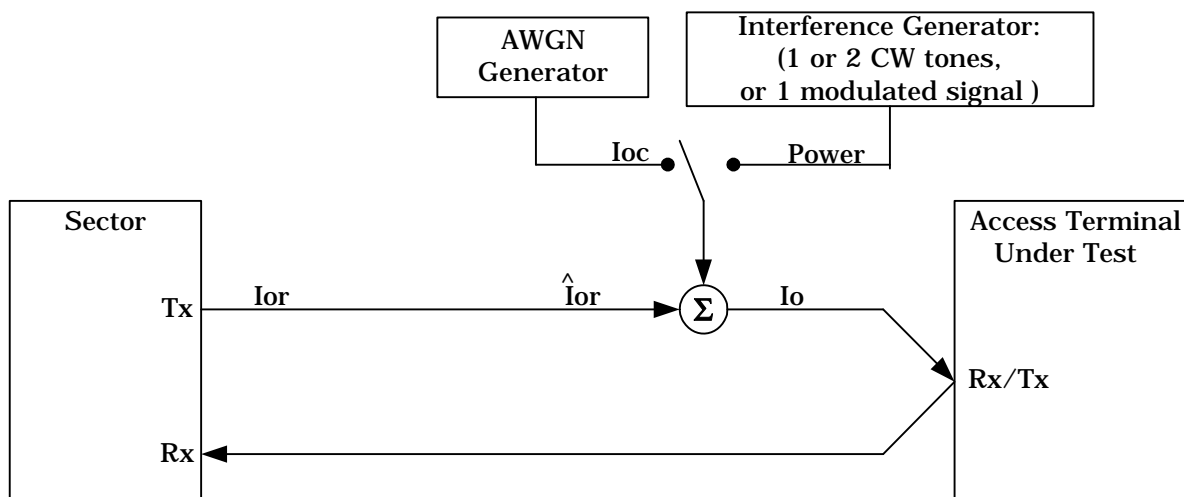

Figure D.5.1-4: Functional Set-up for Tests without Fading

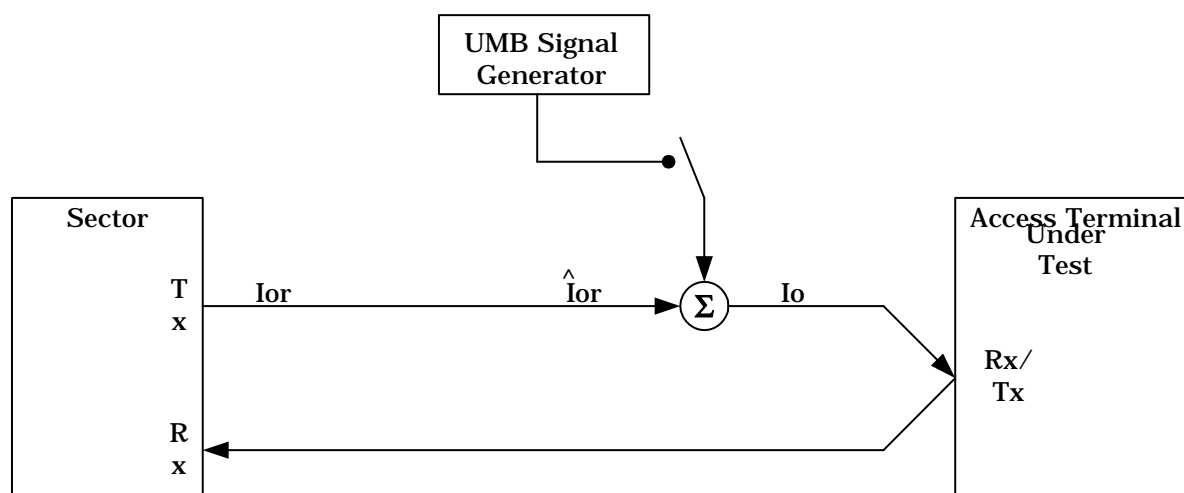

Figure D.5.1-5: Functional Set-up for Test for Adjacent Channel Selectivity

D.6 Error Rates Measurement

D.6.1 Forward Traffic Channel PER

The Forward Traffic Channel FER for data rate "i" is calculated as follows:

$$FER_i = \frac{(\text{Number of Bad frames at Rate } i)}{(\text{Number of Transmitted frames at Rate } i)}$$

where (# Bad frames at Rate i) and (# Transmitted frames at Rate i) are parameters obtained from the Test Application FTAP, as defined in 3GPP2 CS.0090 [4].

The average Forward Traffic Channel FER is calculated as follows:

$$FER = \frac{\sum_i (\text{Number of bad frames at Rate } i)}{\sum_i (\text{Number of transmitted frames at Rate } i)}$$

where the summations are done over all the Forward Traffic Channel data rates.

D.7 Confidence Interval

D.7.1 Confidence Level of Error Rate

When it is required that an error rate (e.g. FER) of a given test be less than a specified value with confidence level C , the procedure for a one-sided confidence limit is applied. This procedure assumes that all errors occur independently, resulting in a Poisson distribution of errors during the test. Since test procedures do not specify either the test duration or the number of errors that are allowed, the error rate at the specified confidence level is computed after the test is completed. Alternatively, if sufficiently few errors occur during the test, the test may be halted when the desired confidence level on the error rate is achieved.

In order to have a confidence level C that the true error rate is less than the specified error rate, the measured error rate shall be less than:

$$p' = 2pk/\chi^2(1-C, 2k),$$

where p' is the measured error rate, p is the specified error rate, and k is the number of errors that occur during the test. In this expression, $\chi^2(\alpha, n)$ is the value x such that $P(X > x) = \alpha$, where X is a chi-squared distributed random variable with n degrees of freedom. Values for $\chi^2(\alpha, n)$ can be found in various tables. Equivalently stated, satisfying this expression means that the true error rate has probability C of being less than the specified error rate.

Figures D.7.1-1 and D.7.1-2 provide curves of the demonstrated performance as a fraction of the targeted specification versus the number of errors measured in the tests for confidence levels of 95 % and 90 %, respectively. The test duration can be determined by dividing the number of errors by the demonstrated error rate. From the figure, as the number of errors becomes large, the measured error rate becomes very close to the specified error rate. This means that if the true error rate is close to the specified error rate, the test time can become increasingly long.

Figure D.7.1-3 provides a curve of maximum FER as a function of the number of packets tested for the specified packet error rate of 0,01 with 95 % confidence level. Figure D.7.1-4 provides a curve of maximum FER as a function of the number of packets tested for the specified packet error rate of 0,1 with 90 % confidence level.

If no errors occur during a test, the test may be terminated when the test time is sufficient to assure the confidence level on error rate is achieved. This is done by assuming one error could have occurred at the end of the test, and applying the criteria stated above with $k = 1$.

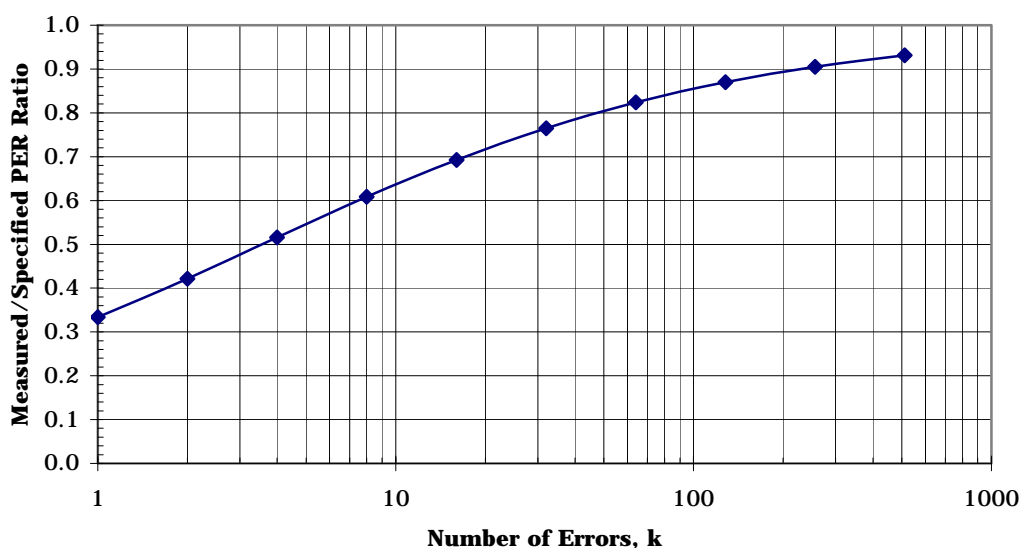

Figure D.7.1-1: Rate Ratio Bound as a Function of Number of Errors (k) for 95% Confidence

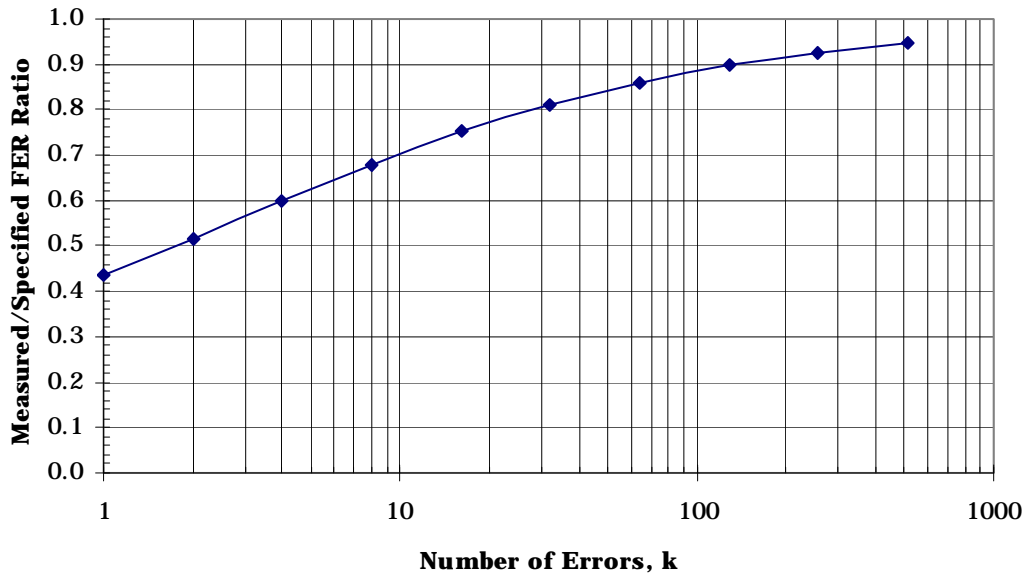

Figure D.7.1-2: Rate Ratio Bound as a Function of Number of Errors (k) for 90% Confidence

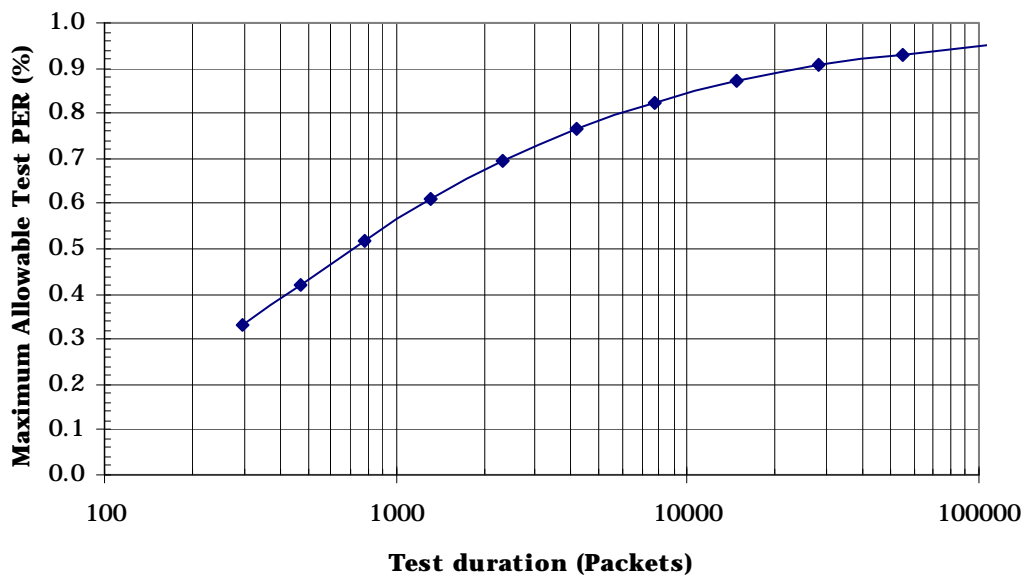

Figure D.7.1-3: Test Requirement for 95% Confidence of FER = 0,01

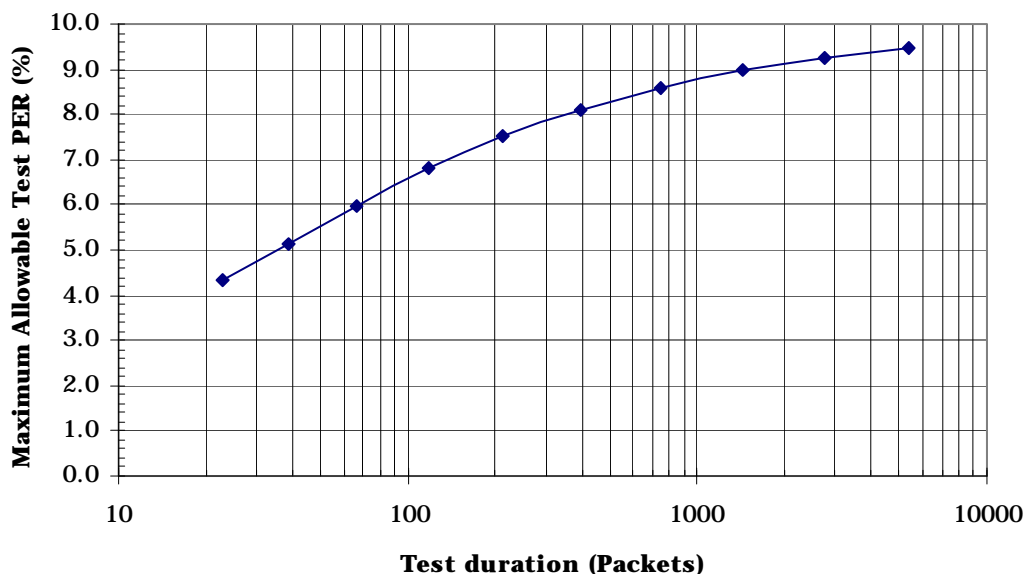

Figure D.7.1-4: Test Requirement for 90% Confidence of FER = 0,1

D.7.2 Confidence level of Detection Time

Several tests involve the successful detection of a strong pilot, or the successful loss detection of a weak pilot. Tests of this type require that the time to have a successful outcome be less than a specified value, T , with probability, p , and confidence level, C . One method to establish a confidence level from the measurements is to declare an error if the time to success exceeds the specified time, T . Assume that k errors occur during N repeated tests. The method used in clause D.7.1 can be used to determine the confidence level of the test by replacing p' with k/N . The resulting requirement on k , in order to have a confidence level C that the true error rate is less than the specified error rate, is that k satisfy the relationship:

$$\chi^2(1-C, 2k) = 2Np$$

Annex E (informative): The EN title in the official languages

The enlargement of the European Union (EU) resulted in a requirement from the EU for a larger number of languages for the translation of the titles of Harmonized Standards and mandated ENs that are to be listed in the Official Journal to support the implementation of this legislation.

For this reason the title translation concerning the present document can be consulted via the [e-approval](#) application.

Annex F (informative): Bibliography

- Directive 2004/108/EC of the European Parliament and of the Council of 15 December 2004 on the approximation of the laws of the Member States relating to electromagnetic compatibility and repealing Directive 89/336/EEC (text with EEA relevance (EMC Directive)).
- Council Directive 89/336/EEC of 3 May 1989 on the approximation of the laws of the Member States relating to electromagnetic compatibility (EMC Directive).
- Council Directive 73/23/EEC of 19 February 1973 on the harmonization of the laws of Member States relating to electrical equipment designed for use within certain voltage limits (LV Directive).
- ITU-R Recommendation SM.329-10 (2003): "Unwanted emissions in the spurious domain".
- TIA-1170 (2009): "Recommended Minimum Performance Standards for cdma2000 Ultra Mobile Broadband Access Network" (see alternatively: 3GPP2 C.S0088-0 V1.0, January 2009).

History

Document history			
V4.1.1	April 2009	Public Enquiry	PE 20090828:2009-04-30 to 2009-08-28