



**IMT cellular networks;
Harmonised Standard for access to radio spectrum;
Part 14: Evolved Universal Terrestrial Radio Access (E-UTRA)
Base Stations (BS)**

Reference

REN/MSG-TFES-13-14

Keywords

3G, 3GPP, cellular, digital, E-UTRA, IMT, IMT-2000, LTE, mobile, radio, regulation, UMTS

ETSI

650 Route des Lucioles
F-06921 Sophia Antipolis Cedex - FRANCE

Tel.: +33 4 92 94 42 00 Fax: +33 4 93 65 47 16

Siret N° 348 623 562 00017 - NAF 742 C
Association à but non lucratif enregistrée à la
Sous-Préfecture de Grasse (06) N° 7803/88

Important notice

The present document can be downloaded from:

<http://www.etsi.org/standards-search>

The present document may be made available in electronic versions and/or in print. The content of any electronic and/or print versions of the present document shall not be modified without the prior written authorization of ETSI. In case of any existing or perceived difference in contents between such versions and/or in print, the prevailing version of an ETSI deliverable is the one made publicly available in PDF format at www.etsi.org/deliver.

Users of the present document should be aware that the document may be subject to revision or change of status.

Information on the current status of this and other ETSI documents is available at

<https://portal.etsi.org/TB/ETSIDeliverableStatus.aspx>

If you find errors in the present document, please send your comment to one of the following services:

<https://portal.etsi.org/People/CommiteeSupportStaff.aspx>

Copyright Notification

No part may be reproduced or utilized in any form or by any means, electronic or mechanical, including photocopying and microfilm except as authorized by written permission of ETSI.

The content of the PDF version shall not be modified without the written authorization of ETSI.

The copyright and the foregoing restriction extend to reproduction in all media.

© ETSI 2019.

All rights reserved.

DECT™, **PLUGTESTS™**, **UMTS™** and the ETSI logo are trademarks of ETSI registered for the benefit of its Members.

3GPP™ and **LTE™** are trademarks of ETSI registered for the benefit of its Members and of the 3GPP Organizational Partners.

oneM2M™ logo is a trademark of ETSI registered for the benefit of its Members and of the oneM2M Partners.

GSM® and the GSM logo are trademarks registered and owned by the GSM Association.

Contents

Intellectual Property Rights	7
Foreword.....	7
Modal verbs terminology.....	7
Introduction	8
1 Scope	9
2 References	10
2.1 Normative references	10
2.2 Informative references.....	11
3 Definition of terms, symbols and abbreviations.....	12
3.1 Terms.....	12
3.2 Symbols.....	18
3.3 Abbreviations	20
4 Technical requirements specifications	21
4.1 Environmental profile.....	21
4.2 Conformance requirements	21
4.2.1 Introduction.....	21
4.2.2 Operating band unwanted emissions	28
4.2.2.1 Definition	28
4.2.2.2 Limits	28
4.2.2.2.0 General	28
4.2.2.2.1 Limits for Wide Area BS (bands 1, 3, 8, 32, 33, 34 or 65).....	30
4.2.2.2.2 Limits for Wide Area BS (bands 7, 22, 38, 40, 42, 43 and 69)	31
4.2.2.2.3 Limits for Wide Area BS (bands 20, 28, 31, 67 and 68)	34
4.2.2.2.4 Limits for Local Area BS	35
4.2.2.2.5 Limits for Home BS	37
4.2.2.2.6 Additional limits for protection of DTT	39
4.2.2.2.7 Limits for protection of adjacent band services.....	39
4.2.2.2.8 Limits for Medium Range BS	39
4.2.2.2.9 Additional limits for operation in band 32	44
4.2.2.2.10 Minimum requirements for Local Area and Medium Range BS in band 46	44
4.2.2.2.11 Minimum requirements for stand-alone NB-IoT Wide Area BS.....	45
4.2.2.3 Conformance.....	45
4.2.3 Adjacent Channel Leakage Power Ratio (ACLR)	45
4.2.3.1 Definition	45
4.2.3.2 Void.....	46
4.2.3.3 Void.....	46
4.2.3.4 Limits	46
4.2.3.4.1 ACLR Limits	46
4.2.3.4.2 Cumulative ACLR test requirement in non-contiguous spectrum limits.....	48
4.2.3.5 Conformance.....	50
4.2.4 Transmitter spurious emissions.....	50
4.2.4.1 Definition	50
4.2.4.2 Limits	51
4.2.4.2.1 Spurious emissions	51
4.2.4.2.2 Co-existence with other systems	51
4.2.4.2.3 Protection of the BS receiver of own or different BS	53
4.2.4.2.4 Co-existence with Home BS operating in other bands	53
4.2.4.3 Conformance.....	54
4.2.5 Base Station maximum output power	55
4.2.5.1 Definition	55
4.2.5.2 Limit.....	55
4.2.5.3 Conformance.....	55
4.2.6 Transmitter intermodulation	55
4.2.6.1 Definition	55

4.2.6.2	Limit.....	56
4.2.6.3	Conformance.....	56
4.2.7	Receiver spurious emissions.....	57
4.2.7.1	Definition.....	57
4.2.7.2	Limit.....	57
4.2.7.3	Conformance.....	57
4.2.8	Blocking characteristics.....	58
4.2.8.1	Definition.....	58
4.2.8.2	Limit.....	58
4.2.8.3	Conformance.....	63
4.2.9	Receiver intermodulation characteristics.....	64
4.2.9.1	Definition.....	64
4.2.9.2	Limit.....	64
4.2.9.3	Conformance.....	70
4.2.10	Adjacent Channel Selectivity (ACS) and narrow-band blocking.....	71
4.2.10.1	Definition.....	71
4.2.10.2	Limit.....	71
4.2.10.3	Conformance.....	77
4.2.11	Home BS output power for adjacent UTRA channel protection.....	77
4.2.11.1	Definition.....	77
4.2.11.2	Limit.....	77
4.2.11.3	Conformance.....	78
4.2.12	Home BS output power for adjacent E-UTRA channel protection.....	78
4.2.12.1	Definition and applicability.....	78
4.2.12.2	Limit.....	78
4.2.12.3	Conformance.....	79
4.2.13	Home BS output power for co-channel E-UTRA protection.....	79
4.2.13.1	Definition and applicability.....	79
4.2.13.2	Limit.....	79
4.2.13.3	Conformance.....	80
4.2.14	Reference sensitivity level.....	80
4.2.14.1	Definition.....	80
4.2.14.2	Limits.....	80
4.2.14.3	Conformance.....	82
4.2.15	Downlink channel access procedure (Listen before talk - LBT).....	82
4.2.15.1	General.....	82
4.2.15.2	Limits.....	83
4.2.15.3	Conformance.....	83
4.2.16	Dynamic Frequency Selection (DFS).....	83
4.2.16.1	General.....	83
4.2.16.2	Limits.....	83
4.2.16.3	Conformance.....	83
4.2.17	Base Station output power (band 46).....	83
4.2.17.1	General.....	83
4.2.17.2	Limits.....	83
4.2.17.3	Conformance.....	83
5	Testing for compliance with technical requirements.....	84
5.1	Environmental conditions for testing.....	84
5.2	Interpretation of the measurement results.....	84
5.3	Essential radio test suites.....	84
5.3.0	Introduction.....	84
5.3.1	Operating band unwanted emissions.....	85
5.3.1.0	General.....	85
5.3.1.1	Initial conditions.....	85
5.3.1.2	Procedure.....	85
5.3.1.3	Test requirement.....	86
5.3.2	Adjacent Channel Leakage power Ratio (ACLR).....	86
5.3.2.1	Initial conditions.....	86
5.3.2.2	Procedure.....	87
5.3.2.3	Test requirement.....	87
5.3.3	Transmitter spurious emissions.....	88

5.3.3.0	General	88
5.3.3.1	Initial conditions	88
5.3.3.2	Procedure	88
5.3.3.3	Test requirements	89
5.3.4	Base Station maximum output power	89
5.3.4.0	General	89
5.3.4.1	Initial conditions	89
5.3.4.2	Procedure	90
5.3.4.3	Test requirement	90
5.3.5	Transmitter intermodulation	90
5.3.5.0	General	90
5.3.5.1	Initial conditions	90
5.3.5.2	Procedures	91
5.3.5.3	Test requirement	92
5.3.6	Receiver spurious emissions	92
5.3.6.0	General	92
5.3.6.1	Initial conditions	92
5.3.6.2	Procedure	93
5.3.6.3	Test requirement	93
5.3.7	Blocking characteristics	93
5.3.7.0	General	93
5.3.7.1	Initial conditions	93
5.3.7.2	Procedure	94
5.3.7.3	Test requirement	96
5.3.8	Receiver intermodulation characteristics	96
5.3.8.0	General	96
5.3.8.1	Initial conditions	96
5.3.8.2	Procedures	96
5.3.8.3	Test requirement	98
5.3.9	Adjacent Channel Selectivity (ACS) and narrow-band blocking	98
5.3.9.0	General	98
5.3.9.1	Initial conditions	98
5.3.9.2	Procedure for Adjacent Channel Selectivity	98
5.3.9.3	Procedure for narrow-band blocking	99
5.3.9.4	Test requirement	101
5.3.10	Home BS output power for adjacent UTRA channel protection	101
5.3.10.1	Initial conditions	101
5.3.10.2	Procedure	101
5.3.10.3	Test requirement	102
5.3.11	Home BS output power for adjacent E-UTRA channel protection	102
5.3.11.1	Initial conditions	102
5.3.11.2	Procedure	102
5.3.11.3	Test requirement	103
5.3.12	Home BS output power for co-channel E-UTRA protection	103
5.3.12.1	Initial conditions	103
5.3.12.2	Procedure	103
5.3.12.3	Test requirement	104
5.3.13	Reference sensitivity level	104
5.3.13.0	General	104
5.3.13.1	Initial conditions	104
5.3.13.2	Procedure	104
5.3.13.3	Test requirement	105
5.3.14	Downlink channel access procedure	105
5.3.14.1	General	105
5.3.14.2	Initial conditions	105
5.3.14.3	Procedure	105
5.3.14.4	Test requirements	106
5.3.15	Dynamic frequency selection (DFS)	106
5.3.16	Base Station output power (band 46)	106

Annex A (informative):	Relationship between the present document and the essential requirements of Directive 2014/53/EU	107
-------------------------------	---	------------

Annex B (normative):	Base Station configurations.....	109
B.1	Reception with multiple receiver antenna connectors, receiver diversity	109
B.2	Duplexers	109
B.3	Power supply options	109
B.4	Ancillary RF amplifiers.....	110
B.5	BS using antenna arrays	110
B.5.0	General	110
B.5.1	Receiver tests.....	111
B.5.2	Transmitter tests	111
B.6	Transmission with multiple transmitter antenna connectors	112
B.7	BS with integrated Iuant BS modem.....	112
Annex C (informative):	Recommended maximum measurement uncertainty	113
Annex D (informative):	Bibliography.....	115
Annex E (informative):	Change history	116
History		117

Intellectual Property Rights

Essential patents

IPRs essential or potentially essential to normative deliverables may have been declared to ETSI. The information pertaining to these essential IPRs, if any, is publicly available for **ETSI members and non-members**, and can be found in ETSI SR 000 314: "*Intellectual Property Rights (IPRs); Essential, or potentially Essential, IPRs notified to ETSI in respect of ETSI standards*", which is available from the ETSI Secretariat. Latest updates are available on the ETSI Web server (<https://ipr.etsi.org/>).

Pursuant to the ETSI IPR Policy, no investigation, including IPR searches, has been carried out by ETSI. No guarantee can be given as to the existence of other IPRs not referenced in ETSI SR 000 314 (or the updates on the ETSI Web server) which are, or may be, or may become, essential to the present document.

Trademarks

The present document may include trademarks and/or tradenames which are asserted and/or registered by their owners. ETSI claims no ownership of these except for any which are indicated as being the property of ETSI, and conveys no right to use or reproduce any trademark and/or tradename. Mention of those trademarks in the present document does not constitute an endorsement by ETSI of products, services or organizations associated with those trademarks.

Foreword

This final draft Harmonised European Standard (EN) has been produced by ETSI Technical Committee Mobile Standards Group (MSG), and is now submitted for the Vote phase of the ETSI standards EN Approval Procedure.

For non-EU countries the present document may be used for regulatory (Type Approval) purposes.

The present document has been prepared under Commission's standardisation request C(2015) 5376 [i.1] final to provide one voluntary means of conforming to the essential requirements of Directive 2014/53/EU [i.2] on the harmonisation of the laws of the Member States relating to the making available on the market of radio equipment and repealing Directive 1999/5/EC.

Once the present document is cited in the Official Journal of the European Union under that Directive, compliance with the normative clauses of the present document given in table A-1 confers, within the limits of the scope of the present document, a presumption of conformity with the corresponding essential requirements of that Directive and associated EFTA regulations.

The present document is part 14 of a multi-part deliverable. Full details of the entire series can be found in part 1 [i.7].

Proposed national transposition dates	
Date of latest announcement of this EN (doa):	3 months after ETSI publication
Date of latest publication of new National Standard or endorsement of this EN (dop/e):	6 months after doa
Date of withdrawal of any conflicting National Standard (dow):	18 months after doa

Modal verbs terminology

In the present document "**shall**", "**shall not**", "**should**", "**should not**", "**may**", "**need not**", "**will**", "**will not**", "**can**" and "**cannot**" are to be interpreted as described in clause 3.2 of the [ETSI Drafting Rules](#) (Verbal forms for the expression of provisions).

"**must**" and "**must not**" are **NOT** allowed in ETSI deliverables except when used in direct citation.

Introduction

The present document is part of a set of standards developed by ETSI that are designed to fit in a modular structure to cover radio equipment within the scope of the Radio Equipment Directive [i.2]. The present document is produced following the guidance in ETSI EG 203 336 [i.3] as applicable.

1 Scope

The present document specifies technical characteristics and methods of measurements for the types of equipment:

- 1) Base Station for Evolved Universal Terrestrial Radio Access (E-UTRA).
- 2) Base Station for Evolved Universal Terrestrial Radio Access (E-UTRA) with NB-IoT.
- 3) Base Station for NB-IoT standalone.

This radio equipment type is capable of operating in all or any part of the operating bands given in table 1-1. Unless stated otherwise, requirements specified for the TDD duplex mode apply for downlink and uplink operations in Frame Structure Type 2. NB-IoT is designed to operate in the E-UTRA operating bands 1, 3, 8, 20, 28 which are defined in table 1-1.

Table 1-1: E-UTRA Base Station operating bands

E-UTRA band	Direction of transmission	E-UTRA Base Station operating bands
1	Transmit	2 110 MHz to 2 170 MHz
	Receive	1 920 MHz to 1 980 MHz
3	Transmit	1 805 MHz to 1 880 MHz
	Receive	1 710 MHz to 1 785 MHz
7	Transmit	2 620 MHz to 2 690 MHz
	Receive	2 500 MHz to 2 570 MHz
8	Transmit	925 MHz to 960 MHz
	Receive	880 MHz to 915 MHz
20	Transmit	791 MHz to 821 MHz
	Receive	832 MHz to 862 MHz
22	Transmit	3 510 MHz to 3 590 MHz
	Receive	3 410 MHz to 3 490 MHz
28 (note 5)	Transmit	758 MHz to 803 MHz
	Receive	703 MHz to 748 MHz
31	Transmit	462,5 MHz to 467,5 MHz
	Receive	452,5 MHz to 457,5 MHz
32 (notes 1 and 2)	Transmit	1 452 MHz to 1 496 MHz
	Receive	N/A
33	Transmit and Receive	1 900 MHz to 1 920 MHz
34	Transmit and Receive	2 010 MHz to 2 025 MHz
38	Transmit and Receive	2 570 MHz to 2 620 MHz
40	Transmit and Receive	2 300 MHz to 2 400 MHz
42	Transmit and Receive	3 400 MHz to 3 600 MHz
43	Transmit and Receive	3 600 MHz to 3 800 MHz
46 (notes 3 and 4)	Transmit and Receive	5 150 MHz to 5 925 MHz
65	Transmit	2 110 MHz to 2 200 MHz
	Receive	1 920 MHz to 2 010 MHz
67	Transmit	738 MHz to 758 MHz
	Receive	N/A
68	Transmit	753 MHz to 783 MHz
	Receive	698 MHz to 728 MHz
69 (note 1)	Transmit	2 570 MHz to 2 620 MHz
	Receive	N/A
NOTE 1: Restricted to E-UTRA operation when carrier aggregation is configured. The downlink operating band is paired with the uplink operating band (external) of the carrier aggregation configuration that is supporting the configured Pcell.		
NOTE 2: Radio equipment in band 32 is only allowed to operate between 1 452 MHz and 1 492 MHz		
NOTE 3: This band is an unlicensed band restricted to licensed-assisted operation using Frame Structure Type 3. Radio equipment in band 46 is only allowed to operate between 5 150 MHz and 5 725 MHz.		
NOTE 4: In this version of the present document, restricted to E-UTRA DL operation when carrier aggregation is configured. Band 46 is divided into three sub-bands as in table 1-2.		
NOTE 5: Radio equipment in band 28 is only allowed to operate between 758 MHz to 791 MHz for the transmitter and between 703 MHz to 736 MHz for the receiver.		

Table 1-2: Sub-bands for band 46

E-UTRA Operating Band	Uplink (UL) operating band BS receive UE transmit	Downlink (DL) operating band BS transmit UE receive
	$F_{UL_low} - F_{UL_high}$	$F_{DL_low} - F_{DL_high}$
46a	5 150 MHz to 5 250 MHz	5 150 MHz to 5 250 MHz
46b	5 250 MHz to 5 350 MHz	5 250 MHz to 5 350 MHz
46c	5 470 MHz to 5 725 MHz	5 470 MHz to 5 725 MHz

The present document covers conducted requirements for E-UTRA Base Stations for 3GPP Release 8, 9, 10, 11, 12 and 13. Additionally, it includes the requirements for E-UTRA Base Station operating bands and E-UTRA CA operating bands from 3GPP Release 14.

NOTE: The relationship between the present document and essential requirements of article 3.2 of Directive 2014/53/EU [i.2] is given annex A.

2 References

2.1 Normative references

References are specific, identified by date of publication and/or edition number or version number. Only the cited version applies.

Referenced documents which are not found to be publicly available in the expected location might be found at <https://docbox.etsi.org/Reference/>.

NOTE: While any hyperlinks included in this clause were valid at the time of publication, ETSI cannot guarantee their long term validity.

The following referenced documents are necessary for the application of the present document.

- [1] ETSI TS 136 141 (V13.10.0) (01-2018): "LTE; Evolved Universal Terrestrial Radio Access (E-UTRA); Base Station (BS) conformance testing (3GPP TS 36.141 version 13.10.0 Release 13)".
- [2] ETSI TS 125 104 (V13.4.0) (03-2017): "Universal Mobile Telecommunications System (UMTS); Base Station (BS) radio transmission and reception (FDD) (3GPP TS 25.104 version 13.4.0 Release 13)".
- [3] ETSI TS 125 105 (V13.2.0) (07-2017): "Universal Mobile Telecommunications System (UMTS); Base Station (BS) radio transmission and reception (TDD) (3GPP TS 25.105 version 13.2.0 Release 13)".
- [4] ETSI TS 136 104 (V13.10.0) (01-2018): "LTE; Evolved Universal Terrestrial Radio Access (E-UTRA); Base Station (BS) radio transmission and reception (3GPP TS 36.104 version 13.10.0 Release 13)".
- [5] ETSI TS 125 141 (V13.4.0) (09-2017): "Universal Mobile Telecommunications System (UMTS); Base Station (BS) conformance testing (FDD) (3GPP TS 25.141 version 13.4.0 Release 13)".
- [6] ETSI TS 136 211 (V13.8.0) (01-2018): "LTE; Evolved Universal Terrestrial Radio Access (E-UTRA); Physical channels and modulation (3GPP TS 36.211 version 13.8.0 Release 13)".
- [7] ETSI EN 301 908-18 (V13.1.0) (07-2018): "IMT cellular networks; Harmonised Standard for access to radio spectrum; Part 18: E-UTRA, UTRA and GSM/EDGE Multi-Standard Radio (MSR) Base Station (BS)".
- [8] ETSI EN 301 893 (V2.1.1) (05-2017): "5 GHz RLAN; Harmonised Standard covering the essential requirements of article 3.2 of Directive 2014/53/EU".

- [9] ETSI TS 136 213 (V13.8.0) (01-2018): "LTE; Evolved Universal Terrestrial Radio Access (E-UTRA); Physical layer procedures (3GPP TS 36.213 version 13.8.0 Release 13)".

2.2 Informative references

References are either specific (identified by date of publication and/or edition number or version number) or non-specific. For specific references, only the cited version applies. For non-specific references, the latest version of the referenced document (including any amendments) applies.

NOTE: While any hyperlinks included in this clause were valid at the time of publication, ETSI cannot guarantee their long term validity.

The following referenced documents are not necessary for the application of the present document but they assist the user with regard to a particular subject area.

- [i.1] Commission implementing decision C(2015) 5376 final of 4.8.2015 on a standardisation request to the European Committee for Electrotechnical Standardisation and to the European Telecommunications Standards Institute as regards radio equipment in support of Directive 2014/53/EU of the European Parliament and of the Council.
- [i.2] Directive 2014/53/EU of the European parliament and of the council of 16 April 2014 on the harmonisation of the laws of the Member States relating to the making available on the market of radio equipment and repealing Directive 1999/5/EC.
- [i.3] ETSI EG 203 336 (V1.1.1) (08-2015): "Electromagnetic compatibility and Radio spectrum Matters (ERM); Guide for the selection of technical parameters for the production of Harmonised Standards covering article 3.1(b) and article 3.2 of Directive 2014/53/EU".
- [i.4] Recommendation ITU-R SM.329-12 (09-2012): "Unwanted emissions in the spurious domain".
- [i.5] ETSI TR 100 028 (all parts) (V1.4.1): "Electromagnetic compatibility and Radio spectrum Matters (ERM); Uncertainties in the measurement of mobile radio equipment characteristics".
- [i.6] Void.
- [i.7] ETSI EN 301 908-1: "IMT cellular networks; Harmonised Standard covering the essential requirements of article 3.2 of the Directive 2014/53/EU; Part 1: Introduction and common requirements".
- [i.8] Void.
- [i.9] ETSI TS 136 214 (V13.5.0) (09-2017): "LTE; Evolved Universal Terrestrial Radio Access (E-UTRA); Physical layer; Measurements (3GPP TS 36.214 version 13.5.0 Release 13)".
- [i.10] Commission Decision 2005/513/EC of 11 July 2005 on the harmonised use of radio spectrum in the 5 GHz frequency band for the implementation of Wireless Access Systems including Radio Local Area Networks (WAS/RLANs).
- [i.11] Commission Decision 2007/90/EC of 12 February 2007 amending Decision 2005/513/EC on the harmonised use of radio spectrum in the 5 GHz frequency band for the implementation of Wireless Access Systems including Radio Local Area Networks (WAS/RLANs).

3 Definition of terms, symbols and abbreviations

3.1 Terms

For the purposes of the present document, the following terms apply:

aggregated channel bandwidth: RF bandwidth in which a Base Station transmits and/or receives multiple contiguously aggregated carriers

NOTE: The Aggregated Channel Bandwidth is measured in MHz.

Base Station class: Wide Area Base Station, Medium Range Base Station, Local Area Base Station or Home Base Station, as declared by the manufacturer

Base Station RF bandwidth: RF bandwidth in which a Base Station transmits and/or receives single or multiple carrier(s) within a supported operating band

NOTE: In single carrier operation, the Base Station RF Bandwidth is equal to the channel bandwidth.

Base Station RF bandwidth edge: frequency of one of the edges of the Base Station RF Bandwidth

NOTE: Base Station RF Bandwidth edges are separated by the Base Station RF Bandwidth

carrier: modulated waveform conveying the E-UTRA or UTRA (WCDMA) physical channels

carrier aggregation: aggregation of two or more component carriers in order to support wider transmission bandwidths

carrier aggregation band: set of one or more operating bands across which multiple carriers are aggregated with a specific set of technical requirements

NOTE: Carrier aggregation band(s) for an E-UTRA BS is declared by the manufacturer according to the designations in tables 4.2.1-3 to 4.2.1-4.

channel bandwidth: RF bandwidth supporting a single E-UTRA RF carrier with the transmission bandwidth configured in the uplink or downlink of a cell

NOTE: The channel bandwidth is measured in MHz and is used as a reference for transmitter and receiver RF requirements.

channel edge: lowest or highest frequency of the E-UTRA carrier

NOTE: Channel edges are separated by the channel bandwidth.

clear channel assessment: mechanism used by an equipment to identify other transmissions in the channel

contiguous carriers: two or more carriers configured in a spectrum block where there are no RF requirements based on co-existence for un-coordinated operation within the spectrum block

contiguous spectrum: spectrum consisting of a contiguous block of spectrum with no sub-block gaps

downlink operating band: part of the operating band designated for downlink (BS transmit)

home Base Station: Base Stations characterized by requirements derived from femtocell scenarios

inter RF bandwidth gap: frequency gap between two consecutive Base Station RF Bandwidths that are placed within two supported operating bands

inter-band carrier aggregation: carrier aggregation of component carriers in different operating bands

NOTE: Carriers aggregated in each band can be contiguous or non-contiguous.

intra-band contiguous carrier aggregation: contiguous carriers aggregated in the same operating band

inter-band gap: frequency gap between two supported consecutive operating bands

intra-band non-contiguous carrier aggregation: non-contiguous carriers aggregated in the same operating band

Listen Before Talk (LBT): mechanism by which an equipment applies clear channel assessment (CCA) before using the channel

local area Base Station: Base Stations characterized by requirements derived from picocell scenarios with a BS to UE minimum coupling loss equal to 45 dB

lower sub-block edge: frequency at the lower edge of one sub-block

NOTE: It is used as a frequency reference point for both transmitter and receiver requirements.

maximum Base Station RF Bandwidth: maximum RF bandwidth supported by a BS within each supported operating band

maximum output power: mean power level per carrier of the Base Station measured at the antenna connector in a specified reference condition

maximum radio bandwidth: maximum frequency difference between the upper edge of the highest used carrier and the lower edge of the lowest used carrier

maximum throughput: maximum achievable throughput for a reference measurement channel

mean power: when applied to E-UTRA transmission, power measured in the channel bandwidth of the carrier where the period of measurement is at least one subframe (1 ms), unless otherwise stated

medium range Base Station: Base Stations characterized by requirements derived from micro cell scenarios with a BS to UE minimum coupling loss equal to 53 dB

multi-band Base Station: Base Station characterized by the ability of its transmitter and/or receiver to process two or more carriers in common active RF components simultaneously, where at least one carrier is configured at a different operating band (which is not a sub-band or superseding-band of another supported operating band) than the other carrier(s)

multi-band receiver: receiver characterized by the ability to process two or more carriers in common active RF components simultaneously, where at least one carrier is configured at a different operating band (which is not a sub-band or superseding-band of another supported operating band) than the other carrier(s)

multi-band transmitter: transmitter characterized by the ability to process two or more carriers in common active RF components simultaneously, where at least one carrier is configured at a different operating band (which is not a sub-band or superseding-band of another supported operating band) than the other carrier(s)

multi-carrier transmission configuration: set of one or more contiguous carriers that a BS is able to transmit simultaneously according to the manufacturer's specification

NB-IoT In-band operation: operation of NB-IoT utilizing the resource block(s) within a normal E-UTRA carrier

NB-IoT guard band operation: operation of NB-IoT utilizing the unused resource block(s) within a E-UTRA carrier's guard-band

NB-IoT standalone operation: operation of NB-IoT utilizing its own spectrum

EXAMPLE: The spectrum currently being used by GERAN systems as a replacement of one or more GSM carriers, as well as scattered spectrum for potential IoT deployment.

non-contiguous spectrum: spectrum consisting of two or more sub-blocks separated by sub-block gap(s)

operating band: frequency range (paired or unpaired) that is defined with a specific set of technical requirements, in which E-UTRA operates

NOTE: The operating band(s) for an E-UTRA BS is declared by the manufacturer according to the designations in table 1-1. Operating bands for E-UTRA are designated with Arabic numerals, while the corresponding operating bands for UTRA are designated with Roman numerals.

output power: mean power of one carrier of the Base Station, delivered to a load with resistance equal to the nominal load impedance of the transmitter

rated output power: mean power level per carrier that the manufacturer has declared to be available at the antenna connector

rated total output power: mean power level that the manufacturer has declared to be available at the antenna connector

resource block: physical resource consisting of a number of symbols in the time domain and a number of consecutive subcarriers spanning 180 kHz in the frequency domain

sub-band: part of the uplink and downlink frequency range of the operating band

sub-block: one contiguous allocated block of spectrum for transmission and reception by the same Base Station

NOTE: There may be multiple instances of sub-blocks within an Base Station RF Bandwidth.

sub-block bandwidth: bandwidth of one sub-block

sub-block gap: frequency gap between two consecutive sub-blocks within an Base Station RF Bandwidth, where the RF requirements in the gap are based on co-existence for un-coordinated operation

superseding-band: band that includes the whole of the uplink and downlink frequency range of the operating band

synchronized operation: operation of TDD in two different systems, where no simultaneous uplink and downlink occur

throughput: number of payload bits successfully received per second for a reference measurement channel in a specified reference condition

total RF bandwidth: maximum sum of Base Station RF Bandwidths in all supported operating bands

transmission bandwidth: bandwidth of an instantaneous transmission from a UE or BS, measured in resource block units

transmission bandwidth configuration: highest transmission bandwidth allowed for uplink or downlink in a given channel bandwidth, measured in resource block units

transmitter OFF period: time period during which the BS transmitter is not allowed to transmit

transmitter ON period: time period during which the BS transmitter is transmitting data and/or reference symbols, i.e. data subframes or DwPTS

transmitter transient period: time period during which the transmitter is changing from the OFF period to the ON period or vice versa

unsynchronized operation: operation of TDD in two different systems, where the conditions for synchronized operation are not met

uplink operating band: part of the operating band designated for uplink (BS receive)

upper sub-block edge: frequency at the upper edge of one sub-block

NOTE: It is used as a frequency reference point for both transmitter and receiver requirements.

wide area Base Station: Base Stations characterized by requirements derived from Macro Cell scenarios with a BS to UE minimum coupling loss equal to 70 dB

NOTE: This Base Station class has the same requirements as the general purpose Base Station in 3GPP Release 8.

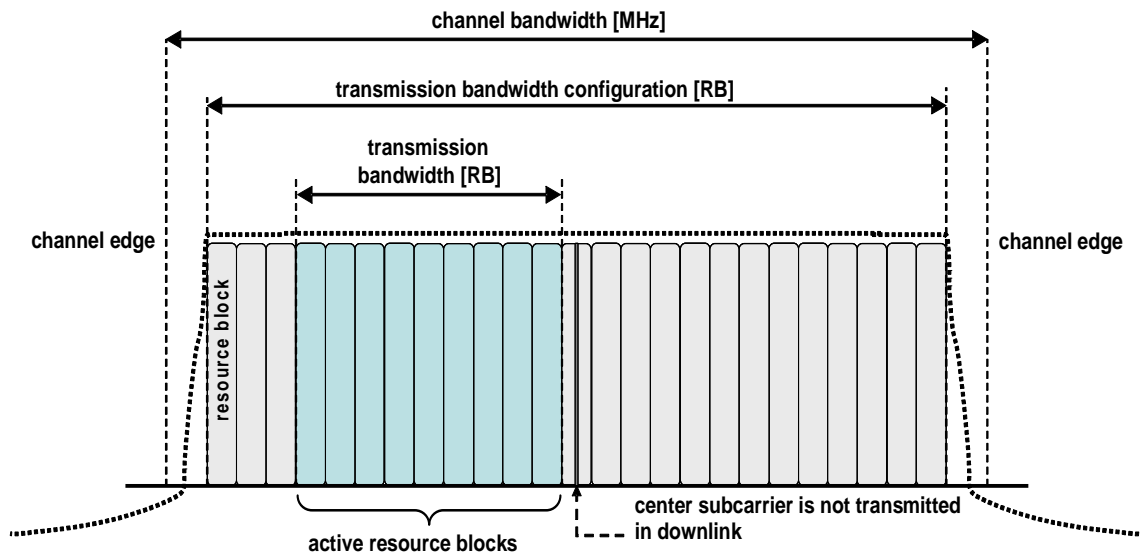

Figure 3.1-1: Channel bandwidth and transmission bandwidth configuration for one E-UTRA carrier

Figure 3.1-2 illustrates the Aggregated Channel Bandwidth for intra-band contiguous carrier aggregation.

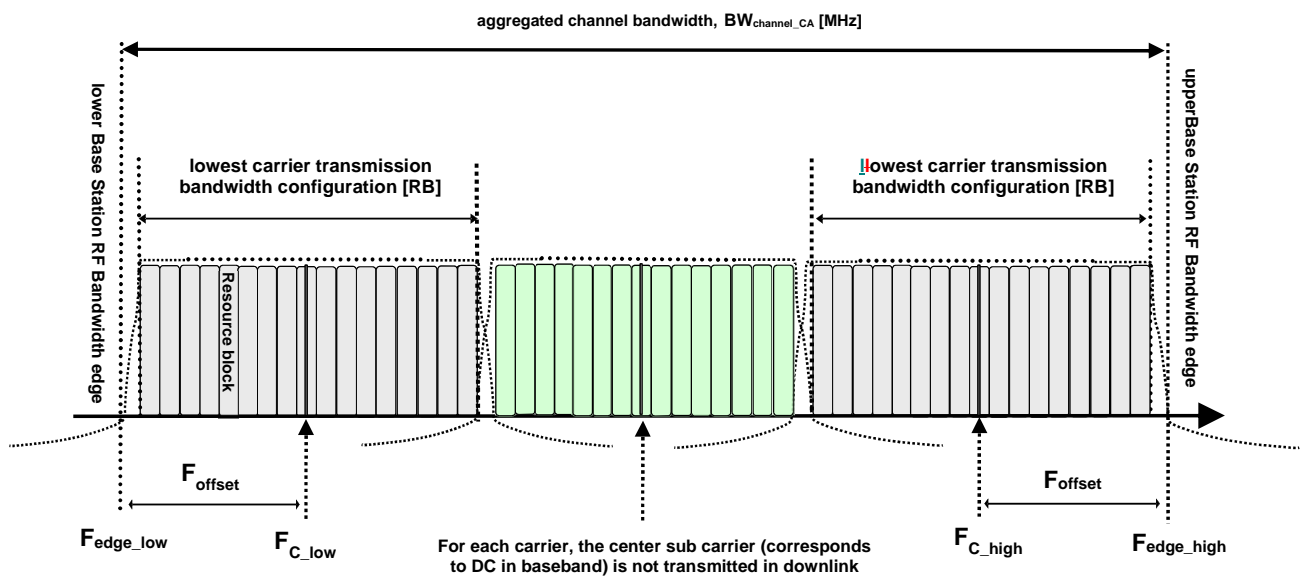

Figure 3.1-2: Aggregated Channel Bandwidth for intra-band carrier aggregation

The lower edge of the Aggregated Channel Bandwidth ($BW_{\text{Channel_CA}}$) is defined as $F_{\text{edge_low}} = F_{C_low} - F_{\text{offset}}$. The upper edge of the Aggregated Channel Bandwidth is defined as $F_{\text{edge_high}} = F_{C_low} + F_{\text{offset}}$. The Aggregated Channel Bandwidth, $BW_{\text{Channel_CA}}$, is defined as follows:

$$BW_{\text{Channel_CA}} = F_{\text{edge_high}} - F_{\text{edge_low}} \text{ [MHz]}$$

Figure 3.1-3 illustrates the sub-block bandwidth for a BS operating in non-contiguous spectrum.

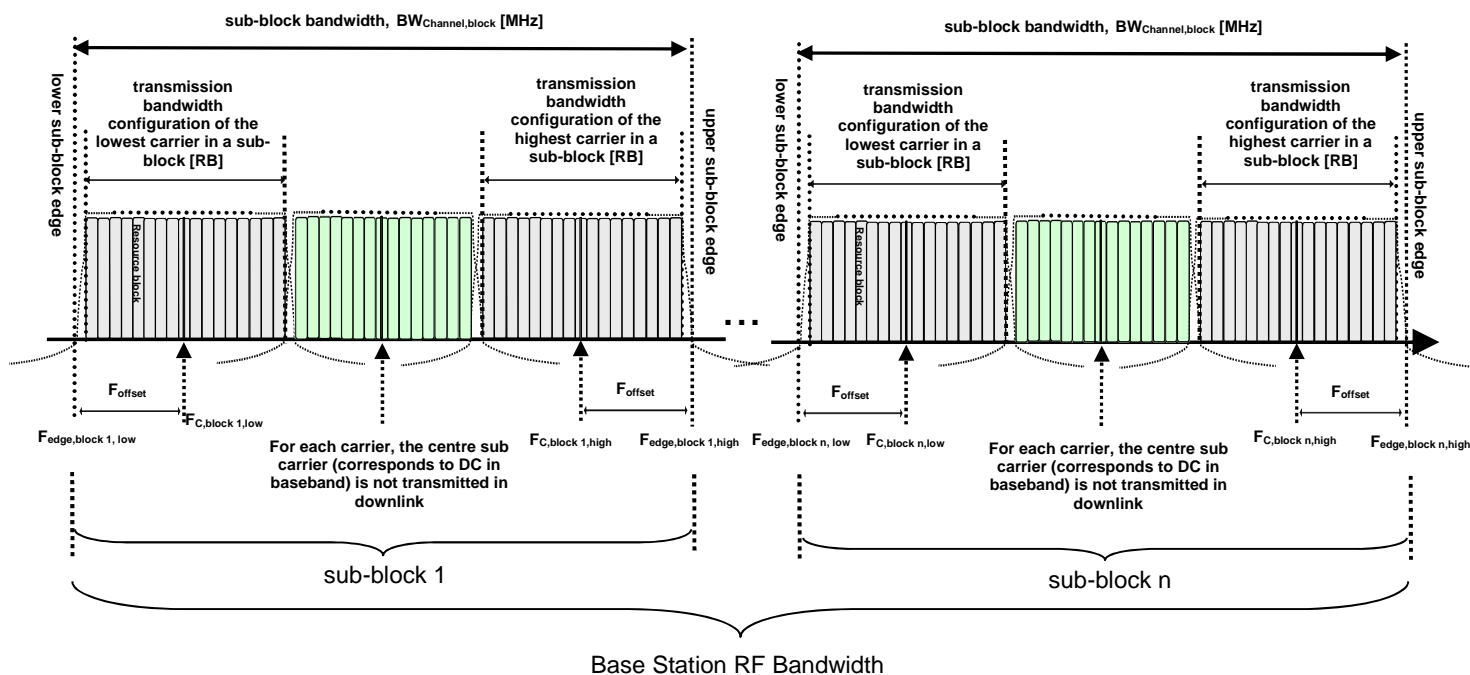

Figure 3.1-3: Sub-block bandwidth for intra-band non-contiguous spectrum

The lower sub-block edge of the sub-block bandwidth ($BW_{Channel,block}$) is defined as $F_{edge,block,low} = F_{C,block,low} - F_{offset}$. The upper sub-block edge of the sub-block bandwidth is defined as $F_{edge,block,high} = F_{C,block,high} + F_{offset}$. The sub-block bandwidth, $BW_{Channel,block}$, is defined as follows:

$$BW_{Channel,block} = F_{edge,block,high} - F_{edge,block,low} \text{ [MHz]}$$

F_{offset} is defined in table 3.1-1 below where $BW_{Channel}$ is defined in table 5.6-1 of ETSI TS 136 141 [1].

Table 3.1-1: Definition of F_{offset}

Channel bandwidth of the lowest or highest carrier: $BW_{Channel}$ [MHz]	F_{offset} [MHz]
5, 10, 15, 20	$BW_{Channel}/2$
NOTE 1: F_{offset} is calculated separately for each Base Station RF Bandwidth edge/sub-block edge.	
NOTE 2: The values of $BW_{Channel_CA}/BW_{Channel,block}$ for UE and BS are the same if the channel bandwidths of lowest and the highest component carriers are identical.	

Table 3.1-2: Definition of F_{offset} for NB-IoT standalone operation

Lowest or Highest Carrier	F_{offset}
Standalone NB-IoT	200 kHz

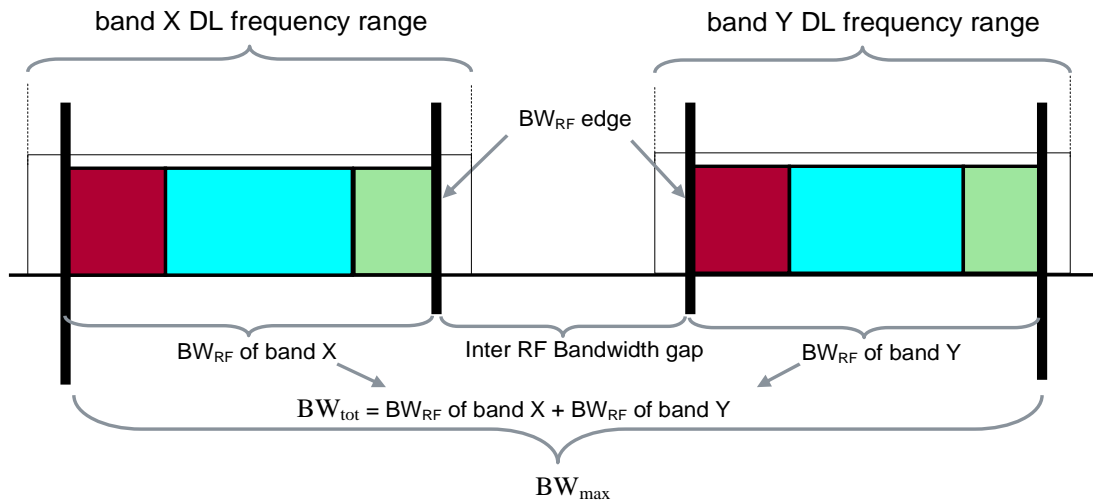

Figure 3.1-4: Maximum Radio Bandwidth BW_{max} and Total RF Bandwidth BW_{tot} for multi-band Base Station

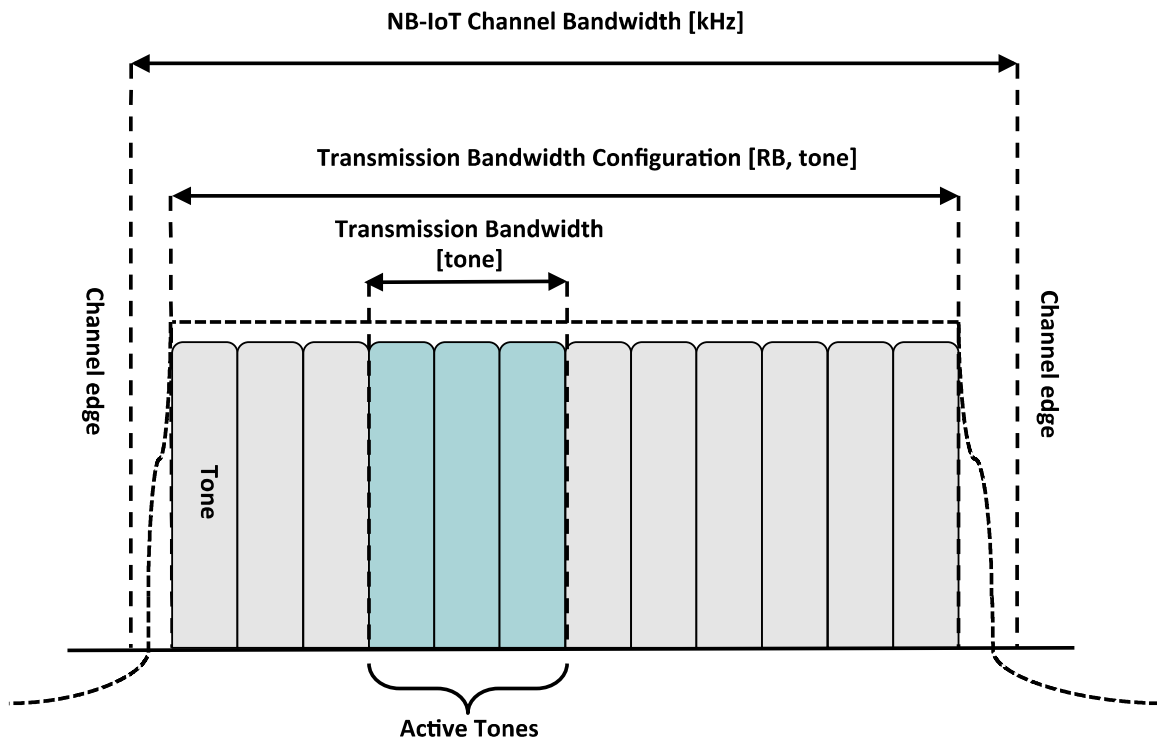

Figure 3.1-5: Definition of Channel Bandwidth and Transmission Bandwidth Configuration for NB-IoT standalone operation, see clause 5.6 in ETSI TS 136 141 [1]

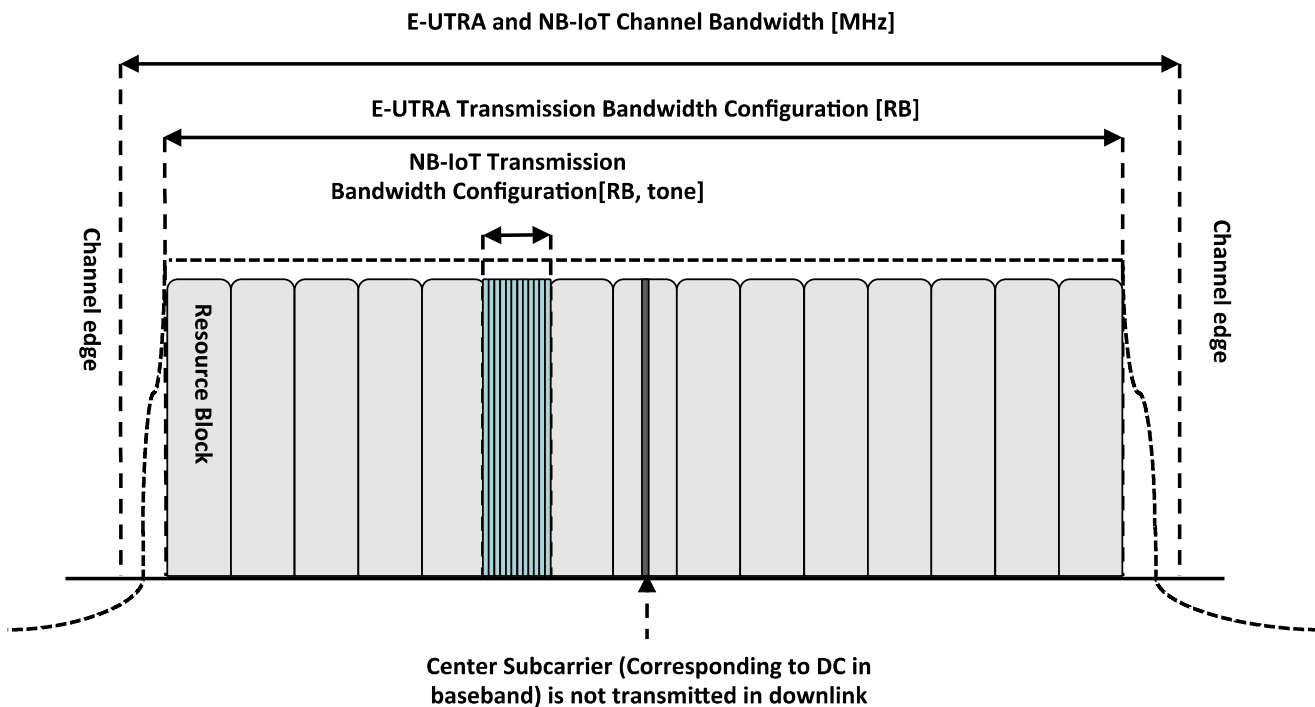

Figure 3.1-6: Definition of Channel Bandwidth and Transmission Bandwidth Configuration for NB-IoT in-band operation, see clause 5.6 in ETSI TS 136 141 [1]

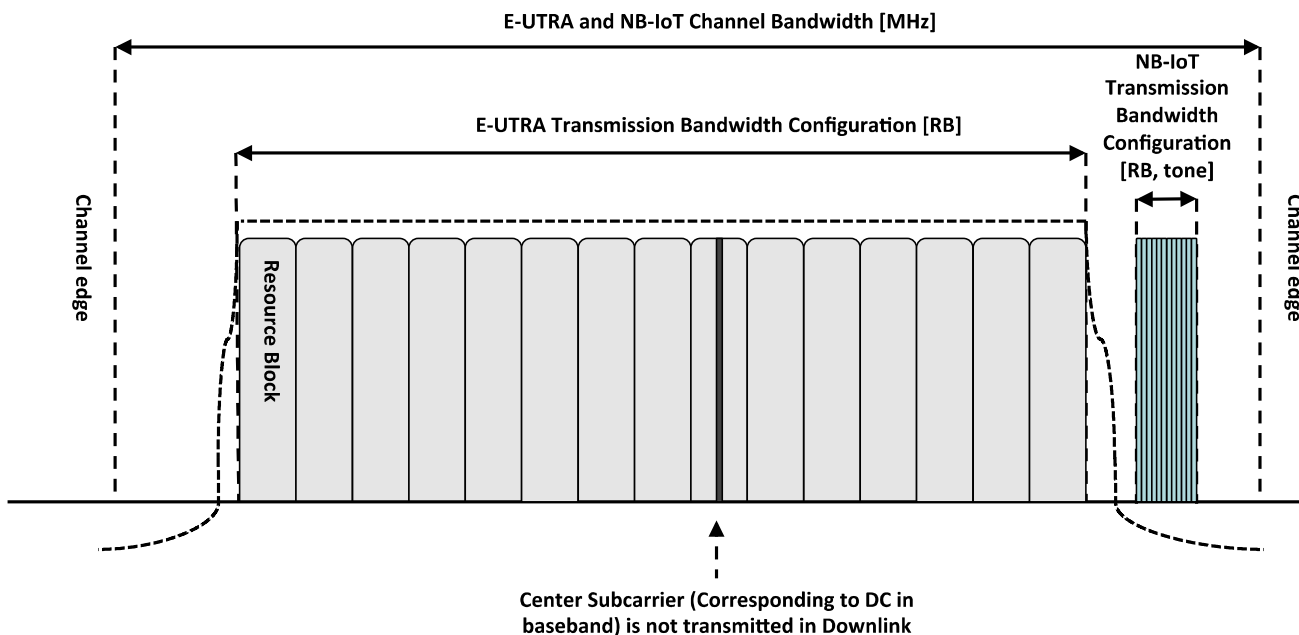

Figure 3.1-7: Definition of Channel Bandwidth and Transmission Bandwidth Configuration for NB-IoT guard band operation, see clause 5.6 in ETSI TS 136 141 [1]

3.2 Symbols

For the purposes of the present document, the following symbols apply:

- B_{RFBW} Maximum Base Station RF Bandwidth located at the bottom of the supported frequency range in the operating band
- $BW_{Channel}$ Channel bandwidth
- $BW_{Channel, block}$ Sub-block bandwidth, expressed in MHz. $BW_{Channel, block} = F_{edge, block, high} - F_{edge, block, low}$

BW_{Config}	Transmission bandwidth configuration, expressed in MHz, where $BW_{\text{Config}} = N_{\text{RB}} \times 180 \text{ kHz}$ in the uplink and $BW_{\text{Config}} = 15 \text{ kHz} + N_{\text{RB}} \times 180 \text{ kHz}$ in the downlink
BW_{max}	Maximum Radio Bandwidth
BW_{tot}	Total RF Bandwidth
$\text{CPICH } \hat{E}_c$	Common Pilot Channel code power (on the adjacent channel)
$\text{CRS } \hat{E}_c$	Reference Signal received power per resource element
f	Frequency
Δf	Separation between the channel edge frequency and the nominal -3 dB point of the measuring filter closest to the carrier frequency
Δf_{max}	The largest value of Δf used for defining the requirement
F_C	Carrier centre frequency
$F_{C,\text{block, high}}$	Centre frequency of the highest transmitted/received carrier in a sub-block
$F_{C,\text{block, low}}$	Centre frequency of the lowest transmitted/received carrier in a sub-block
$F_{C,\text{high}}$	The carrier centre frequency of the highest carrier, expressed in MHz
$F_{C,\text{low}}$	The carrier centre frequency of the lowest carrier, expressed in MHz
$F_{\text{edge,low}}$	The lower edge of Aggregated Channel Bandwidth, expressed in MHz, $F_{\text{edge,low}} = F_{C,\text{low}} - F_{\text{offset}}$
$F_{\text{edge,high}}$	The upper edge of Aggregated Channel Bandwidth, expressed in MHz, $F_{\text{edge,high}} = F_{C,\text{high}} + F_{\text{offset}}$
$F_{\text{edge,block,low}}$	The lower sub-block edge, where $F_{\text{edge,block,low}} = F_{C,\text{block,low}} - F_{\text{offset}}$
$F_{\text{edge,block,high}}$	The upper sub-block edge, where $F_{\text{edge,block,high}} = F_{C,\text{block,high}} + F_{\text{offset}}$
F_{offset}	Frequency offset from $F_{C,\text{high}}$ to the upper Base Station RF Bandwidth edge or from $F_{C,\text{block, high}}$ to the upper sub-block edge, $F_{C,\text{low}}$ to the lower Base Station RF Bandwidth edge or from $F_{C,\text{block, low}}$ to the lower sub-block edge
F_{filter}	Filter centre frequency
$f_{\text{interferer}}$	Centre frequency of the interfering signal
f_{offset}	Separation between the channel edge frequency and the centre of the measuring filter
$f_{\text{offset,max}}$	The maximum value of f_{offset} used for defining the requirement
$F_{\text{UL,low}}$	The lowest frequency of the uplink operating band (see table 1-1)
$F_{\text{UL,high}}$	The highest frequency of the uplink operating band (see table 1-1)
I_{oh}	Total received power density excluding own Home BS signal
I_{uant}	E-Node B internal logical interface between the implementation specific O&M function and the RET antennas and TMAs control unit function of the E-Node B
N_{RB}	Transmission bandwidth configuration, expressed in units of Resource Blocks
$N_{\text{RB}}^{\text{DL}}$	The number of downlink resource blocks in the downlink
$N_{\text{sc}}^{\text{RB}}$	The number of subcarriers in a resource block $N_{\text{sc}}^{\text{RB}} = 12$
P	Antenna port number
(P_i)	Power of the signal at antenna connector i
(P_s)	Sum of the power for all antenna connectors
$P_{\text{max,c}}$	Maximum carrier output power
$P_{\text{NB-IoTcarrier}}$	Power level of the NB-IoT carrier adjacent to the Base Station RF Bandwidth edge
P_{out}	Output power
$P_{\text{rated,c}}$	Rated output power (per carrier)
P_{REFSENS}	Reference sensitivity level
T_{RFBW}	Maximum Base Station RF Bandwidth located at the top of the supported frequency range in the operating band
W_{gap}	Sub-block gap or Inter RF Bandwidth gap size

3.3 Abbreviations

For the purposes of the present document, the following abbreviations apply:

ACLR	Adjacent Channel Leakage Ratio
ACS	Adjacent Channel Selectivity
ATT	Attenuator
AWGN	Additive White Gaussian Noise
B	Bottom RF channel
BRFBW	Bottom Radio Frequency channel BandWidth
BS	Base Station
BTS	Base Transceiver Station
BW	BandWidth
C	Contiguous
CA	Carrier Aggregation
CACLR	Cumulative ACLR
CCA	Clear Channel Assessment
CPICH	Common Pilot Channel
CRS	Cell specific Reference Signal
CSG	Closed Subscriber Group
CW	Continuous Wave
DC	Direct Current
DFS	Dynamic Frequency Sharing
DL	Down Link
DTT	Digital Terrestrial Television
DwPTS	Downlink part of the special subframe
EARFCN	E-UTRA Absolute Radio Frequency Channel Number
EC	European Commission
ECC	Electronic Communication Committee
EFTA	European Free Trade Association
ERM	Electromagnetic compatibility and Radio spectrum Matters
E-TM	E-UTRA Test Model
EUT	Equipment Under Test
E-UTRA	Evolved UMTS Terrestrial Radio Access
FDD	Frequency Division Duplex
FRC	Fixed Reference Channel
GSM	General System for Mobile communications
IMT	International Mobile Telecommunications
ITU-R	International Telecommunication Union - Radiocommunication
LBT	Listen Before Talk
LTE	Long Term Evolution
M	Middle RF channel
MBT	Multi-Band Testing
MCOT	Maximum Channel Occupancy Time
MS	Mobile Station
MSG	Mobile Standards Group
MSR	Multi-Standard Radio
MUE	Macro UE
NB-IoT	Narrowband - Internet of Things
PDSCH	Physical Downlink Shared CHannel
PRB	Physical Resource Block
RAT	Radio Access Technology
RB	Resource Block
RF	Radio Frequency
RFBW	Radio Frequency BandWidth
RMS	Root Mean Square
RRC	Root Raised Cosine
RX	Receive
SBT	Single Band Testing
T	Top RF channel
TDD	Time Division Duplex

TFES	Task Force for European Standards for IMT
TM	Test Model
TRFBW	Top Radio Frequency channel BandWidth
TX	Transmit
UE	User Equipment
UL	UpLink
UMTS	Universal Mobile Telecommunications System
UTRA	UMTS Terrestrial Radio Access

4 Technical requirements specifications

4.1 Environmental profile

The technical requirements of the present document apply under the environmental profile for operation of the equipment, which shall be declared by the manufacturer. The equipment shall comply with all the technical requirements of the present document, which are identified as applicable in annex A, at all times when operating within the boundary limits of the declared operational environmental profile.

The operational environmental profile declared by the manufacturer shall at least contain all environmental conditions in the test environments referenced from the essential radio test suites in clause 5.

4.2 Conformance requirements

4.2.1 Introduction

The requirements in the present document are based on the assumption that the operating band (see table 1-1) is shared between systems of the IMT family (for band 3 and 8 also GSM) or systems having compatible characteristics.

To meet the essential requirement under article 3.2 of Directive 2014/53/EU [i.2] for IMT Base Stations (BS), a set of essential parameters in addition to those in ETSI EN 301 908-1 [i.7] have been identified. Table 4.2.1-1 provides a cross reference between these essential parameters and the corresponding technical requirements for equipment within the scope of the present document.

Table 4.2.1-1: Cross references

Essential parameter	Corresponding technical requirements	Corresponding test suite
Transmitter spectrum mask	4.2.2 Operating band unwanted emissions	5.3.1
Transmitter unwanted emissions in the out of band domain	4.2.3 Adjacent Channel Leakage power Ratio (ACLR)	5.3.2
	4.2.11 Home BS output power for adjacent UTRA channel protection	5.3.10
	4.2.12 Home BS output power for adjacent E-UTRA channel protection	5.3.11
	4.2.13 Home BS output power for co-channel E-UTRA protection	5.3.12
Transmitter unwanted emissions in the spurious domain	4.2.4 Transmitter spurious emissions	5.3.3
Transmitter power accuracy	4.2.5 Base Station maximum output power	5.3.4
	4.2.17 Base Station output power in band 46	5.3.16
Transmitter intermodulation attenuation	4.2.6 Transmit intermodulation	5.3.5
Receiver unwanted emissions in the spurious domain	4.2.7 Receiver spurious emissions	5.3.6
Receiver blocking	4.2.8 Blocking characteristics	5.3.7
Receiver desensitization		
Receiver radio-frequency intermodulation	4.2.9 Receiver intermodulation characteristics	5.3.8
Receiver adjacent channel selectivity	4.2.10 Adjacent Channel Selectivity (ACS) and narrow-band blocking	5.3.9
Receiver sensitivity	4.2.14 Reference sensitivity level	5.3.13
Listen before talk (LBT)	4.2.15 Downlink channel access procedure	5.3.14
	4.2.16 Dynamic Frequency Selection (DFS)	5.3.15

The manufacturer shall declare the following:

- The operating band(s) supported by the Base Station for carrier aggregation according to table 4.2.1-3.
- The supported RF configurations according to clause 4.6.8 of ETSI TS 136 141 [1].
- The intended Base Station class according to clause 4.2 of ETSI TS 136 141 [1].
- The NB-IoT parameters according to clause 4.6.9 and 4.6.10 of ETSI TS 136 141 [1].

The technical requirements in the present document apply for the declared BS class and the operating band(s) as outlined for each requirement. For a Base Station supporting more than one operating band, conformance testing for each technical requirement in clause 5 shall be performed for each operating band.

For NB-IoT guard band operation, the NB-IoT edge should be placed at least 200 kHz away from the E-UTRA channel edge, in absence of an agreement between operators using adjacent blocks. NB-IoT guard band operation is only foreseen within E-UTRA channel bandwidths of 10 MHz and higher. This statement is provided for information and does not have any impact on the conformance requirements or essential radio test suites in the present document.

When the BS is configured to receive multiple carriers, all the throughput requirements are applicable for each received carrier. For ACS, blocking and intermodulation characteristics, the negative offsets of the interfering signal apply relative to the lower Base Station RF Bandwidth edge and positive offsets of the interfering signal apply relative to the upper Base Station RF Bandwidth edge.

For BS capable of multi-band operation, the technical requirements in present clause shall apply for each supported operating band unless otherwise stated. For some requirements it is explicitly stated that specific additions or exclusions to the requirement apply for BS capable of multi-band operation.

For BS capable of multi-band operation, various structures in terms of combinations of different transmitter and receiver implementations (multi-band or single band) with mapping of transceivers to one or more antenna port(s) in different ways are possible. In the case where multiple bands are mapped on separate antenna connectors, the following shall apply:

- Single-band ACLR, operating band unwanted emissions, transmitter spurious emissions, transmitter intermodulation and receiver spurious emissions requirements shall apply to each antenna connector.

- If the BS is configured for single-band operation, single-band requirements shall apply to the antenna connector configured for single-band operation and no exclusions or provisions for multi-band capable BS are applicable. Single-band requirements are tested separately at the antenna connector configured for single-band operation, with all other antenna connectors terminated.

For a BS capable of multi-band operation supporting bands for TDD, the RF requirements in the present document assume synchronized operation, where no simultaneous uplink and downlink occur between the supported operating bands.

The RF requirements in the present document do not apply for multi-band operation supporting bands for both FDD and TDD.

The technical requirements also apply to the BS configurations described in annex B.

For an E-UTRA BS additionally conforming to ETSI EN 301 908-18 [7], conformance with the technical requirements listed in table 4.2.1-1 can equally be demonstrated through the corresponding technical requirements and test suites in ETSI EN 301 908-18 [7], as listed in table 4.2.1-2.

When conformance is demonstrated through the test suites in ETSI EN 301 908-18 [7] for these technical requirements, the corresponding test suites in the present document need not be performed.

Table 4.2.1-2: Alternative technical requirements and test suites in ETSI EN 301 908-18 [7] that can equally be used for demonstrating BS conformance

Technical requirement in the present document	Corresponding technical requirements in ETSI EN 301 908-18 [7]	Corresponding test suites in ETSI EN 301 908-18 [7]
4.2.2 Operating band unwanted emissions	4.2.2 Operating band unwanted emissions	5.3.1 Operating band unwanted emissions
4.2.3 Adjacent Channel Leakage power Ratio (ACLR)	(note 1)	(note 1)
4.2.4 Transmitter spurious emissions	4.2.4 Transmitter spurious emissions	5.3.3 Transmitter spurious emissions
4.2.5 Base Station maximum output power	4.2.5 Base station maximum output power	5.3.4 Base station maximum output power
4.2.6 Transmit intermodulation	4.2.6 Transmit intermodulation	5.3.5 Transmit intermodulation
4.2.7 Receiver spurious emissions	4.2.7 Receiver spurious emissions	5.3.6 Receiver spurious emissions
4.2.8 Blocking characteristics	4.2.8 In-band blocking 4.2.9 Out-of-band blocking	5.3.7 In-band blocking 5.3.8 Out-of-band blocking
4.2.9 Receiver intermodulation characteristics	4.2.10 Receiver intermodulation characteristics	5.3.9 Receiver intermodulation characteristics
4.2.10 Adjacent Channel Selectivity (ACS) and narrow-band blocking	4.2.11 Narrowband blocking	5.3.10 Narrowband blocking
4.2.14 Reference sensitivity level	(See note 2)	(See note 2)
NOTE 1: Conformance with the E-UTRA ACLR requirement is for an MSR BS demonstrated through the requirement in clause 4.2.3 of the present document and the corresponding test suite in clause 5.3.2.		
NOTE 2: Conformance with the E-UTRA reference sensitivity requirement is for an MSR BS demonstrated through the requirement in clause 4.2.14 of the present document and the corresponding test suite in clause 5.3.13.		

E-UTRA is designed to operate for the carrier aggregation bands defined in tables 4.2.1-3 to 4.2.1-6.

Table 4.2.1-3: Intra-band contiguous carrier aggregation bands

CA band	E-UTRA operating band
CA_1	1
CA_3	3
CA_7	7
CA_8	8
CA_38	38
CA_40	40
CA_42	42

Table 4.2.1-4: Inter-band carrier aggregation bands (two bands)

A Band	E-UTRA operating bands
CA_1-3	1
	3
CA_1-3-3	1
	3
CA_1-7	1
	7
CA_1-7-7	1
	7
CA_1-8	1
	8
CA_1-20	1
	20
CA_1-28	1
	28
CA_1-40	1
	40
CA_1-42	1
	42
CA_1-46	1
	46
CA_3-7	3
	7
CA_3-3-7	3
	7
CA_3-3-7-7	3
	7
CA_3-7-7	3
	7
CA_3-8	3
	8
CA_3-3-8	3
	8
CA_3-20	3
	20
CA_3-3-20	3
	20
CA_3-28	3
	28
CA_3-40	3
	40
CA_3-40-40	3
	40
CA_3-42	3
	42
CA_3-46	3
	46
CA_3-69	3
	69
CA_7-8	7
	8
CA_7-7-8	7
	8
CA_7-20	7
	20
CA_7-22	7
	22
CA_7-28	7
	28
CA_7-32	7
	32
CA_7-40	7
	40

A Band	E-UTRA operating bands
CA_7-42	7
	42
CA_7-42-42	7
	42
CA_7_46	7
	46
CA_8-20	8
	20
CA_8-28	8
	28
CA_8-40	8
	40
CA_8-42	8
	42
CA_8-46	8
	46
CA_20-32	20
	32
CA_20-38	20
	38
CA_20_40	20
	40
CA_20-42	20
	42
CA_20-42-42	20
	42
CA_20-42-42	20
	42
CA_20-67	20
	67
CA_28-40	28
	40
CA_28-42	28
	42
CA_42_46	42
	46

Table 4.2.1-5: Inter-band carrier aggregation bands (three bands)

CA Band	E-UTRA operating bands
CA_1-3-7	1
	3
	7
CA_1-3-7-7	1
	3
	7
CA_1-3-8	1
	3
	8
CA_1-3-3-8	1
	3
	8
CA_1-3-20	1
	3
	20
CA_1-3-28	1
	3
	28
CA_1-3-40	1
	3
	40

CA Band	E-UTRA operating bands
CA_1-3-42	1
	3
	42
CA_1-7-8	1
	7
	8
CA_1-7-20	1
	7
	20
CA_1-7-28	1
	7
	28
CA_1-7-40	1
	7
	40
CA_1-7-42	1
	7
	42
CA_1-7-46	1
	7
	46
CA_1-20-42	1
	20
	42
CA_1-28-42	1
	28
	42
CA_1-8-28	1
	8
	28
CA_1-8-40	1
	8
	40
CA_3-7-8	3
	7
	8
CA_3-3-7-8	3
	7
	8
CA_3-7-7-8	3
	7
	8
CA_3-3-7-7-8	3
	7
	8
CA_3-7-20	3
	7
	20
CA_3-7-28	3
	7
	28
CA_3-7-42	3
	7
	32
CA_3-7-38	3
	7
	38
CA_3-7-40	3
	7
	40
CA_3-7-42	3
	7
	42

CA Band	E-UTRA operating bands
CA_3-8-28	3
	8
	28
CA_3-8-40	3
	8
	40
CA_3-20-32	3
	20
	32
CA_3-20-42	3
	20
	42
CA_3-28-40	3
	28
	40
CA_3-28-42	3
	28
	42
CA_7-8-20	7
	8
	20
CA_7-20-38	7
	20
	38
CA_7-20-42	7
	20
	42

Table 4.2.1-6: Intra-band non-contiguous carrier aggregation bands (with two sub-blocks)

CA Band	E-UTRA operating bands
CA_3-3	1
CA_7-7	7
CA_40-40	40
CA_42-42	42

Table 4.2.1-7: Inter-band carrier aggregation bands (four bands)

CA Band	E-UTRA operating bands
CA_1-3-7-8	1
	3
	7
	8
CA_1-3-7-20	1
	3
	7
	20
CA_1-3-7-28	1
	3
	7
	28
CA_1-3-7-42	1
	3
	7
	42
CA_1-3-8-40	1
	3
	8
	40

Table 4.2.1-8: Inter-band carrier aggregation bands (five bands)

CA Band	E-UTRA operating bands
CA_1-3-7-20-42	1
	3
	7
	20
	42

4.2.2 Operating band unwanted emissions

4.2.2.1 Definition

Unwanted emissions consist of out-of-band emissions and spurious emissions (Recommendation ITU-R SM.329-12 [i.4]). Out of band emissions are emissions immediately outside the channel bandwidth resulting from the modulation process and non-linearity in the transmitter but excluding spurious emissions. The out-of-band emissions requirement for the BS transmitter is specified both in terms of Adjacent Channel Leakage power Ratio (ACLR) and Operating band unwanted emissions.

Unless otherwise stated, the Operating band unwanted emission limits are defined from 10 MHz below the lowest frequency of each supported downlink operating band up to 10 MHz above the highest frequency of each supported downlink operating band (see table 1-1).

The requirements shall apply whatever the type of transmitter considered (single carrier or multi-carrier) and for all transmission modes foreseen by the manufacturer's specification. In addition, for a BS operating in non-contiguous spectrum, it shall apply inside any sub-block gap. In addition, for a BS operating in multiple bands, the requirements shall apply inside any Inter RF Bandwidth gap.

For a BS supporting multi-carrier, the unwanted emissions requirements apply to channel bandwidths of the outermost carrier larger than or equal to 5 MHz.

For a multicarrier E-UTRA BS configured for intra-band contiguous or non-contiguous carrier aggregation the definitions above apply to the lower edge of the carrier transmitted at the lowest carrier frequency and the higher edge of the carrier transmitted at the highest carrier frequency within a specified operating band.

For BS capable of multi-band operation where multiple bands are mapped on separate antenna connectors, the single-band requirements apply and the cumulative evaluation of the emission limit in the Inter RF Bandwidth gap are not applicable.

For a BS supporting E-UTRA with guard band NB-IoT operation, the operating band unwanted emissions requirements apply to E-UTRA carrier with channel bandwidth larger than or equal to 5 MHz.

The requirements for BS that supports standalone NB-IoT are in clause 4.2.2.2.11.

For an E-UTRA BS additionally conforming to ETSI EN 301 908-18 [7], either the requirement of the present clause or the Operating band unwanted emissions requirement in clause 4.2.2 of ETSI EN 301 908-18 [7] can be equally applied, as listed in table 4.2.1-2.

4.2.2.2 Limits

4.2.2.2.0 General

For a Wide Area BS the requirement shall apply outside the Base Station RF Bandwidth. In addition, for a Wide Area BS operating in non-contiguous spectrum, it shall apply inside any sub-block gap. In addition, for a Wide Area BS operating in multiple bands, it applies inside any Inter RF Bandwidth gap.

For a Medium Range BS the requirement shall apply outside the Base Station RF Bandwidth. In addition, for a Medium Range BS operating in non-contiguous spectrum, it shall apply inside any sub-block gap. In addition, for a Medium Range BS operating in multiple bands, it applies inside any Inter RF Bandwidth gap.

For a Local Area BS the requirement shall apply outside the Base Station RF Bandwidth. In addition, for a Local Area BS operating in non-contiguous spectrum, it shall apply inside any sub-block gap. In addition, for a Local Area BS operating in multiple bands, it applies inside any Inter RF Bandwidth gap.

Outside the Base Station RF Bandwidth, emissions shall not exceed the maximum levels specified in the tables 4.2.2.2.1-1 to 4.2.2.2.5-3A and tables 4.2.2.2.8-1 to 4.2.2.2.8-12, where:

- Δf is the separation between the channel edge frequency and the nominal -3 dB point of the measuring filter closest to the carrier frequency.
- f_{offset} is the separation between the channel edge frequency and the centre of the measuring filter.
- $f_{\text{offset}_{\text{max}}}$ is the offset to the frequency 10 MHz outside the downlink operating band.
- Δf_{max} is equal to $f_{\text{offset}_{\text{max}}}$ minus half of the bandwidth of the measuring filter.

For BS operating in multiple bands, inside any Inter RF Bandwidth gaps with $W_{\text{gap}} < 20$ MHz, emissions shall not exceed the cumulative sum of the test requirements specified at the Base Station RF Bandwidth edges on each side of the Inter RF Bandwidth gap. The test requirement for Base Station RF Bandwidth edge is specified in tables 4.2.2.2.1-1 to 4.2.2.2.1-3, where in this case:

- Δf is the separation between the Base Station RF Bandwidth edge frequency and the nominal -3 dB point of the measuring filter closest to the Base Station RF Bandwidth edge.
- f_{offset} is the separation between the Base Station RF Bandwidth edge frequency and the centre of the measuring filter.
- $f_{\text{offset}_{\text{max}}}$ is equal to the Inter RF Bandwidth gap minus half of the bandwidth of the measuring filter.
- Δf_{max} is equal to $f_{\text{offset}_{\text{max}}}$ minus half of the bandwidth of the measuring filter.

For BS capable of multi-band operation where multiple bands are mapped on the same antenna connector, the operating band unwanted emission limits apply also in a supported operating band without any carrier transmitted, in the case where there are carrier(s) transmitted in another supported operating band. In this case, no cumulative limit is applied in the inter-band gap between a supported downlink operating band with carrier(s) transmitted and a supported downlink operating band without any carrier transmitted and:

- In case the inter-band gap between a supported downlink operating band with carrier(s) transmitted and a supported downlink operating band without any carrier transmitted is less than 20 MHz, $f_{\text{offset}_{\text{max}}}$ shall be the offset to the frequency 10 MHz outside the outermost edges of the two supported downlink operating bands and the operating band unwanted emission limit of the band where there are carriers transmitted, as defined in the tables of the present clause, shall apply across both downlink bands.
- In other cases, the operating band unwanted emission limit of the band where there are carriers transmitted, as defined in the tables of the present clause for the largest frequency offset (Δf_{max}), shall apply from 10 MHz below the lowest frequency, up to 10 MHz above the highest frequency of the supported downlink operating band without any carrier transmitted.

In addition inside any sub-block gap for a BS operating in non-contiguous spectrum, measurement results shall not exceed the cumulative sum of the test requirements specified for the adjacent sub-blocks on each side of the sub-block gap. The test requirement for each sub-block is specified in tables 4.2.2.2.1-1 to 4.2.2.2.5-3A and tables 4.2.2.2.8-1 to 4.2.2.2.8-12, where in this case:

- Δf is the separation between the sub-block edge frequency and the nominal -3 dB point of the measuring filter closest to the sub-block edge.
- f_{offset} is the separation between the sub-block edge frequency and the centre of the measuring filter.
- $f_{\text{offset}_{\text{max}}}$ is equal to the sub-block gap bandwidth minus half of the bandwidth of the measuring filter.
- Δf_{max} is equal to $f_{\text{offset}_{\text{max}}}$ minus half of the bandwidth of the measuring filter.

4.2.2.2.1 Limits for Wide Area BS (bands 1, 3, 8, 32, 33, 34 or 65)

For E-UTRA Wide Area BS operating in band 1, 3, 8, 33, 34 or 65, emissions shall not exceed the maximum levels specified in tables 4.2.2.2.1-1 to 4.2.2.2.1-3.

Table 4.2.2.2.1-1: Wide Area BS operating band unwanted emission limits for 1,4 MHz channel bandwidth (E-UTRA bands 1, 3, 8, 32, 33, 34 or 65)

Frequency offset of measurement filter -3 dB point, Δf	Frequency offset of measurement filter centre frequency, f_{offset}	Test requirement (notes 1 and 2)	Measurement bandwidth
$0 \text{ MHz} \leq \Delta f < 0,05 \text{ MHz}$	$0,015 \text{ MHz} \leq f_{\text{offset}} < 0,065 \text{ MHz}$	$6,5 \text{ dBm} - 60 \times \left(\frac{f_{\text{offset}}}{\text{MHz}} - 0,015 \right) \text{ dB}$	30 kHz
$0,05 \text{ MHz} \leq \Delta f < 0,15 \text{ MHz}$	$0,065 \text{ MHz} \leq f_{\text{offset}} < 0,165 \text{ MHz}$	$3,5 \text{ dBm} - 160 \times \left(\frac{f_{\text{offset}}}{\text{MHz}} - 0,065 \right) \text{ dB}$	30 kHz
$0,15 \text{ MHz} \leq \Delta f < 0,2 \text{ MHz}$	$0,165 \text{ MHz} \leq f_{\text{offset}} < 0,215 \text{ MHz}$	-12,5 dBm	30 kHz
$0,2 \text{ MHz} \leq \Delta f < 1 \text{ MHz}$	$0,215 \text{ MHz} \leq f_{\text{offset}} < 1,015 \text{ MHz}$	$-12,5 \text{ dBm} - 15 \times \left(\frac{f_{\text{offset}}}{\text{MHz}} - 0,215 \right) \text{ dB}$	30 kHz
	$1,015 \text{ MHz} \leq f_{\text{offset}} < 1,5 \text{ MHz}$	-24,5 dBm	30 kHz
$1 \text{ MHz} \leq \Delta f \leq 2,8 \text{ MHz}$	$1,5 \text{ MHz} \leq f_{\text{offset}} < 3,3 \text{ MHz}$	-11,5 dBm	1 MHz
$2,8 \text{ MHz} \leq \Delta f \leq \Delta f_{\text{max}}$	$3,3 \text{ MHz} \leq f_{\text{offset}} < f_{\text{offset}_{\text{max}}}$	-15 dBm	1 MHz
NOTE 1: For a BS supporting non-contiguous spectrum operation within any operating band the test requirement within sub-block gaps is calculated as a cumulative sum of contributions from adjacent sub-blocks on each side of the sub-block gap, where the contribution from the far-end sub-block shall be scaled according to the measurement bandwidth of the near-end sub-block. Exception is $\Delta f \geq 10 \text{ MHz}$ from both adjacent sub-blocks on each side of the sub-block gap, where the test requirement within sub-block gaps shall be -13 dBm/100 kHz.			
NOTE 2: For BS supporting multi-band operation with Inter RF Bandwidth gap < 20 MHz the test requirement within the Inter RF Bandwidth gaps is calculated as a cumulative sum of contributions from adjacent sub-blocks or Base Station RF Bandwidth on each side of the Inter RF Bandwidth gap, where the contribution from the far-end sub-block or Base Station RF Bandwidth shall be scaled according to the measurement bandwidth of the near-end sub-block or Base Station RF Bandwidth.			

Table 4.2.2.2.1-2: Wide Area BS operating band unwanted emission limits for 3 MHz channel bandwidth (E-UTRA bands 1, 3, 8, 32, 33, 34 or 65)

Frequency offset of measurement filter -3 dB point, Δf	Frequency offset of measurement filter centre frequency, f_{offset}	Test requirement (notes 1 and 2)	Measurement bandwidth
$0 \text{ MHz} \leq \Delta f < 0,05 \text{ MHz}$	$0,015 \text{ MHz} \leq f_{\text{offset}} < 0,065 \text{ MHz}$	$6,5 \text{ dBm} - 60 \times \left(\frac{f_{\text{offset}}}{\text{MHz}} - 0,015 \right) \text{ dB}$	30 kHz
$0,05 \text{ MHz} \leq \Delta f < 0,15 \text{ MHz}$	$0,065 \text{ MHz} \leq f_{\text{offset}} < 0,165 \text{ MHz}$	$3,5 \text{ dBm} - 160 \times \left(\frac{f_{\text{offset}}}{\text{MHz}} - 0,065 \right) \text{ dB}$	30 kHz
$0,15 \text{ MHz} \leq \Delta f < 0,2 \text{ MHz}$	$0,165 \text{ MHz} \leq f_{\text{offset}} < 0,215 \text{ MHz}$	-12,5 dBm	30 kHz
$0,2 \text{ MHz} \leq \Delta f < 1 \text{ MHz}$	$0,215 \text{ MHz} \leq f_{\text{offset}} < 1,015 \text{ MHz}$	$-12,5 \text{ dBm} - 15 \times \left(\frac{f_{\text{offset}}}{\text{MHz}} - 0,215 \right) \text{ dB}$	30 kHz
	$1,015 \text{ MHz} \leq f_{\text{offset}} < 1,5 \text{ MHz}$	-24,5 dBm	30 kHz
$1 \text{ MHz} \leq \Delta f \leq 6 \text{ MHz}$	$1,5 \text{ MHz} \leq f_{\text{offset}} < 6,5 \text{ MHz}$	-11,5 dBm	1 MHz
$6 \text{ MHz} \leq \Delta f \leq \Delta f_{\text{max}}$	$6,5 \text{ MHz} \leq f_{\text{offset}} < f_{\text{offset}_{\text{max}}}$	-15 dBm	1 MHz
NOTE 1: For a BS supporting non-contiguous spectrum operation within any operating band the test requirement within sub-block gaps is calculated as a cumulative sum of contributions from adjacent sub-blocks on each side of the sub-block gap, where the contribution from the far-end sub-block shall be scaled according to the measurement bandwidth of the near-end sub-block. Exception is $\Delta f \geq 10 \text{ MHz}$ from both adjacent sub-blocks on each side of the sub-block gap, where the test requirement within sub-block gaps shall be -13 dBm/100 kHz.			
NOTE 2: For BS supporting multi-band operation with Inter RF Bandwidth gap < 20 MHz the test requirement within the Inter RF Bandwidth gaps is calculated as a cumulative sum of contributions from adjacent sub-blocks or Base Station RF Bandwidth on each side of the Inter RF Bandwidth gap, where the contribution from the far-end sub-block or Base Station RF Bandwidth shall be scaled according to the measurement bandwidth of the near-end sub-block or Base Station RF Bandwidth.			

Table 4.2.2.2.1-3: Wide Area BS operating band unwanted emission limits for 5 MHz, 10 MHz, 15 MHz and 20 MHz channel bandwidth (E-UTRA bands 1, 3, 8, 32, 33, 34 or 65)

Frequency offset of measurement filter -3 dB point, Δf	Frequency offset of measurement filter centre frequency, f_{offset}	Test requirement (notes 1, 2 and 3)	Measurement bandwidth
$0 \text{ MHz} \leq \Delta f < 0,2 \text{ MHz}$	$0,015 \text{ MHz} \leq f_{\text{offset}} < 0,215 \text{ MHz}$	-12,5 dBm	30 kHz
$0,2 \text{ MHz} \leq \Delta f < 1 \text{ MHz}$	$0,215 \text{ MHz} \leq f_{\text{offset}} < 1,015 \text{ MHz}$	$-12,5 \text{ dBm} - 15 \times \left(\frac{f_{\text{offset}}}{\text{MHz}} - 0,215 \right) \text{ dB}$	30 kHz
	$1,015 \text{ MHz} \leq f_{\text{offset}} < 1,5 \text{ MHz}$	-24,5 dBm	30 kHz
$1 \text{ MHz} \leq \Delta f \leq \min(10 \text{ MHz}, \Delta f_{\text{max}})$	$1,5 \text{ MHz} \leq f_{\text{offset}} < \min(10,5 \text{ MHz}, f_{\text{offset}_{\text{max}}})$	-11,5 dBm	1 MHz
$10 \text{ MHz} \leq \Delta f \leq \Delta f_{\text{max}}$	$10,5 \text{ MHz} \leq f_{\text{offset}} < f_{\text{offset}_{\text{max}}}$	-15 dBm	1 MHz

NOTE 1: The requirement is not applicable when $\Delta f_{\text{max}} < 10 \text{ MHz}$.

NOTE 2: For a BS supporting non-contiguous spectrum operation within any operating band the test requirement within sub-block gaps is calculated as a cumulative sum of contributions from adjacent sub-blocks on each side of the sub-block gap, where the contribution from the far-end sub-block shall be scaled according to the measurement bandwidth of the near-end sub-block. Exception is $\Delta f \geq 10 \text{ MHz}$ from both adjacent sub-blocks on each side of the sub-block gap, where the test requirement within sub-block gaps shall be -13 dBm/100 kHz.

NOTE 3: For BS supporting multi-band operation with Inter RF Bandwidth gap < 20 MHz the test requirement within the Inter RF Bandwidth gaps is calculated as a cumulative sum of contributions from adjacent sub-blocks or Base Station RF Bandwidth on each side of the Inter RF Bandwidth gap, where the contribution from the far-end sub-block or Base Station RF Bandwidth shall be scaled according to the measurement bandwidth of the near-end sub-block or Base Station RF Bandwidth.

4.2.2.2.2 Limits for Wide Area BS (bands 7, 22, 38, 40, 42, 43 and 69)

For E-UTRA Wide Area BS operating in bands 7, 38, 40 and 69 emissions shall not exceed the maximum levels specified in tables 4.2.2.2.2-1, 4.2.2.2.2-2 and 4.2.2.2.2-3.

For E-UTRA Wide Area BS operating in bands 22, 42 and 43, emissions shall not exceed the maximum levels specified in tables 4.2.2.2.2-1A, 4.2.2.2.2-2A and 4.2.2.2.2-3A.

Table 4.2.2.2.2-1: Wide Area BS operating band unwanted emission limits for 1,4 MHz channel bandwidth (E-UTRA bands 7, 38, 40 and 69)

Frequency offset of measurement filter -3 dB point, Δf	Frequency offset of measurement filter centre frequency, f_{offset}	Test requirement (notes 1 and 2)	Measurement bandwidth
$0 \text{ MHz} \leq \Delta f < 1,4 \text{ MHz}$	$0,05 \text{ MHz} \leq f_{\text{offset}} < 1,45 \text{ MHz}$	$+0,5 \text{ dBm} - \frac{10}{1,4} \times \left(\frac{f_{\text{offset}}}{\text{MHz}} - 0,05 \right) \text{ dB}$	100 kHz
$1,4 \text{ MHz} \leq \Delta f < 2,8 \text{ MHz}$	$1,45 \text{ MHz} \leq f_{\text{offset}} < 2,85 \text{ MHz}$	-9,5 dBm	100 kHz
$2,8 \text{ MHz} \leq \Delta f \leq \Delta f_{\text{max}}$	$3,3 \text{ MHz} \leq f_{\text{offset}} < f_{\text{offset}_{\text{max}}}$	-15 dBm	1 MHz

NOTE 1: For a BS supporting non-contiguous spectrum operation within any operating band the test requirement within sub-block gaps is calculated as a cumulative sum of contributions from adjacent sub-blocks on each side of the sub-block gap, where the contribution from the far-end sub-block shall be scaled according to the measurement bandwidth of the near-end sub-block. Exception is $\Delta f \geq 10 \text{ MHz}$ from both adjacent sub-blocks on each side of the sub-block gap, where the test requirement within sub-block gaps shall be -13 dBm/100 kHz.

NOTE 2: For BS supporting multi-band operation with Inter RF Bandwidth gap < 20 MHz the test requirement within the Inter RF Bandwidth gaps is calculated as a cumulative sum of contributions from adjacent sub-blocks or Base Station RF Bandwidth on each side of the Inter RF Bandwidth gap, where the contribution from the far-end sub-block or Base Station RF Bandwidth shall be scaled according to the measurement bandwidth of the near-end sub-block or Base Station RF Bandwidth.

Table 4.2.2.2-1A: Wide Area BS operating band unwanted emission limits for 1,4 MHz channel bandwidth (E-UTRA bands 22, 42 and 43)

Frequency offset of measurement filter -3 dB point, Δf	Frequency offset of measurement filter centre frequency, f_{offset}	Test requirement (notes 1 and 2)	Measurement bandwidth
$0 \text{ MHz} \leq \Delta f < 1,4 \text{ MHz}$	$0,05 \text{ MHz} \leq f_{\text{offset}} < 1,45 \text{ MHz}$	$+ 0,8 \text{ dBm} - \frac{10}{1,4} \times \left(\frac{f_{\text{offset}}}{\text{MHz}} - 0,05 \right) \text{ dB}$	100 kHz
$1,4 \text{ MHz} \leq \Delta f < 2,8 \text{ MHz}$	$1,45 \text{ MHz} \leq f_{\text{offset}} < 2,85 \text{ MHz}$	-9,2 dBm	100 kHz
$2,8 \text{ MHz} \leq \Delta f \leq \Delta f_{\text{max}}$	$3,3 \text{ MHz} \leq f_{\text{offset}} < f_{\text{offset}_{\text{max}}}$	-15 dBm	1 MHz
NOTE 1: For a BS supporting non-contiguous spectrum operation within any operating band the test requirement within sub-block gaps is calculated as a cumulative sum of contributions from adjacent sub-blocks on each side of the sub-block gap, where the contribution from the far-end sub-block shall be scaled according to the measurement bandwidth of the near-end sub-block. Exception is $\Delta f \geq 10 \text{ MHz}$ from both adjacent sub-blocks on each side of the sub-block gap, where the test requirement within sub-block gaps shall be -13 dBm/100 kHz.			
NOTE 2: For BS supporting multi-band operation with Inter RF Bandwidth gap < 20 MHz the test requirement within the Inter RF Bandwidth gaps is calculated as a cumulative sum of contributions from adjacent sub-blocks or Base Station RF Bandwidth on each side of the Inter RF Bandwidth gap, where the contribution from the far-end sub-block or Base Station RF Bandwidth shall be scaled according to the measurement bandwidth of the near-end sub-block or Base Station RF Bandwidth.			

Table 4.2.2.2-2: Wide Area BS operating band unwanted emission limits for 3 MHz channel bandwidth (E-UTRA bands 7, 38, 40 and 69)

Frequency offset of measurement filter -3 dB point, Δf	Frequency offset of measurement filter centre frequency, f_{offset}	Test requirement (notes 1 and 2)	Measurement bandwidth
$0 \text{ MHz} \leq \Delta f < 3 \text{ MHz}$	$0,05 \text{ MHz} \leq f_{\text{offset}} < 3,05 \text{ MHz}$	$- 3,5 \text{ dBm} - \frac{10}{3} \times \left(\frac{f_{\text{offset}}}{\text{MHz}} - 0,05 \right) \text{ dB}$	100 kHz
$3 \text{ MHz} \leq \Delta f < 6 \text{ MHz}$	$3,05 \text{ MHz} \leq f_{\text{offset}} < 6,05 \text{ MHz}$	-13,5 dBm	100 kHz
$6 \text{ MHz} \leq \Delta f \leq \Delta f_{\text{max}}$	$6,5 \text{ MHz} \leq f_{\text{offset}} < f_{\text{offset}_{\text{max}}}$	-15 dBm	1 MHz
NOTE 1: For a BS supporting non-contiguous spectrum operation within any operating band the test requirement within sub-block gaps is calculated as a cumulative sum of contributions from adjacent sub-blocks on each side of the sub-block gap, where the contribution from the far-end sub-block shall be scaled according to the measurement bandwidth of the near-end sub-block. Exception is $\Delta f \geq 10 \text{ MHz}$ from both adjacent sub-blocks on each side of the sub-block gap, where the test requirement within sub-block gaps shall be -13 dBm/100 kHz.			
NOTE 2: For BS supporting multi-band operation with Inter RF Bandwidth gap < 20 MHz the test requirement within the Inter RF Bandwidth gaps is calculated as a cumulative sum of contributions from adjacent sub-blocks or Base Station RF Bandwidth on each side of the Inter RF Bandwidth gap, where the contribution from the far-end sub-block or Base Station RF Bandwidth shall be scaled according to the measurement bandwidth of the near-end sub-block or Base Station RF Bandwidth.			

Table 4.2.2.2-2A: Wide Area BS operating band unwanted emission limits for 3 MHz channel bandwidth (E-UTRA bands 22, 42 and 43)

Frequency offset of measurement filter -3 dB point, Δf	Frequency offset of measurement filter centre frequency, f_{offset}	Test requirement (notes 1 and 2)	Measurement bandwidth
$0 \text{ MHz} \leq \Delta f < 3 \text{ MHz}$	$0,05 \text{ MHz} \leq f_{\text{offset}} < 3,05 \text{ MHz}$	$- 3,2 \text{ dBm} - \frac{10}{3} \times \left(\frac{f_{\text{offset}}}{\text{MHz}} - 0,05 \right) \text{ dB}$	100 kHz
$3 \text{ MHz} \leq \Delta f < 6 \text{ MHz}$	$3,05 \text{ MHz} \leq f_{\text{offset}} < 6,05 \text{ MHz}$	-13,2 dBm	100 kHz
$6 \text{ MHz} \leq \Delta f \leq \Delta f_{\text{max}}$	$6,5 \text{ MHz} \leq f_{\text{offset}} < f_{\text{offset}_{\text{max}}}$	-15 dBm	1 MHz
NOTE 1: For a BS supporting non-contiguous spectrum operation within any operating band the test requirement within sub-block gaps is calculated as a cumulative sum of contributions from adjacent sub-blocks on each side of the sub-block gap, where the contribution from the far-end sub-block shall be scaled according to the measurement bandwidth of the near-end sub-block. Exception is $\Delta f \geq 10 \text{ MHz}$ from both adjacent sub-blocks on each side of the sub-block gap, where the test requirement within sub-block gaps shall be -13 dBm/100 kHz.			
NOTE 2: For BS supporting multi-band operation with Inter RF Bandwidth gap < 20 MHz the test requirement within the Inter RF Bandwidth gaps is calculated as a cumulative sum of contributions from adjacent sub-blocks or Base Station RF Bandwidth on each side of the Inter RF Bandwidth gap, where the contribution from the far-end sub-block or Base Station RF Bandwidth shall be scaled according to the measurement bandwidth of the near-end sub-block or Base Station RF Bandwidth.			

Table 4.2.2.2-3: Wide Area BS operating band unwanted emission limits for 5 MHz, 10 MHz, 15 MHz and 20 MHz channel bandwidth (E-UTRA bands 7, 38, 40 and 69)

Frequency offset of measurement filter -3 dB point, Δf	Frequency offset of measurement filter centre frequency, f_{offset}	Test requirement (notes 1, 2 and 3)	Measurement bandwidth
$0 \text{ MHz} \leq \Delta f < 5 \text{ MHz}$	$0,05 \text{ MHz} \leq f_{\text{offset}} < 5,05 \text{ MHz}$	$-5,5 \text{ dBm} - \frac{7}{5} \times \left(\frac{f_{\text{offset}}}{\text{MHz}} - 0,05 \right) \text{ dB}$	100 kHz
$5 \text{ MHz} \leq \Delta f < \min(10 \text{ MHz}, \Delta f_{\text{max}})$	$5,05 \text{ MHz} \leq f_{\text{offset}} < \min(10,05 \text{ MHz}, f_{\text{offset}_{\text{max}}})$	-12,5 dBm	100 kHz
$10 \text{ MHz} \leq \Delta f \leq \Delta f_{\text{max}}$	$10,5 \text{ MHz} \leq f_{\text{offset}} < f_{\text{offset}_{\text{max}}}$	-15 dBm	1 MHz

NOTE 1: The requirement is not applicable when $\Delta f_{\text{max}} < 10 \text{ MHz}$.

NOTE 2: For a BS supporting non-contiguous spectrum operation within any operating band the test requirement within sub-block gaps is calculated as a cumulative sum of contributions from adjacent sub-blocks on each side of the sub-block gap, where the contribution from the far-end sub-block shall be scaled according to the measurement bandwidth of the near-end sub-block. Exception is $\Delta f \geq 10 \text{ MHz}$ from both adjacent sub-blocks on each side of the sub-block gap, where the test requirement within sub-block gaps shall be -13 dBm/100 kHz.

NOTE 3: For BS supporting multi-band operation with Inter RF Bandwidth gap < 20 MHz the test requirement within the Inter RF Bandwidth gaps is calculated as a cumulative sum of contributions from adjacent sub-blocks or Base Station RF Bandwidth on each side of the Inter RF Bandwidth gap, where the contribution from the far-end sub-block or Base Station RF Bandwidth shall be scaled according to the measurement bandwidth of the near-end sub-block or Base Station RF Bandwidth.

Table 4.2.2.2-3A: Wide Area BS operating band unwanted emission limits for 5 MHz, 10 MHz, 15 MHz and 20 MHz channel bandwidth (E-UTRA bands 22, 42 and 43)

Frequency offset of measurement filter -3 dB point, Δf	Frequency offset of measurement filter centre frequency, f_{offset}	Test requirement (notes 1, 2 and 3)	Measurement bandwidth
$0 \text{ MHz} \leq \Delta f < 5 \text{ MHz}$	$0,05 \text{ MHz} \leq f_{\text{offset}} < 5,05 \text{ MHz}$	$-5,2 \text{ dBm} - \frac{7}{5} \times \left(\frac{f_{\text{offset}}}{\text{MHz}} - 0,05 \right) \text{ dB}$	100 kHz
$5 \text{ MHz} \leq \Delta f < \min(10 \text{ MHz}, \Delta f_{\text{max}})$	$5,05 \text{ MHz} \leq f_{\text{offset}} < \min(10,05 \text{ MHz}, f_{\text{offset}_{\text{max}}})$	-12,2 dBm	100 kHz
$10 \text{ MHz} \leq \Delta f \leq \Delta f_{\text{max}}$	$10,5 \text{ MHz} \leq f_{\text{offset}} < f_{\text{offset}_{\text{max}}}$	-15 dBm	1 MHz

NOTE 1: The requirement is not applicable when $\Delta f_{\text{max}} < 10 \text{ MHz}$.

NOTE 2: For a BS supporting non-contiguous spectrum operation within any operating band the test requirement within sub-block gaps is calculated as a cumulative sum of contributions from adjacent sub-blocks on each side of the sub-block gap, where the contribution from the far-end sub-block shall be scaled according to the measurement bandwidth of the near-end sub-block. Exception is $\Delta f \geq 10 \text{ MHz}$ from both adjacent sub-blocks on each side of the sub-block gap, where the test requirement within sub-block gaps shall be -13 dBm/100 kHz.

NOTE 3: For BS supporting multi-band operation with Inter RF Bandwidth gap < 20 MHz the test requirement within the Inter RF Bandwidth gaps is calculated as a cumulative sum of contributions from adjacent sub-blocks or Base Station RF Bandwidth on each side of the Inter RF Bandwidth gap, where the contribution from the far-end sub-block or Base Station RF Bandwidth shall be scaled according to the measurement bandwidth of the near-end sub-block or Base Station RF Bandwidth.

4.2.2.2.3 Limits for Wide Area BS (bands 20, 28, 31, 67 and 68)

For E-UTRA Wide Area BS operating in band 20, 28, 31, 67 and 68 emissions shall not exceed the maximum levels specified in tables 4.2.2.2.3-1 to 4.2.2.2.3-3.

Table 4.2.2.2.3-1: Wide Area BS operating band unwanted emission limits for 1,4 MHz channel bandwidth (E-UTRA band 20, 28, 31, 67 and 68)

Frequency offset of measurement filter -3 dB point, Δf	Frequency offset of measurement filter centre frequency, f_{offset}	Test requirement (notes 1 and 2)	Measurement bandwidth
$0 \text{ MHz} \leq \Delta f < 1,4 \text{ MHz}$	$0,05 \text{ MHz} \leq f_{\text{offset}} < 1,45 \text{ MHz}$	$+ 0,5 \text{ dBm} - \frac{10}{1,4} \times \left(\frac{f_{\text{offset}}}{\text{MHz}} - 0,05 \right) \text{ dB}$	100 kHz
$1,4 \text{ MHz} \leq \Delta f < 2,8 \text{ MHz}$	$1,45 \text{ MHz} \leq f_{\text{offset}} < 2,85 \text{ MHz}$	-9,5 dBm	100 kHz
$2,8 \text{ MHz} \leq \Delta f \leq \Delta f_{\text{max}}$	$2,85 \text{ MHz} \leq f_{\text{offset}} < f_{\text{offset}_{\text{max}}}$	-16 dBm	100 kHz

NOTE 1: For a BS supporting non-contiguous spectrum operation within any operating band the test requirement within sub-block gaps is calculated as a cumulative sum of contributions from adjacent sub-blocks on each side of the sub-block gap. Exception is $\Delta f \geq 10 \text{ MHz}$ from both adjacent sub-blocks on each side of the sub-block gap, where the test requirement within sub-block gaps shall be -13 dBm/100 kHz.

NOTE 2: For BS supporting multi-band operation with Inter RF Bandwidth gap < 20 MHz the test requirement within the Inter RF Bandwidth gaps is calculated as a cumulative sum of contributions from adjacent sub-blocks or Base Station RF Bandwidth on each side of the Inter RF Bandwidth gap.

Table 4.2.2.2.3-2: Wide Area BS operating band unwanted emission limits for 3 MHz channel bandwidth (E-UTRA band 20, 28, 31, 67 and 68)

Frequency offset of measurement filter -3 dB point, Δf	Frequency offset of measurement filter centre frequency, f_{offset}	Test requirement (notes 1 and 2)	Measurement bandwidth
$0 \text{ MHz} \leq \Delta f < 3 \text{ MHz}$	$0,05 \text{ MHz} \leq f_{\text{offset}} < 3,05 \text{ MHz}$	$- 3,5 \text{ dBm} - \frac{10}{3} \times \left(\frac{f_{\text{offset}}}{\text{MHz}} - 0,05 \right) \text{ dB}$	100 kHz
$3 \text{ MHz} \leq \Delta f < 6 \text{ MHz}$	$3,05 \text{ MHz} \leq f_{\text{offset}} < 6,05 \text{ MHz}$	-13,5 dBm	100 kHz
$6 \text{ MHz} \leq \Delta f \leq \Delta f_{\text{max}}$	$6,05 \text{ MHz} \leq f_{\text{offset}} < f_{\text{offset}_{\text{max}}}$	-16 dBm	100 kHz

NOTE 1: For a BS supporting non-contiguous spectrum operation within any operating band the test requirement within sub-block gaps is calculated as a cumulative sum of contributions from adjacent sub-blocks on each side of the sub-block gap. Exception is $\Delta f \geq 10 \text{ MHz}$ from both adjacent sub-blocks on each side of the sub-block gap, where the test requirement within sub-block gaps shall be -13 dBm/100 kHz.

NOTE 2: For BS supporting multi-band operation with Inter RF Bandwidth gap < 20 MHz the test requirement within the Inter RF Bandwidth gaps is calculated as a cumulative sum of contributions from adjacent sub-blocks or Base Station RF Bandwidth on each side of the Inter RF Bandwidth gap.

Table 4.2.2.2.3-3: Wide Area BS operating band unwanted emission limits for 5 MHz, 10 MHz, 15 MHz and 20 MHz channel bandwidth (E-UTRA band 20, 28, 31, 67 and 68)

Frequency offset of measurement filter -3 dB point, Δf	Frequency offset of measurement filter centre frequency, f_{offset}	Test requirement (notes 1, 2 and 3)	Measurement bandwidth
$0 \text{ MHz} \leq \Delta f < 5 \text{ MHz}$	$0,05 \text{ MHz} \leq f_{\text{offset}} < 5,05 \text{ MHz}$	$- 5,5 \text{ dBm} - \frac{7}{5} \times \left(\frac{f_{\text{offset}}}{\text{MHz}} - 0,05 \right) \text{ dB}$	100 kHz
$5 \text{ MHz} \leq \Delta f < 10 \text{ MHz}$	$5,05 \text{ MHz} \leq f_{\text{offset}} < 10,05 \text{ MHz}$	-12,5 dBm	100 kHz
$10 \text{ MHz} \leq \Delta f \leq \Delta f_{\text{max}}$	$10,05 \text{ MHz} \leq f_{\text{offset}} < f_{\text{offset}_{\text{max}}}$	-16 dBm	100 kHz

NOTE 1: The requirement is not applicable when $\Delta f_{\text{max}} < 10 \text{ MHz}$.

NOTE 2: For a BS supporting non-contiguous spectrum operation within any operating band the test requirement within sub-block gaps is calculated as a cumulative sum of contributions from adjacent sub-blocks on each side of the sub-block gap, where the contribution from the far-end sub-block shall be scaled according to the measurement bandwidth of the near-end sub-block. Exception is $\Delta f \geq 10 \text{ MHz}$ from both adjacent sub-blocks on each side of the sub-block gap, where the test requirement within sub-block gaps shall be -13 dBm/100 kHz.

NOTE 3: For BS supporting multi-band operation with Inter RF Bandwidth gap < 20 MHz the test requirement within the Inter RF Bandwidth gaps is calculated as a cumulative sum of contributions from adjacent sub-blocks or Base Station RF Bandwidth on each side of the Inter RF Bandwidth gap.

4.2.2.2.4 Limits for Local Area BS

For Local Area BS, in E-UTRA bands ≤ 3 GHz, emissions shall not exceed the maximum levels specified in tables 4.2.2.2.4-1, 4.2.2.2.4-2 and 4.2.2.2.4-3.

For Local Area BS in E-UTRA bands > 3 GHz, emissions shall not exceed the maximum levels specified in tables 4.2.2.2.4-1A, 4.2.2.2.4-2A and 4.2.2.2.4-3A.

Table 4.2.2.2.4-1: Local Area BS operating band unwanted emission limits for 1,4 MHz channel bandwidth (E-UTRA bands ≤ 3 GHz)

Frequency offset of measurement filter -3 dB point, Δf	Frequency offset of measurement filter centre frequency, f_{offset}	Test requirement	Measurement bandwidth
$0 \text{ MHz} \leq \Delta f < 1,4 \text{ MHz}$	$0,05 \text{ MHz} \leq f_{\text{offset}} < 1,45 \text{ MHz}$	$-19,5 \text{ dBm} - \frac{10}{1,4} \times \left(\frac{f_{\text{offset}}}{\text{MHz}} - 0,05 \right) \text{ dB}$	100 kHz
$1,4 \text{ MHz} \leq \Delta f < 2,8 \text{ MHz}$	$1,45 \text{ MHz} \leq f_{\text{offset}} < 2,85 \text{ MHz}$	-29,5 dBm	100 kHz
$2,8 \text{ MHz} \leq \Delta f \leq \Delta f_{\text{max}}$	$2,85 \text{ MHz} \leq f_{\text{offset}} < f_{\text{offset}_{\text{max}}}$	-31 dBm	100 kHz

Table 4.2.2.2.4-1A: Local Area BS operating band unwanted emission limits for 1,4 MHz channel bandwidth (E-UTRA bands > 3 GHz)

Frequency offset of measurement filter -3 dB point, Δf	Frequency offset of measurement filter centre frequency, f_{offset}	Test requirement	Measurement bandwidth
$0 \text{ MHz} \leq \Delta f < 1,4 \text{ MHz}$	$0,05 \text{ MHz} \leq f_{\text{offset}} < 1,45 \text{ MHz}$	$-19,2 \text{ dBm} - \frac{10}{1,4} \times \left(\frac{f_{\text{offset}}}{\text{MHz}} - 0,05 \right) \text{ dB}$	100 kHz
$1,4 \text{ MHz} \leq \Delta f < 2,8 \text{ MHz}$	$1,45 \text{ MHz} \leq f_{\text{offset}} < 2,85 \text{ MHz}$	-29,2 dBm	100 kHz
$2,8 \text{ MHz} \leq \Delta f \leq \Delta f_{\text{max}}$	$2,85 \text{ MHz} \leq f_{\text{offset}} < f_{\text{offset}_{\text{max}}}$	-31 dBm	100 kHz

Table 4.2.2.2.4-2: Local Area BS operating band unwanted emission limits for 3 MHz channel bandwidth (E-UTRA bands ≤ 3 GHz)

Frequency offset of measurement filter -3 dB point, Δf	Frequency offset of measurement filter centre frequency, f_{offset}	Test requirement	Measurement bandwidth
$0 \text{ MHz} \leq \Delta f < 3 \text{ MHz}$	$0,05 \text{ MHz} \leq f_{\text{offset}} < 3,05 \text{ MHz}$	$-23,5 \text{ dBm} - \frac{10}{3} \times \left(\frac{f_{\text{offset}}}{\text{MHz}} - 0,05 \right) \text{ dB}$	100 kHz
$3 \text{ MHz} \leq \Delta f < 6 \text{ MHz}$	$3,05 \text{ MHz} \leq f_{\text{offset}} < 6,05 \text{ MHz}$	-33,5 dBm	100 kHz
$6 \text{ MHz} \leq \Delta f \leq \Delta f_{\text{max}}$	$6,05 \text{ MHz} \leq f_{\text{offset}} < f_{\text{offset}_{\text{max}}}$	-35 dBm	100 kHz

Table 4.2.2.2.4-2A: Local Area BS operating band unwanted emission limits for 3 MHz channel bandwidth (E-UTRA bands > 3 GHz)

Frequency offset of measurement filter -3 dB point, Δf	Frequency offset of measurement filter centre frequency, f_{offset}	Test requirement	Measurement bandwidth
$0 \text{ MHz} \leq \Delta f < 3 \text{ MHz}$	$0,05 \text{ MHz} \leq f_{\text{offset}} < 3,05 \text{ MHz}$	$-23,2 \text{ dBm} - \frac{10}{3} \times \left(\frac{f_{\text{offset}}}{\text{MHz}} - 0,05 \right) \text{ dB}$	100 kHz
$3 \text{ MHz} \leq \Delta f < 6 \text{ MHz}$	$3,05 \text{ MHz} \leq f_{\text{offset}} < 6,05 \text{ MHz}$	-33,2 dBm	100 kHz
$6 \text{ MHz} \leq \Delta f \leq \Delta f_{\text{max}}$	$6,05 \text{ MHz} \leq f_{\text{offset}} < f_{\text{offset}_{\text{max}}}$	-35 dBm	100 kHz

Table 4.2.2.4-3: Local Area BS operating band unwanted emission limits for 5 MHz, 10 MHz, 15 MHz and 20 MHz channel bandwidth (E-UTRA bands ≤ 3 GHz)

Frequency offset of measurement filter -3 dB point, Δf	Frequency offset of measurement filter centre frequency, f_{offset}	Test requirement	Measurement bandwidth
$0 \text{ MHz} \leq \Delta f < 5 \text{ MHz}$	$0,05 \text{ MHz} \leq f_{\text{offset}} < 5,05 \text{ MHz}$	$-28,5 \text{ dBm} - \frac{7}{5} \times \left(\frac{f_{\text{offset}}}{\text{MHz}} - 0,05 \right) \text{ dB}$	100 kHz
$5 \text{ MHz} \leq \Delta f < \min(10 \text{ MHz}, \Delta f_{\text{max}})$	$5,05 \text{ MHz} \leq f_{\text{offset}} < \min(10,05 \text{ MHz}, f_{\text{offset}_{\text{max}}})$	-35,5 dBm	100 kHz
$10 \text{ MHz} \leq \Delta f \leq \Delta f_{\text{max}}$	$10,05 \text{ MHz} \leq f_{\text{offset}} < f_{\text{offset}_{\text{max}}}$	-37 dBm (note)	100 kHz

NOTE: The requirement is not applicable when $\Delta f_{\text{max}} < 10 \text{ MHz}$.

Table 4.2.2.4-3A: Local Area BS operating band unwanted emission limits for 5 MHz, 10 MHz, 15 MHz and 20 MHz channel bandwidth (E-UTRA bands > 3 GHz)

Frequency offset of measurement filter -3 dB point, Δf	Frequency offset of measurement filter centre frequency, f_{offset}	Test requirement	Measurement bandwidth
$0 \text{ MHz} \leq \Delta f < 5 \text{ MHz}$	$0,05 \text{ MHz} \leq f_{\text{offset}} < 5,05 \text{ MHz}$	$-28,2 \text{ dBm} - \frac{7}{5} \times \left(\frac{f_{\text{offset}}}{\text{MHz}} - 0,05 \right) \text{ dB}$	100 kHz
$5 \text{ MHz} \leq \Delta f < \min(10 \text{ MHz}, \Delta f_{\text{max}})$	$5,05 \text{ MHz} \leq f_{\text{offset}} < \min(10,05 \text{ MHz}, f_{\text{offset}_{\text{max}}})$	-35,2 dBm	100 kHz
$10 \text{ MHz} \leq \Delta f \leq \Delta f_{\text{max}}$	$10,05 \text{ MHz} \leq f_{\text{offset}} < f_{\text{offset}_{\text{max}}}$	-37 dBm (note)	100 kHz

NOTE: The requirement is not applicable when $\Delta f_{\text{max}} < 10 \text{ MHz}$.

4.2.2.2.5 Limits for Home BS

For E-UTRA Home BS, in E-UTRA bands ≤ 3 GHz, emissions shall not exceed the maximum levels specified in tables 4.2.2.2.5-1, 4.2.2.2.5-2 and 4.2.2.2.5-3.

For E-UTRA Home BS, in E-UTRA bands > 3 GHz, emissions shall not exceed the maximum levels specified in tables 4.2.2.2.5-1A, 4.2.2.2.5-2A and 4.2.2.2.5-3A.

Table 4.2.2.2.5-1: Home BS operating band unwanted emission limits for 1,4 MHz channel bandwidth (E-UTRA bands ≤ 3 GHz)

Frequency offset of measurement filter -3 dB point, Δf	Frequency offset of measurement filter centre frequency, f_{offset}	Test requirement	Measurement bandwidth
$0 \text{ MHz} \leq \Delta f < 1,4 \text{ MHz}$	$0,05 \text{ MHz} \leq f_{\text{offset}} < 1,45 \text{ MHz}$	$-28,5 \text{ dBm} - \frac{6}{1,4} \times \left(\frac{f_{\text{offset}}}{\text{MHz}} - 0,05 \right) \text{ dB}$	100 kHz
$1,4 \text{ MHz} \leq \Delta f < 2,8 \text{ MHz}$	$1,45 \text{ MHz} \leq f_{\text{offset}} < 2,85 \text{ MHz}$	-34,5 dBm	100 kHz
$2,8 \text{ MHz} \leq \Delta f \leq \Delta f_{\text{max}}$	$3,3 \text{ MHz} \leq f_{\text{offset}} < f_{\text{offset}_{\text{max}}}$	$P - 52 \text{ dB}, 2 \text{ dBm} \leq P \leq 20 \text{ dBm}$ -50 dBm, $P < 2 \text{ dBm}$ (note)	1 MHz

NOTE: For Home BS, the parameter P is defined as the aggregated maximum power of all transmit antenna ports of Home BS.

Table 4.2.2.5-1A: Home BS operating band unwanted emission limits for 1,4 MHz channel bandwidth (E-UTRA bands > 3 GHz)

Frequency offset of measurement filter -3 dB point, Δf	Frequency offset of measurement filter centre frequency, f_{offset}	Test requirement	Measurement bandwidth
$0 \text{ MHz} \leq \Delta f < 1,4 \text{ MHz}$	$0,05 \text{ MHz} \leq f_{\text{offset}} < 1,45 \text{ MHz}$	$-28,2 \text{ dBm} - \frac{6}{1,4} \times \left(\frac{f_{\text{offset}}}{\text{MHz}} - 0,05 \right) \text{ dB}$	100 kHz
$1,4 \text{ MHz} \leq \Delta f < 2,8 \text{ MHz}$	$1,45 \text{ MHz} \leq f_{\text{offset}} < 2,85 \text{ MHz}$	-34,2 dBm	100 kHz
$2,8 \text{ MHz} \leq \Delta f \leq \Delta f_{\text{max}}$	$3,3 \text{ MHz} \leq f_{\text{offset}} < f_{\text{offset}_{\text{max}}}$	$P - 52 \text{ dB}$, $2 \text{ dBm} \leq P \leq 20 \text{ dBm}$ -50 dBm, $P < 2 \text{ dBm}$ (note)	1 MHz
NOTE: For Home BS, the parameter P is defined as the aggregated maximum power of all transmit antenna ports of Home BS.			

Table 4.2.2.5-2: Home BS operating band unwanted emission limits for 3 MHz channel bandwidth (E-UTRA bands \leq 3 GHz)

Frequency offset of measurement filter -3 dB point, Δf	Frequency offset of measurement filter centre frequency, f_{offset}	Test requirement	Measurement bandwidth
$0 \text{ MHz} \leq \Delta f < 3 \text{ MHz}$	$0,05 \text{ MHz} \leq f_{\text{offset}} < 3,05 \text{ MHz}$	$-32,5 \text{ dBm} - 2 \left(\frac{f_{\text{offset}}}{\text{MHz}} - 0,05 \right) \text{ dB}$	100 kHz
$3 \text{ MHz} \leq \Delta f < 6 \text{ MHz}$	$3,05 \text{ MHz} \leq f_{\text{offset}} < 6,05 \text{ MHz}$	-38,5 dBm	100 kHz
$6 \text{ MHz} \leq \Delta f \leq \Delta f_{\text{max}}$	$6,5 \text{ MHz} \leq f_{\text{offset}} < f_{\text{offset}_{\text{max}}}$	$P - 52 \text{ dB}$, $2 \text{ dBm} \leq P \leq 20 \text{ dBm}$ -50 dBm, $P < 2 \text{ dBm}$ (note)	1 MHz
NOTE: For Home BS, the parameter P is defined as the aggregated maximum power of all transmit antenna ports of Home BS.			

Table 4.2.2.5-2A: Home BS operating band unwanted emission limits for 3 MHz channel bandwidth (E-UTRA bands > 3 GHz)

Frequency offset of measurement filter -3 dB point, Δf	Frequency offset of measurement filter centre frequency, f_{offset}	Test requirement	Measurement bandwidth
$0 \text{ MHz} \leq \Delta f < 3 \text{ MHz}$	$0,05 \text{ MHz} \leq f_{\text{offset}} < 3,05 \text{ MHz}$	$-32,2 \text{ dBm} - 2 \left(\frac{f_{\text{offset}}}{\text{MHz}} - 0,05 \right) \text{ dB}$	100 kHz
$3 \text{ MHz} \leq \Delta f < 6 \text{ MHz}$	$3,05 \text{ MHz} \leq f_{\text{offset}} < 6,05 \text{ MHz}$	-38,2 dBm	100 kHz
$6 \text{ MHz} \leq \Delta f \leq \Delta f_{\text{max}}$	$6,5 \text{ MHz} \leq f_{\text{offset}} < f_{\text{offset}_{\text{max}}}$	$P - 52 \text{ dB}$, $2 \text{ dBm} \leq P \leq 20 \text{ dBm}$ -50 dBm, $P < 2 \text{ dBm}$ (note)	1 MHz
NOTE: For Home BS, the parameter P is defined as the aggregated maximum power of all transmit antenna ports of Home BS.			

Table 4.2.2.5-3: Home BS operating band unwanted emission limits for 5 MHz, 10 MHz, 15 MHz and 20 MHz channel bandwidth (E-UTRA bands ≤ 3 GHz)

Frequency offset of measurement filter -3 dB point, Δf	Frequency offset of measurement filter centre frequency, f_{offset}	Test requirement	Measurement bandwidth
$0 \text{ MHz} \leq \Delta f < 5 \text{ MHz}$	$0,05 \text{ MHz} \leq f_{\text{offset}} < 5,05 \text{ MHz}$	$-34,5 \text{ dBm} - \frac{6}{5} \times \left(\frac{f_{\text{offset}}}{\text{MHz}} - 0,05 \right) \text{ dB}$	100 kHz
$5 \text{ MHz} \leq \Delta f < \min(10 \text{ MHz}, \Delta f_{\text{max}})$	$5,05 \text{ MHz} \leq f_{\text{offset}} < \min(10,05 \text{ MHz}, f_{\text{offset}_{\text{max}}})$	-40,5 dBm	100 kHz
$10 \text{ MHz} \leq \Delta f \leq \Delta f_{\text{max}}$	$10,5 \text{ MHz} \leq f_{\text{offset}} < f_{\text{offset}_{\text{max}}}$	$P - 52 \text{ dB}, 2 \text{ dBm} \leq P \leq 20 \text{ dBm}$ -50 dBm, $P < 2 \text{ dBm}$ (notes 1 and 2)	1 MHz

NOTE 1: For Home BS, the parameter P is defined as the aggregated maximum power of all transmit antenna ports of Home BS.
NOTE 2: The requirement is not applicable when $\Delta f_{\text{max}} < 10 \text{ MHz}$.

Table 4.2.2.5-3A: Home BS operating band unwanted emission limits for 5 MHz, 10 MHz, 15 MHz and 20 MHz channel bandwidth (E-UTRA bands > 3 GHz)

Frequency offset of measurement filter -3 dB point, Δf	Frequency offset of measurement filter centre frequency, f_{offset}	Test requirement	Measurement bandwidth
$0 \text{ MHz} \leq \Delta f < 5 \text{ MHz}$	$0,05 \text{ MHz} \leq f_{\text{offset}} < 5,05 \text{ MHz}$	$-34,2 \text{ dBm} - \frac{6}{5} \times \left(\frac{f_{\text{offset}}}{\text{MHz}} - 0,05 \right) \text{ dB}$	100 kHz
$5 \text{ MHz} \leq \Delta f < \min(10 \text{ MHz}, \Delta f_{\text{max}})$	$5,05 \text{ MHz} \leq f_{\text{offset}} < \min(10,05 \text{ MHz}, f_{\text{offset}_{\text{max}}})$	-40,2 dBm	100 kHz
$10 \text{ MHz} \leq \Delta f \leq \Delta f_{\text{max}}$	$10,5 \text{ MHz} \leq f_{\text{offset}} < f_{\text{offset}_{\text{max}}}$	$P - 52 \text{ dB}, 2 \text{ dBm} \leq P \leq 20 \text{ dBm}$ -50 dBm, $P < 2 \text{ dBm}$ (notes 1 and 2)	1 MHz

NOTE 1: For Home BS, the parameter P is defined as the aggregated maximum power of all transmit antenna ports of Home BS.
NOTE 2: The requirement is not applicable when $\Delta f_{\text{max}} < 10 \text{ MHz}$.

4.2.2.2.6 Additional limits for protection of DTT

For a BS operating in band 20, additional limits for protection of DTT are described in clause 6.6.3.5.3 of ETSI TS 136 141 [1]. This statement is provided for information and does not have any impact on the conformance requirements or essential radio test suites in the present document.

4.2.2.2.7 Limits for protection of adjacent band services

The following requirement shall apply for the protection of systems operating in frequency bands adjacent to band 1. The power of any spurious emission shall not exceed the limits specified in table 4.2.2.2.7-1.

Table 4.2.2.2.7-1: Emissions limits for protection of adjacent band services

Operating Band	Frequency range	Maximum Level	Measurement Bandwidth
1	2 100 MHz to 2 105 MHz	$-30 + 3,4 \times (f - 2 100 \text{ MHz}) \text{ dBm}$	1 MHz
	2 175 MHz to 2 180 MHz	$-30 + 3,4 \times (2 180 \text{ MHz} - f) \text{ dBm}$	1 MHz

4.2.2.2.8 Limits for Medium Range BS

For E-UTRA Medium Range BS, emissions shall not exceed the maximum levels specified in tables 4.2.2.2.8-1 to 4.2.2.2.8-12.

Table 4.2.2.8-1: Medium Range BS operating band unwanted emission limits for 1,4 MHz channel bandwidth, $31 < P_{\max,c} \leq 38$ dBm (E-UTRA bands ≤ 3 GHz)

Frequency offset of measurement filter -3 dB point, Δf	Frequency offset of measurement filter centre frequency, f_{offset}	Test requirement (notes 1 and 2)	Measurement bandwidth
$0 \text{ MHz} \leq \Delta f < 1,4 \text{ MHz}$	$0,05 \text{ MHz} \leq f_{\text{offset}} < 1,45 \text{ MHz}$	$P_{\max,c} - 43,5 \text{ dB} - \frac{10}{1,4} \times \left(\frac{f_{\text{offset}}}{\text{MHz}} - 0,05 \right) \text{ dB}$	100 kHz
$1,4 \text{ MHz} \leq \Delta f < 2,8 \text{ MHz}$	$1,45 \text{ MHz} \leq f_{\text{offset}} < 2,85 \text{ MHz}$	$P_{\max,c} - 53,5 \text{ dB}$	100 kHz
$2,8 \text{ MHz} \leq \Delta f \leq \Delta f_{\max}$	$2,85 \text{ MHz} \leq f_{\text{offset}} < f_{\text{offset}_{\max}}$	-25 dBm	100 kHz

NOTE 1: For a BS supporting non-contiguous spectrum operation within any operating band the test requirement within sub-block gaps is calculated as a cumulative sum contributions from of adjacent sub-blocks on each side of the sub-block gap. Exception is $\Delta f \geq 10$ MHz from both adjacent sub-blocks on each side of the sub-block gap, where the test requirement within sub-block gaps shall be -25 dBm/100 kHz.

NOTE 2: For BS supporting multi-band operation with Inter RF Bandwidth gap < 20 MHz the test requirement within the Inter RF Bandwidth gaps is calculated as a cumulative sum of contributions from adjacent sub-blocks or Base Station RF Bandwidth on each side of the Inter RF Bandwidth gap.

Table 4.2.2.8-2: Medium Range BS operating band unwanted emission limits for 1,4 MHz channel bandwidth, $31 < P_{\max,c} \leq 38$ dBm (E-UTRA bands > 3 GHz)

Frequency offset of measurement filter -3 dB point, Δf	Frequency offset of measurement filter centre frequency, f_{offset}	Test requirement (notes 1 and 2)	Measurement bandwidth
$0 \text{ MHz} \leq \Delta f < 1,4 \text{ MHz}$	$0,05 \text{ MHz} \leq f_{\text{offset}} < 1,45 \text{ MHz}$	$P_{\max,c} - 43,2 \text{ dB} - \frac{10}{1,4} \times \left(\frac{f_{\text{offset}}}{\text{MHz}} - 0,05 \right) \text{ dB}$	100 kHz
$1,4 \text{ MHz} \leq \Delta f < 2,8 \text{ MHz}$	$1,45 \text{ MHz} \leq f_{\text{offset}} < 2,85 \text{ MHz}$	$P_{\max,c} - 53,2 \text{ dB}$	100 kHz
$2,8 \text{ MHz} \leq \Delta f \leq \Delta f_{\max}$	$2,85 \text{ MHz} \leq f_{\text{offset}} < f_{\text{offset}_{\max}}$	-25 dBm	100 kHz

NOTE 1: For a BS supporting non-contiguous spectrum operation within any operating band the test requirement test requirement within sub-block gaps is calculated as a cumulative sum contributions from of adjacent sub-blocks on each side of the sub-block gap. Exception is $\Delta f \geq 10$ MHz from both adjacent sub-blocks on each side of the sub-block gap, where the test requirement within sub-block gaps shall be -25 dBm/100 kHz.

NOTE 2: For BS supporting multi-band operation with Inter RF Bandwidth gap < 20 MHz the test requirement within the Inter RF Bandwidth gaps is calculated as a cumulative sum of contributions from adjacent sub-blocks or Base Station RF Bandwidth on each side of the Inter RF Bandwidth gap.

Table 4.2.2.8-3: Medium Range BS operating band unwanted emission limits for 1,4 MHz channel bandwidth, $P_{\max,c} \leq 31$ dBm (E-UTRA bands ≤ 3 GHz)

Frequency offset of measurement filter -3 dB point, Δf	Frequency offset of measurement filter centre frequency, f_{offset}	Test requirement (notes 1 and 2)	Measurement bandwidth
$0 \text{ MHz} \leq \Delta f < 1,4 \text{ MHz}$	$0,05 \text{ MHz} \leq f_{\text{offset}} < 1,45 \text{ MHz}$	$-12,5 \text{ dB} - \frac{10}{1,4} \times \left(\frac{f_{\text{offset}}}{\text{MHz}} - 0,05 \right) \text{ dB}$	100 kHz
$1,4 \text{ MHz} \leq \Delta f < 2,8 \text{ MHz}$	$1,45 \text{ MHz} \leq f_{\text{offset}} < 2,85 \text{ MHz}$	-22,5 dBm	100 kHz
$2,8 \text{ MHz} \leq \Delta f \leq \Delta f_{\max}$	$2,85 \text{ MHz} \leq f_{\text{offset}} < f_{\text{offset}_{\max}}$	-25 dBm	100 kHz

NOTE 1: For a BS supporting non-contiguous spectrum operation within any operating band the test requirement within sub-block gaps is calculated as a cumulative sum of contributions from adjacent sub-blocks on each side of the sub-block gap. Exception is $\Delta f \geq 10$ MHz from both adjacent sub-blocks on each side of the sub-block gap, where the test requirement within sub-block gaps shall be -25 dBm/100 kHz.

NOTE 2: For BS supporting multi-band operation with Inter RF Bandwidth gap < 20 MHz the test requirement within the Inter RF Bandwidth gaps is calculated as a cumulative sum of contributions from adjacent sub-blocks or Base Station RF Bandwidth on each side of the Inter RF Bandwidth gap.

Table 4.2.2.8-4: Medium Range BS operating band unwanted emission limits for 1,4 MHz channel bandwidth, $P_{\max,c} \leq 31$ dBm (E-UTRA bands > 3 GHz)

Frequency offset of measurement filter -3 dB point, Δf	Frequency offset of measurement filter centre frequency, f_{offset}	Test requirement (notes 1 and 2)	Measurement bandwidth
$0 \text{ MHz} \leq \Delta f < 1,4 \text{ MHz}$	$0,05 \text{ MHz} \leq f_{\text{offset}} < 1,45 \text{ MHz}$	$-12,2 \text{ dBm} - \frac{10}{1,4} \times \left(\frac{f_{\text{offset}}}{\text{MHz}} - 0,05 \right) \text{ dB}$	100 kHz
$1,4 \text{ MHz} \leq \Delta f < 2,8 \text{ MHz}$	$1,45 \text{ MHz} \leq f_{\text{offset}} < 2,85 \text{ MHz}$	-22,2 dBm	100 kHz
$2,8 \text{ MHz} \leq \Delta f \leq \Delta f_{\max}$	$2,85 \text{ MHz} \leq f_{\text{offset}} < f_{\text{offset}_{\max}}$	-25 dBm	100 kHz

NOTE 1: For a BS supporting non-contiguous spectrum operation within any operating band the test requirement within sub-block gaps is calculated as a cumulative sum of contributions from adjacent sub-blocks on each side of the sub-block gap. Exception is $\Delta f \geq 10$ MHz from both adjacent sub-blocks on each side of the sub-block gap, where the test requirement within sub-block gaps shall be -25 dBm/100 kHz.

NOTE 2: For BS supporting multi-band operation with Inter RF Bandwidth gap < 20 MHz the test requirement within the Inter RF Bandwidth gaps is calculated as a cumulative sum of contributions from adjacent sub-blocks or Base Station RF Bandwidth on each side of the Inter RF Bandwidth gap.

Table 4.2.2.8-5: Medium Range BS operating band unwanted emission limits for 3 MHz channel bandwidth, $31 < P_{\max,c} \leq 38$ dBm (E-UTRA bands ≤ 3 GHz)

Frequency offset of measurement filter -3 dB point, Δf	Frequency offset of measurement filter centre frequency, f_{offset}	Test requirement (notes 1 and 2)	Measurement bandwidth
$0 \text{ MHz} \leq \Delta f < 3 \text{ MHz}$	$0,05 \text{ MHz} \leq f_{\text{offset}} < 3,05 \text{ MHz}$	$P_{\max,c} - 47,5 \text{ dB} - \frac{10}{3} \times \left(\frac{f_{\text{offset}}}{\text{MHz}} - 0,05 \right) \text{ dB}$	100 kHz
$3 \text{ MHz} \leq \Delta f < 6 \text{ MHz}$	$3,05 \text{ MHz} \leq f_{\text{offset}} < 6,05 \text{ MHz}$	$P_{\max,c} - 57,5 \text{ dB}$	100 kHz
$6 \text{ MHz} \leq \Delta f \leq \Delta f_{\max}$	$6,05 \text{ MHz} \leq f_{\text{offset}} < f_{\text{offset}_{\max}}$	$\min(P_{\max,c} - 59 \text{ dB}, -25 \text{ dBm})$	100 kHz

NOTE 1: For a BS supporting non-contiguous spectrum operation within any operating band the test requirement within sub-block gaps is calculated as a cumulative sum of contributions from adjacent sub-blocks on each side of the sub-block gap. Exception is $\Delta f \geq 10$ MHz from both adjacent sub-blocks on each side of the sub-block gap, where the test requirement within sub-block gaps shall be $\min(P_{\max,c} - 59 \text{ dB}, -25 \text{ dBm})/100$ kHz.

NOTE 2: For BS supporting multi-band operation with Inter RF Bandwidth gap < 20 MHz the test requirement within the Inter RF Bandwidth gaps is calculated as a cumulative sum of contributions from adjacent sub-blocks or Base Station RF Bandwidth on each side of the Inter RF Bandwidth gap.

Table 4.2.2.8-6: Medium Range BS operating band unwanted emission limits for 3 MHz channel bandwidth, $31 < P_{\max,c} \leq 38$ dBm (E-UTRA bands > 3 GHz)

Frequency offset of measurement filter -3 dB point, Δf	Frequency offset of measurement filter centre frequency, f_{offset}	Test requirement (notes 1 and 2)	Measurement bandwidth
$0 \text{ MHz} \leq \Delta f < 3 \text{ MHz}$	$0,05 \text{ MHz} \leq f_{\text{offset}} < 3,05 \text{ MHz}$	$P_{\max,c} - 47,2 \text{ dB} - \frac{10}{3} \times \left(\frac{f_{\text{offset}}}{\text{MHz}} - 0,05 \right) \text{ dB}$	100 kHz
$3 \text{ MHz} \leq \Delta f < 6 \text{ MHz}$	$3,05 \text{ MHz} \leq f_{\text{offset}} < 6,05 \text{ MHz}$	$P_{\max,c} - 57,2 \text{ dB}$	100 kHz
$6 \text{ MHz} \leq \Delta f \leq \Delta f_{\max}$	$6,05 \text{ MHz} \leq f_{\text{offset}} < f_{\text{offset}_{\max}}$	$\text{Min}(P_{\max,c} - 59 \text{ dB}, -25 \text{ dBm})$	100 kHz

NOTE 1: For a BS supporting non-contiguous spectrum operation within any operating band the test requirement within sub-block gaps is calculated as a cumulative sum of contributions from adjacent sub-blocks on each side of the sub-block gap. Exception is $\Delta f \geq 10$ MHz from both adjacent sub-blocks on each side of the sub-block gap, where the test requirement within sub-block gaps shall be $\min(P_{\max,c} - 59 \text{ dB}, -25 \text{ dBm})/100$ kHz.

NOTE 2: For BS supporting multi-band operation with Inter RF Bandwidth gap < 20 MHz the test requirement within the Inter RF Bandwidth gaps is calculated as a cumulative sum of contributions from adjacent sub-blocks or Base Station RF Bandwidth on each side of the Inter RF Bandwidth gap.

Table 4.2.2.2.8-7: Medium Range BS operating band unwanted emission limits for 3 MHz channel bandwidth, $P_{\max,c} \leq 31$ dBm (E-UTRA bands ≤ 3 GHz)

Frequency offset of measurement filter -3 dB point, Δf	Frequency offset of measurement filter centre frequency, f_{offset}	Test requirement (notes 1 and 2)	Measurement bandwidth
$0 \text{ MHz} \leq \Delta f < 3 \text{ MHz}$	$0,05 \text{ MHz} \leq f_{\text{offset}} < 3,05 \text{ MHz}$	$-16,5 \text{ dBm} - \frac{10}{3} \times \left(\frac{f_{\text{offset}}}{\text{MHz}} - 0,05 \right) \text{ dB}$	100 kHz
$3 \text{ MHz} \leq \Delta f < 6 \text{ MHz}$	$3,05 \text{ MHz} \leq f_{\text{offset}} < 6,05 \text{ MHz}$	-26,5 dBm	100 kHz
$6 \text{ MHz} \leq \Delta f \leq \Delta f_{\max}$	$6,05 \text{ MHz} \leq f_{\text{offset}} < f_{\text{offset}_{\max}}$	-28 dBm	100 kHz

NOTE 1: For a BS supporting non-contiguous spectrum operation within any operating band the test requirement within sub-block gaps is calculated as a cumulative sum of contributions from adjacent sub-blocks on each side of the sub-block gap. Exception is $\Delta f \geq 10$ MHz from both adjacent sub-blocks on each side of the sub-block gap, where the test requirement within sub-block gaps shall be -28 dBm/100 kHz.

NOTE 2: For BS supporting multi-band operation with Inter RF Bandwidth gap < 20 MHz the test requirement within the Inter RF Bandwidth gaps is calculated as a cumulative sum of contributions from adjacent sub-blocks or Base Station RF Bandwidth on each side of the Inter RF Bandwidth gap.

Table 4.2.2.2.8-8: Medium Range BS operating band unwanted emission limits for 3 MHz channel bandwidth, $P_{\max,c} \leq 31$ dBm (E-UTRA bands > 3 GHz)

Frequency offset of measurement filter -3 dB point, Δf	Frequency offset of measurement filter centre frequency, f_{offset}	Test requirement (notes 1 and 2)	Measurement bandwidth
$0 \text{ MHz} \leq \Delta f < 3 \text{ MHz}$	$0,05 \text{ MHz} \leq f_{\text{offset}} < 3,05 \text{ MHz}$	$-16,2 \text{ dBm} - \frac{10}{3} \times \left(\frac{f_{\text{offset}}}{\text{MHz}} - 0,05 \right) \text{ dB}$	100 kHz
$3 \text{ MHz} \leq \Delta f < 6 \text{ MHz}$	$3,05 \text{ MHz} \leq f_{\text{offset}} < 6,05 \text{ MHz}$	-26,2 dBm	100 kHz
$6 \text{ MHz} \leq \Delta f \leq \Delta f_{\max}$	$6,05 \text{ MHz} \leq f_{\text{offset}} < f_{\text{offset}_{\max}}$	-28 dBm	100 kHz

NOTE 1: For a BS supporting non-contiguous spectrum operation within any operating band the test requirement within sub-block gaps is calculated as a cumulative sum of contributions from adjacent sub-blocks on each side of the sub-block gap. Exception is $\Delta f \geq 10$ MHz from both adjacent sub-blocks on each side of the sub-block gap, where the test requirement within sub-block gaps shall be -28 dBm/100 kHz.

NOTE 2: For BS supporting multi-band operation with Inter RF Bandwidth gap < 20 MHz the test requirement within the Inter RF Bandwidth gaps is calculated as a cumulative sum of contributions from adjacent sub-blocks or Base Station RF Bandwidth on each side of the Inter RF Bandwidth gap.

Table 4.2.2.2.8-9: Medium Range BS operating band unwanted emission limits for 5, 10, 15 and 20 MHz channel bandwidth, $31 < P_{\max,c} \leq 38$ dBm (E-UTRA bands ≤ 3 GHz)

Frequency offset of measurement filter -3 dB point, Δf	Frequency offset of measurement filter centre frequency, f_{offset}	Test requirement (notes 1 and 3)	Measurement bandwidth
$0 \text{ MHz} \leq \Delta f < 5 \text{ MHz}$	$0,05 \text{ MHz} \leq f_{\text{offset}} < 5,05 \text{ MHz}$	$P - 51,5 \text{ dB} - \frac{7}{5} \times \left(\frac{f_{\text{offset}}}{\text{MHz}} - 0,05 \right) \text{ dB}$	100 kHz
$5 \text{ MHz} \leq \Delta f < \min(10 \text{ MHz}, \Delta f_{\max})$	$5,05 \text{ MHz} \leq f_{\text{offset}} < \min(10,05 \text{ MHz}, f_{\text{offset}_{\max}})$	$P_{\max,c} - 58,5 \text{ dB}$	100 kHz
$10 \text{ MHz} \leq \Delta f \leq \Delta f_{\max}$	$10,05 \text{ MHz} \leq f_{\text{offset}} < f_{\text{offset}_{\max}}$	$\min(P_{\max,c} - 60 \text{ dB}, -25 \text{ dBm})$ (note 2)	100 kHz

NOTE 1: For a BS supporting non-contiguous spectrum operation within any operating band the test requirement within sub-block gaps is calculated as a cumulative sum of contributions from adjacent sub-blocks on each side of the sub-block gap. Exception is $\Delta f \geq 10$ MHz from both adjacent sub-blocks on each side of the sub-block gap, where the test requirement within sub-block gaps shall be $\min(P_{\max,c} - 60 \text{ dB}, -25 \text{ dBm})/100$ kHz.

NOTE 2: The requirement is not applicable when $\Delta f_{\max} < 10$ MHz.

NOTE 3: For BS supporting multi-band operation with Inter RF Bandwidth gap < 20 MHz the test requirement within the Inter RF Bandwidth gaps is calculated as a cumulative sum of contributions from adjacent sub-blocks or Base Station RF Bandwidth on each side of the Inter RF Bandwidth gap.

Table 4.2.2.8-10: Medium Range BS operating band unwanted emission limits for 5, 10, 15 and 20 MHz channel bandwidth, $31 < P_{\max,c} \leq 38$ dBm (E-UTRA bands > 3 GHz)

Frequency offset of measurement filter -3 dB point, Δf	Frequency offset of measurement filter centre frequency, f_{offset}	Test requirement (notes 1 and 3)	Measurement bandwidth
$0 \text{ MHz} \leq \Delta f < 5 \text{ MHz}$	$0,05 \text{ MHz} \leq f_{\text{offset}} < 5,05 \text{ MHz}$	$P_{\max,c} - 51,2 \text{ dB} - \frac{7}{5} \times \left(\frac{f_{\text{offset}}}{\text{MHz}} - 0,05 \right) \text{ dB}$	100 kHz
$5 \text{ MHz} \leq \Delta f < \min(10 \text{ MHz}, \Delta f_{\max})$	$5,05 \text{ MHz} \leq f_{\text{offset}} < \min(10,05 \text{ MHz}, f_{\text{offset}_{\max}})$	$P_{\max,c} - 58,2 \text{ dB}$	100 kHz
$10 \text{ MHz} \leq \Delta f \leq \Delta f_{\max}$	$10,05 \text{ MHz} \leq f_{\text{offset}} < f_{\text{offset}_{\max}}$	$\min(P_{\max,c} - 60 \text{ dB}, -25 \text{ dBm})$ (note 2)	100 kHz

NOTE 1: For a BS supporting non-contiguous spectrum operation within any operating band the test requirement within sub-block gaps is calculated as a cumulative sum of contributions from adjacent sub-blocks on each side of the sub-block gap. Exception is $\Delta f \geq 10$ MHz from both adjacent sub-blocks on each side of the sub-block gap, where the test requirement within sub-block gaps shall be $\min(P_{\max,c} - 60 \text{ dB}, -25 \text{ dBm})/100 \text{ kHz}$.

NOTE 2: The requirement is not applicable when $\Delta f_{\max} < 10$ MHz.

NOTE 3: For BS supporting multi-band operation with Inter RF Bandwidth gap < 20 MHz the test requirement within the Inter RF Bandwidth gaps is calculated as a cumulative sum of contributions from adjacent sub-blocks or Base Station RF Bandwidth on each side of the Inter RF Bandwidth gap.

Table 4.2.2.8-11: Medium Range BS operating band unwanted emission limits for 5, 10, 15 and 20 MHz channel bandwidth, $P_{\max,c} \leq 31$ dBm (E-UTRA bands ≤ 3 GHz)

Frequency offset of measurement filter -3 dB point, Δf	Frequency offset of measurement filter centre frequency, f_{offset}	Test requirement (notes 1 and 3)	Measurement bandwidth
$0 \text{ MHz} \leq \Delta f < 5 \text{ MHz}$	$0,05 \text{ MHz} \leq f_{\text{offset}} < 5,05 \text{ MHz}$	$-20,5 \text{ dB} - \frac{7}{5} \times \left(\frac{f_{\text{offset}}}{\text{MHz}} - 0,05 \right) \text{ dB}$	100 kHz
$5 \text{ MHz} \leq \Delta f < \min(10 \text{ MHz}, \Delta f_{\max})$	$5,05 \text{ MHz} \leq f_{\text{offset}} < \min(10,05 \text{ MHz}, f_{\text{offset}_{\max}})$	-27,5 dBm	100 kHz
$10 \text{ MHz} \leq \Delta f \leq \Delta f_{\max}$	$10,05 \text{ MHz} \leq f_{\text{offset}} < f_{\text{offset}_{\max}}$	-29 dBm (note 2)	100 kHz

NOTE 1: For a BS supporting non-contiguous spectrum operation within any operating band the test requirement within sub-block gaps is calculated as a cumulative sum of contributions from adjacent sub-blocks on each side of the sub-block gap. Exception is $\Delta f \geq 10$ MHz from both adjacent sub-blocks on each side of the sub-block gap, where the test requirement within sub-block gaps shall be -29 dBm/100 kHz.

NOTE 2: The requirement is not applicable when $\Delta f_{\max} < 10$ MHz.

NOTE 3: For BS supporting multi-band operation with Inter RF Bandwidth gap < 20 MHz the test requirement within the Inter RF Bandwidth gaps is calculated as a cumulative sum of contributions from adjacent sub-blocks or Base Station RF Bandwidth on each side of the Inter RF Bandwidth gap.

Table 4.2.2.8-12: Medium Range BS operating band unwanted emission limits for 5, 10, 15 and 20 MHz channel bandwidth, $P_{\max,c} \leq 31$ dBm (E-UTRA bands > 3 GHz)

Frequency offset of measurement filter -3 dB point, Δf	Frequency offset of measurement filter centre frequency, f_{offset}	Test requirement (notes 1 and 3)	Measurement bandwidth
$0 \text{ MHz} \leq \Delta f < 5 \text{ MHz}$	$0,05 \text{ MHz} \leq f_{\text{offset}} < 5,05 \text{ MHz}$	$-20,2 \text{ dB} - \frac{7}{5} \times \left(\frac{f_{\text{offset}}}{\text{MHz}} - 0,05 \right) \text{ dB}$	100 kHz
$5 \text{ MHz} \leq \Delta f < \min(10 \text{ MHz}, \Delta f_{\max})$	$5,05 \text{ MHz} \leq f_{\text{offset}} < \min(10,05 \text{ MHz}, f_{\text{offset}_{\max}})$	-27,2 dBm	100 kHz
$10 \text{ MHz} \leq \Delta f \leq \Delta f_{\max}$	$10,05 \text{ MHz} \leq f_{\text{offset}} < f_{\text{offset}_{\max}}$	-29 dBm (note 2)	100 kHz

NOTE 1: For a BS supporting non-contiguous spectrum operation within any operating band the test requirement within sub-block gaps is calculated as a cumulative sum of contributions from adjacent sub-blocks on each side of the sub-block gap. Exception is $\Delta f \geq 10$ MHz from both adjacent sub-blocks on each side of the sub-block gap, where the test requirement within sub-block gaps shall be -29 dBm/100 kHz.

NOTE 2: The requirement is not applicable when $\Delta f_{\max} < 10$ MHz.

NOTE 3: For BS supporting multi-band operation with Inter RF Bandwidth gap < 20 MHz the test requirement within the Inter RF Bandwidth gaps is calculated as a cumulative sum of contributions from adjacent sub-blocks or Base Station RF Bandwidth on each side of the Inter RF Bandwidth gap.

4.2.2.2.9 Additional limits for operation in band 32

For a BS operating in band 32, additional limits are described in clause 6.6.3.5.3 of ETSI TS 136 141 [1]. This statement is provided for information and does not have any impact on the conformance requirements or essential radio test suites in the present document.

4.2.2.2.10 Minimum requirements for Local Area and Medium Range BS in band 46

For Local Area and Medium Range BS operating in band 46, emissions shall not exceed the maximum levels specified in table 4.2.2.2.10-1.

Table 4.2.2.2.10-1: Local Area and Medium Range BS operating band unwanted emission limits in band 46 for 20 MHz channel bandwidth

Frequency offset of measurement filter -3 dB point, Δf	Frequency offset of measurement filter centre frequency, f_{offset}	Minimum requirement (note)	Measurement bandwidth
$0 \text{ MHz} \leq \Delta f < 1 \text{ MHz}$	$0,05 \text{ MHz} \leq f_{\text{offset}} < 1,05 \text{ MHz}$	$P_{\max,c} - 32,6 \text{ dB} - 10 \left(\frac{f_{\text{offset}}}{\text{MHz}} - 0,05 \right) \text{ dB}$	100 kHz
$1 \text{ MHz} \leq \Delta f < \min(10 \text{ MHz}, \Delta f_{\max})$	$1,05 \text{ MHz} \leq f_{\text{offset}} < \min(10,05 \text{ MHz}, f_{\text{offset}_{\max}})$	$P_{\max,c} - 42,6 \text{ dB} - \frac{8}{9} \left(\frac{f_{\text{offset}}}{\text{MHz}} - 1,05 \right) \text{ dB}$	100 kHz
$10 \text{ MHz} \leq \Delta f < \min(20 \text{ MHz}, \Delta f_{\max})$	$10,05 \text{ MHz} \leq f_{\text{offset}} < \min(20,05 \text{ MHz}, f_{\text{offset}_{\max}})$	$P_{\max,c} - 50,6 \text{ dB} - \frac{12}{10} \left(\frac{f_{\text{offset}}}{\text{MHz}} - 10,05 \right) \text{ dB}$	100 kHz
$20 \text{ MHz} \leq \Delta f < \min(170 \text{ MHz}, \Delta f_{\max})$	$20,05 \text{ MHz} \leq f_{\text{offset}} < \min(170,05 \text{ MHz}, f_{\text{offset}_{\max}})$	$\text{Max}(P_{\max,c} - 62,6 \text{ dB} ; -40 \text{ dBm})$	100 kHz
$170 \text{ MHz} \leq \Delta f < \min(206 \text{ MHz}, \Delta f_{\max})$	$170,05 \text{ MHz} \leq f_{\text{offset}} < \min(206,05 \text{ MHz}, f_{\text{offset}_{\max}})$	$\text{Max}(P_{\max,c} - 64,6 \text{ dB}, -40 \text{ dBm})$	100 kHz
$206 \text{ MHz} \leq \Delta f \leq \Delta f_{\max}$	$206,05 \text{ MHz} \leq f_{\text{offset}} < f_{\text{offset}_{\max}}$	$\text{Max}(P_{\max,c} - 69,6 \text{ dB}, -40 \text{ dBm})$	100 kHz

NOTE: For a BS supporting non-contiguous spectrum operation within any operating band, the minimum requirement within sub-block gaps is calculated as a cumulative sum of contributions from adjacent sub blocks on each side of the sub block gap. Exception is $\Delta f \geq 20$ MHz from both adjacent sub blocks on each side of the sub-block gap, where the minimum requirement within sub-block gaps shall be $\text{Max}(P_{\max,c} - 62,6 \text{ dB}, -40 \text{ dB})/100$ kHz.

4.2.2.2.11 Minimum requirements for stand-alone NB-IoT Wide Area BS

For stand-alone NB-IoT BS in E-UTRA bands ≤ 3 GHz, emissions shall not exceed the maximum levels specified in table 4.2.2.2.11-1.

Table 4.2.2.2.11-1: Stand-alone NB-IoT BS operating band unwanted emission limits (E-UTRA bands ≤ 3 GHz)

Frequency offset of measurement filter -3 dB point, Δf	Frequency offset of measurement filter centre frequency, f_{offset}	Minimum requirement (notes 1, 2, 3 and 4)	Measurement bandwidth
$0 \text{ MHz} \leq \Delta f < 0,05 \text{ MHz}$	$0,015 \text{ MHz} \leq f_{\text{offset}} < 0,065 \text{ MHz}$	$\text{Max}(6,5 \text{ dBm} - 60 \cdot \left(\frac{f_{\text{offset}}}{\text{MHz}} - 0,015\right) \text{ dB} + X \text{ dB} - 12,5 \text{ dBm})$	30 kHz
$0,05 \text{ MHz} \leq \Delta f < 0,15 \text{ MHz}$	$0,065 \text{ MHz} \leq f_{\text{offset}} < 0,165 \text{ MHz}$	$\text{Max}(3,5 \text{ dBm} - 160 \cdot \left(\frac{f_{\text{offset}}}{\text{MHz}} - 0,065\right) \text{ dB} + X \text{ dB} - 12,5 \text{ dBm})$	30 kHz
$0,15 \text{ MHz} \leq \Delta f < 0,2 \text{ MHz}$ (note 1)	$0,165 \text{ MHz} \leq f_{\text{offset}} < 0,215 \text{ MHz}$	-12,5 dBm	30 kHz
$0,2 \text{ MHz} \leq \Delta f < 1 \text{ MHz}$	$0,215 \text{ MHz} \leq f_{\text{offset}} < 1,015 \text{ MHz}$	$-12,5 \text{ dBm} - 15 \cdot \left(\frac{f_{\text{offset}}}{\text{MHz}} - 0,215\right) \text{ dB}$	30 kHz
(note 5)	$1,015 \text{ MHz} \leq f_{\text{offset}} < 1,5 \text{ MHz}$	-24,5 dBm	30 kHz
$1 \text{ MHz} \leq \Delta f \leq \min(\Delta f_{\text{max}}, 10 \text{ MHz})$	$1,5 \text{ MHz} \leq f_{\text{offset}} < \min(f_{\text{offset}_{\text{max}}}, 10,5 \text{ MHz})$	-11,5 dBm	1 MHz
$10 \text{ MHz} \leq \Delta f \leq \Delta f_{\text{max}}$	$10,5 \text{ MHz} \leq f_{\text{offset}} < f_{\text{offset}_{\text{max}}}$	-15 dBm (note 6)	1 MHz

NOTE 1: The limits in this table only apply for operation with a standalone NB-IoT carrier adjacent to the Base Station RF Bandwidth edge.

NOTE 2: For a BS supporting non-contiguous spectrum operation within any operating band the minimum requirement within sub-block gaps is calculated as a cumulative sum of contributions from adjacent sub blocks on each side of the sub block gap.

NOTE 3: For a BS supporting multi-band operation with Inter RF Bandwidth gap < 20 MHz the minimum requirement within the Inter RF Bandwidth gaps is calculated as a cumulative sum of contributions from adjacent sub-blocks or RF Bandwidth on each side of the Inter RF Bandwidth gap.

NOTE 4: In case the carrier adjacent to the Base Station RF Bandwidth edge is a standalone NB-IoT carrier, the value of $X = P_{\text{NB-IoTcarrier}} - 43$, where $P_{\text{NB-IoTcarrier}}$ is the power level of the standalone NB-IoT carrier adjacent to the Base Station RF Bandwidth edge. In other cases, $X = 0$.

NOTE 5: This frequency range ensures that the range of values of f_{offset} is continuous.

NOTE 6: The requirement is not applicable when $\Delta f_{\text{max}} < 10 \text{ MHz}$.

4.2.2.3 Conformance

Conformance tests described in clause 5.3.1 shall be carried out.

4.2.3 Adjacent Channel Leakage Power Ratio (ACLR)

4.2.3.1 Definition

Unwanted emissions consist of out-of-band emissions and spurious emissions (Recommendation ITU-R SM.329-12 [i.4]). Out of band emissions are emissions immediately outside the channel bandwidth resulting from the modulation process and non-linearity in the transmitter but excluding spurious emissions. The out-of-band emissions requirement for the BS transmitter is specified both in terms of Adjacent Channel Leakage power Ratio (ACLR) and Operating band unwanted emissions.

Adjacent Channel Leakage power Ratio (ACLR) is the ratio of the filtered mean power centred on the assigned channel frequency to the filtered mean power centred on an adjacent channel frequency.

The requirements shall apply outside the Base Station RF Bandwidth or Maximum Radio Bandwidth whatever the type of transmitter considered (single carrier or multi-carrier) and for all transmission modes foreseen by the manufacturer's specification. The interfering signal offset is defined relative to the Base Station RF Bandwidth edges.

For a BS operating in non-contiguous spectrum, the ACLR shall also apply for the first adjacent channel inside any sub-block gap with a gap size $W_{\text{gap}} \geq 15$ MHz or $W_{\text{gap}} \geq 60$ MHz for band 46. The ACLR requirement for the second adjacent channel shall apply inside any sub-block gap with a gap size $W_{\text{gap}} \geq 20$ MHz or $W_{\text{gap}} \geq 60$ MHz for band 46. The CACLR requirement in clause 4.2.3.4.2 shall apply in sub-block gaps for the frequency ranges defined in table 4.2.3.4.2-1 for paired spectrum and table 4.2.3.4.2-2 for unpaired spectrum.

For a BS operating in multiple bands, where multiple bands are mapped onto the same antenna connector, the ACLR also shall apply for the first adjacent channel inside any Inter RF Bandwidth gap with a gap size $W_{\text{gap}} \geq 15$ MHz. The ACLR requirement for the second adjacent channel shall apply inside any Inter RF Bandwidth gap with a gap size $W_{\text{gap}} \geq 20$ MHz. The CACLR requirement in clause 4.2.3.4.2 shall apply in Inter RF Bandwidth gaps for the frequency ranges defined in table 4.2.3.4.2-1 for paired spectrum and table 4.2.3.4.2-2 for unpaired spectrum.

The requirement shall apply during the transmitter ON period.

4.2.3.2 Void

4.2.3.3 Void

4.2.3.4 Limits

4.2.3.4.1 ACLR Limits

The ACLR is defined with a square filter of bandwidth equal to the transmission bandwidth configuration of the transmitted signal (BW_{Config}) centred on the assigned channel frequency and a filter centred on the adjacent channel frequency according to tables 4.2.3.4.1-1 and 4.2.3.4.1-2.

For Wide Area BS, either the ACLR limits in tables 4.2.3.4.1-1 and 4.2.3.4.1-2 or the absolute limit of -15 dBm/MHz shall apply, whichever is less stringent.

For Medium Range BS, either the ACLR limits in the tables below or the absolute limit of -25 dBm/MHz shall apply, whichever is less stringent.

For Local Area BS, either the ACLR limits in tables 4.2.3.4.1-1 and 4.2.3.4.1-2 or the absolute limit of -32 dBm/MHz shall apply, whichever is less stringent.

For Home BS, either the ACLR limits in tables 4.2.3.4.1-1 and 4.2.3.4.1-2 or the absolute limit of -50 dBm/MHz shall apply, whichever is less stringent.

The ACLR requirements in tables 4.2.3.4.1-1 to 4.2.3.4.1-4 apply to BS that supports E-UTRA or E-UTRA with NB-IoT (in band and/or guard band), in any operating band, except for band 46. The ACLR requirements for band 46 are in tables 4.2.3.4.1-2A and 4.2.3.4.1-4A. The ACLR requirements in table 4.2.3.4.1-2B apply to BS that supports standalone NB-IoT.

For operation in paired spectrum, the ACLR shall be higher than the value specified in table 4.2.3.4.1-1.

Table 4.2.3.4.1-1: Base Station ACLR in paired spectrum

Channel bandwidth of E-UTRA lowest/highest carrier transmitted BW_{Channel} (MHz)	BS adjacent channel centre frequency offset below the lowest or above the highest carrier centre frequency transmitted	Assumed adjacent channel carrier (informative)	Filter on the adjacent channel frequency and corresponding filter bandwidth	ACLR limit
1,4; 3; 5; 10; 15; 20	BW_{Channel}	E-UTRA of same BW	Square (BW_{Config})	44,2 dB
	$2 \times BW_{\text{Channel}}$	E-UTRA of same BW	Square (BW_{Config})	44,2 dB
	$BW_{\text{Channel}}/2 + 2,5$ MHz	3,84 Mcps UTRA	RRC (3,84 Mcps)	44,2 dB
	$BW_{\text{Channel}}/2 + 7,5$ MHz	3,84 Mcps UTRA	RRC (3,84 Mcps)	44,2 dB

Channel bandwidth of E-UTRA lowest/highest carrier transmitted BW_{Channel} (MHz)	BS adjacent channel centre frequency offset below the lowest or above the highest carrier centre frequency transmitted	Assumed adjacent channel carrier (informative)	Filter on the adjacent channel frequency and corresponding filter bandwidth	ACLR limit
NOTE 1: BW_{Channel} and BW_{Config} are the channel bandwidth and transmission bandwidth configuration of the E-UTRA lowest/highest carrier transmitted on the assigned channel frequency.				
NOTE 2: The RRC filter shall be equivalent to the transmit pulse shape filter defined in ETSI TS 125 104 [2], with a chip rate as defined in this table.				

For operation in unpaired spectrum, the ACLR shall be higher than the value specified in table 4.2.3.4.1-2.

Table 4.2.3.4.1-2: Base Station ACLR in unpaired spectrum with synchronized operation

Channel bandwidth of E-UTRA lowest/highest carrier transmitted BW_{Channel} (MHz)	BS adjacent channel centre frequency offset below lowest or above the highest carrier centre frequency transmitted	Assumed adjacent channel carrier (informative)	Filter on the adjacent channel frequency and corresponding filter bandwidth	ACLR limit
1,4; 3	BW_{Channel}	E-UTRA of same BW	Square (BW_{Config})	44,2 dB
	$2 \times BW_{\text{Channel}}$	E-UTRA of same BW	Square (BW_{Config})	44,2 dB
	$BW_{\text{Channel}}/2 + 0,8 \text{ MHz}$	1,28 Mcps UTRA	RRC (1,28 Mcps)	44,2 dB
	$BW_{\text{Channel}}/2 + 2,4 \text{ MHz}$	1,28 Mcps UTRA	RRC (1,28 Mcps)	44,2 dB
5; 10; 15; 20	BW_{Channel}	E-UTRA of same BW	Square (BW_{Config})	44,2 dB
	$2 \times BW_{\text{Channel}}$	E-UTRA of same BW	Square (BW_{Config})	44,2 dB
	$BW_{\text{Channel}}/2 + 0,8 \text{ MHz}$	1,28 Mcps UTRA	RRC (1,28 Mcps)	44,2 dB
	$BW_{\text{Channel}}/2 + 2,4 \text{ MHz}$	1,28 Mcps UTRA	RRC (1,28 Mcps)	44,2 dB
	$BW_{\text{Channel}}/2 + 2,5 \text{ MHz}$	3,84 Mcps UTRA	RRC (3,84 Mcps)	44,2 dB
	$BW_{\text{Channel}}/2 + 7,5 \text{ MHz}$	3,84 Mcps UTRA	RRC (3,84 Mcps)	44,2 dB
	$BW_{\text{Channel}}/2 + 5 \text{ MHz}$	7,68 Mcps UTRA	RRC (7,68 Mcps)	44,2 dB
	$BW_{\text{Channel}}/2 + 15 \text{ MHz}$	7,68 Mcps UTRA	RRC (7,68 Mcps)	44,2 dB
NOTE 1: BW_{Channel} and BW_{Config} are the channel bandwidth and transmission bandwidth configuration of the E-UTRA lowest/highest carrier transmitted on the assigned channel frequency.				
NOTE 2: The RRC filter shall be equivalent to the transmit pulse shape filter defined in ETSI TS 125 105 [3], with a chip rate as defined in this table.				

For operation in unpaired spectrum, in band 46, the ACLR shall be higher than the value specified in table 4.2.3.4.1-2A.

Table 4.2.3.4.1-2A: Base Station ACLR in band 46

Channel bandwidth of E-UTRA lowest/highest carrier transmitted BW_{Channel} [MHz]	BS adjacent channel centre frequency offset below the lowest or above the highest carrier centre frequency transmitted	Assumed adjacent channel carrier (informative)	Filter on the adjacent channel frequency and corresponding filter bandwidth	ACLR limit
20	BW_{Channel}	E-UTRA of same BW	Square (BW_{Config})	35 dB
	$2 \times BW_{\text{Channel}}$	E-UTRA of same BW	Square (BW_{Config})	40 dB
NOTE: BW_{Channel} and BW_{Config} are the channel bandwidth and transmission bandwidth configuration of the E-UTRA lowest/highest carrier transmitted on the assigned channel frequency.				

For stand-alone NB-IoT operation in paired spectrum, the ACLR shall be higher than the value specified in table 4.2.3.4.1-2B.

Table 4.2.3.4.1-2B: Base Station ACLR for stand-alone NB-IoT operation in paired spectrum

Channel bandwidth of NB-IoT lowest/highest carrier transmitted BW_{Channel} [kHz]	BS adjacent channel centre frequency offset below the lowest or above the highest carrier centre frequency transmitted	Assumed adjacent channel carrier (informative)	Filter on the adjacent channel frequency and corresponding filter bandwidth	ACLR limit
200	300 kHz	Stand-alone NB-IoT	Square (180 kHz)	39,2 dB
	500 kHz	Stand-alone NB-IoT	Square (180 kHz)	49,2 dB

For operation in non-contiguous paired spectrum, the ACLR shall be higher than the value specified in table 4.2.3.4.1-3.

Table 4.2.3.4.1-3: Base Station ACLR in non-contiguous paired spectrum

Sub-block gap size (W_{gap}) where the limit shall apply	BS adjacent channel centre frequency offset below or above the sub-block edge (inside the gap)	Assumed adjacent channel carrier (informative)	Filter on the adjacent channel frequency and corresponding filter bandwidth	ACLR limit
$W_{\text{gap}} \geq 15$ MHz	2,5 MHz	3,84 Mcps UTRA	RRC (3,84 Mcps)	44,2 dB
$W_{\text{gap}} \geq 20$ MHz	7,5 MHz	3,84 Mcps UTRA	RRC (3,84 Mcps)	44,2 dB
NOTE: The RRC filter shall be equivalent to the transmit pulse shape filter defined in ETSI TS 125 104 [2], with a chip rate as defined in this table.				

For operation in non-contiguous unpaired spectrum, the ACLR shall be higher than the value specified in table 4.2.3.4.1-4.

Table 4.2.3.4.1-4: Base Station ACLR in non-contiguous unpaired spectrum

Sub-block gap size (W_{gap}) where the limit shall apply	BS adjacent channel centre frequency offset below or above the sub-block edge (inside the gap)	Assumed adjacent channel carrier (informative)	Filter on the adjacent channel frequency and corresponding filter bandwidth	ACLR limit
$W_{\text{gap}} \geq 15$ MHz	2,5 MHz	5 MHz E-UTRA	Square (BW_{Config})	44,2 dB
$W_{\text{gap}} \geq 20$ MHz	7,5 MHz	5 MHz E-UTRA	Square (BW_{Config})	44,2 dB

For operation in non-contiguous spectrum in band 46, the ACLR shall be higher than the value specified in table 4.2.3.4.1-4A.

Table 4.2.3.4.1-4A: Base Station ACLR in non-contiguous spectrum in band 46

Sub-block gap size (W_{gap}) where the limit applies	BS adjacent channel centre frequency offset below or above the sub-block edge (inside the gap)	Assumed adjacent channel carrier (informative)	Filter on the adjacent channel frequency and corresponding filter bandwidth	ACLR limit
$W_{\text{gap}} \geq 60$ MHz	10 MHz	20 MHz E-UTRA carrier	Square (BW_{Config})	34,2 dB
$W_{\text{gap}} \geq 80$ MHz	30 MHz	20 MHz E-UTRA carrier	Square (BW_{Config})	34,2 dB

4.2.3.4.2 Cumulative ACLR test requirement in non-contiguous spectrum limits

The following requirement shall apply for the sub-block or Inter RF Bandwidth gap sizes listed in tables 4.2.3.4.2-1 to 4.2.3.4.2-2A:

- Inside a sub-block gap within an operating band for a BS operating in non-contiguous spectrum.

- Inside an Inter RF Bandwidth gap for a BS operating in multiple bands, where multiple bands are mapped on the same antenna connector.

The Cumulative Adjacent Channel Leakage power Ratio (CACLR) in a sub-block gap or Inter RF Bandwidth gap is the ratio of:

- the sum of the filtered mean power centred on the assigned channel frequencies for the two carriers adjacent to each side of the sub-block gap or Inter RF Bandwidth gap; and
- the filtered mean power centred on a frequency channel adjacent to one of the respective sub-block edges or Base Station RF Bandwidth edges.

The assumed filter for the adjacent channel frequency is defined in table 4.2.3.4.2-1 for paired spectrum and table 4.2.3.4.2-2 for unpaired spectrum. Filters on the assigned channels are defined in table 4.2.3.4.2-3.

For Wide Area BS, either the CACLR limits in table 4.2.3.4.2-1 for paired spectrum and table 4.2.3.4.2-2 for unpaired spectrum, or the absolute limit of -15 dBm/MHz shall apply, whichever is less stringent.

For Medium Range BS, either the CACLR limits in table 4.2.3.4.2-1 for paired spectrum and table 4.2.3.4.2-2 for unpaired spectrum, or the absolute limit of -25 dBm/MHz shall apply, whichever is less stringent.

For Local Area BS, either the CACLR limits in table 4.2.3.4.2-1 for paired spectrum and table 4.2.3.4.2-2 for unpaired spectrum, or the absolute limit of -32 dBm/MHz shall apply, whichever is less stringent.

The ACLR requirements in tables 4.2.3.4.2-1 and 4.2.3.4.2-2 shall apply in all operating bands, except for band 46. The ACLR requirements for band 46 are in table 4.2.3.4.2-A.

For operation in non-contiguous spectrum or multiple bands, the CACLR for E-UTRA carriers located on either side of the sub-block gap or Inter RF Bandwidth gap shall be higher than the value specified in table 4.2.3.4.2-1 for paired spectrum and table 4.2.3.4.2-2 for unpaired spectrum.

Table 4.2.3.4.2-1: Base Station CACLR in non-contiguous paired spectrum

Sub-block or Inter RF Bandwidth gap size (W_{gap}) where the limit shall apply	BS adjacent channel centre frequency offset below or above the sub-block edge or Inter RF Bandwidth edge (inside the gap)	Assumed adjacent channel carrier (informative)	Filter on the adjacent channel frequency and corresponding filter bandwidth	CACLR limit
$5 \text{ MHz} \leq W_{\text{gap}} < 15 \text{ MHz}$	2,5 MHz	3,84 Mcps UTRA	RRC (3,84 Mcps)	44,2 dB
$10 \text{ MHz} < W_{\text{gap}} < 20 \text{ MHz}$	7,5 MHz	3,84 Mcps UTRA	RRC (3,84 Mcps)	44,2 dB
NOTE: The RRC filter shall be equivalent to the transmit pulse shape filter defined in ETSI TS 125 104 [2], with a chip rate as defined in this table.				

Table 4.2.3.4.2-2: Base Station CACLR in non-contiguous unpaired spectrum

Sub-block or Inter RF Bandwidth gap size (W_{gap}) where the limit shall apply	BS adjacent channel centre frequency offset below or above the sub-block edge or Inter RF Bandwidth edge (inside the gap)	Assumed adjacent channel carrier (informative)	Filter on the adjacent channel frequency and corresponding filter bandwidth	CACLR limit
$5 \text{ MHz} \leq W_{\text{gap}} < 15 \text{ MHz}$	2,5 MHz	5 MHz E-UTRA carrier	Square (BW_{Config})	44,2 dB
$10 \text{ MHz} < W_{\text{gap}} < 20 \text{ MHz}$	7,5 MHz	5 MHz E-UTRA carrier	Square (BW_{Config})	44,2 dB

For operation in non-contiguous spectrum in band 46, the CACLR for E-UTRA carriers located on either side of the sub-block gap shall be higher than the value specified in table 4.2.3.4.2-A.

Table 4.2.3.4.2-2A: Base Station CACLR in non-contiguous spectrum in band 46

Sub-block gap size (W_{gap}) where the limit applies	BS adjacent channel centre frequency offset below or above the sub-block edge (inside the gap)	Assumed adjacent channel carrier (informative)	Filter on the adjacent channel frequency and corresponding filter bandwidth	CACLR limit
$20 \text{ MHz} \leq W_{\text{gap}} < 60 \text{ MHz}$	10 MHz	20 MHz E-UTRA carrier	Square (BW_{Config})	35 dB
$40 \text{ MHz} < W_{\text{gap}} < 80 \text{ MHz}$	30 MHz	20 MHz E-UTRA carrier	Square (BW_{Config})	35 dB

Table 4.2.3.4.2-3: Filter parameters for the assigned channel

RAT of the carrier adjacent to the sub-block or Inter RF Bandwidth gap	Filter on the assigned channel frequency and corresponding filter bandwidth
E-UTRA	E-UTRA of same BW
NOTE: The RRC filter shall be equivalent to the transmit pulse shape filter defined in ETSI TS 125 104 [2], with a chip rate as defined in this table.	

4.2.3.5 Conformance

Conformance tests described in clause 5.3.2 shall be carried out.

4.2.4 Transmitter spurious emissions

4.2.4.1 Definition

Unwanted emissions consist of out-of-band emissions and spurious emissions (Recommendation ITU-R SM.329-12 [i.4]). Spurious emissions are emissions which are caused by unwanted transmitter effects such as harmonics emission, parasitic emission, intermodulation products and frequency conversion products, but exclude out-of-band emissions. This is measured at the Base Station antenna connector.

The transmitter spurious emission limits shall apply from 9 kHz to 12,75 GHz, excluding the frequency range from 10 MHz below the lowest frequency of the downlink operating band up to 10 MHz above the highest frequency of the downlink operating band (see table 1-1). For BS capable of multi-band operation where multiple bands are mapped on the same antenna connector, this exclusion applies for each supported operating band. For BS capable of multi-band operation where multiple bands are mapped on separate antenna connectors, the single-band requirements apply and the multi-band exclusions and provisions are not applicable. For some operating bands the upper frequency limit is higher than 12,75 GHz.

For a BS supporting multi-carrier, the unwanted emissions requirements shall apply to channel bandwidths of the outermost carrier larger than or equal to 5 MHz.

The requirements shall apply to BS that supports E-UTRA or E-UTRA with NB-IoT in-band/guard band operation or NB-IoT standalone operation.

The requirements shall apply whatever the type of transmitter considered (single carrier or multi-carrier) and for all transmission modes foreseen by the manufacturer's specification. Unless otherwise stated, all power levels related to the requirements are measured as mean power (RMS).

For an E-UTRA BS additionally conforming to ETSI EN 301 908-18 [7], either the requirement of the present clause or the Transmitter spurious emissions requirement in clause 4.2.4 of ETSI EN 301 908-18 [7] can be equally applied, as listed in table 4.2.1-2.

4.2.4.2 Limits

4.2.4.2.1 Spurious emissions

The power of any spurious emission shall not exceed the limits in table 4.2.4.2.1-1.

Table 4.2.4.2.1-1: BS Spurious emissions limits

Frequency range	Maximum Level	Measurement Bandwidth	Note
9 kHz ↔ 150 kHz	-36 dBm	1 kHz	Note 1
150 kHz ↔ 30 MHz	-36 dBm	10 kHz	Note 1
30 MHz ↔ 1 GHz	-36 dBm	100 kHz	Note 1
1 GHz ↔ 12,75 GHz	-30 dBm	1 MHz	Note 2
12,75 GHz ↔ 5 th harmonic of the upper frequency edge of the downlink operating band	-30 dBm	1 MHz	Notes 2 and 3
12,75 GHz ↔ 26 GHz	-30 dBm	1 MHz	Notes 2 and 4
NOTE 1: Bandwidth as in Recommendation ITU-R SM.329-12 [i.4], section 4.1.			
NOTE 2: Bandwidth as in Recommendation ITU-R SM.329-12 [i.4], section 4.1. Upper frequency as in Recommendation ITU-R SM.329-12 [i.4], section 2.5 table 1-1.			
NOTE 3: Shall apply only for bands 22, 42 and 43.			
NOTE 4: Applies only to band 46.			

4.2.4.2.2 Co-existence with other systems

This requirement shall be applied for the protection of UE/MS and BS/BTS receivers of other systems.

The power of any spurious emission shall not exceed the limit specified in table 4.2.4.2.2-1. For BS capable of multi-band operation the exclusions and conditions in the last column of table 4.2.4.2.2-1 shall apply for each supported operating band. For BS capable of multi-band operation where multiple bands are mapped on separate antenna connectors, the exclusions and conditions in the last column of table 4.2.4.2.2-1 shall apply for the operating band supported at that antenna connector.

Table 4.2.4.2.2-1: Spurious emissions limits for protection of other systems

Protected system	Frequency range for co-existence requirement	Maximum Level	Measurement Bandwidth	Exclusions and conditions
GSM900	921 MHz to 960 MHz	-57 dBm	100 kHz	This requirement shall not apply to E-UTRA BS operating in band 8.
	876 MHz to 915 MHz	-61 dBm	100 kHz	For the frequency range 880 MHz to 915 MHz, this requirement shall not apply to E-UTRA BS operating in band 8, since it is already covered by the requirement in clause 4.2.4.2.3.
DCS1800	1 805 MHz to 1 880 MHz	-47 dBm	100 kHz	This requirement shall not apply to E-UTRA BS operating in band 3.
	1 710 MHz to 1 785 MHz	-61 dBm	100 kHz	This requirement shall not apply to E-UTRA BS operating in band 3, since it is already covered by the requirement in clause 4.2.4.2.3.
UTRA FDD band I, E-UTRA band 1	2 110 MHz to 2 170 MHz	-52 dBm	1 MHz	This requirement shall not apply to E-UTRA BS operating in band 1 or 65.
	1 920 MHz to 1 980 MHz	-49 dBm	1 MHz	This requirement shall not apply to E-UTRA BS operating in band 1 or 65, since it is already covered by the requirement in clause 4.2.4.2.3.
UTRA FDD band III, E-UTRA band 3	1 805 MHz to 1 880 MHz	-52 dBm	1 MHz	This requirement shall not apply to E-UTRA BS operating in band 3.
	1 710 MHz to 1 785 MHz	-49 dBm	1 MHz	This requirement shall not apply to E-UTRA BS operating in band 3, since it is already covered by the requirement in clause 4.2.4.2.3.

Protected system	Frequency range for co-existence requirement	Maximum Level	Measurement Bandwidth	Exclusions and conditions
UTRA FDD band VII, E-UTRA band 7	2 620 MHz to 2 690 MHz	-52 dBm	1 MHz	This requirement shall not apply to E-UTRA BS operating in band 7.
	2 500 MHz to 2 570 MHz	-49 dBm	1 MHz	This requirement shall not apply to E-UTRA BS operating in band 7, since it is already covered by the requirement in clause 4.2.4.2.3.
UTRA FDD band VIII, E-UTRA band 8	925 MHz to 960 MHz	-52 dBm	1 MHz	This requirement shall not apply to E-UTRA BS operating in band 8.
	880 MHz to 915 MHz	-49 dBm	1 MHz	This requirement shall not apply to E-UTRA BS operating in band 8, since it is already covered by the requirement in clause 4.2.4.2.3.
UTRA FDD band XX, E-UTRA band 20	791 MHz to 821 MHz	-52 dBm	1 MHz	This requirement shall not apply to E-UTRA BS operating in band 20 or 28.
	832 MHz to 862 MHz	-49 dBm	1 MHz	This requirement shall not apply to E-UTRA BS operating in band 20, since it is already covered by the requirement in clause 4.2.4.2.3.
UTRA FDD band XXII, E-UTRA band 22	3 510 MHz to 3 590 MHz	-52 dBm	1 MHz	This requirement shall not apply to E-UTRA BS operating in band 22 or 42.
	3 410 MHz to 3 490 MHz	-49 dBm	1 MHz	This requirement shall not apply to E-UTRA BS operating in band 22, since it is already covered by the requirement in clause 4.2.4.2.3. This requirement shall not apply to E-UTRA BS operating in band 42.
E-UTRA band 28	758 MHz to 803 MHz	-52 dBm	1 MHz	This requirement shall not apply to E-UTRA BS operating in band 20, 28, 67 or 68.
	703 MHz to 748 MHz	-49 dBm	1 MHz	This requirement shall not apply to E-UTRA BS operating in band 28, since it is already covered by the requirement in clause 4.2.4.2.3. For BS operating in band 67, it applies for 703 MHz to 736 MHz. For E-UTRA BS operating in band 68, it applies for 728 MHz to 733 MHz.
E-UTRA band 31	462,5 MHz to 467,5 MHz	-52 dBm	1 MHz	This requirement shall not apply to BS operating in band 31.
	452,5 MHz to 457,5 MHz	-49 dBm	1 MHz	This requirement shall not apply to BS operating in band 31, since it is already covered by the requirement in clause 4.2.4.2.3.
UTRA FDD band XXXII or E-UTRA band 32	1 452 MHz to 1 496 MHz	-52 dBm	1 MHz	This requirement shall not apply to E-UTRA BS operating in band 32 (note 3).
UTRA TDD in band a), E-UTRA band 33	1 900 MHz to 1 920 MHz	-52 dBm	1 MHz	This requirement shall not apply to E-UTRA BS operating in band 33.
UTRA TDD in band a), E-UTRA band 34	2 010 MHz to 2 025 MHz	-52 dBm	1 MHz	This requirement shall not apply to E-UTRA BS operating in band 34.
UTRA TDD in band d), E-UTRA band 38	2 570 MHz to 2 620 MHz	-52 dBm	1 MHz	This requirement shall not apply to E-UTRA BS operating in band 38 or 68. For operation in band 7 see note 2.
UTRA TDD in band e), E-UTRA band 40	2 300 MHz to 2 400 MHz	-52 dBm	1 MHz	This requirement shall not apply to E-UTRA BS operating in band 40.
E-UTRA band 42	3 400 MHz to 3 600 MHz	-52 dBm	1 MHz	This requirement shall not apply to E-UTRA BS operating in band 22, 42 or 43.
E-UTRA band 43	3 600 MHz to 3 800 MHz	-52 dBm	1 MHz	This requirement shall not apply to E-UTRA BS operating in band 42 or 43.
E-UTRA band 46	5 150 MHz to 5 925 MHz	-52 dBm	1 MHz	This requirement shall not apply to E-UTRA BS operating in band 46 (note 4).
E-UTRA band 65	2 110 MHz to 2 200 MHz	-52 dBm	1 MHz	This requirement shall not apply to E-UTRA BS operating in band 1 or 65.
	1 920 MHz to 2 010 MHz	-49 dBm	1 MHz	This requirement shall not apply to E-UTRA BS operating in band 65, since it is already covered by the requirement in clause 4.2.4.2.3. For E-UTRA BS operating in band 1, it shall apply for 1 980 MHz to 2 010 MHz, while the rest is covered in clause 4.2.4.2.3.

Protected system	Frequency range for co-existence requirement	Maximum Level	Measurement Bandwidth	Exclusions and conditions
E-UTRA band 67	738 MHz to 758 MHz	-52 dBm	1 MHz	This requirement shall not apply to BS operating in band 28 or 67.
E-UTRA band 68	753 MHz to 783 MHz	-52 dBm	1 MHz	This requirement shall not apply to E-UTRA BS operating in band 28, or 68.
	698 MHz to 728 MHz	-49 dBm	1 MHz	This requirement shall not apply to E-UTRA BS operating in band 68, since it is already covered by the requirement in clause 4.2.4.2.3. For E-UTRA BS operating in band 28, it shall apply between 698 MHz and 703 MHz, while the rest is covered in clause 4.2.4.2.3.
E-UTRA band 69	2 570 MHz to 2 620 MHz	-52 dBm	1 MHz	This requirement shall not apply to E-UTRA BS operating in band 38 or 69.

NOTE 1: Where the table has two entries for the same or overlapping frequency ranges, both limits shall be applied.
NOTE 2: As set out in the definition in clause 4.2.4.1, except for the cases where the noted requirements apply to a BS operating in band 28, the co-existence requirements in this table shall not apply for the 10 MHz frequency range immediately outside the downlink operating band (see table 1-1). This is also the case when the downlink operating band is adjacent to the band for the protected system in the table.
NOTE 3: The co-existence requirement is specified for the full frequency range defined for band 32 in ETSI TS 136 141 [1].
NOTE 4: The co-existence requirement is specified for the full frequency range defined for band 46 in ETSI TS 136 141 [1].

4.2.4.2.3 Protection of the BS receiver of own or different BS

This requirement shall be applied in order to prevent the receivers of the BSs being desensitized by emissions from a BS transmitter.

The power of any spurious emission shall not exceed the limit specified in table 4.2.4.2.3-1, depending on the declared Base Station class.

Table 4.2.4.2.3-1: BS emissions limits for Spurious protection of the BS receiver

BS class	Frequency range	Maximum Level	Measurement Bandwidth	Exclusions and conditions
Wide Area BS	F_{UL_low} to F_{UL_high}	-96 dBm	100 kHz	
Medium Range BS	F_{UL_low} to F_{UL_high}	-91 dBm	100 kHz	
Local Area BS	F_{UL_low} to F_{UL_high}	-88 dBm	100 kHz	
Home BS	F_{UL_low} to F_{UL_high}	-88 dBm	100 kHz	

NOTE 1: F_{UL_low} and F_{UL_high} are the lowest and highest frequency of the E-UTRA BS uplink operating band respectively.
NOTE 2: For Band 28 BS, this requirement shall only apply in the uplink frequency range where the BS receiver is allowed to operate according to Table 1-1.

4.2.4.2.4 Co-existence with Home BS operating in other bands

These requirements shall be applied for the protection of Home BS receivers operating in other bands. These requirements are only applicable to Home BS.

The power of any spurious emission shall not exceed the limits of table 4.2.4.2.4-1 for a Home BS.

Table 4.2.4.2.4-1: Spurious emissions limits for protection of a Home BS receiver

Protected system	Frequency range	Maximum Level	Measurement Bandwidth	Exclusions and conditions
UTRA FDD band 1, E-UTRA band 1	1 920 MHz to 1 980 MHz	-71 dBm	100 kHz	This requirement shall not apply to Home BS operating in band 1 or 65, since it is already covered by the requirement in clause 4.2.4.2.3.

Protected system	Frequency range	Maximum Level	Measurement Bandwidth	Exclusions and conditions
UTRA FDD band III, E-UTRA band 3	1 710 MHz to 1 785 MHz	-71 dBm	100 kHz	This requirement shall not apply to Home BS operating in band 3, since it is already covered by the requirement in clause 4.2.4.2.3.
UTRA FDD band VII, E-UTRA band 7	2 500 MHz to 2 570 MHz	-71 dBm	100 kHz	This requirement shall not apply to Home BS operating in band 7, since it is already covered by the requirement in clause 4.2.4.2.3.
UTRA FDD band VIII, E-UTRA band 8	880 MHz to 915 MHz	-71 dBm	100 kHz	This requirement shall not apply to Home BS operating in band 8, since it is already covered by the requirement in clause 4.2.4.2.3.
UTRA FDD band XX, E-UTRA band 20	832 MHz to 862 MHz	-71 dBm	100 kHz	This requirement shall not apply to Home BS operating in band 20, since it is already covered by the requirement in clause 4.2.4.2.3.
UTRA FDD band XXII, E-UTRA band 22	3 410 MHz to 3 490 MHz	-71 dBm	100 kHz	This requirement shall not apply to E-UTRA BS operating in band 22, since it is already covered by the requirement in clause 4.2.4.2.3. This requirement shall not apply to E-UTRA BS operating in band 42.
E-UTRA band 28	703 MHz to 748 MHz	-71 dBm	100 kHz	This requirement shall not apply to Home BS operating in band 28, since it is already covered by the requirement in clause 4.2.4.2.3. For E-UTRA BS operating in band 67, it shall apply for 703 MHz to 736 MHz. For E-UTRA BS operating in band 68, it shall apply for 728 MHz to 733 MHz.
UTRA TDD band a) or E-UTRA band 33	1 900 MHz to 1 920 MHz	-71 dBm	100 kHz	This requirement shall not apply to Home BS operating in band 33, since it is already covered by the requirement in clause 4.2.4.2.3.
UTRA TDD band a) or E-UTRA band 34	2 010 MHz to 2 025 MHz	-71 dBm	100 kHz	This requirement shall not apply to Home BS operating in band 34, since it is already covered by the requirement in clause 4.2.4.2.3.
UTRA TDD band d) or E-UTRA band 38	2 570 MHz to 2 620 MHz	-71 dBm	100 kHz	This requirement shall not apply to Home BS operating in band 38, since it is already covered by the requirement in clause 4.2.4.2.3.
UTRA TDD band e) E-UTRA band 40	2 300 MHz to 2 400 MHz	- 71 dBm	100 kHz	This requirement shall not apply to Home BS operating in band 40, since it is already covered by the requirement in clause 4.2.4.2.3.
E-UTRA band 42	3 400 MHz to 3 600 MHz	- 71 dBm	100 kHz	This requirement shall not apply to Home BS operating in band 22, 42 or 43, since it is already covered by the requirement in clause 4.2.4.2.3.
E-UTRA band 43	3 600 MHz to 3 800 MHz	- 71 dBm	100 kHz	This requirement shall not apply to Home BS operating in band 42 or 43, since it is already covered by the requirement in clause 4.2.4.2.3.
E-UTRA band 65	1 920 MHz to 2 010 MHz	-71 dBm	100 kHz	This requirement shall not apply to Home BS operating in band 65, since it is already covered by the requirement in clause 4.2.4.2.3. For Home BS operating in band 1, it shall apply for 1 980 MHz to 2 010 MHz, while the rest is covered in clause 4.2.4.2.3.
E-UTRA band 68	698 MHz to 728 MHz	-71 dBm	100 kHz	This requirement shall not apply to Home BS operating in band 68, since it is already covered by the requirement in clause 4.2.4.2.3. For Home BS operating in band 28, it shall apply between 698 MHz and 703 MHz, while the rest is covered in clause 4.2.4.2.3.

4.2.4.3 Conformance

Conformance tests described in clause 5.3.3 shall be carried out.

4.2.5 Base Station maximum output power

4.2.5.1 Definition

The maximum output power, $P_{\max,c}$ of the Base Station is the mean power level per carrier measured at the antenna connector during the transmitter ON period in a specified reference condition.

For NB-IoT in-band and guard band operation, the E-UTRA carrier and NB-IoT carrier shall be seen as a single carrier occupied E-UTRA channel bandwidth, the output power over this carrier is shared between E-UTRA and NB-IoT. This applies for P_{out} , Rated total output power, $P_{\max,c}$ and $P_{\text{rated,c}}$.

For an E-UTRA BS additionally conforming to ETSI EN 301 908-18 [7], either the requirement of the present clause or the Base Station maximum output power requirement in clause 4.2.5 of ETSI EN 301 908-18 [7] can be equally applied, as listed in table 4.2.1-2.

The requirements in clause 4.2.5 do not apply to operation in band 46.

The output power conditions for E-UTRA BS operation in band 46 are specified in clause 4.2.17.

4.2.5.2 Limit

In normal conditions, the E-UTRA Base Station maximum output power, $P_{\max,c}$, shall remain:

- within +2,7 dB and -2,7 dB of the manufacturer's rated output power $P_{\text{rated,c}}$ for carrier frequency $f \leq 3,0$ GHz;
- within +3,0 dB and -3,0 dB of the manufacturer's rated output power $P_{\text{rated,c}}$ for carrier frequency $3,0 \text{ GHz} < f \leq 4,2 \text{ GHz}$.

In extreme conditions, the E-UTRA Base Station maximum output power, $P_{\max,c}$, shall remain:

- within +3,2 dB and -3,2 dB of the manufacturer's rated output power $P_{\text{rated,c}}$ for carrier frequency $f \leq 3,0$ GHz;
- within +3,5 dB and -3,5 dB of the manufacturer's rated output power $P_{\text{rated,c}}$ for carrier frequency $3,0 \text{ GHz} < f \leq 4,2 \text{ GHz}$.

In normal conditions, for standalone NB-IoT the measurement result in step 2 of 5.3.4.2 shall remain:

- within +3,0 dB and -3,0 dB of the manufacturer's rated output power, $P_{\text{rated,c}}$

In extreme conditions, for standalone NB-IoT measurement result in step 2 of 5.3.4.2 shall remain:

- within +3,5 dB and -3,5 dB of the manufacturer's rated output power, $P_{\text{rated,c}}$.

4.2.5.3 Conformance

Conformance tests described in clause 5.3.4 shall be carried out.

4.2.6 Transmitter intermodulation

4.2.6.1 Definition

The transmitter intermodulation requirement is a measure of the capability of the transmitter to inhibit the generation of signals in its non-linear elements caused by presence of the wanted signal and an interfering signal reaching the transmitter via the antenna. The requirement shall apply during the transmitter ON period and the transmitter transient period.

The transmitter intermodulation level is the power of the intermodulation products when an E-UTRA signal of channel bandwidth 5 MHz as an interfering signal is injected into the antenna connector at a power level of 30 dB less than of the rated total output power in the operating band.

For BS capable of multi-band operation where multiple bands are mapped on separate antenna connectors, the single-band requirements apply regardless of the interfering signals position relative to the Inter RF Bandwidth gap.

The wanted signal is E-UTRA single carrier, or multi-carrier, or multiple contiguously aggregated carriers, for both contiguous and non-contiguous spectrum operation.

The requirements shall apply whatever the type of transmitter considered (single carrier or multi-carrier) and for all transmission modes foreseen by the manufacturer's specification.

For an E-UTRA BS additionally conforming to ETSI EN 301 908-18 [7], either the requirement of the present clause or the Transmitter intermodulation requirement in clause 4.2.6 of ETSI EN 301 908-18 [7] can be equally applied, as listed in table 4.2.1-2.

4.2.6.2 Limit

The wanted signal channel bandwidth BW_{Channel} shall be the maximum channel bandwidth supported by the Base Station.

In the frequency range relevant for this test, the transmit intermodulation level shall not exceed the unwanted emission requirements of clauses 4.2.2.2, 4.2.3.4 and 4.2.4.2 in the presence of an interfering signal according to table 4.2.6.2-1.

For a BS operating in non-contiguous spectrum, the requirement is shall also apply inside a sub-block gap for interfering signal offsets where the interfering signal falls completely within the sub-block gap. The interfering signal offset is defined relative to the sub-block edges.

For a BS capable of multi-band operation, the requirement shall apply relative to the Base Station RF Bandwidth edges of each supported operating band. In case the Inter RF Bandwidth gap is less than 15 MHz, the requirement in the gap applies only for interfering signal offsets where the interfering signal falls completely within the Inter RF Bandwidth gap.

The requirement is applicable outside the Base Station RF Bandwidth or Maximum Radio Bandwidth. The interfering signal offset is defined relative to the Base Station RF Bandwidth edges or Maximum Radio Bandwidth edges.

Table 4.2.6.2-1: Interfering and wanted signals for the Transmitter intermodulation requirement

Parameter	Value
Interfering signal centre frequency offset from the lower/upper edge of the wanted signal or sub-block edge inside a sub-block gap.	$\pm 2,5$ MHz $\pm 7,5$ MHz $\pm 12,5$ MHz
NOTE: Interfering signal positions that are partially or completely outside of the downlink operating band of the Base Station are excluded from the requirement, unless the interfering signal positions fall within the frequency range of adjacent downlink operating bands listed in table 1-1.	

In case that none of the interfering signal positions according to the conditions of table 4.2.6.2-1 is applicable, a wanted signal channel bandwidth BW_{Channel} less than the maximum channel bandwidth supported by the Base Station shall be selected so that at least one applicable interfering signal position according to table 4.2.6.2-1 is obtained.

The measurements for unwanted emission requirement due to intermodulation can be limited to the frequency ranges of all third and fifth order intermodulation products, considering the width of these products and excluding the bandwidths of the wanted and interfering signals.

4.2.6.3 Conformance

Conformance tests described in clause 5.3.5 shall be carried out.

4.2.7 Receiver spurious emissions

4.2.7.1 Definition

The spurious emissions power is the power of emissions generated or amplified in a receiver that appear at the BS receiver antenna connector. The requirements apply to all BS with separate RX and TX antenna ports. The test shall be performed when both TX and RX are on, with the TX port terminated.

For TDD BS with common RX and TX antenna port the requirement shall apply during the Transmitter OFF period. For FDD BS with common RX and TX antenna port the transmitter spurious emission limits as, specified in clause 4.2.4, apply.

For BS capable of multi-band operation where multiple bands are mapped on separate antenna connectors, the single-band requirements apply and the excluded frequency range is only applicable for the operating band supported on each antenna connector.

Unless otherwise stated, a BS declared to be capable of E-UTRA with NB-IoT in-band and guard band operations is only required to pass the receiver spurious emissions tests for E-UTRA with guard band operation. It is not required to perform the receiver spurious emissions tests again for E-UTRA with in-band operation.

For an E-UTRA BS additionally conforming to ETSI EN 301 908-18 [7], either the requirement of the present clause or the Receiver spurious emissions requirement in clause 4.2.7 of ETSI EN 301 908-18 [7] can be equally applied, as listed in table 4.2.1-2.

4.2.7.2 Limit

The power of any spurious emission shall not exceed the levels in table 4.2.7.2-1.

In addition to the requirements in table 4.2.7.2-1, the power of any spurious emission shall not exceed the limits specified in clauses 4.2.4.2.2 and 4.2.4.2.3.

Table 4.2.7.2-1: General spurious emission test requirement

Frequency range	Maximum level	Measurement Bandwidth	Exclusions and conditions
30 MHz to 1 GHz	-57 dBm	100 kHz	
1 GHz to 12,75 GHz	-47 dBm	1 MHz	
12,75 GHz to 5 th harmonic of the upper frequency edge of the downlink operating band	-47 dBm	1 MHz	Shall apply only for bands 22, 42 and 43.
NOTE: The frequency range between $2,5 \times BW_{\text{Channel}}$ below the first carrier frequency and $2,5 \times BW_{\text{Channel}}$ above the last carrier frequency transmitted by the BS, where BW_{Channel} is the channel bandwidth according to ETSI TS 136 141 [1], table 5.6-1, may be excluded from the requirement. However, frequencies that are more than 10 MHz below the lowest frequency of any of the supported downlink operating band or more than 10 MHz above the highest frequency of any of the supported downlink operating band (see table 1-1) shall not be excluded from the requirement. For BS capable of multi-band operation, the excluded frequency range applies for all supported operating bands. For BS capable of multi-band operation where multiple bands are mapped on separate antenna connectors, the single-band requirements apply and the excluded frequency range is only applicable for the operating band supported on each antenna connector.			

4.2.7.3 Conformance

Conformance tests described in clause 5.3.6 shall be carried out.

4.2.8 Blocking characteristics

4.2.8.1 Definition

The blocking characteristics is a measure of the receiver ability to receive a wanted signal at its assigned channel in the presence of an unwanted interferer, which are either a 1,4 MHz, 3 MHz or 5 MHz E-UTRA signal for in-band blocking or a CW signal for out-of-band blocking. The interfering E-UTRA signal shall be as specified in ETSI TS 136 141 [1], annex C.

Unless otherwise stated, a BS declared to be capable of E-UTRA with NB-IoT in-band and guard band operations is only required to pass the blocking receiver tests for E-UTRA with guard band operation. It is not required to perform the blocking receiver tests again for E-UTRA with in-band operation.

For an E-UTRA BS additionally conforming to ETSI EN 301 908-18 [7], either the requirement of the present clause or the In-band and Out-of-band blocking requirements in clauses 4.2.8 and 4.2.9 of ETSI EN 301 908-18 [7] can be equally applied, as listed in table 4.2.1-2.

4.2.8.2 Limit

For each measured E-UTRA carrier, the throughput shall be ≥ 95 % of the maximum throughput of the reference measurement channel, with a wanted and an interfering signal coupled to BS antenna input using the parameters in table 4.2.8.2-4 and tables 4.2.8.2-1 to 4.2.8.2-3 or 4.2.8.2-5, depending on the declared Base Station class and operating band. The reference measurement channel for the wanted signal is for each channel bandwidth specified in tables 4.2.14.2-1 to 4.2.14.2-4.

For each measured NB-IoT carrier, the throughput shall be ≥ 95 % of the maximum throughput of the reference measurement channel, with a wanted and an interfering signal coupled to BS antenna input using the parameters in tables 4.2.8.2-6 to 4.2.8.2-9. The reference measurement channel for the wanted signal is specified in table 4.2.14.2-5 for each subcarrier spacing option.

The blocking requirement is applicable outside the Base Station RF Bandwidth or Maximum Radio Bandwidth. The interfering signal offset is defined relative to the Base Station RF Bandwidth edges or Maximum Radio Bandwidth edges.

For a BS operating in non-contiguous spectrum within any operating band, the blocking requirement shall apply in addition inside any sub-block gap, in case the sub-block gap size is at least as wide as twice the interfering signal minimum offset in table 4.2.8.2-4. The interfering signal offset is defined relative to the sub-block edges inside the sub-block gap.

For a BS capable of multi-band operation, the requirement in the in-band blocking frequency ranges shall apply for each supported operating band. The requirement shall apply in addition inside any Inter RF Bandwidth gap, in case the Inter RF Bandwidth gap size is at least as wide as twice the interfering signal minimum offset in table 4.2.8.2-4.

For a BS capable of multi-band operation, the requirement in the out-of-band blocking frequency ranges shall apply for each operating band, with the exception that the in-band blocking frequency ranges of all supported operating bands according to tables 4.2.8.2-1, 4.2.8.2-2 and 4.2.8.2-5, shall be excluded from the out-of-band blocking requirement.

Table 4.2.8.2-1: Blocking performance requirement for Wide Area BS

Operating band	Centre Frequency of Interfering Signal (MHz) (note 1)	Interfering Signal mean power (dBm)	Wanted Signal mean power (dBm) (note 2)	Interfering signal centre frequency minimum frequency offset from the lower/upper Base Station RF Bandwidth edge or sub-block edge inside a sub-block gap (MHz)	Type of Interfering Signal
1, 3, 7, 22, 32-34, 38, 40, 42, 43, 65, 68	$(F_{UL_low} - 20)$ to $(F_{UL_high} + 20)$	-43	$P_{REFSENS} + 6$ dB (note 3)	See table 4.2.8.2-4	See table 4.2.8.2-4
	1 to $(F_{UL_low} - 20)$ $(F_{UL_high} + 20)$ to 12 750	-15	$P_{REFSENS} + 6$ dB	-	CW carrier

Operating band	Centre Frequency of Interfering Signal (MHz) (note 1)	Interfering Signal mean power (dBm)	Wanted Signal mean power (dBm) (note 2)	Interfering signal centre frequency minimum frequency offset from the lower/upper Base Station RF Bandwidth edge or sub-block edge inside a sub-block gap (MHz)	Type of Interfering Signal
8, 28	$(F_{UL_low} - 20)$ to $(F_{UL_high} + 10)$	-43	$P_{REFSENS} + 6$ dB (note 3)	See table 4.2.8.2-4	See table 4.2.8.2-4
	1 to $(F_{UL_low} - 20)$ $(F_{UL_high} + 10)$ to 12 750	-15	$P_{REFSENS} + 6$ dB	-	CW carrier
20	$(F_{UL_low} - 11)$ to $(F_{UL_high} + 20)$	-43	$P_{REFSENS} + 6$ dB (note 3)	See table 4.2.8.2-4	See table 4.2.8.2-4
	1 to $(F_{UL_low} - 11)$ $(F_{UL_high} + 20)$ to 12 750	-15	$P_{REFSENS} + 6$ dB	-	CW carrier
31	$(F_{UL_low} - 20)$ to $(F_{UL_high} + 5)$	-43	$P_{REFSENS} + 6$ dB	See table 4.2.8.2-4	See table 4.2.8.2-4
	1 to $(F_{UL_low} - 20)$ $(F_{UL_high} + 5)$ to 12 750	-15	$P_{REFSENS} + 6$ dB	—	CW carrier

NOTE 1: F_{UL_low} and F_{UL_high} are the lowest and highest frequencies of the uplink operating band, as defined in table 1-1.

NOTE 2: $P_{REFSENS}$ depends on the channel bandwidth as specified in clause 4.2.14.2.

NOTE 3: For a BS capable of multiband operation, in case of interfering signal that is not in the in-band blocking frequency range of the operating band where the wanted signal is present, and not in an adjacent or overlapping band, the wanted signal mean power is equal to $P_{REFSENS} + 1,4$ dB.

Table 4.2.8.2-2: Blocking performance requirement for Local Area BS

Operating band	Centre Frequency of Interfering Signal (MHz) (note 1)	Interfering Signal mean power (dBm)	Wanted Signal mean power (dBm) (note 2)	Interfering signal centre frequency minimum frequency offset from the lower/upper Base Station RF Bandwidth edge or sub-block edge inside a sub-block gap (MHz)	Type of Interfering Signal
1, 3, 7, 22, 32-34, 38, 40, 42, 43, 65, 68	$(F_{UL_low} - 20)$ to $(F_{UL_high} + 20)$	-35	$P_{REFSENS} + 6$ dB (note 3)	See table 4.2.8.2-4	See table 4.2.8.2-4
	1 to $(F_{UL_low} - 20)$ $(F_{UL_high} + 20)$ to 12 750	-15	$P_{REFSENS} + 6$ dB	-	CW carrier
8, 28	$(F_{UL_low} - 20)$ to $(F_{UL_high} + 10)$	-35	$P_{REFSENS} + 6$ dB (note 3)	See table 4.2.8.2-4	See table 4.2.8.2-4
	1 to $(F_{UL_low} - 20)$ $(F_{UL_high} + 10)$ to 12 750	-15	$P_{REFSENS} + 6$ dB	-	CW carrier

Operating band	Centre Frequency of Interfering Signal (MHz) (note 1)	Interfering Signal mean power (dBm)	Wanted Signal mean power (dBm) (note 2)	Interfering signal centre frequency minimum frequency offset from the lower/upper Base Station RF Bandwidth edge or sub-block edge inside a sub-block gap (MHz)	Type of Interfering Signal
20	$(F_{UL_low} - 11)$ to $(F_{UL_high} + 20)$	-35	$P_{REFSENS} + 6$ dB (note 3)	See table 4.2.8.2-4	See table 4.2.8.2-4
	1 to $(F_{UL_low} - 11)$ $(F_{UL_high} + 20)$ to 12 750	-15	$P_{REFSENS} + 6$ dB	-	CW carrier
31	$(F_{UL_low} - 20)$ to $(F_{UL_high} + 5)$	-35	$P_{REFSENS} + 6$ dB	See table 4.2.8.2-4	See table 4.2.8.2-4
	1 to $(F_{UL_low} - 20)$ $(F_{UL_high} + 5)$ to 12 750	-15	$P_{REFSENS} + 6$ dB	—	CW carrier

NOTE 1: F_{UL_low} and F_{UL_high} are the lowest and highest frequencies of the uplink operating band, as defined in table 1-1.

NOTE 2: $P_{REFSENS}$ depends on the channel bandwidth as specified in clause 4.2.14.2.

NOTE 3: For a BS capable of multiband operation, in case of interfering signal that is not in the in-band blocking frequency range of the operating band where the wanted signal is present, and not in an adjacent or overlapping band, the wanted signal mean power is equal to $P_{REFSENS} + 1,4$ dB.

Table 4.2.8.2-3: Blocking performance requirement for Home BS

Operating band	Centre Frequency of Interfering Signal (MHz) (note 1)	Interfering Signal mean power (dBm)	Wanted Signal mean power (dBm) (note 2)	Interfering signal centre frequency minimum frequency offset from the channel edge of the wanted signal (MHz)	Type of Interfering Signal
1, 3, 7, 22, 32-34, 38, 40, 42, 43, 65, 68	$(F_{UL_low} - 20)$ to $(F_{UL_high} + 20)$	-27	$P_{REFSENS} + 14$ dB	See table 4.2.8.2-4	See table 4.2.8.2-4
	1 to $(F_{UL_low} - 20)$ $(F_{UL_high} + 20)$ to 12 750	-15	$P_{REFSENS} + 14$ dB	-	CW carrier
8, 28	$(F_{UL_low} - 20)$ to $(F_{UL_high} + 10)$	-27	$P_{REFSENS} + 14$ dB	See table 4.2.8.2-4	See table 4.2.8.2-4
	1 to $(F_{UL_low} - 20)$ $(F_{UL_high} + 10)$ to 12 750	-15	$P_{REFSENS} + 14$ dB	-	CW carrier
20	$(F_{UL_low} - 11)$ to $(F_{UL_high} + 20)$	-27	$P_{REFSENS} + 14$ dB	See table 4.2.8.2-4	See table 4.2.8.2-4
	1 to $(F_{UL_low} - 11)$ $(F_{UL_high} + 20)$ to 12 750	-15	$P_{REFSENS} + 14$ dB	-	CW carrier

NOTE 1: F_{UL_low} and F_{UL_high} are the lowest and highest frequencies of the uplink operating band, as defined in table 1-1.

NOTE 2: $P_{REFSENS}$ depends on the channel bandwidth as specified in clause 4.2.14.2.

Table 4.2.8.2-4: Interfering signals for Blocking performance requirement

E-UTRA channel BW of the lowest/highest carrier received (MHz)	Interfering signal centre frequency minimum offset to the lower/upper Base Station RF Bandwidth edge or sub-block edge inside a sub-block gap (MHz)	Type of interfering signal
1,4	±2,1	1,4 MHz E-UTRA signal
3	±4,5	3 MHz E-UTRA signal
5	±7,5	5 MHz E-UTRA signal
10	±7,5	5 MHz E-UTRA signal
15	±7,5	5 MHz E-UTRA signal
20	±7,5	5 MHz E-UTRA signal

Table 4.2.8.2-5: Blocking performance requirement for Medium Range BS

Operating band	Centre Frequency of Interfering Signal (MHz) (note 1)	Interfering Signal mean power (dBm)	Wanted Signal mean power (dBm) (note 2)	Interfering signal centre frequency minimum frequency offset from the lower/upper Base Station RF Bandwidth edge or sub-block edge inside a sub-block gap (MHz)	Type of Interfering Signal
1, 3, 7, 22, 32-34, 38, 40, 42, 43, 65, 68	$(F_{UL_low} - 20)$ to $(F_{UL_high} + 20)$	-38	$P_{REFSENS} + 6$ dB (note 3)	See table 4.2.8.2-4	See table 4.2.8.2-4
	$(F_{UL_high} + 20)$ to $(F_{UL_low} - 20)$ to 12 750	-15	$P_{REFSENS} + 6$ dB	-	CW carrier
8, 28	$(F_{UL_low} - 20)$ to $(F_{UL_high} + 10)$	-38	$P_{REFSENS} + 6$ dB (note 3)	See table 4.2.8.2-4	See table 4.2.8.2-4
	$(F_{UL_high} + 10)$ to $(F_{UL_low} - 20)$ to 12 750	-15	$P_{REFSENS} + 6$ dB	-	CW carrier
20	$(F_{UL_low} - 11)$ to $(F_{UL_high} + 20)$	-38	$P_{REFSENS} + 6$ dB (note 3)	See table 4.2.8.2-4	See table 4.2.8.2-4
	$(F_{UL_high} + 20)$ to $(F_{UL_low} - 11)$ to 12 750	-15	$P_{REFSENS} + 6$ dB	-	CW carrier
31	$(F_{UL_low} - 20)$ to $(F_{UL_high} + 5)$	-38	$P_{REFSENS} + 6$ dB	See table 4.2.8.2-4	See table 4.2.8.2-4
	$(F_{UL_high} + 5)$ to $(F_{UL_low} - 20)$ to 12 750	-15	$P_{REFSENS} + 6$ dB	—	CW carrier
NOTE 1: F_{UL_low} and F_{UL_high} are the lowest and highest frequencies of the uplink operating band, as defined in table 1-1.					
NOTE 2: $P_{REFSENS}$ depends on the channel bandwidth as specified in clause 4.2.14.2.					
NOTE 3: For a BS capable of multiband operation, in case of interfering signal that is not in the in-band blocking frequency range of the operating band where the wanted signal is present, and not in an adjacent or overlapping band, the wanted signal mean power is equal to $P_{REFSENS} + 1,4$ dB.					

Table 4.2.8.2-6: Blocking performance requirement for Wide Area BS for NB-IoT standalone operation

Operating Band	Centre Frequency of Interfering Signal [MHz]	Interfering Signal mean power [dBm]	Wanted Signal mean power [dBm]	Interfering signal centre frequency minimum frequency offset from the lower/upper Base Station RF Bandwidth edge or sub-block edge inside a sub-block gap [MHz]	Type of Interfering Signal
1, 3,	$(F_{UL_low} - 20)$ to $(F_{UL_high} + 20)$	-43	$P_{REFSENS} + 6$ dB (note 1)	See table 4.2.8.2-8	See table 4.2.8.2-8
	1 to $(F_{UL_low} - 20)$ $(F_{UL_high} + 20)$ to 12 750	-15 (note 2)	$P_{REFSENS} + 6$ dB (note 1)	-	CW carrier
8, 28	$(F_{UL_low} - 20)$ to $(F_{UL_high} + 10)$	-43	$P_{REFSENS} + 6$ dB (note 1)	See table 4.2.8.2-8	See table 4.2.8.2-8
	1 to $(F_{UL_low} - 20)$ $(F_{UL_high} + 10)$ to 12 750	-15 (note 2)	$P_{REFSENS} + 6$ dB (note 1)	-	CW carrier
20	$(F_{UL_low} - 11)$ to $(F_{UL_high} + 20)$	-43	$P_{REFSENS} + 6$ dB (note 1)	See table 4.2.8.2-8	See table 4.2.8.2-8
	1 to $(F_{UL_low} - 11)$ $(F_{UL_high} + 20)$ to 12 750	-15 (note 2)	$P_{REFSENS} + 6$ dB (note 1)	-	CW carrier

NOTE 1: $P_{REFSENS}$ is specified in clause 4.2.14.2.

NOTE 2: Up to 24 exceptions are allowed for spurious response frequencies in each wanted signal frequency when measured using a 1 MHz step size. For these exceptions the above throughput requirement shall be met when the blocking signal is set to a level of -40 dBm for 15 kHz subcarrier spacing and -46 dBm for 3,75 kHz subcarrier spacing. In addition, each group of exceptions shall not exceed three contiguous measurements using a 1 MHz step size.

Table 4.2.8.2-7: Blocking performance requirement for Wide Area BS for E-UTRA with NB-IoT in-band/guard band operation

Operating Band	Centre Frequency of Interfering Signal [MHz]	Interfering Signal mean power [dBm]	Wanted Signal mean power [dBm]	Interfering signal centre frequency minimum frequency offset from the lower/upper Base Station RF Bandwidth edge or sub-block edge inside a sub-block gap [MHz]	Type of Interfering Signal
1, 3	$(F_{UL_low} - 20)$ to $(F_{UL_high} + 20)$	-43	$P_{REFSENS} + 6$ dB (note 1)	See table 4.2.8.2-9	See table 4.2.8.2-9
	1 to $(F_{UL_low} - 20)$ $(F_{UL_high} + 20)$ to 12 750	-15 (note 3)	$P_{REFSENS} + 6$ dB (note 1)	-	CW carrier
8, 28	$(F_{UL_low} - 20)$ to $(F_{UL_high} + 10)$	-43	$P_{REFSENS} + 6$ dB (note 1)	See table 4.2.8.2-9	See table 4.2.8.2-9
	1 to $(F_{UL_low} - 20)$ $(F_{UL_high} + 10)$ to 12 750	-15 (note 3)	$P_{REFSENS} + 6$ dB (note 1)	-	CW carrier
20	$(F_{UL_low} - 11)$ to $(F_{UL_high} + 20)$	-43	$P_{REFSENS} + 6$ dB (note 1)	See table 4.2.8.2-9	See table 4.2.8.2-9
	1 to $(F_{UL_low} - 11)$ $(F_{UL_high} + 20)$ to 12 750	-15 (note 3)	$P_{REFSENS} + 6$ dB (note 1)	-	CW carrier

NOTE 1: $P_{REFSENS}$ depends on the channel bandwidth or supported subcarrier spacing as specified in clause 4.2.14.2.
NOTE 2: For a BS capable of multiband operation, in case of interfering signal that is not in the in-band blocking frequency range of the operating band where the wanted signal is present, the wanted signal mean power is equal to $P_{REFSENS} + 1,4$ dB.
NOTE 3: For NB-IoT, up to 24 exceptions are allowed for spurious response frequencies in each wanted signal frequency when measured using a 1 MHz step size. For these exceptions the above throughput requirement shall be met when the blocking signal is set to a level of -40 dBm for 15 kHz subcarrier spacing and -46 dBm for 3,75 kHz subcarrier spacing. In addition, each group of exceptions shall not exceed three contiguous measurements using a 1 MHz step size.

Table 4.2.8.2-8: Interfering signals for blocking performance requirement for NB-IoT standalone operation

NB-IoT channel BW of the lowest/highest carrier received [MHz]	Interfering signal centre frequency minimum offset to the lower/upper Base Station RF Bandwidth edge or sub-block edge inside a sub-block gap [MHz]	Type of interfering signal
0,2	$\pm 7,5$	5 MHz E-UTRA signal

Table 4.2.8.2-9: Interfering signals for blocking performance requirement for E-UTRA with NB-IoT in-band/guard band operation

E-UTRA channel BW of the lowest/highest carrier received [MHz]	Interfering signal centre frequency minimum offset to the lower/upper Base Station RF Bandwidth edge or sub-block edge inside a sub-block gap [MHz]	Type of interfering signal
3 (note)	$\pm 4,5$	3 MHz E-UTRA signal
5	$\pm 7,5$	5 MHz E-UTRA signal
10	$\pm 7,5$	5 MHz E-UTRA signal
15	$\pm 7,5$	5 MHz E-UTRA signal
20	$\pm 7,5$	5 MHz E-UTRA signal

NOTE: 3 MHz channel bandwidth is not applicable to guard band operation.

4.2.8.3 Conformance

Conformance tests described in clause 5.3.7 shall be carried out.

4.2.9 Receiver intermodulation characteristics

4.2.9.1 Definition

Third and higher order mixing of the two interfering RF signals can produce an interfering signal in the band of the desired channel. Intermodulation response rejection is a measure of the capability of the receiver to receive a wanted signal on its assigned channel frequency in the presence of two interfering signals which have a specific frequency relationship to the wanted signal. Interfering signals shall be a CW signal and an E-UTRA signal as specified in ETSI TS 136 141 [1], annex C.

Unless otherwise stated, a BS declared to be capable of E-UTRA with NB-IoT in-band and guard band operations is only required to pass the receiver intermodulation tests for E-UTRA with guard band operation. It is not required to perform the receiver intermodulation tests again for E-UTRA with in-band operation.

For an E-UTRA BS additionally conforming to ETSI EN 301 908-18 [7], either the requirement of the present clause or the Receiver intermodulation requirement in clause 4.2.10 of ETSI EN 301 908-18 [7] can be equally applied, as listed in table 4.2.1-2.

4.2.9.2 Limit

The throughput for each E-UTRA carrier shall be ≥ 95 % of the maximum throughput of the reference measurement channel, with a wanted signal at the assigned channel frequency and two interfering signals with the conditions specified in tables 4.2.9.2-1 and 4.2.9.2-2 for intermodulation performance and in tables 4.2.9.2-3 to 4.2.9.2-5 or 4.2.9.2-6 depending on the declared Base Station class for narrowband intermodulation performance. The reference measurement channel for the wanted signal is specified in tables 4.2.14.2-1 to 4.2.14.2-4 for each channel bandwidth and further specified in annex A of ETSI TS 136 141 [1].

For each measured NB-IoT carrier, the throughput shall be ≥ 95 % of the maximum throughput of the reference measurement channel, with a wanted signal at the assigned channel frequency and two interfering signals with the conditions specified in tables 4.2.9.2-2 and 4.2.9.2-7 to 4.2.9.2-10 for intermodulation performance, and in tables 4.2.9.2-11 to 4.2.9.2-13 for narrowband intermodulation performance. The reference measurement channel for the wanted signal is specified in table 4.2.14.2-5 for each channel sub-carrier spacing option.

The receiver intermodulation requirement is always applicable outside the Base Station RF Bandwidth or Maximum Radio Bandwidth. The interfering signal offset is defined relative to the Base Station RF Bandwidth edges or Maximum Radio Bandwidth edges.

For a BS operating in non-contiguous spectrum within any operating band, the narrowband intermodulation requirement shall apply in addition inside any sub-block gap in case the sub-block gap is at least as wide as the channel bandwidth of the E-UTRA interfering signal in table 4.2.9.2-2. The interfering signal offset is defined relative to the sub-block edges inside the sub-block gap. The requirement shall apply separately for both sub-blocks.

For a BS capable of multi-band operation, the intermodulation requirement shall apply in addition inside any Inter RF Bandwidth gap, in case the gap size is at least twice as wide as the E-UTRA interfering signal centre frequency offset from the Base Station RF Bandwidth edge.

For a BS capable of multi-band operation, the narrowband intermodulation requirement shall apply in addition inside any Inter RF Bandwidth gap in case the gap size is at least as wide as the E-UTRA interfering signal in tables 4.2.9.2-3, 4.2.9.2-4 or 4.2.9.2-6. The interfering signal offset is defined relative to the Base Station RF Bandwidth edges inside the Inter RF Bandwidth gap.

Table 4.2.9.2-1: Intermodulation performance requirement for E-UTRA

BS class	Wanted signal mean power (dBm)	Interfering signal mean power	Type of interfering signal
Wide area BS	$P_{\text{REFSENS}} + 6 \text{ dB}$ (note)	-52 dBm	See table 4.2.9.2-2
Medium Range BS	$P_{\text{REFSENS}} + 6 \text{ dB}$ (note)	-47 dBm	
Local Area BS	$P_{\text{REFSENS}} + 6 \text{ dB}$ (note)	-44 dBm	
Home BS	$P_{\text{REFSENS}} + 14 \text{ dB}$ (note)	-36 dBm	

NOTE: P_{REFSENS} depends on the channel bandwidth as specified in clause 4.2.14.2.
For E-UTRA channel bandwidths 10 MHz, 15 MHz and 20 MHz this requirement shall apply only for a FRC A1-3 (see ETSI TS 136 141 [1], clause A.1) mapped to the frequency range at the channel edge adjacent to the interfering signals.

Table 4.2.9.2-2: Interfering signal for Intermodulation performance requirement for E-UTRA or E-UTRA with NB-IoT in-band/guard band operation BS

E-UTRA channel bandwidth of the lowest/highest carrier received (MHz)	Interfering signal centre frequency offset from the lower/upper Base Station RF Bandwidth edge (MHz)	Type of interfering signal
3 (note)	$\pm 4,5$	CW
	$\pm 10,5$	3 MHz E-UTRA signal
5	$\pm 7,5$	CW
	$\pm 17,5$	5 MHz E-UTRA signal
10	$\pm 7,375$	CW
	$\pm 17,5$	5 MHz E-UTRA signal
15	$\pm 7,25$	CW
	$\pm 17,5$	5 MHz E-UTRA signal
20	$\pm 7,125$	CW
	$\pm 17,5$	5 MHz E-UTRA signal

NOTE: 3 MHz channel bandwidth is not applicable to guard band operation.

Table 4.2.9.2-3: Narrowband intermodulation performance requirement for Wide Area BS for E-UTRA

E-UTRA channel bandwidth of the lowest/highest carrier received (MHz)	Wanted signal mean power (dBm)	Interfering signal mean power (dBm)	Interfering RB centre frequency offset from the lower/upper Base Station RF Bandwidth edge or sub-block edge inside a sub-block gap (kHz)	Type of interfering signal
1,4	$P_{\text{REFSENS}} + 6 \text{ dB}$ (note 1)	-52	± 270	CW
		-52	± 790	1,4 MHz E-UTRA signal, 1 RB (note 2)
3	$P_{\text{REFSENS}} + 6 \text{ dB}$ (note 1)	-52	± 270	CW
		-52	± 780	3 MHz E-UTRA signal, 1 RB (note 2)
5	$P_{\text{REFSENS}} + 6 \text{ dB}$ (note 1)	-52	± 360	CW
		-52	$\pm 1\ 060$	5 MHz E-UTRA signal, 1 RB (note 2)
10	$P_{\text{REFSENS}} + 6 \text{ dB}$ (notes 1 and 3)	-52	± 325	CW
		-52	$\pm 1\ 240$	5 MHz E-UTRA signal, 1 RB (note 2)

E-UTRA channel bandwidth of the lowest/highest carrier received (MHz)	Wanted signal mean power (dBm)	Interfering signal mean power (dBm)	Interfering RB centre frequency offset from the lower/upper Base Station RF Bandwidth edge or sub-block edge inside a sub-block gap (kHz)	Type of interfering signal
15	$P_{\text{REFSENS}} + 6 \text{ dB}$ (notes 1 and 3)	-52	± 380	CW
		-52	$\pm 1\ 600$	5 MHz E-UTRA signal, 1 RB (note 2)
20	$P_{\text{REFSENS}} + 6 \text{ dB}$ (notes 1 and 3)	-52	± 345	CW
		-52	$\pm 1\ 780$	5 MHz E-UTRA signal, 1 RB (note 2)

NOTE 1: P_{REFSENS} is related to the channel bandwidth as specified in clause 4.2.14.2.

NOTE 2: Interfering signal consisting of one resource block positioned at the stated offset, the channel bandwidth of the interfering signal is located adjacently to the channel bandwidth of the lower/upper Base Station RF Bandwidth edge.

NOTE 3: This requirement shall apply only for an FRC A1-3 (see ETSI TS 136 141 [1], clause A.1) mapped to the frequency range at the channel edge adjacent to the interfering signals.

Table 4.2.9.2-4: Narrowband intermodulation performance requirement for Local Area BS for E-UTRA

E-UTRA channel bandwidth of the lowest/ highest carrier received (MHz)	Wanted signal mean power (dBm)	Interfering signal mean power (dBm)	Interfering RB centre frequency offset from the lower/upper Base Station RF Bandwidth edge or sub-block edge inside a sub-block (kHz)	Type of interfering signal
1,4	$P_{\text{REFSENS}} + 6 \text{ dB}$ (note 1)	-44	± 270	CW
		-44	± 790	1,4 MHz E-UTRA signal, 1 RB (note 2)
3	$P_{\text{REFSENS}} + 6 \text{ dB}$ (note 1)	-44	± 270	CW
		-44	± 780	3 MHz E-UTRA signal, 1 RB (note 2)
5	$P_{\text{REFSENS}} + 6 \text{ dB}$ (note 1)	-44	± 360	CW
		-44	$\pm 1\ 060$	5 MHz E-UTRA signal, 1 RB (note 2)
10	$P_{\text{REFSENS}} + 6 \text{ dB}$ (notes 1 and 3)	-44	± 325	CW
		-44	$\pm 1\ 240$	5 MHz E-UTRA signal, 1 RB (note 2)
15	$P_{\text{REFSENS}} + 6 \text{ dB}$ (notes 1 and 3)	-44	± 380	CW
		-44	$\pm 1\ 600$	5 MHz E-UTRA signal, 1 RB (note 2)
20	$P_{\text{REFSENS}} + 6 \text{ dB}$ (notes 1 and 3)	-44	± 345	CW
		-44	$\pm 1\ 780$	5 MHz E-UTRA signal, 1 RB (note 2)

NOTE 1: P_{REFSENS} is related to the channel bandwidth as specified in clause 4.2.14.2.

NOTE 2: Interfering signal consisting of one resource block positioned at the stated offset, the channel bandwidth of the interfering signal is located adjacently to the lower/upper Base Station RF Bandwidth edge.

NOTE 3: This requirement shall apply only for an FRC A1-3 (ETSI TS 136 141 [1], clause A.1) mapped to the frequency range at the channel edge adjacent to the interfering signals.

Table 4.2.9.2-5: Narrowband intermodulation performance requirement for Home BS for E-UTRA

E-UTRA channel bandwidth (MHz)	Wanted signal mean power (dBm)	Interfering signal mean power (dBm)	Interfering RB centre frequency offset from the channel edge of the wanted signal (kHz)	Type of interfering signal
1,4	$P_{\text{REFSENS}} + 14$ dB (note 1)	-36	270	CW
		-36	790	1,4 MHz E-UTRA signal, 1 RB (note 2)
3	$P_{\text{REFSENS}} + 14$ dB (note 1)	-36	270	CW
		-36	780	3 MHz E-UTRA signal, 1 RB (note 2)
5	$P_{\text{REFSENS}} + 14$ dB (note 1)	-36	360	CW
		-36	1 060	5 MHz E-UTRA signal, 1 RB (note 2)
10	$P_{\text{REFSENS}} + 14$ dB (notes 1 and 3)	-36	325	CW
		-36	1 240	5 MHz E-UTRA signal, 1 RB (note 2)
15	$P_{\text{REFSENS}} + 14$ dB (notes 1 and 3)	-36	380	CW
		-36	1 600	5 MHz E-UTRA signal, 1 RB (note 2)
20	$P_{\text{REFSENS}} + 14$ dB (notes 1 and 3)	-36	345	CW
		-36	1 780	5 MHz E-UTRA signal, 1 RB (note 2)

NOTE 1: P_{REFSENS} is related to the channel bandwidth as specified in clause 4.2.14.2.

NOTE 2: Interfering signal consisting of one resource block positioned at the stated offset, the channel bandwidth of the interfering signal is located adjacently to the channel edge of the wanted signal.

NOTE 3: This requirement shall apply only for an FRC A1-3 (ETSI TS 136 141 [1], clause A.1) mapped to the frequency range at the channel edge adjacent to the interfering signals.

Table 4.2.9.2-6: Narrowband intermodulation performance requirement for Medium Range BS for E-UTRA

E-UTRA channel bandwidth of the lowest/highest carrier received (MHz)	Wanted signal mean power (dBm)	Interfering signal mean power (dBm)	Interfering RB centre frequency offset from the lower/upper Base Station RF Bandwidth edge or sub-block edge inside a sub-block (kHz)	Type of interfering signal
1,4	$P_{\text{REFSENS}} + 6$ dB (note 1)	-47	± 270	CW
		-47	± 790	1,4 MHz E-UTRA signal, 1 RB (note 2)
3	$P_{\text{REFSENS}} + 6$ dB (note 1)	-47	± 270	CW
		-47	± 780	3 MHz E-UTRA signal, 1 RB (note 2)
5	$P_{\text{REFSENS}} + 6$ dB (note 1)	-47	± 360	CW
		-47	$\pm 1\ 060$	5 MHz E-UTRA signal, 1 RB (note 2)
10	$P_{\text{REFSENS}} + 6$ dB (notes 1 and 3)	-47	± 325	CW
		-47	$\pm 1\ 240$	5 MHz E-UTRA signal, 1 RB (note 2)
15	$P_{\text{REFSENS}} + 6$ dB (notes 1 and 3)	-47	± 380	CW
		-47	$\pm 1\ 600$	5 MHz E-UTRA signal, 1 RB (note 2)
20	$P_{\text{REFSENS}} + 6$ dB (notes 1 and 3)	-47	± 345	CW
		-47	$\pm 1\ 780$	5 MHz E-UTRA signal, 1 RB (note 2)

NOTE 1: P_{REFSENS} is related to the channel bandwidth as specified in clause 4.2.14.2.

NOTE 2: Interfering signal consisting of one resource block positioned at the stated offset, the channel bandwidth of the interfering signal is located adjacently to the lower/upper Base Station RF Bandwidth edge.

NOTE 3: This requirement shall apply only for an FRC A1-3 (see ETSI TS 136 141 [1], clause A.1) mapped to the frequency range at the channel edge adjacent to the interfering signals.

Table 4.2.9.2-7: Intermodulation performance requirement for E-UTRA with NB-IoT in-band operation BS

BS type	Wanted signal mean power [dBm]	Interfering signal mean power [dBm]	Type of interfering signal
Wide Area BS	$P_{\text{REFSENS}} + 6$ dB (note)	-52	See table 4.2.9.2-2
NOTE: P_{REFSENS} depends on the sub-carrier spacing as specified in clause 4.2.14.2.			

Table 4.2.9.2-8: Intermodulation performance requirement for E-UTRA with NB-IoT guard band operation BS

BS type	Wanted signal mean power [dBm]	Interfering signal mean power [dBm]	Type of interfering signal
Wide Area BS	$P_{\text{REFSENS}} + 6$ dB (note)	-52	See table 4.2.9.2-2
NOTE: P_{REFSENS} depends on the sub-carrier spacing as specified in clause 4.2.14.2.			

Table 4.2.9.2-9: Intermodulation performance requirement for NB-IoT standalone

	NB-IoT channel bandwidth of the lowest/highest carrier received [kHz]	Wanted signal mean power [dBm]	Interfering signal mean power [dBm]	Type of interfering signal
Wide Area BS	200	$P_{\text{REFSENS}} + 6$ dB (note)	-52	See table 4.2.9.2-10
NOTE: P_{REFSENS} depends on the sub-carrier spacing as specified in clause 4.2.14.2.				

Table 4.2.9.2-10: Interfering signal for Intermodulation performance requirement for NB-IoT standalone operation BS

Channel bandwidth of the lowest/highest carrier received [MHz]	Interfering signal centre frequency offset from the lower/upper Base Station RF Bandwidth edge [MHz]	Type of interfering signal
0,2	$\pm 7,575$	CW
	$\pm 17,5$	5 MHz E-UTRA signal

Table 4.2.9.2-11: Narrowband intermodulation performance requirement for Wide Area BS for E-UTRA with NB-IoT in-band operation BS

E-UTRA channel bandwidth of the lowest/highest carrier received [MHz]	Wanted signal mean power [dBm]	Interfering signal mean power [dBm]	Interfering RB centre frequency offset from the lower/upper Base Station RF Bandwidth edge or sub-block edge inside a sub-block gap [kHz]	Type of interfering signal
3	$P_{\text{REFSENS}} + 6 \text{ dB}$ (note 1)	-52	± 270	CW
		-52	± 780	3,0 MHz E-UTRA signal, 1 RB (note 2)
5	$P_{\text{REFSENS}} + 6 \text{ dB}$ (note 1)	-52	± 360 (note 4)	CW
		-52	$\pm 1\ 060$	5 MHz E-UTRA signal, 1 RB (note 2)
10	$P_{\text{REFSENS}} + 6 \text{ dB}$ (notes 1 and 3)	-52	± 325 (note 4)	CW
		-52	$\pm 1\ 240$	5 MHz E-UTRA signal, 1 RB (note 2)
15	$P_{\text{REFSENS}} + 6 \text{ dB}$ (notes 1 and 3)	-52	± 380 (note 4)	CW
		-52	$\pm 1\ 600$	5 MHz E-UTRA signal, 1 RB (note 2)
20	$P_{\text{REFSENS}} + 6 \text{ dB}$ (notes 1 and 3)	-52	± 345 (note 4)	CW
		-52	$\pm 1\ 780$	5 MHz E-UTRA signal, 1 RB (note 2)

NOTE 1: P_{REFSENS} depends on the sub-carrier spacing as specified in clause 4.2.14.2.

NOTE 2: Interfering signal consisting of one resource block positioned at the stated offset, the channel bandwidth of the interfering signal is located adjacently to the lower/upper Base Station RF Bandwidth edge.

NOTE 3: This requirement shall apply only for a FRC A1-3 mapped to the frequency range at the channel edge adjacent to the interfering signals.

NOTE 4: The frequency offset shall be adjusted to accommodate the intermodulation product to fall in the NB-IoT RB for NB-IoT in-band operation.

NOTE 5: If a BS RF receiver fails the test of the requirement, the test shall be performed with the CW interfering signal frequency shifted away from the wanted signal by 180 kHz and the E-UTRA interfering signal frequency shifted away from the wanted signal by 360 kHz. If the BS RF receiver still fails the test after the frequency shift, then the BS RF receiver shall be deemed to fail the requirement.

Table 4.2.9.2-12: Narrowband intermodulation performance requirement for Wide Area BS for E-UTRA with NB-IoT guard band operation BS

E-UTRA channel bandwidth of the lowest/highest carrier received [MHz]	Wanted signal mean power [dBm]	Interfering signal mean power [dBm]	Interfering RB centre frequency offset from the lower/upper Base Station RF Bandwidth edge or sub-block edge inside a sub-block gap [kHz]	Type of interfering signal
5	$P_{\text{REFSENS}} + 6 \text{ dB}$ (note 1)	-52	± 360 (note 4)	CW
		-52	$\pm 1\ 060$	5 MHz E-UTRA signal, 1 RB (note 2)
10	$P_{\text{REFSENS}} + 6 \text{ dB}$ (notes 1 and 3)	-52	± 325 (note 4)	CW
		-52	$\pm 1\ 240$	5 MHz E-UTRA signal, 1 RB (note 2)
15	$P_{\text{REFSENS}} + 6 \text{ dB}$ (notes 1 and 3)	-52	± 380 (note 4)	CW
		-52	$\pm 1\ 600$	5 MHz E-UTRA signal, 1 RB (note 2)
20	$P_{\text{REFSENS}} + 6 \text{ dB}$ (notes 1 and 3)	-52	± 345 (note 4)	CW
		-52	$\pm 1\ 780$	5 MHz E-UTRA signal, 1 RB (note 2)

NOTE 1: P_{REFSENS} depends on the sub-carrier spacing as specified in clause 4.2.14.2.
NOTE 2: Interfering signal consisting of one resource block positioned at the stated offset, the channel bandwidth of the interfering signal is located adjacently to the lower/upper Base Station RF Bandwidth edge.
NOTE 3: This requirement shall apply only for a FRC A1-3 mapped to the frequency range at the channel edge adjacent to the interfering signals.
NOTE 4: The frequency offset shall be adjusted to accommodate the intermodulation product to fall in the NB-IoT RB for NB-IoT guard band operation.
NOTE 5: If a BS RF receiver fails the test of the requirement, the test shall be performed with the CW interfering signal frequency shifted away from the wanted signal by 180 kHz and the E-UTRA interfering signal frequency shifted away from the wanted signal by 360 kHz. If the BS RF receiver still fails the test after the frequency shift, then the BS RF receiver shall be deemed to fail the requirement.

Table 4.2.9.2-13: Narrowband intermodulation performance requirement for Wide Area BS for NB-IoT standalone

Channel bandwidth of the lowest/highest carrier received [MHz]	Wanted signal mean power [dBm]	Interfering signal mean power [dBm]	Interfering RB centre frequency offset from the lower/upper Base Station RF Bandwidth edge or sub-block edge inside a sub-block gap [kHz]	Type of interfering signal
0,2	$P_{\text{REFSENS}} + 6 \text{ dB}$ (note 1)	-52	± 340	CW
		-52	± 880	5 MHz E-UTRA signal, 1 RB (note 2)

NOTE 1: P_{REFSENS} depends on the sub-carrier spacing as specified in clause 4.2.14.2.
NOTE 2: Interfering signal consisting of one resource block positioned at the stated offset, the channel bandwidth of the interfering signal is located adjacently to the lower/upper Base Station RF Bandwidth edge.
NOTE 3: If a BS RF receiver fails the test of the requirement, the test shall be performed with the CW interfering signal frequency shifted away from the wanted signal by 180 kHz and the E-UTRA interfering signal frequency shifted away from the wanted signal by 360 kHz. If the BS RF receiver still fails the test after the frequency shift, then the BS RF receiver shall be deemed to fail the requirement.

4.2.9.3 Conformance

Conformance tests described in clause 5.3.8 shall be carried out.

4.2.10 Adjacent Channel Selectivity (ACS) and narrow-band blocking

4.2.10.1 Definition

Adjacent Channel Selectivity (ACS) and narrow-band blocking are measures of the receiver's ability to receive a wanted signal at its assigned channel frequency in the presence of an adjacent channel signal with a specified centre frequency offset of the interfering signal to the channel edge of a victim system. The interfering signal shall be an E-UTRA signal as specified in ETSI TS 136 141 [1], annex C. For narrowband blocking, the interfering signal is an E-UTRA single resource block.

Unless otherwise stated, a BS declared to be capable of E-UTRA with NB-IoT in-band and guard band operations is only required to pass the ACS and narrow-band blocking receiver tests for E-UTRA with guard band operation. It is not required to perform the ACS and narrow-band blocking receiver tests again for E-UTRA with in-band operation.

For an E-UTRA BS additionally conforming to ETSI EN 301 908-18 [7], either the requirement of the present clause or the Narrowband blocking requirement in clause 4.2.11 of ETSI EN 301 908-18 [7] can be equally applied, as listed in table 4.2.1-2.

4.2.10.2 Limit

For each E-UTRA carrier the throughput shall be ≥ 95 % of the maximum throughput of the reference measurement channel.

For each measured NB-IoT carrier, the throughput shall be ≥ 95 % of the maximum throughput of the reference measurement channel.

For E-UTRA Wide Area BS, the wanted and the interfering signal coupled to the BS antenna input are specified in tables 4.2.10.2-1 and 4.2.10.2-2 for narrowband blocking and table 4.2.10.2-3 for ACS. The reference measurement channel for the wanted signal is specified in table 4.2.14.2-1 for each channel bandwidth and further specified in annex A of ETSI TS 136 141 [1].

For E-UTRA Medium Range BS, the wanted and the interfering signal coupled to the BS antenna input are specified in tables 4.2.10.2-1 and 4.2.10.2-2 for narrowband blocking and in table 4.2.10.2-6 for ACS. The reference measurement channel for the wanted signal is specified in table 4.2.14.2-4 for each channel bandwidth and further specified in annex A of ETSI TS 136 141 [1].

For E-UTRA Local Area BS, the wanted and the interfering signal coupled to the BS antenna input are specified in tables 4.2.10.2-1 and 4.2.10.2-2 for narrowband blocking and table 4.2.10.2-4 for ACS. The reference measurement channel for the wanted signal is specified in table 4.2.14.2-2 for each channel bandwidth and further specified in annex A of ETSI TS 136 141 [1].

For E-UTRA Home BS, the wanted and the interfering signal coupled to the BS antenna input are specified in tables 4.2.10.2-1 and 4.2.10.2-2 for narrowband blocking and table 4.2.10.2-5 for ACS. The reference measurement channel for the wanted signal is specified in table 4.2.14.2-3 for each channel bandwidth and further specified in annex A of ETSI TS 136 141 [1].

For E-UTRA Wide Area BS declared to be capable of NB-IoT in-band, the E-UTRA wanted, the NB-IoT wanted and the interfering signal coupled to the BS antenna input are specified in table 4.2.10.2-1, 4.2.10.2-1A and 4.2.10.2-2 for narrowband blocking and 4.2.10.2-3 and 4.2.10.2-3A for ACS. The reference measurement channel for the E-UTRA wanted signal is specified in table 4.2.14.2-1 for each channel bandwidth. and further specified in ETSI TS 136 141 [1] annex A. The reference measurement channel for the NB-IoT wanted signal is specified in table 4.2.14.2-5 for each sub-carrier spacing and further specified in ETSI TS 136 141 [1], annex A.

For E-UTRA Wide Area BS declared to be capable of NB-IoT guard band, the E-UTRA wanted, the NB-IoT wanted and the interfering signal coupled to the BS antenna input are specified in tables 4.2.10.2-1, 4.2.10.2-1B and 4.2.10.2-2 for narrowband blocking and tables 4.2.10.2-3 and 4.2.10.2-3b for ACS. The reference measurement channel for the E-UTRA wanted signal is specified in table 4.2.14.2-1 for each channel bandwidth and further specified in annex A. The reference measurement channel for the NB-IoT wanted signal is specified in table 4.2.14.2-5 for each sub-carrier spacing and further specified in ETSI TS 136 141 [1], annex A.

For NB-IoT standalone Wide Area BS, the NB-IoT wanted and the interfering signal coupled to the BS antenna input are specified in tables 4.2.10.2-1C and 4.2.10.2-2A for narrowband blocking and table 4.2.10.2-3c for ACS. The reference measurement channel for the NB-IoT wanted signal is specified in table 4.2.14.2-5 for each sub-carrier spacing and further specified in ETSI TS 136 141 [1], annex A.

The ACS and narrowband blocking requirement is applicable outside the Base Station RF Bandwidth or Maximum Radio Bandwidth. The interfering signal offset is defined relative to the Base Station RF Bandwidth edges or Maximum Radio Bandwidth edges.

For a BS operating in non-contiguous spectrum within any operating band, the ACS requirement shall apply in addition inside any sub-block gap, in case the sub-block gap size is at least as wide as the E-UTRA interfering signal in tables 4.2.10.2-3, 4.2.10.2-4 and 4.2.10.2-6. The interfering signal offset is defined relative to the sub-block edges inside the sub-block gap.

For a BS capable of multi-band operation, the ACS requirement shall apply in addition inside any Inter RF Bandwidth gap, in case the Inter RF Bandwidth gap size is at least as wide as the E-UTRA interfering signal in tables 4.2.10.2-3, 4.2.10.2-4 and 4.2.10.2-6. The interfering signal offset is defined relative to the Base Station RF Bandwidth edges inside the Inter RF Bandwidth gap.

For a BS operating in non-contiguous spectrum within any operating band, the narrowband blocking requirement shall apply in addition inside any sub-block gap, in case the sub-block gap size is at least as wide as the channel bandwidth of the E-UTRA interfering signal in table 4.2.10.2-2. The interfering signal offset is defined relative to the sub-block edges inside the sub-block gap.

For a BS capable of multi-band operation, the narrowband blocking requirement shall apply in addition inside any Inter RF Bandwidth gap, in case the Inter RF Bandwidth gap size is at least as wide as the E-UTRA interfering signal in table 4.2.10.2-2. The interfering signal offset is defined relative to the Base Station RF Bandwidth edges inside the Inter RF Bandwidth gap.

Table 4.2.10.2-1: Narrowband blocking requirement

BS class	Wanted signal mean power (dBm)	Interfering signal mean power	Type of interfering signal
Wide Area BS	$P_{\text{REFSENS}} + 6$ dB (note)	-49 dBm	See table 4.2.10.2-2
Medium Range BS	$P_{\text{REFSENS}} + 6$ dB (note)	-44 dBm	See table 4.2.10.2-2
Local Area BS	$P_{\text{REFSENS}} + 6$ dB (note)	-41 dBm	See table 4.2.10.2-2
Home BS	$P_{\text{REFSENS}} + 14$ dB (note)	-33 dBm	See table 4.2.10.2-2
NOTE: P_{REFSENS} depends on the channel bandwidth as specified in clause 4.2.14.2.			

Table 4.2.10.2-1A: Narrowband blocking requirement for NB-IoT in-band operation BS

	E-UTRA channel BW of the lowest/highest carrier received [MHz]	NB-IoT Wanted signal mean power [dBm]	Interfering signal mean power [dBm]	Type of interfering signal
Wide Area BS	3	$P_{\text{REFSENS}} + 11$ dB (note)	-49	See table 4.2.10.2-2
	5	$P_{\text{REFSENS}} + 8$ dB (note)	-49	See table 4.2.10.2-2
	10	$P_{\text{REFSENS}} + 6$ dB (note)	-49	See table 4.2.10.2-2
	15	$P_{\text{REFSENS}} + 6$ dB (note)	-49	See table 4.2.10.2-2
	20	$P_{\text{REFSENS}} + 6$ dB (note)	-49	See table 4.2.10.2-2
NOTE: P_{REFSENS} depends on the sub-carrier spacing as specified in clause 4.2.14.2.				

Table 4.2.10.2-1B: Narrowband blocking requirement for NB-IoT guard band operation BS

	E-UTRA channel BW of the lowest/highest carrier received [MHz]	NB-IoT Wanted signal mean power [dBm] (see notes 1 and 2)	Interfering signal mean power [dBm]	Type of interfering signal
Wide Area BS	5	$P_{\text{REFSENS}} + 11$ dB	-49	See table 4.2.10.2-2
	10	$P_{\text{REFSENS}} + 6$ dB	-49	See table 4.2.10.2-2
	15	$P_{\text{REFSENS}} + 6$ dB	-49	See table 4.2.10.2-2
	20	$P_{\text{REFSENS}} + 6$ dB	-49	See table 4.2.10.2-2
NOTE 1: The mentioned desensitisation values consider only 1 NB-IoT in the guard band.				
NOTE 2: P _{REFSENS} depends on the sub-carrier spacing as specified in clause 4.2.14.2.				

Table 4.2.10.2-1C: Narrowband blocking requirement for NB-IoT standalone

	NB-IoT channel bandwidth of the lowest/highest carrier received [kHz]	Wanted signal mean power [dBm]	Interfering signal mean power [dBm]	Type of interfering signal
Wide Area BS	200	$P_{\text{REFSENS}} + 12$ dB (note)	-49	See table 4.2.10.2-2A
NOTE: P _{REFSENS} depends on the sub-carrier spacing as specified in clause 4.2.14.2.				

Table 4.2.10.2-2: Interfering signal for Narrowband blocking requirement for E-UTRA BS

E-UTRA channel BW of the lowest/highest carrier received (MHz)	Interfering RB centre frequency offset to the lower/upper Base Station RF Bandwidth edge or sub-block edge inside a sub-block gap (kHz)	Type of interfering signal
1,4	$\pm(252,5 + m \times 180)$, $m = 0, 1, 2, 3, 4, 5$	1,4 MHz E-UTRA signal, 1 RB (note)
3	$\pm(247,5 + m \times 180)$, $m = 0, 1, 2, 3, 4, 7, 10, 13$	3 MHz E-UTRA signal, 1 RB (note)
5	$\pm(342,5 + m \times 180)$, $m = 0, 1, 2, 3, 4, 9, 14, 19, 24$	5 MHz E-UTRA signal, 1 RB (note)
10	$\pm(347,5 + m \times 180)$, $m = 0, 1, 2, 3, 4, 9, 14, 19, 24$	5 MHz E-UTRA signal, 1 RB (note)
15	$\pm(352,5 + m \times 180)$, $m = 0, 1, 2, 3, 4, 9, 14, 19, 24$	5 MHz E-UTRA signal, 1 RB (note)
20	$\pm(342,5 + m \times 180)$, $m = 0, 1, 2, 3, 4, 9, 14, 19, 24$	5 MHz E-UTRA signal, 1 RB (note)
NOTE: Interfering signal consisting of one resource block is positioned at the stated offset, the channel bandwidth of the interfering signal is located adjacently to the lower/upper Base Station RF Bandwidth edge. Frequency offsets are such that the interfering signal is outside the channel.		

Table 4.2.10.2-2A: Interfering signal for Narrowband blocking requirement for NB-IoT standalone operation BS

NB-IoT channel bandwidth of the lowest/highest carrier received [kHz]	Interfering RB centre frequency offset to the lower/upper Base Station RF Bandwidth edge or sub-block edge inside a sub-block gap [kHz]	Type of interfering signal
200	$\pm(240 + m \times 180)$, M = 0, 1, 2, 3, 4, 9, 14	3 MHz E-UTRA signal, 1 RB (note)
NOTE: Interfering signal consisting of one resource block is positioned at the stated offset, the channel bandwidth of the interfering signal is located adjacently to the lower/upper Base Station RF Bandwidth edge.		

Table 4.2.10.2-3: Adjacent channel selectivity for E-UTRA Wide Area BS

E-UTRA channel bandwidth of the lowest/highest carrier received (MHz)	Wanted signal mean power (dBm)	Interfering signal mean power (dBm)	Interfering signal centre frequency offset from the lower/upper Base Station RF Bandwidth edge or sub-block edge inside a sub-block gap (MHz)	Type of interfering signal
1,4	$P_{\text{REFSENS}} + 11$ dB (note)	-52	$\pm 0,7025$	1,4 MHz E-UTRA signal
3	$P_{\text{REFSENS}} + 8$ dB (note)	-52	$\pm 1,5075$	3 MHz E-UTRA signal
5	$P_{\text{REFSENS}} + 6$ dB (note)	-52	$\pm 2,5025$	5 MHz E-UTRA signal
10	$P_{\text{REFSENS}} + 6$ dB (note)	-52	$\pm 2,5075$	5 MHz E-UTRA signal
15	$P_{\text{REFSENS}} + 6$ dB (note)	-52	$\pm 2,5125$	5 MHz E-UTRA signal
20	$P_{\text{REFSENS}} + 6$ dB (note)	-52	$\pm 2,5025$	5 MHz E-UTRA signal
NOTE: P_{REFSENS} depends on the channel bandwidth as specified in clause 4.2.14.2. Frequency offsets are such that the interfering signal is outside the channel.				

Table 4.2.10.2-3A: Adjacent channel selectivity for NB-IoT in-band operation Wide Area BS

E-UTRA channel bandwidth of the lowest/highest carrier received [MHz]	NB-IoT wanted signal mean power [dBm]	Interfering signal mean power [dBm]	Interfering signal centre frequency offset from the lower/upper Base Station RF Bandwidth edge or sub-block edge inside a sub-block gap [MHz]	Type of interfering signal
3	$P_{\text{REFSENS}} + 8 \text{ dB}$ (note)	-52	$\pm 1,5075$	3 MHz E-UTRA signal
5	$P_{\text{REFSENS}} + 6 \text{ dB}$ (note)	-52	$\pm 2,5025$	5 MHz E-UTRA signal
10	$P_{\text{REFSENS}} + 6 \text{ dB}$ (note)	-52	$\pm 2,5075$	5 MHz E-UTRA signal
15	$P_{\text{REFSENS}} + 6 \text{ dB}$ (note)	-52	$\pm 2,5125$	5 MHz E-UTRA signal
20	$P_{\text{REFSENS}} + 6 \text{ dB}$ (note)	-52	$\pm 2,5025$	5 MHz E-UTRA signal

NOTE: P_{REFSENS} depends on the sub-carrier spacing as specified in clause 4.2.14.2.

Table 4.2.10.2-3B: Adjacent channel selectivity NB-IoT guard band operation Wide Area BS

E-UTRA channel bandwidth of the lowest/highest carrier received [MHz]	NB-IoT wanted signal mean power [dBm]	Interfering signal mean power [dBm]	Interfering signal centre frequency offset from the lower/upper Base Station RF Bandwidth edge or sub-block edge inside a sub-block gap [MHz]	Type of interfering signal
5	$P_{\text{REFSENS}} + 10 \text{ dB}$ (note)	-52	$\pm 2,5025$	5 MHz E-UTRA signal
10	$P_{\text{REFSENS}} + 8 \text{ dB}$ (note)	-52	$\pm 2,5075$	5 MHz E-UTRA signal
15	$P_{\text{REFSENS}} + 6 \text{ dB}$ (note)	-52	$\pm 2,5125$	5 MHz E-UTRA signal
20	$P_{\text{REFSENS}} + 6 \text{ dB}$ (note)	-52	$\pm 2,5025$	5 MHz E-UTRA signal

NOTE: P_{REFSENS} depends on the sub-carrier spacing as specified in clause 4.2.14.2.

Table 4.2.10.2-3C: Adjacent channel selectivity for NB-IoT standalone Wide Area BS

NB-IoT channel bandwidth of the lowest/highest carrier received [kHz]	Wanted signal mean power [dBm]	Interfering signal mean power [dBm]	Interfering signal centre frequency offset to the lower/upper Base Station RF Bandwidth edge or sub-block edge inside a sub-block gap [kHz]	Type of interfering signal
200	$P_{\text{REFSENS}} + 19,5 \text{ dB}$ (note)	-52	± 100	180 kHz NB-IoT signal

NOTE: P_{REFSENS} depends on the sub-carrier spacing as specified in clause 4.2.14.2.

Table 4.2.10.2-4: Adjacent channel selectivity for E-UTRA Local Area BS

E-UTRA channel bandwidth of the lowest/highest carrier received (MHz)	Wanted signal mean power (dBm)	Interfering signal mean power (dBm)	Interfering signal centre frequency offset from the lower/upper Base Station RF Bandwidth edge or sub-block edge inside a sub-block gap (MHz)	Type of interfering signal
1,4	$P_{\text{REFSENS}} + 11$ dB (note)	-44	$\pm 0,7025$	1,4 MHz E-UTRA signal
3	$P_{\text{REFSENS}} + 8$ dB (note)	-44	$\pm 1,5075$	3 MHz E-UTRA signal
5	$P_{\text{REFSENS}} + 6$ dB (note)	-44	$\pm 2,5025$	5 MHz E-UTRA signal
10	$P_{\text{REFSENS}} + 6$ dB (note)	-44	$\pm 2,5075$	5 MHz E-UTRA signal
15	$P_{\text{REFSENS}} + 6$ dB (note)	-44	$\pm 2,5125$	5 MHz E-UTRA signal
20	$P_{\text{REFSENS}} + 6$ dB (note)	-44	$\pm 2,5025$	5 MHz E-UTRA signal

NOTE: P_{REFSENS} depends on the channel bandwidth as specified in clause 4.2.14.2.
Frequency offsets are such that the interfering signal is outside the channel.

Table 4.2.10.2-5: Adjacent channel selectivity for E-UTRA Home BS

E-UTRA channel bandwidth (MHz)	Wanted signal mean power (dBm)	Interfering signal mean power (dBm)	Interfering signal centre frequency offset from the channel edge of the wanted signal (MHz)	Type of interfering signal
1,4	$P_{\text{REFSENS}} + 27$ dB (note)	-28	0,7025	1,4 MHz E-UTRA signal
3	$P_{\text{REFSENS}} + 24$ dB (note)	-28	1,5075	3 MHz E-UTRA signal
5	$P_{\text{REFSENS}} + 22$ dB (note)	-28	2,5025	5 MHz E-UTRA signal
10	$P_{\text{REFSENS}} + 22$ dB (note)	-28	2,5075	5 MHz E-UTRA signal
15	$P_{\text{REFSENS}} + 22$ dB (note)	-28	2,5125	5 MHz E-UTRA signal
20	$P_{\text{REFSENS}} + 22$ dB (note)	-28	2,5025	5 MHz E-UTRA signal

NOTE: P_{REFSENS} depends on the channel bandwidth as specified in clause 4.2.14.2.
Frequency offsets are such that the interfering signal is outside the channel.

Table 4.2.10.2-6: Adjacent channel selectivity for E-UTRA Medium Range BS

E-UTRA channel bandwidth of the lowest/highest carrier received (MHz)	Wanted signal mean power (dBm)	Interfering signal mean power (dBm)	Interfering signal centre frequency offset from the channel edge of the wanted signal (MHz)	Type of interfering signal
1,4	$P_{\text{REFSENS}} + 11$ dB (note)	-47	0,7025	1,4 MHz E-UTRA signal
3	$P_{\text{REFSENS}} + 8$ dB (note)	-47	1,5075	3 MHz E-UTRA signal
5	$P_{\text{REFSENS}} + 6$ dB (note)	-47	2,5025	5 MHz E-UTRA signal
10	$P_{\text{REFSENS}} + 6$ dB (note)	-47	2,5075	5 MHz E-UTRA signal
15	$P_{\text{REFSENS}} + 6$ dB (note)	-47	2,5125	5 MHz E-UTRA signal
20	$P_{\text{REFSENS}} + 6$ dB (note)	-47	2,5025	5 MHz E-UTRA signal

NOTE: P_{REFSENS} depends on the channel bandwidth as specified in clause 4.2.14.2.
Frequency offsets are such that the interfering signal is outside the channel.

4.2.10.3 Conformance

Conformance tests described in clause 5.3.9 shall be carried out.

4.2.11 Home BS output power for adjacent UTRA channel protection

4.2.11.1 Definition

The Home BS shall be capable of adjusting the transmitter output power to minimize the interference level on the adjacent channels while optimize the Home BS coverage, in case an adjacent channel is licensed to another operator in the same geographical area. These requirements are only applicable to Home BS. The requirements in this clause are applicable for AWGN radio propagation conditions.

4.2.11.2 Limit

The output power, P_{out} , of the Home BS shall be as specified in table 4.2.11.2-1 under the following input conditions:

- $\text{CPICH } \hat{E}_c$, measured in dBm, is the code power of the Primary CPICH on one of the adjacent channels presented at the Home BS antenna connector for the CPICH received on the adjacent channels. If Tx diversity is applied on the Primary CPICH, $\text{CPICH } \hat{E}_c$ shall be the sum (in W) of the code powers of the Primary CPICH transmitted from each antenna.
- I_{oh} , measured in dBm, is the total received power density, including signals and interference but excluding the own Home BS signal, present at the Home BS antenna connector on the Home BS operating channel.

The input conditions defined for the requirements in this clause are specified at the antenna connector of the Home BS. For Home BS receivers with diversity, the requirements apply to each antenna connector separately, with the other one(s) terminated or disabled.

NOTE: The present requirement verifies the mandatory mechanism for Home BS output power for adjacent UTRA channel protection, assuming that there is an adjacent UTRA channel licensed to another operator that needs protection. For a Home BS in operation and in case that both adjacent channels are licensed to other operators, the most stringent requirement is applied for P_{out} . In the case when one of the adjacent channels is licensed to an E-UTRA operator while the other adjacent channel is licensed to a UTRA operator, the more stringent requirement of this clause and in clause 4.2.12 is applied for P_{out} .

Table 4.2.11.2-1: Home BS output power for adjacent operator UTRA channel protection

Input Conditions	Output power, P_{out}
$I_{oh} > CPICH \hat{E}_c + 43$ dB and $CPICH \hat{E}_c \geq -105$ dBm	≤ 10 dBm
$I_{oh} \leq CPICH \hat{E}_c + 43$ dB and $CPICH \hat{E}_c \geq -105$ dBm	$\leq \max(8 \text{ dBm}, \min(20 \text{ dBm},$ $CPICH \hat{E}_c + 100 \text{ dB}))$
$CPICH \hat{E}_c < -105$ dBm	≤ 20 dBm

In normal operating conditions, the output power, P_{out} , of the Home BS shall be equal to or less than:

- the value specified in table 4.2.11.2-1 plus 2,7 dB for carrier frequency $f \leq 3,0$ GHz;
- the value specified in table 4.2.11.2-1 plus 3,0 dB for carrier frequency $3,0 \text{ GHz} < f \leq 4,2$ GHz.

In extreme operating conditions, the output power, P_{out} , of the Home BS shall be equal to or less than:

- the value specified in table 4.2.11.2-1 plus 3,2 dB for carrier frequency $f \leq 3,0$ GHz;
- the value specified in table 4.2.11.2-1 plus 3,5 dB for carrier frequency $3,0 \text{ GHz} < f \leq 4,2$ GHz.

4.2.11.3 Conformance

Conformance tests described in clause 5.3.10 shall be carried out.

4.2.12 Home BS output power for adjacent E-UTRA channel protection

4.2.12.1 Definition and applicability

The Home BS shall be capable of adjusting the transmitter output power to minimize the interference level on the adjacent channels licensed to other operators in the same geographical area while optimize the Home BS coverage. These requirements are only applicable to Home BS. The requirements in this clause are applicable for AWGN radio propagation conditions.

4.2.12.2 Limit

The output power, P_{out} , of the Home BS shall be as specified in table 4.2.12.2-1 under the following input conditions:

- $CRS \hat{E}_s$, measured in dBm, is the Reference Signal Received Power per resource element on one of the adjacent channels present at the Home BS antenna connector for the Reference Signal received on the adjacent channels. For $CRS \hat{E}_s$ determination, the cell-specific reference signal R0 according ETSI TS 136 211 [6] shall be used. If the Home BS can reliably detect that multiple TX antennas are used for transmission on the adjacent channel, it may use the average in [W] of the $CRS \hat{E}_s$ on all detected antennas.
- I_{oh} , measured in dBm, is the total received power density, including signals and interference but excluding the own Home BS signal, present at the Home BS antenna connector on the Home BS operating channel.

The input conditions defined for the requirements in this clause are specified at the antenna connector of the Home BS. For Home BS receivers with diversity, the requirements apply to each antenna connector separately, with the other one(s) terminated or disabled.

NOTE: The present requirement verifies the mandatory mechanism for Home BS output power for adjacent E-UTRA channel protection, assuming that there is an adjacent E-UTRA channel licensed to another operator that needs protection. For a Home BS in operation and in case that both adjacent channels are licensed to other operators, the most stringent requirement is applied for P_{out} . In the case when one of the adjacent channels is licensed to an E-UTRA operator while the other adjacent channel is licensed to a UTRA operator, the more stringent requirement of this clause and in clause 4.2.11 is applied for P_{out} .

Table 4.2.12.2-1: Home BS output power for adjacent operator E-UTRA channel protection

Input Conditions	Output power, P_{out}
$I_{oh} > CRS \hat{E}_s + 10 \cdot \log_{10}(N_{RB}^{DL} \cdot N_{sc}^{RB}) + 30$ dB and $CRS \hat{E}_s \geq -127$ dBm	≤ 10 dBm
$I_{oh} \leq CRS \hat{E}_s + 10 \cdot \log_{10}(N_{RB}^{DL} \cdot N_{sc}^{RB}) + 30$ dB and $CRS \hat{E}_s \geq -127$ dBm	$\leq \max(8 \text{ dBm}, \min(20 \text{ dBm}, CRS \hat{E}_s + 10 \cdot \log_{10}(N_{RB}^{DL} \cdot N_{sc}^{RB}) + 85 \text{ dB}))$
$CRS \hat{E}_s < -127$ dBm	≤ 20 dBm

In normal operating conditions, the output power, P_{out} , of the Home BS shall be equal to or less than:

- the value specified in table 4.2.12.2-1 plus 2,7 dB for carrier frequency $f \leq 3,0$ GHz;
- the value specified in table 4.2.12.2-1 plus 3,0 dB for carrier frequency $3,0 \text{ GHz} < f \leq 4,2$ GHz.

In extreme operating conditions, the output power, P_{out} , of the Home BS shall be equal to or less than:

- the value specified in table 4.2.12.2-1 plus 3,2 dB for carrier frequency $f \leq 3,0$ GHz;
- the value specified in table 4.2.12.2-1 plus 3,5 dB for carrier frequency $3,0 \text{ GHz} < f \leq 4,2$ GHz.

4.2.12.3 Conformance

Conformance tests described in clause 5.3.11 shall be carried out.

4.2.13 Home BS output power for co-channel E-UTRA protection

4.2.13.1 Definition and applicability

To minimize the co-channel DL interference to non-CSG macro UEs operating in close proximity while optimizing the CSG Home BS coverage, Home BS may adjust its output power according to the requirements set out in this clause. These requirements are only applicable to Home BS. The requirements in this clause are applicable for AWGN radio propagation conditions.

4.2.13.2 Limit

For Home BS that supports the requirements in this clause, the output power, P_{out} , of the Home BS shall be as specified in table 4.2.13.2-1 under the following input conditions:

- $CRS \hat{E}_s$, measured in dBm, is the Reference Signal Received Power per resource element present at the Home BS antenna connector received from the co-channel Wide Area BS. For $CRS \hat{E}_s$ determination, the cell-specific reference signal R0 according ETSI TS 136 211 [6] shall be used. If the Home BS can reliably detect that multiple TX antenna ports are used for transmission by the co-channel Wide Area Base Station, it may use the average in [W] of the $CRS \hat{E}_s$ on all detected TX antenna ports, including R0.
- I_{oh} , measured in dBm, is the total received DL power, including all interference but excluding the own Home BS signal, present at the Home BS antenna connector on the Home BS operating channel.
- I_{ob} , measured in dBm, is the uplink received interference power, including thermal noise, within one physical resource block's bandwidth of N_{sc}^{RB} resource elements as defined in ETSI TS 136 214 [i.9], present at the Home BS antenna connector on the Home BS operating channel.

The input conditions defined for the requirements in this clause are specified at the antenna connector of the Home BS. For Home BS receivers with diversity, the requirements apply to each antenna connector separately, with the other one(s) terminated or disabled.

Table 4.2.13.2-1: Home BS output power for co-channel E-UTRA channel protection

Input Conditions	Output power, P_{out}
$l_{oh} (DL) > CRS \hat{E}_s + 10 \cdot \log_{10} (N_{RB}^{DL} \cdot N_{sc}^{RB}) + 30 \text{ dB}$ and Option 1: $CRS \hat{E}_s \geq -127 \text{ dBm}$ or Option 2: $CRS \hat{E}_s \geq -127 \text{ dBm}$ and $l_{ob} > -103 \text{ dBm}$	$\leq 10 \text{ dBm}$
$l_{oh} (DL) \leq CRS \hat{E}_s + 10 \cdot \log_{10} (N_{RB}^{DL} \cdot N_{sc}^{RB}) + 30 \text{ dB}$ and Option 1: $CRS \hat{E}_s \geq -127 \text{ dBm}$ or Option 2: $CRS \hat{E}_s \geq -127 \text{ dBm}$ and $l_{ob} > -103 \text{ dBm}$	$\leq \max (P_{min}, \min (, CRS \hat{E}_s + P_{max,c} 10 \cdot \log_{10} (N_{RB}^{DL} \cdot N_{sc}^{RB}) + X))$ $30 \text{ dB} \leq X \leq 70 \text{ dB}$ $P_{min} = -10 \text{ dBm}$
Option 1: $CRS \hat{E}_s < -127 \text{ dBm}$ or Option 2: $CRS \hat{E}_s < -127 \text{ dBm}$ and $l_{ob} \leq -103 \text{ dBm}$	$\leq 20 \text{ dBm}$

In normal operating conditions, the output power, P_{out} , of the Home BS shall be equal to or less than:

- the value specified in table 4.2.13.2-1 plus 2,7 dB for carrier frequency $f \leq 3,0 \text{ GHz}$;
- the value specified in table 4.2.13.2-1 plus 3,0 dB for carrier frequency $3,0 \text{ GHz} < f \leq 4,2 \text{ GHz}$.

In extreme operating conditions, the output power, P_{out} , of the Home BS shall be equal to or less than:

- the value specified in table 4.2.13.2-1 plus 3,2 dB for carrier frequency $f \leq 3,0 \text{ GHz}$;
- the value specified in table 4.2.13.2-1 plus 3,5 dB for carrier frequency $3,0 \text{ GHz} < f \leq 4,2 \text{ GHz}$.

4.2.13.3 Conformance

Conformance tests described in clause 5.3.12 shall be carried out.

4.2.14 Reference sensitivity level

4.2.14.1 Definition

The reference sensitivity level $P_{REFSENS}$ is the minimum mean power received at the antenna connector at which a throughput requirement shall be met for a specified reference measurement channel.

4.2.14.2 Limits

For each measured E-UTRA carrier, the throughput shall be $\geq 95 \%$ of the maximum throughput of the reference measurement channel as specified in clause A.1 in ETSI TS 136 141 [1] with parameters specified in table 4.2.14.2-1 for Wide Area BS, in table 4.2.14.2-2 for Local Area BS, in table 4.2.14.2-3 for Home BS and in table 4.2.14.2-4 for Medium Range BS.

Table 4.2.14.2-1: E-UTRA Wide Area BS reference sensitivity levels

E-UTRA channel bandwidth [MHz]	Reference measurement channel, as specified in clause A.1 ETSI TS 136 141 [1]	Reference sensitivity level, P_{REFSENS} [dBm]	
		$f \leq 3,0$ GHz	$3,0$ GHz $< f \leq 4,2$ GHz
1,4	FRC A1-1	-106,1	-105,8
3	FRC A1-2	-102,3	-102,0
3	FRC A1-6 for E-UTRA with NB-IoT in-band operation (note 3)	-102,3 (note 2)	N/A
5	FRC A1-3	-100,8	-100,5
5	FRC A1-7 for E-UTRA with NB-IoT in-band operation	-100,8 (note 2)	N/A
10	FRC A1-3 (note 1)	-100,8	-100,5
10	FRC A1-7 for E-UTRA with NB-IoT in-band operation (note 4)	-100,8 (note 2)	N/A
15	FRC A1-3 (note 1)	-100,8	-100,5
15	FRC A1-7 for E-UTRA with NB-IoT in-band operation (note 4)	-100,8 (note 2)	N/A
20	FRC A1-3 (note 1)	-100,8	-100,5
20	FRC A1-7 in for E-UTRA with NB-IoT in-band operation (note 4)	-100,8 (note 2)	N/A

NOTE 1: P_{REFSENS} is the power level of a single instance of the reference measurement channel. This requirement shall be met for each consecutive application of a single instance of FRC A1-3 mapped to disjoint frequency ranges with a width of 25 resource blocks each.

NOTE 2: The requirements apply to BS that supports E-UTRA with NB-IoT in-band operation.

NOTE 3: P_{REFSENS} is the power level of a single instance of the reference measurement channel. This requirement shall be met for a single instance of FRC A1-6 mapped to the 12 E-UTRA resource blocks adjacent to the NB-IoT PRB.

NOTE 4: P_{REFSENS} is the power level of a single instance of the reference measurement channel. This requirement shall be met for a single instance of FRC A1-7 mapped to the 24 E-UTRA resource blocks adjacent to the NB-IoT PRB (location of which is specified in ETSI TS 136 141 [1], clause 4.7.3), and for each consecutive application of a single instance of FRC A1-3 mapped to disjoint frequency ranges with a width of 25 resource blocks each.

Table 4.2.14.2-2: E-UTRA Local Area BS reference sensitivity levels

E-UTRA channel bandwidth [MHz]	Reference measurement channel	Reference sensitivity level, P_{REFSENS} [dBm]	
		$f \leq 3,0$ GHz	$3,0$ GHz $< f \leq 4,2$ GHz
1,4	FRC A1-1 in clause A.1	-98,1	-97,8
3	FRC A1-2 in clause A.1	-94,3	-94,0
5	FRC A1-3 in clause A.1	-92,8	-92,5
10	FRC A1-3 in clause A.1 (note)	-92,8	-92,5
15	FRC A1-3 in clause A.1 (note)	-92,8	-92,5
20	FRC A1-3 in clause A.1 (note)	-92,8	-92,5

NOTE: P_{REFSENS} is the power level of a single instance of the reference measurement channel. This requirement shall be met for each consecutive application of a single instance of FRC A1-3 mapped to disjoint frequency ranges with a width of 25 resource blocks each.

Table 4.2.14.2-3: E-UTRA Home BS reference sensitivity levels

E-UTRA channel bandwidth [MHz]	Reference measurement channel	Reference sensitivity level, P_{REFSENS} [dBm]	
		$f \leq 3,0$ GHz	$3,0$ GHz $< f \leq 4,2$ GHz
1,4	FRC A1-1 in clause A.1	-98,1	-97,8
3	FRC A1-2 in clause A.1	-94,3	-94,0
5	FRC A1-3 in clause A.1	-92,8	-92,5
10	FRC A1-3 in clause A.1 (note)	-92,8	-92,5
15	FRC A1-3 in clause A.1 (note)	-92,8	-92,5
20	FRC A1-3 in clause A.1 (note)	-92,8	-92,5

NOTE: P_{REFSENS} is the power level of a single instance of the reference measurement channel. This requirement shall be met for each consecutive application of a single instance of FRC A1-3 mapped to disjoint frequency ranges with a width of 25 resource blocks each.

Table 4.2.14.2-4: E-UTRA Medium Range BS reference sensitivity levels

E-UTRA channel bandwidth [MHz]	Reference measurement channel	Reference sensitivity level, P_{REFSENS} [dBm]	
		$f \leq 3,0$ GHz	$3,0$ GHz $< f \leq 4,2$ GHz
1,4	FRC A1-1 in clause A.1	-101,1	-100,8
3	FRC A1-2 in clause A.1	-97,3	-97,0
5	FRC A1-3 in clause A.1	-95,8	-95,5
10	FRC A1-3 in clause A.1 (note)	-95,8	-95,5
15	FRC A1-3 in clause A.1 (note)	-95,8	-95,5
20	FRC A1-3 in clause A.1 (note)	-95,8	-95,5

NOTE: P_{REFSENS} is the power level of a single instance of the reference measurement channel. This requirement shall be met for each consecutive application of a single instance of FRC A1-3 mapped to disjoint frequency ranges with a width of 25 resource blocks each.

For NB-IoT standalone BS or E-UTRA BS with NB-IoT (in-band and/or guard band), NB-IoT throughput shall be ≥ 95 % of the maximum throughput of the reference measurement channel with parameters specified in table 4.2.14.2-5 for Wide Area BS.

Table 4.2.14.2-5: NB-IoT Wide Area BS reference sensitivity levels

NB-IoT channel bandwidth [kHz]	NB-IoT Sub-carrier spacing [kHz]	Reference measurement channel, as specified in clause A.14 ETSI TS 136 141 [1]	Reference sensitivity level, P_{REFSENS} [dBm] ($f \leq 3,0$ GHz)
200	15	FRC A14-1	-126,6
200	3,75	FRC A14-2	-132,6

4.2.14.3 Conformance

Conformance tests described in clause 5.3.13 shall be carried out.

4.2.15 Downlink channel access procedure (Listen before talk - LBT)

4.2.15.1 General

Channel access procedure for downlink operation in band 46 for PDSCH transmission shall be implemented as it is described in clause 15 in ETSI TS 136 213 [9].

This requirement shall only apply to E-UTRA BS operation in band 46.

4.2.15.2 Limits

In normal conditions, the measurement result shall meet channel access related test requirements for PDSCH as listed in table 4.2.15.2-1.

Table 4.2.15.2-1: Channel access test requirements for PDSCH

Parameter	Unit	Value
LBT measurement bandwidth	MHz	20
Maximum energy detection threshold	dBm/20 MHz	-72 + 4 dB
Maximum channel occupancy time	ms	8

The Base Station shall be able to assess whether the medium is busy or idle with at least 90 % probability, using a channel access procedure with the parameters in table 4.2.15.2-1.

4.2.15.3 Conformance

Conformance tests described in clause 5.3.14 shall be carried out.

4.2.16 Dynamic Frequency Selection (DFS)

4.2.16.1 General

When operating in the sub-bands 46b and 46c the BS shall use mitigation techniques that give at least the same protection as the detection, operational and response requirements described in ETSI EN 301 893 [8] to ensure compatible operation with radiodetermination systems. Such mitigation techniques shall equalize the probability of selecting a channel for all available channels so as to ensure, on average, a near-uniform spread of spectrum loading.

This requirement shall only apply to E-UTRA BS operation in band 46.

4.2.16.2 Limits

The DFS requirements specified in ETSI EN 301 893 [8], clause 4.2.6 shall apply.

4.2.16.3 Conformance

Conformance tests described in clause 5.3.15 shall be carried out.

4.2.17 Base Station output power (band 46)

4.2.17.1 General

For E-UTRA BS operation in band 46 the output power shall be in compliance with the requirements contained in ETSI EN 301 893 [8], clause 4.2.3.

NOTE: ETSI EN 301 893 [8], clause 4.2.3 implements the technical conditions contained in EC decisions [i.10], [i.11] in a technology neutral manner.

4.2.17.2 Limits

The requirements on output power specified in ETSI EN 301 893 [8], clause 4.2.3 shall apply.

4.2.17.3 Conformance

Conformance tests described in clause 5.3.16 shall be carried out.

5 Testing for compliance with technical requirements

5.1 Environmental conditions for testing

Tests defined in the present document shall be carried out at representative points within the boundary limits of the declared operational environmental profile.

Where technical performance varies subject to environmental conditions, tests shall be carried out under a sufficient variety of environmental conditions (within the boundary limits of the declared operational environmental profile) to give confidence of compliance for the affected technical requirements.

Normally it should be sufficient for all tests to be conducted using normal test conditions except where otherwise stated. For guidance on the use of other test conditions to be used in order to show compliance reference can be made to ETSI TS 136 141 [1], annex D.

5.2 Interpretation of the measurement results

The interpretation of the results recorded in a test report for the measurements described in the present document shall be as follows:

- the measured value related to the corresponding limit will be used to decide whether an equipment meets the requirements of the present document;
- the value of the measurement uncertainty for the measurement of each parameter shall be included in the test report.

For the test methods, the recommended values of the maximum measurement uncertainty are calculated and correspond to an expansion factor (coverage factor) $k = 1,96$ or $k = 2$ (which provide confidence levels of respectively 95 % and 95,45 % in the case where the distributions characterizing the actual measurement uncertainties are normal (Gaussian)). Principles for the calculation of measurement uncertainty are contained in ETSI TR 100 028 [i.5], in particular in annex D of the ETSI TR 100 028-2 [i.5].

Recommended values for the maximum measurements uncertainty can be found in annex C.

Table 5.2-1: void

5.3 Essential radio test suites

5.3.0 Introduction

This clause describes the test suites for E-UTRA (FDD and TDD).

The test configurations and channel spacing for multi-carrier operations that shall be used for demonstrating conformance are specified in clauses 4.10, 5.7.1 and 5.7.1A of ETSI TS 136 141 [1].

For the single carrier testing many tests in the present document are performed with appropriate frequencies in the bottom, middle and top of the operating band of the BS. These are denoted as RF channels B (bottom), M (middle) and T (top) and are defined in ETSI TS 136 141 [1], clause 4.7.

For single-band multi-carrier testing many tests in the present document are performed with the maximum Base Station RF Bandwidth position located at the bottom, middle and top of the supported frequency range in each operating band. These are denoted as B_{RFBW} (bottom), M_{RFBW} (middle) and T_{RFBW} (top) for non-aggregated channels and are defined in ETSI TS 136 141 [1], clause 4.7.1.

For dual-band testing many tests in the present document are performed with the Base Station RF Bandwidths located at bottom of the supported frequency range in the lower operating band and at the top of the supported frequency range in the upper operating band. These are denoted as $B_{\text{RFBW-T}'_{\text{RFBW}}}$ and $B'_{\text{RFBW-T}}_{\text{RFBW}}$ and are defined in ETSI TS 136 141 [1], clause 4.7.1. The measurement system required for each test is described in ETSI TS 136 141 [1], annex I.

Unless otherwise stated, a BS declared to be capable of E-UTRA with NB-IoT in-band or guard band operations is only required to pass the transmitter and receiver tests for E-UTRA with NB-IoT in-band or guard band; it is not required to perform the transmitter tests again for E-UTRA only.

NB-IoT testing shall be performed with the NB-IoT signal located as described in clause 4.7.3 of ETSI TS 136 141 [1].

5.3.1 Operating band unwanted emissions

5.3.1.0 General

For an E-UTRA BS additionally conforming to ETSI EN 301 908-18 [7], either the test suite of the present clause or the Operating band unwanted emissions test suite in clause 5.3.1 of ETSI EN 301 908-18 [7] can be equally applied, as listed in table 4.2.1-2.

5.3.1.1 Initial conditions

Test environment: normal; see ETSI TS 136 141 [1], clause D.2.

RF channels to be tested for single-carrier: B, M and T; see clause 5.3.0.

Base Station RF Bandwidth positions to be tested:

- $B_{\text{RFBW}}, M_{\text{RFBW}}$ and T_{RFBW} in single-band operation; see clause 5.3.0.
- $B_{\text{RFBW-T}'_{\text{RFBW}}}$ and $B'_{\text{RFBW-T}}_{\text{RFBW}}$ in multi-band operation; see clause 5.3.0.

Test set-up:

- 1) Connect the signal analyser to the Base Station Antenna connector as shown in ETSI TS 136 141 [1], clause I.1.1.

As a general rule, the resolution bandwidth of the measuring equipment should be equal to the measurement bandwidth. However, to improve measurement accuracy, sensitivity, efficiency and avoiding e.g. carrier leakage, the resolution bandwidth may be smaller than the measurement bandwidth. When the resolution bandwidth is smaller than the measurement bandwidth, the result should be integrated over the measurement bandwidth in order to obtain the equivalent noise bandwidth of the measurement bandwidth.

- 2) Detection mode: true RMS.

5.3.1.2 Procedure

- 1) For an E-UTRA BS declared to be capable of single carrier operation only, set the BS transmission at manufacturer's declared rated output power, $P_{\text{rated},c}$. Channel set-up shall be according to E-TM 1.1 in clause 6.1.1.1 in ETSI TS 136 141 [1].

For an E-UTRA BS declared to be capable of multi-carrier operation, set the Base Station to transmit according to E-TM1.1 on all carriers configured using the applicable test configuration and corresponding power setting specified in clauses 4.10 and 4.11 of ETSI TS 136 141 [1].

For a E-UTRA BS declared to be capable of NB-IoT in-band operation, start transmission according to E-TM1.1 with the NB-IoT PRB constructed according to N-TM, as specified in ETSI TS 136 141 [1], at manufacturer's declared rated output power.

For a E-UTRA BS declared to be capable of NB-IoT guard-band operation, start transmission according to E-TM1.1 with the NB-IoT PRB constructed according to N-TM, as specified in ETSI TS 136 141 [1], at manufacturer's declared rated output power.

For a NB-IoT BS declared to be capable of single carrier operation, start transmission according to N-TM, as specified in ETSI TS 136 141 [1], at manufacturer's declared rated output power.

For a NB-IoT BS declared to be capable of multi-carrier in contiguous spectrum operation in single band only, start transmission according to N-TM on all carriers configured using in the applicable test configuration and corresponding power setting specified in ETSI TS 136 141 [1], clauses 4.10 and 4.11.

For a E-UTRA and NB-IoT standalone BS declared to be capable of multi-carrier in contiguous spectrum operation in single band only, start transmission according to E-TM1.1 on all E-UTRA carriers and N-TM on all NB-IoT carriers configured using in the applicable test configuration and corresponding power setting specified in ETSI TS 136 141 [1], clauses 4.10 and 4.11.

- 2) Step the centre frequency of the measurement filter in contiguous steps and measure the emission within the specified frequency ranges with the specified measurement bandwidth. For BS operating in multiple bands or non-contiguous spectrum, the emission within the Inter RF Bandwidth or sub-block gap shall be measured using the specified measurement bandwidth from the closest Base Station RF Bandwidth edge or sub-block edge.
- 3) For E-UTRA, repeat the test with the channel set-up according to E-TM 1.2, as specified in ETSI TS 136 141 [1].

In addition, for a multi-band capable BS, the following step shall apply:

- 4) For multi-band capable BS and single band tests, repeat the steps above per involved band where single band test configurations and test models shall apply with no carrier activated in the other band. For multi-band capable BS with separate antenna connector, the antenna connector not being under test in case of single-band or multi-band test shall be terminated.

5.3.1.3 Test requirement

The results obtained shall be compared to the limits in clause 4.2.2.2 in order to prove compliance.

5.3.2 Adjacent Channel Leakage power Ratio (ACLR)

5.3.2.1 Initial conditions

Test environment: normal; see ETSI TS 136 141 [1], clause D.2.

RF channels to be tested for single-carrier: B, M and T; see clause 5.3.0.

Base Station RF Bandwidth positions to be tested for multi-carrier:

- B_{RFBW} , M_{RFBW} and T_{RFBW} in single-band operation; see clause 5.3.0.
- $B_{\text{RFBW}-T'_{\text{RFBW}}}$ and $B'_{\text{RFBW}-T_{\text{RFBW}}}$ in multi-band operation; see clause 5.3.0.

Test set-up:

- 1) Connect measurement device to the Base Station Antenna connector as shown in ETSI TS 136 141 [1], clause I.1.1.
- 2) The measurement device characteristics shall be:
 - measurement filter bandwidth: defined in clause 4.2.3.4;
 - detection mode: true RMS voltage or true average power.

- 3) For an E-UTRA BS declared to be capable of single carrier operation only, set the Base Station to transmit a signal according to E-TM1.1 in clause 6.1.1.1 ETSI TS 136 141 [1] at manufacturer's declared rated output power, $P_{\text{rated,c}}$. For an E-UTRA BS declared to be capable of multi-carrier operation, set the Base Station to transmit according to E-TM1.1 on all carriers configured using the applicable test configuration and corresponding power setting specified in ETSI TS 136 141 [1], clauses 4.10 and 4.11.

For a E-UTRA BS declared to be capable of NB-IoT in-band operation, start transmission according to E-TM1.1 with the NB-IoT PRB constructed according to N-TM, as described in ETSI TS 136 141 [1], at manufacturer's declared rated output power.

For a E-UTRA BS declared to be capable of NB-IoT guard-band operation, start transmission according to E-TM1.1 with the NB-IoT PRB constructed according to N-TM, as described in ETSI TS 136 141 [1], at manufacturer's declared rated output power.

For a NB-IoT BS declared to be capable of single carrier operation, start transmission according to N-TM, as described in ETSI TS 136 141 [1], at manufacturer's declared rated output power.

For a NB-IoT BS declared to be capable of multi-carrier in contiguous spectrum operation in single band only, start transmission according to N-TM on all carriers configured using in the applicable test configuration and corresponding power setting specified in ETSI TS 136 141 [1], clauses 4.10 and 4.11.

For a E-UTRA and NB-IoT standalone BS declared to be capable of multi-carrier in contiguous spectrum operation in single band only, start transmission according to E-TM1.1 on all E-UTRA carriers and N-TM on all NB-IoT carriers configured using in the applicable test configuration and corresponding power setting specified in ETSI TS 136 141 [1], clauses 4.10 and 4.11.

- 4) Set carrier frequency within the frequency band supported by BS.

5.3.2.2 Procedure

- 1) Measure Adjacent channel leakage power ratio for the frequency offsets both side of channel frequency as specified in table 4.2.3.4.1-1 (Paired spectrum case) or table 4.2.3.4.1-2 (Unpaired spectrum case) respectively. In multiple carrier case only offset frequencies below the lowest and above the highest carrier frequency transmitted shall be measured.
- 2) For the ACLR requirement applied inside sub-block gap for non-contiguous spectrum operation or inside Inter RF Bandwidth gap for multi-band operation:
 - a) Measure ACLR inside sub-block gap or Inter RF Bandwidth gap as specified in clause 4.2.3.4.1, if applicable.
 - b) For E-UTRA, measure CACLR inside sub-block gap or Inter RF Bandwidth gap as specified in clause 4.2.3.4.2, if applicable.
- 3) For E-UTRA, repeat the test with the channel set-up according to E-TM1.2 in ETSI TS 136 141 [1].

In addition, for a multi-band capable BS, the following step shall apply:

- 4) For multi-band capable BS and single band tests, repeat the steps above per involved band where single band test configurations and test models shall apply with no carrier activated in the other band. For multi-band capable BS with separate antenna connector, the antenna connector not being under test in case of single-band or multi-band test shall be terminated.

5.3.2.3 Test requirement

The results obtained shall be compared to the limits in clause 4.2.3.4 in order to prove compliance.

5.3.3 Transmitter spurious emissions

5.3.3.0 General

This test measures conducted spurious emission from the E-UTRA or NB-IoT BS transmitter antenna connector, while the transmitter is in operation.

For an E-UTRA additionally conforming to ETSI EN 301 908-18 [7], either the test suite of the present clause or the Transmitter spurious emissions test suite in clause 5.3.3 of ETSI EN 301 908-18 [7], can be equally applied, as listed in table 4.2.1-2.

5.3.3.1 Initial conditions

Test environment: normal; see ETSI TS 136 141 [1], clause D.2.

RF channels to be tested for single-carrier: B, M and T, see clause 5.3.0.

Base Station RF Bandwidth positions to be tested:

- B_{RFBW} , M_{RFBW} and T_{RFBW} in single-band operation; see clause 5.3.0.
- $B'_{\text{RFBW}-T'_{\text{RFBW}}}$ and $B'_{\text{RFBW}-T_{\text{RFBW}}}$ in multi-band operation; see clause 5.3.0.

Test set-up:

- 1) Connect the BS antenna connector to a measurement receiver according to ETSI TS 136 141 [1], clause I.1.1 using an attenuator or a directional coupler if necessary.
- 2) Measurements shall use a measurement bandwidth in accordance to the conditions in ETSI TS 136 104 [4], clause 6.6.4.
- 3) Detection mode: true RMS.
- 4) For a BS declared to be capable of single carrier operation only, configure the BS with transmitters active at their maximum output power.

For a BS declared to be capable of multi-carrier operation, set the Base Station to transmit according to E-TM1.1 on all carriers configured as defined in the applicable test configuration in clause 4.10 of ETSI TS 136 141 [1].

5.3.3.2 Procedure

- 1) For a E-UTRA BS declared to be capable of single carrier operation only, set the BS to transmit a signal according to E-TM1.1, as specified in clause 6.1.1.1 of ETSI TS 136 141 [1], at manufacturer's declared rated output power.

For a E-UTRA BS declared to be capable of multi-carrier and/or CA operation, set the Base Station to transmit according to E-TM1.1 on all carriers configured using the applicable test configuration and corresponding power setting specified in of ETSI TS 136 141 [1], clauses 4.10 and 4.11.

For a E-UTRA BS declared to be capable of NB-IoT in-band operation, start transmission according to E-TM1.1 with the NB-IoT PRB constructed according to N-TM, as specified in of ETSI TS 136 141 [1], at manufacturer's declared rated output power.

For a E-UTRA BS declared to be capable of NB-IoT guard-band operation, start transmission according to E-TM1.1 with the NB-IoT PRB constructed according to N-TM, as specified in of ETSI TS 136 141 [1], at manufacturer's declared rated output power.

For a NB-IoT BS declared to be capable of single carrier operation, start transmission according to N-TM, as specified in of ETSI TS 136 141 [1], at manufacturer's declared rated output power.

For a NB-IoT BS declared to be capable of multi-carrier in contiguous spectrum operation in single band only, start transmission according to N-TM on all carriers configured using in the applicable test configuration and corresponding power setting specified in of ETSI TS 136 141 [1], clauses 4.10 and 4.11.

For a E-UTRA and NB-IoT standalone BS declared to be capable of multi-carrier in contiguous spectrum operation in single band only, start transmission according to E-TM1.1 on all E-UTRA carriers and N-TM on all NB-IoT carriers configured using in the applicable test configuration and corresponding power setting specified in of ETSI TS 136 141 [1], clauses 4.10 and 4.11.

- 2) Measure the emission at the specified frequencies with specified measurement bandwidth and note that the measured value does not exceed the specified value.

In addition, for a multi-band capable BS, the following step shall apply:

- 3) For multi-band capable BS and single band tests, repeat the steps above per involved band where single band test conditions and test models shall apply with no carrier activated in the other band. For multi-band capable BS with separate antenna connector, the antenna connector not being under test in case of SBT and MBT shall be terminated.

5.3.3.3 Test requirements

The results obtained shall be compared to the limits in clause 4.2.4.2 in order to prove compliance.

5.3.4 Base Station maximum output power

5.3.4.0 General

For an E-UTRA BS additionally conforming to ETSI EN 301 908-18 [7], either the test suite of the present clause or the Base Station maximum output power test suite in clause 5.3.4 of ETSI EN 301 908-18 [7] can be equally applied, as listed in table 4.2.1-2.

5.3.4.1 Initial conditions

Test environment: normal; see ETSI TS 136 141 [1], clause D.2.

RF channels to be tested for single-carrier: B, M and T, see clause 5.3.0.

Base Station RF Bandwidth positions to be tested for multi-carrier:

- B_{RFBW} , M_{RFBW} and T_{RFBW} in single-band operation, see clause 5.3.0.
- $B_{\text{RFBW-T'_{RFBW}}}$ and $B'_{\text{RFBW-T_{RFBW}}}$ in multi-band operation, see clause 5.3.0.

In addition, on one RF channel or Base Station RF Bandwidth position only, the test shall be performed under extreme power supply as defined in ETSI TS 136 141 [1], clause D.5.

NOTE: Tests under extreme power supply also test extreme temperature; see ETSI TS 136 141 [1], clause D.3.

Test set-up:

- 1) Connect the power measuring equipment to the Base Station antenna connector as shown in ETSI TS 136 141 [1], clause I.1.1.

5.3.4.2 Procedure

- 1) For an E-UTRA BS declared to be capable of single carrier operation only, set the Base Station to transmit a signal according to E-TM1.1 in clause 6.1.1.1 of ETSI TS 136 141 [1].

For an E-UTRA BS declared to be capable of multi-carrier operation, set the Base Station to transmit according to E-TM1.1 on all carriers configured using the applicable test configuration and corresponding power settings specified in ETSI TS 136 141 [1], clauses 4.10 and 4.11.

For an E-UTRA BS declared to be capable of NB-IoT in-band operation, start transmission according to E-TM1.1 with the NB-IoT PRB constructed according to N-TM at manufacturer's declared rated output power using the applicable test configuration and corresponding power setting specified in ETSI TS 136 141 [1], clauses 4.10 and 4.11.

For an E-UTRA BS declared to be capable of NB-IoT guard-band operation, start transmission according to E-TM1.1 with the NB-IoT PRB constructed according to N-TM at manufacturer's declared rated output power using the applicable test configuration and corresponding power setting specified in ETSI TS 136 141 [1], clauses 4.10 and 4.11.

For a NB-IoT BS declared to be capable of single carrier operation, start transmission according to N-TM as specified in ETSI TS 136 141 [1], at manufacturer's declared rated output power.

For a NB-IoT BS declared to be capable of multi-carrier operation, set the Base Station to transmit according to N-TM on all carriers configured using in the applicable test configuration and corresponding power setting specified in ETSI TS 136 141 [1], clauses 4.10 and 4.11.

For an E-UTRA and NB-IoT standalone BS declared to be capable of multi-carrier operation, start transmission according to E-TM1.1 on all E-UTRA carriers and N-TM on all NB-IoT carriers configured using in the applicable test configuration and corresponding power setting specified in ETSI TS 136 141 [1], clauses 4.10 and 4.11.

- 2) Measure the mean power for each carrier at the antenna connector.

In addition, for a multi-band capable BS, the following step shall apply:

- 3) For multi-band capable BS and single band tests, repeat the steps above per involved band where single band test configurations and test models shall apply with no carrier activated in the other band. For multi-band capable BS with separate antenna connector, the antenna connector not being under test in case of single-band or multi-band test shall be terminated.

5.3.4.3 Test requirement

The results obtained shall be compared to the limits in clause 4.2.5.2 in order to prove compliance.

5.3.5 Transmitter intermodulation

5.3.5.0 General

For an E-UTRA BS additionally conforming to ETSI EN 301 908-18 [7], either the test suite of the present clause or the Transmitter intermodulation test suite in clause 5.3.5 of ETSI EN 301 908-18 [7] can be equally applied, as listed in table 4.2.1-2.

5.3.5.1 Initial conditions

Test environment: normal; see ETSI TS 136 141 [1], clause D.2.

RF channels to be tested for single-carrier: B, M and T, see clause 5.3.0.

Base Station RF Bandwidth position to be tested for multi-carrier: B_{RFBW} , M_{RFBW} and T_{RFBW} ; see clause 5.3.0. The wanted signal channel bandwidth BW_{Channel} shall be the maximum channel bandwidth supported by the Base Station.

Test set-up:

- 1) Connect the signal analyser to the Base Station Antenna connector as shown in ETSI TS 136 141 [1], clause I.1.2.

5.3.5.2 Procedures

- 1) For an E-UTRA BS declared to be capable of single carrier operation only, set the BS to transmit according to E-TM1.1 in clause 6.1.1.1 of ETSI TS 136 141 [1] at manufacturer's declared rated output power, $P_{\text{rated,c}}$.

For an E-UTRA BS declared to be capable of multi-carrier operation, set the Base Station to transmit according to E-TM1.1 on all carriers configured using the applicable test configuration and corresponding power setting specified in clauses 4.10 and 4.11 of ETSI TS 136 141 [1].

For an E-UTRA BS declared to be capable of NB-IoT in-band operation, start transmission according to E-TM1.1 with the NB-IoT PRB constructed according to N-TM at manufacturer's declared rated output power using the applicable test configuration and corresponding power setting specified in ETSI TS 136 141 [1], clauses 4.10 and 4.11.

For an E-UTRA BS declared to be capable of NB-IoT guard-band operation, start transmission according to E-TM1.1 with the NB-IoT PRB constructed according to N-TM at manufacturer's declared rated output power using the applicable test configuration and corresponding power setting specified in ETSI TS 136 141 [1], clauses 4.10 and 4.11.

For a NB-IoT BS declared to be capable of single carrier operation, start transmission according to N-TM, as specified in ETSI TS 136 141 [1], at manufacturer's declared rated output power.

For a NB-IoT BS declared to be capable of multi-carrier operation, set the Base Station to transmit according to N-TM on all carriers configured using in the applicable test configuration and corresponding power setting specified in ETSI TS 136 141 [1], clauses 4.10 and 4.11.

For an E-UTRA and NB-IoT standalone BS declared to be capable of multi-carrier operation, start transmission according to E-TM1.1 on all E-UTRA carriers and N-TM on all NB-IoT carriers configured using in the applicable test configuration and corresponding power setting specified in ETSI TS 136 141 [1], clauses 4.10 and 4.11.

- 2) Generate the interfering signal according to E-TM1.1 in ETSI TS 136 141 [1], with 5 MHz channel bandwidth and a centre frequency offset according to the conditions of table 4.2.6.2-1 but exclude interfering frequencies that are outside of the allocated downlink operating band or interfering frequencies that are not completely within the sub-block gap or within the Inter RF Bandwidth gap.
- 3) Adjust ATT1 so that level of the E-UTRA interfering signal is as defined in clause 4.2.6.2.
- 4) Perform the unwanted emission tests as specified in clauses 5.3.1 and 5.3.2, for all third and fifth order intermodulation products which appear in the frequency ranges defined in clauses 5.3.1 and 5.3.2. The width of the intermodulation products shall be taken into account.
- 5) Perform the Transmitter spurious emissions test as specified in clause 5.3.3, for all third and fifth order intermodulation products which appear in the frequency ranges defined in clause 5.3.3. The width of the intermodulation products shall be taken into account.
- 6) Verify that the emission level does not exceed the required level with the exception of interfering signal frequencies.
- 7) Repeat the test for the remaining interfering signal centre frequency offsets according to the conditions of table 4.2.6.2-1.

In addition, for a multi-band capable BS, the following step shall apply:

- 8) For multi-band capable BS and single band tests, repeat the steps above per involved band where single band test configurations and test models shall apply with no carrier activated in the other band. For multi-band capable BS with separate antenna connector, the antenna connector not being under test shall be terminated.

NOTE: The third order intermodulation products are centred at $2F1 \pm F2$ and $2F2 \pm F1$. The fifth order intermodulation products are centred at $3F1 \pm 2F2$, $3F2 \pm 2F1$, $4F1 \pm F2$, and $4F2 \pm F1$ where $F1$ represents the wanted signal centre frequency or centre frequency of each sub-block and $F2$ represents the interfering signal centre frequency.

The widths of intermodulation products are:

- $(n \times BW_{F1} + m \times 5 \text{ MHz})$ for the $nF1 \pm mF2$ products;
- $(n \times 5 \text{ MHz} + m \times BW_{F1})$ for the $nF2 \pm mF1$ products.

where BW_{F1} represents the wanted signal RF bandwidth, or channel bandwidth in case of single carrier, or sub-block bandwidth.

5.3.5.3 Test requirement

The results obtained shall be compared to the limits in clause 4.2.6.2 in order to prove compliance.

5.3.6 Receiver spurious emissions

5.3.6.0 General

For an E-UTRA BS additionally conforming to ETSI EN 301 908-18 [7], either the test suite of the present clause or the Receiver spurious emissions test suite in clause 5.3.6 of ETSI EN 301 908-18 [7] can be equally applied, as listed in table 4.2.1-2.

5.3.6.1 Initial conditions

Test environment: normal; see ETSI TS 136 141 [1], clause D.2.

RF channels to be tested for single-carrier: M, see clause 5.3.0.

Base Station RF Bandwidth position to be tested for multi-carrier:

- M_{RFBW} in single-band operation; see clause 5.3.0.
- $B_{RFBW-T'_{RFBW}}$ and $B'_{RFBW-T_{RFBW}}$ in multi-band operation; see clause 5.3.0.

Test set-up:

- 1) Connect a measurement receiver to the BS antenna connector as shown in ETSI TS 136 141 [1], clause I.2.6.
- 2) Enable the BS receiver.
- 3) Terminate the BS TX antenna connector as shown in ETSI TS 136 141 [1], clause I.2.6.

5.3.6.2 Procedure

- 1) For an E-UTRA FDD BS declared to be capable of single carrier operation only, start BS transmission according to E-TM 1.1 in clause 6.1.1.1 of ETSI TS 136 141 [1] at manufacturer's declared rated output power, $P_{\text{rated,c}}$.

For an E-UTRA FDD BS declared to be capable of multi-carrier and/or CA operation, set the BS to transmit according to E-TM 1.1 on all carriers configured using the applicable test configuration and corresponding power setting specified in clauses 4.10 and 4.11 of ETSI TS 136 141 [1].

For E-UTRA BS declared to be capable of NB-IoT in-band or guard band operation single carrier operation only, start BS transmission according to E-TM 1.1. and N-TM, as specified in ETSI TS 136 141 [1], at manufacturer's declared rated output power.

For a E-UTRA BS declared to be capable of NB-IoT in-band or guard band operation multi-carrier, set the BS to transmit according to E-TM 1.1 on all E-UTRA carriers and to N-TM on all NB-IoT carriers configured using the applicable test configuration and corresponding power setting specified in ETSI TS 136 141 [1], clauses 4.10 and 4.11.

For a BS declared to be capable of NB-IoT standalone single carrier operation only, start BS transmission according to N-TM, as specified in ETSI TS 136 141 [1], at manufacturer's declared rated output power.

For a BS declared to be capable of NB-IoT standalone multi-carrier operation, set the BS to transmit according to N-TM on all carriers configured using the applicable test configuration and corresponding power setting specified in ETSI TS 136 141 [1], clauses 4.10 and 4.11.

For a E-UTRA and NB-IoT standalone BS, set the BS to transmit according to E-TM 1.1 on all E-UTRA carriers and according to N-TM on all NB-IoT carriers configured using the applicable test configuration and corresponding power setting specified in ETSI TS 136 141 [1], clauses 4.10 and 4.11.

- 2) Set measurement equipment parameters as specified in table 4.2.7.2-1.
- 3) Measure the spurious emissions over each frequency range described in clause 4.2.7.2.
- 4) Repeat the test for the Rx port(s), which was(were) terminated.

In addition, for a multi-band capable BS, the following step shall apply:

- 5) For multi-band capable BS and single band tests, repeat the steps above per involved band where single band test configurations and test models shall apply with no carrier activated in the other band. For multi-band capable BS with separate antenna connector, the antenna connector not being under test in case of single-band or multi-band test shall be terminated.

5.3.6.3 Test requirement

The results obtained shall be compared to the limits in clause 4.2.7.2 in order to prove compliance.

5.3.7 Blocking characteristics

5.3.7.0 General

For an E-UTRA BS additionally conforming to ETSI EN 301 908-18 [7], either the test suite of the present clause or the In-band and Out-of-band blocking test suites in clauses 5.3.7 and 5.3.8 of ETSI EN 301 908-18 [7] can be equally applied, as listed in table 4.2.1-2.

5.3.7.1 Initial conditions

Test environment: normal; see ETSI TS 136 141 [1], clause D.2.

RF channels to be tested for single-carrier: M see clause 5.3.0.

Base Station RF Bandwidth position to be tested for multi-carrier:

- M_{RFBW} , see clause 5.3.0.
- $B_{\text{RFBW-T}'_{\text{RFBW}}}$ and $B'_{\text{RFBW-T}_{\text{RFBW}}}$ in multi-band operation; see clause 5.3.0.

In addition, in multi-band operation:

- for $B_{\text{RFBW-T}'_{\text{RFBW}}}$, out-of-band blocking testing above the highest operating band may be omitted;
- for $B'_{\text{RFBW-T}_{\text{RFBW}}}$, out-of-band blocking testing below the lowest operating band may be omitted.

Test set-up:

The BS shall be configured to operate as close to the centre of the operating band (see table 1-1) as possible.

Channel bandwidths to be tested:

In the frequency range $(F_{\text{UL_low}} - 20)$ MHz to $(F_{\text{UL_high}} + 20)$ MHz the requirement shall be tested with the lowest and the highest bandwidth supported by the BS.

In the frequency ranges 1 MHz to $(F_{\text{UL_low}} - 20)$ MHz and $(F_{\text{UL_high}} + 20)$ MHz to 12 750 MHz the requirement shall be tested only with the lowest bandwidth supported by the BS.

- 1) Connect the signal generator for the wanted signal and the signal generator for the interfering signal to the antenna connector of one RX port according to as shown in ETSI TS 136 141 [1], clause I.2.5.
- 2) Terminate any other RX port not under test.
- 3) Start to transmit according to reference measurement channel as shown in ETSI TS 136 141 [1], clause A.1 to the BS under test. The level of the wanted signal measured at the BS antenna connector shall be set to the level specified in clause 4.2.8.2.

5.3.7.2 Procedure

For E-UTRA and E-UTRA with NB-IoT in-band or guard band BS:

- 1) For E-UTRA FDD BS capable of single carrier operation only, start BS transmission according to E-TM 1.1 in clause 6.1.1.1 of ETSI TS 136 141 [1] at manufacturer's declared rated output power, $P_{\text{rated,c}}$.

For a E-UTRA FDD BS declared to be capable of multi-carrier and/or CA operation, set the BS to transmit according to E-TM 1.1 on all carriers configured using the applicable test configuration and corresponding power setting specified in clauses 4.10 and 4.11 of ETSI TS 136 141 [1].

For BS declared to be capable of NB-IoT in-band or guard band operation single carrier operation only, start BS transmission according to E-TM 1.1 and N-TM, as described in ETSI TS 136 141 [1], at manufacturer's declared rated output power.

For a BS declared to be capable of NB-IoT in-band or guard band operation multi-carrier, set the BS to transmit according to E-TM 1.1 on all E-UTRA carriers and to N-TM on all NB-IoT carriers configured using the applicable test configuration and corresponding power setting specified in ETSI TS 136 141 [1], clauses 4.10 and 4.11.

The transmitter may be turned off for the out-of-band blocker tests when the frequency of the blocker is such that no IM2 or IM3 products fall inside the bandwidth of the wanted signal.

- 2) Adjust the signal generators to the type of interfering signals, levels and the frequency offsets as specified in tables 4.2.8.2-1, 4.2.8.2-4 for E-UTRA Wide Area BS, in tables 4.2.8.2-2 and 4.2.8.2-4 for E-UTRA Local Area BS, in tables 4.2.8.2-3 and 4.2.8.2-4 for E-UTRA Home BS, in table 4.2.8.2-5 and 4.2.8.2-4 for E-UTRA Medium Range BS and in tables 4.2.8.2-7 and 4.2.8.2-9 for NB-IoT in-band/guard band operation BS. The E-UTRA interfering signal shall be swept with a step size of 1 MHz starting from the minimum offset to the channel edges of the wanted signal as specified in table 4.2.8.2-4. The CW interfering signal shall be swept with a step size of 1 MHz within the range specified in table 4.2.8.2-1 for E-UTRA Wide Area BS, in table 4.2.8.2-2 for E-UTRA Local Area BS, in table 4.2.8.2-3 for E-UTRA Home BS, in table 4.2.8.2-5 for E-UTRA Medium Range and in table 4.2.8.2-7 for NB-IoT in-band/guard band operation BS.
- 3) Measure the E-UTRA throughput of the wanted signal at the BS receiver according to ETSI TS 136 141 [1], annex E, for multi-carrier operation the throughput shall be measured for relevant carriers specified by the test configuration in ETSI TS 136 141 [1], clause 4.10.

For BS declared to be capable of NB-IoT in-band or guard band operation, measure the NB-IoT throughput of the wanted signal at the BS receiver according to annex E, for multi-carrier the throughput shall be measured for relevant carriers specified by the test configuration specified in ETSI TS 136 141 [1], clauses 4.10 and 4.11.

- 4) Interchange the connections of the BS RX ports and repeat the measurements according to steps 1) to 3).

In addition, for a multi-band capable BS with separate antenna connectors, the following steps shall apply:

- 5) For single band tests, repeat the steps above per involved band where single band test configurations and test models shall apply with no carrier activated in the other band.
- 6) The interfering signal shall first be applied on the same port as the wanted signal. The test shall be repeated with the interfering signal applied on the other port (if any) mapped to the same receiver as the wanted signal. Any antenna connector with no signal applied in case of single-band or multi-band test shall be terminated.
- 7) Repeat step 6) with the wanted signal for the other band(s) applied on the respective port(s).

For NB-IoT standalone BS:

- 1) For BS declared to be capable of NB-IoT standalone single carrier only, start BS transmission according to N-TM, as specified in ETSI TS 136 141 [1], at manufacturer's declared rated output power.

For a BS declared to be capable of NB-IoT multi-carrier, set the BS to transmit according to N-TM on all carriers configured using the applicable test configuration and corresponding power setting specified in ETSI TS 136 141 [1], clauses 4.10 and 4.11.

The transmitter may be turned off for the out-of-band blocker tests when the frequency of the blocker is such that no IM2 or IM3 products fall inside the bandwidth of the wanted signal.

- 2) Adjust the signal generators to the type of interfering signals, levels and the frequency offsets as specified in tables 4.2.8.2-6 and 4.2.8.2-8. The E-UTRA interfering signal shall be swept with a step size of 1 MHz starting from the minimum offset to the channel edges of the wanted signal as specified in table 4.2.8.2-8. The CW interfering signal shall be swept with a step size of 1 MHz within the range specified in table 4.2.8.2-6.
- 3) Measure the NB-IoT throughput of the wanted signal at the BS receiver according to annex E, for multi-carrier the throughput shall be measured for relevant carriers specified by the test configuration specified in ETSI TS 136 141 [1], clauses 4.10 and 4.11.
- 4) Interchange the connections of the BS Rx ports and repeat the measurements according to steps 1) to 3).

For E-UTRA and NB-IoT standalone BS:

- 1) Set the BS to transmit according to E-TM 1.1 on all E-UTRA carriers and according to N-TM on all NB-IoT carriers configured using the applicable test configuration and corresponding power setting specified in ETSI TS 136 141 [1], clauses 4.10 and 4.11.

The transmitter may be turned off for the out-of-band blocker tests when the frequency of the blocker is such that no IM2 or IM3 products fall inside the bandwidth of the wanted signal.

- 2) a) On the side where E-UTRA signal is positioned:

Adjust the signal generators to the type of interfering signals, levels and the frequency offsets as specified in tables 4.2.8.2-1 and 4.2.8.2-4. The E-UTRA interfering signal shall be swept with a step size of 1 MHz starting from the minimum offset to the channel edges of the wanted signal as specified in table 4.2.8.2-4. The CW interfering signal shall be swept with a step size of 1 MHz within the range specified in table 4.2.8.2-1.

- b) On the side where NB-IoT signal is positioned:

Adjust the signal generators to the type of interfering signals, levels and the frequency offsets as specified in tables 4.2.8.2-6 and 4.2.8.2-8. The E-UTRA interfering signal shall be swept with a step size of 1 MHz starting from the minimum offset to the channel edges of the wanted signal as specified in table 4.2.8.2-8. The CW interfering signal shall be swept with a step size of 1 MHz within the range specified in table 4.2.8.2-6.

- 3) Measure the E-UTRA throughput of the E-UTRA wanted signal and the NB-IoT throughput of the NB-IoT wanted signal at the BS receiver according to annex E, for multi-carrier operation the throughput shall be measured for relevant carriers specified by the test configuration specified in ETSI TS 136 141 [1], clauses 4.10 and 4.11.
- 4) Interchange the connections of the BS Rx ports and repeat the measurements according to steps 1) to 3).

5.3.7.3 Test requirement

For each measured E-UTRA carrier, the results obtained shall be compared to the limits in clause 4.2.8.2 in order to prove compliance.

5.3.8 Receiver intermodulation characteristics

5.3.8.0 General

For an E-UTRA BS additionally conforming to ETSI EN 301 908-18 [7], either the test suite of the present clause or the Receiver intermodulation test suite in clause 5.3.9 of ETSI EN 301 908-18 [7] can be equally applied, as listed in table 4.2.1-2.

5.3.8.1 Initial conditions

Test environment: normal; see ETSI TS 136 141 [1], clause D.2.

RF channels to be tested for single-carrier: B, M and T, see clause 5.3.0.

Base Station RF Bandwidth position to be tested for multi-carrier:

- B_{RFBW} and T_{RFBW} ; see clause 5.3.0.
- $B_{\text{RFBW}-T_{\text{RFBW}}}$ and $B'_{\text{RFBW}-T_{\text{RFBW}}}$ in multi-band operation; see clause 5.3.0.

Test set-up:

- 1) Set-up the measurement system as shown in ETSI TS 136 141 [1], clause I.2.7.

5.3.8.2 Procedures

For E-UTRA and E-UTRA with NB-IoT in-band or guard band operation:

- 1) Generate the wanted signal using the applicable test configuration specified in clauses 4.10 and 4.11 of ETSI TS 136 141 [1], and adjust the signal level to the BS under test to the level specified in table 4.2.9.2-1.

For BS declared to be capable of NB-IoT in-band or guard band operation, generate the NB-IoT wanted signal using the applicable test configuration specified in ETSI TS 136 141 [1], clauses 4.10 and 4.11 and adjust the signal level to the BS under test to the level specified in table 4.2.9.2-7 or table 4.2.9.2-8.

- 2) Adjust the signal generators to the type of interfering signals, levels and the frequency offsets as specified in table 4.2.9.2-1 and table 4.2.9.2-2 for intermodulation requirement, table 4.2.9.2-3 for E-UTRA Wide Area BS narrowband intermodulation requirement, table 4.2.9.2-6 for E-UTRA Medium Range BS narrowband intermodulation requirement, table 4.2.9.2-4 for Local Area BS narrowband intermodulation requirement and table 4.2.9.2-5 for Home BS narrowband intermodulation requirement.
- 3) Measure the E-UTRA throughput according to ETSI TS 136 141 [1], annex E, for multi-carrier operation the throughput shall be measured for relevant carriers specified by the test configuration in ETSI TS 136 141 [1], clauses 4.10 and 4.11.

For BS declared to be capable of NB-IoT in-band or guard band operation, generate the NB-IoT wanted signal using the applicable test configuration specified in ETSI TS 136 141 [1], clauses 4.10 and 4.11 and adjust the signal level to the BS under test to the level specified in table 4.2.9.2-7 or table 4.2.9.2-8.

- 4) Repeat the test for the port(s) which was(were) terminated.

In addition, for a multi-band capable BS with separate antenna connectors, the following steps shall apply:

- 5) For single band tests, repeat the steps above per involved band where single band test configurations shall apply with no carrier activated in the other band.
- 6) The interfering signal shall first be applied on the same port as the wanted signal. The test shall be repeated with the interfering signal applied on the other port (if any) mapped to the same receiver as the wanted signal. Any antenna connector with no signal applied in case of single-band or multi-band test shall be terminated.
- 7) Repeat step 6) with the wanted signal for the other band(s) applied on the respective port(s).

For NB-IoT standalone operation:

- 1) Generate the NB-IoT wanted signal using the applicable test configuration specified in ETSI TS 136 141 [1], clauses 4.10 and 4.11 and adjust the signal level to the BS under test to the level specified in table 4.2.9.2-9.
- 2) Adjust the signal generators to the type of interfering signals, levels and the frequency offsets as specified in table 4.2.9.2-10 for intermodulation requirement and table 4.2.9.2-13 for narrowband intermodulation requirement.
- 3) Adjust the signal generators to obtain the specified level of interfering signal at the BS input.
- 4) Measure the NB-IoT throughput according to annex E in ETSI TS 136 141 [1], for multi-carrier the throughput shall be measured for relevant carriers specified by the test configuration specified in ETSI TS 136 141 [1], clauses 4.10 and 4.11.
- 5) Repeat the test for the port(s) which was (were) terminated.

For E-UTRA and NB-IoT standalone BS:

- 1) Generate the E-UTRA wanted signal using the applicable test configuration specified in ETSI TS 136 141 [1], clauses 4.10 and 4.11 and adjust the signal level to the BS under test to the level specified in table 4.2.9.2-1.

Generate the NB-IoT wanted signal using the applicable test configuration specified in ETSI TS 136 141 [1], clauses 4.10 and 4.11 and adjust the signal level to the BS under test to the level specified in table 4.2.9.2-9.

- 2) a) On the side where E-UTRA signal is positioned:
Adjust the signal generators to the type of interfering signals, levels and the frequency offsets as specified in table 4.2.9.2-2 for intermodulation requirement and tables 4.2.9.2-3 to 4.2.9.2-5 and table 4.2.9.2-6 for narrowband intermodulation requirement.
- b) On the side where NB-IoT signal is positioned:
Adjust the signal generators to the type of interfering signals, levels and the frequency offsets as specified in table 4.2.9.2-10 for intermodulation requirement and table 4.2.9.2-13 for narrowband intermodulation requirement.
- 3) Adjust the signal generators to obtain the specified level of interfering signal at the BS input.

- 4) Measure the E-UTRA throughput according to annex E, for multi-carrier and/or CA operation the throughput shall be measured for relevant carriers specified by the test configuration specified in ETSI TS 136 141 [1], clauses 4.10 and 4.11.

Measure the NB-IoT throughput according to annex E, for multi-carrier the throughput shall be measured for relevant carriers specified by the test configuration specified in ETSI TS 136 141 [1], clauses 4.10 and 4.11.

- 5) Repeat the test for the port(s) which was (were) terminated.

5.3.8.3 Test requirement

For each measured E-UTRA carrier, the results obtained shall be compared to the limits in clause 4.2.9.2 in order to prove compliance.

5.3.9 Adjacent Channel Selectivity (ACS) and narrow-band blocking

5.3.9.0 General

For an E-UTRA BS additionally conforming to ETSI EN 301 908-18 [7], either the test suite of the present clause or the Narrowband blocking test suite in clause 5.3.10 of ETSI EN 301 908-18 [7] can be equally applied, as listed in table 4.2.1-2.

5.3.9.1 Initial conditions

Test environment: normal; see ETSI TS 136 141 [1], clause D.2.

RF channels to be tested for single-carrier: B, M and T, see clause 5.3.0.

Base Station RF Bandwidth position to be tested for multi-carrier:

- M_{RFBW} in single-band operation; see clause 5.3.0.
- $B_{\text{RFBW-T}'_{\text{RFBW}}}$ and $B'_{\text{RFBW-T}}_{\text{RFBW}}$ in multi-band operation; see clause 5.3.0.

Test set-up:

- 1) Set-up the measurement system as shown in ETSI TS 136 141 [1], clause I.2.4.

5.3.9.2 Procedure for Adjacent Channel Selectivity

- 1) Generate the E-UTRA wanted signal and using the applicable test configuration specified in clauses 4.10 and 4.11 of ETSI TS 136 141 [1] and adjust the input level to the Base Station under test to the level specified in table 4.2.10.2-3 for E-UTRA Wide Area BS, in table 4.2.10.2-6 for E-UTRA Medium Range BS, in table 4.2.10.2-4 for E-UTRA Local Area BS and in table 4.2.10.2-5 for E-UTRA Home BS.

For a BS declared to be capable of NB-IoT in-band or guard band operation,, generate the NB-IoT wanted signal using the applicable test configuration specified in ETSI TS 136 141 [1], clauses 4.10 and 4.11 and adjust the input level to the Base Station under test to the level specified in table 4.2.10.2-3A for NB-IoT in-band operation Wide Area BS and table 4.2.10.2-3B for NB-IoT in guard band operation Wide Area BS.

- 2) Set-up the interfering signal at the adjacent channel frequency and adjust the interfering signal level at the Base Station input to the level defined in table 4.2.10.2-3 for E-UTRA Wide Area BS, in table 4.2.10.2-6 for E-UTRA Medium Range BS, in table 4.2.10.2-4 for E-UTRA Local Area BS, in table 4.2.10.2-5 for E-UTRA Home BS, and in table 4.2.10.2-3A for NB-IoT in-band operation Wide Area BS and table 4.2.10.2-3B for NB-IoT in guard band operation Wide Area BS.
- 3) Measure the E-UTRA throughput according to ETSI TS 136 141 [1], annex E, for multi-carrier operation the throughput shall be measured for relevant carriers specified by the test configuration in ETSI TS 136 141 [1], clauses 4.10 and 4.11.

For a BS declared to be capable of NB-IoT in-band or guard band operation, measure the NB-IoT throughput according to annex E in ETSI TS 136 141 [1], for multi-carrier the throughput shall be measured for relevant carriers specified by the test configuration specified in in ETSI TS 136 141 [1], clauses 4.10 and 4.11.

- 4) Repeat the test for the port(s), which was(were) terminated.

In addition, for a multi-band capable BS with separate antenna connectors, the following steps shall apply:

- 5) For single band tests, repeat the steps above per involved band where single band test configurations shall apply with no carrier activated in the other band.

The interfering signal shall first be applied on the same port as the wanted signal. The test shall be repeated with the interfering signal applied on the other port (if any) mapped to the same receiver as the wanted signal. Any antenna connector with no signal applied in case of single-band or multi-band test shall be terminated.

- 6) Repeat step 5) with the wanted signal for the other band(s) applied on the respective port(s).

For NB-IoT standalone operation:

- 1) Generate the NB-IoT wanted signal using the applicable test configuration specified in ETSI TS 136 141 [1], clauses 4.10 and 4.11 and adjust the input level to the Base Station under test to the level specified in table 4.2.10.2-3C for NB-IoT standalone Wide Area BS.
- 2) Set-up the interfering signal at the adjacent channel frequency and adjust the interfering signal level at the Base Station input to the level defined in table 4.2.10.2-3C for NB-IoT standalone Wide Area BS.
- 3) Measure NB-IoT throughput according to annex E in ETSI TS 136 141 [1].
- 4) Repeat the test for the port(s), which was (were) terminated.

5.3.9.3 Procedure for narrow-band blocking

For E-UTRA and E-UTRA with NB-IoT in-band or guard band BS:

- 1) For FDD BS declared to be capable of single carrier operation only, start BS transmission according to E-TM1.1 in clause 6.1.1.1 of ETSI TS 136 141 [1] at manufacturer's declared rated output.

For a FDD BS declared to be capable of multi-carrier, set the BS to transmit according to E-TM 1.1 on all carriers configured using the applicable test configuration and corresponding power setting specified in clauses 4.10 and 4.11 of ETSI TS 136 141 [1].

For BS declared to be capable of NB-IoT in-band or guard band operation single carrier only, start BS transmission according to N-TM, as specified in ETSI TS 136 141 [1], at manufacturer's declared rated output power.

For a BS declared to be capable of NB-IoT multi-carrier, set the BS to transmit according to N-TM on all carriers configured using the applicable test configuration and corresponding power setting specified in ETSI TS 136 141 [1], clauses 4.10 and 4.11.

- 2) Generate the E-UTRA wanted signal using the applicable test configuration specified in ETSI TS 136 141 [1], clauses 4.10 and 4.11 and adjust the input level to the Base Station under test to the level specified in table 4.2.10.2-1.

For a BS declared to be capable of NB-IoT in-band or guard band operation, generate the NB-IoT wanted signal using the applicable test configuration specified in ETSI TS 136 141 [1], clauses 4.10 and 4.11 and adjust the input level to the Base Station under test to the level specified in table 4.2.10.2-1A for NB-IoT in-band operation and table 4.2.10.2-1B for NB-IoT guard band operation.

- 3) Adjust the interfering signal level at the Base Station input to the level defined in table 4.2.10.2-1 for E-UTRA, in table 4.2.10.2-1A for NB-IoT in-band operation and table 4.2.10.2-1B for NB-IoT guard band operation. Set-up and sweep the interfering RB centre frequency offset to the channel edge of the wanted signal according to table 4.2.10.2-2.

- 4) Measure the E-UTRA throughput according to ETSI TS 136 141 [1], annex E, for multi-carrier operation the throughput shall be measured for relevant carriers specified by the test configuration in ETSI TS 136 141 [1], clause 4.11.

For a BS declared to be capable of NB-IoT in-band or guard band operation, measure the NB-IoT throughput according to ETSI TS 136 141 [1], annex E, for multi-carrier the throughput shall be measured for relevant carriers specified by the test configuration specified in ETSI TS 136 141 [1], clauses 4.10 and 4.11.

- 5) Repeat the test for the port(s), which was(were) terminated.

In addition, for a multi-band capable BS with separate antenna connectors, the following steps shall apply:

- 6) For single band tests, repeat the steps above per involved band where single band test configurations and test models shall apply with no carrier activated in the other band.
- 7) The interfering signal shall first be applied on the same port as the wanted signal. The test shall be repeated with the interfering signal applied on the other port (if any) mapped to the same receiver as the wanted signal. Any antenna connector with no signal applied in case of single-band or multi-band test shall be terminated.
- 8) Repeat step 7) with the wanted signal for the other band(s) applied on the respective port(s).

For NB-IoT standalone BS:

- 1) For BS declared to be capable of NB-IoT standalone single carrier only, start BS transmission according to N-TM, as specified in ETSI TS 136 141 [1], at manufacturer's declared rated output power.

For a BS declared to be capable of NB-IoT multi-carrier, set the BS to transmit according to N-TM on all carriers configured using the applicable test configuration and corresponding power setting specified in ETSI TS 136 141 [1], clauses 4.10 and 4.11.

- 2) Generate the NB-IoT wanted signal using the applicable test configuration specified in ETSI TS 136 141 [1], clauses 4.10 and 4.11 and adjust the input level to the Base Station under test to the level specified in table 4.2.10.2-1C.
- 3) Adjust the interfering signal level at the Base Station input to the level defined in table 4.2.10.2-1C. Set-up and sweep the interfering RB centre frequency offset to the channel edge of the wanted signal according to table 4.2.10.2-2A.
- 4) Measure the NB-IoT throughput according to annex E, for multi-carrier the throughput shall be measured for relevant carriers specified by the test configuration specified in clauses 4.10 and 4.11.
- 5) Repeat the test for the port(s), which was (were) terminated.

For E-UTRA and NB-IoT standalone BS:

- 1) Set the BS to transmit according to E-TM 1.1 on all E-UTRA carriers and according to N-TM on all NB-IoT carriers configured using the applicable test configuration and corresponding power setting specified in ETSI TS 136 141 [1], clauses 4.10 and 4.11.
- 2) Generate the E-UTRA wanted signal using the applicable test configuration specified in ETSI TS 136 141 [1], clauses 4.10 and 4.11 and adjust the input level to the Base Station under test to the level specified in table 4.2.10.2-1.

Generate the NB-IoT wanted signal using the applicable test configuration specified in ETSI TS 136 141 [1], clauses 4.10 and 4.11 and adjust the input level to the Base Station under test to the level specified in table 4.2.10.2-1C.

- 3) a) On the side where E-UTRA signal is positioned:

Adjust the interfering signal level at the Base Station input to the level defined in table 4.2.10.2-1 for E-UTRA. Set-up and sweep the interfering RB centre frequency offset to the channel edge of the wanted signal according to table 4.2.10.2-2.

- b) On the side where NB-IoT signal is positioned:

Adjust the interfering signal level at the Base Station input to the level defined in table 4.2.10.2-1C. Set-up and sweep the interfering RB centre frequency offset to the channel edge of the wanted signal according to table 4.2.10.2-2A.

- 4) Measure the E-UTRA throughput and the NB-IoT throughput according to ETSI TS 136 141 [1] annex E, for multi-carrier the throughput shall be measured for relevant carriers specified by the test configuration specified in ETSI TS 136 141 [1], clauses 4.10 and 4.11.
- 5) Repeat the test for the port(s), which was (were) terminated.

5.3.9.4 Test requirement

For each measured E-UTRA carrier, the results obtained shall be compared to the limits in clause 4.2.10.2 in order to prove compliance.

5.3.10 Home BS output power for adjacent UTRA channel protection

5.3.10.1 Initial conditions

Test environment: normal; see ETSI TS 136 141 [1], clause D.2.

RF channels to be tested for single-carrier: M; see clause 5.3.0.

Test set-up:

- 1) Set-up the equipment as shown in ETSI TS 136 141 [1], clause I.1-4.
- 2) The Home BS is configured such that the adjacent channel is known to belong to another operator.

5.3.10.2 Procedure

- 1) Connect the combined downlink interfering signals (referred to as point D in figure I.1-4 of ETSI TS 136 141 [1]) to the dedicated measurement port (referred to as point 1 in figure I.1-4 of ETSI TS 136 141 [1]) if available, otherwise connect to point 2.
- 2) Configure the signal generator for co-channel interference to transmit AWGN over a bandwidth according to BW_{Config} centred on RF channel M.
- 3) Configure the signal generator for adjacent channel DL signal to transmit test model 1 in ETSI TS 125 141 [5] at the centre frequency equal to RF channel M + $BW_{Channel}/2 + 2,5$ MHz.
- 4) Switch on signal generators delivering co-channel and adjacent channel interferers, and adjust the ATT1 and ATT2 such that $CPICH \hat{E}_c = -80$ dBm and $I_{oh} = -50$ dBm.
- 5) Trigger the Home BS power adjustment mechanism.
- 6) Configure the Home BS to transmit a signal according to E-TM1.1 in clause 6.1.1.1 of ETSI TS 136 141 [1]. The signal shall be transmitted with the maximum allowed output power.
- 7) Measure Home BS output power, P_{out} , and check it is below the required value according to the $CPICH \hat{E}_c$ and I_{oh} values determined in step 4).
- 8) Repeat steps 3) to 7) with the frequency in step 3) set to RF channel M - $BW_{Channel}/2 - 2,5$ MHz.
- 9) Repeat steps 3) to 8) with different settings for ATT1 and ATT2 to arrive the $CPICH \hat{E}_c$ and I_{oh} pairs as specified in table 5.3.10.2-1.

Table 5.3.10.2-1: Test parameter settings

Test Case	CPICH \hat{E}_c (dBm)	I _{oh} (dBm)
2	-90	-60
3	-100	-70
4	-100	-50

5.3.10.3 Test requirement

The results obtained shall be compared to the limits in clause 4.2.11.2 in order to prove compliance.

5.3.11 Home BS output power for adjacent E-UTRA channel protection

5.3.11.1 Initial conditions

Test environment: normal; see ETSI TS 136 141 [1], clause D.2.

RF channels to be tested for single-carrier: M; see clause 5.3.0.

In addition, on one EARFCN only, the test shall be performed under extreme power supply as defined in clause D.5 of ETSI TS 136 141 [1].

NOTE: Tests under extreme power supply also test extreme temperature; see ETSI TS 136 141 [1], clause D.3.

Signal generators delivering co-channel and adjacent channel interferers are switched off.

Test set-up:

- 1) Set-up the equipment as shown as shown in ETSI TS 136 141 [1], figure I.1-4.
- 2) The Home BS is configured such that the adjacent channels need to be protected.

5.3.11.2 Procedure

- 1) Connect the combined downlink interfering signals (referred to as point D in figure I.1-4 of ETSI TS 136 141 [1]) to the dedicated measurement port (referred to as point 1 in figure I.1-4 of ETSI TS 136 141 [1]) if available, otherwise connect to point 2.
- 2) Configure the signal generator for co-channel interference to transmit AWGN over a bandwidth according to BW_{Config} centred on RF channel M.
- 3) Configure the signal generator for adjacent channel DL signal to transmit a signal according to E-TM1.1 in clause 6.1.1.1 in ETSI TS 136 141 [1] at the centre frequency equal to RF channel M + BW_{Channel} MHz.
- 4) Switch on signal generators delivering co-channel and adjacent channel interferers, and adjust the ATT1 and ATT2 such that $\text{CRS } \hat{E}_s = -65 - 10 \cdot \log_{10} \left(N_{RB}^{DL} \cdot N_{sc}^{RB} \right)$ dBm and $I_{oh} = -50$ dBm.
- 5) Trigger the Home BS power adjustment mechanism.
- 6) Configure the Home BS to transmit a signal according to E-TM1.1 in ETSI TS 136 141 [1]. The signal shall be transmitted with the maximum allowed output power.
- 7) Measure Home BS output power, P_{out} , and check it is below the required value according to the $\text{CRS } \hat{E}_s$ and I_{oh} values determined in step 4).
- 8) Repeat steps 3) to 7) with the frequency in step 3) set to RF channel M - BW_{Channel} MHz.
- 9) Repeat steps 3) to 8) with different settings for ATT1 and ATT2 to arrive the $\text{CRS } \hat{E}_s$ and I_{oh} pairs as specified in table 5.3.11.2-1.

Table 5.3.11.2-1: CRS \hat{E}_s and Ioh pairs

Test Case	CRS \hat{E}_s (dBm)	Ioh (dBm)
2	$-75 - 10 \cdot \log_{10} (N_{RB}^{DL} \cdot N_{sc}^{RB})$	-60
3	$-90 - 10 \cdot \log_{10} (N_{RB}^{DL} \cdot N_{sc}^{RB})$	-70
4	$-90 - 10 \cdot \log_{10} (N_{RB}^{DL} \cdot N_{sc}^{RB})$	-50

5.3.11.3 Test requirement

The results obtained shall be compared to the limits in clause 4.2.12.2 in order to prove compliance.

5.3.12 Home BS output power for co-channel E-UTRA protection

5.3.12.1 Initial conditions

Test environment: normal; see ETSI TS 136 141 [1], clause D.2.

RF channels to be tested for single-carrier: M; see clause 5.3.0.

In addition, on one EARFCN only, the test shall be performed under extreme power supply as defined in clause D.5 of ETSI TS 136 141 [1].

NOTE: Tests under extreme power supply also test extreme temperature; see ETSI TS 136 141 [1], clause D.3.

Signal generators delivering co-channel interferers are switched off.

Test set-up:

- 1) Set-up the equipment as shown in ETSI TS 136 141 [1], clause I.1-5, based on the option supported by Home BS.
- 2) The co-channel interference should be configured containing at least signals from a neighbouring Marco BS. For option 2 of table 4.2.13.2-1, additional signal generator needed to deliver the MUE UL signal.

5.3.12.2 Procedure

- 1) Connect the downlink co-channel interfering signals (referred to as point D in figure I.1-5 of ETSI TS 136 141 [1]) to the dedicated measurement port (referred to as point 1 in figure I.1-5 of ETSI TS 136 141 [1]) if available, otherwise connect to point 2. Specifically for option 2 of table 4.2.13.2-1, connect the UL interference to point 2 for UL receiving on the figure of I.1.5-b of ETSI TS 136 141 [1].
- 2) Configure the signal generator for co-channel interference to transmit AWGN over a bandwidth according to BW_{Config} centred on RF channel M.
- 3) Configure the X as 30 dB. Switch on signal generators delivering interferers, and adjust the ATT such that $CRS \hat{E}_s = -10 - 10 \cdot \log_{10} (N_{RB}^{DL} \cdot N_{sc}^{RB})$ dBm and $Ioh = -50$ dBm.
- 4) Trigger the Home BS power adjustment mechanism.
- 5) Configure the Home BS to transmit a signal according to E-TM1.1 in clause 6.1.1.1 of ETSI TS 136 141 [1]. The signal shall be transmitted with the maximum allowed output power.
- 6) Measure Home BS output power, P_{out} , and check it is below the required value according to the CRS \hat{E}_s and Ioh values determined in step 3). The value of Pmin for testing is -10 dBm.
- 7) Repeat steps 4) to 6) with different settings for ATT to arrive the input parameter pairs as specified in tables 5.3.12.2-1 or 5.3.12.2-2, basing the option of table 4.2.13.2-1 supported by the Home BS.

Table 5.3.12.2-1: CRS \hat{E}_c and loh pairs for option 1

Test Case	CRS \hat{E}_s (dBm)	loh (dBm)
1	$-20 - 10 \cdot \log_{10}(N_{RB}^{DL} \cdot N_{sc}^{RB})$	-60
2	$P_{min} - 30 - 10 \cdot \log_{10}(N_{RB}^{DL} \cdot N_{sc}^{RB})$	-70
3	$-90 - 10 \cdot \log_{10}(N_{RB}^{DL} \cdot N_{sc}^{RB})$	-50

Table 5.3.12.2-2: CRS \hat{E}_c , loh and lob pairs for option 2

Test Case	CRS \hat{E}_s (dBm)	loh (dBm)	lob (dBm)
1	$-20 - 10 \cdot \log_{10}(N_{RB}^{DL} \cdot N_{sc}^{RB})$	-60	-98
2	$P_{min} - 30 - 10 \cdot \log_{10}(N_{RB}^{DL} \cdot N_{sc}^{RB})$	-70	-98
3	$-90 - 10 \cdot \log_{10}(N_{RB}^{DL} \cdot N_{sc}^{RB})$	-50	-98

5.3.12.3 Test requirement

The results obtained shall be compared to the limits in clause 4.2.13.2 in order to prove compliance.

5.3.13 Reference sensitivity level

5.3.13.0 General

The test is set up according to clause I.2.1 in ETSI TS 136 141 [1] and performed without interfering signal power applied to the BS antenna connector. For duplex operation, the measurement configuration principle is indicated for one duplex branch in clause I.2.1 in ETSI TS 136 141 [1]. The reference point for signal power is at the input of the receiver (antenna connector).

5.3.13.1 Initial conditions

Test environment: normal; see ETSI TS 136 141 [1], clause D.2.

RF channels to be tested for single carrier: B, M and T; see clause 5.3.0.

The following additional tests shall be performed:

- 1) On each of B, M and T, the test shall be performed under extreme power supply as defined in clause D.5 of the ETSI TS 136 141 [1].

NOTE: Tests under extreme power supply also test extreme temperature; see ETSI TS 136 141 [1], clause D.3.

- 2) Connect the test equipment as shown in clause I.2.1 in ETSI TS 136 141 [1].

5.3.13.2 Procedure

- 1) a) For FDD BS start BS transmission according to E-TM 1.1, as specified in ETSI TS 136 141 [1], in clause 6.1.1.1, at manufacturer's declared rated output power, $P_{rated,c}$.
- b) For NB-IoT BS start BS transmission according to N-TM, as specified in ETSI TS 136 141 [1], at manufacturer's declared rated output power.
- 2) Set the test signal mean power as specified in table 4.2.14.2-1 for E-UTRA Wide Area BS, in table 4.2.14.2-2 for E-UTRA Local Area BS, in table 4.2.14.2-3 for E-UTRA Home BS, in table 4.2.14.2-4 for E-UTRA Medium Range BS, and in table 4.2.14.2-5 for NB-IoT Wide Area BS.
- 3) Measure the throughput according to annex E in ETSI TS 136 141 [1].
- 4) Repeat the measurement for the other RX port(s).

In addition, for a multi-band capable BS, the following step shall apply:

- 5) For multi-band capable BS and single band tests, repeat the steps above per involved band where single carrier test models shall apply with no carrier activated in the other band. For multi-band capable BS with separate antenna connector, the antenna connector not being under test shall be terminated.

5.3.13.3 Test requirement

The results obtained shall be compared to the limits in clause 4.2.14.2 in order to prove compliance.

5.3.14 Downlink channel access procedure

5.3.14.1 General

The test purpose is to verify the accuracy of the energy detection threshold, maximum channel occupancy time (MCOT) and minimum idle time under normal conditions for all band 46 transmitters in the BS.

5.3.14.2 Initial conditions

Test environment: normal; see ETSI TS 136 141 [1], clause D.2.

RF channels to be tested for single carrier: B, M and T; see clause 5.3.0.

Connect the signal analyser to the Base Station antenna connector as shown in ETSI TS 136 141 [1], clause I.4.

5.3.14.3 Procedure

MCOT and minimum idle time

- 1) Set the Base Station to transmit a signal according to E-TM 1.1 at manufacturer's declared rated output power with 20 MHz channel bandwidth. Channel Access Priority Class 3 parameters shall be selected, based on table 15.1.1-1 in ETSI TS 136 213 [9].
- 2) Measure the transmitter ON period during the continuous transmission (after the first channel access).
- 3) Measure the transmitter OFF period between two consecutive transmitter ON periods.
- 4) Verify minimum idle time as follows:
 - The transmitter OFF period between two consecutive transmitter ON periods shall not be less than 25 μ s.
- 5) Verify maximum channel occupancy time (MCOT) as follows:
 - a) The duration of each transmitter ON period continuous transmission shall not exceed the maximum channel occupancy time (MCOT) limit specified in clause 4.2.15.2.

Energy detection accuracy

- 6) Generate the interfering signal of AWGN with 20 MHz channel bandwidth at the same centre frequency as the tested channel. The interfering signal shall be at a level of $(-72 \text{ dBm} + 4 \text{ dB})/20 \text{ MHz}$. The Base Station shall stop transmission on the current operating channel and will not resume normal transmissions as long as the interference signal is present.
- 7) The step 6) is repeated multiple times considering the following sub-steps:
 - Interferer ON: if the interfering signal is present, the interfering signal should be present for 10 ms.
 - Interferer OFF: if the interfering signal is removed, the interfering signal should be absent for 10 ms.

The total number of interferer ON duration is assumed to be N and the total number of interferer OFF duration is assumed to be M. The value N, M and the sequence of interferer ON/OFF pattern shall be generated randomly for the test.

- 8) In the test, a counter is maintained with initial value set to 0 when the test starts.
- 9) For every 10 ms Interferer ON period, the counter is increased by 1 if there is either an ON/OFF transition or no transmission by the BS. To pass the test, the counter shall not be less than $N \times 0,9$.

5.3.14.4 Test requirements

The results obtained shall be compared to the limits in clause 4.2.15.2 in order to prove compliance.

5.3.15 Dynamic frequency selection (DFS)

The DFS test procedure specified in ETSI EN 301 893 [8], clause 5.4.8 shall apply.

5.3.16 Base Station output power (band 46)

The test procedures specified in ETSI EN 301 893 [8], clause 5.4.4 shall apply.

Following statements about how test procedures apply to an E-UTRA BS are necessary:

- The output power and power density of the transmitter shall be measured using a trigger so that only the Tx On pulse of the TDD signal is captured and measured, without averaging with Tx Off periods. The results shall represent the peak output power and peak power density of the TDD signal.
- RF channels to be tested shall be chosen according to ETSI EN 301 893 [8], Table 11, clause 5.3.2.

Annex A (informative): Relationship between the present document and the essential requirements of Directive 2014/53/EU

The present document has been prepared under the Commission's standardisation request C(2015) 5376 [i.1] final to provide one voluntary means of conforming to the essential requirements of Directive 2014/53/EU on the harmonisation of the laws of the Member States relating to the making available on the market of radio equipment and repealing Directive 1999/5/EC [i.2].

Once the present document is cited in the Official Journal of the European Union under that Directive, compliance with the normative clauses of the present document given in table A-1 confers, within the limits of the scope of the present document, a presumption of conformity with the corresponding essential requirements of that Directive, and associated EFTA regulations.

Table A-1: Relationship between the present document and the essential requirements of Directive 2014/53/EU

Harmonised Standard ETSI EN 301 908-14					
Requirement				Requirement Conditionality	
No	Description	Essential requirements of Directive	Clause(s) of the present document	U/C	Condition
1	Operating band unwanted emissions	3.2	4.2.2	U	
2	Adjacent Channel Leakage power Ratio (ACLR)	3.2	4.2.3	U	
3	Transmitter spurious emissions	3.2	4.2.4	U	
4	Base Station maximum output power	3.2	4.2.5	U	
5	Transmit intermodulation	3.2	4.2.6	U	
6	Receiver spurious emissions	3.2	4.2.7	U	
7	Blocking characteristics	3.2	4.2.8	U	
8	Receiver intermodulation characteristics	3.2	4.2.9	U	
9	Adjacent Channel Selectivity (ACS) and narrow-band blocking	3.2	4.2.10	U	
10	Home BS output power for adjacent UTRA channel protection	3.2	4.2.11	C	Applies to BS declared as Home Base Station
11	Home BS output power for adjacent E-UTRA channel protection	3.2	4.2.12	C	Applies to BS declared as Home Base Station
12	Home BS output power for co-channel E-UTRA protection	3.2	4.2.13	C	Applies to BS declared as Home Base Station
13	Reference sensitivity level	3.2	4.2.14	U	
14	Downlink channel access procedure	3.2	4.2.15	C	Applies to BS declared to support operation in band 46
15	Dynamic Frequency Selection (DFS)	3.2	4.2.16	C	Applies to BS declared to support operation in sub-bands 46b and 46c

Key to columns:

Requirement:

No A unique identifier for one row of the table which may be used to identify a requirement.

Description A textual reference to the requirement.

Essential requirements of Directive

Identification of article(s) defining the requirement in the Directive.

Clause(s) of the present document

Identification of clause(s) defining the requirement in the present document unless another document is referenced explicitly.

Requirement Conditionality:

U/C Indicates whether the requirement is unconditionally applicable (U) or is conditional upon the manufacturer's claimed functionality of the equipment (C).

Condition Explains the conditions when the requirement is or is not applicable for a requirement which is classified "conditional".

Presumption of conformity stays valid only as long as a reference to the present document is maintained in the list published in the Official Journal of the European Union. Users of the present document should consult frequently the latest list published in the Official Journal of the European Union.

Other Union legislation may be applicable to the product(s) falling within the scope of the present document.

Annex B (normative): Base Station configurations

B.1 Reception with multiple receiver antenna connectors, receiver diversity

For the tests in clause 5, the requirement shall apply at each receiver antenna connector for receivers with antenna diversity or in the case of multi-carrier reception with multiple receiver antenna connectors.

Receiver requirements are tested at the antenna connector, with the remaining receiver(s) disabled or their antenna connector(s) being terminated. If the manufacturer has declared the receiver paths to be equivalent, it is sufficient to apply the specified test signal at any one of the receiver antenna connectors.

For a multi-band BS, multi-band tests for blocking and intermodulation are performed with the interferer(s) applied to each antenna connector mapped to the receiver for the wanted signal(s), however only to one antenna at a time. Antenna connectors to which no signals are applied are terminated.

B.2 Duplexers

The requirements of the present document shall be met with a duplexer fitted, if a duplexer is supplied as part of the BS. If the duplexer is supplied as an option by the manufacturer, sufficient tests should be repeated with and without the duplexer fitted to verify that the BS meets the requirements of the present document in both cases.

The following tests shall be performed with the duplexer fitted, and without it fitted if this is an option:

- 1) clause 5.3.4, Base Station maximum output power, for the highest static power step only, if this is measured at the antenna connector;
- 2) clause 5.3.3, transmitter spurious emissions; outside the BS transmit band;
- 3) clause 5.3.5, transmit intermodulation; for the testing of conformance, the carrier frequencies should be selected to minimize intermodulation products from the transmitters falling in receive channels.

The remaining tests may be performed with or without the duplexer fitted.

NOTE 1: When performing receiver tests with a duplexer fitted, it is important to ensure that the output from the transmitters does not affect the test apparatus. This can be achieved using a combination of attenuators, isolators and filters.

NOTE 2: When duplexers are used, intermodulation products will be generated, not only in the duplexer but also in the antenna system. The intermodulation products generated in the antenna system are not controlled by the specifications, and may degrade during operation (e.g. due to moisture ingress). Therefore, to ensure continued satisfactory operation of a BS, an operator will normally select EARFCNs to minimize intermodulation products falling on receive channels. For testing of complete conformance, an operator may specify the EARFCNs to be used.

B.3 Power supply options

If the BS is supplied with a number of different power supply configurations, it may not be necessary to test RF parameters for each of the power supply options, provided that it can be demonstrated that the range of conditions over which the equipment is tested is at least as great as the range of conditions due to any of the power supply configurations.

This shall apply particularly if a BS contains a DC rail which can be supplied either externally or from an internal mains power supply. In this case, the conditions of extreme power supply for the mains power supply options can be tested by testing only the external DC supply option. The range of DC input voltages for the test should be sufficient to verify the performance with any of the power supplies, over its range of operating conditions within the BS, including variation of mains input voltage, temperature and output current.

B.4 Ancillary RF amplifiers

The requirements of the present document shall be met with the ancillary RF amplifier fitted, if an ancillary amplifier is part of the Base Station. At tests according to clause 5, the ancillary amplifier is connected to the BS by a connecting network (including any cable(s), attenuator(s), etc.) with applicable loss to make sure the appropriate operating conditions of the ancillary amplifier and the BS. The applicable connecting network loss range is declared by the manufacturer. Other characteristics and the temperature dependence of the attenuation of the connecting network are neglected. The actual attenuation value of the connecting network is chosen for each test as one of the applicable extreme values. The lowest value is used unless otherwise stated.

Sufficient tests should be repeated with the ancillary amplifier fitted and, if it is optional, without the ancillary RF amplifier to verify that the BS meets the requirements of the present document in both cases.

When testing, the following tests shall be repeated with the optional ancillary amplifier fitted according to table B.4-1, where x denotes that the test shall apply.

Table B.4-1: Tests applicable to Ancillary RF Amplifiers

	Clause	TX amplifier only	RX amplifier only	TX/RX amplifiers combined (note)
Receiver Tests	5.3.9 (Narrowband blocking)		X	X
	5.3.7		X	X
	5.3.6		X	X
	5.3.8		X	
	5.3.13		X	X
Transmitter Tests	5.3.1	X		X
	5.3.2	X		X
	5.3.3	X		X
	5.3.4	X		X
	5.3.5	X		X
NOTE: Combining can be by duplex filters or any other network. The amplifiers can either be in RX or TX branch or in both. Either one of these amplifiers could be a passive network.				

In test according to clause 5.3.4, the highest applicable attenuation value is applied.

B.5 BS using antenna arrays

B.5.0 General

A BS may be configured with a multiple antenna port connection for some or all of its transceivers or with an antenna array related to one cell (not one array per transceiver). This clause shall apply to a BS which meets at least one of the following conditions:

- the transmitter output signals from one or more transceiver appear at more than one antenna port; or
- there is more than one receiver antenna port for a transceiver or per cell and an input signal is required at more than one port for the correct operation of the receiver thus the outputs from the transmitters as well as the inputs to the receivers are directly connected to several antennas (known as "aircombining"); or

NOTE: Diversity reception does not meet this requirement.

- transmitters and receivers are connected via duplexers to more than one antenna.

In case of diversity or spatial multiplexing, multiple antennas are not considered as an antenna array.

If a BS is used, in normal operation, in conjunction with an antenna system which contains filters or active elements which are necessary to meet the E-UTRA requirements, the conformance tests may be performed on a system comprising the BS together with these elements, supplied separately for the purposes of testing. In this case, it shall be demonstrated that the performance of the configuration under test is representative of the system in normal operation, and the conformance assessment is only applicable when the BS is used with the antenna system.

For conformance testing of such a BS, the following procedure may be used.

B.5.1 Receiver tests

For each test, the test signals applied to the receiver antenna connectors shall be such that the sum of the powers of the signals applied equals the power of the test signal(s) specified in the test.

An example of a suitable test configuration is shown in figure B.5.1-1.

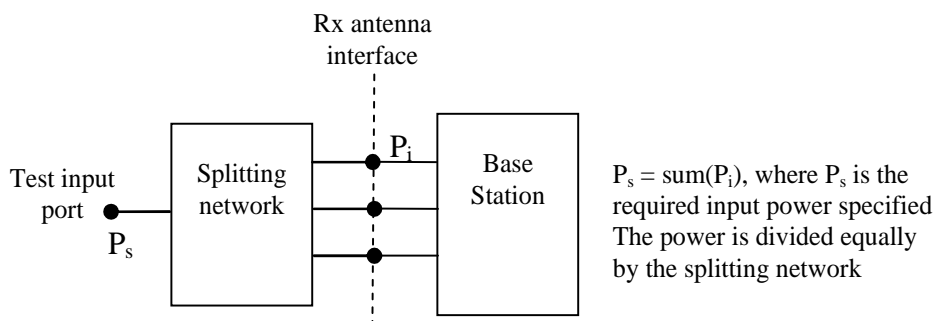

Figure B.5.1-1: Receiver test set-up

For spurious emissions from the receiver antenna connector, the test may be performed separately for each receiver antenna connector.

B.5.2 Transmitter tests

For each test, the test signals applied to the transmitter antenna connectors (P_i) shall be such that the sum of the powers of the signals applied equals the power of the test signal(s) (P_s) specified in the test. This may be assessed by separately measuring the signals emitted by each antenna connector and summing the results, or by combining the signals and performing a single measurement. The characteristics (e.g. amplitude and phase) of the combining network should be such that the power of the combined signal is maximized.

An example of a suitable test configuration is shown in figure B.5.2-1.

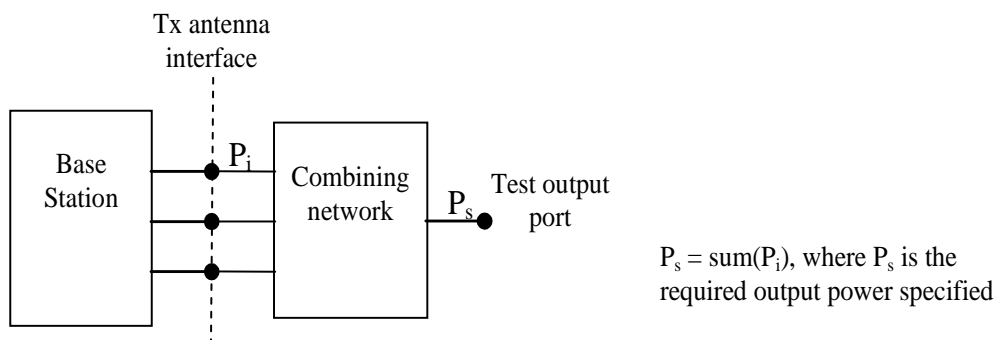

Figure B.5.2-1: Transmitter test set-up

For Intermodulation attenuation, the test may be performed separately for each transmitter antenna connector.

B.6 Transmission with multiple transmitter antenna connectors

Unless otherwise stated, for the tests in clause 5, the requirement shall apply for each transmitter antenna connector in the case of transmission with multiple transmitter antenna connectors.

Transmitter requirements are tested at the antenna connector, with the remaining antenna connector(s) being terminated. If the manufacturer has declared the transmitter paths to be equivalent, it is sufficient to measure the signal at any one of the transmitter antenna connectors.

B.7 BS with integrated Iuant BS modem

Unless otherwise stated, for the tests in the present document, the integrated Iuant BS modem shall be switched off. Spurious emissions according to clauses 5.3.3 and 5.3.6 shall be measured only for frequencies above 20 MHz with the integrated Iuant BS modem switched on.

Annex C (informative): Recommended maximum measurement uncertainty

For the test methods, according to the present document, the measurement uncertainty figures are calculated using expansion factors as described in clause 5.2. The recommended maximum uncertainty values in table C-1 is based on such expansion factors.

Table C-1: Maximum measurement uncertainty

Parameter	Condition	Uncertainty
Operating band unwanted emissions	$f \leq 3,0$ GHz	$\pm 1,5$ dB
	$3,0$ GHz $< f \leq 4,2$ GHz	$\pm 1,8$ dB
	$4,2$ GHz $< f \leq 6,0$ GHz	$\pm 2,2$ dB
Adjacent Channel Leakage power Ratio (ACLR)	ACLR	$\pm 0,8$ dB
	For absolute power requirements:	
	$f \leq 3,0$ GHz	$\pm 2,0$ dB
	$3,0$ GHz $< f \leq 4,2$ GHz	$\pm 2,5$ dB
	$4,2$ GHz $< f \leq 6,0$ GHz	$\pm 3,0$ dB
	CACLR	$\pm 0,8$ dB
For absolute power requirements:		
$f \leq 3,0$ GHz	$\pm 2,0$ dB	
$3,0$ GHz $< f \leq 4,2$ GHz	$\pm 2,5$ dB	
$4,2$ GHz $< f \leq 6,0$ GHz	$\pm 3,0$ dB	
Transmitter spurious emissions	For "Spurious emissions"	
	9 kHz $< f \leq 4$ GHz	$\pm 2,0$ dB
	4 GHz $< f \leq 19$ GHz	$\pm 4,0$ dB
	For co-existence requirements (> -60 dBm)	
	$f \leq 3,0$ GHz	$\pm 2,0$ dB
	$3,0$ GHz $< f \leq 4,2$ GHz	$\pm 2,5$ dB
	$4,2$ GHz $< f \leq 6,0$ GHz	$\pm 3,0$ dB
For co-existence requirements (≤ -60 dBm)		
$f \leq 3,0$ GHz	$\pm 3,0$ dB	
$3,0$ GHz $< f \leq 4,2$ GHz	$\pm 3,5$ dB	
$4,2$ GHz $< f \leq 6,0$ GHz	$\pm 4,0$ dB	
For protection of the BS receiver	$\pm 3,0$ dB	
Base Station maximum output power	$f \leq 3,0$ GHz	$\pm 0,7$ dB
	$3,0$ GHz $< f \leq 4,2$ GHz	$\pm 1,0$ dB
	$4,2$ GHz $< f \leq 6,0$ GHz	$\pm 1,5$ dB
	NB-IoT standalone	$\pm 1,0$ dB
Transmitter intermodulation	For Operating band unwanted emissions	$\pm 2,5$ dB
	For ACLR	$\pm 2,2$ dB
	For "Spurious emissions":	
	$f \leq 2,2$ GHz	$\pm 2,5$ dB
	$2,2$ GHz $< f \leq 4$ GHz	$\pm 2,8$ dB
	$f > 4$ GHz	$\pm 4,5$ dB
For co-existence requirements	$\pm 2,8$ dB	
Interference signal	$\pm 1,0$ dB	
Receiver spurious emissions	30 MHz $\leq f \leq 4$ GHz	$\pm 2,0$ dB
	4 GHz $< f \leq 19$ GHz	$\pm 4,0$ dB
Blocking characteristics	In-band blocking, using modulated interferer:	
	$f \leq 3,0$ GHz	$\pm 1,6$ dB
	$3,0$ GHz $< f \leq 4,2$ GHz	$\pm 2,0$ dB
	$4,2$ GHz $< f \leq 6,0$ GHz	$\pm 2,7$ dB
	Out of band blocking, using CW interferer:	
	$f_{\text{wanted}} \leq 3$ GHz	$\pm 1,3$ dB
	1 MHz $< f_{\text{interferer}} \leq 3$ GHz	$\pm 1,5$ dB
3 GHz $< f_{\text{interferer}} \leq 4,2$ GHz	$\pm 3,2$ dB	
$4,2$ GHz $< f_{\text{interferer}} \leq 12,75$ GHz		

Parameter	Condition	Uncertainty
	$3 \text{ GHz} < f_{\text{wanted}} \leq 4,2 \text{ GHz}$: $1 \text{ MHz} < f_{\text{interferer}} \leq 3 \text{ GHz}$ $3,0 \text{ GHz} < f_{\text{interferer}} \leq 4,2 \text{ GHz}$ $4,2 \text{ GHz} < f_{\text{interferer}} \leq 12,75 \text{ GHz}$ $4,2 \text{ GHz} < f_{\text{wanted}} \leq 6,0 \text{ GHz}$: $1 \text{ MHz} < f_{\text{interferer}} \leq 3 \text{ GHz}$ $3,0 \text{ GHz} < f_{\text{interferer}} \leq 4,2 \text{ GHz}$ $4,2 \text{ GHz} < f_{\text{interferer}} \leq 12,75 \text{ GHz}$	$\pm 1,5 \text{ dB}$ $\pm 1,7 \text{ dB}$ $\pm 3,3 \text{ dB}$ $\pm 1,9 \text{ dB}$ $\pm 2,0 \text{ dB}$ $\pm 3,5 \text{ dB}$
Receiver intermodulation characteristics	$f \leq 3,0 \text{ GHz}$ $3,0 \text{ GHz} < f \leq 4,2 \text{ GHz}$ $4,2 \text{ GHz} < f \leq 6,0 \text{ GHz}$	$\pm 1,8 \text{ dB}$ $\pm 2,4 \text{ dB}$ $\pm 3,3 \text{ dB}$
Adjacent Channel Selectivity (ACS) and narrow-band blocking	$f \leq 3,0 \text{ GHz}$ $3,0 \text{ GHz} < f \leq 4,2 \text{ GHz}$ $4,2 \text{ GHz} < f \leq 6,0 \text{ GHz}$	$\pm 1,4 \text{ dB}$ $\pm 1,8 \text{ dB}$ $\pm 2,5 \text{ dB}$
Reference sensitivity level	$f \leq 3,0 \text{ GHz}$ $3,0 \text{ GHz} < f \leq 4,2 \text{ GHz}$ $4,2 \text{ GHz} < f \leq 6,0 \text{ GHz}$	$\pm 0,7 \text{ dB}$ $\pm 1,0 \text{ dB}$ $\pm 1,5 \text{ dB}$
Base Station output power in band 46		According to ETSI EN 301 893 [8], table 10, clause 5.2
NOTE 1: For RF tests, the uncertainties in table C-1 apply to the test system operating into a nominal 50Ω load and do not include system effects due to mismatch between the EUT and the Test System.		
NOTE 2: Annex G of ETSI TR 100 028-2 [i.5] provides guidance for the calculation of the uncertainty components relating to mismatch.		

Annex D (informative): Bibliography

Directive 2014/30/EU of the European Parliament and of the Council of 26 February 2014 on the harmonisation of the laws of the Member States relating to electromagnetic compatibility (recast). This one is Applicable from 20 April 2016 and repeals the Directive 2004/108/EC.

Directive 2014/35/EU of the European Parliament and of the Council of 26 February 2014 on the harmonisation of the laws of the Member States relating to the making available on the market of electrical equipment designed for use within certain voltage limits (recast) (LV Directive)

CEPT/ERC/REC 74-01 (Siófok 1998, Nice 1999, Sesimbra 2002, Hradec Kralove 2005): "Unwanted Emissions in the Spurious Domain".

Commission Decision 2008/477/EC of 13 June 2008 on the harmonisation of the 2 500-2 690 MHz frequency band for terrestrial systems capable of providing electronic communications services in the Community.

Commission Decision 2010/267/EU of 6 May 2010 on harmonised technical conditions of use in the 790-862 MHz frequency band for terrestrial systems capable of providing electronic communications services in the European Union.

ECC Decision (13)03: "The harmonised use of the frequency band 1452-1492 MHz for Mobile/Fixed Communications Networks Supplemental Downlink (MFCN SDL)".

Commission Decision (EU) 2015/750 of 8 May 2015 on the harmonisation of the 1 452-1 492 MHz frequency band for terrestrial systems capable of providing electronic communications services in the Union.

Regulation (EU) No 1025/2012 of the European Parliament and of the Council of 25 October 2012 on European standardisation amending Council Directives 89/686/EEC and 93/15/EEC and Directives 94/9/EC, 94/25/EC, 95/16/EC, 97/23/EC, 98/34/EC, 2004/22/EC, 2007/23/EC, 2009/23/EC and 2009/105/EC of the European Parliament and of the Council and repealing Council Decision 87/95/EEC and Decision No1673/2006/EC of the European Parliament and of the Council.

ECC Decision (15)01: "Harmonised technical conditions for mobile/fixed communications networks (MFCN) in the band 694-790 MHz including a paired frequency arrangement (Frequency Division Duplex 2x30 MHz) and an optional unpaired frequency arrangement (Supplemental Downlink)", Approved 06 March 2015.

Commission Decision 2005/513/EC of 11 July 2005 on the harmonised use of radio spectrum in the 5 GHz frequency band for the implementation of wireless access systems including radio local area networks (WAS/RLANs).

Commission Decision 2007/90/EC of 12 February 2007 amending Decision 2005/513/EC on the harmonised use of radio spectrum in the 5 GHz frequency band for the implementation of Wireless Access Systems including Radio Local Area Networks (WAS/RLANs).

ECC Decision (16)02: "Harmonised technical conditions and frequency bands for the implementation of Broadband Public Protection and Disaster Relief (BB-PPDR) systems", Approved 17 June 2016.

Annex E (informative): Change history

Version	Information about changes
11.1.2	Editorial corrections after assessments from EC. Clarifications on band 32.
13.1.0	Added requirements for 3GPP Releases 12 and 13 and for BS operating bands from Release 14. Added Base Station for Evolved Universal Terrestrial Radio Access (E-UTRA) with NB-IoT and Base Station for NB-IoT standalone in the scope.

History

Document history				
V4.2.1	March 2010	Publication		
V5.2.1	May 2011	Publication		
V6.2.1	October 2013	Publication		
V7.1.1	July 2015	Publication		
V11.1.1	May 2016	Publication		
V11.1.2	April 2017	Publication		
V13.0.1	December 2017	EN Approval Procedure	AP 20180314:	2017-12-14 to 2018-03-14
V13.1.0	July 2019	Vote	V 20190722:	2019-07-24 to 2019-09-23