

Draft **ETSI EN 301 908-10** V1.1.1 (2001-04)

Candidate Harmonized European Standard (Telecommunications series)

**Electromagnetic compatibility
and Radio spectrum Matters (ERM);
Base Stations (BS) and User Equipment (UE) for
IMT-2000 Third Generation cellular networks;
Part 10: Harmonized Standard for IMT-2000
FDMA/TDMA (DECT)
covering essential requirements of
article 3.2 of the R&TTE Directive**



Reference

DEN/DECT-A0175

KeywordsIMT-2000, 3G, digital, DECT, testing, radio,
regulation, generic**ETSI**

650 Route des Lucioles
F-06921 Sophia Antipolis Cedex - FRANCE

Tel.: +33 4 92 94 42 00 Fax: +33 4 93 65 47 16

Siret N° 348 623 562 00017 - NAF 742 C
Association à but non lucratif enregistrée à la
Sous-Préfecture de Grasse (06) N° 7803/88

Important noticeIndividual copies of the present document can be downloaded from:
<http://www.etsi.org>

The present document may be made available in more than one electronic version or in print. In any case of existing or perceived difference in contents between such versions, the reference version is the Portable Document Format (PDF). In case of dispute, the reference shall be the printing on ETSI printers of the PDF version kept on a specific network drive within ETSI Secretariat.

Users of the present document should be aware that the document may be subject to revision or change of status. Information on the current status of this and other ETSI documents is available at <http://www.etsi.org/tb/status/>

If you find errors in the present document, send your comment to:
editor@etsi.fr

Copyright Notification

No part may be reproduced except as authorized by written permission.
The copyright and the foregoing restriction extend to reproduction in all media.

© European Telecommunications Standards Institute 2001.
All rights reserved.

Contents

Intellectual Property Rights	10
Foreword.....	10
Introduction.....	12
1 Scope.....	14
2 References.....	14
3 Definitions, symbols and abbreviations	15
3.1 Definitions	15
3.2 Symbols	17
3.3 Abbreviations.....	18
4 Technical requirements specifications	18
4.1 Environmental profile.....	18
4.2 Document layout	19
4.2.1 Test suites.....	19
4.2.2 Test groups	19
4.2.3 Test cases	20
4.3 Applicant's declaration	20
4.4 Applicability of essential test suites	20
4.4.1 Introduction	20
4.4.2 Equipment that includes only a DECT RF receiver	21
4.4.3 Equipment that includes a radio transmitter	21
4.4.4 CTAs.....	21
4.4.5 Equipment with a synchronization port.....	21
4.4.6 Equipment incorporating the IPEI (PPs only).....	21
4.4.7 All FP equipment.....	21
4.4.8 Equipment with combined FT and PT functionality	21
4.4.8.1 Introduction.....	21
4.4.8.2 Wireless Relay Station.....	21
4.4.8.3 Direct PP to PP communication	21
4.4.8.4 Distributed Communications.....	22
4.4.9 Provision of 2 Mbit/s services. Equipment that is capable of using 4-level and/or 8-level modulation	22
4.4.10 Dual mode handsets	22
4.5 Conformance requirements.....	22
4.5.1 General	22
4.5.2 Accuracy and stability of RF carriers.....	22
4.5.2.1 Definition of nominal position of RF carriers	22
4.5.2.2 Limits.....	23
4.5.2.3 Conformance.....	23
4.5.3 Accuracy and stability of timing parameters	23
4.5.3.1 Definitions.....	23
4.5.3.1.1 Slot structure.....	23
4.5.3.1.2 Definition of the position of p0.....	24
4.5.3.2 Limits.....	24
4.5.3.2.1 Reference timer accuracy and stability.....	24
4.5.3.2.2 RFP transmission jitter	25
4.5.3.2.3 PP reference timer synchronization.....	25
4.5.3.3 Conformance.....	25
4.5.4 Transmission burst.....	25
4.5.4.1 Definitions.....	25
4.5.4.1.1 Introduction	25
4.5.4.1.2 Physical packets	26
4.5.4.1.3 Transmitted power	26
4.5.4.1.4 Normal Transmitted Power (NTP)	26
4.5.4.1.5 Transmitter attack time.....	26

4.5.4.1.6	Transmitter release time	26
4.5.4.1.7	Minimum power	26
4.5.4.1.8	Maximum power	26
4.5.4.1.9	Maintenance of transmission after packet end	26
4.5.4.1.10	Transmitter idle power output	27
4.5.4.2	Limits	27
4.5.4.2.1	Transmitter attack time	27
4.5.4.2.2	Transmitter release time	27
4.5.4.2.3	Minimum power	27
4.5.4.2.4	Maximum power	27
4.5.4.2.5	Maintenance of transmission after packet end	27
4.5.4.2.6	Transmitter idle power output	27
4.5.4.3	Conformance	27
4.5.5	Transmitted power	27
4.5.5.1	Definitions	27
4.5.5.1.1	PP and RFP with an integral antenna	27
4.5.5.1.2	PP and RFP with external connections for all antennas	27
4.5.5.1.3	PP and RFP with both integral and external antennas	28
4.5.5.2	Limits	28
4.5.5.3	Conformance	28
4.5.6	RF carrier modulation	28
4.5.6.1	Definition	28
4.5.6.2	Limits	28
4.5.6.3	Conformance	29
4.5.7	Unwanted RF power radiation	29
4.5.7.1	General	29
4.5.7.2	Emissions due to modulation	29
4.5.7.2.1	Definition	29
4.5.7.2.2	Limits	29
4.5.7.2.3	Conformance	29
4.5.7.3	Emissions due to transmitter transients	29
4.5.7.3.1	Definition	29
4.5.7.3.2	Limits	30
4.5.7.3.3	Conformance	30
4.5.7.4	Emissions due to intermodulation	30
4.5.7.4.1	Definition	30
4.5.7.4.2	Limits	30
4.5.7.4.3	Conformance	30
4.5.7.5	Spurious emissions when allocated a transmit channel	30
4.5.7.5.1	Definition	30
4.5.7.5.2	Limits	30
4.5.7.5.3	Conformance	31
4.5.8	Radio receiver testing	31
4.5.8.1	Radio receiver sensitivity	31
4.5.8.1.1	Definition	31
4.5.8.1.2	Limits	31
4.5.8.1.3	Conformance	31
4.5.8.2	Radio receiver reference BER and FER	32
4.5.8.2.1	Definition	32
4.5.8.2.2	Limits	32
4.5.8.2.3	Conformance	32
4.5.8.3	Radio receiver interference performance	32
4.5.8.3.1	Definition	32
4.5.8.3.2	Limits	32
4.5.8.3.3	Conformance	32
4.5.8.4	Radio receiver blocking case 1: owing to signals occurring at the same time but on other frequencies	32
4.5.8.4.1	Definition	32
4.5.8.4.2	Limits	33
4.5.8.4.3	Conformance	33
4.5.8.5	Radio receiver blocking case 2: owing to signals occurring at a different time	33
4.5.8.5.1	Definition	33

4.5.8.5.2	Limits	33
4.5.8.5.3	Conformance.....	33
4.5.8.6	Receiver intermodulation performance.....	33
4.5.8.6.1	Definition.....	33
4.5.8.6.2	Limits	34
4.5.8.6.3	Conformance.....	34
4.5.8.7	Spurious emissions when the PP has no allocated transmit channel.....	34
4.5.8.7.1	Definition.....	34
4.5.8.7.2	Limits	34
4.5.8.7.3	Conformance.....	34
4.5.9	Intersystem synchronization (FP only).....	34
4.5.9.1	Description	34
4.5.9.2	Wired synchronization ports	35
4.5.9.2.1	FP as a master	35
4.5.9.2.2	FP as a slave.....	35
4.5.9.3	GPS synchronization	36
4.5.9.3.1	FP with integrated Global Positioning System (GPS) synchronization	36
	Conformance tests as defined in clause 5.3.9.3.1 shall be carried out.	36
4.5.9.3.2	External GPS synchronization device	36
4.5.9.3.2.2	Conformance.....	37
	Conformance tests as defined in clause 5.3.9.3.2 shall be carried out.	37
4.5.10	Equipment identity testing.....	37
4.5.10.1	PP	37
4.5.10.2	FP	37
4.5.11	Efficient use of the radio spectrum	37
4.5.11.1	Channel selection.....	37
4.5.11.2	Channel confirmation	37
4.5.11.2.1	For the PT.....	37
4.5.11.2.2	For the FT	37
4.5.11.3	Channel release	38
4.5.11.4	General.....	38
4.5.12	WRS testing.....	38
4.5.12.1	General requirements.....	38
4.5.12.2	Testing as a PP	38
4.5.12.3	Testing as an RFP	39
4.5.12.4	Additional requirements.....	39
4.5.12.5	Conformance.....	43
4.5.13	Requirements for PPs with direct PP to PP communication mode.....	43
4.5.13.1	General requirements.....	43
4.5.13.2	Setting the EUT in direct communications mode	43
4.5.13.3	When the EUT has not initiated a call	43
4.5.13.4	When the EUT initiates a call.....	44
4.5.13.5	Conformance.....	44
4.5.14	Distributed Communications	44
4.5.14.1	General requirements.....	44
4.5.14.2	Testing as a PP	44
4.5.14.3	Testing as an RFP	45
4.5.14.4	Conformance.....	45
4.5.15	Higher level modulation options.....	45
4.5.15.1	Requirements.....	45
4.5.15.2	Conformance.....	46
5	Testing for compliance with technical requirements	46
5.1	General test requirements	46
5.1.1	Test philosophy.....	46
5.1.2	Standard position	47
5.1.3	Test antenna of the LT	47
5.1.4	Substitution antenna.....	48
5.1.5	Test fixture	48
5.1.5.1	Description	48
5.1.5.2	Calibration of the test fixture for the measurement of transmitter characteristics	48
5.1.5.3	Calibration of the test fixture for the measurement of receiver characteristics.....	49

5.1.5.4	Mode of use.....	49
5.1.6	Equipment with a temporary or internal permanent antenna connector	50
5.1.6.1	General.....	50
5.1.6.2	Equipment with a temporary antenna connector.....	50
5.1.7	Lower Tester (LT).....	51
5.1.7.1	Description.....	51
5.1.7.2	Connections between the EUT and the LT.....	51
5.1.7.3	Functions and abilities	51
5.1.7.4	Signal generation uncertainty.....	52
5.1.7.5	Modulated DECT-like carrier.....	52
5.1.7.6	CW interferers.....	52
5.1.7.7	DECT RF signal.....	52
5.1.7.8	Test modulation signals	52
5.1.8	Upper Tester (UT).....	52
5.1.8.1	Description of the UT.....	52
5.1.8.2	The test standby mode	53
5.1.8.3	Test messages.....	53
5.1.8.4	Dummy setting when EUT is a RFP and it is in test stand-by mode	53
5.1.9	Description of the lower tester FT and PT.....	53
5.1.10	General test methods.....	54
5.1.10.1	General.....	54
5.1.10.2	Sampling the RF signal.....	54
5.1.10.2.1	Introduction	54
5.1.10.2.2	Sampling method	54
5.1.10.3	Determining the reference position.....	54
5.1.10.3.1	Case 1: EUTs that cannot transmit	54
5.1.10.3.2	Case 2: EUTs that can transmit.....	54
5.1.10.4	Bit error rate (BER) and Frame Error Ratio (FER) measurements.....	54
5.1.11	Test setup	55
5.1.11.1	General.....	55
5.1.11.2	Test setup 1	55
5.1.11.3	Test setup 2	55
5.1.11.4	Test setup 3	56
5.1.11.5	Test setup 4	56
5.1.11.6	Test setup 5	57
5.1.12	Test arrangements for intermodulation measurements.....	57
5.1.12.1	PT to PT arrangement.....	57
5.1.12.2	FT to FT arrangement.....	58
5.1.12.3	FT to PT arrangement.....	58
5.1.13	Test conditions, power supply and ambient temperatures	59
5.1.13.1	General.....	59
5.1.13.2	Nominal test conditions	59
5.1.13.3	Extreme test conditions.....	60
5.1.13.4	Test power source - general requirements.....	61
5.1.13.5	Nominal test power source.....	61
5.1.13.5.1	Mains voltage.....	61
5.1.13.5.2	Regulated lead acid battery power sources	61
5.1.13.5.3	Nickel cadmium battery.....	61
5.1.13.5.4	Other power sources.....	61
5.1.13.6	Extreme test power source	61
5.1.13.6.1	Mains voltage.....	61
5.1.13.6.2	Regulated lead acid battery power sources	61
5.1.13.6.3	Nickel cadmium battery.....	61
5.1.13.6.4	Other power sources.....	62
5.1.13.7	Testing of host connected equipment and plug-in cards	62
5.1.13.7.1	Permitted approaches	62
5.1.13.7.2	Alternative A: composite equipment.....	62
5.1.13.7.3	Alternative B: use of a test jig and three hosts	62
5.2	Interpretation of the measurement results.....	63
5.3	Essential radio test suites	63
5.3.1	General.....	63
5.3.2	Accuracy and stability of RF carriers.....	64

5.3.2.1	Test environment.....	64
5.3.2.2	Method of measurement.....	64
5.3.2.3	Verdict criteria when the EUT is a RFP.....	64
5.3.2.3a	Verdict criteria when the EUT is a PP.....	65
5.3.3	Accuracy and stability of timing parameters.....	65
5.3.3.1	Measurement of packet timing jitter.....	65
5.3.3.1.1	Test environment.....	65
5.3.3.1.2	Method of measurement.....	65
5.3.3.1.3	Verdict criteria.....	66
5.3.3.2	Measurement of the reference timing accuracy of a RFP.....	66
5.3.3.2.1	Test environment.....	66
5.3.3.2.2	Method of measurement.....	66
5.3.3.2.3	Verdict criteria.....	66
5.3.3.3	Measurement of packet transmission accuracy of a PP.....	66
5.3.3.3.1	Test environment.....	66
5.3.3.3.2	Method of measurement.....	67
5.3.3.3.3	Verdict criteria.....	67
5.3.4	Transmission burst.....	67
5.3.4.1	Test environment.....	67
5.3.4.2	Method of measurement.....	68
5.3.4.3	Verdict criteria.....	68
5.3.5	Transmitted power.....	68
5.3.5.1	PP and RFP with an integral antenna.....	68
5.3.5.1.1	Test environment.....	68
5.3.5.1.2	Method of measurement.....	69
5.3.5.1.3	Verdict criteria for all EUTs.....	69
5.3.5.2	PP and RFP with external antenna connection(s).....	70
5.3.5.2.1	Test environment.....	70
5.3.5.2.2	Method of measurement.....	70
5.3.5.2.3	Verdict criteria for all EUTs.....	70
5.3.6	RF carrier modulation.....	70
5.3.6.1	Test environment.....	70
5.3.6.2	Method of measurement, Parts 1 and 2.....	71
5.3.6.2.1	Introduction.....	71
5.3.6.2.2	Part 1.....	71
5.3.6.2.3	Part 2.....	71
5.3.6.3	Method of measurement, Parts 3 and 4.....	72
5.3.6.3.1	General.....	72
5.3.6.3.2	Part 3.....	72
5.3.6.3.3	Part 4.....	72
5.3.6.4	Verdict criteria for Part 1.....	72
5.3.6.5	Verdict criteria for Part 2.....	73
5.3.6.6	Verdict criteria for Part 3.....	73
5.3.6.7	Verdict criteria for Part 4.....	73
5.3.7	Unwanted RF power radiation.....	74
5.3.7.1	General test conditions.....	74
5.3.7.2	Emissions due to modulation.....	74
5.3.7.2.1	Test environment.....	74
5.3.7.2.2	Method of measurement.....	74
5.3.7.2.3	Verdict criteria.....	75
5.3.7.3	Emissions due to transmitter transients.....	75
5.3.7.3.1	Test environment.....	75
5.3.7.3.2	Method of measurement.....	76
5.3.7.3.3	Verdict criteria.....	76
5.3.7.4	Emissions due to intermodulation.....	77
5.3.7.4.1	Test environment.....	77
5.3.7.4.2	Method of measurement.....	77
5.3.7.4.3	Verdict criteria.....	78
5.3.7.5	Spurious emissions when allocated a transmit channel.....	78
5.3.7.5.1	Radiated emissions.....	78
5.3.7.5.1.1	Test environment.....	78
5.3.7.5.1.2	Method of measurement.....	78

5.3.7.5.2	Conducted spurious emissions	79
5.3.8	Radio receiver testing	80
5.3.8.1	Radio receiver sensitivity	80
5.3.8.1.1	Test environment	80
5.3.8.1.2	Method of measurement	80
5.3.8.1.3	Verdict criteria	81
5.3.8.2	Radio receiver reference BER and FER	81
5.3.8.2.1	Test environment	81
5.3.8.2.2	Method of measurement	81
5.3.8.2.3	Verdict criteria	81
5.3.8.3	Radio receiver interference performance	82
5.3.8.3.1	Test environment	82
5.3.8.3.2	Method of measurement	82
5.3.8.3.3	Verdict criteria	82
5.3.8.4	Radio receiver blocking case 1: owing to signals occurring at the same time but on other frequencies	82
5.3.8.4.1	Test environment	82
5.3.8.4.2	Method of measurement	83
5.3.8.4.3	Verdict criteria	84
5.3.8.5	Radio receiver blocking case 2: owing to signals occurring at a different time	84
5.3.8.5.1	Test environment	84
5.3.8.5.2	Method of measurement	84
5.3.8.5.3	Verdict criteria	85
5.3.8.6	Receiver intermodulation performance	85
5.3.8.6.1	Test environment	85
5.3.8.6.2	Method of measurement	85
5.3.8.6.3	Verdict criteria	85
5.3.8.7	Spurious emissions when the PP has no allocated transmit channel	86
5.3.8.7.1	Test environment	86
5.3.8.7.2	Method of measurement	86
5.3.8.7.3	Verdict criteria (outside the DECT band)	86
5.3.8.7.4	Verdict criteria (inside the DECT band)	86
5.3.9	Intersystem synchronization (FP only)	87
5.3.9.1	Test environment	87
5.3.9.2	Wired synchronization ports	87
5.3.9.2.1	FP as a master	87
5.3.9.2.1.2	Verdict criteria	87
5.3.9.2.2	FP as a slave	88
5.3.9.3	GPS synchronization	89
5.3.9.3.1	FP with integrated Global Positioning System (GPS) synchronization	89
5.3.9.3.2	External GPS synchronization device	89
5.3.10	Equipment identity testing	90
5.3.11	Efficient use of the radio spectrum	90
5.3.12	WRS testing	90
5.3.12.1	General	90
5.3.12.2	Testing as a PP	90
5.3.12.3	Testing as an RFP	90
5.3.12.4	Additional requirements	91
5.3.13	Requirements for PPs with direct PP to PP communication mode	91
5.3.13.1	General	91
5.3.13.2	Setting the EUT in direct communications mode	91
5.3.13.3	When the EUT has not initiated a call	91
5.3.13.4	When the EUT initiates a call	92
5.3.13.5	Applicants declarations	92
5.3.14	Distributed Communications	92
5.3.14.1	General	92
5.3.14.2	Testing as a PP	93
5.3.14.3	Testing as an RFP	93
5.3.14.4	Applicants declaration	93
5.3.15	Higher level modulation options	93
5.3.15.1	General	93
5.3.15.2	Activation of higher level modulations when EUT is in test stand-by mode	94

5.3.15.3	Applicants declaration	94
Annex A (normative):	The EN Requirements Table (EN-RT).....	95
Annex B (normative):	Procedures for test fixture calibration	97
B.1	Calibration of test fixture for receiver measurements.....	97
B.1.1	Procedure.....	97
B.1.2	Method of measurement	97
Annex C (normative):	Test Support Profile (TSP)	99
C.1	Introduction.....	99
C.2	Standardized symbols for the status column	99
C.3	Capabilities of PP (EUT) under test	100
C.3.1	Services	100
C.3.2	Messages.....	100
C.3.3	Message parameters	101
C.3.4	Procedure support.....	103
C.3.5	CSF multiplexing functions	104
C.3.6	Timer and counter support.....	104
C.4	Capabilities of FP (EUT) under test	105
C.4.1	Services	105
C.4.2	Messages.....	105
C.4.3	Message parameters	106
C.4.4	Procedure support.....	108
C.4.5	CSF multiplexing functions	109
C.4.6	Timer and counter support.....	109
Annex D (normative):	Measurement of BER and FER.....	110
Annex E (informative):	Procedures for the measurement of synchronization loss at the EUT by the LT.....	111
E.1	Description.....	111
E.2	Method.....	111
Annex F (informative):	DECT carrier numbers and carrier positions in the range 1 880 MHz to 2025 MHz.....	112
F.1	Introduction.....	112
F.2	1 880 MHz to 1 940 MHz RF band 00001.....	113
F.3	1 880 MHz to 1 925 and 2 010 to 2 025 MHz RF band 00010	114
F.4	1 880 MHz 1 900 MHz, 1 915 MHz to 1 940 MHz and 2 010 MHz to 2 025 MHz RF band 00011 ..	115
F.5	1 880 MHz to 1 900, 1 935 MHz to 1 960 and 2 010 MHz to 2 025 MHz RF band 00100.....	116
F.6	1 880 MHz to 1 900 MHz, 1 955 MHz to 1 980 MHz and 2 010 MHz to 2 025 MHz RF band 00101	117
Annex G (informative):	The EN title in the official languages.....	118
Annex H (informative):	Bibliography.....	119
History	120

Intellectual Property Rights

IPRs essential or potentially essential to the present document may have been declared to ETSI. The information pertaining to these essential IPRs, if any, is publicly available for **ETSI members and non-members**, and can be found in ETSI SR 000 314: *"Intellectual Property Rights (IPRs); Essential, or potentially Essential, IPRs notified to ETSI in respect of ETSI standards"*, which is available from the ETSI Secretariat. Latest updates are available on the ETSI Web server (<http://www.etsi.org/ipr>).

Pursuant to the ETSI IPR Policy, no investigation, including IPR searches, has been carried out by ETSI. No guarantee can be given as to the existence of other IPRs not referenced in ETSI SR 000 314 (or the updates on the ETSI Web server) which are, or may be, or may become, essential to the present document.

Foreword

This Candidate Harmonized European Standard (Telecommunications series) has been produced by ETSI Project Digital Enhanced Cordless Telecommunications (DECT), and is now submitted for the Public Enquiry phase of the ETSI standards Two-step Approval Procedure.

The present document is part 10 of a multi-part deliverable covering the Base Stations (BS) and User Equipment (UE) for IMT-2000 Third-Generation cellular networks, as identified below:

- Part 1: "Harmonized standard for IMT-2000, Introduction and common requirements, covering essential requirements of article 3.2 of the R&TTE Directive";
- Part 2: "Harmonized standard for IMT-2000, CDMA Direct Spread (UTRA FDD) (UE) covering essential requirements of article 3.2 of the R&TTE Directive";
- Part 3: "Harmonized standard for IMT-2000, CDMA Direct Spread (UTRA FDD) (BS) covering essential requirements of article 3.2 of the R&TTE Directive";
- Part 4: "Harmonized standard for IMT-2000, CDMA Multi-Carrier (cdma2000) (UE) covering essential requirements of article 3.2 of the R&TTE Directive";
- Part 5: "Harmonized standard for IMT-2000, CDMA Multi-Carrier (cdma2000) (BS) covering essential requirements of article 3.2 of the R&TTE Directive";
- Part 6: "Harmonized standard for IMT-2000, CDMA TDD (UTRA TDD) (UE) covering essential requirements of article 3.2 of the R&TTE Directive";
- Part 7: "Harmonized standard for IMT-2000, CDMA TDD (UTRA TDD) (BS) covering essential requirements of article 3.2 of the R&TTE Directive";
- Part 8: "Harmonized standard for IMT-2000, TDMA Single-Carrier (UWC 136) (UE) covering essential requirements of article 3.2 of the R&TTE Directive";
- Part 9: "Harmonized standard for IMT-2000, TDMA Single-Carrier (UWC 136) (BS) covering essential requirements of article 3.2 of the R&TTE Directive";
- Part 10: "Harmonized standard for IMT-2000 FDMA/TDMA (DECT) covering essential requirements of article 3.2 of the R&TTE Directive".**

The present document has been produced by ETSI in response to a mandate from the European Commission issued under Council Directive 98/34/EC laying down a procedure for the provision of information in the field of technical standards and regulations.

The present document is intended to become a Harmonized Standard, the reference of which will be published in the Official Journal of the European Communities referencing the Directive 1999/5/EC of the European Parliament and of the Council of 9 March 1999 on radio equipment and telecommunications terminal equipment and the mutual recognition of their conformity ("the R&TTE Directive") [1].

Proposed national transposition dates

Date of latest announcement of this EN (doa):	3 months after ETSI publication
Date of latest publication of new National Standard or endorsement of this EN (dop/e):	6 months after doa
Date of withdrawal of any conflicting National Standard (dow):	18 months after doa

Introduction

The present document is part of a set of standards designed to fit in a modular structure to cover all radio and telecommunications terminal equipment under the R&TTE Directive [1]. Each standard is a module in the structure. The modular structure is shown in figure 1.

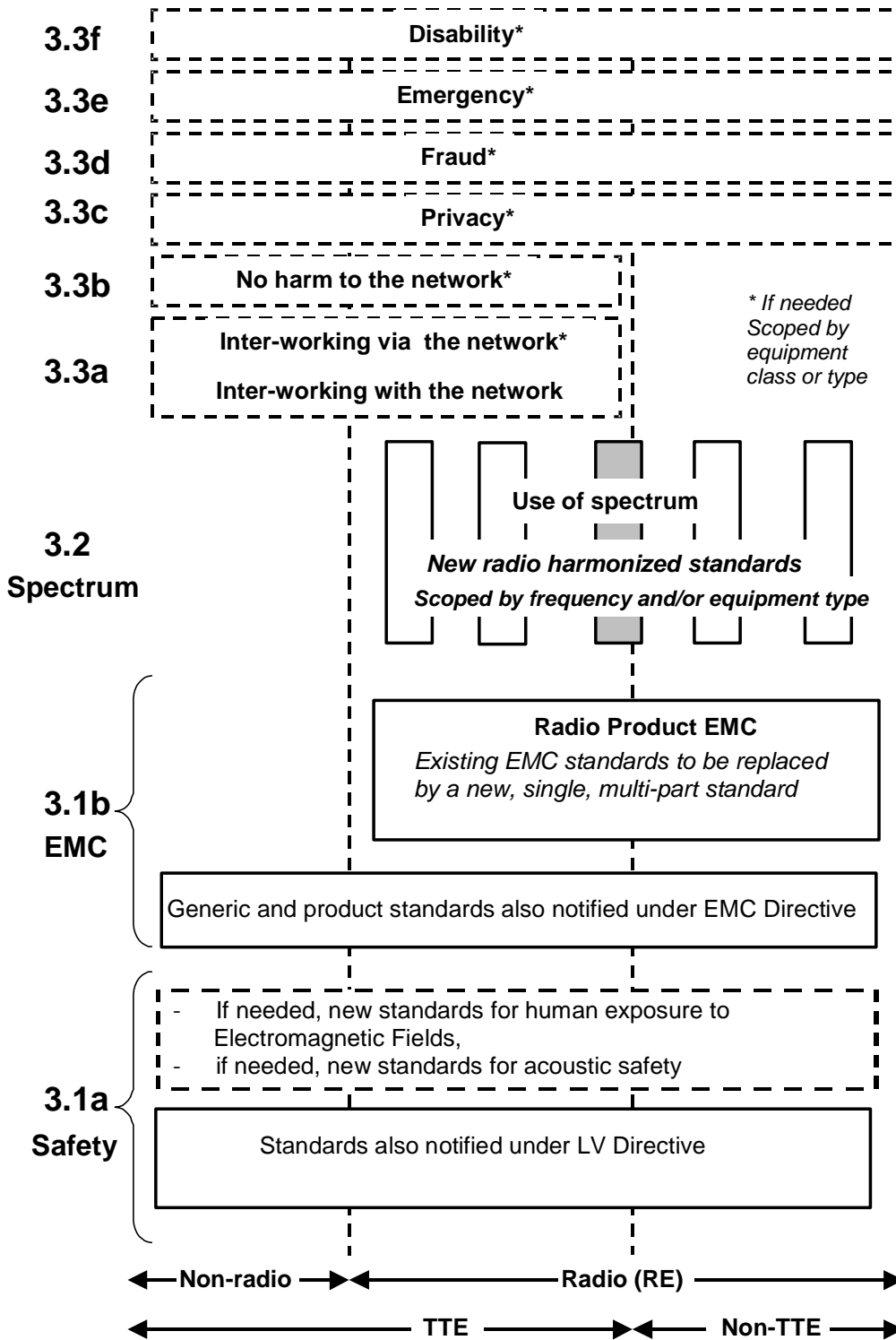

Figure 1: Modular structure for the various standards used under the R&TTE Directive [1]

The left hand edge of the figure 1 shows the different clauses of article 3 of the R&TTE Directive [1].

For article 3.3 various horizontal boxes are shown. Dotted lines indicate that at the time of publication of this standard essential requirements in these areas have to be adopted by the Commission. If such essential requirements are adopted, and as far and as long as they are applicable, they will justify individual standards whose scope is likely to be specified by function or interface type.

The vertical boxes show the standards under article 3.2 for the use of the radio spectrum by radio equipment. The scopes of these standards are specified either by frequency (normally in the case where frequency bands are harmonized) or by radio equipment type.

For article 3.1b the diagram shows EN 301 489 [19], the multi-part product EMC standard for radio, and the existing collection of generic and product standards currently used under the EMC Directive [2].

For article 3.1a the diagram shows the existing safety standards currently used under the LV Directive [3] and new standards covering human exposure to electromagnetic fields. New standards covering acoustic safety may also be required.

The bottom of the figure shows the relationship of the standards to radio equipment and telecommunications terminal equipment. A particular equipment may be radio equipment, telecommunications terminal equipment or both. A radio spectrum standard will apply if it is radio equipment. An article 3.3 standard will apply as well only if the relevant essential requirement under the R&TTE Directive [1] is adopted by the Commission and if the equipment in question is covered by the scope of the corresponding standard. Thus, depending on the nature of the equipment, the essential requirements under the R&TTE Directive [1] may be covered in a set of standards.

The modularity principle has been taken because:

- it minimizes the number of standards needed. Because equipment may, in fact, have multiple interfaces and functions it is not practicable to produce a single standard for each possible combination of functions that may occur in an equipment;
- it provides scope for standards to be added:
 - under article 3.2 when new frequency bands are agreed; or
 - under article 3.3 should the Commission take the necessary decisions;without requiring alteration of standards that are already published,
- it clarifies, simplifies and promotes the usage of Harmonized Standards as the relevant means of conformity assessment.

The product specifications upon which this present multi-part deliverable is based differ in presentation, and this is reflected in the present document.

1 Scope

The present document applies to terminal equipment for IMT-FT. IMT-FT is the Digital Enhanced Cordless Telecommunications (DECT) system being a member of the ITU IMT-2000 family [15]. DECT terminal equipment consists of the following elements:

- a) Fixed Part (FP);
- b) Portable Part (PP);
- c) Cordless Terminal Adapter (CTA);
- d) Wireless Relay Station (WRS) (FP and PP combined).

The IMT-FT (DECT) service frequency bands for transmitting and receiving for all elements are the parts of the European UMTS spectrum applicable for TDD operation, 1 900 MHz to 1 980 MHz and 2 010 MHz to 2 025 MHz. (see ERC/DEC/(99)25 [16] and ERC/DEC/(00)01 [17]).

NOTE 1: IMT-FT equipment may have a second mode for providing operation also in the DECT band 1 880 to 1 900 MHz. Application of DECT in the band 1 880 - 1 900 MHz is covered by EN 301 406 [18] "Harmonized EN for Digital Enhanced Cordless Telecommunications (DECT) covering essential requirements under article 3.2 of the R&TTE Directive" [1].

The present document is intended to cover the provisions of Directive 1999/5/EC (R&TTE Directive) [1] article 3.2, which states that "..... radio equipment shall be so constructed that it effectively uses the spectrum allocated to terrestrial/space radio communications and orbital resources so as to avoid harmful interference".

In addition to the present document, other ENs that specify technical requirements in respect of essential requirements under other parts of article 3 of the R&TTE Directive [1] will apply to equipment within the scope of the present document.

NOTE 2: A list of such ENs is included on the web site: <http://www.newapproach.org/>.

2 References

The following documents contain provisions which, through reference in this text, constitute provisions of the present document.

- References are either specific (identified by date of publication and/or edition number or version number) or non-specific.
- For a specific reference, subsequent revisions do not apply.
- For a non-specific reference, the latest version applies.

- [1] Directive 1999/5/EC of the European Parliament and of the Council of 9 March 1999 on radio equipment and telecommunications terminal equipment and the mutual recognition of their conformity (R&TTE Directive).
- [2] Council Directive 89/336/EEC of 3 May 1989 on the approximation of the laws of the Member States relating to electromagnetic compatibility (EMC Directive).
- [3] Council Directive 73/23/EEC of 19 February 1973 on the harmonization of the laws of Member States relating to electrical equipment designed for use within certain voltage limits (LV Directive).
- [4] ETSI EN 300 175-2 (V1.5.1): "Digital Enhanced Cordless Telecommunications (DECT); Common Interface (CI); Part 2: Physical layer (PHL)".
- [5] ETSI EN 300 175-3 (V1.5.1): "Digital Enhanced Cordless Telecommunications (DECT); Common Interface (CI); Part 3: Medium Access Control (MAC) layer".

- [6] ETSI EN 300 175-5 (V1.5.1): "Digital Enhanced Cordless Telecommunications (DECT); Common Interface (CI); Part 5: Network (NWK) layer".
- [7] ETSI EN 300 175-6 (V1.5.1): "Digital Enhanced Cordless Telecommunications (DECT); Common Interface (CI); Part 6: Identities and addressing".
- [8] ISO/IEC 9646-1 (1994): "Information technology - Open Systems Interconnection - Conformance testing methodology and framework - Part 1:General concepts".
- [9] ITU-T Recommendation V.11 (1996): "Electrical characteristics for balanced double-current interchange circuits operating at data signaling rates up to 10 Mbit/s".
- [10] ETSI EN 300 700 (1.2.1): "Digital Enhanced Cordless Telecommunications (DECT); Wireless Relay Station (WRS)".
- [11] ITU-T Recommendation O.153 (1988): "Basic parameters for the measurement of error performance at bit rates below the primary rate".
- [12] EN 55022 (1998): "Information technology equipment - Radio disturbance characteristics - Limits and methods of measurement".
- [13] ETSI ETR 028 (2nd Edition, March 1994): "Radio Equipment and Systems (RES); Uncertainties in the measurement of mobile radio equipment characteristics".
- [14] ITU-T Recommendation G.726: "40, 32, 24, 16 kbit/s adaptive differential pulse code modulation (ADPCM)".
- [15] ITU-R Recommendation M.1457: "Detailed specifications of the radio interface of IMT-2000".
- [16] ERC/DEC/(99)25: "ERC Decision of 29 November 1999 on the harmonized utilization of spectrum for terrestrial Universal Mobile Telecommunications System (UMTS) operating within the bands 1900 – 1980 MHz, 2010 - 2025 MHz and 2110 - 2170 MHz".
- [17] ERC/DEC/(00)01: "ERC Decision of 28 March 2000 extending ERC/DEC/(97)07 on the frequency bands for introduction of terrestrial Universal Mobile Telecommunications System (UMTS)".
- [18] EN 301 406 (V1.4.1): "Digital Enhanced Cordless Telecommunications (DECT); Harmonized EN for Digital Enhanced Cordless Telecommunications (DECT) covering essential requirements under article 3.2 of the R&TTE directive; Generic radio".
- [19] ETSI EN 301 489: "Electromagnetic compatibility and Radio spectrum Matters (ERM); ElectroMagnetic Compatibility (EMC) standard for radio equipment and services".

3 Definitions, symbols and abbreviations

3.1 Definitions

For the purposes of the present document, the terms and definitions given in the R&TTE Directive [1], and the following apply.

antenna diversity: antenna diversity implies that the Radio Fixed Part (RFP) for each bearer independently can select different antenna properties such as gain, polarization, coverage patterns, and other features that may effect the practical coverage

A typical example is space diversity, provided by two vertically polarized antennas separated by 10 - 20 cm.

bearer handover: internal handover process provided by the Medium Access Control (MAC) layer, whereby one MAC connection can modify its underlying bearers while maintaining the service provided to the Data Link Control (DLC) layer

NOTE 1: Bearer handover is slot based.

cell: domain served by a single antenna system (including a leaky feeder) of one FP.

NOTE 2: A cell may include more than one source of radiated Radio Frequency energy (i.e. more than one Radio End Point).

Central Control Fixed Part (CCFP): physical grouping that contains the central elements of a FP. A FP shall contain a maximum of one CCFP.

NOTE 3: A CCFP controls one or more RFPs.

conducted measurements: measurements which are made using a direct connection to the equipment under test.

Cordless Terminal Adapter (CTA): physical grouping that contains a DECT portable termination and a line interface.

DECT Distributed communications: DECT Distributed communication is regarded as a communication capability of a DECT Local Network that allows a number of DECT terminals (a FP and number of PPs) to co-exists and directly communicate one with another.

DECT-like carrier: RF DECT carrier modulated by a psuedo random sequence used for interference testing.

Double Slot (SLOT): one 12th of a Time Division Multiple Access (TDMA) frame which is used to support one high capacity physical channel

duplex bearer: use of two simplex bearers operating in opposite directions on two physical channels. These pairs of channels always use the same RF carrier and always use evenly spaced slots (i.e. separated by 0,5 TDMA frame)

environmental profile: Range of environmental conditions under which equipment within the scope of the present document is required to comply with the provisions of the present document

Equipment Under Test (EUT): equipment submitted to the test laboratory for type examination.

Fixed Part (DECT Fixed Part) (FP): physical grouping that contains all of the elements in the DECT network between the local network and the DECT air interface

NOTE 4: A DECT FP contains the logical elements of at least one Fixed radio Termination (FT), plus additional implementation specific elements.

Fixed radio Termination (FT): logical group of functions that contains all of the DECT processes and procedures on the fixed side of the DECT air interface

NOTE 5: A FT only includes elements that are defined in the DECT CI standard. This includes radio transmission elements (layer 1) together with a selection of layer 2 and layer 3 elements.

full slot (slot): one 24th of a TDMA frame which is used to support one physical channel

half slot: one 48th of a TDMA frame which is used to support one physical channel

handover: process of switching a call in progress from one physical channel to another physical channel. These processes can be internal or external. Internal handover refers to handover between RFP's that belong to the same system and are synchronized to each other.

NOTE 6: There are two physical forms of handover: intra-cell handover and inter-cell handover. Intra-cell handover is always internal. Inter-cell handover can be internal or external.

host equipment: is any equipment which has a complete user functionality when not connected to the DECT radio equipment, and to which the DECT radio equipment provides additional functionality, and to which connection is necessary for the DECT radio equipment to offer functionality.

Hybrid Part (HyP): HyP is a DECT terminal that provides FT, as well as, PT capabilities being capable of communicating directly with FT or PT

IMT-2000: International Mobile Telecommunications, Third Generation Mobile Systems.

IMT-FT: International Mobile Telecommunications, FDMA/TDMA
This is the DECT family member of IMT-2000.

inter-cell handover: switching of a call in progress from one cell to another cell.

NOTE 7: This only defines the form of handover, it does not define a specific process.

intra-cell handover: switching of a call in progress from one physical channel of one cell to another physical channel of the same cell.

NOTE 8: This only defines the form of handover, it does not define a specific process.

Lower Tester (LT): logical grouping that contains the test equipment, a functionally equivalent DECT PT, a functionally equivalent DECT FT and a test controller.

multiframe: repeating sequence of 16 successive TDMA frames, that allows low rate or sporadic information to be multiplexed (e.g. basic system information or paging).

physical channel (channel): simplex channel that is created by transmitting in one particular slot on one particular RF channel in successive TDMA frames (see also simplex bearer).

NOTE 9: One physical channel provides a simplex service. Two physical channels are required to provide a duplex service.

Portable Handset (PHS): single physical grouping that contains all of the portable elements that are needed to provide a teleservice to the user.

NOTE 10: PHS is a subset of all possible PPs. This subset includes all physical groupings that combine one PT plus at least one portable application in a single physical box.

Portable Part (PP): physical grouping that contains all elements between the user and the DECT air interface. PP is a generic term that may describe one or several physical pieces.

NOTE 11: A PP is logically divided into one PT plus one or more portable applications.

Portable radio Termination (PT): logical group of functions that contains all of the DECT processes and procedures on the portable side of the DECT air interface.

NOTE 12: A PT only includes elements that are defined in the DECT CI standard. This includes radio transmission elements together with a selection of layer 2 and layer 3 elements.

radiated measurements: measurements which involve the absolute measurement of a radiated field.

Radio End Point: physical grouping that contains one radio transmitter/receiver, fixed or portable.

NOTE 13: A Radio End Point may operate only as a receiver or only as a transmitter.

Radio Fixed Part (RFP): one physical sub-group of a FP that contains all the Radio End Points (one or more) that are connected to a single system of antennas.

simplex bearer: MAC layer service that is created using one physical channel.

TDMA frame: time-division multiplex of 10 ms duration, containing 24 successive full slots
A TDMA frame starts with the first bit period of full slot 0 and ends with the last bit period of full slot 23.

test laboratory: body which performs conformance testing
This laboratory is accredited to perform 3rd party testing.

test load: test load is a substantially non-reactive, non-radiating power attenuator which is capable of safely dissipating the power from the transmitter(s)

UMTS: Universal Mobile Telecommunications System

Upper Tester (UT): logical grouping that controls the EUT when under test.

NOTE 14: Commands are sent from the LT to the UT to place the EUT in the appropriate test mode.

3.2 Symbols

There are no special symbols used in the present document.

3.3 Abbreviations

For the purposes of the present document, the following abbreviations apply:

ARI	Access Rights Identity
BER	Bit Error Ratio
CCFP	Call Control Fixed Part
CI	Common Interface
CTA	Cordless Terminal Adapter
CTM	Cordless Terminal Mobility
CW	Continuous Wave
dBm	dB relative to 1 mW
EMC	Electro-Magnetic Compatibility
emf	electro-motive force
ERP	Effective Radiated Power
EUT	Equipment Under Test
FER	Frame Error Ratio
FP	Fixed Part
FT	Fixed radio Termination
GPS	Global Positioning System
HyP	Hybrid Part
IMT-FT	International Mobile Telecommunications, FDMA/TDMA
IPEI	International Portable part Equipment Identity
ISDN	Integrated Services Digital Network
ITE	Information Technology Equipment
LT	Lower Tester
LV	Low Voltage
NTP	Normal Transmitted Power
PHL	Physical
PIXIT	Protocol Implementation Extra Information for Testing
P_{NTP}	Maximum transmit power per simultaneously active transceiver
PP	Portable Part
ppm	parts per million
PSN	Portable equipment Serial Number
PT	Portable radio Termination
R&TTE	Radio and Telecommunications Terminal Equipment
RF	Radio Frequency
RFP	Radio Fixed Part
RFPI	Radio Fixed Part Identity
RH	Relative Humidity
TSM	Test Standby Mode
TSP	Test Support Profile
UT	Upper Tester
VSWR	Voltage Standing Wave Ratio
WRS	Wireless Relay Station

4 Technical requirements specifications

4.1 Environmental profile

The technical requirements of the present document apply under the environmental profile for operation of the equipment, which shall be declared by the supplier. The equipment shall comply with all the technical requirements of the present document at all times when operating within the boundary limits of the required operational environmental profile.

4.2 Document layout

The test cases described in these clauses are intended to follow the ISO/IEC 9646-1 [8] recommendations as closely as possible. However, for practical reasons it is not always possible to follow the guide-lines exactly and the following clauses describe the relationship of the present document to ISO/IEC 9646-1 [8].

4.2.1 Test suites

The term "(conformance) test suite" is defined in ISO/IEC 9646-1 [8] clause 3.3.

Table 1 lists the test suite that is described in the present document and the test groups that are associated with it.

Table 1: Test suite

Test suite	Test groups
DECT Physical layer (PHL)	PHL layer services
	Transmission of physical packets
	Reception of physical packets
	Synchronization
	Equipment identities
	Efficient use of radio spectrum
	WRS
	PP to PP communication
	Direct communication
	Higher level modulation

4.2.2 Test groups

The term "test group" is defined in ISO/IEC 9646-1 [8] clause 3.3.

Table 2 lists the test groups that are described in the present document and the test cases that are associated with them.

Table 2: Test groups

Test group	Test cases
Physical layer services	1 2 4
Transmission of physical packets	5 6 7 8 9 10 11 12
Reception of physical packets	13 14 15 16 17 18 19
Synchronization	20
Equipment identities	21
Efficient use of radio spectrum	22
WRS	23
PP to PP communication	24
Direct communication	25
Higher level modulation	26

4.2.3 Test cases

The term "test case" is defined in ISO/IEC 9646-1 [8] clause 3.3.

Table 3 lists the test cases that are described in the present document.

Table 3: Test cases

Test Case	Test case	Clause / clause Number
1	Accuracy and stability of RF carriers	4.5.2
2	Timing jitter: slot-slot on the same channel	4.5.3
3	Reference timing accuracy of a RFP	4.5.3
4	Measurement of packet timing accuracy	4.5.3
5	Transmission Burst	4.5.4
6	Transmitted power: PP and RFP with an integral antenna	4.5.5.1.1
7	Transmitted power: PP and RFP with an external antenna connector	4.5.5.1.2
8	RF carrier modulation	4.5.6
9	Emissions due to modulation	4.5.7.2
10	Emissions due to transmitter transients	4.5.7.3
11	Emissions due to intermodulation	4.5.7.4
12	Spurious emissions when allocated a transmit channel	4.5.7.5
13	Radio receiver sensitivity	4.5.8.1
14	Radio receiver reference bit error ratio	4.5.8.2
15	Radio receiver interference performance	4.5.8.3
16	Radio receiver blocking case 1	4.5.8.4
17	Radio receiver blocking case 2	4.5.8.5
18	Receiver intermodulation performance	4.5.8.6
19	Spurious emissions when the radio endpoint has no allocated transmit channel	4.5.8.7
20	Synchronization port	4.5.9
21	Equipment identity verification/safeguards	4.5.10
22	Efficient use of radio spectrum	4.5.11
23	WRS	4.5.12
24	PP to PP communication	4.5.13
25	Direct communication	4.5.14
26	Higher level modulation	4.5.15

Annex A provides a summary of the essential requirement articles of the R&TTE Directive, [1] justifying the test cases of the present document.

4.3 Applicant's declaration

The applicant shall declare the band edge limits FL and FU and the carriers supported by the EUT (see clauses 4.5.1 and annex F).

Where parameters, capabilities, etc., are subject to applicant's declaration, it shall be the applicant's responsibility to supply a declaration of implementation, in which the applicant explicitly affirms the implementation in the equipment of certain parameters and capabilities.

4.4 Applicability of essential test suites

4.4.1 Introduction

The applicability of the individual essential test suites in the present document is dependent on the type of equipment. The following clauses list the applicable essential test suites. Equipment may contain one or more of the features listed in the following clauses. It is assumed that all equipment contains a radio receiver. The essential test suites described in the present document shall only be applied to the equipment physically containing a DECT RF receiver and/or transceiver. Control lines to the EUT necessary for its operation shall be permitted.

4.4.2 Equipment that includes only a DECT RF receiver

The essential test suite specified in clause 4.5.8 shall be applied.

4.4.3 Equipment that includes a radio transmitter

The essential test suites contained in clauses 5.3.2, 5.3.3, 5.3.4, 5.3.5, 5.3.6, 5.3.7, 5.3.8 and 5.3.11 shall be applied. For equipment continuously transmitting (e.g. FP with dummy bearer) the essential test suite specified in clause 5.3.8.7 shall not apply.

4.4.4 CTAs

The requirements for PPs apply to Cordless Terminal Adapters, CTAs.

4.4.5 Equipment with a synchronization port

The essential test suites contained in clause 5.3.9 shall be applied.

4.4.6 Equipment incorporating the IPEI (PPs only)

The essential test suite contained in clause 5.3.11.1 shall be applied.

4.4.7 All FP equipment

The essential test suite contained in clause 5.3.10.2 shall be applied.

4.4.8 Equipment with combined FT and PT functionality

4.4.8.1 Introduction

Equipment that is able to operate both as an RFP and as a PP shall generally meet the conformance requirements of the present document for an RFP when operating as an RFP and for a PP when operating as a PP.

There are however three basic types of equipment with combined FT and PT functionality using a single common radio, which have been standardized. The notations for these types of equipment are Wireless Relay Stations, WRSs, see EN 300 700 [10], Direct PP to PP communication, see EN 300 175-3 [5], annex G, and Distributed Communications, see EN300 175-5 [6], annex I. For these the following requirements apply:

4.4.8.2 Wireless Relay Station

Wireless Relay Stations, WRSs, see EN 300 700 [10], provide relaying between FT and PT operating simultaneously. A WRS belongs to a specific DECT system, and has to be registered and locked to this system to operate.

WRSs shall conform to the requirements of clause 4.5.12.

NOTE: Conformance to clause 4.5.12 is also relevant for telephony applications. A WRS conforms to a defined frame multiplexing scheme, see EN 300 700 [10] clauses 5.1.3.2 and 6.1.3.2, which provides a transparent digital bit pipe for the user data, and which automatically provides an acceptable upper bound of the incremental delay introduced by a WRS.

4.4.8.3 Direct PP to PP communication

Direct PP to PP communication, see EN 300 175-3 [5], annex G, is a notation for a PP (or CTA) feature that provides ad hoc networking with specific temporary system ad hoc identities. A PP temporarily switches into FT mode to provide direct access to any of the other PPs of the ad hoc network. There is no requirement or need to being locked to an RFP. Since no RFP is involved in the communication link, direct PP to PP communication only uses half the spectrum compared to normal calls routed via RFPs.

Direct PP to PP communication is only allowed within the block 2 010 MHz to 2 020 MHz intended for European wide self provided applications operating in a self coordinating mode (see ERC/DEC/(99)25 [16]) [16]. The DECT carrier positions within the band 2 010 MHz to 2 020 MHz are positioned between 2 011,392 MHz and 2 018,304 MHz as indicated in annex F.

PPs and CTAs with direct PP to PP communication option shall conform to the requirements of clause 4.5.13.

4.4.8.4 Distributed Communications

Distributed communications, EN 300 175-5 [6], annex I, is a notation for a DECT system feature providing direct links between PPs (or CTAs). Such PPs and CTAs are also called Hybrid Parts, HyP. The HyPs always stay in lock with the DECT system and an RFP is always involved in the direct link connection. Either just by providing the locking and time synchronization, or also by direct involvement in the set up procedure. The main target application is data local networking. Since no RFP is involved in the user communication link, the distributed communications option only uses half the spectrum compared to normal calls routed via RFPs.

PPs and CTAs with distributed communications option, HyPs, shall conform to the requirements of clause 4.5.14.

4.4.9 Provision of 2 Mbit/s services. Equipment that is capable of using 4-level and/or 8-level modulation

Equipment is allowed to use 4-level and/or 8-level modulation in addition to the mandatory 2-level modulation. This will increase the bit rate of single radio DECT equipment by a factor 2 or 3, which allows for 2 Mbit/s services.

Such equipment shall conform to the requirements of clause 4.5.15.

4.4.10 Dual mode handsets

The requirements in this and other Harmonized Standards are not tailored for dual mode, triple mode etc. handsets. It may therefore be impossible for such a handset conform to all requirements of two or more Harmonized Standards. Requirements may be contradictory or become unrealistic. For these cases a pragmatic approach is allowed, where exceptions to full compliance to specific requirements will be allowed, provided the intention of the R&TTE Directive [1] is respected.

4.5 Conformance requirements

4.5.1 General

An EUT will operate on a specific subset of all potential carriers (see clause 4.5.2.1). This subset constitutes a frequency band with a lower band edge F_L MHz and an upper band edge F_U MHz. Various tests under this clause 4.5 are defined for carriers $c = 0, 1, \dots, 9$ as a reference band. In those tests carrier $c=0$ shall generally be exchanged to "the carrier closest to F_U ", carrier $c = 9$ shall generally be exchanged to "the carrier closest to F_L " and carrier $c = 5$ shall generally be exchanged to "one carrier inside the band".

This applies as well, were relevant, to references made to EN 300 175-2 [4].

4.5.2 Accuracy and stability of RF carriers

4.5.2.1 Definition of nominal position of RF carriers

A nominal RF carrier is one whose centre frequency F_g is generated by the formula:

$$F_g = F_0 - g \times 1,728 \text{ MHz}, \text{ where } g \text{ is any integer and where } F_0 = 1\,897,344 \text{ MHz.}$$

RF carriers for IMT-FT applications of DECT shall be placed within the parts of the European UMTS spectrum applicable for TDD operation (see ERC/DEC/(99)25 [16] and ERC/DEC/(00)01 [17]) e.g. within 1900 – 1920 MHz, 1920 MHz to 1980 MHz and/or 2010 MHz to 2025 MHz.

IMT-FT equipment will operate on a subset of all potential carriers. This subset shall be declared by the applicant, see clause 4.5.11.4.

Notations for carriers and the centre frequencies are found in annex G.

4.5.2.2 Limits

At an RFP the transmitted RF carrier frequency corresponding to RF channel c shall be in the range $F_c \pm 50$ kHz at extreme conditions.

At a PP the centre frequency accuracy shall be within ± 50 kHz at extreme conditions either relative to an absolute frequency reference or relative to the received carrier, except that during the first 1 s after the transition from the idle-locked state to the active-locked state the centre frequency accuracy shall be within ± 100 kHz at extreme conditions relative to the received carrier.

NOTE: The above state transition is defined in EN 300 175-3 [5].

The maximum rate of change of the centre frequency at both the RFP and the PP while transmitting, shall not exceed 15 kHz per slot.

4.5.2.3 Conformance

Conformance tests as defined in clause 5.3.2 shall be carried out.

4.5.3 Accuracy and stability of timing parameters

4.5.3.1 Definitions

4.5.3.1.1 Slot structure

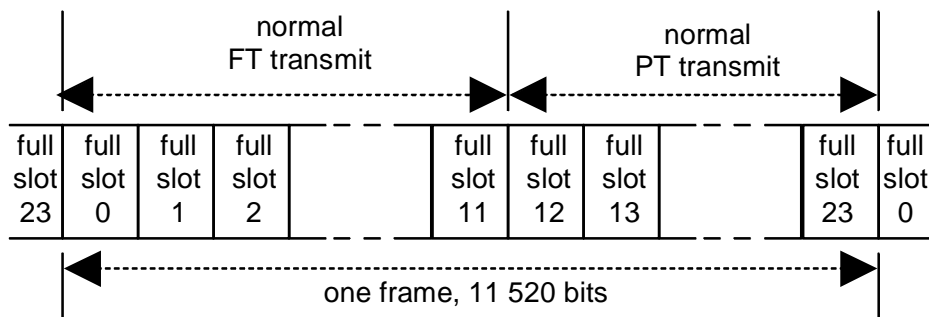

Figure 2: Frame and full-slot structure

Full-slots "K" are numbered from 0 to 23, and half-slots "L" are numbered 0 or 1, where half-slot 0 occurs earlier than half-slot 1. Normally full-slots $K = 0$ to 11 are used in the FT to PT direction, while full-slots $K = 12$ to 23 are normally used in the PT to FT direction.

Each full-slot has a duration of 480 bit intervals. Bit intervals within a full-slot are denoted f_0 to f_{479} where interval f_0 occurs earlier than interval f_1 . Each half-slot has a duration of 240 bit intervals. Half-slots commence at f_0 or f_{240} . See figure 2.

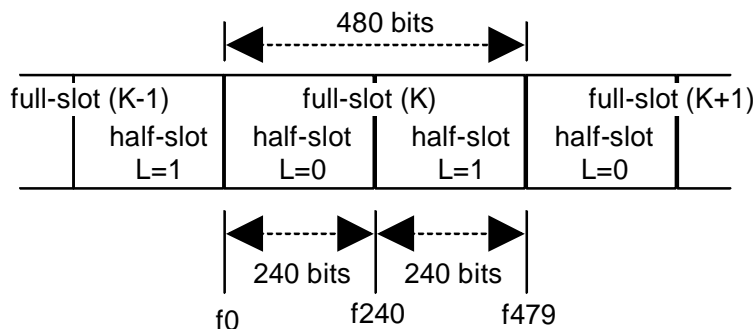

Figure 3: Half-slot format

Each double-slot has a duration of 960 bit intervals. Bit intervals within a double-slot are denoted f_0 to f_{959} . Bits f_0 to f_{479} coincide with the same notation for full-slots with even K , $K(e)$.

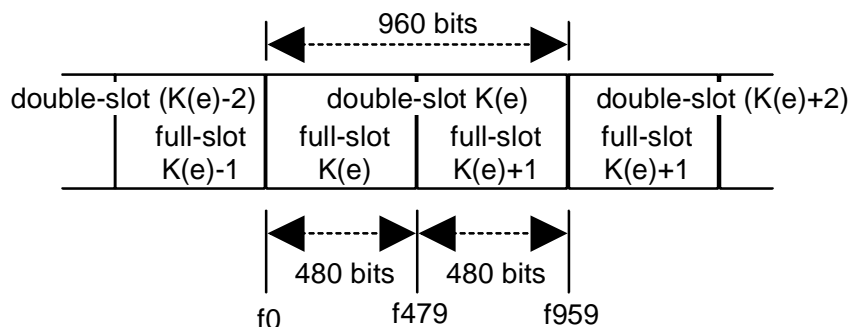

Figure 4: Double-slot format

4.5.3.1.2 Definition of the position of p_0

The start of bit p_0 is defined to occur at the point in time 16 bit periods before the instant at which the modulated carrier passes through the nominal channel frequency immediately prior to the deviation corresponding to the first bit of the packet synchronization word for the EUT as defined in EN 300 175-2 [4], clause 4.6, of for a PT or FT. A method shall be used for the determination of the position of the packet synchronization word which meets the measurement uncertainty stated in clause 5.2. It is not the point at which a receiver determines the presence of p_0 .

4.5.3.2 Limits

4.5.3.2.1 Reference timer accuracy and stability

The reference timer of a RFP or a PP is a notional clock to which the timing parameters of the TDMA framing are related.

A PP shall have its reference timer stability and accuracy better than 25 ppm at extreme conditions.

RFPs that can work with more than one duplex pair of physical channels per frame are known as multi-channel RFPs. Single channel RFPs can only work with one duplex pair of physical channels per frame (excluding handover situations).

A multi channel RFP shall have its reference timer stability and accuracy better than 5 ppm and better than 10 ppm at extreme conditions.

A single channel RFP shall have reference timer stability and accuracy better than 10 ppm at extreme conditions.

4.5.3.2.2 RFP transmission jitter

The nominal time when a packet should occur at the RFP antenna is (by this definition) synchronous to the RFP reference timer.

The jitter of a RFP packet transmission in a slot refers to the occurrence at the antenna of the start of symbol p0 of that packet. The jitter is defined in relation to the reference timer of that RFP.

The jitter of a packet transmission shall be less than $\pm 1 \mu\text{s}$ at extreme conditions.

The jitter between p0 and every other symbol in a packet shall be within $\pm 0,1 \mu\text{s}$.

NOTE: $0,1 \mu\text{s}$ corresponds to 250 ppm.

4.5.3.2.3 PP reference timer synchronization

A PP shall take its reference timer parameters, including half-slot, full-slot, frame, multi-frame and receiver scan (see synchronization, EN 300 175-3 [5]) from any channel of any of the RFPs that it is locked to.

It is allowed (but not required) to have more than one PP reference timer.

The reference timer used for a PP transmission to a RFP shall be synchronized to packets (see clause 4.5.4.1.2) received from that RFP or from a RFP to which internal handover is allowed.

This reference timer for packet transmission timing is nominally (by this definition) synchronized to the time when the last packet used for synchronization occurred at the PP antenna.

When a PP transmits a packet, the start of transmission of symbol p0 of the packet shall occur at the PP antenna $\pm 2 \mu\text{s}$ at extreme conditions from the nominal transmission time as given by an ideal PP reference timer with 0 ppm accuracy. An exception is allowed for a dummy bearer change request packet transmission (see EN 300 175-3 [5], clause 7.2.5.6), when the nominal transmission time shall be given by the actual PP reference timer.

NOTE: The reason for the exception is that a residential PP may need to send the dummy bearer change request after a sudden slot theft in the idle locked mode. In this case the last synchronization of the reference timer can be more than 16 frame old. For all other packet transmissions, including bearer set up, the synchronization is normally less than one frame old.

The jitter between p0 and every other symbol in a packet shall be within $\pm 0,1 \mu\text{s}$.

Connections to different RFPs are allowed (but not required) to have different reference timers.

4.5.3.3 Conformance

Conformance tests as defined in clause 5.3.3 shall be carried out.

4.5.4 Transmission burst

4.5.4.1 Definitions

4.5.4.1.1 Introduction

The transmission requirements are defined in clauses 4.5.4.1.2 to 4.5.4.1.10 and graphically represented in figure 5.

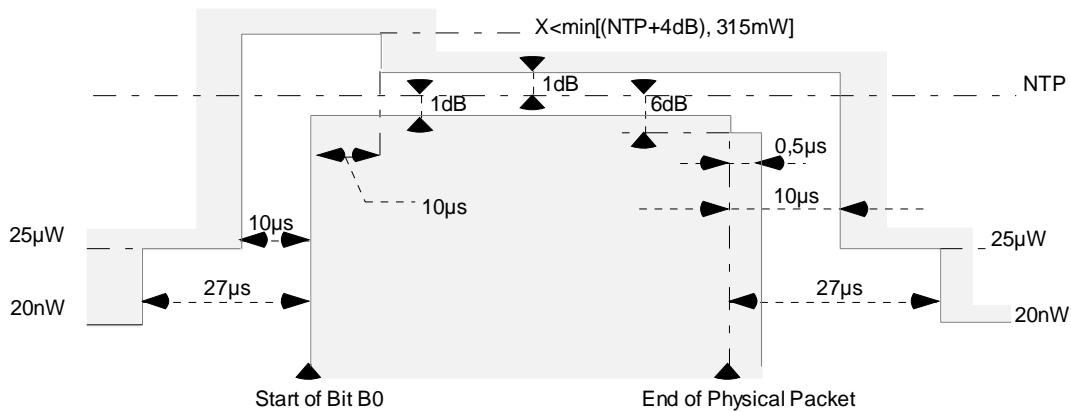

Figure 5: Physical packet power-time template [B0 shall be p0]

4.5.4.1.2 Physical packets

The term "physical packet" used in the present document refers to all the bits transmitted by the DECT Radio End Point in one slot time. The timing of the physical packet relative to the power-time template shall be conditioned by the absolute packet timing measurement uncertainty in clause 5.2.

4.5.4.1.3 Transmitted power

This is the mean power delivered over one radio frequency cycle.

4.5.4.1.4 Normal Transmitted Power (NTP)

The NTP is the transmitted power averaged from the start of bit p0 of the physical packet to the end of the physical packet.

4.5.4.1.5 Transmitter attack time

This is the time taken for the transmitted power to increase from 25 µW to the time that the first bit of the physical packet, p0, starts transmission.

4.5.4.1.6 Transmitter release time

This is the time, taken from the end of the physical packet, for the transmitted power to decrease to 25 µW.

4.5.4.1.7 Minimum power

The lowest transmitted power measured from bit p0 to the end of the physical packet.

4.5.4.1.8 Maximum power

The maximum power is defined to cover both the ramp-up and ramp-down of the transmission of a physical packet to which individual limits apply:

- The highest transmitted power measured from 10 µs after bit p0 to 10 µs after the end of the physical packet.
- The highest transmitted power measured from 10 µs before bit p0 to 10 µs after p0 of the physical packet.

4.5.4.1.9 Maintenance of transmission after packet end

This is defined as the transmitted power up to 0,5 µs after the end of the physical packet.

4.5.4.1.10 Transmitter idle power output

The transmitter idle power output is defined as the power output during the time period starting 27 μ s after the end of the physical packet and finishing 27 μ s before p0 of the next physical packet.

4.5.4.2 Limits

4.5.4.2.1 Transmitter attack time

The transmitter attack time shall be less than 10 μ s at extreme conditions.

4.5.4.2.2 Transmitter release time

The transmitter release time shall be less than 10 μ s at extreme conditions.

4.5.4.2.3 Minimum power

From the first symbol of the packet, p0, to the end of the physical packet, the transmitted power shall be greater than (NTP - 1 dB) at extreme conditions.

4.5.4.2.4 Maximum power

- a) From 10 μ s after the start of symbol p0 to 10 μ s after the end of the physical packet, the transmitted power shall be less than (NTP + 1 dB) at extreme conditions.
- b) From 10 μ s before the start of symbol p0 to 10 μ s after the start of symbol p0, the transmitted power shall be less than (NTP + 4 dB) and less than 315 mW at extreme conditions.

4.5.4.2.5 Maintenance of transmission after packet end

The transmitted power shall be maintained greater than (NTP - 6 dB) for 0,5 μ s after the end of the physical packet at extreme conditions.

4.5.4.2.6 Transmitter idle power output

For the time period starting 27 μ s after the end of the physical packet and finishing 27 μ s before the next transmission of a data symbol p0, the transmitter idle power shall be less than 20 nW, except when p0 of the next transmitted packet occurs less than 54 μ s after the end of the transmitted physical packet.

4.5.4.3 Conformance

Conformance tests as defined in clause 5.3.4 shall be carried out.

4.5.5 Transmitted power

4.5.5.1 Definitions

4.5.5.1.1 PP and RFP with an integral antenna

The NTP shall be less than P_{NTP} per simultaneously active transceiver at nominal conditions.

The power measured at a temporary connector is the NTP.

4.5.5.1.2 PP and RFP with external connections for all antennas

For a radio end point with more than one antenna port, the instantaneous power from each antenna port shall be added together to give the NTP.

The NTP shall be less than P_{NTP} per simultaneously active transceiver.

4.5.5.1.3 PP and RFP with both integral and external antennas

If the integral and external antennas are not transmitting simultaneously then the test cases described in clauses 5.3.5.1 and 5.3.5.2 shall be applied independently. The appropriate antenna is selected using the test message referenced in clause 5.1.10.3.

If the integral and external antennas are transmitting simultaneously then both clauses 5.3.5.1 and 5.3.5.2 shall be applied and the results shall be added to give the NTP.

4.5.5.2 Limits

P_{NTP} is 250 mW, equal to 24 dBm.

The antenna gain of integral antennas shall be less than $12 + X$ dBi. X is the difference in dB between 24 dBm and the NTP expressed in dB for any one active transceiver.

4.5.5.3 Conformance

Conformance tests as defined in clause 5.3.5 shall be carried out.

4.5.6 RF carrier modulation

4.5.6.1 Definition

The modulation method shall be Gaussian Frequency Shift Keying, (GFSK), with a bandwidth-bit period product of nominally 0,5 and a nominal peak deviation (f) of be 288 kHz..

A binary "1" is encoded with a peak frequency deviation of (+f), giving a peak transmit frequency of ($F_c + f$), which is greater than the carrier frequency of (F_c). A binary "0" is encoded with a peak frequency deviation of (-f), giving a peak transmit frequency of ($F_c - f$).

4.5.6.2 Limits

The achieved deviation in any given PP or RFP may vary from this nominal value as follows:

NOTE 1: These limits apply equally to positive and negative deviations.

Case A: Case A shall apply to the transmission of a repeating binary sequence of four "1"s and four "0"s:

....000011110000111100001111....

The deviation limits for case A shall be:

- peak deviation greater than 259 kHz (90 % of nominal);
- peak deviation less than 403 kHz (140 % of nominal).

Case B: Case B shall apply to the transmission of all other binary sequences (sequences both longer and shorter than case A) that contain a maximum "digital sum variation" (see note 2) with an absolute value equal to or less than sixty four.

The deviation limits for case B shall be:

- peak deviation greater than 202 kHz (70 % of nominal);
- peak deviation less than 403 kHz (140 % of nominal).

NOTE 2: Case B includes the case of a ".1010." sequence.

NOTE 3: "Digital Sum Variation" (DSV) is defined as the cumulative total of all transmitted symbols, counted from the start of the transmission burst. A binary "1" counts as (+1); a binary "0" as (-1). The DSV total indicates the cumulative DC balance of the transmitted symbols.

4.5.6.3 Conformance

Conformance tests as defined in clause 5.3.6 shall be carried out.

4.5.7 Unwanted RF power radiation

4.5.7.1 General

If the EUT is equipped with antenna diversity, the EUT shall have the diversity operation defeated for the following tests (see clause 5.1.10.3 for the appropriate test message reference).

4.5.7.2 Emissions due to modulation

4.5.7.2.1 Definition

The unwanted emission(s) due to modulation is the power measured in any DECT RF channel other than the one in which the EUT is transmitting, integrated over a bandwidth of 1 MHz.

4.5.7.2.2 Limits

With transmissions on physical channel Ra (K,L,M,N) in successive frames, the power in physical channel Ra (K,L,Y,N) shall be less than the values given in table 4.

Table 4: Emissions modulation

Emissions on RF channel "Y"	Maximum power level
Y = M \pm 1	160 μ W
Y = M \pm 2	1 μ W
Y = M \pm 3	80 nW
Y = any other DECT channel	40 nW
NOTE: For Y = "any other DECT channel", the maximum power level shall be less than 40 nW except for one instance of a 500 nW signal.	

The power in RF channel Y is defined by integration over a bandwidth of 1 MHz centred on the nominal centre frequency, F_y , averaged over at least 60 % but less than 80 % of the physical packet, and starting before 25 % of the physical packet has been transmitted but after the synchronization word.

4.5.7.2.3 Conformance

Conformance tests as defined in clause 5.3.7 shall be carried out.

4.5.7.3 Emissions due to transmitter transients

4.5.7.3.1 Definition

The power level of all modulation products (including AM components due to the switching on or off of the modulated RF carrier) in a DECT RF channel as a result of a transmission on another DECT RF channel.

4.5.7.3.2 Limits

The power level of all modulation products (including Amplitude Modulation (AM) products due to the switching on or off of a modulated RF carrier) arising from a transmission on RF channel M shall, when measured using a peak hold technique, be less than the values given in table 5. The measurement bandwidth shall be 100 kHz and the power shall be integrated over a 1 MHz bandwidth centred on the DECT frequency, F_y .

Table 5: Emissions due to transmitter transients

Emissions on RF channel "Y"	Maximum Power level
$Y = M \pm 1$	250 μ W
$Y = M \pm 2$	40 μ W
$Y = M \pm 3$	4 μ W
Y = any other DECT channel	1 μ W

4.5.7.3.3 Conformance

Conformance tests as defined in clause 5.3.7 shall be carried out.

4.5.7.4 Emissions due to intermodulation

4.5.7.4.1 Definition

The power level of intermodulation products that are on any DECT physical channel when any combination of the transmitters at a radio FP or portable part are in calls on the same slot on different frequencies.

4.5.7.4.2 Limits

The power level of intermodulation products that are on any DECT physical channel when any combination of the transmitters at a radio end point are in calls on the same slot on different frequencies shall be less than 1 μ W. The power level is defined by integration over the 1 MHz centred on the nominal centre frequency of the afflicted channel and averaged over the time period in clause 4.5.7.2.2.

4.5.7.4.3 Conformance

Conformance tests as defined in clause 5.3.7 shall be carried out.

4.5.7.5 Spurious emissions when allocated a transmit channel

4.5.7.5.1 Definition

The peak power level of any RF emissions outside the radio frequency band allocated to DECT when a radio endpoint has been allocated a transmit channel. If a Radio End Point has more than one transceiver, any out of band transmitter intermodulation products shall also be included.

The limits and conformance requirements cover two kinds of emissions, radiated and conducted spurious emissions.

4.5.7.5.2 Limits

The peak power level of any RF emissions outside the radio frequency band allocated to DECT, as described in annex F, when a radio end point has an allocated physical channel, shall not exceed 250 nW at frequencies below 1 GHz and 1 μ W at frequencies above 1 GHz. The power shall be defined in the bandwidths given in table 6. If a radio end point has more than one transceiver, any out of band transmitter intermodulation products shall also be within these limits.

Table 6: Spurious emissions

Frequency offset, f_o From edge of band	Measurement bandwidth
$0 \text{ MHz} \leq f_o < 2 \text{ MHz}$	30 kHz
$2 \text{ MHz} \leq f_o < 5 \text{ MHz}$	30 kHz
$5 \text{ MHz} \leq f_o < 10 \text{ MHz}$	100 kHz
$10 \text{ MHz} \leq f_o < 20 \text{ MHz}$	300 kHz
$20 \text{ MHz} \leq f_o < 30 \text{ MHz}$	1 MHz
$30 \text{ MHz} \leq f_o < 12,75 \text{ GHz}$	3 MHz

Measurements shall not be made for transmissions on the RF channel closest to the nearest band edge for frequency offsets of up to 2 MHz.

In addition, not regarding up to 2 instances of a continuous-wave spurious signal for PPs for which the total peak power level shall be less than 250 nW as measured in a 3 MHz measurement bandwidth, the peak power level shall be less than 20 nW in a 100 kHz measuring bandwidth for the following broadcast bands:

- 47 MHz to 74 MHz;
- 87,5 MHz to 108 MHz;
- 108 MHz to 118 MHz;
- 174 MHz to 230 MHz;
- 470 MHz to 862 MHz.

4.5.7.5.3 Conformance

Conformance tests as defined in clause 5.3.7 shall be carried out.

4.5.8 Radio receiver testing

4.5.8.1 Radio receiver sensitivity

4.5.8.1.1 Definition

The radio receiver sensitivity is defined as the power level at the receiver input at which the Bit Error Ratio (BER) is 0,001. The radio receiver sensitivity shall be 60 dB μ V/m (-83 dBm) or better.

4.5.8.1.2 Limits

The radio receiver sensitivity is defined as the power level at the receiver input at which the Bit Error Rate (BER) is 0,001 in the D-field.

The radio receiver sensitivity shall be -83 dBm (i.e. 60 dB μ V/m), or better. This limit shall be met for a reference DECT radio end point transmitted frequency error of ± 50 kHz for PPs and RFPs.

This requirement shall be met with the radio end point under test operating in time division duplex mode with a reference DECT radio end point.

Before using a DECT physical channel for transmission or reception, the receiver shall be able to measure the strength of signals on that physical channel, that are received stronger than -93 dBm (i.e. 50 dB μ V/m) and weaker than -33 dBm (i.e. 110 dB μ V/m) with a resolution of better than 6 dB. Signals that are received weaker than -93 dBm shall produce a result equal to, or less than that produced by a signal of -93 dBm. Signals that are received stronger than -33 dBm shall produce a result equal to, or greater than that produced by a signal of -33 dBm.

4.5.8.1.3 Conformance

Conformance tests as defined in clause 5.3.8 shall be carried out.

4.5.8.2 Radio receiver reference BER and FER

4.5.8.2.1 Definition

The radio receiver reference BER and FER is the maximum allowed BER and FER for a power level at the receiver input of -73 dBm or greater (i.e. 70 dB μ V/m).

4.5.8.2.2 Limits

The radio receiver reference bit error rate and frame error ratio is the maximum allowed bit error rate and frame error ratio for a power level at the receiver input of -73 dBm or greater (i.e. 70 dB μ V/m).

The reference bit error rate is 0,00001 in the D-field. The reference frame error ratio is 0,0005.

4.5.8.2.3 Conformance

Conformance tests as defined in clause 5.3.8 shall be carried out.

4.5.8.3 Radio receiver interference performance

4.5.8.3.1 Definition

The ability of DECT equipment to continue receiving in the presence of an interfering signal on the same or different DECT RF channel.

4.5.8.3.2 Limits

With a received signal strength of -73 dBm (i.e. 70 dB μ V/m) on RF channel M, the BER in the D-field shall be maintained better than 0,001 when a modulated, reference DECT interferer of the indicated strength is introduced on the DECT RF channels shown in table 7.

Table 7: Receiver interference performance

Interferer on RF channel "Y":	Interferer signal strength	
	(dB μ V/m)	(dBm)
Y =M	59	-84
Y =M \pm 1	83	-60
Y =M \pm 2	104	-39
Y =any other DECT channel	110	-33
NOTE: The RF carriers "Y" shall include the three nominal DECT RF carrier positions immediately outside each edge of the DECT band.		

4.5.8.3.3 Conformance

Conformance tests as defined in clause 5.3.8 shall be carried out.

4.5.8.4 Radio receiver blocking case 1: owing to signals occurring at the same time but on other frequencies

4.5.8.4.1 Definition

The receiver should work in the presence of strong signals on other frequencies. These interferers may be modulated carriers or single continuous - wave carriers.

4.5.8.4.2 Limits

The receiver should work in the presence of strong signals on other frequencies. These interferers may be modulated carriers or single frequency signals. The operation in the presence of DECT modulated signals has been described in clause 4.5.8.3.

With the desired signal set at -80 dBm, the BER shall be maintained below 0,001 in the D-field in the presence of any one of the signals shown in table 8.

The receiver shall operate on a frequency band allocation with the low band edge F_L MHz and the high band edge F_U MHz.

Table 8: Receiver blocking

Frequency (f)	Continuous wave interferer level	
	For radiated measurements dB μ V/m	For conducted measurements dBm
$25 \text{ MHz} \leq f < F_L - 100 \text{ MHz}$	120	-23
$F_L - 100 \text{ MHz} \leq f < F_L - 5 \text{ MHz}$	110	-33
$ f - F_C > 6 \text{ MHz}$	100	-43
$F_U + 5 \text{ MHz} < f \leq F_U + 100 \text{ MHz}$	110	-33
$F_U + 100 \text{ MHz} < f \leq 12,75 \text{ GHz}$	120	-23

For the basic DECT frequency band allocation F_L is 1 880 MHz and F_U is 1 900 MHz. Receivers may support additional carriers, e.g. up to $F_U = 1 920$ MHz.

4.5.8.4.3 Conformance

Conformance tests as defined in clause 5.3.8 shall be carried out.

4.5.8.5 Radio receiver blocking case 2: owing to signals occurring at a different time

4.5.8.5.1 Definition

When a high level interferer is present in a physical channel other than the one the receiver is on, the receiver is able to continue receiving the desired signal.

4.5.8.5.2 Limits

With a signal of strength -14 dBm (i.e. 129 dB/ μ Vm) incident on the receiver in slot "N" on RF carrier "M", the receiver shall be able to receive at -83 dBm, and with the BER in the D-field maintained better than 0,001, on slot (N + 2) modulo 24 on any DECT RF carrier.

4.5.8.5.3 Conformance

Conformance tests as defined in clause 5.3.8 shall be carried out.

4.5.8.6 Receiver intermodulation performance

4.5.8.6.1 Definition

With a call set-up on a particular physical channel, two interferers are introduced so that they can produce an intermodulation product on the physical channel already in use.

4.5.8.6.2 Limits

With a call set up on a particular physical channel, two interferers are introduced so that they can produce an intermodulation product on the physical channel already in use.

If RF carrier number "d" is in use, a reference DECT interferer and a continuous wave interferer are introduced on DECT carriers "e" and "f" to produce an intermodulation product on carrier "d". Neither "e" nor "f" shall be adjacent to "d".

The received level of carriers "e" and "f" shall be -48 dBm and the received level of carrier "d" shall be -80 dBm.

With "e" and "f" being received 33 dB greater than "d", and "d" being received at -80 dBm, the receiver shall still operate with a BER of less than 0,001 in the D-field.

4.5.8.6.3 Conformance

Conformance tests as defined in clause 5.3.8 shall be carried out.

4.5.8.7 Spurious emissions when the PP has no allocated transmit channel

4.5.8.7.1 Definition

The power level of any spurious emission when the PP has not been allocated a transmit channel.

4.5.8.7.2 Limits

4.5.8.7.2.1 Out of band

The power level of any spurious emissions when the radio end point has no allocated transmit channel shall not exceed 2 nW between 30 MHz and 1 GHz. Between 1 GHz and 12,75 GHz the power level shall not exceed 20 nW.

The power shall be measured using a peak hold technique with a 100 kHz measurement bandwidth.

4.5.8.7.2.2 In the DECT band

The power level of any spurious emissions within the DECT band shall not exceed 2 nW measured in a 1 MHz bandwidth. The following exceptions are allowed:

- a) in one 1 MHz band, the maximum allowable Effective Radiated Power (ERP) shall be less than 20 nW;
- b) in up to two bands of 30 kHz, the maximum ERP shall be less than 250 nW.

4.5.8.7.3 Conformance

Conformance tests as defined in clause 5.3.8 shall be carried out.

4.5.9 Intersystem synchronization (FP only)

4.5.9.1 Description

The (optional) intersystem synchronization allows adjacent DECT FPs to achieve frame synchronization.

Two classes of synchronization are specified:

Class 1: guard band alignment, no handover between FPs.

Class 2: guard band alignment, handover between FPs.

The requirements of handover result in different timing tolerances between the two classes.

Synchronization output ports generate a sequence of synchronization pulses, one pulse for each 10ms frame. The synchronization pulse is positive (true) logic. The voltage levels of the pulse corresponds to those defined in ITU-T Recommendation V.11 [9].

A time delay T_d is defined as the time from the falling edge of the synchronization pulse to the start bit p0 of slot 0 occurring at the antenna of an RFP belonging to a synchronized FP, master or slave.

There are two conceptually different ways to provide the intersystem synchronization. One is where one system acts as reference (master) for an other system, and the other is when the systems independently use Global Positioning System, GPS, radio signals as their common reference. Limits and conformance apply for the following items:

- Wired synchronization ports: FP as a master and/or FP as a slave;
- GPS synchronization: FP with integrated GPS synchronization or external GPS synchronization device.

4.5.9.2 Wired synchronization ports

4.5.9.2.1 FP as a master

4.5.9.2.1.1 Limits

The time delay T_d , pulse widths, and output port characteristics shall meet the following limits:

- a) the width of the synchronization pulse as measured shall be between 2 and 5 ms for frame 0 and between 5 μ s and 1 ms for all other frames;
- b) T_d as measured shall be 15 μ s \pm 5 μ s for class 1 FPs;
- c) T_d as measured shall be 15 μ s \pm 2 μ s for class 2 FPs;
- d) the synchronization port characteristics shall not exceed the limits stated in ITU-T Recommendation V.11 [11] clauses 5.2.1, 5.2.2 and 5.3.
- e) the transition times of the synchronization pulse from the 10 % to 90 % points and from the 90 % to 10 % points shall not exceed 120 ns when measured into a 100 ohm \pm 10 % load;

4.5.9.2.1.2 Conformance

Conformance tests as defined in clause 5.3.9.2.1 shall be carried out.

4.5.9.2.2 FP as a slave

4.5.9.2.2.1 Limits

A synchronization pulse, in conformance with the limits specified for master FPs, shall be connected to the synchronization input port of the slave EUT, whereby the time delay T_d and input port characteristics shall meet the following limits:

- a) The time delay T_d as measured shall be within 15 μ s \pm 5 μ s for class 1 FPs; and within 15 μ s \pm 2 μ s for class 2 FPs.
- b) The input port characteristics shall not exceed the limits specified in ITU-T Recommendation V.11 [9] clauses 6.2, 6.3 and 6.4.

4.5.9.2.2.2 Conformance

Conformance tests as defined in clause 5.3.9.2.2 shall be carried out.

4.5.9.3 GPS synchronization

4.5.9.3.1 FP with integrated Global Positioning System (GPS) synchronization

4.5.9.3.1.1 Limits

A virtual ideal sequence of synchronization pulses is used as a reference to define the limits for an FP with integrated GPS synchronization. These reference pulses fulfill the requirements of clause 4.5.9.2.1 a), and furthermore the falling edge of the reference synchronization pulse for a frame 0 does coincide with $T_{\text{GPS}} \bmod 4 = 0$, where T_{GPS} is the GPS time in seconds.

The time delay T_d related to these reference synchronization pulses shall meet the following limits:

- a) T_d as measured shall be $15 \mu\text{s} \pm 5 \mu\text{s}$ for class 1 FPs;
- b) T_d as measured shall be $15 \mu\text{s} \pm 2 \mu\text{s}$ for class 2 FPs;
- c) If the EUT at the same time is a master (providing a synchronization output port) it shall also fulfill the requirements of clause 4.5.9.2.1;

4.5.9.3.1.2 Conformance

Conformance tests as defined in clause 5.3.9.3.1 shall be carried out.

4.5.9.3.2 External GPS synchronization device

4.5.9.3.2.1 Limits

A virtual ideal sequence of synchronization pulses is used as a reference to define the limits for an external GPS synchronization device. These reference pulses fulfill the requirements of clause 4.5.9.2.1 a), and furthermore the falling edge of the reference synchronization pulse for a frame 0 does coincide with $T_{\text{GPS}} \bmod 4 = 0$, where T_{GPS} is the GPS time in seconds.

Pulse widths, output port characteristics and timing accuracy in relation to the reference synchronization pulses shall meet the following limits:

- a) the width of the synchronization pulse as measured shall be between 2 and 5 ms for frame 0 and between $5 \mu\text{s}$ and 1 ms for all other frames;
- b) the synchronization port characteristics shall not exceed the limits stated in ITU-T Recommendation V.11 [9] clauses 5.2.1, 5.2.2 and 5.3;
- c) the transition times of the synchronization pulse from the 10 % to 90 % points and from the 90 % to 10 % points shall not exceed 120 ns when measured into a $100 \Omega \pm 10 \%$ load;
- d) the synchronization pulses of the output port shall be frame and frame number synchronized to the reference synchronization pulses.
- e) the timing accuracy between the falling edge of a synchronization pulse of the output port and the falling edge of the reference pulse shall be $s \pm 5 \mu\text{s}$ for class 1 FPs;
- f) the timing accuracy between the falling edge of a synchronization pulse of the output port and the falling edge of the reference pulse shall be $s \pm 2 \mu\text{s}$ for class 2 FPs;

4.5.9.3.2.2 Conformance

Conformance tests as defined in clause 5.3.9.3.2 shall be carried out.

4.5.10 Equipment identity testing

4.5.10.1 PP

This clause describes the protection requirements of the mandatory IPEI (International Portable Equipment Identity) equipment code. For information on the procurement and coding of the IPEI, refer to EN 300 175-6 [7] clause 10.

The applicant shall declare that it is not possible for the user to alter the IPEI using any normally accessible procedure.

The applicant shall supply, in addition to the equipment, sufficient means in the equipment with instructions in the documentation to permit validation of the equipment manufacturer's code and verification of the existence of the Portable equipment Serial Number (PSN) code in the equipment.

4.5.10.2 FP

The applicant shall declare that:

- DECT FPs which do not transmit the TA escape message transmits the N_T message as defined in EN 300 175-3 [5] clause 7.2.2 at least once every 10 s on all active physical channels;
- these N_T identity messages are transmitted with the appropriate A-field header code as defined in EN 300 175-3 [5] clause 7.1.2 and the N_T message contains an ETSI distributed code as defined in EN 300 175-6 [7] clause 5.

4.5.11 Efficient use of the radio spectrum

4.5.11.1 Channel selection

The applicant shall declare that he conforms to all obligatory conditions in EN 300 175-3 [5], clauses 11.4 and 11.6.

4.5.11.2 Channel confirmation

4.5.11.2.1 For the PT

The applicant shall declare that for the PT:

- the first PT transmission on the newly selected channel shall be made in accordance with the scan sequence of the addressed RFP;
- to continue transmitting on the newly selected physical channel the PT shall receive an indication that the FT is receiving the PT transmissions within 2 frames of the first PT transmission.

4.5.11.2.2 For the FT

The applicant shall declare that for the FT:

- the RFP shall not transmit on more than 2 physical channels for which complementary physical channels do not exist;

Temporarily more than 2 dummy bearers may exist when an RFP has double dummies and dummy bearer hopping is enabled as defined in EN 300 175-3 [5] clause 5.7;

NOTE: A complementary physical channel is a physical channel between the same two radio endpoints which occurs 5 ms before or after the physical channel to which it is complementary.

- the first transmission of an FT, which uses fast connection setup to address a specific PT, shall be made in accordance with the scan sequence of the addressed PT receiver;
- to continue transmitting on the selected physical channel the FT shall receive an indication that the PT is receiving the FT transmissions within 2 frames of the first FT transmission.

4.5.11.3 Channel release

The applicant shall declare that:

- a radio end point shall cease transmission of a bearer on a physical channel and release the bearer if it has not received the correct RFPI, with a correct CRC, on that bearer in the last 10 s;
- a radio end point which transmits on both the physical channel and complementary physical channel shall cease to transmit on the channels if either:
 - a) the receiving endpoint indicates to the transmitting endpoint that transmission shall cease on both these physical channels; or
 - b) the transmitting FT or PT is no longer attempting to receive at least one physical channel from the FT or PT to which it is transmitting.

4.5.11.4 General

For an FT or PT the applicant shall declare:

- that multibearer connections shall only exist in full slot and double slot transmission mode;
- which subset of all potential IMT-FT carriers the EUT is capable of communicating on, and if the EUT also is capable of communicating on DECT RF channels, $c < 10$. See notations annex F.

4.5.12 WRS testing

4.5.12.1 General requirements

The WRS shall be tested as a stand alone PP and shall comply to all relevant PP test cases in the present document. In addition the WRS shall be tested as an RFP as regards the carrier frequency demands of clause 4.5.2 and reference timer accuracy demands of clause 4.5.3 of the present document.

The WRS EUT shall meet the requirements and the applicants declarations as described below.

A WRS requires to be synchronized to a dummy bearer to derive its reference timer for PT and FT transmissions.

4.5.12.2 Testing as a PP

The WRS shall operate as a PP in the test-stand-by mode, TSM, annex C, as a stand alone module.

In this mode it shall be tested as a normal PP with the exception that it shall be tested for the RFP class E2 if it is intended for outdoor use, and that test case 19 is not applicable. See figure 6.

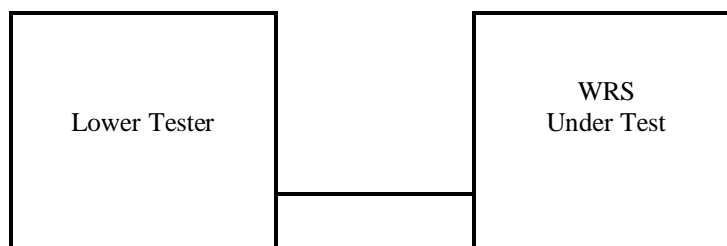

Figure 6: WRS testing as a PP

4.5.12.3 Testing as an RFP

A dummy bearer shall be generated by the Lower Tester or (if that is not possible) by an RFP supplied by the applicant and conforms to the present document. The WRS EUT shall be synchronized to the dummy bearer and shall operate as an RFP in test-stand-by Mode. The dummy bearer may change bearer during the test.

The EUT shall comply with the FT demands of the present document on Reference Timer accuracy, Frequency accuracy, Equipment Identity and Efficient Use of the Radio Spectrum. See figure 7.

NOTE: The power combiner is not needed if the PP and RFP functions have different antenna connectors.

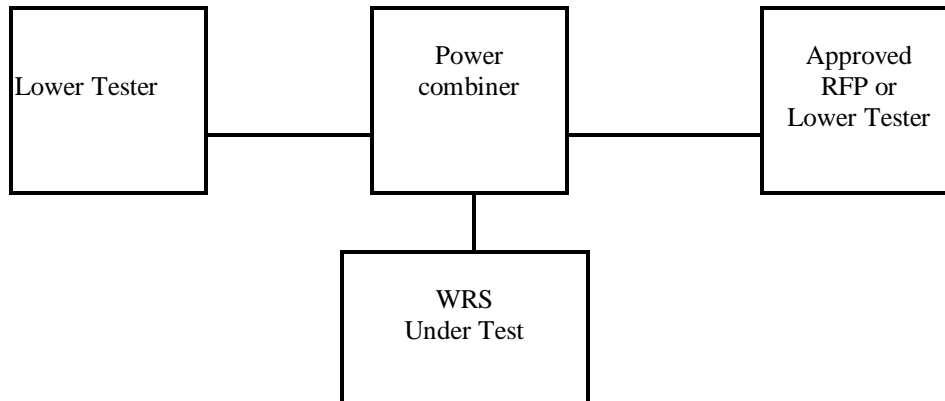

Figure 7: WRS testing as an RFP

4.5.12.4 Additional requirements

- a) The EUT shall provide a mechanism, to control the number of multihops.
 - The WRS that is locked to an FT shall decrease the value HOPS (when > 0) of the corresponding WRS type (CRFP or REP respectively; see clauses 5 and 6 in the received extended fixed part capabilities message (see EN 300 175-3 [5], clause 7.2.3.5.2.1) for the transmission of its own extended fixed part capability information.
- b) The EUT of CRFP type shall apply the following frame multiplexing structure.
 - Figure 8 shows the typical frame multiplexing structure for a CRFP that supports full slots with IN_minimum_delay.

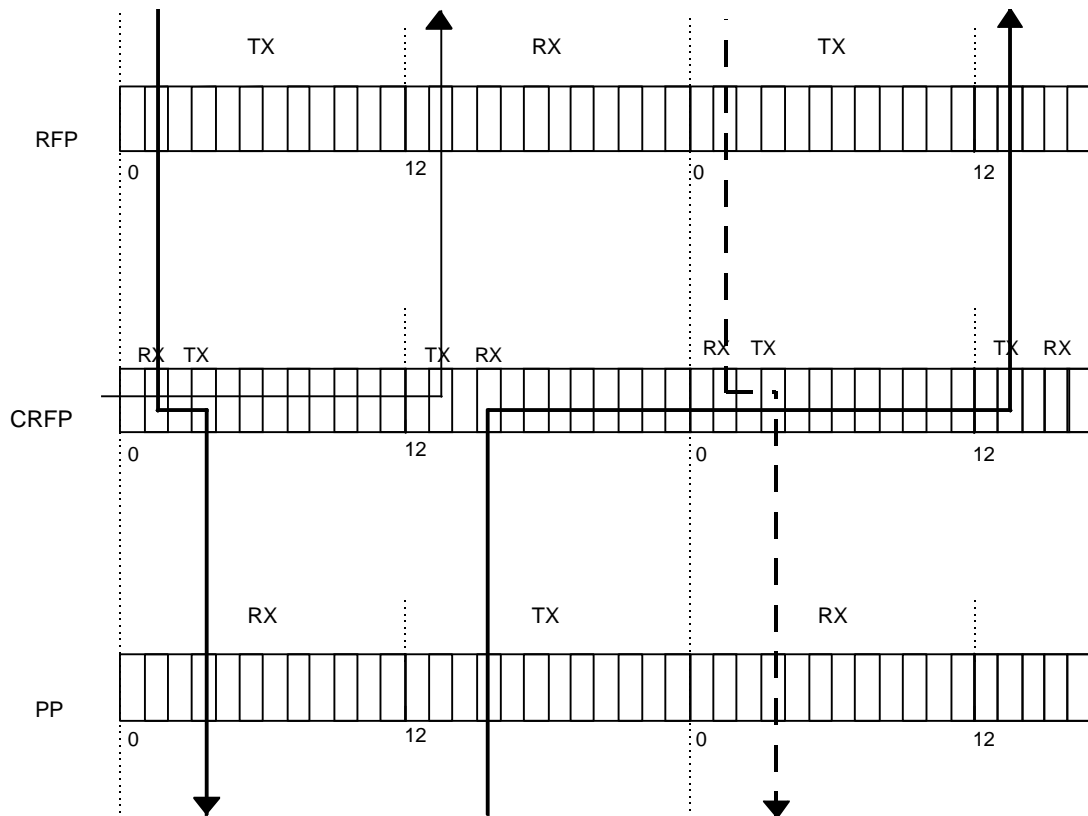

Figure 8: Typical frame multiplexing structure of the CRFP

Use of one hop via a CRFP will cause an additional delay of 1 frame, no matter what timeslots are used.

The frame multiplexing structure supports a combination of both links with PTs and FTs. In this dual frame multiplexing structure the CRFP may transmit or receive during any slot of a frame. A duplex bearer to either the PT or FT is still supported by a combination of a CRFP Receive (RX) and Transmit (TX) slot separated by one half frame.

The CRFP shall support the frame multiplexing structure defined as:

- CRFP-PT frames and CRFP-FT frames are synchronized to the FT frames;
- CRFP-PT and CRFP-FT bearer control complies at least with EN 300 175-3 [5] (e.g. Duplex bearers are separated by one half frame);
- relayed logical channels are buffered to support MAC multiplexing rules of CRFP-PT and CRFP-FT;
- available slots of the CRFP are marked to be either Receive (RX) or Transmit (TX) slots. A slot shall be regarded as TX slot only when it is actually used for transmission.

NOTE 1: During the first half frame (e.g. Slot 0 to 11) all RX slots listen to FT transmissions and all TX slots transmit to PTs. During the second half frame all RX slots listen to PTs and all TX slots should transmit to FT.

- RX and TX slots of one relayed bearer belong to the same half frame.

NOTE 2: In idle mode the CRFP listens to an FT during all frames, transmits at least one dummy bearer (see EN 300 175-3 [5]) to PTs and performs receiver scanning on all other slots. Idle receiver scanning is done in accordance with PT and FT idle receiver scan procedures.

c)- The EUT of REP type shall apply the following frame multiplexing structure.

REP can switch from transmit to receive mode on a time slot base. REP, once locked to a suitable FT (other WRS), is listening for bearer set up attempts on the idle time slots (i.e. slots where REP does not transmit nor receive) of the second half frame while, on the idle time slots of the first half frame, it is scanning for suitable channels and listening for suitable FTs (other WRSs) to get synchronized to. REP shall scan the radio environment in the second half frame synchronously with the locked FT (other WRS).

REP relays the information received from one radio termination to another radio termination, combining Physical and MAC layer functionalities both of a PT and of an FT, with some improvements when interfacing the FT (another WRS). The relay of the information between the two radio terminations is completed within the half frame time interval.

Figure 9 describes an example of frame structure and slot allocation within REP, RFP and PP when relaying one duplex bearer connection through a single hop; figure 10 describes the frame multiplexing structure when relaying one duplex bearer connection through two hops.

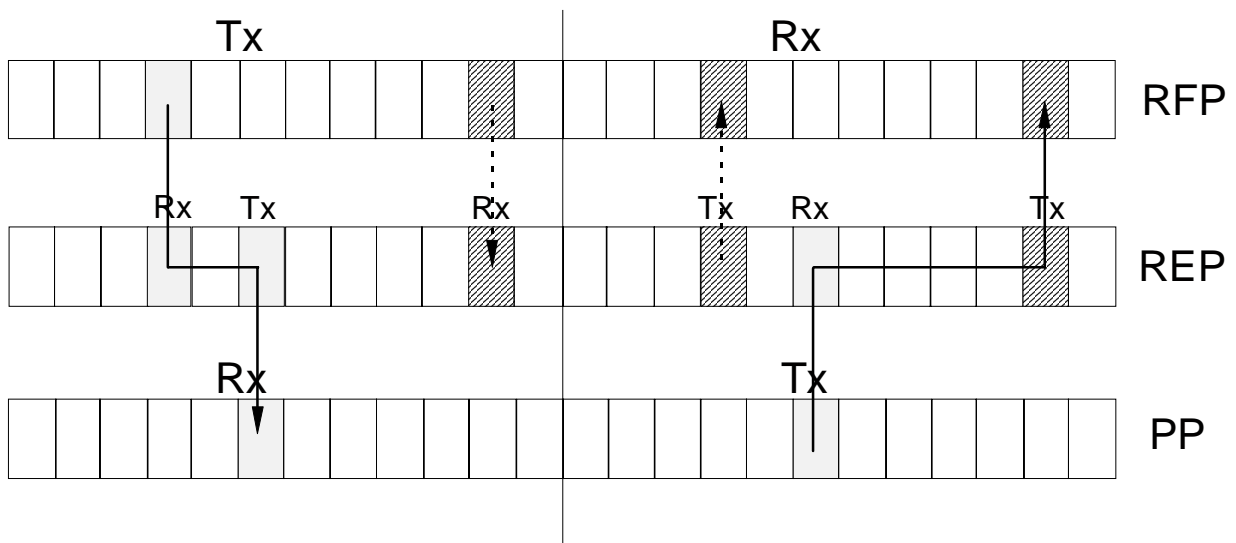

Figure 9: Frame multiplexing structure when relaying one duplex bearer connection through a single hop

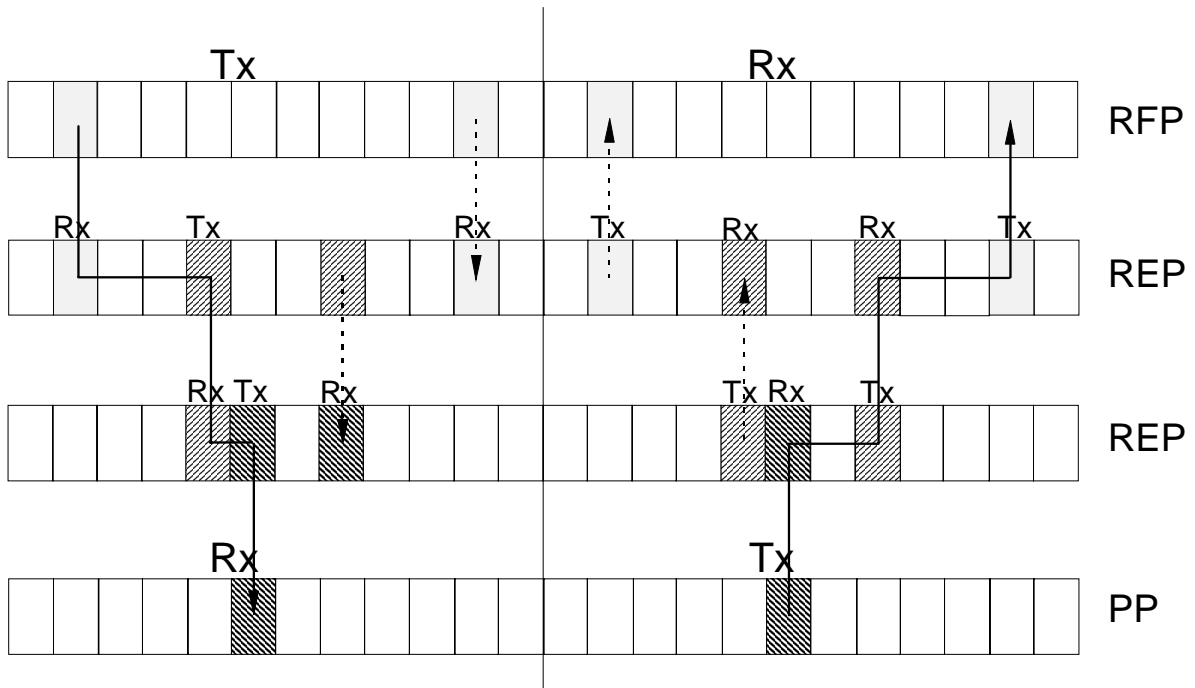

Figure 10: Frame multiplexing structure when relaying one duplex bearer connection through two hops

In figure 11 an example of two single duplex bearer connections, REP relayed with an interlacing procedure (see EN 300 700 [10], clause 6.4.1.1.3) is presented; PP1 and PP2 connections share on REP the slot pair (i.e. the duplex bearer) marked with "S".

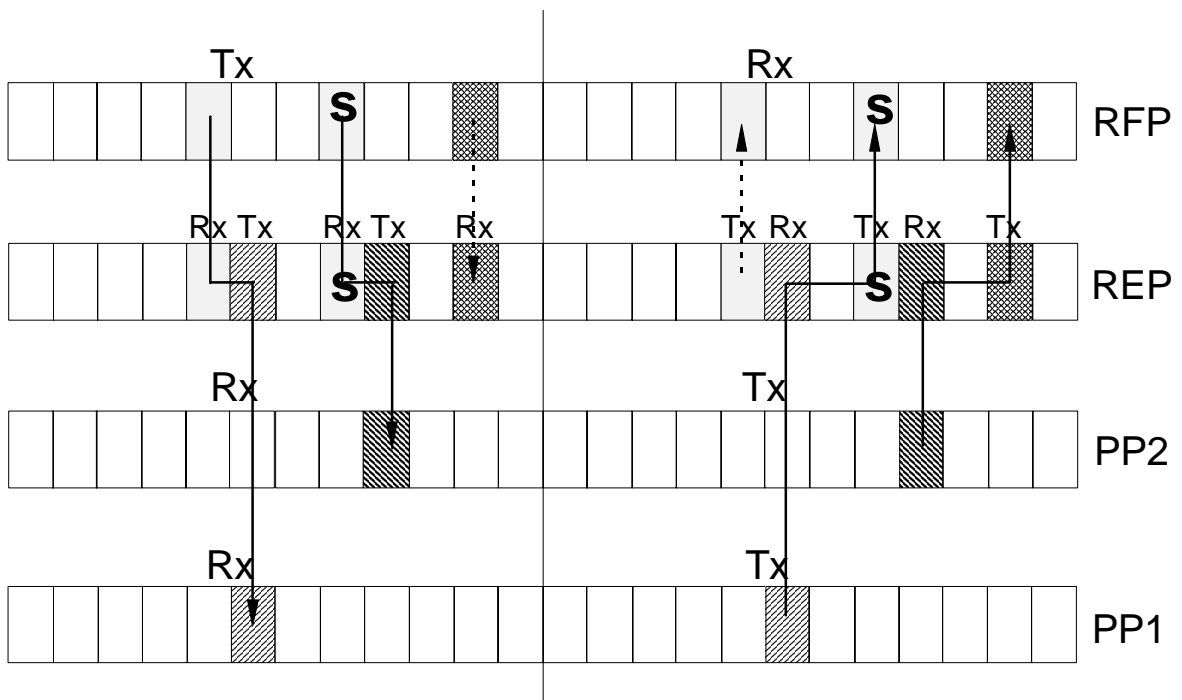

Figure 11: Two single duplex bearer connections, REP relayed with interlacing

d) The REP EUT shall conform to the requirements for channel selection of double duplex bearers.

- Once in one of the states, i.e. Active_Idle or in Active_Traffic or in Active_Locked, REP may start transmission on a physical channel according to EN 300 175-3 [5], clause 11.4 with the following additions:
 - a) double duplex bearers:

The relay of a duplex or of a double duplex bearer requires, at the REP_PT air interface, the setup of a double duplex bearer. Said $((y;y+12);f_y)$ and $((z;z+12);f_z)$ the two time slot pairs of the double duplex bearer to be setup and respectively $((x;x+12);f_x)$ or $((x1;x1+12);f_{x1})$ and $((x2;x2+12);f_{x2})$ the time slot pair or the two time slot pairs of the associated duplex bearer or double duplex bearer to be relayed, the following further restriction has to be respected:

$$0 = < Y < X \quad (\text{where } X = \min (X1;X2)); \text{ and}$$

$$X < Z < = 11 \quad (\text{where } X = \max (X1;X2)).$$

- b) double simplex bearer:

The relay of a double simplex bearer requires, at the REP_PT (REP_FT) air interface, the setup of another double simplex bearer.

Said $(x;x+12)$ the time slot pair of the double simplex bearer to be setup and $(y;y+12)$ the time slot pair of the double simplex bearer to be relayed, the following further restriction has to be respected:

$$X > Y.$$

4.5.12.5 Conformance

Conformance tests as defined in clause 5.3.12 shall be carried out.

4.5.13 Requirements for PPs with direct PP to PP communication mode

4.5.13.1 General requirements

Most PPs will be able to operate also in the normal non-direct communication mode. In this case the direct mode will be temporary, and all PPs in a group of PPs intended to communicate in direct communication mode have to be switched into this mode (manually or by other means), since a PP in non-direct mode can only receive paging information from the system to which it is locked. For further description see EN 300 175-3 [5] annex G.

PPs or CTAs in direct communication mode shall meet the PP requirements for normal non-direct communication with the amendments defined in the present clause.

4.5.13.2 Setting the EUT in direct communications mode

Entering and leaving the direct communications mode shall be made by manual keypad entries or by other means. The EUT shall be set in direct communications mode provided with proper identities. If class E identities are used, the requirements for class E identities in EN 300 175-6 [7], clauses 5.5, 6.1.5 and 6.3.2 shall be met.

When not processing a call, the EUT shall be in active unlocked PP state.
The applicant shall provide information about T1, typically 10 s, and T2 typically 20 s.

4.5.13.3 When the EUT has not initiated a call

When the EUT has not initiated a call, it shall meet the "non-direct mode" PP requirements of the present document, but with the following amendments:

- a) The EUT shall in the active unlocked PP state scan all channels on relevant carriers at least every T1 s.
- b) If ARI class E is used, the paged EUT is allowed to make the bearer setup attempt only on the channel pair where the initiating PP transmits.

4.5.13.4 When the EUT initiates a call

By initiating a call means that the number of the wanted subscriber is entered via the keypad or by other means, and that the EUT at "off-hook command" shall enter the RFP active idle state. See EN 300 175-3 [5], clause 4.3.

When the EUT initiates a call, it shall meet the "non-direct mode" RFP requirements of the present document, but with the following amendments:

- a) the 25 ppm PP timer stability requirements apply. See EN 300 175-2 [4] clause 4.2.2;
- b) An EUT entering RFP mode is allowed to derive over the air frame and slot synchronization from a DECT system having "non-class E" identities;
- c) the EUT shall use FP or PP simplex bearer channel selection rules for the RFP active idle state. See EN 300 175-3 [5], clause 11.4;
- d) the page message shall be transmitted in every multiframe as long as in active idle state;
- e) the short page format shall be used for ARI class E;
- f) the EUT shall revert from active idle RFP state to PP active unlocked state, if a duplex bearer has not been established within $T_2 > T_1$ s;
- g) the PP is not required to do receiver scanning for ARI class E in RFP active idle nor active state. See EN 300 175-3 [5], clause 11.8 and EN 300 175-6 [7], clause 5.5;
- h) if identities class E are used, the N_T message will not contain an ETSI distributed code. See clause 4.5.10.2 of the present document.

4.5.13.5 Conformance

Conformance tests as defined in clause 5.3.13 shall be carried out.

4.5.14 Distributed Communications

4.5.14.1 General requirements

PPs and CTAs with distributed communications option, HyPs, shall be tested as a stand alone PP and shall comply to all relevant PP test cases in the present document. In addition the HyPs shall be tested as an RFP as regards the carrier frequency demands of clause 4.5.2 and reference timer accuracy demands of clause 4.5.3.4 of the present document.

The HyP EUT shall meet the requirements and the applicants declarations as described in the present document.

A HyP requires to be synchronized to a bearer to derive its reference timer for PT and FT transmissions.

4.5.14.2 Testing as a PP

The EUT shall operate as a PP in the test-stand-by mode, TSM, annex C, as a stand alone module.

In this mode it shall be tested as a normal PP. See figure 12.

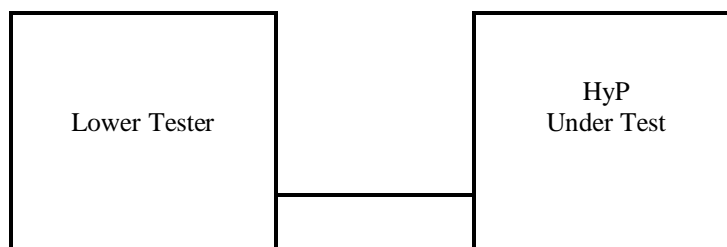

Figure 12: HyP testing as a PP

4.5.14.3 Testing as an RFP

A dummy bearer shall be generated by the Lower Tester or (if that is not possible) by an RFP supplied by the applicant and conforms to the present document. The EUT shall be synchronized to the dummy bearer and shall operate as an RFP in test-stand-by Mode. The dummy bearer may change bearer during the test.

The EUT shall comply with the FT demands of the present document on Reference Timer accuracy, Frequency accuracy, Equipment Identity and Efficient Use of the Radio Spectrum. See figure 13.

NOTE: The power combiner is not needed if the PP and RFP functions have different antenna connectors.

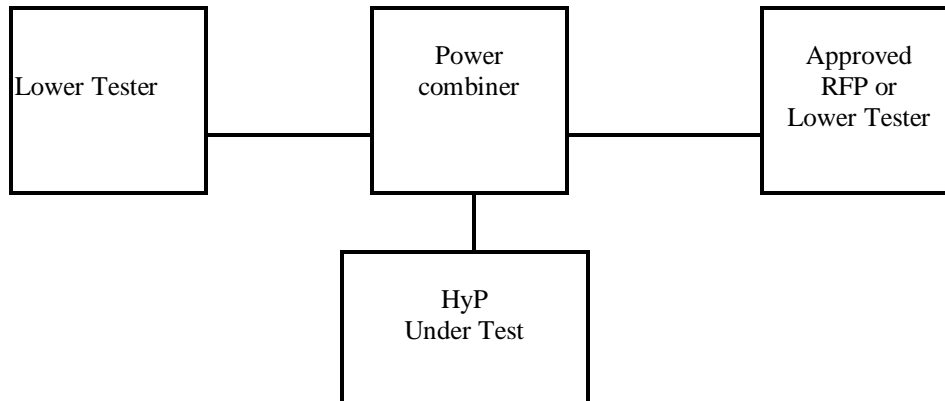

Figure 13: HyP testing as an RFP

4.5.14.4 Conformance

Conformance tests as defined in clause 5.3.14 shall be carried out.

4.5.15 Higher level modulation options

4.5.15.1 Requirements

The 4-level modulation shall be $\pi/4$ -DQPSK and the 8-level modulation $\pi/8$ -D8PSK (see EN 300 175-2 [4] annex D). It is only allowed to use 4-level and/or 8-level modulation in the B + Z or the A + B + Z fields, see EN 300 175-2 [4] clause 4.8 and EN 300 175-3 [5] clause 6.2.1.1, whereby the S + A or the S field respectively shall use the $\pi/2$ -DBPSK 2-level modulation as defined in EN 300 175-2 [4] annex D. The different configurations, 1a to 4b, for allowed combinations of modulation schemes are defined in table 9 below.

Table 9: Configurations of allowed combinations of modulation types in the S-,A and (B+Z)-fields

Configuration	S-field	A-field	(B + Z)-field
1a	GFSK	GFSK	GFSK
1b	$\pi/2$ -DBPSK	$\pi/2$ -DBPSK	$\pi/2$ -DBPSK
2	$\pi/2$ -DBPSK	$\pi/2$ -DBPSK	$\pi/4$ -DQPSK
3	$\pi/2$ -DBPSK	$\pi/2$ -DBPSK	$\pi/8$ -D8PSK
4a	$\pi/2$ -DBPSK	$\pi/4$ -DQPSK	$\pi/4$ -DQPSK
4b	$\pi/2$ -DBPSK	$\pi/8$ -D8PSK	$\pi/8$ -D8PSK

Configuration 1a is the basic DECT modulation scheme for which all tests in the present EN are defined. Equipment that is capable of operating in any of the configurations 2 - 4 shall also be able to operate in configuration 1 (1a or 1b).

Such equipment shall in configuration 1a conform to all requirements of the present document that apply for equipment using the basic 1a configuration.

Such equipment that does not support configuration 1a, shall in configuration 1b conform to all requirements (verdict criteria) of the present document that apply for equipment using the basic 1a configuration, with the exception for clause 4.5.6 "RF carrier modulation" and clauses 4.5.4.1.6 "Minimum power" and 4.5.4.1.7 "Maximum power".

Additionally, if the equipment includes a radio transmitter capable of 4-level and/or 8-level modulation, the requirements of clauses 4.5.5 and 4.5.7 shall apply for the transmissions using the 4-level and/or 8-level modulation in the B + Z or A + B + Z fields.

The applicant shall for RF carrier modulation and power template declare conformance to the standard EN 300 175-2 [4] annex D 4-level and/or 8-level.

4.5.15.2 Conformance

Conformance tests as defined in clause 5.3.15 shall be carried out.

5 Testing for compliance with technical requirements

5.1 General test requirements

5.1.1 Test philosophy

All the tests in the present document are based upon a common philosophy. This philosophy assumes that test equipment is capable of emulating a PT or FT that conforms to the DECT CI specification. Consequently, each test setup consists of the test equipment being connected to the EUT, either by a radio link or via an antenna connector. Figures 14 and 15 show the possible test configurations.

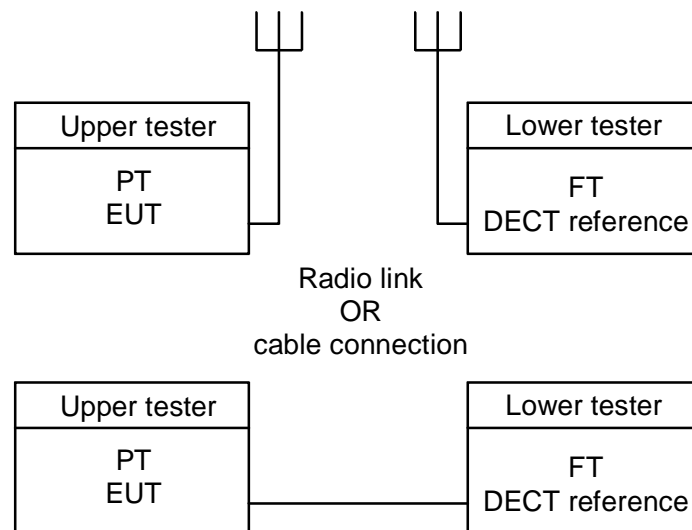

Figure 14: The EUT is a PT

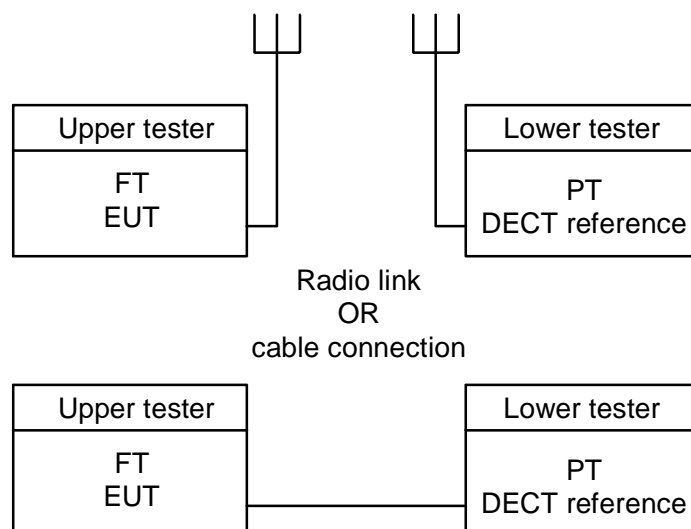

Figure 15: The EUT is an FT

Figures 14 and 15 also show that, if available, the EUT can sometimes be connected to the LT by an antenna connector. This is normally preferred in order to minimize the measurement uncertainties, however, in some test cases this is not permitted and is stated as such in each test case.

The LT shall consist of the general test equipment with the functionality as described in clause 5.1.7. It shall also include an RF interface which can emulate a DECT PT, or FT. The emulated DECT PT and FT (see clause 5.1.9) is an implementation of the DECT CI specification including all the mandatory services and facilities and some provision optional, process mandatory elements as well.

The UT is contained within the EUT and operates in response to test commands which are sent by the LT over the air interface. This enables the LT to place the EUT in a variety of test modes. These are described in clause 5.1.8.

5.1.2 Standard position

The standard position in all test sites, except the stripline arrangement, for equipment which is not intended to be worn on a person, including hand-held equipment, shall be on a non-conducting support, height 1,5 m, capable of rotating about a vertical axis through the equipment. The standard position of the equipment shall be the following:

- a) for equipment with an integral antenna, it shall stand so that the axis of the equipment which in its normal use is closest to the vertical shall be vertical;
- b) for equipment with a rigid external antenna, the antenna shall be vertical;
- c) for equipment with a non-rigid external antenna, the antenna shall be extended vertically upwards by a non-conducting support.

In the stripline arrangement the equipment under test or the substitution antenna is placed in the designated test area in the normal operational position, relative to the applied field, on a pedestal made of a low dielectric material (dielectric constant less than 2).

5.1.3 Test antenna of the LT

When the test site is used for radiation measurements the test antenna shall be used for reception of the field from both the test sample and the substitution antenna. When the test site is used for the measurement of receiver characteristics the antenna shall be used as a transmitting antenna. This antenna shall be mounted on a support capable of allowing the antenna to be used in either a horizontal or vertical polarization and for the height of its centre above the ground to be varied over the specified range. Preferably test antennas with pronounced directivity should be used. The size of the test antenna along the measurement axis shall not exceed 20 % of the measuring distance.

5.1.4 Substitution antenna

The substitution antenna shall be used to replace the equipment under test. For measurements below 1 GHz the substitution antenna shall be a half wavelength dipole resonant at the frequency under consideration, or a shortened dipole, calibrated to the half wavelength dipole. For measurements between 1 GHz and 4 GHz either a half wavelength dipole or a horn radiator may be used.

For measurements above 4 GHz a horn radiator shall be used. The centre of this antenna shall coincide with the reference point of the test sample it has replaced. This reference point shall be the volume centre of the sample when its antenna is mounted inside the cabinet, or the point where an outside antenna is connected to the cabinet.

Above 1 GHz the gain of the substitution antenna shall be relative to an isotropic radiator.

Below 1 GHz where a dipole is used as the substitution antenna no gain correction is needed.

The distance between the lower extremity of the dipole and the ground shall be at least 30 cm.

NOTE: The gain of a horn antenna is generally expressed relative to an isotropic radiator.

5.1.5 Test fixture

5.1.5.1 Description

The test fixture is a radio frequency coupling device associated with an integral antenna equipment for coupling the integral antenna to a 50 Ω radio frequency terminal at the working frequencies of the equipment under test. This allows certain measurements to be performed using the conducted measurement methods. Measurements may only be performed at or near frequencies for which the test fixture has been calibrated.

In addition, the test fixture shall provide:

- 1) a connection to an external power supply; and
- 2) interfaces to other relevant inputs and outputs.

The test fixture should be provided by the applicant.

The performance characteristics of the test fixture shall be approved by the test laboratory and shall conform to the following basic parameters:

- a) the coupling loss shall not be greater than 20 dB;
- b) a coupling loss variation over the frequency range used in the measurement which does not exceed 2 dB;
- c) circuitry associated with the RF coupling shall contain no active or non linear devices;
- d) the Voltage Standing Wave Ratio (VSWR) at the 50 Ω socket shall not be greater than 1,5 over the frequency range of the measurements;
- e) the coupling loss shall be independent of the position of the test fixture and be unaffected by the proximity of surrounding objects or people. The coupling loss shall be reproducible when the equipment under test is removed and replaced;
- f) the coupling loss shall remain substantially constant when the environmental conditions are varied.

The characteristics and calibration shall be included in the test report.

5.1.5.2 Calibration of the test fixture for the measurement of transmitter characteristics

The calibration of the test fixture establishes a relationship between the output of the test fixture and the output of the equipment inside the test fixture. See figure 16 for measuring arrangement for calibration.

The calibration is valid only at a given frequency or range of frequencies and for a given polarization of the reference field.

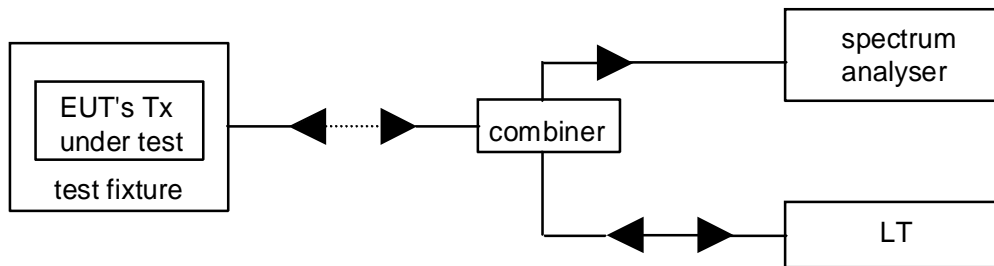

Figure 16: Measuring arrangement for calibration

- a) Using the appropriate method described in clauses 5.3.5.2 and 5.3.5.3 (transmitted power) measure the NTP and note the value of this power and the polarization used.
- b) The transmitter shall be placed in the test fixture which is connected to the spectrum analyzer. The measured level in dBm shall be noted.
- c) The calibration for the test fixture is the linear relationship between the measured power in dBm according to clause 5.3.5 (transmitted power) and the measured power in dBm in this calibration setup.

5.1.5.3 Calibration of the test fixture for the measurement of receiver characteristics

The calibration of the test fixture establishes a relationship between the level of the signal connected to the test fixture and the field strength applied to the equipment inside the test fixture. See figure 17 for measuring arrangement for calibration.

The calibration is valid only at a given frequency and for a given polarization of the reference field.

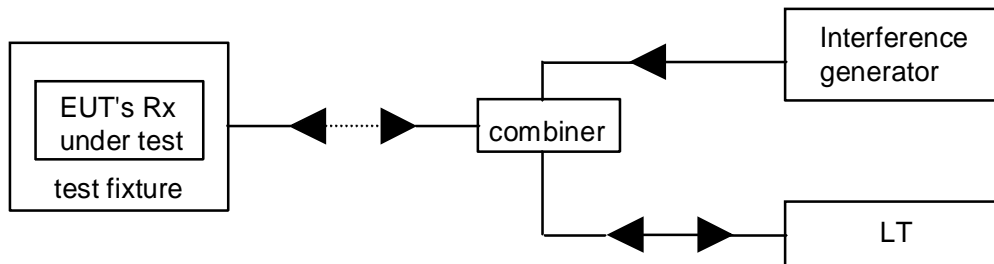

Figure 17: Measuring arrangement for calibration

- a) Measure the sensitivity expressed as field strength for a Bit Error Ratio (BER) of 0,001 or less and note the value of this field strength in dB μ V/m and the polarization used.
- b) The receiver shall be placed in the test fixture which is connected to the LT (with BER measuring test facilities). The level of the signal connected to the test fixture producing the same BER measured according to the method used in step a) shall be noted.
- c) The calibration of the test fixture is thus the linear relationship between field strength in dB μ V/m and the signal generator level in dB μ V emf.

5.1.5.4 Mode of use

A test fixture may be used for tests under extreme temperatures and for transmitter and receiver measurements that can be carried out with an uncalibrated test fixture.

If the calibrated test fixture is used as an alternative for the test site then its use, the characteristics and the calibration shall be recorded in the test report.

5.1.6 Equipment with a temporary or internal permanent antenna connector

5.1.6.1 General

The means to access and/or implement the internal permanent or temporary antenna connector shall be stated by the applicant with the aid of a diagram.

The fact that use has been made of the internal antenna connection to facilitate measurements shall be recorded in the test report.

All references in the present document to antenna connector, external antenna connector and temporary connectors shall be understood to be identical and to mean an external antenna connector and/or temporary and/or internal permanent connector.

5.1.6.2 Equipment with a temporary antenna connector

The applicant, or an authorized representative, may submit one set of equipment with the normal antenna connected, to enable the radiated measurements to be made.

The applicant, or an authorized representative, shall attend the test laboratory at conclusion of the radiated measurements, to disconnect the antenna and fit the temporary connector.

The test laboratory staff shall not connect or disconnect any temporary antenna connector.

Alternatively the applicant, or an authorized representative, may submit two sets of equipment to the test laboratory, one fitted with a temporary antenna connector with the antenna disconnected and the other with the antenna connected.

Each equipment shall be used for the appropriate tests.

5.1.7 Lower Tester (LT)

5.1.7.1 Description

The lower tester is a logical grouping that contains a DECT PT, DECT FT, the measurement equipment and the controller of the DECT testing system. The LT has the job of sending testing commands, performing calculations (e.g. signal processing) and interacting with the EUT for the various tests. The LT may implement the Test Support Profile (TSP) described in annex C in order to support the test messages and procedures in a fully standardized manner. This unit is also involved with DECT RF carrier generation, reception, and demodulation. In addition, the LT has wideband RF requirements for emissions and interference testing. See figure 18 for functional contents of the LT

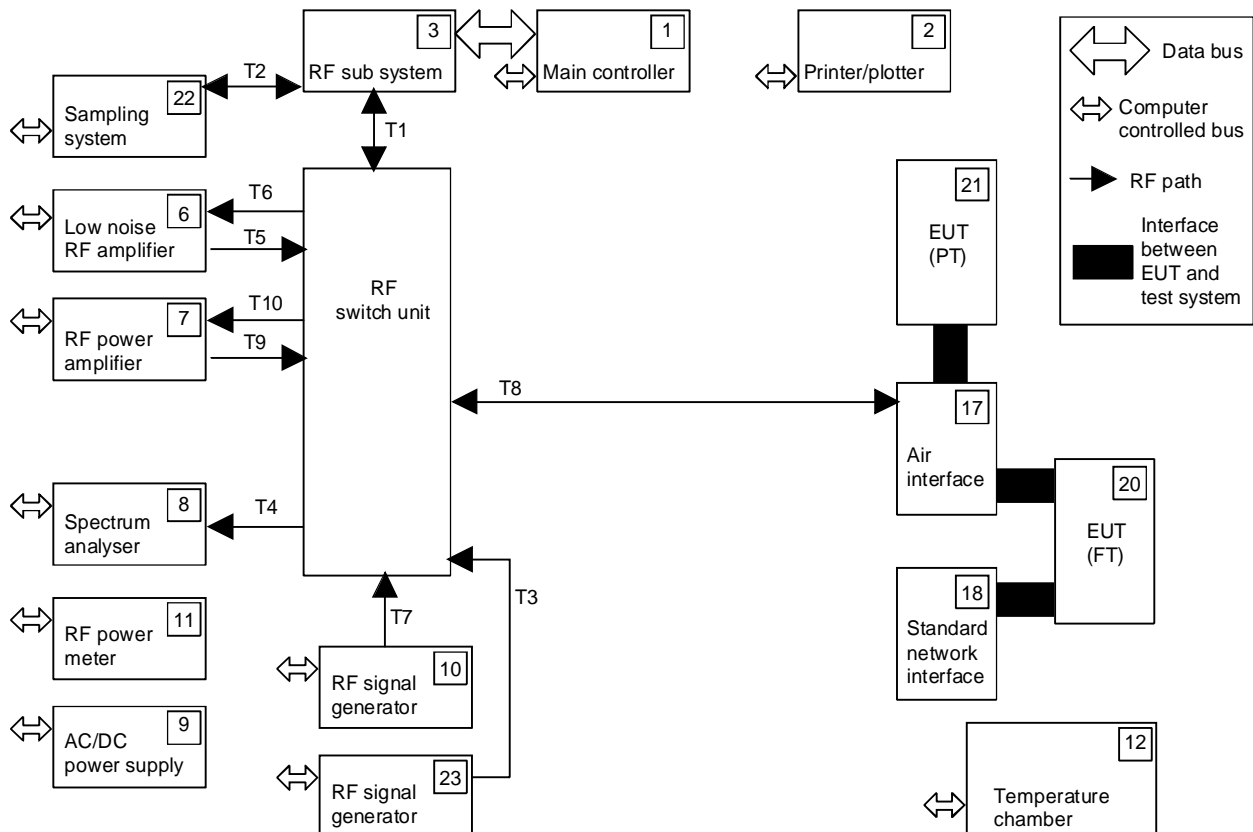

Figure 18: Functional contents of the LT

5.1.7.2 Connections between the EUT and the LT

This is specified in each test case.

5.1.7.3 Functions and abilities

The LT shall include all the functions necessary to perform the tests described in the present document.

These include the ability to:

- generate one actual DECT RF signal;
- generate one Modulated DECT-like carrier;
- generate Continuous Wave (CW) interferer(s);
- sample and store an accurate representation of the EUT's RF signal;
- transmit a variety of test data sequences in the B-field;
- transmit on more than one slot per frame;

- make measurements as described in the present document according to the uncertainties described in clause 5.2;
- emulate a DECT FT, with the possibility to programme all DECT identity codes;
- emulate a DECT PT, with the possibility to programme all DECT identity codes.

5.1.7.4 Signal generation uncertainty

Carrier frequency: ± 5 kHz.

5.1.7.5 Modulated DECT-like carrier

This is a RF carrier using Gaussian shaped frequency-shift keying ($BT = 0,5$) modulated with a 1,152 kbit/s pseudo-random sequence with minimum length 2^9-1 . If the signal is bursted, it is required that the burst is synchronized to the DECT test signal generated by the LT.

5.1.7.6 CW interferers

The uncertainty shall be determined by the overall BER measurement uncertainty of a test case. This is specified in clause 5.2.

5.1.7.7 DECT RF signal

The carrier is defined using the method of clause 4.5.2.3 and it shall meet the requirements needed to fulfill measurement uncertainties of clause 5.2.

During ramp-up the transmitted RF signal shall be the nominal carrier frequency without modulation. The transmitted signal shall comply with the requirements for the transmission burst as given in clause 4.5.4. The NTP - 1 dB shall not be available more than 2 μ s before start of the first transmitted bit. The transmitter attack time as defined in clause 4.5.4.1.4. shall be less than 5 μ s.

The NTP-1 dB of test equipment that cannot provide an unmodulated carrier shall be available within 1 bit period before start of the first bit transmitted. Moreover the transmitter attack time as defined in clause 4.5.4.1.4 needs to be less than a 2 bit period.

5.1.7.8 Test modulation signals

The test modulating signal is a baseband signal which modulates a carrier and is dependent upon the type of equipment under test and also the measurement to be performed.

Signals for data (bit stream):

- D-M2:** A signal representing a pseudo-random bit sequence of at least 511 bits in accordance with ITU-T Recommendation O.153 [11]. This sequence shall be continuously repeated. This signal shall be used as a wanted signal.

5.1.8 Upper Tester (UT)

5.1.8.1 Description of the UT

The UT is part of, but not necessarily restricted to, the EUT. For the purpose of testing, an EUT capable of transmitting shall recognize a mandatory set of test commands sent by the LT. The ability to recognize and implement these commands is contained in the UT which is resident in the medium access control layer as described in EN 300 175-3 [5] clause 12, and as refined by clause 4.5.12. All DECT equipment shall be capable of recognizing these commands. An EUT which is declared as implementing the TSP shall implement the provisions of the TSP described in annex C. The implementation of the TSP is not mandatory.

5.1.8.2 The test standby mode

Accessibility to these messages is controlled by some means of mechanical interlocking method or manual switching (e.g. dip-switch, jumper, prom, or key-pad code as designated by the applicant) to prevent accidental execution of these messages in a DECT user environment.

When the EUT has been switched into a mode whereby the test messages are accessible, the EUT is said to be in the test standby mode.

5.1.8.3 Test messages

The MAC layer test messages provide the following functions:

- a) instruct the EUT to transmit on a LT-specified physical channel. The test message also determines whether the handover function of the EUT (if so equipped) is disabled and if previous bearers are to be maintained (see EN 300 175-3 [5], clauses 7.2.5.4.2 and 12.3);
- b) instruct the EUT to perform the loopback function in which a test data pattern transmitted by the LT is replicated in the reply transmission of the EUT. The test data pattern is a bit sequence located in the D-fields of the LT and EUT. The bits of the D-field that are affected by the loopback function depend on the equipment type and are defined in table 10.

Table 10: Loopback

Equipment type	Loopback Bits
Transmits only A-field	a_{16} to a_{47}
Transmits half-slots	b_0 to b_{79}
Transmits full-slots	b_0 to b_{319}
Transmits double-slots	b_0 to b_{799}

Equipment capable of transmitting more than one slot type shall use the longest slot type for this test message (see EN 300 175-3 [5], clauses 7.2.5.4.3 and 12.4);

- c) defeat antenna diversity and select the specified antenna for operation in those EUTs possessing antenna diversity (see EN 300 175-3 [5], clauses 7.2.5.4.4 and 12.5);
- d) initiate the bearer handover procedure resident in an EUT that is declared by the applicant as possessing bearer handover capability (see EN 300 175-3 [5], clauses 7.2.5.4.5 and 12.6);
- e) permit inclusion of proprietary test messages by means of the "escape" code (see EN 300 175-3 [5], clauses 7.2.5.4.6 and 12.8);
- f) pass test messages (when applicable) to the network layer of the EUT (see EN 300 175-3 [5], clauses 7.2.5.4.7 and 12.7);
- g) provide for a means to reset the test state of the EUT by means of the "clear test modes" message (see EN 300 175-3 [5], clauses 7.2.5.4.8 and 12.9).

5.1.8.4 Dummy setting when EUT is a RFP and it is in test stand-by mode

If the EUT is a RFP, the dummy bearer shall either be switched off when the traffic bearer is active in test stand-by mode, or it is placed on the same RF carrier as the traffic bearer. If necessary, the Applicant shall supply a method to do this.

Such a method may be controlled either by some means of manual switching (e.g. dip-switch, jumper, prom, or key-pad code as designated by the applicant), or by means of a proprietary "escape" code test message.

5.1.9 Description of the lower tester FT and PT

The lower tester FT and PT are systems consisting of the RF equipment, controller(s), software, and other related components necessary to be capable of implementing all the functions defined in the DECT specification documents.

5.1.10 General test methods

5.1.10.1 General

It is recognized that for some parameters alternative test methods may exist. It is the responsibility of the test laboratory to ensure that any alternative test method used yields results identical to those described in the present document.

5.1.10.2 Sampling the RF signal

5.1.10.2.1 Introduction

A number of tests in the present document require the RF signal to be sampled and demodulated. The following text describes the sampling method that should be performed in the LT.

5.1.10.2.2 Sampling method

The equipment under test shall be connected to the LT. This connection shall be direct for an EUT having an antenna connector or via an antenna coupling device for an EUT with an integral antenna and not having means of connecting an external antenna, unless otherwise specified in the present document.

Handover (if available) shall be disabled in the EUT while the sampling takes place (see clause 5.1.8.3 for the appropriate test message reference).

Antenna diversity (if available) shall be disabled in the EUT while the sampling takes place (see clause 5.1.8.3 for the appropriate test message reference).

Using a sampling measurement method, capture a representation of the EUT's transmitted RF signal. The position in a physical packet shall be calculated using the samples from the physical packet, knowing the received bit pattern. These calculated bit positions shall be used as the time reference when making measurements of RF frequency, phase and power.

NOTE: When reference is made to p_0 in the present document, for example, it is intended that its position is calculated using many samples of a physical packet. The frequency, power or phase at this theoretical position of p_0 can then be measured.

5.1.10.3 Determining the reference position

During many tests the EUT is required to be oriented specifically in relation to the test antenna connected to the LT.

This position is called the reference position and is defined in the following clauses.

5.1.10.3.1 Case 1: EUTs that cannot transmit

If the EUT has only an integral antenna then the applicant shall inform the test laboratory of the orientation of the integral antenna.

5.1.10.3.2 Case 2: EUTs that can transmit

The EUT shall be placed in a mode whereby it is transmitting.

NOTE: For most tests the EUT will have already been placed in a transmission mode.

The EUT shall be rotated in both horizontal and vertical planes in order to locate the direction of maximum field strength that is detected by the test antenna. This orientation shall be called the reference position.

5.1.10.4 Bit error rate (BER) and Frame Error Ratio (FER) measurements

BER measurements are carried out by comparing data in the loop back field transmitted by the LT with data in the loop back field received from the EUT (which is in loop back mode).

If the EUT does not recognize the sync word of the frame transmitted by the LT and therefore is unable to loop back any data, this frame shall be disregarded from the BER measurement.

Refer to annexes D and E for further information and for the definition of FER.

5.1.11 Test setup

5.1.11.1 General

Test setups have been defined according to ISO/IEC 9646-1 [8]. The test cases listed in table 3 have an associated test setup.

The numbers inside the figures shown in clauses 5.1.11.1 to 5.1.11.5 refer to functional blocks inside the LT. These are shown in figure 18 in clause 5.1.7.1.

5.1.11.2 Test setup 1

For the test setup depicted in figure 19, the following test cases apply.

Test Case: 1, 2, 3, 4, 5, 6, 7, 8, 13, and 14.

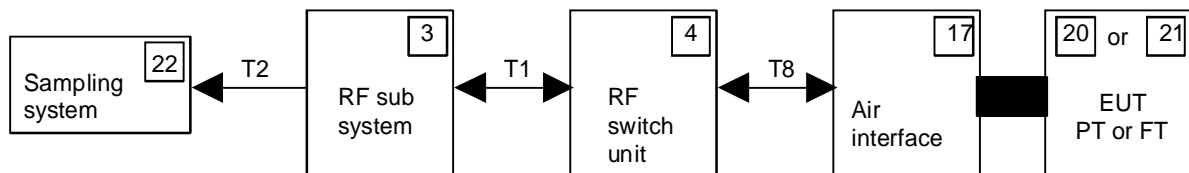

Figure 19: Test setup 1

5.1.11.3 Test setup 2

For the test setup depicted in figure 20, the following test cases apply:

Test Case: 15 and 17.

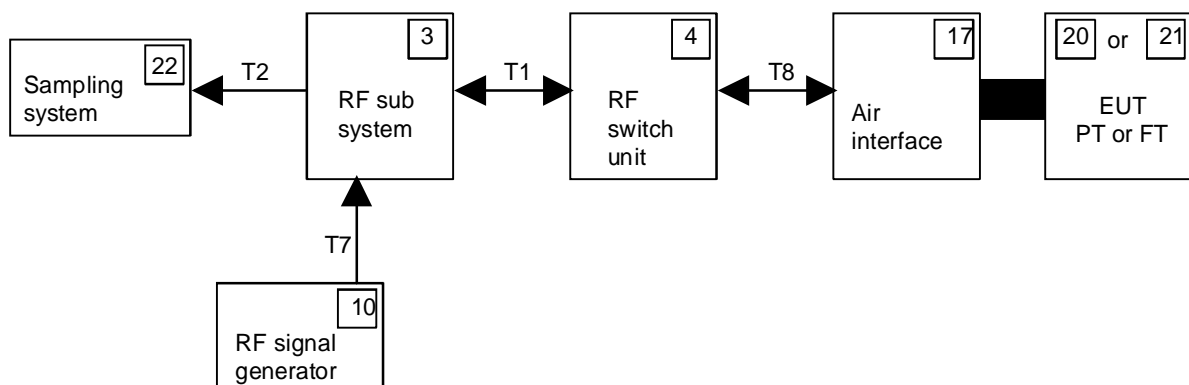

Figure 20: Test setup 2

5.1.11.4 Test setup 3

For the test setup depicted in figure 21, the following test case applies:

Test Case: 18.

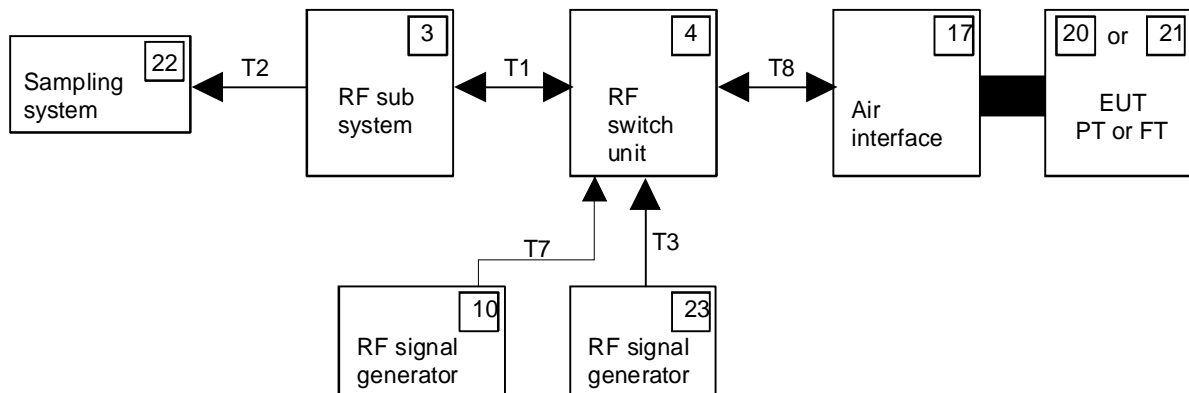

Figure 21: Test setup 3

5.1.11.5 Test setup 4

For the test setup depicted in figure 22, the following test cases apply:

Test Case: 9, 10, 11, 12, and 19.

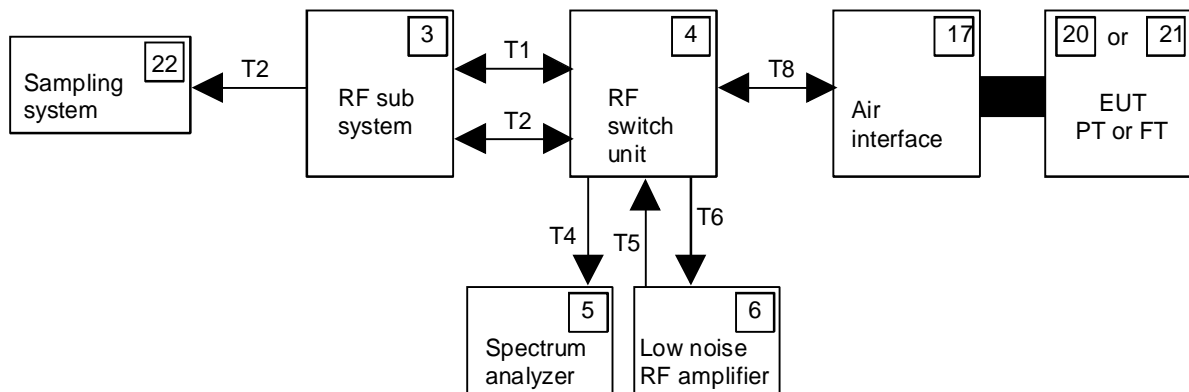

Figure 22: Test setup 4

5.1.11.6 Test setup 5

For the test setup depicted in figure 18, the following test case applies:

Test Case: 23.

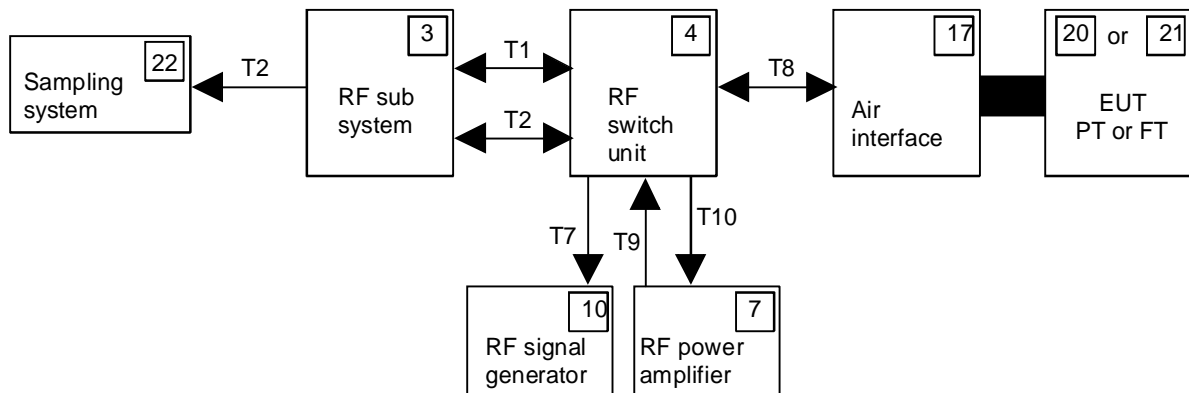

Figure 23: Test setup 5

5.1.12 Test arrangements for intermodulation measurements

5.1.12.1 PT to PT arrangement

In the PT to PT situation, the minimum distance for non-interference operation is specified as being 0,5 meters. Figure 24 shows the testing arrangement:

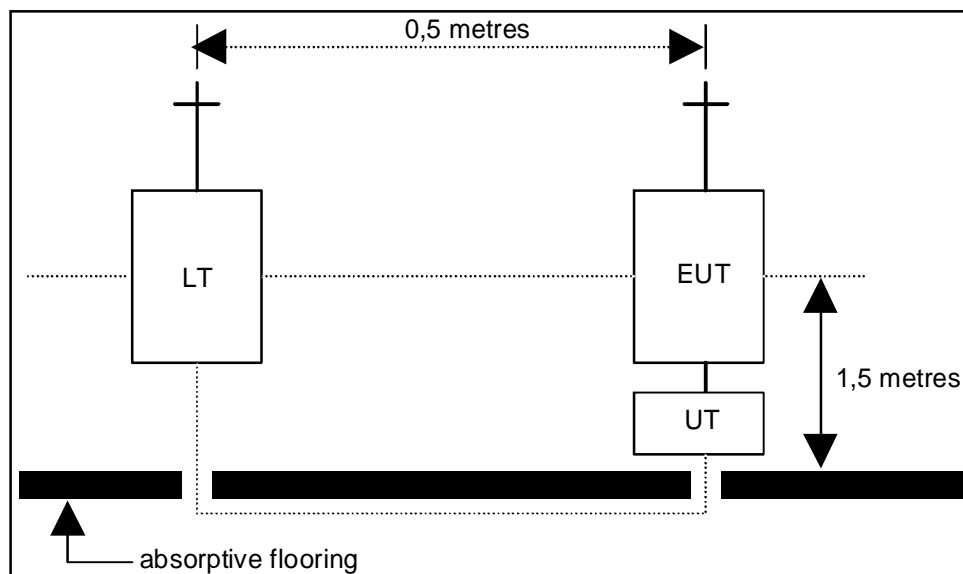

Figure 24: Testing arrangement

The elevation of the antennas are the same. Absorptive flooring is used to minimize reflection effects. The link between the UT and the EUT indicates the control of the EUT via the DECT air interface.

5.1.12.2 FT to FT arrangement

In the FT to FT situation, the minimum distance for non-interference operation is specified as being 1 m. Figure 25 shows the testing arrangement.

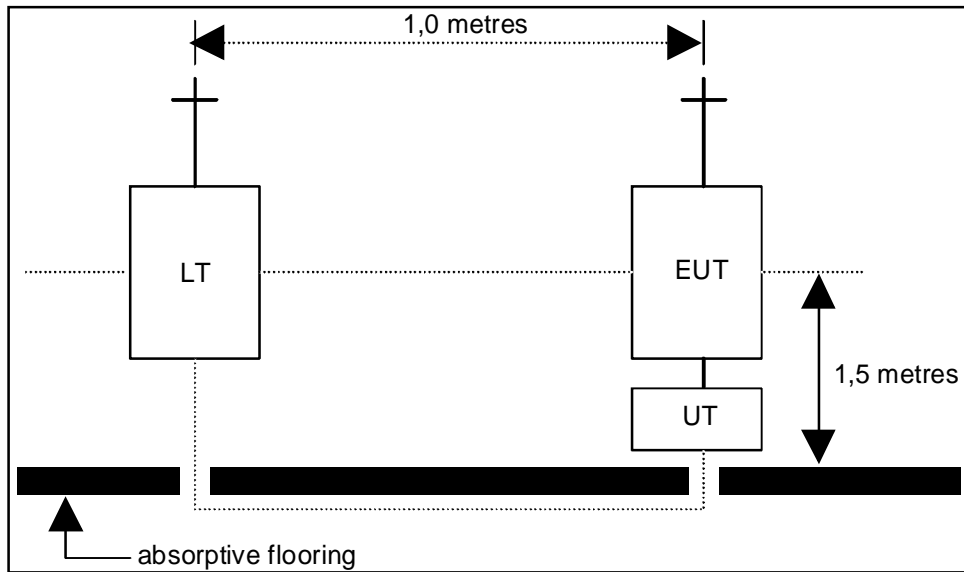

Figure 25: Testing arrangement

The elevation of the antennas are the same. Absorptive flooring is used to minimize reflection effects. The link between the UT and the EUT indicates the control of the EUT via the DECT air interface.

5.1.12.3 FT to PT arrangement

In the FT to PT situation, the minimum distance for non-interference operation is specified as being 1 m. Figure 26 shows the testing arrangement.

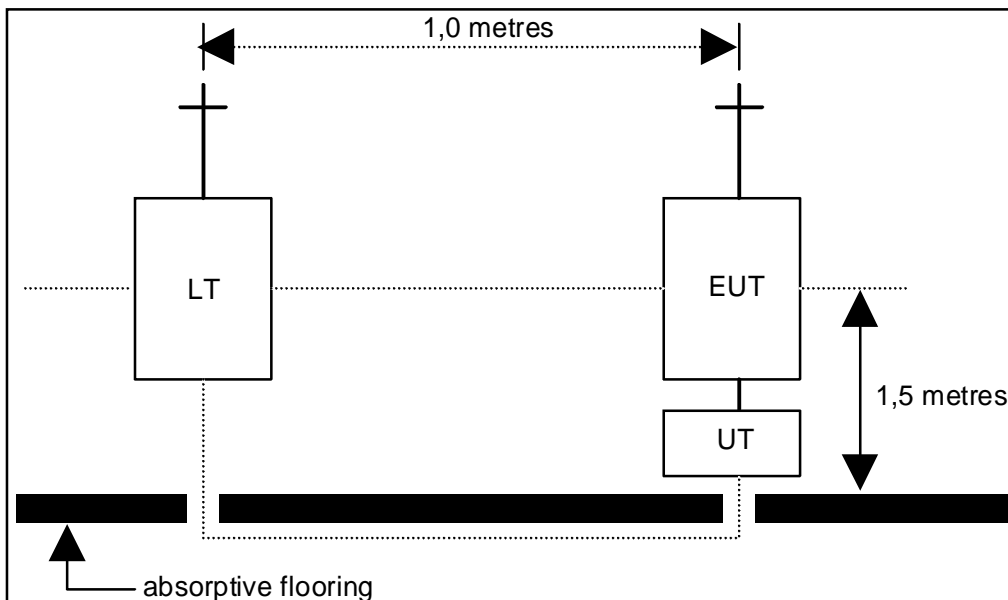

Figure 26: Testing arrangement

The elevation of the antennas are the same. Absorptive flooring is used to minimize reflection effects. The link between the UT and the EUT indicates the control of the EUT via the DECT air interface.

5.1.13 Test conditions, power supply and ambient temperatures

5.1.13.1 General

The following conditions shall apply during all tests:

- atmospheric pressure: 86 to 106 kPa;
- Relative Humidity (RH): 5 % to 75 % non-condensing;

The temperature conditions and voltage supply applied in each test are specified as either nominal or extreme. The definitions of nominal and extreme are contained in clauses 5.1.13.2 and 5.1.13.3. Each test case defines whether nominal or extreme conditions apply. In some test cases only extreme temperature conditions apply and this is stated in the appropriate test case.

Before measurements are made, the equipment shall have reached thermal equilibrium in the test chamber. The equipment shall be switched off during the temperature stabilizing period. If the thermal equilibrium is not checked by measurements, a temperature stabilizing period of at least one hour, or such period as may be decided by the test laboratory, shall be allowed.

Before the start of a test, but after reaching thermal equilibrium in the test chamber, the equipment shall be powered up. For RFPs, the time between power-up and the start of testing shall be greater than 15 minutes. For PPs, testing may commence any time after 1 minute after power-up.

The sequence of measurements shall be chosen, and the humidity content in the test chamber shall be controlled, so that condensation does not occur.

It is not necessary to control the atmospheric pressure during testing.

When it is impractical to carry out the tests under these conditions, a statement giving the actual temperature and relative humidity during the tests shall be recorded in the test report.

5.1.13.2 Nominal test conditions

These are identical for all types and classes of equipment. This is clarified by figures 27, 28 and 29.

PP:

	VOLTAGE		
	MIN	NOM	MAX
0°			
+15° to +35°			
+40°			

Figure 27: Nominal test condition for PPs

FP, RFP, CCFP for Class E1 use:

	VOLTAGE		
	MIN	NOM	MAX
+10°			
+15° to +35°			
+40°			

Figure 28: Nominal test condition for Class E1

FP, RFP, CCFP for Class E2 use:

	VOLTAGE		
	MIN	NOM	MAX
-10°			
+15° to +35°		■	
+55°			

Figure 29: Nominal test condition for Class E2

For nominal temperature, each measurement is made at the temperature of the test site, which shall be within +15 °C to +35 °C.

5.1.13.3 Extreme test conditions

The extreme test conditions are determined by the type of equipment under test. Figures 30, 31 and 32 class the EUT as either PP, FP, RFP or CCFP (see clause 3.2 for definitions).

In addition, FPs, RFPs and CCFPs shall be classed as either for Class E1 use or Class E2 use. Class E1 use refers to indoor areas allowing for personal comfort, for example, homes, offices, laboratories or workshops. Class E2 use refers to all other areas.

For the extreme temperature ranges of -10 °C, 0 °C, +10 °C and +40 °C, measurements shall be made at the specified temperature with a tolerance of ± 1 °C.

The definitions of minimum, nominal and maximum applied voltage are contained in clauses 5.1.13.5 and 5.1.13.6.

PP:

	VOLTAGE		
	MIN	NOM	MAX
0°	■		■
+15° to +35°		■	
+40°	■		■

Figure 30: Extreme test condition for PPs

FP, RFP, CCFP for Class E1 use:

	VOLTAGE		
	MIN	NOM	MAX
+10°	■		■
+15° to +35°		■	
+40°	■		■

Figure 31: Extreme test condition for Class E1

FP, RFP, CCFP for Class E2 use:

	VOLTAGE		
	MIN	NOM	MAX
-10°	■		■
+15° to +35°		■	
+55°	■		■

Figure 32: Extreme test condition for Class E2

5.1.13.4 Test power source - general requirements

During the execution of the essential test suites, the power source of the equipment shall be replaced by a test power source, capable of producing normal and extreme test voltages as specified in clauses 5.1.13.5 and 5.1.13.6. The internal impedance of the test power source shall be low enough for its effect on the test results to be negligible. For the test purposes, the voltage of the power source shall be measured at the input terminals of the equipment.

If the equipment is provided with a permanently connected power cable, the test voltage shall be measured at the point of connection of the power cable to the equipment.

In equipment with incorporated batteries, the test power source shall be applied as close to the battery terminals as is practical. In each case connections shall be made readily available by the applicant.

During tests, the power source voltages shall be maintained within a tolerance of ± 3 % relative to the voltage at the beginning of each test.

5.1.13.5 Nominal test power source

5.1.13.5.1 Mains voltage

The normal test voltage for equipment to be connected to the mains shall be the nominal mains voltage. For the purpose of the present document, the nominal voltage shall be the voltage or voltages for which the equipment was designed as declared by the applicant. The frequency of the test power source corresponding to the ac mains shall be between 49 Hz and 51 Hz.

5.1.13.5.2 Regulated lead acid battery power sources

When the radio equipment is intended for operation from a lead-acid chemistry battery source, the source voltage used during testing shall be 1,1 times the nominal voltage of the battery (i.e. $1,1 \times \text{number of cells} \times 2 \text{ V/cell}$).

5.1.13.5.3 Nickel cadmium battery

When the equipment is intended for operation from a nickel-cadmium chemistry battery source, the source voltage used during testing shall be the nominal voltage of the battery ($1,2 \text{ V/cell}$).

5.1.13.5.4 Other power sources

For operation from other power sources or types of battery, either primary or secondary, the normal test source voltage shall be that declared by the applicant.

5.1.13.6 Extreme test power source

5.1.13.6.1 Mains voltage

The extreme test source voltages for equipment to be connected to an ac mains source shall be the nominal mains voltage ± 10 %. The frequency of the test power source shall be between 49 Hz and 51 Hz.

5.1.13.6.2 Regulated lead acid battery power sources

When the equipment is intended for operation from the usual type of regulated lead acid battery source, the extreme test voltages shall be 1,3 and 0,9 times the nominal voltage of the battery.

5.1.13.6.3 Nickel cadmium battery

When the equipment is intended for operation from the usual type of nickel cadmium battery, the extreme test voltages shall be 1,25 and 0,9 times the nominal voltage of the battery.

5.1.13.6.4 Other power sources

The lower extreme test voltage for equipment with power sources using primary batteries shall be as follows:

- a) for Leclanché type of battery: 0,85 times the nominal voltage;
- b) for other types of primary battery: the end point voltage declared by the applicant.

The upper extreme test voltage shall be the nominal voltage of the battery.

For equipment using other power sources, or capable of being operated from a variety of power sources, or designed for operation within extreme voltage limits not in accordance with those quoted above the extreme test voltages shall be those agreed between the applicant and the test laboratory and shall be recorded with the test results.

5.1.13.7 Testing of host connected equipment and plug-in cards

5.1.13.7.1 Permitted approaches

For equipment for which connection to or integration with host equipment is required to offer functionality, two alternative approaches are permitted. The applicant shall declare which alternative shall be used.

5.1.13.7.2 Alternative A: composite equipment

A combination of a DECT radio equipment part and a specific type of host equipment may be used for testing according to the present document.

Where more than one such a combination is intended, each combination shall be tested separately.

In case a specific combination of host and DECT radio equipment part is tested as a composite system for type approval, it is expected that testing shall not be repeated for those other combinations of hosts and DECT radio equipment parts which are based on substantially similar host models on the condition that the variations in mechanical and electrical properties between such host models are unlikely to have any significantly different influence on the radio characteristics of the DECT radio equipment part and providing that the radio module cannot be used without electrical, mechanical or software modifications in variations of hosts different from those represented by the units used for the type examination.

5.1.13.7.3 Alternative B: use of a test jig and three hosts

Where the DECT radio equipment part is intended for use with a variety of host systems, the applicant shall supply a suitable test jig. The test jig shall be designed such that alteration of the DECT radio equipment's intrinsic emissions is minimized. Where connection between the DECT radio equipment part and the host is by means of cables, optical fibers or similar means between control and/or power ports, the connection to the host shall be considered a suitable test jig.

The test jig shall allow the DECT radio equipment part to be powered and stimulated in a way similar to the way it would be powered and stimulated when connected to or inserted into host equipment.

In addition to tests on the test jig, the DECT radio equipment part shall be tested according to clauses 5.3.5.2, 5.3.7.2, 5.3.7.5.2 and 5.3.8.7 if the equipment is provided with an integral antenna, or clauses 5.3.5.3, 5.3.7.2, 5.3.7.5.3 and 5.3.8.7 if the equipment is provided with an antenna connector; when connected to or inserted into three different hosts. These hosts shall be provided by the applicant and shall be selected from the list of compatible hosts as published by the applicant as part of the user documentation supplied with the radio equipment part. The selection of hosts shall be agreed to by the applicable authority.

For those tests required by the previous clause, with the DECT radio equipment part to be connected to or inserted in host equipment, the combination shall be tested against the requirements except for cabinet radiation from the enclosure which only in these specific tests shall be measured according to the requirements that apply to the host equipment. When the host equipment is Information Technology Equipment (ITE), the requirements of EN 55022 [12], class B apply.

5.2 Interpretation of the measurement results

The interpretation of the results recorded in a test report for the measurements described in the present document shall be as follows:

- the measured value related to the corresponding limit will be used to decide whether an equipment meets the requirements of the present document. Allowance for uncertainty of the measurement shall only be given if this is permitted by the corresponding clause on verdict criteria;
- the actual value of the measurement uncertainty for the measurement of each parameter shall be included in the test report;
- the recorded value of the actual measurement uncertainty shall be, for each measurement, equal to or lower than the figures in table 11.

For the test methods, according to the present document, the measurement uncertainty figures shall be calculated in accordance with ETR 028 [13] and shall correspond to an expansion factor (coverage factor) $k = 1,96$ or $k = 2$ (which provide confidence levels of respectively 95 % and 95,45 % in the case where the distributions characterizing the actual measurement uncertainties are normal (Gaussian)).

Table 11 is based on such expansion factors.

Table 11: Maximum measurement uncertainty

Parameter	Uncertainty
Relative drift radio frequency	± 2 kHz
Absolute radio frequency:	± 10 kHz
Conducted emissions:	± 1 dB
Radiated emissions:	± 3 dB
Absolute RF power (via an antenna connector):	± 1 dB
Absolute RF power (for unwanted emissions in the DECT band):	± 4 dB
Absolute RF power (for unwanted emissions outside the DECT band):	conducted: ± 4 dB radiated: ± 6 dB
Relative RF power:	± 1 dB
Absolute RF power (radiated):	± 3 dB
Relative Packet timing:	$\pm 0,1$ μ s
Absolute Packet timing:	± 1 μ s
Timing stability of FT:	1 ppm
Transmitter burst transient time:	± 20 % (of the measured value)
Peak frequency deviation:	± 10 kHz

5.3 Essential radio test suites

5.3.1 General

An EUT will operate on a specific subset of all potential carriers (see clause 4.5.2.1). This subset constitutes a frequency band with a lower band edge F_L MHz and an upper band edge F_U MHz. Various tests under this clause 5.3 are defined for carriers $c = 0, 1, \dots, 9$ as a reference band. In those tests carrier $c=0$ shall generally be exchanged to "the carrier closest to F_U ", carrier $c = 9$ shall generally be exchanged to "the carrier closest to F_L " and carrier $c = 5$ shall generally be exchanged to "one carrier inside the band".

This applies as well, were relevant, to references made to EN 300 175-2 [4] and EN 300 175-3 [5].

5.3.2 Accuracy and stability of RF carriers

5.3.2.1 Test environment

The test shall take place at a test site or in a test fixture.

If the EUT has an antenna connector then it shall be used to connect the EUT to the LT.

The test shall take place under extreme test conditions.

5.3.2.2 Method of measurement

- a) The LT shall place the EUT in a mode whereby the EUT is positioned in a LT specified slot and RF channel $c = 5$. If so equipped, the handover function in the EUT shall be disabled (see clause 5.1.8.3 for the appropriate test message reference).
- b) The EUT shall be placed in a test mode whereby it performs the loopback function as referenced in clause 5.1.10.3.
- c) The LT shall transmit a packet with a test sequence in the loopback field of the packet. This test sequence shall be such that the sequence 0000 1111 0000 1111 is transmitted at the antenna of the EUT in the loopback field of the reply packet.
- d) Using the sampling method described in clause 5.1.10.2.2, capture a representation of the EUT's transmitted RF signal after allowing the EUT to be in an active-locked state (see EN 300 175-3 [5] clause 4.3.1) for more than 1 s.
- e) The EUT's carrier frequency for d) shall be assumed to be the average of the measured absolute frequencies of the loopback bits.
- f) Steps c) to e) shall be repeated until the appropriate number of measurements as shown in table 12 have been made.

Table 12: Measurement repetition

Equipment type	Number of measurements
A-field only transmit	100
Half-slot transmit	40
Full-slot transmit	10
Double-slot transmit	5

The centre frequency of the EUT is taken to be the mean value of the measurements.

- g) Steps c) to f) shall be repeated for all combinations of temperatures and power supply voltages allowed under extreme test conditions.
- h) Steps c) to g) shall be repeated for RF channels $c = 0$ and 9.
- i) When the EUT is a PP, then c) to h) shall be repeated, with the addition that the RF signal is sampled (in d)) during the first 1 s of the EUT going into a transmit mode from a non-transmitting mode. If necessary a) and b) may be repeated as required in order to make the number of measurements specified in f).

5.3.2.3 Verdict criteria when the EUT is a RFP

The carrier frequencies as measured shall be within ± 50 kHz of the appropriate nominal DECT carrier frequency F_c .

The results obtained shall be compared to the limits in clause 4.5.2.2 in order to prove compliance with the requirement.

5.3.2.3a Verdict criteria when the EUT is a PP

Case 1: When the measurement is made during the first 1 s of the EUT going into a transmit mode from a non-transmitting mode:

The carrier frequencies as measured either relative to an absolute frequency reference or relative to the received carrier, shall be within ± 100 kHz of the nominal DECT carrier frequency F_c .

The results obtained shall be compared to the limits in clause 4.5.2.2 in order to prove compliance with the requirement.

Case 2: When the measurement is made at any other time:

The carrier frequencies as measured either relative to an absolute frequency reference or relative to the received carrier, shall be within ± 50 kHz of the nominal DECT carrier frequency F_c .

The results obtained shall be compared to the limits in clause 4.5.2.2 in order to prove compliance with the requirement.

5.3.3 Accuracy and stability of timing parameters

5.3.3.1 Measurement of packet timing jitter

5.3.3.1.1 Test environment

The test shall take place at a test site in a test fixture. If the EUT is equipped with a temporary connector, the temporary connector may be used in place of the test fixture for this test.

If the EUT has an antenna connector then it shall be used to connect the EUT to the LT.

The test shall take place under extreme test conditions.

5.3.3.1.2 Method of measurement

- The LT shall place the EUT in a mode whereby the EUT is positioned in a LT specified slot and frequency. If so equipped, the handover function in the EUT shall be disabled (see clause 5.1.8.3 for the appropriate test message reference).

The applicant shall declare to the testing laboratory the time required for system synchronization by the EUT.

- Using a sampling method, capture a representation of the RF signal transmitted by the EUT on the same slot position in 2 consecutive frames.
- The LT shall determine the positions of p0 in the slots that were sampled in step b) above. See figure 33.
- Steps b) and c) shall be repeated 1 000 times.
- The reference time is the mean of the values measured in c) through d). The deviation of the maximum and minimum values from the mean is the packet timing jitter.

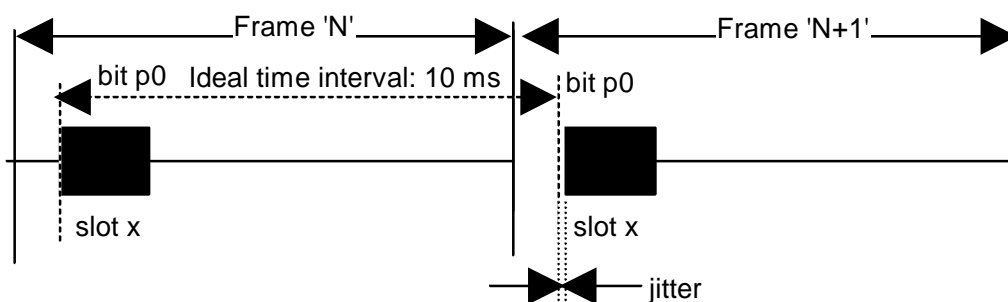

Figure 33: Jitter definition

5.3.3.1.3 Verdict criteria

The packet timing jitter, as measured, shall be less than $\pm 1 \mu\text{s}$ for the duration of this test.

The results obtained shall be compared to the limits in clause 4.5.3.2 in order to prove compliance with the requirement.

5.3.3.2 Measurement of the reference timing accuracy of a RFP

5.3.3.2.1 Test environment

The test shall take place at a test site or in a test fixture. If the EUT is equipped with a temporary connector, the temporary connector may be used in place of the test fixture for this test.

If the EUT has an antenna connector then it shall be used to connect the EUT to the LT.

The test shall take place under extreme test conditions.

5.3.3.2.2 Method of measurement

- a) A minimum of one duplex bearer shall be setup between the LT and the EUT.
- b) Using a sampling method, measure the time, t_{long} , between the transmission of 1 000 frames using the same bit in each slot as the point of reference in each frame.

5.3.3.2.3 Verdict criteria

The EUT is required to conform to the timing accuraciess and stabilities of table 13 at all the applied voltage conditions:

Table 13: Reference timing accuracy's and stability's

Type of EUT	Temperature	
	Nominal	Extreme
Multiple Channel RFP	5 ppm	10 ppm
Single Channel RFP	No test	10 ppm

t_{long} , as measured, shall be within the range of values given in table 14.

Table 14: Allowable timing variations

Timing Accuracy and Stability (ppm)	Ranges of t_{long} Constituting a Pass (seconds)
5	$9,99995 < t_{\text{long}} < 10,00005$
10	$9,99990 < t_{\text{long}} < 10,00010$

RFPs that can work with more than one duplex pair of physical channels per frame are known as multi-channel RFPs. Single channel RFPs can only work with one duplex pair of physical channels per frame (excluding handover situations).

The results obtained shall be compared to the limits in clause 4.5.3.2 in order to prove compliance with the requirement.

5.3.3.3 Measurement of packet transmission accuracy of a PP

5.3.3.3.1 Test environment

The test shall take place at a test site or in a test fixture. If the EUT is equipped with a temporary connector, the temporary connector may be used in place of the test fixture for this test.

If the EUT has an antenna connector then it shall be used to connect the EUT to the LT.

If the EUT has the facilities for advancing the transmission timing from the nominal then this shall be disabled for the duration of this test.

The test shall take place under extreme test conditions.

5.3.3.3.2 Method of measurement

- a) The LT shall place the EUT in a mode whereby the EUT is positioned in a LT specified slot and channel number $c = 5$. If so equipped, the handover function in the EUT shall be disabled. See clause 5.1.8.3 for the appropriate test message reference. The applicant shall declare to the testing laboratory the time required for a system synchronization by the EUT.
- b) Using a sampling method, capture a representation of the RF signal transmitted by the LT and EUT 12 slots apart in the same frame. See figure 34.
- c) The LT shall determine the positions at the EUT of p0 in the slots that were sampled in part b) above.
- d) The delay shall be calculated as the difference in time between the p0 of the LT and the p0 of the EUT.
- e) Steps b) through to d) shall be repeated 100 times.
- f) Steps b) through to e) shall be repeated for RF channels $c = 0$ and 9.
- g) The minimum and maximum delays shall be found over all measurements.

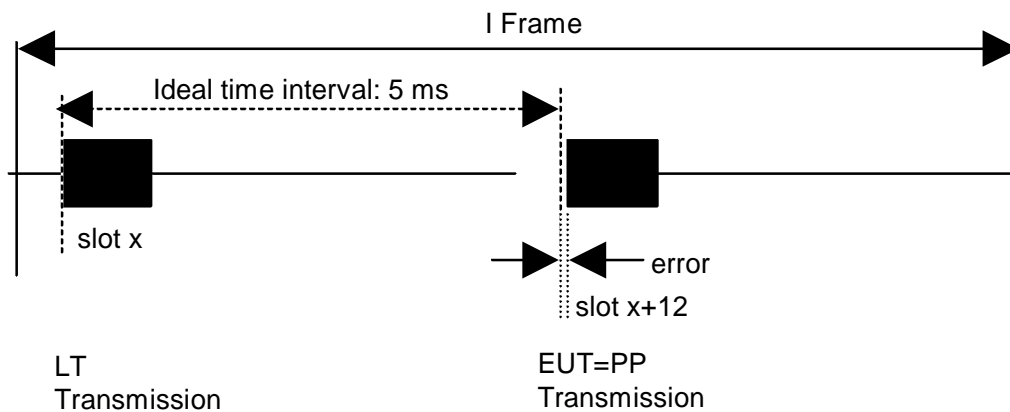

Figure 34: PP packet transmission error definition

5.3.3.3.3 Verdict criteria

The packet timing delay minimum, as measured, shall be greater than $5 \text{ ms} - 2 \mu\text{s}$, the maximum, as measured, shall be less than $5 \text{ ms} + 2 \mu\text{s}$.

The results obtained shall be compared to the limits in clause 4.5.3.2 in order to prove compliance with the requirement.

5.3.4 Transmission burst

5.3.4.1 Test environment

If the EUT has an antenna connector then it shall be used to connect the EUT to the LT.

The test shall take place under nominal and extreme temperature conditions at the nominal supply voltage.

This test shall take place either at a test site, in an anechoic chamber, or in a test fixture for the nominal temperature condition. The extreme temperature testing shall take place inside a temperature chamber with the EUT mounted in a test fixture.

5.3.4.2 Method of measurement

- a) The LT shall place the EUT in a mode whereby the EUT is transmitting at a LT specified slot and RF channel $c = 5$. If so equipped, the handover function in the EUT shall be disabled (see clause 5.1.8.3 for the appropriate test message reference).
- b) Using a sampling measurement method, capture a representation of the EUT's transmit burst's amplitude and modulation. The measurement bandwidth for RF power shall be 1 MHz for the measurement of transmitter idle power (see clause 4.5.4.1.9) and ≥ 3 MHz for all other.
- c) From the array of samples the LT shall calculate the position of bit p0 and the end of the physical packet in each sample to an accuracy of 0,1 μs .
- d) Steps b) and c) are repeated 60 times with intervals of 1 s or longer.
- e) Steps a) to d) shall be repeated for RF channels $c = 0$ and 9.

5.3.4.3 Verdict criteria

The array of power samples shall be compared for a fit within the power-time template as shown in figure 30 and shall comply with the requirements in clauses 4.5.4.1.4, 4.5.4.1.5, 4.5.4.1.6, 4.5.4.1.7, 4.5.4.1.8 and 4.5.4.1.9.

The sampled bursts, as measured, shall conform to the power-time template.

NOTE: As described in clause 4.5.4.1.9, the 20 nW power envelope shown in figure 35 is only applicable when the time between the end of a physical packet and the transmission of p0 of the next physical packet is greater than 54 μs .

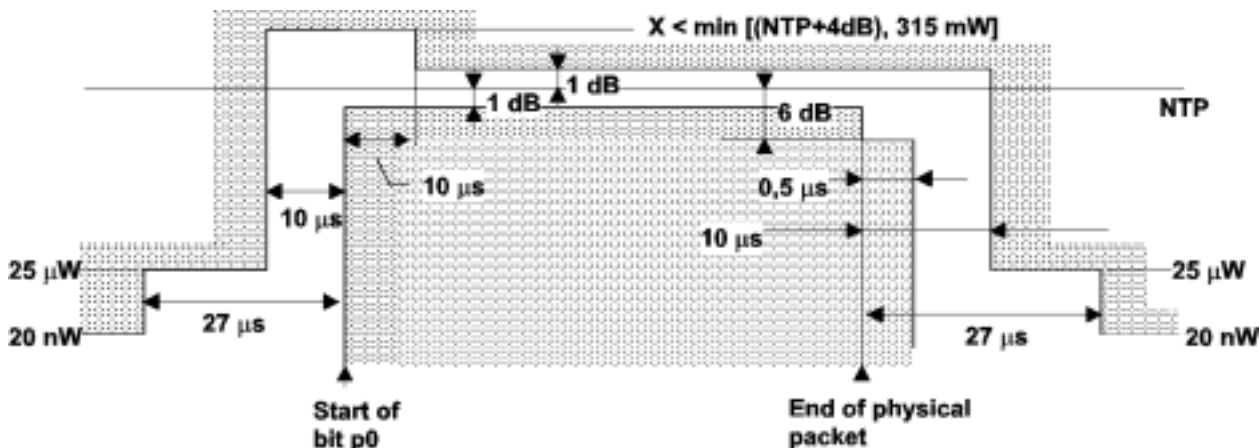

Figure 35: Power-time template

For packets with prolonged preamble, the verdict criteria apply with the notation p0 generally changed to p-16 and the applicant shall declare that the procedure defined in EN 300 175-2 [4], annex D, clause D.3 has been implemented.

The results obtained shall be compared to the limits in clause 4.5.4.2 in order to prove compliance with the requirement.

5.3.5 Transmitted power

5.3.5.1 PP and RFP with an integral antenna

5.3.5.1.1 Test environment

The test shall take place under nominal temperature conditions and at a nominal supply voltage.

This test shall take place either at a test site or in an anechoic chamber for the nominal temperature condition.

5.3.5.1.2 Method of measurement

5.3.5.1.2.1 Introduction

The test consists of both a conducted and a radiated power measurement. For the conducted power measurement, the EUT shall be equipped with a temporary antenna connector. The radiated measurement is performed on a EUT with its own integral antenna.

5.3.5.1.2.2 Measurement of NTP

The test described in clause 5.3.5.2 shall be performed on the EUT with the temporary connector.

The measured result is the NTP.

5.3.5.1.2.3 Measurement of antenna gain

The following measurement is done on the EUT with its own integral antenna:

- a) if the EUT incorporates antenna diversity, then the LT shall command the EUT to operate on a single antenna (see clause 5.1.10.3 for the appropriate test message reference);
- b) the LT shall place the EUT in a mode whereby the EUT is positioned in a LT specified slot and frequency. If so equipped, the handover function in the EUT shall be disabled (see clause 5.1.8.3 for the appropriate test message reference);
- c) a test antenna with a good directivity to limit reflections is connected to a calibrated receiver. The applicant shall indicate the polarization of the integral antenna so that the test antenna can be set to the same polarization as the integral antenna of the EUT throughout this test. The test antenna shall be raised or lowered until a maximum received signal is obtained, except when using a fully anechoic chamber.

The EUT shall be orientated in the reference position using the procedure described in clause 5.1.10.3;

- d) at this position, the LT shall:
 - 1) use the sampling method described in clause 5.1.10.2.2 to capture a representation of a physical packet transmitted by the EUT;
 - 2) determine the position of p_0 in the physical packet and the end of the physical packet;
 - 3) make a measurement of the received power over the 1 MHz bandwidth centered on the DECT RF channel. This power shall be averaged from the start of bit p_0 to the end of the physical packet. This measurement shall be called P_R ;
- e) the substitution antenna shall replace the EUT's transmitter antenna in the same position and polarization. The frequency of the signal generator shall be adjusted to the EUT's nominal channel frequency on which it was transmitting. The test antenna shall be raised or lowered as necessary to ensure that the maximum signal level is received, except when using a fully anechoic chamber. The input signal level to the substitution antenna shall be adjusted until an equal or a known related level to P_R is obtained in the test receiver.

P_T is equal to the power supplied by the signal generator, increased by the known related level if necessary and after corrections due to the gain of the substitution antenna and the cable loss between the signal generator and the substitution antenna;

- f) the antenna gain is the ratio (in dB) between the radiated power P_T and the NTP;
- g) steps b) to f) shall be performed for RF channels $c = 0, 5, \text{ and } 9$.

5.3.5.1.3 Verdict criteria for all EUTs

The NTP per simultaneously active transceiver, as measured, shall be less than P_{NTP} plus the maximum allowable measurement uncertainty for absolute RF power (via an antenna connector) as given in clause 5.2.

The antenna gain as measured shall be less than 12 dB plus the ratio (in dB) between P_{NTP} (250 mW) and NTP plus the maximum allowable measurement uncertainty for absolute RF power (radiated) as given in clause 5.2.

The results obtained shall be compared to the limits in clause 4.5.5.2 in order to prove compliance with the requirement.

5.3.5.2 PP and RFP with external antenna connection(s)

5.3.5.2.1 Test environment

The test shall take place under extreme temperature conditions and at a nominal supply voltage.

This test shall take place either at a test site or in an anechoic chamber for the nominal temperature condition. The extreme temperature testing shall take place inside a temperature chamber.

The EUT shall be connected to the LT via the antenna connector(s).

5.3.5.2.2 Method of measurement

- a) If the EUT incorporates antenna diversity, then the LT shall command the EUT to operate on a single external antenna (see clause 5.1.10.3 for the appropriate test message reference).
- b) The LT shall place the EUT in a mode whereby the EUT is positioned in a LT specified slot and frequency. If so equipped, the handover function in the EUT shall be disabled (see clause 5.1.8.3 for the appropriate test message reference).
- c) A test load shall be connected to each antenna connector.
- d) The LT shall:
 - 1) use the sampling method described in clause 5.1.10.2.2 to capture a representation of a physical packet transmitted by one of the antenna connectors of the EUT into the test load;
 - 2) determine the position of p0 in the physical packet and the end of the physical packet;
 - 3) make a measurement of the power over the 1 MHz bandwidth centered on the DECT RF channel. This power shall be the power delivered to each load simultaneously, averaging from the start of bit p0 of the physical packet, to the end of the physical packet that was sampled in 1).
- e) Steps b) to d) shall be performed for RF channels $c = 0, 5, \text{ and } 9$.

When there is more than one antenna port, the instantaneous power from each antenna port shall be added together. The sum shall be called the NTP.

5.3.5.2.3 Verdict criteria for all EUTs

The NTP per simultaneously active transceiver, as measured, shall be less than P_{NTP} plus the maximum allowable measurement uncertainty as given in clause 5.2.

The results obtained shall be compared to the limits in clause 4.5.5.2 in order to prove compliance with the requirement.

5.3.6 RF carrier modulation

5.3.6.1 Test environment

The test should preferably take place at a test site, otherwise a test fixture or temporary connector shall be used.

If the EUT has an antenna connector then it shall be used to connect the EUT to the LT.

The test shall take place under nominal supply voltage conditions and at a nominal temperature.

5.3.6.2 Method of measurement, Parts 1 and 2

5.3.6.2.1 Introduction

The measurement period of a single positive or negative deviation measurement shall begin one bit time after a 0 to 1 or a 1 to 0 transition in the test data pattern. The measurement period shall end one bit time before the next 0 to 1 or 1 to 0 transition.

5.3.6.2.2 Part 1

- a) Repeat parts a) to d) of clause 5.3.2.2.
- b) Using the samples that were obtained from a), the LT shall calculate the peak frequency deviation within each bit period defined in clause 5.3.6.2.1 in the loopback field of the transmit burst of the EUT, relative to the measured carrier frequency that was calculated in clause 5.3.2. The measurement bandwidth shall be ≥ 3 MHz.
- c) Steps a) to b) shall be repeated until the appropriate number of measurements as shown in table 15 have been made.

Table 15: Measurement repetition

Equipment type	Number of measurements
A-field only transmit	100
Half-slot transmit	40
Full-slot transmit	10
Double-slot transmit	5

5.3.6.2.3 Part 2

- a) Steps a) to d) of clause 5.3.2.2 shall then be repeated using the appropriate sequence as shown in table 16.

Table 16: Test sequence

Equipment type	Test pattern
A-field only transmit	Figure 36
Half-slot transmit	Figure 37
Full-slot transmit	Figure 38
Double-slot	Figure 39

- b) Using the samples that were obtained from part (a) above, the LT shall calculate the peak frequency deviation within each bit period defined in clause 5.3.6.2.1 in the loopback field of the transmit burst of the EUT, relative to the measured carrier frequency that was calculated in clause 5.3.2. The measurement bandwidth shall be ≥ 3 MHz.
- c) Steps a) to b) shall be repeated until the appropriate number of measurements as shown in table 17 have been made.

Table 17: Measurement repetition

Equipment type	Number of measurements
A-field only transmit	100
Half-slot transmit	40
Full-slot transmit	10
Double-slot transmit	5

5.3.6.3 Method of measurement, Parts 3 and 4

5.3.6.3.1 General

The measurement period for the deviation measurement shall begin one bit time after the first 0 to 1 or 1 to 0 transition. The measurement period shall end one bit time before the last 0 to 1 or 1 to 0 transition.

5.3.6.3.2 Part 3

- a) Steps a) to d) of clause 5.3.2.2 shall be repeated with the sequence "0101 0101 0101 0101".
- b) using the samples that were obtained from part a) above, the LT shall calculate the peak frequency deviation within each bit period in the first 16 bits of the synchronization field (preamble) and the loopback field of the transmit burst of the EUT, relative to the measured carrier frequency that was calculated in clause 5.3.2. The measurement bandwidth shall be ≥ 3 MHz.
- c) Steps a) to b) shall be repeated until the appropriate number of measurements as shown in table 18 have been made.

Table 18: Measurement repetition

Equipment type	Number of measurements
A-field only transmit	100
Half-slot transmit	40
Full-slot transmit	10
Double-slot transmit	5

5.3.6.3.3 Part 4

- a) The LT shall place the EUT in a mode whereby the EUT is positioned in a LT specified slot and frequency. If so equipped, the handover function in the EUT shall be disabled (see clause 5.1.8.3 for the appropriate test message reference).
- b) The EUT shall be placed in a test mode whereby it performs the loopback function as referenced in clause 5.1.8.3.
- c) The LT shall transmit a packet with a test sequence in the loopback field of the packet. This test sequence shall be such that the sequence 0101 0101 0101 0101 is transmitted at the antenna of the EUT in the loopback field of the reply packet.
- d) Using the sampling method described in clause 5.1.10.2.2 capture a representation of the EUT's transmitted RF signal after allowing the EUT to be in an Active-locked state (see EN 300 175-3 [5] clause 4.3.1) for more than 1 s. The measurement bandwidth shall be ≥ 3 MHz.
- e) Using the samples that were obtained from d) above, the LT shall calculate the average frequency of the last 14 bits of the first 16 bits of the synchronization field.
- f) Using the samples that were obtained from d) above, the LT shall calculate the average frequency of the first 14 bits of the last 16 bits of the loopback field.
- g) Steps c) to f) shall be repeated until 200 measurements have been made. The frequency drift is the difference between the mean of the measurements taken in e) and the mean of the measurements taken in f).

5.3.6.4 Verdict criteria for Part 1

The peak frequency deviation as measured in part 1 shall be greater than ± 259 kHz and less than ± 403 kHz.

The results obtained shall be compared to the limits in clause 4.5.6.2 in order to prove compliance with the requirement.

5.3.6.5 Verdict criteria for Part 2

The peak frequency deviation as measured in part 2 shall be greater than ± 202 kHz and less than ± 403 kHz.

The results obtained shall be compared to the limits in clause 4.5.6.2 in order to prove compliance with the requirement.

5.3.6.6 Verdict criteria for Part 3

The peak frequency deviation as measured in part 3 shall be greater than ± 202 kHz and less than ± 403 kHz.

The results obtained shall be compared to the limits in clause 4.5.6.2 in order to prove compliance with the requirement.

5.3.6.7 Verdict criteria for Part 4

The rate of change as measured in part 4 shall not be greater than 15 kHz per slot plus the maximum measurement uncertainty calculated from the allowable uncertainty in the relative drift radio frequency measurements involved (see clause 5.2). This implies that the drift in slot shall be between -17 kHz per slot and +17 kHz per slot, as measured.

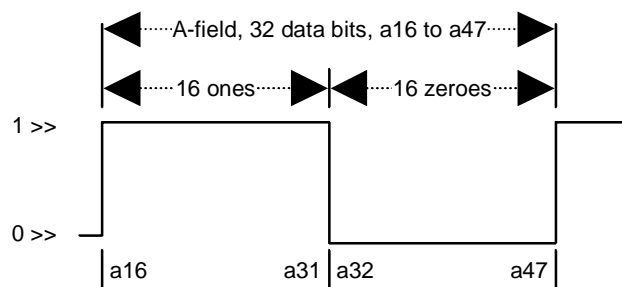
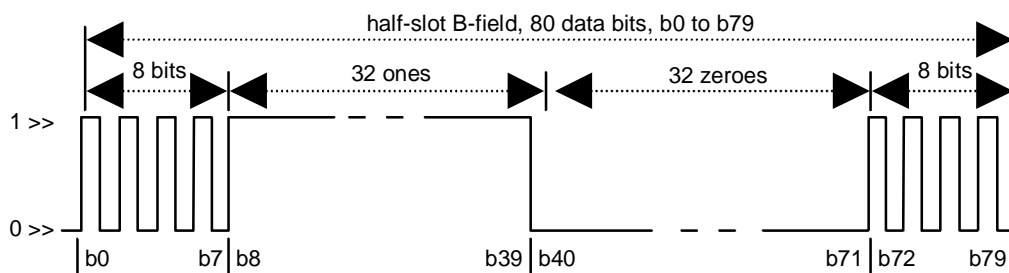
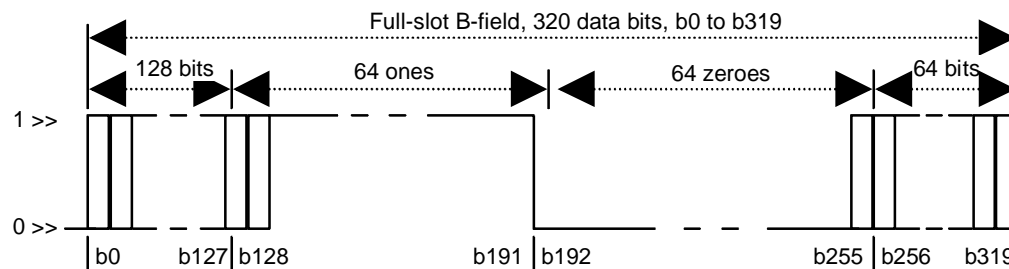

Figure 36: Test packet structure for case 2, A-field



NOTE: Bits b_0 to b_7 and b_{72} to b_{79} are alternating 1s and 0s with the even order bits (b_0, b_2, b_4, \dots) set to "1" and the odd-order bits (b_1, b_3, b_5, \dots) set to "0".

Figure 37: Test packet structure for case 2, half-slot



NOTE: Bits b_0 to b_{127} and b_{256} to b_{319} are alternating 1 s and 0 s.

Figure 38: Test packet transmission for case 2, full-slot

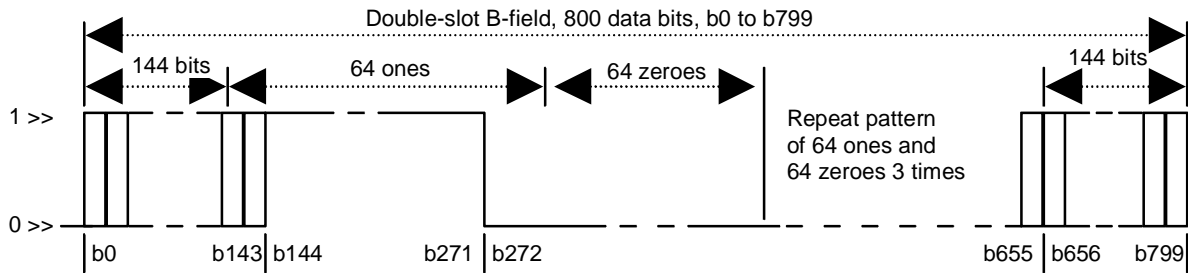

NOTE: Bits b_0 to b_{143} and b_{656} to b_{799} are alternating 1 s and 0 s.

Figure 39: Test packet transmission for case 2, double-slot

NOTE: The above fields, (A-field for figure 36, half-slot for figure 37, full-slot for figure 38, and double-slot for figure 39) are defined in EN 300 175-3 [5] clauses 6.2.1.2 and 6.2.1.3. The X-field portions of the half-slot, full-slot, and double-slot B-fields depicted in figures 37, 38 and 39 are not shown.

The results obtained shall be compared to the limits in clause 4.5.6.2 in order to prove compliance with the requirement.

5.3.7 Unwanted RF power radiation

5.3.7.1 General test conditions

If the EUT is equipped with antenna diversity, the EUT shall have the diversity operation defeated for the following tests (see clause 5.1.8.3 for the appropriate test message reference).

5.3.7.2 Emissions due to modulation

5.3.7.2.1 Test environment

The test shall take place at a test site or using a test fixture for equipment with integral antenna.

The test shall take place under nominal supply voltage conditions and at a nominal temperature.

5.3.7.2.2 Method of measurement

a) If the EUT has an external antenna connector then this shall be used to connect the EUT to the LT. Otherwise, the transmitted signal shall be applied to the LT via a coupling device which provides the appropriate signal level to the system. The analyzing system in the LT shall be operated under the following conditions:

- frequency sweep: 1 MHz;
- resolution bandwidth: 100 kHz;
- video bandwidth: greater than resolution bandwidth;
- integration: across the frequency sweep;
- peak hold: on;
- sweep time: greater than 12 s;
- filtering type: synchronously tuned.

The centre frequencies of the DECT RF channels are defined in clause 4.5.1.2.

The total sample time used for measurement is 60 % to 80 % of the duration of the physical packet, starting before 25 % of the slot time has expired but after the transmission of the synchronization word. The LT shall determine the start of the physical packet (bit p0) transmitted by the EUT.

- b) The LT shall place the EUT in a mode whereby the EUT is positioned in a LT specified slot and frequency. If so equipped, the handover function in the EUT shall be disabled. See clause 5.1.8.3 for the appropriate test message reference.
- c) The EUT shall be placed in a test mode whereby it performs the loopback function as referenced in clause 5.1.8.3.
- d) A test modulation signal D-M2 (see clause 5.1.7.8) is generated by the LT.
- e) Using the analyzing system, a measurement of the EUT's transmitted power on channel M is made during the sampling time. This power measurement shall be called P_{ref} .

NOTE: This measurement becomes the reference power for the power measurements of the other channels.

- f) Using the method described in e), a measurement on all the other DECT channels shall be made and recorded in dB as a value relative to P_{ref} . These shall be called P_{rm-2} , P_{rm-1} , P_{rm+1} , P_{rm+2} , etc., corresponding to the measurements made on channels $Y = M - 2$, $Y = M - 1$, $Y = M + 1$ and $Y = M + 2$.
- g) Using the measured value of transmitted power, NTP, from clause 10 for channel $Y = M$, the LT shall calculate the power emissions on each channel.

EXAMPLE: Emissions on channel $Y = M + 1$:

$$= NTP(\text{dBm}) + P_{rm+1}(\text{dB}).$$

- h) The value calculated in g) shall be converted from dBm to Watts.
- i) Steps b) through h) shall be performed with the EUT's transmitter placed on DECT RF channels $c = 0, 5, \text{ and } 9$.

5.3.7.2.3 Verdict criteria

The unwanted emissions, as measured, shall not be greater than the power levels stated in table 19.

Table 19: Levels of emissions due to modulation

Emissions on RF Channel "Y"	Maximum Power Level
$Y = M \pm 1$	160 μW
$Y = M \pm 2$	1 μW
$Y = M \pm 3$	80 nW
Y = any other DECT channel	40 nW

For $Y = \text{"any other DECT channel"}$, the maximum power level shall be less than 40 nW except for one instance per M of a 500 nW signal.

"M" is the EUT transmit channel and "Y" is a legal DECT channel other than the EUT transmit channel.

The results obtained shall be compared to the limits in clause 4.5.7.2.2 in order to prove compliance with the requirement.

5.3.7.3 Emissions due to transmitter transients

5.3.7.3.1 Test environment

The test shall take place at a test site or using a test fixture for equipment with integral antenna.

The test shall take place under nominal supply voltage conditions and at a nominal temperature.

5.3.7.3.2 Method of measurement

- a) If the EUT has an external antenna connector then this shall be used to connect the EUT to the LT. Otherwise, the transmitted signal shall be applied to the LT via a coupling device which provides the appropriate signal level to the system. The analyzing system in the LT shall be operated under the following conditions:
- frequency sweep: 1 MHz;
 - resolution bandwidth: 100 kHz;
 - video bandwidth: greater than resolution bandwidth;
 - averaging: none;
 - peak hold: on;
 - filtering type: 4 or 5 pole synchronously tuned.

The centre frequencies of the DECT RF channels are defined in clause 4.3.1.1.

- b) The LT shall place the EUT in a mode whereby the EUT is positioned in a LT specified slot and frequency. If so equipped, the handover function in the EUT shall be disabled (see clause 5.1.8.3 for the appropriate test message reference).
- c) The EUT shall be placed in a test mode whereby it performs the loopback function as referenced in clause 5.1.8.3. When testing a RFP, the test shall be performed either with the dummy bearer switched off when the traffic bearer is active, or with the dummy bearer placed on the same RF carrier as the traffic bearer as referenced in clause 5.1.8.4.
- d) A test modulation signal D - M2 (see clause 5.1.7.8) generated by the LT.
- e) The analyzing system centre frequency is positioned at the centre of the DECT RF channel being measured.
- f) The analyzing system shall initiate a power measurement procedure conforming to the limits specified in clause 5.2 table 6.
- g) Using the measured values obtained from e) to f), the LT shall select the highest recorded value within the sweep. This value shall be compared with the verdict criteria.
- h) Steps e) to g) are repeated for all DECT RF channels other than the one on which the EUT is transmitting.
- i) Steps b) to h) shall then be repeated until measurements have been made with the EUT's transmitter placed on all 10 DECT RF channels.

5.3.7.3.3 Verdict criteria

The unwanted emissions, as measured, shall not be greater than the power levels stated in table 20.

Table 20: Levels of emissions due to transients

Emissions on RF Channel "Y"	maximum peak power Level
Y = M ± 1	250 µW
Y = M ± 2	40 µW
Y = M ± 3	4 µW
Y = any other DECT channel	1 µW

"M" is the EUT transmit channel and "Y" is a legal DECT channel other than the EUT transmit channel.

The results obtained shall be compared to the limits in clause 4.5.7.3.2 in order to prove compliance with the requirement.

5.3.7.4 Emissions due to intermodulation

5.3.7.4.1 Test environment

If the EUT is a PP equipped with an integral antenna, the EUT and the test antenna shall be mounted in the reference test arrangement as specified in clause 5.1.12.1.

If the EUT is a RFP with an integral antenna, the EUT and the test antenna shall be mounted in the reference testing arrangement as specified in clause 5.1.12.2.

If the EUT has an external antenna connector then this test shall preferably take place at a test site, otherwise a test fixture may be used.

The test shall take place under nominal supply voltage conditions and at a nominal temperature.

5.3.7.4.2 Method of measurement

a) If the EUT has an external antenna connector then this shall be used to connect the EUT to the LT. Otherwise, the transmitted signal shall be applied to the LT via a coupling device which provides the appropriate signal level to the system. The analyzing system in the LT shall be operated under the following conditions:

- frequency sweep: 1 MHz;
- resolution bandwidth: 100 kHz;
- video bandwidth: greater than resolution bandwidth;
- integration: across the frequency sweep;
- peak hold: on;
- sweep time: greater than 12 s;
- filtering type: synchronously tuned.

The centre frequencies of the DECT RF channels are defined in clause 4.5.2.1..

The total sample time used for measurement is 60 % to 80 % of the duration of the physical packet, starting before 25 % of the slot time has expired but after the transmission of the synchronization word. The LT shall determine the start of the physical packet (bit p0) transmitted by the EUT.

- b) The EUT shall be placed in a mode whereby two of the transceivers shall be made to operate on the same slot in the frame but on different DECT RF channels. The RF channels shall be $c = 0$ and $c = 9$. If so equipped, the handover function in the EUT shall be disabled (see clause 5.1.8.3 for the appropriate test message reference).
- c) The EUT shall be placed in a test mode whereby it performs the loopback function for both transceivers as referenced in clause 5.1.8.3.
- d) A test modulation signal D - M2 (see clause 5.1.7.4.4) is generated by the LT.
- e) Using the analyzing system, a measurement of the transmitted powers on channels $M = 0$ and $M = 9$ shall be made during the sample time for a transmitter in the EUT. These measurements shall be called $P_{\text{ref}0}$ and $P_{\text{ref}9}$.
- f) The EUT shall be placed in a mode whereby two of the transmitters shall be made to operate on the same slot in the frame but on different DECT RF channels. The RF channels shall be $M = 3$ and $M = 6$. If so equipped, the handover function in the EUT shall be disabled (see clause 5.1.8.3 for the appropriate test message reference).
- g) Using the analyzing system, a measurement of the power levels on channels $c = 0$ and $c = 9$ shall be made during the sample time for a transmitter in the EUT. These power measurements shall be called $P_{\text{m}0}$ and $P_{\text{m}9}$.
- h) Using the NTPs for $c = 0$ and $c = 9$ (as defined in clause 4.5.5), the LT shall calculate the power emissions on channels $c = 0$ and $c = 9$. The calculation shall be performed as follows:
 - 1) emissions on channel 0:

$$= NTP_0(\text{dBm}) - P_{\text{ref}0}(\text{dBm}) + P_{m0}(\text{dBm});$$

2) emissions on channel 9:

$$= NTP_9(\text{dBm}) - P_{\text{ref}9}(\text{dBm}) + P_{m9}(\text{dBm}).$$

- i) Steps b) to h) shall be repeated until measurements have been made with all combinations of the EUT's transmitters.

5.3.7.4.3 Verdict criteria

The unwanted emissions due to intermodulation as measured shall not be greater than 1 μW in the measurement channels.

The results obtained shall be compared to the limits in clause 4.5.7.4.2 in order to prove compliance with the requirement.

5.3.7.5 Spurious emissions when allocated a transmit channel

5.3.7.5.1 Radiated emissions

5.3.7.5.1.1 Test environment

The test shall take place at a test site.

For EUTs with external antenna connectors, test loads shall be attached to each connector.

The test shall take place under nominal supply voltage conditions and at a nominal temperature.

5.3.7.5.1.2 Method of measurement

- a) The analyzing system in the LT shall be operated under the following conditions:

- frequency sweep: as required for frequency range;
- resolution bandwidth: refer to table 21;
- display bandwidth: greater than resolution bandwidth;
- averaging: refer to table 21;
- peak hold: refer to table 21;
- filtering type: synchronously tuned.

The sweep time shall be chosen to be slow enough to ensure that the LT is capable of capturing at least one burst spurious signal for every measurement point.

NOTE: This may be achieved by using the following formula:

$$\text{sweep time} > \frac{2 \times (\text{PRI} \times \text{frequency span})}{\text{resolution bandwidth}}$$

where PRI = pulse repetition interval = 10 ms.

Table 21: Measurement parameter settings

Frequency offset from edge of band	Resolution Bandwidth	Peak Hold	Averaging
0 MHz to 2 MHz	30 kHz	on	none
2 MHz to 5 MHz	30 kHz	on	none
5 MHz to 10 MHz	100 kHz	on	none
10 MHz to 20 MHz	300 kHz	on	none
20 MHz to 30 MHz	1 MHz	on	none
30 MHz to 4000 MHz	3 MHz	on	none
NOTE: The highest frequency of measurement should not exceed 4 GHz for radiated measurements.			

Measurements shall not be made for transmissions on the RF channel closest to the nearest band edge for frequency offsets of up to 2 MHz.

The centre frequencies of the DECT RF channels are defined in clause 4.5.2.1. b) The LT shall place the EUT in a mode whereby the EUT is positioned in a LT specified slot and frequency. If so equipped, the handover function in the EUT shall be disabled (see clause 5.1.8.3 for the appropriate test message reference).

- c) The EUT shall be placed in a test mode whereby it performs the loopback function as referenced in clause 5.1.8.3. When testing a RFP, the test shall be performed either with the dummy bearer switched off when the traffic bearer is active, or with the dummy bearer placed on the same RF carrier as the traffic bearer as referenced in clause 5.1.8.4.
- d) A test modulation signal D - M2 (see clause 5.1.7.4.4) is generated by the LT.
- e) The LT shall initiate a power measurement procedure conforming to the limits specified in clause 5.2 table 11.
- f) The test shall be carried out over the RF ranges from 30 MHz to 4 GHz and the power measurements shall be performed using the resolution bandwidth as indicated in table 21.

5.3.7.5.1.3 Verdict criteria

The spurious emissions, as measured, shall not be greater than 250 nW at frequencies below 1 GHz and 1 μ W at frequencies above 1 GHz.

In addition, not regarding up to 2 instances of a continuous - wave spurious signal for PPs for which the total peak power level shall be less than 250 nW as measured in a 3 MHz measurement bandwidth, the peak power level shall be less than 20 nW in a 100 kHz measuring bandwidth for the following broadcast bands:

- 47 MHz to 74 MHz;
- 87,5 MHz to 108 MHz;
- 108 MHz to 118 MHz;
- 174 MHz to 230 MHz;
- 470 MHz to 862 MHz.

The results obtained shall be compared to the limits in clause 4.5.7.5.2 in order to prove compliance with the requirement.

5.3.7.5.2 Conducted spurious emissions

5.3.7.5.2.1 Test environment

The test shall take place under nominal supply voltage conditions and at a nominal temperature.

5.3.7.5.2.2 Method of measurement

- a) The EUT shall be connected to the LT via the external antenna connector. The external antenna connector may either be temporary or permanent.

Table 22: Measurement parameter settings

Frequency offset from edge of band	Resolution Bandwidth	Peak Hold	Averaging
0 MHz to 2 MHz	30 kHz	on	none
2 MHz to 5 MHz	30 kHz	on	none
5 MHz to 10 MHz	100 kHz	on	none
10 MHz to 20 MHz	300 kHz	on	none
20 MHz to 30 MHz	1 MHz	on	none
30 MHz to 12 750 MHz	3 MHz	on	none

- b) Carry out the test a) to f) in clause 5.3.7.5.1.2 excepting test e), The test shall be carried out over the RF ranges from 30 MHz to 12,75 GHz for EUT with permanent external antenna connector. For EUT with integral antennas only the test shall be carried out over the RF ranges from 4 GHz to 12,75 GHz via temporary antenna connector. The power measurements shall be performed using the resolution bandwidth as indicated in table 22.

5.3.7.5.2.3 Verdict criteria

The spurious emissions, as measured, shall not be greater than 250 nW at frequencies below 1 GHz and 1 μ W at frequencies above 1 GHz.

In addition, not regarding up to 2 instances of a continuous - wave spurious signal for PPs for which the total peak power level shall be less than 250 nW as measured in a 3 MHz measurement bandwidth, the peak power level shall be less than 20 nW in a 100 kHz measuring bandwidth for the following broadcast bands:

- 47 MHz to 74 MHz;
- 87,5 MHz to 108 MHz;
- 108 MHz to 118 MHz;
- 174 MHz to 230 MHz;
- 470 MHz to 862 MHz.

The results obtained shall be compared to the limits in clause 4.5.7.5.2 in order to prove compliance with the requirement.

5.3.8 Radio receiver testing

5.3.8.1 Radio receiver sensitivity

5.3.8.1.1 Test environment

The test should preferably take place at a test site, otherwise a test fixture or temporary connector shall be used.

If the EUT has an antenna connector then it shall be used to connect the EUT to the LT.

The test shall take place under nominal supply voltage conditions and at a nominal temperature.

5.3.8.1.2 Method of measurement

- a) The EUT shall be oriented in the reference position as determined in clause 5.1.10.3 if no antenna connector is available.
- b) The LT shall be programmed to set its RF transmission to a power level such that 60 dB μ V/m (-83 dBm) shall be present at the input of the EUT receiver.
- c) The LT shall place the EUT in a mode whereby the EUT is positioned in a LT specified slot and RF channel c = 5. If so equipped, the handover function in the EUT shall be disabled (see clause 5.1.8.3 for the appropriate test message reference).

- d) The EUT shall be placed in a test mode whereby it performs the loopback function as referenced in clause 5.1.8.3.
- e) A test modulation signal D - M2 (see clause 5.1.7.4.4) is generated by the LT.
- f) The LT shall calculate the BER of the EUT as determined in clause 5.1.10.4 and annexes D and E.
- g) The LT shall offset the frequency of the test signal by 50 kHz and repeat parts b) to f). This sequence of steps shall be repeated twice to include both positive and negative frequency offsets.
- h) Steps b) to f) shall be repeated for RF channels $c = 0$ and 9.

5.3.8.1.3 Verdict criteria

The BER of the EUT, as measured, shall be less than or equal to 0,001 for the duration of this test.

The results obtained shall be compared to the limits in clause 4.5.8.1.2 in order to prove compliance with the requirement.

5.3.8.2 Radio receiver reference BER and FER

5.3.8.2.1 Test environment

The test shall take place at a test site or using a test fixture for equipment with integral antenna.

If the EUT has an antenna connector then it shall be used to connect the EUT to the LT.

The test shall take place under nominal supply voltage conditions and at a nominal temperature.

5.3.8.2.2 Method of measurement

- a) The EUT shall be oriented in the reference position as determined in clause 5.1.10.3 if no antenna connector is available.
- b) The LT shall be programmed to set its RF transmission to a power level of 70 dB μ V/m (-73 dBm) at the input of the EUT receiver.
- c) The LT shall place the EUT in a mode whereby the EUT is positioned in a LT specified slot and RF channel $c = 5$ with handover disabled (see clause 5.1.8.3 for the appropriate test message reference).
- d) The EUT shall be placed in a test mode whereby it performs the loopback function as referenced in clause 5.1.8.3.
- e) A test modulation signal D - M2 (see clause 5.1.7.4.4) is generated by the LT.
- f) The LT shall calculate the BER and FER of the EUT as determined in clause 5.1.10.4 and annexes D and E.
- g) Steps b) to f) shall be repeated for RF channels $c = 0$ and 9.

5.3.8.2.3 Verdict criteria

The BER of the EUT, as measured, shall be 0,00001 or less. The FER of the EUT, as measured, shall be 0,0005 or less.

The results obtained shall be compared to the limits in clause 4.5.8.2.2 in order to prove compliance with the requirement.

5.3.8.3 Radio receiver interference performance

5.3.8.3.1 Test environment

The test shall take place at a test site or using a test fixture for equipment with integral antenna.

If the EUT has an antenna connector then it shall be used to connect the EUT to the LT.

The test shall take place under nominal supply voltage conditions and at a nominal temperature.

5.3.8.3.2 Method of measurement

- a) The EUT shall be oriented in the reference position as determined in clause 5.1.10.3 if no antenna connector is available.
- b) The LT shall be programmed to set its RF transmission to a power level of 70 dB μ V/m (-73 dBm) at the input of the EUT receiver.
- c) The LT shall place the EUT in a mode whereby the EUT is positioned in a LT specified slot and RF channel $c = 5$. If so equipped, the handover function in the EUT shall be disabled (see clause 5.1.8.3 for the appropriate test message reference).
- d) The EUT shall be placed in a test mode whereby it performs the loopback function as referenced in clause 5.1.8.3.
- e) A test modulation signal D - M2 (see clause 5.1.7.4.4) is generated by the LT.
- f) The LT shall transmit in addition to the D - M2 data test pattern, a modulated DECT - like carrier (see clause 5.1.7.5) on channel "Y" whose level is determined by table 23.

Table 23: Interferer levels

Interferer on RF Channel "Y"	Interferer signal strength	
	(dB μ V/m)	(dBm)
Y = M	59	-84
Y = M \pm 1	83	-60
Y = M \pm 2	104	-39
Y = any other DECT channel	110	-33

The RF carriers "Y" shall include the three nominal DECT RF carrier positions immediately outside each edge of the DECT band.

- g) The LT shall calculate the BER of the EUT as determined in clause 5.1.10.4 and annexes D and E.
- h) Steps b) to g) shall be repeated so that the single interfering DECT - like carrier has been placed on all the remaining DECT channels. Table 13 indicates the amplitude of the interferer.
- i) Steps b) to h) shall be repeated for RF channels $c = 0$ and 9.

5.3.8.3.3 Verdict criteria

The BER of the EUT, as measured, shall be 0,001 or less.

The results obtained shall be compared to the limits in clause 4.5.8.3.2 in order to prove compliance with the requirement.

5.3.8.4 Radio receiver blocking case 1: owing to signals occurring at the same time but on other frequencies

5.3.8.4.1 Test environment

The test shall take place at a test site or using a test fixture for equipment with integral antenna.

If the EUT has an antenna connector then it shall be used to connect the EUT to the LT.

The test shall take place under nominal supply voltage conditions and at a nominal temperature.

5.3.8.4.2 Method of measurement

- a) The EUT shall be oriented in the reference position as determined in clause 5.1.10.3 if no antenna connector is available.
- b) The power level of the RF transmission from the LT shall be set to -80 dBm.
- c) The LT shall place the EUT in a mode whereby the EUT is positioned in a LT specified slot and frequency (F_C). The frequency chosen shall be RF channel $c = 5$ of the DECT RF channels. If so equipped, the handover function in the EUT shall be disabled (see clause 5.1.8.3 for the appropriate test message reference).
- d) The EUT shall be placed in a test mode whereby it performs the loopback function as referenced in clause 5.1.8.3.
- e) A test modulation signal D - M2 (see clause 5.1.7.4.4) is generated by the LT.
- f) The LT shall transmit in addition to the D -M2 signal a single continuous - wave interferer with an equivalent frequency change rate not exceeding the rate shown in table 24

Table 24: Frequency change rate

Equipment type	Frequency change rate
A-field only	1 MHz/s
half-slot	2,5 MHz/s
full-slot	10 MHz/s
double-slot	20 MHz/s

The frequency (f) and levels are determined by table 25. If discrete frequency steps are used, the step shall not exceed 1 MHz.

The EUT shall operate on the declared frequency allocation, see clause 4.5.11.4, with the low band edge F_L in MHz and the high band edge F_U in MHz.

Table 25: Interferer levels

Frequency (f)	Continuous wave interferer level	
	For radiated measurements dB μ V/m	For conducted measurements dBm
$25 \text{ MHz} \leq f < F_L - 100 \text{ MHz}$	120	-23
$F_L - 100 \text{ MHz} \leq f < F_L - 5 \text{ MHz}$	110	-33
$ f - F_C > 6 \text{ MHz}$	100	-43
$F_U + 5 \text{ MHz} < f \leq F_U + 100 \text{ MHz}$	110	-33
$F_U + 100 \text{ MHz} < f \leq 12,75 \text{ GHz}$	120	-23

- g) The LT shall for frequencies and conditions defined under part f) monitor bit errors with time intervals not exceeding 1 s.
- h) at frequencies where 1 or more errors are found, the LT shall calculate the BER of the EUT as determined in clause 5.1.10.4 and annexes D and E. If the measured BER exceeds 0,001 the frequency shall be recorded.
- i) For all frequencies recorded under h) the measurement and recording procedure shall be repeated, but with the interferer level decreased to 100 dB μ V/m for radiated measurements or -43 dBm for conducted measurements.
- j) For all frequencies recorded under i), the measurement and recording procedure shall be repeated, but with the interferer level decreased to 80 dB μ V/m for radiated measurements or -63 dBm for conducted measurements.

5.3.8.4.3 Verdict criteria

A spurious response frequency is defined as the nominal DECT carrier frequency F_g closest to a frequency recorded under part h).

NOTE: F_g is defined in EN 300 175-2 [4], clause 4.1.1 as the nominal DECT RF carrier whose centre frequency is generated by the formula:

$$F_g = F_0 - g \times 1\,728 \text{ kHz};$$

where $F_0 = 1\,897,344 \text{ MHz}$ and g is any integer.

An occurrence is defined as a group of up to 3 spurious response frequencies with consecutive values of g . Two occurrences are defined as separate if between these occurrences there is at least one nominal DECT carrier frequency that is not a spurious response frequency.

Every recorded frequency is defined to be related to the closest spurious response frequency.

Every recorded frequency is defined to be related to the occurrence which contains the related spurious response frequency.

All frequencies recorded under h) shall only relate to a maximum of 8 separated occurrences.

All frequencies recorded under i) shall only relate to a maximum of 4 separated occurrences.

No frequency shall have been recorded under j).

The results obtained shall be compared to the limits in clause 4.5.8.4.2 in order to prove compliance with the requirement.

5.3.8.5 Radio receiver blocking case 2: owing to signals occurring at a different time

5.3.8.5.1 Test environment

The test shall take place at a test site or using a test fixture for equipment with integral antenna.

If the EUT has an antenna connector then it shall be used to connect the EUT to the LT.

The test shall take place under nominal supply voltage conditions and at a nominal temperature.

5.3.8.5.2 Method of measurement

- a) The EUT shall be orientated in the reference position as determined in clause 5.1.10.3 if no antenna connector is available.
- b) The LT shall be programmed to set its RF transmission to a power level of $70 \text{ dB}\mu\text{V/m}$ (-73 dBm) at the input of the EUT receiver.
- c) The LT shall place the EUT in a mode whereby the EUT is positioned in RF channel $c = 5$ and slot-pair N (i.e. slot N and slot $N + 12$ with $N \geq 2$). If so equipped, the handover function in the EUT shall be disabled (see clause 5.1.8.3 for the appropriate test message reference).
- d) The EUT shall be placed in a test mode whereby it performs the loopback function as referenced in clause 5.1.8.3.
- e) A test modulation signal D-M2 (see clause 5.1.7.4.4) is generated by the LT.
- f) The LT shall transmit at the same time a DECT-like physical packet interferer at a level of -14 dBm ($129 \text{ dB}\mu\text{V/m}$) in slot $N - 2$ for measuring a PT and slot $(N + 12) - 2$ for measuring an FT (see clause 5.1.7.5 for a description of this interferer).

The power level of any emissions by the LT shall be less than -93 ($50 \text{ dB}\mu\text{V/m}$) dBm on slot $N - 1$ for measuring a PT and on slot $(N + 12) - 1$ for measuring an FT.

- g) The LT shall be programmed to set its RF transmission to a power level of 60 dB μ V/m (-83 dBm) at the input of the EUT receiver in slot N for measuring a PT and in slot N + 12 for measuring an FT.
- h) The LT shall calculate the BER of the EUT as determined in clause 5.1.10.4 and annexes D and E.
- i) Steps b) to h) shall be repeated with the EUTs receiver placed on RF channels c = 0 and 9.

5.3.8.5.3 Verdict criteria

The BER of the EUT as measured shall be 0,001 or less for the duration of this test.

The results obtained shall be compared to the limits in clause 4.5.8.5.2 in order to prove compliance with the requirement.

5.3.8.6 Receiver intermodulation performance

5.3.8.6.1 Test environment

The test should preferably take place at a test site, otherwise a test fixture shall be used.

If the EUT has an antenna connector then it shall be used to connect the EUT to the LT.

The test shall take place under nominal supply voltage conditions and at a nominal temperature.

5.3.8.6.2 Method of measurement

- a) The EUT shall be oriented in the reference position as determined in clause 5.1.10.3 if no antenna connector is available.
- b) The LT shall be programmed to set its RF transmission level to a power level of 63 dB μ V/m (-80 dBm) at the input of the EUT receiver.
- c) The EUT's RF channel is recorded as channel "M".
- d) The LT shall place the EUT in a mode whereby the EUT is positioned in a LT specified slot and frequency. If so equipped, the handover function in the EUT shall be disabled (see clause 5.1.8.3 for the appropriate test message reference).
- e) The EUT shall be placed in a test mode whereby it performs the loopback function as referenced in clause 5.1.8.3.
- f) A test modulation signal D - M2 (see clause 5.1.7.4.4) is generated by the LT.
- g) The LT shall then transmit in addition to the D - M2 test signal, a modulated DECT-like carrier "B" and a continuous-wave carrier "A" whose intermodulation product is present within the DECT channel "M" of the EUT. The level of these carriers shall be set to -48 dBm (95 dB μ V/m) at the receiver input of the EUT. The LT shall calculate the BER of the EUT as determined in clause 5.1.10.4 and annexes D and E. The measurement shall be performed 4 times with the interfering carriers and the EUT receive channel positioned on the DECT RF channels as given in table 26.

Table 26: RF carrier combinations

M	A	B
5	7	9
5	3	1
0	2	4
9	7	5

5.3.8.6.3 Verdict criteria

The BER of the EUT, as measured, shall be less than 0,001 for the duration of this test.

The results obtained shall be compared to the limits in clause 4.5.8.6.2 in order to prove compliance with the requirement.

5.3.8.7 Spurious emissions when the PP has no allocated transmit channel

5.3.8.7.1 Test environment

The test shall take place at a test site.

Connection between the EUT and the LT shall be made by means of a test antenna.

The test shall take place under nominal supply voltage conditions and at a nominal temperature.

5.3.8.7.2 Method of measurement

- a) The analyzer controls shall be set to the following:
 - frequency span: as required for frequency range;
 - resolution bandwidth: 1 MHz (in DECT band) 100 kHz (outside DECT band);
 - video bandwidth: greater than resolution bandwidth;
 - averaging: none;
 - peak hold: on;
 - filtering type: synchronously tuned for measurements in the DECT band.
- b) The EUT shall be oriented in the reference position as determined in clause 5.1.10.3.
- c) The EUT shall be placed into a receive or idle mode for the duration of this test.
- d) The test shall be carried out across the RF range of 30 MHz to 4 GHz and the power measurements shall be performed using the resolution bandwidths as indicated in a).

5.3.8.7.3 Verdict criteria (outside the DECT band)

The EUT shall conform to the following limits:

- the emissions as measured shall not be greater than 2 nW between 30 MHz and 1 GHz; and
- between 1 GHz and 4 GHz, the emissions as measured shall not exceed 20 nW.

The results obtained shall be compared to the limits in clause 4.5.8.7.2.1 in order to prove compliance with the requirement.

5.3.8.7.4 Verdict criteria (inside the DECT band)

The EUT shall conform to the following limits:

- the power level as measured of any spurious emissions shall not exceed 2 nW in a 1 MHz bandwidth.

The following exceptions are allowed:

- a) in one 1 MHz, the maximum allowable Effective Radiated Power (ERP) shall be 20 nW;
- b) in up to two bands of 30 kHz, the maximum ERP shall be less than 250 nW.

The results obtained shall be compared to the limits in clause 4.5.8.7.2.2 in order to prove compliance with the requirement.

5.3.9 Intersystem synchronization (FP only)

5.3.9.1 Test environment

The test shall take place at a test site or using a test fixture for equipment with integral antenna.

If the EUT has an antenna connector then it shall be used to connect the EUT to the LT.

The test shall take place under nominal supply voltage conditions and at a nominal temperature.

5.3.9.2 Wired synchronization ports

5.3.9.2.1 FP as a master

5.3.9.2.1.1 Method of measurement

The applicant shall declare to the testing laboratory the time required for system synchronization by the EUT:

- a) the EUTs' synchronization port shall be connected to the LT's input port;
- b) a bearer shall be setup between the EUT and the LT;
- c) the LT shall:
 - 1) use the sampling method described in clause 5.1.10.2.2 to capture a representation of the physical packet transmitted by the EUT;
 - 2) determine the position of bit p0 in the physical packet. If the bearer is not in slot pair 0 and 12 of the DECT frame, the position of bit p0 in slot 0 shall be calculated;
 - 3) at the same time, sample the synchronization pulse coming out of the EUT. The frame number in which the pulse is sampled shall be recorded;
- d) step c) shall be repeated for 50 frames;
- e) the LT shall calculate the widths of the synchronization pulses. The calculated widths shall be recorded along with the frame numbers;
- f) the LT shall calculate the time delay, T_d , between the falling edge of each synchronization pulse to bit p0 of slot 0 (calculated or measured) to that pulse's sampled RF packet;
- g) the synchronization port of the EUT shall be tested as specified in ITU-T Recommendation V.11 [9] clauses 5.2.1, 5.2.2 and 5.3.

5.3.9.2.1.2 Verdict criteria

The time delay T_d , pulse widths, and output port characteristics shall meet the following limits:

- a) the width of the synchronization pulse as measured shall be between 2 and 5 ms for frame 0 and between 5 μ s and 1 ms for all other frames;
- b) T_d as measured shall be 15 μ s \pm 5 μ s for class 1 FPs;
- c) T_d as measured shall be 15 μ s \pm 2 μ s for class 2 FPs;
- d) the synchronization port characteristics as measured in g) shall not exceed the limits stated in ITU-T Recommendation V.11 [9] clauses 5.2.1, 5.2.2 and 5.3.

The results obtained shall be compared to the limits in clause 4.5.9.2.1 in order to prove compliance with the requirement.

5.3.9.2.2 FP as a slave

5.3.9.2.2.1 Method of measurement

a) The EUT's synchronization input port shall be connected to the LT's output port.

b) A bearer shall be set-up between the LT and the EUT.

c) The LT shall:

- 1) generate a synchronization pulse in conformance with the limits specified for master FPs:

The synchronization signal is a 100 Hz signal having positive pulses of width between 5 μ s and 1 ms, except for frame 0 (every 16th pulse), which has a pulse width between 2 ms and 5 ms. This signal establishes the 10 ms DECT frame interval and the 160 ms DECT multiframe interval.

The synchronization signal shall have a long term frequency accuracy of better than ± 5 ppm (nominal conditions) or ± 10 ppm (extreme conditions).

As the wave form is asymmetric, devices can establish proper timing relations in the event that the differential pair of input signal wires is (improperly) connected (pair inversion).

The random phase jitter on the falling edge of the synchronization signal shall not exceed 0,5 μ s rms. The differential amplitude shall be greater than 400 mV peak to peak.

The synchronization port characteristics shall not exceed the limits stated in ITU-T Recommendation V.11 [9] clauses 5.2.1, 5.2.2 and 5.3.

The transition times of the synchronization pulse from the 10 % to 90 % points and from the 90 % to 10 % points shall not exceed 120 ns when measured into a 100 ohm ± 10 % load; 2) use the sampling method described in clause 5.1.10.2.2 to capture a representation of the physical packet transmitted by the EUT;

- 3) determine the position of bit p0 in the physical packet. If the bearer is not in slot pair 0 and 12 of the DECT frame, the position of bit p0 in slot 0 shall be calculated.

d) c) shall be repeated for 50 frames.

f) The LT shall calculate the time delay, T_d , between the falling edge of each synchronization pulse it generated to bit p0 of slot 0 (calculated or measured) to that pulse's sampled RF packet.

g) If the EUT is declared as being a class 2 FP, then the test laboratory shall verify that the time delay T_d can be set to 0 μ s, 15 μ s, and 20 μ s. The method of adjustment and the resolution are applicant specific and shall be declared to the test laboratory.

h) The input synchronization port of the EUT shall be tested as specified in ITU-T Recommendation V.11 [9] clauses 6.2, 6.3 and 6.4.

5.3.9.2.2.2 Verdict criteria

The time delay T_d as measured shall be within 15 μ s \pm 5 μ s for class 1 FPs; and within 15 μ s \pm 2 μ s for class 2 FPs.

The input port characteristics as measured shall not exceed the limits specified in ITU-T Recommendation V.11 [9] clauses 6.2, 6.3 and 6.4.

The results obtained shall be compared to the limits in clause 4.5.3.2.2 in order to prove compliance with the requirement.

5.3.9.3 GPS synchronization

5.3.9.3.1 FP with integrated Global Positioning System (GPS) synchronization

5.3.9.3.1.1 Method of measurement

This test is applicable if the FP is declared by the applicant to have integrated GPS synchronization:

- a) a bearer shall be set-up between the EUT and the LT;
- b) the LT shall:
 - 1) use the sampling method described in clause 5.1.10.2.2 to capture a representation of the physical packet transmitted by the EUT;
 - 2) determine the position of bit p0 in the physical packet. If the bearer is not in slot pair 0 and 12 of the DECT frame, the position of bit p0 in slot 0 shall be calculated. The frame number of the sampled packet shall be recorded;
 - 3) by means of its integrated GPS receiver generate a reference synchronization pulse. The falling edge of the frame 0 synchronization pulse shall coincide with $T_{\text{GPS}} \bmod 4 = 0$. (T_{GPS} is the GPS time);
- c) step b) shall be repeated 50 times;
- d) the LT shall calculate the time delay, T_d , between the falling edge of each reference synchronization pulse generated by the LT to bit p0 of slot 0 (calculated or measured) to that pulse's sampled RF packet.

5.3.9.3.1.2 Verdict criteria

The frame numbers and the time delay T_d shall meet the following limits:

The frame numbers shall conform to the GPS timing as described in 5.3.9.3.1.1 b) part 3).

- a) T_d as measured shall be $15 \mu\text{s} \pm 5 \mu\text{s}$ for class 1 FPs;
- b) T_d as measured shall be $15 \mu\text{s} \pm 2 \mu\text{s}$ for class 2 FPs;
- c) If the EUT at the same time is a master it shall also fulfill the requirements of clause 5.3.9.2.1.

The results obtained shall be compared to the limits in clause 4.5.9.3.1 in order to prove compliance with the requirement.

5.3.9.3.2 External GPS synchronization device

5.3.9.3.2.1 Method of measurement

- a) The EUT's synchronization port shall be connected to the LT's input port.
- b) The LT shall by means of its integrated GPS receiver generate a reference synchronization pulse related to the GPS timing as described in 5.3.9.3.1.1 b) part 3).
- c) The LT shall measure the time difference T_e between the falling edge of the pulse generated by the EUT and the falling edge of the reference pulse generated by the LT.
- d) The lower tester shall measure the width of the synchronization pulse generated by the EUT and at the same time record whether the reference synchronization pulse was a frame 0 pulse or not.
- e) Steps c) to d) shall be repeated 50 times.
- f) The synchronization port of the EUT shall be tested as specified in ITU-T Recommendation V.11 [9], clauses 5.2.1, 5.2.2 and 5.3.

5.3.9.3.2.2 Verdict criteria

The timing accuracy T_e , pulse widths, and output port characteristics shall meet the following limits:

- a) the timing accuracy T_e , as measured, shall be within $\pm 5 \mu\text{s}$ for class 1 FPs;
- b) the timing accuracy T_e , as measured, shall be within $\pm 2 \mu\text{s}$ for class 2 FPs;
- c) the width of the synchronization pulse as measured shall be between 2 and 5 ms for frame 0 and between $5 \mu\text{s}$ and 1 ms for all other frames;
- d) the synchronization port characteristics as measured in f) shall not exceed the limits stated in ITU-T Recommendation V.11 [9] clauses 5.2.1, 5.2.2 and 5.3.

The results obtained shall be compared to the limits in clause 4.5.9.3.2 in order to prove compliance with the requirement.

5.3.10 Equipment identity testing

There are no defined tests. Conformance to the requirements shall be shown by an applicant's declaration. See clause 4.5.10 of the present document.

5.3.11 Efficient use of the radio spectrum

There are no defined tests. Conformance to the requirements shall be shown by an applicant's declaration. See clause 4.5.11 of the present document.

5.3.12 WRS testing

5.3.12.1 General

The WRS EUT shall be tested as described below.

A WRS requires to be synchronized to a dummy bearer to derive its reference timer for PT and FT transmissions.

5.3.12.2 Testing as a PP

The WRS shall operate as a PP in the test-stand-by mode, TSM, annex C, as a stand alone module.

In this mode it shall be tested as a normal PP with the exception that RFP class E2 test conditions, see clause 5.1.13 of the present document, shall be used if it is intended for outdoor use, and that test case 19 is not applicable. See figure 40.

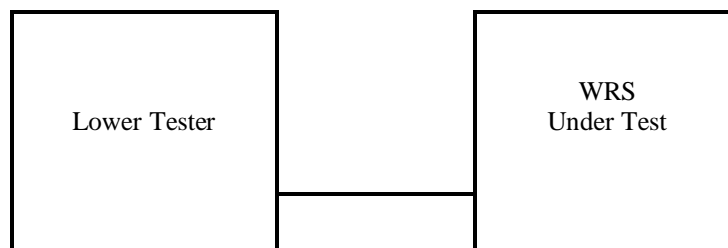

Figure 40: WRS testing as a PP

5.3.12.3 Testing as an RFP

A dummy bearer shall be generated by the Lower Tester or (if that is not possible) by an RFP supplied by the applicant and conforms to the present document. The WRS EUT shall be synchronized to the dummy bearer and shall operate as an RFP in test-stand-by Mode. The dummy bearer may change bearer during the test.

The EUT shall be tested as an RFP as regards the carrier frequency demands of clause 5.3.2 and reference timer accuracy demands of clause 5.3.3.2 of the present document. See figure 41.

NOTE: The power combiner is not needed if the PP and RFP functions have different antenna connectors.

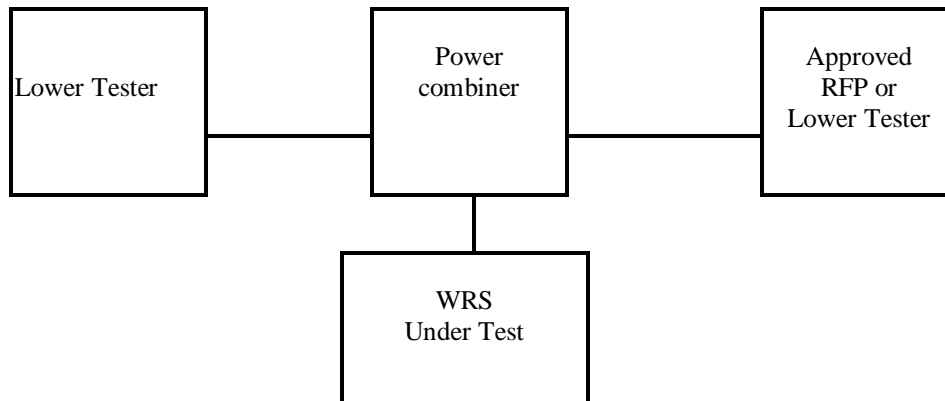

Figure 41: WRS testing as an RFP

5.3.12.4 Additional requirements

There are no defined tests for the additional requirements of clause 4.5.12.4 of the present document. Conformance to the requirements shall be shown by an applicant's declaration that:

- The WRS provides a mechanism to control the number of multihops, see EN 300 700 [10], clause 4.4.2.2.
- The WRS applies the defined frame multiplexing structure, see EN 300 700 [10] clauses 5.1.3.2 and 6.1.3.2.

Conformance to the requirements for a REP version of WRS shall be shown by an additional applicant's declaration that:

- The REP conforms to the requirements for channel selection of double duplex bearers, see EN 300 700 [10] clause 6.4.3.3.

5.3.13 Requirements for PPs with direct PP to PP communication mode

5.3.13.1 General

PPs or CTAs with direct communication mode option shall be tested for the PP requirements of the present document for normal non-direct communication with the amendments defined in the present clause.

5.3.13.2 Setting the EUT in direct communications mode

Entering and leaving the direct communications mode shall be made by manual keypad entries or by other means. The EUT shall be set in direct communications mode provided with proper identities. If class E identities are used, the requirements for class E identities in EN 300 175-6 [7], clauses 5.5, 6.1.5 and 6.3.2 shall be met.

When not processing a call, the EUT shall be in active unlocked PP state.

The applicant shall provide information about T1, typically 10 s, and T2 typically 20 s.

5.3.13.3 When the EUT has not initiated a call

When the EUT has not initiated a call, it shall meet the "non-direct mode" PP requirements of the present document, but with the following amendments:

- a) The EUT shall in the active unlocked PP state scan all channels on relevant carriers at least every T1 s.

- b) If ARI class E is used, the paged EUT is allowed to make the bearer setup attempt only on the channel pair where the initiating PP transmits.

5.3.13.4 When the EUT initiates a call

By initiating a call means that the number of the wanted subscriber is entered via the keypad or by other means, and that the EUT at "off-hook command" shall enter the RFP active idle state. See EN 300 175-3 [5], clause 4.3.

When the EUT initiates a call, it shall meet the "non-direct mode" RFP requirements of the present document, but with the following amendments:

- a) the 25 ppm PP timer stability requirements apply. See EN 300 175-2 [4] clause 4.2.2;
- b) an EUT entering RFP mode is allowed to derive over the air frame and slot synchronization from a DECT system having "non-class E" identities;
- c) the EUT shall use FP or PP simplex bearer channel selection rules for the RFP active idle state. See EN 300 175-3 [5], clause 11.4;
- d) the page message shall be transmitted in every multiframe as long as in active idle state;
- e) the short page format shall be used for ARI class E;
- f) the EUT shall revert from active idle RFP state to PP active unlocked state, if a duplex bearer has not been established within $T_2 > T_1$ s;
- g) the PP is not required to do receiver scanning for ARI class E in RFP active idle nor active state. See EN 300 175-3 [5], clause 11.8, and EN 300 175-6 [6], clause 5.5;
- h) if identities class E are used, the N_T message will not contain an ETSI distributed code. See clause 4.5.10.2 of the present document.

5.3.13.5 Applicants declarations

The applicant shall declare:

- that equipment using class E identities conform to the requirements of EN 300 175-6 [7], clauses 5.5, 6.1.5 and 6.3.2.
- conformance to other requirements of clause 5.3.13 for which test tool are not available.

5.3.14 Distributed Communications

5.3.14.1 General

PPs and CTAs with distributed communications option, HyPs, shall be tested as a stand alone PP and shall comply to all relevant PP test cases in the present document. In addition the HyPs shall be tested as an RFP as regards the carrier frequency demands of clause 4.5.2 and reference timer accuracy demands of clause 4.5.3.4 of this the present document.

The HyP EUT shall meet the PT and FT requirements and the applicants declarations as described below.

A HyP requires to be synchronized to a bearer to derive its reference timer for PT and FT transmissions.

5.3.14.2 Testing as a PP

The EUT shall operate as a PP in the test-stand-by mode, TSM, see annex C, as a stand alone module.

In this mode it shall be tested as a normal PP. See figure 42.

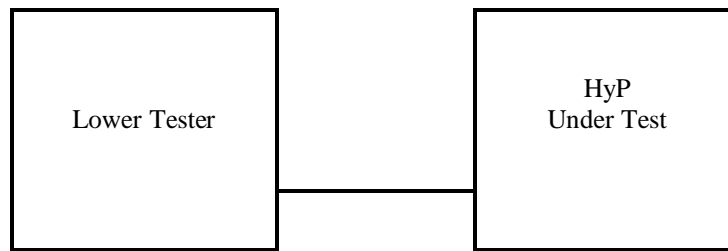

Figure 42: HyP testing as a PP

5.3.14.3 Testing as an RFP

A dummy bearer shall be generated by the Lower Tester or (if that is not possible) by an RFP supplied by the applicant and conforms to the present document. The EUT shall be synchronized to the dummy bearer and shall operate as an RFP in test-stand-by Mode. The dummy bearer may change bearer during the test.

The EUT shall tested as an RFP as regards the carrier frequency demands of clause 5.3.1 and reference timer accuracy demands of clause 5.3.3.2 of the present document. See figure 43.

NOTE: The power combiner is not needed if the PP and RFP functions have different antenna connectors.

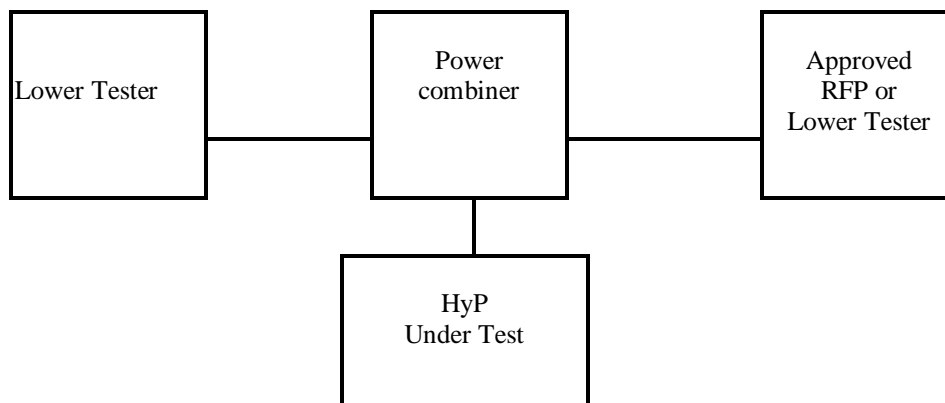

Figure 43: HyP testing as an RFP

5.3.14.4 Applicants declaration

The applicant shall declare conformance to requirements of clause 5.3.14 for which test tool are not available.

5.3.15 Higher level modulation options

5.3.15.1 General

The 4-level modulation shall be $\pi/4$ -DQPSK and the 8-level modulation $\pi/8$ -D8PSK (see EN 300 175-2 [4] annex D). It is only allowed to use 4-level and/or 8-level modulation in the B + Z or the A + B + Z fields, see EN 300 175-2 [4] clause 4.8 and EN 300 175-3 [5] clause 6.2.1.1, whereby the S + A or the S field respectively shall use the $\pi/2$ -DBPSK 2-level modulation as defined in EN 300 175-2 [4] annex D. The different configurations, 1a to 4b, for allowed combinations of modulation schemes are defined in table 27.

Table 27: Configurations of allowed combinations of modulation types in the S-,A and (B+Z)-fields

Configuration	S-field	A-field	B + Z-field
1a	GFSK	GFSK	GFSK
1b	$\pi/2$ -DBPSK	$\pi/2$ -DBPSK	$\pi/2$ -DBPSK
2	$\pi/2$ -DBPSK	$\pi/2$ -DBPSK	$\pi/4$ -DQPSK
3	$\pi/2$ -DBPSK	$\pi/2$ -DBPSK	$\pi/8$ -D8PSK
4a	$\pi/2$ -DBPSK	$\pi/4$ -DQPSK	$\pi/4$ -DQPSK
4b	$\pi/2$ -DBPSK	$\pi/8$ -D8PSK	$\pi/8$ -D8PSK

Configuration 1a is the basic DECT modulation scheme for which all tests in the present document are defined.

Equipment that is capable of operating in any of the configurations 2 - 4 shall also be able to operate in configuration 1 (1a or 1b).

Such equipment shall in configuration 1a be tested to conform to all requirements of the present document that apply for equipment using the basic 1a configuration.

Such equipment that does not support configuration 1a, shall in configuration 1b be tested conform to all requirements (verdict criteria) of the present document that apply for equipment using the basic 1a configuration, with the exception for clause 5.3.6 "RF carrier modulation" and with the exception for the verdict criteria clauses 4.5.4.1.6 ("Minimum power") and 4.5.4.1.7 ("Maximum power") of clause 5.3.4.3.

Additionally, if the EUT includes a radio transmitter capable of 4-level and/or 8-level modulation, the ETU shall be tested to conform to the requirements of clauses 5.3.5 and 5.3.7 of the present document using the 4-level and/or 8-level modulation in the B + Z or A + B + Z fields.

5.3.15.2 Activation of higher level modulations when EUT is in test stand-by mode

The applicant shall supply a method, to be applied when the EUT is in test stand-by mode, by which the EUT supporting 4/8-level modulation might activate such options. If both options are supported, It shall be possible to select 4-level and 8-level modulation independently each other.

Such a method may be controlled either by some means of manual switching (e.g. dip-switch, jumper, prom, or key-pad code as designated by the applicant), or by means of the CHANGE_MODULATION_SCHEME test message, if agreed with the test house. If only one type of higher level modulation is supported, the method may consist of activating this higher level modulation option at the expiring of a pre-defined timer started after the bearer setup.

The applicant shall describe this method in the PIXIT.

For the purpose of testing (especially when in test stand-by mode) the EUT shall always use 2-level modulation in the A-field.

5.3.15.3 Applicants declaration

The applicant shall declare conformance to requirements of clause 5.3.15 for which test tools are not available.

The applicant shall for RF carrier modulation and power template declare conformance to the standard EN 300 175-2 [4] annex D 4-level and/or 8-level.

Annex A (normative): The EN Requirements Table (EN-RT)

Notwithstanding the provisions of the copyright clause related to the text of the present document, ETSI grants that users of the present document may freely reproduce the EN-RT proforma in this annex so that it can be used for its intended purposes and may further publish the completed EN-RT.

The EN Requirements Table (EN-RT) serves a number of purposes, as follows:

- it provides a tabular summary of all the requirements;
- it shows the status of each EN-R, whether it is essential to implement in all circumstances (Mandatory), or whether the requirement is dependent on the supplier having chosen to support a particular optional service or functionality (Optional). In particular it enables the EN-Rs associated with a particular optional service or functionality to be grouped and identified;
- when completed in respect of a particular equipment it provides a means to undertake the static assessment of conformity with the EN.

Table A.1: EN Requirements Table (EN-RT)

EN Reference		EN <xxx xxx>				Comment
Test Case No.	Clause / Clause Number	EN-R (note)	Status			
1	4.5.2	Accuracy and stability of RF carriers	M			
2	4.5.3	Timing jitter: slot-slot on the same channel	M			
3	4.5.3	Reference timing accuracy of a RFP	M			
4	4.5.3	Measurement of packet timing accuracy	M			
5	4.5.4	Transmission Burst	M			
6	4.5.5.1.2	Transmitted power: PP and RFP with an integral antenna	O			
7	4.5.5.1.3	Transmitted power: PP and RFP with an external antenna connector	O			
8	4.5.6	RF carrier modulation	M			
9	4.5.7.2	Emissions due to modulation	M			
10	4.5.7.3	Emissions due to transmitter transients	M			
11	4.5.7.4	Emissions due to intermodulation	M			
12	4.5.7.5	Spurious emissions when allocated a transmit channel	M			
13	4.5.8.1	Radio receiver sensitivity	M			
14	4.5.8.2	Radio receiver bit error ratio	M			
15	4.5.8.3	Radio receiver interference performance	M			
16	4.5.8.4	Radio receiver blocking case 1	M			
17	4.5.8.5	Radio receiver blocking case 2	M			
18	4.5.8.6	Receiver intermodulation performance	M			
19	4.5.8.7	Spurious emissions when the radio endpoint has no allocated transmit channel	M			
20	4.5.9	Synchronization port	O			
21	4.5.10	Equipment identity verification/safeguards	M			
22	4.5.11	Efficient use of radio spectrum	M			
23	4.5.12	WRS	O			
24	4.5.13	PP to PP communication	O			
25	4.5.14	Direct communication	O			
26	4.5.15	Higher level modulation	O			

NOTE: These EN-Rs are justified under article 3.2 of the R&TTE Directive.

Key to columns:**No** Table entry number;**Reference** Clause reference number of conformance requirement within the present document;**EN-R** Title of conformance requirement within the present document;**Status** Status of the entry as follows:

M Mandatory, shall be implemented under all circumstances;

O Optional, may be provided, but if provided shall be implemented in accordance with the requirements;

O.n this status is used for mutually exclusive or selectable options among a set. The integer "n" shall refer to a unique group of options within the EN-RT. A footnote to the EN-RT shall explicitly state what the requirement is for each numbered group. For example, "It is mandatory to support at least one of these options", or, "It is mandatory to support exactly one of these options".

Comments To be completed as required.

Annex B (normative): Procedures for test fixture calibration

B.1 Calibration of test fixture for receiver measurements

B.1.1 Procedure

The calibration procedure utilizes the average measured usable sensitivity of the receiver. The average measured usable sensitivity expressed as field strength for bit stream shall be the average of eight measurements of field strength, expressed in dB μ V/m, at the nominal frequency of the receiver and with specified test modulation which produces after demodulation a data signal with a bit error ratio of 10^{-3} , when the receiver is rotated in 45° increments, starting at the reference orientation.

B.1.2 Method of measurement

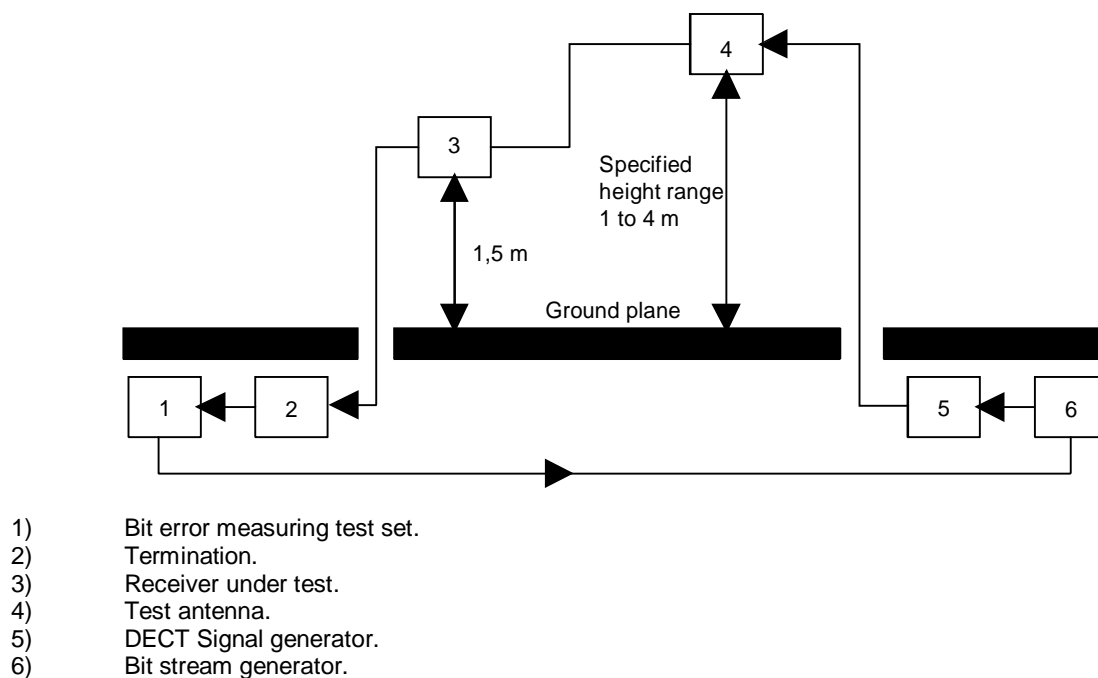

Figure B.1: Measurement arrangement No.1

- a) A test site which fulfills the requirements of the specified frequency range of this measurement shall be used. The test antenna shall be oriented initially for vertical polarization unless otherwise stated.

A signal generator capable of producing a DECT signal shall be connected to the test antenna. The signal generator shall be at the nominal frequency of the receiver and shall be modulated by the test modulation D-M2. The receiver under test shall be placed on the support in its standard position and oriented so that a face, specified by the applicant, is normal to the direction of the test antenna. This is the reference orientation for the measurement.

- b) The bit pattern of the modulating signal shall be compared to the bit pattern obtained from the receiver after demodulation.
- c) The output level of the signal generator shall be adjusted until a bit error ratio of 10^{-3} is obtained.
- d) The test antenna shall be raised or lowered again through the specified height range to find the lowest level of the test signal which produces the same bit error ratio.

- e) Record the minimum signal generator level from c) or d).
- f) Steps b) to e) shall be repeated for the eight positions 45° apart of the receiver and the corresponding values of the generator output which produces the same bit error ratio will be determined and recorded.
- g) Using the calibration of the test site, calculate the eight field strengths X_i ($\mu\text{V}/\text{m}$) corresponding to the output level above of the signal generator. The average measured usable sensitivity expressed as field strength X_{mean} ($\text{dB}\mu\text{V}/\text{m}$) is given by:

$$X_{\text{mean}} = 20 \log \left[\frac{8}{\sum_{i=1}^{i=8} \left(\frac{1}{X_i^2} \right)} \right]^{1/2}$$

- h) Measurements b) to g) shall be repeated with the test antenna oriented in horizontal polarization.
- i) Record the lower value of the two recorded in steps g) and h) above.
- j) Using the test fixture in measuring arrangement No.2 the measurement may also be performed under extreme test conditions.

Additional uncertainties can occur under extreme test conditions due to the calibration of the test fixture.

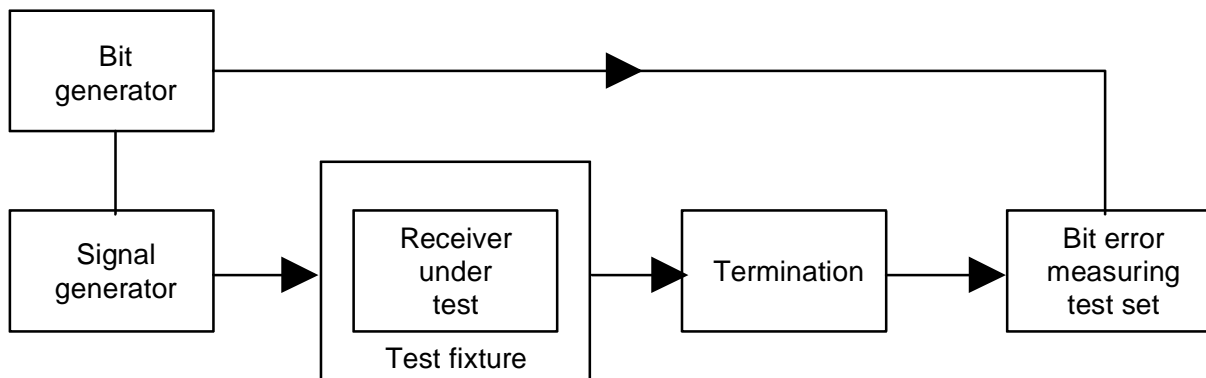

Figure B.2: Measurement arrangement No.2

- k) The test signal input level providing a BER of 10^{-3} shall be determined under normal and extreme test conditions and the difference in dB is noted. This difference shall be algebraically added to the average measured usable sensitivity to radiated fields for bit stream expressed in $\text{dB}\mu\text{V}/\text{m}$ under normal test conditions, to obtain the same quantity under extreme test conditions.

Annex C (normative): Test Support Profile (TSP)

C.1 Introduction

This annex defines the provisions of the TSP for DECT equipment (EUT) capabilities in Test Standby Mode (TSM) and for the Lower Tester (LT) capabilities while performing the tests described in the present document. When there exists a reference to "TSM" in the present document, it shall be applied for both the test standby mode and the test mode(s) in operation as described in EN 300 175-3 [5], clause 12.2.

It specifies three different bearer setup procedures, as described in EN 300 175-3 [5], clauses 10.5.1.1, 10.5.1.2 and 10.5.1.3 in order to transfer test messages described in EN 300 175-3 [5] clause 12 and clause 7.2.5.4. One of these 3 bearer setup procedures shall be supported by the LT and EUT.

C.2 Standardized symbols for the status column

The standardized symbols for the status column are as follows:

- M for always mandatory (the capability is required to be implemented). M1, M2, M3 for mandatory in respective order for basic bearer setup, A-field advanced single bearer setup and B-field single bearer setup procedures supported (if bearer setup type n is not supported then Mn shall be understood to mean O);
- O for optional (Boolean) (the capability may be implemented, but can be ignored on receipt);
- X for prohibited or excluded (the capability is not allowed to be implemented);
- I for out of scope in the test standby mode (the capability is allowed to be implemented, but is irrelevant in the test standby mode);
- - (dash) for not applicable (the capability is not possible to implement);
- C for conditional (the capability depends on the selection of other optional and/or conditional items). C1, C2, C3 for conditional in respective order for basic bearer setup, A-field advanced single bearer setup and B-field single bearer setup procedures supported (if bearer setup type n is not supported then Cn shall be understood to mean O).

All other capabilities not shown in this annex shall be regarded as optional or out of scope. Tables D.1 and D.2 show the interpretation of these symbols in this annex.

Table C.1: Usage of symbols

Symbols \ Usage	Allowed to be implemented in the EUT	Possible in normal operation (EN 300 175)	Possible in TSM (this standard)	Out of scope of TSM
M	Yes	Yes	Yes	No
O	Yes	Yes	Yes	No
I	Yes	Yes	No	Yes
-	No	No	No	Yes
X	Yes	Yes	No	Yes

Table C.2: Symbols and their relation to transmit and receive events

Symbols \ TX, RX	Transmit	Receive
M	shall process and send	if received; shall process
O	allowed to be sent	if received; optionally processed
I	not possible to send (in TSM)	not possible to receive (in TSM)
-	not possible ever	not possible ever
X	not allowed to be sent in TSM	if received: not allowed to be processed in TSM

C.3 Capabilities of PP (EUT) under test

C.3.1 Services

Table C.3: Broadcast services

Broadcast services supported				
Item No.	Name of service	Reference	PT Status	LT Status
1	Continuous broadcast	5.7.1.1	M	M
2	System identities	11.3.2	O	M
3	System information	11.3.2	M	M

C.3.2 Messages

Table C.4: Header-field messages

Header-field messages						
Item No.	Message	Reference	Sending		Receipt	
			PT Status	LT Status	PT Status	LT Status
4	Identities information	7.1.2	M	M	O	O
5	Multiframe synchronization and system information	7.1.2	-	M	M	-
6	Escape	7.1.2	O	X	I	X
7	MAC layer control	7.1.2	M	M	M	M
9	First PP transmission	7.1.2	M	-	-	O
12	U-type, I _N , S _N or I _P packet number 0,1	7.1.4	M	M	M	M
16	E-type, not all C _F or CL _F ; packet number 0	7.1.4	C3	X	I	M3
17	E-type, not all C _F ; C _F packet number 1	7.1.4	C3	X	I	M3
18	E-type, all MAC control (unnumbered)	7.1.4	C3	M3	M3	M3
19	No B-field	7.1.4	O	O	O	O

NOTE: C3 at least one of the set is mandatory for the EUT.

Table C.5: Messages in the A-tail field

Messages in the A-tail field						
Item No.	Message	Reference	Sending		Receipt	
			PT Status	LT Status	PT Status	LT Status
1	Identities information	7.2.2	O	M	O	O
2	Static system information	7.2.3.2	-	M	M	-
3	Extended RF carrier information	7.2.3.3	-	X	I	-
4	Fixed part capabilities	7.2.3.4	-	M	O	-
8	Q-channel escape	7.2.3.8	-	X	I	-
31	Basic CC access request	7.2.5.2.2	M1	-	-	M1
32	Basic CC bearer handover request	7.2.5.2.2	O	-	-	M1
33	Basic CC connection handover request	7.2.5.2.2	O	-	-	M1
35	Basic CC bearer confirm	7.2.5.2.2	-	M1	O	-
36	Basic CC bearer release	7.2.5.2.2	O	X	I	M1
37	Basic CC wait	7.2.5.2.3	-	X	I	-
38	Advanced CC access request	7.2.5.3.2	M2	X	I	M2
39	Advanced CC bearer handover request	7.2.5.3.3	O	X	I	M2
40	Advanced CC connection handover request	7.2.5.3.4	O	X	I	M2
41	Advanced CC unconfirmed access request	7.2.5.3.5	O	X	I	O
42	Advanced CC bearer confirm	7.2.5.3.6	O	M2	M2	O
43	Advanced CC wait	7.2.5.3.7	O	M2	O	M2
44	Advanced CC attributes_T, request	7.2.5.3.8	M2	X	I	M2
45	Advanced CC attributes_T, confirm	7.2.5.3.8	O	M2	O	O
46	Advanced CC bandwidth_T, request	7.2.5.3.9	O	X	I	O
47	Advanced CC bandwidth_T, confirm	7.2.5.3.9	O	O	O	O
51	Advanced CC release	7.2.5.3.13	O	X	I	M2
52	MAC test force transmit	7.2.5.4.2	-	M	M	-
53	MAC test loopback data	7.2.5.4.3	-	M	M	-
54	MAC test defeat antenna diversity	7.2.5.4.4	-	M	M	-
55	MAC test force bearer handover	7.2.5.4.5	-	I	I	-
56	MAC test escape	7.2.5.4.6	X	X	I	I
58	MAC test clear test modes	7.2.5.4.8	-	M	M	-
82	B-field setup, first PT transmission	7.2.5.8	O	-	-	M3
83	MAC control escape	7.2.5.9	O	X	I	O

Table C.6: Messages in the B-tail field

Messages in the B-tail field						
Item No.	Message	Reference	Sending		Receipt	
			PT Status	LT Status	PT Status	LT Status
1	Advanced CC access request	7.3.3.2	M3	X	I	M3
2	Advanced CC bearer handover request	7.3.3.2	O	X	I	M3
3	Advanced CC connection handover request	7.3.3.2	O	X	I	M3
4	Advanced CC unconfirmed access request	7.3.3.2	O	X	I	O
5	Advanced CC bearer confirm	7.3.3.3	O	M3	M3	O
6	Advanced CC wait	7.3.3.4	O	X	O	O
9	B-field bandwidth-B request	7.3.3.6	O	X	O	O
14	Advanced CC release	7.3.3.10	O	X	O	M3
30	B-field escape	7.3.8	O	X	I	X

C.3.3 Message parameters

The slot type shall be set correctly in all message parameters.

The equipment supplier shall provide message parameter details for configuring the LT.

Table C.7: Parameters for A-field static system information message

Parameters for A-field static system information message						
Item No.	Name of Parameter	Reference	PT Status	LT Status	Values	
					PT Allowed	LT Allowed
1	Normal-reverse	7.2.3.2.2	M	M	0,1	0
2	Slot number	7.2.3.2.3	M	M	0-11	0-11
3	Start position	7.2.3.2.4	M	M	0,2	0,2
4	Q_T escape bit	7.2.3.2.5	M	M	0,1	0,1
5	Number of transceivers	7.2.3.2.6	O	M	0-3	0
6	Extended RF carrier information available	7.2.3.2.7	O	M	0,1	0
7	RF carriers available	7.2.3.2.8	O	M	1-1023	1-1023
8	Carrier number	7.2.3.2.10	O	M	0-9	0-9
9	Primary receiver scan carrier number	7.2.3.2.12	O	M	0-9	0-9

Table C.8: Parameters for MAC FP capability message

Parameters for A-field MAC FP capability message						
Item No.	Name of parameter	Reference	PT Status	LT Status	Values	
					PT Allowed	LT Allowed
1	Extended FP information	7.2.3.4.2	O	M	0,1	0
2	Double slot	7.2.3.4.2	O	M	0,1	0,1
3	Half slot	7.2.3.4.2	O	M	0,1	0,1
4	Full slot	7.2.3.4.2	O	M	0,1	0
5	Frequency control	7.2.3.4.2	O	M	0,1	0
6	Page repetition	7.2.3.4.2	O	M	0,1	0
7	C/O setup on dummy bearer allowed	7.2.3.4.2	O	M	0,1	0
8	C/L uplink	7.2.3.4.2	O	M	0,1	0
9	C/L downlink	7.2.3.4.2	O	M	0,1	0
10	Basic A-field setup	7.2.3.4.2	O	M	0,1	0,1
11	Advanced A-field setup	7.2.3.4.2	O	M	0,1	0,1
12	B-field setup	7.2.3.4.2	O	M	0,1	0,1
13	C_F messages	7.2.3.4.2	O	M	0,1	0,1
14	I_N minimum delay	7.2.3.4.2	O	M	0,1	0
15	I_N normal delay	7.2.3.4.2	O	M	0,1	0,1
16	I_P error detection	7.2.3.4.2	O	M	0,1	0,1
17	I_P error correction	7.2.3.4.2	O	M	0,1	0,1
18	Multibearer connections	7.2.3.4.2	O	M	0,1	0,1

**Table C.9: Parameters for higher layer information FP capability message
(EN 300 175-5 [6], annex F)**

Parameters for A-field higher layer information FP capability message						
Item No.	Name of parameter	Reference	PT Status	LT Status	Values	
					PT Allowed	LT Allowed
1	ADPCM/G.726 [14] Voice service	a32	O	M	0,1	0,1
2	Generic Access Profile (GAP) supported	a33	O	M	0,1	0,1
3	Non-voice circuit switched service	a34	O	M	0,1	0,1
4	Non-voice packet switched service	a35	O	M	0,1	0,1
5	Standard authentication required	a36	O	M	0,1	0,1
6	Standard ciphering supported	a37	I	M	0,1	0
7	Location registration supported	a38	O	M	0,1	0,1
8	SIM services available	a39	O	M	0,1	0,1
9	Non-static Fixed Part (FP)	a40	O	M	0,1	0,1
10	CISS services available	a41	O	M	0,1	0,1
11	CLMS services available	a42	O	M	0,1	0,1
12	COMS services available	a43	O	M	0,1	0,1
13	Access rights requests supported	a44	O	M	0,1	0,1
14	External handover supported	a45	O	M	0,1	0,1
15	Connection handover supported	a46	O	M	0,1	0,1
16	Reserved	a47	O	M	0,1	0,1

NOTE: G.726: ITU-T Recommendation G.726 [14].

C.3.4 Procedure support

Table C.10: Procedures supported

Procedure supported				
Item No.	Name of Procedure	Reference	PT Status	LT Status
1	Downlink continuous broadcast	9.1.1	M	M
21a	Basic bearer setup	10.5.1.1	M1	M1
22	A-field advanced single bearer setup	10.5.1.3	M2	M2
23	B-field single bearer setup	10.5.1.3	M3	M3
27	Duplex bearer handover procedure	10.6.2	O	M
29	Unacknowledged bearer release	10.7.2.1	O	M
36	Idle lock state entering procedure	10.6.2	O	X
37	Idle lock state maintaining procedure	10.6.2	O	X
40	Duplex bearer physical channel selection	11.4.1	X	-
41	Double simplex bearer physical channel selection	11.4.1	X	-
45a	RFP idle receiver scan sequence	11.8	O	M
45b	PP fast setup receiver scan sequence	11.9	O	X
46	Test message	12.2	M	M

C.3.5 CSF multiplexing functions

Table C.11: CSF multiplexing functions

CSF multiplexing functions				
Item No.	Name of function	Reference	PT Status	LT Status
1	D-field MAP D80	6.2.1.1	Ca	Cb
2	D-field MAP D32	6.2.1.1	Ca	Cb
3	D-field MAP D08	6.2.1.1	Ca	Cb
4	D-field MAP D00	6.2.1.1	Ca	Cb
5	A-field MAP	6.2.1.2	M	M
6	B-field MAP D80 unprotected	6.2.1.3	Cc	Cd
7	B-field MAP D32 unprotected	6.2.1.3	Cc	Cd
8	B-field MAP D08 unprotected	6.2.1.3	Cc	Cd
9	B-field MAP D80 protected	6.2.1.3	Cc	Cd
10	B-field MAP D32 protected	6.2.1.3	Cc	Cd
11	B-field MAP D08 protected	6.2.1.3	Cc	Cd
12	Tail multiplexer	6.2.2.1	M	M
13	E/U-mux E80	6.2.2.2	Ce	Cf
14	E/U-mux E32	6.2.2.2	Ce	Cf
15	E/U-mux E08	6.2.2.2	Ce	Cf
16	E/U-mux U80a	6.2.2.2	Ce	Cf
17	E/U-mux U32a	6.2.2.2	Ce	Cf
18	E/U-mux U08a	6.2.2.2	Ce	Cf
19	E/U-mux U80b	6.2.2.2	Ce	Cf
20	E/U-mux U32b	6.2.2.2	Ce	Cf
21	E/U-mux U08b	6.2.2.2	Ce	Cf
32	C-mux Double Slot mode 10	6.2.2.3.1	C3g	C3g
37	C-mux Full Slot mode 4	6.2.2.3.1	C3h	C3h
39	C-mux Half Slot mode 1	6.2.2.3.2	C3i	C3i
40	Encryption	6.2.3	O	O
41	Scrambling	6.2.4	M3	M3
42a	A-field R-CRC generation	6.2.5.2	M	M
42b	B-field R-CRC generation	6.2.5.2	M3	M3
43a	A field R-CRC checking	6.2.5.2	M	M
43a	B-field R-CRC checking	6.2.5.2	M3	M3
44	X-CRC generation	6.2.5.4	M	M
45	X-CRC checking	6.2.5.4	M	O
46	Broadcast control function	6.2.6	-	M

NOTE 1: For A-field setups (i.e. type 1 and 2): only A-field R-CRC is mandatory.
NOTE 2: Ca: at least one shall be supported by the EUT.
NOTE 3: Cb: at least one shall be supported by the LT.
NOTE 4: Cc: at least one shall be supported by the EUT.
NOTE 5: Cd: at least one shall be supported by the LT.
NOTE 6: Ce: at least one shall be supported by the EUT.
NOTE 7: Cf: at least one shall be supported by the LT.
NOTE 8: C3g: mandatory if double slot supported.
NOTE 9: C3h: mandatory if full slot supported.
NOTE 10: C3i: mandatory if half slot supported.

C.3.6 Timer and counter support

Those timers and counters required by the mandatory procedures are classified as mandatory (see table D.10).

C.4 Capabilities of FP (EUT) under test

C.4.1 Services

Table C.12: Broadcast services

Broadcast services supported				
Item No.	Name of service	Reference	FT Status	LT Status
1	Continuous broadcast	5.7.1.1	M	M
2	System identities	5.7.1.1	O	M
3	System information	5.7.1.1	M	M

C.4.2 Messages

Table C.13: Header field messages

Header-field messages						
Item No.	Message	Reference	Sending		Receipt	
			FT Status	LT Status	FT Status	LT Status
3	Identities information on C/L bearer	7.1.2	O	-	-	M
4	Identities information	7.1.2	M	M	M	M
5	Multiframe synchronization and system information	7.1.2	M	-	-	M
6	Escape	7.1.2	X	X	I	-
7	MAC layer control	7.1.2	M	M	M	M
9	First PP transmission	7.1.2	-	M	M	-
12	U-type, IN, SIN or IP packet number 0	7.1.4	M	M	M	M
16	E-type, not all CF or CLF; packet number 0	7.1.4	C3	M3	C3	M3
17	E-type, not all CF; CF packet number 1	7.1.4	C3	M3	C3	M3
18	E-type, all MAC control (unnumbered)	7.1.4	C3	M3	C3	M3
19	No B-field	7.1.4	O	O	O	M

NOTE: C3:at least one of the set is mandatory for the EUT.

Table C.14: Messages in the A-tail field

Messages in the A-tail field						
Item No.	Message	Reference	Sending		Receipt	
			FT Status	LT Status	FT Status	LT Status
1	Identities information	7.2.2	O	M	O	M
2	Static system information	7.2.3.2	M	-	-	M
3	Extended RF carrier information	7.2.3.3	X	-	-	I
4	Fixed part capabilities	7.2.3.4	O	-	-	M
8	Q-channel escape	7.2.3.8	O	-	-	X
31	Basic CC access request	7.2.5.2.2	-	M1	M1	-
32	Basic CC bearer handover request	7.2.5.2.2	-	X	I	-
33	Basic CC connection handover request	7.2.5.2.2	-	X	I	-
34	Basic CC unconfirmed access request	7.2.5.2.2	-	X	I	-
35	Basic CC bearer confirm	7.2.5.2.2	M1	-	-	M1
36	Basic CC bearer release	7.2.5.2.2	O	M1	M1	M1
37	Basic CC wait	7.2.5.2.3	O	M1	O	M1
38	Advanced CC access request	7.2.5.3.2	O	M2	M2	O
39	Advanced CC bearer handover request	7.2.5.3.3	-	X	I	-
40	Advanced CC connection handover request	7.2.5.3.4	O	X	I	O
41	Advanced CC unconfirmed access request	7.2.5.3.5	O	X	I	O
42	Advanced CC bearer confirm	7.2.5.3.6	M2	O	O	M2
43	Advanced CC wait	7.2.5.3.7	O	M2	O	M2
44	Advanced CC attributes_T, request	7.2.5.3.8	O	M2	M2	O
45	Advanced CC attributes_T, confirm	7.2.5.3.8	M2	O	O	M2
46	Advanced CC bandwidth_T, request	7.2.5.3.9	O	X	O	O
51	Advanced CC release	7.2.5.3.13	O	M2	M2	M2
52	MAC test force transmit	7.2.5.4.2	-	X	-	-
53	MAC test loopback data	7.2.5.4.3	-	M	M	-
54	MAC test defeat antenna diversity	7.2.5.4.4	-	M	M	-
55	MAC test force bearer handover	7.2.5.4.5	X	X	I	I
56	MAC test escape	7.2.5.4.6	X	X	I	I
57	MAC test network test	7.2.5.4.7	X	I	I	I
58	MAC test clear test modes	7.2.5.4.8	-	M	M	-
79	Encryption request	7.2.5.7	-	O	O	-
80	Encryption confirm	7.2.5.7	O	-	-	O
81	Encryption grant	7.2.5.7	-	O	O	-
82	B-field setup, first PT transmission	7.2.5.8	-	M3	M3	-
83	MAC control escape	7.2.5.9	O	X	I	O

Table C.15: Messages in the B-tail field

Messages in the B-tail field						
Item No.	Message	Reference	Sending		Receipt	
			FT Status	LT Status	FT Status	LT Status
1	Advanced CC access request	7.3.3.2	O	M3	M3	O
2	Advanced CC bearer handover request	7.3.3.2	-	X	O	-
3	Advanced CC connection handover request	7.3.3.2	O	X	O	O
4	Advanced CC unconfirmed access request	7.3.3.2	O	X	O	O
5	Advanced CC bearer confirm	7.3.3.3	M3	O	O	M3
6	Advanced CC wait	7.3.3.4	O	M3	O	M3
14	Advanced CC release	7.3.3.10	O	M3	M3	M3
30	B-field escape	7.3.8	O	X	I	X

C.4.3 Message parameters

The slot type shall be set correctly in all message parameters.

The equipment supplier shall provide message parameter details for configuring the LT.

Table C.16: Parameters for A-field static system information message

Parameters for A-field static system information message						
Item No.	Name of parameter	Reference	FT Status	LT Status	Values	
					FT Allowed	LT Allowed
1	Normal-reverse	7.2.3.2.2	M	M	0,1	0,1
2	Slot number	7.2.3.2.3	M	M	0-11	0-11
3	Start position	7.2.3.2.4	M	M	0,2	0,2
4	QT escape bit	7.2.3.2.5	M	M	0,1	0,1
5	Number of transceivers	7.2.3.2.6	M	M	0-3	0-3
6	Extended RF carrier information available	7.2.3.2.7	M	M	0,1	0,1
7	RF carriers available	7.2.3.2.8	M	M	1-1023	1-1023
8	Carrier number	7.2.3.2.10	M	M	0-9	0-9
9	Primary receiver scan carrier number	7.2.3.2.12	M	M	0-9	0-9

NOTE: Slot number, carrier number and primary receive scan carrier number shall be dynamically set by the EUT.

Table C.17: Parameters for MAC FP capability message

Parameters for A-field MAC FP capability message						
Item No.	Name of parameter	Reference	FT Status	LT Status	Values	
					FT Allowed	LT Allowed
1	Extended Fixed Part information	7.2.3.4.2	O	M	0,1	0
2	Double slot	7.2.3.4.2	O	M	0,1	0,1
3	Half slot	7.2.3.4.2	O	M	0,1	0,1
4	Full slot	7.2.3.4.2	O	M	0,1	0
5	Frequency control	7.2.3.4.2	O	M	0,1	0
6	Page repetition	7.2.3.4.2	O	M	0,1	0
7	C/O setup on dummy bearer allowed	7.2.3.4.2	O	M	0,1	0
8	C/L uplink	7.2.3.4.2	O	M	0,1	0
9	C/L downlink	7.2.3.4.2	O	M	0,1	0
10	Basic A-field setup	7.2.3.4.2	O	M1	0,1	0,1
11	Advanced A-field setup	7.2.3.4.2	O	M2	0,1	0,1
12	B-field setup	7.2.3.4.2	O	M3	0,1	0,1
13	CF messages	7.2.3.4.2	O	M	0,1	0,1
14	IN minimum delay	7.2.3.4.2	O	M	0,1	0
15	IN normal delay	7.2.3.4.2	O	M	0,1	0,1
16	IP error detection	7.2.3.4.2	O	M	0,1	0,1
17	IP error correction	7.2.3.4.2	O	M	0,1	0,1
18	Multibearer connections	7.2.3.4.2	O	M	0,1	0,1

**Table C.18: Parameters for higher layer information FP capability message
(EN 300 175-5 [6], annex F)**

Parameters for A-field higher layer information FP capability message						
Item No.	Name of Parameter	Reference	FT Status	LT Status	Values	
					FT Allowed	LT Allowed
1	ADPCM/G.726 [14] Voice service	a32	O	M	0,1	0,1
2	Generic Access Profile (GAP) supported	a33	O	M	0,1	0,1
3	Non-voice circuit switched service	a34	O	M	0,1	0,1
4	Non-voice packet switched service	a35	O	M	0,1	0,1
5	Standard authentication required	a36	O	M	0,1	0,1
6	Standard ciphering supported	a37	O	M	0,1	0
7	Location registration supported	a38	O	M	0,1	0,1
8	SIM services available	a39	O	M	0,1	0,1
9	Non-static Fixed Part (FP)	a40	O	M	0,1	0,1
10	CISS services available	a41	O	M	0,1	0,1
11	CLMS services available	a42	O	M	0,1	0,1
12	COMS services available	a43	O	M	0,1	0,1
13	Access rights requests supported	a44	O	M	0,1	0,1
14	External handover supported	a45	O	M	0,1	0,1
15	Connection handover supported	a46	O	M	0,1	0,1
16	Reserved	a47	O	M	0,1	0,1

NOTE: ITU-T Recommendation G.726 [14].

C.4.4 Procedure support

Table C.19: Procedures supported

Procedure supported				
Item No.	Name of procedure	Reference	FT Status	LT Status
1	Downlink continuous broadcast	9.1.1	M	M
21a	Basic bearer setup	10.5.1.1	M1	M1
22	A-field advanced single bearer setup	10.5.1.3	M2	M2
23	B-field single bearer setup	10.5.1.3	M3	M3
27	Duplex bearer handover procedure	10.6.2	I	X
29	Unacknowledged bearer release	10.7.2.1	M	M
40	Duplex bearer physical channel selection	11.4.1	-	X
41	Double simplex bearer physical channel selection	11.4.1	-	X
42	Simplex bearer physical channel selection	11.4.1	-	X
45	RFP idle receiver scan sequence	11.8	M	M
46	Test message	12	M	M

C.4.5 CSF multiplexing functions

Table C.20: CSF multiplexing functions

CSF multiplexing functions				
Item No.	Name of function	Reference	FT Status	LT Status
1	D-field MAP D80	6.2.1.1	Ca	Cb
2	D-field MAP D32	6.2.1.1	Ca	Cb
3	D-field MAP D08	6.2.1.1	Ca	Cb
4	D-field MAP D00	6.2.1.1	Ca	Cb
5	A-field MAP	6.2.1.2	M	M
6	B-field MAP D80 unprotected	6.2.1.3	Cc	Cd
7	B-field MAP D32 unprotected	6.2.1.3	Cc	Cd
8	B-field MAP D08 unprotected	6.2.1.3	Cc	Cd
9	B-field MAP D80 protected	6.2.1.3	Cc	Cd
10	B-field MAP D32 protected	6.2.1.3	Cc	Cd
11	B-field MAP D08 protected	6.2.1.3	Cc	Cd
12	Tail multiplexer	6.2.2.1	M	M
13	E/U-mux E80	6.2.2.2	Ce	Cf
14	E/U-mux E32	6.2.2.2	Ce	Cf
15	E/U-mux E08	6.2.2.2	Ce	Cf
16	E/U-mux U80a	6.2.2.2	Ce	Cf
17	E/U-mux U32a	6.2.2.2	Ce	Cf
18	E/U-mux U08a	6.2.2.2	Ce	Cf
19	E/U-mux U08a	6.2.2.2	Ce	Cf
20	E/U-mux U32b	6.2.2.2	Ce	Cf
21	E/U-mux U08b	6.2.2.2	Ce	Cf
32	C-mux DS mode 10	6.2.2.3.1	C3g	C3g
37	C-mux FS mode 4	6.2.2.3.1	C3h	C3h
39	C-mux HS mode 1	6.2.2.3.2	C3i	C3i
40	Encryption	6.2.3	O	O
41	Scrambling	6.2.4	M3	M3
42a	A field R-CRC generation	6.2.5.2	M	M
42b	B-field R-CRC generation	6.2.5.2	M3	M3
43a	A-field R-CRC checking	6.2.5.2	M	M
43b	B-field R-CRC checking	6.2.5.2	M3	M3
44	X-CRC generation	6.2.5.4	M	M
45	X-CRC checking	6.2.5.4	O	O
46	Broadcast control function	6.2.6	M	-

NOTE 1: For A-field setups (i.e. type 1 and 2): only A-field R-CRC is mandatory.
NOTE 2: Ca: At least one shall be supported by the EUT.
NOTE 3: Cb: At least one shall be supported by the LT.
NOTE 4: Cc: At least one shall be supported by the EUT.
NOTE 5: Cd: At least one shall be supported by the LT.
NOTE 6: Ce: At least one shall be supported by the EUT.
NOTE 7: Cf: At least one shall be supported by the LT.
NOTE 8: C3g: Mandatory if double slot supported.
NOTE 9: C3h: Mandatory if full slot supported.
NOTE 10: C3i: Mandatory if half slot supported.

C.4.6 Timer and counter support

Those timers and counters required by the mandatory procedures are classified as mandatory, (see table D.19).

Annex D (normative): Measurement of BER and FER

The LT shall use the following method for calculating BER:

- in frames counted for synchronization loss the bit errors for the frame shall be disregarded;
- only whole numbers of frames shall be tested;
- the threshold used in the EUT to detect synchronization shall be the same for BER measurements as for normal operation:
 - let the total number of frames transmitted by the LT be α ; and
 - let the number of frames counted with synchronization loss be β ; and
 - let the number of bits counted in error be γ ; and
 - Let the number of bits in a frame be ξ ;

then:

$$\text{BER} = \frac{\gamma}{\xi \times (\alpha - \beta)}$$

$$\text{FER} = \frac{\beta}{\alpha}$$

Over the measurement, the FER shall be less than 5 %, except for the test in clause 5.3.8.2, where the FER shall be less than 0,05 %.

For the calculation of the BER the following number N of transmitted bits shall be used:

$$N = (320 + 2\,016 \times (1 - e^{-\text{BER1}/\text{BERL}}))/\text{BERL}$$

where:

BERL - Limit value of BER measurement (depending on test case).

BER1 - BER measured during the first 320 000 bits (for BERL = 0,001) or 32 000 000 bits (for BERL = 0,00001) respectively. If BER1 is greater than BERL then BER1=BERL is used for the calculation.

Annex E (informative): Procedures for the measurement of synchronization loss at the EUT by the LT

E.1 Description

Clause 5.3.8 requires the synchronization loss to be measured within the LT. In order that this can be made possible this annex describes a method by which the EUT can inform the LT when a synchronization error has occurred.

E.2 Method

When a synchronization error occurs the EUT should either:

- 1) re-transmit the last received B-field; or
- 2) transmit all 0's in the B-field;

of the transmit half frame immediately following the loss of synchronization.

The LT should detect the synchronization error by using a threshold method on the bit error count for the frame. If the BER calculated for the frame is less than 25 % then the BER calculated should go towards the total bit error count for the measurement. If the BER calculated is greater than or equal to 25 % then the frame is counted as a synchronization error and the total bit error count is not incremented.

Annex F (informative): DECT carrier numbers and carrier positions in the range 1 880 MHz to 2 025 MHz

F.1 Introduction

RF carriers for IMT-FT applications of DECT are placed within the parts of the European UMTS spectrum applicable for TDD operation. (see ERC/DEC/(99)25 [16], ERC/DEC/(00)01 [17]) e.g. within 1 900 MHz to 1 920 MHz, 1920 MHz to 1 980 MHz and/or 2 010 MHz to 2 025 MHz. IMT-FT equipment may have a second mode providing for operation also in the DECT band 1 880 MHz to 1 900 MHz [18].

DECT carriers are specified for the whole frequency range 1 880 MHz to 2 025 MHz.

An RF carrier is defined by its centre frequency F_c .

The DECT fixed part (base stations of the same system) broadcast messages indicate the locally relevant carriers to ensure that PPs and CTAs set up calls only within the locally allocated band. These broadcast messages from a specific local fixed part contain information on the carrier frequencies of up to 33 carrier positions F_c , and whether each of these is allowed to be used or not. The frequencies for carrier numbers $c = 0, 1, \dots, 9$ are fixed for the band 1 880 MHz to 1 900 MHz, but the frequencies for carriers $c = 10, 11, \dots, 32$ depend on the specific RF band number. See EN 300 175-3 [5] clauses 7.2.3.2.8 and 7.2.3.3.

The carrier numbers $c = 0, 1, 2, \dots, 9$ are for the frequency band 1 880 MHz to 1 900 MHz. Those 10 RF-carrier centre frequencies F_c are given by:

$$F_c = F_0 - c \times 1,728 \text{ MHz}, \quad \text{where: } F_0 = 1\,897,344 \text{ MHz}$$

For extension of carrier positions to cover bands up to 2 025 MHz, a basic set of partially overlapping RF bands have been defined. See below. New or modified carrier positions and/or bands can (locally) be defined when needed.

F.2 1 880 MHz to 1 940 MHz RF band 00001

RF-band number = 00001 defines 23 additional carriers 1 899,072 to 1 937,088 MHz. The carrier frequencies are defined by:

$$F_c = F_9 + c \times 1,728 \text{ MHz, where } F_9 = 1 881,792 \text{ MHz and } c = 10, 11, 12, \dots, 32.$$

The above carrier frequencies are explicitly given in table G.1.

Table F.1: Carrier numbers and carrier positions

Carrier number c	Rf-band number	Carrier freq. MHz	Carrier number c	Rf-band number	Carrier freq. MHz
9	-	1 881,792	17	00001	1 911,168 (note)
8	-	1 883,520	18	00001	1 912,896
7	-	1 885,248	19	00001	1 914,624 (note)
6	-	1 886,876	20	00001	1 916,352
5	-	1 888,704	21	00001	1 918,080
4	-	1 890,432	22	00001	1 919,808 (note)
3	-	1 892,160	23	00001	1 921,536
2	-	1 893,888	24	00001	1 923,264
1	-	1 895,616	25	00001	1 924,992 (note)
0	-	1 897,344	26	00001	1 926,720
10	00001	1 899,072	27	00001	1 928,448
11	00001	1 900,800	28	00001	1 930,176 (note)
12	00001	1 902,528	29	00001	1 931,904
13	00001	1 904,256 (note)	30	00001	1 933,632
14	00001	1 905,984 (note)	31	00001	1 935,360 (note)
15	00001	1 907,712	32	00001	1 937,088
16	00001	1 909,440 (note)			

NOTE: This carrier can normally not be used unless the adjacent 5 MHz spectrum block belongs to the same operator. The spectrum block border frequencies coincide with a frequency $n \times 5$ MHz, where n is an integer.

F.3 1 880 MHz to 1 925 and 2 010 to 2 025 MHz RF band 00010

RF-band number = 00010 defines 23 additional carriers. 15 from 1 899,072 to 1 923,264 MHz and 8 from 2 011,392 to 2 023,488 MHz. The carrier frequencies are defined by:

$$F_c = F_9 + c \times 1,728 \text{ MHz, where } F_9 = 1\,881,792 \text{ MHz and } c = 10, 11, 12, \dots, 24$$

$$F_c = F_9 + (c + 50) \times 1,728 \text{ MHz, where } F_9 = 1\,881,792 \text{ MHz and } c = 25, 26, \dots, 32$$

This RF-band is the preferred band for operation in the spectrum exclusively allocated for TDD operation.

The above carrier frequencies are explicitly given in table G.2.

Table F.2: Carrier numbers and carrier positions

Carrier number c	Rf-band number	Carrier freq. MHz	Carrier number c	Rf-band number	Carrier freq. MHz
9	-	1 881,792	17	00010	1 911,168 (note)
8	-	1 883,520	18	00010	1 912,896
7	-	1 885,248	19	00010	1 914,624 (note)
6	-	1 886,876	20	00010	1 916,352
5	-	1 888,704	21	00010	1 918,080 (note)
4	-	1 890,432	22	00010	1 919,808
3	-	1 892,160	23	00010	1 921,536
2	-	1 893,888	24	00010	1 923,264
1	-	1 895,616	25	00010	2 011,392
0	-	1 897,344	26	00010	2 013,120
10	00010	1 899,072	27	00010	2 014,848
11	00010	1 900,800	28	00010	2 016,576
12	00010	1 902,528	29	00010	2 018,304
13	00010	1 904,256 (note)	30	00010	2 020,032
14	00010	1 905,984 (note)	31	00010	2 021,760
15	00010	1 907,712	32	00010	2 023,488
16	00010	1 909,440 (note)			

NOTE: This carrier can normally not be used unless the adjacent 5 MHz spectrum block belongs to the same operator. The spectrum block border frequencies coincide with a frequency $n \times 5$ MHz, where n is an integer.

F.4 1 880 MHz 1 900 MHz, 1 915 MHz to 1 940 MHz and 2 010 MHz to 2 025 MHz RF band 00011

RF-band number = 00011 defines 22 additional carriers. 14 from 1 916,352 MHz to 1 938,816 MHz and 8 from 2 011,392 MHz to 2 023,488 MHz. The carrier frequencies are defined by:

$$F_c = F_9 + (c + 10) \times 1,728 \text{ MHz, where } F_9 = 1\,881,792 \text{ MHz and } c = 10, 11, 12, \dots, 23$$

$$F_c = F_9 + (c + 50) \times 1,728 \text{ MHz, where } F_9 = 1\,881,792 \text{ MHz and } c = 25, 26, \dots, 32$$

The above carrier frequencies are explicitly given in table G.3.

Table F.3: Carrier numbers and carrier positions

Carrier number c	Rf-band number	Carrier freq. MHz	Carrier number c	Rf-band number	Carrier freq. MHz
9	-	1 881,792	17	00011	1 928,448
8	-	1 883,520	18	00011	1 930,176 (note)
7	-	1 885,248	19	00011	1 931,904
6	-	1 886,876	20	00011	1 933,632
5	-	1 888,704	21	00011	1 935,360 (note)
4	-	1 890,432	22	00011	1 937,088
3	-	1 892,160	23	00011	1 938,816
2	-	1 893,888	24	00011	-
1	-	1 895,616	25	00011	2 011,392
0	-	1 897,344	26	00011	2 013,120
10	00011	1 916,352	27	00011	2 014,848
11	00011	1 918,080	28	00011	2 016,576
12	00011	1 919,808 (note)	29	00011	2 018,304
13	00011	1 921,536	30	00011	2 020,032
14	00011	1 923,264	31	00011	2 021,760
15	00011	1 924,992 (note)	32	00011	2 023,488
16	00011	1 926,720			

NOTE: This carrier can normally not be used unless the adjacent 5 MHz spectrum block belongs to the same operator. The spectrum block border frequencies coincide with a frequency $n \times 5$ MHz, where n is an integer.

F.5 1 880 MHz to 1 900, 1 935 MHz to 1 960 and 2 010 MHz to 2 025 MHz RF band 00100

RF-band number = 00100 defines 22 additional carriers. 14 from 1 937,088 MHz to 1 959,489 MHz and 8 from 2 011.392 MHz to 2 023,488 MHz. The carrier frequencies are defined by:

$$F_c = F_9 + (c + 22) * 1,728 \text{ MHz, where } F_9 = 1 881,792 \text{ MHz and } c = 10, 11, 12, \dots, 23$$

$$F_c = F_9 + (c + 50) * 1,728 \text{ MHz, where } F_9 = 1 881,792 \text{ MHz and } c = 25, 26, \dots, 32$$

The above carrier frequencies are explicitly given in table G.4.

Table F.4: Carrier numbers and carrier positions

Carrier number c	Rf-band number	Carrier freq. MHz	Carrier number c	Rf-band number	Carrier freq. MHz
9	-	1 881,792	17	00100	1 949,184 (note)
8	-	1 883,520	18	00100	1 950,912 (note)
7	-	1 885,248	19	00100	1 952,640
6	-	1 886,876	20	00100	1 954,368 (note)
5	-	1 888,704	21	00100	1 956,096 (note)
4	-	1 890,432	22	00100	1 957,824
3	-	1 892,160	23	00100	-
2	-	1 893,888	24	00100	-
1	-	1 895,616	25	00100	2 011,392
0	-	1 897,344	26	00100	2 013,120
10	00100	1 937,088	27	00100	2 014,848
11	00100	1 938,816	28	00100	2 016,576
12	00100	1 940,544 (note)	29	00100	2 018,304
13	00100	1 942,272	30	00100	2 020,032
14	00100	1 944,000 (note)	31	00100	2 021,760
15	00100	1 945,728 (note)	32	00100	2 023,488
16	00100	1 947,456			

NOTE: This carrier can normally not be used unless the adjacent 5 MHz spectrum block belongs to the same operator. The spectrum block border frequencies coincide with a frequency $n \times 5$ MHz, where n is an integer.

F.6 1 880 MHz to 1 900 MHz, 1 955 MHz to 1 980 MHz and 2 010 MHz to 2 025 MHz RF band 00101

RF-band number = 00100 defines 22 additional carriers. 14 from 1 937,088 MHz to 1 959,489 MHz and 8 from 2 011,392 MHz to 2 023,488 MHz. The carrier frequencies are defined by:

$$F_c = F_9 + (c + 34) * 1,728 \text{ MHz, where } F_9 = 1\,881,792 \text{ MHz and } c = 10, 11, 12, \dots, 23$$

$$F_c = F_9 + (c + 50) * 1,728 \text{ MHz, where } F_9 = 1\,881,792 \text{ MHz and } c = 25, 26, \dots, 32$$

The above carrier frequencies are explicitly given in table G.5.

Table F.5: Carrier numbers and carrier positions

Carrier number c	Rf-band number	Carrier freq. MHz	Carrier number c	Rf-band number	Carrier freq. MHz
9	-	1 881,792	17	00101	1 969,920 (note)
8	-	1 883,520	18	00101	1 971,648
7	-	1 885,248	19	00101	1 973,376
6	-	1 886,876	20	00101	1 075,104 (note)
5	-	1 888,704	21	00101	1 976,832
4	-	1 890,432	22	00101	1 978,560
3	-	1 892,160	23	00101	-
2	-	1 893,888	24	00101	-
1	-	1 895,616	25	00101	2 011,392
0	-	1 897,344	26	00101	2 013,120
10	00101	1 957,824	27	00101	2 014,848
11	00101	1 959,552 (note)	28	00101	2 016,576
12	00101	1 961,280	29	00101	2 018,304
13	00101	1 963,008	30	00101	2 020,032
14	00101	1 964,736 (note)	31	00101	2 021,760
15	00101	1 966,464	32	00101	2 023,488
16	00101	1 968,192			

NOTE: This carrier can normally not be used unless the adjacent 5 MHz spectrum block belongs to the same operator. The spectrum block border frequencies coincide with a frequency $n \times 5$ MHz, where n is an integer.

Annex G (informative): The EN title in the official languages

Language	EN title
Danish	
Dutch	
English	Electromagnetic compatibility and Radio spectrum Matters (ERM); Base stations (BS) and user equipment (UE) for IMT-2000 Third-Generation cellular networks; Part 10: Harmonized standard for IMT-2000 FDMA/TDMA (DECT) covering essential requirements of article 3.2 of the R&TTE Directive
Finnish	
French	
German	
Greek	
Icelandic	
Italian	
Portuguese	
Spanish	
Swedish	

Annex H (informative): Bibliography

Directive 98/34/EC of the European Parliament and of the Council of 22 June 1998 laying down a procedure for the provision of information in the field of technical standards and regulations.

History

Document history			
V1.1.1	April 2001	Public Enquiry	PE 20010824: 2001-04-25 to 2001-08-24