

Draft **ETSI EN 301 908-8** V1.1.1 (2001-04)

Candidate Harmonized European Standard (Telecommunications series)

**Electromagnetic compatibility
and Radio spectrum Matters (ERM);
Base Stations (BS) and User Equipment (UE) for
IMT-2000 Third-Generation cellular networks;
Part 8: Harmonized standard for IMT-2000,
TDMA Single-Carrier (UWC 136) (UE)
covering essential requirements of
article 3.2 of the R&TTE Directive**



Reference

DEN/ERM-TFES-001-8

Keywords3G, cellular, digital, EDGE, IMT-2000, mobile,
radio, regulation, TDMA, UMTS, UWC 136**ETSI**650 Route des Lucioles
F-06921 Sophia Antipolis Cedex - FRANCE

Tel.: +33 4 92 94 42 00 Fax: +33 4 93 65 47 16

Siret N° 348 623 562 00017 - NAF 742 C
Association à but non lucratif enregistrée à la
Sous-Préfecture de Grasse (06) N° 7803/88

Important notice

Individual copies of the present document can be downloaded from:

<http://www.etsi.org>

The present document may be made available in more than one electronic version or in print. In any case of existing or perceived difference in contents between such versions, the reference version is the Portable Document Format (PDF). In case of dispute, the reference shall be the printing on ETSI printers of the PDF version kept on a specific network drive within ETSI Secretariat.

Users of the present document should be aware that the document may be subject to revision or change of status. Information on the current status of this and other ETSI documents is available at <http://www.etsi.org/tb/status/>

If you find errors in the present document, send your comment to:
editor@etsi.fr

Copyright Notification

No part may be reproduced except as authorized by written permission.
The copyright and the foregoing restriction extend to reproduction in all media.

© European Telecommunications Standards Institute 2001.
All rights reserved.

Contents

Intellectual Property Rights	6
Foreword	6
Introduction	8
1 Scope	10
2 References	10
3 Definitions and abbreviations	11
3.1 Definitions	11
3.2 Abbreviations	12
4 Technical requirements specifications	12
4.1 Environmental profile	12
4.2 Conformance requirements	12
4.2.1 Introduction	12
4.2.2 Conformance requirements (30kHz)	13
4.2.2.1 Adjacent and alternate channel power due to modulation	13
4.2.2.1.1 Definition	13
4.2.2.1.2 Limits	13
4.2.2.1.3 Conformance	13
4.2.2.2 Out of band power arising from switching transients	13
4.2.2.2.1 Definition	13
4.2.2.2.2 Limits	14
4.2.2.2.3 Conformance	14
4.2.2.3 Harmonic and spurious emissions (conducted)	14
4.2.2.3.1 Definition	14
4.2.2.3.2 Limits	14
4.2.2.3.2.1 Spurious emissions, (Category B)	14
4.2.2.3.2.2 Co-existence with services in adjacent frequency bands	14
4.2.2.3.3 Conformance	15
4.2.2.4 RF power output	15
4.2.2.4.1 Definition	15
4.2.2.4.2 Limits	16
4.2.2.4.3 Conformance	16
4.2.2.5 Blocking and spurious-response rejection	16
4.2.2.5.1 Definition	16
4.2.2.5.2 Limits	17
4.2.2.5.3 Conformance	17
4.2.2.6 Adjacent and alternate channel desensitization	17
4.2.2.6.1 Definition	17
4.2.2.6.2 Limits	18
4.2.2.6.3 Conformance	18
4.2.2.7 Receiver spurious emissions (idle mode)	18
4.2.2.7.1 Definition	18
4.2.2.7.2 Limits	18
4.2.2.7.3 Conformance	18
4.2.3 Conformance requirements (200kHz)	18
4.2.3.1 Output RF spectrum	18
4.2.3.1.1 Definition	18
4.2.3.1.2 Limits	18
4.2.3.1.2.1 Introduction	18
4.2.3.1.2.2 Spectrum due to the modulation and wide band noise	19
4.2.3.1.2.3 Spectrum due to switching transients	22
4.2.3.1.3 Conformance	23
4.2.3.2 Transmitter conducted spurious emissions	24
4.2.3.2.1 Definition	24

4.2.3.2.2	Limits	24
4.2.3.2.2.1	Spurious emissions, (Category B).....	24
4.2.3.2.2.2	Co-existence with services in adjacent frequency bands.....	24
4.2.3.2.3	Conformance.....	24
4.2.3.3	Transmitter output power.....	25
4.2.3.3.1	Definition.....	25
4.2.3.3.2	Limits	25
4.2.3.3.3	Conformance.....	28
4.2.3.4	Impact of interference on receiver performance	28
4.2.3.4.1	Introduction	28
4.2.3.4.2	Blocking and spurious response.....	28
4.2.3.4.2.1	Definition	28
4.2.3.4.2.2	Limits.....	28
4.2.3.4.2.3	Conformance.....	29
4.2.3.4.3	Intermodulation rejection.....	29
4.2.3.4.3.1	Definition	29
4.2.3.4.3.2	Limits.....	29
4.2.3.4.3.3	Conformance.....	29
4.2.3.5	Co-channel rejection.....	29
4.2.3.5.1	Definition.....	29
4.2.3.5.2	Limits	29
4.2.3.5.3	Conformance.....	30
4.2.3.6	Receiver adjacent channel selectivity	30
4.2.3.6.1	Definition.....	30
4.2.3.6.2	Limits	31
4.2.3.6.3	Conformance.....	31
4.2.3.7	Receiver spurious emissions (idle mode).....	31
4.2.3.7.1	Definition.....	31
4.2.3.7.2	Limits	32
4.2.3.7.3	Conformance.....	32
5	Testing for compliance with technical requirements	32
5.1	Environmental conditions for testing.....	32
5.2	Test conditions	32
5.2.1	Standard test equipment (30 kHz).....	32
5.2.1.1	Standard test source	32
5.2.1.2	Standard test receiver.....	33
5.2.1.3	Spectrum analyser or measuring receiver.....	33
5.2.1.4	Modulation accuracy measurement equipment	33
5.2.1.5	Standard BER/WER test equipment	34
5.2.1.6	Standard Protocol Test Equipment	34
5.2.1.7	Standard Channel Simulator.....	34
5.2.2	Standard test environment	36
5.3	Interpretation of the test results	36
5.3.1	Measurement uncertainties	36
5.3.2	Interpretation of the measurement results.....	37
5.4	Essential radio test suites	38
5.4.1	Essential radio test suites (30 kHz)	38
5.4.1.1	Spectrum emissions mask	38
5.4.1.1.1	Adjacent and alternate channel power due to modulation	38
5.4.1.1.2	Out of band power arising from switching transients	38
5.4.1.2	Transmitter conducted spurious emissions.....	39
5.4.1.3	Accuracy of maximum output power.....	39
5.4.1.4	Impact of interference on receiver performance.....	39
5.4.1.5	Receiver adjacent channel selectivity	40
5.4.1.6	Receiver conducted spurious emissions.....	40
5.4.1.6.1	Initial conditions	40
5.4.1.6.2	Test procedure.....	40
5.4.2	Essential radio test suites (200 kHz)	40
5.4.2.1	Spectrum emissions mask	40
5.4.2.1.1	Initial conditions	40
5.4.2.1.2	Test procedure.....	41

5.4.2.2	Conducted spurious emissions	42
5.4.2.2.1	Initial conditions	42
5.4.2.2.2	Procedure.....	43
5.4.2.3	Accuracy of maximum output power.....	43
5.4.2.3.1	Introduction	43
5.4.2.3.2	Method of test for equipment with a permanent antenna connector	44
5.4.2.3.2.1	Initial conditions.....	44
5.4.2.3.2.2	Test procedure.....	44
5.4.2.3.3	Method of test for equipment with an integral antenna	45
5.4.2.3.3.1	Initial conditions.....	45
5.4.2.3.3.2	Test procedure.....	45
5.4.2.4	Impact of interference on receiver performance.....	46
5.4.2.4.1	Blocking and spurious response.....	46
5.4.2.4.1.1	Initial conditions.....	46
5.4.2.4.1.2	Test procedure for GMSK modulation.....	46
5.4.2.4.1.3	Test procedures for 8-PSK modulation:.....	48
5.4.2.4.2	Intermodulation rejection.....	49
5.4.2.4.2.1	Initial conditions.....	49
5.4.2.4.2.2	Test procedure for GMSK modulation:.....	50
5.4.2.4.2.3	Test procedures for 8-PSK Modulation:.....	50
5.4.2.5	Receiver co-channel rejection	52
5.4.2.5.1	Initial conditions	52
5.4.2.5.2	Test procedure.....	52
5.4.2.6	Receiver adjacent channel selectivity	53
5.4.2.6.1	Initial conditions.....	53
5.4.2.6.1.1	Test procedure for GMSK modulation.....	53
5.4.2.6.1.2	Test procedures for 8-PSK modulation:.....	54
5.4.2.7	Receiver conducted spurious emissions.....	55
5.4.2.7.1	Initial conditions	55
5.4.2.7.2	Test procedure.....	55
Annex A (normative):	The EN Requirements Table (EN-RT).....	56
Annex B (normative):	Propagation conditions	58
B.1	Simple wideband propagation model.....	58
B.2	Doppler spectrum types	58
B.3	Propagation models	59
B.4	Receiver reference sensitivity	60
Annex C (informative):	Normal and extreme test conditions (TC).....	65
C.1	Power sources and ambient temperatures (TC2).....	65
C.1.1	Normal test conditions (TC2.1).....	65
C.1.2	Extreme test conditions (TC2.2)	65
Annex D (informative):	Source specifications for clauses 4 and 5.....	67
Annex E (informative):	The EN title in the official languages.....	68
Annex F (informative):	Bibliography.....	69
History		70

Intellectual Property Rights

IPRs essential or potentially essential to the present document may have been declared to ETSI. The information pertaining to these essential IPRs, if any, is publicly available for **ETSI members and non-members**, and can be found in ETSI SR 000 314: *"Intellectual Property Rights (IPRs); Essential, or potentially Essential, IPRs notified to ETSI in respect of ETSI standards"*, which is available from the ETSI Secretariat. Latest updates are available on the ETSI Web server (<http://www.etsi.org/ipr>).

Pursuant to the ETSI IPR Policy, no investigation, including IPR searches, has been carried out by ETSI. No guarantee can be given as to the existence of other IPRs not referenced in SR 000 314 (or the updates on the ETSI Web server) which are, or may be, or may become, essential to the present document.

Foreword

This Candidate Harmonized European Standard (Telecommunications series) has been produced by ETSI Technical Committee Electromagnetic compatibility and Radio spectrum Matters (ERM), and is now submitted for the Public Enquiry phase of the ETSI standards Two-step Approval Procedure.

The present document is part 8 of a multi-part deliverable covering the Base Stations (BS) and User Equipment (UE) for IMT-2000 Third-Generation cellular networks, as identified below:

- Part 1: "Harmonized standard for IMT-2000, Introduction and common requirements, covering essential requirements of article 3.2 of the R&TTE Directive";
- Part 2: "Harmonized standard for IMT-2000, CDMA Direct Spread (UTRA FDD) (UE) covering essential requirements of article 3.2 of the R&TTE Directive";
- Part 3: "Harmonized standard for IMT-2000, CDMA Direct Spread (UTRA FDD) (BS) covering essential requirements of article 3.2 of the R&TTE Directive";
- Part 4: "Harmonized standard for IMT-2000, CDMA Multi-Carrier (cdma2000) (UE) covering essential requirements of article 3.2 of the R&TTE Directive";
- Part 5: "Harmonized standard for IMT-2000, CDMA Multi-Carrier (cdma2000) (BS) covering essential requirements of article 3.2 of the R&TTE Directive";
- Part 6: "Harmonized standard for IMT-2000, CDMA TDD (UTRA TDD) (UE) covering essential requirements of article 3.2 of the R&TTE Directive";
- Part 7: "Harmonized standard for IMT-2000, CDMA TDD (UTRA TDD) (BS) covering essential requirements of article 3.2 of the R&TTE Directive";
- Part 8: "Harmonized standard for IMT-2000, TDMA Single-Carrier (UWC 136) (UE) covering essential requirements of article 3.2 of the R&TTE Directive";**
- Part 9: "Harmonized standard for IMT-2000, TDMA Single-Carrier (UWC 136) (BS) covering essential requirements of article 3.2 of the R&TTE Directive";
- Part 10: "Harmonized standard for IMT-2000 FDMA/TDMA (DECT) covering essential requirements of article 3.2 of the R&TTE Directive".

The present document has been produced by ETSI in response to a mandate from the European Commission issued under Council Directive 98/34/EC laying down a procedure for the provision of information in the field of technical standards and regulations.

The present document is intended to become a Harmonized Standard, the reference of which will be published in the Official Journal of the European Communities referencing the Directive 1999/5/EC [1] of the European Parliament and of the Council of 9 March 1999 on radio equipment and telecommunications terminal equipment and the mutual recognition of their conformity ("the R&TTE Directive").

Proposed national transposition dates	
Date of latest announcement of this EN (doa):	3 months after ETSI publication
Date of latest publication of new National Standard or endorsement of this EN (dop/e):	6 months after doa
Date of withdrawal of any conflicting National Standard (dow):	18 months after doa

Introduction

The present document is part of a set of standards designed to fit in a modular structure to cover all radio and telecommunications terminal equipment under the R&TTE Directive. Each standard is a module in the structure. The modular structure is shown in figure 1.

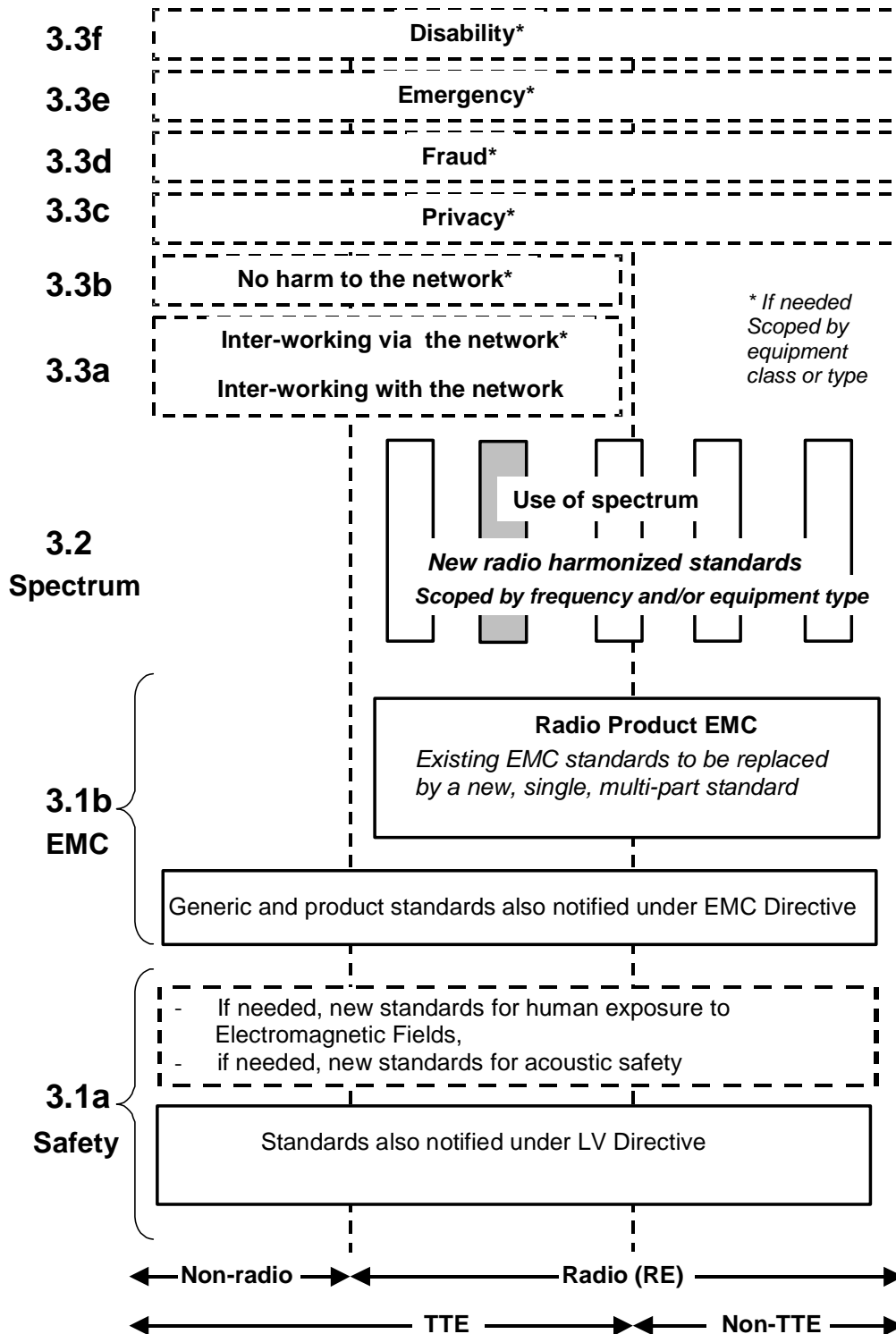

Figure 1: Modular structure for the various standards used under the R&TTE Directive

The left hand edge of the figure 1 shows the different clauses of article 3 of the R&TTE Directive.

For article 3.3 various horizontal boxes are shown. Dotted lines indicate that at the time of publication of the present document essential requirements in these areas have to be adopted by the Commission. If such essential requirements are adopted, and as far and as long as they are applicable, they will justify individual standards whose scope is likely to be specified by function or interface type.

The vertical boxes show the standards under article 3.2 for the use of the radio spectrum by radio equipment. The scopes of these standards are specified either by frequency (normally in the case where frequency bands are harmonized) or by radio equipment type.

For article 3.1b the diagram shows EN 301 489 [7], the multi-part product EMC standard for radio, and the existing collection of generic and product standards currently used under the EMC Directive [2].

For article 3.1a the diagram shows the existing safety standards currently used under the LV Directive [3] and new standards covering human exposure to electromagnetic fields. New standards covering acoustic safety may also be required.

The bottom of the figure shows the relationship of the standards to radio equipment and telecommunications terminal equipment. A particular equipment may be radio equipment, telecommunications terminal equipment or both. A radio spectrum standard will apply if it is radio equipment. An article 3.3 standard will apply as well only if the relevant essential requirement under the R&TTE Directive is adopted by the Commission and if the equipment in question is covered by the scope of the corresponding standard. Thus, depending on the nature of the equipment, the essential requirements under the R&TTE Directive may be covered in a set of standards.

The modularity principle has been taken because:

- it minimizes the number of standards needed. Because equipment may, in fact, have multiple interfaces and functions it is not practicable to produce a single standard for each possible combination of functions that may occur in an equipment;
- it provides scope for standards to be added:
 - under article 3.2 when new frequency bands are agreed; or
 - under article 3.3 should the Commission take the necessary decisions without requiring alteration of standards that are already published;
- it clarifies, simplifies and promotes the usage of Harmonized Standards as the relevant means of conformity assessment.

The product specifications upon which this multi-part deliverable is based, differ in presentation; and this is reflected in the present document

1 Scope

The present document applies to the following radio equipment types:

1. IMT-2000 TDMA-SC UE.

These radio equipment types are capable of operating in all or any part of the frequency bands given in table 1.

Table 1: IMT-2000 TDMA-SC frequency bands

Direction of transmission	IMT-2000 TDMA-SC frequency bands
Receive	2 110 to 2 170 MHz
Transmit	1 920 to 1 980 MHz

The present document is intended to cover the provisions of Directive 1999/5/EC [1] (R&TTE Directive) article 3.2, which states that "... radio equipment shall be so constructed that it effectively uses the spectrum allocated to terrestrial/space radio communications and orbital resources so as to avoid harmful interference".

IMT-2000 TDMA-SC specifies operation over 30 kHz and 200 kHz channels. The present document specifies the requirements for these channels in separate clauses.

In addition to the present document, other ENs that specify technical requirements in respect of essential requirements under other parts of article 3 of the R&TTE Directive will apply to equipment within the scope of the present document.

NOTE: A list of such ENs is included on the web site <http://www.newapproach.org/>.

2 References

The following documents contain provisions which, through reference in this text, constitute provisions of the present document.

- References are either specific (identified by date of publication and/or edition number or version number) or non-specific.
- For a specific reference, subsequent revisions do not apply.
- For a non-specific reference, the latest version applies.

- [1] Directive 1999/5/EC of the European Parliament and of the Council of 9 March 1999 on radio equipment and telecommunications terminal equipment and the mutual recognition of their conformity (R&TTE Directive).
- [2] Council Directive 89/336/EEC of 3 May 1989 on the approximation of the laws of the Member States relating to electromagnetic compatibility (EMC Directive).
- [3] Council Directive 73/23/EEC of 19 February 1973 on the harmonization of the laws of Member States relating to electrical equipment designed for use within certain voltage limits (LV Directive).
- [4] ANS TIA/EIA-136-131-B (2000): "TDMA Third Generation Wireless, Digital Traffic Channel, Layer 1" (included by reference into Recommendation ITU-R M.1457: Detailed Specifications of the Radio Interfaces of IMT-2000).
- [5] ANS TIA/EIA-136-270-B (2000): "TDMA Third Generation Wireless, Mobile Station Minimum Performance" (included by reference into Recommendation ITU-R M.1457: Detailed Specifications of the Radio Interfaces of IMT-2000).
- [6] ANS TIA/EIA-136-121-A (1999): "TDMA Cellular PCS, Digital Control Channel Layer 1" (included by reference into Recommendation ITU-R M.1457: Detailed Specifications of the Radio Interfaces of IMT-2000).

- [7] ETSI EN 301 489: "Electromagnetic compatibility and Radio spectrum Matters (ERM); ElectroMagnetic Compatibility (EMC) standard for radio equipment and services".
- [8] ETSI EN 300 910 (V8.4.1): "Digital cellular telecommunications system (Phase 2+); Radio transmission and reception (GSM 05.05 version 8.4.1 Release 1999)".
- [9] ETSI EN 300 911: "Digital cellular telecommunications system (Phase 2+); Radio subsystem link control (GSM 05.08 version 8.4.1 Release 1999)".
- [10] ETSI ETR 028 (Edition 2): "Radio Equipment and Systems (RES); Uncertainties in the measurement of mobile radio equipment characteristics".
- [11] ANS TIA/EIA-136-290 (2000): "TDMA Third Generation Wireless, RF Minimum Performance for 136HS Outdoor and 136HS Indoor Bearers" (included by reference into Recommendation ITU-R M.1457: Detailed Specifications of the Radio Interfaces of IMT-2000).
- [12] CEPT/ERC/Recommendation 74-01E (1999): "Spurious Emissions Siofok 1998".
- [13] ITU-R recommendation SM.329-8: "Spurious emissions".
- [14] ETSI TS 151 010-1: "Digital cellular telecommunications system (Phase 2+); Mobile Sation (MS) conformance specification; Part 1: Conformance specification (3GPP T 51.010-1 version 4.1.0 Release 4)".

3 Definitions and abbreviations

3.1 Definitions

For the purposes of the present document, the terms and definitions given in the R&TTE Directive and the following apply:

environmental profile: Range of environmental conditions under which equipment within the scope of the present document is required to comply with the provisions of EN 301 908-8.

BER (Bit Error Ratio): ratio of the bits wrongly received to all data bits sent

BLER (Block Error Ratio): ratio of blocks received in error to the total number of received blocks, where a block is defined as received in error if the error detection functions in the receiver indicate an error as the result of the Block Check Sequence (BCS)

For USF the Block Error Ratio is the ratio of incorrectly interpreted USF to the total number of received USF.

ESID (Erased SID Frame Ratio): A SID Frame is erased (SID=0) when the UE does not detect a valid transmitted SID frame as a valid SID frame (SID=2), or an invalid SID frame (SID=1). The Erased SID Frame Ratio is defined as the ratio of erased SID frames (SID=0), to the total number of valid SID frames transmitted.

EVSIDR (Erased Valid SID Frame Ratio): declared when the UE does not detect a valid transmitted SID frame as a valid SID frame (SID=2) and (BFI=0 and UFI=0).

The Erased Valid SID Frame Ratio is defined as the ratio of erased valid SID frames (SID=0), or (SID=1), or ((BFI or UFI)=1), to the total number of valid SID frames transmitted.

FER (Frame Erasure Rate): A frame is defined as erased if the error detection functions in the receiver indicate an error (BFI = 1).

For full rate or half rate speech this is the result of the 3 bit cyclic redundancy check (CRC) as well as other processing functions that cause a Bad Frame Indication (BFI). For signalling channels it is the result of the FIRE code or any other block code used. For data traffic FER is not defined.

RBER (Residual Bit Error Ratio): Bit Error Ratio (BER) in frames which have not been declared as erased

UFR (Unreliable Frame Ratio): ratio of frames declared as erased (BFI=1), or unreliable (UFI=1), to the total number of frames transmitted

An unreliable frame is indicated by setting the UFI flag (UFI=1) and an erased frame is indicated by setting the BFI flag (BFI=1).

TBF (Temporary Block Flow): connection used by the two radio resource peer entities to support the unidirectional transfer on packet data physical channels

3.2 Abbreviations

For the purposes of the present document, the following abbreviations apply:

B	Appropriate frequency in the Bottom of the operating frequency band of the UE
BCS	Block Check Sequence
BER	Bit Error Ratio
BLER	Block Error Ratio
BS	Base Station
DVCC	Digital Verification Colour Code
EMC	Electro-Magnetic Compatibility
ESID	Erased SID Frame Ratio
EVSIDR	Erased Valid SID Frame Ratio
FER	Frame Erasure Rate
HT/no FH	Hilly Terrain/No Frequency Hopping
LV	Low Voltage
M	Appropriate frequency in the Middle of the operating frequency band of the UE
MCS	Modulation and Coding Scheme
PCCH	Packet Control CHannel
PDTCH	Packet Data Traffic CHannel
R&TTE	Radio and Telecommunications Terminal Equipment
RA/no FH	Random Access/no Frequency Hopping
RBER	Residual Bit Error Ratio
RLC	Radio Link Control
SACCH	Slow Associated Control Channel
SS	System Simulator
T	Appropriate frequency in the Top of the operating frequency band of the UE
TUhigh/no FH	Typical Urban/ no Frequency Hopping
UE	User equipment
UFR	Unreliable Frame Ratio
USF	Uplink Status Flag
TBF	Temporary Block Flow

4 Technical requirements specifications

4.1 Environmental profile

The technical requirements of the present document apply under the environmental profile for operation of the equipment, which shall be declared by the supplier. The equipment shall comply with all the technical requirements of the present document at all times when operating within the boundary limits of the declared operational environmental profile.

4.2 Conformance requirements

4.2.1 Introduction

To meet the essential requirement under article 3.2 of the R&TTE Directive [1] for IMT-2000 TDMA-SC user equipment (UE) six essential parameters have been identified. Tables 2 and 3 provide a cross-reference between these essential parameters and the corresponding technical requirements for equipment within the scope of the present document.

Table 2: Cross-references 30 kHz

Essential parameter	Corresponding technical requirements
Spectrum emissions mask	4.2.2.1 Adjacent and alternate channel power due to modulation 4.2.2.2 Out of band power arising from switching transients
Conducted spurious emissions	4.2.2.3 Harmonic and spurious emissions (conducted)
Accuracy of maximum output power	4.2.2.4 RF power output
Impact of interference on receiver performance	4.2.2.5 Blocking and spurious-response rejection
Receiver adjacent channel selectivity	4.2.2.6 Adjacent and alternate channel desensitization
Receiver conducted spurious emissions	4.2.2.7 Receiver conducted spurious emissions (Idle mode)

Table 3: Cross-references 200 kHz

Essential parameter	Corresponding technical requirements
Spectrum emissions mask	4.2.3.1 Output RF spectrum
Conducted spurious emissions	4.2.3.2 Transmitter conducted spurious emissions
Accuracy of maximum output power	4.2.3.3 Transmitter output power
Impact of interference on receiver performance	4.2.3.4.2 Blocking and spurious response
	4.2.3.4.3 Intermodulation rejection
	4.2.3.5 Cochannel rejection
Receiver adjacent channel selectivity	4.2.3.6 Adjacent channel selectivity
Receiver conducted spurious emissions	4.2.3.7 Receiver conducted spurious emissions (Idle mode)

4.2.2 Conformance requirements (30kHz)

4.2.2.1 Adjacent and alternate channel power due to modulation

4.2.2.1.1 Definition

Spectrum noise suppression is the restraint of sideband energy outside the active transmit channel. This RF spectrum is the result of power ramping, modulation and all sources of noise. The spectrum is primarily the result of events that do not occur at the same time: digital modulation, and power ramping (switching transients). The RF spectrum from these two events is specified separately.

Adjacent and first or second alternate channel power is that part of the mean power output of the transmitter resulting from the modulation and noise: which falls within a specified passband centred on either of the adjacent or first or second alternate channels.

4.2.2.1.2 Limits

The emission power in either adjacent channel, centred ± 30 kHz from the centre frequency, shall not exceed a level of 26 dB below the mean output power. The emission power in either alternate channel, centred ± 60 kHz from the centre frequency, shall not exceed a level of 45 dB below the mean output power. The emission power in either second alternate channel centred ± 90 kHz from the centre frequency, shall not exceed a level of 45 dB below the mean output power or -13 dBm measured in 30 kHz bandwidth, whichever is the lower power.

4.2.2.1.3 Conformance

Conformance tests described in clause 5.4.1.1.1 shall be performed.

4.2.2.2 Out of band power arising from switching transients

4.2.2.2.1 Definition

Spectrum noise suppression is the restraint of sideband energy outside the active transmit channel. This RF spectrum is the result of power ramping, modulation and all sources of noise. The spectrum is primarily the result of events that do not occur at the same time: digital modulation, and power ramping (switching transients). The RF spectrum from these two events is specified separately.

The out of band power arising from switching transients is the peak power of the spectrum, arising from the ramping-on and ramping-off of the transmitter, that fall within defined frequency bands outside the active transmit channel.

4.2.2.2.2 Limits

The peak emission power in either adjacent channel, centred ± 30 kHz from the centre frequency, shall not exceed a level of 26 dB below the peak output power reference. The peak emission power in either alternate channel, centred ± 60 kHz from the centre frequency, shall not exceed a level of 45 dB below the peak output power reference. The peak emission power in either second alternate channel centred ± 90 kHz from the centre frequency, shall not exceed a level of 45 dB below the peak output power reference or -13 dBm, measured in 30 kHz bandwidth, whichever is the lower power.

4.2.2.2.3 Conformance

Conformance tests described in clause 5.4.1.1.2 shall be performed.

4.2.2.3 Harmonic and spurious emissions (conducted)

4.2.2.3.1 Definition

Conducted harmonic and spurious emissions are emissions at the antenna terminal on a frequency or frequencies that are outside the authorized bandwidth of the transmitter. Reduction in the level of these spurious emissions will not affect the quality of the information being transmitted.

4.2.2.3.2 Limits

4.2.2.3.2.1 Spurious emissions, (Category B)

The power of any spurious emission shall not exceed the limits specified in table 4. This requirement is consistent with the recommendations of CEPT/ERC REC 74-01, annex 2 [12].

Table 4: UE mandatory spurious emission limits, Category B

Band (f)	Maximum level	Measurement bandwidth	Note
$9 \text{ kHz} \leq f \leq 150 \text{ kHz}$	-36 dBm	1 kHz	1
$150 \text{ kHz} < f \leq 30 \text{ MHz}$	-36 dBm	10 kHz	1
$30 \text{ MHz} < f \leq 1\,000 \text{ MHz}$	-36 dBm	100 kHz	1
$1\,000 \text{ MHz} < f < 1\,920 \text{ MHz}$	-30 dBm	1 MHz	1
$1\,920 \text{ MHz} \leq f \leq 1\,980 \text{ MHz}$	-30 dBm	30 kHz	2
$1\,980 \text{ MHz} < f < 2\,110 \text{ MHz}$	-30 dBm	1 MHz	1
$2\,110 \text{ MHz} \leq f \leq 2\,170 \text{ MHz}$	-70 dBm	30 kHz	3
$2\,170 \text{ MHz} < f \leq 12,75 \text{ GHz}$	-30 dBm	1 MHz	1
NOTE 1: In accordance with the applicable clauses of [13].			
NOTE 2: UE transmit band.			
NOTE 3: UE receive band.			
NOTE 4: f is the frequency of the spurious emission.			

4.2.2.3.2.2 Co-existence with services in adjacent frequency bands

This requirement provides for the protection of receivers operating in bands adjacent to the UE transmit frequency band of 1 920 MHz to 1 980 MHz; GSM 400, GSM 900, R-GSM and UTRA-TDD.

NOTE: UTRA FDD operates in the same frequency band as UWC 136.

The power of any spurious emission shall not exceed the limits specified in table 5.

Table 5: Additional spurious emissions requirements

Service	Frequency Band	Measurement Bandwidth	Limit
GSM 450	$460,4 \leq f \leq 467,6$ MHz	100kHz	-67 dBm
GSM 480	$488,8 \leq f \leq 496,0$ MHz	100kHz	-67 dBm
R-GSM	$921 \text{ MHz} \leq f \leq 925 \text{ MHz}$	100kHz	-60 dBm
R-GSM	$925 \text{ MHz} < f \leq 935 \text{ MHz}$	100 KHz	-67 dBm
GSM 900/R-GSM	$935 \text{ MHz} < f \leq 960 \text{ MHz}$	100 KHz	-79 dBm
DCS 1 800	$1\ 805 \text{ MHz} \leq f \leq 1\ 880 \text{ MHz}$	100 KHz	-71 dBm
UTRA TDD	$1\ 900 \text{ MHz} \leq f \leq 1\ 920 \text{ MHz}$	100 KHz	-62 dBm
	$2\ 010 \text{ MHz} \leq f \leq 2\ 025 \text{ MHz}$	100 KHz	-62 dBm

NOTE: The measurements are made on frequencies which are integer multiples of 200 kHz. Up to five exceptions of up to -36dBm are permitted in the GSM 900, DCS 1800 and UTRA bands, and up to three exceptions of up to -36dBm are permitted in the GSM 400 bands.

4.2.2.3.3 Conformance

Conformance tests described in clause 5.4.1.2 shall be performed.

4.2.2.4 RF power output

4.2.2.4.1 Definition

The mean effective radiated power (ERP) of the UE is shown in table 6. The manufacturer shall recommend the net power gain or loss of the antenna system to be installed with the UE such that the power measured at the transmitter output terminals can be directly related to the required ERP (typical antenna systems have 2,5 dB gain with respect to a half-wave dipole and 1,5 dB cable loss). The station class indicated by the UE at the beginning of any call will be assumed by the system to be maintained throughout that call.

Table 6: UE nominal power levels

UE Power Level (PL)	UE Attenuation Code (MAC)	Nominal ERP (dBW) for UE power class (see note 4)			
		II	III	IV	V
0	0000	0,0	-	-2	
1	0001	0,0	-	-2	
2	0010	-2	-	-2	
3	0011	-6	-	-6	
4	0100	-10	-	-10	-10
5	0101	-14	-	-14	-14
6	0110	-18	-	-18	-18
7	0111	-22	-	-22	-22
8	1000	-28 ± 4 dB	-	-28 ± 4 dB	-28 ± 4 dB
9	1001	-33 ± 5 dB	-	-33 ± 5 dB	-33 ± 5 dB
10	1010	-38 ± 6 dB	-	-38 ± 6 dB	-38 ± 6 dB

NOTE 1: In case of power classes II and IV the output powers shown above shall be maintained within the range of +2 dB/-4 dB of the nominal value for power levels 0 to 7, and within +2 dB/-6 dB of the nominal value for power levels 8 to 10 (see note 3). In case of power class V the output powers shown above shall be maintained within the range of +2 dB/-2 dB of the nominal value for the power levels 0 to 2, and within +2 dB/-3 dB of the nominal value for power level 3. Ranges for other power levels are the same as for power class IV.

NOTE 2: The nominal output power for levels 8, 9, and 10 are expressed as a range, rather than an absolute value. When the UE changes to one of these power levels, it shall insure that it stabilizes within the range centred around the target value for that level. For example, the target value for power level 8 is -28 dBW. The UE is considered to be within the requirement provided it stabilizes within 4 dB of this target level. Once the UE has stabilized, the operating tolerance is applied to the specific value within the nominal range on which the UE stabilized.

NOTE 3: The nominal ERP values in watts for power level 0 are shown in table 7.

Table 7: Nominal ERP levels

Class	Power Level
II	+0 dBW = 1,0 W
III	Reserved
IV	-2 dBW = 0,6 W
V	-5 dBW = 0,3 W

NOTE 4: Power class V is allowed only in full-duplex, double or triple rate data operation. Voice services and devices capable of only full-rate data operation are not allowed in class V. When operating in half-duplex mode, the power class V terminal shall use values specified for power class IV.

When the UE changes from power level X to power level X + 1, it shall satisfy the requirements for the nominal output power for that level (see table 6). Additionally, the UE shall satisfy the requirements identified for the relative step accuracy going into the X + 1 power level (see table 8). Thus, the UE shall reduce its power such that it conforms to the nominal level, with a reduction in power at least as great as the minimum specified by the relative step requirement.

Table 8: Relative step accuracy -vs- power level on a single channel

UE power class II levels (PL)	UE power class IV levels (PL)	UE power class V levels (PL)	Step between successive power levels (dB)
-	-	2..3	2 ± 1
-	-	3..4	3 ± 1
0.. 7	2..7	4..7	4 ± 1
-	7..10	7..10	4 ± 2

NOTE 5: The power classes IV and V and step between successive power levels columns indicate the dB reduction required when changing from the current power level to the next higher power level. Thus, the change from level 6 to level 7 utilizes the top row criteria; while the change from level 7 to level 8 uses the bottom row criteria.

The digital RF power output of the transmitter is the mean power during the burst available at the output terminals of the transmitter when the terminals are connected to the nominal load impedance.

4.2.2.4.2 Limits

The transmitter shall be capable of multiple power levels as defined in table 6.

4.2.2.4.3 Conformance

Conformance tests described in clause 5.4.1.3 shall be performed.

4.2.2.5 Blocking and spurious-response rejection

4.2.2.5.1 Definition

Blocking is defined as the desensitization of the receiver by a signal separated in frequency from the wanted signal by at least three channels. The signal frequencies that may block the receiver range from the lowest intermediate frequency of the receiver to at least three times the wanted signal frequency (f_c , see clause 4.2.2.5.2) of the receiver.

A **spurious response** is defined as the desensitization of the receiver by signals in a specific small band of frequencies which has a bandwidth (bs , see clause 4.2.2.5.2) of the same order as the channel bandwidth. The frequencies of signals that may produce spurious responses are in the same range as those that may cause blocking. The bandwidth (bs , see clause 4.2.2.5.2) of the spurious response is the continuous range of frequencies in which a signal at the level of the blocking level limit causes the error rate limit to be exceeded.

4.2.2.5.2 Limits

The unwanted signal level required to cause any spurious response shall not be lower than the limit value shown in table 9 and as depicted in figure 2.

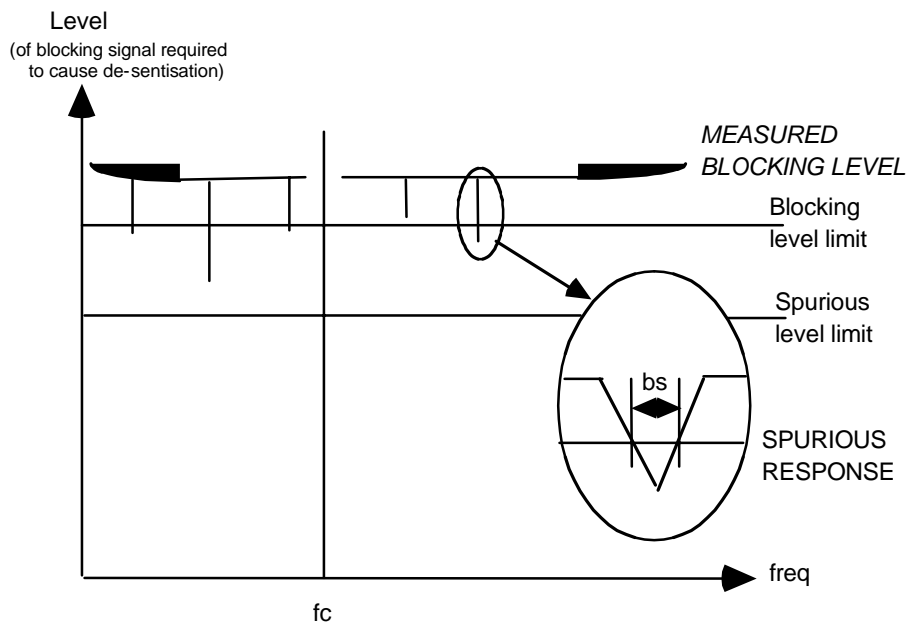

Figure 2: Blocking and spurious response limits

Table 9: Blocking and spurious response rejection

Frequency band	Desired signal (frequency f_c)	Blocking signal (frequency f_o)	Spurious response limit (frequency f_o)	Error rate (%)
$ f_c - f_o > 3$ MHz ($\pi/4$ DQPSK)	-102 dBm	-30 dBm	-45 dBm	3
3 MHz $> f_c - f_o > 90$ kHz ($\pi/4$ DQPSK)	-102 dBm	-45 dBm	-45 dBm	3
$ f_c - f_o > 3$ MHz (8 - PSK)	-99 dBm	-30 dBm	-45 dBm	3
3 MHz $> f_c - f_o > 90$ kHz (8 - PSK)	-99 dBm	-45 dBm	-45 dBm	3

Up to 12 in band and 24 out of band spurious responses are allowed.

The maximum bandwidth for any individual spurious response (bs) shall be 60 kHz up to the highest frequency in the operating band. At higher frequencies, the maximum bandwidth of an individual spurious response shall be 180 kHz. Responses having bandwidths greater than these limits shall be treated as multiple responses for the purpose of accumulating the response limit numbers.

4.2.2.5.3 Conformance

Conformance tests described in clause 5.4.1.4 shall be performed.

4.2.2.6 Adjacent and alternate channel desensitization

4.2.2.6.1 Definition

The adjacent channel selectivity and desensitization of a receiver is a measure of its ability to receive a modulated input signal on its assigned channel frequency in the presence of a second modulated input frequency spaced either one channel (30 kHz) above or one channel (30 kHz) below the assigned channel frequency.

The alternate channel selectivity and desensitization of a receiver is a measure of its ability to receive a modulated input signal on its assigned channel frequency in the presence of a second modulated input frequency spaced either two channels (60 kHz) above or two channels (60 kHz) below the assigned channel frequency.

4.2.2.6.2 Limits

The minimum adjacent-channel selectivity shall be 16 dB. The minimum alternate-channel selectivity shall be 60 dB.

4.2.2.6.3 Conformance

Conformance tests described in clause 5.4.1.5 shall be performed.

4.2.2.7 Receiver spurious emissions (idle mode)

4.2.2.7.1 Definition

The receiver conducted emissions are those out of band RF average power emissions measured at the UE antenna connector when the UE is in Idle Mode.

4.2.2.7.2 Limits

The limits shall be in accordance with the specifications of CEPT/ERC/REC 74-01 [12] (Recommendations 3, 4 and table 2.1 in annex 2):

- 57 dBm/100kHz for $30 \text{ MHz} \leq f \leq 1 \text{ GHz}$
- 47 dBm/1MHz for $1 \text{ GHz} < f \leq 12,75 \text{ GHz}$

4.2.2.7.3 Conformance

Conformance tests described in clause 5.4.1.6 shall be performed.

4.2.3 Conformance requirements (200kHz)

The 200 kHz channel provides packet data service and employs both eight level Phase Shift Keying (8-PSK) and GMSK (Gaussian Minimum Shift Keying) modulations.

4.2.3.1 Output RF spectrum

4.2.3.1.1 Definition

The output RF spectrum is the relationship between the frequency offset from the carrier and the power, measured in a specified bandwidth and time, produced by the UE due to the effects of modulation and power ramping.

4.2.3.1.2 Limits

4.2.3.1.2.1 Introduction

The specifications contained in this clause apply in frequency hopping as well as in non-frequency hopping modes.

Due to the bursty nature of the signal, the output RF spectrum results from two effects:

- the modulation process;
- the power ramping up and down (switching transients).

The limits specified are based on a 5-pole synchronously tuned measurement filter.

1. The level of the output RF spectrum due to GMSK and 8PSK modulations shall be no more than that given in clause 4.2.3.1.2.2, with the following lowest measurement limits:
 - -36 dBm at frequencies below 600 kHz offset from the carrier;
 - -56 dBm at frequencies from 600 kHz out to less than 1 800 kHz offset from the carrier;
 - -51 dBm at frequencies 1 800 kHz and beyond offset from the carrier;
 but with the following exceptions at up to -36 dBm:
 - up to three exceptions of 200 kHz width each, centred on a frequency which is an integer multiple of 200 kHz in the combined range 600 kHz to 6 000 kHz above and below the carrier;
 - up to 12 exceptions of 200 kHz width each, centred on a frequency which is an integer multiple of 200 kHz at more than 6 000 kHz offset from the carrier.
2. The level of the output RF spectrum due to switching transients shall be no more than given in 4.2.3.1.2.3;
3. The power emitted shall not exceed -71 dBm in frequency band 2 110 MHz to 2 170 MHz.

4.2.3.1.2.2 Spectrum due to the modulation and wide band noise

The output RF modulation spectrum is specified in tables 9 and 10. Masks representing this specification are shown in figures 3 and 4. This specification applies for all RF channels supported by the equipment.

The specification applies to the entire relevant transmit band and up to 2 MHz either side.

The limits shall be met under the following measurement conditions:

- zero frequency scan, filter bandwidth and video bandwidth of 30 kHz up to 1 800 kHz from the carrier and 100 kHz at 1 800 kHz and above from the carrier, with averaging done over 50 % to 90 % of the useful part of the transmitted bursts, excluding the midamble, and then averaged over at least 200 such burst measurements. Above 1 800 kHz from the carrier, only measurements centred on 200 kHz multiples are taken with averaging over 50 bursts;
- when tests are done in frequency hopping mode, the averaging shall include only bursts transmitted when the hopping carrier corresponds to the nominal carrier of the measurement. The limits then apply to the measurement results for any of the hopping frequencies.

The figures in table 10, at the vertically listed power level (dBm) and at the horizontally listed frequency offset from the carrier (kHz), are then the maximum allowed level (dB) relative to a measurement in 30 kHz on the carrier.

NOTE: This approach of specification has been chosen for convenience and speed of testing. It does however require careful interpretation if there is a need to convert figures in the following tables into spectral density values, in that only part of the power of the carrier is used as the relative reference, and in addition different measurement bandwidths are applied at different offsets from the carrier.

Table 10: Relative maximum level due to modulation

Carrier Power (dBm)	Frequency offset (kHz)							
	100	200	250	400	≥ 600 $< 1\,200$	$\geq 1\,200$ $< 1\,800$	1 800 $< 6\,000$	$\geq 6\,000$
≥ 33	+0.5	-30	-33	-60	-60	-60	-68	-76
32	+0.5	-30	-33	-60	-60	-60	-67	-75
30	+0.5	-30	-33	-60	-60 (see note)	-60	-65	-73
28	+0.5	-30	-33	-60	-6 (see note)	-60	-63	-71
26	+0.5	-30	-33	-60	-6 (see note)	-60	-61	-69
≤ 24	+0.5	-30	-33	-60	-6 (see note)	-60	-59	-67

NOTE: For equipment supporting 8-PSK, the requirement for 8-PSK modulation is -54 dB.

The following exceptions shall apply, using the same measurement conditions as specified above:

- a) in the combined range of 600 kHz to 6 MHz above and below the carrier, in up to three bands of 200 kHz width centred on a frequency which is an integer multiple of 200 kHz, exceptions levels of up to -36 dBm are allowed;
- b) above 6 MHz offset from the carrier in up to 12 bands of 200 kHz width centred on a frequency which is an integer multiple of 200 kHz, exceptions levels of up to -36 dBm are allowed.

Using the same measurement conditions as specified above, if a requirement in table 10 results in lower than the power limit given in table 11, then the latter shall be applied instead.

Table 11: Absolute maximum level due to modulation

Frequency offset from the carrier	Level
< 600 kHz	-36 dBm
≥ 600 kHz, $< 1\,800$ kHz	-56 dBm
$\geq 1\,800$ kHz	-51 dBm

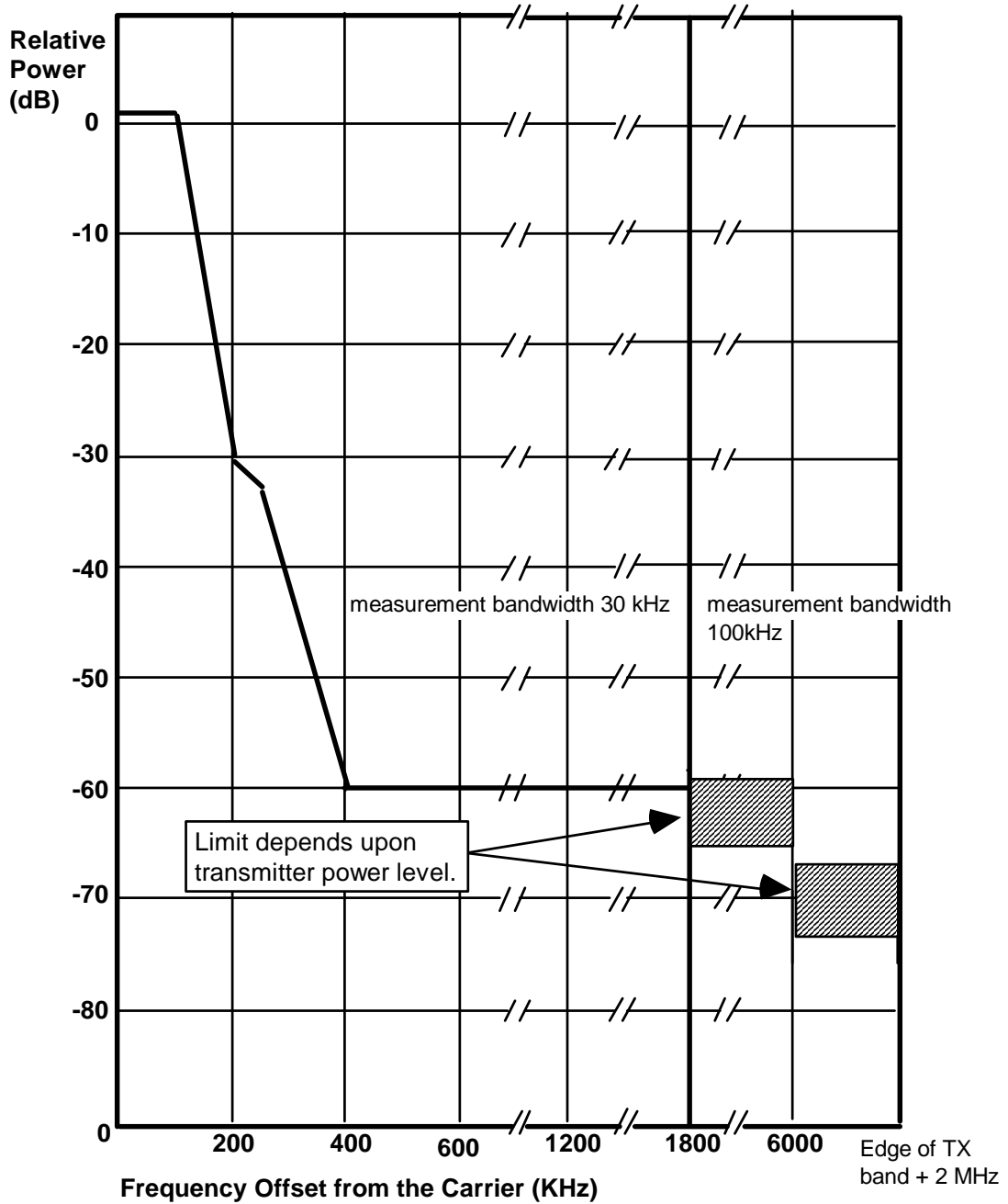

Figure 3: Modulation and Noise Spectrum Mask due to GMSK modulation

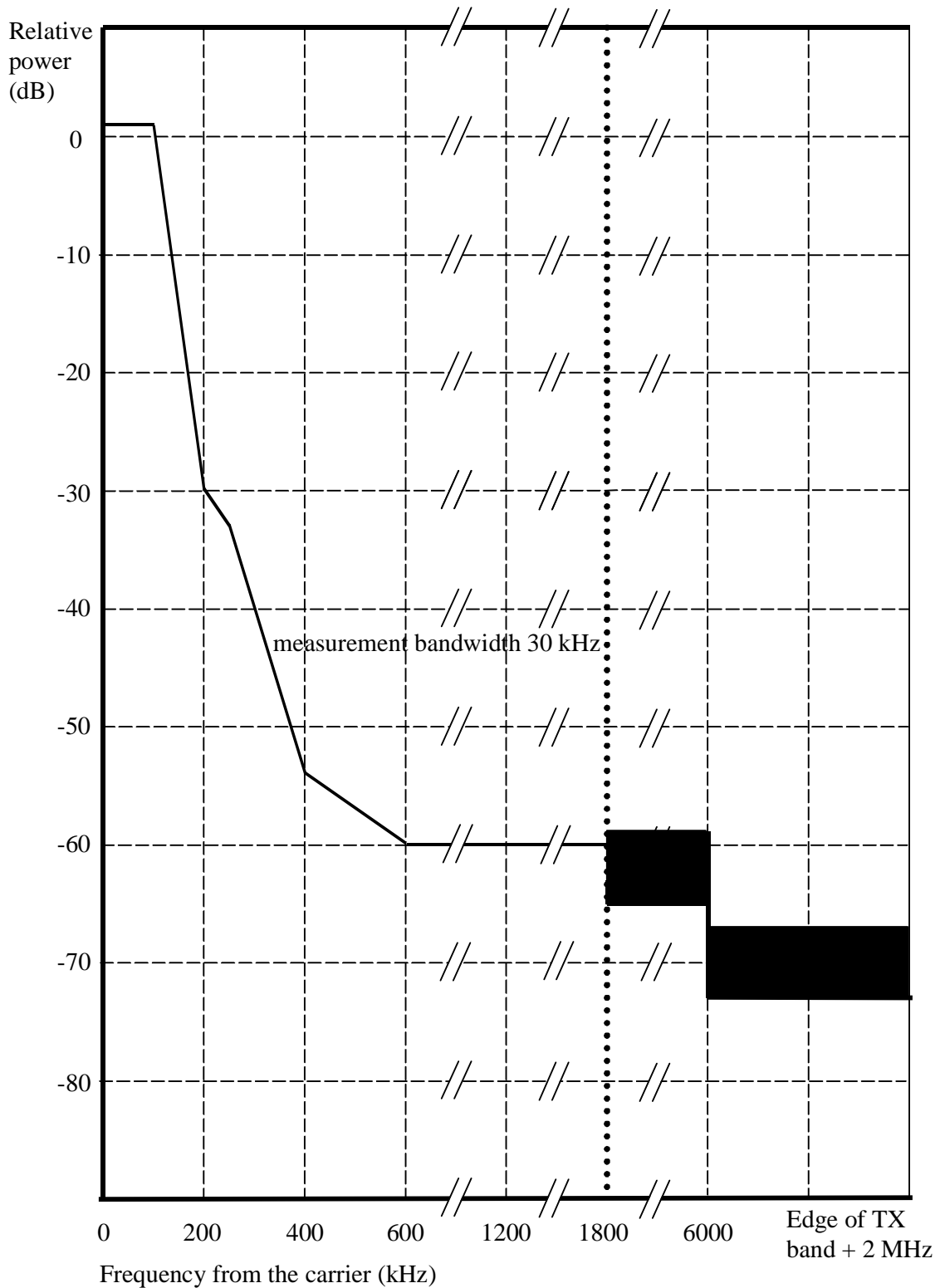

Figure 4: Modulation and noise spectrum mask due to 8-PSK modulation

4.2.3.1.2.3 Spectrum due to switching transients

These effects are also measured in the time domain and the specifications assume the following measurement conditions: zero frequency scan, filter bandwidth 30 kHz, peak hold, and video bandwidth 100 kHz. Table 12 specifies the limits. An example of a waveform due to a burst as seen in a 30 kHz filter offset from the carrier is shown in figure 5.

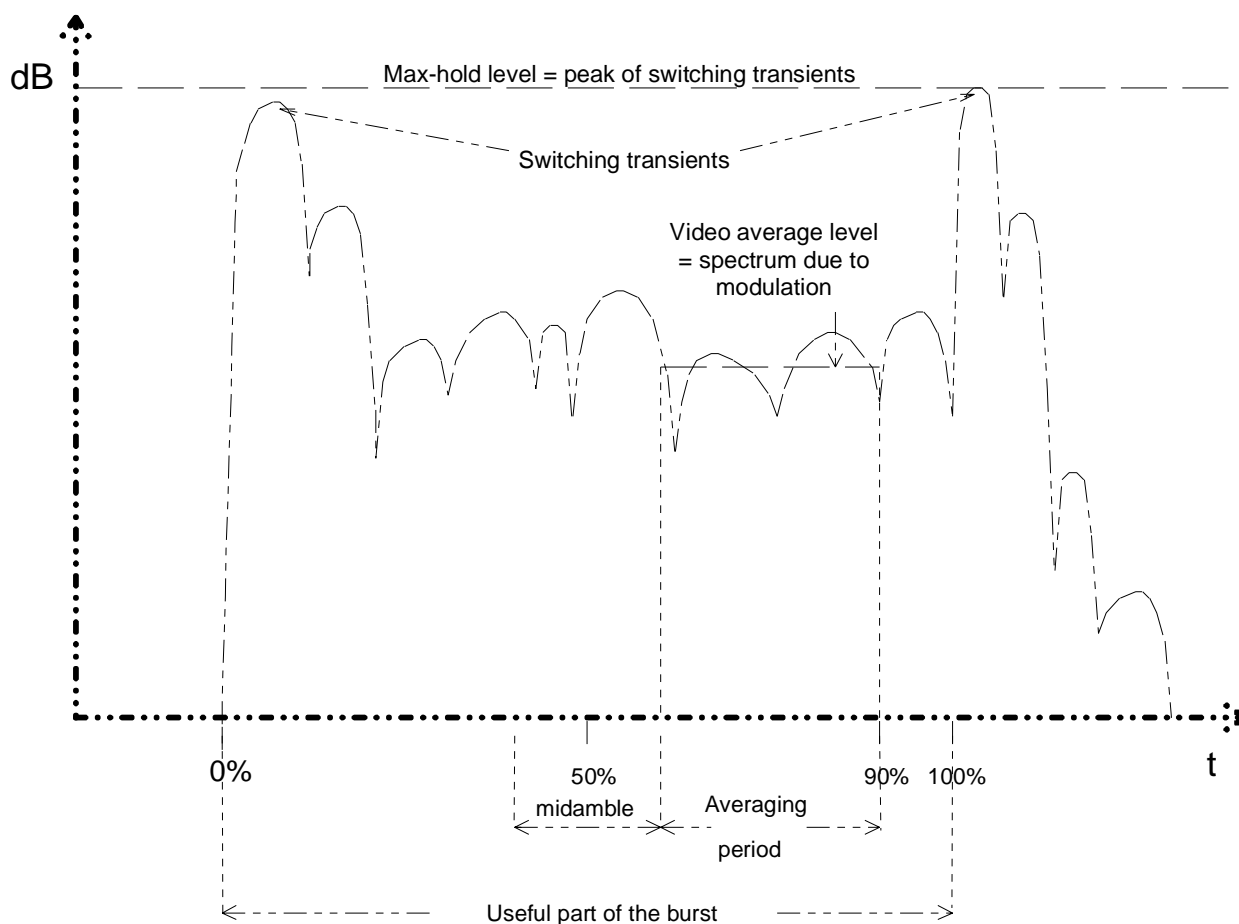

Figure 5: Example of a time waveform due to a burst as seen in a 30 kHz filter offset from the carrier

Table 12: Maximum levels due to switching transients

Carrier power level	Maximum level measured at various frequency offsets			
	400 kHz	600 kHz	1 200 kHz	1 800 kHz
39 dBm	-21 dBm	-26 dBm	-32 dBm	-36 dBm
≤ 37 dBm	-23 dBm	-26 dBm	-32 dBm	-36 dBm

NOTE 1: The relaxation for carrier power level 39 dBm is in line with the modulated spectra and thus causes negligible additional interference to an analogue system by a GSM signal.

NOTE 2: The near-far dynamics with this specification has been estimated to be approximately 58 dB for UE operating at a power level of 8 W or 49 dB for UE operating at a power level of 1 W. The near-far dynamics then gradually decreases by 2 dB per power level down to 32 dB for UE operating in cells with a maximum allowed output power of 20 mW or 29 dB for UE operating at 10 mW.

NOTE 3: The possible performance degradation due to switching transient leaking into the beginning or the end of a burst, was estimated and found to be acceptable with respect to the BER due to cochannel interference (C/I).

4.2.3.1.3 Conformance

Conformance tests described in clause 5.4.2.1 shall be performed.

4.2.3.2 Transmitter conducted spurious emissions

4.2.3.2.1 Definition

Conducted spurious emissions, when the UE is in packet transfer mode, are emissions from the antenna connector at frequencies other than those of the carrier and sidebands associated with normal modulation.

4.2.3.2.2 Limits

4.2.3.2.2.1 Spurious emissions, (Category B)

The power of any spurious emission shall not exceed the limits specified in table 13. This requirement is consistent with the recommendations of CEPT/ERC REC 74-01, annex 2 [12].

Table 13: UE mandatory spurious emission limits, Category B

Band (f) (see note 4)	Maximum level	Measurement bandwidth	Note
$9 \text{ kHz} \leq f \leq 150 \text{ kHz}$	-36 dBm	1 kHz	1
$150 \text{ kHz} < f \leq 30 \text{ MHz}$	-36 dBm	10 kHz	1
$30 \text{ MHz} < f \leq 1\,000 \text{ MHz}$	-36 dBm	100 kHz	1
$1\,000 \text{ MHz} < f < 1\,920 \text{ MHz}$	-30 dBm	1 MHz	1
$1\,920 \text{ MHz} \leq f \leq 1\,980 \text{ MHz}$	-36 dBm	100 kHz	2
$1\,980 \text{ MHz} < f < 2\,110 \text{ MHz}$	-30 dBm	1 MHz	1
$2\,110 \text{ MHz} \leq f \leq 2\,170 \text{ MHz}$	-66 dBm	100 kHz	3
$2\,170 \text{ MHz} < f \leq 12,75 \text{ GHz}$	-30 dBm	1 MHz	1

NOTE 1: In accordance with the applicable clauses of [13].
 NOTE 2: UE transmit band.
 NOTE 3: UE receive band.
 NOTE 4: f is the frequency of the spurious emission.

4.2.3.2.2.2 Co-existence with services in adjacent frequency bands

This requirement provides for the protection of receivers operating in bands adjacent to the UE transmit frequency band of 1 920 MHz to 1 980 MHz; GSM 400, GSM 900, R-GSM, UTRA-TDD.

NOTE: UTRA-FDD operates in the same frequency bands as UWC 136.

The power of any spurious emission shall not exceed the limits specified in table 14.

Table 14: Additional Spurious Emissions Requirements

Service	Frequency Band	Measurement Bandwidth	Minimum Requirement
GSM 450	$460,4 \leq f \leq 467,6 \text{ MHz}$	100 kHz	-67 dBm
GSM 480	$488,8 \leq f \leq 496,0 \text{ MHz}$	100 kHz	-67 dBm
R-GSM	$921 \text{ MHz} \leq f \leq 925 \text{ MHz}$	100 kHz	-60 dBm
R-GSM	$925 \text{ MHz} < f \leq 935 \text{ MHz}$	100 kHz	-67 dBm
GSM 900/R-GSM	$935 \text{ MHz} < f \leq 960 \text{ MHz}$	100 kHz	-79 dBm
DCS 1 800	$1\,805 \text{ MHz} \leq f \leq 1\,880 \text{ MHz}$	100 kHz	-71 dBm
UTRA TDD	$1\,900 \text{ MHz} \leq f \leq 1\,920 \text{ MHz}$	100 kHz	-62 dBm
UTRA TDD	$2\,010 \text{ MHz} \leq f \leq 2\,025 \text{ MHz}$	100 kHz	-62 dBm

NOTE: The measurements are made on frequencies which are integer multiples of 200 kHz. Up to five exceptions of up to -36dBm are permitted in the GSM 900, DCS 1 800 and UTRA bands, and up to three exceptions of up to -36dBm are permitted in the GSM 400 bands.

4.2.3.2.3 Conformance

Conformance tests described in clause 5.4.2.2 shall be performed.

4.2.3.3 Transmitter output power

4.2.3.3.1 Definition

The transmitter output power is the average value of the power delivered to an artificial antenna or radiated by the UE and its integral antenna, over the time that the useful information bits of one burst are transmitted.

4.2.3.3.2 Limits

1. For GMSK modulation the limits shown in table 15 shall apply.

Table 15: GMSK limits

Power class	Nominal maximum output power	Tolerance (dB) for conditions	
		normal	extreme
1	1 W (30 dBm)	± 2	$\pm 2,5$
2	0.25 W (24 dBm)	± 2	$\pm 2,5$
3	2 W (33 dBm)	± 2	$\pm 2,5$

NOTE: The lowest nominal output power for all classes is 0 dBm.

2. For 8-PSK modulation the limits shown in table 16 shall apply.

Table 16: 8-PSK limits

Power class	Nominal maximum output power	Tolerance (dB) for conditions	
		normal	extreme
E1	30 dBm	± 2	$\pm 2,5$
E2	26 dBm	-4 to +3	-4,5 to +4
E3	22 dBm	± 3	± 4

NOTE: The lowest nominal output power for all classes is 0 dBm.

3. Maximum output power for 8-PSK in any one band is always equal to or less than GMSK maximum output power for the same equipment in the same band.

A multi band UE has a combination of the power class in each band of operation from the table above. Any combination may be used.

4. The different power control levels needed for adaptive power control shall have the nominal output power as defined in table 17, starting from the power control level for the lowest nominal output power up to the power control level for the maximum nominal output power corresponding to the class of the particular UE as defined in the table above. Whenever a power control level commands the UE to use a nominal output power equal to or greater than the maximum nominal output power for the power class of the UE, the nominal output power transmitted shall be the maximum nominal output power for the UE class, and the tolerance specified for that class (see table above) shall apply.

Furthermore, the difference in output power actually transmitted by the UE between two power control levels where the difference in nominal output power indicates an increase of 2 dB (taking into account the restrictions due to power class), shall be $+2 \pm 1,5$ dB. Similarly, if the difference in output power actually transmitted by the UE between two power control levels where the difference in nominal output power indicates an decrease of 2 dB (taking into account the restrictions due to power class), shall be $-2 \pm 1,5$ dB.

Table 17: Power control levels

Power control level	Output power (dBm)	Tolerance (dB) for conditions	
		Normal	Extreme
22-29	Reserved	Reserved	Reserved
30	33	± 2 dB	$\pm 2,5$ dB
31	32	± 2 dB	$\pm 2,5$ dB
0	30	± 3 dB (see note)	± 4 dB (see note)
1	28	± 3 dB	± 4 dB
2	26	± 3 dB	± 4 dB
3	24	± 3 dB (see note)	± 4 dB (see note)
4	22	± 3 dB	± 4 dB
5	20	± 3 dB	± 4 dB
6	18	± 3 dB	± 4 dB
7	16	± 3 dB	± 4 dB
8	14	± 3 dB	± 4 dB
9	12	± 4 dB	± 5 dB
10	10	± 4 dB	± 5 dB
11	8	± 4 dB	± 5 dB
12	6	± 4 dB	± 5 dB
13	4	± 4 dB	± 5 dB
14	2	± 5 dB	± 6 dB
15	0	± 5 dB	± 6 dB
16 - 21	Reserved	Reserved	Reserved

NOTE: Tolerance for UE Power Classes 1 and 2 is ± 2 dB normal and $\pm 2,5$ dB extreme at Power Control Levels 0 and 3 respectively.

- For both GMSK and 8-PSK, the output power actually transmitted by the UE at each of the power control levels shall form a monotonic sequence, and the interval between power steps shall be $2 \text{ dB} \pm 1,5 \text{ dB}$ except for the step between power control levels 30 and 31 where the interval is $1 \text{ dB} \pm 1 \text{ dB}$.
- The transmitted power level relative to time for a normal burst shall be within the power/time template given in figure 6 for GMSK modulated signal. In multislot configurations where the bursts in two or more consecutive time slots are actually transmitted at the same frequency, no requirements are specified to the power ramping in the guard times between the active slots, and the template of figure 6 shall be respected at the beginning and the end of the series of consecutive bursts.

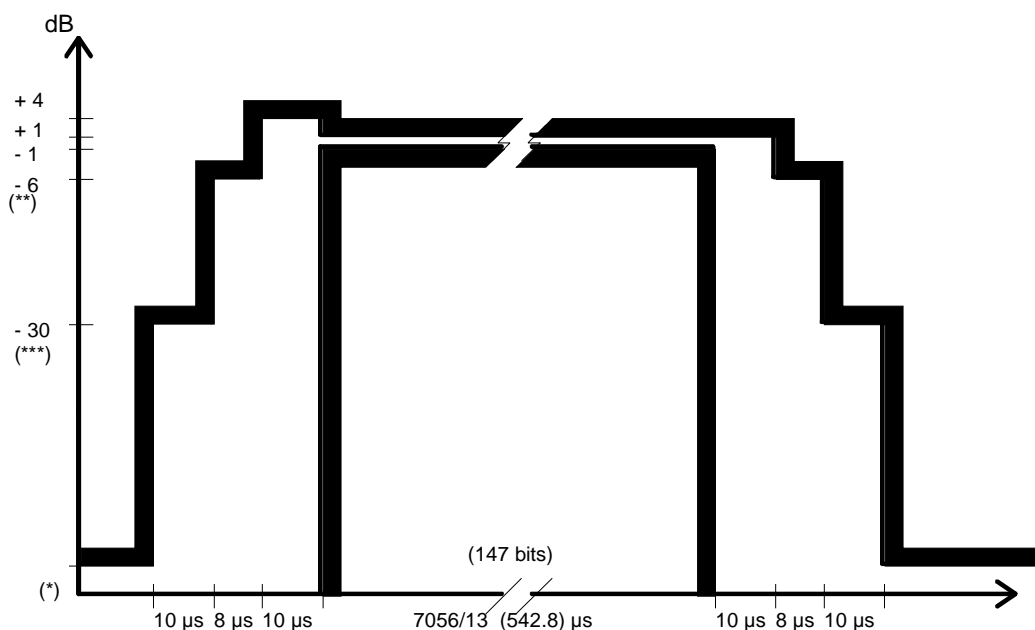

Figure 6: Time mask for normal duration bursts (NB, FB, dB and SB) at GMSK modulation

- The transmitted power level relative to time for a normal burst shall be within the power/time template given in figure 7 for 8 PSK modulated signal. In the case of Multislot Configurations where the bursts in two or more consecutive time slots are actually transmitted at the same frequency, the template of figure 7 shall be respected during the useful part of each burst and at the beginning and the end of the series of consecutive bursts. The output power during the guard period between every two consecutive active timeslots shall not exceed the level allowed for the useful part of the first timeslot, or the level allowed for the useful part of the second timeslot plus 3 dB, whichever is the highest.

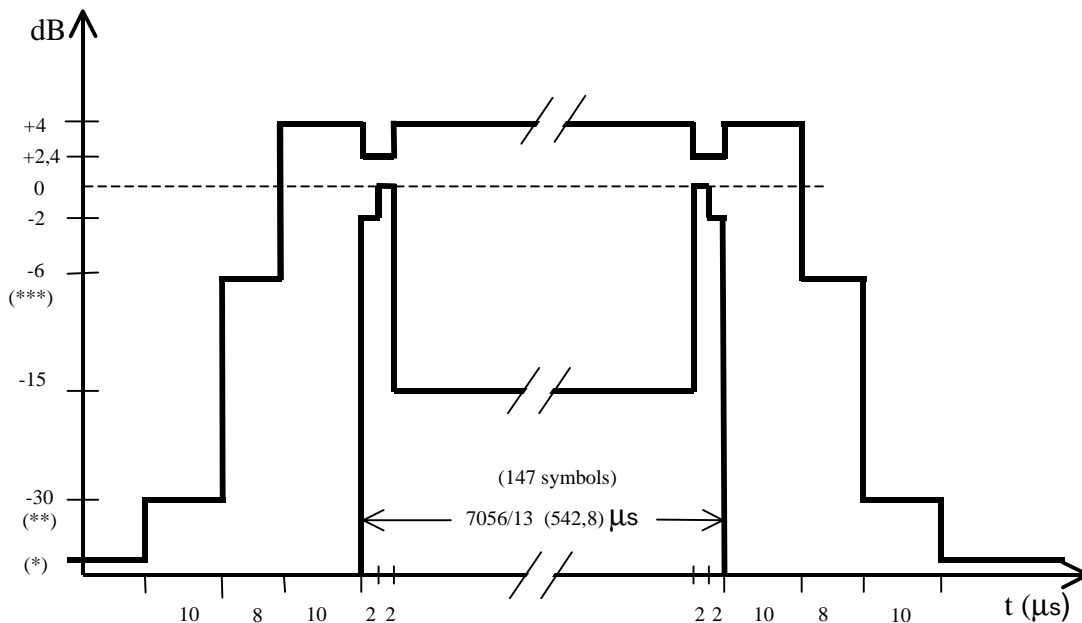

Figure 7: Time mask for normal duration bursts (NB) at 8-PSK modulation

- When accessing a cell on the PRACH or RACH (random access) and before receiving the first power control parameters during packet transfer on PDCH, the UE shall use the output power defined by P_{MAX}. MS_TXPWR_MAX_CCH is a parameter broadcast on the BCCH of the cell.
- The transmitted power level relative to time for a Random Access burst shall be within the power/time template given in figure 8:

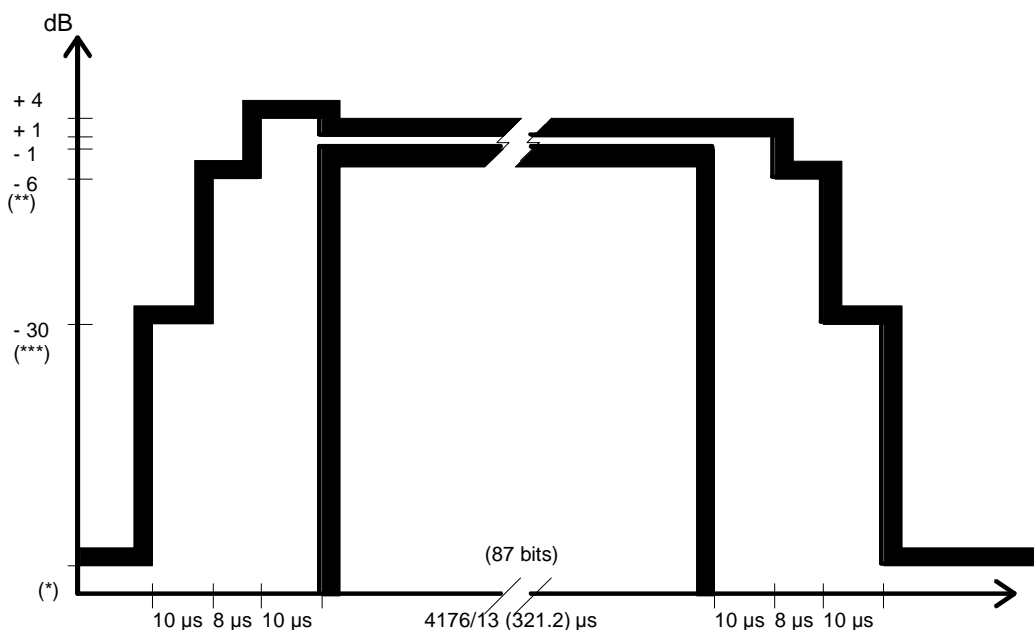

Figure 8: Time mask for access bursts (AB)

4.2.3.3.3 Conformance

Conformance tests described in clause 5.4.2.3 shall be performed.

4.2.3.4 Impact of interference on receiver performance

4.2.3.4.1 Introduction

The impact of interference on the receiver performance is characterized by these performance criteria:

- a) blocking characteristics;
- b) intermodulation characteristics.

4.2.3.4.2 Blocking and spurious response

4.2.3.4.2.1 Definition

Blocking is a measure of the ability of the receiver to receive a modulated wanted input signal in the presence of an unwanted input signal, on frequencies other than those of the spurious responses or the adjacent channels, without exceeding a given degradation. "Wanted signal" in this test is the signal generated by the transmitted RLC data blocks.

4.2.3.4.2.2 Limits

1. The blocking characteristics of the receiver are specified separately for in-band and out-of-band performance as defined in table 18.

Table 18: Definition of in-band and out-of-band

Frequency band	Frequency range (MHz)
out-of-band (a)	0,1 to <1 930
out-of-band (b)	1 930 to <2 110
in-band	2 110 to 2 170
out-of band (c)	>2 170 to 2 230
out-of band (d)	>2 230 to 12 750

2. The block error rate (BLER) performance for PDTCH/MCS1 to 4 shall not exceed 10 % and for PDTCH/MCS5 to 9 shall not exceed 10 % or 30 % depending on Coding Schemes and for USF/MCS1 to 9 shall not exceed 1 % when the following signals are simultaneously input to the receiver:

- a useful signal at frequency f_0 , 3 dB above the reference sensitivity level specified in clause B.3 for the appropriate modulation and channel type: GMSK and 8-PSK modulation;
- a continuous, static sine wave unwanted signal at a level as in the table 19 and at a frequency (f) which is an integer multiple of 200 kHz.

with the following exceptions, called spurious response frequencies:

- a) in band, for a maximum of twelve occurrences (which if grouped shall not exceed three contiguous occurrences per group);
- b) out of band, for a maximum of 24 occurrences (which if below f_0 and grouped shall not exceed three contiguous occurrences per group).

where the above performance shall be met when the continuous sine wave signal (f) is set to a level of 70 dB μ V (emf) (i.e. -43 dBm).

Table 19: CW blocking signal limits

Frequency offset band	dB μ V (emf)	DBm
in-band		
600 kHz $\leq f - f_0 < 800$ kHz	70	-43
800 kHz $\leq f - f_0 < 1,6$ MHz	70	-43
1,6 MHz $\leq f - f_0 < 3$ MHz	80	-33
3 MHz $\leq f - f_0 $	87	-26
out-of-band		
(a)	113	0
(b)	101	-12
(c)	101	-12
(d)	113	0

4.2.3.4.2.3 Conformance

Conformance tests described in clause 5.4.2.4.1 shall be performed.

4.2.3.4.3 Intermodulation rejection

4.2.3.4.3.1 Definition

The intermodulation rejection characteristic of a receiver is a measure of its ability to receive a wanted modulated signal without exceeding a given performance degradation due to the presence of two or more unwanted signals with a specific frequency relationship to the wanted signal frequency. "Wanted signal" in this test is the signal generated by the transmitted RLC data blocks.

4.2.3.4.3.2 Limits

In the presence of two unwanted signals with a specific frequency relationship to the wanted signal frequency in both GMSK and 8-PSK modulations:

1. The block error rate (BLER) performance for PDTCH/MCS1 to 4 shall not exceed 10 % and for PDTCH/MCS5 to 9 shall not exceed 10 % or 30 % depending on the Coding Scheme.
2. The block error rate (BLER) performance for USF/MSC-1 to 9 shall not exceed 1 %.

4.2.3.4.3.3 Conformance

Conformance tests described in clause 5.4.2.4.2 shall be performed.

4.2.3.5 Co-channel rejection

4.2.3.5.1 Definition

The co-channel rejection is a measure of the capability of the receiver to receive a wanted modulated signal without exceeding a given degradation due to the presence of an unwanted modulated signal, both signals being at the nominal frequency of the receiver. "Wanted signal" in this test is the signal generated by the transmitted RLC data blocks.

4.2.3.5.2 Limits

1. The block error rate (BLER) performance for PDTCH/MCS1 to 4 shall not exceed 10 % at co-channel interference ratios (C/I_c) exceeding those according to the table 24a; and for PDTCH/MCS5 to 9 shall not exceed 10 % or 30 % depending on Coding Schemes at co-channel interference ratios (C/I_c) exceeding those according to the table 20.

Table 20: PDTCH Co-channel Interference Ratio for GMSK modulation

Type of Channel		Propagation conditions			RA (no FH)
		TU low (no FH)	TUhigh (no FH)	TUhigh (ideal FH)	
PDTCH/MCS-1	dB	13	10	9,5	10
PDTCH/MCS-2	dB	15	12	12	12
PDTCH/MCS-3	dB	16,5	17	18	19
PDTCH/MCS-4	dB	19	23	23	(see note)

NOTE: PDTCH/MCS-4 cannot meet the reference performance for some propagation condition.

Table 21: Co-channel interference ratio at reference performance for 8-PSK modulation

Type of channel		Propagation conditions			RA (no FH)
		TU low (no FH)	TUhigh (no FH)	TUhigh (ideal FH)	
PDTCH/MCS-5	dB	19,5	15	15,5	16,5
PDTCH/MCS-6	dB	21,5	18	18,5	21
PDTCH/MCS-7	dB	26,5	27,5	28	(see note 1)
PDTCH/MCS-8	dB	30,5	29,5	29	(see note 1)
PDTCH/MCS-9	dB	25,5 (see note 2)	(see note 1)	(see note 1)	(see note 1)

NOTE 1: PDTCH/MCS-x cannot meet the reference performance for some propagation condition.
NOTE 2: Performance is specified at 30 % BLER for some cases.

2. The block error rate (BLER) performance for USF/MCS1 to 9 shall not exceed 1 % at co-channel interference ratios (C/I_c) exceeding those according to the tables 22 and 23.

Table 22: USF Co-channel Interference Ratio for GMSK modulation

Type of channel		Propagation conditions			RA (no FH)
		TU low (no FH)	TUhigh (no FH)	TUhigh (ideal FH)	
USF/MCS-1 to 4	dB	18	9,5	9,5	9,5

Table 23: USF Co-channel Interference Ratio for 8-PSK modulation

Type of Channel		Propagation conditions			RA (no FH)
		TU low (no FH)	TUhigh (no FH)	TUhigh (ideal FH)	
USF/MCS-5 to 9	dB	17	10	9	9

4.2.3.5.3 Conformance

Conformance tests described in clause 5.4.2.5 shall be performed.

4.2.3.6 Receiver adjacent channel selectivity

4.2.3.6.1 Definition

The receiver adjacent channel selectivity is a measure of the capability of the receiver to receive wanted data packets without exceeding a given degradation due to the presence of an interfering signal (I1) in the adjacent channel. "Wanted signal" in this test is the signal generated by the transmitted RLC data blocks.

4.2.3.6.2 Limits

1. For GMSK modulation, under adjacent channel interference at 200 kHz above and below the wanted signal frequency and at the adjacent interference ratio (C/I_{a1}) exceeding $C/I_c - 18$ dB where C/I_c is the co-channel interference ratio specified in table 22 for PDTCH and table 23 for USF channels.
 - 1.1 For a TUhigh faded wanted signal and a TUhigh adjacent channel interferer, the block error rate (BLER) performance for PDTCH/MCS-1 to 4 shall not exceed 10 %.
 - 1.2 For a TUhigh faded wanted signal and a TUhigh adjacent channel interferer, the block error rate (BLER) performance for USF/MS-1 to 4 shall not exceed 1 %.
- For 8-PSK modulation, under adjacent channel interference at 200 kHz above and below the wanted signal frequency and at the adjacent interference ratio (C/I_{a1}) specified in table 24.
- 1.3 For a TUhigh faded wanted signal and a TUhigh adjacent channel interferer, the block error rate (BLER) performance for PDTCH/MCS-5 to 9 shall not exceed 10 % or 30 % depending on Coding Scheme.
- 1.4 For a TUhigh faded wanted signal and a TUhigh adjacent channel interferer, the block error rate (BLER) performance for USF/MS-5 to 9 shall not exceed 1 %.

Table 24: Adjacent channel interference ratio for UE at reference performance for 8-PSK modulation

Type of channel		Propagation conditions				RA (no FH)
		TU low (no FH)	TU low (ideal FH)	TUhigh (no FH)	TUhigh (ideal FH)	
PDTCH/MCS-5	dB	2,5	-2	-2	-1,5	1
PDTCH/MCS-6	dB	5,5	0,5	1,5	1,5	6,5
PDTCH/MCS-7	dB	10,5	8	12,5	12	(see note 1)
PDTCH/MCS-8	dB	15,5	9	16	15,5	(see note 1)
			(see note 2)	(see note 2)	(see note 2)	
PDTCH/MCS-9	dB	10 (see note 2)	12,5 (see note 2)	*	*	(see note 1)
USF/MCS-5 to 9	dB	-1	-8,5	-9	-9,5	-9

NOTE 1: PDTCH for MCS-x cannot meet the reference performance for some propagation conditions.
NOTE 2: Performance is specified at 30 % BLER for some cases.

2. For both GMSK and 8-PSK modulations, under adjacent channel interference conditions with interfering signals at 400 kHz above and below the wanted signal frequency and at the adjacent interference ratio (C/I_{a2}) exceeding $C/I_c - 50$ dB
 - 2.1 For a TUhigh faded wanted signal and a TUhigh adjacent channel interferer, the block error rate (BLER) performance for PDTCH/MCS-1 to 4 shall not exceed 10 % for GMSK modulation; and for PDTCH/MCS-5 to 9 shall not exceed 10 % or 30 % depending on Coding Schemes.
 - 2.2 For a TUhigh faded wanted signal and a TUhigh adjacent channel interferer, the block error rate (BLER) performance for USF/MS-1 to 9 shall not exceed 1 %.

C/I_c is the co-channel interference ratio. For a PDTCH with GMSK modulation C/I_c is specified in table 20; for a PDTCH with 8-PSK modulation C/I_c is specified in table 21, for a USF with GMSK modulation C/I_c is specified in tables 22; and for USF with 8-PSK modulation C/I_c is specified in table 23.

4.2.3.6.3 Conformance

Conformance tests described in clause 5.4.2.6 shall be performed.

4.2.3.7 Receiver spurious emissions (idle mode)

4.2.3.7.1 Definition

The receiver conducted emissions are those out of band RF average power emissions measured at the UE antenna connector when the UE is in Idle Mode.

4.2.3.7.2 Limits

The limits shall be in accordance with the specifications of CEPT/ERC/REC 74-01 (Recommendations 3, 4 and table 2.1 in annex 2):

- 57 dBm/100kHz for $30 \text{ MHz} \leq f \leq 1 \text{ GHz}$
 -47 dBm/1MHz for $1 \text{ GHz} < f \leq 12,75 \text{ GHz}$

4.2.3.7.3 Conformance

Conformance tests described in clause 5.4.2.7 shall be performed.

5 Testing for compliance with technical requirements

5.1 Environmental conditions for testing

Tests defined in the present document shall be carried out at representative points within the boundary limits of the declared operational environmental profile.

Where technical performance varies subject to environmental conditions, tests shall be carried out under a sufficient variety of environmental conditions (within the boundary limits of the declared operational environmental profile) to give confidence of compliance for the affected technical requirements.

Normally it should be sufficient for all tests to be conducted using normal test condition (see clause 5.2.2) except where otherwise stated. For guidance on the use of other test conditions to be used in order to show compliance reference can be made to TS 151 010 [14].

5.2 Test conditions

5.2.1 Standard test equipment (30 kHz)

5.2.1.1 Standard test source

The Standard Test Source shall consist of a configuration of test equipment complying with the following requirements:

- a) It shall be tunable over the applicable range of radio frequencies;
- b) It shall be capable of generating $\pi/4$ DQPSK modulation corresponding to a serial input data stream and associated data clock. The clock frequency shall be nominally 48,6 kHz for $\pi/4$ DQPSK. The output waveform shall have an RMS error vector magnitude of no greater than 3,2 % and conform to the requirements of TIA/EIA-136-270 [5]. It shall be capable of generating 8-PSK modulation corresponding to a serial input data stream and associated data clock. The clock frequency shall be nominally 72,9 kHz for 8-PSK. The output waveform shall have an RMS error vector magnitude of no greater than 3,2 % and conform to the requirements of TIA/EIA-136-270 [5];
- c) It shall be capable of generating signal levels from -120 dBm to -15 dBm. It shall have an accuracy of $\pm 1,5$ dB up to 2 000 MHz;
- d) It shall have an output impedance of 50 Ω , with a maximum SWR of 1,5 / 1 over the range specified in (a);
- e) It shall be capable of generating a static channel without Rayleigh fading and without dispersion;
- f) It shall have a frequency resolution of 10 Hz;
- g) It shall have an amplitude resolution of 0,1 dB;
- h) It shall maintain frequency stability of $\pm 0,10$ ppm;

- i) It shall have adequate noise performance to perform adjacent and alternate channel measurements.

5.2.1.2 Standard test receiver

The standard test receiver shall consist of a configuration of test equipment complying with the following minimum requirements:

- a) It shall be tunable over the applicable range of radio frequencies and shall have a nominal input impedance of 50 Ω ;
- b) It shall be capable of demodulating a $\pi/4$ DQPSK modulated signal, recovering the associated data clock and providing the serial data stream at the output. Its BER, when demodulating a signal that conforms to the modulation accuracy specifications in TIA/EIA-136-131 [4] and having a carrier to noise ratio of at least 60 dB shall be no greater than 0,01 %. It shall be capable of demodulating an 8-PSK modulated signal, recovering the associated data clock and providing the serial data stream at the output. Its BER, when demodulating a signal that conforms to the modulation accuracy specifications in TIA/EIA-136-131 [4] and having a carrier to noise ratio of at least 60 dB shall be no greater than 0,01 %;
- c) It shall be capable of recovering data from a UE with 15 % error vector magnitude with BER no greater than 0,1 %;
- d) It shall be capable of demodulating signals over a 51 dB range;
- e) It shall be capable of demodulating signals with origin offsets < -20 dBc;
- f) It shall be capable of demodulating signals with frequency offsets of ± 1 kHz.

5.2.1.3 Spectrum analyser or measuring receiver

The spectrum analyser or measuring receiver shall have the following characteristics:

- a) It shall be capable of measuring signals with levels from -90 dBm to +20 dBm over the applicable range of frequencies;
- b) It shall have a dynamic range of at least 70 dB with a log fidelity accuracy of ± 1 dB over this range;
- c) It shall have a relative frequency response of ± 1 dB over the frequency range of 10 MHz to 6 000 MHz;
- d) It shall have synchronously tuned or Gaussian intermediate frequency filters of at least 3 poles with selectable bandwidths of 300 kHz, 30 kHz, 3 kHz and 1 kHz or narrower;
- e) It shall have post detection video filtering bandwidths selectable in decade steps from 100 Hz to 1 MHz;
- f) It shall provide the choice of peak and sample detection;
- g) It shall have peak hold and video average functions;
- h) It shall be capable of measuring the mean power of a modulated signal, using a passband equivalent to an ideal root raised-cosine receiver filter. The mean power measurement of a signal modulated with pseudo random data shall be within $\pm 0,5$ dB of the measurement of an unmodulated signal of the same power using the peak detector.

5.2.1.4 Modulation accuracy measurement equipment

The modulation accuracy measurement equipment shall consist of a configuration of test equipment complying with the following minimum requirements:

- a) It shall be tunable over the applicable range of radio frequencies;
- b) It shall be capable of measuring RMS error vector magnitude as specified in section 3.3.2 of TIA/EIA-136-270 [5] of with the following accuracies and residuals:
 - 1) Accuracy: greater of residual or 5 % of reading;
 - 2) Residual: 0,5 %.

- c) It should be capable of demodulating signals from -18 to +39 dBm;
- d) It shall be capable of measuring origin offset as specified in section 3.3.2 of TIA/EIA-136-270 [5] with an accuracy of ± 1 dB;
- e) It shall be capable of resolving frequency offsets averaged over a burst to ± 10 Hz.

5.2.1.5 Standard BER/WER test equipment

- a) Data Generation: It shall be capable of generating a pseudo-random bit stream that is interleaved and built into time slots in accordance with TIA/EIA-136-131 [4] (DTC) and TIA/EIA-136-121 [6] (DCCH);
- b) Data Reception: It shall be capable of receiving the data in time slot format. Data from the user part of the DTC, BCCH and RACH will be de-interleaved for comparison to the original pseudo-random bit stream;
- c) BER shall be measured up to rates of 40 %;
- d) WER shall be measured up to rates of 100 % provided BER is less than 40 %.

5.2.1.6 Standard Protocol Test Equipment

The Standard Protocol Test Equipment shall have the necessary signalling and protocol capability to perform:

- a) Call origination and UE paging;
- b) Handoffs within digital or analogue modes and across mode boundaries;
- c) Time alignment tests;
- d) Mobile Assisted Handoff tests

5.2.1.7 Standard Channel Simulator

Measurements requiring the Standard Channel Simulator will be performed at Channel 1 000 at a nominal UE receive centre frequency of 1 960,020 MHz and a nominal base station receive centre frequency of 1 879,980 MHz.

The maximum Doppler frequency referred to in this clause is a function of the receive centre frequency of the unit under test and the simulated vehicle speed, as follows:

$$f_d = \left(\frac{v}{c} \right) f_c$$

where v is simulated vehicle speed, c is $2,997925 \times 10^8 \text{ ms}^{-1}$, the speed of light in vacuum, and f_c is 1 960,020 MHz for UE testing and 1 879,980 MHz for base station testing. Table 25 gives the corresponding values of v and f_d .

Table 25: Vehicular speed and Doppler frequency

Vehicle Speed in km/h	UE f_d in Hz	BS f_d in Hz
8	14,529	13,935
50	90,804	87,096
100	181,609	174,193

The Standard Channel Simulator shall at a minimum be capable of the following:

- a) RF input and output centre frequencies between 1 850 MHz to 1 910 MHz and 1 930 MHz to 1 990 MHz;
- b) Simulate a flat fading channel for simulated vehicle speeds varying from 8 to 100 km/h. Specifically for 8 km/h, 50 km/h, and 100 km/h (nominally 5 mph, 30 mph and 60 mph);
- c) Simulate two rays with independent fading statistics. Each Rayleigh faded ray shall have a time delay of up to 1 symbol (41,6 ms) with delay resolution of 0,1 ms;

- d) Have sufficient bandwidth to accommodate co-channel and adjacent channel measurements. The passband characteristics of the channel simulator shall not degrade the modulated signal, as specified in section 3.3.2 of TIA/EIA-136-270 [5].

Generation of the Rayleigh fading conditions shall conform to the following (all measurements shall hold for simulated vehicle speeds of 8 km/h and 100 km/h upon an unmodulated carrier):

- a) The measured Rayleigh Cumulative Probability Distribution Function (CPDF) shall be compared against a calculated CPDF:

For $P < 0$: $F(P) > 0$; For $P = 0$: $F(P) = 1 - \exp\{-P/P_{ave}\}$, where P is the signal power level and P_{ave} is the mean power level.

- 1) Measured CPDF of Power shall be within ± 1 dB of the calculated CPDF of Power from 10 dB above the mean power level to 20 dB below the mean power level;
 - 2) Measured CPDF of Power shall be within ± 5 dB of the calculated CPDF of Power from 20 dB below the mean power level to 30 dB below the mean power level.
- b) The Level Crossing Rate (LCR) shall be compared against a calculated LCR. The calculated Rayleigh level crossing rate, $L(P)$, is as follows:

For $P < 0$: $L(P) = 0$; For $P = 0$: $L(P) = (2P/P_{ave})^{0.5} f_d \exp\{-P/P_{ave}\}$, where P is the signal power level, P_{ave} is the mean power level, and f_d is the Doppler frequency offset associated with the simulated vehicle speed.

- 1) The measured LCR curve shall not deviate from the calculated LCR curve by more than 5% of the simulated vehicle speed. This shall hold for 10 dB above the mean power level to 30 dB below the mean power level.
- c) The measured power spectral density, $S(f)$, shall meet the requirements specified below. The power spectrum measurement shall be made on an unmodulated carrier (at frequency f_c) applied to the input of the channel simulator.
- 1) The maximum power spectral density level, S_{max} , shall exceed $S(f_c)$ by at least 6 dB;
 - 2) The simulated Doppler frequency offset, f_d , shall be within $\pm 5\%$ of the theoretical Doppler frequency offset associated with the vehicle speed. The simulated Doppler frequency offset shall be calculated from the measured power spectral density as follows:

$$f_d = (1/2\pi)(2b_2/b_0)^{0.5},$$

$$\text{where: } b_n = (2\pi)^n \int_0^{\infty} S(f)(f-f_c)^n df$$

b_n is the n^{th} moment of $S(f)$.

- 3) $S(f)$ shall be at least 30 dB below $S(f_c)$ for $|f - f_c| > 2f_d$.

The correlation coefficient of the unwrapped phase of the emulated, received signal shall be compared against the calculated theoretical correlation coefficient of the phase of a Rayleigh faded signal. The theoretical correlation coefficient, is well approximated by:

$$\rho(\tau) \approx \frac{3}{2\pi} \sin^{-1}(h(\tau)) + 6 \frac{1}{2\pi} \sin^{-1}(h(\tau))^2 - \frac{3}{4\pi^2} \sum_{n=1}^{\infty} \frac{h(\tau)^{2n}}{n^2}$$

where:

$$h(\tau) = J_0(2\pi f_d \tau) * \frac{\sin(2\pi f_d \tau)}{(2\pi f_d \tau)}$$

and * is the convolution function.

- 4) The measured correlation coefficient of the phase shall be $0,8 \pm 0,1$ at a lag of $0,05/f_d$, and $0,5 \pm 0,1$ at a lag of $0,15/f_d$. The theoretical curve is shown in figure 5.

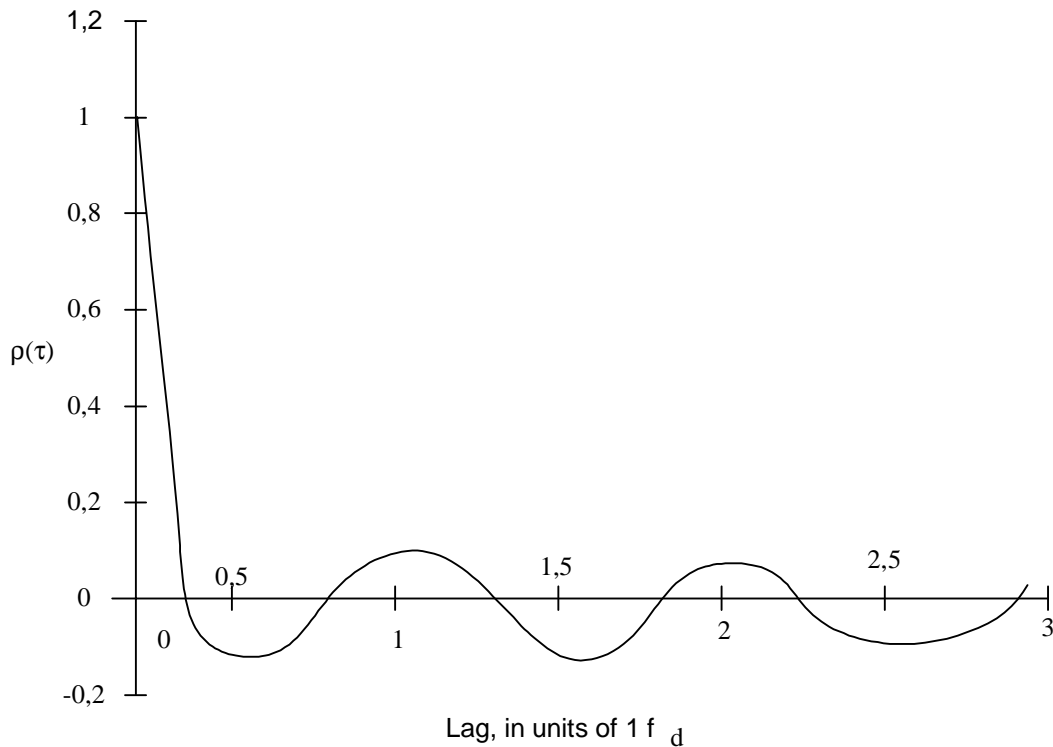

Figure 5: Theoretical correlation coefficient

5.2.2 Standard test environment

Pressure	± 5 kPa
Temperature	± 2 degrees
Relative Humidity	± 5 %
DC Voltage	$\pm 1,0$ %
AC Voltage	$\pm 1,5$ %
Vibration	10 %
Vibration frequency	0,1 Hz

The above values shall apply unless the test environment is controlled and the specification for the control of the test environment specifies the uncertainty for the parameter.

5.3 Interpretation of the test results

5.3.1 Measurement uncertainties

The maximum acceptable uncertainty of measurement equipment is specified separately for each test, where appropriate. The measurement equipment shall enable the stimulus signals in the test case to be adjusted to within the specified tolerance, and the conformance requirement to be measured with an uncertainty not exceeding the specified values. All tolerances and uncertainties are absolute values, unless otherwise stated.

For the test methods, according to the present document, the measurement uncertainty figures shall be calculated in accordance with ETR 028 [10] and shall correspond to an expansion factor (coverage factor) $k = 1,96$ or $k = 2$ (which provide confidence levels of respectively 95 % and 95,45 % in the case where the distributions characterizing the actual measurement uncertainties are normal (Gaussian). Table 26 is a summary of all measurement uncertainties.

Table 26: Measurement uncertainty values for the essential tests

Test	Parameter	Conditions	Uncertainty	
Emission mask	RF power, absolute	-	±1,0 dB	
	RF power, relative	Offset from carrier, (MHz)	Power difference (dB)	-
		$\Delta f \leq 0,1$ MHz	All	±0,5 dB
		0.1 MHz < $\Delta f \leq 1,8$ MHz	<50 dB	±0,7 dB
		0.1 MHz < $\Delta f \leq 1,8$ MHz	≥50 dB	±1,5 dB
$\Delta f > 1,8$ MHz	All	±2,0 dB		
Transmitter conducted spurious emissions	RF power	In the TX band	±1,5 dB	
		In the RX band	±3 dB	
		$f \leq 2$ GHz	±1,5 dB	
		2 GHz < $f \leq 4$ GHz	±2,0 dB	
		$f > 4$ GHz	±4,0 dB	
RF power output	Carrier power	Static	±1,0 dB	
		Relative power steps	±0,7 dB	
	Carrier power versus time	RF power (0 dB reference)	±1,0 dB	
		RF power relative to 0 dB reference	±1,0 dB	
Transmitter intermodulation spurious emissions	Relative RF power	Injected signal	±1,5 dB	
		Outside the RX band, absolute limits	±1,5 dB	
		Outside the RX band, relative measurements	±2,0 dB	
		Inside the RX band, absolute limits	+4 dB to -3 dB	
Receiver intermodulation spurious response	Relative RF power	Inside the RX band, absolute limits	±3,0 dB	
Receiver adjacent and alternate channel desensitization	RF power	Static reference sensitivity	±1,0 dB	
		Sensitivity, adjacent timeslots	±3,0 dB	
Receiver blocking characteristics	RF power	Wanted signal	±1,0 dB	
		Interfering signal, $f \leq 2$ GHz	±0,7 dB	
		Interfering signal, 2 GHz < $f \leq 4$ GHz	±1,5 dB	
		$f > 4$ GHz	±3,0 dB	
Adjacent channel selectivity	Relative RF power		±1,0 dB	

NOTE: Where a measurement uncertainty of +X dB -0 dB is specified for an input signal, the measured value of the input signal should be increased by an amount equal to the uncertainty with which it can be measured. This will ensure that the true value of the input signal is not below the specified nominal.

5.3.2 Interpretation of the measurement results

The interpretation of the results recorded in a test report for the measurements described in the present document shall be as follows:

The measurement value related to the corresponding limit shall be used to decide whether an equipment meets a requirement in the present document.

The measurement uncertainty for the measurement of each parameter shall be included in the test report.

The recorded value for the measurement uncertainty shall be, for each measurement, equal to or lower than the appropriate value in table 26.

NOTE: The following procedure is recommended in ETR 028 [10].

If the measurement apparatus for a test is known to have a measurement uncertainty greater than that specified in table 26, it is still permitted to use this apparatus provided that an adjustment is made to the measured value as follows:

- the adjustment is made by subtracting the modulus of the specified measurement uncertainty from the measurement uncertainty of the apparatus. The measured value is then increased or decreased by the result of the subtraction, whichever is most unfavourable in relation to the limit.

For the 30 kHz channel measurements, the following shall also apply:

- the value of the measurement uncertainty or the accuracy of each piece of test equipment used for the measurement of each parameter shall be included in the test report; only test equipment meeting the performance requirements for standard test equipment as defined in clause 5.2.1, shall be used;
- the recorded value of the accuracy of each piece of test equipment shall be equal to or better than the figures in clause 5.2.1;
- the recorded value of the measurement uncertainty shall be, for each measurement, equal to or lower than the figures in table 26.

5.4 Essential radio test suites

5.4.1 Essential radio test suites (30 kHz)

5.4.1.1 Spectrum emissions mask

5.4.1.1.1 Adjacent and alternate channel power due to modulation

Modulate the UE transmitter on a Traffic Channel with pseudo-random data field bits. Filler code will be transmitted on the SACCH. DVCC shall be set to binary 1. The output of the transmitter will be on only during the time slots corresponding to the Traffic Channel. Using a spectrum analyser or measuring receiver tuned to the transmitter nominal carrier frequency, obtain the mean output power as a reference.

Measure the emission power at frequency offsets of ± 30 kHz (adjacent channel), ± 60 kHz (alternate channel), and ± 90 kHz. Frequency offset is the separation between the nominal carrier frequency of the transmitter and the centre of the bandwidth within which the measurement is made.

The analyser or receiver shall make average power measurements using frequency selection with an ideal root raised-cosine receiver filter. The video signal of the analyser or receiver is gated so that only that part of the spectrum generated by the digital modulation is measured. The measurement shall be made over at least 50 % of the symbol periods in one time slot. The passband, average power and gating may be obtained from analogue circuits or through numerical calculations.

The test shall be conducted with $\pi/4$ DQPSK modulation and if the terminal supports 8-PSK modulation the test shall be repeated with 8-PSK modulation.

The results obtained shall be compared to the limits in clause 4.2.2.1.2 in order to prove compliance.

5.4.1.1.2 Out of band power arising from switching transients

Modulate the UE transmitter on a traffic channel with pseudo-random data field bits. Filler code will be transmitted on the SACCH. DVCC shall be set to binary 1. The output of the transmitter will be on only during the time slots corresponding to the Traffic Channel.

The peak output power will be used as a reference. The analyser or receiver shall make peak power measurements using frequency selection with an ideal root raised-cosine receiver filter. Obtain the peak output power reference by adjusting the centre frequency of the measuring receiver to the transmitter centre frequency under test.

The test shall be conducted with $\pi/4$ DQPSK modulation and if the terminal supports 8-PSK modulation the test shall be repeated with 8-PSK modulation. The analyser or receiver shall make peak power measurements using frequency selection with a passband equivalent to an ideal root raised-cosine receiver filter.

The results obtained shall be compared to the limits in clause 4.2.2.2.2 in order to prove compliance.

5.4.1.2 Transmitter conducted spurious emissions

Modulate the UE transmitter on a traffic channel with pseudo-random data field bits. Filler code will be transmitted on the SACCH. DVCC shall be set to binary 1. Measurements shall be made from the lowest radio frequency generated in the equipment to the tenth harmonic of the carrier except for that region within 120 kHz of the carrier frequency. The level of the carrier frequency and the various conducted spurious frequencies shall be measured with a spectrum analyser or highly selective receiver as specified in clause 5.2.1.3.

The test shall be conducted with $\pi/4$ DQPSK modulation and if the terminal supports 8-PSK modulation the test shall be repeated with 8-PSK modulation.

The results obtained shall be compared to the limits in clause 4.2.2.3.2 in order to prove compliance.

5.4.1.3 Accuracy of maximum output power

Modulate the UE on a traffic channel with pseudo-random data field bits. Transmitter power output shall be measured with the transmitter terminated in its nominal load impedance. The mean burst power shall be measured over at least 140 consecutive symbols between symbol number 6 and symbol number 162. The devices used to determine the power output shall permit determination of this power to within the accuracy required in clause 5.3.

The results obtained shall be compared to the limits in clause 4.2.2.4 in order to prove compliance.

5.4.1.4 Impact of interference on receiver performance

For $\pi/4$ DQPSK, connect a $\pi/4$ DQPSK test signal and an RF signal generator to the receiver under test. Set the $\pi/4$ DQPSK test signal to the assigned channel and set its RF level at the receiver to the specified desired signal level. Transmitted Data Field bits shall consist of pseudo-random data.

Switch the other (undesired) input RF signal source on, and set its level to the specified blocking limit level. Modulate the undesired input RF signal source with pseudo-random $\pi/4$ DQPSK data within the operating band(s) and unmodulated elsewhere. The UE shall transpond the Data Field bits via the TDMAON command with ECHO = 0 (see section 8.2.1.3 of TIA/EIA-136-270 [5]). All tests shall be performed with the delay interval compensation operational.

The undesired input RF signal source shall be varied over a continuous frequency range from the lowest intermediate frequency or lowest oscillator frequency used in the receiver, whichever is lower, to at least 6 000 MHz, and all responses shall be noted.

The sweep rate, or frequency step size and step rate, of the generator providing the undesired signal shall be slow enough to allow sufficient time for any responses to be detectable as a change in error rate. This will require the time during which this generator dwells within a frequency range equal to the receiver bandwidth to be greater than the measurement interval used for error rate determinations. Special attention should be given to measurements around frequencies at which spurious responses are more likely to occur; e.g. due to "image" and harmonically related frequencies.

For each spurious response, measure the bandwidth over which the spurious response occurs and the minimum signal required to cause the spurious response.

For 8-PSK, connect an 8-PSK test signal and an RF signal generator to the receiver under test. Set the 8-PSK test signal to the assigned channel and set its RF level at the receiver to the specified desired signal level. Transmitted Data Field bits shall consist of pseudo-random data.

Switch the other (undesired) input RF signal source on, and set its level to the specified blocking limit level. Modulate the undesired input RF signal source with pseudo-random 8-PSK data within the operating band(s) and unmodulated elsewhere. The UE shall transpond the Data Field bits via the TDMAON command with ECHO = 0 (see section 8.2.1.3 of TIA/EIA-136-270 [5]). All tests shall be performed with the delay interval compensation optional.

The undesired input RF signal source shall be varied over a continuous frequency range from the lowest intermediate frequency or lowest oscillator frequency used in the receiver, whichever is lower, to at least 6 000 MHz, and all responses shall be noted.

The sweep rate, or frequency step size and step rate, of the generator providing the undesired signal shall be slow enough to allow sufficient time for any responses to be detectable as a change in error rate. This will require the time during which this generator dwells within a frequency range equal to the receiver bandwidth to be greater than the measurement interval used for error rate determinations. Special attention should be given to measurements around frequencies at which spurious responses are more likely to occur; e.g. due to "image" and harmonically related frequencies.

For each spurious response, measure the bandwidth over which the spurious response occurs and the minimum signal required to cause the spurious response.

The results obtained shall be compared to the limits in clause 4.2.2.5.2 in order to prove compliance.

5.4.1.5 Receiver adjacent channel selectivity

Terminate the audio output of the receiver in its normally intended load, disable the expander, and make measurements using a C-message weighted filter:

- a) Connect two RF signal generators equally coupled to the receiver antenna input terminals through a suitable matching network. Set the first RF signal generator to the assigned channel frequency and modulate it with a 1 004 Hz tone to ± 8 kHz peak frequency deviation. Switch the second generator off. Adjust the first RF signal generator level to produce a 12 dB SINAD measurement at the audio-output terminals of the receive path. Record the RF signal level and increase this first RF signal generator output by 3 dB;
- b) Set the frequency of the second RF signal generator to either 30 kHz or 60 kHz above the frequency of the first RF signal generator and modulate it with a 400 Hz tone to ± 8 kHz peak frequency deviation. Adjust the level of the second RF signal generator to reduce the SINAD measurement back to 12 dB from the first RF signal generator. Record the RF signal level;
- c) Repeat step (b) with the frequency of the second RF signal generator set to either 30 kHz or 60 kHz below the frequency of the first RF signal generator;
- d) Calculate the ratios, in dB, of the unwanted signal levels measured in steps (b) and (c) to the reference level obtained in step (a). For each case of adjacent and alternate-channel unwanted input signals, the smaller of these ratios for the above and below channel unwanted signals is the minimum selectivity.

The results obtained shall be compared to the limits in clause 4.2.2.6.2 in order to prove compliance.

5.4.1.6 Receiver conducted spurious emissions

5.4.1.6.1 Initial conditions

The UE shall be operating in Idle Mode - that is powered up but no channel shall be allocated. The receiver antenna connector shall be connected to a spectrum analyser or selective voltmeter with the same characteristic impedance.

5.4.1.6.2 Test procedure

The detecting device shall be configured to perform the measurements in the frequency ranges and corresponding measurement bandwidths defined in clause 4.2.2.7.2. The video bandwidth shall be set to approximately three times the resolution bandwidth. The power shall be measured over the frequency ranges specified in clause 4.2.2.7.2.

The results obtained shall be compared to the limits in clause 4.2.2.7.2 in order to prove compliance.

5.4.2 Essential radio test suites (200 kHz)

5.4.2.1 Spectrum emissions mask

5.4.2.1.1 Initial conditions

UE operating as follows:

- Transmitting RLC data blocks containing random data with the highest number of uplink slots;

- In frequency hopping mode, with the hopping pattern includes only three channels, B, M and T.

For guidance on a suitable procedure, see TS 151 010 [14].

5.4.2.1.2 Test procedure

This procedure shall apply to both GMSK and 8PSK modulations.

NOTE: When averaging is in use during frequency hopping mode, the averaging only includes bursts transmitted when the hopping carrier corresponds to the nominal carrier of the measurement.

- a) In steps b) to h) the FT is equal to M;
- b) The other settings of the spectrum analyser are set as follows:
 - Zero frequency scan;
 - Resolution bandwidth: 30 kHz;
 - Video bandwidth: 30 kHz;
 - Video averaging: may be used, depending on the implementation of the test.

The video signal of the spectrum analyser is "gated" such that the spectrum generated by at least 40 of the symbols 87 to 132 of the burst in one of the active time slots is the only spectrum measured. This gating may be analogue or numerical, dependent upon the design of the spectrum analyser. Only measurements during transmitted bursts on the nominal carrier of the measurement are included. The spectrum analyser averages over the gated period and over 200 or 50 such bursts, using numerical and/or video averaging.

- c) By tuning the spectrum analyser centre frequency to the measurement frequencies the power level is measured over 50 bursts at all multiples of 30 kHz offset from FT to <1 800 kHz;
- d) The resolution and video bandwidth on the spectrum analyser are adjusted to 100 kHz and the measurements are made at the following frequencies:
 - on every frequency channel from 1 800 kHz offset from the carrier to the edge of the relevant transmit band for each measurement over 50 bursts;
 - at 200 kHz intervals over the 2 MHz either side of the relevant transmit band for each measurement over 50 bursts;
 - at 200 kHz intervals over the band 450 MHz to 496 MHz for each measurement over 50 bursts;
 - at 200 kHz intervals over the band 925 MHz to 960 MHz for each measurement over 50 bursts;
 - at 200 kHz intervals over the band 1 805 MHz to 1 880 MHz for each measurement over 50 bursts;
 - at 200 kHz intervals over the band 1 930 MHz to 1 990 MHz for each measurement over 50 bursts.
- e) The UE is commanded to its minimum power control level. The spectrum analyser is set again as in b);
- f) By tuning the spectrum analyser centre frequency to the measurement frequencies the power level is measured over 200 bursts at the following frequencies:

FT;

FT + 100 kHz FT - 100 kHz;

FT + 200 kHz FT - 200 kHz;

FT + 250 kHz FT - 250 kHz;

FT + 200 kHz x N FT - 200 kHz x N

where N = 2, 3, 4, 5, 6, 7, and 8

and FT = RF channel nominal centre frequency.

- g) Steps a) to f) is repeated except that in step a) the spectrum analyser is gated so that the burst of the next active time slot is measured;
- h) The spectrum analyser settings are adjusted to:
- Zero frequency scan;
 - Resolution bandwidth: 30 kHz;
 - Video bandwidth: 100 kHz;
 - Peak hold

The spectrum analyser gating of the signal is switched off.

The UE is commanded to its maximum power control level in every transmitted time slot.

- i) By tuning the spectrum analyser centre frequency to the measurement frequencies the power level is measured at the following frequencies:
- FT + 400 kHz FT - 400 kHz;
 - FT + 600 kHz FT - 600 kHz;
 - FT + 1,2 MHz FT - 1,2 MHz;
 - FT + 1,8 MHz FT - 1,8 MHz;

where FT = RF channel nominal centre frequency.

The duration of each measurement (at each frequency) will be such as to cover at least 10 burst transmissions at FT.

- j) Step i) is repeated for power control levels 7 and 11;
- k) Steps b), f), h) and i) are repeated with FT equal to B except that in step h) the UE is commanded to power control level 11 rather than maximum power;
- l) Steps b), f), h) and i) are repeated with FT equal to T except that in step h) the UE is commanded to power control level 11 rather than maximum power;
- m) Steps a) b) f) h), and i) are repeated under extreme test conditions (annex C, TC2.2) except that at step h) the UE is commanded to power control level 11.

The results obtained shall be compared to the limits in clause 4.2.3.1.2 in order to prove compliance.

5.4.2.2 Conducted spurious emissions

5.4.2.2.1 Initial conditions

A TBF is set up on an M with UE operating as follows:

- all blocks are used for timeslot 1 for downlink;
- loopback its channel decoder output to channel encoder input;
- at maximum output power.

For guidance on a suitable procedure, see TS 151 010 [14].

The SS sends Standard Test Signal using MCS-1 channel coding.

5.4.2.2.2 Procedure

- a) Measurements are made in the frequency range 100 kHz to 12,75 GHz. Spurious emissions are measured at the antenna connector of the transceiver, as the power level of any discrete signal, higher than the requirement in table 13 minus 6 dB, delivered into a 50 Ω load.

The measurement bandwidth based on a 5 pole synchronously tuned filter is according to table 27. The power indication is the peak power detected by the measuring system.

The measurement on any frequency shall be performed for at least one TDMA frame period with the exception of the idle frame.

NOTE: This ensures that both the active times (UE transmitting) and the quiet times are measured.

- b) The test is repeated under extreme voltage test conditions (clause 4.1).

Table 27: Measurement bandwidths

Frequency range	Frequency offset	Filter bandwidth	Approx. video bandwidth
100 kHz to 50 MHz	-	10 kHz	30 kHz
50 MHz to 500 MHz	-	100 kHz	300 kHz
500 MHz to 12,75 GHz, excl. relevant TX band: 1 920 MHz to 1 980 MHz; and the RX band: 2 110 MHz to 2 170 MHz;	0 MHz to 10 MHz ≥ 10 MHz ≥ 20 MHz ≥ 30 MHz (offset from edge of relevant TX band)	100 kHz 300 kHz 1 MHz 3 MHz	300 kHz 1 MHz 3 MHz 3 MHz
relevant TX band: 1 920 MHz to 1 980 MHz;	1,8 MHz to 6,0 MHz > 6,0 MHz (offset from carrier)	30 kHz 100 kHz	100 kHz 300 kHz

NOTE 1: The filter and video bandwidths, and frequency offsets are only correct for measurements on a UE transmitting on an M.

NOTE 2: Due to practical implementation, the video bandwidth is restricted to a maximum of 3 MHz.

The results obtained shall be compared to the limits in clause 4.2.3.2.2.2 in order to prove compliance.

5.4.2.3 Accuracy of maximum output power

5.4.2.3.1 Introduction

Two methods of test are described, separately for:

- 1) equipment fitted with a permanent antenna connector and for;
- 2) equipment fitted with an integral antenna, and which cannot be connected to an external antenna except by the fitting of a temporary test connector as a test fixture.

NOTE: The behaviour of the UE in the system is determined to a high degree by the antenna, and this is the only transmitter test in the present document using the integral antenna. Further studies are ongoing on improved testing on the integral antenna, taking practical conditions of UE use into account.

5.4.2.3.2 Method of test for equipment with a permanent antenna connector

5.4.2.3.2.1 Initial conditions

A TBF is set up on an M with UE operating as follows:

- highest number of uplink slots;
- at maximum output power.

For guidance on a suitable procedure, see TS 151 010 [14].

5.4.2.3.2.2 Test procedure

- a) Measurement of normal burst transmitter output power:
 - For GMSK, average power is determined for each burst as follows:
 - The SS takes power measurement samples evenly distributed over the duration of one burst with a sampling rate of at least $2/T$, where T is the symbol duration. The samples are identified in time with respect to the modulation on the burst. The SS identifies the centre of the useful 147 transmitted symbols, i.e. the transition from symbol 13 to 14 of the midamble, as the timing reference;
 - The transmitter output power is calculated as the average of the samples over the 147 useful symbols. This is also used as the 0 dB reference for the power/time template;
 - For 8-PSK, power may be determined by applying the technique described for GMSK above and then averaging over multiple bursts to achieve sufficient accuracy. Alternatively, an estimation technique based on a single burst which can be demonstrated to yield the same result as the long-term average may be used. The long-term average or the estimate of long term average is used as the 0 dB reference for the power/time template.
- b) Measurement of normal burst power/time relationship. The array of power samples measured in a) are referenced in time to the centre of the useful transmitted symbols and in power to the 0 dB reference, both identified in a);
- c) Steps a) to b) are repeated on each timeslot within the multislot configuration with the UE commanded to operate on each of the power control levels defined, even those not supported by the UE;
- d) The SS commands the UE to the maximum power control level supported by the UE and steps a) to b) are repeated on each timeslot within the multislot configuration for B and T;
- e) The SS commands the UE to the maximum power control level in the first timeslot allocated within the multislot configuration and to the minimum power control level in the second timeslot allocated. Any further timeslots allocated are to be set to the maximum power control level. Steps a) to b) and corresponding measurements on each timeslot within the multislot configuration are repeated. This step is only applicable to UE which support more than one uplink time slot;
- f) Measurement of access burst transmitter output power:
 - The SS causes the UE to generate an Access Burst on an M. For guidance on a suitable procedure, see TS 151 010 [14].
 - The SS takes power measurement samples evenly distributed over the duration of the access burst as described in a). However, in this case the SS identifies the centre of the useful symbols of the burst by identifying the transition from the last bit of the synch sequence. The centre of the burst is then five data symbols prior to this point and is used as the timing reference.
 - The transmitter output power is calculated as the average of the samples over the 87 useful symbols of the burst. This is also used as the 0 dB reference for the power/time template.
- g) Measurement of access burst power/time relationship:
 - The array of power samples measured in f) are referenced in time to the centre of the useful transmitted symbols and in power to the 0 dB reference, both identified in f).

- h) Limit the UE transmit power on the Access Burst to power control level 10 (for guidance on a suitable procedure, see TS 151 010 [14]) and then steps f) to g) are repeated;
- i) Steps a) to h) are repeated under extreme test conditions (annex C, TC2.2) except that the repeats at step d) are only performed for power control level 10 and the minimum power control level of the UE.

5.4.2.3.3 Method of test for equipment with an integral antenna

NOTE: If the UE is equipped with a permanent connector, such that the antenna can be disconnected and the SS be connected directly, then the method of clause 5.4.2.3.2 will be applied.

The tests in this clause are performed on an unmodified test sample.

5.4.2.3.3.1 Initial conditions

The UE is placed in the anechoic-shielded chamber or on the outdoor test site, on an isolated support, in the position for normal use, at a distance of at least 3 metres from a test antenna, connected to the SS.

NOTE: The test method described has been written for measurement in an anechoic-shielded chamber. If an outdoor test site is used then, in addition, it is necessary to raise/lower the test antenna through the specified height range to maximize the received power levels from both the test sample and the substitution antenna.

The initial conditions for the UE are defined in clause 5.4.2.3.2.

5.4.2.3.3.2 Test procedure

- a) With the initial conditions set according to clause 5.4.2.3.3.1 the test procedure in clause 5.4.2.3.2.2 is followed up to and including step h), except that in step a), when measurements are done at maximum power for B M and T, the measurement is made eight times with the UE rotated by $n \times 45$ degrees for all values of n in the range 0 to 7.

The measurements taken are received transmitter output power measurements rather than transmitter output power measurements, the output power measurement values can be derived as follows.

- b) Assessment of test site loss for scaling of received output power measurements.

The UE is replaced by a half-wave dipole, resonating at the centre frequency of the transmit band, connected to an RF generator.

The frequency of the RF signal generator is set to the frequency of the frequency channel used for the 24 measurements in step a), the output power is adjusted to reproduce the received transmitter output power averages recorded in step a).

For each indication the power, delivered by the generator (in Watts) to the half-wave dipole, is recorded. These values are recorded in the form P_{nc} , where n = UE rotation and c = channel number.

For each channel number used compute:

$$P_{ac}(\text{Watts into dipole}) = \frac{1}{8} * \sum_{n=0}^{n=7} P_{nc}$$

from which: $P_{ac}(\text{Tx dBm}) = 10\log_{10}(P_{ac}) + 30 + 2,15$.

The difference, for each of the three channels, between the actual transmitter output power averaged over the 8 measurement orientations and the received transmitter output power at orientation $n = 0$ is used to scale the received measurement results to actual transmitter output powers for all measured power control levels and frequency channel, which can then be checked against the requirements.

- c) Temporary antenna connector calibration factors (transmit).

A modified test sample equipped with a temporary antenna connector is placed in a climatic test chamber and is linked to the SS by means of the temporary antenna connector.

Under normal test conditions, the power measurement and calculation parts of steps a) to j) of clause 5.4.2.3.2.2 are repeated except that the repeats at step d) are only performed for power control level 10 and the minimum power control level of the UE.

NOTE: The values noted here are related to the output transmitter carrier power levels under normal test conditions, which are known after step b). Therefore frequency dependent calibration factors that account for the effects of the temporary antenna connector can be determined.

d) Measurements at extreme test conditions.

NOTE: Basically the procedure for extreme conditions is:

- the power/time template is tested in the "normal" way,
- the radiated power is measured by measuring the difference with respect to the radiated power under normal test conditions.

Under extreme test conditions steps a) to h) of clause 5.4.2.3.2.2 are repeated except that the repeats at step d) are only performed for power control level 10 and the minimum power control level of the UE.

The transmitter output power under extreme test conditions is calculated for each burst type, power control level and for every frequency used by adding the frequency dependent calibration factor, determined in c), to the values obtained at extreme conditions in this step.

The results obtained shall be compared to the limits in clause 4.2.3.3.2 in order to prove compliance.

5.4.2.4 Impact of interference on receiver performance

5.4.2.4.1 Blocking and spurious response

5.4.2.4.1.1 Initial conditions

For both GMSK and 8-PSK modulations, a downlink TBF is set up on an arbitrary frequency channel in the range supported by the UE. The power control level is set to a maximum power of 0 dBm. For guidance on a suitable procedure, see TS 151 010 [14].

The SS transmits packet RLC data blocks containing random data.

In addition to the wanted Test Signal, the SS transmit a static unmodulated continuous interfering signal (Standard Test Signal I0).

5.4.2.4.1.2 Test procedure for GMSK modulation

- a) The SS is set to produce a TU_{high} GMSK wanted signal and a static interfering signal at the same time. The SS sets the amplitude of the wanted signal to 4 dB above the reference sensitivity level specified in table B.10 for PDTCH channel and in table B.12 for USF channel.
- b) The SS transmits packets on PDTCH using MSC-4 coding to UE on all allocated timeslots.
- c) The unwanted signal is of frequency FB. It is applied in turn on the subset of frequencies calculated at step d) in the overall range 100 kHz to 12,75 GHz, where FB is an integer multiple of 200 kHz.

However, frequencies in the range $FR \pm 600$ kHz are excluded.

NOTE: Allowance must be made for possible spurious signals arising from the SS. These are particularly likely at sub harmonic frequencies nFB where $n = 2, 3, 4, 5$, etc.

d) The frequencies at which the test is performed (adjusted to an integer multiple of 200 kHz channels most closely approximating the absolute frequency of the calculated blocking signal frequency) are the combined frequencies from i), ii) and iii) which follow:

i) The total frequency range formed by:

the frequencies between $F_{i0} + (IF_1 + IF_2 + \dots + IF_n + 37,5 \text{ MHz})$; and

$F_{10} - (IF_1 + IF_2 + \dots + IF_n + 37,5 \text{ MHz})$; and

the frequencies +100 MHz and -100 MHz from the edge of the relevant receive band.

Measurements are made at 200 kHz intervals.

ii) The three frequencies IF_1 , $IF_1 + 200 \text{ kHz}$, $IF_1 - 200 \text{ kHz}$.

iii) The frequencies:

$mF_{10} + IF_1$;

$mF_{10} - IF_1$;

mFR ;

where m is all positive integers greater than or equal to 2 such that either sum lies in the range 100 kHz to 12,75 GHz.

The frequencies in step ii) and iii) lying in the range of frequencies defined by step i) above need not be repeated.

Where:

F_{10} local oscillator applied to first receiver mixer;

$IF_1 \dots IF_n$ are the n intermediate frequencies;

F_{10} , IF_1 , $IF_2 \dots IF_n$ shall be declared by the manufacturer.

e) The level of the unwanted signal is set according to table 28.

Table 28: Level of unwanted signals

FREQUENCY	LEVEL IN $\text{dB}\mu\text{Vemf}$
$FR \pm 600 \text{ kHz}$ to $FR \pm 800 \text{ kHz}$	70
$FR \pm 800 \text{ kHz}$ to $FR \pm 1,6 \text{ MHz}$	70
$FR \pm 1,6 \text{ MHz}$ to $FR \pm 3 \text{ MHz}$	80
2 110 MHz to $FR - 3 \text{ MHz}$	87
$FR + 3 \text{ MHz}$ to 2 170 MHz	87
100 kHz to <1 930 MHz	113
1 930 MHz to <2 110 MHz	101
>2 110 MHz to 2 230 MHz	101
>2 230 MHz to 12 750 MHz	113

f) The SS counts the number of blocks transmitted with current coding scheme and the number of these blocks not acknowledged. For guidance on a suitable procedure, see TS 151 010 [14];

g) Once the number of blocks transmitted with the current coding scheme as counted in step f) reaches or exceeds the minimum number of blocks as given in table B.9, the SS calculates the Block error ratio. The SS resets both counters.

If a failure is indicated, it is noted and counted towards the allowed exemption total. In the case of failures discovered at the predicted frequencies at steps d i), ii) or iii) the test is repeated on the adjacent channels $\pm 200 \text{ kHz}$ away. If either of these two frequencies fail then the next channel 200 kHz beyond is also be tested. This process is repeated until all channels constituting the group of failures is known;

h) The SS sets the value of the USF/MCS-4 such as to allocate the uplink to the UE;

i) The unwanted signal is of frequency FB . It is applied in turn on the subset of frequencies calculated at step d) in the overall range 100 kHz to 12,75 GHz, where FB is an integer multiple of 200 kHz.

However, frequencies in the range $FR \pm 600 \text{ kHz}$ are excluded.

NOTE: Allowance must be made for possible spurious signals arising from the SS. These are particularly likely at sub harmonic frequencies nFB where $n = 2, 3, 4, 5$, etc.

- j) The level of the unwanted signal is set according to table 28;
- k) The SS counts the number of times the USF is allocated to the UE, and the number of times the UE does not transmit while being allocated the uplink;
- l) Once the number of USF/MCS-4 allocating the uplink for the UE as counted in step k) reaches or exceeds the minimum number of blocks as given in table B.9, the SS calculates the Block error ratio. The SS resets both counters. If a failure is indicated, it is noted and counted towards the allowed exemption total.

In the case of failures discovered at the predicted frequencies at steps d i), ii) or iii) the test is repeated on the adjacent channels ± 200 kHz away. If either of these two frequencies fail then the next channel 200 kHz beyond is also be tested. This process is repeated until all channels constituting the group of failures is known.

5.4.2.4.1.3 Test procedures for 8-PSK modulation:

- a) The SS is set to produce a static 8-PSK wanted signal and a static interfering signal at the same time. The SS sets the amplitude of the wanted signal to 4 dB above the reference sensitivity level specified in table B.11 for PDTCH channel and in table 22 for USF channel;
- b) The SS transmits packets on PDTCH using MSC-9 coding to UE on all allocated timeslots;
- c) The unwanted signal is of frequency FB. It is applied in turn on the subset of frequencies calculated at step d) in the overall range 100 kHz to 12,75 GHz, where FB is an integer multiple of 200 kHz.

However, frequencies in the range $FR \pm 600$ kHz are excluded.

NOTE: Allowance must be made for possible spurious signals arising from the SS. These are particularly likely at sub harmonic frequencies nFB where $n = 2, 3, 4, 5$, etc.

- d) The frequencies at which the test is performed (adjusted to an integer multiple of 200 kHz channels most closely approximating the absolute frequency of the calculated blocking signal frequency) are the combined frequencies from i), ii) and iii) which follow:

- i) The total frequency range formed by:

the frequencies between $F_{lo} + (IF_1 + IF_2 + \dots + IF_n + 37,5 \text{ MHz})$; and

$F_{lo} - (IF_1 + IF_2 + \dots + IF_n + 37,5 \text{ MHz})$; and

the frequencies $+100 \text{ MHz}$ and -100 MHz from the edge of the relevant receive band.

Measurement are made at 200 kHz intervals;

- ii) The three frequencies IF_1 , $IF_1 + 200 \text{ kHz}$, $IF_1 - 200 \text{ kHz}$;

- iii) The frequencies:

$mF_{lo} + IF_1$,

$mF_{lo} - IF_1$,

mFR ,

where m is all positive integers greater than or equal to 2 such that either sum lies in the range 100 kHz to 12,75 GHz.

The frequencies in step ii) and iii) lying in the range of frequencies defined by step i) above need not be repeated.

Where:

F_{lo} - local oscillator applied to first receiver mixer;

$IF_1 \dots IF_n$ - are the n intermediate frequencies;

F_{10} , IF_1 , IF_2 ... IF_n shall be declared by the manufacturer.

- e) The level of the unwanted signal is set according to table 28;
- f) The SS counts the number of blocks transmitted with current coding scheme and the number of these blocks not acknowledged based on the content of the Ack/Nack Description information element in the Packet Downlink Ack/Nack as sent from the UE to the SS on the PACCH.

NOTE: Due to the error rates related to the USF, the UE is likely to occasionally miss its USF for transmitting the Packet Downlink Ack/Nack. As this requirement is not verified in this part of the test, the SS then again assigns uplink resources so the UE can send this message.

- g) Once the number of blocks transmitted with the current coding scheme as counted in step f) reaches or exceeds the minimum number of blocks as given in table B.9, the SS calculates the Block error ratio. The SS resets both counters. If a failure is indicated, it is noted and counted towards the allowed exemption total.

In the case of failures discovered at the predicted frequencies at steps d i), ii) or iii) the test is repeated on the adjacent channels ± 200 kHz away. If either of these two frequencies fail then the next channel 200 kHz beyond is also be tested. This process is repeated until all channels constituting the group of failures is known;

- h) The SS sets the value of the USF/MCS-9 such as to allocate the uplink to the UE;
- j) The unwanted signal is of frequency FB . It is applied in turn on the subset of frequencies calculated at step d) in the overall range 100 kHz to 12,75 GHz, where FB is an integer multiple of 200 kHz.

However, frequencies in the range $FR \pm 600$ kHz are excluded.

NOTE: Allowance must be made for possible spurious signals arising from the SS. These are particularly likely at sub harmonic frequencies nFB where $n = 2, 3, 4, 5$, etc.

- k) The level of the unwanted signal is set according to table 28;
- l) The SS counts the number of times the USF is allocated to the UE, and the number of times the UE does not transmit while being allocated the uplink;
- m) Once the number of USF/MCS-9 allocating the uplink for the UE as counted in step l) reaches or exceeds the minimum number of blocks as given in table B.9, the SS calculates the Block error ratio. The SS resets both counters. If a failure is indicated, it is noted and counted towards the allowed exemption total.

In the case of failures discovered at the predicted frequencies at steps d i), ii) or iii) the test is repeated on the adjacent channels ± 200 kHz away. If either of these two frequencies fail then the next channel 200 kHz beyond is also be tested. This process is repeated until all channels constituting the group of failures is known.

The results obtained shall be compared to the limits in clause 4.2.3.5.2.2 in order to prove compliance.

5.4.2.4.2 Intermodulation rejection

NOTE: The measurements address the third order intermodulation, which represents the most serious case.

5.4.2.4.2.1 Initial conditions

For both GMSK and 8-PSK modulations, a downlink TBF is set up on an arbitrary frequency channel in the range supported by the UE. The power control level is set to maximum. For guidance on a suitable procedure, see TS 151 010 [14].

The SS transmits packet RLC data blocks containing random data. The amplitude of the wanted signal is set to 4 dB above the reference sensitivity level with appropriate correction value as specified in table B.10 for GMSK modulation and table B.11 for 8-PSK modulation for PDTCH channel and in table B.12 for GMSK modulation and table B.13 for 8-PSK modulation for USF channel.

In addition to the static wanted test signal, the SS transmits two static interfering (unwanted) signals at the same time. There is no correlation in the modulation between the signals.

5.4.2.4.2.2 Test procedure for GMSK modulation:

- a) The SS transmits packets on PDTCH using MCS-4 coding to the UE on all allocated timeslots;
- b) The first interfering signal is on a frequency equal to the centre frequency of a frequency channel four above the frequency channel of the wanted signal. This signal is static, continuous and unmodulated;
- c) The second interfering signal is on a frequency channel eight above the frequency channel of the wanted signal. This signal is static, continuous and GMSK modulated by random data (I1).

The amplitude of both the interfering signals is set according to table 29;

- d) The SS counts the number of blocks transmitted with current coding scheme and the number of these blocks not acknowledged;
- e) Once the number of blocks transmitted with the current coding scheme as counted in step d) reaches or exceeds the minimum number of blocks as given in table B.9, the SS calculates the Block error ratio. The SS resets both counters;
- f) The SS repeats steps d) and e) with the two unwanted signals having frequencies corresponding to frequency channel four and eight below the frequency channel of the wanted signal;
- g) The SS repeats steps a) to f) with the receiver operating on a B;
- h) The SS repeats steps a) to f) with the receiver operating on a T;
- i) The SS repeats steps a) to f) for each of the coding schemes MCS-1 to 3;
- j) Steps a) to h) are repeated under extreme test conditions for MCS-4 only;
- k) The SS establishes the normal test conditions. An uplink TBF shall be established;
- l) The SS sets the value of the USF/MCS-4 such as to allocate the uplink to the UE.
- m) The first interfering signal is on a frequency equal to the centre frequency of a frequency channel four above the frequency channel of the wanted signal. This signal is static, continuous and unmodulated;
- n) The second interfering signal is on a frequency channel eight above the frequency channel of the wanted signal. This signal is static, continuous and GMSK modulated by random data (I1).

The amplitude of both the interfering signals is set according to table 29;

- o) The SS counts the number of times the USF is allocated to the UE, and the number of times the UE does not transmit while being allocated the uplink;
- p) Once the number of USF/MCS-4 allocating the uplink for the UE as counted in step o) reaches or exceeds the minimum number of blocks as given in table B.9, the SS calculates the Block error ratio. The SS resets both counters;
- q) The SS repeats steps o) and p) with the two unwanted signals having frequencies corresponding to frequency channel four and eight below the frequency channel of the wanted signal;
- r) The SS repeats steps l) to q) with the receiver operating on a B;
- s) The SS repeats steps l) to q) with the receiver operating on a T;
- t) The SS repeats steps l) to q) for each of the coding schemes MCS-1 to 3 with the receiver operating on an M;
- u) The SS repeats steps l) to s) under extreme test conditions for MCS-4 only.

5.4.2.4.2.3 Test procedures for 8-PSK Modulation:

- a) The SS transmits packets on PDTCH using MCS-9 coding to the UE on all allocated timeslots;
- b) The first interfering signal is on a frequency equal to the centre frequency of a frequency channel four above the frequency channel of the wanted signal. This signal is static, continuous and unmodulated;

- c) The second interfering signal is on a frequency channel eight above the frequency channel of the wanted signal. This signal is static, continuous and GMSK modulated by random data (I1).

The amplitude of both the interfering signals is set according to table 29;

- d) The SS counts the number of blocks transmitted with current coding scheme and the number of these blocks not acknowledged. For guidance on a suitable procedure, see TS 151 010 [14];
- e) Once the number of blocks transmitted with the current coding scheme as counted in step d) reaches or exceeds the minimum number of blocks as given in table B.9, the SS calculates the Block error ratio. The SS resets both counters;
- f) The SS repeats steps d) and e) with the two unwanted signals having frequencies corresponding to frequency channel four and eight below the frequency channel of the wanted signal;
- g) The SS repeats steps a) to f) with the receiver operating on a B;
- h) The SS repeats steps a) to f) with the receiver operating on a T;
- i) The SS repeats steps a) to f) for each of the coding schemes MCS-5, 6, 7 and 8 with the receiver operating on an M;
- j) The SS repeats steps a) to h) under extreme test conditions for MCS-9 only;
- k) The SS establishes the normal test conditions. An uplink TBF shall be established;
- l) The SS sets the value of the USF/MCS-9 such as to allocate the uplink to the UE;
- m) The first interfering signal is on a frequency equal to the centre frequency of a frequency channel four above the frequency channel of the wanted signal. This signal is static, continuous and unmodulated;
- n) The second interfering signal is on a frequency channel eight above the frequency channel of the wanted signal. This signal is static, continuous and GMSK modulated by random data (I1).

The amplitude of both the interfering signals is set according to table 29;

- o) The SS counts the number of times the USF is allocated to the UE, and the number of times the UE does not transmit while being allocated the uplink;
- p) Once the number of USF/MCS-9 allocating the uplink for the UE as counted in step o) reaches or exceeds the minimum number of blocks as given in table B.9, the SS calculates the Block error ratio. The SS resets both counters;
- q) The SS repeats steps o) and p) with the two unwanted signals having frequencies corresponding to frequency channel four and eight below the frequency channel of the wanted signal;
- r) The SS repeats steps l) to q) with the receiver operating on a B;
- s) The SS repeats steps l) to q) with the receiver operating on a T;
- t) The SS repeats steps l) to q) for each of the coding schemes MCS-5, 6, 7 and 8 with the receiver operating on an M;
- u) The SS repeats steps l) to s) under extreme test conditions for MCS-9 only.

Table 29: Intermodulation interfering test signal levels

first interferer	64 dB μ V _{emf}
second interferer	63 dB μ V _{emf}

The results obtained shall be compared to the limits in clause 4.2.3.5.3.2 in order to prove compliance.

5.4.2.5 Receiver co-channel rejection

5.4.2.5.1 Initial conditions

For both GMSK and 8-PSK modulations, a downlink TBF is set up on an M. The power control level is set to a maximum. For guidance on a suitable procedure, see TS 151 010 [14].

The SS transmits packet RLC data blocks containing random data. In addition to these data blocks, the SS produces an independent, uncorrelated interfering signal (I1).

5.4.2.5.2 Test procedure

For GMSK Modulation:

- a) The SS transmits packets on PDTCH using MCS-4 coding to the UE on all allocated timeslots;
- b) The fading characteristic of the wanted signal and the interfering signal is TU low, no FH applies;
- c) The co-channel interference ratio is set to 1 dB above the ratio given in table 20. The interferer shall have the same frequency hopping sequence as the wanted signal, as well as be subject to the same fading profile;
- d) The SS counts the number of blocks transmitted with current coding scheme and the number of these blocks not acknowledged. For guidance on a suitable procedure, see TS 151 010 [14];
- e) Once the number of blocks transmitted with the current coding scheme as counted in step d) reaches or exceeds the minimum number of blocks as given in table B.9, the SS calculates the Block error ratio. The SS resets both counters;
- f) The SS repeats step c) to e) with the TUhigh/noFH fading condition;
- g) The SS repeats the steps b) to e) for the coding schemes MCS-3 with TUhigh/noFH, MCS-2 with TUhigh/FH and MCS-1 with RA/noFH;
- h) The SS establishes the normal test conditions, and sets the fading function to TUhigh/noFH. An uplink TBF shall be established;
- i) The SS sets the value of the USF/MCS-4 such as to allocate the uplink to the UE, using a co-channel interference ratio of 1 dB above the ratio given in table 20;
- j) The SS counts the number of times the USF is allocated to the UE, and the number of times the UE does not transmit while being allocated the uplink;
- k) Once the number of USF/MCS-4 allocating the uplink for the UE as counted in step j) reaches or exceeds the minimum number of blocks as given in table B.9, the SS calculates the Block error ratio. The SS resets both counters;
- l) The SS repeats steps i) to k) for each of the coding scheme MCS-1 to 3.

For 8-PSK Modulation:

- a) The SS transmits packets on PDTCH using MCS-8 coding to the UE on all allocated timeslots;
- b) The fading characteristic of the wanted signal and the interfering signal is TU low, no FH applies;
- c) The co-channel interference ratio is set to 1 dB above the ratio given in table 20. The interferer shall have the same frequency hopping sequence as the wanted signal, as well as be subject to the same fading profile;
- d) The SS counts the number of blocks transmitted with current coding scheme and the number of these blocks not acknowledged. For guidance on a suitable procedure, see TS 151 010 [14];
- e) Once the number of blocks transmitted with the current coding scheme as counted in step d) reaches or exceeds the minimum number of blocks as given in table B.9, the SS calculates the Block error ratio. The SS resets both counters;
- f) The SS repeats step c) to e) with the TUhigh/noFH fading condition;

- g) The SS repeats steps c) to e) for MCS-9 with TU low/NoFH, MCS-7 with TUhigh/noFH, MCS-6 with TUhigh/FH and MCS-5 with RA/noFH;
- h) The SS establishes the normal test conditions, and sets the fading function to TUhigh/noFH. An uplink TBF shall be established;
- i) The SS sets the value of the USF/MCS-9 such as to allocate the uplink to the UE, using a co-channel interference ratio of 1 dB above the ratio given in table 20;
- j) The SS counts the number of times the USF is allocated to the UE, and the number of times the UE does not transmit while being allocated the uplink;
- k) Once the number of USF/MCS-9 allocating the uplink for the UE as counted in step j) reaches or exceeds the minimum number of blocks as given in table B.9, the SS calculates the Block error ratio. The SS resets both counters;
- l) The SS repeats steps i) to k) using USF/MCS-5, 6, 7 and 8 coding.

5.4.2.6 Receiver adjacent channel selectivity

5.4.2.6.1 Initial conditions

For both GMSK and 8-PSK modulations, a downlink TBF is set up on an M. The power control level is set to maximum. For guidance on a suitable procedure, see TS 151 010 [14].

The SS transmits RLC data blocks containing random data. In addition to the wanted test signal, the SS transmits an independent, uncorrelated interfering signal Standard Test Signal (I1). This unwanted signal is random, continuous and GMSK-modulated, and has no fixed relationship with the bit transitions of the wanted signal.

The fading characteristic of the wanted and the interfering signal is TUhigh.

5.4.2.6.1.1 Test procedure for GMSK modulation

- a) The SS transmits packets on PDTCH using MCS-1 coding to the UE on all allocated timeslots;
- b) The SS transmits the unwanted signal at a nominal frequency 200 kHz above the nominal frequency of the wanted signal. Its amplitude is set to achieve the adjacent interference ratio as specified in the conformance requirements;
- c) The SS counts the number of blocks transmitted with current coding scheme and the number of these blocks not acknowledged;
- d) Once the number of blocks transmitted with the current coding scheme as counted in step c) reaches or exceeds the minimum number of blocks as given in table B.9, the SS calculates the Block error ratio. The SS resets both counters;
- e) The SS repeats steps c) and d) with the unwanted signal transmitted at a nominal frequency 200 kHz below the nominal frequency of the wanted signal and its amplitude is set to achieve the adjacent interference ratio as specified in the conformance requirements;
- f) The SS repeats steps c) and d) with the unwanted signal transmitted at a nominal frequency 400 kHz above the nominal frequency of the wanted signal and its amplitude is set to achieve the adjacent interference ratio as specified in the conformance requirements;
- g) The SS repeats steps c) and d) with the unwanted signal transmitted at a nominal frequency 400 kHz below the nominal frequency of the wanted signal and its amplitude is set to achieve the adjacent interference ratio as specified in the conformance requirements;
- h) The SS repeats steps b) to g) for each of the coding schemes MCS-2 to 4;
- i) The SS repeats steps a) to g) under extreme test conditions for MCS-4 coding scheme only;
- j) The SS establishes the normal test conditions. An uplink TBF shall be established;
- k) The SS sets the value of the USF/MCS-1 such as to allocate the uplink to the UE;

- l) The SS transmits the unwanted signal at a nominal frequency 200 kHz above the nominal frequency of the wanted signal. Its amplitude is set to achieve the adjacent interference ratio as specified in the conformance requirements;
- m) The SS counts the number of times the USF is allocated to the UE, and the number of times the UE does not transmit while being allocated the uplink;
- n) Once the number of USF/MCS-1 allocating the uplink for the UE as counted in step m) reaches or exceeds the minimum number of blocks as given in table B.9, the SS calculates the Block error ratio. The SS resets both counters;
- o) The SS repeats steps m) and n) with the unwanted signal transmitted at a nominal frequency 200kHz below the nominal frequency of the wanted signal and its amplitude is set at to achieve the adjacent interference ratio as specified in the conformance requirements;
- p) The SS repeats steps m) and n) with the unwanted signal transmitted at a nominal frequency 400 kHz above the nominal frequency of the wanted signal and its amplitude is set to achieve the adjacent interference ratio as specified in the conformance requirements;
- q) The SS repeats steps m) and n) with the unwanted signal transmitted at a nominal frequency 400 kHz below the nominal frequency of the wanted signal and its amplitude is set to achieve the adjacent interference ratio as specified in the conformance requirements;
- r) The SS repeats steps k) to q) for each of the coding schemes USF/MCS-2 to 4;
- s) The SS repeats steps k) to q) under extreme test conditions for coding scheme USF/MCS-4 only.

5.4.2.6.1.2 Test procedures for 8-PSK modulation:

- a) The SS transmits packets on PDTCH using MCS-5 coding to the UE on all allocated timeslots;
- b) The SS transmits the unwanted signal at a nominal frequency 200 kHz above the nominal frequency of the wanted signal. Its amplitude is set to achieve the adjacent interference ratio as specified in the conformance requirements;
- c) The SS counts the number of blocks transmitted with current coding scheme and the number of these blocks not acknowledged. For guidance on a suitable procedure, see TS 151 010 [14];
- d) Once the number of blocks transmitted with the current coding scheme as counted in step c) reaches or exceeds the minimum number of blocks as given in table B.9, the SS calculates the Block error ratio. The SS resets both counters;
- e) The SS repeats steps c) and d) with the unwanted signal transmitted at a nominal frequency 200 kHz below the nominal frequency of the wanted signal and its amplitude is set to achieve the adjacent interference ratio as specified in the conformance requirements;
- f) The SS repeats steps c) and d) with the unwanted signal transmitted at a nominal frequency 400 kHz above the nominal frequency of the wanted signal and its amplitude is set to achieve the adjacent interference ratio as specified in the conformance requirements;
- g) The SS repeats steps c) and d) with the unwanted signal transmitted at a nominal frequency 400kHz below the nominal frequency of the wanted signal and its amplitude is set to achieve the adjacent interference ratio as specified in the conformance requirements;
- h) The SS repeats steps b) to g) for each of the coding schemes MCS-6 to 8 and for the coding scheme MCS-9 with the TU low fading condition for both the wanted and the interfering signal;
- i) The SS repeats steps a) to h) under extreme test conditions for coding scheme MCS-9 only;
- j) The SS establishes the normal test conditions. An uplink TBF shall be established;
- k) The SS sets the value of the USF/MCS-5 such as to allocate the uplink to the UE;

- l) The SS transmits the unwanted signal at a nominal frequency 200 kHz above the nominal frequency of the wanted signal. Its amplitude is set to achieve the adjacent interference ratio as specified in the conformance requirements;
- m) The SS counts the number of times the USF is allocated to the UE, and the number of times the UE does not transmit while being allocated the uplink;
- n) Once the number of USF/MCS-5 allocating the uplink for the UE as counted in step m) reaches or exceeds the minimum number of blocks as given in table B.9, the SS calculates the Block error ratio. The SS resets both counters;
- o) The SS repeats steps m) and n) with the unwanted signal transmitted at a nominal frequency 200 kHz below the nominal frequency of the wanted signal and its amplitude is set to achieve the adjacent interference ratio as specified in the conformance requirements;
- p) The SS repeats steps m) and n) with the unwanted signal transmitted at a nominal frequency 400 kHz above the nominal frequency of the wanted signal and its amplitude is set to achieve the adjacent interference ratio as specified in the conformance requirements;
- q) The SS repeats steps m) and n) with the unwanted signal transmitted at a nominal frequency 400kHz below the nominal frequency of the wanted signal and its amplitude is set to achieve the adjacent interference ratio as specified in the conformance requirements;
- r) The SS repeats steps k) to q) for each of the coding schemes MCS-6 to 9;
- s) The SS repeats steps k) to r) under extreme test conditions for coding scheme MCS-9 only.

The results obtained shall be compared to the limits in clause 4.2.3.6.2 in order to prove compliance.

5.4.2.7 Receiver conducted spurious emissions

5.4.2.7.1 Initial conditions

The UE shall be operating in Idle Mode - that is powered up but no channel shall be allocated. The receiver antenna connector shall be connected to a spectrum analyser or selective voltmeter with the same characteristic impedance.

5.4.2.7.2 Test procedure

The detecting device shall be configured to perform the measurements in the frequency ranges and corresponding measurement bandwidths defined in clause 4.2.3.7.2. The video bandwidth shall be set to approximately three times the resolution bandwidth. The power shall be measured over the frequency ranges specified in clause 4.2.3.7.2.

The results obtained shall be compared to the limits in clause 4.2.3.7.2 in order to prove compliance.

Annex A (normative): The EN Requirements Table (EN-RT)

Notwithstanding the provisions of the copyright clause related to the text of the present document, ETSI grants that users of the present document may freely reproduce the EN-RT proforma in this annex so that it can be used for its intended purposes and may further publish the completed EN-RT.

The EN Requirements Table (EN-RT) serves a number of purposes, as follows:

- it provides a tabular summary of all the requirements;
- it shows the status of each EN-R, whether it is essential to implement in all circumstances (Mandatory), or whether the requirement is dependent on the supplier having chosen to support a particular optional service or functionality (Optional). In particular it enables the EN-RS associated with a particular optional service or functionality to be grouped and identified;
- when completed in respect of a particular equipment it provides a means to undertake the static assessment of conformity with the EN.

Table A.1: EN Requirements Table (EN-RT)

EN Reference		EN xxx xxx-8				Comment
No.	Reference	EN-R (note)	Status			
1	4.2.2.1	Emission mask	M			30 kHz
2	4.2.2.2	Transmitter conducted spurious emissions	M			30 kHz
3	4.2.2.4	RF power output	M			30 kHz
4	4.2.2.5	Blocking and spurious response	M			30 kHz
5	4.2.2.6	Adjacent and alternate channel desensitization	M			30 kHz
6	4.2.2.7	Receiver conducted spurious emissions	M			30 kHz
7	4.2.3.1	Emission mask	M			200 kHz
8	4.2.3.2	Transmitter conducted spurious emissions	M			200 kHz
9	4.2.3.3	RF power output	M			200 kHz
10	4.2.3.5	Impact of interference on receiver performance	M			200 kHz
11	4.2.3.6	Receiver adjacent channel selectivity	M			200 kHz
12	4.2.3.7	Receiver conducted spurious emissions	M			200 kHz

NOTE: These EN-Rs are justified under article 3.2 of the R&TTE Directive.

Key to columns:

No	Table entry number;
Reference	Clause reference number of conformance requirement within the present document;
EN-R	Title of conformance requirement within the present document;
Status	Status of the entry as follows:
M	Mandatory, shall be implemented under all circumstances;
O	Optional, may be provided, but if provided shall be implemented in accordance with the requirements;
O.n	this status is used for mutually exclusive or selectable options among a set. The integer "n" shall refer to a unique group of options within the EN-RT. A footnote to the EN-RT shall explicitly state what the requirement is for each numbered group. For example, "It is mandatory to support at least one of these options", or, "It is mandatory to support exactly one of these options".
Comments	To be completed as required.

Annex B (normative): Propagation conditions

B.1 Simple wideband propagation model

Radio propagation in the mobile radio environment is described by highly dispersive multipath caused by reflection and scattering. The paths between base station and UE may be considered to consist of large reflectors and/or scatterers some distance to the UE, giving rise to a number of waves that arrive in the vicinity of the UE with random amplitudes and delays.

Close to the UE these paths are further randomized by local reflections or diffractions. Since the UE will be moving, the angle of arrival must also be taken into account, since it affects the Doppler shift associated with a wave arriving from a particular direction. Echoes of identical delays arise from reflectors located on an ellipse.

The multipath phenomenon may be described in the following way in terms of the time delays and the Doppler shifts associated with each delay:

$$z(t) = \iint_{R^2} y(t - T) S(T, f) \exp(2i\pi f T) df dT$$

where the terms on the right-hand side represent the delayed signals, their amplitudes and Doppler spectra.

It has been shown that the criterion for wide sense stationarity is satisfied for distances of about 10 metres. Based on the wide sense stationary uncorrelated scattering (WSSUS) model, the average delay profiles and the Doppler spectra are necessary to simulate the radio channel.

In order to allow practical simulation, the different propagation models will be presented here in the following terms:

- 1) a discrete number of taps, each determined by their time delay and their average power;
- 2) the Rayleigh distributed amplitude of each tap, varying according to a Doppler spectrum $S(f)$.

B.2 Doppler spectrum types

In this clause, we define the two types of Doppler spectra which will be used for the modelling of the channel. Throughout this clause the following abbreviations will be used:

- $f_d = v/\lambda$, represents the maximum Doppler shift, with v (in ms^{-1}) representing the vehicle speed, and λ (in m) the wavelength.

The following types are defined:

- a) CLASS is the classical Doppler spectrum and will be used in all but one case:

$$\text{(CLASS)} \quad S(f) = A / (1 - (f/f_d)^2)^{0.5} \quad \text{for } f \in [-f_d, f_d];$$

- b) RICE is the sum of a classical Doppler spectrum and one direct path, such that the total multipath contribution is equal to that of the direct path. This power spectrum is used for the shortest path of the RA model:

$$\text{(RICE)} \quad S(f) = 0,41 / (2\pi f_d (1 - (f/f_d)^2)^{0.5}) + 0,91 \delta(f - 0,7 f_d) \quad \text{for } f \in]-f_d, f_d[$$

B.3 Propagation models

In this clause a number of propagation models are defined. As a general principle these models are referred to as NAME_x, where NAME is the name of the particular model, which is defined thereunder, and x is the vehicle speed (in km/h) which impacts on the definition of f_d (see clause B.2) and hence on the Doppler spectra.

Those models are usually defined by 12 tap settings; however, according to the simulators available it may not be possible to simulate the complete model. Therefore a reduced configuration of 6 taps is also defined in those cases. This reduced configuration may be used in particular for the multipath simulation on an interfering signal. Whenever possible the full configuration should be used. For each model two equivalent alternative tap settings, indicated respectively by tables B.1 and B.2 in the appropriate columns.

B.1: Typical case for rural area (RA_x): (6 tap setting)

Tap number	Relative time (μ s)		Average relative power (dB)		Doppler spectrum
	(1)	(2)	(1)	(2)	
1	0,0	0,0	0,0	0,0	RICE
2	0,1	0,2	-4,0	-2,0	CLASS
3	0,2	0,4	-8,0	-10,0	CLASS
4	0,3	0,6	-12,0	-20,0	CLASS
5	0,4	-	-16,0	-	CLASS
6	0,5	-	-20,0	-	CLASS

B.2: Typical case for hilly terrain (HT_x): (12 tap setting)

Tap number	Relative time (μ s)		Average relative power (dB)		Doppler spectrum
	(1)	(2)	(1)	(2)	
1	0,0	0,0	-10,0	-10,0	CLASS
2	0,1	0,2	-8,0	-8,0	CLASS
3	0,3	0,4	-6,0	-6,0	CLASS
4	0,5	0,6	-4,0	-4,0	CLASS
5	0,7	0,8	0,0	0,0	CLASS
6	1,0	2,0	0,0	0,0	CLASS
7	1,3	2,4	-4,0	-4,0	CLASS
8	15,0	15,0	-8,0	-8,0	CLASS
9	15,2	15,2	-9,0	-9,0	CLASS
10	15,7	15,8	-10,0	-10,0	CLASS
11	17,2	17,2	-12,0	-12,0	CLASS
12	20,0	20,0	-14,0	-14,0	CLASS

The reduced setting (6 taps) is defined in table B.3.

Table B.3: Reduced HT_x, (6 tap settings)

Tap number	Relative time (μ s)		Average relative power (dB)		Doppler spectrum
	(1)	(2)	(1)	(2)	
1	0,0	0,0	0,0	0,0	CLASS
2	0,1	0,2	-1,5	-2,0	CLASS
3	0,3	0,4	-4,5	-4,0	CLASS
4	0,5	0,6	-7,5	-7,0	CLASS
5	15,0	15,0	-8,0	-6,0	CLASS
6	17,2	17,2	-17,7	-12,0	CLASS

B.4: Typical case for urban area (TUx), (12 tap setting)

Tap number	Relative time (μs)		Average relative power (dB)		Doppler spectrum
	(1)	(2)	(1)	(2)	
1	0,0	0,0	-4,0	-4,0	CLASS
2	0,1	0,2	-3,0	-3,0	CLASS
3	0,3	0,4	0,0	0,0	CLASS
4	0,5	0,6	-2,6	-2,0	CLASS
5	0,8	0,8	-3,0	-3,0	CLASS
6	1,1	1,2	-5,0	-5,0	CLASS
7	1,3	1,4	-7,0	-7,0	CLASS
8	1,7	1,8	-5,0	-5,0	CLASS
9	2,3	2,4	-6,5	-6,0	CLASS
10	3,1	3,0	-8,6	-9,0	CLASS
11	3,2	3,2	-11,0	-11,0	CLASS
12	5,0	5,0	-10,0	-10,0	CLASS

The reduced TUx setting (6 taps) is defined in table B.5.

Table B.5: Reduced TUx, (6 tap settings)

Tap number	Relative time (μs)		Average relative power (dB)		Doppler spectrum
	(1)	(2)	(1)	(2)	
1	0,0	0,0	-3,0	-3,0	CLASS
2	0,2	0,2	0,0	0,0	CLASS
3	0,5	0,6	-2,0	-2,0	CLASS
4	1,6	1,6	-6,0	-6,0	CLASS
5	2,3	2,4	-8,0	-8,0	CLASS
6	5,0	5,0	-10,0	-10,0	CLASS

Table B.6: Profile for equalization test (EQx), (6 tap setting)

Tap number	Relative time (μs)	Average relative power (dB)	Doppler spectrum
1	0,0	0,0	CLASS
2	3,2	0,0	CLASS
3	6,4	0,0	CLASS
4	9,6	0,0	CLASS
5	12,8	0,0	CLASS
6	16,0	0,0	CLASS

Table B.7: Typical case for very small cells (Tlx), (2 tap setting)

Tap number	Relative time (μs)	Average relative power (dB)	Doppler spectrum
1	0.0	0.0	CLASS
2	0.4	0.0	CLASS

B.4 Receiver reference sensitivity

Statistical testing of receiver BLER performance

Error Definition

Block Error Ratio (BLER):

The Block Error Ratio is the ratio of blocks received in error to the total number of received blocks, where a block is defined as received in error if the error detection functions in the receiver indicate an error as the result of the Block Check Sequence (BCS).

For USF the Block Error Ratio is the ratio of incorrectly interpreted USF to the total number of received USF.

Test criteria

For packet switched mode, the interference level at which a fixed Block Error Ratio is met is tested with a 1 dB offset in the receive level and the interference level.

If the error events can be assumed to be random independent variables, outputs of stationary random processes with identical Gaussian distributions, the previous figures suggest a number of events not lower than 200 in AWGN channel and not lower than 600 in a multipath environment.

For multipath propagation conditions the hypothesis of stationary random processes does not generally hold. In case of non-frequency hopping operation mode, the radio channel may be assumed to change 10 times per wavelength of travelled distance and to be short term stationary in between. So, in this case, the required observation time for having good statistical properties should not be lower (with some rounding) than that reported in table B.8.

Table B.8: Minimum test time according to propagation profile

Propagation conditions	TUlow	TU high	HT	RA
Min. test time (s)	500	15	7,5	6

Table B.9 details, for the different test conditions, the minimum number of blocks required in order to meet points 1) to 3); the corresponding test time (point 4) can be consequently computed.

Table B.9: Test conditions

Type of test	Type of channel	Propagation/ frequency conditions	Specified BLER %	Minimum No of RLC blocks
Sensitivity	PDTCH/MCS-1 to 4	static	10	2 000
"	PDTCH/MCS-1 to 4	TU high/no FH	10	2 000
"	PDTCH/MCS-1 to 4	TU high/FH	10	2 000
"	PDTCH/MCS-1 to 4	RA/no FH	10	2 000
"	PDTCH/MCS-1 to 4	HT/no FH	10	2 000
"	PDTCH/MCS-5 to 9	static	10	2 000
"	PDTCH/MCS-5 to 9	TU high/no FH	10 or 30	6 000 or 2 000
"	PDTCH/MCS-5 to 9	TU high/FH	10 or 30	6 000 or 2 000
"	PDTCH/MCS-5 to 9	RA/no FH	10 or 30	6 000 or 2 000
"	PDTCH/MCS-5 to 9	HT/no FH	10 or 30	6 000 or 2 000
"	USF/MCS-1to 4	static	1	20 000
"	USF/MCS-1to 4	TU high/no FH	1	60 000
"	USF/MCS-1to 4	TU high/FH	1	60 000
"	USF/MCS-1to 4	RA/no FH	1	60 000
"	USF/MCS-1to 4	HT/no FH	1	60 000
"	USF/MCS-5 to 9	static	1	20 000
"	USF/MCS-5 to 9	TU high/no FH	1	60 000
"	USF/MCS-5 to 9	TU high/FH	1	60 000
"	USF/MCS-5 to 9	RA/no FH	1	60 000
"	USF/MCS-5 to 9	HT/no FH	1	60 000

Type of test	Type of channel	Propagation/ frequency conditions	Specified BLER %	Minimum No of RLC blocks
Co-channel	PDTCH/MCS-1 to 4	TU low/no FH	10	6 000, but minimum of 500s
"	PDTCH/MCS-1 to 4	TUhigh/no FH	10	6 000
"	PDTCH/MCS-1 to 4	TUhigh/FH	10	6 000
"	PDTCH/MCS-1 to 4	RA/no FH	10	6 000
"	PDTCH/MCS-5 to 9	TU low/no FH	10 or 30	6 000 or 2 000, but minimum of 500s
"	PDTCH/MCS-5 to 9	TUhigh/no FH	10 or 30	6 000 or 2 000
"	PDTCH/MCS-5 to 9	TUhigh/FH	10 or 30	6 000 or 2 000
"	PDTCH/MCS-5 to 9	RA/no FH	10 or 30	6 000 or 2 000
"	USF/MCS-1 to 4	TU low/no FH	1	60 000
"	USF/MCS-1 to 4	TUhigh/no FH	1	60 000
"	USF/MCS-1 to 4	TUhigh/FH	1	60 000
"	USF/MCS-1 to 4	RA/no FH	1	60 000
"	USF/MCS-5 to 9	TU low/no FH	1	60 000
"	USF/MCS-5 to 9	TUhigh/no FH	1	60 000
"	USF/MCS-5 to 9	TUhigh/FH	1	60 000
"	USF/MCS-5 to 9	RA/no FH	1	60 000
Adjacent Channel 200kHz	PDTCH/MCS-1 to 4	TU low/No FH	10	6 000
"	PDTCH/MCS-1 to 4	TUhigh/No FH	10	6 000
"	PDTCH/MSC-5 to 9	TU low/No FH	10 or 30	6 000 or 2 000
"	PDTCH/MSC-5 to 9	TUhigh/No FH	10 or 30	6 000 or 2 000
"	USF/MCS-1 to 4	TU low/No FH	1	60 000
"	USF/MCS-1 to 4	TUhigh/No FH	1	60 000
"	USF/MCS-5 to 9	TU low/No FH	1	60 000
"	USF/MCS-5 to 9	TUhigh/No FH	1	60 000
Adjacent Channel 400kHz	PDTCH/MCS-1 to 4	TUhigh/No FH	10	6 000
"	PDTCH/MCS-5 to 9	TUhigh/No FH	10 or 30	6 000 or 2 000
"	USF/MCS-1 to 4	TUhigh/No FH	1	60 000
"	USF/MCS-5 to 9	TUhigh/No FH	1	60 000
Intermodulation Rejection	PDTCH/MCS-1 to 4	static	10	2 000
"	PDTCH/MCS-5 to 9	static	10	2 000
"	USF/MCS-1 to 4	static	1	20 000
"	USF/MCS-5 to 9	static	1	20 000
Blocking and Spurious	PDTCH/MCS-1 to 4	TUhigh/No FH	10	6 000
"	PDTCH/MCS-5 to 9	TUhigh/No FH	10 or 30	6 000 or 2 000
"	USF/MCS-1 to 4	TUhigh/No FH	1	60 000
"	USF/MCS-5 to 9	TUhigh/No FH	1	60 000

NOTE 1: For MCS-7, 8 and 9 the BLER of 10 % or 30 % is specified in the conformance requirements. For MCS-5 to 6 a BLER of 10 % is always applied.

NOTE 2: Under fading conditions the number of RLC blocks indicated above shall be transmitted on each timeslot of the multislot configuration.

Minimum input level for reference performance

The minimum input level is the signal level at the UE receiver input at which a certain BLER is met.

Conformance Requirement

- 1) The block error rate (BLER) performance for PDTCH/MCS-1 to 4 shall not exceed 10 % at input levels according to the table B.10; and for PDTCH/MCS-5 to 9 shall not exceed 10 % or 30 % depending on Coding Schemes at input levels according to the table B.10.

Table B.10: PDTCH sensitivity input level for GMSK modulation

Type of Channel	Propagation conditions				
	static	TU high (no FH)	TU high (ideal FH)	RA (no FH)	HT (no FH)
PDTCH/MCS-1 dBm	-104	-102,5	-103	-103	-101,5
PDTCH/MCS-2 dBm	-104	-100,5	-101	-100,5	-99,5
PDTCH/MCS-3 dBm	-104	-96,5	-96,5	-92,5	-94,5
PDTCH/MCS-4 dBm	-101,5	-90,5	-90,5	(see note)	(see note)

The input levels given in table B.10 have to be corrected by the following values for the following classes of UE:

- class 1 or 2 UE +2 dB

NOTE: PDTCH/MCS-4 cannot meet the reference performance for some propagation conditions.

Table B.11: PDTCH sensitivity input level for UE for 8-PSK modulation

Type of Channel	Propagation conditions				
	static	TU high (no FH)	TU high (ideal FH)	RA (no FH)	HT (no FH)
PDTCH/MCS-5 dBm	-98	-93,5	-93,5	-93	-89,5
PDTCH/MCS-6 dBm	-96	-91	-91	-88	-83,5
PDTCH/MCS-7 dBm	-93	-81,5	-80,5	(see note 2)	(see note 2)
PDTCH/MCS-8 dBm	-90,5	-80 (see note 3)	-80 (see note 3)	(see note 2)	(see note 2)
PDTCH/MCS-9 dBm	-86	(see note 2)	(see note 2)	(see note 2)	(see note 2)

NOTE 1: Ideal FH case assumes perfect decorrelation between bursts. This case may only be tested if such a decorrelation is ensured in the test. For TU high (ideal FH), sufficient decorrelation may be achieved with 4 frequencies spaced over 5 MHz.

NOTE 2: PDTCH for MCS-x cannot meet the reference performance for some propagation conditions.

NOTE 3: Performance is specified at 30 % BLER for some cases.

The input levels given in table B.11 are applicable to Class 1 or Class 2 UE. For all other UE the input levels have to be corrected by the value of -2dB.

- The block error rate (BLER) performance for USF/MCS-1 to 9 shall not exceed 1 % at input levels according to the tables B.12 and B.13.

Table B.12: USF sensitivity input level for GMSK modulation

Type of Channel	Propagation conditions				
	static	TU high (no FH)	TU high (ideal FH)	RA (no FH)	HT (no FH)
USF/MCS-1 to 4 DBm	-104	-104	-104	-104	-102,5

The input levels given in table B.12 have to be corrected by the following values for the following classes of UE:

- class 1 or 2 UE +2 dB

Table B.13: USF Sensitivity Input Level for 8-PSK modulation

Type of Channel	Propagation conditions				
	static	TU high (no FH)	TU high (ideal FH)	RA (no FH)	HT (no FH)
USF/MCS-5 to 9 DBm	-102	-99	-99	-100	-99

The input levels given in table B.13 are applicable to Class 1 or Class 2 UE. For all other UE the input levels have to be corrected by the value of -2dB.

- 3) The reference sensitivity performance specified above need not be met in the following cases:
- For UE at the static channel, if the received level on either of the two adjacent timeslots to the wanted exceed the wanted timeslot by more than 20 dB;
 - For UE on a multislot configuration, if the received level on any of the timeslots belonging to the same multislot configuration as the wanted time slot, exceed the wanted time slot by more than 6 dB;
 - The interfering adjacent time slots shall be static with valid GSM signals in all cases.
- 4) For an UE allocated a USF on a PDCH with a random RF input or a valid PDCH signal with a random USF not equal to the allocated USF, the overall reception shall be such that the UE shall detect the allocated USF in less than 1 % of the radio blocks for GMSK modulated signals and 1 % for 8-PSK modulated signals. This requirement shall be met for all input levels up to -40 dBm for GMSK modulated signals and up to -40 dBm for 8-PSK modulated signals.

Annex C (informative): Normal and extreme test conditions (TC)

C.1 Power sources and ambient temperatures (TC2)

During testing, the power source of the equipment shall be replaced by a test power source, capable of producing normal and extreme test voltages as specified in clauses C.1.2 and C.1.3. The internal impedance of the test power source shall be low enough for its effect on the test results to be negligible. For the purpose of tests, the voltage of the power source shall be measured at the input terminals of the equipment. If the equipment is provided with a permanently connected power cable, the test voltage shall be that measured at the point of connection of the power cable to the equipment. In equipment with incorporated batteries the test power source shall be applied as close to the battery terminals as practicable.

During tests the power source voltages shall be maintained within a tolerance of ± 3 % relative to the voltage at the beginning of each test.

C.1.1 Normal test conditions (TC2.1)

The normal temperature and humidity conditions for tests shall be any convenient combination of temperature and humidity within the following ranges:

Temperature: $+15^{\circ}\text{C}$ to $+35^{\circ}\text{C}$ (degrees Celsius)

Relative humidity: 20 % to 75 %

NOTE: When it is impracticable to carry out the tests under the conditions stated above, the actual temperature and relative humidity during the tests shall be recorded in the test report.

The normal test voltage for equipment to be connected to the mains shall be the nominal mains voltage. For the purpose of these specifications, the nominal voltage shall be the declared voltage or any of the declared voltages for which the equipment was designed. The frequency of the test power source corresponding to the mains shall be within 1 Hz of the nominal mains frequency.

When the radio equipment is intended for operation from the usual types of regulated lead-acid battery power source of vehicles, the normal test voltage shall be 1,1 times the nominal voltage of the battery (6 volts, 12 volts etc.).

For operation from other power sources or types of battery (primary or secondary) the normal test voltage shall be that declared by the equipment manufacturer.

C.1.2 Extreme test conditions (TC2.2)

For tests under extreme test conditions the 4 combinations of extreme voltages and extreme temperatures in table C.1 shall be applied.

Table C.1: Extreme test conditions

	1	2	3	4
Temperature	High	High	Low	Low
Voltage	High	Low	High	Low

For tests at extreme ambient temperatures measurements shall be made at the temperatures given in table C.2.

For tests at the high temperature, after thermal balance has been achieved, the UE is switched on in the transmit condition (non DTX) for a period of one minute followed by 4 minutes in the idle mode (non DRX) after which the UE shall meet the specified requirements.

For tests at the low temperature, after thermal balance has been achieved, the UE is switched to the idle mode (non DRX) for a period of one minute after which the UE shall meet the specified requirements.

Table C.2: Extreme temperatures

	Temperature (degrees Celsius)	
	Low	High
Handheld	-10	+55
Vehicular or Portable	-20	+55

For tests at extreme voltages measurements shall be made at the lower and higher extreme voltages as declared by the UE manufacturer. For UE that can be operated from one or more of the power sources listed below, the lower extreme voltage shall not be higher, and the higher extreme voltage shall not be lower than that specified in table C.3.

Table C.3: Extreme voltages

	Voltage (relative to nominal)		
	Lower extreme	Higher extreme	Normal conditions
Power source: AC mains	0,9	1,1	1,0
Regulated lead acid battery	0,9	1,3	1,1
Non regulated batteries:			
Leclanché/ lithium	0,85	1,0	1,0
Mercury/ nickel cadmium	0,9	1,0	1,0

Annex D (informative): Source specifications for clauses 4 and 5

The test suites in Clauses 4 and 5 are derived from other specifications. This annex identifies these specifications and the clause number within them. In some cases, editorial modifications have been made to improve the clarity. These changes include:

- deletion of text relating to aspects of the source specification which are outside the scope of the present document;
- where the text contains a reference to another document, the reference is replaced by the applicable text from the document which is referenced;
- clarification that a requirement is mandatory for the purposes of the present document.

The changes are listed below.

Clause No	Source specification	Clause(s) copied	Part modified	Details of change
4.2.2.1	TIA/EIA-136-270-B	clause 3.4.1 clause 3.4.1.2.1.1		
4.2.2.2	TIA/EIA-136-270-B	clause 3.4.1.2.2		
4.2.2.3	TIA/EIA-136-270-B	clause 3.4.3.2		
4.2.2.4	TIA/EIA-136-270-B	clause 3.2.2		
4.2.2.5	TIA/EIA-136-270-B	clause 3.2.2		
4.2.2.6	TIA/EIA-136-270-B	clause 2.3.2.2		
4.2.3.1	TS 151 010-1 v4.1.0 (200-10)	clause 13.17.4		
4.2.3.2	TS 151 010-1 v4.1.0 (200-10)	clause 12.1		TR-45.3.5/01.01.23.22
4.2.3.3	TS 151 010-1 v4.1.0 (200-10)	clause 13.17.3		
4.2.3.4	TS 151 010-1 v4.1.0 (200-10)	clause 14.18		
4.2.3.5	TS 151 010-1 v4.1.0 (200-10)	clause 14.18.5		
4.2.3.6	TS 151 010-1 v4.1.0 (200-10)	clause 14.18.2		
4.2.3.7	TS 151 010-1 v4.1.0 (200-10)	clause 14.18.3		
5.4.1.1	TIA/EIA-136-270-B	clause 3.4.1 clause 3.4.1.2.1.1		
5.4.1.2	TIA/EIA-136-270-B	clause 3.4.1.2.2		
5.4.1.3	TIA/EIA-136-270-B	clause 3.4.3.2,		
5.4.1.4	TIA/EIA-136-270-B	clause 2.3.2		
5.4.1.5	TIA/EIA-136-270-B	clause 2.3.2		
5.4.1.6	TIA/EIA-136-270-B	clause 2.3.2.2		
5.4.2.1	TS 151 010-1 v4.1.0 (200-10)	clause 13.17.4		
5.4.2.2	TS 151 010-1 v4.1.0 (200-10)	clause 12.1		TR-45.3.6/00.01.23.22
5.4.2.3	TS 151 010-1 v4.1.0 (200-10)	clause 13.17.3.4		
5.4.2.4	TS 151 010-1 v4.1.0 (200-10)	clause 14.18.5.4 clause 14.18.5.5 clause 14.18.4.4		
5.4.2.5	TS 151 010-1 v4.1.0 (200-10)	clause 14.18.2		
5.4.2.6	TS 151 010-1 v4.1.0 (200-10)	clause 14.18.3		

Annex E (informative): The EN title in the official languages

Language	EN title
Danish	
Dutch	
English	Electromagnetic compatibility and Radio spectrum Matters (ERM); Base Stations (BS) and User Equipment (UE) for IMT-2000 Third-Generation cellular networks; Part 8: Harmonized standard for IMT-2000, TDMA Single-Carrier (UWC 136) (UE) covering essential requirements of article 3.2 of the R&TTE Directive
Finnish	
French	
German	
Greek	
Icelandic	
Italian	
Portuguese	
Spanish	
Swedish	

Annex F (informative): Bibliography

- ETSI EN 300 607-1: "Digital cellular telecommunications system (Phase 2+); Mobile Station (MS) conformance specification; Part 1: Conformance specification (GSM 11.10-1 version 8.1.1 Release 1999)".
- ETSI SR 001 470 (V1.1.2): "Guidance to the production of candidate Harmonized Standards for application under the R&TTE Directive (1999/5/EC); Pro-forma candidate Harmonized Standard".
- ETSI EG 201 399 (V1.1.1): "A guide to the production of Harmonized standards for application under the R&TTE Directive".
- Directive 98/34/EC of the European Parliament and of the Council of 22 June 1998 laying down a procedure for the provision of information in the field of technical standards and regulations.

History

Document history			
V1.1.1	April 2001	Public Enquiry	PE 20010824: 2001-04-25 to 2001-08-24