

# ETSI EN 301 908-7 V4.2.1 (2010-03)

---

*Harmonized European Standard (Telecommunications series)*

**Electromagnetic compatibility  
and Radio spectrum Matters (ERM);  
Base Stations (BS), Repeaters and User Equipment (UE)  
for IMT-2000 Third-Generation cellular networks;  
Part 7: Harmonized EN for IMT-2000,  
CDMA TDD (UTRA TDD and E-UTRA TDD) (BS)  
covering the essential requirements  
of article 3.2 of the R&TTE Directive**

---



---

Reference

REN/ERM-TFES-005-7

---

Keywords

3G, 3GPP, cell, digital, IMT-2000, mobile, radio, regulation, TD-CDMA, TDD, UMTS

**ETSI**

650 Route des Lucioles  
F-06921 Sophia Antipolis Cedex - FRANCE

Tel.: +33 4 92 94 42 00 Fax: +33 4 93 65 47 16

Siret N° 348 623 562 00017 - NAF 742 C  
Association à but non lucratif enregistrée à la  
Sous-Préfecture de Grasse (06) N° 7803/88

---

**Important notice**

Individual copies of the present document can be downloaded from:

<http://www.etsi.org>

The present document may be made available in more than one electronic version or in print. In any case of existing or perceived difference in contents between such versions, the reference version is the Portable Document Format (PDF). In case of dispute, the reference shall be the printing on ETSI printers of the PDF version kept on a specific network drive within ETSI Secretariat.

Users of the present document should be aware that the document may be subject to revision or change of status. Information on the current status of this and other ETSI documents is available at

<http://portal.etsi.org/tb/status/status.asp>

If you find errors in the present document, please send your comment to one of the following services:

[http://portal.etsi.org/chaicor/ETSI\\_support.asp](http://portal.etsi.org/chaicor/ETSI_support.asp)

---

**Copyright Notification**

No part may be reproduced except as authorized by written permission.  
The copyright and the foregoing restriction extend to reproduction in all media.

© European Telecommunications Standards Institute 2010.  
All rights reserved.

**DECT™**, **PLUGTESTS™**, **UMTS™**, **TIPHON™**, the TIPHON logo and the ETSI logo are Trade Marks of ETSI registered for the benefit of its Members.

**3GPP™** is a Trade Mark of ETSI registered for the benefit of its Members and of the 3GPP Organizational Partners.

**LTE™** is a Trade Mark of ETSI currently being registered

for the benefit of its Members and of the 3GPP Organizational Partners.

**GSM®** and the GSM logo are Trade Marks registered and owned by the GSM Association.

# Contents

Intellectual Property Rights .....	6
Foreword.....	6
Introduction .....	7
1 Scope .....	8
2 References .....	8
2.1 Normative references .....	9
2.2 Informative references.....	9
3 Definitions, symbols and abbreviations .....	10
3.1 Definitions .....	10
3.2 Symbols.....	10
3.3 Abbreviations .....	11
4 Technical requirements specifications .....	12
4.1 Environmental profile.....	12
4.2 Conformance requirements .....	12
4.2.1 Introduction.....	12
4.2.2 Spectrum emission mask .....	12
4.2.2.1 Definition .....	12
4.2.2.1.1 3,84 Mcps TDD option.....	12
4.2.2.1.2 1,28 Mcps TDD option.....	13
4.2.2.1.3 7,68 Mcps TDD option.....	13
4.2.2.2 Limits .....	13
4.2.2.2.1 3,84 Mcps TDD option.....	13
4.2.2.2.2 1,28 Mcps TDD option.....	14
4.2.2.2.3 7,68 Mcps TDD option.....	15
4.2.2.3 Conformance .....	16
4.2.3 Transmitter adjacent channel leakage power ratio .....	16
4.2.3.1 Definition .....	16
4.2.3.2 Limits .....	17
4.2.3.2.1 General requirements.....	17
4.2.3.2.2 Co-existence with UTRA-FDD .....	17
4.2.3.2.3 Co-existence with unsynchronized UTRA TDD on adjacent channels .....	18
4.2.3.3 Conformance .....	20
4.2.4 Transmitter spurious emissions.....	20
4.2.4.1 Definition .....	20
4.2.4.2 Limits .....	20
4.2.4.2.1 General requirements.....	20
4.2.4.2.2 Co-existence with GSM900.....	21
4.2.4.2.3 Co-existence with DCS1800 .....	22
4.2.4.2.4 Co-existence with UTRA FDD .....	22
4.2.4.2.5 Co-existence with unsynchronized TDD.....	23
4.2.4.3 Conformance .....	23
4.2.5 Base station maximum output power.....	23
4.2.5.1 Definition .....	23
4.2.5.2 Limits .....	23
4.2.5.3 Conformance.....	24
4.2.6 Transmit intermodulation .....	24
4.2.6.1 Definition .....	24
4.2.6.2 Limits .....	24
4.2.6.2.1 3,84 Mcps TDD option.....	24
4.2.6.2.2 1,28 Mcps TDD option.....	24
4.2.6.2.3 7,68 Mcps TDD option.....	24
4.2.6.3 Conformance.....	24
4.2.7 Receiver spurious emissions .....	25

4.2.7.1	Definition .....	25
4.2.7.2	Limits .....	25
4.2.7.2.1	3,84 Mcps TDD option.....	25
4.2.7.2.2	1,28 Mcps TDD option.....	25
4.2.7.2.3	7,68 Mcps TDD option.....	25
4.2.7.3	Conformance.....	26
4.2.8	Receiver blocking characteristics .....	26
4.2.8.1	Definition .....	26
4.2.8.2	Limits .....	26
4.2.8.2.1	3,84 Mcps TDD option.....	26
4.2.8.2.2	1,28 Mcps TDD option.....	27
4.2.8.2.3	7,68 Mcps TDD option.....	29
4.2.8.3	Conformance.....	30
4.2.9	Receiver intermodulation characteristics .....	30
4.2.9.1	Definition .....	30
4.2.9.2	Limits .....	30
4.2.9.2.1	3,84 Mcps TDD option.....	30
4.2.9.2.2	1,28 Mcps TDD option.....	30
4.2.9.2.3	7,68 Mcps TDD option.....	31
4.2.9.3	Conformance.....	31
4.2.10	Receiver adjacent channel selectivity .....	31
4.2.10.1	Definition .....	31
4.2.10.2	Limits .....	31
4.2.10.2.1	3,84 Mcps TDD option.....	31
4.2.10.2.2	1,28 Mcps TDD option.....	32
4.2.10.2.3	7,68 Mcps TDD option.....	32
4.2.10.3	Conformance.....	33
5	Testing for compliance with technical requirements.....	33
5.1	Environmental conditions for testing .....	33
5.2	Interpretation of the measurement results .....	33
5.3	Essential radio test suites.....	35
5.3.1	Spectrum emission mask .....	35
5.3.1.1	Method of test .....	35
5.3.1.1.1	Initial conditions .....	35
5.3.1.1.2	Procedure.....	38
5.3.1.2	Test requirements.....	38
5.3.1.2.1	3,84 Mcps TDD option.....	38
5.3.1.2.2	1,28 Mcps TDD option.....	39
5.3.1.2.3	7,68 Mcps TDD option.....	39
5.3.2	Transmitter adjacent channel leakage power ratio.....	39
5.3.2.1	Method of test .....	39
5.3.2.1.1	Initial conditions.....	39
5.3.2.1.2	Procedure.....	41
5.3.2.2	Test requirements.....	43
5.3.2.2.1	3,84 Mcps TDD option.....	43
5.3.2.2.2	1,28 Mcps TDD option.....	43
5.3.2.2.3	7,68 Mcps TDD option.....	43
5.3.3	Transmitter spurious emissions.....	43
5.3.3.1	Method of test .....	43
5.3.3.1.1	Initial conditions .....	43
5.3.3.1.2	Procedure.....	46
5.3.3.2	Test requirements.....	46
5.3.4	Base station maximum output power.....	46
5.3.4.1	Method of test .....	46
5.3.4.1.1	Initial conditions .....	46
5.3.4.1.2	Procedure.....	48
5.3.4.2	Test requirements.....	48
5.3.5	Transmit intermodulation .....	48
5.3.5.1	Method of test .....	48
5.3.5.1.1	Initial conditions .....	48
5.3.5.1.2	Procedure.....	53

5.3.5.2	Test requirements .....	54
5.3.6	Receiver spurious emissions .....	54
5.3.6.1	Method of test .....	54
5.3.6.1.1	Initial conditions .....	54
5.3.6.1.2	Procedure.....	55
5.3.6.2	Test requirements .....	57
5.3.7	Receiver blocking characteristics .....	57
5.3.7.1	Method of test .....	57
5.3.7.1.1	Initial conditions .....	57
5.3.7.1.2	Procedure.....	57
5.3.7.2	Test requirements .....	58
5.3.8	Receiver intermodulation characteristics .....	58
5.3.8.1	Method of test .....	58
5.3.8.1.1	Initial conditions .....	58
5.3.8.1.2	Procedure.....	59
5.3.8.2	Test requirements .....	60
5.3.9	Receiver adjacent channel selectivity .....	60
5.3.9.1	Method of test .....	60
5.3.9.1.1	Initial conditions .....	60
5.3.9.1.2	Procedure.....	61
5.3.9.1.3	Test requirements .....	62
<b>Annex A (normative):</b>	<b>HS Requirements and conformance Test specifications Table (HS-RTT).....</b>	<b>63</b>
<b>Annex B (normative):</b>	<b>BS configurations.....</b>	<b>65</b>
B.1	Receiver Diversity .....	65
B.2	Power Supply options.....	65
B.3	Ancillary RF amplifiers.....	65
B.4	BS using antenna arrays .....	65
B.4.1	Receiver tests.....	66
B.4.2	Transmitter tests .....	66
<b>Annex C (informative):</b>	<b>Environmental profile specification .....</b>	<b>67</b>
<b>Annex D (informative):</b>	<b>The EN title in the official languages .....</b>	<b>68</b>
<b>Annex E (informative):</b>	<b>Bibliography.....</b>	<b>69</b>
History .....		70

---

# Intellectual Property Rights

IPRs essential or potentially essential to the present document may have been declared to ETSI. The information pertaining to these essential IPRs, if any, is publicly available for **ETSI members and non-members**, and can be found in ETSI SR 000 314: *"Intellectual Property Rights (IPRs); Essential, or potentially Essential, IPRs notified to ETSI in respect of ETSI standards"*, which is available from the ETSI Secretariat. Latest updates are available on the ETSI Web server (<http://webapp.etsi.org/IPR/home.asp>).

Pursuant to the ETSI IPR Policy, no investigation, including IPR searches, has been carried out by ETSI. No guarantee can be given as to the existence of other IPRs not referenced in ETSI SR 000 314 (or the updates on the ETSI Web server) which are, or may be, or may become, essential to the present document.

---

## Foreword

This Harmonized European Standard (Telecommunications series) has been produced by ETSI Technical Committee Electromagnetic compatibility and Radio spectrum Matters (ERM).

The present document has been produced by ETSI in response to a mandate from the European Commission issued under Council Directive 98/34/EC [i.1] (as amended) laying down a procedure for the provision of information in the field of technical standards and regulations.

The present document is intended to become a Harmonized Standard, the reference of which will be published in the Official Journal of the European Communities referencing the Directive 1999/5/EC [i.2] of the European Parliament and of the Council of 9 March 1999 on radio equipment and telecommunications terminal equipment and the mutual recognition of their conformity ("the R&TTE Directive").

Technical specifications relevant to Directive 1999/5/EC [i.2] are given in annex A.

The present document is part 7 of a multi-part deliverable covering the Base Stations (BS), Repeaters and User Equipment (UE) for IMT-2000 Third-Generation cellular networks, as identified below:

- Part 1: "Harmonized EN for IMT-2000, introduction and common requirements, covering the essential requirements of article 3.2 of the R&TTE Directive";
- Part 2: "Harmonized EN for IMT-2000, CDMA Direct Spread (UTRA FDD and E-UTRA FDD) (UE) covering the essential requirements of article 3.2 of the R&TTE Directive";
- Part 3: "Harmonized EN for IMT-2000, CDMA Direct Spread (UTRA FDD and E-UTRA FDD) (BS) covering the essential requirements of article 3.2 of the R&TTE Directive";
- Part 4: "Harmonized EN for IMT-2000, CDMA Multi-Carrier (cdma2000) and Evolved CDMA Multi-Carrier Ultra Mobile Broadband (UMB) (UE) covering the essential requirements of article 3.2 of the R&TTE Directive";
- Part 5: "Harmonized EN for IMT-2000, CDMA Multi-Carrier (cdma2000) and Evolved CDMA Multi-Carrier Ultra Mobile Broadband (UMB) (BS) covering the essential requirements of article 3.2 of the R&TTE Directive";
- Part 6: "Harmonized EN for IMT-2000, CDMA TDD (UTRA TDD and E-UTRA TDD) (UE) covering the essential requirements of article 3.2 of the R&TTE Directive";
- Part 7: "Harmonized EN for IMT-2000, CDMA TDD (UTRA TDD and E-UTRA TDD) (BS) covering the essential requirements of article 3.2 of the R&TTE Directive";**
- Part 8: "Harmonized EN for IMT-2000, TDMA Single-Carrier (UWC 136) (UE) covering essential requirements of article 3.2 of the R&TTE Directive";
- Part 9: "Harmonized EN for IMT-2000, TDMA Single-Carrier (UWC 136) (BS) covering essential requirements of article 3.2 of the R&TTE Directive";

- Part 10: "Harmonized EN for IMT-2000, FDMA/TDMA (DECT) covering essential requirements of article 3.2 of the R&TTE Directive";
- Part 11: "Harmonized EN for IMT-2000, CDMA Direct Spread (UTRA FDD and E-UTRA FDD) (Repeaters) covering the essential requirements of article 3.2 of the R&TTE Directive";
- Part 12: "Harmonized EN for IMT-2000, CDMA Multi-Carrier (cdma2000) (Repeaters) covering the essential requirements of article 3.2 of the R&TTE Directive";
- Part 13: "Harmonized EN for IMT-2000, Evolved Universal Terrestrial Radio Access (E-UTRA) (UE) covering the essential requirements of article 3.2 of the R&TTE Directive";
- Part 14: "Harmonized EN for IMT-2000, Evolved Universal Terrestrial Radio Access (E-UTRA) (BS) covering the essential requirements of article 3.2 of the R&TTE Directive";
- Part 15: "Harmonized EN for IMT-2000, Evolved Universal Terrestrial Radio Access (E-UTRA) (FDD Repeaters) covering the essential requirements of article 3.2 of the R&TTE Directive";
- Part 16: "Harmonized EN for IMT-2000, Evolved CDMA Multi-Carrier Ultra Mobile Broadband (UMB) (UE) covering the essential requirements of article 3.2 of the R&TTE Directive";
- Part 17: "Harmonized EN for IMT-2000, Evolved CDMA Multi-Carrier Ultra Mobile Broadband (UMB) (BS) covering the essential requirements of article 3.2 of the R&TTE Directive".

<b>National transposition dates</b>	
Date of adoption of this EN:	19 February 2010
Date of latest announcement of this EN (doa):	31 May 2010
Date of latest publication of new National Standard or endorsement of this EN (dop/e):	30 November 2010
Date of withdrawal of any conflicting National Standard (dow):	30 November 2011

---

## Introduction

The present document is part of a set of standards developed by ETSI and is designed to fit in a modular structure to cover all radio and telecommunications terminal equipment within the scope of the R&TTE Directive [i.2]. The modular structure is shown in EG 201 399 [i.3].

# 1 Scope

The present document applies to the following radio equipment type:

- Base stations for IMT-2000 CDMA TDD (UTRA TDD and E-UTRA TDD).

This radio equipment type is capable of operating in all or any part of the frequency bands given in table 1-1.

**Table 1-1: CDMA TDD Base Station frequency bands**

UTRA TDD Band	Direction of transmission	IMT-2000 CDMA TDD service operating bands
a	Transmit and Receive	1 900 MHz to 1 920 MHz
	Transmit and Receive	2 010 MHz to 2 025 MHz
d	Transmit and Receive	2 570 MHz to 2 620 MHz

The requirements in the present document apply to both Wide Area Base Stations and Local Area Base Stations unless otherwise stated.

The UTRA TDD component of IMT-2000 CDMA TDD supports three options of the TDD mode with the chip rates of 3,84 Mchip/s, 1,28 Mchip/s and 7,68 Mchip/s. These three options are called the 3,84 Mcps TDD option, the 1,28 Mchip/s TDD option and the 7,68 Mcps TDD option respectively. The requirements are listed in different clauses only if the parameters deviate.

The present document covers requirements for:

- 3,84 Mcps TDD option Base Station for Releases 99, 4, 5, 6, 7 and 8;
- 1,28 Mcps TDD option Base Stations for Releases 4, 5, 6, 7 and 8;
- 7,68 Mcps TDD option Base Stations for Releases 7 and 8;
- E-UTRA TDD Base Stations for Release 8.

For general purpose Base Stations of Releases 99 and 4 only the requirements for Wide Area Base Stations shall apply.

The present document is intended to cover the provisions of Directive 1999/5/EC [i.2] (R&TTE Directive) article 3.2, which states that "... radio equipment shall be so constructed that it effectively uses the spectrum allocated to terrestrial/space radio communications and orbital resources so as to avoid harmful interference".

In addition to the present document, other ENs that specify technical requirements in respect of essential requirements under other parts of article 3 of the R&TTE Directive [i.2] may apply to equipment within the scope of the present document.

NOTE: A list of such ENs is included on the web site: <http://www.newapproach.org/>.

# 2 References

References are either specific (identified by date of publication and/or edition number or version number) or non-specific.

- For a specific reference, subsequent revisions do not apply.
- Non-specific reference may be made only to a complete document or a part thereof and only in the following cases:
  - if it is accepted that it will be possible to use all future changes of the referenced document for the purposes of the referring document;
  - for informative references.



Referenced documents which are not found to be publicly available in the expected location might be found at <http://docbox.etsi.org/Reference>.

NOTE: While any hyperlinks included in this clause were valid at the time of publication ETSI cannot guarantee their long term validity.

## 2.1 Normative references

The following referenced documents are indispensable for the application of the present document. For dated references, only the edition cited applies. For non-specific references, the latest edition of the referenced document (including any amendments) applies.

- [1] Void.
- [2] ETSI TS 125 105 (V8.5.0): "Universal Mobile Telecommunications System (UMTS); Base Station (BS) radio transmission and reception (TDD) (3GPP TS 25.105 version 8.5.0 Release 8)".
- [3] ETSI TS 125 142 (V8.4.0): "Universal Mobile Telecommunications System (UMTS); Base Station (BS) conformance testing (TDD) (3GPP TS 25.142 version 8.4.0 Release 8)".
- [4] ITU-R Recommendation SM.329-10 (2003): "Unwanted emissions in the spurious domain".
- [5] ETSI EN 301 908-1 (V4.1.2): "Electromagnetic compatibility and Radio spectrum Matters (ERM); Base Stations (BS), Repeaters and User Equipment (UE) for IMT-2000 Third-Generation cellular networks; Part 1: Harmonized EN for IMT-2000, introduction and common requirements, covering the essential requirements of article 3.2 of the R&TTE Directive".
- [6] ETSI EN 301 908-14 (V4.1.2): "Electromagnetic compatibility and Radio spectrum Matters (ERM); Base Stations (BS), Repeaters and User Equipment (UE) for IMT-2000 Third-Generation cellular networks; Part 14: Harmonized EN for IMT-2000, Evolved Universal Terrestrial Radio Access (E-UTRA) (BS) covering the essential requirements of article 3.2 of the R&TTE Directive".

## 2.2 Informative references

The following referenced documents are not essential to the use of the present document but they assist the user with regard to a particular subject area. For non-specific references, the latest version of the referenced document (including any amendments) applies.

- [i.1] Directive 98/34/EC of the European Parliament and of the Council of 22 June 1998 laying down a procedure for the provision of information in the field of technical standards and regulations.
- [i.2] Directive 1999/5/EC of the European Parliament and of the Council of 9 March 1999 on radio equipment and telecommunications terminal equipment and the mutual recognition of their conformity (R&TTE Directive).
- [i.3] ETSI EG 201 399: "Electromagnetic compatibility and Radio spectrum Matters (ERM); A guide to the production of candidate Harmonized Standards for application under the R&TTE Directive".
- [i.4] ETSI TR 100 028 (V1.4.1) (all parts): "Electromagnetic compatibility and Radio spectrum Matters (ERM); Uncertainties in the measurement of mobile radio equipment characteristics".

## 3 Definitions, symbols and abbreviations

### 3.1 Definitions

For the purposes of the present document, the following terms and definitions apply:

**ancillary RF amplifier:** piece of equipment, which when connected by RF coaxial cables to the BS, has the primary function to provide amplification between the transmit and/or receive antenna connector of a BS and an antenna without requiring any control signal to fulfil its amplifying function

**B:** appropriate frequency in the Bottom of the operating frequency band of the BS: "RF channel"

**Base Station class:** wide area Base Station or local area Base Station, as declared by the manufacturer

**chip rate:** rate of "chips" (modulated symbols after spreading) per second

**DPCHo:** mechanism used to simulate an individual intracell interferer in the cell with one code and a spreading factor of 16

**environmental profile:** range of environmental conditions under which equipment within the scope of the present document is required to comply with the provisions of the present document

**F<sub>uw</sub>:** frequency offset of the unwanted interfering signal from the assigned channel frequency of the wanted signal

**local area Base Station:** Base Station, characterized by requirements derived from Pico Cell scenarios with a BS to UE coupling loss equals to 45 dB

**M:** appropriate frequency in the Middle of the operating frequency band of the BS: "RF channel"

**maximum output power (P<sub>max</sub>):** mean power level per carrier of the Base Station measured at the antenna connector in a specific reference condition, where the period of measurement shall be a transmit timeslot excluding the guard period

**mean power:** when applied to a CDMA modulated signal this is the power (transmitted or received) in a bandwidth of at least  $(1 + \alpha)$  times the chip rate of the radio access mode, where the period of measurement shall be a transmit timeslot excluding the guard period unless otherwise stated

**output power:** mean power of one carrier of the Base Station, delivered to a load with resistance equal to the nominal load impedance of the transmitter

**RATed output Power (PRAT):** mean power level per carrier that the manufacturer has declared to be available at the antenna connector

**RRC filtered mean power:** mean power as measured through a root raised cosine filter with roll-off factor  $\alpha$  and a bandwidth equal to the chip rate of the radio access mode

**T:** appropriate frequency in the Top of the operating frequency band of the BS: "RF channel"

**wide area Base Stations:** Base Station, characterized by requirements derived from macrocell and microcell scenarios with BS to UE coupling losses equal to 70 dB and 53 dB

### 3.2 Symbols

For the purposes of the present document, the following symbols apply:

$\alpha$	roll-off factor, $\alpha = 0,22$
$\Omega$	electrical impedance
$\frac{DPCH_o - E_c}{I_{or}}$	ratio of the average transmits energy per PN chip for the DPCH <sub>o</sub> to the total transmit power spectral density in one time slot

F	Frequency (of the assigned channel frequency of the wanted signal)
$F_{uw}$	the frequency offset of the unwanted interfering signal from the assigned channel frequency of the wanted signal
$P_i$	power of the signal at antenna connector $i$
$P_s$	sum of the power for all antenna connectors

### 3.3 Abbreviations

For the purposes of the present document, the following abbreviations apply:

16QAM	16 - Quadrature Amplitude Modulation
3GPP	3 <sup>rd</sup> Generation Partnership Project
ACLR	Adjacent Channel Leakage power Ratio
ACS	Adjacent Channel Selectivity
BER	Bit Error Ratio
BS	Base Station
BTS	Base Transceiver Station
CDMA	Code Division Multiple Access
CW	Continuous Wave

NOTE: Unmodulated signal.

dB	deciBel
dBm	deciBel relative to 1 milliwatt
DC	Direct Current
DCS	Digital Cellular System
DL	Down Link (forward link)
DPCH	Dedicated Physical CHannel
DUT	Device Under Test
EUT	Equipment Under Test
E-UTRA	Evolved Universal Terrestrial Radio Access
FDD	Frequency Division Duplexing
GSM	Global System for Mobile
HS-PDSCH	High Speed Physical Downlink Shared CHannel
IMT-2000	International Mobile Telecommunications 2000
MS	Mobile Station
P	output Power
$P_{max}$	Maximum output power of the Base Station
PRAT	RATed output Power of the Base Station
R&TTE	Radio and Telecommunications Terminal Equipment
RF	Radio Frequency
RMS	Root-Mean Square
RRC	Root-Raised Cosine
Rx	Receiver
SCH	Synchronization CHannel
TDD	Time Division Duplexing
TRX	Transmitter-Receiver
TS	Time Slot
Tx	Transmitter
UARFCN	UTRA Absolute Radio Frequency Channel Number
UE	User Equipment
UL	Up Link (reverse link)
UMTS	Universal Mobile Telecommunications System
UTRA	Universal Terrestrial Radio Access
WCDMA	Wideband Code Division Multiple Access

## 4 Technical requirements specifications

### 4.1 Environmental profile

The technical requirements of the present document apply under the environmental profile for operation of the equipment, which shall be declared by the supplier. The equipment shall comply with all the technical requirements of the present document at all times when operating within the boundary limits of the required operational environmental profile.

For guidance on how a supplier can declare the environmental profile see annex C.

### 4.2 Conformance requirements

This clause describes the conformance requirements for UTRA TDD. E-UTRA Base Station conformance requirements are given in EN 301 908-14 [6].

#### 4.2.1 Introduction

To meet the essential requirement under article 3.2 of the R&TTE Directive [i.2] for IMT-2000 Base Stations (BS) seven essential parameters in addition to those in EN 301 908-1 [5] have been identified. Table 4.2.1-1 provides a cross reference between these seven essential parameters and the corresponding nine technical requirements for equipment within the scope of the present document.

To fulfil an essential parameter the compliance with all the corresponding technical requirements in table 4.2.1-1 must be verified.

**Table 4.2.1-1: Cross references**

Essential parameter	Corresponding technical requirements
Spectrum emissions mask	4.2.2 Spectrum emission mask
	4.2.3 Transmitter Adjacent Channel Leakage power Ratio (ACLR)
Conducted spurious emissions from the transmitter antenna connector	4.2.4 Transmitter spurious emissions
Accuracy of maximum output power	4.2.5 Base station maximum output power
Intermodulation attenuation of the transmitter	4.2.6 Transmit intermodulation
Conducted spurious emissions from the receiver antenna connector	4.2.7 Receiver spurious emissions
Impact of interference on receiver performance	4.2.8 Receiver blocking characteristics
	4.2.9 Receiver intermodulation characteristics
Receiver adjacent channel selectivity	4.2.10 Receiver Adjacent Channel Selectivity (ACS)

The technical requirements in the present document apply for Base Stations supporting UTRA TDD. Base stations supporting E-UTRA TDD shall fulfil requirements in EN 301 908-14 [6]. The technical requirements also apply to the BS configurations described in annex B.

#### 4.2.2 Spectrum emission mask

##### 4.2.2.1 Definition

Spectrum emission mask defines an out of band emission requirement for the Base Station transmitter. These out of band emissions are emissions immediately outside the channel bandwidth resulting from the modulation process and non-linearity in the transmitter but excluding spurious emissions.

##### 4.2.2.1.1 3,84 Mcps TDD option

The spectrum emission mask specifies the limit of the transmitter out of band emissions at frequency offsets from the assigned channel frequency of the wanted signal between 2,5 MHz and 12,5 MHz.

#### 4.2.2.1.2 1,28 Mcps TDD option

The spectrum emission mask specifies the limit of the transmitter out of band emissions at frequency offsets from the assigned channel frequency of the wanted signal between 0,8 MHz and 4 MHz.

#### 4.2.2.1.3 7,68 Mcps TDD option

The spectrum emission mask specifies the limit of the transmitter out of band emissions at frequency offsets from the assigned channel frequency of the wanted signal between 5 MHz and 25 MHz.

### 4.2.2.2 Limits

#### 4.2.2.2.1 3,84 Mcps TDD option

The requirement shall apply to both Wide Area BS and Local Area BS. The requirement shall be met by a Base Station transmitting on a single RF carrier configured in accordance with the manufacturer's specification. Emissions shall not exceed the maximum level specified in tables 4.2.2.2.1-1 to 4.2.2.2.1-4 in the frequency range of  $f_{\text{offset}}$  from 2 515 MHz to  $f_{\text{offset}}$  from the carrier frequency, where:

- $f_{\text{offset}}$  is the separation between the carrier frequency and the centre frequency of the measuring filter;
- $f_{\text{offset}_{\text{max}}}$  is either 12,5 MHz or the offset to the UMTS Tx band edge (DL transmission in the following bands: 1 900 MHz to 1 920 MHz, 2 010 MHz to 2 025 MHz and 2 570 MHz to 2 620 MHz), whichever is the greater.

The spectrum emissions measured according to clause 5.3.1.1.2 shall not exceed the maximum level specified in tables 4.2.2.2.1-1 to 4.2.2.2.1-4 for the appropriate BS maximum output power.

**Table 4.2.2.2.1-1: Test requirements for spectrum emission mask values, BS maximum output power  $P \geq 43$  dBm (3,84 Mcps TDD option)**

Frequency offset of measurement filter centre frequency, $f_{\text{offset}}$	Maximum level	Measurement bandwidth
$2,515 \text{ MHz} \leq f_{\text{offset}} < 2,715 \text{ MHz}$	-12,5 dBm	30 kHz
$2,715 \text{ MHz} \leq f_{\text{offset}} < 3,515 \text{ MHz}$	$-12,5 \text{ dBm} - 15 \left( \frac{f_{\text{offset}}}{\text{MHz}} - 2,715 \right) \text{ dB}$	30 kHz
$3,515 \text{ MHz} \leq f_{\text{offset}} < 4,0 \text{ MHz}$	-24,5 dBm	30 kHz
$4,0 \text{ MHz} \leq f_{\text{offset}} < 8,0 \text{ MHz}$	-11,5 dBm	1 MHz
$8,0 \text{ MHz} \leq f_{\text{offset}} < f_{\text{offset}_{\text{max}}}$	-11,5 dBm	1 MHz

**Table 4.2.2.2.1-2: Test requirements for spectrum emission mask values, BS maximum output power  $39 \text{ dBm} \leq P < 43 \text{ dBm}$  (3,84 Mcps TDD option)**

Frequency offset of measurement filter centre frequency, $f_{\text{offset}}$	Maximum level	Measurement bandwidth
$2,515 \text{ MHz} \leq f_{\text{offset}} < 2,715 \text{ MHz}$	-12,5 dBm	30 kHz
$2,715 \text{ MHz} \leq f_{\text{offset}} < 3,515 \text{ MHz}$	$-12,5 \text{ dBm} - 15 \left( \frac{f_{\text{offset}}}{\text{MHz}} - 2,715 \right) \text{ dB}$	30 kHz
$3,515 \text{ MHz} \leq f_{\text{offset}} < 4,0 \text{ MHz}$	-24,5 dBm	30 kHz
$4,0 \text{ MHz} \leq f_{\text{offset}} < 8,0 \text{ MHz}$	-11,5 dBm	1 MHz
$8,0 \text{ MHz} \leq f_{\text{offset}} < f_{\text{offset}_{\text{max}}}$	$P - 54,5 \text{ dB}$	1 MHz

**Table 4.2.2.2.1-3: Test requirements for spectrum emission mask values, BS maximum output power  $31 \text{ dBm} \leq P < 39 \text{ dBm}$  (3,84 Mcps TDD option)**

Frequency offset of measurement filter centre frequency, $f_{\text{offset}}$	Maximum level	Measurement bandwidth
$2,515 \text{ MHz} \leq f_{\text{offset}} < 2,715 \text{ MHz}$	$P - 51,5 \text{ dB}$	30 kHz
$2,715 \text{ MHz} \leq f_{\text{offset}} < 3,515 \text{ MHz}$	$P - 51,5 \text{ dB} - 15 \left( \frac{f_{\text{offset}}}{\text{MHz}} - 2,715 \right) \text{ dB}$	30 kHz
$3,515 \text{ MHz} \leq f_{\text{offset}} < 4,0 \text{ MHz}$	$P - 63,5 \text{ dB}$	30 kHz
$4,0 \text{ MHz} \leq f_{\text{offset}} < 8,0 \text{ MHz}$	$P - 50,5 \text{ dB}$	1 MHz
$8,0 \text{ MHz} \leq f_{\text{offset}} < f_{\text{offset}}_{\text{max}}$	$P - 54,5 \text{ dB}$	1 MHz

**Table 4.2.2.2.1-4: Test requirements for spectrum emission mask values, BS rated output power  $\text{PRAT} < 31 \text{ dBm}$  (3,84 Mcps TDD option)**

Frequency offset of measurement filter centre frequency, $f_{\text{offset}}$	Maximum level	Measurement bandwidth
$2,515 \text{ MHz} \leq f_{\text{offset}} < 2,715 \text{ MHz}$	$-20,5 \text{ dBm}$	30 kHz
$2,715 \text{ MHz} \leq f_{\text{offset}} < 3,515 \text{ MHz}$	$-20,5 \text{ dBm} - 15 \left( \frac{f_{\text{offset}}}{\text{MHz}} - 2,715 \right) \text{ dB}$	30 kHz
$3,515 \text{ MHz} \leq f_{\text{offset}} < 4,0 \text{ MHz}$	$-32,5 \text{ dBm}$	30 kHz
$4,0 \text{ MHz} \leq f_{\text{offset}} < 8,0 \text{ MHz}$	$-19,5 \text{ dBm}$	1 MHz
$8,0 \text{ MHz} \leq f_{\text{offset}} < f_{\text{offset}}_{\text{max}}$	$-23,5 \text{ dBm}$	1 MHz

#### 4.2.2.2.2 1,28 Mcps TDD option

The requirement shall apply to both Wide Area BS and Local Area BS. The requirement shall be met by a Base Station transmitting on a single RF carrier configured in accordance with the manufacturer's specification. Emissions shall not exceed the maximum level specified in tables 4.2.2.2.2-1 to 4.2.2.2.2-3 in the frequency range of  $f_{\text{offset}}$  from 0,815 MHz to  $f_{\text{offset}}$  from the carrier frequency, where:

- $f_{\text{offset}}$  is the separation between the carrier frequency and the centre frequency of the measuring filter;
- $f_{\text{offset}}_{\text{max}}$  is either 4,0 MHz or the offset to the UMTS Tx band edge (DL transmission in the following bands: 1 900 MHz to 1 920 MHz, 2 010 MHz to 2 025 MHz and 2 570 MHz to 2 620 MHz), whichever is the greater.

The spectrum emissions measured according to clause 5.3.1.1.2 shall not exceed the maximum level specified in tables 4.2.2.2.2-1 to 4.2.2.2.2-3 for the appropriate BS maximum output power.

**Table 4.2.2.2.2-1: Test Requirements for spectrum emission mask values, BS maximum output power  $P \geq 34 \text{ dBm}$  (1,28 Mcps TDD option)**

Frequency offset of measurement filter centre frequency, $f_{\text{offset}}$	Maximum level	Measurement bandwidth
$0,815 \text{ MHz} \leq f_{\text{offset}} < 1,015 \text{ MHz}$	$-18,5 \text{ dBm}$	30 kHz
$1,015 \text{ MHz} \leq f_{\text{offset}} < 1,815 \text{ MHz}$	$-18,5 \text{ dBm} - 10 \left( \frac{f_{\text{offset}}}{\text{MHz}} - 1,015 \right) \text{ dB}$	30 kHz
$1,815 \text{ MHz} \leq f_{\text{offset}} < 2,3 \text{ MHz}$	$-26,5 \text{ dBm}$	30 kHz
$2,3 \text{ MHz} \leq f_{\text{offset}} < f_{\text{offset}}_{\text{max}}$	$-11,5 \text{ dBm}$	1 MHz

**Table 4.2.2.2-2: Test Requirements for spectrum emission mask values, BS maximum output power  $26 \text{ dBm} \leq P < 34 \text{ dBm}$  (1,28 Mcps TDD option)**

Frequency offset of measurement filter centre frequency, $f_{\text{offset}}$	Maximum level	Measurement bandwidth
$0,815 \text{ MHz} \leq f_{\text{offset}} < 1,015 \text{ MHz}$	$P - 52,5 \text{ dB}$	30 kHz
$1,015 \text{ MHz} \leq f_{\text{offset}} < 1,815 \text{ MHz}$	$P - 52,5 \text{ dB} - 10 \left( \frac{f_{\text{offset}}}{\text{MHz}} - 1,015 \right) \text{ dB}$	30 kHz
$1,815 \text{ MHz} \leq f_{\text{offset}} < 2,3 \text{ MHz}$	$P - 60,5 \text{ dB}$	30 kHz
$2,3 \text{ MHz} \leq f_{\text{offset}} < f_{\text{offset}_{\text{max}}}$	$P - 45,5 \text{ dB}$	1 MHz

**Table 4.2.2.2-3: Test Requirements for spectrum emission mask values, BS maximum output power  $P < 26 \text{ dBm}$  (1,28 Mcps TDD option)**

Frequency offset of measurement filter centre frequency, $f_{\text{offset}}$	Maximum level	Measurement bandwidth
$0,815 \text{ MHz} \leq f_{\text{offset}} < 1,015 \text{ MHz}$	$-26,5 \text{ dBm}$	30 kHz
$1,015 \text{ MHz} \leq f_{\text{offset}} < 1,815 \text{ MHz}$	$-26,5 \text{ dBm} - 10 \left( \frac{f_{\text{offset}}}{\text{MHz}} - 1,015 \right) \text{ dB}$	30 kHz
$1,815 \text{ MHz} \leq f_{\text{offset}} < 2,3 \text{ MHz}$	$-34,5 \text{ dBm}$	30 kHz
$2,3 \text{ MHz} \leq f_{\text{offset}} < f_{\text{offset}_{\text{max}}}$	$-19,5 \text{ dBm}$	1 MHz

#### 4.2.2.2.3 7,68 Mcps TDD option

The requirement shall apply to both Wide Area BS and Local Area BS. The requirement shall be met by a Base Station transmitting on a single RF carrier configured in accordance with the manufacturer's specification. Emissions shall not exceed the maximum level specified in tables 4.2.2.2.3-1 to 4.2.2.2.3-4 in the frequency range of  $f_{\text{offset}}$  from 5,015 MHz to  $f_{\text{offset}}$  from the carrier frequency, where:

- $f_{\text{offset}}$  is the separation between the carrier frequency and the centre frequency of the measuring filter;
- $f_{\text{offset}_{\text{max}}}$  is either 25 MHz or the offset to the UMTS Tx band edge (DL transmission in the following bands: 1 900 MHz to 1 920 MHz, 2 010 MHz to 2 025 MHz and 2 570 MHz to 2 620 MHz), whichever is the greater.

The spectrum emissions measured according to clause 5.3.1.1.2 shall not exceed the maximum level specified in tables 4.2.2.2.3-1 to 4.2.2.2.3-4 for the appropriate BS maximum output power.

**Table 4.2.2.2.3-1: Test Requirements for spectrum emission mask values, BS maximum output power  $P \geq 43 \text{ dBm}$  (7,68 Mcps TDD option)**

Frequency offset of measurement filter centre frequency, $f_{\text{offset}}$	Maximum level	Measurement bandwidth
$5,015 \text{ MHz} \leq f_{\text{offset}} < 5,215 \text{ MHz}$	$-15,5 \text{ dBm}$	30 kHz
$5,215 \text{ MHz} \leq f_{\text{offset}} < 6,015 \text{ MHz}$	$-15,5 \text{ dBm} - 15 \cdot \left( \frac{f_{\text{offset}}}{\text{MHz}} - 5,215 \right) \text{ dB}$	30 kHz
$6,015 \text{ MHz} \leq f_{\text{offset}} < 6,5 \text{ MHz}$	$-27,5 \text{ dBm}$	30 kHz
$6,5 \text{ MHz} \leq f_{\text{offset}} < f_{\text{offset}_{\text{max}}}$	$-14,5 \text{ dBm}$	1 MHz
$15,5 \text{ MHz} \leq f_{\text{offset}} < f_{\text{offset}_{\text{max}}}$	$-14,5 \text{ dBm}$	1 MHz

**Table 4.2.2.3-2: Test Requirements for spectrum emission mask values, BS maximum output power  $39 \leq P < 43$  dBm (7,68 Mcps TDD option)**

Frequency offset of measurement filter centre frequency, $f_{\text{offset}}$	Maximum level	Measurement bandwidth
$5,015 \text{ MHz} \leq f_{\text{offset}} < 5,215 \text{ MHz}$	-15,5 dBm	30 kHz
$5,215 \text{ MHz} \leq f_{\text{offset}} < 6,015 \text{ MHz}$	$-15,5 \text{ dBm} - 15 \cdot \left( \frac{f_{\text{offset}}}{\text{MHz}} - 5,215 \right) \text{ dB}$	30 kHz
$6,015 \text{ MHz} \leq f_{\text{offset}} < 6,5 \text{ MHz}$	-27,5 dBm	30 kHz
$6,5 \text{ MHz} \leq f_{\text{offset}} < 15,5 \text{ MHz}$	-14,5 dBm	1 MHz
$15,5 \text{ MHz} \leq f_{\text{offset}} < f_{\text{offset}_{\text{max}}}$	$P - 57,5 \text{ dB}$	1 MHz

**Table 4.2.2.3-3: Test Requirements for spectrum emission mask values, BS maximum output power  $31 \leq P < 39$  dBm (7,68 Mcps TDD option)**

Frequency offset of measurement filter centre frequency, $f_{\text{offset}}$	Maximum level	Measurement bandwidth
$5,015 \text{ MHz} \leq f_{\text{offset}} < 5,215 \text{ MHz}$	$P - 54,5 \text{ dB}$	30 kHz
$5,215 \text{ MHz} \leq f_{\text{offset}} < 6,015 \text{ MHz}$	$P - 54,5 \text{ dB} - 15 \cdot \left( \frac{f_{\text{offset}}}{\text{MHz}} - 5,215 \right) \text{ dB}$	30 kHz
$6,015 \text{ MHz} \leq f_{\text{offset}} < 6,5 \text{ MHz}$	$P - 66,5 \text{ dB}$	30 kHz
$6,5 \text{ MHz} \leq f_{\text{offset}} < 15,5 \text{ MHz}$	$P - 53,5 \text{ dB}$	1 MHz
$15,5 \text{ MHz} \leq f_{\text{offset}} < f_{\text{offset}_{\text{max}}}$	$P - 57,5 \text{ dB}$	1 MHz

**Table 4.2.2.3-4: Test Requirements for spectrum emission mask values, BS maximum output power  $P < 31$  dBm (7,68 Mcps TDD option)**

Frequency offset of measurement filter centre frequency, $f_{\text{offset}}$	Maximum level	Measurement bandwidth
$5,015 \text{ MHz} \leq f_{\text{offset}} < 5,215 \text{ MHz}$	-23,5 dBm	30 kHz
$5,215 \text{ MHz} \leq f_{\text{offset}} < 6,015 \text{ MHz}$	$-23,5 \text{ dBm} - 15 \cdot \left( \frac{f_{\text{offset}}}{\text{MHz}} - 5,215 \right) \text{ dB}$	30 kHz
$6,015 \text{ MHz} \leq f_{\text{offset}} < 6,5 \text{ MHz}$	-35,5 dBm	30 kHz
$6,5 \text{ MHz} \leq f_{\text{offset}} < 15,5 \text{ MHz}$	-22,5 dBm	1 MHz
$15,5 \text{ MHz} \leq f_{\text{offset}} < f_{\text{offset}_{\text{max}}}$	-26,5 dBm	1 MHz

### 4.2.2.3 Conformance

Conformance tests described in clause 5.3.1 shall be carried out.

## 4.2.3 Transmitter adjacent channel leakage power ratio

### 4.2.3.1 Definition

Transmitter Adjacent Channel Leakage power Ratio (ACLR) is the ratio of the RRC filtered mean power centred on the assigned channel frequency to the RRC filtered mean power centred on an adjacent channel frequency. (ACLR is also an "out of band emission" requirement, see clause 4.2.2.) The requirements shall apply for all configurations of BS (single carrier or multi-carrier), and for all operating modes foreseen by the manufacturer's specification.

In some cases the requirement is expressed as adjacent channel leakage power, which is the RRC filtered mean power for the given bandwidth of the victim system at the defined adjacent channel offset.



## 4.2.3.2 Limits

### 4.2.3.2.1 General requirements

#### 4.2.3.2.1.1 3,84 Mcps TDD option

The requirement shall apply to both Wide Area BS and Local Area BS. The ACLR of a single carrier BS or a multi-carrier BS with contiguous carrier frequencies shall be equal to or greater than the limits given in table 4.2.3.2.1.1-1.

**Table 4.2.3.2.1.1-1: BS ACLR limits (3,84 Mcps TDD option)**

BS adjacent channel offset below the first or above the last carrier frequency used	ACLR limit
±5 MHz	44,2 dB
±10 MHz	54,2 dB

If a BS provides multiple non-contiguous single carriers or multiple non-contiguous groups of contiguous single carriers, the above requirements shall be applied individually to the single carriers or group of single carriers.

#### 4.2.3.2.1.2 1,28 Mcps TDD option

The requirement shall apply to both Wide Area BS and Local Area BS. The ACLR of a single carrier BS or a multi-carrier BS with contiguous carrier frequencies shall be equal to or greater than the limits given in table 4.2.3.2.1.2-1.

**Table 4.2.3.2.1.2-1: BS ACLR limits (1,28 Mcps TDD option)**

BS adjacent channel offset below the first or above the last carrier frequency used	ACLR limit
±1,6 MHz	39,2 dB
±3,2 MHz	44,2 dB

If a BS provides multiple non-contiguous single carriers or multiple non-contiguous groups of contiguous single carriers, the above requirements shall be applied individually to the single carriers or group of single carriers.

#### 4.2.3.2.1.3 7,68 Mcps TDD option

The requirement shall apply to both Wide Area BS and Local Area BS. The ACLR of a single carrier BS or a multi-carrier BS with contiguous carrier frequencies shall be equal to or greater than the limits given in table 4.2.3.2.1.3-1.

**Table 4.2.3.2.1.3-1: BS ACLR limits (7,68 Mcps TDD option)**

BS adjacent channel offset below the first or above the last carrier frequency used	ACLR limit
±10 MHz	44,2 dB
±20 MHz	54,2 dB

If a BS provides multiple non-contiguous single carriers or multiple non-contiguous groups of contiguous single carriers, the above requirements shall be applied individually to the single carriers or group of single carriers.

### 4.2.3.2.2 Co-existence with UTRA-FDD

#### 4.2.3.2.2.1 3,84 Mcps TDD option

The requirement shall be applied for protection of UTRA FDD operating on the first or second adjacent channel. Different requirements shall apply to Wide Area BS and Local Area BS. The adjacent channel leakage power shall not exceed the limits specified in table 4.2.3.2.2.1-1.

**Table 4.2.3.2.2.1-1: Adjacent channel leakage power limits for protection of UTRA-FDD on adjacent channels (3,84 Mcps TDD option)**

Frequency Range for ACLR Measurement	BS class	BS adjacent channel offset	Maximum level	Measurement bandwidth
1 920 MHz to 1 930 MHz 2 560 MHz to 2 570 MHz 2 620 MHz to 2 630 MHz	Wide Area BS	±5 MHz	-36 dBm	3,84 MHz
	Wide Area BS	±10 MHz	-32 dBm	3,84 MHz
	Local Area BS	±5 MHz	-22,2 dBm	3,84 MHz
	Local Area BS	±10 MHz	-32,2 dBm	3,84 MHz

If a BS provides multiple non-contiguous single carriers or multiple non-contiguous groups of contiguous single carriers, the above requirements shall be applied to those adjacent channels of the single carriers or group of single channels.

#### 4.2.3.2.2.2 1,28 Mcps TDD option

The requirement shall be applied for protection of UTRA FDD operating on the first or second adjacent channel. This requirement is only applicable if the equipment is intended to operate at the highest carrier frequency in the range 1 916,2 MHz to 1 920 MHz in uncoordinated networks. Different requirements shall apply to Wide Area BS and Local Area BS. The adjacent channel leakage power shall not exceed the limits specified in table 4.2.3.2.2.2-1.

**Table 4.2.3.2.2.2-1: Adjacent channel leakage power limits for protection of UTRA-FDD on adjacent channels (1,28 Mcps TDD option)**

BS class	Centre frequency for measurement	Maximum level	Measurement bandwidth
Wide Area BS	1 922,6 MHz	-32 dBm	3,84 MHz
Local Area BS	1 922,6 MHz	-22,2 dBm	3,84 MHz

#### 4.2.3.2.2.3 7,68 Mcps TDD option

The requirement shall be applied for protection of UTRA FDD operating on the first or second adjacent channel. Different requirements shall apply to Wide Area BS and Local Area BS. The adjacent channel leakage power shall not exceed the limits specified in table 4.2.3.2.2.3-1.

**Table 4.2.3.2.2.3-1: Adjacent channel leakage power limits for protection of UTRA-FDD on adjacent channels (7,68 Mcps TDD option)**

BS Class	BS Adjacent Channel Offset	Maximum Level	Measurement Bandwidth
Wide Area BS	±7,5 MHz	-36 dBm	3,84 MHz
Wide Area BS	±12,5 MHz	-32 dBm	3,84 MHz
Wide Area BS	±17,5 MHz	-35 dBm	3,84 MHz
Wide Area BS	±22,5 MHz	-39 dBm	3,84 MHz
Local Area BS	±7,5 MHz	-22,2 dBm	3,84 MHz
Local Area BS	±12,5 MHz	-32,2 dBm	3,84 MHz
Local Area BS	±17,5 MHz	-35,2 dBm	3,84 MHz
Local Area BS	±22,5 MHz	-39,2 dBm	3,84 MHz

If a BS provides multiple non-contiguous single carriers or multiple non-contiguous groups of contiguous single carriers, the above requirements shall be applied to those adjacent channels of the single carriers or group of single channels.

#### 4.2.3.2.3 Co-existence with unsynchronized UTRA TDD on adjacent channels

##### 4.2.3.2.3.1 3,84 Mcps TDD option

The requirement shall be applied for protection of unsynchronized UTRA TDD operating on the first or second adjacent channel. Different requirements shall apply to Wide Area BS and Local Area BS. The adjacent channel leakage power shall not exceed the limits specified in table 4.2.3.2.3.1-1.

**Table 4.2.3.2.3.1-1: Adjacent channel leakage power limits for protection of unsynchronized UTRA-TDD on adjacent channels (3,84 Mcps TDD option)**

BS Class	BS adjacent channel offset below the first or above the last carrier frequency used	Maximum Level	Measurement Bandwidth
Wide Area BS	5 MHz	-25 dBm	3,84 MHz
Wide Area BS	10 MHz	-25 dBm	3,84 MHz
Local Area BS	5 MHz	-15,2 dBm	3,84 MHz
Local Area BS	10 MHz	-25,2 dBm	3,84 MHz

If a BS provides multiple non-contiguous single carriers or multiple non-contiguous groups of contiguous single carriers, the above requirements shall be applied to those adjacent channels of the single carriers or group of single channels.

#### 4.2.3.2.3.2 1,28 Mcps TDD option

The requirement shall be applied for protection of unsynchronized UTRA TDD operating on the first or second adjacent channel. Different requirements shall apply to Wide Area BS and Local Area BS. The adjacent channel leakage power shall not exceed the limits specified in table 4.2.3.2.3.2-1.

**Table 4.2.3.2.3.2-1: Adjacent channel leakage power limits for protection of unsynchronized UTRA-TDD on adjacent channels (1,28 Mcps TDD option)**

BS Class	BS Adjacent Channel Offset	Maximum Level	Measurement Bandwidth
Wide Area BS	$\pm 1,6$ MHz	-28 dBm	1,28 MHz
Wide Area BS	$\pm 3,2$ MHz	-28 dBm	1,28 MHz
Wide Area BS	$\pm 3,4$ MHz	-28 dBm	3,84 MHz
Local Area BS	$\pm 1,6$ MHz	-15,2 dBm	1,28 MHz
Local Area BS	$\pm 3,2$ MHz	-15,2 dBm	1,28 MHz
Local Area BS	$\pm 3,4$ MHz	-15,2 dBm	3,84 MHz

If a BS provides multiple non-contiguous single carriers or multiple non-contiguous groups of contiguous single carriers, the above requirements shall be applied to those adjacent channels of the single carriers or group of single channels.

#### 4.2.3.2.3.3 7,68 Mcps TDD option

The requirement shall be applied for protection of unsynchronized UTRA TDD operating on the first or second adjacent channel. Different requirements shall apply to Wide Area BS and Local Area BS. The adjacent channel leakage power shall not exceed the limits specified in table 4.2.3.2.3.3-1 and 7g.

**Table 4.2.3.2.3.3-1: Adjacent channel leakage power limits for protection of unsynchronized 3,84 Mcps UTRA-TDD on adjacent channels (7,68 Mcps TDD option)**

BS Class	BS adjacent channel offset below the first or above the last carrier frequency used	Maximum Level	Measurement Bandwidth
Wide Area BS	7,5 MHz	-25 dBm	3,84 MHz
Wide Area BS	12,5 MHz	-25 dBm	3,84 MHz
Wide Area BS	17,5 MHz	-25 dBm	3,84 MHz
Wide Area BS	22,5 MHz	-25 dBm	3,84 MHz
Local Area BS	7,5 MHz	-15,2 dBm	3,84 MHz
Local Area BS	12,5 MHz	-25,2 dBm	3,84 MHz
Local Area BS	17,5 MHz	-25,2 dBm	3,84 MHz
Local Area BS	22,5 MHz	-25,2 dBm	3,84 MHz

**Table 4.2.3.2.3.3-2: Adjacent channel leakage power limits for protection of unsynchronized 1,28 Mcps UTRA-TDD on adjacent channels (7,68 Mcps TDD option)**

BS Class	BS adjacent channel offset below the first or above the last carrier frequency used	Maximum Level	Measurement Bandwidth
Wide Area BS	5,8 MHz	-28 dBm	1,28 MHz
Wide Area BS	7,4 MHz	-28 dBm	1,28 MHz
Local Area BS	5,8 MHz	-15,2 dBm	1,28 MHz
Local Area BS	7,4 MHz	-15,2 dBm	1,28 MHz

If a BS provides multiple non-contiguous single carriers or multiple non-contiguous groups of contiguous single carriers, the above requirements shall be applied to those adjacent channels of the single carriers or group of single channels.

### 4.2.3.3 Conformance

Conformance tests described in clause 5.3.2 shall be carried out.

## 4.2.4 Transmitter spurious emissions

### 4.2.4.1 Definition

Transmitter spurious emissions are emissions which are caused by unwanted transmitter effects such as harmonics emission, parasitic emission, intermodulation products and frequency conversion products, but exclude out of band emissions. This is measured at the Base Station RF output port.

Unless otherwise stated, all requirements are measured as mean power.

### 4.2.4.2 Limits

#### 4.2.4.2.1 General requirements

The requirements shall apply to both Wide Area BS and Local Area BS.

##### 4.2.4.2.1.1 3,84 Mcps TDD option

The requirements of table 4.2.4.2.1.1-1 shall apply whatever the type of transmitter considered (single carrier or multi-carrier). It applies for all transmission modes foreseen by the manufacturer.

These requirements apply at frequencies within the specified frequency ranges which are more than 12,5 MHz under the first carrier frequency used or more than 12,5 MHz above the last carrier frequency used.

The power of any spurious emission shall not exceed the maximum levels given in table 4.2.4.2.1.1-1.

**Table 4.2.4.2.1.1-1: BS Mandatory spurious emissions limits (3,84 Mcps TDD option)**

Band	Maximum Level	Measurement Bandwidth	Notes
9 kHz to 150 kHz	-36 dBm	1 kHz	Note 3
150 kHz to 30 MHz	-36 dBm	10 kHz	Note 3
30 MHz to 1 GHz	-36 dBm	100 kHz	Note 3
1 GHz to FI - 10 MHz	-30 dBm	1 MHz	Note 3
FI - 10 MHz to Fu + 10 MHz	-15 dBm	1 MHz	Note 4
Fu + 10 MHz to 12,75 GHz	-30 dBm	1 MHz	Note 5

NOTE 1: FI: Lower frequency of the band in which TDD operates.  
 NOTE 2: Fu: Upper frequency of the band in which TDD operates.  
 NOTE 3: Bandwidth as in ITU-R Recommendation SM.329-10 [4], section 4.1.  
 NOTE 4: Limit based on ITU-R Recommendation SM.329-10 [4], section 4.3 and annex 7.  
 NOTE 5: Bandwidth as in ITU-R Recommendation SM.329-10 [4], section 4.3 and annex 7.  
 Upper frequency as in ITU-R Recommendation SM.329-10 [4], section 2.5 table 1-1.

## 4.2.4.2.1.2 1,28 Mcps TDD option

The requirements of table 4.2.4.2.1.2-1 shall apply whatever the type of transmitter considered (single carrier or multi-carrier). It applies for all transmission modes foreseen by the manufacturer.

These requirements apply at frequencies within the specified frequency ranges which are more than 4 MHz under the first carrier frequency used or more than 4 MHz above the last carrier frequency used.

The power of any spurious emission shall not exceed the maximum levels given in table 4.2.4.2.1.2-1.

**Table 4.2.4.2.1.2-1: BS mandatory spurious emissions limits (1,28 Mcps TDD option)**

Band	Maximum Level	Measurement Bandwidth	Notes
9 kHz to 150 kHz	-36 dBm	1 kHz	Note 3
150 kHz to 30 MHz	-36 dBm	10 kHz	Note 3
30 MHz to 1 GHz	-36 dBm	100 kHz	Note 3
1 GHz to FI - 10 MHz	-30 dBm	1 MHz	Note 3
FI - 10 MHz to Fu + 10 MHz	-15 dBm	1 MHz	Note 4
Fu + 10 MHz to 12,5 GHz	-30 dBm	1 MHz	Note 5
NOTE 1: FI: Lower frequency of the band in which TDD operates.			
NOTE 2: Fu: Upper frequency of the band in which TDD operates.			
NOTE 3: Bandwidth as in ITU-R Recommendation SM.329-10 [4], section 4.1.			
NOTE 4: Limit based on ITU-R Recommendation SM.329-10 [4], section 4.3 and annex 7.			
NOTE 5: Bandwidth as in ITU-R Recommendation SM.329-10 [4], section 4.3 and annex 7. Upper frequency as in ITU-R Recommendation SM.329-10 [4], section 2.5 table 1-1.			

## 4.2.4.2.1.3 7,68 Mcps TDD option

The requirements of table 4.2.4.2.1.3-1 shall apply whatever the type of transmitter considered (single carrier or multi-carrier). It applies for all transmission modes foreseen by the manufacturer.

These requirements apply at frequencies within the specified frequency ranges which are more than 25 MHz under the first carrier frequency used or more than 25 MHz above the last carrier frequency used.

The power of any spurious emission shall not exceed the maximum levels given in table 4.2.4.2.1.3-1.

**Table 4.2.4.2.1.3-1: BS Mandatory spurious emissions limits (7,68 Mcps TDD option)**

Band	Maximum Level	Measurement Bandwidth	Notes
9 kHz to 150 kHz	-36 dBm	1 kHz	Note 3
150 kHz to 30 MHz	-36 dBm	10 kHz	Note 3
30 MHz to 1 GHz	-36 dBm	100 kHz	Note 3
1 GHz to FI - 10 MHz	-30 dBm	1 MHz	Note 3
FI - 10 MHz to Fu + 10 MHz	-15 dBm	1 MHz	Note 4
Fu + 10 MHz to 12,75 GHz	-30 dBm	1 MHz	Note 5
NOTE 1: FI: Lower frequency of the band in which TDD operates.			
NOTE 1: Fu: Upper frequency of the band in which TDD operates.			
NOTE 3: Bandwidth as in ITU-R Recommendation SM.329-10 [4], section 4.1.			
NOTE 4: Limit based on ITU-R Recommendation SM.329-10 [4], section 4.3 and annex 7.			
NOTE 5: Bandwidth as in ITU-R Recommendation SM.329-10 [4], section 4.3 and annex 7. Upper frequency as in ITU-R Recommendation SM.329-10 [4], section 2.5 table 1-1.			

## 4.2.4.2.2 Co-existence with GSM900

This requirement shall be applied for the protection of GSM900 MS and GSM900 BTS receivers. The requirement shall apply to both Wide Area BS and Local Area BS. The power of any spurious emission shall not exceed the maximum levels given in table 4.2.4.2.2-1.

**Table 4.2.4.2.2-1: BS spurious emissions limits for protection of GSM900 MS and GSM900 BTS receiver**

Band	Maximum level	Measurement bandwidth
876 MHz to 915 MHz	-61 dBm	100 kHz
921 MHz to 960 MHz	-57 dBm	100 kHz

#### 4.2.4.2.3 Co-existence with DCS1800

This requirement shall be applied for the protection of DCS1800 MS and DCS1800 BTS receivers. The requirement shall apply to both Wide Area BS and Local Area BS. The power of any spurious emission shall not exceed the maximum levels given in table 4.2.4.2.3-1.

**Table 4.2.4.2.3-1: BS spurious emissions limits for protection of DCS1800 MS and DCS1800 BTS receiver**

Band	Maximum level	Measurement bandwidth
1 710 MHz to 1 785 MHz	-61 dBm	100 kHz
1 805 MHz to 1 880 MHz	-47 dBm	100 kHz

#### 4.2.4.2.4 Co-existence with UTRA FDD

This requirement shall be applied for protection of UTRA FDD. Different requirements shall apply to Wide Area BS and Local Area BS. For TDD Base Stations which use carrier frequencies within the band 2 010 MHz to 2 025 MHz the requirements applies at all frequencies within the specified frequency bands in table 4.2.4.2.4-1. For 3,84 Mcps TDD option Base Stations which use a carrier frequency within the band from 1 900 MHz to 1 920 MHz, the requirement applies at frequencies within the specified frequency range which are more than 12,5 MHz above the last carrier used in the frequency band from 1 900 MHz to 1 920 MHz. For 1,28 Mcps TDD option Base Stations which use carrier frequencies within the band from 1 900 MHz to 1 920 MHz, the requirement applies at frequencies within the specified frequency range which are more than 4 MHz above the last carrier used in the frequency band from 1 900 MHz to 1 920 MHz. For 7,68 Mcps TDD option Base Stations which use a carrier frequency within the band from 1 900 MHz to 1 920 MHz the requirement applies at frequencies within the specified frequency range which are more than 25 MHz above the last carrier used in the frequency band from 1 900 MHz to 1 920 MHz. The power of any spurious emission shall not exceed the maximum levels given in table 4.2.4.2.4-1.

**Table 4.2.4.2.4-1: BS spurious emissions limits for protection of UTRA FDD receiver**

BS class	Band	Maximum level	Measurement bandwidth	Notes
Wide Area BS	1 920 MHz to 1 980 MHz	-43 dBm	3,84 MHz	Note 1
Wide Area BS	2 110 MHz to 2 170 MHz	-52 dBm	1 MHz	
Wide Area BS	2 500 MHz to 2 570 MHz	-43 dBm	3,84 MHz	Note 2
Wide Area BS	2 620 MHz to 2 690 MHz	-52 dBm	1 MHz	
Local Area BS	1 920 MHz to 1 980 MHz	-40 dBm	3,84 MHz	Note 1
Local Area BS	2 110 MHz to 2 170 MHz	-52 dBm	1 MHz	
Local Area BS	2 500 MHz to 2 570 MHz	-40 dBm	3,84 MHz	Note 2
Local Area BS	2 620 MHz to 2 690 MHz	-52 dBm	1 MHz	

BS class	Band	Maximum level	Measurement bandwidth	Notes
<p>NOTE 1: For 3,84 Mcps TDD option Base Stations which use carrier frequencies within the band 1 900 MHz to 1 920 MHz, the requirement shall be measured RRC filtered mean power with the lowest centre frequency of measurement at 1 922,6 MHz or 15 MHz above the last TDD carrier used, whichever is higher. For 1,28 Mcps TDD option Base Stations which use carrier frequencies within the band 1 900 MHz to 1 920 MHz, the requirement shall be measured RRC filtered mean power with the lowest centre frequency of measurement at 1 922,6 MHz or 6,6 MHz above the last TDD carrier used, whichever is higher. For 7,68 Mcps TDD option Base Stations which use carrier frequencies within the band 1 900 MHz to 1 920 MHz, the requirement shall be measured RRC filtered mean power with the lowest centre frequency of measurement at 1 922,6 MHz or 30 MHz above the highest TDD carrier used, whichever is higher.</p> <p>NOTE 2: For 3,84 Mcps TDD option Base Stations which use carrier frequencies within the band 2 570 MHz to 2 620 MHz, the requirement shall be measured RRC filtered mean power with the lowest centre frequency of measurement at 2 567,5 MHz or 15 MHz below the last TDD carrier used, whichever is lower. For 1,28 Mcps TDD option Base Stations which use carrier frequencies within the band 2 570 MHz to 2 620 MHz, the requirement shall be measured RRC filtered mean power with the lowest centre frequency of measurement at 2 567,5 MHz or 6,6 MHz below the last TDD carrier used, whichever is lower. For 7,68 Mcps TDD option Base Stations which use carrier frequencies within the band 2 570 MHz to 2 620 MHz, the requirement shall be measured RRC filtered mean power with the highest centre frequency of measurement at 2 567,5 MHz or 30 MHz below the lowest TDD carrier used, whichever is lower.</p>				

#### 4.2.4.2.5 Co-existence with unsynchronized TDD

This requirement shall be applied for protection of unsynchronized UTRA TDD. Different requirements shall apply to Wide Area BS and Local Area BS. The RRC filtered mean power of any spurious emission shall not exceed the maximum levels given in table 4.2.4.2.5-1.

**Table 4.2.4.2.5-1: BS spurious emissions limits for protection of unsynchronized TDD**

BS Class	Band	Maximum level	Measurement bandwidth
Wide Area BS	1 900 MHz to 1 920 MHz	-39 dBm	3,84 MHz
Wide Area BS	2 010 MHz to 2 025 MHz	-39 dBm	3,84 MHz
Wide Area BS	2 570 MHz to 2 620 MHz	-39 dBm	3,84 MHz
Local Area BS	1 900 MHz to 1 920 MHz	-36 dBm	3,84 MHz
Local Area BS	2 010 MHz to 2 025 MHz	-36 dBm	3,84 MHz
Local Area BS	2 570 MHz to 2 620 MHz	-36 dBm	3,84 MHz

#### 4.2.4.3 Conformance

Conformance tests described in clause 5.3.3 shall be carried out.

### 4.2.5 Base station maximum output power

#### 4.2.5.1 Definition

The "Base Station maximum output power" (P<sub>max</sub>) requirement is defined relative to the "rated output power". Maximum output power (P<sub>max</sub>) and rated output power (PRAT) are defined in clause 3.1.

#### 4.2.5.2 Limits

The requirement shall apply to both Wide Area BS and Local Area BS.

In normal conditions, the measured output power, derived according to clause 5.3.4.1.2, shall remain within +2,7 dB and -2,7 dB of the manufacturer's rated output power.

In extreme conditions, the measured output power, derived according to clause 5.3.4.1.2, shall remain within +3,2 dB and -3,2 dB of the manufacturer's rated output power.

### 4.2.5.3 Conformance

Conformance tests described in clause 5.3.4 shall be carried out.

## 4.2.6 Transmit intermodulation

### 4.2.6.1 Definition

The transmit intermodulation performance is a measure of the capability of the transmitter to inhibit the generation of signals in its non linear elements caused by presence of the wanted signal and an interfering signal reaching the transmitter via the antenna.

### 4.2.6.2 Limits

#### 4.2.6.2.1 3,84 Mcps TDD option

The transmit intermodulation level is the power of the intermodulation products when a WCDMA modulated interference signal is injected into the antenna connector at a level of 30 dB lower than that of the subject signal. The requirements are applicable for a single carrier. The frequency of the interference signal shall be  $\pm 5$  MHz,  $\pm 10$  MHz and  $\pm 15$  MHz offset from the subject signal but excluding interference carrier frequencies outside of the frequency bands 1 900 MHz to 1 920 MHz, 2 010 MHz to 2 025 MHz and 2 570 MHz to 2 620 MHz.

The requirement shall apply to both Wide Area BS and Local Area BS.

The transmit intermodulation level shall not exceed the spectrum emission mask requirements, the transmitter adjacent channel leakage power ratio requirement and the transmitter spurious emission requirements, described in clauses 4.2.2.2.1, 4.2.3.2.1, 4.2.4.2.1.1, 4.2.4.2.2 to 4.2.4.2.4 respectively.

#### 4.2.6.2.2 1,28 Mcps TDD option

The transmit intermodulation level is the power of the intermodulation products when a CDMA modulated interference signal is injected into the antenna connector at a level of 30 dB lower than that of the subject signal. The requirements are applicable for a single carrier. The frequency of the interference signal shall be  $\pm 1,6$  MHz,  $\pm 3,2$  MHz and  $\pm 4,8$  MHz offset from the subject signal but excluding interference carrier frequencies outside of the frequency bands 1 900 MHz to 1 920 MHz, 2 010 MHz to 2 025 MHz and 2 570 MHz to 2 620 MHz.

The requirement shall apply to both Wide Area BS and Local Area BS.

The transmit intermodulation level shall not exceed the spectrum emission mask requirements, the transmitter adjacent channel leakage power ratio requirement and the transmitter spurious emission requirements, described in clauses 4.2.2.2.2, 4.2.3.2.1, 4.2.4.2.1.2, 4.2.4.2.2, 4.2.4.2.3 and 4.2.4.2.4 respectively.

#### 4.2.6.2.3 7,68 Mcps TDD option

The transmit intermodulation level is the power of the intermodulation products when a WCDMA modulated interference signal is injected into the antenna connector at a level of 30 dB lower than that of the subject signal. The requirements are applicable for a single carrier. The frequency of the interference signal shall be  $\pm 10$  MHz,  $\pm 20$  MHz and  $\pm 30$  MHz offset from the subject signal but excluding interference carrier frequencies outside of the frequency bands 1 900 MHz to 1 920 MHz, 2 010 MHz to 2 025 MHz and 2 570 MHz to 2 620 MHz.

The requirement shall apply to both Wide Area BS and Local Area BS.

The transmit intermodulation level shall not exceed the spectrum emission mask requirements, the transmitter adjacent channel leakage power ratio requirement and the transmitter spurious emission requirements, described in clauses 4.2.2.2.3, 4.2.3.2.1, 4.2.4.2.1.3, 4.2.4.2.2 to 4.2.4.2.4 respectively.

### 4.2.6.3 Conformance

Conformance tests described in clause 5.3.5 shall be carried out.



## 4.2.7 Receiver spurious emissions

### 4.2.7.1 Definition

The spurious emissions power is the power of emissions, generated or amplified in a receiver, which appear at the BS antenna connector. The requirements apply to all BS with separate Rx and Tx antenna port. The test shall be performed when both Tx and Rx are on with the Tx port terminated.

For BS equipped with only a single antenna connector for both transmitter and receiver, the requirements of clause 4.2.4 Transmitter spurious emissions shall apply to this port, and this test need not be performed.

### 4.2.7.2 Limits

The requirement shall apply to both Wide Area BS and Local Area BS.

#### 4.2.7.2.1 3,84 Mcps TDD option

The power of any spurious emission shall not exceed the values given in table 4.2.7.2.1-1.

**Table 4.2.7.2.1-1: Receiver spurious emission requirements (3,84 Mcps TDD option)**

Band	Maximum level	Measurement bandwidth	Notes
30 MHz to 1 GHz	-57 dBm	100 kHz	-
1 GHz to 1,9 GHz	-47 dBm	1 MHz	Note
1 900 GHz to 1 980 GHz	-78 dBm	3,84 MHz	Note
1 980 GHz to 2 010 GHz	-47 dBm	1 MHz	Note
2 010 GHz to 2 025 GHz	-78 dBm	3,84 MHz	Note
2 025 GHz to 2 500 GHz	-47 dBm	1 MHz	Note
2 500 GHz to 2 620 GHz	-78 dBm	3,84 MHz	Note
2 620 GHz to 12,75 GHz	-47 dBm	1 MHz	Note

NOTE: With the exception of frequencies between 12,5 MHz below the first carrier frequency and 12,5 MHz above the last carrier frequency used by the BS.

#### 4.2.7.2.2 1,28 Mcps TDD option

The power of any spurious emission shall not exceed the values given in table 4.2.7.2.2-1.

**Table 4.2.7.2.2-1: Receiver spurious emission requirements (1,28 Mcps TDD option)**

Band	Maximum level	Measurement Bandwidth	Notes
30 MHz to 1 GHz	-57 dBm	100 kHz	-
1 GHz to 1,9 GHz	-47 dBm	1 MHz	Note
1 900 GHz to 1 980 GHz	-83 dBm	1,28 MHz	Note
1 980 GHz to 2 010 GHz	-47 dBm	1 MHz	Note
2 010 GHz to 2 025 GHz	-83 dBm	1,28 MHz	Note
2 025 GHz to 2 500 GHz	-47 dBm	1 MHz	Note
2 500 GHz to 2 620 GHz	-83 dBm	1,28 MHz	Note
2 620 GHz to 12,75 GHz	-47 dBm	1 MHz	Note

NOTE: With the exception of frequencies between 4 MHz below the first carrier frequency and 4 MHz above the last carrier frequency used by the BS.

#### 4.2.7.2.3 7,68 Mcps TDD option

The power of any spurious emission shall not exceed the values given in table 4.2.7.2.3-1.

**Table 4.2.7.2.3-1: Receiver spurious emission requirements (7,68 Mcps TDD option)**

Band	Maximum level	Measurement bandwidth	Notes
30 MHz to 1 GHz	-57 dBm	100 kHz	-
1 GHz to 1,9 GHz	-47 dBm	1 MHz	Note
1 900 GHz to 1 980 GHz	-75 dBm	7,68 MHz	Note
1 980 GHz to 2 010 GHz	-47 dBm	1 MHz	Note
2 010 GHz to 2 025 GHz	-75 dBm	7,68MHz	Note
2 025 GHz to 2 500 GHz	-47 dBm	1 MHz	Note
2 500 GHz to 2 620 GHz	-75 dBm	7,68 MHz	Note
2 620 GHz to 12,75 GHz	-47 dBm	1 MHz	Note

NOTE: With the exception of frequencies between 25 MHz below the first carrier frequency and 25 MHz above the last carrier frequency used by the BS.

### 4.2.7.3 Conformance

Conformance tests described in clause 5.3.6 shall be carried out.

## 4.2.8 Receiver blocking characteristics

### 4.2.8.1 Definition

The blocking characteristics are a measure of the receiver ability to receive a wanted signal at its assigned channel frequency in the presence of an unwanted interferer on frequencies other than those of the adjacent channels.

### 4.2.8.2 Limits

#### 4.2.8.2.1 3,84 Mcps TDD option

Different requirements shall apply to Wide Area BS and Local Area BS. The blocking requirements apply to interfering signals with centre frequency within the ranges specified in table 4.2.8.2.1-1 (for operating band a) and table 4.2.8.2.1-3 (for operating band d) for the Wide Area BS and table 4.2.8.2.1-2 (for operating band a) and table 4.2.8.2.1-4 (for operating band d) for the Local Area BS respectively, using a 1 MHz step size.

Using the UL reference measurement channel (12,2 kbit/s) defined in TS 125 105 [2], annex A the BER of this wanted signal shall not exceed 0,001 in the presence of an interfering signal. This static reference performance shall be met with a wanted and an interfering signal coupled to the BS antenna input using the parameters specified in table 4.2.8.2.1-1 (for operating band a) and table 4.2.8.2.1-3 (for operating band d) for the Wide Area BS and table 4.2.8.2.1-2 (for operating band d) and table 4.2.8.2.1-4 (for operating band d) for the Local Area BS respectively.

**Table 4.2.8.2.1-1: Blocking requirements for Wide Area BS (3,84 Mcps TDD option) for operating band a**

Centre frequency of interfering signal	Interfering signal mean power	Wanted signal mean power	Minimum offset of interfering signal	Type of interfering signal
1 900 MHz to 1 920 MHz 2 010 MHz to 2 025 MHz	-40 dBm	-103 dBm	10 MHz	WCDMA signal with one code
1 880 MHz to 1 900 MHz 1 990 MHz to 2 010 MHz 2 025 MHz to 2 045 MHz	-40 dBm	-103 dBm	10 MHz	WCDMA signal with one code
1 920 MHz to 1 980 MHz	-40 dBm	-103 dBm	10 MHz	WCDMA signal with one code
1 MHz to 1 880 MHz 1 980 MHz to 1 990 MHz 2 045 MHz to 12 750 MHz	-15 dBm	-103 dBm	-	CW carrier

**Table 4.2.8.2.1-2: Blocking requirements for Local Area BS (3,84 Mcps TDD option)  
for operating band a**

Centre frequency of interfering signal	Interfering signal mean power	Wanted signal mean power	Minimum offset of interfering signal	Type of interfering signal
1 900 MHz to 1 920 MHz 2 010 MHz to 2 025 MHz	-30 dBm	-89 dBm	10 MHz	WCDMA signal with one code
1 880 MHz to 1 900 MHz 1 990 MHz to 2 010 MHz 2 025 MHz to 2 045 MHz	-30 dBm	-89 dBm	10 MHz	WCDMA signal with one code
1 920 MHz to 1 980 MHz	-30 dBm	-89 dBm	10 MHz	WCDMA signal with one code
1 MHz to 1 880 MHz 1 980 MHz to 1 990 MHz 2 045 MHz to 12 750 MHz	-15 dBm	-89 dBm	-	CW carrier

**Table 4.2.8.2.1-3: Blocking requirements for Wide Area BS (3,84 Mcps TDD option)  
for operating band d**

Centre frequency of interfering signal	Interfering signal mean power	Wanted signal mean power	Minimum offset of interfering signal	Type of interfering signal
2 570 MHz to 2 620 MHz	-40 dBm	-103 dBm	10 MHz	WCDMA signal with one code
2 500 MHz to 2 570 MHz 2 620 MHz to 2 690 MHz	-40 dBm	-103 dBm	10 MHz	WCDMA signal with one code
1 MHz to 2 550 MHz 2 690 MHz to 12 750 MHz	-15 dBm	-103 dBm	-	CW carrier

**Table 4.2.8.2.1-4: Blocking requirements for Local Area BS (3,84 Mcps TDD option)  
for operating band d**

Centre frequency of interfering signal	Interfering signal mean power	Wanted signal mean power	Minimum offset of interfering signal	Type of interfering signal
2 570 MHz to 2 620 MHz	-30 dBm	-89 dBm	10 MHz	WCDMA signal with one code
2 500 MHz to 2 570 MHz 2 620 MHz to 2 690 MHz	-30 dBm	-89 dBm	10 MHz	WCDMA signal with one code
1 MHz to 2 550 MHz 2 690 MHz to 12 750 MHz	-15 dBm	-89 dBm	-	CW carrier

#### 4.2.8.2.2 1,28 Mcps TDD option

Different requirements shall apply to Wide Area BS and Local Area BS. The blocking requirements apply to interfering signals with centre frequency within the ranges specified in table 4.2.8.2.2-1 (for operating band a) and table 4.2.8.2.2-3 (for operating band d) for the Wide Area BS and table 4.2.8.2.2-2 (for operating band a) and table 4.2.8.2.2-4 (for operating band d) for the Local Area BS respectively, using a 1 MHz step size.

Using the UL reference measurement channel (12,2 kbit/s) defined in TS 125 105 [2], annex A the BER of this wanted signal shall not exceed 0,001 in the presence of an interfering signal. This static reference performance shall be met with a wanted and an interfering signal coupled to the BS antenna input using the parameters specified in table 4.2.8.2.2-1 (for operating band a) and table 4.2.8.2.2-3 (for operating band d) for the Wide Area BS and table 4.2.8.2.2-2 (for operating band a) and table 4.2.8.2.2-4 (for operating band d) for the Local Area BS respectively.

**Table 4.2.8.2.2-1: Blocking requirements for Wide Area BS (1,28 Mcps TDD option)  
for operating band a**

Centre frequency of interfering signal	Interfering signal mean power	Wanted signal mean power	Minimum offset of interfering signal	Type of interfering signal
1 900 MHz to 1 920 MHz 2 010 MHz to 2 025 MHz	-40 dBm	-104 dBm	3,2 MHz	1,28 Mcps TDD signal with one code
1 880 MHz to 1 900 MHz 1 990 MHz to 2 010 MHz 2 025 MHz to 2 045 MHz	-40 dBm	-104 dBm	3,2 MHz	1,28 Mcps TDD signal with one code
1 920 MHz to 1 980 MHz	-40 dBm	-104 dBm	3,2 MHz	1,28 Mcps TDD signal with one code
1 MHz to 1 880 MHz 1 980 MHz to 1 990 MHz 2 045 MHz to 12 750 MHz	-15 dBm	-104 dBm	-	CW carrier

**Table 4.2.8.2.2-2: Blocking requirements for Local Area BS (1,28 Mcps TDD option)  
for operating band a**

Centre frequency of interfering signal	Interfering signal mean power	Wanted signal mean power	Minimum offset of interfering signal	Type of interfering signal
1 900 MHz to 1 920 MHz 2 010 MHz to 2 025 MHz	-30 dBm	-90 dBm	3,2 MHz	1,28 Mcps TDD signal with one code
1 880 MHz to 1 900 MHz 1 990 MHz to 2 010 MHz 2 025 MHz to 2 045 MHz	-30 dBm	-90 dBm	3,2 MHz	1,28 Mcps TDD signal with one code
1 920 MHz to 1 980 MHz	-30 dBm	-90 dBm	3,2 MHz	1,28 Mcps TDD signal with one code
1 MHz to 1 880 MHz 1 980 MHz to 1 990 MHz 2 045 MHz to 12 750 MHz	-15 dBm	-90 dBm	-	CW carrier

**Table 4.2.8.2.2-3: Blocking requirements for Wide Area BS (1,28 Mcps TDD option)  
for operating band d**

Centre frequency of interfering signal	Interfering signal mean power	Wanted signal mean power	Minimum offset of interfering signal	Type of interfering signal
2 570 MHz to 2 620 MHz	-40 dBm	-104 dBm	3,2 MHz	1,28 Mcps TDD signal with one code
2 500 MHz to 2 570 MHz 2 620 MHz to 2 690 MHz	-40 dBm	-104 dBm	3,2 MHz	1,28 Mcps TDD signal with one code
1 MHz to 2 550 MHz 2 690 MHz to 12 750 MHz	-15 dBm	-104 dBm	-	CW carrier

**Table 4.2.8.2.2-4: Blocking requirements for Local Area BS (1,28 Mcps TDD option)  
for operating band d**

Centre frequency of interfering signal	Interfering signal mean power	Wanted signal mean power	Minimum offset of interfering signal	Type of interfering signal
2 570 MHz to 2 620 MHz	-30 dBm	-90 dBm	3,2 MHz	1,28 Mcps TDD signal with one code
2 500 MHz to 2 570 MHz 2 620 MHz to 2 690 MHz	-30 dBm	-90 dBm	3,2 MHz	1,28 Mcps TDD signal with one code
1 MHz to 2 550 MHz 2 690 MHz to 12 750 MHz	-15 dBm	-90 dBm	-	CW carrier

## 4.2.8.2.3 7,68 Mcps TDD option

Different requirements shall apply to Wide Area BS and Local Area BS. The blocking requirements apply to interfering signals with centre frequency within the ranges specified in table 4.2.8.2.3-1 (for operating band a) and table 4.2.8.2.3-3 (for operating band d) for the Wide Area BS and table 4.2.8.2.3-2 (for operating band a) and table 4.2.8.2.3-4 (for operating band d) for the Local Area BS respectively, using a 1 MHz step size.

Using the UL reference measurement channel (12,2 kbit/s) defined in TS 125 105 [2], annex A the BER of this wanted signal shall not exceed 0,001 in the presence of an interfering signal. This static reference performance shall be met with a wanted and an interfering signal coupled to the BS antenna input using the parameters specified in table 4.2.8.2.3-1 (for operating band a) and table 4.2.8.2.3-3 (for operating band d) for the Wide Area BS and table 4.2.8.2.3-2 (for operating band d) and table 4.2.8.2.3-4 (for operating band d) for the Local Area BS respectively.

**Table 4.2.8.2.3-1: Blocking requirements for Wide Area BS (7,68 Mcps TDD option) for operating band a**

Centre frequency of interfering signal	Interfering signal mean power	Wanted signal mean power	Minimum offset of interfering signal	Type of interfering signal
1 900 MHz to 1 920 MHz 2 010 MHz to 2 025 MHz	-40 dBm	-103 dBm	20 MHz	WCDMA signal with one code
1 880 MHz to 1 900 MHz 1 990 MHz to 2 010 MHz 2 025 MHz to 2 045 MHz	-40 dBm	-103 dBm	20 MHz	WCDMA signal with one code
1 920 MHz to 1 980 MHz	-40 dBm	-103 dBm	20 MHz	WCDMA signal with one code
1 MHz to 1 880 MHz 1 980 MHz to 1 990 MHz 2 045 MHz to 12 750 MHz	-15 dBm	-103 dBm	-	CW carrier

**Table 4.2.8.2.3-2: Blocking requirements for Local Area BS (7,68 Mcps TDD option) for operating band a**

Centre frequency of interfering signal	Interfering signal mean power	Wanted signal mean power	Minimum offset of interfering signal	Type of interfering signal
1 900 MHz to 1 920 MHz 2 010 MHz to 2 025 MHz	-30 dBm	-89 dBm	20 MHz	WCDMA signal with one code
1 880 MHz to 1 900 MHz 1 990 MHz to 2 010 MHz 2 025 MHz to 2 045 MHz	-30 dBm	-89 dBm	20 MHz	WCDMA signal with one code
1 920 MHz to 1 980 MHz	-30 dBm	-89 dBm	20 MHz	WCDMA signal with one code
1 MHz to 1 880 MHz 1 980 MHz to 1 990 MHz 2 045 MHz to 12 750 MHz	-15 dBm	-89 dBm	-	CW carrier

**Table 4.2.8.2.3-3: Blocking requirements for Wide Area BS (7,68 Mcps TDD option) for operating band d**

Centre frequency of interfering signal	Interfering signal mean power	Wanted signal mean power	Minimum offset of interfering signal	Type of interfering signal
2 570 MHz to 2 620 MHz	-40 dBm	-103 dBm	20 MHz	WCDMA signal with one code
2 500 MHz to 2 570 MHz 2 620 MHz to 2 690 MHz	-40 dBm	-103 dBm	20 MHz	WCDMA signal with one code
1 MHz to 2 550 MHz 2 690 MHz to 12 750 MHz	-15 dBm	-103 dBm	-	CW carrier

**Table 4.2.8.2.3-4: Blocking requirements for Local Area BS (7,68 Mcps TDD option)  
for operating band d**

Centre frequency of interfering signal	Interfering signal mean power	Wanted signal mean power	Minimum offset of interfering signal	Type of interfering signal
2 570 MHz to 2 620 MHz	-30 dBm	-89 dBm	20 MHz	WCDMA signal with one code
2 500 MHz to 2 570 MHz 2 620 MHz to 2 690 MHz	-30 dBm	-89 dBm	20 MHz	WCDMA signal with one code
1 MHz to 2 550 MHz 2 690 MHz to 12 750 MHz	-15 dBm	-89 dBm	-	CW carrier

### 4.2.8.3 Conformance

Conformance tests described in clause 5.3.7 shall be carried out.

## 4.2.9 Receiver intermodulation characteristics

### 4.2.9.1 Definition

Third and higher order mixing of two interfering RF signals can produce an interfering signal in the band of the desired channel. Intermodulation response rejection is a measure of the capability of the receiver to receive a wanted signal on its assigned channel frequency in the presence of two or more interfering signals which have a specific frequency relationship to the wanted signal.

### 4.2.9.2 Limits

#### 4.2.9.2.1 3,84 Mcps TDD option

Different requirements shall apply to Wide Area BS and Local Area BS. Using the UL reference measurement channel (12,2 kbit/s) defined in TS 125 105 [2], annex A the BER of this wanted signal shall not exceed 0,001 in the presence of interfering signals. This static reference performance shall be met when the following signals are coupled to the BS antenna input:

- a wanted signal at the assigned channel frequency, with mean power 6 dB above the static reference level (see note);
- two interfering signals with the parameters specified in table 4.2.9.2.1-1.

NOTE: The static reference level is -109 dBm for the Wide Area Base Station and -95 dBm for the Local Area Base Station.

**Table 4.2.9.2.1-1: Parameters of the interfering signals for intermodulation characteristics testing (3,84 Mcps TDD option)**

Interfering Signal mean power		Offset	Type of Interfering Signal
Wide Area BS	Local Area BS		
-48 dBm	-38 dBm	10 MHz	CW signal
-48 dBm	-38 dBm	20 MHz	WCDMA signal with one code

#### 4.2.9.2.2 1,28 Mcps TDD option

Different requirements shall apply to Wide Area BS and Local Area BS. Using the UL reference measurement channel (12,2 kbit/s) defined in TS 125 105 [2], annex A the BER of this wanted signal shall not exceed 0,001 in the presence of interfering signals. This static reference performance shall be met when the following signals are coupled to the BS antenna input:

- a wanted signal at the assigned channel frequency, with mean power 6 dB above the static reference level (see note);

- two interfering signals with the parameters specified in table 4.2.9.2.2-1.

NOTE: The static reference level is -110 dBm for the Wide Area Base Station and -96 dBm for the Local Area Base Station.

**Table 4.2.9.2.2-1: Parameters of the interfering signals for intermodulation characteristics testing (1,28 Mcps TDD option)**

Interfering Signal mean power		Offset	Type of Interfering Signal
Wide Area BS	Local Area BS		
-48 dBm	-38 dBm	3,2 MHz	CW signal
-48 dBm	-38 dBm	6,4 MHz	1,28 Mcps TDD option signal with one code

#### 4.2.9.2.3 7,68 Mcps TDD option

Different requirements shall apply to Wide Area BS and Local Area BS. Using the UL reference measurement channel (12,2 kbit/s) defined in TS 125 105 [2], annex A the BER of this wanted signal shall not exceed 0,001 in the presence of interfering signals. This static reference performance shall be met when the following signals are coupled to the BS antenna input:

- a wanted signal at the assigned channel frequency, with mean power 6 dB above the static reference level (see note);
- two interfering signals with the parameters specified in table 4.2.9.2.3-1.

NOTE: The static reference level is -109 dBm for the Wide Area Base Station and -95 dBm for the Local Area Base Station.

**Table 4.2.9.2.3-1: Parameters of the interfering signals for intermodulation characteristics testing (7,68 Mcps TDD option)**

Interfering Signal mean power		Offset	Type of Interfering Signal
Wide Area BS	Local Area BS		
-48 dBm	-38 dBm	20 MHz	CW signal
-48 dBm	-38 dBm	40 MHz	WCDMA signal with one code

#### 4.2.9.3 Conformance

Conformance tests described in clause 5.3.8 shall be carried out.

### 4.2.10 Receiver adjacent channel selectivity

#### 4.2.10.1 Definition

Adjacent channel selectivity (ACS) is a measure of the receiver ability to receive a wanted signal at its assigned channel frequency in the presence of a single code CDMA modulated adjacent channel signal at a given frequency offset from the centre frequency of the assigned channel. ACS is the ratio of the receiver filter attenuation on the assigned channel frequency to the receive filter attenuation on the adjacent channel(s).

#### 4.2.10.2 Limits

##### 4.2.10.2.1 3,84 Mcps TDD option

Different requirements shall apply to Wide Area BS and Local Area BS. The BER, measured on the wanted signal in the presence of an interfering signal, shall not exceed 0,001 for the parameters specified in table 4.2.10.2.1-1 for the Wide Area BS and table 4.2.10.2.1-2 for the Local Area BS respectively.

**Table 4.2.10.2.1-1: Parameters of the wanted signal and the interfering signal for ACS testing for Wide Area BS (3,84 Mcps TDD option)**

Parameter	Level	Unit
Reference measurement channel data rate	12,2	kbit/s
Wanted signal mean power	-103	dBm
Interfering signal mean power	-52	dBm
$F_{uw}$ (modulated)	5	MHz
NOTE: $F_{uw}$ is the frequency offset of the unwanted interfering signal from the assigned channel frequency of the wanted signal.		

**Table 4.2.10.2.1-2: Parameters of the wanted signal and the interfering signal for ACS testing for Local Area BS (3,84 Mcps TDD option)**

Parameter	Level	Unit
Reference measurement channel data rate	12,2	kbit/s
Wanted signal mean power	-89	dBm
Interfering signal mean power	-38	dBm
$F_{uw}$ (modulated)	5	MHz
NOTE: $F_{uw}$ is the frequency offset of the unwanted interfering signal from the assigned channel frequency of the wanted signal.		

#### 4.2.10.2.2 1,28 Mcps TDD option

Different requirements shall apply to Wide Area BS and Local Area BS. The BER, measured on the wanted signal in the presence of an interfering signal, shall not exceed 0,001 for the parameters specified in table 4.2.10.2.2-1 for the Wide Area BS and table 4.2.10.2.2-2 for the Local Area BS respectively.

**Table 4.2.10.2.2-1: Parameters of the wanted signal and the interfering signal for ACS testing for Wide Area BS (1,28 Mcps TDD option)**

Parameter	Level	Unit
Reference measurement channel data rate	12,2	kbit/s
Wanted signal mean power	-104	dBm
Interfering signal mean power	-55	dBm
$F_{uw}$ (modulated)	1,6	MHz
NOTE: $F_{uw}$ is the frequency offset of the unwanted interfering signal from the assigned channel frequency of the wanted signal.		

**Table 4.2.10.2.2-2: Parameters of the wanted signal and the interfering signal for ACS testing for Local Area BS (1,28 Mcps TDD option)**

Parameter	Level	Unit
Reference measurement channel data rate	12,2	kbit/s
Wanted signal mean power	-90	dBm
Interfering signal mean power	-41	dBm
$F_{uw}$ (modulated)	1,6	MHz
NOTE: $F_{uw}$ is the frequency offset of the unwanted interfering signal from the assigned channel frequency of the wanted signal.		

#### 4.2.10.2.3 7,68 Mcps TDD option

Different requirements shall apply to Wide Area BS and Local Area BS. The BER, measured on the wanted signal in the presence of an interfering signal, shall not exceed 0,001 for the parameters specified in table 4.2.10.2.3-1 for the Wide Area BS and table 4.2.10.2.3-2 for the Local Area BS respectively.



**Table 4.2.10.2.3-1: Parameters of the wanted signal and the interfering signal for ACS testing for Wide Area BS (7,68 Mcps TDD option)**

Parameter	Level	Unit
Reference measurement channel data rate	12,2	kbit/s
Wanted signal mean power	-103	dBm
Interfering signal mean power	-49	dBm
$F_{uw}$ (modulated)	10	MHz
NOTE: $F_{uw}$ is the frequency offset of the unwanted interfering signal from the assigned channel frequency of the wanted signal.		

**Table 4.2.10.2.3-2: Parameters of the wanted signal and the interfering signal for ACS testing for Local Area BS (7,68 Mcps TDD option)**

Parameter	Level	Unit
Reference measurement channel data rate	12,2	kbit/s
Wanted signal mean power	-89	dBm
Interfering signal mean power	-35	dBm
$F_{uw}$ (modulated)	10	MHz
NOTE: $F_{uw}$ is the frequency offset of the unwanted interfering signal from the assigned channel frequency of the wanted signal.		

### 4.2.10.3 Conformance

Conformance tests described in clause 5.3.9 shall be carried out.

---

## 5 Testing for compliance with technical requirements

### 5.1 Environmental conditions for testing

Tests defined in the present document shall be carried out at representative points within the boundary limits of the required operational environmental profile.

Where technical performance varies subject to environmental conditions, tests shall be carried out under a sufficient variety of environmental conditions (within the boundary limits of the required operational environmental profile) to give confidence of compliance for the affected technical requirements.

Normally it should be sufficient for all tests to be conducted using normal test conditions except where otherwise stated. For guidance on the use of other test conditions to be used in order to show compliance reference can be made to TS 125 142 [3], clause 5.9.

Many tests in the present document are performed with appropriate frequencies in the bottom, middle and top of the operating frequency band of the BS. These are denoted as RF channels B (bottom), M (middle) and T (top) as defined in TS 125 142 [3], clause 5.3.

### 5.2 Interpretation of the measurement results

The interpretation of the results recorded in a test report for the measurements described in the present document shall be as follows:

- the measured value related to the corresponding limit will be used to decide whether an equipment meets the requirements of the present document;
- the value of the measurement uncertainty for the measurement of each parameter shall be included in the test report;

- the recorded value of the measurement uncertainty shall be, for each measurement, equal to or lower than the figures in table 5.2-1.

For the test methods, according to the present document, the measurement uncertainty figures shall be calculated in accordance with TR 100 028 [i.4] and shall correspond to an expansion factor (coverage factor)  $k = 1,96$  (which provide a confidence level of 95 % in the case where the distributions characterizing the actual measurement uncertainties are normal (Gaussian)).

Table 5.2-1 is based on this expansion factor.

**Table 5.2-1: Maximum measurement uncertainty of the test system**

Parameter	Conditions	Uncertainty
5.3.1 Spectrum emission mask	-	±1,5 dB
5.3.2 Transmitter adjacent channel leakage power ratio (ACLR)	General requirement	±0,8 dB
	Requirement for protection of FDD on adjacent channels: <ul style="list-style-type: none"> <li>▪ Wide Area BS</li> <li>▪ Local Area BS</li> </ul>	±4 dB ±0,8 dB
	Requirement for protection of unsynchronized TDD on adjacent channels (for 3,84 Mcps TDD option BS): <ul style="list-style-type: none"> <li>▪ Wide Area BS</li> <li>▪ Local Area BS</li> </ul>	±4 dB ±0,8 dB
	Requirement for protection of unsynchronized TDD on adjacent channels (for 1,28 Mcps TDD option BS): <ul style="list-style-type: none"> <li>▪ Wide Area BS</li> <li>▪ Local Area BS</li> </ul>	±1 dB ±0,8 dB
5.3.3 Transmitter spurious emissions	For BS and coexistence bands	±2,0 dB
	Outside above: <ul style="list-style-type: none"> <li>▪ <math>f \leq 2,2</math> GHz</li> <li>▪ <math>2,2</math> GHz &lt; <math>f \leq 4</math> GHz</li> <li>▪ <math>4</math> GHz &lt; <math>f</math></li> </ul>	±1,5 dB ±2,0 dB ±4,0 dB
5.3.4 Base station maximum output power	-	±0,7 dB
5.3.5 Transmit intermodulation	For spectrum emission mask	±2,5 dB
	For ACLR	±2,2 dB
	For spurious emissions: for BS and coexistence bands	±2,8 dB
	Outside above: <ul style="list-style-type: none"> <li>▪ <math>f \leq 2,2</math> GHz</li> <li>▪ <math>2,2</math> GHz &lt; <math>f \leq 4</math> GHz</li> <li>▪ <math>4</math> GHz &lt; <math>f</math></li> </ul>	±2,5 dB ±2,8 dB ±4,5 dB ±1,0 dB
	Interference signal adjustment	
5.3.6 Receiver spurious emissions	For BS receive band	±3,0 dB
	Outside BS receive band: <ul style="list-style-type: none"> <li>▪ <math>f \leq 2,2</math> GHz</li> <li>▪ <math>2,2</math> GHz &lt; <math>f \leq 4</math> GHz</li> <li>▪ <math>4</math> GHz &lt; <math>f</math></li> </ul>	±2,0 dB ±2,0 dB ±4,0 dB
	Figures apply to the measurement of the EUT and not to any stimulus signals.	
5.3.7 Receiver blocking characteristics (3,84 Mcps TDD option)	offset < 15 MHz	±1,4 dB
	offset ≥ 15 MHz: <ul style="list-style-type: none"> <li>▪ <math>f \leq 2,2</math> GHz</li> <li>▪ <math>2,2</math> GHz &lt; <math>f \leq 4</math> GHz</li> <li>▪ <math>4</math> GHz &lt; <math>f</math></li> </ul>	±1,1 dB ±1,8 dB ±3,2 dB
	offset = absolute difference of centre frequency of the wanted and centre frequency of the interfering signal	

Parameter	Conditions	Uncertainty
5.3.7 Receiver blocking characteristics (1,28 Mcps TDD option)	offset < 4,8 MHz	±1,4 dB
	offset ≥ 4,8 MHz: <ul style="list-style-type: none"> <li>▪ f ≤ 2,2 GHz</li> <li>▪ 2,2 GHz &lt; f ≤ 4 GHz</li> <li>▪ 4 GHz &lt; f</li> </ul>	±1,1 dB ±1,8 dB ±3,2 dB
	offset = absolute difference of centre frequency of the wanted and centre frequency of the interfering signal	
5.3.8 Receiver intermodulation characteristics	-	±1,3 dB
5.3.9 Receiver adjacent channel selectivity (ACS)	-	±1,1 dB
NOTE 1: For RF tests it should be noted that the uncertainties in table 5.2-1 apply to the Test System operating into a nominal 50 Ω load and do not include system effects due to mismatch between the EUT and the Test System.		
NOTE 2: If the Test System for a test is known to have a measurement uncertainty greater than that specified in table 5.2-1, this equipment can still be used provided that an adjustment is made as follows: any additional uncertainty in the Test System over and above that specified in table 5.2-1 is used to tighten the Test Requirements - making the test harder to pass (for some tests, e.g. receiver tests, this may require modification of stimulus signals). This procedure will ensure that a Test System not compliant with table 5.2-1 does not increase the probability of passing a EUT that would otherwise have failed a test if a Test System compliant with table 5.2-1 had been used.		

## 5.3 Essential radio test suites

This clause describes the test suites for UTRA TDD. E-UTRA TDD Base Station test suites are given in EN 301 908-14 [6].

### 5.3.1 Spectrum emission mask

#### 5.3.1.1 Method of test

##### 5.3.1.1.1 Initial conditions

For 3,84 Mcps TDD option BS supporting 16QAM, the spectrum emission mask requirements shall be tested with the general test set up specified in clause 5.3.1.1.1.2 and also with the special test set up for 16QAM-capable BS specified in clause 5.3.1.1.1.5.

For 1,28 Mcps TDD option BS supporting 16QAM, the spectrum emission mask requirements shall be tested with the general test set up specified in clause 5.3.1.1.1.3 and also with the special test set up for 16QAM-capable BS specified in clause 5.3.1.1.1.4.

For 7,68 Mcps TDD option BS supporting 16QAM, the spectrum emission mask requirements shall be tested with the general test set up specified in clause 5.3.1.1.1.6 and also with the special test set up for 16QAM-capable BS specified in clause 5.3.1.1.1.7.

##### 5.3.1.1.1.1 General initial conditions

Test environment: normal; see TS 125 142 [3], clause 5.9.

RF channels to be tested: B, M and T; see clause 5.1.

##### 5.3.1.1.1.2 3,84 Mcps TDD option general test set up

- 1) Connect the measuring equipment to the antenna connector of the BS under test.
- 2) Set the parameters of the BS transmitted signal according to table 5.3.1.1.1.2-1.

**Table 5.3.1.1.1.2-1: Parameters of the BS transmitted signal for spectrum emission mask testing (3,84 Mcps TDD option)**

Parameter	Value/description
TDD Duty Cycle	TS i; i = 0, 1, 2, ..., 14: transmit: if i is even; receive: if i is odd.
Time slot carrying SCH	TS0
Time slots under test	TS i, i even and non zero
BS output power setting	PRAT
Number of DPCH in each time slot under test	9
Power of each DPCH	1/9 of Base Station output power
Data content of DPCH	real life (sufficient irregular)

## 5.3.1.1.1.3 1,28 Mcps TDD option general test set up

- 1) Connect the measuring equipment to the antenna connector of the BS under test.
- 2) Set the parameters of the BS transmitted signal according to table 5.3.1.1.1.3-1.

**Table 5.3.1.1.1.3-1: Parameters of the BS transmitted signal for spectrum emission mask testing (1,28 Mcps TDD option)**

Parameter	Value/description
TDD Duty Cycle	TS i; i = 0, 1, 2, 3, 4, 5, 6: transmit: if i is 0, 4, 5, 6; receive: if i is 1, 2, 3.
Time slots under test	TS 4, TS 5 and TS 6
BS output power setting	PRAT
Number of DPCH in each time slot under test	8
Power of each DPCH	1/8 of Base Station output power
Data content of DPCH	real life (sufficient irregular)

## 5.3.1.1.1.4 1,28 Mcps TDD option special test set up for 16QAM-capable BS

This test set up only applies for 16QAM-capable BS.

- 1) Connect the measuring equipment to the antenna connector of the BS under test.
- 2) Set the parameters of the BS transmitted signal according to table 5.3.1.1.1.4-1.

**Table 5.3.1.1.1.4-1: Parameters of the BS transmitted signal for spectrum emission mask testing (1,28 Mcps TDD option 16QAM-capable BS)**

Parameter	Value/description
TDD Duty Cycle	TS i; i = 0, 1, 2, 3, 4, 5, 6: transmit, if i is 0, 4, 5, 6; receive, if i is 1, 2, 3.
Time slots under test	TS 4, TS 5 and TS 6
BS output power setting	PRAT
HS-PDSCH modulation	16QAM
Number of HS-PDSCH in each time slot under test	8
Power of each HS-PDSCH	1/8 of Base Station output power
Data content of HS-PDSCH	real life (sufficient irregular)
Spreading factor	16

### 5.3.1.1.1.5 3,84 Mcps TDD option special test set up for 16QAM-capable BS

This test set up only applies for 16QAM-capable BS.

- 1) Connect the measuring equipment to the antenna connector of the BS under test.
- 2) Set the parameters of the BS transmitted signal according to table 5.3.1.1.1.5-1.

**Table 5.3.1.1.1.5-1: Parameters of the BS transmitted signal for spectrum emission mask testing (3,84 Mcps TDD option 16QAM-capable BS)**

Parameter	Value/description
TDD Duty Cycle	TS $i$ ; $i = 0, 1, 2, \dots, 14$ : transmit, if $i$ is even; receive, if $i$ is odd.
Time slot carrying SCH	TS0
Time slots under test	TS $i$ , $i$ even and non zero
BS output power setting	PRAT
HS-PDSCH modulation	16QAM
Number of HS-PDSCH in each time slot under test	9
Power of each HS-PDSCH	1/9 of Base Station output power
Data content of HS-PDSCH	real life (sufficient irregular)
Spreading factor	16

### 5.3.1.1.1.6 7,68 Mcps TDD option general test set up

- 1) Connect the measuring equipment to the antenna connector of the BS under test.
- 2) Set the parameters of the BS transmitted signal according to table 5.3.1.1.1.6-1.

**Table 5.3.1.1.1.6-1: Parameters of the BS transmitted signal for spectrum emission mask testing (7,68 Mcps TDD option)**

Parameter	Value/description
TDD Duty Cycle	TS $i$ ; $i = 0, 1, 2, \dots, 14$ : transmit: if $i$ is even; receive: if $i$ is odd.
Time slot carrying SCH	TS0
Time slots under test	TS $i$ , $i$ even and non zero
BS output power setting	PRAT
Number of DPCH in each time slot under test	9
Power of each DPCH	1/9 of Base Station output power
Data content of DPCH	real life (sufficient irregular)

### 5.3.1.1.1.7 7,68 Mcps TDD option special test set up for 16QAM-capable BS

This test set up only applies for 16QAM-capable BS.

- 1) Connect the measuring equipment to the antenna connector of the BS under test.
- 2) Set the parameters of the BS transmitted signal according to table 5.3.1.1.1.7-1.

**Table 5.3.1.1.7-1: Parameters of the BS transmitted signal for spectrum emission mask testing (7,68 Mcps TDD option 16QAM-capable BS)**

Parameter	Value/description
TDD Duty Cycle	TS $i$ ; $i = 0, 1, 2, \dots, 14$ : transmit, if $i$ is even; receive, if $i$ is odd.
Time slot carrying SCH	TS0
Time slots under test	TS $i$ , $i$ even and non zero
BS output power setting	PRAT
HS-PDSCH modulation	16QAM
Number of HS-PDSCH in each time slot under test	9
Power of each HS-PDSCH	1/9 of Base Station output power
Data content of HS-PDSCH	real life (sufficient irregular)
Spreading factor	16

### 5.3.1.1.2 Procedure

#### 5.3.1.1.2.1 3,84 Mcps TDD option

Measure the power of the BS spectrum emissions by applying measurement filters with bandwidths as specified in the relevant table in clause 4.2.2.2.1. The characteristic of the filters shall be approximately Gaussian (typical spectrum analyser filters). The centre frequency of the filter shall be stepped in contiguous steps over the ranges of frequency offsets  $f_{\text{offset}}$  as given in the tables. The step width shall be equal to the respective measurement bandwidth. The time duration of each step shall be sufficiently long to capture one active time slot.

For frequency offsets of the measurement filter centre frequency in the range  $4,0 \text{ MHz} \leq f_{\text{offset}} < f_{\text{offset}_{\text{max}}}$ , the measurement shall be performed by applying filters with measurement bandwidth of 50 kHz or less and integrating the measured results over the nominal measurement bandwidth 1 MHz.

#### 5.3.1.1.2.2 1,28 Mcps TDD option

Measure the power of the BS spectrum emissions by applying measurement filters with bandwidths as specified in the relevant table in clause 4.2.2.2.2. The characteristic of the filters shall be approximately Gaussian (typical spectrum analyser filters). The centre frequency of the filter shall be stepped in contiguous steps over the ranges of frequency offsets  $f_{\text{offset}}$  as given in the tables. The step width shall be equal to the respective measurement bandwidth. The time duration of each step shall be sufficiently long to capture one active time slot.

For frequency offsets of the measurement filter centre frequency in the range  $2,3 \text{ MHz} \leq f_{\text{offset}} < f_{\text{offset}_{\text{max}}}$ , the measurement shall be performed by applying filters with measurement bandwidth of 50 kHz or less and integrating the measured results over the nominal measurement bandwidth 1 MHz.

#### 5.3.1.1.2.3 7,68 Mcps TDD option

Measure the power of the BS spectrum emissions by applying measurement filters with bandwidths as specified in the relevant table in clause 4.2.2.2.3. The characteristic of the filters shall be approximately Gaussian (typical spectrum analyser filters). The centre frequency of the filter shall be stepped in contiguous steps over the ranges of frequency offsets  $f_{\text{offset}}$  as given in the tables. The step width shall be equal to the respective measurement bandwidth. The time duration of each step shall be sufficiently long to capture one active time slot.

For frequency offsets of the measurement filter centre frequency in the range  $6,5 \text{ MHz} \leq f_{\text{offset}} < f_{\text{offset}_{\text{max}}}$ , the measurement shall be performed by applying filters with measurement bandwidth of 50 kHz or less and integrating the measured results over the nominal measurement bandwidth 1 MHz.

### 5.3.1.2 Test requirements

#### 5.3.1.2.1 3,84 Mcps TDD option

The spectrum emissions measured according to clause 5.3.1.1.2.1 shall not exceed the maximum level specified in tables 4.2.2.2.1-1 to 4.2.2.2.1-4 for the appropriate BS rated output power table of clause 4.2.2.2.1.

### 5.3.1.2.2 1,28 Mcps TDD option

The spectrum emissions measured according to clause 5.3.1.1.2.2 shall not exceed the maximum level specified in tables 4.2.2.2.2-1 to 4.2.2.2.2-3 for the appropriate BS rated output power table of clause 4.2.2.2.2.

### 5.3.1.2.3 7,68 Mcps TDD option

The spectrum emissions measured according to clause 5.3.1.1.2.3 shall not exceed the maximum level specified in tables 4.2.2.2.3-1 to 4.2.2.2.3-4 for the appropriate BS rated output power table of clause 4.2.2.2.3.

## 5.3.2 Transmitter adjacent channel leakage power ratio

### 5.3.2.1 Method of test

#### 5.3.2.1.1 Initial conditions

For 3,84 Mcps TDD option BS supporting 16QAM, the transmitter adjacent channel leakage power ratio requirements shall be tested with the general test set up specified in clause 5.3.2.1.1.2 also with the special test set up for 16QAM-capable BS specified in clause 5.3.2.1.1.5.

For 1,28 Mcps TDD option BS supporting 16QAM, the transmitter adjacent channel leakage power ratio requirements shall be tested with the general test set up specified in clause 5.3.2.1.1.3 also with the special test set up for 16QAM-capable BS specified in clause 5.3.2.1.1.4.

For 7,68 Mcps TDD option BS supporting 16QAM, the transmitter adjacent channel leakage power ratio requirements shall be tested with the general test set up specified in clause 5.3.2.1.1.6 also with the special test set up for 16QAM-capable BS specified in clause 5.3.2.1.1.7.

#### 5.3.2.1.1.1 General initial conditions

Test environment: normal; see TS 125 142 [3], clause 5.9.

RF channels to be tested: B, M and T with multiple carriers if supported; see clause 5.1.

#### 5.3.2.1.1.2 3,84 Mcps TDD option general test set up

- 1) Connect the measuring equipment to the antenna connector of the BS under test.
- 2) Set the parameters of the BS transmitted signal according to table 5.3.2.1.1.2-1.

**Table 5.3.2.1.1.2-1: Parameters of the BS transmitted signal for ACLR testing (3,84 Mcps TDD option)**

Parameter	Value/description
TDD Duty Cycle	TS $i$ ; $i = 0, 1, 2, \dots, 14$ : transmit: if $i$ is even; receive: if $i$ is odd.
Time slot carrying SCH	TS0
Time slots under test	TS $l$ , $l$ even and non zero
BS output power setting	PRAT
Number of DPCH in each time slot under test	9
Power of each DPCH	1/9 of Base Station output power
Data content of DPCH	Real life (sufficient irregular)

#### 5.3.2.1.1.3 1,28 Mcps TDD option general test set up

- 1) Connect the measuring equipment to the antenna connector of the BS under test.
- 2) Set the parameters of the BS transmitted signal according to table 5.3.2.1.1.3-1.

**Table 5.3.2.1.1.3-1: Parameters of the BS transmitted signal for ACLR testing (1,28 Mcps TDD option)**

Parameter	Value/description
TDD Duty Cycle	TS $i$ ; $i = 0, 1, 2, 3, 4, 5, 6$ : transmit, if $i$ is 0, 4, 5, 6 receive, if $i$ is 1, 2, 3.
Time slots under test	TS 4, TS 5 and TS 6
BS output power setting	PRAT
Number of DPCH in each time slot under test	8
Power of each DPCH	1/8 of Base Station output power
Data content of DPCH	real life (sufficient irregular)

#### 5.3.2.1.1.4 1,28 Mcps TDD option special test set up for 16QAM-capable BS

This test set up only applies for 16QAM-capable BS.

- 1) Connect the measuring equipment to the antenna connector of the BS under test.
- 2) Set the parameters of the BS transmitted signal according to table 5.3.2.1.1.4-1.

**Table 5.3.2.1.1.4-1: Parameters of the BS transmitted signal for ACLR testing (1,28 Mcps TDD option 16QAM-capable BS)**

Parameter	Value/description
TDD Duty Cycle	TS $i$ ; $i = 0, 1, 2, 3, 4, 5, 6$ : transmit: if $i$ is 0, 4, 5, 6; receive: if $i$ is 1, 2, 3.
Time slots under test	TS4, TS 5 and TS 6
BS output power setting	PRAT
HS-PDSCH modulation	16QAM
Number of HS-PDSCH in each time slot under test	8
Power of each HS-PDSCH	1/8 of Base Station output power
Data content of HS-PDSCH	real life (sufficient irregular)
Spreading factor	16

#### 5.3.2.1.1.5 3,84 Mcps TDD option special test set up for 16QAM-capable BS

This test set up only applies for 16QAM-capable BS.

- 1) Connect the measuring equipment to the antenna connector of the BS under test.
- 2) Set the parameters of the BS transmitted signal according to table 5.3.2.1.1.5-1.

**Table 5.3.2.1.1.5-1: Parameters of the BS transmitted signal for ACLR testing (3,84 Mcps TDD option 16QAM-capable BS)**

Parameter	Value/description
TDD Duty Cycle	TS $i$ ; $i = 0, 1, 2, \dots, 14$ : transmit, if $i$ is even; receive, if $i$ is odd.
Time slot carrying SCH	TS0
Time slots under test	TS $i$ , $i$ even and non zero
BS output power setting	PRAT
HS-PDSCH modulation	16QAM
Number of HS-PDSCH in each time slot under test	9
Power of each HS-PDSCH	1/9 of Base Station output power
Data content of HS-PDSCH	real life (sufficient irregular)
Spreading factor	16



## 5.3.2.1.1.6 7,68 Mcps TDD option general test set up

- 1) Connect the measuring equipment to the antenna connector of the BS under test.
- 2) Set the parameters of the BS transmitted signal according to table 5.3.2.1.1.6-1.

**Table 5.3.2.1.1.6-1: Parameters of the BS transmitted signal for ACLR testing (7,68 Mcps TDD option)**

Parameter	Value/description
TDD Duty Cycle	TS $i$ ; $i = 0, 1, 2, \dots, 14$ : transmit: if $i$ is even; receive: if $i$ is odd.
Time slot carrying SCH	TS0
Time slots under test	TS $i$ , $i$ even and non zero
BS output power setting	PRAT
Number of DPCH in each time slot under test	9
Power of each DPCH	1/9 of Base Station output power
Data content of DPCH	Real life (sufficient irregular)

## 5.3.2.1.1.7 7,68 Mcps TDD option special test set up for 16QAM-capable BS

This test set up only applies for 16QAM-capable BS.

- 1) Connect the measuring equipment to the antenna connector of the BS under test.
- 2) Set the parameters of the BS transmitted signal according to table 5.3.2.1.1.7-1.

**Table 5.3.2.1.1.7-1: Parameters of the BS transmitted signal for ACLR testing (7,68 Mcps TDD option 16QAM-capable BS)**

Parameter	Value/description
TDD Duty Cycle	TS $i$ ; $i = 0, 1, 2, \dots, 14$ : transmit, if $i$ is even; receive, if $i$ is odd.
Time slot carrying SCH	TS0
Time slots under test	TS $i$ , $i$ even and non zero
BS output power setting	PRAT
HS-PDSCH modulation	16QAM
Number of HS-PDSCH in each time slot under test	9
Power of each HS-PDSCH	1/9 of Base Station output power
Data content of HS-PDSCH	real life (sufficient irregular)
Spreading factor	32

## 5.3.2.1.2 Procedure

## 5.3.2.1.2.1 3,84 Mcps TDD option

- 1) Measure RRC filtered mean power centred on the assigned channel frequency over the 2 464 active chips of the even time slots TS  $i$  (this excludes the guard period).
- 2) Average over the number of time slots defined in TS 125 142 [3].
- 3) Measure the RRC filtered mean power at the first lower adjacent RF channel (centre frequency 5 MHz below the assigned channel frequency of the transmitted signal) over the useful part of the burst within the even time slots TS  $i$  (this excludes the guard period).
- 4) Average over the number of time slots defined in TS 125 142 [3].
- 5) Calculate the ACLR by the ratio:
  - ACLR = average power according to step 2) / average power according to step 4).

- 6) Repeat steps 3), 4) and 5) for the second lower adjacent RF channel (centre frequency 10 MHz below the assigned channel frequency of the transmitted signal).
- 7) In case of a multi-carrier BS, repeat steps 1) and 2) for the highest assigned channel frequency. Otherwise, use the result obtained in step 2) above for further calculation in step 10).
- 8) Measure the RRC filtered mean power at the first higher adjacent RF channel (centre frequency 5 MHz above the highest assigned channel frequency of the transmitted signal) over the useful part of the burst within the even time slots TS *i* (this excludes the guard period).
- 9) Average over the number of time slots defined in TS 125 142 [3].
- 10) Calculate the ACLR by the ratio:
  - $ACLR = \text{average power according to step 7) / average power according to step 9)}$ .
- 11) Repeat steps 8) to 10) for the second higher adjacent RF channel (centre frequency 10 MHz above the highest assigned channel frequency of the transmitted signal).

#### 5.3.2.1.2.2 1,28 Mcps TDD option

- 1) Measure RRC filtered mean power centred on the assigned channel frequency over the 848 active chips of the transmit time slots TS *i* (this excludes the guard period).
- 2) Average over the number of time slots defined in TS 125 142 [3].
- 3) Measure the RRC filtered mean power at the first lower adjacent RF channel (centre frequency 1,6 MHz below the assigned channel frequency of the transmitted signal) over the useful part of the burst within the transmit time slots TS *i* (this excludes the guard period).
- 4) Average over the number of time slots defined in TS 125 142 [3].
- 5) Calculate the ACLR by the ratio:
  - $ACLR = \text{average power according to step 2) / average power according to step 4)}$ .
- 6) Repeat steps 3), 4) and 5) for the second lower adjacent RF channel (centre frequency 3,2 MHz below the assigned channel frequency of the transmitted signal).
- 7) In case of a multi-carrier BS, repeat steps 1) and 2) for the highest assigned channel frequency. Otherwise, use the result obtained in step 2) above for further calculation in step 10).
- 8) Measure the RRC filtered mean power at the first higher adjacent RF channel (centre frequency 1,6 MHz above the highest assigned channel frequency of the transmitted signal) over the useful part of the burst within the transmit time slots TS *i* (this excludes the guard period).
- 9) Average over the number of time slots defined in TS 125 142 [3].
- 10) Calculate the ACLR by the ratio:
  - $ACLR = \text{average power according to step 7) / average power according to step 9)}$ .
- 11) Repeat steps 8) to 10) for the second higher adjacent RF channel (centre frequency 3,2 MHz above the highest assigned channel frequency of the transmitted signal).

#### 5.3.2.1.2.3 7,68 Mcps TDD option

- 1) Measure RRC filtered mean power centred on the assigned channel frequency over the 4 928 active chips of the even time slots TS *i* (this excludes the guard period).
- 2) Average over the number of time slots defined in TS 125 142 [3].
- 3) Measure the RRC filtered mean power at the first lower adjacent RF channel (centre frequency 10 MHz below the assigned channel frequency of the transmitted signal) over the useful part of the burst within the even time slots TS *i* (this excludes the guard period).

- 4) Average over the number of time slots defined in TS 125 142 [3].
- 5) Calculate the ACLR by the ratio:
  - $ACLR = \text{average power according to step 2) / average power according to step 4)}$ .
- 6) Repeat steps 3), 4) and 5) for the second lower adjacent RF channel (centre frequency 20 MHz below the assigned channel frequency of the transmitted signal).
- 7) In case of a multi-carrier BS, repeat steps 1) and 2) for the highest assigned channel frequency. Otherwise, use the result obtained in step 2) above for further calculation in step 10).
- 8) Measure the RRC filtered mean power at the first higher adjacent RF channel (centre frequency 10 MHz above the highest assigned channel frequency of the transmitted signal) over the useful part of the burst within the even time slots TS  $i$  (this excludes the guard period).
- 9) Average over the number of time slots defined in TS 125 142 [3].
- 10) Calculate the ACLR by the ratio:
  - $ACLR = \text{average power according to step 7) / average power according to step 9)}$ .
- 11) Repeat steps 8) to 10) for the second higher adjacent RF channel (centre frequency 20 MHz above the highest assigned channel frequency of the transmitted signal).

### 5.3.2.2 Test requirements

#### 5.3.2.2.1 3,84 Mcps TDD option

The ACLR calculated in steps 5) and 10) of clause 5.3.2.1.2.1 shall be equal or greater than the limits given in table 4.2.3.2.1.1-1. The adjacent channel leakage power measured according to step 9) of clause 5.3.2.1.2.1 shall not exceed the maximum levels specified in table 4.2.3.2.2.1-1 for adjacent channels in the frequency ranges specified in tables 4.2.3.2.2.1-1 and 4.2.3.2.3.1-1.

#### 5.3.2.2.2 1,28 Mcps TDD option

The ACLR calculated in steps 5) and 10) of clause 5.3.2.1.2.2 shall be equal or greater than the limits given in table 4.2.3.2.1.2-1. The adjacent channel leakage power measured according to step 9) of clause 5.3.2.1.2.2 shall not exceed the maximum level specified in table 4.2.3.2.2.2-1 for the measurement frequency specified in tables 4.2.3.2.2.2-1 and 4.2.3.2.3.2-1.

#### 5.3.2.2.3 7,68 Mcps TDD option

The ACLR calculated in steps 5) and 10) of clause 5.3.2.1.2.3 shall be equal or greater than the limits given in table 4.2.3.2.1.3-1. The adjacent channel leakage power measured according to step 9) of clause 5.3.2.1.2.3 shall not exceed the maximum levels specified in table 4.2.3.2.2.3-1 for adjacent channels in the frequency ranges specified in tables 4.2.3.2.2.3-1, 4.2.3.2.3.3-1 and 4.2.3.2.3.3-2.

## 5.3.3 Transmitter spurious emissions

### 5.3.3.1 Method of test

#### 5.3.3.1.1 Initial conditions

For 3,84 Mcps TDD option BS supporting 16QAM, the transmitter spurious emission requirements shall be tested with the general test set up specified in clause 5.3.3.1.1.2 and also with the special test set up for 16QAM-capable BS specified in clause 5.3.3.1.1.5.

For 1,28 Mcps TDD option BS supporting 16QAM, the transmitter spurious emission requirements shall be tested with the general test set up specified in clause 5.3.3.1.1.3 and also with the special test set up for 16QAM-capable BS specified in clause 5.3.3.1.1.4.

For 7,68 Mcps TDD option BS supporting 16QAM, the transmitter spurious emission requirements shall be tested with the general test set up specified in clause 5.3.3.1.1.6 and also with the special test set up for 16QAM-capable BS specified in clause 5.3.3.1.1.7.

#### 5.3.3.1.1.1 General initial conditions

Test environment: normal; see TS 125 142 [3], clause 5.9.

RF channels to be tested: B, M and T with multiple carriers if supported; see clause 5.1.

#### 5.3.3.1.1.2 3,84 Mcps TDD option general test set up

- 1) Connect the measuring equipment to the antenna connector of the BS under test.
- 2) Set the parameters of the BS transmitted signal according to table 5.3.3.1.1.2-1.

**Table 5.3.3.1.1.2-1: Parameters of the BS transmitted signal for spurious emissions testing (3,84 Mcps TDD option)**

Parameter	Value/description
TDD Duty Cycle	TS $i$ ; $i = 0, 1, 2, \dots, 14$ : transmit, if $i$ is even; Receive, if $i$ is odd.
Time slot carrying SCH	TS0
Time slots under test	TS $i$ , $i$ even and non zero
BS output power setting	PRAT
Number of DPCH in each time slot under test	9
Power of each DPCH	1/9 of Base Station output power
Data content of DPCH	real life (sufficient irregular)

#### 5.3.3.1.1.3 1,28 Mcps TDD option general test set up

- 1) Connect the measuring equipment to the antenna connector of the BS under test.
- 2) Set the parameters of the BS transmitted signal according to table 5.3.3.1.1.3-1.

**Table 5.3.3.1.1.3-1: Parameters of the BS transmitted signal for spurious emission testing (1,28 Mcps TDD option)**

Parameter	Value/description
TDD Duty Cycle	TS $i$ ; $i = 0, 1, 2, 3, 4, 5, 6$ : transmit, if $i$ is 0, 4, 5, 6; Receive, if $i$ is 1, 2, 3.
Time slots under test	TS 4, TS 5 and TS 6
BS output power setting	PRAT
Number of DPCH in each time slot under test	8
Power of each DPCH	1/8 of Base Station output power
Data content of DPCH	real life (sufficient irregular)

#### 5.3.3.1.1.4 1,28 Mcps TDD option special test set up for 16QAM-capable BS

This test set up only applies for 16QAM-capable BS.

- 1) Connect the measuring equipment to the antenna connector of the BS under test.
- 2) Set the parameters of the BS transmitted signal according to table 5.3.3.1.1.4-1.

**Table 5.3.3.1.1.4-1: Parameters of the BS transmitted signal for spurious emission testing (1,28 Mcps TDD option 16QAM-capable BS)**

Parameter	Value/description
TDD Duty Cycle	TS $i$ ; $i = 0, 1, 2, 3, 4, 5, 6$ : transmit, if $i$ is 0, 4, 5, 6; Receive, if $i$ is 1, 2, 3.
Time slots under test	TS 4, TS 5 and TS 6
BS output power setting	PRAT
HS-PDSCH modulation	16QAM
Number of HS-PDSCH in each time slot under test	8
Power of each HS-PDSCH	1/8 of Base Station output power
Data content of HS-PDSCH	real life (sufficient irregular)
Spreading factor	16

#### 5.3.3.1.1.5 3,84 Mcps TDD option special test set up for 16QAM-capable BS

This test set up only applies for 16QAM-capable BS.

- 1) Connect the measuring equipment to the antenna connector of the BS under test.
- 2) Set the parameters of the BS transmitted signal according to table 5.3.3.1.1.5-1.

**Table 5.3.3.1.1.5-1: Parameters of the BS transmitted signal for spurious emission testing (3,84 Mcps TDD option 16QAM-capable BS)**

Parameter	Value/description
TDD Duty Cycle	TS $i$ ; $i = 0, 1, 2, \dots, 14$ : transmit, if $i$ is even; receive, if $i$ is odd.
Time slot carrying SCH	TS0
Time slots under test	TS $i$ , $i$ even and non zero
BS output power setting	PRAT
HS-PDSCH modulation	16QAM
Number of HS-PDSCH in each time slot under test	9
Power of each HS-PDSCH	1/9 of Base Station output power
Data content of HS-PDSCH	real life (sufficient irregular)
Spreading factor	16

#### 5.3.3.1.1.6 7,68 Mcps TDD option general test set up

- 1) Connect the measuring equipment to the antenna connector of the BS under test.
- 2) Set the parameters of the BS transmitted signal according to table 5.3.3.1.1.6-1.

**Table 5.3.3.1.1.6-1: Parameters of the BS transmitted signal for spurious emissions testing (7,68 Mcps TDD option)**

Parameter	Value/description
TDD Duty Cycle	TS $i$ ; $i = 0, 1, 2, \dots, 14$ : transmit, if $i$ is even; Receive, if $i$ is odd.
Time slot carrying SCH	TS0
Time slots under test	TS $i$ , $i$ even and non zero
BS output power setting	PRAT
Number of DPCH in each time slot under test	9
Power of each DPCH	1/9 of Base Station output power
Data content of DPCH	real life (sufficient irregular)

### 5.3.3.1.1.7 7,68 Mcps TDD option special test set up for 16QAM-capable BS

This test set up only applies for 16QAM-capable BS.

- 1) Connect the measuring equipment to the antenna connector of the BS under test.
- 2) Set the parameters of the BS transmitted signal according to table 5.3.3.1.1.7-1.

**Table 5.3.3.1.1.7-1: Parameters of the BS transmitted signal for spurious emission testing (7,68 Mcps TDD option 16QAM-capable BS)**

Parameter	Value/description
TDD Duty Cycle	TS $i$ ; $i = 0, 1, 2, \dots, 14$ : transmit, if $i$ is even; receive, if $i$ is odd.
Time slot carrying SCH	TS0
Time slots under test	TS $i$ , $i$ even and non zero
BS output power setting	PRAT
HS-PDSCH modulation	16QAM
Number of HS-PDSCH in each time slot under test	9
Power of each HS-PDSCH	1/9 of Base Station output power
Data content of HS-PDSCH	real life (sufficient irregular)
Spreading factor	32

### 5.3.3.1.2 Procedure

Measure the power of the spurious emissions by applying measurement filters with bandwidths as specified in the relevant tables of clause 4.2.4.2. The characteristics of the measurement filter with the bandwidth 1,28 MHz, 3,84 MHz or 7,68 MHz shall be RRC with roll-off  $\alpha = 0,22$ . The characteristics of the measurement filters with bandwidths 100 kHz and 1 MHz shall be approximately Gaussian (typical spectrum analyzer filter). The centre frequency of the filter shall be stepped in contiguous steps over the frequency bands as given in the tables. The step width shall be equal to the respective measurement bandwidth. The time duration of each step shall be sufficiently long to capture one active time slot.

### 5.3.3.2 Test requirements

The spurious emissions measured according to clause 5.3.3.1.2 shall not exceed the limits specified in the relevant tables of clause 4.2.4.2.

## 5.3.4 Base station maximum output power

### 5.3.4.1 Method of test

#### 5.3.4.1.1 Initial conditions

##### 5.3.4.1.1.1 General initial conditions

Test environment: normal; see TS 125 142 [3], clause 5.9.

RF channels to be tested: B, M and T; see clause 5.1.

In addition, on one UARFCN only, the test shall be performed under extreme power supply as defined in TS 125 142 [3], clause 5.9.

NOTE: Tests under extreme power supply also test extreme temperature.

## 5.3.4.1.1.2 3,84 Mcps TDD option

- 1) The transmitter under test and all other transmitters of the Base Station (if any) are switched on.
- 2) The power of the transmitters not under test (if any) is controlled down.
- 3) Connect the power measuring equipment to the BS antenna connector.
- 4) Set the parameters of the transmitted signal according to table 5.3.4.1.1.2-1.

**Table 5.3.4.1.1.2-1: Parameters of the transmitted signal for maximum output power test (3,84 Mcps TDD option)**

Parameter	Value/description
TDD Duty Cycle	TS $i$ ; $i = 0, 1, 2, \dots, 14$ : transmit, if $i$ is even; receive, if $i$ is odd.
Time slot carrying SCH	TS0
Time slots under test	TS $i$ , $i$ even and non zero
BS output power setting	PRAT
Number of DPCH in each time slot under test	9
Power of each DPCH	1/9 of Base Station output power
Data content of DPCH	real life (sufficient irregular)

## 5.3.4.1.1.3 1,28 Mcps TDD option

- 1) The transmitter under test and all other transmitters of the Base Station (if any) are switched on.
- 2) The power of the transmitters not under test (if any) is controlled down.
- 3) Connect the power measuring equipment to the BS antenna connector.
- 4) Set the parameters of the transmitted signal according to table 5.3.4.1.1.3-1.

**Table 5.3.4.1.1.3-1: Parameters of the transmitted signal for maximum output power test (1,28 Mcps TDD option)**

Parameter	Value/description
TDD Duty Cycle	TS $i$ ; $i = 0, 1, 2, 3, 4, 5, 6$ : transmit, if $i$ is 0, 4, 5, 6; Receive, if $i$ is 1, 2, 3.
Time slots under test	TS 4, TS 5 and TS 6
BS output power setting	PRAT
Number of DPCH in each time slot under test	8
Power of each DPCH	1/8 of Base Station output power
Data content of DPCH	real life (sufficient irregular)

## 5.3.4.1.1.4 7,68 Mcps TDD option

- 1) The transmitter under test and all other transmitters of the Base Station (if any) are switched on.
- 2) The power of the transmitters not under test (if any) is controlled down.
- 3) Connect the power measuring equipment to the BS antenna connector.
- 4) Set the parameters of the transmitted signal according to table 5.3.4.1.1.4-1.

**Table 5.3.4.1.1.4-1: Parameters of the transmitted signal for maximum output power test (7,68 Mcps TDD option)**

Parameter	Value/description
TDD Duty Cycle	TS $i$ ; $i = 0, 1, 2, \dots, 14$ : transmit, if $i$ is even; receive, if $i$ is odd.
Time slot carrying SCH	TS0
Time slots under test	TS $i$ , $i$ even and non zero
BS output power setting	PRAT
Number of DPCH in each time slot under test	9
Power of each DPCH	1/9 of Base Station output power
Data content of DPCH	real life (sufficient irregular)

### 5.3.4.1.2 Procedure

#### 5.3.4.1.2.1 3,84 Mcps TDD option

- 1) Measure the output power of the BS signal.
- 2) Run step 1) for RF channels B/M/T.

#### 5.3.4.1.2.2 1,28 Mcps TDD option

- 1) Measure the output power of the BS signal.
- 2) Run step 1) for RF channels B/M/T.

#### 5.3.4.1.2.3 7,68 Mcps TDD option

- 1) Measure the output power of the BS signal.
- 2) Run step 1) for RF channels B/M/T.

### 5.3.4.2 Test requirements

The value of the measured output power, derived according to clause 5.3.4.1.2, shall be within the tolerance defined in clause 4.2.5.2.

## 5.3.5 Transmit intermodulation

### 5.3.5.1 Method of test

#### 5.3.5.1.1 Initial conditions

For 3,84 Mcps TDD option BS supporting 16QAM, the transmit intermodulation requirements shall be tested with the general test set up specified in clause 5.3.5.1.1.2 and also with the special test set up for 16QAM-capable BS specified in clause 5.3.5.1.1.5.

For 1,28 Mcps TDD option BS supporting 16QAM, the transmit intermodulation requirements shall be tested with the general test set up specified in clause 5.3.5.1.1.3 and also with the special test set up for 16QAM-capable BS specified in clause 5.3.5.1.1.4.

For 7,68 Mcps TDD option BS supporting 16QAM, the transmit intermodulation requirements shall be tested with the general test set up specified in clause 5.3.5.1.1.6 and also with the special test set up for 16QAM-capable BS specified in clause 5.3.5.1.1.7.



### 5.3.5.1.1.1 General initial conditions

Test environment: normal; see TS 125 142 [3], clause 5.9.

RF channels to be tested: B, M and T; see clause 5.1.

### 5.3.5.1.1.2 3,84 Mcps TDD option general test set up

- 1) Connect the measuring equipment, the BS under test and the CDMA signal generator as shown in figure 5.3.5.1.1.2-1.

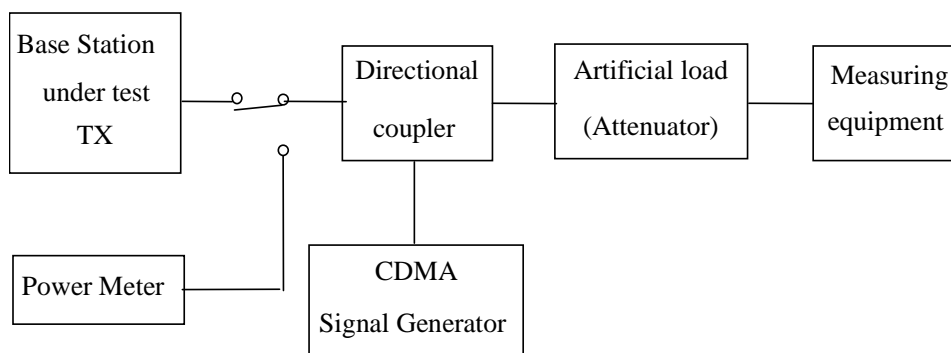

**Figure 5.3.5.1.1.2-1: Measuring setup for Base Station transmit intermodulation testing (3,84 Mcps TDD option)**

- 2) Set the parameters of the BS transmitted signal according to table 5.3.5.1.1.2-1.

**Table 5.3.5.1.1.2-1: Parameters of the BS transmitted signal for transmit intermodulation testing (3,84 Mcps TDD option)**

Parameter	Value/description
TDD Duty Cycle	TS $i$ ; $i = 0, 1, 2, \dots, 14$ : transmit, if $i$ is odd; Receive, if $i$ is even.
Time slot carrying SCH	TS0
Time slots under test	TS $i$ , $i$ even and non zero
BS output power setting	PRAT
Number of DPCH in each time slot under test	9
Power of each DPCH	1/9 of Base Station output power
Data content of DPCH	real life (sufficient irregular)

- 3) Configure the CDMA signal generator to produce an interference signal with a level of 30 dB lower than that of the BS transmitted signal. The interference signal shall be like-modulated as the BS transmitted signal, and the active time slots of both signals shall be synchronized. The frequency of the interference signal shall be  $\pm 5$  MHz,  $\pm 10$  MHz and  $\pm 15$  MHz offset from the BS transmitted signal but excluding interference frequencies outside the frequency range 1 900 MHz to 1 920 MHz, 2 010 MHz to 2 025 MHz and 2 570 MHz to 2 620 MHz respectively.

## 5.3.5.1.1.3 1,28 Mcps TDD option general test set up

- 1) Connect the measuring equipment, the BS under test and the 1,28 Mcps TDD signal generator as shown in figure 5.3.5.1.1.3-1.

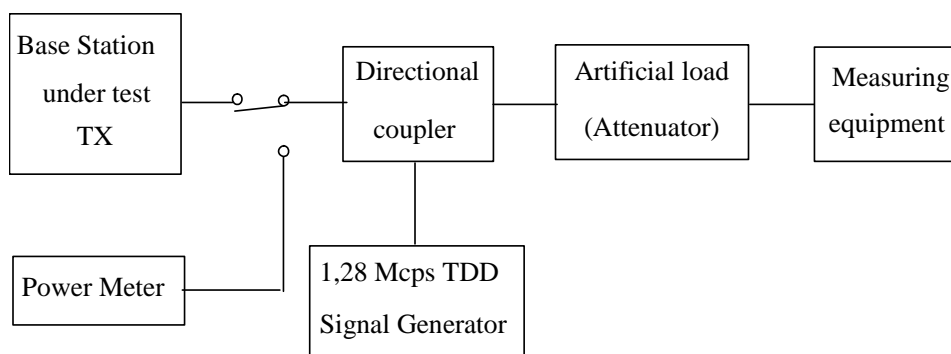

**Figure 5.3.5.1.1.3-1: Measuring setup for Base Station transmit intermodulation testing (1,28 Mcps TDD option)**

- 2) Set the parameters of the BS transmitted signal according to table 5.3.5.1.1.3-1.

**Table 5.3.5.1.1.3-1: Parameters of the BS transmitted signal for transmit intermodulation testing (1,28 Mcps TDD option)**

Parameter	Value/description
TDD Duty Cycle	TS $i$ ; $i = 0, 1, 2, 3, 4, 5, 6$ : transmit, if $i$ is 0, 4, 5, 6; receive, if $i$ is 1, 2, 3.
Time slots under test	TS 4, TS 5 and TS 6
BS output power setting	PRAT
Number of DPCH in each time slot under test	8
Power of each DPCH	1/8 of Base Station output power
Data content of DPCH	real life (sufficient irregular)

- 3) Configure the 1,28 Mcps TDD signal generator to produce an interference signal with a level of 30 dB lower than that of the BS transmitted signal. The interference signal shall be like-modulated as the BS transmitted signal, and the active time slots of both signals shall be synchronized. The frequency of the interference signal shall be  $\pm 1,6$  MHz,  $\pm 3,2$  MHz and  $\pm 4,8$  MHz offset from the BS transmitted signal but excluding interference frequencies outside the frequency range 1 900 MHz to 1 920 MHz, 2 010 MHz to 2 025 MHz and 2 570 MHz to 2 620 MHz respectively.

## 5.3.5.1.1.4 1,28 Mcps TDD option special test set up for 16QAM-capable BS

This test set up only applies for 16QAM-capable BS.

- 1) Connect the measuring equipment, the BS under test and the 1,28 Mcps TDD signal generator as shown in figure 5.3.5.1.1.4-1.

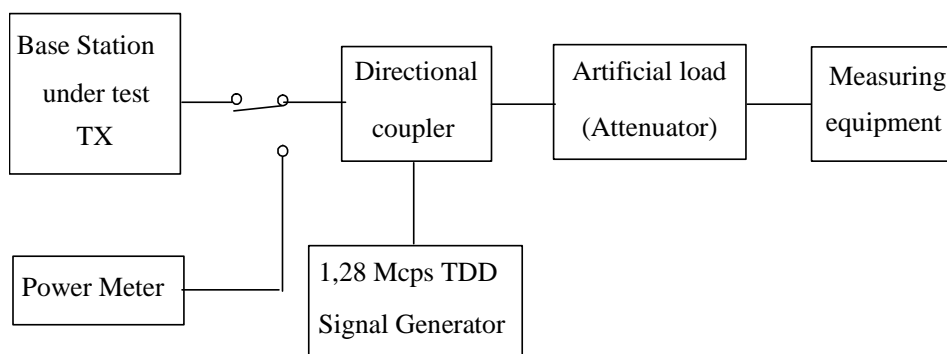

**Figure 5.3.5.1.1.4-1: Measuring setup for Base Station transmit intermodulation testing (1,28 Mcps TDD option 16QAM-capable BS)**

- 2) Set the parameters of the BS transmitted signal according to table 5.3.5.1.1.4-1.

**Table 5.3.5.1.1.4-1: Parameters of the BS transmitted signal for transmit intermodulation testing (1,28 Mcps TDD option 16QAM-capable BS)**

Parameter	Value/description
TDD Duty Cycle	TS $i$ ; $i = 0, 1, 2, 3, 4, 5, 6$ : transmit, if $i$ is 0, 4, 5, 6; receive, if $i$ is 1, 2, 3.
Time slots under test	TS 4, TS 5 and TS 6
BS output power setting	PRAT
HS-PDSCH modulation	16QAM
Number of HS-PDSCH in each time slot under test	8
Power of each HS-PDSCH	1/8 of Base Station output power
Data content of HS-PDSCH	real life (sufficient irregular)
Spreading factor	16

- 3) Configure the 1,28 Mcps TDD signal generator to produce an interference signal with a level of 30 dB lower than that of the BS transmitted signal. The interference signal shall be like-modulated as the BS transmitted signal, and the active time slots of both signals shall be synchronized. The frequency of the interference signal shall be  $\pm 1,6$  MHz,  $\pm 3,2$  MHz and  $\pm 4,8$  MHz offset from the BS transmitted signal but excluding interference frequencies outside the frequency range 1 900 MHz to 1 920 MHz, 2 010 MHz to 2 025 MHz and 2 570 MHz to 2 620 MHz respectively.

#### 5.3.5.1.1.5 3,84 Mcps TDD option special test set up for 16QAM-capable BS

This test set up only applies for 16QAM-capable BS.

- 1) Connect the measuring equipment, the BS under test and the CDMA signal generator as shown in figure 5.3.5.1.1.5-1.

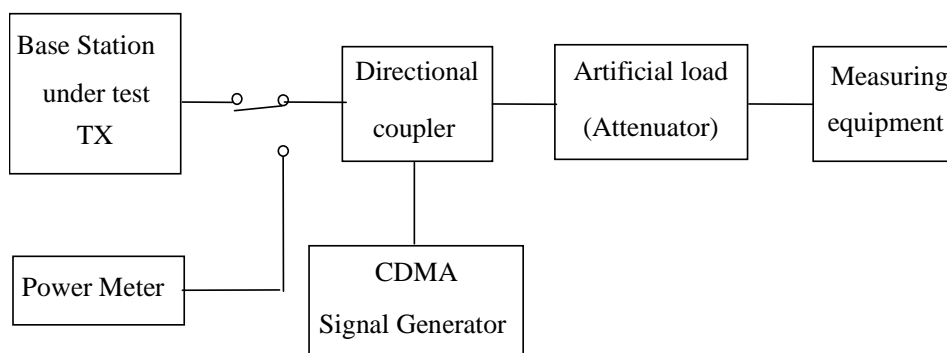

**Figure 5.3.5.1.1.5-1: Measuring setup for Base Station transmit intermodulation testing (3,84 Mcps TDD option 16QAM-capable BS)**

- 2) Set the parameters of the BS transmitted signal according to table 5.3.5.1.1.5-1.

**Table 5.3.5.1.1.5-1: Parameters of the BS transmitted signal for transmit intermodulation testing (3,84 Mcps TDD option 16QAM-capable BS)**

Parameter	Value/description
TDD Duty Cycle	TS $i$ ; $i = 0, 1, 2, \dots, 14$ : transmit, if $i$ is even; receive, if $i$ is odd.
Time slot carrying SCH	TS0
Time slots under test	TS $i$ , $i$ even and non zero
BS output power setting	PRAT
HS-PDSCH modulation	16QAM
Number of HS-PDSCH in each time slot under test	9
Power of each HS-PDSCH	1/9 of Base Station output power
Data content of HS-PDSCH	real life (sufficient irregular)
Spreading factor	16

- 3) Configure the CDMA signal generator to produce an interference signal with a level of 30 dB lower than that of the BS transmitted signal. The interference signal shall be like-modulated as the BS transmitted signal, and the active time slots of both signals shall be synchronized. The frequency of the interference signal shall be  $\pm 5$  MHz,  $\pm 10$  MHz and  $\pm 15$  MHz offset from the BS transmitted signal but excluding interference frequencies outside the frequency range 1 900 MHz to 1 920 MHz, 2 010 MHz to 2 025 MHz and 2 570 MHz to 2 620 MHz respectively.

#### 5.3.5.1.1.6 7,68 Mcps TDD option general test set up

- 1) Connect the measuring equipment, the BS under test and the CDMA signal generator as shown in figure 5.3.5.1.1.6-1.

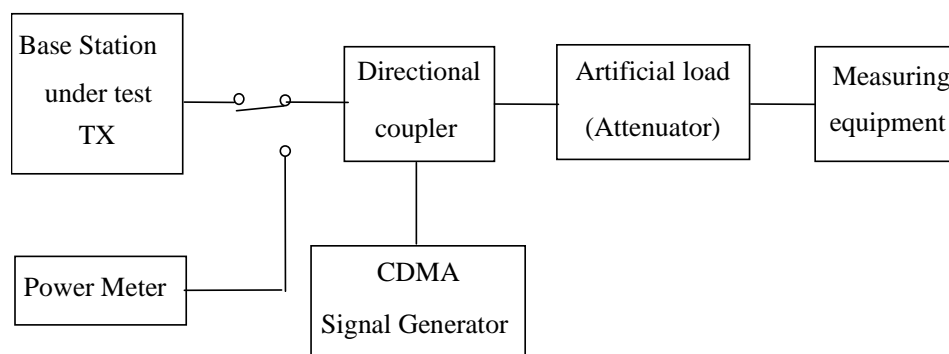

**Figure 5.3.5.1.1.6-1: Measuring setup for Base Station transmit intermodulation testing (7,68 Mcps TDD option)**

- 2) Set the parameters of the BS transmitted signal according to table 5.3.5.1.1.6-1.

**Table 5.3.5.1.1.6-1: Parameters of the BS transmitted signal for transmit intermodulation testing (7,68 Mcps TDD option)**

Parameter	Value/description
TDD Duty Cycle	TS $i$ ; $i = 0, 1, 2, \dots, 14$ : transmit, if $i$ is odd; Receive, if $i$ is even.
Time slot carrying SCH	TS0
Time slots under test	TS $i$ , $i$ even and non zero
BS output power setting	PRAT
Number of DPCH in each time slot under test	9
Power of each DPCH	1/9 of Base Station output power
Data content of DPCH	real life (sufficient irregular)

- 3) Configure the CDMA signal generator to produce an interference signal with a level of 30 dB lower than that of the BS transmitted signal. The interference signal shall be like-modulated as the BS transmitted signal, and the active time slots of both signals shall be synchronized. The frequency of the interference signal shall be  $\pm 10$  MHz,  $\pm 20$  MHz and  $\pm 30$  MHz offset from the BS transmitted signal but excluding interference frequencies outside the frequency range 1 900 MHz to 1 920 MHz, 2 010 MHz to 2 025 MHz and 2 570 MHz to 2 620 MHz respectively.

#### 5.3.5.1.1.7 7,68 Mcps TDD option special test set up for 16QAM-capable BS

This test set up only applies for 16QAM-capable BS.

- 1) Connect the measuring equipment, the BS under test and the CDMA signal generator as shown in figure 5.3.5.1.1.7-1.

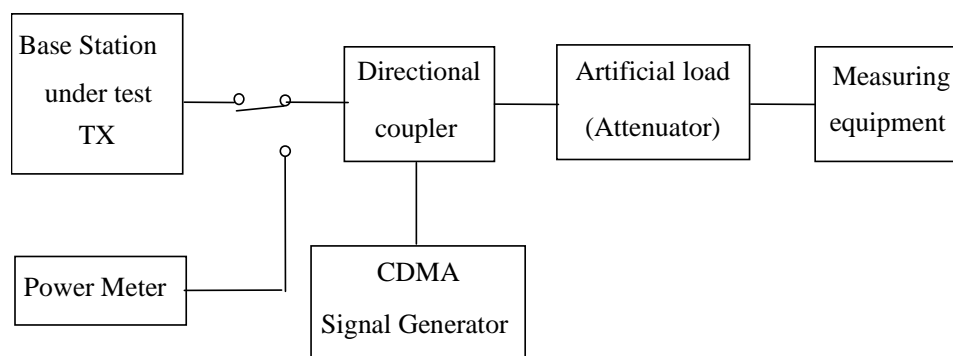

**Figure 5.3.5.1.1.7-1: Measuring setup for Base Station transmit intermodulation testing (7,68 Mcps TDD option 16QAM-capable BS)**

- 2) Set the parameters of the BS transmitted signal according to table 5.3.5.1.1.7-1.

**Table 5.3.5.1.1.7-1: Parameters of the BS transmitted signal for transmit intermodulation testing (7,68 Mcps TDD option 16QAM-capable BS)**

Parameter	Value/description
TDD Duty Cycle	TS $i$ ; $i = 0, 1, 2, \dots, 14$ : transmit, if $i$ is even; receive, if $i$ is odd.
Time slot carrying SCH	TS0
Time slots under test	TS $i$ , $i$ even and non zero
BS output power setting	PRAT
HS-PDSCH modulation	16QAM
Number of HS-PDSCH in each time slot under test	9
Power of each HS-PDSCH	1/9 of Base Station output power
Data content of HS-PDSCH	real life (sufficient irregular)
Spreading factor	32

- 3) Configure the CDMA signal generator to produce an interference signal with a level of 30 dB lower than that of the BS transmitted signal. The interference signal shall be like-modulated as the BS transmitted signal, and the active time slots of both signals shall be synchronized. The frequency of the interference signal shall be  $\pm 10$  MHz,  $\pm 20$  MHz and  $\pm 30$  MHz offset from the BS transmitted signal but excluding interference frequencies outside the frequency range 1 900 MHz to 1 920 MHz, 2 010 MHz to 2 025 MHz and 2 570 MHz to 2 620 MHz respectively.

#### 5.3.5.1.2 Procedure

Apply the test procedures for out of band described in clauses 5.3.1.1 and 5.3.2.1 and for transmitter spurious emissions as described in clause 5.3.3.1 at the frequencies of all third and fifth order intermodulation products. The frequency band occupied by the interference signal is excluded from the measurements.

### 5.3.5.2 Test requirements

The conformance requirements for out of band as specified in clauses 4.2.2.2 and 4.2.3.2 and for transmitter spurious emissions as specified in clause 4.2.4.2 shall be met at the frequencies of all third and fifth order intermodulation products.

## 5.3.6 Receiver spurious emissions

### 5.3.6.1 Method of test

#### 5.3.6.1.1 Initial conditions

##### 5.3.6.1.1.1 General initial conditions

Test environment: normal; see TS 125 142 [3], clause 5.9.

RF channels to be tested: M; see clause 5.1.

##### 5.3.6.1.1.2 3,84 Mcps TDD option

- 1) Connect the measuring equipment to the antenna connector of one BS Rx port.
- 2) Terminate or disable any other BS Rx port not under test.
- 3) Set the BS receiver to operational mode.
- 4) Set the BS to transmit a signal with parameters according to table 5.3.6.1.1.2-1.
- 5) Terminate the Tx port(s).

**Table 5.3.6.1.1.2-1: Parameters of the transmitted signal for receiver spurious emissions test (3,84 Mcps TDD option)**

Parameter	Value/description
TDD Duty Cycle	TS $i$ ; $i = 0, 1, 2, \dots, 14$ : transmit, if $i$ is even; receive, if $i$ is odd.
Time slot carrying SCH	TS0
Time slots under test	TS $i$ , $i$ even and non zero
BS output power setting	PRAT
Number of DPCH in each time slot under test	9
Power of each DPCH	1/9 of Base Station output power
Data content of DPCH	real life (sufficient irregular)

##### 5.3.6.1.1.3 1,28 Mcps TDD option

- 1) Connect the measuring equipment to the antenna connector of one BS Rx port.
- 2) Terminate or disable any other BS Rx port not under test.
- 3) Set the BS receiver to operational mode.
- 4) Set the BS to transmit a signal with parameters according to table 5.3.6.1.1.3-1.
- 5) Terminate the Tx port(s).

**Table 5.3.6.1.1.3-1: Parameters of the transmitted signal for receiver spurious emissions test (1,28 Mcps TDD option)**

Parameter	Value/description
TDD Duty Cycle	TS $i$ ; $i = 0, 1, 2, 3, 4, 5, 6$ : transmit, if $i$ is 0, 4, 5, 6; receive, if $i$ is 1, 2, 3.
Time slots under test	TS 4, TS 5 and TS 6
BS output power setting	PRAT
Number of DPCH in each time slot under test	8
Power of each DPCH	1/8 of Base Station output power
Data content of DPCH	real life (sufficient irregular)

#### 5.3.6.1.1.4 7,68 Mcps TDD option

- 1) Connect the measuring equipment to the antenna connector of one BS Rx port.
- 2) Terminate or disable any other BS Rx port not under test.
- 3) Set the BS receiver to operational mode.
- 4) Set the BS to transmit a signal with parameters according to table 5.3.6.1.1.4-1.
- 5) Terminate the Tx port(s).

**Table 5.3.6.1.1.4-1: Parameters of the transmitted signal for receiver spurious emissions test (7,68 Mcps TDD option)**

Parameter	Value/description
TDD Duty Cycle	TS $i$ ; $i = 0, 1, 2, \dots, 14$ : transmit, if $i$ is even; receive, if $i$ is odd.
Time slot carrying SCH	TS0
Time slots under test	TS $i$ , $i$ even and non zero
BS output power setting	PRAT
Number of DPCH in each time slot under test	9
Power of each DPCH	1/9 of Base Station output power
Data content of DPCH	real life (sufficient irregular)

#### 5.3.6.1.2 Procedure

##### 5.3.6.1.2.1 3,84 Mcps TDD option

- 1) Measure the power of the spurious emissions by applying the measuring equipment with the settings as specified in table 5.3.6.1.2.1-1. The characteristics of the measurement filter with the bandwidth 3,84 MHz shall be RRC with roll-off  $\alpha = 0,22$ . The characteristics of the measurement filters with bandwidths 100 kHz and 1 MHz shall be approximately Gaussian (typical spectrum analyser filter). The centre frequency of the filters shall be stepped in contiguous steps over the frequency bands as specified in table 5.3.6.1.2.1-1. The time duration of each step shall be sufficiently long to capture one even (transmit) time slot.
- 2) If the BS is equipped with more than one Rx port, interchange the connections of the BS Rx ports and repeat the measurement according to 1).

**Table 5.3.6.1.2.1-1: Measurement equipment settings (3,84 Mcps TDD option)**

Stepped frequency range	Measurement bandwidth	Step width	Note	Detection mode
30 MHz to 1 GHz	100 kHz	100 kHz	With the exception of frequencies between 12,5 MHz below the first carrier frequency and 12,5 MHz above the last carrier frequency used by the BS.	true RMS
1 GHz to 1,900 GHz	1 MHz	1 MHz		
1,900 GHz to 1,980 GHz	3,84 MHz	200 kHz		
1,980 GHz to 2,010 GHz	1 MHz	1 MHz		
2,010 GHz to 2,025 GHz	3,84 MHz	200 kHz		
2,025 GHz to 2,500 GHz	1 MHz	1 MHz		
2,500 GHz to 2,620 GHz	3,84 MHz	200 kHz		
2,620 GHz to 12,75 GHz	1 MHz	1 MHz		

## 5.3.6.1.2.2 1,28 Mcps TDD option

- 1) Measure the power of the spurious emissions by applying the measuring equipment with the settings as specified in table 5.3.6.1.2.2-1. The characteristics of the measurement filter with the bandwidth 1,28 MHz shall be RRC with roll-off  $\alpha = 0,22$ . The characteristics of the measurement filters with bandwidths 100 kHz and 1 MHz shall be approximately Gaussian (typical spectrum analyser filter). The centre frequency of the filters shall be stepped in contiguous steps over the frequency bands as specified in table 5.3.6.1.2.2-1. The time duration of each step shall be sufficiently long to capture one transmit time slot.
- 2) If the BS is equipped with more than one Rx port, interchange the connections of the BS Rx ports and repeat the measurement according to 1).

**Table 5.3.6.1.2.2-1: Measurement equipment settings (1,28 Mcps TDD option)**

Stepped frequency range	Measurement bandwidth	Step width	Note	Detection mode
30 MHz to 1 GHz	100 kHz	100 kHz	With the exception of frequencies between 4 MHz below the first carrier frequency and 4 MHz above the last carrier frequency used by the BS.	true RMS
1 GHz to 1,900 GHz	1 MHz	1 MHz		
1,900 GHz to 1,980 GHz	1,28 MHz	200 kHz		
1,980 GHz to 2,010 GHz	1 MHz	1 MHz		
2,010 GHz to 2,025 GHz	1,28 MHz	200 kHz		
2,025 GHz to 2,500 GHz	1 MHz	1 MHz		
2,500 GHz to 2,620 GHz	1,28 MHz	200 kHz		
2,620 GHz to 12,75 GHz	1 MHz	1 MHz		

## 5.3.6.1.2.3 7,68 Mcps TDD option

- 1) Measure the power of the spurious emissions by applying the measuring equipment with the settings as specified in table 5.3.6.1.2.3-1. The characteristics of the measurement filter with the bandwidth 3,84 MHz shall be RRC with roll-off  $\alpha = 0,22$ . The characteristics of the measurement filters with bandwidths 100 kHz and 1 MHz shall be approximately Gaussian (typical spectrum analyser filter). The centre frequency of the filters shall be stepped in contiguous steps over the frequency bands as specified in table 5.3.6.1.2.3-1. The time duration of each step shall be sufficiently long to capture one even (transmit) time slot.
- 2) If the BS is equipped with more than one Rx port, interchange the connections of the BS Rx ports and repeat the measurement according to 1).

**Table 5.3.6.1.2.3-1: Measurement equipment settings (7,68 Mcps TDD option)**

Stepped frequency range	Measurement bandwidth	Step width	Note	Detection mode
30 MHz to 1 GHz	100 kHz	100 kHz	With the exception of frequencies between 25 MHz below the first carrier frequency and 25 MHz above the last carrier frequency used by the BS.	true RMS
1 GHz to 1,900 GHz	1 MHz	1 MHz		
1,900 GHz to 1,980 GHz	7,68 MHz	200 kHz		
1,980 GHz to 2,010 GHz	1 MHz	1 MHz		
2,010 GHz to 2,025 GHz	7,68 MHz	200 kHz		
2,025 GHz to 2,500 GHz	1 MHz	1 MHz		
2,500 GHz to 2,620 GHz	7,68 MHz	200 kHz		
2,620 GHz to 12,75 GHz	1 MHz	1 MHz		



### 5.3.6.2 Test requirements

The receiver spurious emissions measured according to clause 5.3.6.1.2 shall not exceed the limits specified in clause 4.2.7.2.

## 5.3.7 Receiver blocking characteristics

### 5.3.7.1 Method of test

#### 5.3.7.1.1 Initial conditions

Test environment: normal; see TS 125 142 [3], clause 5.9.

RF channels to be tested: M; see clause 5.1.

The BS shall be configured to operate as close to the centre of the operating band as possible.

- 1) Connect an UE simulator operating at the assigned channel frequency of the wanted signal and a signal generator to the antenna connector of one Rx port.
- 2) Terminate or disable any other Rx port not under test.
- 3) Start transmission from the BS tester to the BS using the UL reference measurement channel (12,2 kbit/s) defined in TS 125 105 [2], annex A. The level of the UE simulator signal measured at the BS antenna connector shall be set to -103 dBm for the 3,84 Mcps TDD option Wide Area BS, -89 dBm for the 3,84 Mcps TDD option Local Area BS, -104 dBm for the 1,28 Mcps TDD option Wide Area BS and -90 dBm for the 1,28 Mcps TDD option Local Area BS, -103 dBm for the 7,68 Mcps TDD option Wide Area BS and -89 dBm for the 7,68 Mcps TDD option Local Area BS, respectively.

#### 5.3.7.1.2 Procedure

##### 5.3.7.1.2.1 3,84 Mcps TDD option

- 1) Set the signal generator to produce an interfering signal at a frequency offset  $F_{uw}$  from the assigned channel frequency of the wanted signal which is given by:

$$F_{uw} = \pm (n \times 1 \text{ MHz});$$

where n shall be increased in integer steps from  $n = 10$  up to such a value that the centre frequency of the interfering signal covers the range from 1 MHz to 12,75 GHz. The interfering signal level measured at the antenna connector shall be set in dependency of its centre frequency, as specified in table 4.2.8.2.1-1, table 4.2.8.2.1-3 for the Wide Area BS and table 4.2.8.2.1-2 and table 4.2.8.2.1-4 for the Local Area BS respectively. The type of the interfering signal is either equivalent to a continuous wideband CDMA signal with one code of chip frequency 3,84 Mchip/s, filtered by an RRC transmit pulse-shaping filter with roll-off  $\alpha = 0,22$ , or a CW signal; see tables 4.2.8.2.1-1, 4.2.8.2.1-2, 4.2.8.2.1-3 and 4.2.8.2.1-4.

- 2) Measure the BER of the wanted signal at the BS receiver.
- 3) Interchange the connections of the BS Rx ports and repeat the measurements according to steps 1) and 2).

##### 5.3.7.1.2.2 1,28 Mcps TDD option

- 1) Set the signal generator to produce an interfering signal at a frequency offset  $F_{uw}$  from the assigned channel frequency of the wanted signal which is given by:

$$F_{uw} = \pm (3,2 + n) \times 1 \text{ MHz},$$

where  $n$  shall be increased in integer steps from  $n = 0$  up to such a value that the centre frequency of the interfering signal covers the range from 1 MHz to 12,75 GHz. The interfering signal level measured at the antenna connector shall be set in dependency of its centre frequency, as specified in table 4.2.8.2.2-1 and table 4.2.8.2.2-3 for the Wide Area BS and 13c and table 4.2.8.2.2-4 for the Local Area BS respectively. The type of the interfering signal is either equivalent to a continuous wideband CDMA signal with one code of chip frequency 1,28 Mchip/s, filtered by an RRC transmit pulse-shaping filter with roll-off  $\alpha = 0,22$ , or a CW signal; see tables 4.2.8.2.2-1, 4.2.8.2.2-2, 4.2.8.2.2-3 and 4.2.8.2.2-4.

- 2) Measure the BER of the wanted signal at the BS receiver.
- 3) Interchange the connections of the BS Rx ports and repeat the measurements according to steps 1) and 2).

#### 5.3.7.1.2.3 7,68 Mcps TDD option

- 1) Set the signal generator to produce an interfering signal at a frequency offset  $F_{uw}$  from the assigned channel frequency of the wanted signal which is given by:

$$F_{uw} = \pm (n \times 1 \text{ MHz});$$

where  $n$  shall be increased in integer steps from  $n = 20$  up to such a value that the centre frequency of the interfering signal covers the range from 1 MHz to 12,75 GHz. The interfering signal level measured at the antenna connector shall be set in dependency of its centre frequency, as specified in table 4.2.8.2.3-1 and table 4.2.8.2.3-3 for the Wide Area BS and table 4.2.8.2.3-2 and table 4.2.8.2.3-4 for the Local Area BS respectively. The type of the interfering signal is either equivalent to a continuous wideband CDMA signal with one code of chip frequency 7,68 Mchip/s, filtered by an RRC transmit pulse-shaping filter with roll-off  $\alpha = 0,22$ , or a CW signal; see tables 4.2.8.2.3-1, 4.2.8.2.3-2, 4.2.8.2.3-3 and 4.2.8.2.3-4.

- 2) Measure the BER of the wanted signal at the BS receiver.
- 3) Interchange the connections of the BS Rx ports and repeat the measurements according to steps 1) and 2).

### 5.3.7.2 Test requirements

In all measurements made according to clause 5.3.7.1.2, the BER shall not exceed 0,001.

NOTE: TS 125 142 [3], annex F describes the procedure for BER tests taking into account the statistical consequence of frequent repetition of BER measurements within the blocking test. The consequence is: a DUT exactly on the limit may fail due to the statistical nature 2,55 times (mean value) in 12 750 BER measurements using the predefined wrong decision probability of 0,02 %. If the fail cases are  $\leq 12$ , it is allowed to repeat the fail cases 1 time before the final verdict.

## 5.3.8 Receiver intermodulation characteristics

### 5.3.8.1 Method of test

#### 5.3.8.1.1 Initial conditions

Test environment: normal; see TS 125 142 [3], clause 5.9.

RF channels to be tested: B, M and T; see clause 5.1.

- 1) Connect an UE simulator operating at the assigned channel frequency of the wanted signal and two signal generators to the antenna connector of one Rx port.
- 2) Terminate or disable any other Rx port not under test.
- 3) Start transmission from the BS tester to the BS using the UL reference measurement channel (12,2 kbit/s) defined in TS 125 105 [2], annex A. The level of the UE simulator signal measured at the BS antenna connector shall be set to as specified in tables 5.3.8.1.1-1, 5.3.8.1.1-2 and 5.3.8.1.1-3.

**Table 5.3.8.1.1-1: Wanted signal level for intermodulation characteristics testing (3,84 Mcps TDD option)**

BS class	Wanted signal level
Wide Area BS	-103 dBm
Local Area BS	-89 dBm

**Table 5.3.8.1.1-2: Wanted signal level for intermodulation characteristics testing (1,28 Mcps TDD option)**

BS class	Wanted signal level
Wide Area BS	-104 dBm
Local Area BS	-90 dBm

**Table 5.3.8.1.1-3: Wanted signal level for intermodulation characteristics testing (7,68 Mcps TDD option)**

BS class	Wanted signal level
Wide Area BS	-103 dBm
Local Area BS	-89 dBm

- 4) Set the first signal generator to produce a CW signal with a level measured at the BS antenna connector as specified in table 4.2.9.2.1-1 for the 3,84 Mcps TDD option and table 4.2.9.2.2-1 for the 1,28 Mcps TDD option respectively.
- 5) Set the second signal generator to produce an interfering signal equivalent to a wideband CDMA signal with one code of chip frequency 3,84 Mchip/s for the 3,84 Mcps TDD option, 1,28 Mcps for the 1,28 Mcps TDD option and 7,68 Mcps for the 7,68 Mcps TDD option respectively, filtered by an RRC transmit pulse-shaping filter with roll-off  $\alpha = 0,22$ . The level of the signal measured at the BS antenna connector shall be set as specified in table 4.2.9.2.1-1 for the 3,84 Mcps TDD option, table 4.2.9.2.2-1 for the 1,28 Mcps TDD option and table 4.2.9.2.3-1 for the 7,68 Mcps TDD option respectively.

### 5.3.8.1.2 Procedure

#### 5.3.8.1.2.1 3,84 Mcps TDD option

- 1) The frequency of the first and the second signal generator shall be set to 10 MHz and 20 MHz, respectively, above the assigned channel frequency of the wanted signal.
- 2) Measure the BER of the wanted signal at the BS receiver.
- 3) The frequency of the first and the second signal generator shall be set to 10 MHz and 20 MHz, respectively, below the assigned channel frequency of the wanted signal.
- 4) Measure the BER of the wanted signal at the BS receiver.
- 5) Interchange the connections of the BS Rx ports and repeat the measurements according to steps 1) to 4).

#### 5.3.8.1.2.2 1,28 Mcps TDD option

- 1) The frequency of the first and the second signal generator shall be set to 3,2 MHz and 6,4 MHz, respectively, above the assigned channel frequency of the wanted signal.
- 2) Measure the BER of the wanted signal at the BS receiver.
- 3) The frequency of the first and the second signal generator shall be set to 3,2 MHz and 6,4 MHz, respectively, below the assigned channel frequency of the wanted signal.
- 4) Measure the BER of the wanted signal at the BS receiver.
- 5) Interchange the connections of the BS Rx ports and repeat the measurements according to steps 1) to 4).

### 5.3.8.1.2.3 7,68 Mcps TDD option

- 1) The frequency of the first and the second signal generator shall be set to 20 MHz and 40 MHz, respectively, above the assigned channel frequency of the wanted signal.
- 2) Measure the BER of the wanted signal at the BS receiver.
- 3) The frequency of the first and the second signal generator shall be set to 20 MHz and 40 MHz, respectively, below the assigned channel frequency of the wanted signal.
- 4) Measure the BER of the wanted signal at the BS receiver.
- 5) Interchange the connections of the BS Rx ports and repeat the measurements according to steps 1) to 4).

### 5.3.8.2 Test requirements

The BER measured according clause 5.3.8.1.2 to shall not exceed 0,001.

## 5.3.9 Receiver adjacent channel selectivity

### 5.3.9.1 Method of test

#### 5.3.9.1.1 Initial conditions

##### 5.3.9.1.1.1 General initial conditions

Test environment: normal; see TS 125 142 [3], clause 5.9.

RF channels to be tested: B, M and T; see clause 5.1.

#### 5.3.9.1.1.2 3,84 Mcps TDD option

- 1) Connect an UE simulator operating at the assigned channel frequency of the wanted signal and a signal generator used to produce the interfering signal in the adjacent channel to the antenna connector of one Rx port.
- 2) Terminate or disable any other Rx port not under test.
- 3) Start transmission from the BS tester to the BS using the UL reference measurement channel (12,2 kbit/s) defined in TS 125 105 [2], annex A. The level of the UE simulator signal measured at the BS antenna connector shall be adjust to the value specified in table 4.2.10.2.1-1 for the Wide Area BS and table 4.2.10.2.1-2 for the local Area BS respectively.
- 4) Set the signal generator to produce an interfering signal that is equivalent to a continuous wideband CDMA signal with one code of chip frequency 3,84 Mchip/s, filtered by an RRC transmit pulse-shaping filter with roll-off  $\alpha = 0,22$ . The level of the interfering signal measured at the BS antenna connector shall be adjusted to the value specified in table 4.2.10.2.1-1 for the Wide Area BS and table 4.2.10.2.1-2 for the local Area BS respectively.

#### 5.3.9.1.1.3 1,28 Mcps TDD option

- 1) Connect an UE simulator operating at the assigned channel frequency of the wanted signal and a signal generator used to produce the interfering signal in the adjacent channel to the antenna connector of one Rx port.
- 2) Terminate or disable any other Rx port not under test.
- 3) Start transmission from the BS tester to the BS using the UL reference measurement channel (12,2 kbit/s) defined in TS 125 105 [2], annex A. The level of the UE simulator signal measured at the BS antenna connector shall be adjusted to the value specified in table 4.2.10.2.2-1 for the Wide Area BS and table 4.2.10.2.2-2 for the local Area BS respectively.

- 4) Set the signal generator to produce an interfering signal that is equivalent to a continuous wideband CDMA signal with one code of chip frequency 1,28 Mchip/s, filtered by an RRC transmit pulse-shaping filter with roll-off  $\alpha = 0,22$ . The level of the interfering signal measured at the BS antenna connector shall be adjusted to the value specified in table 4.2.10.2.2-1 for the Wide Area BS and table 4.2.10.2.2-2 for the local Area BS respectively.

#### 5.3.9.1.1.4 7,68 Mcps TDD option

- 1) Connect an UE simulator operating at the assigned channel frequency of the wanted signal and a signal generator used to produce the interfering signal in the adjacent channel to the antenna connector of one Rx port.
- 2) Terminate or disable any other Rx port not under test.
- 3) Start transmission from the BS tester to the BS using the UL reference measurement channel (12,2 kbit/s) defined in TS 125 105 [2], annex A. The level of the UE simulator signal measured at the BS antenna connector shall be adjust to the value specified in table 4.2.10.2.3-1 for the Wide Area BS and table 4.2.10.2.3-2 for the local Area BS respectively.
- 4) Set the signal generator to produce an interfering signal that is equivalent to a continuous wideband CDMA signal with one code of chip frequency 7,68 Mchip/s, filtered by an RRC transmit pulse-shaping filter with roll-off  $\alpha = 0,22$ . The level of the interfering signal measured at the BS antenna connector shall be adjusted to the value specified in table 4.2.10.2.3-1 for the Wide Area BS and table 4.2.10.2.3-2 for the local Area BS respectively.

#### 5.3.9.1.2 Procedure

##### 5.3.9.1.2.1 3,84 Mcps TDD option

- 1) Set the centre frequency of the interfering signal to 5 MHz above the assigned channel frequency of the wanted signal.
- 2) Measure the BER of the wanted signal at the BS receiver.
- 3) Set the centre frequency of the interfering signal to 5 MHz below the assigned channel frequency of the wanted signal.
- 4) Measure the BER of the wanted signal at the BS receiver.
- 5) Interchange the connections of the BS Rx ports and repeat the measurements according to steps 1) to 4).

##### 5.3.9.1.2.2 1,28 Mcps TDD option

- 1) Set the centre frequency of the interfering signal to 1,6 MHz above the assigned channel frequency of the wanted signal.
- 2) Measure the BER of the wanted signal at the BS receiver.
- 3) Set the centre frequency of the interfering signal to 1,6 MHz below the assigned channel frequency of the wanted signal.
- 4) Measure the BER of the wanted signal at the BS receiver.
- 5) Interchange the connections of the BS Rx ports and repeat the measurements according to steps 1) to 4).

##### 5.3.9.1.2.3 7,68 Mcps TDD option

- 1) Set the centre frequency of the interfering signal to 10 MHz above the assigned channel frequency of the wanted signal.
- 2) Measure the BER of the wanted signal at the BS receiver.
- 3) Set the centre frequency of the interfering signal to 10 MHz below the assigned channel frequency of the wanted signal.

- 4) Measure the BER of the wanted signal at the BS receiver.
- 5) Interchange the connections of the BS Rx ports and repeat the measurements according to steps 1) to 4).

#### 5.3.9.1.3 Test requirements

The BER measured according clause 5.3.9.1.2 to shall not exceed 0,001.

## Annex A (normative): HS Requirements and conformance Test specifications Table (HS-RTT)

The HS Requirements and conformance Test specifications Table (HS-RTT) in table A-1 serves a number of purposes, as follows:

- it provides a statement of all the requirements in words and by cross reference to (a) specific clause(s) in the present document or to (a) specific clause(s) in (a) specific referenced document(s);
- it provides a statement of all the test procedures corresponding to those requirements by cross reference to (a) specific clause(s) in the present document or to (a) specific clause(s) in (a) specific referenced document(s);
- it qualifies each requirement to be either:
  - Unconditional: meaning that the requirement applies in all circumstances; or
  - Conditional: meaning that the requirement is dependent on the manufacturer having chosen to support optional functionality defined within the schedule.
- in the case of Conditional requirements, it associates the requirement with the particular optional service or functionality;
- it qualifies each test procedure to be either:
  - Essential: meaning that it is included with the Essential Radio Test Suite and therefore the requirement shall be demonstrated to be met in accordance with the referenced procedures;
  - Other: meaning that the test procedure is illustrative but other means of demonstrating compliance with the requirement are permitted.

**Table A-1: HS Requirements and conformance Test specifications Table (HS-RTT)**

<b>Harmonized Standard EN 301 908-7</b>						
The following requirements and test specifications are relevant to the presumption of conformity under the article 3.2 of the R&TTE Directive						
<b>Requirement</b>			<b>Requirement Conditionality</b>		<b>Test Specification</b>	
<b>No</b>	<b>Description</b>	<b>Reference: Clause No</b>	<b>U/C</b>	<b>Condition</b>	<b>E/O</b>	<b>Reference: Clause No</b>
1	Spectrum emission mask	4.2.2	U		E	5.3.1
2	Transmitter adjacent channel leakage power ratio	4.2.3	U		E	5.3.2
3	Transmitter spurious emissions	4.2.4	U		E	5.3.3
4	Base station maximum output power	4.2.5	U		E	5.3.4
5	Transmit intermodulation	4.2.6	U		E	5.3.5
6	Receiver spurious emissions	4.2.7	U		E	5.3.6
7	Receiver blocking characteristics	4.2.8	U		E	5.3.7
8	Receiver intermodulation characteristics	4.2.9	U		E	5.3.8
9	Receiver adjacent channel selectivity	4.2.10	U		E	5.3.9

### Key to columns:

#### Essential Requirement:

**No** A unique identifier for one row of the table which may be used to identify a requirement or its test specification.

**Description** A textual reference to the requirement.

**Clause Number** Identification of clause(s) defining the requirement in the present document unless another document is referenced explicitly.

**Requirement Conditionality:**

**U/C** Indicates whether the requirement is to be *unconditionally* applicable (U) or is *conditional* upon the manufacturers claimed functionality of the equipment (C).

**Condition** Explains the conditions when the requirement shall or shall not be applicable for a technical requirement which is classified "conditional".

**Test Specification:**

**E/O** Indicates whether the test specification forms part of the Essential Radio Test Suite (E) or whether it is one of the Other Test Suite (O).

**NOTE:** All tests whether "E" or "O" are relevant to the requirements. Rows designated "E" collectively make up the Essential Radio Test Suite; those designated "O" make up the Other Test Suite; for those designated "X" there is no test specified corresponding to the requirement. The completion of all tests classified "E" as specified with satisfactory outcomes is a necessary condition for a presumption of conformity. Compliance with requirements associated with tests classified "O" or "X" is a necessary condition for presumption of conformity, although conformance with the requirement may be claimed by an equivalent test or by manufacturer's assertion supported by appropriate entries in the technical construction file.

**Clause Number** Identification of clause(s) defining the test specification in the present document unless another document is referenced explicitly. Where no test is specified (that is, where the previous field is "X") this field remains blank.



---

## Annex B (normative): BS configurations

### B.1 Receiver Diversity

For the tests in clause 5, the specified test signals shall be applied to one receiver antenna connector, with the remaining receiver antenna connectors being terminated with 50  $\Omega$ .

---

### B.2 Power Supply options

If the BS is supplied with a number of different power supply configurations, it may not be necessary to test RF parameters for each of the power supply options, provided that it can be demonstrated that the range of conditions over which the equipment is tested is at least as great as the range of conditions due to any of the power supply configurations.

This applies particularly if a BS contains a DC rail which can be supplied either externally or from an internal mains power supply. In this case, the conditions of extreme power supply for the mains power supply options can be tested by testing only the external DC supply option. The range of DC input voltages for the test should be sufficient to verify the performance with any of the power supplies, over its range of operating conditions within the BS, including variation of mains input voltage, temperature and output current.

---

### B.3 Ancillary RF amplifiers

The requirements of the present document shall be met with the ancillary RF amplifier fitted. At tests according to clause 5 for Tx and Rx respectively, the ancillary amplifier is connected to the BS by a connecting network (including any cable(s), attenuator(s), etc.) with applicable loss to make sure the appropriate operating conditions of the ancillary amplifier and the BS. The applicable connecting network loss range is declared by the manufacturer. Other characteristics and the temperature dependence of the attenuation of the connecting network are neglected. The actual attenuation value of the connecting network is chosen for each test as one of the applicable extreme values. The lowest value is used unless otherwise stated.

Sufficient tests should be repeated with the ancillary amplifier fitted and, if it is optional, without the ancillary RF amplifier to verify that the BS meets the requirements of the present document in both cases.

---

### B.4 BS using antenna arrays

A BS may be configured with a multiple antenna port connection for some or all of its TRXs or with an antenna array related to one cell (not one array per TRX). This clause applies to a BS which meets at least one of the following conditions:

- the transmitter output signals from one or more TRX appear at more than one antenna port; or
- there is more than one receiver antenna port for a TRX or per cell and an input signal is required at more than one port for the correct operation of the receiver (note that diversity reception does not meet this requirement) thus the outputs from the transmitters as well as the inputs to the receivers are directly connected to several antennas (known as "aircombining").

If a BS is used, in normal operation, in conjunction with an antenna system which contains filters or active elements which are necessary to meet the UTRA requirements, the tests of conformance may be performed on a system comprising the BS together with these elements, supplied separately for the purposes of testing. In this case, it must be demonstrated that the performance of the configuration under test is representative of the system in normal operation, and the conformance assessment is only applicable when the BS is used with the antenna system.

For testing of conformance of such a BS, the following procedure may be used.

## B.4.1 Receiver tests

For each test, the test signals applied to the receiver antenna connectors shall be such that the sum of the powers of the signals applied equals the power of the test signal(s) specified in the test.

An example of a suitable test configuration is shown in figure B.4.1-1.

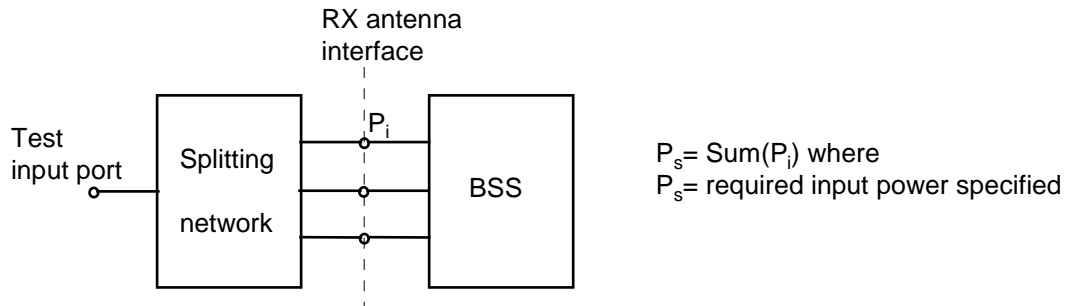

**Figure B.4.1-1: Receiver test set up**

For spurious emissions from the receiver antenna connector, the test may be performed separately for each receiver antenna connector.

## B.4.2 Transmitter tests

For each test, the conformance requirement shall be met by the sum of the signals emitted by each transmitter antenna connector. This may be assessed by separately measuring the signals emitted by each antenna connector and summing the results, or by combining the signals and performing a single measurement. The characteristics (e.g. amplitude and phase) of the combining network should be such that the power of the combined signal is maximized.

An example of a suitable test configuration is shown in figure B.4.2-1.

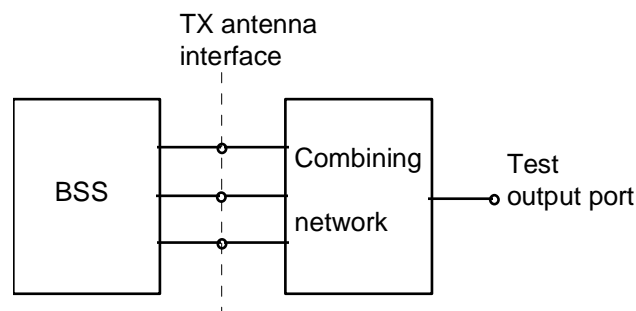

**Figure B.4.2-1: Transmitter test setup**

For intermodulation attenuation, the test may be performed separately for each transmitter antenna connector.

---

## Annex C (informative): Environmental profile specification

The following environmental conditions may be declared by the supplier:

- barometric pressure: minimum and maximum;
- temperature: minimum and maximum;
- relative humidity: minimum and maximum;
- power supply: lower and upper voltage limit.

When operating outside the boundary limits of the declared operational environmental profile the equipment should not make ineffective use of the radio frequency spectrum so as to cause harmful interference.

---

## Annex D (informative): The EN title in the official languages

The enlargement of the European Union (EU) resulted in a requirement from the EU for a larger number of languages for the translation of the titles of Harmonized Standards and mandated ENs that are to be listed in the Official Journal to support the implementation of this legislation.

For this reason the title translation concerning the present document can be consulted via the [e-approval](#) application.

---

## Annex E (informative): Bibliography

ETSI TR 125 942: "Universal Mobile Telecommunications System (UMTS); Radio Frequency (RF) system scenarios (3GPP TR 25.942 version 6.4.0 Release 6)".

Directive 2004/108/EC of the European Parliament and of the Council of 15 December 2004 on the approximation of the laws of the Member States relating to electromagnetic compatibility and repealing Directive 89/336/EEC (text with EEA relevance (EMC Directive).

Council Directive 73/23/EEC of 19 February 1973 on the harmonization of the laws of Member States relating to electrical equipment designed for use within certain voltage limits (LV Directive).

CEPT/ERC/REC 74-01E (Siófok 1998, Nice 1999, Sesimbra 2002, Hradec Kralove 2005): "Unwanted Emissions in the Spurious Domain".

---

## History

<b>Document history</b>		
V1.1.1	January 2002	Publication
V2.2.1	October 2003	Publication
V2.2.2	January 2005	Publication
V3.2.1	May 2007	Publication
V4.1.1	April 2009	Public Enquiry PE 20090828: 2009-04-30 to 2009-08-28
V4.1.2	December 2009	Vote V 20100219: 2009-12-21 to 2010-02-19
V4.2.1	March 2010	Publication