

Draft **ETSI EN 301 908-7** V3.0.0 (2006-06)

Candidate Harmonized European Standard (Telecommunications series)

**Electromagnetic compatibility
and Radio spectrum Matters (ERM);
Base Stations (BS), Repeaters and User Equipment (UE) for
IMT-2000 Third-Generation cellular networks;
Part 7: Harmonized EN for IMT-2000,
CDMA TDD (UTRA TDD) (BS)
covering essential requirements
of article 3.2 of the R&TTE Directive**



Reference

REN/ERM-TFES-003-7

Keywords

3G, 3GPP, cell, digital, IMT-2000, mobile, radio, regulation, TD-CDMA, TDD, UMTS

ETSI

650 Route des Lucioles
F-06921 Sophia Antipolis Cedex - FRANCE

Tel.: +33 4 92 94 42 00 Fax: +33 4 93 65 47 16

Siret N° 348 623 562 00017 - NAF 742 C
Association à but non lucratif enregistrée à la
Sous-Préfecture de Grasse (06) N° 7803/88

Important notice

Individual copies of the present document can be downloaded from:

<http://www.etsi.org>

The present document may be made available in more than one electronic version or in print. In any case of existing or perceived difference in contents between such versions, the reference version is the Portable Document Format (PDF). In case of dispute, the reference shall be the printing on ETSI printers of the PDF version kept on a specific network drive within ETSI Secretariat.

Users of the present document should be aware that the document may be subject to revision or change of status. Information on the current status of this and other ETSI documents is available at

<http://portal.etsi.org/tb/status/status.asp>

If you find errors in the present document, please send your comment to one of the following services:

http://portal.etsi.org/chaicor/ETSI_support.asp

Copyright Notification

No part may be reproduced except as authorized by written permission.
The copyright and the foregoing restriction extend to reproduction in all media.

© European Telecommunications Standards Institute 2006.
All rights reserved.

DECTTM, **PLUGTESTS**TM and **UMTS**TM are Trade Marks of ETSI registered for the benefit of its Members.
TIPHONTM and the **TIPHON logo** are Trade Marks currently being registered by ETSI for the benefit of its Members.
3GPPTM is a Trade Mark of ETSI registered for the benefit of its Members and of the 3GPP Organizational Partners.

Contents

Intellectual Property Rights	6
Foreword.....	6
1 Scope	8
2 References	8
3 Definitions, symbols and abbreviations	9
3.1 Definitions	9
3.2 Symbols.....	10
3.3 Abbreviations	10
4 Technical requirements specifications	11
4.1 Environmental profile.....	11
4.2 Conformance requirements	11
4.2.1 Introduction.....	11
4.2.2 Spectrum emission mask	11
4.2.2.1 Definition	11
4.2.2.1.1 3,84 Mcps TDD option.....	11
4.2.2.1.2 1,28 Mcps TDD option.....	12
4.2.2.2 Limits	12
4.2.2.2.1 3,84 Mcps TDD option.....	12
4.2.2.2.2 1,28 Mcps TDD option.....	13
4.2.2.3 Conformance.....	14
4.2.3 Transmitter adjacent channel leakage power ratio.....	14
4.2.3.1 Definition	14
4.2.3.2 Limits	14
4.2.3.2.1 General requirements.....	14
4.2.3.2.2 Co-existence with UTRA-FDD	15
4.2.3.2.3 Co-existence with unsynchronized UTRA TDD on adjacent channels	16
4.2.3.3 Conformance.....	16
4.2.4 Transmitter spurious emissions.....	16
4.2.4.1 Definition	16
4.2.4.2 Limits	17
4.2.4.2.1 General requirements.....	17
4.2.4.2.2 Co-existence with GSM 900.....	18
4.2.4.2.3 Co-existence with DCS 1800	19
4.2.4.2.4 Co-existence with UTRA FDD	19
4.2.4.2.5 Co-existence with unsynchronized TDD.....	19
4.2.4.3 Conformance.....	20
4.2.5 Base station maximum output power.....	20
4.2.5.1 Definition	20
4.2.5.2 Limits	20
4.2.5.3 Conformance.....	20
4.2.6 Transmit intermodulation	20
4.2.6.1 Definition	20
4.2.6.2 Limits	20
4.2.6.2.1 3,84 Mcps TDD option.....	20
4.2.6.2.2 1,28 Mcps TDD option.....	21
4.2.6.3 Conformance.....	21
4.2.7 Receiver spurious emissions	21
4.2.7.1 Definition	21
4.2.7.2 Limits	21
4.2.7.2.1 3,84 Mcps TDD option.....	21
4.2.7.2.2 1,28 Mcps TDD option.....	22
4.2.7.3 Conformance.....	22
4.2.8 Receiver blocking characteristics	22
4.2.8.1 Definition	22

4.2.8.2	Limits	22
4.2.8.2.1	3,84 Mcps TDD option	22
4.2.8.2.2	1,28 Mcps TDD option	23
4.2.8.3	Conformance	25
4.2.9	Receiver intermodulation characteristics	25
4.2.9.1	Definition	25
4.2.9.2	Limits	25
4.2.9.2.1	3,84 Mcps TDD option	25
4.2.9.2.2	1,28 Mcps TDD option	25
4.2.9.3	Conformance	26
4.2.10	Receiver adjacent channel selectivity	26
4.2.10.1	Definition	26
4.2.10.2	Limits	26
4.2.10.2.1	3,84 Mcps TDD option	26
4.2.10.2.2	1,28 Mcps TDD option	27
4.2.10.3	Conformance	27
5	Testing for compliance with technical requirements	27
5.1	Conditions for testing	27
5.2	Interpretation of the measurement results	28
5.3	Essential radio test suites	29
5.3.1	Spectrum emission mask	29
5.3.1.1	Method of test	29
5.3.1.1.1	Initial conditions	29
5.3.1.1.2	Procedure	31
5.3.1.2	Test requirements	31
5.3.1.2.1	3,84 Mcps TDD option	31
5.3.1.2.2	1,28 Mcps TDD option	32
5.3.2	Transmitter adjacent channel leakage power ratio	32
5.3.2.1	Method of test	32
5.3.2.1.1	Initial conditions	32
5.3.2.1.2	Procedure	34
5.3.2.2	Test requirements	35
5.3.2.2.1	3,84 Mcps TDD option	35
5.3.2.2.2	1,28 Mcps TDD option	35
5.3.3	Transmitter spurious emissions	35
5.3.3.1	Method of test	35
5.3.3.1.1	Initial conditions	35
5.3.3.1.2	Procedure	37
5.3.3.2	Test requirements	37
5.3.4	Base station maximum output power	37
5.3.4.1	Method of test	37
5.3.4.1.1	Initial conditions	37
5.3.4.1.2	Procedure	38
5.3.4.2	Test requirements	39
5.3.5	Transmit intermodulation	39
5.3.5.1	Method of test	39
5.3.5.1.1	Initial conditions	39
5.3.5.1.2	Procedure	42
5.3.5.2	Test requirements	42
5.3.6	Receiver spurious emissions	43
5.3.6.1	Method of test	43
5.3.6.1.1	Initial conditions	43
5.3.6.1.2	Procedure	44
5.3.6.2	Test requirements	44
5.3.7	Receiver blocking characteristics	45
5.3.7.1	Method of test	45
5.3.7.1.1	Initial conditions	45
5.3.7.1.2	Procedure	45
5.3.7.2	Test requirements	46
5.3.8	Receiver intermodulation characteristics	46
5.3.8.1	Method of test	46

5.3.8.1.1	Initial conditions	46
5.3.8.1.2	Procedure	47
5.3.8.2	Test requirements	47
5.3.9	Receiver adjacent channel selectivity	47
5.3.9.1	Method of test	47
5.3.9.1.1	Initial conditions	47
5.3.9.1.2	Procedure	48
5.3.9.1.3	Test requirements	48
Annex A (normative):	EN Requirements Table (EN-RT)	49
Annex B (normative):	BS configurations	50
B.1	Receiver Diversity	50
B.2	Power Supply options	50
B.3	Ancillary RF amplifiers	50
B.4	BS using antenna arrays	50
B.4.1	Receiver tests	51
B.4.2	Transmitter tests	51
Annex C (informative):	Environmental profile specification	52
Annex D (informative):	Bibliography	53
Annex E (informative):	The EN title in the official languages	54
History		55

Intellectual Property Rights

IPRs essential or potentially essential to the present document may have been declared to ETSI. The information pertaining to these essential IPRs, if any, is publicly available for **ETSI members and non-members**, and can be found in ETSI SR 000 314: *"Intellectual Property Rights (IPRs); Essential, or potentially Essential, IPRs notified to ETSI in respect of ETSI standards"*, which is available from the ETSI Secretariat. Latest updates are available on the ETSI Web server (<http://webapp.etsi.org/IPR/home.asp>).

Pursuant to the ETSI IPR Policy, no investigation, including IPR searches, has been carried out by ETSI. No guarantee can be given as to the existence of other IPRs not referenced in ETSI SR 000 314 (or the updates on the ETSI Web server) which are, or may be, or may become, essential to the present document.

Foreword

This Candidate Harmonized European Standard (Telecommunications series) has been produced by ETSI Technical Committee Electromagnetic compatibility and Radio spectrum Matters (ERM), and is now submitted for the Public Enquiry phase of the ETSI standards Two-step Approval Procedure.

The present document has been produced by ETSI in response to a mandate from the European Commission issued under Council Directive 98/34/EC (as amended) laying down a procedure for the provision of information in the field of technical standards and regulations.

The present document is intended to become a Harmonized Standard, the reference of which will be published in the Official Journal of the European Communities referencing the Directive 1999/5/EC [1] of the European Parliament and of the Council of 9 March 1999 on radio equipment and telecommunications terminal equipment and the mutual recognition of their conformity ("the R&TTE Directive").

The present document is part 7 of a multi-part deliverable covering the Base Stations (BS), Repeaters and User Equipment (UE) for IMT-2000 Third-Generation cellular networks, as identified below:

- Part 1: "Harmonized EN for IMT-2000, introduction and common requirements, covering essential requirements of article 3.2 of the R&TTE Directive";
- Part 2: "Harmonized EN for IMT-2000, CDMA Direct Spread (UTRA FDD) (UE) covering essential requirements of article 3.2 of the R&TTE Directive";
- Part 3: "Harmonized EN for IMT-2000, CDMA Direct Spread (UTRA FDD) (BS) covering essential requirements of article 3.2 of the R&TTE Directive";
- Part 4: "Harmonized EN for IMT-2000, CDMA Multi-Carrier (cdma2000) (UE) covering essential requirements of article 3.2 of the R&TTE Directive";
- Part 5: "Harmonized EN for IMT-2000, CDMA Multi-Carrier (cdma2000) (BS and Repeaters) covering essential requirements of article 3.2 of the R&TTE Directive";
- Part 6: "Harmonized EN for IMT-2000, CDMA TDD (UTRA TDD) (UE) covering essential requirements of article 3.2 of the R&TTE Directive";
- Part 7: "Harmonized EN for IMT-2000, CDMA TDD (UTRA TDD) (BS) covering essential requirements of article 3.2 of the R&TTE Directive";**
- Part 8: "Harmonized EN for IMT-2000, TDMA Single-Carrier (UWC 136) (UE) covering essential requirements of article 3.2 of the R&TTE Directive";
- Part 9: "Harmonized EN for IMT-2000, TDMA Single-Carrier (UWC 136) (BS) covering essential requirements of article 3.2 of the R&TTE Directive";
- Part 10: "Harmonized EN for IMT-2000 FDMA/TDMA (DECT) covering essential requirements of article 3.2 of the R&TTE Directive";

Part 11: "Harmonized EN for IMT-2000, CDMA Direct Spread (UTRA FDD) (Repeaters) covering essential requirements of article 3.2 of the R&TTE Directive".

Part 12: " Harmonized EN for IMT-2000, CDMA Multi-Carrier (cdma2000) (Repeater) covering essential requirements of article 3.2 of the R&TTE Directive ".

Technical specifications relevant to Directive 1999/5/EC [1] are given in annex A in the present document and annex A of EN 301 908-1 [7].

Proposed national transposition dates	
Date of latest announcement of this EN (doa):	3 months after ETSI publication
Date of latest publication of new National Standard or endorsement of this EN (dop/e):	6 months after doa
Date of withdrawal of any conflicting National Standard (dow):	36 months after doa

1 Scope

The present document applies to the following radio equipment type:

- Base stations for IMT-2000 CDMA TDD (UTRA TDD).

This radio equipment type is capable of operating in all or any part of the frequency bands given in table 1.

Table 1: CDMA TDD base station frequency bands

Operating band	Direction of transmission	CDMA TDD base station frequency bands
A	Transmit and Receive	1900 MHz to 1920 MHz
	Transmit and Receive	2010 MHz to 2025 MHz
D	Transmit and Receive	2570 MHz to 2620 MHz

The requirements in the present document apply to both Wide Area base stations and Local Area base stations unless otherwise stated.

IMT-2000 CDMA TDD (UTRA TDD) supports two options of the TDD mode with the chip rates of 3,84 Mchip/s and 1,28 Mchip/s. These two options are called the 3,84 Mcps TDD option and the 1,28 Mchip/s TDD option respectively. The requirements are listed in different subsections only if the parameters deviate.

The present document covers requirements for 3,84 Mcps TDD option base station for Release 99, 4, 5, 6 and 7 and for 1,28 Mcps TDD option base stations for Release 4, 5, 6 and 7.

For general purpose base stations of Release 99 and 4 only the requirements for Wide Area base stations shall apply.

The present document is intended to cover the provisions of Directive 1999/5/EC [1] (R&TTE Directive) article 3.2, which states that "[...] radio equipment shall be so constructed that it effectively uses the spectrum allocated to terrestrial/space radio communications and orbital resources so as to avoid harmful interference".

In addition to the present document, other ENs that specify technical requirements in respect of essential requirements under other parts of article 3 of the R&TTE Directive [1] will apply to equipment within the scope of the present document.

NOTE: A list of such ENs is included on the web site: <http://www.newapproach.org/>.

2 References

The following documents contain provisions which, through reference in this text, constitute provisions of the present document.

- References are either specific (identified by date of publication and/or edition number or version number) or non-specific.
- For a specific reference, subsequent revisions do not apply.
- For a non-specific reference, the latest version applies.

Referenced documents which are not found to be publicly available in the expected location might be found at <http://docbox.etsi.org/Reference>.

- [1] Directive 1999/5/EC of the European Parliament and of the Council of 9 March 1999 on radio equipment and telecommunications terminal equipment and the mutual recognition of their conformity (R&TTE Directive).
- [2] ETSI TR 100 028 (V1.4.1) (all parts): "Electromagnetic compatibility and Radio spectrum Matters (ERM); Uncertainties in the measurement of mobile radio equipment characteristics".
- [3] ETSI TS 125 105 (V7.1.0): "Universal Mobile Telecommunications System (UMTS); Base Station (BS) radio transmission and reception (TDD) (3GPP TS 25.105 version 7.1.0 Release 7)".

- [4] ETSI TS 125 142 (V7.1.0): "Universal Mobile Telecommunications System (UMTS); Base Station (BS) conformance testing (TDD) (3GPP TS 25.142 version 7.1.0 Release 7)".
- [5] ITU-R Recommendation SM.329-10 (2003): "Unwanted emissions in the spurious domain".
- [6] ETSI EN 301 489 (all parts): "Electromagnetic compatibility and Radio spectrum Matters (ERM); ElectroMagnetic Compatibility (EMC) standard for radio equipment and services".
- [7] ETSI EN 301 908-1: "Electromagnetic compatibility and Radio spectrum Matters (ERM); Base Stations (BS), Repeaters and User Equipment (UE) for IMT-2000 Third-Generation cellular networks; Part 1: Harmonized EN for IMT-2000, introduction and common requirements, covering essential requirements of article 3.2 of the R&TTE Directive".

3 Definitions, symbols and abbreviations

3.1 Definitions

For the purposes of the present document, the terms and definitions given in the R&TTE Directive [1] and the following apply:

ancillary RF amplifier: piece of equipment, which when connected by RF coaxial cables to the BS, has the primary function to provide amplification between the transmit and/or receive antenna connector of a BS and an antenna without requiring any control signal to fulfil its amplifying function

B: appropriate frequency in the Bottom of the operating frequency band of the BS: "RF channel"

base station class: wide area base station or local area base station, as declared by the manufacturer

DPCHo: mechanism used to simulate an individual intracell interferer in the cell with one code and a spreading factor of 16

environmental profile: range of environmental conditions under which equipment within the scope of EN 301 908-7 is required to comply with the provisions of EN 301 908-7

Fuw: frequency offset of the unwanted interfering signal from the assigned channel frequency of the wanted signal

local area base station: base station, characterized by requirements derived from Pico Cell scenarios with a BS to UE coupling loss equals to 45 dB

M: appropriate frequency in the Middle of the operating frequency band of the BS: "RF channel"

maximum output power (Pmax): mean power level per carrier of the base station measured at the antenna connector in a specified reference condition

NOTE: The period of measurement shall be a transmit timeslot excluding the guard period.

mean power: when applied to a CDMA modulated signal this is the power (transmitted or received) in a bandwidth of at least $(1 + \alpha)$ times the chip rate of the radio access mode

NOTE: The period of measurement shall be a transmit timeslot excluding the guard period unless otherwise stated.

output power: mean power of one carrier of the base station, delivered to a load with resistance equal to the nominal load impedance of the transmitter

Rated Output Power (PRAT): mean power level per carrier that the manufacturer has declared to be available at the antenna connector

RRC filtered mean power: mean power as measured through a root raised cosine filter with roll-off factor α and a bandwidth equal to the chip rate of the radio access mode

T: appropriate frequency in the Top of the operating frequency band of the BS: "RF channel"

wide area base stations: base station, characterized by requirements derived from macrocell and microcell scenarios with BS to UE coupling losses equal to 70 dB and 53 dB

3.2 Symbols

For the purposes of the present document, the following symbols apply:

$$\frac{\alpha}{DPCH_o - E_c} I_{or}$$

roll-off factor, $\alpha = 0,22$

The ratio of the average transmits energy per PN chip for the DPCH_o to the total transmit power spectral density in one time slot.

3.3 Abbreviations

For the purposes of the present document, the following abbreviations apply:

16QAM	16 - Quadrature Amplitude Modulation
3GPP	3 rd Generation Partnership Project
ACLR	Adjacent Channel Leakage power Ratio
ACS	Adjacent Channel Selectivity
BER	Bit Error Ratio
BS	Base Station
BTS	Base Transceiver Station
CDMA	Code Division Multiple Access
CW	Continuous Wave (unmodulated signal)
dB	decibel
dBm	decibel relative to 1 milliwatt
DCS	Digital Cellular System
DL	Down Link (forward link)
DPCH	Dedicated Physical CHannel
EMC	ElectroMagnetic Compatibility
EUT	Equipment Under Test
F	Frequency (of the assigned channel frequency of the wanted signal)
FDD	Frequency Division Duplexing
GSM	Global System for Mobile
HS-PDSCH	High Speed Physical Downlink Shared Channel
IMT-2000	International Mobile Telecommunications 2000
LV	Low Voltage
MS	Mobile station
P	output Power
Pmax	Maximum output power of the base station
PRAT	RATed Output Power of the base station
R&TTE	Radio equipment and Telecommunications Terminal Equipment
RMS	Root-Mean Square
RRC	Root-Raised Cosine
SCH	Synchronization CHannel
TDD	Time Division Duplexing
TS	Time Slot
TTE	Telecommunications Terminals Equipment
UE	User Equipment
UL	Up Link (reverse link)
UTRA	Universal Terrestrial Radio Access
WCDMA	Wideband Code Division Multiple Access

4 Technical requirements specifications

4.1 Environmental profile

The technical requirements of the present document apply under the environmental profile for operation of the equipment, which shall be declared by the supplier. The equipment shall comply with all the technical requirements of the present document at all times when operating within the boundary limits of the required operational environmental profile.

For guidance on how a supplier can declare the environmental profile see annex C.

4.2 Conformance requirements

4.2.1 Introduction

To meet the essential requirement under article 3.2 of the R&TTE Directive [1] for IMT-2000 base stations (BS) seven essential parameters in addition to those in EN 301 908-1 [7] have been identified. Table 2 provides a cross reference between these seven essential parameters and the corresponding nine technical requirements for equipment within the scope of the present document.

To fulfil an essential parameter the compliance with all the corresponding technical requirements in table 2 must be verified.

Table 2: Cross references

Essential parameter	Corresponding technical requirements
Spectrum emissions mask	4.2.2 Spectrum emission mask
	4.2.3 Transmitter Adjacent Channel Leakage power Ratio (ACLR)
Conducted spurious emissions from the transmitter antenna connector	4.2.4 Transmitter spurious emissions
Accuracy of maximum output power	4.2.5 Base station maximum output power
Intermodulation attenuation of the transmitter	4.2.6 Transmit intermodulation
Conducted spurious emissions from the receiver antenna connector	4.2.7 Receiver spurious emissions
Impact of interference on receiver performance	4.2.8 Receiver blocking characteristics
	4.2.9 Receiver intermodulation characteristics
Receiver adjacent channel selectivity	4.2.10 Receiver Adjacent Channel Selectivity (ACS)

The technical requirements also apply to the BS configurations described in annex B.

4.2.2 Spectrum emission mask

4.2.2.1 Definition

Spectrum emission mask defines an out of band emission requirement for the base station transmitter. These out of band emissions are unwanted emissions outside the channel bandwidth resulting from the modulation process and non-linearity in the transmitter but excluding spurious emissions.

4.2.2.1.1 3,84 Mcps TDD option

The spectrum emission mask specifies the limit of the transmitter out of band emissions at frequency offsets from the assigned channel frequency of the wanted signal between 2,5 MHz and 12,5 MHz.

4.2.2.1.2 1,28 Mcps TDD option

The spectrum emission mask specifies the limit of the transmitter out of band emissions at frequency offsets from the assigned channel frequency of the wanted signal between 0,8 MHz and 4 MHz.

4.2.2.2 Limits

4.2.2.2.1 3,84 Mcps TDD option

The requirement shall apply to both Wide Area BS and Local Area BS. The requirement shall be met by a base station transmitting on a single RF carrier configured in accordance with the manufacturer's specification. Emissions shall not exceed the maximum level specified in tables 3 to 6 in the frequency range of f_{offset} from 2515 MHz to f_{offset} from the carrier frequency, where:

- f_{offset} is the separation between the carrier frequency and the centre frequency of the measuring filter;
- $f_{\text{offset}_{\text{max}}}$ is either 12,5 MHz or the offset to the UMTS Tx band edge (DL transmission in the following bands: 1900 MHz to 1920 MHz, 2010 MHz to 2025 MHz and 2570 MHz to 2620 MHz), whichever is the greater.

The spectrum emissions measured according to clause 5.3.1.1.2 shall not exceed the maximum level specified in tables 3 to 6 for the appropriate BS maximum output power.

Table 3: Test requirements for spectrum emission mask values, BS maximum output power $P \geq 43$ dBm (3,84 Mcps TDD option)

Frequency offset of measurement filter centre frequency, f_{offset}	Maximum level	Measurement bandwidth
$2515 \text{ MHz} \leq f_{\text{offset}} < 2715 \text{ MHz}$	-12,5 dBm	30 kHz
$2715 \text{ MHz} \leq f_{\text{offset}} < 3515 \text{ MHz}$	$-12,5 \text{ dBm} - 15 \left(\frac{f_{\text{offset}}}{\text{MHz}} - 2,715 \right) \text{ dB}$	30 kHz
$3515 \text{ MHz} \leq f_{\text{offset}} < 4,0 \text{ MHz}$	-24,5 dBm	30 kHz
$4,0 \text{ MHz} \leq f_{\text{offset}} < 8,0 \text{ MHz}$	-11,5 dBm	1 MHz
$8,0 \text{ MHz} \leq f_{\text{offset}} < f_{\text{offset}_{\text{max}}}$	-11,5 dBm	1 MHz

Table 4: Test requirements for spectrum emission mask values, BS maximum output power $39 \text{ dBm} \leq P < 43 \text{ dBm}$ (3,84 Mcps TDD option)

Frequency offset of measurement filter centre frequency, f_{offset}	Maximum level	Measurement bandwidth
$2515 \text{ MHz} \leq f_{\text{offset}} < 2715 \text{ MHz}$	-12,5 dBm	30 kHz
$2715 \text{ MHz} \leq f_{\text{offset}} < 3515 \text{ MHz}$	$-12,5 \text{ dBm} - 15 \left(\frac{f_{\text{offset}}}{\text{MHz}} - 2,715 \right) \text{ dB}$	30 kHz
$3515 \text{ MHz} \leq f_{\text{offset}} < 4,0 \text{ MHz}$	-24,5 dBm	30 kHz
$4,0 \text{ MHz} \leq f_{\text{offset}} < 8,0 \text{ MHz}$	-11,5 dBm	1 MHz
$8,0 \text{ MHz} \leq f_{\text{offset}} < f_{\text{offset}_{\text{max}}}$	$P - 54,5 \text{ dBm}$	1 MHz

**Table 5: Test requirements for spectrum emission mask values,
BS maximum output power $31 \text{ dBm} \leq P < 39 \text{ dBm}$ (3,84 Mcps TDD option)**

Frequency offset of measurement filter centre frequency, f_{offset}	Maximum level	Measurement bandwidth
$2515 \text{ MHz} \leq f_{\text{offset}} < 2715 \text{ MHz}$	$P - 51,5 \text{ dBm}$	30 kHz
$2715 \text{ MHz} \leq f_{\text{offset}} < 3515 \text{ MHz}$	$P - 51,5 \text{ dB} - 15 \left(\frac{f_{\text{offset}}}{\text{MHz}} - 2,715 \right) \text{ dB}$	30 kHz
$3515 \text{ MHz} \leq f_{\text{offset}} < 4,0 \text{ MHz}$	$P - 63,5 \text{ dBm}$	30 kHz
$4,0 \text{ MHz} \leq f_{\text{offset}} < 8,0 \text{ MHz}$	$P - 50,5 \text{ dBm}$	1 MHz
$8,0 \text{ MHz} \leq f_{\text{offset}} < f_{\text{offset}_{\text{max}}}$	$P - 54,5 \text{ dBm}$	1 MHz

**Table 6: Test requirements for spectrum emission mask values,
BS rated output power $\text{PRAT} < 31 \text{ dBm}$ (3,84 Mcps TDD option)**

Frequency offset of measurement filter centre frequency, f_{offset}	Maximum level	Measurement bandwidth
$2515 \text{ MHz} \leq f_{\text{offset}} < 2715 \text{ MHz}$	-20,5 dBm	30 kHz
$2715 \text{ MHz} \leq f_{\text{offset}} < 3515 \text{ MHz}$	$-20,5 \text{ dBm} - 15 \left(\frac{f_{\text{offset}}}{\text{MHz}} - 2,715 \right) \text{ dB}$	30 kHz
$3515 \text{ MHz} \leq f_{\text{offset}} < 4,0 \text{ MHz}$	-32,5 dBm	30 kHz
$4,0 \text{ MHz} \leq f_{\text{offset}} < 8,0 \text{ MHz}$	-19,5 dBm	1 MHz
$8,0 \text{ MHz} \leq f_{\text{offset}} < f_{\text{offset}_{\text{max}}}$	-23,5 dBm	1 MHz

4.2.2.2.2 1,28 Mcps TDD option

The requirement shall apply to both Wide Area BS and Local Area BS. The requirement shall be met by a base station transmitting on a single RF carrier configured in accordance with the manufacturer's specification. Emissions shall not exceed the maximum level specified in tables 6a to 6c in the frequency range of f_{offset} from 0,815 MHz to f_{offset} from the carrier frequency, where:

- f_{offset} is the separation between the carrier frequency and the centre frequency of the measuring filter;
- $f_{\text{offset}_{\text{max}}}$ is either 4,0 MHz or the offset to the UMTS Tx band edge (DL transmission in the following bands: 1900 MHz to 1920 MHz, 2010 MHz to 2025 MHz and 2570 MHz to 2620 MHz), whichever is the greater.

The spectrum emissions measured according to clause 5.3.1.1.2 shall not exceed the maximum level specified in tables 6a to 6c for the appropriate BS maximum output power.

**Table 6a: Test Requirements for spectrum emission mask values,
BS maximum output power $P \geq 34 \text{ dBm}$ (1,28 Mcps TDD option)**

Frequency offset of measurement filter centre frequency, f_{offset}	Maximum level	Measurement bandwidth
$0,815 \text{ MHz} \leq f_{\text{offset}} < 1015 \text{ MHz}$	-18,5 dBm	30 kHz
$1015 \text{ MHz} \leq f_{\text{offset}} < 1815 \text{ MHz}$	$-18,5 \text{ dBm} - 10 \left(\frac{f_{\text{offset}}}{\text{MHz}} - 1,015 \right) \text{ dB}$	30 kHz
$1815 \text{ MHz} \leq f_{\text{offset}} < 2,3 \text{ MHz}$	-26,5 dBm	30 kHz
$2,3 \text{ MHz} \leq f_{\text{offset}} < f_{\text{offset}}$	-11,5 dBm	1 MHz

**Table 6b: Test Requirements for spectrum emission mask values,
BS maximum output power $26 \text{ dBm} \leq P < 34 \text{ dBm}$ (1,28 Mcps TDD option)**

Frequency offset of measurement filter centre frequency, f_{offset}	Maximum level	Measurement bandwidth
$0,815 \text{ MHz} \leq f_{\text{offset}} < 1\,015 \text{ MHz}$	$P - 52,5 \text{ dB}$	30 kHz
$1015 \text{ MHz} \leq f_{\text{offset}} < 1815 \text{ MHz}$	$P - 52,5 \text{ dB} - 10 \left(\frac{f_{\text{offset}}}{\text{MHz}} - 1,015 \right) \text{ dB}$	30 kHz
$1815 \text{ MHz} \leq f_{\text{offset}} < 2,3 \text{ MHz}$	$P - 60,5 \text{ dB}$	30 kHz
$2,3 \text{ MHz} \leq f_{\text{offset}} < f_{\text{offset}}$	$P - 45,5 \text{ dB}$	1 MHz

**Table 6c: Test Requirements for spectrum emission mask values,
BS maximum output power $P < 26 \text{ dBm}$ (1,28 Mcps TDD option)**

Frequency offset of measurement filter centre frequency, f_{offset}	Maximum level	Measurement bandwidth
$0,815 \text{ MHz} \leq f_{\text{offset}} < 1015 \text{ MHz}$	$-26,5 \text{ dBm}$	30 kHz
$1015 \text{ MHz} \leq f_{\text{offset}} < 1815 \text{ MHz}$	$-26,5 \text{ dBm} - 10 \left(\frac{f_{\text{offset}}}{\text{MHz}} - 1,015 \right) \text{ dB}$	30 kHz
$1815 \text{ MHz} \leq f_{\text{offset}} < 2,3 \text{ MHz}$	$-34,5 \text{ dBm}$	30 kHz
$2,3 \text{ MHz} \leq f_{\text{offset}} < f_{\text{offset}}$	$-19,5 \text{ dBm}$	1 MHz

4.2.2.3 Conformance

Conformance tests described in clause 5.3.1 shall be carried out.

4.2.3 Transmitter adjacent channel leakage power ratio

4.2.3.1 Definition

Transmitter adjacent Channel Leakage power Ratio (ACLR) is the ratio of the RRC filtered mean power centred on the assigned channel frequency to the RRC filtered mean power centred on an adjacent channel frequency. (ACLR is also an "out of band emission" requirement, see clause 4.2.2.) The requirements shall apply for all configurations of BS (single carrier or multi-carrier), and for all operating modes foreseen by the manufacturer's specification.

In some cases the requirement is expressed as adjacent channel leakage power, which is the RRC filtered mean power for the given bandwidth of the victim system at the defined adjacent channel offset.

4.2.3.2 Limits

4.2.3.2.1 General requirements

4.2.3.2.1.1 3,84 Mcps TDD option

The requirement shall apply to both Wide Area BS and Local Area BS. The ACLR of a single carrier BS or a multi-carrier BS with contiguous carrier frequencies shall be equal to or greater than the limits given in table 7.

Table 7: BS ACLR limits (3,84 Mcps TDD option)

BS adjacent channel offset below the first or above the last carrier frequency used	ACLR limit
$\pm 5 \text{ MHz}$	44,2 dB
$\pm 10 \text{ MHz}$	54,2 dB

If a BS provides multiple non-contiguous single carriers or multiple non-contiguous groups of contiguous single carriers, the above requirements shall be applied individually to the single carriers or group of single carriers.

4.2.3.2.1.2 1,28 Mcps TDD option

The requirement shall apply to both Wide Area BS and Local Area BS. The ACLR of a single carrier BS or a multi-carrier BS with contiguous carrier frequencies shall be equal to or greater than the limits given in table 7a.

Table 7a: BS ACLR limits (1,28 Mcps TDD option)

BS adjacent channel offset below the first or above the last carrier frequency used	ACLR limit
±1,6 MHz	39,2 dB
±3,2 MHz	44,2 dB

If a BS provides multiple non-contiguous single carriers or multiple non-contiguous groups of contiguous single carriers, the above requirements shall be applied individually to the single carriers or group of single carriers.

4.2.3.2.2 Co-existence with UTRA-FDD

4.2.3.2.2.1 3,84 Mcps TDD option

The requirement shall be applied for protection of UTRA FDD operating on the first or second adjacent channel. Different requirements shall apply to Wide Area BS and Local Area BS. The adjacent channel leakage power shall not exceed the limits specified in table 7b.

Table 7b: Adjacent channel leakage power limits for protection of UTRA-FDD on adjacent channels (3,84 Mcps TDD option)

Frequency Range for ACLR Measurement	BS class	BS adjacent channel offset	Maximum level	Measurement bandwidth
1920 MHz to 1930 MHz, 2560 MHz to 2570 MHz, 2620 MHz to 2630 MHz	Wide Area BS	±5 MHz	-36 dBm	3,84 MHz
	Wide Area BS	±10 MHz	-32 dBm	3,84 MHz
	Local Area BS	±5 MHz	-22,2 dBm	3,84 MHz
	Local Area BS	±10 MHz	-32,2 dBm	3,84 MHz

If a BS provides multiple non-contiguous single carriers or multiple non-contiguous groups of contiguous single carriers, the above requirements shall be applied to those adjacent channels of the single carriers or group of single channels.

4.2.3.2.2.2 1,28 Mcps TDD option

The requirement shall be applied for protection of UTRA FDD operating on the first or second adjacent channel. This requirement is only applicable if the equipment is intended to operate at the highest carrier frequency in the range 1916,2 MHz to 1920 MHz in uncoordinated networks. Different requirements shall apply to Wide Area BS and Local Area BS. The adjacent channel leakage power shall not exceed the limits specified in table 7c.

Table 7c: Adjacent channel leakage power limits for protection of UTRA-FDD on adjacent channels (1,28 Mcps TDD option)

BS class	Centre frequency for measurement	Maximum level	Measurement bandwidth
Wide Area BS	1922,6 MHz	-32 dBm	3,84 MHz
Local Area BS	1922,6 MHz	-22,2 dBm	3,84 MHz

4.2.3.2.3 Co-existence with unsynchronized UTRA TDD on adjacent channels

4.2.3.2.3.1 3,84 Mcps TDD option

The requirement shall be applied for protection of unsynchronized UTRA TDD operating on the first or second adjacent channel. Different requirements shall apply to Wide Area BS and Local Area BS. The adjacent channel leakage power shall not exceed the limits specified in table 7d.

Table 7d: Adjacent channel leakage power limits for protection of unsynchronized UTRA-TDD on adjacent channels (3,84 Mcps TDD option)

BS Class	BS adjacent channel offset below the first or above the last carrier frequency used	Maximum Level	Measurement Bandwidth
Wide Area BS	5 MHz	-25 dBm	3,84 MHz
Wide Area BS	10 MHz	-25 dBm	3,84 MHz
Local Area BS	5 MHz	-15,2 dBm	3,84 MHz
Local Area BS	10 MHz	-25,2 dBm	3,84 MHz

If a BS provides multiple non-contiguous single carriers or multiple non-contiguous groups of contiguous single carriers, the above requirements shall be applied to those adjacent channels of the single carriers or group of single channels.

4.2.3.2.3.2 1,28 Mcps TDD option

The requirement shall be applied for protection of unsynchronized UTRA TDD operating on the first or second adjacent channel. Different requirements shall apply to Wide Area BS and Local Area BS. The adjacent channel leakage power shall not exceed the limits specified in table 7e.

Table 7e: Adjacent channel leakage power limits for protection of unsynchronized UTRA-TDD on adjacent channels (1,28 Mcps TDD option)

BS Class	BS Adjacent Channel Offset	Maximum Level	Measurement Bandwidth
Wide Area BS	$\pm 1,6$ MHz	-28 dBm	1,28 MHz
Wide Area BS	$\pm 3,2$ MHz	-28 dBm	1,28 MHz
Wide Area BS	$\pm 3,4$ MHz	-28 dBm	3,84 MHz
Local Area BS	$\pm 1,6$ MHz	-15,2 dBm	1,28 MHz
Local Area BS	$\pm 3,2$ MHz	-15,2 dBm	1,28 MHz
Local Area BS	$\pm 3,4$ MHz	-15,2 dBm	3,84 MHz

If a BS provides multiple non-contiguous single carriers or multiple non-contiguous groups of contiguous single carriers, the above requirements shall be applied to those adjacent channels of the single carriers or group of single channels.

4.2.3.3 Conformance

Conformance tests described in clause 5.3.2 shall be carried out.

4.2.4 Transmitter spurious emissions

4.2.4.1 Definition

Transmitter spurious emissions are emissions which are caused by unwanted transmitter effects such as harmonics emission, parasitic emission, intermodulation products and frequency conversion products, but exclude out of band emissions. This is measured at the base station RF output port.

Unless otherwise stated, all requirements are measured as mean power.

4.2.4.2 Limits

4.2.4.2.1 General requirements

The requirements shall apply to both Wide Area BS and Local Area BS.

4.2.4.2.1.1 3,84 Mcps TDD option

The requirements of table 8 shall apply whatever the type of transmitter considered (single carrier or multi-carrier). It applies for all transmission modes foreseen by the manufacturer.

These requirements apply at frequencies within the specified frequency ranges which are more than 12,5 MHz under the first carrier frequency used or more than 12,5 MHz above the last carrier frequency used.

The power of any spurious emission shall not exceed the maximum levels given in table 8.

Table 8: BS Mandatory spurious emissions limits (3,84 Mcps TDD option)

Band	Maximum level	Measurement bandwidth	Note
9 kHz to 150 kHz	-36 dBm	1 kHz	see note 1
150 kHz to 30 MHz	-36 dBm	10 kHz	see note 1
30 MHz to 1 GHz	-36 dBm	100 kHz	see note 1
1 GHz to Fc1 - 60 MHz or FI - 10 MHz <i>whichever is the higher</i>	-30 dBm	1 MHz	see note 1
Fc1 - 60 MHz or FI - 10 MHz <i>whichever is the higher</i> -	-25 dBm	1 MHz	see note 2
Fc1 - 50 MHz or FI - 10 MHz <i>whichever is the higher</i>	-15 dBm	1 MHz	see note 2
Fc1 - 50 MHz or FI - 10 MHz <i>whichever is the higher</i> -	-25 dBm	1 MHz	see note 2
Fc2 + 50 MHz or Fu + 10 MHz <i>whichever is the lower</i>	-30 dBm	1 MHz	see notes 1 and 3
Fc2 + 50 MHz or Fu + 10 MHz <i>whichever is the lower</i> -	-25 dBm	1 MHz	see note 2
Fc2 + 60 MHz or Fu + 10 MHz <i>whichever is the lower</i>	-30 dBm	1 MHz	see notes 1 and 3
Fc2 + 60 MHz or Fu + 10 MHz <i>whichever is the lower</i> -	-30 dBm	1 MHz	see notes 1 and 3
12,75 GHz			

NOTE 1: Bandwidth as in ITU-R Recommendation SM.329-10 [5], clause 4.1.
 NOTE 2: Specification in accordance with ITU-R Recommendation SM.329-10 [5], clause 4.3 and annex 7.
 NOTE 3: Upper frequency as in ITU-R Recommendation SM.329-10 [5], clause 2.5, table 1.

Fc1: Centre frequency of emission of the first carrier transmitted by the BS.
 Fc2: Centre frequency of emission of the last carrier transmitted by the BS.
 FI: Lower frequency of the band in which TDD operates.
 Fu: Upper frequency of the band in which TDD operates.

4.2.4.2.1.2 1,28 Mcps TDD option

The requirements of table 8a shall apply whatever the type of transmitter considered (single carrier or multi-carrier). It applies for all transmission modes foreseen by the manufacturer.

These requirements apply at frequencies within the specified frequency ranges which are more than 4 MHz under the first carrier frequency used or more than 4 MHz above the last carrier frequency used.

The power of any spurious emission shall not exceed the maximum levels given in table 8a.

Table 8a: BS mandatory spurious emissions limits (1,28 Mcps TDD option)

Band	Maximum level	Measurement bandwidth	Note
9 kHz to 150 kHz	-36 dBm	1 kHz	see note 1
150 kHz to 30 MHz	-36 dBm	10 kHz	see note 1
30 MHz to 1 GHz	-36 dBm	100 kHz	see note 1
1 GHz to Fc1 - 19,2 MHz or FI - 10 MHz <i>whichever is the higher</i>	-30 dBm	1 MHz	see note 1
Fc1 - 19,2 MHz or FI - 10 MHz <i>whichever is the higher</i> - Fc1 - 16 MHz or FI - 10 MHz <i>whichever is the higher</i>	-25 dBm	1 MHz	see note 2
Fc1 - 16 MHz or FI - 10 MHz <i>whichever is the higher</i> - Fc2 + 16 MHz or Fu + 10 MHz <i>whichever is the lower</i>	-15 dBm	1 MHz	see note 2
Fc2 + 16 MHz or Fu + 10 MHz <i>whichever is the lower</i> - Fc2 + 19,2 MHz or Fu + 10 MHz <i>whichever is the lower</i>	-25 dBm	1 MHz	see note 2
Fc2 + 19,2 MHz or Fu + 10 MHz <i>whichever is the lower</i> - 12,75 GHz	-30 dBm	1 MHz	see notes 1 and 3
NOTE 1: Bandwidth as in ITU-R Recommendation SM.329-10 [5], clause 4.1.			
NOTE 2: Specification in accordance with ITU-R Recommendation SM.329-10 [5], clause 4.3 and annex 7.			
NOTE 3: Upper frequency as in ITU-R Recommendation SM.329-10 [5], clause 2.5, table 1.			
Fc1: Centre frequency of emission of the first carrier transmitted by the BS.			
Fc2: Centre frequency of emission of the last carrier transmitted by the BS.			
FI: Lower frequency of the band in which TDD operates.			
Fu: Upper frequency of the band in which TDD operates.			

4.2.4.2.2 Co-existence with GSM 900

This requirement shall be applied for the protection of GSM 900 MS and GSM 900 BTS receivers. The requirement shall apply to both Wide Area BS and Local Area BS. The power of any spurious emission shall not exceed the maximum levels given in table 9.

Table 9: BS spurious emissions limits for protection of GSM 900 MS and GSM 900 BTS receiver

Band	Maximum level	Measurement bandwidth
876 MHz to 915 MHz	-61 dBm	100 kHz
921 MHz to 960 MHz	-57 dBm	100 kHz

4.2.4.2.3 Co-existence with DCS 1800

This requirement shall be applied for the protection of DCS 1800 MS and DCS 1800 BTS receivers. The requirement shall apply to both Wide Area BS and Local Area BS. The power of any spurious emission shall not exceed the maximum levels given in table 10.

Table 10: BS spurious emissions limits for protection of DCS 1800 MS and DCS 1800 BTS receiver

Band	Maximum level	Measurement bandwidth
1710 MHz to 1785 MHz	-61 dBm	100 kHz
1805 MHz to 1880 MHz	-47 dBm	100 kHz

4.2.4.2.4 Co-existence with UTRA FDD

This requirement shall be applied for protection of UTRA FDD. Different requirements shall apply to Wide Area BS and Local Area BS. For TDD base stations which use carrier frequencies within the band 2010 MHz to 2025 MHz the requirements applies at all frequencies within the specified frequency bands in table 11. For 3,84 Mcps TDD option base stations which use a carrier frequency within the band from 1900 MHz to 1920 MHz, the requirement applies at frequencies within the specified frequency range which are more than 12,5 MHz above the last carrier used in the frequency band from 1900 MHz to 1920 MHz. For 1,28 Mcps TDD option base stations which use carrier frequencies within the band from 1900 MHz to 1920 MHz, the requirement applies at frequencies within the specified frequency range which are more than 4 MHz above the last carrier used in the frequency band from 1900 MHz to 1920 MHz. The power of any spurious emission shall not exceed the maximum levels given in table 11.

Table 11: BS spurious emissions limits for protection of UTRA FDD receiver

BS class	Band	Maximum level	Measurement bandwidth	Note
Wide Area BS	1920 MHz to 1980 MHz	-43 dBm	3,84 MHz	Note 1
Wide Area BS	2110 MHz to 2170 MHz	-52 dBm	1 MHz	
Wide Area BS	2500 MHz to 2570 MHz	-43 dBm	3,84 MHz	Note 2
Wide Area BS	2620 MHz to 2690 MHz	-52 dBm	1 MHz	
Local Area BS	1920 MHz to 1980 MHz	-40 dBm	3,84 MHz	Note 1
Local Area BS	2110 MHz to 2170 MHz	-52 dBm	1 MHz	
Local Area BS	2500 MHz to 2570 MHz	-40 dBm	3,84 MHz	Note 2
Local Area BS	2620 MHz to 2690 MHz	-52 dBm	1 MHz	

NOTE 1: For 3,84 Mcps TDD option base stations which use carrier frequencies within the band 1900 – 1920 MHz, the requirement shall be measured RRC filtered mean power with the lowest centre frequency of measurement at 1922,6 MHz or 15 MHz above the last TDD carrier used, whichever is higher. For 1,28 Mcps TDD option base stations which use carrier frequencies within the band 1900 – 1920 MHz, the requirement shall be measured RRC filtered mean power with the lowest centre frequency of measurement at 1922,6 MHz or 6,6 MHz above the last TDD carrier used, whichever is higher.

NOTE 2: For 3,84 Mcps TDD option base stations which use carrier frequencies within the band 2570 – 2620 MHz, the requirement shall be measured RRC filtered mean power with the lowest centre frequency of measurement at 2567,5 MHz or 15 MHz below the last TDD carrier used, whichever is lower. For 1,28 Mcps TDD option base stations which use carrier frequencies within the band 2570 – 2620 MHz, the requirement shall be measured RRC filtered mean power with the lowest centre frequency of measurement at 2567,5 MHz or 6,6 MHz below the last TDD carrier used, whichever is lower.

4.2.4.2.5 Co-existence with unsynchronized TDD

This requirement shall be applied for protection of unsynchronized UTRA TDD. Different requirements shall apply to Wide Area BS and Local Area BS. The RRC filtered mean power of any spurious emission shall not exceed the maximum levels given in table 11a

Table 11a: BS spurious emissions limits for protection of unsynchronized TDD

BS Class	Band	Maximum level	Measurement bandwidth
Wide Area BS	1900 MHz to 1920 MHz	-39 dBm	3,84 MHz
Wide Area BS	2010 MHz to 2025 MHz	-39 dBm	3,84 MHz
Wide Area BS	2570 MHz to 2620 MHz	-39 dBm	3,84 MHz
Local Area BS	1900 MHz to 1920 MHz	-36 dBm	3,84 MHz
Local Area BS	2010 MHz to 2025 MHz	-36 dBm	3,84 MHz
Local Area BS	2570 MHz to 2620 MHz	-36 dBm	3,84 MHz

4.2.4.3 Conformance

Conformance tests described in clause 5.3.3 shall be carried out.

4.2.5 Base station maximum output power

4.2.5.1 Definition

The "base station maximum output power" (P_{max}) requirement is defined relative to the "rated output power". Maximum output power (P_{max}) and rated output power (PRAT) are defined in clause 3.1.

4.2.5.2 Limits

The requirement shall apply to both Wide Area BS and Local Area BS.

In normal conditions, the measured output power, derived according to clause 5.3.4.1.2, shall remain within +2,7 dB and -2,7 dB of the manufacturer's rated output power.

In extreme conditions, the measured output power, derived according to clause 5.3.4.1.2, shall remain within +3,2 dB and -3,2 dB of the manufacturer's rated output power.

4.2.5.3 Conformance

Conformance tests described in clause 5.3.4 shall be carried out.

4.2.6 Transmit intermodulation

4.2.6.1 Definition

The transmit intermodulation performance is a measure of the capability of the transmitter to inhibit the generation of signals in its non linear elements caused by presence of the wanted signal and an interfering signal reaching the transmitter via the antenna.

4.2.6.2 Limits

4.2.6.2.1 3,84 Mcps TDD option

The transmit intermodulation level is the power of the intermodulation products when a WCDMA modulated interference signal is injected into the antenna connector at a level of 30 dB lower than that of the subject signal. The requirements are applicable for a single carrier. The frequency of the interference signal shall be ± 5 MHz, ± 10 MHz and ± 15 MHz offset from the subject signal but excluding interference carrier frequencies outside of the frequency bands 1 900 MHz to 1 920 MHz, 2 010 MHz to 2 025 MHz and 2 570 MHz to 2620 MHz.

The requirement shall apply to both Wide Area BS and Local Area BS.

The transmit intermodulation level shall not exceed the spectrum emission mask requirements, the transmitter adjacent channel leakage power ratio requirement and the transmitter spurious emission requirements, described in clauses 4.2.2.2.1, 4.2.3.2.1, 4.2.4.2.1.1, 4.2.4.2.2 to 4.2.4.2.4 respectively.

4.2.6.2.2 1,28 Mcps TDD option

The transmit intermodulation level is the power of the intermodulation products when a CDMA modulated interference signal is injected into the antenna connector at a level of 30 dB lower than that of the subject signal. The requirements are applicable for a single carrier. The frequency of the interference signal shall be $\pm 1,6$ MHz, $\pm 3,2$ MHz and $\pm 4,8$ MHz offset from the subject signal but excluding interference carrier frequencies outside of the frequency bands 1900 MHz to 1920 MHz, 2010 MHz to 2 025 MHz and 2570 MHz to 2620 MHz.

The requirement shall apply to both Wide Area BS and Local Area BS.

The transmit intermodulation level shall not exceed the spectrum emission mask requirements, the transmitter adjacent channel leakage power ratio requirement and the transmitter spurious emission requirements, described in clauses 4.2.2.2.2, 4.2.3.2.2, 4.2.4.2.1.2, 4.2.4.2.2, 4.2.4.2.3 and 4.2.4.2.4 respectively.

4.2.6.3 Conformance

Conformance tests described in clause 5.3.5 shall be carried out.

4.2.7 Receiver spurious emissions

4.2.7.1 Definition

The spurious emissions power is the power of emissions generated or amplified in a receiver that appear at the BS antenna connector. The requirements apply to all BS with separate RX and TX antenna port. The test shall be performed when both TX and RX are on with the TX port terminated.

For BS equipped with only a single antenna connector for both transmitter and receiver, the requirements of clause 4.2.4 Transmitter spurious emissions shall apply to this port, and this test need not be performed.

4.2.7.2 Limits

The requirement shall apply to both Wide Area BS and Local Area BS.

4.2.7.2.1 3,84 Mcps TDD option

The power of any spurious emission shall not exceed the values given in table 12.

Table 12: Receiver spurious emission requirements (3,84 Mcps TDD option)

Band	Maximum level	Measurement bandwidth	Note
30 MHz to 1 GHz	-57 dBm	100 kHz	-
1 GHz to 1,9 GHz	-47 dBm	1 MHz	see note
1900 GHz to 1980 GHz	-78 dBm	3,84 MHz	see note
1980 GHz to 2010 GHz	-47 dBm	1 MHz	see note
2010 GHz to 2025 GHz	-78 dBm	3,84 MHz	see note
2025 GHz to 2500 GHz	-47 dbm	1 MHz	see note
2500 GHz to 2620 GHz	-78 dBm	3,84 MHz	see note
2620 GHz to 12,75 GHz	-47 dBm	1 MHz	see note

NOTE: With the exception of frequencies between 12,5 MHz below the first carrier frequency and 12,5 MHz above the last carrier frequency used by the BS.

4.2.7.2.2 1,28 Mcps TDD option

The power of any spurious emission shall not exceed the values given in table 12a.

Table 12a: Receiver spurious emission requirements (1,28 Mcps TDD option)

Band	Maximum level	Measurement Bandwidth	Note
30 MHz to 1 GHz	-57 dBm	100 kHz	-
1 GHz to 1,9 GHz	-47 dBm	1 MHz	see note
1900 GHz to 1980 GHz	-83 dBm	1,28 MHz	see note
1980 GHz to 2010 GHz	-47 dBm	1 MHz	see note
2010 GHz to 2025 GHz	-83 dBm	1,28 MHz	see note
2025 GHz to 2500 GHz	-47 dbm	1 MHz	see note
2500 GHz to 2620 GHz	-83 dBm	1,28 MHz	see note
2620 GHz to 12,75 GHz	-47 dBm	1 MHz	see note

NOTE: With the exception of frequencies between 4 MHz below the first carrier frequency and 4 MHz above the last carrier frequency used by the BS.

4.2.7.3 Conformance

Conformance tests described in clause 5.3.6 shall be carried out.

4.2.8 Receiver blocking characteristics

4.2.8.1 Definition

The blocking characteristics are a measure of the receiver ability to receive a wanted signal at its assigned channel frequency in the presence of an unwanted interferer on frequencies other than those of the adjacent channels.

4.2.8.2 Limits

4.2.8.2.1 3,84 Mcps TDD option

Different requirements shall apply to Wide Area BS and Local Area BS. The blocking requirements apply to interfering signals with centre frequency within the ranges specified in table 13 (for operating band a) and table 13a(1) (for operating band d) for the Wide Area BS and table 13a (for operating band a) and table 13a(2) (for operating band d) for the Local Area BS respectively, using a 1 MHz step size.

Using the UL reference measurement channel (12,2 kbit/s) defined in TS 125 105 [3], annex A the BER of this wanted signal shall not exceed 0,001 in the presence of an interfering signal. This static reference performance shall be met with a wanted and an interfering signal coupled to the BS antenna input using the parameters specified in table 13 (for operating band a) and table 13a(1) (for operating band d) for the Wide Area BS and table 13a (for operating band d) and table 13a(2) (for operating band d) for the Local Area BS respectively.

Table 13: Blocking requirements for Wide Area BS (3,84 Mcps TDD option) for operating band a

Centre frequency of interfering signal	Interfering signal mean power	Wanted signal mean power	Minimum offset of interfering signal	Type of interfering signal
1900 MHz to 1920 MHz, 2010 MHz to 2025 MHz	-40 dBm	-103 dBm	10 MHz	WCDMA signal with one code
1880 MHz to 1900 MHz, 1990 MHz to 2010 MHz, 2025 MHz to 2045 MHz	-40 dBm	-103 dBm	10 MHz	WCDMA signal with one code
1920 MHz to 1980 MHz	-40 dBm	-103 dBm	10 MHz	WCDMA signal with one code
1 MHz to 1880 MHz, 1980 MHz to 1990 MHz, 2045 MHz to 12750 MHz	-15 dBm	-103 dBm	-	CW carrier

Table 13a: Blocking requirements for Local Area BS (3,84 Mcps TDD option) for operating band a

Centre frequency of interfering signal	Interfering signal mean power	Wanted signal mean power	Minimum offset of interfering signal	Type of interfering signal
1900 MHz to 1920 MHz, 2010 MHz to 2025 MHz	-30 dBm	-89 dBm	10 MHz	WCDMA signal with one code
1880 MHz to 1900 MHz, 1990 MHz to 2010 MHz, 2025 MHz to 2045 MHz	-30 dBm	-89 dBm	10 MHz	WCDMA signal with one code
1920 MHz to 1980 MHz	-30 dBm	-89 dBm	10 MHz	WCDMA signal with one code
1 MHz to 1880 MHz, 1980 MHz to 1990 MHz, 2045 MHz to 12750 MHz	-15 dBm	-89 dBm	-	CW carrier

Table 13a(1): Blocking requirements for Wide Area BS (3,84 Mcps TDD option) for operating band d

Centre frequency of interfering signal	Interfering signal mean power	Wanted signal mean power	Minimum offset of interfering signal	Type of interfering signal
2570 MHz to 2620 MHz,	-40 dBm	-103 dBm	10 MHz	WCDMA signal with one code
2500 MHz to 2570 MHz, 2620 MHz to 2690 MHz	-40 dBm	-103 dBm	10 MHz	WCDMA signal with one code
1 MHz to 2550 MHz, 2690 MHz to 12 750 MHz	-15 dBm	-103 dBm	-	CW carrier

Table 13a(2): Blocking requirements for Local Area BS (3,84 Mcps TDD option) for operating band d

Centre frequency of interfering signal	Interfering signal mean power	Wanted signal mean power	Minimum offset of interfering signal	Type of interfering signal
2570 MHz to 2620 MHz,	-30 dBm	-89 dBm	10 MHz	WCDMA signal with one code
2500 MHz to 2570 MHz, 2620 MHz to 2690 MHz	-30 dBm	-89 dBm	10 MHz	WCDMA signal with one code
1 MHz to 2550 MHz, 2690 MHz to 12 750 MHz	-15 dBm	-89 dBm	-	CW carrier

4.2.8.2.2 1,28 Mcps TDD option

Different requirements shall apply to Wide Area BS and Local Area BS. The blocking requirements apply to interfering signals with centre frequency within the ranges specified in table 13b (for operating band a) and table 13d (for operating band d) for the Wide Area BS and table 13c (for operating band a) and table 13e (for operating band d) for the Local Area BS respectively, using a 1 MHz step size.

Using the UL reference measurement channel (12,2 kbit/s) defined in TS 125 105 [3], annex A the BER of this wanted signal shall not exceed 0,001 in the presence of an interfering signal. This static reference performance shall be met with a wanted and an interfering signal coupled to the BS antenna input using the parameters specified in table 13b (for operating band a) and table 13d (for operating band d) for the Wide Area BS and table 13c (for operating band a) and table 13e (for operating band d) for the Local Area BS respectively.

Table 13b: Blocking requirements for Wide Area BS (1,28 Mcps TDD option) for operating band a

Centre frequency of interfering signal	Interfering signal mean power	Wanted signal mean power	Minimum offset of interfering signal	Type of interfering signal
1900 MHz to 1920 MHz, 2010 MHz to 2025 MHz	-40 dBm	-104 dBm	3,2 MHz	1,28 Mcps TDD signal with one code
1880 MHz to 1900 MHz, 1990 MHz to 2010 MHz, 2025 MHz to 2045 MHz	-40 dBm	-104 dBm	3,2 MHz	1,28 Mcps TDD signal with one code
1920 MHz to 1980 MHz	-40 dBm	-104 dBm	3,2 MHz	1,28 Mcps TDD signal with one code
1 MHz to 1880 MHz, 1980 MHz to 1990 MHz, 2045 MHz to 12750 MHz	-15 dBm	-104 dBm	-	CW carrier

Table 13c: Blocking requirements for Local Area BS (1,28 Mcps TDD option) for operating band a

Centre frequency of interfering signal	Interfering signal mean power	Wanted signal mean power	Minimum offset of interfering signal	Type of interfering signal
1900 MHz to 1920 MHz, 2010 MHz to 2025 MHz	-30 dBm	-90 dBm	3,2 MHz	1,28 Mcps TDD signal with one code
1880 MHz to 1900 MHz, 1990 MHz to 2010 MHz, 2025 MHz to 2045 MHz	-30 dBm	-90 dBm	3,2 MHz	1,28 Mcps TDD signal with one code
1920 MHz to 1980 MHz	-30 dBm	-90 dBm	3,2 MHz	1,28 Mcps TDD signal with one code
1 MHz to 1880 MHz, 1980 MHz to 1990 MHz, 2045 MHz to 12750 MHz	-15 dBm	-90 dBm	-	CW carrier

Table 13d: Blocking requirements for Wide Area BS (1,28 Mcps TDD option) for operating band d

Centre frequency of interfering signal	Interfering signal mean power	Wanted signal mean power	Minimum offset of interfering signal	Type of interfering signal
2570 MHz to 2620 MHz,	-40 dBm	-104 dBm	3,2 MHz	1,28 Mcps TDD signal with one code
2500 MHz to 2570 MHz, 2 620 MHz to 2690 MHz	-40 dBm	-104 dBm	3,2 MHz	1,28 Mcps TDD signal with one code
1 MHz to 2550 MHz, 2690 MHz to 12750 MHz	-15 dBm	-104 dBm	-	CW carrier

Table 13e: Blocking requirements for Local Area BS (1,28 Mcps TDD option) for operating band d

Centre frequency of interfering signal	Interfering signal mean power	Wanted signal mean power	Minimum offset of interfering signal	Type of interfering signal
2570 MHz to 2620 MHz,	-30 dBm	-90 dBm	3,2 MHz	1,28 Mcps TDD signal with one code
2500 MHz to 2570 MHz, 2620 MHz to 2690 MHz	-30 dBm	-90 dBm	3,2 MHz	1,28 Mcps TDD signal with one code
1 MHz to 2550 MHz, 2690 MHz to 12750 MHz	-15 dBm	-90 dBm	-	CW carrier

4.2.8.3 Conformance

Conformance tests described in clause 5.3.7 shall be carried out.

4.2.9 Receiver intermodulation characteristics

4.2.9.1 Definition

Third and higher order mixing of two interfering RF signals can produce an interfering signal in the band of the desired channel. Intermodulation response rejection is a measure of the capability of the receiver to receive a wanted signal on its assigned channel frequency in the presence of two or more interfering signals which have a specific frequency relationship to the wanted signal.

4.2.9.2 Limits

4.2.9.2.1 3,84 Mcps TDD option

Different requirements shall apply to Wide Area BS and Local Area BS. Using the UL reference measurement channel (12,2 kbit/s) defined in TS 125 105 [3], annex A the BER of this wanted signal shall not exceed 0,001 in the presence of interfering signals. This static reference performance shall be met when the following signals are coupled to the BS antenna input:

- a wanted signal at the assigned channel frequency, with mean power 6 dB above the static reference level (see note);
- two interfering signals with the parameters specified in table 14.

NOTE: The static reference level is -109 dBm for the Wide Area base station and -95 dBm for the Local Area base station.

Table 14: Parameters of the interfering signals for intermodulation characteristics testing (3,84 Mcps TDD option)

Interfering Signal mean power		Offset	Type of Interfering Signal
Wide Area BS	Local Area BS		
-48 dBm	-38 dBm	10 MHz	CW signal
-48 dBm	-38 dBm	20 MHz	WCDMA signal with one code

4.2.9.2.2 1,28 Mcps TDD option

Different requirements shall apply to Wide Area BS and Local Area BS. Using the UL reference measurement channel (12,2 kbit/s) defined in TS 125 105 [3], annex A the BER of this wanted signal shall not exceed 0,001 in the presence of interfering signals. This static reference performance shall be met when the following signals are coupled to the BS antenna input:

- a wanted signal at the assigned channel frequency, with mean power 6 dB above the static reference level (see note);
- two interfering signals with the parameters specified in table 14a.

NOTE: The static reference level is -110 dBm for the Wide Area base station and -96 dBm for the Local Area base station

Table 14a: Parameters of the interfering signals for intermodulation characteristics testing (1,28 Mcps TDD option)

Interfering Signal mean power		Offset	Type of Interfering Signal
Wide Area BS	Local Area BS		
-48 dBm	-38 dBm	3,2 MHz	CW signal
-48 dBm	-38 dBm	6,4 MHz	1,28 Mcps TDD option signal with one code

4.2.9.3 Conformance

Conformance tests described in clause 5.3.8 shall be carried out.

4.2.10 Receiver adjacent channel selectivity

4.2.10.1 Definition

Adjacent channel selectivity (ACS) is a measure of the receiver ability to receive a wanted signal at its assigned channel frequency in the presence of a single code CDMA modulated adjacent channel signal at a given frequency offset from the centre frequency of the assigned channel. ACS is the ratio of the receiver filter attenuation on the assigned channel frequency to the receive filter attenuation on the adjacent channel(s).

4.2.10.2 Limits

4.2.10.2.1 3,84 Mcps TDD option

Different requirements shall apply to Wide Area BS and Local Area BS. The BER, measured on the wanted signal in the presence of an interfering signal, shall not exceed 0,001 for the parameters specified in table 15 for the Wide Area BS and table 15a for the Local Area BS respectively.

Table 15: Parameters of the wanted signal and the interfering signal for ACS testing for Wide Area BS (3,84 Mcps TDD option)

Parameter	Level	Unit
Reference measurement channel data rate	12,2	kbit/s
Wanted signal mean power	-103	dBm
Interfering signal mean power	-52	dBm
F_{uw} (modulated)	5	MHz
NOTE: F_{uw} is the frequency offset of the unwanted interfering signal from the assigned channel frequency of the wanted signal.		

Table 15a: Parameters of the wanted signal and the interfering signal for ACS testing for Local Area BS (3,84 Mcps TDD option)

Parameter	Level	Unit
Reference measurement channel data rate	12,2	kbit/s
Wanted signal mean power	-89	dBm
Interfering signal mean power	-38	dBm
F_{uw} (modulated)	5	MHz
NOTE: F_{uw} is the frequency offset of the unwanted interfering signal from the assigned channel frequency of the wanted signal.		

4.2.10.2.2 1,28 Mcps TDD option

Different requirements shall apply to Wide Area BS and Local Area BS. The BER, measured on the wanted signal in the presence of an interfering signal, shall not exceed 0,001 for the parameters specified in table 15b for the Wide Area BS and table 15c for the Local Area BS respectively.

Table 15b: Parameters of the wanted signal and the interfering signal for ACS testing for Wide Area BS (1,28 Mcps TDD option)

Parameter	Level	Unit
Reference measurement channel data rate	12,2	kbit/s
Wanted signal mean power	-104	dBm
Interfering signal mean power	-55	dBm
F_{uw} (modulated)	1,6	MHz
NOTE: F_{uw} is the frequency offset of the unwanted interfering signal from the assigned channel frequency of the wanted signal.		

Table 15c: Parameters of the wanted signal and the interfering signal for ACS testing for Local Area BS (1,28 Mcps TDD option)

Parameter	Level	Unit
Reference measurement channel data rate	12,2	kbit/s
Wanted signal mean power	-90	dBm
Interfering signal mean power	-41	dBm
F_{uw} (modulated)	1,6	MHz
NOTE: F_{uw} is the frequency offset of the unwanted interfering signal from the assigned channel frequency of the wanted signal.		

4.2.10.3 Conformance

Conformance tests described in clause 5.3.9 shall be carried out.

5 Testing for compliance with technical requirements

5.1 Conditions for testing

Tests defined in the present document shall be carried out at representative points within the boundary limits of the required operational environmental profile.

Where technical performance varies subject to environmental conditions, tests shall be carried out under a sufficient variety of environmental conditions (within the boundary limits of the required operational environmental profile) to give confidence of compliance for the affected technical requirements.

Normally it should be sufficient for all tests to be conducted using normal test conditions except where otherwise stated. For guidance on the use of other test conditions to be used in order to show compliance reference can be made to TS 125 142 [4], clause 5.9.

Many tests in the present document are performed with appropriate frequencies in the bottom, middle and top of the operating frequency band of the BS. These are denoted as RF channels B (bottom), M (middle) and T (top) as defined in TS 125 142 [4], clause 5.3.

5.2 Interpretation of the measurement results

The interpretation of the results recorded in a test report for the measurements described in the present document shall be as follows:

- the measured value related to the corresponding limit will be used to decide whether an equipment meets the requirements of the present document;
- the value of the measurement uncertainty for the measurement of each parameter shall be included in the test report;
- the recorded value of the measurement uncertainty shall be, for each measurement, equal to or lower than the figures in table 16.

For the test methods, according to the present document, the measurement uncertainty figures shall be calculated in accordance with TR 100 028 [2] and shall correspond to an expansion factor (coverage factor) $k = 1,96$ (which provide a confidence level of 95 % in the case where the distributions characterizing the actual measurement uncertainties are normal (Gaussian)).

Table 16 is based on this expansion factor.

Table 16: Maximum measurement uncertainty of the test system

Parameter	Conditions	Uncertainty
5.3.1 Spectrum emission mask	-	$\pm 1,5$ dB
5.3.2 Transmitter adjacent channel leakage power ratio (ACLR)	general requirement:	$\pm 0,8$ dB
	requirement for protection of FDD on adjacent channels: Wide Area BS: Local Area BS:	± 4 dB $\pm 0,8$ dB
	requirement for protection of unsynchronized TDD on adjacent channels (for 3,84 Mcps TDD option BS): Wide Area BS: Local Area BS:	± 4 dB $\pm 0,8$ dB
	requirement for protection of unsynchronized TDD on adjacent channels (for 1,28 Mcps TDD option BS): Wide Area BS: Local Area BS:	± 1 dB $\pm 0,8$ dB
5.3.3 Transmitter spurious emissions	For BS and coexistence bands:	$\pm 2,0$ dB
	outside above: $f \leq 2,2$ GHz	$\pm 1,5$ dB
	$2,2$ GHz $< f \leq 4$ GHz 4 GHz $< f$	$\pm 2,0$ dB $\pm 4,0$ dB
5.3.4 Base station maximum output power	-	$\pm 0,7$ dB
5.3.5 Transmit intermodulation	For spectrum emission mask:	$\pm 2,5$ dB
	For ACLR:	$\pm 2,2$ dB
	For spurious emissions: for BS and coexistence bands:	$\pm 2,8$ dB
	Outside above: $f \leq 2,2$ GHz:	$\pm 2,5$ dB
	$2,2$ GHz $< f \leq 4$ GHz: 4 GHz $< f$: interference signal adjustment	$\pm 2,8$ dB $\pm 4,5$ dB $\pm 1,0$ dB
5.3.6 Receiver spurious emissions	For BS receive band:	$\pm 3,0$ dB
	Outside BS receive band: $f \leq 2,2$ GHz:	$\pm 2,0$ dB
	$2,2$ GHz $< f \leq 4$ GHz: 4 GHz $< f$:	$\pm 2,0$ dB $\pm 4,0$ dB
	Figures apply to the measurement of the EUT and not to any stimulus signals.	

Parameter	Conditions	Uncertainty
5.3.7 Receiver blocking characteristics (3,84 Mcps TDD option)	offset < 15 MHz:	±1,4 dB
	offset ≥ 15 MHz: f ≤ 2,2 GHz: 2,2 GHz < f ≤ 4 GHz: 4 GHz < f:	±1,1 dB ±1,8 dB ±3,2 dB
	offset = absolute difference of centre frequency of the wanted and centre frequency of the interfering signal	
5.3.7 Receiver blocking characteristics (1,28 Mcps TDD option)	offset < 4,8 MHz:	±1,4 dB
	offset ≥ 4,8 MHz: f ≤ 2,2 GHz: 2,2 GHz < f ≤ 4 GHz: 4 GHz < f:	±1,1 dB ±1,8 dB ±3,2 dB
	offset = absolute difference of centre frequency of the wanted and centre frequency of the interfering signal	
5.3.8 Receiver intermodulation characteristics	-	±1,3 dB
5.3.9 Receiver adjacent channel selectivity (ACS)	-	±1,1 dB
<p>NOTE 1: For RF tests it should be noted that the uncertainties in table 16 apply to the Test System operating into a nominal 50 Ω load and do not include system effects due to mismatch between the EUT and the Test System.</p> <p>NOTE 2: Annex G of TR 100 028 [2] provides guidance for the calculation of the uncertainty components relating to mismatch.</p> <p>NOTE 3: If the Test System for a test is known to have a measurement uncertainty greater than that specified in table 16, this equipment can still be used provided that an adjustment is made as follows: any additional uncertainty in the Test System over and above that specified in table 16 is used to tighten the Test Requirements - making the test harder to pass (for some tests, e.g. receiver tests, this may require modification of stimulus signals). This procedure will ensure that a Test System not compliant with table 16 does not increase the probability of passing a EUT that would otherwise have failed a test if a Test System compliant with table 16 had been used.</p>		

5.3 Essential radio test suites

5.3.1 Spectrum emission mask

5.3.1.1 Method of test

5.3.1.1.1 Initial conditions

For 3,84 Mcps TDD option BS supporting 16QAM, the spectrum emission mask requirements shall be tested with the general test set up specified in clause 5.3.1.1.1.2 and also with the special test set up for 16QAM-capable BS specified in clause 5.3.1.1.1.5.

For 1,28 Mcps TDD option BS supporting 16QAM, the spectrum emission mask requirements shall be tested with the general test set up specified in clause 5.3.1.1.1.3 and also with the special test set up for 16QAM-capable BS specified in clause 5.3.1.1.1.4.

5.3.1.1.1.1 General initial conditions

Test environment: normal; see TS 125 142 [4] clause 5.9.

RF channels to be tested: B, M and T; see clause 5.1.

5.3.1.1.1.2 3,84 Mcps TDD option general test set up

- 1) Connect the measuring equipment to the antenna connector of the BS under test.
- 2) Set the parameters of the BS transmitted signal according to table 17.

Table 17: Parameters of the BS transmitted signal for spectrum emission mask testing (3,84 Mcps TDD option)

Parameter	Value/description
TDD Duty Cycle	TS i ; $i = 0, 1, 2, \dots, 14$: transmit: if i is even; receive: if i is odd.
Time slot carrying SCH	TS0
Time slots under test	TS i , i even and non zero
BS output power setting	PRAT
Number of DPCH in each time slot under test	9
Power of each DPCH	1/9 of Base Station output power
Data content of DPCH	real life (sufficient irregular)

5.3.1.1.1.3 1,28 Mcps TDD option general test set up

- 1) Connect the measuring equipment to the antenna connector of the BS under test.
- 2) Set the parameters of the BS transmitted signal according to table 17b.

Table 17a: Parameters of the BS transmitted signal for spectrum emission mask testing (1,28 Mcps TDD option)

Parameter	Value/description
TDD Duty Cycle	TS i ; $i = 0, 1, 2, 3, 4, 5, 6$: transmit: if i is 0,4,5,6; receive: if i is 1,2,3.
Time slots under test	TS 4, TS 5 and TS 6
BS output power setting	PRAT
Number of DPCH in each time slot under test	8
Power of each DPCH	1/8 of Base Station output power
Data content of DPCH	real life (sufficient irregular)

5.3.1.1.1.4 1,28 Mcps TDD option special test set up for 16QAM-capable BS

This test set up only applies for 16QAM-capable BS.

- 1) Connect the measuring equipment to the antenna connector of the BS under test.
- 2) Set the parameters of the BS transmitted signal according to table 17b.

Table 17b: Parameters of the BS transmitted signal for spectrum emission mask testing (1,28 Mcps TDD option 16QAM-capable BS)

Parameter	Value/description
TDD Duty Cycle	TS i ; $i = 0, 1, 2, 3, 4, 5, 6$: transmit, if i is 0,4,5,6; receive, if i is 1,2,3.
Time slots under test	TS 4, TS 5 and TS 6
BS output power setting	PRAT
HS-PDSCH modulation	16QAM
Number of HS-PDSCH in each time slot under test	8
Power of each HS-PDSCH	1/8 of Base Station output power
Data content of HS-PDSCH	real life (sufficient irregular)
Spreading factor	16

5.3.1.1.1.5 3,84 Mcps TDD option special test set up for 16QAM-capable BS

This test set up only applies for 16QAM-capable BS.

- 1) Connect the measuring equipment to the antenna connector of the BS under test.
- 2) Set the parameters of the BS transmitted signal according to table 17c.

Table 17c: Parameters of the BS transmitted signal for spectrum emission mask testing (3,84 Mcps TDD option 16QAM-capable BS)

Parameter	Value/description
TDD Duty Cycle	TS i ; $i = 0, 1, 2, \dots, 14$: transmit, if i is even; receive, if i is odd.
Time slot carrying SCH	TS0
Time slots under test	TS i , i even and non zero
BS output power setting	PRAT
HS-PDSCH modulation	16QAM
Number of HS-PDSCH in each time slot under test	9
Power of each HS-PDSCH	1/9 of Base Station output power
Data content of HS-PDSCH	real life (sufficient irregular)
Spreading factor	16

5.3.1.1.2 Procedure

5.3.1.1.2.1 3,84 Mcps TDD option

Measure the power of the BS spectrum emissions by applying measurement filters with bandwidths as specified in the relevant table in clause 4.2.2.2.1. The characteristic of the filters shall be approximately Gaussian (typical spectrum analyser filters). The centre frequency of the filter shall be stepped in contiguous steps over the ranges of frequency offsets f_{offset} as given in the tables. The step width shall be equal to the respective measurement bandwidth. The time duration of each step shall be sufficiently long to capture one active time slot.

For frequency offsets of the measurement filter centre frequency in the range $4,0 \text{ MHz} \leq f_{\text{offset}} < f_{\text{offset}_{\text{max}}}$, the measurement shall be performed by applying filters with measurement bandwidth of 50 kHz or less and integrating the measured results over the nominal measurement bandwidth 1 MHz.

5.3.1.1.2.2 1,28 Mcps TDD option

Measure the power of the BS spectrum emissions by applying measurement filters with bandwidths as specified in the relevant table in clause 4.2.2.2.2. The characteristic of the filters shall be approximately Gaussian (typical spectrum analyser filters). The centre frequency of the filter shall be stepped in contiguous steps over the ranges of frequency offsets f_{offset} as given in the tables. The step width shall be equal to the respective measurement bandwidth. The time duration of each step shall be sufficiently long to capture one active time slot.

For frequency offsets of the measurement filter centre frequency in the range $2,3 \text{ MHz} \leq f_{\text{offset}} < f_{\text{offset}_{\text{max}}}$, the measurement shall be performed by applying filters with measurement bandwidth of 50 kHz or less and integrating the measured results over the nominal measurement bandwidth 1 MHz.

5.3.1.2 Test requirements

5.3.1.2.1 3,84 Mcps TDD option

The spectrum emissions measured according to clause 5.3.1.1.2.1 shall not exceed the maximum level specified in tables 3 to 6 for the appropriate BS rated output power table of clause 4.2.2.2.1.

5.3.1.2.2 1,28 Mcps TDD option

The spectrum emissions measured according to clause 5.3.1.1.2.2 shall not exceed the maximum level specified in tables 6a to 6c for the appropriate BS rated output power table of clause 4.2.2.2.2.

5.3.2 Transmitter adjacent channel leakage power ratio

5.3.2.1 Method of test

5.3.2.1.1 Initial conditions

For 3,84 Mcps TDD option BS supporting 16QAM, the transmitter adjacent channel leakage power ratio requirements shall be tested with the general test set up specified in clause 5.3.2.1.1.2 also with the special test set up for 16QAM-capable BS specified in clause 5.3.2.1.1.5.

For 1,28 Mcps TDD option BS supporting 16QAM, the transmitter adjacent channel leakage power ratio requirements shall be tested with the general test set up specified in clause 5.3.2.1.1.3 also with the special test set up for 16QAM-capable BS specified in clause 5.3.2.1.1.4.

5.3.2.1.1.1 General initial conditions

Test environment: normal; see TS 125 142 [4] clause 5.9.

RF channels to be tested: B, M and T with multiple carriers if supported; see clause 5.1.

5.3.2.1.1.2 3,84 Mcps TDD option general test set up

- 1) Connect the measuring equipment to the antenna connector of the BS under test.
- 2) Set the parameters of the BS transmitted signal according to table 18.

Table 18: Parameters of the BS transmitted signal for ACLR testing (3,84 Mcps TDD option)

Parameter	Value/description
TDD Duty Cycle	TS i ; $i = 0, 1, 2, \dots, 14$: transmit: if i is even; receive: if i is odd.
Time slot carrying SCH	TS0
Time slots under test	TS l , l even and non zero
BS output power setting	PRAT
Number of DPCH in each time slot under test	9
Power of each DPCH	1/9 of Base Station output power
Data content of DPCH	Real life (sufficient irregular)

5.3.2.1.1.3 1,28 Mcps TDD option general test set up

- 1) Connect the measuring equipment to the antenna connector of the BS under test.
- 2) Set the parameters of the BS transmitted signal according to table 18a.

**Table 18a: Parameters of the BS transmitted signal for ACLR testing
(1,28 Mcps TDD option)**

Parameter	Value/description
TDD Duty Cycle	TS i ; $i = 0, 1, 2, 3, 4, 5, 6$: transmit, if i is 0,4,5,6 receive, if i is 1,2,3.
Time slots under test	TS 4, TS 5 and TS 6
BS output power setting	PRAT
Number of DPCH in each time slot under test	8
Power of each DPCH	1/8 of Base Station output power
Data content of DPCH	real life (sufficient irregular)

5.3.2.1.1.4 1,28 Mcps TDD option special test set up for 16QAM-capable BS

This test set up only applies for 16QAM-capable BS.

- 1) Connect the measuring equipment to the antenna connector of the BS under test.
- 2) Set the parameters of the BS transmitted signal according to table 18b.

**Table 18b: Parameters of the BS transmitted signal for ACLR testing
(1,28 Mcps TDD option 16QAM-capable BS)**

Parameter	Value/description
TDD Duty Cycle	TS i ; $i = 0, 1, 2, 3, 4, 5, 6$: transmit: if i is 0,4,5,6; receive: if i is 1,2,3.
Time slots under test	TS4, TS 5 and TS 6
BS output power setting	PRAT
HS-PDSCH modulation	16QAM
Number of HS-PDSCH in each time slot under test	8
Power of each HS-PDSCH	1/8 of Base Station output power
Data content of HS-PDSCH	real life (sufficient irregular)
Spreading factor	16

5.3.2.1.1.5 3,84 Mcps TDD option special test set up for 16QAM-capable BS

This test set up only applies for 16QAM-capable BS.

- 1) Connect the measuring equipment to the antenna connector of the BS under test.
- 2) Set the parameters of the BS transmitted signal according to table 18c.

**Table 18c: Parameters of the BS transmitted signal for ACLR testing
(3,84 Mcps TDD option 16QAM-capable BS)**

Parameter	Value/description
TDD Duty Cycle	TS i ; $i = 0, 1, 2, \dots, 14$: transmit, if i is even; receive, if i is odd.
Time slot carrying SCH	TS0
Time slots under test	TS i , i even and non zero
BS output power setting	PRAT
HS-PDSCH modulation	16QAM
Number of HS-PDSCH in each time slot under test	9
Power of each HS-PDSCH	1/9 of Base Station output power
Data content of HS-PDSCH	real life (sufficient irregular)
Spreading factor	16

5.3.2.1.2 Procedure

5.3.2.1.2.1 3,84 Mcps TDD option

- 1) Measure RRC filtered mean power centred on the assigned channel frequency over the 2 464 active chips of the even time slots TS *i* (this excludes the guard period).
- 2) Average over the number of time slots defined in TS 125 142 [4].
- 3) Measure the RRC filtered mean power at the first lower adjacent RF channel (centre frequency 5 MHz below the assigned channel frequency of the transmitted signal) over the useful part of the burst within the even time slots TS *i* (this excludes the guard period).
- 4) Average over the number of time slots defined in TS 125 142 [4].
- 5) Calculate the ACLR by the ratio:
 - $ACLR = \text{average power according to (2)} / \text{average power according to (4)}$.
- 6) Repeat steps (3), (4) and (5) for the second lower adjacent RF channel (centre frequency 10 MHz below the assigned channel frequency of the transmitted signal).
- 7) In case of a multi-carrier BS, repeat steps (1) and (2) for the highest assigned channel frequency. Otherwise, use the result obtained in step (2) above for further calculation in step (10).
- 8) Measure the RRC filtered mean power at the first higher adjacent RF channel (centre frequency 5 MHz above the highest assigned channel frequency of the transmitted signal) over the useful part of the burst within the even time slots TS *i* (this excludes the guard period).
- 9) Average over the number of time slots defined in TS 125 142 [4].
- 10) Calculate the ACLR by the ratio:
 - $ACLR = \text{average power according to (7)} / \text{average power according to (9)}$.
- 11) Repeat steps (8) to (10) for the second higher adjacent RF channel (centre frequency 10 MHz above the highest assigned channel frequency of the transmitted signal).

5.3.2.1.2.2 1,28 Mcps TDD option

- 1) Measure RRC filtered mean power centred on the assigned channel frequency over the 848 active chips of the transmit time slots TS *i* (this excludes the guard period).
- 2) Average over the number of time slots defined in TS 125 142 [4].
- 3) Measure the RRC filtered mean power at the first lower adjacent RF channel (centre frequency 1,6 MHz below the assigned channel frequency of the transmitted signal) over the useful part of the burst within the transmit time slots TS *i* (this excludes the guard period).
- 4) Average over the number of time slots defined in TS 125 142 [4].
- 5) Calculate the ACLR by the ratio:
 - $ACLR = \text{average power according to (2)} / \text{average power according to (4)}$.
- 6) Repeat steps (3), (4) and (5) for the second lower adjacent RF channel (centre frequency 3,2 MHz below the assigned channel frequency of the transmitted signal).
- 7) In case of a multi-carrier BS, repeat steps (1) and (2) for the highest assigned channel frequency. Otherwise, use the result obtained in step (2) above for further calculation in step (10).
- 8) Measure the RRC filtered mean power at the first higher adjacent RF channel (centre frequency 1,6 MHz above the highest assigned channel frequency of the transmitted signal) over the useful part of the burst within the transmit time slots TS *i* (this excludes the guard period).
- 9) Average over the number of time slots defined in TS 125 142 [4].

10) Calculate the ACLR by the ratio:

- $ACLR = \text{average power according to (7)} / \text{average power according to (9)}$.

11) Repeat steps (8) to (10) for the second higher adjacent RF channel (centre frequency 3,2 MHz above the highest assigned channel frequency of the transmitted signal).

5.3.2.2 Test requirements

5.3.2.2.1 3,84 Mcps TDD option

The ACLR calculated in steps (5) and (10) of clause 5.3.2.1.2.1 shall be equal or greater than the limits given in table 7. The adjacent channel leakage power measured according to step (9) of clause 5.3.2.1.2.1 shall not exceed the maximum levels specified in table 7b for adjacent channels in the frequency range specified in table 7b.

5.3.2.2.2 1,28 Mcps TDD option

The ACLR calculated in steps (5) and (10) of clause 5.3.2.1.2.2 shall be equal or greater than the limits given in table 7a. The adjacent channel leakage power measured according to step (9) of clause 5.3.2.1.2.2 shall not exceed the maximum level specified in table 7c for the measurement frequency specified in table 7c.

5.3.3 Transmitter spurious emissions

5.3.3.1 Method of test

5.3.3.1.1 Initial conditions

For 3,84 Mcps TDD option BS supporting 16QAM, the transmitter spurious emission requirements shall be tested with the general test set up specified in clause 5.3.3.1.1.2 and also with the special test set up for 16QAM-capable BS specified in clause 5.3.3.1.1.5.

For 1,28 Mcps TDD option BS supporting 16QAM, the transmitter spurious emission requirements shall be tested with the general test set up specified in clause 5.3.3.1.1.3 and also with the special test set up for 16QAM-capable BS specified in clause 5.3.3.1.1.4.

5.3.3.1.1.1 General initial conditions

Test environment: normal; see TS 125 142 [4] clause 5.9.

RF channels to be tested: B, M and T with multiple carriers if supported; see clause 5.1.

5.3.3.1.1.2 3,84 Mcps TDD option general test set up

- 1) Connect the measuring equipment to the antenna connector of the BS under test.
- 2) Set the parameters of the BS transmitted signal according to table 19.

Table 19: Parameters of the BS transmitted signal for spurious emissions testing (3,84 Mcps TDD option)

Parameter	Value/description
TDD Duty Cycle	TS i ; $i = 0, 1, 2, \dots, 14$: transmit, if i is even; Receive, if i is odd.
Time slot carrying SCH	TS0
Time slots under test	TS i , i even and non zero
BS output power setting	PRAT
Number of DPCH in each time slot under test	9
Power of each DPCH	1/9 of Base Station output power
Data content of DPCH	real life (sufficient irregular)

5.3.3.1.1.3 1,28 Mcps TDD option general test set up

- 1) Connect the measuring equipment to the antenna connector of the BS under test.
- 2) Set the parameters of the BS transmitted signal according to table 19a.

Table 19a: Parameters of the BS transmitted signal for spurious emission testing (1,28 Mcps TDD option)

Parameter	Value/description
TDD Duty Cycle	TS i; i = 0, 1, 2, 3, 4, 5, 6: transmit, if i is 0,4,5,6; Receive, if i is 1,2,3.
Time slots under test	TS 4, TS 5 and TS 6
BS output power setting	PRAT
Number of DPCH in each time slot under test	8
Power of each DPCH	1/8 of Base Station output power
Data content of DPCH	real life (sufficient irregular)

5.3.3.1.1.4 1,28 Mcps TDD option special test set up for 16QAM-capable BS

This test set up only applies for 16QAM-capable BS.

- 1) Connect the measuring equipment to the antenna connector of the BS under test.
- 2) Set the parameters of the BS transmitted signal according to table 19b.

Table 19b: Parameters of the BS transmitted signal for spurious emission testing (1,28 Mcps TDD option 16QAM-capable BS)

Parameter	Value/description
TDD Duty Cycle	TS i; i = 0, 1, 2, 3, 4, 5, 6: transmit, if i is 0,4,5,6; Receive, if i is 1,2,3.
Time slots under test	TS 4, TS 5 and TS 6
BS output power setting	PRAT
HS-PDSCH modulation	16QAM
Number of HS-PDSCH in each time slot under test	8
Power of each HS-PDSCH	1/8 of Base Station output power
Data content of HS-PDSCH	real life (sufficient irregular)
Spreading factor	16

5.3.3.1.1.5 3,84 Mcps TDD option special test set up for 16QAM-capable BS

This test set up only applies for 16QAM-capable BS.

- 1) Connect the measuring equipment to the antenna connector of the BS under test.
- 2) Set the parameters of the BS transmitted signal according to table 19c.

Table 19c: Parameters of the BS transmitted signal for spurious emission testing (3,84 Mcps TDD option 16QAM-capable BS)

Parameter	Value/description
TDD Duty Cycle	TS i ; $i = 0, 1, 2, \dots, 14$: transmit, if i is even; receive, if i is odd.
Time slot carrying SCH	TS0
Time slots under test	TS i , i even and non zero
BS output power setting	PRAT
HS-PDSCH modulation	16QAM
Number of HS-PDSCH in each time slot under test	9
Power of each HS-PDSCH	1/9 of Base Station output power
Data content of HS-PDSCH	real life (sufficient irregular)
Spreading factor	16

5.3.3.1.2 Procedure

Measure the power of the spurious emissions by applying measurement filters with bandwidths as specified in the relevant tables of clause 4.2.4.2. The characteristics of the measurement filter with the bandwidth 1,28 MHz or 3,84 MHz shall be RRC with roll-off $\alpha = 0,22$. The characteristics of the measurement filters with bandwidths 100 kHz and 1 MHz shall be approximately Gaussian (typical spectrum analyzer filter). The centre frequency of the filter shall be stepped in contiguous steps over the frequency bands as given in the tables. The step width shall be equal to the respective measurement bandwidth. The time duration of each step shall be sufficiently long to capture one active time slot.

5.3.3.2 Test requirements

The spurious emissions measured according to clause 5.3.3.1.2 shall not exceed the limits specified in the relevant tables of clause 4.2.4.2.

5.3.4 Base station maximum output power

5.3.4.1 Method of test

5.3.4.1.1 Initial conditions

5.3.4.1.1.1 General initial conditions

Test environment: Normal; see TS 125 142 [4], clause 5.9.

RF channels to be tested: B, M and T; see clause 5.1.

In addition, on one UARFCN only, the test shall be performed under extreme power supply as defined in TS 125 142 [4], clause 5.9.

NOTE: Tests under extreme power supply also test extreme temperature.

5.3.4.1.1.2 3,84 Mcps TDD option

- 1) The transmitter under test and all other transmitters of the base station (if any) are switched on.
- 2) The power of the transmitters not under test (if any) are controlled down.
- 3) Connect the power measuring equipment to the BS antenna connector.
- 4) Set the parameters of the transmitted signal according to table 20.

Table 20: Parameters of the transmitted signal for maximum output power test (3,84 Mcps TDD option)

Parameter	Value/description
TDD Duty Cycle	TS i; i = 0, 1, 2, ..., 14: transmit, if i is even; receive, if i is odd.
Time slot carrying SCH	TS0
Time slots under test	TS i, i even and non zero
BS output power setting	PRAT
Number of DPCH in each time slot under test	9
Power of each DPCH	1/9 of Base Station output power
Data content of DPCH	real life (sufficient irregular)

5.3.4.1.1.3 1,28 Mcps TDD option

- 1) The transmitter under test and all other transmitters of the base station (if any) are switched on.
- 2) The power of the transmitters not under test (if any) are controlled down.
- 3) Connect the power measuring equipment to the BS antenna connector.
- 4) Set the parameters of the transmitted signal according to table 20a.

Table 20a: Parameters of the transmitted signal for maximum output power test (1,28 Mcps TDD option)

Parameter	Value/description
TDD Duty Cycle	TS i; i = 0, 1, 2, 3, 4, 5, 6: transmit, if i is 0,4,5,6; Receive, if i is 1,2,3.
Time slots under test	TS 4, TS 5 and TS 6
BS output power setting	PRAT
Number of DPCH in each time slot under test	8
Power of each DPCH	1/8 of Base Station output power
Data content of DPCH	real life (sufficient irregular)

5.3.4.1.2 Procedure

5.3.4.1.2.1 3,84 Mcps TDD option

- 1) Measure the output power of the BS signal.
- 2) Run step (1) for RF channels B/M/T.

5.3.4.1.2.2 1,28 Mcps TDD option

- 1) Measure the output power of the BS signal.
- 2) Run step (1) for RF channels B/M/T.

5.3.4.2 Test requirements

The value of the measured output power, derived according to clause 5.3.4.1.2, shall be within the tolerance defined in clause 4.2.5.2.

5.3.5 Transmit intermodulation

5.3.5.1 Method of test

5.3.5.1.1 Initial conditions

For 3,84 Mcps TDD option BS supporting 16QAM, the transmit intermodulation requirements shall be tested with the general test set up specified in clause 5.3.5.1.1.2 and also with the special test set up for 16QAM-capable BS specified in clause 5.3.5.1.1.5.

For 1,28 Mcps TDD option BS supporting 16QAM, the transmit intermodulation requirements shall be tested with the general test set up specified in clause 5.3.5.1.1.3 and also with the special test set up for 16QAM-capable BS specified in clause 5.3.5.1.1.4.

5.3.5.1.1.1 General initial conditions

Test environment: Normal; see TS 125 142 [4], clause 5.9.

RF channels to be tested: B, M and T; see clause 5.1.

5.3.5.1.1.2 3,84 Mcps TDD option general test set up

- 1) Connect the measuring equipment, the BS under test and the CDMA signal generator as shown in figure 1

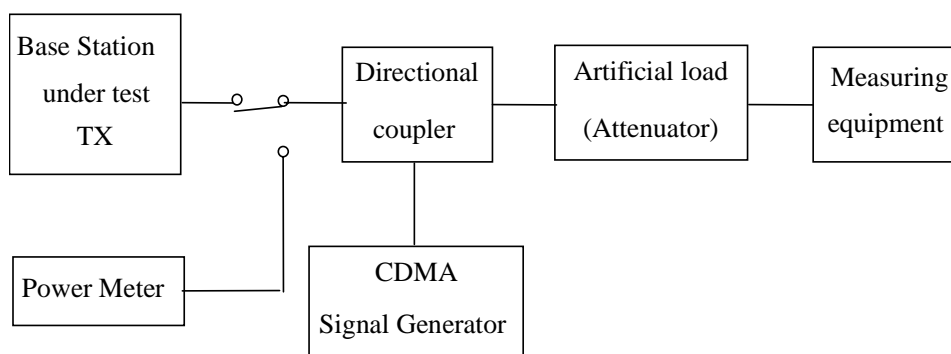

Figure 1: Measuring setup for Base Station transmit intermodulation testing (3,84 Mcps TDD option)

- 2) Set the parameters of the BS transmitted signal according to table 21.

Table 21: Parameters of the BS transmitted signal for transmit intermodulation testing (3,84 Mcps TDD option)

Parameter	Value/description
TDD Duty Cycle	TS i ; $i = 0, 1, 2, \dots, 14$: transmit, if i is odd; Receive, if i is even.
Time slot carrying SCH	TS0
Time slots under test	TS i , i even and non zero
BS output power setting	PRAT
Number of DPCH in each time slot under test	9
Power of each DPCH	1/9 of Base Station output power
Data content of DPCH	real life (sufficient irregular)

- 3) Configure the CDMA signal generator to produce an interference signal with a level of 30 dB lower than that of the BS transmitted signal. The interference signal shall be like-modulated as the BS transmitted signal, and the active time slots of both signals shall be synchronized. The frequency of the interference signal shall be ± 5 MHz, ± 10 MHz and ± 15 MHz offset from the BS transmitted signal but excluding interference frequencies outside the frequency range 1900 MHz to 1920 MHz and 2010 MHz to 2025 MHz respectively.

5.3.5.1.1.3 1,28 Mcps TDD option general test set up

- 1) Connect the measuring equipment, the BS under test and the 1,28 Mcps TDD signal generator as shown in figure 1a.

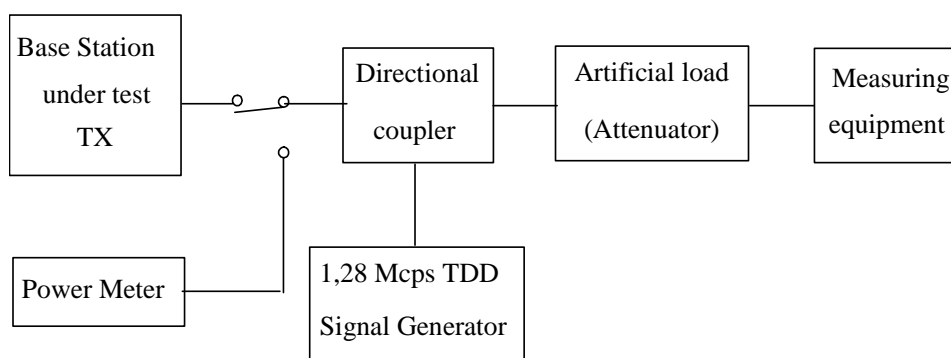

Figure 1a: Measuring setup for Base Station transmit intermodulation testing (1,28 Mcps TDD option)

- 2) Set the parameters of the BS transmitted signal according to table 21a.

Table 21a: Parameters of the BS transmitted signal for transmit intermodulation testing (1,28 Mcps TDD option)

Parameter	Value/description
TDD Duty Cycle	TS i ; $i = 0, 1, 2, 3, 4, 5, 6$: transmit, if i is 0,4,5,6; receive, if i is 1,2,3.
Time slots under test	TS 4, TS 5 and TS 6
BS output power setting	PRAT
Number of DPCH in each time slot under test	8
Power of each DPCH	1/8 of Base Station output power
Data content of DPCH	real life (sufficient irregular)

- 3) Configure the 1,28 Mcps TDD signal generator to produce an interference signal with a level of 30 dB lower than that of the BS transmitted signal. The interference signal shall be like-modulated as the BS transmitted signal, and the active time slots of both signals shall be synchronized. The frequency of the interference signal shall be $\pm 1,6$ MHz, $\pm 3,2$ MHz and $\pm 4,8$ MHz offset from the BS transmitted signal but excluding interference frequencies outside the frequency range 1900 MHz to 1920 MHz and 2010 MHz to 2025 MHz respectively.

5.3.5.1.1.4 1,28 Mcps TDD option special test set up for 16QAM-capable BS

This test set up only applies for 16QAM-capable BS.

- 1) Connect the measuring equipment, the BS under test and the 1.28 Mcps TDD signal generator as shown in figure 1b.

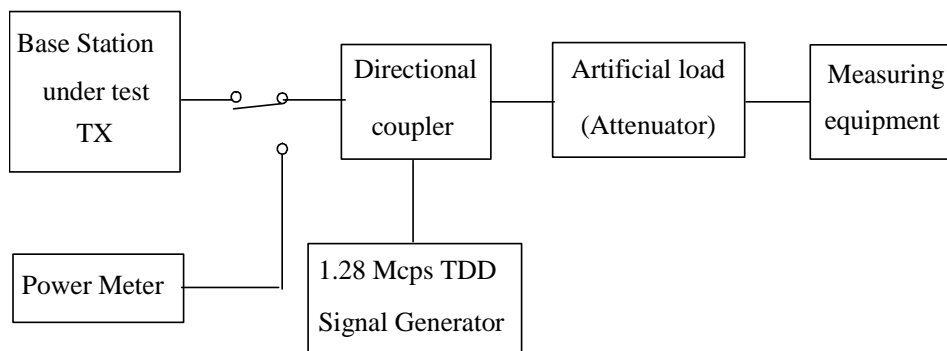

Figure 1b: Measuring setup for Base Station transmit intermodulation testing (1,28 Mcps TDD option 16QAM-capable BS)

- 2) Set the parameters of the BS transmitted signal according to table 21b.

Table 21b: Parameters of the BS transmitted signal for transmit intermodulation testing (1,28 Mcps TDD option 16QAM-capable BS)

Parameter	Value/description
TDD Duty Cycle	TS i ; $i = 0, 1, 2, 3, 4, 5, 6$: transmit, if i is 0,4,5,6; receive, if i is 1,2,3.
Time slots under test	TS 4, TS 5 and TS 6
BS output power setting	PRAT
HS-PDSCH modulation	16QAM
Number of HS-PDSCH in each time slot under test	8
Power of each HS-PDSCH	1/8 of Base Station output power
Data content of HS-PDSCH	real life (sufficient irregular)
Spreading factor	16

- 3) Configure the 1.28 Mcps TDD signal generator to produce an interference signal with a level of 30 dB lower than that of the BS transmitted signal. The interference signal shall be like-modulated as the BS transmitted signal, and the active time slots of both signals shall be synchronized. The frequency of the interference signal shall be $\pm 1,6$ MHz, $\pm 3,2$ MHz and $\pm 4,8$ MHz offset from the BS transmitted signal but excluding interference frequencies outside the frequency range 1900 MHz to 1920 MHz and 2010 MHz to 2025 MHz respectively.

5.3.5.1.1.5 3,84 Mcps TDD option special test set up for 16QAM-capable BS

This test set up only applies for 16QAM-capable BS.

- 1) Connect the measuring equipment, the BS under test and the CDMA signal generator as shown in figure 1c.

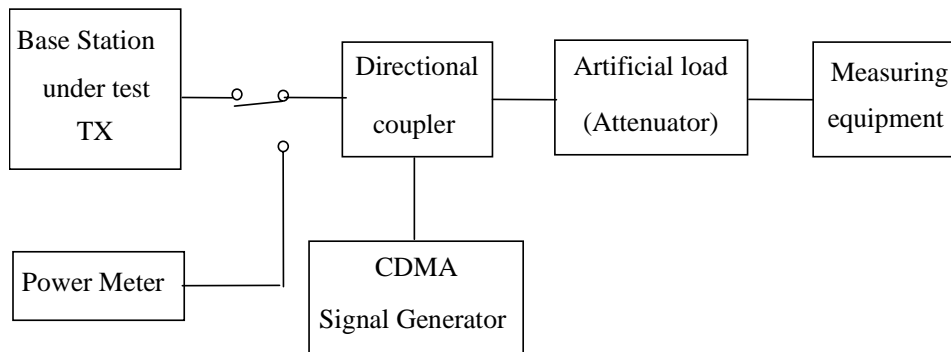

Figure 1c: Measuring setup for Base Station transmit intermodulation testing (3,84 Mcps TDD option 16QAM-capable BS)

- 2) Set the parameters of the BS transmitted signal according to table 21c.

Table 21c: Parameters of the BS transmitted signal for transmit intermodulation testing (3,84 Mcps TDD option 16QAM-capable BS)

Parameter	Value/description
TDD Duty Cycle	TS i ; $i = 0, 1, 2, \dots, 14$: transmit, if i is even; receive, if i is odd.
Time slot carrying SCH	TS0
Time slots under test	TS i , i even and non zero
BS output power setting	PRAT
HS-PDSCH modulation	16QAM
Number of HS-PDSCH in each time slot under test	9
Power of each HS-PDSCH	1/9 of Base Station output power
Data content of HS-PDSCH	real life (sufficient irregular)
Spreading factor	16

- 3) Configure the CDMA signal generator to produce an interference signal with a level of 30 dB lower than that of the BS transmitted signal. The interference signal shall be like-modulated as the BS transmitted signal, and the active time slots of both signals shall be synchronized. The frequency of the interference signal shall be ± 5 MHz, ± 10 MHz and ± 15 MHz offset from the BS transmitted signal but excluding interference frequencies outside the frequency range 1900 MHz to 1920 MHz and 2010 MHz to 2025 MHz respectively.

5.3.5.1.2 Procedure

Apply the test procedures for out of band described in clauses 5.3.1.1 and 5.3.2.1 and for transmitter spurious emissions as described in clause 5.3.3.1 at the frequencies of all third and fifth order intermodulation products. The frequency band occupied by the interference signal are excluded from the measurements.

5.3.5.2 Test requirements

The conformance requirements for out of band as specified in clauses 4.2.2.2 and 4.2.3.2 and for transmitter spurious emissions as specified in clause 4.2.4.2 shall be met at the frequencies of all third and fifth order intermodulation products.

5.3.6 Receiver spurious emissions

5.3.6.1 Method of test

5.3.6.1.1 Initial conditions

5.3.6.1.1.1 General initial conditions

Test environment: normal; see TS 125 142 [4], clause 5.9.

RF channels to be tested: M; see clause 5.1.

5.3.6.1.1.2 3,84 Mcps TDD option

- 1) Connect the measuring equipment to the antenna connector of one BS Rx port.
- 2) Terminate or disable any other BS Rx port not under test.
- 3) Set the BS receiver to operational mode.
- 4) Set the BS to transmit a signal with parameters according to table 22.
- 5) Terminate the Tx port(s).

Table 22: Parameters of the transmitted signal for receiver spurious emissions test (3,84 Mcps TDD option)

Parameter	Value/description
TDD Duty Cycle	TS i; i = 0, 1, 2, ..., 14: transmit, if i is even; receive, if i is odd.
Time slot carrying SCH	TS0
Time slots under test	TS i, i even and non zero
BS output power setting	PRAT
Number of DPCH in each time slot under test	9
Power of each DPCH	1/9 of Base Station output power
Data content of DPCH	real life (sufficient irregular)

5.3.6.1.1.3 1,28 Mcps TDD option

- 1) Connect the measuring equipment to the antenna connector of one BS Rx port.
- 2) Terminate or disable any other BS Rx port not under test.
- 3) Set the BS receiver to operational mode.
- 4) Set the BS to transmit a signal with parameters according to table 22a.
- 5) Terminate the Tx port(s).

Table 22a: Parameters of the transmitted signal for receiver spurious emissions test (1,28 Mcps TDD option)

Parameter	Value/description
TDD Duty Cycle	TS i; i = 0, 1, 2, 3, 4, 5, 6: transmit, if i is 0,4,5,6; receive, if i is 1,2,3.
Time slots under test	TS 4, TS 5 and TS 6
BS output power setting	PRAT
Number of DPCH in each time slot under test	8
Power of each DPCH	1/8 of Base Station output power
Data content of DPCH	real life (sufficient irregular)

5.3.6.1.2 Procedure

5.3.6.1.2.1 3,84 Mcps TDD option

- 1) Measure the power of the spurious emissions by applying the measuring equipment with the settings as specified in table 23. The characteristics of the measurement filter with the bandwidth 3,84 MHz shall be RRC with roll-off $\alpha = 0,22$. The characteristics of the measurement filters with bandwidths 100 kHz and 1 MHz shall be approximately Gaussian (typical spectrum analyser filter). The centre frequency of the filters shall be stepped in contiguous steps over the frequency bands as specified in table 23. The time duration of each step shall be sufficiently long to capture one even (transmit) time slot.
- 2) If the BS is equipped with more than one Rx port, interchange the connections of the BS Rx ports and repeat the measurement according to 1).

Table 23: Measurement equipment settings (3,84 Mcps TDD option)

Stepped frequency range	Measurement bandwidth	Step width	Note	Detection mode
30 MHz to 1 GHz	100 kHz	100 kHz	With the exception of frequencies between 12,5 MHz below the first carrier frequency and 12,5 MHz above the last carrier frequency used by the BS	true RMS
1 GHz to 1900 GHz	1 MHz	1 MHz		
1900 GHz to 1980 GHz	3,84 MHz	200 kHz		
1980 GHz to 2010 GHz	1 MHz	1 MHz		
2010 GHz to 2025 GHz	3,84 MHz	200 kHz		
2025 GHz to 2500 GHz	1 MHz	1 MHz		
2500 GHz to 2620 GHz	3,84 MHz	200 kHz		
2620 GHz to 12,75 GHz	1 MHz	1 MHz		

5.3.6.1.2.2 1,28 Mcps TDD option

- 1) Measure the power of the spurious emissions by applying the measuring equipment with the settings as specified in table 23a. The characteristics of the measurement filter with the bandwidth 1,28 MHz shall be RRC with roll-off $\alpha = 0,22$. The characteristics of the measurement filters with bandwidths 100 kHz and 1 MHz shall be approximately Gaussian (typical spectrum analyser filter). The centre frequency of the filters shall be stepped in contiguous steps over the frequency bands as specified in table 23a. The time duration of each step shall be sufficiently long to capture one transmit time slot.
- 2) If the BS is equipped with more than one Rx port, interchange the connections of the BS Rx ports and repeat the measurement according to (1).

Table 23a: Measurement equipment settings (1,28 Mcps TDD option)

Stepped frequency range	Measurement bandwidth	Step width	Note	Detection mode
30 MHz to 1 GHz	100 kHz	100 kHz	With the exception of frequencies between 4 MHz below the first carrier frequency and 4 MHz above the last carrier frequency used by the BS	true RMS
1 GHz to 1900 GHz	1 MHz	1 MHz		
1900 GHz to 1980 GHz	1,28 MHz	200 kHz		
1980 GHz to 2010 GHz	1 MHz	1 MHz		
2010 GHz to 2025 GHz	1,28 MHz	200 kHz		
2025 GHz to 2500 GHz	1 MHz	1 MHz		
2500 GHz to 2620 GHz	1,28 MHz	200 kHz		
2620 GHz to 12,75 GHz	1 MHz	1 MHz		

5.3.6.2 Test requirements

The receiver spurious emissions measured according to clause 5.3.6.1.2 shall not exceed the limits specified in clause 4.2.7.2.

5.3.7 Receiver blocking characteristics

5.3.7.1 Method of test

5.3.7.1.1 Initial conditions

Test environment: normal; see TS 125 142 [4], clause 5.9.

RF channels to be tested: M; see clause 5.1.

The BS shall be configured to operate as close to the centre of the operating band as possible.

- 1) Connect an UE simulator operating at the assigned channel frequency of the wanted signal and a signal generator to the antenna connector of one Rx port.
- 2) Terminate or disable any other Rx port not under test.
- 3) Start transmission from the BS tester to the BS using the UL reference measurement channel (12,2 kbit/s) defined in TS 125 105 [3] annex A. The level of the UE simulator signal measured at the BS antenna connector shall be set to -103 dBm for the 3,84 Mcps TDD option Wide Area BS, -89 dBm for the 3,84 Mcps TDD option Local Area BS, -104 dBm for the 1,28 Mcps TDD option Wide Area BS and -90 dBm for the 1,28 Mcps TDD option Local Area BS, respectively.

5.3.7.1.2 Procedure

5.3.7.1.2.1 3,84 Mcps TDD option

- 1) Set the signal generator to produce an interfering signal at a frequency offset F_{uw} from the assigned channel frequency of the wanted signal which is given by:

$$F_{uw} = \pm (n \times 1 \text{ MHz});$$

where n shall be increased in integer steps from $n = 10$ up to such a value that the centre frequency of the interfering signal covers the range from 1 MHz to 12,75 GHz. The interfering signal level measured at the antenna connector shall be set in dependency of its centre frequency, as specified in table 13 for the Wide Area BS and table 13a for the Local Area BS respectively. The type of the interfering signal is either equivalent to a continuous wideband CDMA signal with one code of chip frequency 3,84 Mchip/s, filtered by an RRC transmit pulse-shaping filter with roll-off $\alpha = 0,22$, or a CW signal; see tables 13 and 13a.

- 2) Measure the BER of the wanted signal at the BS receiver.
- 3) Interchange the connections of the BS Rx ports and repeat the measurements according to steps (1) and (2).

5.3.7.1.2.2 1,28 Mcps TDD option

- 1) Set the signal generator to produce an interfering signal at a frequency offset F_{uw} from the assigned channel frequency of the wanted signal which is given by:

$$F_{uw} = \pm (3,2 + n) \times 1 \text{ MHz},$$

where n shall be increased in integer steps from $n = 0$ up to such a value that the centre frequency of the interfering signal covers the range from 1 MHz to 12,75 GHz. The interfering signal level measured at the antenna connector shall be set in dependency of its centre frequency, as specified in table 13b for the Wide Area BS and 13c for the Local Area BS respectively. The type of the interfering signal is either equivalent to a continuous wideband CDMA signal with one code of chip frequency 1,28 Mchip/s, filtered by an RRC transmit pulse-shaping filter with roll-off $\alpha = 0,22$, or a CW signal; see tables 13b and 13c.

- 2) Measure the BER of the wanted signal at the BS receiver.
- 3) Interchange the connections of the BS Rx ports and repeat the measurements according to steps 1) and 2).

5.3.7.2 Test requirements

In all measurements made according to clause 5.3.7.1.2, the BER shall not exceed 0,001.

NOTE: TS 125 142 [4] Annex F describes the procedure for BER tests taking into account the statistical consequence of frequent repetition of BER measurements within the blocking test. The consequence is: a DUT exactly on the limit may fail due to the statistical nature 2,55 times (mean value) in 12 750 BER measurements using the predefined wrong decision probability of 0,02 %. If the fail cases are ≤ 12 , it is allowed to repeat the fail cases 1 time before the final verdict.

5.3.8 Receiver intermodulation characteristics

5.3.8.1 Method of test

5.3.8.1.1 Initial conditions

Test environment: normal; see TS 125 142 [4] clause 5.9.

RF channels to be tested: B, M and T; see clause 5.1.

- 1) Connect an UE simulator operating at the assigned channel frequency of the wanted signal and two signal generators to the antenna connector of one Rx port.
- 2) Terminate or disable any other Rx port not under test.
- 3) Start transmission from the BS tester to the BS using the UL reference measurement channel (12,2 kbit/s) defined in TS 125 105 [3], annex A. The level of the UE simulator signal measured at the BS antenna connector shall be set to as specified in tables 24 and 25.

Table 24: Wanted signal level for intermodulation characteristics testing (3,84 Mcps TDD option)

BS class	Wanted signal level
Wide Area BS	-103 dBm
Local Area BS	-89 dBm

Table 25: Wanted signal level for intermodulation characteristics testing (1,28 Mcps TDD option)

BS class	Wanted signal level
Wide Area BS	-104 dBm
Local Area BS	-90 dBm

- 4) Set the first signal generator to produce a CW signal with a level measured at the BS antenna connector as specified in table 14 for the 3,84 Mcps TDD option and table 14a for the 1,28 Mcps TDD option respectively.
- 5) Set the second signal generator to produce an interfering signal equivalent to a wideband CDMA signal with one code of chip frequency 3,84 Mchip/s for the 3,84 Mcps TDD option and 1,28 Mcps for the 1,28 Mcps TDD option respectively, filtered by an RRC transmit pulse-shaping filter with roll-off $\alpha = 0,22$. The level of the signal measured at the BS antenna connector shall be set as specified in table 14 for the 3,84 Mcps TDD option and table 14a for the 1,28 Mcps TDD option respectively.

5.3.8.1.2 Procedure

5.3.8.1.2.1 3,84 Mcps TDD option

- 1) The frequency of the first and the second signal generator shall be set to 10 MHz and 20 MHz, respectively, above the assigned channel frequency of the wanted signal.
- 2) Measure the BER of the wanted signal at the BS receiver.
- 3) The frequency of the first and the second signal generator shall be set to 10 MHz and 20 MHz, respectively, below the assigned channel frequency of the wanted signal.
- 4) Measure the BER of the wanted signal at the BS receiver.
- 5) Interchange the connections of the BS Rx ports and repeat the measurements according to steps (1) to (4).

5.3.8.1.2.2 1,28 Mcps TDD option

- 1) The frequency of the first and the second signal generator shall be set to 3,2 MHz and 6,4 MHz, respectively, above the assigned channel frequency of the wanted signal.
- 2) Measure the BER of the wanted signal at the BS receiver.
- 3) The frequency of the first and the second signal generator shall be set to 3,2 MHz and 6,4 MHz, respectively, below the assigned channel frequency of the wanted signal.
- 4) Measure the BER of the wanted signal at the BS receiver.
- 5) Interchange the connections of the BS Rx ports and repeat the measurements according to steps (1) to (4).

5.3.8.2 Test requirements

The BER measured according clause 5.3.8.1.2 to shall not exceed 0,001.

5.3.9 Receiver adjacent channel selectivity

5.3.9.1 Method of test

5.3.9.1.1 Initial conditions

5.3.9.1.1.1 General initial conditions

Test environment: normal; see TS 125 142 [4], clause 5.9.

RF channels to be tested: B, M and T; see clause 5.1.

5.3.9.1.1.2 3,84 Mcps TDD option

- 1) Connect an UE simulator operating at the assigned channel frequency of the wanted signal and a signal generator used to produce the interfering signal in the adjacent channel to the antenna connector of one Rx port.
- 2) Terminate or disable any other Rx port not under test.
- 3) Start transmission from the BS tester to the BS using the UL reference measurement channel (12,2 kbit/s) defined in TS 125 105 [3] annex A. The level of the UE simulator signal measured at the BS antenna connector shall be adjust to the value specified in table 15 for the Wide Area BS and table 15a for the local Area BS respectively.

- 4) Set the signal generator to produce an interfering signal that is equivalent to a continuous wideband CDMA signal with one code of chip frequency 3,84 Mchip/s, filtered by an RRC transmit pulse-shaping filter with roll-off $\alpha = 0,22$. The level of the interfering signal measured at the BS antenna connector shall be adjusted to the value specified in table 15 for the Wide Area BS and table 15a for the local Area BS respectively.

5.3.9.1.1.3 1,28 Mcps TDD option

- 1) Connect an UE simulator operating at the assigned channel frequency of the wanted signal and a signal generator used to produce the interfering signal in the adjacent channel to the antenna connector of one Rx port.
- 2) Terminate or disable any other Rx port not under test.
- 3) Start transmission from the BS tester to the BS using the UL reference measurement channel (12,2 kbit/s) defined in TS 125 105 [3], annex A. The level of the UE simulator signal measured at the BS antenna connector shall be adjusted to the value specified in table 15b for the Wide Area BS and table 15c for the local Area BS respectively.
- 4) Set the signal generator to produce an interfering signal that is equivalent to a continuous wideband CDMA signal with one code of chip frequency 1,28 Mchip/s, filtered by an RRC transmit pulse-shaping filter with roll-off $\alpha = 0,22$. The level of the interfering signal measured at the BS antenna connector shall be adjusted to the value specified in table 15b for the Wide Area BS and table 15c for the local Area BS respectively.

5.3.9.1.2 Procedure

5.3.9.1.2.1 3,84 Mcps TDD option

- 1) Set the centre frequency of the interfering signal to 5 MHz above the assigned channel frequency of the wanted signal.
- 2) Measure the BER of the wanted signal at the BS receiver.
- 3) Set the centre frequency of the interfering signal to 5 MHz below the assigned channel frequency of the wanted signal.
- 4) Measure the BER of the wanted signal at the BS receiver.
- 5) Interchange the connections of the BS Rx ports and repeat the measurements according to steps (1) to (4).

5.3.9.1.2.2 1,28 Mcps TDD option

- 1) Set the centre frequency of the interfering signal to 1,6 MHz above the assigned channel frequency of the wanted signal.
- 2) Measure the BER of the wanted signal at the BS receiver.
- 3) Set the centre frequency of the interfering signal to 1,6 MHz below the assigned channel frequency of the wanted signal.
- 4) Measure the BER of the wanted signal at the BS receiver.
- 5) Interchange the connections of the BS Rx ports and repeat the measurements according to steps (1) to (4).

5.3.9.1.3 Test requirements

The BER measured according clause 5.3.9.1.2 shall not exceed 0,001.

Annex A (normative): EN Requirements Table (EN-RT)

Notwithstanding the provisions of the copyright clause related to the text of the present document, ETSI grants that users of the present document may freely reproduce the EN-RT proforma in this annex so that it can be used for its intended purposes and may further publish the completed EN-RT.

This EN Requirements Table (EN-RT) serves a number of purposes, as follows:

- it provides a tabular summary of the requirements for this part;
- it shows the status of each EN-R, whether it is essential to implement in all circumstances (Mandatory), or whether the requirement is dependent on the supplier having chosen to support a particular optional service or functionality (Optional). In particular it enables the EN-Rs associated with a particular optional service or functionality to be grouped and identified;
- when completed in respect of a particular equipment, it provides a means to undertake the static assessment of conformity with this part the EN.

Table A.1: EN Requirements Table (EN-RT)

EN Reference		EN 301 908-7				Comment
No.	Reference	EN-R (see note)	Status			
1	4.2.2	Spectrum emission mask	M			
2	4.2.3	Transmitter adjacent channel leakage power ratio	M			
3	4.2.4	Transmitter spurious emissions	M			
4	4.2.5	Base station maximum output power	M			
5	4.2.6	Transmit intermodulation	M			
6	4.2.7	Receiver spurious emissions	M			
7	4.2.8	Receiver blocking characteristics	M			
8	4.2.9	Receiver intermodulation characteristics	M			
9	4.2.10	Receiver adjacent channel selectivity	M			

NOTE: These EN-Rs are justified under article 3.2 of the R&TTE Directive.

Key to columns:

No	Table entry number;
Reference	Clause reference number of conformance requirement within the present document;
EN-R	Title of conformance requirement within the present document;
Status	Status of the entry as follows:
M	Mandatory, shall be implemented under all circumstances;
O	Optional, may be provided, but if provided shall be implemented in accordance with the requirements;
O.n	this status is used for mutually exclusive or selectable options among a set. The integer "n" shall refer to a unique group of options within the EN-RT. A footnote to the EN-RT shall explicitly state what the requirement is for each numbered group. For example, "It is mandatory to support at least one of these options", or, "It is mandatory to support exactly one of these options".
Comments	To be completed as required.

Annex B (normative): BS configurations

B.1 Receiver Diversity

For the tests in clauses 5 of the present document, the specified test signals shall be applied to one receiver antenna connector, with the remaining receiver antenna connectors being terminated with 50 Ω .

B.2 Power Supply options

If the BS is supplied with a number of different power supply configurations, it may not be necessary to test RF parameters for each of the power supply options, provided that it can be demonstrated that the range of conditions over which the equipment is tested is at least as great as the range of conditions due to any of the power supply configurations.

This applies particularly if a BS contains a DC rail which can be supplied either externally or from an internal mains power supply. In this case, the conditions of extreme power supply for the mains power supply options can be tested by testing only the external DC supply option. The range of DC input voltages for the test should be sufficient to verify the performance with any of the power supplies, over its range of operating conditions within the BS, including variation of mains input voltage, temperature and output current.

B.3 Ancillary RF amplifiers

The requirements of the present document shall be met with the ancillary RF amplifier fitted. At tests according to clause 5 for TX and RX respectively, the ancillary amplifier is connected to the BS by a connecting network (including any cable(s), attenuator(s), etc.) with applicable loss to make sure the appropriate operating conditions of the ancillary amplifier and the BS. The applicable connecting network loss range is declared by the manufacturer. Other characteristics and the temperature dependence of the attenuation of the connecting network are neglected. The actual attenuation value of the connecting network is chosen for each test as one of the applicable extreme values. The lowest value is used unless otherwise stated.

Sufficient tests should be repeated with the ancillary amplifier fitted and, if it is optional, without the ancillary RF amplifier to verify that the BS meets the requirements of the present document in both cases.

B.4 BS using antenna arrays

A BS may be configured with a multiple antenna port connection for some or all of its TRXs or with an antenna array related to one cell (not one array per TRX). This clause applies to a BS which meets at least one of the following conditions:

- the transmitter output signals from one or more TRX appear at more than one antenna port; or
- There is more than one receiver antenna port for a TRX or per cell and an input signal is required at more than one port for the correct operation of the receiver (note that diversity reception does not meet this requirement) thus the outputs from the transmitters as well as the inputs to the receivers are directly connected to several antennas (known as "aircombining").

If a BS is used, in normal operation, in conjunction with an antenna system which contains filters or active elements which are necessary to meet the UTRA requirements, the tests of conformance may be performed on a system comprising the BS together with these elements, supplied separately for the purposes of testing. In this case, it must be demonstrated that the performance of the configuration under test is representative of the system in normal operation, and the conformance assessment is only applicable when the BS is used with the antenna system.

For testing of conformance of such a BS, the following procedure may be used.

B.4.1 Receiver tests

For each test, the test signals applied to the receiver antenna connectors shall be such that the sum of the powers of the signals applied equals the power of the test signal(s) specified in the test.

An example of a suitable test configuration is shown in figure B.1.

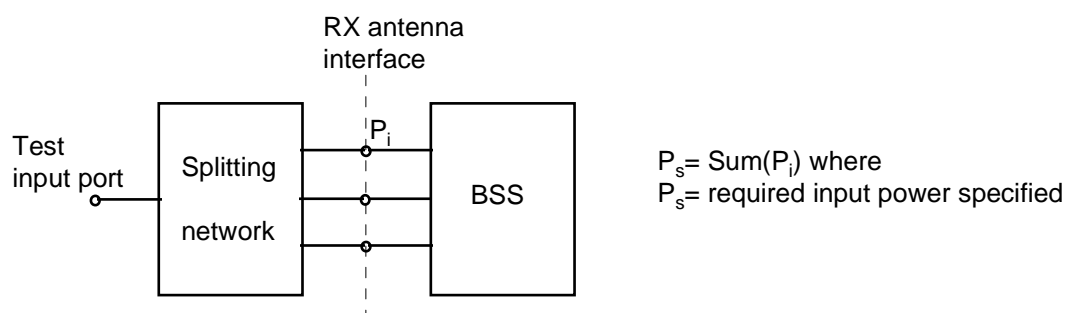

Figure B.1: Receiver test set up

For spurious emissions from the receiver antenna connector, the test may be performed separately for each receiver antenna connector.

B.4.2 Transmitter tests

For each test, the conformance requirement shall be met by the sum of the signals emitted by each transmitter antenna connector. This may be assessed by separately measuring the signals emitted by each antenna connector and summing the results, or by combining the signals and performing a single measurement. The characteristics (e.g. amplitude and phase) of the combining network should be such that the power of the combined signal is maximized.

An example of a suitable test configuration is shown in figure B.2.

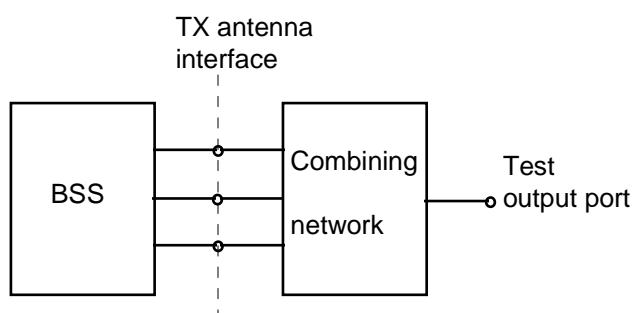

Figure B.2: Transmitter test setup

For intermodulation attenuation, the test may be performed separately for each transmitter antenna connector.

Annex C (informative): Environmental profile specification

The following environmental conditions may be declared by the supplier:

- barometric pressure: minimum and maximum;
- temperature: minimum and maximum;
- relative humidity: minimum and maximum;
- power supply: lower and upper voltage limit.

When operating outside the boundary limits of the declared operational environmental profile the equipment should not make ineffective use of the radio frequency spectrum so as to cause harmful interference.

Annex D (informative): Bibliography

- ETSI EN 301 908-1 (V1.1.1): "Electromagnetic compatibility and Radio spectrum Matters (ERM); Base Stations (BS) and User Equipment (UE) for IMT-2000 Third-Generation cellular networks; Part 1: Harmonized standard for IMT-2000, Introduction and common requirements, covering essential requirements of article 3.2 of the R&TTE Directive".
- ETSI TR 125 942: "Universal Mobile Telecommunications System (UMTS); Radio Frequency (RF) system scenarios (3GPP TR 25.942 version 6.4.0 Release 6)".
- Directive 98/34/EC of the European Parliament and of the Council of 22 June 1998 laying down a procedure for the provision of information in the field of technical standards and regulations.
- CEPT/ERC/REC 74-01E (Siófok 1998, Nice 1999, Sesimbra 2002, Hradec Kralove 2005): "Spurious Emissions".

Annex E (informative): The EN title in the official languages

Language	EN title
Czech	
Danish	Elektromagnetisk kompatibilitet og radiospektrumanliggende (ERM); Basisstationer (BS), Repeaters og brugerudstyr (UE) for IMT-2000 CDMA tredje generations cellulær radionet; Part 7: Harmoniseret EN for IMT-2000, CDMA TDD (UTRA TDD) (BS), der dækker de væsentlige krav i R&TTE Direktivets artikel 3.2
Dutch	Elektromagnetische compatibiliteit en radiospectrum-zaken (ERM); Basisstations (BS), Repeaters en gebruikersapparatuur (UE) voor IMT-2000 derde generatie mobiele netwerken; Deel 7: Geharmoniseerde EN voor IMT-2000, CDMA TDD (UTRA TDD) (BS), welke invulling geeft aan de wezenlijke vereisten, neergelegd in artikel 3.2 van de R&TTE-richtlijn
English	Electromagnetic compatibility and Radio spectrum Matters (ERM); Base Stations (BS), Repeaters and User Equipment (UE) for IMT-2000 Third-Generation cellular networks; Part 7: Harmonized EN for IMT-2000, CDMA TDD (UTRA TDD) (BS) covering essential requirements of article 3.2 of the R&TTE Directive
Estonian	
Finnish	Sähkömagneettinen yhteensopivuus ja radiospektriasiä (ERM); IMT-2000 kolmannen sukupolven solukoverkkojen tukiasemat (BS), toistimet ja matkaviestinlaitteet (UE); Osa 7: R&TTE direktiivin artiklan 3.2 olennaiset vaatimukset toteuttava yhdenmukaistettu EN IMT-2000 CDMA aikajakotekniikkaa (UTRA TDD) käyttäville tukiasemille (BS)
French	Compatibilité électromagnétique et Radioélectrique (ERM); Stations de Base (BS), Répéteurs et Equipement Utilisateur (UE) pour les réseaux cellulaires de troisième génération IMT-2000; Partie 7: Norme harmonisée pour l'IMT-2000, CDMA TDD (UTRA TDD) (BS) couvrant les exigences essentielles de l'article 3.2 de la Directive R&TTE
German	Elektromagnetische Verträglichkeit und Funkspektrumangelegenheiten (ERM); Feststationen (BS), Repeater und Einrichtungen für den Nutzer (UE) für digitale zellulare IMT-2000 Funknetze der 3. Generation, Teil 7: Harmonisierte Europäische Norm (EN) für IMT-2000, CDMA-TDD (UTRA TDD) Feststationen (BS) mit wesentlichen Anforderungen nach R&TTE-Richtlinie Artikel 3.2
Greek	Ηλεκτρομαγνητική συμβατότητα και Θέματα Ηλεκτρομαγνητικού Φάσματος (ERM); Σταθμοί Βάσης (BS), αναμεταδότες και Μηχανήματα Χρηστών (UE) για κυψελωτά δίκτυα Τρίτης Γενιάς IMT-2000; Μέρος 7- Εξαρμονισμένη τυποποίηση για IMT-2000, CDMA TDD (UTRA TDD) (BS) Που καλύπτει τα αναγκαία προαπαιτούμενα του Αρθρου 3.2 της Ντιρεκτιβας R&TTE
Hungarian	
Icelandic	
Italian	Compatibilità elettromagnetica e problematiche di Spettro Radio (ERM); Stazioni Base (BS), Ripetitori e Terminali Mobili (UE) per le reti cellulari di terza generazione IMT-2000; Parte 7: Norma armonizzata per IMT-2000, CDMA TDD (UTRA TDD) (BS) relativa ai requisiti essenziali dell'articolo 3.2 della Direttiva R&TTE
Latvian	
Lithuanian	
Maltese	
Norwegian	
Polish	
Portuguese	Assuntos de Espectro Radioeléctrico e Compatibilidade Electromagnética (ERM); Estações de Base (BS), Repetidores e equipamento de utilizador (UE) para a terceira geração de redes celulares IMT-2000; Parte 7: EN Harmonizada para o IMT-2000, CDMA TDD (UTRA-TDD) (BS), cobrindo os requisitos essenciais no âmbito do artigo 3.º, n.º 2 da Directiva R & TTE
Slovak	
Slovenian	
Spanish	Compatibilidad electromagnética y espectro radio (ERM); estaciones base (BS), Repetidores y equipos de usuario (UE) de redes móviles de tercera generación IMT-2000; Parte 7: EN armonizada que cubre los requisitos mínimos del artículo 3.2 de la directiva de R&TTE (1999/5/EC); CDMA TDD (UTRA TDD) (BS)
Swedish	Elektromagnetisk kompatibilitet och radio-spektrumfrågor (ERM); Basstationer (BS), Repeatrar och Mobilstationer (UE) för tredje generationens mobilnät IMT-2000; Del 7: Harmoniserad EN för IMT-2000, CDMA TDD (UTRA TDD) (BS) omfattande väsentliga krav enligt artikel 3.2 i R&TTE-direktivet

History

Document history		
V1.1.1	January 2002	Publication
V2.2.1	October 2003	Publication
V3.0.0	June 2006	Public Enquiry PE 20061020: 2006-06-21 to 2006-10-20