



**IMT cellular networks;
Harmonized EN covering the essential requirements
of article 3.2 of the R&TTE Directive;
Part 3: CDMA Direct Spread (UTRA FDD) Base Stations (BS)**

Reference

REN/MSG-TFES-011-03

Keywords

3G, 3GPP, cellular, digital, E-UTRA, IMT,
IMT-Advanced, LTE, mobile, radio, regulation,
UMTS, WCDMA

ETSI

650 Route des Lucioles
F-06921 Sophia Antipolis Cedex - FRANCE

Tel.: +33 4 92 94 42 00 Fax: +33 4 93 65 47 16

Siret N° 348 623 562 00017 - NAF 742 C
Association à but non lucratif enregistrée à la
Sous-Préfecture de Grasse (06) N° 7803/88

Important notice

The present document can be downloaded from:

<http://www.etsi.org>

The present document may be made available in electronic versions and/or in print. The content of any electronic and/or print versions of the present document shall not be modified without the prior written authorization of ETSI. In case of any existing or perceived difference in contents between such versions and/or in print, the only prevailing document is the print of the Portable Document Format (PDF) version kept on a specific network drive within ETSI Secretariat.

Users of the present document should be aware that the document may be subject to revision or change of status. Information on the current status of this and other ETSI documents is available at

<http://portal.etsi.org/tb/status/status.asp>

If you find errors in the present document, please send your comment to one of the following services:

http://portal.etsi.org/chaicor/ETSI_support.asp

Copyright Notification

No part may be reproduced or utilized in any form or by any means, electronic or mechanical, including photocopying and microfilm except as authorized by written permission of ETSI.

The content of the PDF version shall not be modified without the written authorization of ETSI.

The copyright and the foregoing restriction extend to reproduction in all media.

© European Telecommunications Standards Institute 2015.

All rights reserved.

DECT™, **PLUGTESTS™**, **UMTS™** and the ETSI logo are Trade Marks of ETSI registered for the benefit of its Members. **3GPP™** and **LTE™** are Trade Marks of ETSI registered for the benefit of its Members and of the 3GPP Organizational Partners.
GSM® and the GSM logo are Trade Marks registered and owned by the GSM Association.

Contents

Intellectual Property Rights	6
Foreword.....	6
Modal verbs terminology.....	6
Introduction	6
1 Scope	7
2 References	7
2.1 Normative references	7
2.2 Informative references.....	8
3 Definitions, symbols and abbreviations	9
3.1 Definitions	9
3.2 Symbols.....	11
3.3 Abbreviations	12
4 Technical requirements specifications	13
4.1 Environmental profile.....	13
4.2 Conformance requirements	13
4.2.1 Introduction.....	13
4.2.2 Spectrum emissions mask	16
4.2.2.1 Definition	16
4.2.2.2 Limit.....	16
4.2.2.3 Conformance.....	23
4.2.3 Adjacent channel leakage power ratio (ACLR).....	24
4.2.3.1 Definition	24
4.2.3.2 Limits	24
4.2.3.3 Cumulative ACLR test requirement in non-contiguous spectrum or multiple-bands	25
4.2.3.4 Conformance.....	26
4.2.4 Transmitter spurious emissions.....	26
4.2.4.1 Definition	26
4.2.4.2 Limits	26
4.2.4.2.1 Spurious emissions	26
4.2.4.2.2 Co-existence with other systems	27
4.2.4.2.3 Co-existence with services in adjacent frequency bands	28
4.2.4.2.4 Protection of the BS receiver of own or different BS	28
4.2.4.2.5 Co-existence with Home BS operating in other bands	30
4.2.4.3 Conformance.....	30
4.2.5 Base Station maximum output power	30
4.2.5.1 Definition	30
4.2.5.2 Limit.....	30
4.2.5.3 Conformance.....	31
4.2.6 Transmitter intermodulation	31
4.2.6.1 Definition	31
4.2.6.2 Limit.....	32
4.2.6.3 Conformance.....	32
4.2.7 Receiver spurious emissions	32
4.2.7.1 Definition	32
4.2.7.2 Limit.....	32
4.2.7.3 Conformance.....	32
4.2.8 Blocking characteristics	33
4.2.8.1 Definition	33
4.2.8.2 Limit.....	33
4.2.8.3 Conformance.....	37
4.2.9 Receiver intermodulation characteristics	37
4.2.9.1 Definition	37
4.2.9.2 Limit.....	38

4.2.9.3	Conformance	39
4.2.10	Receiver adjacent channel selectivity	39
4.2.10.1	Definition	39
4.2.10.2	Limit	39
4.2.10.3	Conformance	40
4.2.11	Home BS output power for adjacent channel protection	40
4.2.11.1	Definition	40
4.2.11.2	Limit	40
4.2.11.3	Conformance	41
5	Testing for compliance with technical requirements	41
5.1	Environmental conditions for testing	41
5.2	Interpretation of the measurement results	41
5.3	Essential radio test suites	43
5.3.0	Introduction	43
5.3.1	Spectrum emission mask	43
5.3.1.0	General	43
5.3.1.1	Initial conditions	43
5.3.1.2	Procedures	44
5.3.2	Adjacent Channel Leakage power Ratio (ACLR)	44
5.3.2.1	Initial conditions	44
5.3.2.2	Procedure	45
5.3.3	Transmitter spurious emissions	45
5.3.3.0	General	45
5.3.3.1	Initial conditions	45
5.3.3.2	Procedure	46
5.3.4	Base Station maximum output power	46
5.3.4.0	General	46
5.3.4.1	Initial conditions	46
5.3.4.2	Procedure	46
5.3.5	Transmit intermodulation	47
5.3.5.0	General	47
5.3.5.1	Initial conditions	47
5.3.5.2	Procedures	47
5.3.6	Receiver spurious emissions	48
5.3.6.0	General	48
5.3.6.1	Initial conditions	48
5.3.6.2	Procedure	48
5.3.7	Blocking characteristics	49
5.3.7.0	General	49
5.3.7.1	Initial conditions	49
5.3.7.2	Procedure	50
5.3.8	Receiver intermodulation characteristics	50
5.3.8.0	General	50
5.3.8.1	Initial conditions	50
5.3.8.2	Procedures	50
5.3.9	Adjacent Channel Selectivity (ACS)	51
5.3.9.0	General	51
5.3.9.1	Initial conditions	51
5.3.9.2	Procedure	51
5.3.10	Home BS output power for adjacent channel protection	52
5.3.10.1	Initial conditions	52
5.3.10.2	Procedure	52
Annex A (normative):	HS Requirements and conformance Test specifications Table (HS-RTT)	54
Annex B (normative):	Base Station configurations	56
B.1	Receiver diversity	56
B.2	Duplexers	56

B.3	Power supply options	56
B.4	Ancillary RF amplifiers.....	57
B.5	BS using antenna arrays	57
B.5.0	Introduction	57
B.5.1	Receiver tests.....	58
B.5.2	Transmitter tests	58
B.6	Transmit diversity and MIMO transmission	58
B.7	BS with integrated Iuant BS modem.....	59
Annex C (informative):	Environmental profile specification	60
Annex D:	Void	61
Annex E (informative):	Bibliography.....	62
History		63

Intellectual Property Rights

IPRs essential or potentially essential to the present document may have been declared to ETSI. The information pertaining to these essential IPRs, if any, is publicly available for **ETSI members and non-members**, and can be found in ETSI SR 000 314: *"Intellectual Property Rights (IPRs); Essential, or potentially Essential, IPRs notified to ETSI in respect of ETSI standards"*, which is available from the ETSI Secretariat. Latest updates are available on the ETSI Web server (<http://ipr.etsi.org>).

Pursuant to the ETSI IPR Policy, no investigation, including IPR searches, has been carried out by ETSI. No guarantee can be given as to the existence of other IPRs not referenced in ETSI SR 000 314 (or the updates on the ETSI Web server) which are, or may be, or may become, essential to the present document.

Foreword

This draft Harmonized European Standard (EN) has been produced by ETSI Technical Committee Mobile Standards Group (MSG), and is now submitted for the combined Public Enquiry and Vote phase of the ETSI standards EN Approval Procedure.

The present document has been produced by ETSI in response to mandates M/284 and M/406 issued from the European Commission under Directive 98/34/EC [i.1] as amended by Directive 98/48/EC [i.7].

The title and reference to the present document are intended to be included in the publication in the Official Journal of the European Union of titles and references of Harmonized Standard under the Directive 1999/5/EC [i.2].

The requirements relevant to Directive 1999/5/EC [i.2] are summarized in annex A.

The present document is part 3 of a multi-part deliverable. Full details of the entire series can be found in part 1 [i.5].

Proposed national transposition dates	
Date of latest announcement of this EN (doa):	3 months after ETSI publication
Date of latest publication of new National Standard or endorsement of this EN (dop/e):	6 months after doa
Date of withdrawal of any conflicting National Standard (dow):	18 months after doa

Modal verbs terminology

In the present document **"shall"**, **"shall not"**, **"should"**, **"should not"**, **"may"**, **"may not"**, **"need"**, **"need not"**, **"will"**, **"will not"**, **"can"** and **"cannot"** are to be interpreted as described in clause 3.2 of the [ETSI Drafting Rules](#) (Verbal forms for the expression of provisions).

"must" and **"must not"** are **NOT** allowed in ETSI deliverables except when used in direct citation.

Introduction

The present document is part of a set of standards developed by ETSI and is designed to fit in a modular structure to cover all radio and telecommunications terminal equipment within the scope of the R&TTE Directive [i.2]. The modular structure is shown in ETSI EG 201 399 [i.3].

1 Scope

The present document applies to the following {radio}{telecommunications terminal} equipment types:

- 1) Stations for IMT 2000 CDMA Direct Spread (UTRA FDD).

This radio equipment type is capable of operating in all or any part of the frequency bands given in table 1-1.

Table 1-1: UTRA FDD Base Station operating bands

UTRA FDD band	Direction of transmission	UTRA FDD Base Station operating bands
I	Transmit	2 110 MHz to 2 170 MHz
	Receive	1 920 MHz to 1 980 MHz
III	Transmit	1 805 MHz to 1 880 MHz
	Receive	1 710 MHz to 1 785 MHz
VII	Transmit	2 620 MHz to 2 690 MHz
	Receive	2 500 MHz to 2 570 MHz
VIII	Transmit	925 MHz to 960 MHz
	Receive	880 MHz to 915 MHz
XV	Transmit	2 600 MHz to 2 620 MHz
	Receive	1 900 MHz to 1 920 MHz
XVI	Transmit	2 585 MHz to 2 600 MHz
	Receive	2 010 MHz to 2 025 MHz
XX	Transmit	791 MHz to 821 MHz
	Receive	832 MHz to 862 MHz
XXII	Transmit	3 510 MHz to 3 590 MHz
	Receive	3 410 MHz to 3 490 MHz
XXXII (see note)	Transmit	1 452 MHz to 1 492 MHz
	Receive	-
NOTE: The down link frequenc(ies) of this band are paired with the uplink frequenc(ies) of the other FDD band (external) of the dual band configuration.		

The present document covers requirements for UTRA FDD Base Stations for 3GPP Releases 99, 4, 5, 6, 7, 8, 9, 10 and 11. This includes the requirements for BS operating bands from 3GPP Release 12. In addition, the present document covers requirements for UTRA FDD Base Stations in the operating bands specified in ETSI TS 102 735 [i.4].

The present document is intended to cover the provisions of Directive 1999/5/EC [i.2] (R&TTE Directive), Article 3.2, which states that "..... radio equipment shall be so constructed that it effectively uses the spectrum allocated to terrestrial/space radio communications and orbital resources so as to avoid harmful interference".

In addition to the present document, other ENs that specify technical requirements in respect of essential requirements under other parts of article 3 of the R&TTE Directive may apply to equipment within the scope of the present document.

NOTE: A list of such ENs is included on the web site <http://www.newapproach.org>.

2 References

2.1 Normative references

References are either specific (identified by date of publication and/or edition number or version number) or non-specific. For specific references, only the cited version applies. For non-specific references, the latest version of the reference document (including any amendments) applies.

Referenced documents which are not found to be publicly available in the expected location might be found at <http://docbox.etsi.org/Reference>.

NOTE: While any hyperlinks included in this clause were valid at the time of publication, ETSI cannot guarantee their long term validity.

The following referenced documents are necessary for the application of the present document.

- [1] Void.
- [2] ETSI TS 125 141 (V11.10.0) (01-2015): "Universal Mobile Telecommunications System (UMTS); Base Station (BS) conformance testing (FDD) (3GPP TS 25.141 version 11.10.0 Release 11)".
- [3] Recommendation ITU-R SM.329-12 (09-2012): "Unwanted emissions in the spurious domain".
- [4] Recommendation ITU-T O.153 (10-1992): "Basic parameters for the measurement of error performance at bit rates below the primary rate".
- [5] ETSI TS 136 104 (V11.11.0) (01-2015): "LTE; Evolved Universal Terrestrial Radio Access (E-UTRA); Base Station (BS) radio transmission and reception (3GPP TS 36.104 version 11.11.0 Release 11)".
- [6] ETSI TS 145 004 (V11.0.0) (10-2012): "Digital cellular telecommunications system (Phase 2+); Modulation (3GPP TS 45.004 version 11.0.0 Release 11)".
- [7] Void.
- [8] Void.
- [9] ETSI TS 125 104 (V11.10.0) (01-2015): "Universal Mobile Telecommunications System (UMTS); Base Station (BS) radio transmission and reception (FDD) (3GPP TS 25.104 version 11.10.0 Release 11)".

2.2 Informative references

References are either specific (identified by date of publication and/or edition number or version number) or non-specific. For specific references, only the cited version applies. For non-specific references, the latest version of the reference document (including any amendments) applies.

NOTE: While any hyperlinks included in this clause were valid at the time of publication, ETSI cannot guarantee their long term validity.

The following referenced documents are not necessary for the application of the present document but they assist the user with regard to a particular subject area.

- [i.1] Directive 98/34/EC of the European Parliament and of the Council of 22 June 1998 laying down a procedure for the provision of information in the field of technical standards and regulations.
- [i.2] Directive 1999/5/EC of the European Parliament and of the Council of 9 March 1999 on radio equipment and telecommunications terminal equipment and the mutual recognition of their conformity (R&TTE Directive).
- [i.3] ETSI EG 201 399: "Electromagnetic compatibility and Radio spectrum Matters (ERM); A guide to the production of Harmonized Standards for application under the Radio Equipment Directive".
- [i.4] ETSI TS 102 735 (V7.1.0): "Universal Mobile Telecommunications System (UMTS); Band-specific requirements for UMTS Frequency Division Duplex (FDD) operation in the bands 1 900 MHz to 1 920 MHz paired with 2 600 MHz to 2 620 MHz and 2 010 MHz to 2 025 MHz paired with 2 585 MHz to 2 600 MHz".
- [i.5] ETSI EN 301 908-1 (V7.1.1) (09-2014): "IMT cellular networks; Harmonized EN covering the essential requirements of article 3.2 of the R&TTE Directive; Part 1: Introduction and common requirements".

- [i.6] ETSI TR 100 028 (all parts): "Electromagnetic compatibility and Radio spectrum Matters (ERM); Uncertainties in the measurement of mobile radio equipment characteristics".
- [i.7] Directive 98/48/EC of the European Parliament and of the Council of 20 July 1998 amending Directive 98/34/EC laying down a procedure for the provision of information in the field of technical standards and regulations.
- [i.8] ETSI EN 301 908-18 (V7.1.2) (07-2014): "IMT cellular networks; Harmonized EN covering the essential requirements of article 3.2 of the R&TTE Directive; Part 18: E-UTRA, UTRA and GSM/EDGE Multi-Standard Radio (MSR) Base Station (BS)".
- [i.9] CEPT ECC Decision (13)03: "The harmonised use of the frequency band 1452-1492 MHz for Mobile/Fixed Communications Networks Supplemental Downlink (MFCN SDL)".

3 Definitions, symbols and abbreviations

3.1 Definitions

For the purposes of the present document, the following terms and definitions apply:

ancillary equipment: equipment (apparatus) used in connection with a Base Station

NOTE: This is considered as an ancillary equipment (apparatus) if:

- the equipment is intended for use in conjunction with a BS to provide additional operational and/or control features to the radio equipment, (e.g. to extend control to another position or location);
- the equipment cannot be used on a standalone basis to provide user functions independently of a BS; and
- the BS to which it is connected, is capable of providing some intended operation such as transmitting and/or receiving without the ancillary equipment (i.e. it is not a sub-unit of the main equipment essential to the main equipment basic functions).

Base Station class: wide area Base Station, medium range Base Station, local area Base Station or home Base Station, as declared by the manufacturer

BS RF bandwidth: bandwidth in which a Base Station transmits and/or receives multiple carriers simultaneously within each supported operating band

BS RF bandwidth edge: frequency of one of the edges of the Base Station RF bandwidth

chip rate: rate of "chips" (modulated symbols after spreading) per second

NOTE: The UTRA FDD chip rate is 3,84 Mchip/s.

contiguous spectrum: spectrum consisting of a contiguous block of spectrum with no sub-block gap(s)

downlink operating band: part of the operating band designated for downlink (BS transmit)

environmental profile: range of environmental conditions under which equipment, within the scope of the present document, is required to comply with the provisions of the present document

highest carrier: carrier with the highest carrier centre frequency transmitted/received in the specified operating band(s)

home Base Station: base station characterized by requirements derived from femtocell scenarios

inter-RF bandwidth gap: frequency gap between two consecutive RF bandwidths that are placed within two supported operating bands

local area Base Station: base station characterized by requirements derived from picocell scenarios with a BS to UE minimum coupling loss equal to 45 dB

lower edge: lowest frequency in the Base station RF bandwidth, or the lowest frequency in the channel bandwidth of a single E-UTRA carrier, used as a frequency reference point for transmitter and receiver requirements

lower sub-block edge: frequency at the lower edge of one sub-block

NOTE: It is used as a frequency reference point for both transmitter and receiver requirements.

lowest carrier: carrier with the lowest carrier centre frequency transmitted/received in the specified operating band(s)

maximum BS RF bandwidth: maximum RF bandwidth supported by a BS within each supported operating band

maximum output power per carrier: mean power level per carrier of the Base Station measured at the antenna connector in a specified reference condition

maximum radio bandwidth: maximum frequency difference between the upper edge of the highest used carrier and the lower edge of the lowest used carrier

mean power: power (transmitted or received) in a bandwidth of at least $(1 + \alpha)$ times the chip rate of the radio access mod, when applied to a WCDMA-modulated signal

NOTE 1: The period of measurement is at least one timeslot unless otherwise stated.

NOTE 2: $\alpha = 0,22$ is the roll-off factor of the WCDMA signal.

medium range Base Station: base station characterized by requirements derived from microcell scenarios with a BS to UE minimum coupling loss equal to 53 dB

MIMO mode: downlink MIMO configuration with two transmit antennas

MIMO mode with four transmit antennas: downlink MIMO configuration with four transmit antennas

multi-band Base Station: base station characterized by the ability of its transmitter and/or receiver to process two or more carriers in common active RF components simultaneously, where at least one carrier is configured at a different non-overlapping operating band than the other carrier(s)

multi-band receiver: receiver characterized by the ability to process two or more carriers in common active RF components simultaneously, where at least one carrier is configured at a different non-overlapping operating band than the other carrier(s)

multi-band transmitter: transmitter characterized by the ability to process two or more carriers in common active RF components simultaneously, where at least one carrier is configured at a different non-overlapping operating band than the other carrier(s)

multi-carrier transmission configuration: set of one or more contiguous or non-contiguous carriers that a BS is able to transmit simultaneously according to the manufacturer's specification

non-contiguous spectrum: spectrum consisting of two or more sub-blocks separated by sub-block gap(s)

operating band: frequency range that is defined with a specific set of technical requirements, in which UTRA FDD operates

NOTE: The operating band(s) for a UTRA FDD BS is declared by the manufacturer according to the designations in table 1-1. Operating bands for UTRA are designated with Roman numerals, while the corresponding operating bands for E-UTRA are designated with Arabic numerals.

output power: mean power of one carrier of the Base Station, delivered to a load with resistance equal to the nominal load impedance of the transmitter

rated output power: rated output power of the Base Station is the mean power level per carrier that the manufacturer has declared to be available at the antenna connector

rated total output power: rated total output power of the Base Station is the mean power level that the manufacturer has declared to be available at the antenna connector

RRC filtered mean power: mean power as measured through a root raised cosine filter with roll-off factor α and a bandwidth equal to the chip rate of the radio access mode

NOTE: The RRC filtered mean power of a perfectly modulated WCDMA signal is 0,246 dB lower than the mean power of the same signal.

sub-block: one contiguous allocated block of spectrum for use by the same Base Station

NOTE: There may be multiple instances of sub-blocks within an RF bandwidth.

sub-block bandwidth: bandwidth of one sub-block

sub-block gap: frequency gap between two consecutive sub-blocks within an RF bandwidth, where the RF requirements in the gap are based on co-existence for un-coordinated operation

total RF bandwidth: maximum sum of RF bandwidths in all supported operating bands

uplink operating band: part of the operating band designated for uplink (BS receive)

upper edge: highest frequency in the BS RF Bandwidth or the highest frequency in the channel bandwidth of a single UTRA carrier; used as a frequency reference point for transmitter and receiver requirements

upper sub-block edge: frequency at the higher edge of one sub-block. It is used as a frequency reference point for both transmitter and receiver requirements

wide area Base Station: Base Station characterized by requirements derived from Macro Cell scenarios with a BS to UE minimum coupling loss equal to 70 dB

NOTE: This Base Station class has the same requirements as the general purpose Base Station in Releases 99, 4 and 5.

3.2 Symbols

For the purposes of the present document, the following symbols apply:

Δf	Separation between the carrier centre frequency and the nominal -3 dB point of the measuring filter closest to the carrier frequency
Δf_{\max}	The largest value of Δf used for defining the requirement
B	Appropriate frequency in the Bottom of the operating band of the BS
CPICH \hat{E}_c	Common Pilot Channel code power (on the adjacent channel)
F_{filter}	Filter centre frequency
F_{high}	The highest BS transmit frequency of the downlink operating band
F_{low}	The lowest BS transmit frequency of the downlink operating band
F_{uw}	Frequency of unwanted signal
I_{oh}	Total received power density excluding own Home BS signal
$P_{\text{EM},N}$	Declared emission level for channel N
P_{max}	Maximum output power (per carrier)
α	Roll-off factor
B_{RFBW}	Maximum BS RF bandwidth located at the bottom of the supported frequency range in each operating band
E_b	Average energy per information bit for the PCCPCH, SCCPCH and DPCH, at the antenna connector
E_c	Average energy per PN chip
f	Frequency
Δf	Separation between the channel edge frequency and the nominal -3 dB point of the measuring filter closest to the carrier frequency
F_{offset}	Frequency offset from the centre frequency of the <i>highest</i> transmitted/received carrier to the <i>upper</i> RF bandwidth edge or sub-block edge, or from the centre frequency of the <i>lowest</i> transmitted/received carrier to the <i>lower</i> RF bandwidth edge or sub-block edge

NOTE: F_{offset} for UTRA FDD is 2,5 MHz.

F_{DL_low}	The lowest frequency of the downlink operating band
F_{DL_high}	The highest frequency of the downlink operating band
F_{DL_Offset}	The offset parameter used to calculate the UARFCN
F_{UL_low}	The lowest frequency of the uplink operating band
F_{UL_high}	The highest frequency of the uplink operating band
F_{UL_Offset}	The offset parameter used to calculate the UARFCN
M	Appropriate frequency in the Middle of the operating band of the BS
M_{RFBW}	Maximum BS RF bandwidth located in the middle of the supported frequency range in each operating band
$P_{EM,N}$	Declared emission level for channel N
$P_{EM,B32,ind}$	Declared emission level in Band 32, ind=a, b, c, d, e
PRAT	Rated output power (per carrier)
Prated,t	Rated total output power
Pout	Output power
$P_{REFSENS}$	Reference sensitivity power level
RX	Receiver
T	Appropriate frequency in the Top of the operating band of the BS
T_{RFBW}	Maximum BS RF bandwidth located at the top of the supported frequency range in each operating band
Tx	Transmitter
W_{gap}	Sub-block gap or inter RF bandwidth gap size

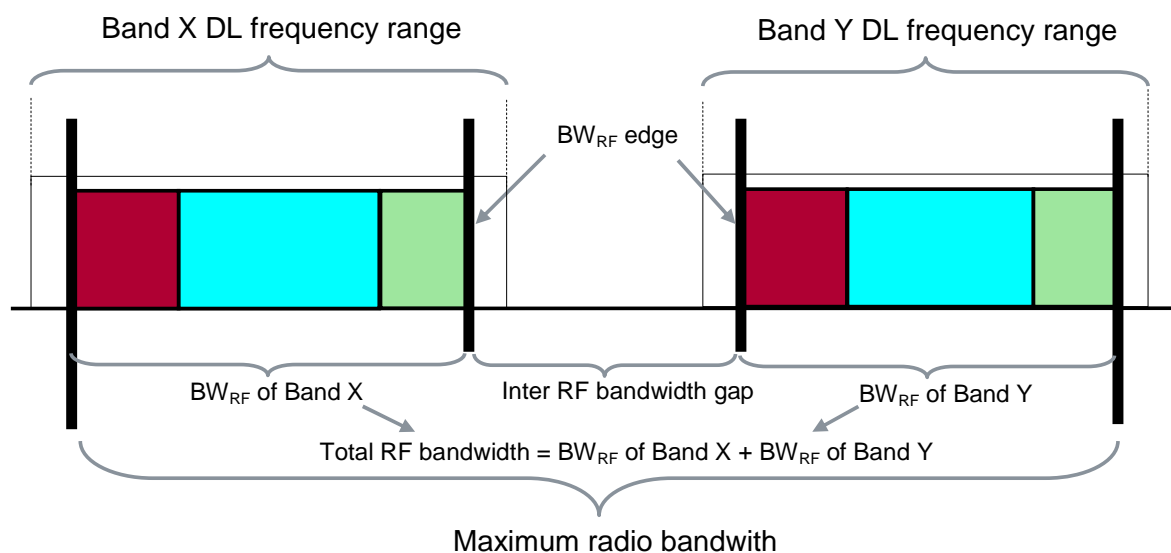

Figure 3.2-1: Illustration of maximum radio bandwidth and Total RF bandwidth for Multi-band Base Station

3.3 Abbreviations

For the purposes of the present document, the following abbreviations apply:

ACLR	Adjacent Channel Leakage power Ratio
ACS	Adjacent Channel Selectivity
AWGN	Additive White Gaussian Noise
BER	Bit Error Ratio
BS	Base Station
BTS	Base Transceiver Station
CACLR	Cumulative ACLR
CDMA	Code Division Multiple Access
CPICH	Common Pilot Channel
CW	Continuous Wave
DC	Direct Current

DL	Down Link (forward link)
DTT	Digital Terrestrial Television
DUT	Device Under Test
EIRP	Effective Isotropic Radiated Power
EMC	ElectroMagnetic Compatibility
EUT	Equipment Under Test
FDD	Frequency Division Duplexing
GMSK	Gaussian Minimum Shift Keying
GSM	Global System for Mobile communications
HSDPA	High Speed Downlink Packet Access
IMT	International Mobile Telecommunications
MC	Multi-Carrier
MIMO	Multiple Input Multiple Output
MS	Mobile Station
MSR	Multi-Standard Radio
NC	Non-Contiguous
PCCPCH	Primary Common Control Physical Channel
R&TTE	Radio and Telecommunications Terminal Equipment
RAT	Radio Access Technology
RBW	Resolution BandWidth (of test equipment)
RF	Radio Frequency
RMS	Root Mean Square
RRC	Root-Raised Cosine
SC	Single Carrier
SCCPCH	Secondary Common Control Physical CHannel
TDD	Time Division Duplexing
UARFCN	UTRA Absolute Radio Frequency Channel Number
UE	User Equipment
UL	Up Link (reverse link)
UMTS	Universal Mobile Telecommunications System
UTRA	Universal Terrestrial Radio Access
WCDMA	Wideband Code Division Multiple Access

4 Technical requirements specifications

4.1 Environmental profile

The technical requirements of the present document apply under the environmental profile for operation of the equipment, which shall be declared by the supplier. The equipment shall comply with all the technical requirements of the present document at all times when operating within the boundary limits of the declared operational environmental profile.

For guidance on how a supplier can declare the environmental profile, see annex C.

4.2 Conformance requirements

4.2.1 Introduction

The requirements in the present document are based on the assumption that the operating band (see table 1-1) is shared between systems of the IMT family (for band III and VIII also GSM) or systems having compatible characteristics.

To meet the essential requirement under article 3.2 of Directive 1999/5/EC [i.2] (R&TTE Directive) for IMT Base Stations (BS), seven essential parameters in addition to those in ETSI EN 301 908-1 [i.5] have been identified. Table 4.2.1-1 provides a cross reference between these seven essential parameters and the corresponding ten technical requirements for equipment within the scope of the present document.

Table 4.2.1-1: Cross references

Essential parameter	Corresponding technical requirements
Spectrum emissions mask	4.2.2 Spectrum emissions mask
	4.2.3 Adjacent Channel Leakage power Ratio (ACLR)
	4.2.11 Home BS output power for adjacent channel protection
Conducted spurious emissions from the transmitter antenna connector	4.2.4 Transmitter spurious emissions
Accuracy of maximum output power	4.2.5 Base Station maximum output power
Intermodulation attenuation of the transmitter	4.2.6 Transmit intermodulation
Conducted spurious emissions from the receiver antenna connector	4.2.7 Receiver spurious emissions
Impact of interference on receiver performance	4.2.8 Blocking characteristics
	4.2.9 Receiver intermodulation characteristics
Receiver adjacent channel selectivity	4.2.10 Receiver Adjacent Channel Selectivity (ACS)

NOTE: There are EC and ECC Decisions for the harmonization of certain frequency bands for terrestrial systems capable of providing electronic communications services, including technical conditions and parameters related to spectrum usage of the bands. These are related to the deployment and installation of the equipment, but are not related to the conformity of the equipment with the present document.

The supplier shall declare the following:

- The operating band(s) supported by the Base Station according to table 1-1.
- The supported RF configurations according to clause 4.11.6 in ETSI TS 125 141 [2].

The technical requirements in the present document apply for Base Stations supporting UTRA FDD, for the declared Base Station class and operating band(s) as outlined for each requirement. For a Base Station supporting more than one operating band, conformance testing for each technical requirement in clause 5 shall be performed for each operating band.

When the BS is configured to receive multiple carriers, all the BER requirements are applicable for each received carrier. For ACS, blocking and intermodulation characteristics, the negative offsets of the interfering signal apply relative to the lower edge and positive offsets of the interfering signal apply relative to the higher edge.

For BS capable of multi-band operation, the technical requirements in present clause shall apply for each supported operating band unless otherwise stated. For some requirements it is explicitly stated that specific additions or exclusions to the requirement apply for BS capable of multi-band operation.

For BS capable of multi-band operation, various structures in terms of combinations of different transmitter and receiver implementations (multi-band or single-band) with mapping of transceivers to one or more antenna port(s) in different ways are possible. In the case where multiple bands are mapped on separate antenna connectors, the following apply:

- Single-band ACLR, spectrum emission mask, transmitter spurious emissions, transmitter intermodulation and receiver spurious emissions requirements shall apply to each antenna connector.
- If the BS is configured for single-band operation, single-band requirements shall apply to the antenna connector configured for single-band operation and no exclusions or provisions for multi-band capable BS are applicable. Single-band requirements are tested separately at the antenna connector configured for single-band operation, with all other antenna connectors terminated.

A spectrum allocation where the BS operates can either be contiguous or non-contiguous. Unless otherwise stated, the requirements in the present document apply for BS configured for both contiguous spectrum operation and non-contiguous spectrum operation.

For BS operation in non-contiguous spectrum, some requirements apply also inside the sub-block gaps. For each such requirement, it is stated how the limits apply relative to the sub-block edges.

The technical requirements also apply to the BS configurations described in annex B.

For an UTRA FDD BS additionally conforming to ETSI EN 301 908-18 [i.8], conformance with the technical requirements listed in table 4.2.1-1 can equally be demonstrated through the corresponding technical requirements and test suites in ETSI EN 301 908-18 [i.8], as listed in table 4.2.1-2.

When conformance is demonstrated through the test suites in ETSI EN 301 908-18 [i.8] for these technical requirements, the corresponding test suites in the present document need not be performed.

Table 4.2.1-2: Alternative technical requirements and test suites in ETSI EN 301 908-18 [i.8] that can equally be used for demonstrating BS conformance

Technical requirement in the present document	Corresponding technical requirements in ETSI EN 301 908-18 [i.8]	Corresponding test suites in ETSI EN 301 908-18 [i.8]
4.2.2 Spectrum emissions mask	4.2.2 Operating band unwanted emissions	5.3.1 Operating band unwanted emissions
4.2.3 Adjacent Channel Leakage power Ratio (ACLR)	See note	See note
4.2.4 Transmitter spurious emissions	4.2.4 Transmitter spurious emissions	5.3.3 Transmitter spurious emissions
4.2.5 Base Station maximum output power	4.2.5 Base station maximum output power	5.3.4 Base station maximum output power
4.2.6 Transmit intermodulation	4.2.6 Transmit intermodulation	5.3.5 Transmit intermodulation
4.2.7 Receiver spurious emissions	4.2.7 Receiver spurious emissions	5.3.6 Receiver spurious emissions
4.2.8 Blocking characteristics	4.2.8 In-band blocking	5.3.7 In-band blocking
	4.2.9 Out-of-band blocking	5.3.8 Out-of-band blocking
4.2.9 Receiver intermodulation characteristics	4.2.10 Receiver intermodulation characteristics	5.3.9 Receiver intermodulation characteristics
4.2.10 Receiver adjacent channel selectivity	4.2.11 Narrowband blocking	5.3.10 Narrowband blocking
NOTE: Conformance with the UTRA ACLR requirement is for an MSR BS demonstrated through the requirement in clause 4.2.3 of the present document and the corresponding test suite in clause 5.3.2.		

For ACS, blocking and intermodulation characteristics, the negative offsets of the interfering signal apply relative to the assigned channel frequency of the lowest carrier frequency received and positive offsets of the interfering signal apply relative to the assigned channel frequency of the highest carrier frequency received.

For a BS declared to support Band XX, the manufacturer shall additionally declare the following quantities associated with the applicable test conditions of table 4.2.2.2-7 and information in annex D of ETSI TS 125 104 [9]:

$P_{EM,N}$ Declared emission level for channel N.

P_{10MHz} Maximum output Power in 10 MHz.

UTRA is designed to operate in the following multi-carrier and band combinations:

Table 4.2.1-3: Dual-Band Dual-Carrier HSDPA (DB-DC-HSDPA) configurations

DB-DC-HSDPA Configuration	UL Band	DL Bands
1	I or VIII	I and VIII
6	I	I and XXXII

Table 4.2.1-4: Single-band 4-Carrier HSDPA (4C-HSDPA) configurations

Single-band 4C-HSDPA Configuration	Operating Band	Number of DL carriers
I-3	I	3
NOTE: Single-band 4C-HSDPA configuration is numbered as (X-M) where X denotes the operating band and M denotes the number of DL carriers.		

Table 4.2.1-5: Dual band 4-Carrier HSDPA (DB-4C-HSDPA) configurations

Dual band 4C-HSDPA Configuration	UL Band	DL Band A	Number of DL carriers in Band A	DL Band B	Number of DL carriers in Band B
I-2-VIII-1	I or VIII	I	2	VIII	1
I-3-VIII-1	I or VIII	I	3	VIII	1
I-2-VIII-2	I or VIII	I	2	VIII	2
I-1-VIII-2	I or VIII	I	1	VIII	2
I-1-XXXII-2	I	I	1	XXXII	2
I-2-XXXII-1	I	I	2	XXXII	1

NOTE: Dual band 4C-HSDPA configuration is numbered as (X-M-Y-N) where X denotes the DL Band A, M denotes the number DL carriers in the DL Band A, Y denotes the DL Band B, and N denotes the number of DL carriers in the DL Band B.

Table 4.2.1-6: Single-band 8C-HSDPA configurations

Single-band 8C-HSDPA Configuration	Operating Band	Number of DL carriers
I-8	I	8

NOTE: Single-band 8C-HSDPA configuration is numbered as (X-M) where X denotes the operating band and M denotes the number of DL carriers.

UTRA is designed to operate in the following non-contiguous spectrum operation configurations.

Table 4.2.1-7: Single-band non-contiguous 4C-HSDPA (NC-4C-HSDPA) configurations

Single-band NC-4C-HSDPA Configuration	Operating Band	Number of DL carriers in one sub-block	Sub-block gap [MHz]	Number of DL carriers in the other sub-block
I-1-5-1	I	1	5	1
I-2-5-1	I	2	5	1
I-3-10-1	I	3	10	1

NOTE: Single-band NC-4C-HSDPA configuration is numbered as (X-M-Y-N) where X denotes the operating band, M denotes the number of DL carriers in one sub-block, Y denotes the sub-block gap in MHz and N denotes the number of DL carriers in the other sub-block. M and N can be switched.

4.2.2 Spectrum emissions mask

4.2.2.1 Definition

Out-of-band emissions are unwanted emissions immediately outside the channel bandwidth resulting from the modulation process and non-linearity in the transmitter but excluding spurious emissions. This out-of-band emission limit is specified in terms of a spectrum emission mask and adjacent channel leakage power ratio for the transmitter.

For a UTRA FDD BS additionally conforming to ETSI EN 301 908-18 [i.8], either the requirement of the present clause or the Operating band unwanted emissions requirement in clause 4.2.2 of ETSI EN 301 908-18 [i.8] can be equally applied, as listed in table 4.2.1-2.

4.2.2.2 Limit

The requirement shall be met by a Base Station transmitting on a single RF carrier configured in accordance with the manufacturer's specification. In addition, for a BS operating in non-contiguous spectrum, the requirements shall apply inside any sub-block gap. In addition, for a BS capable of multi-band operation, the requirements shall apply inside any inter-RF bandwidth gap.

For BS capable of multi-band operation where multiple bands are mapped on separate antenna connectors, the single-band requirements shall apply and the cumulative evaluation of the emission limit in the inter-RF bandwidth gap are not applicable.

Emissions shall not exceed the maximum level specified in tables 4.2.2.2-1 to 4.2.2.2-4A for the appropriate BS maximum output power, in the frequency range from $\Delta f = 2,5$ MHz to Δf_{\max} from the carrier frequency, where:

- Δf is the separation between the carrier frequency and the nominal -3 dB point of the measuring filter closest to the carrier frequency;
- f_{offset} is the separation between the carrier frequency and the centre of the measurement filter;
- $f_{\text{offset}_{\max}}$ is either 12,5 MHz or the offset to the UMTS Tx band edge as defined in clause 1, whichever is the greater;
- Δf_{\max} is equal to $f_{\text{offset}_{\max}}$ minus half of the bandwidth of the measuring filter.

Inside any inter-RF bandwidth gaps with $W_{\text{gap}} < 20$ MHz for BS operating in multiple bands, emissions shall not exceed the cumulative sum of the test requirements specified at the RF bandwidth edges on each side of the inter-RF bandwidth gap. The test requirement for RF bandwidth edge is specified in tables 4.2.2.2-1 to 4.2.2.2-6A below, where in this case:

- Δf is equal to 2,5 MHz plus the separation between the RF bandwidth edge frequency and the nominal -3 dB point of the measuring filter closest to the RF bandwidth edge.
- f_{offset} is equal to 2,5 MHz plus the separation between the RF bandwidth edge frequency and the centre of the measuring filter.
- $f_{\text{offset}_{\max}}$ is either 12,5 MHz or the offset to the UMTS Tx band edge as defined in clause 5.2, whichever is the greater.
- Δf_{\max} is equal to $f_{\text{offset}_{\max}}$ minus half of the bandwidth of the measuring filter.

Inside any sub-block gap for a BS operating in non-contiguous spectrum, the measurement results shall not exceed the cumulative sum of the test requirements specified for the adjacent sub-blocks on each side of the sub-block gap. The test requirement for each sub-block is specified in tables 4.2.2.2-1 to 4.2.2.2-6A below, where in this case:

- Δf is equal to 2,5 MHz plus the separation between the sub-block edge frequency and the nominal -3 dB point of the measuring filter closest to the sub-block edge.
- f_{offset} is equal to 2,5 MHz plus the separation between the sub-block edge frequency and the centre of the measuring filter.
- $f_{\text{offset}_{\max}}$ is equal to the sub-block gap bandwidth divided by two plus 2,5 MHz.
- Δf_{\max} is equal to $f_{\text{offset}_{\max}}$ minus half of the bandwidth of the measuring filter.

**Table 4.2.2-1: Spectrum emission mask values,
BS maximum output power $P \geq 43$ dBm for UTRA FDD bands ≤ 3 GHz**

Frequency offset of measurement filter -3 dB point, Δf	Frequency offset of measurement filter centre frequency, f_{offset}	Maximum level (Notes 1 and 2)	Measurement bandwidth (Note 4)
$2,5 \text{ MHz} \leq \Delta f < 2,7 \text{ MHz}$	$2,515 \text{ MHz} \leq f_{\text{offset}} < 2,715 \text{ MHz}$	-12,5 dBm	30 kHz
$2,7 \text{ MHz} \leq \Delta f < 3,5 \text{ MHz}$	$2,715 \text{ MHz} \leq f_{\text{offset}} < 3,515 \text{ MHz}$	$-12,5 \text{ dBm} - 15 \times \left(\frac{f_{\text{offset}}}{\text{MHz}} - 2,715 \right) \text{ dB}$	30 kHz
(Note 3)	$3,515 \text{ MHz} \leq f_{\text{offset}} < 4,0 \text{ MHz}$	-24,5 dBm	30 kHz
$3,5 \text{ MHz} \leq \Delta f \leq \Delta f_{\text{max}}$	$4,0 \text{ MHz} \leq f_{\text{offset}} < f_{\text{offset}_{\text{max}}}$	-11,5 dBm	1 MHz

NOTE 1: For BS supporting non-contiguous spectrum operation the test requirement within sub-block gaps within any operating band is calculated as a cumulative sum of contributions from adjacent sub-blocks on each side of the sub-block gap. Exception is $\Delta f \geq 12,5$ MHz from both adjacent sub-blocks on each side of the sub-block gap, where the spurious emission test requirements in clause 4.2.4.2.1 shall be met.

NOTE 2: For BS supporting multi-band operation with inter RF bandwidth gap < 20 MHz the minimum requirement within the inter RF bandwidth gaps is calculated as a cumulative sum of contributions from adjacent sub-blocks on each side of the inter RF bandwidth gap.

NOTE 3: This frequency range ensures that the range of values of f_{offset} is continuous.

NOTE 4: As a general rule, the resolution bandwidth of the measuring equipment should be equal to the measurement bandwidth. However, to improve measurement accuracy, sensitivity and efficiency, the resolution bandwidth can be smaller than the measurement bandwidth. When the resolution bandwidth is smaller than the measurement bandwidth, the result should be integrated over the measurement bandwidth in order to obtain the equivalent noise bandwidth of the measurement bandwidth.

**Table 4.2.2-1A: Spectrum emission mask values,
BS maximum output power $P \geq 43$ dBm for UTRA FDD bands > 3 GHz**

Frequency offset of measurement filter -3 dB point, Δf	Frequency offset of measurement filter centre frequency, f_{offset}	Maximum level (Notes 1 and 2)	Measurement bandwidth (Note 4)
$2,5 \text{ MHz} \leq \Delta f < 2,7 \text{ MHz}$	$2,515 \text{ MHz} \leq f_{\text{offset}} < 2,715 \text{ MHz}$	-12,2 dBm	30 kHz
$2,7 \text{ MHz} \leq \Delta f < 3,5 \text{ MHz}$	$2,715 \text{ MHz} \leq f_{\text{offset}} < 3,515 \text{ MHz}$	$-12,2 \text{ dBm} - 15 \times \left(\frac{f_{\text{offset}}}{\text{MHz}} - 2,715 \right) \text{ dB}$	30 kHz
(Note 3)	$3,515 \text{ MHz} \leq f_{\text{offset}} < 4,0 \text{ MHz}$	-24,2 dBm	30 kHz
$3,5 \text{ MHz} \leq \Delta f \leq \Delta f_{\text{max}}$	$4,0 \text{ MHz} \leq f_{\text{offset}} < f_{\text{offset}_{\text{max}}}$	-11,2 dBm	1 MHz

NOTE 1: For BS supporting non-contiguous spectrum operation the test requirement within sub-block gaps within any operating band is calculated as a cumulative sum of contributions from adjacent sub-blocks on each side of the sub-block gap. Exception is $\Delta f \geq 12,5$ MHz from both adjacent sub-blocks on each side of the sub-block gap, where the spurious emission test requirements in clause 4.2.4.2.1 shall be met.

NOTE 2: For BS supporting multi-band operation with inter-RF bandwidth gap < 20 MHz the minimum requirement with the inter-RF bandwidth gaps is calculated as a cumulative sum of contributions from adjacent sub-blocks on each side of the inter-R bandwidth gap.

NOTE 3: This frequency range ensures that the range of values of f_{offset} is continuous.

NOTE 4: As a general rule, the resolution bandwidth of the measuring equipment should be equal to the measurement bandwidth. However, to improve measurement accuracy, sensitivity and efficiency, the resolution bandwidth can be smaller than the measurement bandwidth. When the resolution bandwidth is smaller than the measurement bandwidth, the result should be integrated over the measurement bandwidth in order to obtain the equivalent noise bandwidth of the measurement bandwidth.

**Table 4.2.2-2: Spectrum emission mask values,
BS maximum output power $39 \text{ dBm} \leq P < 43 \text{ dBm}$ for UTRA FDD bands $\leq 3 \text{ GHz}$**

Frequency offset of measurement filter -3 dB point, Δf	Frequency offset of measurement filter centre frequency, f_{offset}	Maximum level (Notes 1 and 2)	Measurement bandwidth (Note 4)
$2,5 \text{ MHz} \leq \Delta f < 2,7 \text{ MHz}$	$2,515 \text{ MHz} \leq f_{\text{offset}} < 2,715 \text{ MHz}$	-12,5 dBm	30 kHz
$2,7 \text{ MHz} \leq \Delta f < 3,5 \text{ MHz}$	$2,715 \text{ MHz} \leq f_{\text{offset}} < 3,515 \text{ MHz}$	$-12,5 \text{ dBm} - 15 \times \left(\frac{f_{\text{offset}}}{\text{MHz}} - 2,715 \right) \text{ dB}$	30 kHz
(Note 3)	$3,515 \text{ MHz} \leq f_{\text{offset}} < 4,0 \text{ MHz}$	-24,5 dBm	30 kHz
$3,5 \text{ MHz} \leq \Delta f < 7,5 \text{ MHz}$	$4,0 \text{ MHz} \leq f_{\text{offset}} < 8,0 \text{ MHz}$	-11,5 dBm	1 MHz
$7,5 \text{ MHz} \leq \Delta f \leq \Delta f_{\text{max}}$	$8,0 \text{ MHz} \leq f_{\text{offset}} < f_{\text{offset}_{\text{max}}}$	$P - 54,5 \text{ dB}$	1 MHz
<p>NOTE 1: For BS supporting non-contiguous spectrum operation the test requirement within sub-block gaps within any operating band is calculated as a cumulative sum of contributions from adjacent sub-blocks on each side of the sub-block gap. Exception is $\Delta f \geq 12,5 \text{ MHz}$ from both adjacent sub-blocks on each side of the sub-block gap, where the spurious emission test requirements in clause 4.2.4.2.1 shall be met.</p> <p>NOTE 2: For BS supporting multi-band operation with inter-RF bandwidth gap $< 20 \text{ MHz}$ the minimum requirement with the inter-RF bandwidth gaps is calculated as a cumulative sum of contributions from adjacent sub-blocks on each side of the inter-R bandwidth gap.</p> <p>NOTE 3: This frequency range ensures that the range of values of f_{offset} is continuous.</p> <p>NOTE 4: As a general rule, the resolution bandwidth of the measuring equipment should be equal to the measurement bandwidth. However, to improve measurement accuracy, sensitivity and efficiency, the resolution bandwidth can be smaller than the measurement bandwidth. When the resolution bandwidth is smaller than the measurement bandwidth, the result should be integrated over the measurement bandwidth in order to obtain the equivalent noise bandwidth of the measurement bandwidth.</p>			

**Table 4.2.2-2A: Spectrum emission mask values,
BS maximum output power $39 \text{ dBm} \leq P < 43 \text{ dBm}$ for UTRA FDD bands $> 3 \text{ GHz}$**

Frequency offset of measurement filter -3 dB point, Δf	Frequency offset of measurement filter centre frequency, f_{offset}	Maximum level (Notes 1 and 2)	Measurement bandwidth (Note 4)
$2,5 \text{ MHz} \leq \Delta f < 2,7 \text{ MHz}$	$2,515 \text{ MHz} \leq f_{\text{offset}} < 2,715 \text{ MHz}$	-12,2 dBm	30 kHz
$2,7 \text{ MHz} \leq \Delta f < 3,5 \text{ MHz}$	$2,715 \text{ MHz} \leq f_{\text{offset}} < 3,515 \text{ MHz}$	$-12,2 \text{ dBm} - 15 \times \left(\frac{f_{\text{offset}}}{\text{MHz}} - 2,715 \right) \text{ dB}$	30 kHz
(Note 3)	$3,515 \text{ MHz} \leq f_{\text{offset}} < 4,0 \text{ MHz}$	-24,2 dBm	30 kHz
$3,5 \text{ MHz} \leq \Delta f < 7,5 \text{ MHz}$	$4,0 \text{ MHz} \leq f_{\text{offset}} < 8,0 \text{ MHz}$	-11,2 dBm	1 MHz
$7,5 \text{ MHz} \leq \Delta f \leq \Delta f_{\text{max}}$	$8,0 \text{ MHz} \leq f_{\text{offset}} < f_{\text{offset}_{\text{max}}}$	$P - 54,2 \text{ dB}$	1 MHz
<p>NOTE 1: For BS supporting non-contiguous spectrum operation the test requirement within sub-block gaps within any operating band is calculated as a cumulative sum of contributions from adjacent sub-blocks on each side of the sub-block gap. Exception is $\Delta f \geq 12,5 \text{ MHz}$ from both adjacent sub-blocks on each side of the sub-block gap, where the spurious emission test requirements in clause 4.2.4.2.1 shall be met.</p> <p>NOTE 2: For BS supporting multi-band operation with inter-RF bandwidth gap $< 20 \text{ MHz}$ the minimum requirement with the inter-RF bandwidth gaps is calculated as a cumulative sum of contributions from adjacent sub-blocks on each side of the inter-R bandwidth gap.</p> <p>NOTE 3: This frequency range ensures that the range of values of f_{offset} is continuous.</p> <p>NOTE 4: As a general rule, the resolution bandwidth of the measuring equipment should be equal to the measurement bandwidth. However, to improve measurement accuracy, sensitivity and efficiency, the resolution bandwidth can be smaller than the measurement bandwidth. When the resolution bandwidth is smaller than the measurement bandwidth, the result should be integrated over the measurement bandwidth in order to obtain the equivalent noise bandwidth of the measurement bandwidth.</p>			

**Table 4.2.2-3: Spectrum emission mask values,
BS maximum output power $31 \text{ dBm} \leq P < 39 \text{ dBm}$ for UTRA FDD bands $\leq 3 \text{ GHz}$**

Frequency offset of measurement filter -3 dB point, Δf	Frequency offset of measurement filter centre frequency, f_{offset}	Maximum level (Notes 1 and 2)	Measurement bandwidth (Note 4)
$2,5 \text{ MHz} \leq \Delta f < 2,7 \text{ MHz}$	$2,515 \text{ MHz} \leq f_{\text{offset}} < 2,715 \text{ MHz}$	$P - 51,5 \text{ dB}$	30 kHz
$2,7 \text{ MHz} \leq \Delta f < 3,5 \text{ MHz}$	$2,715 \text{ MHz} \leq f_{\text{offset}} < 3,515 \text{ MHz}$	$P - 51,5 \text{ dB} - 15 \times \left(\frac{f_{\text{offset}}}{\text{MHz}} - 2,715 \right) \text{ dB}$	30 kHz
(Note 3)	$3,515 \text{ MHz} \leq f_{\text{offset}} < 4,0 \text{ MHz}$	$P - 63,5 \text{ dB}$	30 kHz
$3,5 \text{ MHz} \leq \Delta f < 7,5 \text{ MHz}$	$4,0 \text{ MHz} \leq f_{\text{offset}} < 8,0 \text{ MHz}$	$P - 50,5 \text{ dB}$	1 MHz
$7,5 \text{ MHz} \leq \Delta f \leq \Delta f_{\text{max}}$	$8,0 \text{ MHz} \leq f_{\text{offset}} < f_{\text{offset}_{\text{max}}}$	$P - 54,5 \text{ dB}$	1 MHz
<p>NOTE 1: For BS supporting non-contiguous spectrum operation the test requirement within sub-block gaps within any operating band is calculated as a cumulative sum of contributions from adjacent sub-blocks on each side of the sub-block gap. Exception is $\Delta f \geq 12,5 \text{ MHz}$ from both adjacent sub-blocks on each side of the sub-block gap, where the spurious emission test requirements in clause 4.2.4.2.1 shall be met.</p> <p>NOTE 2: For BS supporting multi-band operation with inter-RF bandwidth gap $< 20 \text{ MHz}$ the minimum requirement with the inter-RF bandwidth gaps is calculated as a cumulative sum of contributions from adjacent sub-blocks on each side of the inter-R bandwidth gap.</p> <p>NOTE 3: This frequency range ensures that the range of values of f_{offset} is continuous.</p> <p>NOTE 4: As a general rule, the resolution bandwidth of the measuring equipment should be equal to the measurement bandwidth. However, to improve measurement accuracy, sensitivity and efficiency, the resolution bandwidth can be smaller than the measurement bandwidth. When the resolution bandwidth is smaller than the measurement bandwidth, the result should be integrated over the measurement bandwidth in order to obtain the equivalent noise bandwidth of the measurement bandwidth.</p>			

**Table 4.2.2-3A: Spectrum emission mask values,
BS maximum output power $31 \text{ dBm} \leq P < 39 \text{ dBm}$ for UTRA FDD bands $> 3 \text{ GHz}$**

Frequency offset of measurement filter -3 dB point, Δf	Frequency offset of measurement filter centre frequency, f_{offset}	Maximum level (Notes 1 and 2)	Measurement bandwidth (Note 4)
$2,5 \text{ MHz} \leq \Delta f < 2,7 \text{ MHz}$	$2,515 \text{ MHz} \leq f_{\text{offset}} < 2,715 \text{ MHz}$	$P - 51,2 \text{ dB}$	30 kHz
$2,7 \text{ MHz} \leq \Delta f < 3,5 \text{ MHz}$	$2,715 \text{ MHz} \leq f_{\text{offset}} < 3,515 \text{ MHz}$	$P - 51,5 \text{ dB} - 15 \times \left(\frac{f_{\text{offset}}}{\text{MHz}} - 2,715 \right) \text{ dB}$	30 kHz
(Note 3)	$3,515 \text{ MHz} \leq f_{\text{offset}} < 4,0 \text{ MHz}$	$P - 63,2 \text{ dB}$	30 kHz
$3,5 \text{ MHz} \leq \Delta f < 7,5 \text{ MHz}$	$4,0 \text{ MHz} \leq f_{\text{offset}} < 8,0 \text{ MHz}$	$P - 50,2 \text{ dB}$	1 MHz
$7,5 \text{ MHz} \leq \Delta f \leq \Delta f_{\text{max}}$	$8,0 \text{ MHz} \leq f_{\text{offset}} < f_{\text{offset}_{\text{max}}}$	$P - 54,2 \text{ dB}$	1 MHz
<p>NOTE 1: For BS supporting non-contiguous spectrum operation the test requirement within sub-block gaps within any operating band is calculated as a cumulative sum of contributions from adjacent sub-blocks on each side of the sub-block gap. Exception is $\Delta f \geq 12,5 \text{ MHz}$ from both adjacent sub-blocks on each side of the sub-block gap, where the spurious emission test requirements in clause 4.2.4.2.1 shall be met.</p> <p>NOTE 2: For BS supporting multi-band operation with inter-RF bandwidth gap $< 20 \text{ MHz}$ the minimum requirement with the inter-RF bandwidth gaps is calculated as a cumulative sum of contributions from adjacent sub-blocks on each side of the inter-R bandwidth gap.</p> <p>NOTE 3: This frequency range ensures that the range of values of f_{offset} is continuous.</p> <p>NOTE 4: As a general rule, the resolution bandwidth of the measuring equipment should be equal to the measurement bandwidth. However, to improve measurement accuracy, sensitivity and efficiency, the resolution bandwidth can be smaller than the measurement bandwidth. When the resolution bandwidth is smaller than the measurement bandwidth, the result should be integrated over the measurement bandwidth in order to obtain the equivalent noise bandwidth of the measurement bandwidth.</p>			

**Table 4.2.2-4: Spectrum emission mask values,
BS maximum output power P < 31 dBm for UTRA FDD bands ≤ 3 GHz**

Frequency offset of measurement filter -3 dB point, Δf	Frequency offset of measurement filter centre frequency, f_{offset}	Maximum level (Notes 1 and 2)	Measurement bandwidth (Note 4)
$2,5 \text{ MHz} \leq \Delta f < 2,7 \text{ MHz}$	$2,515 \text{ MHz} \leq f_{\text{offset}} < 2,715 \text{ MHz}$	-20,5 dBm	30 kHz
$2,7 \text{ MHz} \leq \Delta f < 3,5 \text{ MHz}$	$2,715 \text{ MHz} \leq f_{\text{offset}} < 3,515 \text{ MHz}$	$-20,5 \text{ dBm} - 15 \times \left(\frac{f_{\text{offset}}}{\text{MHz}} - 2,715 \right) \text{ dB}$	30 kHz
(Note 3)	$3,515 \text{ MHz} \leq f_{\text{offset}} < 4,0 \text{ MHz}$	-32,5 dBm	30 kHz
$3,5 \text{ MHz} \leq \Delta f < 7,5 \text{ MHz}$	$4,0 \text{ MHz} \leq f_{\text{offset}} < 8,0 \text{ MHz}$	-19,5 dBm	1 MHz
$7,5 \text{ MHz} \leq \Delta f \leq \Delta f_{\text{max}}$	$8,0 \text{ MHz} \leq f_{\text{offset}} < f_{\text{offset}_{\text{max}}}$	-23,5 dBm	1 MHz
<p>NOTE 1: For BS supporting non-contiguous spectrum operation the test requirement within sub-block gaps within any operating band is calculated as a cumulative sum of contributions from adjacent sub-blocks on each side of the sub-block gap. Exception is $\Delta f \geq 12,5 \text{ MHz}$ from both adjacent sub-blocks on each side of the sub-block gap, where the spurious emission test requirements in clause 4.2.4.2.1 shall be met.</p> <p>NOTE 2: For BS supporting multi-band operation with inter-RF bandwidth gap < 20 MHz the minimum requirement with the inter-RF bandwidth gaps is calculated as a cumulative sum of contributions from adjacent sub-blocks on each side of the inter-R bandwidth gap.</p> <p>NOTE 3: This frequency range ensures that the range of values of f_{offset} is continuous.</p> <p>NOTE 4: As a general rule, the resolution bandwidth of the measuring equipment should be equal to the measurement bandwidth. However, to improve measurement accuracy, sensitivity and efficiency, the resolution bandwidth can be smaller than the measurement bandwidth. When the resolution bandwidth is smaller than the measurement bandwidth, the result should be integrated over the measurement bandwidth in order to obtain the equivalent noise bandwidth of the measurement bandwidth.</p>			

**Table 4.2.2-4A: Spectrum emission mask values,
BS maximum output power P < 31 dBm for UTRA FDD bands > 3 GHz**

Frequency offset of measurement filter -3 dB point, Δf	Frequency offset of measurement filter centre frequency, f_{offset}	Maximum level (Notes 1 and 2)	Measurement bandwidth (Note 4)
$2,5 \text{ MHz} \leq \Delta f < 2,7 \text{ MHz}$	$2,515 \text{ MHz} \leq f_{\text{offset}} < 2,715 \text{ MHz}$	-20,2 dBm	30 kHz
$2,7 \text{ MHz} \leq \Delta f < 3,5 \text{ MHz}$	$2,715 \text{ MHz} \leq f_{\text{offset}} < 3,515 \text{ MHz}$	$-20,2 \text{ dBm} - 15 \times \left(\frac{f_{\text{offset}}}{\text{MHz}} - 2,715 \right) \text{ dB}$	30 kHz
(Note 3)	$3,515 \text{ MHz} \leq f_{\text{offset}} < 4,0 \text{ MHz}$	-32,2 dBm	30 kHz
$3,5 \text{ MHz} \leq \Delta f < 7,5 \text{ MHz}$	$4,0 \text{ MHz} \leq f_{\text{offset}} < 8,0 \text{ MHz}$	-19,2 dBm	1 MHz
$7,5 \text{ MHz} \leq \Delta f \leq \Delta f_{\text{max}}$	$8,0 \text{ MHz} \leq f_{\text{offset}} < f_{\text{offset}_{\text{max}}}$	-23,2 dBm	1 MHz
<p>NOTE 1: For BS supporting non-contiguous spectrum operation the test requirement within sub-block gaps within any operating band is calculated as a cumulative sum of contributions from adjacent sub-blocks on each side of the sub-block gap. Exception is $\Delta f \geq 12,5 \text{ MHz}$ from both adjacent sub-blocks on each side of the sub-block gap, where the spurious emission test requirements in clause 4.2.4.2.1 shall be met.</p> <p>NOTE 2: For BS supporting multi-band operation with inter-RF bandwidth gap < 20 MHz the minimum requirement with the inter-RF bandwidth gaps is calculated as a cumulative sum of contributions from adjacent sub-blocks on each side of the inter-R bandwidth gap.</p> <p>NOTE 3: This frequency range ensures that the range of values of f_{offset} is continuous.</p> <p>NOTE 4: As a general rule, the resolution bandwidth of the measuring equipment should be equal to the measurement bandwidth. However, to improve measurement accuracy, sensitivity and efficiency, the resolution bandwidth can be smaller than the measurement bandwidth. When the resolution bandwidth is smaller than the measurement bandwidth, the result should be integrated over the measurement bandwidth in order to obtain the equivalent noise bandwidth of the measurement bandwidth.</p>			

For Home BS, the requirements in tables 4.2.2.2-5 or 4.2.2.2-6 shall apply in addition to the requirements in tables 4.2.2.2-1 to 4.2.2.2-4.

Table 4.2.2.2-5: Additional spectrum emission mask values for Home BS, BS maximum output power $6 \leq P \leq 20$ dBm for UTRA FDD bands ≤ 3 GHz

Frequency offset of measurement filter - 3 dB point, Δf	Frequency offset of measurement filter centre frequency, f_{offset}	Maximum level (additional)	Measurement bandwidth (Note)
$12,5 \text{ MHz} \leq \Delta f \leq \Delta f_{\text{max}}$	$13 \text{ MHz} \leq f_{\text{offset}} < f_{\text{offset}_{\text{max}}}$	P - 54,5 dB	1 MHz
NOTE: As a general rule, the resolution bandwidth of the measuring equipment should be equal to the measurement bandwidth. However, to improve measurement accuracy, sensitivity and efficiency, the resolution bandwidth can be smaller than the measurement bandwidth. When the resolution bandwidth is smaller than the measurement bandwidth, the result should be integrated over the measurement bandwidth in order to obtain the equivalent noise bandwidth of the measurement bandwidth.			

Table 4.2.2.2-5A: Additional spectrum emission mask values for Home BS, BS maximum output power $6 \leq P \leq 20$ dBm for UTRA FDD bands > 3 GHz

Frequency offset of measurement filter - 3 dB point, Δf	Frequency offset of measurement filter centre frequency, f_{offset}	Maximum level (additional)	Measurement bandwidth (Note)
$12,5 \text{ MHz} \leq \Delta f \leq \Delta f_{\text{max}}$	$13 \text{ MHz} \leq f_{\text{offset}} < f_{\text{offset}_{\text{max}}}$	P - 54,2 dB	1 MHz
NOTE: As a general rule, the resolution bandwidth of the measuring equipment should be equal to the measurement bandwidth. However, to improve measurement accuracy, sensitivity and efficiency, the resolution bandwidth can be smaller than the measurement bandwidth. When the resolution bandwidth is smaller than the measurement bandwidth, the result should be integrated over the measurement bandwidth in order to obtain the equivalent noise bandwidth of the measurement bandwidth.			

Table 4.2.2.2-6: Additional spectrum emission mask values for Home BS, BS maximum output power $P < 6$ dBm for UTRA FDD bands ≤ 3 GHz

Frequency offset of measurement filter - 3 dB point, Δf	Frequency offset of measurement filter centre frequency, f_{offset}	Maximum level (additional)	Measurement bandwidth (Note)
$12,5 \text{ MHz} \leq \Delta f \leq \Delta f_{\text{max}}$	$13 \text{ MHz} \leq f_{\text{offset}} < f_{\text{offset}_{\text{max}}}$	-48,5 dBm	1 MHz
NOTE: As a general rule, the resolution bandwidth of the measuring equipment should be equal to the measurement bandwidth. However, to improve measurement accuracy, sensitivity and efficiency, the resolution bandwidth can be smaller than the measurement bandwidth. When the resolution bandwidth is smaller than the measurement bandwidth, the result should be integrated over the measurement bandwidth in order to obtain the equivalent noise bandwidth of the measurement bandwidth.			

Table 4.2.2.2-6A: Additional spectrum emission mask values for Home BS, BS maximum output power $P < 6$ dBm for UTRA FDD bands > 3 GHz

Frequency offset of measurement filter - 3 dB point, Δf	Frequency offset of measurement filter centre frequency, f_{offset}	Maximum level (additional)	Measurement bandwidth (Note)
$12,5 \text{ MHz} \leq \Delta f \leq \Delta f_{\text{max}}$	$13 \text{ MHz} \leq f_{\text{offset}} < f_{\text{offset}_{\text{max}}}$	-48,2 dBm	1 MHz
NOTE: As a general rule, the resolution bandwidth of the measuring equipment should be equal to the measurement bandwidth. However, to improve measurement accuracy, sensitivity and efficiency, the resolution bandwidth can be smaller than the measurement bandwidth. When the resolution bandwidth is smaller than the measurement bandwidth, the result should be integrated over the measurement bandwidth in order to obtain the equivalent noise bandwidth of the measurement bandwidth.			

The following requirement shall apply for protection of DTT. For UTRA BS operating in Band XX, the level of emissions in the band 470 MHz to 790 MHz, measured in an 8 MHz filter bandwidth on centre frequencies F_{filter} according to table 4.2.2.2-7, shall not exceed the maximum emission level $P_{\text{EM,N}}$ declared by the manufacturer.

Table 4.2.2.2-7: Declared emissions levels for protection of DTT

Filter centre frequency, F_{filter}	Measurement bandwidth	Declared emission level [dBm]
$F_{\text{filter}} = 8 \cdot N + 306$ (MHz); $21 \leq N \leq 60$	8 MHz	$P_{\text{EM},N}$

NOTE 1: Compliance with the declared emission levels above provides the characteristics of the base station needed to verify compliance with the corresponding CEPT/ECC technical condition using the method outlined in annex D of ETSI TS 125 104 [9].

In certain regions, the following requirements may apply to UTRA BS operating in Band XXXII within 1 452 - 1 492 MHz. The level of unwanted emissions, measured on centre frequencies f_{offset} with filter bandwidth, according to table 4.2.2.2-8, shall neither exceed the maximum emission level $P_{\text{EM},B32,a}$, $P_{\text{EM},B32,b}$ nor $P_{\text{EM},B32,c}$ declared by the manufacturer.

Table 4.2.2.2-8: Declared frequency band XXXII unwanted emission within 1 452 - 1 492 MHz

Frequency offset of measurement filter centre frequency, f_{offset}	Declared emission level [dBm]	Measurement bandwidth
5 MHz	$P_{\text{EM},B32,a}$	5 MHz
10 MHz	$P_{\text{EM},B32,b}$	5 MHz
$15 \text{ MHz} \leq f_{\text{offset}} \leq f_{\text{offset,max},B32}$	$P_{\text{EM},B32,c}$	5 MHz
NOTE: $f_{\text{offset,max},B32}$ denotes the frequency difference between the lower channel carrier frequency and 1 454,5 MHz, and the frequency difference between the upper channel carrier frequency and 1 489,5 MHz for the set channel position.		

NOTE 2: The regional requirement, included in [i.9], is defined in terms of EIRP per antenna, which is dependent on both the BS emissions at the antenna connector and the deployment (including antenna gain and feeder loss). The requirement defined above provides the characteristics of the base station needed to verify compliance with the regional requirement. The assessment of the EIRP level is described in annex H of ETSI TS 136 104 [5].

In certain regions, the following requirement may apply to UTRA BS operating in Band XXXII within 1 452 - 1 492 MHz for the protection of services in spectrum adjacent to the frequency range 1 452 - 1 492 MHz. The level of emissions, measured on centre frequencies F_{filter} with filter bandwidth according to table 4.2.2.2-9, shall neither exceed the maximum emission level $P_{\text{EM},B32,d}$ nor $P_{\text{EM},B32,e}$ declared by the manufacturer. This requirement applies in the frequency range 1 452 - 1 492 MHz even though part of the range falls in the spurious domain.

Table 4.2.2.2-9: Frequency band XXXII declared emission outside 1 452 - 1 492 MHz

Filter centre frequency, F_{filter}	Declared emission level [dBm]	Measurement bandwidth
$1\,429,5 \text{ MHz} \leq F_{\text{filter}} \leq 1\,448,5 \text{ MHz}$	$P_{\text{EM},B32,d}$	1 MHz
$F_{\text{filter}} = 1\,450,5 \text{ MHz}$	$P_{\text{EM},B32,e}$	3 MHz
$F_{\text{filter}} = 1\,493,5 \text{ MHz}$	$P_{\text{EM},B32,e}$	3 MHz
$1\,495,5 \text{ MHz} \leq F_{\text{filter}} \leq 1\,517,5 \text{ MHz}$	$P_{\text{EM},B32,d}$	1 MHz

NOTE 2a: The regional requirement, included in [i.9], is defined in terms of EIRP, which is dependent on both the BS emissions at the antenna connector and the deployment (including antenna gain and feeder loss). The requirement defined above provides the characteristics of the base station needed to verify compliance with the regional requirement. The assessment of the EIRP level is described in annex H of ETSI TS 136 104 [5].

4.2.2.3 Conformance

Conformance tests described in clause 5.3.1 shall be carried out.

4.2.3 Adjacent channel leakage power ratio (ACLR)

4.2.3.1 Definition

Adjacent Channel Leakage power Ratio (ACLR) is the ratio of the RRC filtered mean power centred on the assigned channel frequency to the RRC filtered mean power centred on an adjacent channel frequency.

The requirements shall apply outside the BS RF bandwidth edges or maximum radio bandwidth edges whatever the type of transmitter considered (single carrier or multi-carrier). It shall apply for all transmission modes foreseen by the manufacturer's specification.

For a BS operating in non-contiguous spectrum, ACLR requirement also shall apply for the first adjacent channel, inside any sub-block gap with a gap size $W_{\text{gap}} \geq 15$ MHz. The ACLR requirement for the second adjacent channel shall apply inside any sub-block gap with a gap size $W_{\text{gap}} \geq 20$ MHz. The ACLR requirement in clause 6.5.2.2.2 shall apply in sub-block gaps for the frequency ranges defined in table 4.2.3.2-2.

For a BS operating in multiple bands, where multiple bands are mapped onto the same antenna connector, ACLR requirement also shall apply for the first adjacent channel, inside any inter RF bandwidth gap with a gap size $W_{\text{gap}} \geq 15$ MHz. The ACLR requirement for the second adjacent channel shall apply inside any inter RF bandwidth gap with a gap size $W_{\text{gap}} \geq 20$ MHz. The ACLR requirement in clause 6.5.2.2.2 shall apply in inter RF bandwidth gaps for the frequency ranges defined in table 4.2.3.2-2.

4.2.3.2 Limits

For Category A Wide Area BS, either the ACLR limits in the tables below or the absolute limit of -13 dBm/MHz shall apply, whichever is less stringent.

For Category B Wide Area BS, either the ACLR limits in the tables below or the absolute limit of -15 dBm/MHz shall apply, whichever is less stringent.

For Medium Range BS, either the ACLR limits in the tables below or the absolute limit of -25 dBm/MHz shall apply, whichever is less stringent.

For Local Area BS, either the ACLR limits in the tables below or the absolute limit of -32 dBm/MHz shall apply, whichever is less stringent.

The measurement result in step 1 of 5.3.2.2 shall not be less than the ACLR limit specified in table 4.2.3.2-1.

Table 4.2.3.2-1: BS ACLR limits

BS channel offset below the first or above the last carrier frequency transmitted	ACLR limit
5 MHz	44,2 dB
10 MHz	49,2 dB
NOTE: For Home BS, the adjacent channel power (the RRC filtered mean power centred on an adjacent channel frequency) shall be less than or equal to -42,7 dBm/3,84 MHz for $f \leq 3,0$ GHz and -42,4 dBm/3,84 MHz for $3,0 \text{ GHz} < f \leq 4,2 \text{ GHz}$ or as specified by the ACLR limit, whichever is the higher.	

The measurement result in step 2a of 5.3.2.2 shall not be less than the ACLR limit specified in table 4.2.3.2-2.

Table 4.2.3.2-2: BS ACLR in non-contiguous spectrum or multiple bands

Sub-block or inter RF bandwidth gap size (W_{gap}) where the limit applies	BS adjacent channel centre frequency offset below or above the sub-block edge or the RF bandwidth edge (inside the gap)	Assumed adjacent channel carrier (informative)	Filter on the adjacent channel frequency and corresponding filter bandwidth	ACLR limit
$W_{\text{gap}} \geq 15$ MHz	2,5 MHz	3,84 Mcps UTRA	RRC (3,84 Mcps)	44,2 dB
$W_{\text{gap}} \geq 20$ MHz	7,5 MHz	3,84 Mcps UTRA	RRC (3,84 Mcps)	44,2 dB
NOTE: The RRC filter shall be equivalent to the transmit pulse shape filter defined in ETSI TS 125 104 [9], with a chip rate as defined in this table.				

4.2.3.3 Cumulative ACLR test requirement in non-contiguous spectrum or multiple-bands

The following test requirement shall apply for a BS operating in non-contiguous spectrum or multiple bands.

The following requirement shall apply for the gap sizes listed in table 4.2.3.3-1:

- inside a sub-block gap within an operating band for a BS operating in non-contiguous spectrum;
- inside an inter-RF bandwidth gap for a BS capable of multi-band operation, where multiple bands are mapped on the same antenna connector.

The Cumulative Adjacent Channel Leakage power Ratio (CACLR) in a sub-block gap or inter-RF bandwidth gap is the ratio of:

- a) the sum of the filtered mean power centred on the assigned channel frequencies for the two carriers adjacent to each side of the sub-block gap or inter-RF bandwidth gap; and
- b) the filtered mean power centred on a frequency channel adjacent to one of the respective sub-block edges or RF bandwidth edges.

The assumed filter for the adjacent channel frequency is defined in table 4.2.3.3-1 and the filters on the assigned channels are defined in table 4.2.3.3-2.

For Wide Area Category A BS, either the CACLR limits in table 4.2.3.3-1 or the absolute limit of -13 dBm/MHz shall apply, whichever is less stringent.

For Wide Area Category B BS, either the CACLR limits in table 4.2.3.3-1 or the absolute limit of -15 dBm/MHz shall apply, whichever is less stringent.

For Medium Range BS, either the CACLR limits in table 4.2.3.3-1 or the absolute limit of -25 dBm/MHz shall apply, whichever is less stringent.

For Local Area BS, either the CACLR limits in table 4.2.3.3-1 or the absolute limit of -32 dBm/MHz shall apply, whichever is less stringent.

The CACLR for UTRA carriers located on either side of the sub-block gap or inter-RF bandwidth gap shall be higher than the value specified in table 4.2.3.3-1.

Table 4.2.3.3-1: Base Station CACLR in non-contiguous spectrum or multiple bands

Sub-block or inter-RF bandwidth gap size (W_{gap}) where the limit applies	BS adjacent channel centre frequency offset below or above the sub-block edge or the RF bandwidth edge (inside the gap)	Assumed adjacent channel carrier (informative)	Filter on the adjacent channel frequency and corresponding filter bandwidth	CACLR limit
$5 \text{ MHz} \leq W_{\text{gap}} < 15 \text{ MHz}$	2,5 MHz	3,84 Mcps UTRA	RRC (3,84 Mcps)	44,2 dB
$10 \text{ MHz} < W_{\text{gap}} < 20 \text{ MHz}$	7,5 MHz	3,84 Mcps UTRA	RRC (3,84 Mcps)	44,2 dB
NOTE: The RRC filter shall be equivalent to the transmit pulse shape filter defined in ETSI TS 125 104 [9], with a chip rate as defined in this table.				

Table 4.2.3.3-2: Filter parameters for the assigned channel

RAT of the carrier adjacent to the sub-block or inter-RF bandwidth gap	Filter on the assigned channel frequency and corresponding filter bandwidth
UTRA FDD	RRC (3,84 Mcps)
NOTE: The RRC filter shall be equivalent to the transmit pulse shape filter defined in ETSI TS 125 104 [9], with a chip rate as defined in this table.	

4.2.3.4 Conformance

Conformance tests described in clause 5.3.2 shall be carried out.

4.2.4 Transmitter spurious emissions

4.2.4.1 Definition

Spurious emissions are emissions which are caused by unwanted transmitter effects such as harmonics emission, parasitic emission, intermodulation products and frequency conversion products, but exclude out-of-band emissions. This is measured at the BS antenna connector.

For a UTRA FDD BS additionally conforming to ETSI EN 301 908-18 [i.8], either the requirement of the present clause or the Transmitter spurious emissions requirement in clause 4.2.4 of ETSI EN 301 908-18 [i.8] can be equally applied, as listed in table 4.2.1-2.

The requirement shall apply at frequencies within the specified frequency ranges, which are more than 12,5 MHz under the first carrier frequency transmitted or more than 12,5 MHz above the last carrier frequency transmitted.

The requirements of clause 4.2.4.2 shall apply whatever the type of transmitter considered (single carrier or multi-carrier). It shall apply for all transmission modes foreseen by the manufacturer's specification.

For BS capable of multi-band operation where multiple bands are mapped on the same antenna connector, the requirements (except exceptions in table 4.2.4.2.2-1) shall apply at frequencies within the specified frequency ranges, excluding the frequency ranges which are less than or equal to 12,5 MHz below the first carrier frequency used and less than or equal to 12,5 MHz above the last carrier frequency used for each supported operating band. For BS capable of multi-band operation where multiple bands are mapped on separate antenna connectors, the single-band requirements shall apply and the multi-band exclusions and provisions are not applicable.

Unless otherwise stated, all requirements shall be measured as mean power.

4.2.4.2 Limits

4.2.4.2.1 Spurious emissions

The power of any spurious emission shall not exceed the limit specified in tables 4.2.4.2.1-1 or 4.2.4.2.1-2 depending on the declared operating band.

Table 4.2.4.2.1-1: BS spurious emissions limits for operating band I, III, VII, XV, XVI, and XXXII

Frequency range	Maximum level	Measurement bandwidth	Note
9 kHz to 150 kHz	-36 dBm	1 kHz	see note 1
150 kHz to 30 MHz	-36 dBm	10 kHz	see note 1
30 MHz to 1 GHz	-36 dBm	100 kHz	see note 1
1 GHz to $F_{low} - 10$ MHz	-30 dBm	1 MHz	see note 1
$F_{low} - 10$ MHz to $F_{high} + 10$ MHz	-15 dBm	1 MHz	see note 2
$F_{high} + 10$ MHz to 12,75 GHz	-30 dBm	1 MHz	see note 3
12,75 GHz to 5 th harmonic of the upper frequency edge of the DL operating band	-30 dBm	1 MHz	see notes 3 and 4
NOTE 1: Bandwidth as in Recommendation ITU-R SM.329-12 [3], section 4.1.			
NOTE 2: Limit based on Recommendation ITU-R SM.329-12 [3], section 4.3 and annex 7.			
NOTE 3: Bandwidth as in Recommendation ITU-R SM.329-12 [3], section 4.1. Upper frequency as in Recommendation ITU-R SM.329-12 [3], section 2.5, table 1.			
NOTE 4: Applies only for Band XXII.			
Key:			
F_{low} :	The lowest BS transmit frequency of the operating band as defined in table 1-1.		
F_{high} :	The highest BS transmit frequency of the operating band as defined in table 1-1.		

Table 4.2.4.2.1-2: BS spurious emissions limits for operating band VIII and XX

Frequency range	Maximum level	Measurement bandwidth	Note
9 kHz to 150 kHz	-36 dBm	1 kHz	see note 1
150 kHz to 30 MHz	-36 dBm	10 kHz	see note 1
30 MHz to $F_{low} - 10$ MHz	-36 dBm	100 kHz	see note 1
$F_{low} - 10$ MHz to $F_{high} + 10$ MHz	-16 dBm	100 kHz	see note 2
$F_{high} + 10$ MHz to 1 GHz	-36 dBm	100 kHz	see note 1
1 GHz to 12,75 GHz	-30 dBm	1 MHz	see note 3
NOTE 1: Bandwidth as in Recommendation ITU-R SM.329-12 [3], section 4.1.			
NOTE 2: Limit based on Recommendation ITU-R SM.329-12 [3], section 4.3 and annex 7.			
NOTE 3: Bandwidth as in Recommendation ITU-R SM.329-12 [3], section 4.1. Upper frequency as in Recommendation ITU-R SM.329-12 [3], section 2.5, table 1.			
Key:			
F_{low} : The lowest BS transmit frequency of the operating band as defined in table 1-1.			
F_{high} : The highest BS transmit frequency of the operating band as defined in table 1-1.			

4.2.4.2.2 Co-existence with other systems

This requirement shall be applied for the protection of UE/MS and BS/BTS receivers of other systems.

The power of any spurious emission shall not exceed the limit specified in table 4.2.4.2.2-1.

Table 4.2.4.2.2-1: Spurious emissions limits for protection of other systems

Protected system	Frequency range for co-existence requirement	Maximum Level	Measurement Bandwidth	Note
GSM900	921 MHz to 960 MHz	-57 dBm	100 kHz	This requirement does not apply to UTRA FDD BS operating in band VIII.
	876 MHz to 915 MHz	-61 dBm	100 kHz	For the frequency range 880 MHz to 915 MHz, this requirement does not apply to UTRA FDD BS operating in band VIII, since it is already covered by the requirement in clause 4.2.4.2.4.
DCS1800	1 805 MHz to 1 880 MHz	-47 dBm	100 kHz	This requirement does not apply to UTRA FDD BS operating in band III.
	1 710 MHz to 1 785 MHz	-61 dBm	100 kHz	This requirement does not apply to UTRA FDD BS operating in band III, since it is already covered by the requirement in clause 4.2.4.2.4.
UTRA FDD Band I, E-UTRA Band 1	2 110 MHz to 2 170 MHz	-52 dBm	1 MHz	This requirement does not apply to UTRA FDD BS operating in band I.
	1 920 MHz to 1 980 MHz	-49 dBm	1 MHz	This requirement does not apply to UTRA FDD BS operating in band I, since it is already covered by the requirement in clause 4.2.4.2.4.
UTRA FDD Band III, E-UTRA Band 3	1 805 MHz to 1 880 MHz	-52 dBm	1 MHz	This requirement does not apply to UTRA BS operating in band III.
	1 710 MHz to 1 785 MHz	-49 dBm	1 MHz	This requirement does not apply to UTRA BS operating in band III, since it is already covered by the requirement in clause 4.2.4.2.4.
UTRA FDD Band VII, E-UTRA Band 7	2 620 MHz to 2 690 MHz	-52 dBm	1 MHz	This requirement does not apply to UTRA FDD BS operating in band VII, XV or XVI.
	2 500 MHz to 2 570 MHz	-49 dBm	1 MHz	This requirement does not apply to UTRA FDD BS operating in band VII, since it is already covered by the requirement in clause 4.2.4.2.4.
UTRA FDD Band VIII, E-UTRA Band 8	925 MHz to 960 MHz	-52 dBm	1 MHz	This requirement does not apply to UTRA FDD BS operating in band VIII.
	880 MHz to 915 MHz	-49 dBm	1 MHz	This requirement does not apply to UTRA FDD BS operating in band VIII, since it is already covered by the requirement in clause 4.2.4.2.4.
UTRA FDD Band XV	2 600 MHz to 2 620 MHz	-52 dBm	1 MHz	This requirement does not apply to UTRA FDD BS operating in band VII, XV or XVI.
	1 900 MHz to 1 920 MHz	-49 dBm	1 MHz	This requirement does not apply to UTRA FDD BS operating in band XV, since it is already covered by the requirement in clause 4.2.4.2.4.

Protected system	Frequency range for co-existence requirement	Maximum Level	Measurement Bandwidth	Note
UTRA FDD Band XVI	2 585 MHz to 2 600 MHz	-52 dBm	1 MHz	This requirement does not apply to UTRA FDD BS operating in band VII, XV or XVI.
	2 010 MHz to 2 025 MHz	-49 dBm	1 MHz	This requirement does not apply to UTRA FDD BS operating in band XVI, since it is already covered by the requirement in clause 4.2.4.2.4.
UTRA FDD Band XX, E-UTRA Band 20	791 MHz to 821 MHz	-52 dBm	1 MHz	This requirement does not apply to UTRA FDD BS operating in band XX.
	832 MHz to 862 MHz	-49 dBm	1 MHz	This requirement does not apply to UTRA FDD BS operating in band XX, since it is already covered by the requirement in clause 4.2.4.2.4.
UTRA FDD Band XXII, E-UTRA Band 22	3 510 MHz to 3 590 MHz	-52 dBm	1 MHz	This requirement does not apply to UTRA FDD BS operating in band XXII.
	3 410 MHz to 3 490 MHz	-49 dBm	1 MHz	This requirement does not apply to UTRA FDD BS operating in band XXII, since it is already covered by the requirement in clause 4.2.4.2.4.
UTRA FDD Band XXXII or E-UTRA Band 32	1 452 MHz – 1 496 MHz	-52 dBm	1 MHz	This requirement does not apply to UTRA BS operating in Band XXXII
UTRA TDD in Band a), E-UTRA Band 33	1 900 MHz to 1 920 MHz	-52 dBm	1 MHz	This requirement does not apply to UTRA FDD BS operating in band XV.
UTRA TDD in Band a), E-UTRA Band 34	2 010 MHz to 2 025 MHz	-52 dBm	1 MHz	This requirement does not apply to UTRA FDD BS operating in band XVI.
UTRA TDD in Band d), E-UTRA Band 38	2 570 MHz to 2 610 MHz	-52 dBm	1 MHz	This requirement does not apply to UTRA FDD BS operating in band XV or XVI.
E-UTRA Band 40	2 300 MHz to 2 400 MHz	-52 dBm	1 MHz	
E-UTRA Band 42	3 400 MHz to 3 600 MHz	-52 dBm	1 MHz	
E-UTRA Band 43	3 600 MHz to 3 800 MHz	-52 dBm	1 MHz	

NOTE: Where the table has two entries for the same or overlapping frequency ranges, both limits shall be applied.

4.2.4.2.3 Co-existence with services in adjacent frequency bands

This requirement shall be applied for the protection in bands adjacent to Operating Bands I and VII.

The power of any spurious emission shall not exceed the limits specified in table 4.2.4.2.3-1, depending on the declared operating band.

Table 4.2.4.2.3-1: Spurious emissions limits for protection of adjacent band services

Operating Band	Frequency range (f)	Maximum level	Measurement bandwidth
I	2 100 MHz to 2 105 MHz	-30 + 3,4 (f - 2 100 MHz) dBm	1 MHz
	2 175 MHz to 2 180 MHz	-30 + 3,4 (2 180 MHz - f) dBm	1 MHz

4.2.4.2.4 Protection of the BS receiver of own or different BS

This requirement shall be applied in order to prevent the receivers of the BSs being desensitized by emissions from a BS transmitter.

The power of any spurious emission shall not exceed the limit specified in tables 4.2.4.2.4-1, 4.2.4.2.4-2 or 4.2.4.2.4-3 depending on the declared Base Station class and operating band.

Table 4.2.4.2.4-1: Spurious emissions limits for protection of a Wide Area BS receiver

Operating band	Frequency range	Maximum level	Measurement bandwidth
I	1 920 MHz to 1 980 MHz	-96 dBm	100 kHz
III	1 710 MHz to 1 785 MHz	-96 dBm	100 kHz
VII	2 500 MHz to 2 570 MHz	-96 dBm	100 kHz
VIII	880 MHz to 915 MHz	-96 dBm	100 kHz
XV	1 900 MHz to 1 920 MHz	-96 dBm	100 kHz
XVI	2 010 MHz to 2 025 MHz	-96 dBm	100 kHz
XX	832 MHz to 862 MHz	-96 dBm	100 kHz
XXII	3 410 MHz to 3 490 MHz	-96 dBm	100 kHz

Table 4.2.4.2.4-2: Spurious emissions limits for protection of a Medium Range BS receiver

Operating band	Frequency range	Maximum level	Measurement bandwidth
I	1 920 MHz to 1 980 MHz	-86 dBm	100 kHz
III	1 710 MHz to 1 785 MHz	-86 dBm	100 kHz
VII	2 500 MHz to 2 570 MHz	-86 dBm	100 kHz
VIII	880 MHz to 915 MHz	-86 dBm	100 kHz
XV	1 900 MHz to 1 920 MHz	-86 dBm	100 kHz
XVI	2 010 MHz to 2 025 MHz	-86 dBm	100 kHz
XX	832 MHz to 862 MHz	-86 dBm	100 kHz
XXII	3 410 MHz to 3 490 MHz	-86 dBm	100 kHz

Table 4.2.4.2.4-3: Spurious emissions limits for protection of a Local Area BS and Home BS receiver

Operating band	Frequency range	Maximum level	Measurement bandwidth
I	1 920 MHz to 1 980 MHz	-82 dBm	100 kHz
III	1 710 MHz to 1 785 MHz	-82 dBm	100 kHz
VII	2 500 MHz to 2 570 MHz	-82 dBm	100 kHz
VIII	880 MHz to 915 MHz	-82 dBm	100 kHz
XV	1 900 MHz to 1 920 MHz	-82 dBm	100 kHz
XVI	2 010 MHz to 2 025 MHz	-82 dBm	100 kHz
XX	832 MHz to 862 MHz	-82 dBm	100 kHz
XXII	3 410 MHz to 3 490 MHz	-82 dBm	100 kHz

4.2.4.2.5 Co-existence with Home BS operating in other bands

These requirements shall be applied for the protection of Home BS receivers operating in other bands. These requirements are only applicable to Home BS.

The power of any spurious emission shall not exceed the limits of table 4.2.4.2.5-1 for a Home BS.

Table 4.2.4.2.5-1: Spurious emissions limits for protection of a Home BS receiver

Protected band	Frequency range	Maximum level	Measurement bandwidth
I	1 920 MHz to 1 980 MHz	-71 dBm	100 kHz
III	1 710 MHz to 1 785 MHz	-71 dBm	100 kHz
VII	2 500 MHz to 2 570 MHz	-71 dBm	100 kHz
VIII	880 MHz to 915 MHz	-71 dBm	100 kHz
XV	1 900 MHz to 1 920 MHz	-71 dBm	100 kHz
XVI	2 010 MHz to 2 025 MHz	-71 dBm	100 kHz
XX	832 MHz to 862 MHz	-71 dBm	100 kHz
XXII	3 410 MHz to 3 490 MHz	-71 dBm	100 kHz
UTRA TDD in Band a), E-UTRA Band 33	1 900 MHz to 1 920 MHz	-71 dBm	100 kHz
UTRA TDD in Band a), E-UTRA Band 34	2 010 MHz to 2 025 MHz	-71 dBm	100 kHz
UTRA TDD in Band d), E-UTRA Band 38	2 570 MHz to 2 610 MHz	-71 dBm	100 kHz
E-UTRA Band 40	2 300 MHz to 2 400 MHz	-71 dBm	100 kHz
E-UTRA Band 42	3 400 MHz to 3 600 MHz	-71 dBm	100 kHz
E-UTRA Band 43	3 600 MHz to 3 800 MHz	-71 dBm	100 kHz

4.2.4.3 Conformance

Conformance tests described in clause 5.3.3 shall be carried out.

4.2.5 Base Station maximum output power

4.2.5.1 Definition

Maximum output power, P_{max} , of the Base Station is the mean power level per carrier measured at the antenna connector in specified reference condition.

For a UTRA FDD BS additionally conforming to ETSI EN 301 908-18 [i.8], either the requirement of the present clause or the Base Station maximum output power requirement in clause 4.2.5 of ETSI EN 301 908-18 [i.8] can be equally applied, as listed in table 4.2.1-2.

4.2.5.2 Limit

In normal conditions, the Base Station maximum output power shall remain:

- within +2,7 dB and -2,7 dB of the manufacturer's rated output power, PRAT, for carrier frequency $f \leq 3,0$ GHz
- within +3,0 dB and -3,0 dB of the manufacturer's rated output power, PRAT, for carrier frequency $3,0$ GHz < $f \leq 4,2$ GHz.

In extreme conditions, the Base Station maximum output power shall remain:

- within +3,2 dB and -3,2 dB of the manufacturer's rated output power, PRAT, for carrier frequency $f \leq 3,0$ GHz
- within +3,5 dB and -3,5 dB of the manufacturer's rated output power, PRAT, for carrier frequency $3,0$ GHz < $f \leq 4,2$ GHz.

4.2.5.3 Conformance

Conformance tests described in clause 5.3.4 shall be carried out.

4.2.6 Transmitter intermodulation

4.2.6.1 Definition

The transmitter intermodulation requirement is a measure of the capability of the transmitter to inhibit the generation of signals in its non-linear elements caused by presence of the wanted signal and an interfering signal reaching the transmitter via the antenna.

The transmitter intermodulation level is the power of the intermodulation products when a WCDMA interfering signal is injected into an antenna connector at a mean power level of 30 dB lower than that of the mean power of the wanted signal.

For a UTRA FDD BS additionally conforming to ETSI EN 301 908-18 [i.8], either the requirement of the present clause or the Transmitter intermodulation requirement in clause 4.2.6 of ETSI EN 301 908-18 [i.8] can be equally applied, as listed in table 4.2.1-2.

For BS capable of multi-band operation where multiple bands are mapped on separate antenna connectors, the single-band requirements shall apply regardless of the interfering signals position relative to the inter-RF bandwidth gap.

For multi-carrier operation, the interfering signal offset is defined relative to the lower (upper) edge of the wanted signal or edge of sub-block inside a gap.

The interfering signal frequency offset shall be as in table 4.2.6.1-1.

Table 4.2.6.1-1: Interfering signal frequency offset

Parameter	Value
Interfering signal centre frequency offset from the wanted signal centre frequency	-5 MHz -10 MHz -15 MHz +5 MHz +10 MHz +15 MHz
Interfering signal centre frequency offset from the lower (upper) edge of the wanted signal or edge of sub-block inside a gap	-2,5 MHz -7,5 MHz -12,5 MHz +2,5 MHz +7,5 MHz +12,5 MHz
NOTE: Interference frequencies that are outside of any allocated frequency band for UTRA-FDD downlink specified in clause 1 are excluded from the requirement, unless the interfering signal positions fall within the frequency range of adjacent downlink operating bands in the same geographical area.	

For a BS operating in non-contiguous spectrum, the requirement is also applicable inside a sub-block gap for interfering signal offsets where the interfering signal falls completely within the sub-block gap. The interfering signal offset is defined relative to the sub-block edges.

For a BS capable of multi-band operation, the requirement is also applicable inside a inter RF bandwidth gap for interfering signal offsets where the interfering signal falls completely within the inter RF bandwidth gap. The interfering signal offset is defined relative to the RF bandwidth edges.

The measurements for out of band emission or spurious emission requirement due to intermodulation can be limited to the frequency ranges of all third and fifth order intermodulation products, considering the width of these products and excluding the bandwidths of the wanted and interfering signals.

4.2.6.2 Limit

In the frequency range relevant for this test, the transmit intermodulation level shall not exceed the out-of-band emission or the spurious emission requirements of clauses 4.2.2.2, 4.2.3.2 and 4.2.4.2 in the presence of a WCDMA interfering signal with a mean power level 30 dB lower than the mean power of the wanted signal.

4.2.6.3 Conformance

Conformance tests described in clause 5.3.5 shall be carried out.

4.2.7 Receiver spurious emissions

4.2.7.1 Definition

The spurious emission power is the power of the emissions, generated or amplified in a receiver, which appear at the BS antenna connector. The requirements shall apply to all BS with separate Rx and Tx antenna port. The test shall be performed when both Tx and Rx are on with the Tx port terminated.

For all BS with common Rx and Tx antenna port the transmitter spurious emission as specified in clause 4.2.4 is valid.

For a UTRA FDD BS additionally conforming to ETSI EN 301 908-18 [i.8], either the requirement of the present clause or the Receiver spurious emissions requirement in clause 4.2.7 of ETSI EN 301 908-18 [i.8] can be equally applied, as listed in table 4.2.1-2.

4.2.7.2 Limit

The power of any spurious emission shall not exceed the limit specified in table 4.2.7.2-1.

For BS capable of multi-band operation, the exclusions and conditions in the Note column of table 4.2.7.2-1 shall apply for each supported operating band. For BS capable of multi-band operation where multiple bands are mapped on separate antenna connectors, the single-band requirements shall apply and the excluded frequency range is only applicable for the operating band supported on each antenna connector.

In addition to the requirements in table 4.2.7.2-1, the power of any spurious emission shall not exceed the levels specified for protection of the BS receiver of own or different BS in clause 4.2.4.2.4, for co-existence with other systems in the same geographical area in clause 4.2.4.2.2 and for co-existence with services in adjacent frequency bands in clause 4.2.4.2.3.

Table 4.2.7.2-1: Spurious emission minimum requirement (general)

Frequency range	Maximum level	Measurement bandwidth	Note
30 MHz to 1 GHz	-57 dBm	100 kHz	With the exception of frequencies between 12,5 MHz below the first carrier frequency and 12,5 MHz above the last carrier frequency transmitted by the BS transmitter
1 GHz to 12,75 GHz	-47 dBm	1 MHz	
12,75 GHz to 5 th harmonic of the upper frequency edge of the UL operating band	-47 dBm	1 MHz	Applies only for Band XXII

4.2.7.3 Conformance

Conformance tests described in clause 5.3.6 shall be carried out.

4.2.8 Blocking characteristics

4.2.8.1 Definition

The blocking characteristics are a measure of the receiver ability to receive a wanted signal at its assigned channel frequency in the presence of an unwanted interferer on frequencies other than those of the adjacent channels. The interferences are either a WDCMA signal for in-band blocking or a CW signal for out-of-band blocking.

The blocking performance requirement shall apply as specified in tables 4.2.8.2-1, 4.2.8.2-2 or 4.2.8.2-3.

The requirements shall apply to the indicated base station class, depending on which frequency band is used.

For a UTRA FDD BS additionally conforming to ETSI EN 301 908-18 [i.8], either the requirement of the present clause or the In-band and Out-of-band blocking requirements in clauses 4.2.8 and 4.2.9 of ETSI EN 301 908-18 [i.8] can be equally applied, as listed in table 4.2.1-2.

4.2.8.2 Limit

For each measured carrier, the BER shall not exceed 0,001 for the parameters specified in tables 4.2.8.2-1, 4.2.8.2-2 or 4.2.8.2-3 depending on the declared Base Station class and operating band.

In addition for Base Stations operating in band III or VIII, the BER shall not exceed 0,001 for the parameters specified in tables 4.2.8.2-4, 4.2.8.2-5 or 4.2.8.2-6, depending on the declared Base Station class and operating band.

For a BS operating in non-contiguous spectrum within any operating band, the blocking requirement applies in addition inside any sub-block gap, in case the sub-block gap size is at least 15 MHz. The interfering signal offset is defined relative to the lower/upper sub-block edge inside the sub-block gap and is equal to -7,5 MHz/+7,5 MHz, respectively.

For a BS operating in non-contiguous spectrum within any operating band, the narrowband blocking requirements in tables 4.2.8.4-4 to 4.2.8.4-6 shall apply in addition inside any sub-block gap, in case the sub-block gap size is at least 400 kHz or 600 kHz, depending on the operating band. The interfering signal offset is defined relative to the lower/upper sub-block edge inside the sub-block gap and is equal to -200 kHz/+200 kHz or -300 kHz/+300 kHz, respectively.

For a BS capable of multi-band operation, the requirement in the in-band blocking frequency range shall apply for each supported operating band. The requirement shall apply in addition inside any inter RF bandwidth gap, in case the inter RF bandwidth gap size is at least 15 MHz. The interfering signal offset is defined relative to lower/upper RF bandwidth edges inside the inter RF bandwidth gap and is equal to -7,5 MHz/+7,5 MHz, respectively.

For a BS capable of multi-band operation, the requirement in the out-of-band blocking frequency ranges shall apply for each operating band, with the exception that the in-band blocking frequency ranges of all supported operating bands according to tables 4.2.8.4-1 to 4.2.8.4-3 shall be excluded from the out-of-band blocking requirement.

For a BS capable of multi-band operation, the narrowband blocking requirement shall apply in addition inside any inter RF bandwidth gap, in case the inter RF bandwidth gap size is at least 400 kHz or 600 kHz, depending on the operating band. The interfering signal offset is defined relative to lower/upper RF bandwidth edges inside the inter RF bandwidth gap and is equal to -200 kHz/+200 kHz or -300 kHz/+300 kHz, respectively.

Table 4.2.8.2-1: Blocking characteristics for Wide Area BS

Operating band	Centre frequency of interfering signal	Interfering signal mean power	Wanted signal mean power	Minimum offset of interfering signal	Type of interfering signal
I	1 920 MHz to 1 980 MHz	-40 dBm	-115 dBm	±10 MHz	WCDMA signal (see note 1)
	1 900 MHz to 1 920 MHz 1 980 MHz to 2 000 MHz	-40 dBm	-115 dBm	±10 MHz	WCDMA signal (see note 1)
	1 MHz to 1 900 MHz 2 000 MHz to 12 750 MHz	-15 dBm	-115 dBm	-	CW carrier
III	1 710 MHz to 1 785 MHz	-40 dBm	-115 dBm	±10 MHz	WCDMA signal (see note 1)
	1 690 MHz to 1 710 MHz 1 785 MHz to 1 805 MHz	-40 dBm	-115 dBm	±10 MHz	WCDMA signal (see note 1)
	1 MHz to 1 690 MHz 1 805 MHz to 12 750 MHz	-15 dBm	-115 dBm	-	CW carrier
VII	2 500 MHz to 2 570 MHz	-40 dBm	-115 dBm	±10 MHz	WCDMA signal (see note 1)
	2 480 MHz to 2 500 MHz 2 570 MHz to 2 590 MHz	-40 dBm	-115 dBm	±10 MHz	WCDMA signal (see note 1)
	1 MHz to 2 480 MHz 2 590 MHz to 12 750 MHz	-15 dBm	-115 dBm	-	CW carrier
VIII	880 MHz to 915 MHz	-40 dBm	-115 dBm	±10 MHz	WCDMA signal (see note 1)
	860 MHz to 880 MHz 915 MHz to 925 MHz	-40 dBm	-115 dBm	±10 MHz	WCDMA signal (see note 1)
	1 MHz to 860 MHz 925 MHz to 12 750 MHz	-15 dBm	-115 dBm	-	CW carrier
XV	1 900 MHz to 1 920 MHz	-40 dBm	-115 dBm	±10 MHz	WCDMA signal (see note 1)
	1 880 MHz to 1 900 MHz 1 920 MHz to 1 940 MHz	-40 dBm	-115 dBm	±10 MHz	WCDMA signal (see note 1)
	1 MHz to 1 880 MHz 1 940 MHz to 12 750 MHz	-15 dBm	-115 dBm	-	CW carrier
XV and I (see note 2)	1 900 MHz to 1 980 MHz	-40 dBm	-115 dBm	±10 MHz	WCDMA signal (see note 1)
	1 880 MHz to 1 900 MHz 1 980 MHz to 2 000 MHz	-40 dBm	-115 dBm	±10 MHz	WCDMA signal (see note 1)
	1 MHz to 1 880 MHz 2 000 MHz to 12 750 MHz	-15 dBm	-115 dBm	-	CW carrier
XVI	2 010 MHz to 2 025 MHz	-40 dBm	-115 dBm	±10 MHz	WCDMA signal (see note 1)
	1 990 MHz to 2 010 MHz 2 025 MHz to 2 045 MHz	-40 dBm	-115 dBm	±10 MHz	WCDMA signal (see note 1)
	1 MHz to 1 990 MHz 2 045 MHz to 12 750 MHz	-15 dBm	-115 dBm	-	CW carrier
XX	832 MHz to 862 MHz	-40 dBm	-115 dBm	±10 MHz	WCDMA signal (see note 1)
	821 MHz to 832 MHz 862 MHz to 882 MHz	-40 dBm	-115 dBm	±10 MHz	WCDMA signal (see note 1)
	1 MHz to 821 MHz 882 MHz to 12 750 MHz	-15 dBm	-115 dBm	-	CW carrier
XXII	3 410 MHz to 3 490 MHz	-40 dBm	-115 dBm	±10 MHz	WCDMA signal (see note 1)
	3 390 MHz to 3 410 MHz 3 490 MHz to 3 510 MHz	-40 dBm	-115 dBm	±10 MHz	WCDMA signal (see note 1)
	1 MHz to 3 390 MHz 3 510 MHz to 12 750 MHz	-15 dBm	-115 dBm	—	CW carrier

NOTE 1: The characteristics of the WCDMA interference signal are specified in ETSI TS 125 141 [2], annex I.

NOTE 2: This requirement applies for a BS supporting both Band XV and Band I.

NOTE 3: For a BS capable of multiband operation, in case of interfering signal that is not in the in-band blocking frequency range of the operating band where the wanted signal is present, the wanted Signal mean power is equal to -119,6 dBm.

NOTE 4: Table assumes that two operating bands, where the downlink frequencies (see table 1-1) of one band would be within the in-band blocking region of the other band, are not deployed in the same geographical area.

Table 4.2.8.2-2: Blocking characteristics for Medium Range BS

Operating band	Centre frequency of interfering signal	Interfering signal mean power	Wanted signal mean power	Minimum offset of interfering signal	Type of interfering signal
I	1 920 MHz to 1 980 MHz	-35 dBm	-105 dBm	±10 MHz	WCDMA signal (see note 1)
	1 900 MHz to 1 920 MHz 1 980 MHz to 2 000 MHz	-35 dBm	-105 dBm	±10 MHz	WCDMA signal (see note 1)
	1 MHz to 1 900 MHz 2 000 MHz to 12 750 MHz	-15 dBm	-105 dBm	-	CW carrier
III	1 710 MHz to 1 785 MHz	-35 dBm	-105 dBm	±10 MHz	WCDMA signal (see note 1)
	1 690 MHz to 1 710 MHz 1 785 MHz to 1 805 MHz	-35 dBm	-105 dBm	±10 MHz	WCDMA signal (see note 1)
	1 MHz to 1 690 MHz 1 805 MHz to 12 750 MHz	-15 dBm	-105 dBm	-	CW carrier
VII	2 500 MHz to 2 570 MHz	-35 dBm	-105 dBm	±10 MHz	WCDMA signal (see note 1)
	2 480 MHz to 2 500 MHz 2 570 MHz to 2 590 MHz	-35 dBm	-105 dBm	±10 MHz	WCDMA signal (see note 1)
	1 MHz to 2 480 MHz 2 590 MHz to 12 750 MHz	-15 dBm	-105 dBm	-	CW carrier
VIII	880 MHz to 915 MHz	-35 dBm	-105 dBm	±10 MHz	WCDMA signal (see note 1)
	860 MHz to 880 MHz 915 MHz to 925 MHz	-35 dBm	-105 dBm	±10 MHz	WCDMA signal (see note 1)
	1 MHz to 860 MHz 925 MHz to 12 750 MHz	-15 dBm	-105 dBm	-	CW carrier
XV	1 900 MHz to 1 920 MHz	-35 dBm	-105 dBm	±10 MHz	WCDMA signal (see note 1)
	1 880 MHz to 1 900 MHz 1 920 MHz to 1 940 MHz	-35 dBm	-105 dBm	±10 MHz	WCDMA signal (see note 1)
	1 MHz to 1 880 MHz 1 940 MHz to 12 750 MHz	-15 dBm	-105 dBm	-	CW carrier
XV and I (see note 2)	1 900 MHz to 1 980 MHz	-35 dBm	-105 dBm	±10 MHz	WCDMA signal (see note 1)
	1 880 MHz to 1 900 MHz 1 980 MHz to 2 000 MHz	-35 dBm	-105 dBm	±10 MHz	WCDMA signal (see note 1)
	1 MHz to 1 880 MHz 2 000 MHz to 12 750 MHz	-15 dBm	-105 dBm	-	CW carrier
XVI	2 010 MHz to 2 025 MHz	-35 dBm	-105 dBm	±10 MHz	WCDMA signal (see note 1)
	1 990 MHz to 2 010 MHz 2 025 MHz to 2 045 MHz	-35 dBm	-105 dBm	±10 MHz	WCDMA signal (see note 1)
	1 MHz to 1 990 MHz 2 045 MHz to 12 750 MHz	-15 dBm	-105 dBm	-	CW carrier
XX	832 MHz to 862 MHz	-35 dBm	-105 dBm	±10 MHz	WCDMA signal (see note 1)
	821 MHz to 832 MHz 862 MHz to 882 MHz	-35 dBm	-105 dBm	±10 MHz	WCDMA signal (see note 1)
	1 MHz to 821 MHz 882 MHz to 12 750 MHz	-15 dBm	-105 dBm	-	CW carrier
XXII	3 410 MHz to 3 490 MHz	-35 dBm	-105 dBm	±10 MHz	WCDMA signal (see note 1)
	3 390 MHz to 3 410 MHz 3 490 MHz to 3 510 MHz	-35 dBm	-105 dBm	±10 MHz	WCDMA signal (see note 1)
	1 MHz to 3 390 MHz 3 510 MHz to 12 750 MHz	-15 dBm	-105 dBm	—	CW carrier

NOTE 1: The characteristics of the WCDMA interference signal are specified in ETSI TS 125 141 [2], annex I.

NOTE 2: This requirement applies for a BS supporting both Band XV and Band I.

NOTE 3: For a BS capable of multiband operation, in case of interfering signal that is not in the in-band blocking frequency range of the operating band where the wanted signal is present, the wanted signal mean power is equal to -109,6 dBm.

NOTE 4: Table assumes that two operating bands, where the downlink frequencies (see table 1-1) of one band would be within the in-band blocking region of the other band, are not deployed in the same geographical area.

Table 4.2.8.2-3: Blocking characteristics for Local Area BS and Home BS

Operating band	Centre frequency of interfering signal	Interfering signal mean power	Wanted signal mean power	Minimum offset of interfering signal	Type of interfering signal
I	1 920 MHz to 1 980 MHz	-30 dBm	-101 dBm	±10 MHz	WCDMA signal (see note 1)
	1 900 MHz to 1 920 MHz 1 980 MHz to 2 000 MHz	-30 dBm	-101 dBm	±10 MHz	WCDMA signal (see note 1)
	1 MHz to 1 900 MHz 2 000 MHz to 12 750 MHz	-15 dBm	-101 dBm	-	CW carrier
III	1 710 MHz to 1 785 MHz	-30 dBm	-101 dBm	±10 MHz	WCDMA signal (see note 1)
	1 690 MHz to 1 710 MHz 1 785 MHz to 1 805 MHz	-30 dBm	-101 dBm	±10 MHz	WCDMA signal (see note 1)
	1 MHz to 1 690 MHz 1 805 MHz to 12 750 MHz	-15 dBm	-101 dBm	-	CW carrier
VII	2 500 MHz to 2 570 MHz	-30 dBm	-101 dBm	±10 MHz	WCDMA signal (see note 1)
	2 480 MHz to 2 500 MHz 2 570 MHz to 2 590 MHz	-30 dBm	-101 dBm	±10 MHz	WCDMA signal (see note 1)
	1 MHz to 2 480 MHz 2 590 MHz to 12 750 MHz	-15 dBm	-101 dBm	-	CW carrier
VIII	880 MHz to 915 MHz	-30 dBm	-101 dBm	±10 MHz	WCDMA signal (see note 1)
	860 MHz to 880 MHz 915 MHz to 925 MHz	-30 dBm	-101 dBm	±10 MHz	WCDMA signal (see note 1)
	1 MHz to 860 MHz 925 MHz to 12 750 MHz	-15 dBm	-101 dBm	-	CW carrier
XV	1 900 MHz to 1 920 MHz	-30 dBm	-101 dBm	±10 MHz	WCDMA signal (see note 1)
	1 880 MHz to 1 900 MHz 1 920 MHz to 1 940 MHz	-30 dBm	-101 dBm	±10 MHz	WCDMA signal (see note 1)
	1 MHz to 1 880 MHz 1 940 MHz to 12 750 MHz	-15 dBm	-101 dBm	-	CW carrier
XV and I (see note 2)	1 900 MHz to 1 980 MHz	-30 dBm	-101 dBm	±10 MHz	WCDMA signal (see note 1)
	1 880 MHz to 1 900 MHz 1 980 MHz to 2 000 MHz	-30 dBm	-101 dBm	±10 MHz	WCDMA signal (see note 1)
	1 MHz to 1 880 MHz 2 000 MHz to 12 750 MHz	-15 dBm	-101 dBm	-	CW carrier
XVI	2 010 MHz to 2 025 MHz	-30 dBm	-101 dBm	±10 MHz	WCDMA signal (see note 1)
	1 990 MHz to 2 010 MHz 2 025 MHz to 2 045 MHz	-30 dBm	-101 dBm	±10 MHz	WCDMA signal (see note 1)
	1 MHz to 1 990 MHz 2 045 MHz to 12 750 MHz	-15 dBm	-101 dBm	-	CW carrier
XX	832 MHz to 862 MHz	-30 dBm	-101 dBm	±10 MHz	WCDMA signal (see note 1)
	821 MHz to 832 MHz 862 MHz to 882 MHz	-30 dBm	-101 dBm	±10 MHz	WCDMA signal (see note 1)
	1 MHz to 821 MHz 882 MHz to 12 750 MHz	-15 dBm	-101 dBm	-	CW carrier
XXII	3 410 MHz to 3 490 MHz	-30 dBm	-101 dBm	±10 MHz	WCDMA signal (see note 1)
	3 390 MHz to 3 410 MHz 3 490 MHz to 3 510 MHz	-30 dBm	-101 dBm	±10 MHz	WCDMA signal (see note 1)
	1 MHz to 3 390 MHz 3 510 MHz to 12 750 MHz	-15 dBm	-101 dBm	—	CW carrier

NOTE 1: The characteristics of the WCDMA interference signal are specified in ETSI TS 125 141 [2], annex I.

NOTE 2: This requirement applies for a BS supporting both Band XV and Band I.

NOTE 3: For a BS capable of multiband operation, in case of interfering signal that is not in the in-band blocking frequency range of the operating band where the wanted signal is present, the wanted Signal mean power is equal to -105,6 dBm.

NOTE 4: Table assumes that two operating bands, where the downlink frequencies (see table 1-1) of one band would be within the in-band blocking region of the other band, are not deployed in the same geographical area.

**Table 4.2.8.2-4: Narrowband blocking characteristics for Wide Area BS
(operating band III and VIII)**

Operating band	Centre frequency of interfering signal	Interfering signal mean power	Wanted signal mean power	Minimum offset of interfering signal	Type of interfering signal
III	1 710 MHz to 1 785 MHz	-47 dBm	-115 dBm	±2,8 MHz	GMSK modulated (see note)
VIII	880 MHz to 915 MHz	-47 dBm	-115 dBm	±2,8 MHz	GMSK modulated (see note)

NOTE: GMSK modulation as defined in ETSI TS 145 004 [6].

**Table 4.2.8.2-5: Narrowband blocking characteristics for Medium Range BS
(operating band III and VIII)**

Operating band	Centre frequency of interfering signal	Interfering signal mean power	Wanted signal mean power	Minimum offset of interfering signal	Type of interfering signal
III	1 710 MHz to 1 785 MHz	-42 dBm	-105 dBm	±2,8 MHz	GMSK modulated (see note)
VIII	880 MHz to 915 MHz	-42 dBm	-105 dBm	±2,8 MHz	GMSK modulated (see note)

NOTE: GMSK modulation as defined in ETSI TS 145 004 [6].

**Table 4.2.8.2-6: Narrowband blocking characteristics for Local Area BS and Home BS
(operating band III and VIII)**

Operating band	Centre frequency of interfering signal	Interfering signal mean power	Wanted signal mean power	Minimum offset of interfering signal	Type of interfering signal
III	1 710 MHz to 1 785 MHz	-37 dBm	-101 dBm	±2,8 MHz	GMSK modulated (see note)
VIII	880 MHz to 915 MHz	-37 dBm	-101 dBm	±2,8 MHz	GMSK modulated (see note)

NOTE: GMSK modulation as defined in ETSI TS 145 004 [6].

4.2.8.3 Conformance

Conformance tests described in clause 5.3.7 shall be carried out.

4.2.9 Receiver intermodulation characteristics

4.2.9.1 Definition

Third and higher order mixing of the two interfering RF signals can produce an interfering signal in the band of the desired channel.

Intermodulation response rejection is a measure of the capability of the receiver to receive a wanted signal on its assigned channel frequency in the presence of two or more interfering signals which have a specific frequency relationship to the wanted signal.

For a UTRA FDD BS additionally conforming to ETSI EN 301 908-18 [i.8], either the requirement of the present clause or the Receiver intermodulation requirement in clause 4.2.10 of ETSI EN 301 908-18 [i.8] can be equally applied, as listed in table 4.2.1-2.

4.2.9.2 Limit

For each measured carrier, the BER shall not exceed 0,001 for the parameters specified in tables 4.2.9.2-1, 4.2.9.2-2 or 4.2.9.2-3, depending on the declared Base Station class.

In addition for Base Stations operating in band III or VIII, the BER for each measured carrier shall not exceed 0,001 for the parameters specified in tables 4.2.9.2-4, 4.2.9.2-5 or 4.2.9.2-6, depending on the declared Base Station class and operating band.

For a BS operating in non-contiguous spectrum within any operating band, the narrowband intermodulation requirement applies in addition inside any sub-block gap, in case the sub-block gap size is at least 6,8 MHz. The CW interfering signal offset is defined relative to the lower/upper sub-block edge inside the sub-block gap and is equal to -1 MHz/+1 MHz, respectively. The GMSK modulated interfering signal offset is defined relative to the lower/upper sub-block edge inside the sub-block gap and is equal to -3,4 MHz/+3,4 MHz, respectively. The requirement applies separately for both sub-blocks.

For a BS capable of multi-band operation, the narrowband intermodulation requirement applies in addition inside any inter RF bandwidth gap, in case the inter RF bandwidth gap size is at least 6,8 MHz. The CW interfering signal offset is defined relative to lower/upper RF bandwidth edges inside the inter RF bandwidth gap and is equal to -1 MHz/+1 MHz, respectively. The GMSK modulated interfering signal offset is defined relative to lower/upper RF bandwidth edges inside the inter RF bandwidth gap and is equal to -3,4 MHz/+3,4 MHz, respectively.

Table 4.2.9.2-1: Wide Area BS intermodulation performance requirement

Type of signal	Offset	Signal mean power
Wanted signal	-	-115 dBm
CW signal	±10 MHz	-48 dBm
WCDMA signal (see note)	±20 MHz	-48 dBm
NOTE: The characteristics of the WCDMA interference signal are specified in ETSI TS 125 141 [2], annex I.		

Table 4.2.9.2-2: Medium Range BS intermodulation performance requirement

Type of signal	Offset	Signal mean power
Wanted signal	-	-105 dBm
CW signal	±10 MHz	-44 dBm
WCDMA signal (see note)	±20 MHz	-44 dBm
NOTE: The characteristics of the WCDMA interference signal are specified in ETSI TS 125 141 [2], annex I.		

Table 4.2.9.2-3: Local Area BS and Home BS intermodulation performance requirement

Type of signal	Offset	Signal mean power
Wanted signal	-	-101 dBm
CW signal	±10 MHz	-38 dBm
WCDMA signal (see note)	±20 MHz	-38 dBm
NOTE: The characteristics of the WCDMA interference signal are specified in ETSI TS 125 141 [2], annex I.		

Table 4.2.9.2-4: Wide Area BS narrowband intermodulation performance requirement (operating band III and VIII)

Type of signal	Offset	Signal mean power
Wanted signal	-	-115 dBm
CW signal	±3,5 MHz	-47 dBm
GMSK signal (see note)	±5,9 MHz	-47 dBm
NOTE: GMSK modulation as defined in ETSI TS 145 004 [6].		

Table 4.2.9.2-5: Medium Range BS narrowband intermodulation performance requirement (operating band III and VIII)

Type of signal	Offset	Signal mean power
Wanted signal	-	-105 dBm
CW signal	$\pm 3,5$ MHz	-43 dBm
GMSK signal (see note)	$\pm 5,9$ MHz	-43 dBm
NOTE: GMSK modulation as defined in ETSI TS 145 004 [6].		

Table 4.2.9.2-6: Local Area BS and Home BS narrowband intermodulation performance requirement (operating band III and VIII)

Type of signal	Offset	Signal mean power
Wanted signal	-	-101 dBm
CW signal	$\pm 3,5$ MHz	-37 dBm
GMSK signal (see note)	$\pm 5,9$ MHz	-37 dBm
NOTE: GMSK modulation as defined in ETSI TS 145 004 [6].		

4.2.9.3 Conformance

Conformance tests described in clause 5.3.8 shall be carried out.

4.2.10 Receiver adjacent channel selectivity

4.2.10.1 Definition

Adjacent Channel Selectivity (ACS) is a measure of the receiver's ability to receive a wanted signal at its assigned channel frequency in the presence of an adjacent channel signal at a given frequency offset from the centre frequency of the assigned channel. ACS is the ratio of the receiver filter attenuation on the assigned channel frequency to the receive filter attenuation on the adjacent channel(s).

The interference signal is offset from the wanted signal by the frequency offset F_{uw} . The interference signal shall be a WCDMA signal as specified in ETSI TS 125 141 [2], annex I.

For a UTRA FDD BS additionally conforming to ETSI EN 301 908-18 [i.8], either the requirement of the present clause or the Narrowband blocking requirement in clause 4.2.11 of ETSI EN 301 908-18 [i.8] can be equally applied, as listed in table 4.2.1-2.

4.2.10.2 Limit

For each measured carrier, the BER shall not exceed 0,001 using the parameters specified in tables 4.2.10.2-1, 4.2.10.2-2, 4.2.10.2-3 and/or 4.2.10.2-4 depending on the declared Base Station class.

For multi-carrier BS the ACS requirement is applicable outside the Base Station RF bandwidth or maximum radio bandwidth edges. The interfering signal offset is defined relative to the lower (upper) or maximum radio bandwidth edges.

For a BS operating in non-contiguous spectrum within any operating band, the requirement shall apply in addition inside any sub-block gap, in case the sub-block gap size is at least 5 MHz. The interfering signal offset is defined relative to the lower/upper sub-block edge inside the sub-block gap and is equal to $-2,5$ MHz/ $+2,5$ MHz, respectively.

For a BS capable of multi-band operation, the requirement applies in addition inside any inter RF bandwidth gap, in case the inter RF bandwidth gap size is at least 5 MHz. The interfering signal offset is defined relative to lower/upper RF bandwidth edges inside the inter RF bandwidth gap and is equal to $-2,5$ MHz/ $+2,5$ MHz, respectively.

Table 4.2.10.2-1: Adjacent channel selectivity for Wide Area BS

Parameter	Level	Unit
Reference measurement channel data rate	12,2	kbit/s
Wanted signal mean power	-115	dBm
Interfering signal mean power	-52	dBm
F_{uw} offset (modulated)	± 5	MHz

Table 4.2.10.2-2: Adjacent channel selectivity for Medium Range BS

Parameter	Level	Unit
Reference measurement channel data rate	12,2	kbit/s
Wanted signal mean power	-105	dBm
Interfering signal mean power	-42	dBm
F_{uw} offset (modulated)	± 5	MHz

Table 4.2.10.2-3: Adjacent channel selectivity for Local Area BS and Home BS

Parameter	Level	Unit
Reference measurement channel data rate	12,2	kbit/s
Wanted signal mean power	-101	dBm
Interfering signal mean power	-38	dBm
F_{uw} offset (modulated)	± 5	MHz

Table 4.2.10.2-4: Adjacent channel selectivity for Home BS (additional requirement)

Parameter	Level	Unit
Reference measurement channel data rate	12,2	kbit/s
Wanted signal mean power	-91	dBm
Interfering signal mean power	-28	dBm
F_{uw} offset (modulated)	± 5	MHz
NOTE: This additional requirement for Home BS ensures the performance is met over a large dynamic range.		

4.2.10.3 Conformance

Conformance tests described in clause 5.3.9 shall be carried out.

4.2.11 Home BS output power for adjacent channel protection

4.2.11.1 Definition

The Home BS shall be capable of adjusting the transmitter output power to minimize the interference level on the adjacent channels while optimize the Home BS coverage, in case an adjacent channel is licensed to another operator in the same geographical area. These requirements are only applicable to Home BS. The requirements in this clause are applicable for AWGN radio propagation conditions.

4.2.11.2 Limit

The output power, P_{out} , of the Home BS shall be as specified in table 4.2.11.2-1 under the following input conditions:

- $CPICH \hat{E}_c$, measured in dBm, is the code power of the Primary CPICH on one of the adjacent channels presented at the Home BS antenna connector for the CPICH received on the adjacent channels. If Tx diversity is applied on the Primary CPICH, $CPICH \hat{E}_c$ shall be the sum (in W) of the code powers of the Primary CPICH transmitted from each antenna.

- I_{oh} , measured in dBm, is the total received power density, including signals and interference but excluding the own Home BS signal, presented at the Home BS antenna connector on the Home BS operating channel.

The input conditions defined for the requirements in this clause are specified at the antenna connector of the Home BS. For Home BS receivers with diversity, the requirements apply to each antenna connector separately, with the other one(s) terminated or disabled. The requirements are otherwise unchanged. For Home BS(s) without measurement capability, a reference antenna with a gain of 0 dBi is assumed for converting these power levels into field strength requirements.

Table 4.2.11.2-1: Home BS output power for adjacent operator channel protection

Input Conditions	Output power, P_{out} (without transmit diversity or any MIMO mode)	Output power, P_{out} (with transmit diversity or MIMO mode)	Output power, P_{out} (with MIMO mode with four transmit antennas)
$I_{oh} > CPICH \hat{E}_c + 43$ dB and $CPICH \hat{E}_c \geq -105$ dBm	≤ 10 dBm	≤ 7 dBm	≤ 4 dBm
$I_{oh} \leq CPICH \hat{E}_c + 43$ dB and $CPICH \hat{E}_c \geq -105$ dBm	$\leq \max(8 \text{ dBm}, \min(20 \text{ dBm},$ $CPICH \hat{E}_c + 100 \text{ dB}))$	$\leq \max(5 \text{ dBm}, \min(17 \text{ dBm},$ $CPICH \hat{E}_c + 97 \text{ dB}))$	$\leq \max(2 \text{ dBm},$ $\min(14 \text{ dBm}, CPICH \hat{E}_c +$ $94 \text{ dB}))$
$CPICH \hat{E}_c < -105$ dBm	≤ 20 dBm	≤ 17 dBm	≤ 14 dBm

In normal operating conditions, the output power, P_{out} , of the Home BS shall be equal to or less than the value specified in table 4.2.11.2-1 plus 2,7 dB.

In extreme operating conditions, the output power, P_{out} , of the Home BS shall be equal to or less than the value specified in table 4.2.11.2-1 plus 3,2 dB.

4.2.11.3 Conformance

Conformance tests described in clause 5.3.10 shall be carried out.

5 Testing for compliance with technical requirements

5.1 Environmental conditions for testing

Tests defined in the present document shall be carried out at representative points within the boundary limits of the declared operational environmental profile.

Where technical performance varies subject to environmental conditions, tests shall be carried out under a sufficient variety of environmental conditions (within the boundary limits of the declared operational environmental profile) to give confidence of compliance for the affected technical requirements.

Normally it should be sufficient for all tests to be conducted using normal test conditions except where otherwise stated. For guidance on the use of other test conditions to be used in order to show compliance reference can be made to ETSI TS 125 141 [2], clause 4.4.

The measurement system required for each test is described in ETSI TS 125 141 [2], annex B.

NOTE: In normal operating conditions the BS is configured to transmit and receive at the same time. The transmitter may be off for some of the tests as specified in ETSI TS 125 141 [2].

5.2 Interpretation of the measurement results

The interpretation of the results recorded in a test report for the measurements described in the present document shall be as follows:

- the measured value related to the corresponding limit shall be used to decide whether equipment meets the requirements of the present document;

- the value of the measurement uncertainty for the measurement of each parameter shall be documented in the test report;
- the recorded value of the measurement uncertainty shall be, for each measurement, equal to or lower than the figures in table 5.2-1.

For the test methods, according to the present document, the measurement uncertainty figures shall be calculated and shall correspond to an expansion factor (coverage factor) $k = 1,96$ (which provides a confidence level of 95 % in the case where the distributions characterizing the actual measurement uncertainties are normal (Gaussian)). Principles for the calculation of measurement uncertainty are contained in ETSI TR 100 028 [i.6], in particular in annex D of the ETSI TR 100 028-2 [i.6].

Table 5.2-1 is based on this expansion factor.

In all the relevant clauses in this clause all Bit Error Ratio (BER) measurements shall be carried out according to the general rules for statistical testing defined in Recommendation ITU-T O.153 [4] and ETSI TS 125 141 [2], annex C.

Table 5.2-1: Maximum uncertainty of the test system

Parameter	Conditions	Uncertainty
Spectrum emissions mask		$\pm 1,5$ dB, $f \leq 3,0$ GHz $\pm 1,8$ dB, $3,0$ GHz $< f \leq 4,2$ GHz
Adjacent Channel Leakage power Ratio (ACLR)	ACLR limit CAACLR Adjacent channel power limit Absolute limit for Home BS $\pm 1,5$ dB, $f \leq 3,0$ GHz Absolute limit for Home BS $\pm 1,8$ dB, $3,0$ GHz $< f \leq 4,2$ GHz	$\pm 0,8$ dB $\pm 0,8$ dB $\pm 2,0$ dB
Transmitter spurious emissions	For general requirements: $f \leq 2,2$ GHz $2,2$ GHz $< f \leq 4$ GHz 4 GHz $< f < 19$ GHz For co-existence requirements for > -60 dBm: $f \leq 3,0$ GHz $3,0$ GHz $< f \leq 4,2$ GHz for ≤ -60 dBm: $f \leq 3,0$ GHz $3,0$ GHz $< f \leq 4,2$ GHz For protection of the BS receiver	$\pm 1,5$ dB $\pm 2,0$ dB $\pm 4,0$ dB $\pm 2,0$ dB $\pm 2,5$ dB, $\pm 3,0$ dB $\pm 3,5$ dB $\pm 3,0$ dB
Base Station maximum output power, Home BS output power for adjacent channel protection		$\pm 0,7$ dB, $f \leq 3,0$ GHz $\pm 1,0$ dB, $3,0$ GHz $< f \leq 4,2$ GHz
Transmit intermodulation	For spectrum emissions mask For ACLR For "Spurious emissions": $f \leq 2,2$ GHz $2,2$ GHz $< f \leq 4$ GHz $f > 4$ GHz For co-existence requirements Interference signal	$\pm 2,5$ dB $\pm 2,2$ dB $\pm 2,5$ dB $\pm 2,8$ dB $\pm 4,5$ dB $\pm 2,8$ dB $\pm 1,0$ dB
Receiver spurious emissions	For BS receive bands (-78 dBm) $f \leq 3,0$ GHz $3,0$ GHz $< f \leq 4,2$ GHz Outside the BS receive bands: $f \leq 2,2$ GHz $2,2$ GHz $< f \leq 4$ GHz 4 GHz $< f < 19$ GHz	$\pm 3,0$ dB $\pm 3,5$ dB $\pm 2,0$ dB $\pm 2,0$ dB $\pm 4,0$ dB

Parameter	Conditions	Uncertainty
Blocking characteristics	For offset < 15 MHz	$\pm 1,4$ dB
	For offset ≥ 15 MHz and:	
	$f \leq 2,2$ GHz	$\pm 1,1$ dB
	$2,2$ GHz < $f \leq 4$ GHz	$\pm 1,8$ dB
Receiver intermodulation characteristics	$f > 4$ GHz	$\pm 3,2$ dB
		$\pm 1,3$ dB, $f \leq 3,0$ GHz
Receiver Adjacent Channel Selectivity (ACS)		$\pm 2,3$ dB, $3,0$ GHz < $f \leq 4,2$ GHz
		$\pm 1,1$ dB, $f \leq 3,0$ GHz
		$\pm 1,5$ dB, $3,0$ GHz < $f \leq 4,2$ GHz
NOTE 1: For RF tests it should be noted that the uncertainties in table 5.2-1 apply to the test system operating into a nominal 50 Ω load and do not include system effects due to mismatch between the EUT and the test system.		
NOTE 2: Annex G of ETSI TR 100 028-2 [6] provides guidance for the calculation of the uncertainty components relating to mismatch.		
NOTE 3: If the test system for a test is known to have a measurement uncertainty greater than that specified in table 5.2-1, this equipment can still be used, provided that an adjustment is made as follows: any additional uncertainty in the test system over and above that specified in table 5.2-1 is used to tighten the test requirements - making the test harder to pass (for some tests, e.g. receiver tests, this may require modification of stimulus signals). This procedure will ensure that a test system not compliant with table 5.2-1 does not increase the probability of passing an EUT that would otherwise have failed a test if a test system compliant with table 5.2-1 had been used.		

5.3 Essential radio test suites

5.3.0 Introduction

This clause describes the test suites for UTRA FDD.

The test configurations and channel spacing for multi-carrier operations shall be used for demonstrating conformance are specified in clauses 4.12 and 3.5.1 of ETSI TS 125 141 [2].

For the single carrier testing many tests in the present document are performed with appropriate frequencies in the bottom, middle and top of the operating band of the BS. These are denoted as RF channels B (bottom), M (middle) and T (top) and are defined in ETSI TS 125 141 [2], clause 4.8.

For single-band multi-carrier testing many tests in the present document are performed with the maximum RF bandwidth position located at the bottom, middle and top of the supported frequency range in each operating band. These are denoted as B_{RFBW} (bottom), M_{RFBW} (middle) and T_{RFBW} (top) for non-aggregated channels and are defined in ETSI TS 125 141 [2], clause 4.8.1.

For dual-band testing many tests in the present document are performed with the RF bandwidths located at bottom of the supported frequency range in the lower operating band and at the top of the supported frequency range in the upper operating band. These are denoted as $B_{RFBW_T'_{RFBW}}$ and $B'_{RFBW_T_{RFBW}}$ and are defined in ETSI TS 125 141 [2], clause 4.8.1. The measurement system required for each test is described in ETSI TS 125 141 [2], annex B.

5.3.1 Spectrum emission mask

5.3.1.0 General

For a UTRA FDD BS additionally conforming to ETSI EN 301 908-18 [i.8], either the test suite of the present clause or the Operating band unwanted emissions test suite in clause 5.3.1 of ETSI EN 301 908-18 [i.8] can be equally applied, as listed in table 4.2.1-2.

5.3.1.1 Initial conditions

Test environment: Normal; see ETSI TS 125 141 [2], clause 4.4.1.

RF channels to be tested for single carrier operation: B, M and T; see clause 5.1.

RF bandwidth positions to be tested for multi-carrier operation:

- B_{RFBW} , M_{RFBW} and T_{RFBW} in single-band operation; see clause 5.1.
 - $B_{\text{RFBW}}T_{\text{RFBW}}$ and $B'_{\text{RFBW}}T_{\text{RFBW}}$ in multi-band operation; see clause 5.1.
- 1) Set-up the equipment as shown in ETSI TS 125 141 [2], annex B.
As a general rule, the resolution bandwidth of the measuring equipment should be equal to the measurement bandwidth. However, to improve measurement accuracy, sensitivity, efficiency and avoiding e.g. carrier leakage, the resolution bandwidth may be smaller than the measurement bandwidth. When the resolution bandwidth is smaller than the measurement bandwidth, the result should be integrated over the measurement bandwidth in order to obtain the equivalent noise bandwidth of the measurement bandwidth.
 - 2) Measurements with an offset from the carrier centre frequency between 2,515 MHz and 4,0 MHz shall use a 30 kHz measurement bandwidth.
 - 3) Measurements with an offset from the carrier centre frequency between 4,0 MHz and $(f_{\text{offset}_{\text{max}}} - 500 \text{ kHz})$ shall use a 1 MHz measurement bandwidth.
 - 4) Detection mode: true RMS voltage or true average power.

5.3.1.2 Procedures

- 1) For a BS declared to be capable of single carrier operation only, set the base station to transmit a signal according to test model TM1, as defined in ETSI TS 125 141 [2], at manufacturer's declared rated output power, PRAT.

For a BS declared to be capable of multi-carrier operation, set the base station to transmit according to TM1 on all carriers configured using the applicable test configuration and corresponding power setting specified in ETSI TS 125 141 [2] clause 4.12.

- 2) Step the centre frequency of the measurement filter in contiguous steps and measure the emission within the specified frequency ranges with the specified measurement bandwidth.

In addition, for a multi-band capable BS, the following steps shall apply:

- 3) For multi-band capable BS and single-band tests, repeat the steps above per involved band where single-band test configurations and test models shall apply with no carrier activated in the other band.
- 4) For multi-band capable BS with separate antenna connector, the antenna connector not being under test in case of single-band or multi-band test shall be terminated.

The results obtained shall be compared to the limits in clause 4.2.2.2 in order to prove compliance.

5.3.2 Adjacent Channel Leakage power Ratio (ACLR)

5.3.2.1 Initial conditions

Test environment: Normal; see ETSI TS 125 141 [2], clause 4.4.1.

RF channels to be tested for single carrier operation: B, M and T; see clause 5.1.

RF bandwidth positions to be tested for multi-carrier operation:

- B_{RFBW} , M_{RFBW} and T_{RFBW} in single-band operation; see clause 5.1.
 - $B_{\text{RFBW}}T_{\text{RFBW}}$ and $B'_{\text{RFBW}}T_{\text{RFBW}}$ in multi-band operation; see clause 5.1.
- 1) Connect measurement device to the Base Station antenna connector as shown in ETSI TS 125 141 [2], annex B.
 - 2) The measurement device characteristics shall be:
 - measurement filter bandwidth: defined in clause 4.2.3.1;

- detection mode: true RMS voltage or true average power.
- 3) For a BS declared to be capable of single carrier operation only, set the base station to transmit a signal according to test model TM1, as defined in ETSI TS 125 141 [2], at manufacturer's declared rated output power, PRAT.

For a BS declared to be capable of multi-carrier operation, set the base station to transmit according to TM1 on all carriers configured using the applicable test configuration and corresponding power setting specified in ETSI TS 125 141 [2] clause 4.12.

- 4) Set carrier frequency within the frequency band supported by BS. Minimum carrier spacing shall be 5 MHz and maximum carrier spacing shall be specified by manufacturer.

5.3.2.2 Procedure

- 1) Measure ACLR and Adjacent channel power for 5 MHz and 10 MHz offsets both side of channel frequency. In multiple carrier case only offset frequencies below the lowest and above the highest carrier frequency transmitted shall be measured.
- 2) For the ACLR requirement applied inside sub-block gap for non-contiguous spectrum operation or inside inter RF bandwidth gap for multi-band operation:
 - a) Measure ACLR inside sub-block gap or inter RF bandwidth gap as specified in clause 4.2.3.2, if applicable.
 - b) Measure Cumulative Adjacent Channel Leakage power Ratio (CACLR) inside sub-block gap or inter RF bandwidth gap as specified in clause 4.2.3.3, if applicable.

In addition, for a multi-band capable BS, the following steps shall apply:

- 3) For multi-band capable BS and single-band tests, repeat the steps above per involved band where single-band test configurations and test models shall apply with no carrier activated in the other band.
- 4) For multi-band capable BS with separate antenna connector, the antenna connector not being under test in case of single-band or multi-band test shall be terminated.

The results obtained shall be compared to the limits in clause 4.2.3.2 in order to prove compliance.

5.3.3 Transmitter spurious emissions

5.3.3.0 General

For a UTRA FDD BS additionally conforming to ETSI EN 301 908-18 [i.8], either the test suite of the present clause or the Transmitter spurious emissions test suite in clause 5.3.3 of ETSI EN 301 908-18 [i.8] can be equally applied, as listed in table 4.2.1-2.

5.3.3.1 Initial conditions

Test environment: Normal; see ETSI TS 125 141 [2], clause 4.4.1.

RF channels to be tested for single carrier operation: B, M and T; see clause 5.1.

RF bandwidth positions to be tested for multi-carrier operation:

- B_{RFBW} , M_{RFBW} and T_{RFBW} in single-band operation; see clause 5.1.
 - $B_{RFBW_T_{RFBW}}$ and $B'_{RFBW_T_{RFBW}}$ in multi-band operation; see clause 5.1.
- 1) Connect the BS antenna connector to a measurement receiver using an attenuator or a directional coupler if necessary.
 - 2) Measurements shall use a measurement bandwidth in accordance to the tables in clause 4.2.4.2.
 - 3) Detection mode: true RMS voltage or true average power.

5.3.3.2 Procedure

- 1) For a BS declared to be capable of single carrier operation only, set the base station to transmit a signal according to test model TM1, as defined in ETSI TS 125 141 [2], at manufacturer's declared rated output power, PRAT.

For a BS declared to be capable of multi-carrier operation, set the base station to transmit according to TM1 on all carriers configured using the applicable test configuration and corresponding power setting specified in ETSI TS 125 141 [2] clause 4.12.

- 2) Measure the emission at the specified frequencies with specified measurement bandwidth and note that the measured value does not exceed the specified value.

In addition, for a multi-band capable BS, the following steps shall apply:

- 3) For multi-band capable BS and single-band tests, repeat the steps above per involved band where single-band test configurations and test models shall apply with no carrier activated in the other band.
- 4) For multi-band capable BS with separate antenna connector, the antenna connector not being under test in case of single-band or multi-band test shall be terminated.

The results obtained shall be compared to the limits in clause 4.2.4.2 in order to prove compliance.

5.3.4 Base Station maximum output power

5.3.4.0 General

For a UTRA FDD BS additionally conforming to ETSI EN 301 908-18 [i.8], either the test suite of the present clause or the Base Station maximum output power test suite in clause 5.3.4 of ETSI EN 301 908-18 [i.8] can be equally applied, as listed in table 4.2.1-2.

5.3.4.1 Initial conditions

Test environment: Normal; see ETSI TS 125 141 [2], clause 4.4.1.

RF channels to be tested for single carrier operation: B, M and T; see clause 5.1.

RF bandwidth positions to be tested for multi-carrier operation:

- B_{RFBW} , M_{RFBW} and T_{RFBW} in single-band operation; see clause 5.1;
- B'_{RFBW} , T'_{RFBW} and B'_{RFBW} , T'_{RFBW} in multi-band operation; see clause 5.1.

In addition, on one UARFCN only, the test shall be performed under extreme power supply as defined in ETSI TS 125 141 [2], clause 4.4.4.

NOTE: Tests under extreme power supply also test extreme temperature.

- 1) Connect the power measuring equipment to the Base Station antenna connector.

5.3.4.2 Procedure

- 1) For a BS declared to be capable of single carrier operation only, set the base station to transmit a signal according to test model TM1, as defined in ETSI TS 125 141 [2], at manufacturer's declared rated output power, PRAT.

For a BS declared to be capable of multi-carrier operation, set the base station to transmit according to TM1 on all carriers configured using the applicable test configuration and corresponding power setting specified in ETSI TS 125 141 [2] clause 4.12.

- 2) Measure the mean power for each carrier, P_{out} , at the antenna connector.

In addition, for a multi-band capable BS, the following steps shall apply:

- 3) For multi-band capable BS and single-band tests, repeat the steps above per involved band where single-band test configurations and test models shall apply with no carrier activated in the other band.
- 4) For multi-band capable BS with separate antenna connector, the antenna connector not being under test in case of single-band or multi-band test shall be terminated.

The results obtained shall be compared to the limits in clause 4.2.5.2 in order to prove compliance.

5.3.5 Transmit intermodulation

5.3.5.0 General

For a UTRA FDD BS additionally conforming to ETSI EN 301 908-18 [i.8], either the test suite of the present clause or the Transmitter intermodulation test suite in clause 5.3.5 of ETSI EN 301 908-18 [i.8] can be equally applied, as listed in table 4.2.1-2.

5.3.5.1 Initial conditions

Test environment: Normal; see ETSI TS 125 141 [2], clause 4.4.1.

RF channels to be tested for single carrier operation: B, M and T; see clause 5.1.

RF bandwidth positions to be tested for multi-carrier operation:

- B_{RFBW} , M_{RFBW} and T_{RFBW} in single-band operation; see clause 5.1.
 - $B_{\text{RFBW}}T_{\text{RFBW}}$ and $B'_{\text{RFBW}}T_{\text{RFBW}}$ in multi-band operation; see clause 5.1.
- 1) Test set-up in accordance to ETSI TS 125 141 [2], annex B.

5.3.5.2 Procedures

- 1) For a BS declared to be capable of single carrier operation only, set the base station to transmit a signal according to test model TM1, as defined in ETSI TS 125 141 [2], at manufacturer's declared rated output power, PRAT.

For a BS declared to be capable of multi-carrier operation, set the base station to transmit according to TM1 on all carriers configured using the applicable test configuration and corresponding power setting specified in ETSI TS 125 141 [2] clause 4.12.

- 2) Generate the interference signal in accordance to test model TM1 in ETSI TS 125 141 [2], with a frequency offset according to the conditions of table 4.2.6.1-1, 48 but exclude interfering frequencies that are outside of the allocated downlink operating band or interfering frequencies that are not completely within the sub-block gap or within the inter-RF bandwidth gap.
- 3) Adjust ATT1 so the level of the WCDMA-modulated interfering signal at BS is 30 dB below the wanted signal.
- 4) Perform the out-of-band emission tests as specified in clauses 5.3.1 and 5.3.2 for all third and fifth order intermodulation products which appear in the frequency ranges defined in clauses 5.3.1 and 5.3.2. The width of the intermodulation products shall be taken into account.
- 5) Perform the spurious emission test as specified in clause 5.3.3 for all third and fifth order intermodulation products which appear in the frequency ranges defined in clause 5.3.3. The width of the intermodulation products shall be taken into account.
- 6) Verify that the emission level does not exceed the required level with the exception of interference signal frequencies.
- 7) Repeat the test for the remaining interference frequency off-sets according to the conditions of table 4.2.6.1-1.

In addition, for a multi-band capable BS, the following steps shall apply:

- 8) For multi-band capable BS and single-band tests, repeat the steps above per involved band where single-band test configurations and test models shall apply with no carrier activated in the other band.
- 9) For multi-band capable BS with separate antenna connector, the antenna connector not being under test shall be terminated.

NOTE: The third order intermodulation products are $(F1 \pm 2F2)$ and $(2F1 \pm F2)$, the fifth order intermodulation products are $(2F1 \pm 3F2)$, $(3F1 \pm 2F2)$, $(4F1 \pm F2)$, and $(F1 \pm 4F2)$, where $F1$ represents the subject signal frequencies of 5 MHz channel and $F2$ represents the interference signal frequencies of 5 MHz channel. The width of intermodulation products is 15 MHz for third order intermodulation products and 25 MHz for fifth order intermodulation products based on a bandwidth of 5 MHz for subject and interference signal.

The results obtained shall be compared to the limits in clause 4.2.6.2 in order to prove compliance.

5.3.6 Receiver spurious emissions

5.3.6.0 General

For a UTRA FDD BS additionally conforming to ETSI EN 301 908-18 [i.8], either the test suite of the present clause or the Receiver spurious emissions test suite in clause 5.3.6 of ETSI EN 301 908-18 [i.8] can be equally applied, as listed in table 4.2.1-2.

5.3.6.1 Initial conditions

Test environment: Normal; see ETSI TS 125 141 [2], clause 4.4.1.

RF channels to be tested for single carrier operation: M, with multi-carrier if supported; see clause 5.1.

RF bandwidth positions to be tested for multi-carrier operation:

- B_{RFBW} , M_{RFBW} and T_{RFBW} in single-band operation; see clause 5.1.
- $B_{RFBW_T'_{RFBW}}$ and $B'_{RFBW_T_{RFBW}}$ in multi-band operation; see clause 5.1.

Connect a measurement receiver to the BS antenna connector as shown in ETSI TS 125 141 [2], annex B.

5.3.6.2 Procedure

- 1) For a BS declared to be capable of single carrier operation only, set the base station to transmit a signal according to test model TM1, as defined in ETSI TS 125 141 [2], at manufacturer's declared rated output power, PRAT.

For a BS declared to be capable of multi-carrier operation, set the base station to transmit according to TM1 on all carriers configured using the applicable test configuration and corresponding power setting for receiver tests, as specified in ETSI TS 125 141 [2] clause 4.12.

- 2) Set measurement equipment parameters as specified in table 5.3.6.2-1.

Table 5.3.6.2-1: Measurement equipment parameters

Measurement bandwidth	as in table 4.2.7.2-1
Sweep frequency range	30 MHz to 12,75 GHz
Detection	true RMS voltage or true average power

- 3) Measure the spurious emissions over each frequency range described in clause 4.2.7.2.

In addition, for a multi-band capable BS, the following steps shall apply:

- 4) For multi-band capable BS and single-band tests, repeat the steps above per involved band where single-band test configurations and test models shall apply with no carrier activated in the other band.
- 5) For multi-band capable BS with separate antenna connector, the antenna connector not being under test in case of single-band or multi-band test shall be terminated.

The results obtained shall be compared to the limits in clause 4.2.7.2 in order to prove compliance.

5.3.7 Blocking characteristics

5.3.7.0 General

For a UTRA FDD BS additionally conforming to ETSI EN 301 908-18 [i.8], either the test suite of the present clause or the In-band and Out-of-band blocking test suites in clauses 5.3.7 and 5.3.8 of ETSI EN 301 908-18 [i.8] can be equally applied, as listed in table 4.2.1-2.

5.3.7.1 Initial conditions

Test environment: Normal; see ETSI TS 125 141 [2], clause 4.4.1.

RF channels to be tested for single carrier operation: M; see clause 5.1. The BS shall be configured to operate as close to the centre of the operating band as possible.

RF bandwidth positions to be tested for multi-carrier operation:

- B_{RFBW} , M_{RFBW} and T_{RFBW} in single-band operation; see clause 5.1;
- $B_{\text{RFBW}}\text{-}T'_{\text{RFBW}}$ and $B'_{\text{RFBW}}\text{-}T_{\text{RFBW}}$ in multi-band operation; see clause 5.1.

In addition, in multi-band operation:

- For $B_{\text{RFBW}}\text{-}T'_{\text{RFBW}}$, out-of-band blocking testing above the highest operating band may be omitted.
 - For $B'_{\text{RFBW}}\text{-}T_{\text{RFBW}}$, out-of-band blocking testing below the lowest operating band may be omitted.
- 1) Connect WCDMA signal generator at the assigned channel frequency of the wanted signal and a signal generator to the antenna connector of one Rx port.
 - 2) Transmit a signal from the WCDMA signal generator to the BS. The characteristics of the signal shall be set according to the UL reference measurement channel (12,2 kbit/s) specified in ETSI TS 125 141 [2], clause A.2.1. The level of the WCDMA signal measured at the BS antenna connector shall be set to the level specified in clause 4.2.8.2. For a BS supporting multi-carrier operation, generate the wanted signal according to the applicable test configuration (see clause 4.12 in ETSI TS 125 141 [2]) using applicable reference measurement channel to the BS under test. Power settings are specified in clause 4.2.6.2.
 - 3) For a BS declared to be capable of single carrier operation only, set the base station to transmit a signal according to test model TM1, as defined in ETSI TS 125 141 [2], at manufacturer's declared rated output power, PRAT.

For a BS declared to be capable of multi-carrier operation, set the base station to transmit according to TM1 on all carriers configured using the applicable test configuration and corresponding power setting for receiver tests, as specified in ETSI TS 125 141 [2] clause 4.12.

In addition, for a multi-band capable BS with separate antenna connectors, the following steps shall apply:

- 4) For single-band tests, repeat the steps above per involved band where single-band test configurations and test models shall apply with no carrier activated in the other band.
- 5) The interfering signal shall first be applied on the same port as the wanted signal. The test shall be repeated with the interfering signal applied on the other port (if any) mapped to the same receiver as the wanted signal. Any antenna connector with no signal applied in case of single-band or multi-band test shall be terminated.

- 6) Repeat step 5) with the wanted signal for the other band(s) applied on the respective port(s).

The transmitter may be turned off for the out-of-band blocker tests when the frequency of the blocker is such that no IM2 or IM3 products fall inside the bandwidth of the wanted signal.

5.3.7.2 Procedure

- 1) Set the signal generator to produce an interfering signal at a frequency offset F_{uw} from the assigned channel frequency of the wanted signal which is given by:

$$F_{uw} = \pm(n \times 1 \text{ MHz});$$

where n shall be increased in integer steps from $n = 10$ up to such a value that the centre frequency of the interfering signal covers the range from 1 MHz to 12,75 GHz. The interfering signal level measured at the antenna connector shall be set in dependency of its centre frequency, as specified in tables 4.2.8.2-1 to 4.2.8.2-6. The type of the interfering signal is either equivalent to a continuous WCDMA signal with one code of chip frequency 3,84 Mchip/s, filtered by an RRC transmit pulse-shaping filter with roll-off $\alpha = 0,22$, a CW signal or a GMSK modulated signal; see tables 4.2.8.2-1 to 4.2.8.2-6.

For narrowband blocking, the GMSK modulated interfering signal shall have an ACLR of at least 72 dB in order to eliminate the impact of interference signal adjacent channel leakage power on the intermodulation characteristics measurement.

- 2) Measure the BER of the wanted signal at the BS receiver. For a BS supporting multi-carrier operation the BER shall be measured for all relevant carriers specified by the test configuration.

NOTE: ETSI TS 125 141 [2], annex C describes the procedure for BER tests taking into account the statistical consequence of frequent repetition of BER measurements within the blocking test. The consequence is: a DUT exactly on the limit may fail due to the statistical nature 2,55 times (mean value) in 12 750 BER measurements using the predefined wrong decision probability of 0,02 %. If the fail cases are ≤ 12 , it is allowed to repeat the fail cases one time before the final verdict.

The results obtained shall be compared to the limits in clause 4.2.8.2 in order to prove compliance.

5.3.8 Receiver intermodulation characteristics

5.3.8.0 General

For a UTRA FDD BS additionally conforming to ETSI EN 301 908-18 [i.8], either the test suite of the present clause or the Receiver intermodulation test suite in clause 5.3.9 of ETSI EN 301 908-18 [i.8] can be equally applied, as listed in table 4.2.1-2.

5.3.8.1 Initial conditions

Test environment: Normal; see ETSI TS 125 141 [2], clause 4.4.1.

RF channels to be tested for single carrier operation: B, M and T; see clause 5.1.

RF bandwidth positions to be tested for multi-carrier operation:

- B_{RFBW} , M_{RFBW} and T_{RFBW} in single-band operation; see clause 5.1;
- $B_{RFBW_T'_{RFBW}}$ and $B'_{RFBW_T_{RFBW}}$ in multi-band operation; see clause 5.1.

- 1) Set-up the equipment as shown in ETSI TS 125 141 [2], annex B.

5.3.8.2 Procedures

- 1) Generate the wanted signal (reference signal) and adjust ATT1 to set the signal level to the BS under test to the level specified in tables 4.2.9.2-1 to 4.2.9.2-6.

For a BS supporting multi-carrier operation, generate the wanted signal according to the applicable test configuration (see clause 4.12 in ETSI TS 125 141 [2]) using applicable reference measurement channel to the BS under test. Power settings are specified in tables 4.2.9.2-1 to 4.2.9.2-6.

- 2) Adjust the signal generators to type of interfering signal and frequency offset from the frequency of the wanted signal, as specified in tables 4.2.9.2-1 to 4.2.9.2-6. The type of the interfering signal is either equivalent to a continuous WCDMA signal with one code of chip frequency 3,84 Mchip/s, filtered by an RRC transmit pulse-shaping filter with roll-off $\alpha = 0,22$, a CW signal or a GMSK modulated signal; see tables 4.2.9.2-1 to 4.2.9.2-6.

For narrowband blocking, the GMSK modulated interfering signal shall have an ACLR of at least 72 dB in order to eliminate the impact of interference signal adjacent channel leakage power on the intermodulation characteristics measurement.

- 3) Adjust the ATT2 and ATT3 to obtain the specified level of interference signal at the BS input.
- 4) Measure the BER of the wanted signal. For a BS supporting multi-carrier operation the BER shall be measured for all relevant carriers specified by the test configuration.

In addition, for a multi-band capable BS with separate antenna connectors, the following steps shall apply:

- 5) For single-band tests, repeat the steps above per involved band where single-band test configurations shall apply with no carrier activated in the other band.
- 6) The interfering signal shall first be applied on the same port as the wanted signal. The test shall be repeated with the interfering signal applied on the other port (if any) mapped to the same receiver as the wanted signal. Any antenna connector with no signal applied in case of single-band or multi-band test shall be terminated.
- 7) Repeat the previous step with the wanted signal for the other band(s) applied on the respective port(s).

The results obtained shall be compared to the limits in clause 4.2.9.2 in order to prove compliance.

5.3.9 Adjacent Channel Selectivity (ACS)

5.3.9.0 General

For a UTRA FDD BS additionally conforming to ETSI EN 301 908-18 [i.8], either the test suite of the present clause or the Narrowband blocking test suite in clause 5.3.10 of ETSI EN 301 908-18 [i.8] can be equally applied, as listed in table 4.2.1-2.

5.3.9.1 Initial conditions

Test environment: Normal; see ETSI TS 125 141 [2], clause 4.4.1.

RF channels to be tested for single carrier operation: B, M and T; see clause 5.1.

RF bandwidth positions to be tested for multi-carrier operation:

- B_{RFBW} , M_{RFBW} and T_{RFBW} in single-band operation; see clause 5.1.
- $B_{\text{RFBW_T'_{RFBW}}}$ and $B'_{\text{RFBW_T'_{RFBW}}}$ in multi-band operation; see clause 5.1.

- 1) Set-up the equipment as shown in ETSI TS 125 141 [2], annex B.

5.3.9.2 Procedure

- 1) Generate the wanted signal and adjust the ATT1 to set the input level to the Base Station under test to the level specified in tables 4.2.10.2-1 to 4.2.10.2-4.

For a BS supporting multi-carrier operation, generate the wanted signal according to the applicable test configuration (see clause 4.12 in ETSI TS 125 141 [2]) using applicable reference measurement channel to the BS under test. Power settings are specified in tables 4.2.10.2-1 to 4.2.10.2-4.

- 2) Set-up the interference signal at the adjacent channel frequency and adjust the ATT2 to obtain the specified level of interference signal at the Base Station input defined in tables 4.2.10.2-1 to 4.2.10.2-4. Note that the interference signal shall have an ACLR of at least 63 dB in order to eliminate the impact of interference signal adjacent channel leakage power on the ACS measurement.
- 3) Measure the BER of the wanted signal. For a BS supporting multi-carrier operation the BER shall be measured for all relevant carriers specified by the test configuration.

In addition, for a multi-band capable BS with separate antenna connectors, the following steps shall apply:

- 4) For single-band tests, repeat the steps above per involved band where single-band test configurations shall apply with no carrier activated in the other band.
- 5) The interfering signal shall first be applied on the same port as the wanted signal. The test shall be repeated with the interfering signal applied on the other port (if any) mapped to the same receiver as the wanted signal. Any antenna connector with no signal applied in case of single-band or multi-band test shall be terminated.
- 6) Repeat the previous step with the wanted signal for the other band(s) applied on the respective port(s).

The results obtained shall be compared to the limits in clause 4.2.10.2 in order to prove compliance.

5.3.10 Home BS output power for adjacent channel protection

5.3.10.1 Initial conditions

Test environment: Normal; see ETSI TS 125 141 [2], clause 4.4.1.

RF channels to be tested: M; see clause 5.1.

- 1) Set-up the equipment as shown in ETSI TS 125 141 [2], annex B.
- 2) The Home BS is configured such that the adjacent channel is known to belong to another operator.

5.3.10.2 Procedure

- 1) Connect the combined downlink interfering signals (referred to as point D in figure B.7 of ETSI TS 125 141 [2]) to the dedicated measurement port (referred to as point 1 in figure B.7 of ETSI TS 125 141 [2]) if available, otherwise connect to point 2.
- 2) Configure the signal generator for co-channel interference to transmit AWGN over a 3,84 MHz bandwidth centred on RF channel M.
- 3) Configure the signal generator for adjacent channel DL signal to transmit test model TM1 in ETSI TS 125 141 [2] at the centre frequency equal to RF channel M + 5 MHz.
- 4) Switch on signal generators delivering co-channel and adjacent channel interferers, and adjust the ATT1 and ATT2 such that CPICH $\hat{E}_c = -80$ dBm and $I_{oh} = -50$ dBm.
- 5) Trigger the Home BS power adjustment mechanism.
- 6) Set the Home BS to transmit a signal in accordance to test model TM1 in ETSI TS 125 141 [2].

NOTE: The signal is transmitted with the maximum allowed output power.

- 7) Measure Home BS output power, P_{out} , and check it is below the required value according to the CPICH \hat{E}_c and I_{oh} values determined in step 4.
- 8) Repeat steps 3) to 7) with the frequency in step 3 set to RF channel M - 5 MHz.
- 9) Repeat steps 3) to 8) with different settings for ATT1 and ATT2 to arrive the CPICH \hat{E}_c and I_{oh} pairs as specified in table 5.3.10.2-1.

Table 5.3.10.2-1: Test parameter settings

Test Case	CPICH \bar{E}_c (dBm)	loh (dBm)
1	-80	-50
2	-90	-60
3	-100	-70
4	-100	-50

The results obtained shall be compared to the limits in clause 4.2.11.2 in order to prove compliance.

Annex A (normative): HS Requirements and conformance Test specifications Table (HS-RTT)

The HS Requirements and conformance Test specifications Table (HS-RTT) in table A-1 serves a number of purposes, as follows:

- it provides a statement of all the requirements in words and by cross reference to (a) specific clause(s) in the present document or to (a) specific clause(s) in (a) specific referenced document(s);
- it provides a statement of all the test procedures corresponding to those requirements by cross reference to (a) specific clause(s) in the present document or to (a) specific clause(s) in (a) specific referenced document(s);
- it qualifies each requirement to be either:
 - Unconditional: meaning that the requirement applies in all circumstances; or
 - Conditional: meaning that the requirement is dependent on the manufacturer having chosen to support optional functionality defined within the schedule.
- in the case of Conditional requirements, it associates the requirement with the particular optional service or functionality;
- it qualifies each test procedure to be either:
 - Essential: meaning that it is included with the Essential Radio Test Suite and therefore the requirement shall be demonstrated to be met in accordance with the referenced procedures;
 - Other: meaning that the test procedure is illustrative but other means of demonstrating compliance with the requirement are permitted.

Table A-1: HS Requirements and conformance Test specifications Table (HS-RTT)

Harmonized Standard ETSI EN 301 908-3						
The following requirements and test specifications are relevant to the presumption of conformity under the article 3.2 of the R&TTE Directive [i.2]						
Requirement			Requirement Conditionality		Test Specification	
No	Description	Reference: Clause No	U/C	Condition	E/O	Reference: Clause No
1	Spectrum emissions mask	4.2.2	U		E	5.3.1
2	Adjacent channel leakage power ratio (ACLR)	4.2.3	U		E	5.3.2
3	Transmitter spurious emissions	4.2.4	U		E	5.3.3
4	Base Station maximum output power	4.2.5	U		E	5.3.4
5	Transmit intermodulation	4.2.6	U		E	5.3.5
6	Receiver spurious emissions	4.2.7	U		E	5.3.6
7	Blocking characteristics	4.2.8	U		E	5.3.7
8	Receiver intermodulation characteristics	4.2.9	U		E	5.3.8
9	Receiver adjacent channel selectivity (ACS)	4.2.10	U		E	5.3.9
10	Home BS output power for adjacent channel protection	4.2.11	C	Applies to BS declared as Home Base Station.	E	5.3.10

Key to columns:**Requirement:**

No A unique identifier for one row of the table which may be used to identify a requirement or its test specification.

Description A textual reference to the requirement.

Clause Number Identification of clause(s) defining the requirement in the present document unless another document is referenced explicitly.

Requirement Conditionality:

U/C Indicates whether the requirement is to be *unconditionally* applicable (U) or is *conditional* upon the manufacturers claimed functionality of the equipment (C).

Condition Explains the conditions when the requirement shall or shall not be applicable for a requirement which is classified "conditional".

Test Specification:

E/O Indicates whether the test specification forms part of the Essential Radio Test Suite (E) or whether it is one of the Other Test Suite (O).

NOTE: All tests whether "E" or "O" are relevant to the requirements. Rows designated "E" collectively make up the Essential Radio Test Suite; those designated "O" make up the Other Test Suite; for those designated "X" there is no test specified corresponding to the requirement. The completion of all tests classified "E" as specified with satisfactory outcomes is a necessary condition for a presumption of conformity. Compliance with requirements associated with tests classified "O" or "X" is a necessary condition for presumption of conformity, although conformance with the requirement may be claimed by an equivalent test or by manufacturer's assertion supported by appropriate entries in the technical construction file.

Clause Number Identification of clause(s) defining the test specification in the present document unless another document is referenced explicitly. Where no test is specified (that is, where the previous field is "X") this field remains blank.

Annex B (normative): Base Station configurations

B.1 Receiver diversity

For the tests in clause 5 of the present document, the requirement shall apply at each receiver antenna connector for receivers with antenna diversity.

Receiver requirements are tested at the antenna connector, with the remaining receiver(s) disabled or their antenna connector(s) being terminated. If the manufacturer has declared the receiver paths to be equivalent, it is sufficient to apply the specified test signal at any one of the receiver antenna connectors.

For a multi-band BS, multi-band tests for ACS, blocking and intermodulation are performed with the interferer(s) applied to each antenna connector mapped to the receiver for the wanted signal(s), however only to one antenna at a time. Antenna connectors to which no signals are applied are terminated.

B.2 Duplexers

The requirements of the present document shall be met with a duplexer fitted, if a duplexer is supplied as part of the BS. If the duplexer is supplied as an option by the manufacturer, sufficient tests should be repeated with and without the duplexer fitted to verify that the BS meets the requirements of the present document in both cases.

The following tests should be performed with the duplexer fitted, and without it fitted if this is an option:

- 1) clause 5.3.4, Base Station maximum output power, for the highest static power step only, if this is measured at the antenna connector;
- 2) clause 5.3.3, output RF spectrum emissions; outside the BS transmit band;
- 3) clause 5.3.5, transmit intermodulation; for the testing of conformance, the carrier frequencies should be selected to minimize intermodulation products from the transmitters falling in receive channels. The remaining tests may be performed with or without the duplexer fitted.

NOTE 1: When performing receiver tests with a duplexer fitted, it is important to ensure that the output from the transmitters does not affect the test apparatus. This can be achieved using a combination of attenuators, isolators and filters.

NOTE 2: When duplexers are used, intermodulation products will be generated, not only in the duplexer but also in the antenna system. The intermodulation products generated in the antenna system are not controlled by the specifications, and may degrade during operation (e.g. due to moisture ingress). Therefore, to ensure continued satisfactory operation of a BS, an operator will normally select UARFCNs to minimize intermodulation products falling on receive channels. For testing of complete conformance, an operator may specify the UARFCNs to be used.

B.3 Power supply options

If the BS is supplied with a number of different power supply configurations, it may not be necessary to test RF parameters for each of the power supply options, provided that it can be demonstrated that the range of conditions over which the equipment is tested is at least as great as the range of conditions due to any of the power supply configurations.

This applies particularly if a BS contains a DC rail which can be supplied either externally or from an internal mains power supply. In this case, the conditions of extreme power supply for the mains power supply options can be tested by testing only the external DC supply option. The range of DC input voltages for the test should be sufficient to verify the performance with any of the power supplies, over its range of operating conditions within the BS, including variation of mains input voltage, temperature and output current.

B.4 Ancillary RF amplifiers

The requirements of the present document shall be met with the ancillary RF amplifier fitted. At tests according to clause 5, the ancillary amplifier is connected to the BS by a connecting network (including any cable(s), attenuator(s), etc.) with applicable loss to make sure the appropriate operating conditions of the ancillary amplifier and the BS. The applicable connecting network loss range is declared by the manufacturer. Other characteristics and the temperature dependence of the attenuation of the connecting network are neglected. The actual attenuation value of the connecting network is chosen for each test as one of the applicable extreme values. The lowest value is used unless otherwise stated.

Sufficient tests should be repeated with the ancillary amplifier fitted and, if it is optional, without the ancillary RF amplifier to verify that the BS meets the requirements of the present document in both cases.

When testing, the following tests should be repeated with the optional ancillary amplifier fitted according to table B.4-1, where x denotes that the test is applicable.

Table B.4-1: Table of tests applicable to Ancillary RF Amplifiers

	Clause	Tx amplifier only	Rx amplifier only	Tx/Rx amplifiers combined (see note)
Receiver Tests	5.3.7		X	X
	5.3.8		X	X
	5.3.6		X	
Transmitter Tests	5.3.4	X		X
	5.3.2	X		X
	5.3.3	X		X
	5.3.5	X		X
NOTE: Combining can be by duplex filters or any other network. The amplifiers can either be in Rx or Tx branch or in both. Either one of these amplifiers could be a passive network.				

In test according to clause 5.3.4, the highest applicable attenuation value is applied.

B.5 BS using antenna arrays

B.5.0 Introduction

A BS may be configured with a multiple antenna port connection for some or all of its transceivers or with an antenna array related to one cell (not one array per transceiver). This clause applies to a BS which meets at least one of the following conditions:

- the transmitter output signals from one or more transceiver appear at more than one antenna port; or
- there is more than one receiver antenna port for a transceiver or per cell and an input signal is required at more than one port for the correct operation of the receiver thus the outputs from the transmitters as well as the inputs to the receivers are directly connected to several antennas (known as "aircombining"); or

NOTE: Diversity reception does not meet this requirement.

- transmitters and receivers are connected via duplexers to more than one antenna.

In case of diversity or MIMO, multiple antennas are not considered as an antenna array.

If a BS is used, in normal operation, in conjunction with an antenna system which contains filters or active elements which are necessary to meet the UTRA requirements, the conformance tests may be performed on a system comprising the BS together with these elements, supplied separately for the purposes of testing. In this case, it shall be demonstrated that the performance of the configuration under test is representative of the system in normal operation, and the conformance assessment is only applicable when the BS is used with the antenna system.

For conformance testing of such a BS, the following procedure may be used.

B.5.1 Receiver tests

For each test, the test signals applied to the receiver antenna connectors shall be such that the sum of the powers of the signals applied equals the power of the test signal(s) specified in the test.

An example of a suitable test configuration is shown in figure B.5.1-1.

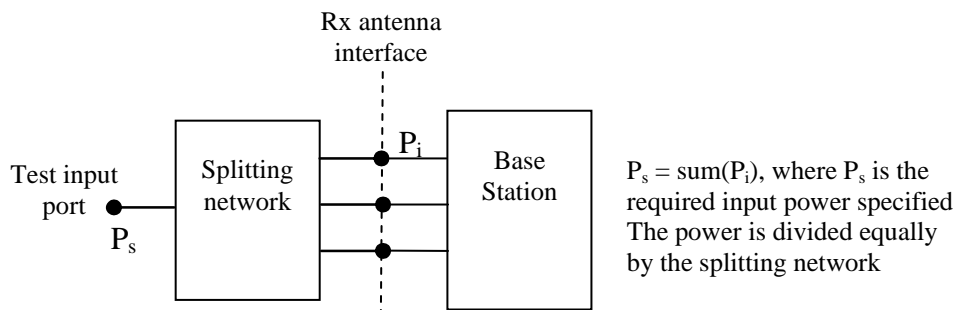

Figure B.5.1-1: Receiver test set-up

For spurious emissions from the receiver antenna connector, the test may be performed separately for each receiver antenna connector.

B.5.2 Transmitter tests

For each test, the test signals applied to the transmitter antenna connectors (P_i) shall be such that the sum of the powers of the signals applied equals the power of the test signal(s) (P_s) specified in the test. This may be assessed by separately measuring the signals emitted by each antenna connector and summing the results, or by combining the signals and performing a single measurement. The characteristics (e.g. amplitude and phase) of the combining network should be such that the power of the combined signal is maximized.

An example of a suitable test configuration is shown in figure B.5.2-1.

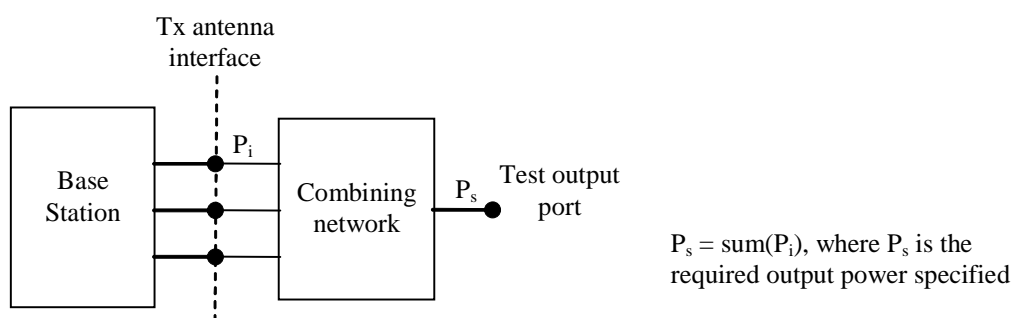

Figure B.5.2-1: Transmitter test set-up

For intermodulation attenuation, the test may be performed separately for each transmitter antenna connector.

B.6 Transmit diversity and MIMO transmission

Unless otherwise stated, for the tests in clause 5, the requirement shall apply for each transmitter antenna connector in case of transmit diversity, DB-DC-HSDPA or MIMO transmission.

Transmitter requirements are tested at the antenna connector, with the remaining antenna connector(s) being terminated. If the manufacturer has declared the transmitter paths to be equivalent, it is sufficient to measure the signal at any one of the transmitter antenna connectors.

B.7 BS with integrated Iuant BS modem

Unless otherwise stated, for the tests in the present document, the integrated Iuant BS modem shall be switched off. Spurious emissions according to clauses 5.3.3 and 5.3.6 shall be measured only for frequencies above 20 MHz with the integrated Iuant BS modem switched on.

Annex C (informative): Environmental profile specification

The following environmental conditions may be declared by the supplier:

- barometric pressure: minimum and maximum;
- temperature: minimum and maximum;
- relative humidity: minimum and maximum;
- power supply: lower and upper voltage limit.

When operating outside the boundary limits of the declared operational environmental profile the equipment should not make ineffective use of the radio frequency spectrum so as to cause harmful interference.

Annex D:
Void

Annex E (informative): Bibliography

- Directive 2004/108/EC of the European Parliament and of the Council of 15 December 2004 on the approximation of the laws of the Member States relating to electromagnetic compatibility and repealing Directive 89/336/EEC (EMC Directive).
- Directive 2006/95/EC of the European Parliament and of the Council of 12 December 2006 on the harmonisation of the laws of Member States relating to electrical equipment designed for use within certain voltage limits (LV Directive).
- CEPT/ERC/REC 74-01 (Siófok 1998, Nice 1999, Sesimbra 2002, Hradec Kralove 2005, Cardiff 2011): "Unwanted Emissions in the Spurious Domain".
- Commission Decision 2008/477/EC of 13 June 2008 on the harmonisation of the 2 500-2 690 MHz frequency band for terrestrial systems capable of providing electronic communications services in the Community.
- Commission Decision 2010/267/EU of 6 May 2010 on harmonised technical conditions of use in the 790-862 MHz frequency band for terrestrial systems capable of providing electronic communications services in the European Union.

History

Document history		
V1.1.1	January 2002	Publication
V2.2.1	October 2003	Publication
V3.2.1	May 2007	Publication
V4.2.1	March 2010	Publication
V5.2.1	July 2011	Publication
V6.2.1	October 2013	Publication
V6.4.2	January 2015	EN Approval Procedure AP 20150530: 2015-01-30 to 2015-06-01