

ETSI EN 301 893 V1.2.3 (2003-08)

Candidate Harmonized European Standard (Telecommunications series)

**Broadband Radio Access Networks (BRAN);
5 GHz high performance RLAN;
Harmonized EN covering essential requirements
of article 3.2 of the R&TTE Directive**



Reference

DEN/BRAN-0020002-2

Keywords

access, broadband, HIPERLAN, LAN, layer 1,
radio, testing

ETSI

650 Route des Lucioles
F-06921 Sophia Antipolis Cedex - FRANCE

Tel.: +33 4 92 94 42 00 Fax: +33 4 93 65 47 16

Siret N° 348 623 562 00017 - NAF 742 C
Association à but non lucratif enregistrée à la
Sous-Préfecture de Grasse (06) N° 7803/88

Important notice

Individual copies of the present document can be downloaded from:

<http://www.etsi.org>

The present document may be made available in more than one electronic version or in print. In any case of existing or perceived difference in contents between such versions, the reference version is the Portable Document Format (PDF). In case of dispute, the reference shall be the printing on ETSI printers of the PDF version kept on a specific network drive within ETSI Secretariat.

Users of the present document should be aware that the document may be subject to revision or change of status. Information on the current status of this and other ETSI documents is available at

<http://portal.etsi.org/tb/status/status.asp>

If you find errors in the present document, send your comment to:

editor@etsi.org

Copyright Notification

No part may be reproduced except as authorized by written permission.
The copyright and the foregoing restriction extend to reproduction in all media.

© European Telecommunications Standards Institute 2003.
All rights reserved.

DECTTM, **PLUGTESTS**TM and **UMTS**TM are Trade Marks of ETSI registered for the benefit of its Members.
TIPHONTM and the **TIPHON logo** are Trade Marks currently being registered by ETSI for the benefit of its Members.
3GPPTM is a Trade Mark of ETSI registered for the benefit of its Members and of the 3GPP Organizational Partners.

Contents

Intellectual Property Rights	6
Foreword.....	6
Introduction	7
1 Scope	9
2 References	10
3 Definitions, symbols and abbreviations	10
3.1 Definitions	10
3.2 Symbols.....	11
3.3 Abbreviations	11
4 Technical requirements specifications	12
4.1 Environmental profile.....	12
4.2 Carrier frequencies	12
4.2.1 Definition.....	12
4.2.2 Limits.....	12
4.2.3 Conformance.....	12
4.3 RF output power, Transmit Power Control (TPC) and power density	12
4.3.1 Definition.....	12
4.3.2 Limits.....	12
4.3.2.1 RF output power and power density at the highest power level.....	12
4.3.2.2 RF output power at the lowest power level.....	13
4.3.3 Conformance.....	13
4.4 Transmitter unwanted emissions	13
4.4.1 Transmitter unwanted emissions outside the 5 GHz RLAN bands.....	13
4.4.1.1 Definition	13
4.4.1.2 Limits	13
4.4.1.3 Conformance.....	13
4.4.2 Transmitter unwanted emissions within the 5 GHz RLAN bands	13
4.4.2.1 Definition	13
4.4.2.2 Limits	14
4.4.2.3 Conformance.....	14
4.5 Receiver spurious emissions.....	14
4.5.1 Definition.....	14
4.5.2 Limits.....	14
4.5.3 Conformance.....	14
4.6 Dynamic Frequency Selection (DFS).....	14
4.6.1 Interference Detection Threshold	16
4.6.1.1 Definition	16
4.6.1.2 Limit.....	16
4.6.1.3 Conformance.....	16
4.6.2 Channel Availability Check Time	16
4.6.2.1 Definition	16
4.6.2.2 Limit.....	16
4.6.2.3 Conformance.....	16
4.6.3 Channel Closing Transmission Time	16
4.6.3.1 Definition	16
4.6.3.2 Limit.....	16
4.6.3.3 Conformance.....	17
4.6.4 Channel Move Time	17
4.6.4.1 Definition	17
4.6.4.2 Limit.....	17
4.6.4.3 Conformance.....	17
4.6.5 Uniform Spreading	17
4.6.5.1 Definition	17

4.6.5.2	Limit.....	17
5	Testing for compliance with technical requirements.....	17
5.1	Conditions for testing.....	17
5.1.1	Environmental conditions for testing.....	17
5.1.2	Test sequences.....	18
5.1.2.1	General test transmission sequences.....	18
5.2	Interpretation of the measurement results.....	18
5.3	Essential radio test suites.....	19
5.3.1	Product information.....	19
5.3.2	Carrier frequencies.....	19
5.3.2.1	Test conditions.....	19
5.3.2.2	Test methods.....	19
5.3.2.2.1	Conducted measurement.....	19
5.3.2.2.2	Radiated measurement.....	20
5.3.3	RF output power, Transmit Power Control (TPC) and power density.....	20
5.3.3.1	Test conditions.....	20
5.3.3.2	Test method.....	20
5.3.3.2.1	Conducted measurement.....	20
5.3.3.2.2	Radiated measurement.....	22
5.3.4	Transmitter unwanted emissions outside the 5 GHz RLAN bands.....	23
5.3.4.1	Test conditions.....	23
5.3.4.2	Test method.....	23
5.3.4.2.1	Conducted measurement.....	23
5.3.4.2.2	Radiated measurement.....	24
5.3.5	Transmitter unwanted emissions within the 5 GHz RLAN bands.....	24
5.3.5.1	Test conditions.....	24
5.3.5.2	Test method.....	25
5.3.5.2.1	Conducted measurement.....	25
5.3.5.2.2	Radiated measurement.....	25
5.3.6	Receiver spurious emissions.....	25
5.3.6.1	Test conditions.....	25
5.3.6.2	Test method.....	26
5.3.6.2.1	Conducted measurement.....	26
5.3.6.2.2	Radiated measurement.....	26
5.3.7	Dynamic Frequency Selection (DFS).....	26
5.3.7.1	Test conditions.....	26
5.3.7.2	Test method.....	27
5.3.7.2.1	Conducted measurement.....	28
5.3.7.2.2	Radiated measurement.....	31
Annex A (normative):	The EN Requirements Table (EN-RT)	32
Annex B (normative):	Test sites and arrangements for radiated measurements.....	33
B.1	Test sites.....	33
B.1.1	Open air test sites.....	33
B.1.2	Anechoic chamber.....	34
B.1.2.1	General.....	34
B.1.2.2	Description.....	34
B.1.2.3	Influence of parasitic reflections.....	34
B.1.2.4	Calibration and mode of use.....	35
B.2	Test antenna.....	36
B.3	Substitution antenna.....	37
Annex C (normative):	General description of measurement	38
C.1	Conducted measurements.....	38
C.2	Radiated measurements.....	38
C.3	Substitution measurement.....	39

Annex D (normative):	DFS parameters	40
Annex E (informative):	The EN title in the official languages	41
Annex F (informative):	Bibliography.....	42
History		43

Intellectual Property Rights

IPRs essential or potentially essential to the present document may have been declared to ETSI. The information pertaining to these essential IPRs, if any, is publicly available for **ETSI members and non-members**, and can be found in ETSI SR 000 314: "*Intellectual Property Rights (IPRs); Essential, or potentially Essential, IPRs notified to ETSI in respect of ETSI standards*", which is available from the ETSI Secretariat. Latest updates are available on the ETSI Web server (<http://webapp.etsi.org/IPR/home.asp>).

Pursuant to the ETSI IPR Policy, no investigation, including IPR searches, has been carried out by ETSI. No guarantee can be given as to the existence of other IPRs not referenced in ETSI SR 000 314 (or the updates on the ETSI Web server) which are, or may be, or may become, essential to the present document.

Foreword

This Candidate Harmonized European Standard (Telecommunications series) has been produced by ETSI Project Broadband Radio Access Networks (BRAN).

The present document has been produced by ETSI in response to a mandate from the European Commission issued under Council Directive 98/34/EC (as amended) laying down a procedure for the provision of information in the field of technical standards and regulations.

The present document is intended to become a Harmonized Standard, the reference of which will be published in the Official Journal of the European Communities referencing the Directive 1999/5/EC [1] of the European Parliament and of the Council of 9 March 1999 on radio equipment and telecommunications terminal equipment and the mutual recognition of their conformity ("the R&TTE Directive").

National transposition dates	
Date of adoption of this EN:	1 August 2003
Date of latest announcement of this EN (doa):	30 November 2003
Date of latest publication of new National Standard or endorsement of this EN (dop/e):	31 May 2004
Date of withdrawal of any conflicting National Standard (dow):	31 May 2005

Introduction

The present document is part of a set of standards designed to fit in a modular structure to cover all radio and telecommunications terminal equipment under the R&TTE Directive [1]. Each standard is a module in the structure. The modular structure is shown in figure 1.

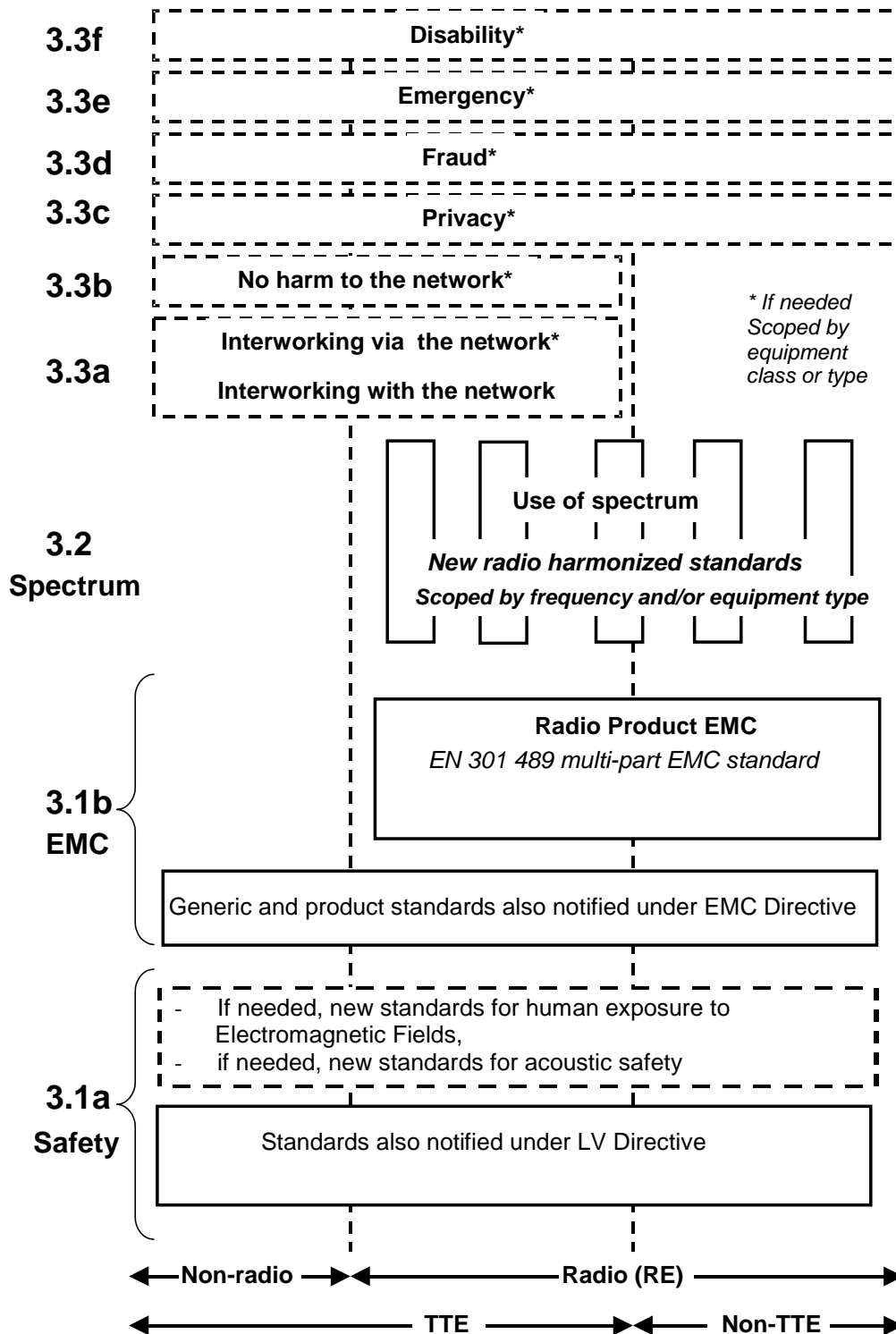

Figure 1: Modular structure for the various standards used under the R&TTE Directive [1]

The left hand edge of the figure 1 shows the different clauses of Article 3 of the R&TTE Directive [1].

For article 3.3 various horizontal boxes are shown. Dotted lines indicate that at the time of publication of the present document essential requirements in these areas have to be adopted by the Commission. If such essential requirements are adopted, and as far and as long as they are applicable, they will justify individual standards whose scope is likely to be specified by function or interface type.

The vertical boxes show the standards under article 3.2 for the use of the radio spectrum by radio equipment. The scopes of these standards are specified either by frequency (normally in the case where frequency bands are harmonized) or by radio equipment type.

For article 3.1b the diagram shows EN 301 489, the multi-part product EMC standard for radio used under the EMC Directive [2].

For article 3.1a the diagram shows the existing safety standards currently used under the LV Directive [3] and new standards covering human exposure to electromagnetic fields. New standards covering acoustic safety may also be required.

The bottom of the figure shows the relationship of the standards to radio equipment and telecommunications terminal equipment. A particular equipment may be radio equipment, telecommunications terminal equipment or both. A radio spectrum standard will apply if it is radio equipment. An article 3.3 standard will apply as well only if the relevant essential requirement under the R&TTE Directive [1] is adopted by the Commission and if the equipment in question is covered by the scope of the corresponding standard. Thus, depending on the nature of the equipment, the essential requirements under the R&TTE Directive [1] may be covered in a set of standards.

The modularity principle has been taken because:

- it minimizes the number of standards needed. Because equipment may, in fact, have multiple interfaces and functions it is not practicable to produce a single standard for each possible combination of functions that may occur in an equipment;
- it provides scope for standards to be added:
 - under article 3.2 when new frequency bands are agreed; or
 - under article 3.3 should the Commission take the necessary decisions without requiring alteration of standards that are already published;
- it clarifies, simplifies and promotes the usage of Harmonized Standards as the relevant means of conformity assessment.

1 Scope

The present document applies to 5 GHz high performance RLAN equipment that is intended to operate in the frequency bands 5 150 MHz to 5 350 MHz and 5 470 MHz to 5 725 MHz on any of the carrier frequencies as per table 1. Specific requirements are described for (equipment having the capability of) avoiding occupied channels by employing a Dynamic Frequency Selection mechanism and implementing Transmit Power Control, as required in ERC DEC(99)23.

NOTE: This mechanism is also required and described in ITU-R Recommendation M.1652.

Table 1: Nominal carrier frequency allocations

Carrier centre frequency f_c (MHz)
5 180
5 200
5 220
5 240
5 260
5 280
5 300
5 320
5 500
5 520
5 540
5 560
5 580
5 600
5 620
5 640
5 660
5 680
5 700

The present document is intended to cover the provisions of Directive 1999/5/EC [1] (R&TTE Directive) Article 3.2, which states that: "..... radio equipment shall be so constructed that it effectively uses the spectrum allocated to terrestrial/space radio communications and orbital resources so as to avoid harmful interference".

In addition to the present document, other ENs that specify technical requirements in respect of essential requirements under other parts of Article 3 of the R&TTE Directive [1] will apply to equipment within the scope of the present document.

NOTE: A list of such ENs is included on the web site <http://www.newapproach.org>.

2 References

The following documents contain provisions which, through reference in this text, constitute provisions of the present document.

- References are either specific (identified by date of publication and/or edition number or version number) or non-specific.
- For a specific reference, subsequent revisions do not apply.
- For a non-specific reference, the latest version applies.

Referenced documents which are not found to be publicly available in the expected location might be found at <http://docbox.etsi.org/Reference>.

- [1] Directive 1999/5/EC of the European Parliament and of the Council of 9 March 1999 on radio equipment and telecommunications terminal equipment and the mutual recognition of their conformity (R&TTE Directive).
- [2] Council Directive 89/336/EEC of 3 May 1989 on the approximation of the laws of the Member States relating to electromagnetic compatibility (EMC Directive).
- [3] Council Directive 73/23/EEC of 19 February 1973 on the harmonization of the laws of Member States relating to electrical equipment designed for use within certain voltage limits (LV Directive).
- [4] ETSI TR 100 028-1: "Electromagnetic compatibility and Radio spectrum Matters (ERM); Uncertainties in the measurement of mobile radio equipment characteristics; Part 1".
- [5] ETSI TR 100 028-2: "Electromagnetic compatibility and Radio spectrum Matters (ERM); Uncertainties in the measurement of mobile radio equipment characteristics; Part 2".
- [6] CISPR 16-1: "Specification for radio disturbance and immunity measuring apparatus and methods- Part 1: Radio disturbance and immunity measuring apparatus".

3 Definitions, symbols and abbreviations

3.1 Definitions

For the purposes of the present document, the terms and definitions given in the R&TTE Directive [1] and the following apply:

burst: period during which radio waves are intentionally transmitted, preceded and succeeded by periods during which no intentional transmission is made

channel: amount of spectrum used by a single RLAN device operating on one of the carrier frequencies listed in table 1 of EN 301 893

environmental profile: range of environmental conditions under which equipment within the scope of EN 301 893 is required to comply with the provisions of EN 301 893

in-service monitoring: mechanism to check a channel in use by the RLAN for the presence of a radar signal with a level above the Interference Detection Threshold

Master mode: operating mode in which the RLAN device has the capability to transmit without receiving an enabling signal

NOTE: In this mode it is able to select a channel and initiate a network by sending enabling signals to other RLAN devices. An RLAN network shall always have at least one RLAN device operating in Master mode. An RLAN device operating in Master mode shall use a Radar Interface Detection Function.

simulated radar burst: series of periodic radio wave pulses, separated by an interburst period during which no pulses are transmitted.

Slave mode: operating mode in which the transmissions of the RLAN are under control of the Master

NOTE: An RLAN device in Slave mode may use a Radar Interference Detection Function

Transmit Power Control (TPC): technique in which the transmitter output power is controlled resulting in reduced interference to other systems

5 GHz RLAN bands: frequency ranges: 5 150 MHz to 5 350 MHz and 5 470 MHz to 5 725 MHz.

3.2 Symbols

For the purposes of the present document, the following symbols apply:

A	Measured power output (dBm)
B	Radar burst period
Ch _f	Channel free from radars
Ch _r	Channel occupied by a radar
D	Measured power density
E	Field strength
E _o	Reference field strength
f _c	Carrier frequency
G	Antenna gain (dBi)
L	Radar burst length
n	Number of channels
P _H	Calculated EIRP at highest power level
P _L	Calculated EIRP at lowest power level
PD	Calculated power density
R	Distance
R _o	Reference distance
S ₀	Signal power
T ₀	Time instant
T ₁	Time instant
T ₂	Time instant
T ₃	Time instant
W	Radar pulse width
x	Observed duty cycle

3.3 Abbreviations

For the purposes of the present document, the following abbreviations apply:

DFS	Dynamic Frequency Selection
EIRP	Equivalent Isotropically Radiated Power
EMC	Electro-Magnetic Compatibility
ERP	Effective Radiated Power
LV	Low Voltage
PHY	Physical
ppm	parts per million
PRF	Pulse Repetition Frequency
R&TTE	Radio and Telecommunications Terminal Equipment
RE	Radio Equipment
TPC	Transmit Power Control
Tx	Transmit, Transmitter
UUT	Unit Under Test

4 Technical requirements specifications

4.1 Environmental profile

The technical requirements of the present document apply under the environmental profile for operation of the equipment, which shall be stated by the supplier. The equipment shall comply with all the appropriate technical requirements of the present document at all times when operating within the boundary limits of the stated operational environmental profile.

4.2 Carrier frequencies

4.2.1 Definition

The equipment is required to operate on the applicable specific carrier centre frequencies that correspond to the nominal carrier frequencies f_c defined in table 1.

4.2.2 Limits

The actual carrier centre frequency for any given channel given in table 1 shall be maintained within the range $f_c \pm 20$ ppm.

4.2.3 Conformance

Conformance tests as defined in clause 5.3.2 shall be carried out.

4.3 RF output power, Transmit Power Control (TPC) and power density

4.3.1 Definition

The RF output power is the mean equivalent isotropically radiated power during a transmission burst.

Transmit Power Control (TPC) is a mechanism to be used by the UUT to ensure a mitigation factor of at least 3 dB on the aggregate power from a large number of devices. This requires the UUT to have the capability to operate at least 6 dB below the values for mean EIRP given in table 2.

The power density is the mean equivalent isotropically radiated power density in dBm per MHz during a transmission burst.

4.3.2 Limits

4.3.2.1 RF output power and power density at the highest power level

The RF output power and the power density when configured to operate at the highest stated power level shall not exceed the levels given in table 2.

Table 2: Mean EIRP limits for RF output power and power density at the highest power level

Frequency range [MHz]	mean EIRP [dBm]	mean EIRP density limit [dBm/MHz]
5 150 to 5 350	23	11
5 470 to 5 725	30	18

4.3.2.2 RF output power at the lowest power level

The RF output power during a transmission burst when configured to operate at the lowest stated power level shall not exceed the levels given in table 3.

Table 3: Mean EIRP limits for RF output power at the lowest power level

Frequency range [MHz]	mean EIRP [dBm]
5 150 to 5 350	17
5 470 to 5 725	24

4.3.3 Conformance

Conformance tests as defined in clause 5.3.3 shall be carried out.

4.4 Transmitter unwanted emissions

4.4.1 Transmitter unwanted emissions outside the 5 GHz RLAN bands

4.4.1.1 Definition

These are radio frequency emissions outside the 5 GHz RLAN bands.

4.4.1.2 Limits

The level of unwanted emission shall not exceed the limits given in table 4.

Table 4: Transmitter unwanted emission limits outside the 5 GHz RLAN bands

Frequency range	Maximum power, ERP [dBm]	Bandwidth
30 MHz to 47 MHz	-36	100 kHz
47 MHz to 74 MHz	-54	100 kHz
74 MHz to 87,5 MHz	-36	100 kHz
87,5 MHz to 118 MHz	-54	100 kHz
118 MHz to 174 MHz	-36	100 kHz
174 MHz to 230 MHz	-54	100 kHz
230 MHz to 470 MHz	-36	100 kHz
470 MHz to 862 MHz	-54	100 kHz
862 MHz to 1 GHz	-36	100 kHz
1 GHz to 5,15 GHz	-30	1 MHz
5,35 GHz to 5,47 GHz	-30	1 MHz
5,725 GHz to 26,5 GHz	-30	1 MHz

4.4.1.3 Conformance

Conformance tests as defined in clause 5.3.4 shall be carried out.

4.4.2 Transmitter unwanted emissions within the 5 GHz RLAN bands

4.4.2.1 Definition

These are radio frequency emissions within the 5 GHz RLAN bands.

4.4.2.2 Limits

The average level of the transmitted spectrum within the 5 GHz RLAN bands shall not exceed the limits given in figure 2.

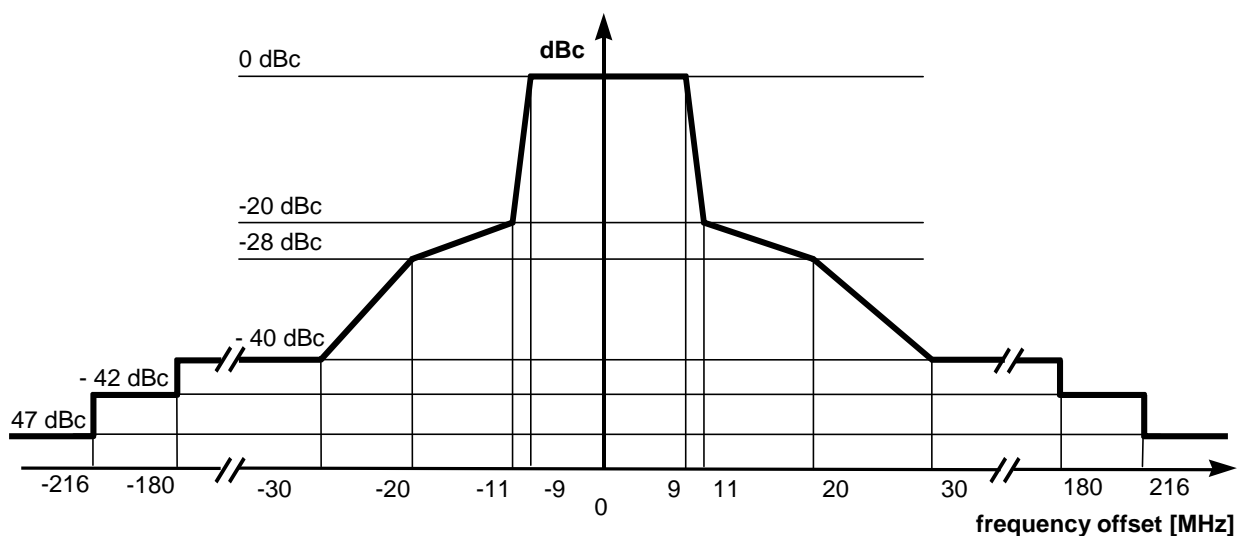

NOTE: dBc is the spectral density relative to the maximum spectral power density of the transmitted signal.

Figure 2: Transmit spectral power mask

4.4.2.3 Conformance

Conformance tests as defined in clause 5.3.5 shall be carried out.

4.5 Receiver spurious emissions

4.5.1 Definition

Receiver spurious emissions are defined as emissions of the active receiver.

4.5.2 Limits

The spurious emissions of the receiver shall not exceed the limits given in table 5.

Table 5: Spurious radiated emission limits

Frequency range	Maximum power, ERP	Measurement bandwidth
30 MHz to 1 GHz	-57 dBm	100 kHz
1 GHz to 26,5 GHz	-47 dBm	1 MHz

4.5.3 Conformance

Conformance tests as defined in clause 5.3.6 shall be carried out.

4.6 Dynamic Frequency Selection (DFS)

An RLAN shall employ a Dynamic Frequency Selection (DFS) function to:

- detect interference from other systems and to avoid co-channel operation with these systems, notably radar systems;
- provide on aggregate a uniform loading of the spectrum across all devices.

The DFS function as described in the present document is not tested for its ability to detect frequency agile radars.

Within the context of the operation of the DFS function, an RLAN device shall operate in either Master mode or Slave mode. RLAN devices operating in Slave mode (Slave device) can only operate in a network controlled by a RLAN device operating in Master mode (Master device).

The operational behaviour and individual DFS requirements that are associated with these modes are as follows:

Master devices:

- a) the Master device shall use a Radar Interference Detection function in order to detect radar signals with a level above the *Interference Detection threshold* in the frequency ranges 5 250 to 5 350 MHz and 5 470 to 5 725 MHz. Radar detection is not required in the frequency range 5 150 to 5 250 MHz.;
- b) the Master device initiates an RLAN network by transmitting control signals that will enable other RLAN devices, to associate (participate in a wireless network) with the Master device;
- c) before initiating a network on a channel, the Master shall perform a *Channel Availability Check* for a certain duration (*Channel Availability Check Time*) to ensure that there is no radar operating on the channel, using the Radar Interference Detection function described under a);
- d) during normal operation, the Master shall monitor the operating channel (*In-Service Monitoring*) to ensure that there is no radar operating on the channel, using the Radar Interference Detection function described under a);
- e) if the Master device has detected a radar signal, during In-Service Monitoring as described under d), the operating channel of the RLAN is made unavailable. The Master shall instruct all associated devices to stop transmitting on this channel, which they shall do within the *Channel Move Time*. The Aggregate Transmissions during the *Channel Move Time* should be limited to the *Channel Closing Transmission Time*;
- f) the Master shall not resume any transmissions on this channel during a period of 30 minutes after a radar signal was detected, using the Radar Interference Detection function described under a). This period is referred as the *Non-Occupancy Period* in figure 9.

Slave devices:

- g) a Slave device shall not transmit before having received an appropriate enabling signal from a Master device;
- h) a Slave device shall stop all its transmissions whenever instructed by a Master device to which it is associated. The device shall not resume any transmissions until it has again received enabling signals from a Master device;
- i) a Slave device which is required to perform radar detection (see table D.3), shall stop its own transmissions if it has detected a radar.

The Master device may implement the Radar Interference Detection function referred to under a) using another device associated with the Master. In such a case, the combination should be tested against the requirements applicable to the Master.

See tables 6 and 7 for the applicability of DFS requirements prior to use a channel (*Channel Availability Check*) and during normal operation (*In-Service Monitoring*) for each of the above mentioned operational modes.

The manufacturer shall state whether the UUT is capable of operating as a Master and/or as a Slave. In the case the UUT is a Slave the maximum power level of the UUT will define whether or not the UUT needs to have Radar Interference Detection Function. If the UUT is capable of operating in more than one operating mode then each operating mode shall be tested separately.

Table 6: Applicability of DFS requirements prior to use a channel

Requirement	Operational Mode		
	Master	Slave (without radar detection)	Slave (with radar detection)
Interference Detection Threshold	✓	Not required	Not required
Channel Availability Check Time	✓	Not required	Not required
Uniform Spreading	✓	Not required	Not required

Table 7: Applicability of DFS requirements during normal operation

Requirement	Operational Mode		
	Master	Slave (without radar detection)	Slave (with radar detection)
Interference Detection Threshold	✓	Not required	✓
Channel Closing Transmission Time	✓	✓	✓
Channel Move Time	✓	✓	✓

4.6.1 Interference Detection Threshold

4.6.1.1 Definition

The Interference Detection Threshold is the level to be used by the DFS mechanism to detect radar interference.

4.6.1.2 Limit

In the case of a Master the Interference Detection Threshold shall not exceed the value defined in table D.2. In the case of a Slave with radar detection the Interference Detection Threshold shall not exceed the value defined in table D.3.

4.6.1.3 Conformance

Conformance tests for this requirement are defined in clause 5.3.7.

4.6.2 Channel Availability Check Time

4.6.2.1 Definition

The Channel Availability Check Time is defined as the time during which a channel shall be checked for the presence of a radar signal (table D.4) with a level above the Interference Detection Threshold (table D.2). No transmissions shall occur during this time.

This channel availability check shall be performed by the Master device after it is powered on and before it can initiate a network on a channel, or in the event that the network has to move to a new channel and no information is available about the presence of radar transmissions on that channel.

4.6.2.2 Limit

The Channel Availability Check Time shall not be less than the value defined in table D.1.

4.6.2.3 Conformance

Conformance tests for this requirement are defined in clause 5.3.7.

4.6.3 Channel Closing Transmission Time

4.6.3.1 Definition

The Channel Closing Transmission Time is defined as the aggregate duration of transmissions of the RLAN device during the Channel Move Time which starts upon detection of an interfering signal above the Interference Detection Threshold. The aggregate duration of all transmissions shall not include quiet periods in between transmissions.

4.6.3.2 Limit

The Channel Closing Transmission Time shall not exceed the limit defined in table D.1.

4.6.3.3 Conformance

Conformance tests for this requirement are defined in clause 5.3.7.

4.6.4 Channel Move Time

4.6.4.1 Definition

The Channel Move Time is defined as the time taken by an RLAN device to cease all transmissions on the channel upon detection of an interfering signal above the Interference Detection Threshold.

4.6.4.2 Limit

The Channel Move Time shall not exceed the limit defined in table D.1.

4.6.4.3 Conformance

Conformance tests for this requirement are defined in clause 5.3.7.

4.6.5 Uniform Spreading

4.6.5.1 Definition

The intention of the uniform spreading is to provide, on aggregate, a uniform loading of the spectrum across all devices. This requires that the UUT, when operating on an individual basis, shall select an operating channel out of a minimum of 14 channels from those listed in table 1 so that the probability of selecting a given channel shall be the same for all channels. Devices using only the band 5 470 to 5 725 MHz shall select an operating channel out of the 11 channels listed in table 1 for this band so that the probability of selecting a given channel shall be the same for all channels.

In countries where the whole frequency range defined in clause 3.1 may not be available, the number of required channels for the spreading shall be adjusted accordingly.

When operating as part of a network of devices, that includes more than one device operating in Master mode, the selection of the operating channel may be under control of the network.

4.6.5.2 Limit

The probability of selecting each channel shall be within 10 % of the theoretical probability. For "n" channels, the theoretical probability is 1/n.

5 Testing for compliance with technical requirements

5.1 Conditions for testing

5.1.1 Environmental conditions for testing

Tests defined in the present document shall be carried out at representative points within the boundary limits of the stated operational environmental profile.

Where technical performance varies subject to environmental conditions, tests shall be carried out under a sufficient variety of environmental conditions (within the boundary limits of the stated operational environmental profile) to give confidence of compliance for the affected technical requirements.

5.1.2 Test sequences

5.1.2.1 General test transmission sequences

Unless mentioned otherwise, all the tests in the present document shall be performed by using a test transmission sequence that shall consist of regularly transmitted bursts with transmission interval of e.g. 2 ms. The bursts shall be fixed in length in a sequence and shall exceed the transmitter minimum activity ratio of 10 %. The minimum duration of the sequence shall be adequate for the test purposes. The test sequence shall be stated in the test report. General structure of the test sequence is shown in figure 3.

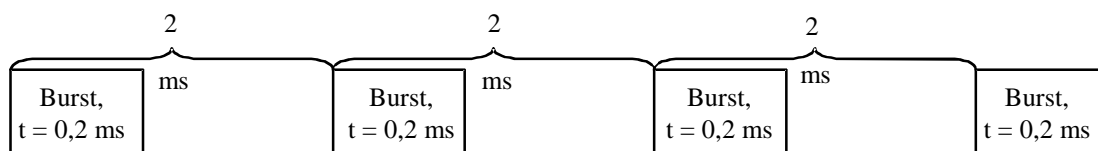

Figure 3: General structure of the test transmission sequences

5.2 Interpretation of the measurement results

The interpretation of the results recorded in a test report for the measurements described in the present document shall be as follows:

- the measured value related to the corresponding limit will be used to decide whether an equipment meets the requirements of the present document;
- the value of the measurement uncertainty for the measurement of each parameter shall be included in the test report;
- the recorded value of the measurement uncertainty shall be, for each measurement, equal to or lower than the figures in table 8;
- the shared risk approach shall be applied for the interpreting of all measurement results.

For the test methods, according to the present document, the measurement uncertainty figures shall be calculated in accordance with TR 100 028-1 [4] and TR 100 028-2 [5] and shall correspond to an expansion factor (coverage factor) $k = 1,96$ or $k = 2$ (which provide confidence levels of respectively 95 % and 95,45 % in the case where the distributions characterizing the actual measurement uncertainties are normal (Gaussian)).

Table 8 is based on such expansion factors.

Table 8: Maximum measurement uncertainty

Parameter	Uncertainty
RF frequency	$\pm 1 \times 10^{-5}$
RF power conducted	$\pm 1,5$ dB
RF power radiated	± 6 dB
Spurious emissions, conducted	± 3 dB
Spurious emissions, radiated	± 6 dB
Humidity	± 1 °C
Temperature	± 5 %
Time	± 5 %

5.3 Essential radio test suites

5.3.1 Product information

The following information shall be stated by the manufacturer in order to carry out the test suites:

- the operating frequency range(s) of the equipment;
- the operating modes (Master and/or Slave);
- the highest and the lowest possible power level (EIRP) of the equipment;
- the intended antenna assemblies and their corresponding gains;
- the operational environmental profile applicable to the equipment;
- the test sequence used.

5.3.2 Carrier frequencies

5.3.2.1 Test conditions

The UUT shall be set to operate at a normal RF power output level.

For a UUT with antenna connector(s) and using external antenna(s), or for a UUT with integral antenna(s) but with a temporary antenna connector provided, conducted measurements shall be used.

For a UUT with integral antenna(s) and without a temporary antenna connector, radiated measurements shall be used.

5.3.2.2 Test methods

5.3.2.2.1 Conducted measurement

Equipment operating without modulation

This test method requires that the UUT can be operated in an unmodulated test mode.

The UUT shall be connected to a frequency counter and operated in an unmodulated mode. The result shall be recorded.

Equipment operating with modulation

This method is an alternative to the above method in case the UUT can not be operated in an un-modulated mode.

The UUT shall be connected to spectrum analyser.

The settings of the spectrum analyser shall be adjusted to optimize the instruments frequency accuracy.

Max Hold shall be selected and the centre frequency adjusted to that of the UUT.

The peak value of the power envelope shall be measured and noted. The span shall be reduced and the marker moved in a positive frequency increment until the upper, (relative to the centre frequency), -10 dBc point is reached. This value shall be noted as f1.

The marker shall then be moved in a negative frequency increment until the lower, (relative to the centre frequency), -10 dBc point is reached. This value shall be noted as f2.

The centre frequency is calculated as $(f1 + f2)/2$.

5.3.2.2.2 Radiated measurement

The test set up as described in annex B shall be used with a spectrum analyser of sufficient accuracy attached to the test antenna (see clause 5.2).

The test procedure is as described under clause 5.3.2.2.1.

5.3.3 RF output power, Transmit Power Control (TPC) and power density

5.3.3.1 Test conditions

The conformance requirements in clause 4.3 shall be verified at the lowest, the middle and the highest carrier centre frequency (see table 1) of the stated frequency range(s). The measurements shall be performed using normal operation of the equipment with test signal applied (see clause 5.1.2.1).

NOTE: Special test functions may be needed in the UUT to make this test possible.

For a UUT with antenna connector(s) and using external antenna(s), or for a UUT with integral antenna(s) but with a temporary antenna connector provided, conducted measurements shall be used in conjunction with the stated antenna assembly gain(s).

For a UUT with integral antenna(s) and without a temporary antenna connector, radiated measurements shall be used.

5.3.3.2 Test method

5.3.3.2.1 Conducted measurement

5.3.3.2.1.1 RF output power at the highest power level

The UUT shall be configured to operate at the highest stated power level.

Step 1:

- a) using suitable attenuators, the output power of the transmitter shall be coupled to a matched diode detector. The output of the diode detector shall be connected to the vertical channel of an oscilloscope;
- b) the combination of the diode detector and the oscilloscope shall be capable of faithfully reproducing the duty cycle of the transmitter output signal;
- c) the observed duty cycle of the transmitter ($T_x \text{ on} / (T_x \text{ on} + T_x \text{ off})$) shall be noted as x ($0 < x \leq 1$), and recorded in the test report. For the purpose of testing, the equipment shall be operated with a duty cycle that is equal to or greater than 0,1 (see clause 5.1.2).

Step 2:

- a) the RF output power of the transmitter when operating at the highest power level shall be determined using a wideband calibrated RF power meter with a matched thermocouple detector or an equivalent thereof and with an integration period that exceeds the repetition period of the transmitter by a factor 5 or more. The observed value shall be noted as "A" (in dBm);
- b) the EIRP shall be calculated from the above measured power output A (in dBm) the observed duty cycle x , and the stated antenna gain "G" in dBi, according to the formula in c). If more than one antenna assembly is intended, the gain of the antenna assembly with the highest gain shall be used.
- c) $P_H = A + G + 10 \log (1/x)$ (dBm).
- d) P_H shall be recorded in the test report.

5.3.3.2.1.2 RF output power at the lowest power level

The UUT shall be configured to operate at the lowest stated power level.

Step 1:

- a) using suitable attenuators, the output power of the transmitter shall be coupled to a diode detector. The output of the diode detector shall be connected to the vertical channel of an oscilloscope;
- b) the combination of the diode detector and the oscilloscope shall be capable of faithfully reproducing the duty cycle of the transmitter output signal;
- c) the observed duty cycle of the transmitter (Tx on/(Tx on + Tx off)) shall be noted as x ($0 < x \leq 1$), and recorded in the test report. For the purpose of testing, the equipment shall be operated with a duty cycle that is equal to or greater than 0,1 (see clause 5.1.2).

Step 2:

- a) the RF output power of the transmitter when operating at the lowest power level shall be determined using a wideband calibrated RF power meter with a thermocouple detector or an equivalent thereof and with an integration period that exceeds the repetition period of the transmitter by a factor 5 or more. The observed value shall be noted as "A" (in dBm);
- b) the EIRP shall be calculated from the above measured power output A (in dBm) the observed duty cycle x , and the stated antenna gain "G" in dBi, according to the formula in c). If more than one antenna assembly is intended, the gain of the antenna assembly with the highest gain shall be used.
- c) $P_L = A + G + 10 \log(1/x)$ (dBm).
- d) P_L shall be recorded in the test report.

5.3.3.2.1.3 Power density

The UUT shall be operated as described in clause 5.3.3.2.1.1. Furthermore, for the purpose of this test, the minimum transmitter on-time should be 10 μ s.

In the case of radiated measurements, using a test site as described in annex B and applicable measurement procedures as described in annex C, the power density as defined in clause 4.3.1 shall be measured and recorded.

In case of conducted measurements, the transmitter shall be connected to the measuring equipment via a suitable attenuator and the power density as defined in clause 4.3.1 shall be measured and recorded.

The power density shall be determined using a spectrum analyser of adequate bandwidth in combination with an RF power meter.

Connect an RF power meter to the narrow IF output of the spectrum analyser and correct its reading using a known reference source, e.g. a signal generator.

NOTE: The IF output of the spectrum analyser may be 20 dB or more below the input level of the spectrum analyser. Unless the power meter has adequate sensitivity, a wideband amplifier may be required.

The test procedure shall be as follows:

Step 1:

- the measurement set-up shall be calibrated with a CW signal from a calibrated source; the reference signal should have a strength of 10 dBm;
- the settings of the spectrum analyser shall be:
 - centre Frequency: equal to the signal source;
 - resolution BW: 1 MHz;
 - video BW: same;

- detector mode: positive peak;
- averaging: off;
- span: zero Hz;
- amplitude: adjust for middle of the instrument's range.

Step 2:

- the calibrating signal power shall be reduced to 0 dBm and it shall be verified that the power meter reading also reduces by 10 dB.

Step 3:

- connect the UUT. Using the following settings of the spectrum analyser in combination with "max hold" function, find the frequency of highest power output in the power envelope:
 - centre Frequency: equal to operating frequency;
 - resolution BW: 1 MHz;
 - video BW: same;
 - detector mode: positive peak;
 - averaging: off;
 - Span: 3 times the spectrum width;
 - amplitude: adjust for middle of the instrument's range.
- the frequency found shall be recorded.

Step 4:

- set the centre frequency of the spectrum analyser to the found frequency and switch to zero span. The power meter indicates the measured power density (D). The mean power density EIRP is calculated from the above measured power density (D), the observed duty cycle x (see clause 5.3.3.2.1.2 step 1), and the applicable antenna assembly gain "G" in dBi, according to the formula below. If more than one antenna assembly is intended, the gain of the antenna assembly with the highest gain shall be used:
 - $PD = D + G + 10 \log (1/x)$;
 - PD shall be recorded in the test report.

The above procedure shall be repeated for each of the three frequencies identified by the procedure given in clause 5.3.3.1.

Where the spectrum analyser bandwidth is non-Gaussian, a suitable correction factor shall be determined and applied.

Where a spectrum analyser is equipped with a facility to measure power density, this facility may be used instead of the above procedure.

5.3.3.2.2 Radiated measurement

The test set up as described in annexes B and C shall be used with a RF power meter of sufficient accuracy attached to the test antenna (see clause 5.2).

The test procedure is as described under clause 5.3.3.2.1.

5.3.4 Transmitter unwanted emissions outside the 5 GHz RLAN bands

5.3.4.1 Test conditions

The conformance requirements in clause 4.4.1 shall be verified under normal operating conditions, and at the lowest, the middle, and the highest carrier centre frequency (see table 1) of the stated frequency range(s). The UUT shall be configured to operate at the highest stated power level.

For UUT without an integral antenna and for a UUT with an integral antenna but with a temporary antenna connector, one of the following options shall be used:

- the level of unwanted emissions shall be measured as their power in a specified load (conducted spurious emissions) and their effective radiated power when radiated by the cabinet or structure of the equipment with the antenna connector terminated by a specified load (cabinet radiation); or
- the level of unwanted emissions shall be measured as their effective radiated power when radiated by cabinet and antenna.

In the case where the UUT has an integral antenna, but no temporary antenna connector, only radiated measurements shall be used.

5.3.4.2 Test method

5.3.4.2.1 Conducted measurement

The UUT shall be connected to a spectrum analyser capable of RF power measurements. The test procedure shall be as follows:

- a) the settings of the spectrum analyser shall be as follows:
 - sensitivity: at least 6 dB below the limit given in table 4;
 - video bandwidth: 1 MHz;
 - video averaging on, or peak hold.

The video signal of the spectrum analyser shall be "gated" such that the spectrum measured shall be measured between 4,0 μ s before the start of the burst to 4,0 μ s after the end of the burst.

NOTE: The "start of the burst" is the centre of the first sample of the preamble heading the burst. The "end of the burst" is the centre of the last sample in the burst.

This gating may be analogue or numerical, dependent upon the design of the spectrum analyser:

- b) initially the power level shall be measured in the ranges:
 - 47 MHz to 74 MHz;
 - 87,5 MHz to 118 MHz;
 - 174 MHz to 230 MHz;
 - 470 MHz to 862 MHz;

with a resolution bandwidth of 1 MHz and in a frequency scan mode.

- c) if any measurement is greater than -54 dBm then measurements shall be taken with a resolution bandwidth of 100 kHz, zero frequency scan, at the 11 frequencies spaced 100 kHz apart in a band $\pm 0,5$ MHz centred on the failing frequency;

EXAMPLE 1: A UUT fails at 495 MHz. Measurements are made in a 100 kHz bandwidth on 494,5 MHz, 494,6 MHz, 494,7 MHz. etc. up to 495,5 MHz.

- d) initially the power level shall be measured in the ranges
- 25 MHz to 47 MHz;
 - 74 MHz to 87,5 MHz;
 - 118 MHz to 174 MHz;
 - 230 MHz to 470 MHz;
 - 862 MHz to 1 GHz;

with a resolution bandwidth of 1 MHz and in a frequency scan mode.

- e) if any measurement in d) is greater than -36 dBm, then measurements shall be taken with a resolution bandwidth of 100 kHz, zero frequency scan, at the 11 frequencies spaced 100 kHz apart in a band $\pm 0,5$ MHz centred on the failing frequency;

EXAMPLE 2: A UUT fails at 285 MHz. Measurements are made in a 100 kHz bandwidth on 284,5 MHz, 284,6 MHz, 284,7 MHz. etc. up to 285,5 MHz.

- f) the power level shall be measured in the ranges
- 1 GHz to 5,15 GHz;
 - 5,725 GHz to 26,5 GHz;

with a resolution bandwidth of 1 MHz and in a frequency scan mode.

- g) the power level shall be measured in the range:
- 5,35 GHz to 5,47 GHz;

with a resolution bandwidth of 1 MHz with zero frequency scan.

5.3.4.2.2 Radiated measurement

The test set up as described in annex B shall be used with a spectrum analyser of sufficient accuracy attached to the test antenna (see clause 5.2).

The test procedure is as described under 5.3.4.2.1.

5.3.5 Transmitter unwanted emissions within the 5 GHz RLAN bands

5.3.5.1 Test conditions

The conformance requirements in clause 4.4.2 shall be verified under normal operating conditions, and at the lowest, the middle, and the highest carrier centre frequency (see table 1) of the stated frequency range(s). The UUT shall be configured to operate at the highest stated power level.

For UUT without an integral antenna and for a UUT with an integral antenna but with a temporary antenna connector, one of the following options shall be used:

- the level of unwanted emissions shall be calculated from their measured power in a specified load (conducted spurious emissions) in conjunction with the stated antenna assembly gain (if more than one antenna assembly is intended, the gain of the antenna assembly with the highest gain shall be used) and their effective radiated power when radiated by the cabinet or structure of the equipment with the antenna connector terminated by a specified load (cabinet radiation); or
- the level of unwanted emissions shall be measured as their effective radiated power when radiated by cabinet and antenna.

In the case where the UUT has an integral antenna, but no temporary antenna connector, only radiated measurements shall be used.

5.3.5.2 Test method

5.3.5.2.1 Conducted measurement

The settings of the spectrum analyser shall be as follows:

- resolution bandwidth: 1 MHz;
- video bandwidth: 30 kHz;
- video averaging on.

The video signal of the spectrum analyser shall be "gated" such that the spectrum measured shall be measured between 4,0 μ s before the start of the burst to 4,0 μ s after the end of the burst.

NOTE: The "start of the burst" is the centre of the first sample of the preamble heading the burst. The "end of the burst" is the centre of the last sample in the burst.

This gating may be analogue or numerical, dependent upon the design of the spectrum analyser.

Determination of the reference average power level

The spectrum analyser shall be tuned to measurement frequencies at every 1 MHz interval within $f_c - 9$ MHz to $f_c + 9$ MHz, with zero frequency scan. The maximum average power within $f_c - 9$ MHz to $f_c + 9$ MHz (except f_c) is the reference level for relative power measurements on the channel centred at f_c and shall be recorded to compute relative power levels as described below.

Determination of the relative average power levels

The power level shall be measured in the ranges:

- 5150 MHz to 5350 MHz;
- 5470 MHz to 5725 MHz;

excluding the interval $f_c - 9$ MHz to $f_c + 9$ MHz with a resolution bandwidth of 1 MHz and in a frequency scan mode. The average value of power relative to the reference average power level for the channel shall be noted.

5.3.5.2.2 Radiated measurement

The test set up as described in annex B shall be used with a spectrum analyser of sufficient accuracy attached to the test antenna (see clause 5.2).

The test procedure is as described under 5.3.5.2.1.

5.3.6 Receiver spurious emissions

5.3.6.1 Test conditions

The conformance requirements in clause 4.5 shall be verified under normal operating conditions, and at the lowest, the middle, and the highest carrier centre frequency (see table 1) of the stated frequency range(s).

For UUT without an integral antenna and for a UUT with an integral antenna but with a temporary antenna connector, one of the following options shall be used:

- the level of unwanted emissions shall be measured as their power in a specified load (conducted spurious emissions) and their effective radiated power when radiated by the cabinet or structure of the equipment with the antenna connector terminated by a specified load (cabinet radiation); or
- the level of unwanted emissions shall be measured as their effective radiated power when radiated by cabinet and antenna.

In the case where the UUT has an integral antenna, but no temporary antenna connector, only radiated measurements shall be used.

Test sequence (see clause 5.1.2.1) shall be applied to the receiver input at the reference sensitivity level according to the nominal bit rate.

5.3.6.2 Test method

5.3.6.2.1 Conducted measurement

Using a directional coupler, circulator or gating to remove the test data transmissions (and/or other means to isolate the emissions measurements instrument from the test data signals transmitted) the radio emissions from the UUT shall be measured while the UUT receives test data.

The settings of the spectrum analyser shall be as follows:

- frequency scan allowed;
- resolution bandwidth: 1 MHz or 100 kHz;
- video bandwidth: 1 MHz;
- video averaging on, or peak hold.

Tuning the spectrum analyser centre frequency over the measurement frequency bands specified in table 5, the power level of UUT receiver emissions shall be measured during test data transmissions. If gating is used to remove the unwanted energy from the test data transmissions, the tuning of the spectrum analyser shall not change during the gated-out time interval.

5.3.6.2.2 Radiated measurement

The test set up as described in annex B shall be used with a spectrum analyser of sufficient accuracy attached to the test antenna (see clause 5.2).

The test procedure is as described under 5.3.6.2.1.

5.3.7 Dynamic Frequency Selection (DFS)

5.3.7.1 Test conditions

The conformance requirements in clause 4.6 shall be verified under normal operating conditions and in each of the stated frequency range(s), and with each of the applicable radar signals defined in table D4.

For a UUT with antenna connector(s) and using external antenna(s), or for a UUT with integral antenna(s) but with a temporary antenna connector provided, conducted measurements shall be used. In this case, and if the UUT has a Radar Interference Detection Function, the output power of the signal generator producing the radar test signals defined in table D.4, shall provide a received signal power at the antenna connector of the UUT with a level equal to (*Interference Detection Threshold* + G), see tables D.2 and D.3. Parameter G [dBi] corresponds to the gain of the antenna assembly stated by the manufacturer. If more than one antenna assembly is intended, the gain of the antenna assembly with the lowest gain shall be used.

For a UUT with integral antenna(s) and without temporary antenna connector, radiated measurements shall be used. In this case, and if the UUT has a Radar Interference Detection Function, the output power of the signal generator shall provide a signal power at the antenna with a level equal to *Interference Detection Threshold* (table D.2, table D.3).

Some of the tests may require that the channel selection mechanism for the uniform spreading requirement will be disabled.

It should be noted that once a UUT is powered on, it will not start its normal operating functions immediately, as it will have to finish its power-up cycle first ($T_{\text{power_up}}$). As such, the UUT, as well as any other device used in the set-up, may be equipped with a feature that will indicate its status during the testing, e.g. power-up mode, normal operation mode, channel check status, radar detection event, etc.

5.3.7.2 Test method

When the UUT is an RLAN device operating as a Master, the test set-up, further referred to as "*Set-up A*", consists of a signal generator connected to the UUT and an RLAN device operating as a Slave. The latter is assumed to associate with the UUT (Master).

Figure 4 shows an example for "*Set-up A*". The set-up used shall be documented in the test report.

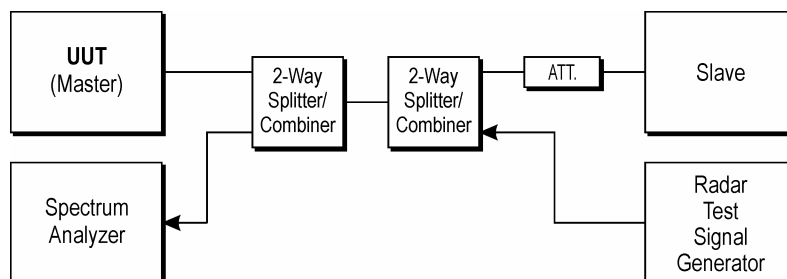

Figure 4: Set-up where UUT is a Master and radar test signals are injected into the Master

When the UUT is an RLAN device operating as a Slave without Radar Interference Detection Function, the test set-up, further referred to as "*Set-up B*", consists of a signal generator connected to a RLAN device operating as a Master and the UUT. The latter is assumed to associate with the Master.

Figure 5 shows an example for "*Set-up B*". The set-up used shall be documented in the test report.

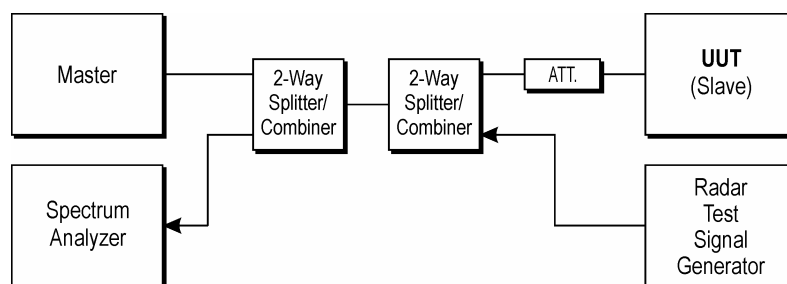

Figure 5: Set-up where UUT is a Slave and radar test signals are injected into the Master

When the UUT is an RLAN device operating as a Slave with Radar Interference Detection Function, the test set-up consists of a signal generator, the UUT and a RLAN device operating as a Master. The UUT (Slave) is assumed to associate with the Master. The tests need to be performed when the generator is connected to the Master using "*Set-up B*" described above. Additionally, the tests need to be repeated using a set-up, further referred to as "*Set-up C*", by which the signal generator is connected to the UUT (Slave).

Figure 6 shows an example for "*Set-up C*". The set-up used shall be documented in the test report.

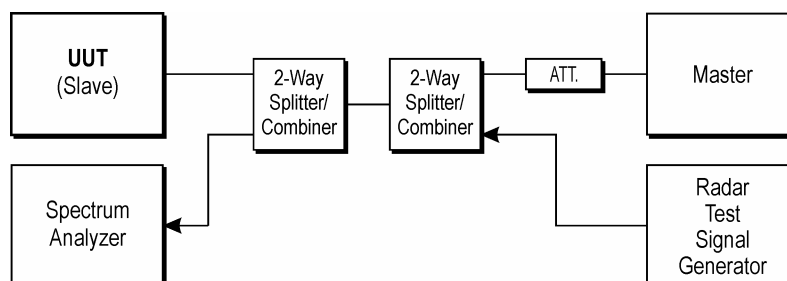

Figure 6: Set-up where UUT is a Slave and radar test signals are injected into the Slave

For the purposes of the test, the UUT as well as other RLAN devices used in the set-up may be equipped with a specific user interface to allow monitoring of the behaviour of the different devices of the set-up during the tests.

The UUT is capable of transmitting a test transmission sequence. The signal generator is capable of generating any of the radar test signals defined in table D.4.

Adequate measurement equipment, e.g. spectrum analyser, shall be used to measure the aggregate transmission time of the UUT.

5.3.7.2.1 Conducted measurement

This method shall be used for equipment with an antenna connector or for integral antenna equipment that have a temporary antenna connector provided.

One channel, outside the 5 150 to 5 250 MHz range, is selected from the stated operating frequency range(s). This channel is designated as Ch_r (channel occupied by a radar).

The UUT shall be configured to select Ch_r as the first operating channel.

$T_{ch_avail_check}$ is the minimum Channel Availability Check Time as specified in table D.1.

5.3.7.2.1.1 Interference Detection Threshold (during the Channel Availability Check) and Channel Availability Check Time

The test method described below applies to an RLAN device operating as a Master.

This test defines how the following DFS parameters can be verified:

- Interference Detection Threshold (during the Channel Availability Check);
- Channel Availability Check Time.

The different steps below define the procedure to verify the above-mentioned parameters when a radar burst is generated on the selected channel at the beginning or at the end of the Channel Availability Check Time.

5.3.7.2.1.1.1 Tests with radar burst at the beginning of the Channel Availability Check Time

The steps below define the procedure to verify successful radar detection on the selected channel during a period equal to the Channel Availability Check Time and avoidance of operation on that channel when a radar burst with a level equal to the Interference Detection Threshold occurs at the beginning of the Channel Availability Check Time.

- a) the signal generator and UUT are connected using the set-up referred to in clause 5.3.7.2 and the power of the UUT is switched off;
- b) the UUT is powered on at T_0 . T_1 denotes the instant when the UUT has completed its power-up sequence (T_{power_up}). The channel availability check is expected to commence on Ch_r at instant T_1 and is expected to end no sooner than $T_1 + T_{ch_avail_check}$ unless a radar is detected sooner;
- c) radar bursts are generated on Ch_r using one of the test patterns defined in table D.4 at a level defined in clause 5.3.7.1. Radar bursts should commence at time T_1 and should continue for approximately 6 seconds;
- d) visual indication on the UUT of successful detection of the radar burst (if indication is available) should be recorded. Observation of Ch_r shall continue until the UUT starts transmitting on another channel. *(In the example given below, the UUT performs a channel availability check on a new channel after it has detected a radar on Ch_r).* It shall be verified and recorded that during the above steps no transmissions occurred on Ch_r ;
- e) a timing trace or description of the observed timing and behaviour of the UUT should be reported.

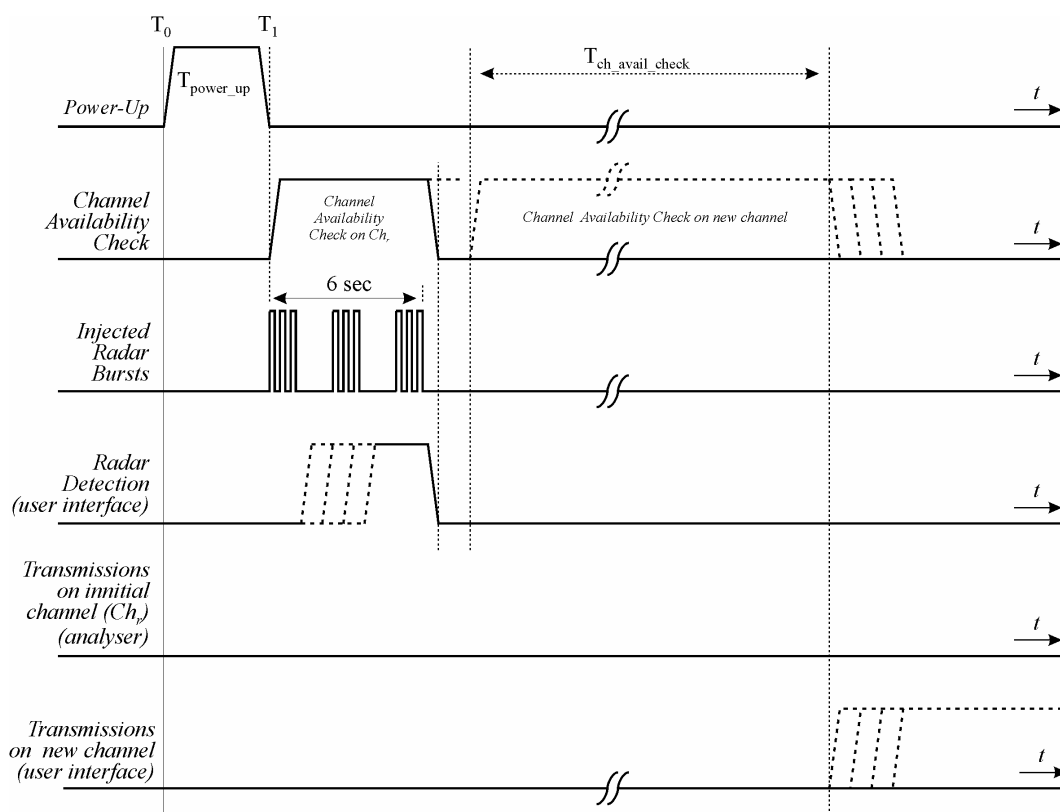

Figure 7: Example of timing for radar testing at the beginning of the Channel Availability Check Time

5.3.7.2.1.1.2 Tests with radar burst at the end of the Channel Availability Check Time

The steps below define the procedure to verify successful radar detection on the selected channel during a period equal to the Channel Availability Check Time and avoidance of operation on that channel when a radar burst with a level equal to the Interference Detection Threshold occurs at the end of the Channel Availability Check Time:

- f) the signal generator and UUT are connected using the set-up referred to in clause 5.3.7.2 and the power of the UUT is switched off;
- g) the UUT is powered up at T_0 . T_1 denotes the instant when the UUT has completed its power-up sequence ($T_{\text{power_up}}$). The channel availability check is expected to commence on Ch_i at instant T_1 and is expected to end no sooner than $T_1 + T_{\text{ch_avail_check}}$ unless a radar is detected sooner;
- h) radar bursts are generated on Ch_i using one of the test patterns defined in table D.4 at a level defined in clause 5.3.7.1. Radar bursts should commence near the end of the minimum required Channel Availability Check Time at time $T_1 + T_{\text{ch_avail_check}} - 6$ [sec] and should continue for the duration of this test;
- i) visual indication on the UUT of successful detection of the radar burst (if indication is available) should be recorded. Observation of Ch_i shall continue until the UUT starts transmitting on another channel. (In the example given below, the UUT performs a channel availability check on a new channel after it has detected a radar on Ch_i). It shall be verified and recorded that during the above steps no transmissions occurred on Ch_i ;
- j) a timing trace or description of the observed timing and behaviour of the UUT should be reported.

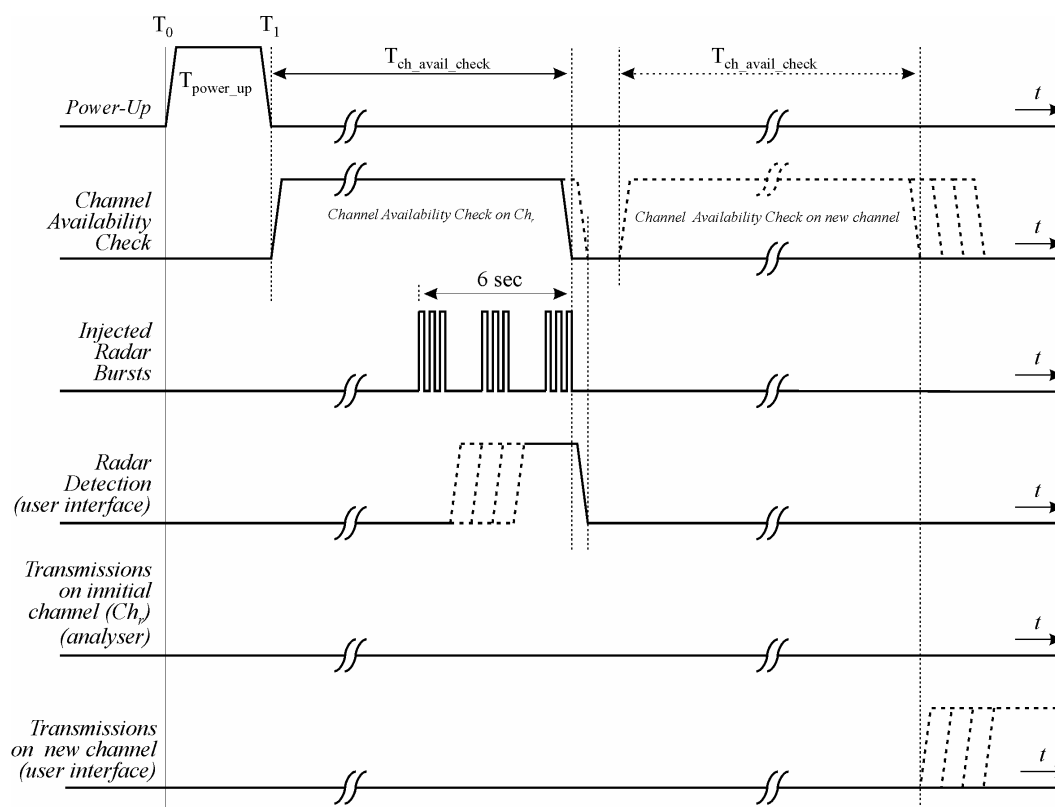

Figure 8: Example of timing for radar testing towards the end of the Channel Availability Check Time

5.3.7.2.1.2 Interference Detection Threshold (during In-Service Monitoring), Channel Closing Transmission Time, Channel Move Time and Non-Occupancy period

The test method described below is applicable to:

- RLAN devices operating as a Master;
- RLAN devices operating as a Slave device with a Radar Interference Detection Function;
- RLAN devices operating as a Slave device without a Radar Interference Detection Function.

These tests define how the following DFS parameters can be verified:

- Interference Detection Threshold (during In-Service Monitoring);
- Channel Closing Transmission Time;
- Channel Move Time;
- Non-Occupancy Period.

The steps below define the procedure to determine the above mentioned parameters when a radar burst with a level equal to the *Interference Detection Threshold* is generated on the channel of operation of the RLAN (*In-Service Monitoring*).

- a channel outside 5 150 MHz to 5 250 MHz is selected from the stated operating frequency range(s);
- when the UUT is an RLAN device operating as a Slave (with or without Radar Interference Detection Function), an RLAN device operating as a Master will be used to allow the UUT to associate with the Master. When the UUT is a Master, an RLAN device operating as a Slave will be used and it is assumed that the Slave will associate with the UUT (Master). In both cases, the signal generator shall be connected to the Master;
- the UUT transmits a test transmission sequence on the selected channel;

- d) at a certain time T_0 the signal generator starts generating one of the radar test patterns defined in table D.4 at a level defined in clause 5.3.7.1 on the selected channel. T_1 denotes the end of the first radar burst;
- e) the transmissions of the UUT following instant T_1 on the selected channel shall be observed for a duration of at least 10 s. The aggregate duration of all transmissions from the UUT during the observation time (*Channel Closing Transmission Time*) shall be noted and compared to the limit defined in table D.1:

NOTE: The aggregate duration of all transmissions of the UUT does not include quiet periods in between transmissions of the UUT;

- f) T_2 denotes the instant when the UUT has ceased all transmissions on the channel. The time difference between T_1 and T_2 shall be measured. This value (*Channel Move Time*) shall be noted and compared with the limit defined in table D.1;
- g) when the UUT is an RLAN device operating as a Master, following instant T_2 , the selected channel shall be monitored for an additional 30 minutes (*Non-Occupancy Period*) until instant T_3 , to verify that the UUT does not resume any transmissions on this channel;
- h) the test shall be repeated using each of the radar signals defined in table D.4;
- i) when the UUT is an RLAN device operating as a Slave with a Radar Interference Detection Function the steps a) to h) shall be repeated with the generator connected to the UUT. See also table D.3.

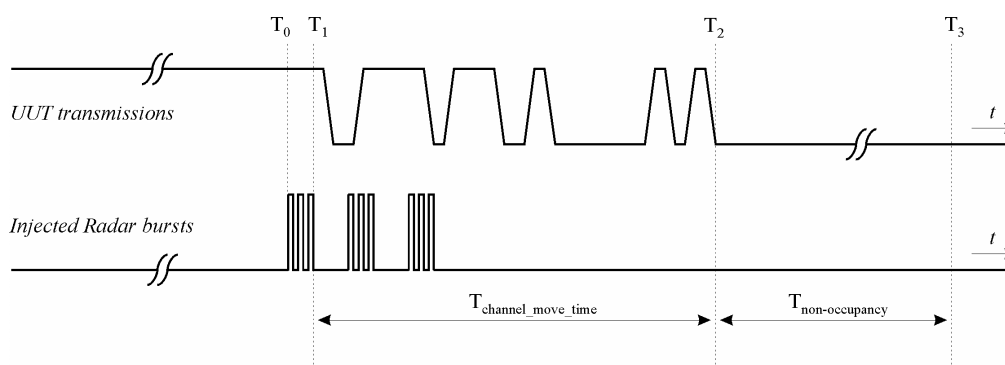

Figure 9: Channel Closing Transmission Time & Channel Clearing Time

5.3.7.2.2 Radiated measurement

This method shall only be used for integral antenna equipment that does not have a temporary antenna connector provided. The test set up as described in annex B and applicable measurement procedures as described in annex C shall be used to test the different DFS features of the UUT. The test procedure is further as described under clause 5.3.7.2.1.

Annex A (normative): The EN Requirements Table (EN-RT)

Notwithstanding the provisions of the copyright clause related to the text of the present document, ETSI grants that users of the present document may freely reproduce the EN-RT proforma in this annex so that it can be used for its intended purposes and may further publish the completed EN-RT.

The EN Requirements Table (EN-RT) serves a number of purposes, as follows:

- it provides a tabular summary of all the requirements;
- it shows the status of each EN-R, whether it is essential to implement in all circumstances (Mandatory), or whether the requirement is dependent on the supplier having chosen to support a particular optional service or functionality (Optional). In particular it enables the EN-Rs associated with a particular optional service or functionality to be grouped and identified;
- when completed in respect of a particular equipment it provides a means to undertake the static assessment of conformity with the EN.

Table A.1: EN Requirements Table (EN-RT)

EN Reference		EN 301 893			Comment
No.	Reference	EN-R (note)	Status		
1	4.2	Carrier frequencies	M		
2	4.3	RF output power, Transmit Power Control (TPC): and power density	M		
3	4.4.1	Transmitter unwanted emissions outside the 5 GHz RLAN bands	M		
4	4.4.2	Transmitter unwanted emissions within the 5 GHz RLAN bands	M		
5	4.5	Receiver spurious emissions	M		
6	4.6	Dynamic Frequency Selection (DFS)	M		
NOTE: These EN-Rs are justified under Article 3.2 of the R&TTE Directive [1].					

Key to columns:

No: table entry number;

Reference: clause reference number of conformance requirement within the present document;

EN-R: title of conformance requirement within the present document;

Status: status of the entry as follows:

M mandatory, shall be implemented under all circumstances;

O optional, may be provided, but if provided shall be implemented in accordance with the requirements;

O.n this status is used for mutually exclusive or selectable options among a set. The integer "n" shall refer to a unique group of options within the EN-RT. A footnote to the EN-RT shall explicitly state what the requirement is for each numbered group. For example, "It is mandatory to support at least one of these options", or, "It is mandatory to support exactly one of these options".

Comments to be completed as required.

Annex B (normative): Test sites and arrangements for radiated measurements

B.1 Test sites

B.1.1 Open air test sites

The term "open air" should be understood from an electromagnetic point of view. Such a test site may be really in open air or alternatively with walls and ceiling transparent to the radio waves at the frequencies considered.

An open air test site may be used to perform the measurements using the radiated measurement methods described in clause 5. Absolute or relative measurements may be performed on transmitters or on receivers; absolute measurements of field strength require a calibration of the test site. Above 1 GHz, measurements should be done in anechoic conditions. This may be met by semi anechoic sites provided reflections are avoided.

For measurements at frequencies below 1 GHz, a measurement distance appropriate to the frequency shall be used. For frequencies above 1 GHz, any suitable measuring distance may be used. The equipment size (excluding the antenna) shall be less than 20 % of the measuring distance. The height of the equipment or of the substitution antenna shall be 1,5 m; the height of the test antenna (transmit or receive) shall vary between 1 and 4 m.

Sufficient precautions shall be taken to ensure that reflections from extraneous objects adjacent to the site do not degrade the measurement results, in particular:

- no extraneous conducting objects having any dimension in excess of a quarter wavelength of the highest frequency tested shall be in the immediate vicinity of the site according to CISPR 16-1 [6] ;
- all cables shall be as short as possible; as much of the cables as possible shall be on the ground plane or preferably below; and the low impedance cables shall be screened.

The general measurement arrangement is shown in figure B.1.

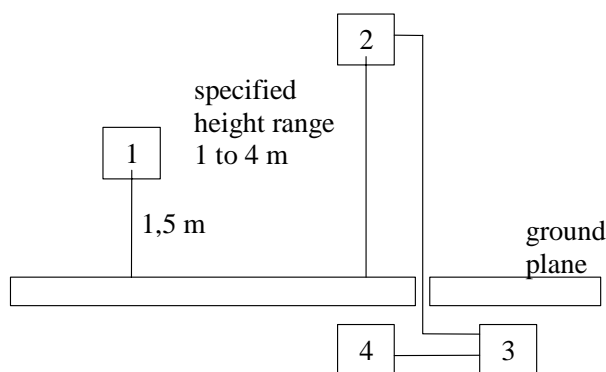

- 1: Equipment under test.
- 2: Test antenna.
- 3: High pass filter (as required).
- 4: Spectrum analyser or measuring receiver.

Figure B.1: Measuring arrangement

B.1.2 Anechoic chamber

B.1.2.1 General

An anechoic chamber is a well shielded chamber covered inside with radio frequency absorbing material and simulating a free space environment. It is an alternative site on which to perform the measurements using the radiated measurement methods described in clause 5.7. Absolute or relative measurements may be performed on transmitters or on receivers. Absolute measurements of field strength require a calibration of the anechoic chamber. The test antenna, equipment under test and substitution antenna are used in a way similar to that at the open air test site, but are all located at the same fixed height above the floor.

B.1.2.2 Description

An anechoic chamber should meet the requirements for shielding loss and wall return loss as shown in figure B.2. Figure B.3 shows an example of the construction of an anechoic chamber having a base area of 5 m by 10 m and a height of 5 m. The ceiling and walls are coated with pyramidically formed absorbers approximately 1 m high. The base is covered with special absorbers which form the floor. The available internal dimensions of the chamber are 3 m x 8 m x 3 m, so that a maximum measuring distance of 5 m in the middle axis of this chamber is available. The floor absorbers reject floor reflections so that the antenna height need not be changed. Anechoic chambers of other dimensions may be used.

B.1.2.3 Influence of parasitic reflections

For free-space propagation in the far field, the relationship of the field strength E and the distance R is given by $E = E_0 \times (R_0/R)$, where E_0 is the reference field strength and R_0 is the reference distance. This relationship allows relative measurements to be made as all constants are eliminated within the ratio and neither cable attenuation nor antenna mismatch or antenna dimensions are of importance.

If the logarithm of the foregoing equation is used, the deviation from the ideal curve may be easily seen because the ideal correlation of field strength and distance appears as a straight line. The deviations occurring in practice are then clearly visible. This indirect method shows quickly and easily any disturbances due to reflections and is far less difficult than the direct measurement of reflection attenuation.

With an anechoic chamber of the dimensions given above at low frequencies below 100 MHz there are no far field conditions, but the wall reflections are stronger, so that careful calibration is necessary. In the medium frequency range from 100 MHz to 1 GHz the dependence of the field strength to the distance meets the expectations very well. Above 1 GHz, because more reflections will occur, the dependence of the field strength to the distance will not correlate so closely.

B.1.2.4 Calibration and mode of use

The calibration and mode of use is the same as for an open air test site, the only difference being that the test antenna does not need to be raised and lowered whilst searching for a maximum, which simplifies the method of measurement.

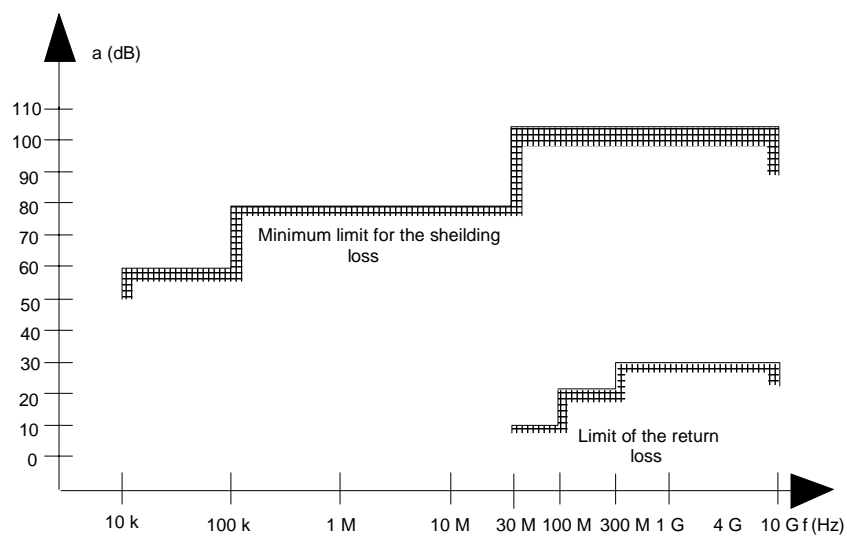

Figure B.2: Specification for shielding and reflections

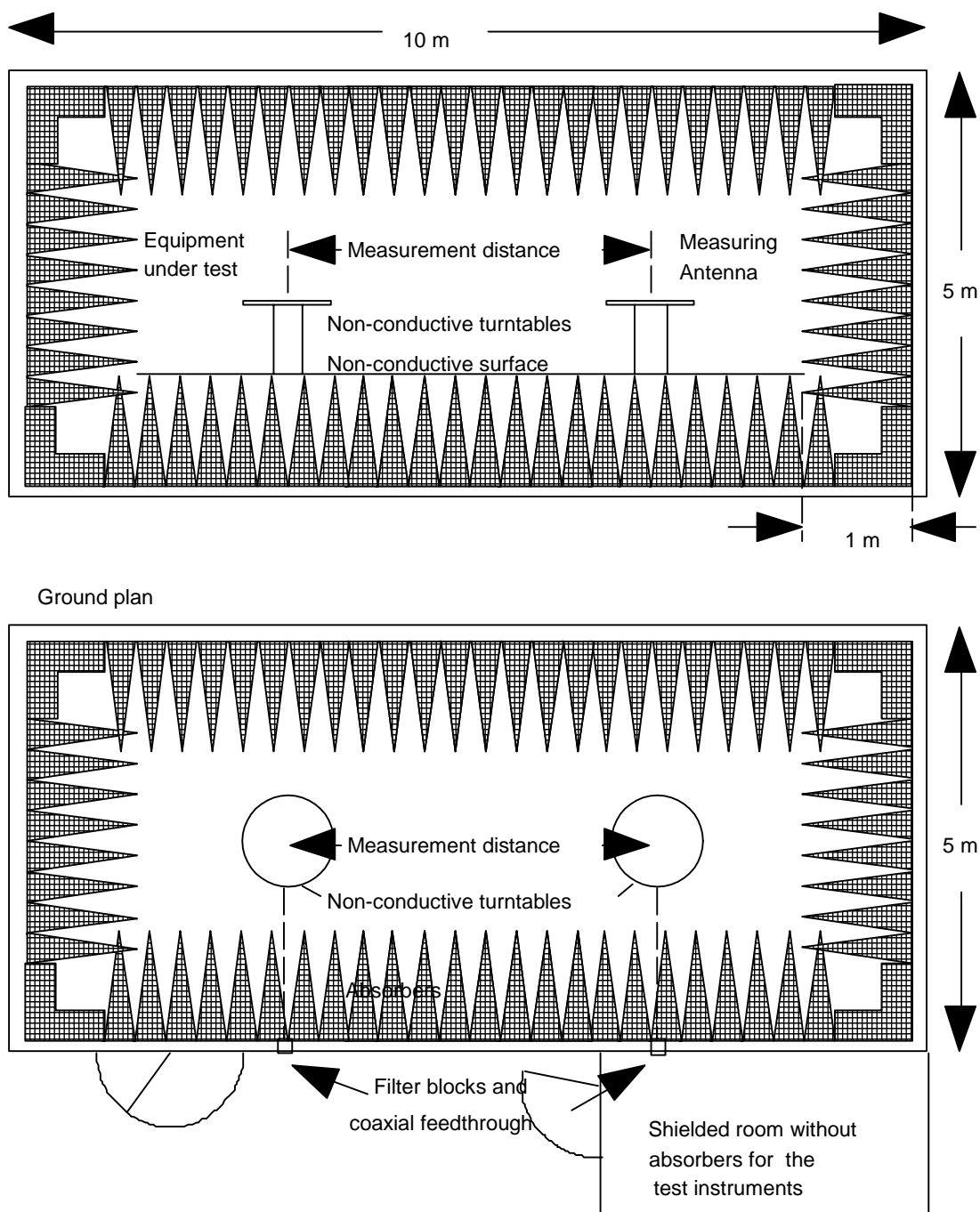

Figure B.3: Anechoic shielded chamber for simulated free space measurements

B.2 Test antenna

When the test site is used for radiation measurements the test antenna shall be used to detect the field from both the test sample and the substitution antenna. When the test site is used for the measurement of receiver characteristics the antenna shall be used as a transmitting antenna. This antenna shall be mounted on a support capable of allowing the antenna to be used in either horizontal or vertical polarization and for the height of its centre above the ground to be varied over the specified range. Preferably test antennas with pronounced directivity should be used. The size of the test antenna along the measurement axis shall not exceed 20 % of the measuring distance.

B.3 Substitution antenna

The substitution antenna shall be used to replace the UUT in substitution measurements. For measurements below 1 GHz the substitution antenna shall be a half wavelength dipole resonant at the frequency under consideration, or a shortened dipole, calibrated to the half wavelength dipole. For measurements between 1 GHz and 4 GHz either a half wavelength dipole or a horn radiator may be used. For measurements above 4 GHz a horn radiator shall be used. The centre of this antenna shall coincide with the reference point of the test sample it has replaced. This reference point shall be the volume centre of the sample when its antenna is mounted inside the cabinet, or the point where an outside antenna is connected to the cabinet.

The distance between the lower extremity of the dipole and the ground shall be at least 30 cm.

NOTE: The gain of a horn antenna is generally expressed relative to an isotropic radiator.

Annex C (normative): General description of measurement

This annex gives the general methods of measurements for RF signals using the test sites and arrangements described in annex B.

C.1 Conducted measurements

Conducted measurements may be applied to equipment provided with an antenna connector e.g. by means of a spectrum analyser.

C.2 Radiated measurements

Radiated measurements shall be performed with the aid of a test antenna and measurement instruments as described in annex B. The test antenna and measurement instrument shall be calibrated according to the procedure defined in this annex. The equipment to be measured and the test antenna shall be oriented to obtain the maximum emitted power level. This position shall be recorded in the measurement report. The frequency range shall be measured in this position.

Radiated measurements should be performed in an anechoic chamber. For other test sites corrections may be needed (see annex B). The following test procedure applies:

- a test site which fulfils the requirements of the specified frequency range of this measurement shall be used. The test antenna shall be oriented initially for vertical polarization unless otherwise stated and the transmitter under test shall be placed on the support in its standard position (clause B.1.1) and switched on;
- for average power measurements a non-selective voltmeter or wideband spectrum analyser shall be used. For other measurements a spectrum analyser or selective voltmeter shall be used and tuned to the measurement frequency.

In either case a) or b), the test antenna shall be raised or lowered, if necessary, through the specified height range until the maximum signal level is detected on the spectrum analyser or selective voltmeter.

The test antenna need not be raised or lowered if the measurement is carried out on a test site according to clause B.1.2.

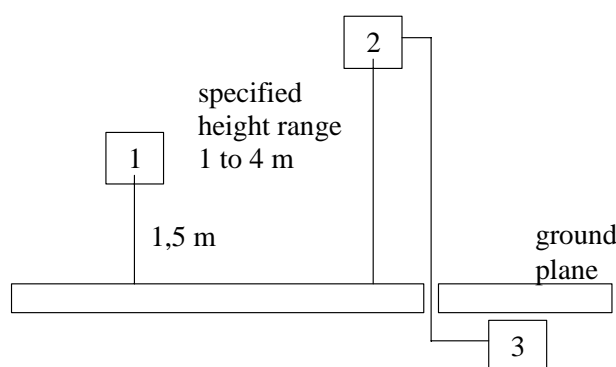

- 1: Equipment under test.
2: Test antenna.
3: Spectrum analyser or measuring receiver.

Figure C.1: Measurement arrangement 1

- the transmitter shall be rotated through 360° about a vertical axis until a higher maximum signal is received;
- the test antenna shall be raised or lowered again, if necessary, through the specified height range until a maximum is obtained. This level shall be recorded.

NOTE: This maximum may be a lower value than the value obtainable at heights outside the specified limits.

The test antenna need not be raised or lowered if the measurement is carried out on a test site according to clause B.1.2. This measurement shall be repeated for horizontal polarization. The result of the measurement shall be taken as the sum of the powers measured with vertical and horizontal polarization.

C.3 Substitution measurement

The actual signal generated by the measured equipment may be determined by means of a substitution measurement in which a known signal source replaces the device to be measured, see figure C.2. This method of measurement should be used in an anechoic chamber. For other test sites corrections may be needed, see annex B.

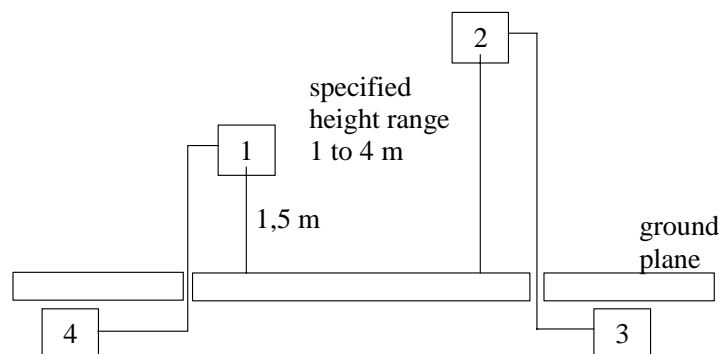

- 1: Equipment under test.
- 2: Test antenna.
- 3: Spectrum analyser or selective voltmeter.
- 4: Signal generator.

Figure C.2: Measurement arrangement 2

Using measurement arrangement 2, figure C.2, the substitution antenna shall replace the transmitter antenna in the same position and in vertical polarization. The frequency of the signal generator shall be adjusted to the measurement frequency. The test antenna shall be raised or lowered, if necessary, to ensure that the maximum signal is still received. The input signal to the substitution antenna shall be adjusted in level until an equal or a known related level to that detected from the transmitter is obtained in the test receiver.

The test antenna need not be raised or lowered if the measurement is carried out on a test site according to clause B.1.2.

The radiated power is equal to the power supplied by the signal generator, increased by the known relationship if necessary and after corrections due to the gain of the substitution antenna and the cable loss between the signal generator and the substitution antenna.

This measurement shall be repeated with horizontal polarization. The result of the measurement is the higher power obtained from the two measurements with the indication of the corresponding polarization.

Annex D (normative): DFS parameters

Table D.1: DFS requirement values

Parameter	Value
Channel Availability Check Time	60 s
Channel Move Time	10 s
Channel Closing Transmission Time	260 ms

Table D.2: Interference Threshold values, Master

Maximum Transmit Power	Value (see note)
≥ 200 mW	-64 dBm
< 200 mW	-62 dBm

NOTE: This is the level at the input of the receiver assuming a 0 dBi receive antenna.

Table D.3: Interference Threshold values, Slave

Maximum Transmit Power	Value (see note)
≥ 200 mW	-64 dBm
< 200 mW	N/A

NOTE: This is the level at the input of the receiver assuming a 0 dBi receive antenna.

Table D.4: Parameters of DFS test signals

Radar test signal	Pulse repetition frequency PRF [pps]	Pulse width W [μ s]	Burst length L [ms] / No. of pulses (see note 1)	Burst Period B [sec] (see note 2)
Radar signal 1	700	1	26/18	10
Radar signal 2	1800	1	5/10	2
Radar signal 3	330	2	210/70	60

NOTE 1: This represents the number of pulses seen at the RLAN per radar scan: $N = \{[\text{antenna beamwidth (deg)}] \times \{\text{pulse repetition rate (pps)}\}\} / \{[\text{scan rate (deg/s)}]\}$.

NOTE 2: Burst period represents the time between successive scans of the radar beam: $B = 360 / \{\text{scan rate (deg/s)}\}$.

NOTE 3: Radar bandwidth is less than that of the RLAN.

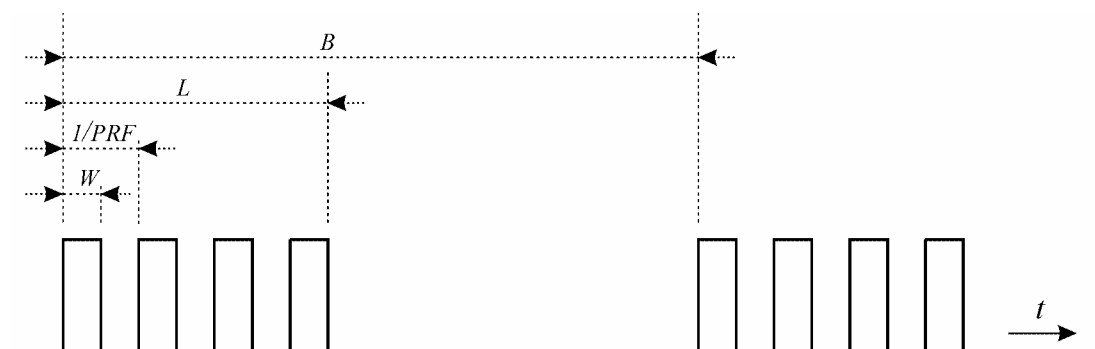

Figure D.1: General structure of the DFS test transmission sequences

Annex E (informative): The EN title in the official languages

Language	EN title
Danish	Bredbåndsradioksesnet (BRAN); 5GHz high-performance RLAN; Harmoniseret EN omfatter essentielle krav fra artikel 3.2 af R&TTE direktiv
Dutch	Breedband netwerken met nadio toegang (BRAN). 5 GHz high performance RLAN apparatuur. Geharmoniseerde EN betreffende de wezenlijke vereisten, als aangegeven in artikel 3, lid 2, van de R&TTE Richtlijn
English	Broadband Radio Access Networks (BRAN); 5 GHz high performance RLAN; Harmonized EN covering essential requirements of article 3.2 of the R&TTE Directive
Finnish	Laajakaistaiset radioliityntäverkot (BRAN); 5 GHz korkean suorituskyvyn RLAN; Yhdenmukaistettu standardi (EN), joka kattaa R&TTE-direktiivin artiklan 3.2 mukaiset olennaiset vaatimukset
French	Réseaux radio fréquence large bande (BRAN); Réseaux locaux radio haute performance 5 GHz ; EN harmonisé couvrant les exigences essentielles de l'article 3.2 des Directives R&TTE
German	Breitbandige funkzugangnetze (BRAN); Lokale funknetze mit hoher Leistung im 5GHz Band; Harmonisierte Europäische Norm (EN) für die grundlegenden Anforderungen des Artikels 3.2 der Funk- und Telekommunikationsendgerätedirektive (R&TTE directive)
Greek	Ευρυζωνικά Δίκτυα Ραδιοεπικοινωνίας (BRAN); Υψηλής απόδοσης RLAN στους 5 GHz; Εναρμονισμένη EN που καλύπτει τις βασικές προϋποθέσεις του άρθρου 3.2 της οδηγίας R&TTE
Italian	Reti di accesso radio a larga banda (BRAN); 5GHz RLAN ad alte prestazioni; EN armonizzati soddisfacenti i requisiti dell'articolo 3.2 della Direttiva R&TTE
Portuguese	Redes de Acesso Rádio em Banda Larga (BRAN); RLAN de alto desempenho na faixa dos 5 GHz; EN harmonizada cobrindo os requisitos essenciais no âmbito do Artigo 3.2 da Directiva R&TTE
Spanish	Redes de acceso por radio de banda ancha (BRAN); RLAN de alto rendimiento en la banda de 5 GHz; Estandar ETSI cubriendo los aspectos esenciales del artículo 3.2 de la Directiva R&TTE
Swedish	Bredbandsradio-accessnät (BRAN); 5 GHz hög kapacitet RLAN; Harmoniserad EN omfattande väsentliga krav enligt artikel 3.2 i R&TTE-direktivet

Annex F (informative): Bibliography

- ITU-R Recommendation M.1652: "Dynamic frequency selection in wireless access systems including radio local area networks for the purpose of protecting the radiodetermination service in the 5 GHz band".

History

Document history			
V1.1.1	January 2001	Public Enquiry	PE 20010525: 2001-01-24 to 2001-05-25
V1.2.1	July 2002	Public Enquiry	PE 20021129: 2002-07-31 to 2002-11-29
V1.2.2	June 2003	Vote	V 20030801: 2003-06-02 to 2003-08-01
V1.2.3	August 2003	Publication	