

**Electromagnetic compatibility
and Radio spectrum Matters (ERM);
VHF air-ground Digital Link (VDL) Mode 4 radio equipment;
Technical characteristics and methods of measurement
for ground-based equipment;
Part 3: Additional broadcast aspects**



Reference

REN/ERM-TG25-029-3

Keywords

aeronautical, digital, radio, testing, VHF

ETSI

650 Route des Lucioles
F-06921 Sophia Antipolis Cedex - FRANCE

Tel.: +33 4 92 94 42 00 Fax: +33 4 93 65 47 16

Siret N° 348 623 562 00017 - NAF 742 C
Association à but non lucratif enregistrée à la
Sous-Préfecture de Grasse (06) N° 7803/88

Important notice

Individual copies of the present document can be downloaded from:

<http://www.etsi.org>

The present document may be made available in more than one electronic version or in print. In any case of existing or perceived difference in contents between such versions, the reference version is the Portable Document Format (PDF). In case of dispute, the reference shall be the printing on ETSI printers of the PDF version kept on a specific network drive within ETSI Secretariat.

Users of the present document should be aware that the document may be subject to revision or change of status. Information on the current status of this and other ETSI documents is available at

<http://portal.etsi.org/tb/status/status.asp>

If you find errors in the present document, please send your comment to one of the following services:

http://portal.etsi.org/chaicor/ETSI_support.asp

Copyright Notification

No part may be reproduced except as authorized by written permission.
The copyright and the foregoing restriction extend to reproduction in all media.

© European Telecommunications Standards Institute 2006.
All rights reserved.

DECT™, **PLUGTESTS™** and **UMTS™** are Trade Marks of ETSI registered for the benefit of its Members.
TIPHON™ and the **TIPHON logo** are Trade Marks currently being registered by ETSI for the benefit of its Members.
3GPP™ is a Trade Mark of ETSI registered for the benefit of its Members and of the 3GPP Organizational Partners.

Contents

Intellectual Property Rights	5
Foreword.....	5
Introduction	6
1 Scope	7
2 References	8
3 Definitions and abbreviations.....	9
3.1 Definitions	9
3.1.1 Basic reference model definitions.....	9
3.1.2 Service conventions definitions	9
3.1.3 General definitions.....	9
3.2 Abbreviations	10
4 General description of VDL Mode 4 ground station link layer.....	11
4.1 General	11
4.2 Automatic Dependant Surveillance-Broadcast.....	12
4.3 Traffic Information Service-Broadcast.....	13
4.4 Flight Information Service-Broadcast	13
4.5 GNSS Augmentation Service-Broadcast (GNS-B)	14
4.6 Ground Station Coordination	15
5 Minimum performance specification under standard test conditions.....	16
5.1 Requirements for ADS-B	16
5.1.1 Information Field Formats	16
5.1.2 ADS-B Request	26
5.1.2.1 ADS-B request format.....	26
5.1.2.2 Sleep Mode	27
5.1.2.3 Automatic Selection of Variable Information Fields	27
5.1.3 Default ADS-B Reporting	29
5.1.4 ADS-B Procedures.....	29
5.1.5 CTRL Parameters	30
5.1.5.1 Directory of Service (DOS) message	30
5.1.5.2 Channel Management Parameter	30
5.1.6 Definitions for Compact Position Reporting	39
5.1.6.1 Information Field Offset Encoding	39
5.1.6.2 Information Field Offset Decoding.....	41
5.1.6.3 Patch ID Encoding	42
5.1.6.4 Patch ID Decoding.....	43
5.1.7 Encoding of UDATA (udid)	43
5.2 Requirements for TIS-B	44
5.2.1 Traffic Information Volume (TIV)	44
5.2.2 Message transmission	44
5.2.2.1 Management messages.....	44
5.2.2.2 Target messages	45
5.2.2.3 Airport operation.....	45
5.2.3 Message format.....	46
5.2.4 Management message.....	47
5.2.5 Aircraft target messages (airborne TIV).....	49
5.2.6 Aircraft target messages (ground TIV).....	51
5.2.7 Ground vehicle target messages (ground TIV).....	52
5.2.8 TIS-B offset encoding.....	53
5.3 Requirements for FIS-B	57
5.3.1 Message format.....	57
5.3.2 Meteorological Aerodrome Report (METAR) message	58
5.3.3 Special Observations and Reports (SPECI) message.....	66
5.3.4 Automatic Terminal Information Service (ATIS) message	67

5.3.5	Runway Condition (RCN) message	69
5.3.6	SIGNificant METeorological Information (SIGMET) message.....	73
5.3.7	Temporary Segregated Areas (TSA) message	74
5.3.8	FIS-B report request message	77
5.3.9	Ground system functions	78
5.4	Requirements for GNSS Augmentation Service Broadcast (GNS-B) message	79
5.4.1	Message format.....	79
5.4.2	Message Type 1	79
5.4.3	Message Type 2	83
5.4.4	Message Type 4	87
5.4.5	CRC Calculation.....	93
5.4.5.1	GNS-B CRC.....	93
5.4.5.2	FAS CRC	94
5.4.5.3	Ephemeris CRC.....	94
6	General design requirements	95
7	Protocol test procedures	95
7.1	General	95
7.2	Required test rig	96
7.3	Protocol test-suite description methodology	98
7.4	Detailed protocol test procedures	98
7.4.1	Test-suite overview.....	98
7.4.2	Declarations	100
7.4.3	Constraints	100
7.4.3.1	Abbreviations	100
7.4.3.1.1	Subfield mnemonics	101
7.4.3.1.2	Station addresses and positions	104
7.4.3.1.3	Tables of values for use in CPR test cases	106
7.4.3.1.4	Tables of values for use in content checking test cases	115
7.4.3.1.5	VDL4 Burst formats	149
7.4.3.2	Test cases	189
7.4.3.2.1	Test case macros	189
7.4.3.2.2	Test case descriptions	190
Annex A (informative):	Cross reference matrix	245
Annex B (informative):	Bibliography	256
History		262

Intellectual Property Rights

IPRs essential or potentially essential to the present document may have been declared to ETSI. The information pertaining to these essential IPRs, if any, is publicly available for **ETSI members and non-members**, and can be found in ETSI SR 000 314: "*Intellectual Property Rights (IPRs); Essential, or potentially Essential, IPRs notified to ETSI in respect of ETSI standards*", which is available from the ETSI Secretariat. Latest updates are available on the ETSI Web server (<http://webapp.etsi.org/IPR/home.asp>).

Pursuant to the ETSI IPR Policy, no investigation, including IPR searches, has been carried out by ETSI. No guarantee can be given as to the existence of other IPRs not referenced in ETSI SR 000 314 (or the updates on the ETSI Web server) which are, or may be, or may become, essential to the present document.

Foreword

This European Standard (Telecommunications series) has been produced by ETSI Technical Committee Electromagnetic compatibility and Radio spectrum Matters (ERM), and is now submitted for the ETSI standards One-step Approval Procedure.

The present document is part 3 of a multi-part deliverable covering the VHF air-ground Digital Link (VDL) Mode 4 radio equipment; Technical characteristics and methods of measurement for ground-based equipment, as identified below:

- Part 1: "EN for ground equipment";
- Part 2: "General description and data link layer";
- Part 3: "Additional broadcast aspects";**
- Part 4: "Point-to-point functions";
- Part 5: "VDL 4 ground based equipment compliance with the SES 552/2004 interoperability Regulation";
- Part 6: "Harmonized EN covering essential requirements of article 3.2 of the R&TTE Directive".

The present document is accompanied by an equivalent airborne standard, EN 302 842 [9] parts 1 to 5, covering the VHF air-ground Digital Link (VDL) Mode 4 radio equipment; Technical characteristics and methods of measurement for airborne equipment.

Proposed national transposition dates	
Date of latest announcement of this EN (doa):	3 months after ETSI publication
Date of latest publication of new National Standard or endorsement of this EN (dop/e):	6 months after doa
Date of withdrawal of any conflicting National Standard (dow):	6 months after doa

Introduction

The present document is part of a set of deliverables developed by ETSI and is designed to fit in a modular structure to cover all radio and telecommunications terminal equipment within the scope of the R&TTE Directive [11]. The modular structure is shown in EG 201 399 [13].

The present document states the technical specifications for Very High Frequency (VHF) Digital Link (VDL) Mode 4 ground-based radio transmitters, transceivers and receivers for air-ground communications operating in the VHF band, using Gaussian-filtered Frequency Shift Keying (GFSK) Modulation with 25 kHz channel spacing and capable of tuning to any of the 25 kHz channels from 118,000 MHz to 136,975 MHz as defined in ICAO VHF Digital Link (VDL) Standards and Recommended Practices (SARPs) [10].

The present document considers the additional broadcast functionality required to support ADS-B, TIS-B, FIS-B, and GNS-B services.

The present document may be used to produce tests for the assessment of the performance of the equipment. The performance of the equipment submitted for type testing should be representative of the performance of the corresponding production model.

The present document has been written on the assumption that:

- the type test measurements will be performed only once, in an accredited test laboratory and the measurements accepted by the various authorities in order to grant type approval;
- if equipment available on the market is required to be checked it will be tested in accordance with the methods of measurement specified in the present document or a documented alternative approved by the certifying authority;
- equipment comply with EN 301 489-22 [2], EN 301 842-1 [4] and EN 301 842-2 [5].

The present document also indicates VDL Mode 4 compliance with the SES 552/2004 interoperability Regulation [12].

1 Scope

The present document applies to the following radio equipment types:

- Very High Frequency (VHF) Digital Link (VDL) Mode 4 ground-based radio transmitters and receivers for air-ground communications operating in the VHF band, using Gaussian-filtered Frequency Shift Keying (GFSK) Modulation with 25 kHz channel spacing and capable of tuning to any of the 25 kHz channels from 118,000 MHz to 136,975 MHz as defined in ICAO VHF Digital Link (VDL) Standards and Recommended Practices (SARPs) [10].

The present document provides part 3 of the technical specifications.

The present document is designed to ensure that equipment certified to it will be compatible with the relevant ICAO VHF Digital Link (VDL) Standards and Recommended Practices (SARPs) [10] and VDL Mode 4 Technical Manual (TM) [1] and with the SES 552/2004 interoperability Regulation [12].

Manufacturers should note that in future the tuning range for the ground transceivers may also cover any 25 kHz channel from 108,000 MHz to 117,975 MHz.

The scope of the present document is limited to ground stations. The equivalent specification for airborne stations is EN 302 842 [9].

A description of the scope of the VDL Mode 4 system is provided in part 2 of these technical specifications (see EN 301 842-2 [5] clause 1).

EN 301 842-1 [4] deals with tests of the physical layer. EN 301 842-2 [5] deals with tests of the link layer sufficient to support broadcast functionality including requirements and tests sufficient to recognize and respond to transmissions associated with point-to-point communication. The present document provides technical specifications for a VDL Mode 4 ground-based transceiver supporting a full Automatic Dependent Surveillance-Broadcast (ADS-B) capability and, optionally, the additional functionality of either, or a combination of, the following services:

- Traffic Information Service-Broadcast (TIS-B);
- Flight Information Service-Broadcast (FIS-B);
- GNSS Augmentation Service-Broadcast (GNS-B).

The TIS-B, FIS-B or GNS-B functionality in the ground-based equipment is expected to be provided by a TIS-B, FIS-B or GNS-B processor, which could be contained within the VDL Mode 4 transceiver, but could also be housed in a separate physical unit. Therefore to support TIS-B, FIS-B or GNS-B, the minimum functionality demanded of a basic VDL Mode 4 ground-based transceiver unit (i.e. one that does not have a TIS-B, FIS-B or GNS-B processor housed within it) is to receive, from the TIS-B, FIS-B or GNS-B processor, all messages to be transmitted, and to transmit them. In the case of FIS-B there is an additional requirement to receive report request messages (from other VDL4 stations) and to pass those messages to the FIS-B processor.

It should be noted that the specifications for TIS-B, FIS-B and GNS-B in the present document represent a first step towards defining these applications, based on the work carried out as part of the NUP and MEDUP Programmes, and changes to the specifications for these services may therefore occur in the future.

The present document is organized as follows:

- clause 2 provides references to relevant documents;
- clause 3 provides general definitions, abbreviations and symbols used;
- clause 4 describes the VDL Mode 4 ground station functionality to support ADS-B, TIS-B, FIS-B and GNS-B;
- clause 5 provides performance specifications for the VDL Mode 4 ground station supporting ADS-B, TIS-B, FIS-B and GNS-B Services;
- clause 6 provides general design requirements;

- clause 7 provides protocol tests which emphasis the ADS-B, TIS-B, FIS-B and GNS-B functions of the system;
- annex A provides a detailed cross-reference to the relevant requirements contained in [1];
- annex B provides a Bibliography;
- a document history.

Note that the system can support a very wide range of functions. It is not practical to provide specific tests for all aspects of functionality. The approach used is to provide detailed tests for the core functionality to support ADS-B, FIS-B, TIS-B and GNS-B focusing on the system requirements which, if wrongly implemented, could cause a deterioration in the service offered by other VDL Mode 4 stations.

Mandating and Recommendation Phrases

a) "Shall":

the use of the word "Shall" indicates a mandated criterion; i.e. compliance with the particular procedure or specification is mandatory and no alternative may be applied.

b) "Should":

the use of the word "Should" (and phrases such as "It is recommended that...", etc.) indicates that though the procedure or criterion is regarded as the preferred option, alternative procedures, specifications or criteria may be applied, provided that the manufacturer, installer or tester can provide information or data to adequately support and justify the alternative.

2 References

The following documents contain provisions which, through reference in this text, constitute provisions of the present document.

- References are either specific (identified by date of publication and/or edition number or version number) or non-specific.
- For a specific reference, subsequent revisions do not apply.
- For a non-specific reference, the latest version applies.

Referenced documents which are not found to be publicly available in the expected location might be found at <http://docbox.etsi.org/Reference>.

- [1] ICAO Doc 9816 AN/448 (First Edition 2004): "Manual on VHF Digital Link (VDL) Mode 4, Part 2: Detailed Technical Specifications".
- [2] ETSI EN 301 489-22 (V1.3.1): "Electromagnetic compatibility and Radio spectrum Matters (ERM); ElectroMagnetic Compatibility (EMC) standard for radio equipment and services; Part 22: Specific conditions for ground based VHF aeronautical mobile and fixed radio equipment".
- [3] RTCA DO-242A: "Minimum Aviation System Performance Standards for Automatic Dependent Surveillance Broadcast (ADS-B)".
- [4] ETSI EN 301 842-1 (V1.3.1): "Electromagnetic compatibility and Radio spectrum Matters (ERM); VHF air-ground Digital Link (VDL) Mode 4 radio equipment; Technical characteristics and methods of measurement for ground-based equipment; Part 1: EN for ground equipment".
- [5] ETSI EN 301 842-2 (V1.5.1): "Electromagnetic compatibility and Radio spectrum Matters (ERM); VHF air-ground Digital Link (VDL) Mode 4 radio equipment; Technical characteristics and methods of measurement for ground-based equipment; Part 2: General description and data link layer".

- [6] ETSI EN 301 842-4 (V1.2.1): "Electromagnetic compatibility and Radio spectrum Matters (ERM); VHF air-ground Digital Link (VDL) Mode 4 radio equipment; Technical characteristics and methods of measurement for ground-based equipment; Part 4: Point-to-point functions".
- [7] Amendments 76 and 77 to Volume I of Annex 10 to the Convention on International Civil Aviation, International Civil Aviation Organization: appendix B-B2, 3.6 Ground-Based Augmentation System (GBAS).
- [8] Eurocae ED-114 (September 2003): "MOPS for a GBAS ground facility to support CAT I approach and landing".
- [9] ETSI EN 302 842 (all parts): "Electromagnetic compatibility and Radio spectrum Matters (ERM); VHF air-ground and air-air Digital Link (VDL) Mode 4 radio equipment; Technical characteristics and methods of measurement for aeronautical mobile (airborne) equipment".
- [10] ICAO Annex 10 to the Convention on International Civil Aviation: "Aeronautical Telecommunications, Volume III: Communication Systems, Part I: Digital Data Communication Systems, chapter 6".
- [11] Directive 1999/5/EC of the European Parliament and of the Council of 9 March 1999 on radio equipment and telecommunications terminal equipment and the mutual recognition of their conformity (R&TTE Directive).
- [12] Regulation (EC) No 552/2004 of the European Parliament and of the Council of 10 March 2004 on the interoperability of the European Air Traffic Management network (the interoperability Regulation).
- [13] ETSI EG 201 399: "Electromagnetic compatibility and Radio spectrum Matters (ERM); A guide to the production of candidate Harmonized Standards for application under the R&TTE Directive".

3 Definitions and abbreviations

3.1 Definitions

3.1.1 Basic reference model definitions

See EN 301 842-2 [5], clause 3.1.1.

3.1.2 Service conventions definitions

See EN 301 842-2 [5], clause 3.1.2.

3.1.3 General definitions

For the purposes of the present document, the terms and definitions given in EN 301 842-1 [4], clause 3.1.3, EN 301 842-2 [5], clause 3.1.3 and the following apply:

Automatic Dependent Surveillance-Broadcast (ADS-B): surveillance application transmitting parameters, such as position, track, ground speed and time via a broadcast mode data link for use by any air and ground users requiring it

NOTE: ADS-B is a surveillance service based on aircraft self-determination of position/velocity/time and automatic, periodic, broadcast of this information along with auxiliary data such as aircraft identity (ID), intent information and communications control parameters, etc. ADS-B is intended to support multiple high-level applications and associated services such as cockpit display of traffic information, traffic alert and collision avoidance functionality, enhanced traffic management in the air and on the ground, search and rescue support and others.

Automatic Terminal Information Service (ATIS): report generated by a ground station that includes weather conditions, operating procedures, runways and approaches in use, and any other information that may affect the departure, runway, and landing phase of flight

Flight Information Service-Broadcast (FIS-B): uplink broadcast application providing local airborne traffic with information

GNSS augmentation Service-Broadcast (GNS-B): uplink broadcast application providing aircraft with GNSS augmentation and integrity data

METEorological Aerodrome Report (METAR): report generated by a ground station that broadcasts meteorological conditions at aerodromes, officially recoded and communicated at regular intervals

SIGNificant METeorological information (SIGMET): report generated by a ground station that broadcasts information about weather phenomena that may have an impact on aircraft at subsonic, transonic and supersonic cruising levels including thunderstorms, cyclones, turbulence and icing

SPECIAL observations and reports (SPECI): report generated by a ground station that is issued when meteorological conditions change sufficiently to affect aviation operations. The SPECI report contains the same information as a METAR

Traffic Information Service-Broadcast (TIS-B): uplink surveillance service that derives traffic information from one or more ground surveillance sources and broadcasts that information to suitably equipped aircraft or surface vehicles

Traffic Information Volume (TIV): volume of airspace for which surveillance information is provided for all targets

NOTE: Inside the TIV, a pilot knows he can rely on the surveillance picture presented to him; outside the TIV, ADS-B reports may be received but TIS-B reports may not be available.

3.2 Abbreviations

For the purposes of the present document, the following abbreviations apply:

ADS-B	Automatic Dependent Surveillance-Broadcast
ATIS	Automatic Terminal Information Service
CCI	Co-Channel Interference
CPR	Compact Position Reporting
CRC	Cyclic Redundancy Code
DLPDU	Data Link Protocol Data Unit
DLS	Data Link Service
DOS	Directory Of Services
erid	extended reservation ID
EUROCAE	EUROpean Organization for Civil Aviation Equipment
FAS	Final Approach Segment
FIS-B	Flight Information Service-Broadcast
FPAP	Flight Path Alignment Point
fpm	feet per minute
fps	feet per second
FTP	Fictitious Threshold Point
GBAS	Ground-Based Augmentation System
GCID	GNS-B Continuity / Integrity Designator
GFSK	Gaussian filtered Frequency Shift Keying
GLONASS	GLOBAL NAVigation Satellite System (Russian system)
GNS-B	GNSS augmentation Service-Broadcast
GNSS	Global Navigation Satellite System
GPA	Glide Path Angle
GPS	Global Positioning System
GRAS	Ground-based Regional Augmentation System
GSC	Global Signalling Channel
hex	hexadecimal
IA-5	International Alphabet 5
ICAO	International Civil Aviation Organization
ID	IDentity

LTP	Landing Threshold Point
MASPS	Minimum Aviation System Performance Standards
MEDUP	MEDiterranean Update Programme
METAR	METeorological Aerodrome Report
MOPS	Minimum Operational Performance Specification
NEAN	North European ADS-B Network
NIC	Navigation Integrity Category
NM	Nautical Mile
NUP	NEAN Update Programme
PCO	Point of Control and Observation
PRN	Pseudo Random Noise
R&TTE	Radio equipment and Telecommunications Terminal Equipment
RCN	Runway Condition
RF	Radio Frequency
rid	reservation ID
SARPs	Standards And Recommended Practices
SBAS	Space-Based Augmentation System
SIGMET	SIGNificant METeorological event
SPECI	SPECIal observations and reports
SVQ	State Vector Quality
TCH	Threshold Crossing Height
TCP	Trajectory Change Point
TIS-B	Traffic Information Service-Broadcast
TIV	Traffic Information Volume
TV	Transmission Volume
UTC	Universal Time Coordinated
VDL	VHF Digital Link
VHF	Very High Frequency
VSS	VDL Mode 4 Specific Services

In the tables included in the present document to illustrate the format of bursts, the following order is implied:

- a) bit order in each burst subfield shall be indicated by subscript numbers. Bit 1 shall indicate the least significant bit; and
- b) bits shall be transmitted octet by octet, starting with the first octet in each table, and within each octet the rightmost bit (as shown in the tables) shall be transmitted first.

4 General description of VDL Mode 4 ground station link layer

4.1 General

A description of VDL Mode 4 is provided in EN 301 842-2 [5]. This clause provides a description of the assumptions made in the derivation of the requirements for the VDL Mode 4 ground station.

In most respects, the VDL Mode 4 ground station follows the provisions of the ICAO standards material for VDL Mode 4. Within the ICAO standard, there are some requirements that apply explicitly only to airborne stations. A number of other requirements will also not apply because of the assumed services provided by the ground station. For example, it is assumed that the ground station will have no need to support net entry on a timescale shorter than one minute. The assumed services are provided by the ground station and the impact on the requirements is summarized in the rest of clause 4.

The scope of the present document is for a ground station supporting broadcast applications. Hence the ability to support point-to-point communication is not included in the present document. Those requirements are presented in EN 301 842-4 [6].

Note that, although certain protocols will not be used by the ground station, the ability to recognize the use by mobiles of these protocols and to respond in a consistent manner is a ground station requirement and is included in the present document.

4.2 Automatic Dependant Surveillance-Broadcast

Automatic Dependent Surveillance-Broadcast (ADS-B) is a surveillance application in which aircraft, vehicles and ground stations broadcast their identity, position, velocity, time, intent and other information, enabling other aircraft, vehicles and ground stations to develop a surveillance picture. ADS-B relies on the regular and frequent transmission of position reports via a broadcast data link. The position reports are sent periodically by the aircraft with no intervention from the ground. Position reports may be received by any recipient in range of the transmitting aircraft. Recipients may be other aircraft, ground vehicles or fixed ground sites.

ADS-B offers data delivery from aircraft-to-aircraft or from aircraft-to-ground. Transmitting data directly from air-to-air means that there is no need for a ground infrastructure to be present for airborne surveillance to be performed. By using position reports received from surrounding aircraft, a traffic surveillance picture can be generated in the cockpits of all of the aircraft. This potentially allows new applications or new manoeuvres to be performed by pilots.

The transmitting aircraft does not know which, if any, recipients are receiving and processing the position reports. Unlike a point-to-point link, position reports are not acknowledged. The concept with ADS-B is that position reports are transmitted so frequently that the loss of a small number of position reports is not operationally significant.

ADS-B messages are broadcast and received by appropriately equipped participant subsystems. ADS-B subsystems include aircraft, vehicles and ground subsystems. The capabilities of participant subsystems will vary based upon class of equipment. The ADS-B aircraft subsystem may interact with other onboard systems such as flight management systems, pilot display equipment and the aircraft navigation system. The ADS-B ground subsystem may interact with other ground systems such as flight data processing systems, ATM applications and controller display processing equipment.

If received by a data acquisition unit, the position report will be processed with other surveillance data and may be forwarded to a controller/pilot display.

Ground stations play an active part in the ADS-B application by broadcasting their own position (the information is used by other stations in selecting transmission slots). In addition:

- Ground Stations receive and process ADS-B reports from aircraft and other vehicles, passing the results to a surveillance server.
- Ground Stations may also transmit ADS-B requests in order to control the rate and content of the ADS-B reports generated by aircraft and other vehicles.

Figure 4.1 illustrates the context for the ground station supporting ADS-B functions.

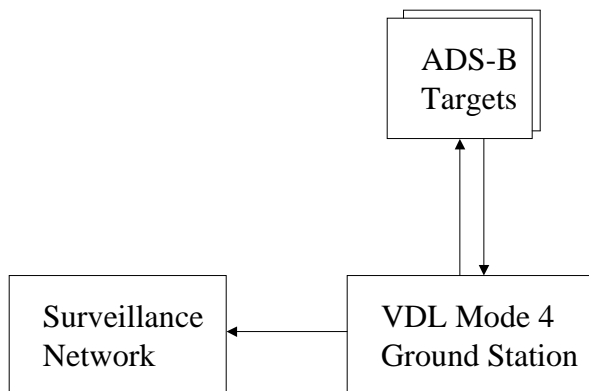

Figure 4.1: Ground station supporting ADS-B functions

The requirements for ADS-B are taken from the ICAO VDL Mode 4 Technical Manual [1].

4.3 Traffic Information Service-Broadcast

Traffic Information Service-Broadcast (TIS-B) is a surveillance service that derives traffic information from one or more ground surveillance sources and broadcasts that information to suitably equipped aircraft or surface vehicles.

The purpose of TIS-B is to complement the surveillance information provided from ADS-B aircraft to ensure that a full surveillance picture is available to airborne systems.

The TIS-B service is provided within an area known as the Traffic Information Volume (TIV), which is the volume of airspace for which surveillance information is provided for all targets. Inside the TIV, a pilot knows he can rely on the surveillance picture presented to him; outside the TIV, ADS-B reports may be received but TIS-B reports may not be available.

A TIS-B service either provides a "full surveillance picture" or a "gap filler service". For the full surveillance picture information is provided on all targets, the "gap filler service" information is only provided for targets which do not support ADS-B via VDL Mode 4.

TIS-B Ground Stations broadcast two main sorts of message:

- a) Management Messages: contain information about the TIS-B service and the TIV.
- b) Target Messages: contain information about aircraft or ground vehicle targets.

Figure 4.2 illustrates the context for the ground station supporting TIS-B functions.

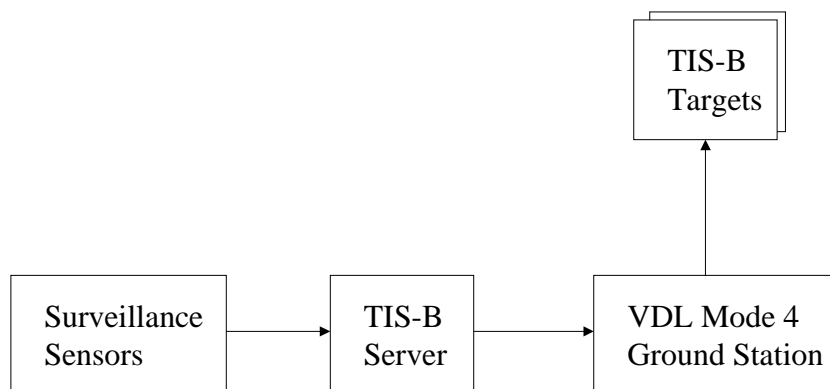

Figure 4.2: Ground station supporting TIS-B functions

The TIS-B server generates Target Messages from information provided by surveillance sensors and passes them on to the VDL Mode 4 ground station for onward broadcast transmission to targets.

The specifications for TIS-B as presented in the present document are derived from the TIS-B Service Description developed by the Nean Update Programme (NUP) and Mediterranean UpDate Programme (MEDUP). A reference to the NUP TIS-B Service Description is contained in the bibliography.

4.4 Flight Information Service-Broadcast

Flight Information Service-Broadcast (FIS-B) is an uplink broadcast application providing local traffic with information concerning:

The following message types are supported:

- a) Meteorological Aerodrome Report (METAR): METAR reports are of meteorological conditions at aerodromes, officially recoded and communicated at regular intervals. Intermediate observations are also recorded and communicated when meteorological conditions change sufficiently to affect aviation operations (see SPECI).
- b) Automatic Terminal Information Service (ATIS): ATIS reports are broadcasts that include weather conditions, operating procedures, runways and approaches in use, and any other information that may affect the departure, runway and landing phase of flight.

- c) Runway Condition (RCN): RCN reports include information about the current runway visual range conditions and any other runway condition that may affect the departure, runway and landing phases of flight.
- d) SIGnificant Meteorological Information (SIGMET): A SIGMET report broadcasts information about weather phenomena which may have an impact on aircraft at subsonic, transonic and supersonic cruising levels including thunderstorms, cyclones, turbulence and icing.
- e) SPECIal Observations and Reports (SPECI): A SPECI message is generated when meteorological conditions change sufficiently to affect aviation operations. The SPECI report contains the same information as a METAR.
- f) REPORT REQUEST: The FIS-B report request enables an aircraft to request specific FIS data.

The FIS-B service is provided within the Transmission Volume (TV) which is defined as the area in which FIS-B reception is possible.

Figure 4.3 illustrates the context for the ground station supporting FIS-B functions.

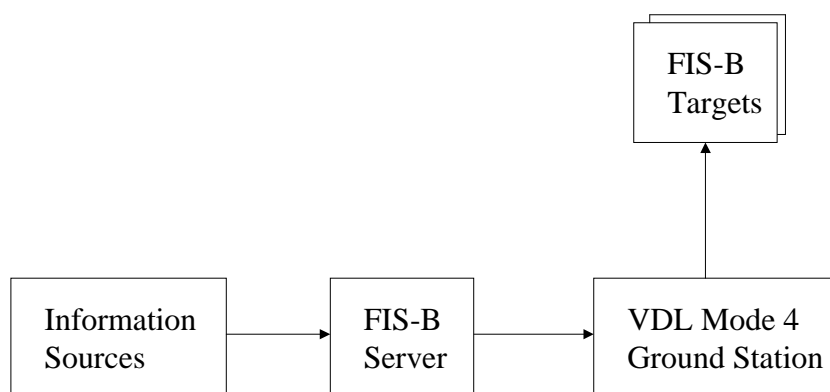

Figure 4.3: Ground station supporting FIS-B functions

The FIS-B server generates reports from relevant information sources and passes them to the VDL Mode 4 ground station for onward broadcast transmission to targets.

The specifications for FIS-B as presented in the present document are derived from the FIS-B Service Description developed by the Near Update Programme (NUP) and Mediterranean Update Programme (MEDUP). A reference to the NUP FIS-B Service Description is contained in the bibliography.

4.5 GNSS Augmentation Service-Broadcast (GNS-B)

Each ground station will need to support a set of minimum requirements for the uplinking of GNSS Augmentation to enhance accuracy and integrity of GNSS. The GNSS Augmentation Service-Broadcast (GNS-B) is intended to support a range of applications such as airport surface surveillance, terminal area and en-route operations, especially at high latitudes where space based augmentation systems is outside of coverage. This function could be provided by a single ground station or as an element within a ground network.

The specifications for GNS-B shall include broadcast of:

- a) Pseudorange corrections (Message Type 1);
- b) GNS-B related data (Message Type 2);
- c) Final Approach Segment Data (Message Type 4).

Clause 5.4 of the present document includes detailed message and encoding descriptions. Broadcast rates and type of message are dependent on the applications that should be supported and are not specified in the present document.

Figure 4.4 illustrates the context for the ground station supporting GNS-B functions.

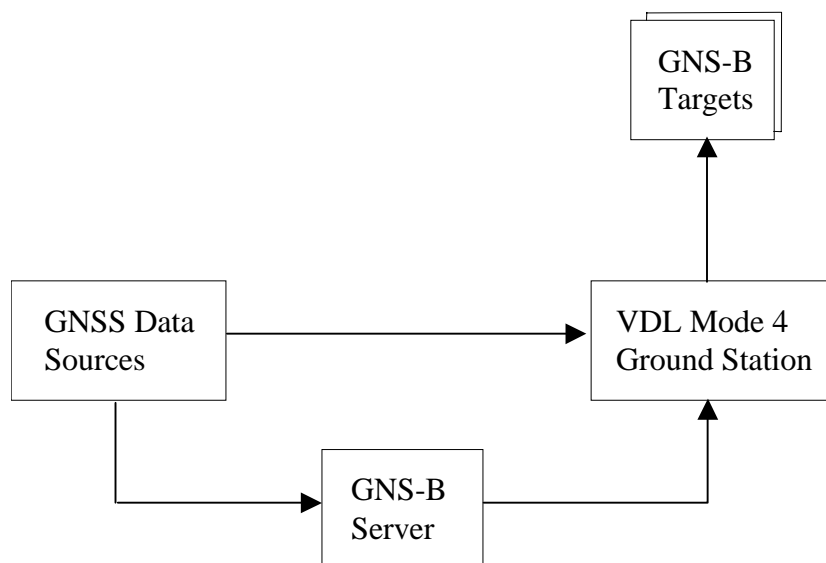

Figure 4.4: Ground station supporting GNS-B functions

The specifications for GNS-B as presented in the present document are derived from the GBAS specifications included in ICAO GNSS SARPs [7] and from the GRAS Service Description developed by the Near Update Programme (NUP) and Mediterranean Update Programme (MEDUP). A reference to the NUP GRAS Service Description is contained in the bibliography.

4.6 Ground Station Coordination

The overall requirements for a network of ground stations are beyond the scope of the current document. However, each ground station will need to support a set of minimum requirements which will enable it to function as an element within a ground network. These minimum requirements shall include:

- a) receiving messages from other elements of a ground network and transmitting these message to airborne stations;
- b) transferring messages received from airborne stations to other elements of the ground network;
- c) receiving control messages from other elements of the ground network specifying slots for transmission of particular messages;
- d) setting up reserved blocks of slots for ground use only;
- e) maintaining a ground UTC-minute time reference frame for coordination with other elements of the ground network.

Ground station coordination requirements have been derived from requirements used for the MEDUP and NUP programmes. It should be noted that much of the MEDUP and NUP programme requirements apply to the ground network as a whole and, specifically, to ground-based servers. The derived requirements provide the minimum functionality to enable the ground station to operate within such a network.

Additional requirements for ground station co-ordination can be found in EN 301 842-2 [5].

5 Minimum performance specification under standard test conditions

5.1 Requirements for ADS-B

5.1.1 Information Field Formats

Requirement reference	
5.1.1.1	The information field formats that have been assigned for use by the ADS-B application shall be as defined in table 5.1.

Table 5.1: ADS-B information fields

Information field ID (id)	ID extension 1 (id1)	ID extension 2 (id2)	Information field name
0 hex	not present	not present	Basic
1 hex	not present	not present	High dynamic
2 hex	not present	not present	Full position
3 hex	not present	not present	Basic ground
4 hex	not present	not present	UTC time
5 hex	not present	not present	Single Slot SVQ
5 - 7 hex	not present	not present	Available for future use
8 hex	not present	not present	Two slot TCP/SVQ
9 hex	not present	not present	Single slot TCP
A hex	0 hex	not present	Available for future use
A hex	1 hex	not present	Aircraft data (call sign, category, status)
A hex	2 - 9 hex	not present	Available for future use
A hex	A hex	0 hex	High resolution
A hex	A hex	1 - 9 hex	Available for future use
A hex	A hex	A hex	Extension (available for future use via further ID extension fields)
A hex	A hex	B - F hex	Available for future use
A hex	B - F hex	not present	Available for future use
B - E hex	not present	not present	Available for future use
F hex	not present	not present	No information field provided

Requirement reference	
5.1.1.2	For each information field, data shall be encoded as defined in tables 5.2 to 5.11.
NOTE:	Bits 1 and 2 in the last row of each of tables 5.2 to 5.11 are reserved for part of the reservation field (e.g. the periodic broadcast reservation field). If a reservation field is appended that does not use these bits, they should be set to zero.

Table 5.2: Information field 0 hex - Basic

Description	Octet	Bit number							
		8	7	6	5	4	3	2	1
information field ID	11	x	x	x	x	0	0	0	0
Surveillance Integrity Level (SIL)	12	sil ₂	sil ₁	lat ₆	lat ₆ ₅	lat ₆ ₄	lat ₆ ₃	lat ₆ ₂	lat ₆ ₁
6-bit latitude offset (lat6)									
6-bit longitude offset (lon6)	13	res	br/gr	lon ₆	lon ₆ ₅	lon ₆ ₄	lon ₆ ₃	lon ₆ ₂	lon ₆ ₁
baro rate/geo rate (br/gr)									
baro/geo offset (bgo)	14	altr ₉	bgo ₇	bgo ₆	bgo ₅	bgo ₄	bgo ₃	bgo ₂	bgo ₁
altitude rate (altr)	15	altr ₈	altr ₇	altr ₆	altr ₅	altr ₄	altr ₃	altr ₂	altr ₁
ground speed (gs)	16	gs ₈	gs ₇	gs ₆	gs ₅	gs ₄	gs ₃	gs ₂	gs ₁
ground track (gt)	17	gs ₁₁	gs ₁₀	gs ₉	gt ₅	gt ₄	gt ₃	gt ₂	gt ₁
	18	gt ₁₁	gt ₁₀	gt ₉	gt ₈	gt ₇	gt ₆		

NOTE: "x" denotes part of fixed data field. "res" denotes currently unused.

Table 5.3: Information field 1 hex - High dynamic

Description	Octet	Bit number							
		8	7	6	5	4	3	2	1
information field ID	11	X	x	x	x	0	0	0	1
baro rate/geo rate (br/gr), baro/geo offset (bgo)	12	br/gr	bgo ₇	bgo ₆	bgo ₅	bgo ₄	bgo ₃	bgo ₂	bgo ₁
altitude rate (altr)	13	altr ₈	altr ₇	altr ₆	altr ₅	altr ₄	altr ₃	altr ₂	altr ₁
rate uncertainty (nucr)	14	altr ₉	res	sil ₂	sil ₁	gs ₁₂	gs ₁₁	gs ₁₀	gs ₉
ground speed (gs)	15	gs ₈	gs ₇	gs ₆	gs ₅	gs ₄	gs ₃	gs ₂	gs ₁
4-bit longitude offset (lon4), 4-bit latitude offset (lat4)	16	lon ₄ ₄	lon ₄ ₃	lon ₄ ₂	lon ₄ ₁	lat ₄ ₄	lat ₄ ₃	lat ₄ ₂	lat ₄ ₁
ground track (gt)	17	gt ₈	gt ₇	gt ₆	gt ₅	gt ₄	gt ₃	gt ₂	gt ₁
	18	gt ₁₂	gt ₁₁	gt ₁₀	gt ₉	res	res		

NOTE 1: "x" denotes part of fixed data field.
NOTE 2: "res" denotes currently unused.

Table 5.4: Information field 2 hex - Full position

Description	Octet	Bit number							
		8	7	6	5	4	3	2	1
information field ID	11	X	x	x	x	0	0	1	0
6-bit latitude offset (lat6)	12	pid ₁₀	pid ₉	lat ₆	lat ₆ ₅	lat ₆ ₄	lat ₆ ₃	lat ₆ ₂	lat ₆ ₁
patch ID (pid)	13	pid ₈	pid ₇	pid ₆	pid ₅	pid ₄	pid ₃	pid ₂	pid ₁
baro/geo offset (bgo)	14	gt ₁₁	bgo ₇	bgo ₆	bgo ₅	bgo ₄	bgo ₃	bgo ₂	bgo ₁
6-bit longitude offset (lon6)	15	gt ₁₀	gt ₉	lon ₆	lon ₆ ₅	lon ₆ ₄	lon ₆ ₃	lon ₆ ₂	lon ₆ ₁
ground track (gt)	16	gt ₈	gt ₇	gt ₆	gt ₅	gt ₄	gt ₃	gt ₂	gt ₁
ground speed (gs)	17	gs ₈	gs ₇	gs ₆	gs ₅	gs ₄	gs ₃	gs ₂	gs ₁
Surveillance Integrity Level (sil)	18	gs ₁₁	gs ₁₀	gs ₉	res	sil ₂	sil ₁		

NOTE: "x" denotes part of fixed data field.

Table 5.5: Information field 3 hex - Basic ground

Description	Octet	Bit number							
		8	7	6	5	4	3	2	1
information field ID	11	x	x	x	x	0	0	1	1
UTC hours (h)	12	res	res	res	h ₅	h ₄	h ₃	h ₂	h ₁
UTC minute (min)	13	pid ₁₀	pid ₉	min ₆	min ₅	min ₄	min ₃	min ₂	min ₁
patch ID (pid)	14	pid ₈	pid ₇	pid ₆	pid ₅	pid ₄	pid ₃	pid ₂	pid ₁
baro/geo offset (bgo)	15	res	bgo ₇	bgo ₆	bgo ₅	bgo ₄	bgo ₃	bgo ₂	bgo ₁
slot (slt)	16	slt ₈	slt ₇	slt ₆	slt ₅	slt ₄	slt ₃	slt ₂	slt ₁
4-bit longitude offset (lon4), 4-bit latitude offset (lat4)	17	lon4 ₄	lon4 ₃	lon4 ₂	lon4 ₁	lat4 ₄	lat4 ₃	lat4 ₂	lat4 ₁
UTC second (sec)	18	sec ₆	sec ₅	sec ₄	sec ₃	sec ₂	sec ₁		

NOTE 1: "res" denotes currently unused.

NOTE 2: "x" denotes part of fixed data field.

Table 5.6: Information field 4 hex - UTC time

Description	Octet	Bit number							
		8	7	6	5	4	3	2	1
information field ID	11	X	x	x	x	0	1	0	0
UTC day (day)	12	res	res	res	day ₅	day ₄	day ₃	day ₂	day ₁
UTC year (yr)	13	yr ₈	yr ₇	yr ₆	yr ₅	yr ₄	yr ₃	yr ₂	yr ₁
UTC hours (h), UTC month (mon)	14	h ₄	h ₃	h ₂	h ₁	mon ₄	mon ₃	mon ₂	mon ₁
UTC minute (min)	15	res	h ₅	min ₆	min ₅	min ₄	min ₃	min ₂	min ₁
slot (slt)	16	slt ₈	slt ₇	slt ₆	slt ₅	slt ₄	slt ₃	slt ₂	slt ₁
4-bit longitude offset (lon4), 4-bit latitude offset (lat4)	17	lon4 ₄	lon4 ₃	lon4 ₂	lon4 ₁	lat4 ₄	lat4 ₃	lat4 ₂	lat4 ₁
UTC second (sec)	18	sec ₆	sec ₅	sec ₄	sec ₃	sec ₂	sec ₁		

NOTE: "res" denotes currently unused. "x" denotes part of fixed data field.

Table 5.7: Information field 8 hex - Two slot TCP/SVQ

Description	Octet	Bit number							
		8	7	6	5	4	3	2	1
information field ID	11	x	x	x	x	1	0	0	0
TCP									
latitude (lat)	12	lat ₈	lat ₇	lat ₆	lat ₅	lat ₄	lat ₃	lat ₂	lat ₁
	13	balt ₁₂	balt ₁₁	balt ₁₀	balt ₉	lat ₁₂	lat ₁₁	lat ₁₀	lat ₉
base altitude (balt)	14	balt ₈	balt ₇	balt ₆	balt ₅	balt ₄	balt ₃	balt ₂	balt ₁
longitude (lon)	15	lon ₈	lon ₇	lon ₆	lon ₅	lon ₄	lon ₃	lon ₂	lon ₁
	16	ttg ₆	ttg ₅	lon ₁₄	lon ₁₃	lon ₁₂	lon ₁₁	lon ₁₀	lon ₉
time to go (ttg)	17	ttg ₄	ttg ₃	ttg ₂	ttg ₁	res	res	res	res
TCP+1									
latitude (lat)	18	lat ₈	lat ₇	lat ₆	lat ₅	lat ₄	lat ₃	lat ₂	lat ₁
	19	balt ₁₂	balt ₁₁	balt ₁₀	balt ₉	lat ₁₂	lat ₁₁	lat ₁₀	lat ₉
base altitude (balt)	20	balt ₈	balt ₇	balt ₆	balt ₅	balt ₄	balt ₃	balt ₂	balt ₁
longitude (lon)	21	lon ₈	lon ₇	lon ₆	lon ₅	lon ₄	lon ₃	lon ₂	lon ₁
	22	ttg ₆	ttg ₅	lon ₁₄	lon ₁₃	lon ₁₂	lon ₁₁	lon ₁₀	lon ₉
time to go (ttg)	23	ttg ₄	ttg ₃	ttg ₂	ttg ₁	res	res	res	res
TCP+2									
latitude (lat)	24	lat ₈	lat ₇	lat ₆	lat ₅	lat ₄	lat ₃	lat ₂	lat ₁
	25	balt ₁₂	balt ₁₁	balt ₁₀	balt ₉	lat ₁₂	lat ₁₁	lat ₁₀	lat ₉
base altitude (balt)	26	balt ₈	balt ₇	balt ₆	balt ₅	balt ₄	balt ₃	balt ₂	balt ₁
longitude (lon)	27	lon ₈	lon ₇	lon ₆	lon ₅	lon ₄	lon ₃	lon ₂	lon ₁
	28	ttg ₆	ttg ₅	lon ₁₄	lon ₁₃	lon ₁₂	lon ₁₁	lon ₁₀	lon ₉
time to go (ttg)	29	ttg ₄	ttg ₃	ttg ₂	ttg ₁	res	res	res	res
TCP+3									
latitude (lat)	30	lat ₈	lat ₇	lat ₆	lat ₅	lat ₄	lat ₃	lat ₂	lat ₁
	31	balt ₁₂	balt ₁₁	balt ₁₀	balt ₉	lat ₁₂	lat ₁₁	lat ₁₀	lat ₉
base altitude (balt)	32	balt ₈	balt ₇	balt ₆	balt ₅	balt ₄	balt ₃	balt ₂	balt ₁
longitude (lon)	33	lon ₈	lon ₇	lon ₆	lon ₅	lon ₄	lon ₃	lon ₂	lon ₁
	34	ttg ₆	ttg ₅	lon ₁₄	lon ₁₃	lon ₁₂	lon ₁₁	lon ₁₀	lon ₉
time to go (ttg)	35	ttg ₄	ttg ₃	ttg ₂	ttg ₁	res	res	res	res
call sign left (csl)	36	csl ₈	csl ₇	csl ₆	csl ₅	csl ₄	csl ₃	csl ₂	csl ₁
	37	csl ₁₆	csl ₁₅	csl ₁₄	csl ₁₃	csl ₁₂	csl ₁₁	csl ₁₀	csl ₉
status (st)	38	st ₃	st ₂	st ₁	csl ₂₁	csl ₂₀	csl ₁₉	csl ₁₈	csl ₁₇
call sign right (csr)	39	csr ₈	csr ₇	csr ₆	csr ₅	csr ₄	csr ₃	csr ₂	csr ₁
	40	csr ₁₆	csr ₁₅	csr ₁₄	csr ₁₃	csr ₁₂	csr ₁₁	csr ₁₀	csr ₉
SVQ NAC, (nacv)	41	nacv ₃	nacv ₂	nacv ₁	csr ₂₁	csr ₂₀	csr ₁₉	csr ₁₈	csr ₁₇
Resolution Advisory active flag (ra), ACAS operational flag (acas), NIC _{baro} (nicb), CDTI display capability (cdti), NAC _n (naccp)	42	naccp ₄	naccp ₃	naccp ₂	naccp ₁	cdti	nicb	acas	ra
current patch ID (pid)	43	pid ₈	pid ₇	pid ₆	pid ₅	pid ₄	pid ₃	pid ₂	pid ₁
6-bit latitude offset (lat6)	44	pid ₁₀	pid ₉	lat ₆ ₆	lat ₆ ₅	lat ₆ ₄	lat ₆ ₃	lat ₆ ₂	lat ₆ ₁
6-bit longitude offset (lon6)	45	altr ₉	br/gr	lon ₆ ₆	lon ₆ ₅	lon ₆ ₄	lon ₆ ₃	lon ₆ ₂	lon ₆ ₁
baro rate/geo rate (br/gr)									
altitude rate (altr)	46	altr ₈	altr ₇	altr ₆	altr ₅	altr ₄	altr ₃	altr ₂	altr ₁

Description	Octet	Bit number							
		8	7	6	5	4	3	2	1
aircraft category (ac) SIL (sil)	47	res	sil ₂	sil ₁	ac ₅	ac ₄	ac ₃	ac ₂	ac ₁
ground speed (gs)	48	gs ₈	gs ₇	gs ₆	gs ₅	gs ₄	gs ₃	gs ₂	gs ₁
ground track (gt)	49	gs ₁₁	gs ₁₀	gs ₉	gt ₅	gt ₄	gt ₃	gt ₂	gt ₁
	50	gt ₁₁	gt ₁₀	gt ₉	gt ₈	gt ₇	gt ₆		

NOTE 1: "x" denotes part of fixed data field; "res" denotes currently unused.
NOTE 2: This burst definition allows a further octet of payload to complete the two slots.
NOTE 3: The detailed definition of the TCP information fields and their operational usage is still under discussion in the aviation community. As a consequence, the TCP format definition described above may be subject to future revision.

Table 5.8: Information field 9 hex - Single slot TCP

Description	Octet	Bit number							
		8	7	6	5	4	3	2	1
information field ID	11	x	x	x	x	1	0	0	1
base altitude (balt)	12	balt ₈	balt ₇	balt ₆	balt ₅	balt ₄	balt ₃	balt ₂	balt ₁
TCP number (no)	13	balt ₁₂	balt ₁₁	balt ₁₀	balt ₉	no ₂	no ₁	pid ₁₀	pid ₉
patch ID (pid)	14	pid ₈	pid ₇	pid ₆	pid ₅	pid ₄	pid ₃	pid ₂	pid ₁
latitude (lat)	15	lat ₈	lat ₇	lat ₆	lat ₅	lat ₄	lat ₃	lat ₂	lat ₁
longitude (lon)	16	lat ₁₂	lat ₁₁	lat ₁₀	lat ₉	lon ₁₄	lon ₁₃	lon ₁₂	lon ₁₁
	17	lon ₁₀	lon ₉	lon ₈	lon ₇	lon ₆	lon ₅	lon ₄	lon ₃
time to go (ttg)	18	ttg ₆	ttg ₅	ttg ₄	ttg ₃	ttg ₂	ttg ₁		

NOTE: "x" denotes part of fixed data field.

Table 5.9: Information field 5 hex - Single Slot SVQ

Description	Octet	Bit number							
		8	7	6	5	4	3	2	1
information field ID	11	x	x	x	x	0	1	0	1
NAC _p	12	0	0	0	1	nacp ₄	nacp ₃	nacp ₂	nacp ₁
NAC _v (nacv), SIL (sil), NIC _{baro} (nicb), ACAS operational flag (acas), Resolution Advisory active flag (ra)	13	nacv ₃	nacv ₂	nacv ₁	sil ₂	sil ₁	nicb	acas	ra
status (st) and aircraft category (ac)	14	st ₃	st ₂	st ₁	ac ₅	ac ₄	ac ₃	ac ₂	ac ₁
Reserved for future definition	15	res	res	res	res	res	res	res	res
Reserved for future definition	16	res	res	res	res	res	res	res	res
Reserved for future definition	17	res	res	res	res	res	res	res	res
Reserved for future definition	18	res	res	res	res	res	res		

NOTE 1: "x" denotes part of fixed data field.
NOTE 2: "res" denotes currently unused.
NOTE 3: The detailed definition of the SVQ information fields and their operational usage is still under discussion in the aviation community. As a consequence, the SVQ format definition described above may be subject to future revision. Currently there is a discussion in the aviation community to provide further information such as describing the ADS-B position reference point, the length and width, the capability classes (e.g. information for TCAS/ACAS, CDTI etc) and the operational mode codes (receiving ATC services, etc). There are spare octets to provide this information, when agreed in the future, but at this stage they are left unassigned to facilitate the future assignment.

Table 5.10: Information field A1 hex - Aircraft data

Description	Octet	Bit number							
		8	7	6	5	4	3	2	1
information field ID	11	x	x	x	x	1	0	1	0
aircraft category (ac)	12	0	0	0	1	ac ₄	ac ₃	ac ₂	ac ₁
status (st)	13	ac ₅	st ₃	st ₂	st ₁	csl ₁₂	csl ₁₁	csl ₁₀	csl ₉
call sign left (csl)	14	csl ₈	csl ₇	csl ₆	csl ₅	csl ₄	csl ₃	csl ₂	csl ₁
	15	csl ₂₀	csl ₁₉	csl ₁₈	csl ₁₇	csl ₁₆	csl ₁₅	csl ₁₄	csl ₁₃
call sign right (csr)	16	csr ₂₁	csr ₇	csr ₆	csr ₅	csr ₄	csr ₃	csr ₂	csr ₁
	17	csr ₁₅	csr ₁₄	csr ₁₃	csr ₁₂	csr ₁₁	csr ₁₀	csr ₉	csr ₈
	18	csr ₂₁	csr ₂₀	csr ₁₉	csr ₁₈	csr ₁₇	csr ₁₆		

NOTE: "x" denotes part of fixed data field.

Table 5.11: Information field AA0 hex - High resolution

Description	Octet	Bit number							
		8	7	6	5	4	3	2	1
information field ID	11	x	x	x	x	1	0	1	0
	12	1	0	1	0	0	0	0	0
Surveillance Integrity Level (sil)	13	res	res	sil ₂	sil ₁	gs ₁₂	gs ₁₁	gs ₁₀	gs ₉
ground speed (gs)	14	gs ₈	gs ₇	gs ₆	gs ₅	gs ₄	gs ₃	gs ₂	gs ₁
8-bit longitude offset (lon8)	15	lon8 ₈	lon8 ₇	lon8 ₆	lon8 ₅	lon8 ₄	lon8 ₃	lon8 ₂	lon8 ₁
8-bit latitude offset (lat8)	16	lat8 ₈	lat8 ₇	lat8 ₆	lat8 ₅	lat8 ₄	lat8 ₃	lat8 ₂	lat8 ₁
ground track (gt)	17	gt ₈	gt ₇	gt ₆	gt ₅	gt ₄	gt ₃	gt ₂	gt ₁
turn indication (tind)	18	gt ₁₂	gt ₁₁	gt ₁₀	gt ₉	tind ₂	tind ₁		

NOTE 1: "x" denotes part of fixed data field.
NOTE 2: "res" refers to bits available for the information field.

Requirement reference	
5.1.1.3	The values of the information field subfields shall be as defined in table 5.12.

Table 5.12: Information field encoding (variable data field)

Subfield	Range	Encoding	Notes
Surveillance Integrity Level SIL (sil)	0 - 3	Values 0, 1, 2, 3 in accordance with the four SIL categories specified for ADS-B MASPS by RTCA DO-242A [3] clause 2.1.2.15.	
Position Navigation Accuracy Category NAC_p (nacp)	0 - 11	Values 0 through 11 in accordance with the twelve NAC_p categories specified for ADS-B MASPS by RTCA DO-242A [3] clause 2.1.2.13.	
Velocity Navigation Accuracy Category NAC_v (nacv)	0 - 4	Values 0, 1, 2, 3, 4 in accordance with the five NAC_v categories specified for ADS-B MASPS by RTCA DO-242A [3] clause 2.1.2.14.	
NIC_{baro} (nicb)	Binary	0 = Barometric pressure altitude has not been cross checked against another source of pressure altitude. 1 = There is more than one source of barometric pressure altitude data and cross checking of one source against another has been performed.	
4-bit latitude (lat4)	-	A high-resolution component to enhance the 12-bit low-resolution encoding transmitted in the fixed part (see [5] clause 5.4.2.3). Encoding of this high-resolution component is described in clause 5.1.6.	
6-bit latitude (lat6)	-	See encoding for lat4.	
8-bit latitude (lat8)	-	See encoding for lat4.	
4-bit longitude (lon4)	-	A high-resolution component to enhance the 14-bit low-resolution encoding transmitted in the fixed part (see [5] clause 5.4.2.3). Encoding of this high-resolution component is described in clause 5.1.6.	
6-bit longitude (lon6)	-	See encoding for lon4.	
8-bit longitude (lon8)	-	See encoding for lon4.	
baro/geo offset (bgo)	0 - 127	bgo = barometric - geometric altitude Encoding as in table 5.13.	
baro rate/geo rate (br/gr)	Binary	0 = altitude rate is barometric altitude rate. 1 = altitude rate is geometric altitude rate.	
altitude rate (altr)	-32 100 fpm to +32 100 fpm	Bit $altr_g$ encodes the sign of altitude rate of change with 0 = climb and 1 = descend. $altr_g$ shall be set to 0 if the magnitude of altitude rate is unknown Bits $altr_8 \dots altr_1$ encode the magnitude of altitude rate of change as specified in table 5.15.	
ground speed (gs)	0 to \geq 11 256 knots	Encoding as in table 5.14.	Range is 0 to 3 069 knots for 11 bits and 0 to 11 256 for 12 bits. Resolution steps from 1 knot to 4 knots. Note that bit 12 is only available in the high dynamic variable part.
ground track (gt)	0° to 359,912°	due North $\pm \frac{1}{2}N+1$ degrees coded as 0 and decoded as due North. Resolution is $360/2^N$ degrees.	Ground track is the same as true track. N is the number of bits (either 11 or 12) assigned in the variable field for ground track.
turn indication (tind)	0 - 3	0 = Unknown, 1 = Left, 2 = Right and 3 = Straight	The threshold between straight and turning is an operational issue that will be specified elsewhere.
patch ID (pid)	-	Encoding is described in clause 5.1.6.4.	
UTC year (yr)	1 - 255	current year = 1970, 0 = N/A.	
UTC month (mon)	1 - 12	integer months.	
UTC day (day)	1 - 31	integer days, 00= N/A.	

Subfield	Range	Encoding	Notes
UTC hours (h)	0 - 23	integer hours.	
UTC minute (min)	0 to 59	integer minutes.	
UTC second (sec)	0 to 60	integer seconds.	Seconds run up to 60 to allow for leap seconds.
slot (slt)	0 to 255	integer slots, 0 indicates the first slot in the second frame.	
TCP number (no)	0 - 3	0 = current 1 = next 2 = next + 1 3 = next + 2	
TCP time to go (ttg)	0 - 63	Indicates the time to reach the indicated TCP from either the current position (no = 0) or from the previous TCP (no = 1, 2 or 3). Encoding as in table 5.18.	
call sign left (csl), call sign right (csr)		Encoding for call sign: 1) Call sign shall be left justified. 2) Only valid characters are A-Z, 0 - 9 and null: Assign A- Z = 0 - 25, 0 - 9 = 26 - 35, null = 36. 3) Call sign shall be an eight character string "c ₁ , c ₂ , c ₃ , c ₄ , c ₅ , c ₆ , c ₇ , c ₈ ". 4) $csl = c_1 37^3 + c_2 37^2 + c_3 37 + c_4$. 5) $csr = c_5 37^3 + c_6 37^2 + c_7 37 + c_8$.	
aircraft category (ac)	0 - 31	Encoding as in table 5.16.	
status (st)	0 - 7	Encoding as in table 5.17.	
CDTI flag (cdti)	Binary	0 = not CDTI equipped. 1 = CDTI equipment installed and operational.	

Requirement reference	
5.1.1.4	For TCP transmission, position encoding shall use the Patch ID encoding described in clause 5.1.6.4.
5.1.1.5	For transmission of the single slot TCP variable part (information field 9 hex), bits 1 and 2 of the longitude subfield shall not be sent.
5.1.1.6	On receipt of a single slot TCP variable part, the value of bits 1 and 2 shall be assumed to be equal to 0.
5.1.1.7	The encoding of the baro/geo offset (bgo) subfield shall be as defined in table 5.13.
NOTE:	The longitude (lon) subfield is truncated by two bits. This means that the available resolution will be ±150 m, except at high latitudes where the resolution will decrease to ±450 m.

Table 5.13: Baro/geo offset encoding (variable data field)

Barometric/geometric altitude offset of transmitting station (ft)		Transmitted value of bgo	Decoded offset (ft)	
base alt \leq 24 012,5	24 012,5 < base alt		base alt \leq 24 012,5	24 012,5 < base alt
bgo < -2 075	bgo < -5 050	1	< -2 075	< -5 050
-2 075 \leq bgo < -2 025	-5 050 \leq bgo < -4 950	2	-2 050	-5 000
-2 025 \leq bgo < -1 975	-4 950 \leq bgo < -4 850	3	-2 000	-4 900
-1 975 \leq bgo < -1 925	-4 850 \leq bgo < -4 750	4	-1 950	-4 800
-1 925 \leq bgo < -1 875	-4 750 \leq bgo < -4 650	5	-1 900	-4 700
-1 875 \leq bgo < -1 825	-4 650 \leq bgo < -4 550	6	-1 850	-4 600
↓	↓	↓	↓	↓
3 975 \leq bgo < 4 025	7 050 \leq bgo < 7 150	123	4 000	7 100
4 025 \leq bgo < 4 075	7 150 \leq bgo < 7 250	124	4 050	7 200
4 075 \leq bgo < 4 125	7 250 \leq bgo < 7 350	125	4 100	7 300
bgo \geq 4 125	bgo \geq 7 350	126	> 4 125	> 7 350
reserved		127	error	
offset unknown		0	offset unknown	

Requirement reference	
5.1.1.8	The encoding of the ground speed (gs) subfield shall be as defined in table 5.14.

Table 5.14: Ground speed encoding (variable data field)

Actual speed over ground of transmitting station (knots)	Transmitted value of gs (decimal equivalent of field)	Decoded speed over ground (knots)
unknown	0	unknown
0 \leq speed < 0,5	1	0
0,5 \leq speed < 1,5	2	1
1,5 \leq speed < 2,5	3	2
2,5 \leq speed < 3,5	4	3
3,5 \leq speed < 4,5	5	4
↓	↓	↓
10 215 \leq speed < 1 022,5	1 023	1 022
10 225 \leq speed < 1 024	1 024	1 023
1 024 \leq speed < 1 026	1 025	1 025
1 026 \leq speed < 1 028	1 026	1 027
↓	↓	↓
3 068 \leq speed < 3 070	2 047	3 069
3 070 \leq speed < 3 074	2 048	3 072
3 074 \leq speed < 3 078	2 049	3 076
3 078 \leq speed < 3 082	2 050	3 080
↓	↓	↓
11 250 \leq speed < 11 254	4 093	11 252
11 254 \leq speed < 11 258	4 094	11 256
11 258 \leq speed	4 095	more than or equal to 11 258

NOTE: The time over which the ground speed is computed is station-dependent.

Requirement reference	
5.1.1.9	The encoding of the magnitude part of the altitude rate (altr) subfield (bits 1 to 8) shall be as defined in table 5.15.

NOTE: The quantization step size of altitude rate (100 fpm) is equivalent to one sigma error of 0,5 fps.

Table 5.15: Altitude rate magnitude encoding and decoding

Actual altitude rate of transmitting station (fpm)	Transmitted decimal value of $altr_8 \dots altr_1$	Decoded magnitude of altitude rate (fpm)
unknown	0	unknown
$ arate < 50$	1	0
$50 \leq arate < 150$	2	100
$150 \leq arate < 250$	3	200
$250 \leq arate < 350$	4	300
↓	↓	↓
$19\ 950 \leq arate < 20\ 050$	201	20 000
$20\ 050 \leq arate < 20\ 300$	202	20 200
$20\ 300 \leq arate < 20\ 500$	203	20 400
↓	↓	↓
$29\ 900 \leq arate < 30\ 100$	251	30 000
$30\ 100 \leq arate < 30\ 500$	252	30 250
$30\ 500 \leq arate < 31\ 000$	253	30 750
$31\ 000 \leq arate < 32\ 000$	254	31 500
$32\ 000 \leq arate $	255	more than or equal to 32 000

Requirement reference	
5.1.1.10	The encoding of the aircraft category (ac) subfield shall be as defined in table 5.16.

Table 5.16: Aircraft category encoding

Encoded value	Aircraft/vehicle category	Comments
0	light a/c	7 000 kg (15 500 lbs) or less
1	reserved	
2	medium a/c	more than 7 000 kg (15 500 lbs) and less than 136 000 kg (300 000 lbs)
3	reserved	
4	heavy a/c	136 000 kg (300 000 lbs) or more
5	highly manoeuvrable and high speed	> 5 g acceleration capability and > 400 knots
6, 7, 8	reserved	
9	rotorcraft	
10	glider/sailplane	
11	lighter than air	
12	unmanned aerial vehicle	
13	space/transatmospheric vehicle	
14	ultra-light/hang-glider/para-glider	
15	parachutist/skydiver	
16, 17, 18	reserved	
19	surface vehicle - emergency vehicle	
20	surface vehicle - service vehicle	
21	fixed ground or tethered obstruction	
22, 23	reserved	
24, 25, 26, 27, 28, 29, 30	reserved	
31	unknown	

Requirement reference	
5.1.1.11	The encoding of the aircraft status (st) subfield shall be as defined in table 5.17.

Table 5.17: Aircraft status (emergency/priority status) encoding

Encoded value	Status
0	no emergency/not reported
1	general emergency
2	lifeguard/medical
3	minimal fuel
4	no communications
5	unlawful interference
6, 7	reserved

Requirement reference	
5.1.1.12	The encoding of the time to go (ttg) subfield shall be as defined in table 5.18.

Table 5.18: Time to go subfield encoding

Actual time to go (minutes)	Transmitted decimal value of ttg	Decoded magnitude of time to go (minutes)
unknown	0	No time to go information available
time to go < 0,125	1	0
$0,125 \leq \text{time to go} < 0,375$	2	0,25
$0,375 \leq \text{time to go} < 0,625$	3	0,5
↓	↓	↓
$15,125 \leq \text{time to go} < 15,375$	62	15,25
$15,375 \leq \text{time to go}$	63	more than or equal to 15,375

Requirement reference	
	Use of information fields
5.1.1.13	Information fields 3 hex and 4 hex shall only be transmitted by ground stations.
5.1.1.14	Information fields 0 hex, 1 hex, 2 hex, 8 hex, 9 hex, 5 hex, A1 hex, and AA0 hex shall not be transmitted by ground stations.

5.1.2 ADS-B Request

5.1.2.1 ADS-B request format

Requirement reference	
5.1.2.1.1	To request that a station transmit an ADS-B report consisting of a synchronization burst a station shall transmit a general request burst with $r\text{-mi}_1 = 0$.
5.1.2.1.2	To request that a station transmit an ADS-B report consisting of a synchronization burst a station shall include the auxiliary information as shown in tables 5.19, 5.20 and 5.21, as appropriate given the values of the sleep and auto bits in octet 5.
5.1.2.1.3	The information subfields shall be encoded according to table 5.22.
5.1.2.1.4	Parameter blocks shall be included only if the respective parameter flag bit is 1.
5.1.2.1.5	Parameter blocks shall be included in the order (most significant to least significant) of the parameter flag bits.
	Recommendation
5.1.2.1.6	A ground station should use the channel management command in preference to an ADS-B request.

5.1.2.2 Sleep Mode

Requirement reference	
5.1.2.2.1	If the requesting station desires the responding station to respond at one specified rate as a default, but a different specified rate in the event certain position or velocity deviation thresholds are exceeded, the requesting station shall set the sleep bit equal to 1 and octets 6 - 7 in table 5.20 shall be sent.
5.1.2.2.2	Otherwise, the sleep bit shall be set = 0 and octets 6 - 7 in table 5.20 shall not be sent.
NOTE:	The default reporting rate is defined by the reservation data. The contingency reporting rate, in the event that certain position or velocity deviation thresholds are exceeded, is defined by the secondary reporting rate (snr) field.

5.1.2.3 Automatic Selection of Variable Information Fields

Requirement reference	
5.1.2.3.1	If the requesting station desires the responding station to respond with synchronization burst variable parts selected autonomously by the responding station, the requesting station shall set the auto bit = 0 and octet k in table 5.21 shall not be sent.
5.1.2.3.2	Otherwise, the station shall set the auto bit = 1 and the desired variable part ID shall be encoded as indicated in table 5.21.
NOTE 1:	The value of k = 6 if the autonomous monitoring (sleep) bit = 0 (implying that the auxiliary information for sleep mode is not transmitted), and k = 8 if the sleep bit = 1.
NOTE 2:	The requested information ID (r-id) field, which is of variable length, should be encoded in the minimum length allowed. Then, for r-id selections supported within 4 bits, the parameter set enabled by the autonomous information (auto) bit fits in a single octet while the overall ADS-B request (with the autonomous monitoring (sleep) parameters and requested variable part identification) fits in a single-slot message of length = 19 octets.
NOTE 3:	As an example, an ADS-B request for an aircraft off the airport movement area, which is stopped, could potentially be sent with the encoding of table 5.22a. This encoding imposes sleep mode with wake up parameters, i.e. maximum sleep velocity (vel) = 4 knots and maximum sleep position (pos) = 10 m, and requests the high resolution variable part. The secondary reporting rate (snr) field indicates that the station should transmit once every second in the event that the velocity or position deviation thresholds are exceeded.

Table 5.19: ADS-B request bit encoding

Description	Octet	Bit number							
		8	7	6	5	4	3	2	1
burst ID autonomous monitoring (sleep), autonomous information (auto), requested base altitude (r-b/a)	5	sleep	auto	r-b/a ₂	r-b/a ₁	0	0	0	1
	6 to m	See tables 5.20 and 5.21							

Table 5.20: ADS-B request bit encoding for sleep mode parameters when sleep bit = 1

Description	Octet	Bit number							
		8	7	6	5	4	3	2	1
secondary reporting rate (snr), maximum sleep velocity (vel)	6	snr ₄	snr ₃	snr ₂	snr ₁	vel ₄	vel ₃	vel ₂	vel ₁
maximum sleep position (pos)	7	pos ₈	pos ₇	pos ₆	pos ₅	pos ₄	pos ₃	pos ₂	pos ₁

Table 5.21: ADS-B request bit encoding for auto parameters when auto bit = 1

Description	Octet	Bit number							
		8	7	6	5	4	3	2	1
length (lg), auxiliary data (aux), requested information field ID (r-id) (see note)	k	lg ₂	lg ₁	aux ₂	aux ₁	r-id ₄	r-id ₃	r-id ₂	r-id ₁
NOTE: The r-id field may continue into additional octets depending on the variable part requested.									

Table 5.22: ADS-B request field encoding

Subfield	Range	Encoding	Out of Scale	Notes
sleep	Boolean	0 = no sleep mode; 1 = sleep mode	n/a	if 1, additional information describing sleep mode parameters is provided as a first additional information subfield starting in octet 6.
autonomous information (auto)	Boolean	0 = autonomously select transmitted information field 1 = provide requested information field only	n/a	if 1, additional information describing requested information is provided as an additional information subfield starting in octet 6 (if sleep = 0 implying lack of sleep mode parameters), or octet 8 (if sleep = 1).
requested information ID (r-id)	Binary; variable length	see table 5.2	A value not contained in table 5.2	Requests the information field identity contained in the variable data field.
maximum sleep velocity (vel)	1 to 15 knots	integer knots	0= ignore	
maximum sleep position (pos)	1 to 255 metres	integer metres	0= ignore	
secondary reporting rate (snr)	same as nr	see [5], table 5.28	n/a	
parameter group length (lg)	0 - 3	Binary	n/a	Indicates number of additional octets in parameter block (e.g. a parameter block comprising a single octet is encoded as 0).
auxiliary parameters (aux)	0 - 3	If r-id = 0 or 1 hex, then: 00 = baro rate; 01 = geo rate 10 = reserved 11 = do not care. If r-id = 9 _{hex} , then: 00 = current TCP; 01 = next TCP, 10 = next + 1 TCP, 11 = next + 2 TCP. If r-id = 2, 3, 4, 8, A1, or AA0 hex then: aux = 00 on transmit and ignored on receipt		Interpretation depends on value of r-id field. Unassigned values are reserved.
requested base altitude (r-b/a)	0 - 3	See [5], table 5.76		

Table 5.22a: Example of ADS-B request bit encoding for sleep mode with request for high precision variable part

Description	Octet	Bit number							
		8	7	6	5	4	3	2	1
requested message ID (r-mi ¹) (bit 4 = 0), burst ID, Autonomous monitoring (sleep), Autonomous information (auto), requested base altitude (r-b/a)	5	sleep (1)	auto (1)	r-b/a ²	r-b/a ¹	0	0	0	1
secondary reporting rate (snr), maximum sleep velocity (vel)	6	snr ⁴ (1)	snr ³ (1)	snr ² (0)	snr ¹ (1)	vel ⁴ (0)	vel ³ (1)	vel ² (0)	vel ¹ (0)
maximum sleep position (pos)	7	pos ⁸ (0)	pos ⁷ (0)	pos ⁶ (0)	pos ⁵ (0)	pos ⁴ (1)	pos ³ (0)	pos ² (1)	pos ¹ (0)
requested information field ID (r-id)	8	lg ² (0)	lg ¹ (0)	aux ² (0)	aux ¹ (0)	r-id ⁴ (1)	r-id ³ (0)	r-id ² (1)	r-id ¹ (0)

5.1.3 Default ADS-B Reporting

Requirement reference	
5.1.3.1	In the absence of an ADS-B request from a peer station or a request from the ADS-B application in the station, the station shall transmit at least 12 synchronization bursts per minute averaged over the two GSCs.
Recommendation	
5.1.3.2	A station should aim to distribute its transmissions evenly between the two GSCs.

5.1.4 ADS-B Procedures

Requirement reference	
ADS-B request procedures	
5.1.4.1	A station issuing an ADS-B request shall set the auto bit to 1 and include the r-id field when requesting a specific information field.
5.1.4.2	The requesting station shall set the auto bit to 0 and not include the r-id field when it desires that the responding unit determine which information field is the most important at any point in time.
5.1.4.3	The requesting station shall set the sleep bit to 0 when requesting a single response (e.g. via a unicast request reservation).
5.1.4.4	The requesting station shall set the sleep bit to 1 and include position and velocity thresholds when it wants the responding station to transmit a synchronization burst in directed slots at one rate, but transmit at a higher rate under certain circumstances (see note).
Transmission of time synchronization request	
5.1.4.5	A station requesting the UTC time synchronization information field (information field ID 24) shall only transmit a request to a station that has announced that it is operating with a primary time source (tfom = 0 or 1).
Information field priority	
5.1.4.6	When a station is requested to transmit a series of sync bursts with different variable part content, information fields 0, 1, 2, 3, 4 and A1 hex shall have priority over other information fields.
TCP/SVQ change procedures	
5.1.4.7	When a mobile has set its TCP/SVQ change flag to 0, only ground stations shall be allowed to respond by issuing an ADS-B request burst requesting that the mobile transmit a synchronization burst containing the two slot TCP/SVQ variable part.
NOTE:	The procedures for sleep mode apply to vertical as well as horizontal movement.

5.1.5 CTRL Parameters

5.1.5.1 Directory of Service (DOS) message

Requirement reference	
5.1.5.1.1	Directory of service information shall be transmitted by a ground station only using the CTRL DOS parameter defined in [5], clauses 5.4.3.4.2 to 5.4.3.4.12.
5.1.5.1.2	The application fields shall be encoded as defined in table 5.23.

Table 5.23: Encoding of application fields

Encoding (decimal equivalent)	Implied meaning
0	ADS-B
1	TIS-B
2	Secondary navigation capability
3	FIS-B
4	GNS-B

Requirement reference	
5.1.5.1.3	The service information (si) field for service information type (sit) field equal to hex 00 shall be as defined in table 5.24.

Table 5.24: Encoding of service information field for sit = hex 00

Service information (si) field bit number	Service	Equivalent application field (see table 5.23)
1	ADS-B	0
2	TIS-B	1
3	Secondary navigation capability	2
4	FIS-B	3
5	GNS-B	4
6 - 8	reserved	

5.1.5.2 Channel Management Parameter

Requirement reference	
5.1.5.2.1	The channel management parameter shall have a parameter ID equal to C6h.
5.1.5.2.2	If the channel management parameter is included within a UCTRL DLPDU with the ucid subfield set to 2, the channel management parameter ID and parameter length shall be omitted and no other parameter included in the UCTRL_DLPDU.
5.1.5.2.3	The channel management parameter shall be divided into component blocks as described in table 5.25.
5.1.5.2.4	If present, each component block shall appear in the channel management parameter in the order shown in table 5.25.

Table 5.25: Component blocks of channel management parameter

Blocks	Description
Header block	Contains the CTRL header and the non-repetitive information for each of the sub-elements.
Destination block	Contains a list of zero or more destinations or a geographic region, along with the timeout and slot offset from the current slot to the start of the script (zero destinations included implies broadcast).
Transmission definition block	Contains from 0 to 15 transmission definitions in an unordered list. Each definition describes a particular desired transmission (one not already specified in SARPs) and all relevant options. The location of a particular transmission block in this list defines an implicit pointer used in the script block (i.e. thereby specifying a particular message).
Frequency block	Contains from 1 to 7 frequencies in an ordered list and optional sleep parameters to use on each frequency. The location of a particular frequency block in this list defines an implicit pointer used in the script block (i.e. thereby specifying a particular frequency).
Parameter block	Contains QoS and other transmission parameters to use with the elements of this script.
Script block	Contains a repeat rate and from 1 to N script elements in an ordered list. Each script element consists of an optional repeat count, a frequency block pointer, and a transmission block pointer.

Requirement reference	
	Header block encoding
5.1.5.2.5	The channel management parameter header block shall appear first in the channel management parameter and be encoded as defined in table 5.26 with subfield encodings as defined in table 5.27.

Table 5.26: Header block bit encoding

Description	Octet	Bit number							
		8	7	6	5	4	3	2	1
directed timeout (dt)	m+2	dt ₄	dt ₃	dt ₂	dt ₁	do ₁₂	do ₁₁	do ₁₀	do ₉
directed offset (do)	m+3	do ₈	do ₇	do ₆	do ₅	do ₄	do ₃	do ₂	do ₁
destination count (dc)	m+4	dc ₈	dc ₇	dc ₆	dc ₅	dc ₄	dc ₃	dc ₂	dc ₁
command set ID (csid), transmission definition count (tc)	m+5	csid ₄	csid ₃	csid ₂	csid ₁	tc ₄	tc ₃	tc ₂	tc ₁
frequency count (fc), script duration type (styp), script rate (sr)	m+6	fc ₃	fc ₂	fc ₁	styp	sr ₄	sr ₃	sr ₂	sr ₁
transmit parameter count (pc)	m+7	res	res	pc ₆	pc ₅	pc ₄	pc ₃	pc ₂	pc ₁
script count (sc)	m+8	sc ₈	sc ₇	sc ₆	sc ₅	sc ₄	sc ₃	sc ₂	sc ₁

Table 5.27: Header block field encoding

Subfield	Encoding	Notes
directed timeout (dt)	See [5], table 5.30.	
directed offset (do)	See [5], table 5.30.	
destination count (dc)	0: destination block absent (see clause 5.1.5.2.9) 1 - 255 : number of octets in destination block	0 implies broadcast.
Command set ID (csid)	0 - 14 : valid csid identifiers 15 : cancel all prior commands	identifier specifying this command (see note).
transmission definition count (tc)	0 : transmission block absent 1 - 15 : number of elements in the transmission definition block	
frequency count (fc)	0 : no freq listed (csid = 15) 1 - 7 : number of frequencies	The number of elements in the frequency block.
script duration type (styp)	styp = 0: interpret sr as the number of times the entire script repeats per minute; styp = 1: interpret sr as the number of minutes until script repeats.	
script rate (sr)	0 - 15. Interpreted based on styp. For styp = 0, sr is encoded per nr in [5], table 5.28. For styp = 1, sr is encoded as minutes between 2 (encoded as 0) and 17 minutes.	
script count (sc)	1 (encoded as 0) - 256	Number of bytes in script block.
transmit parameter count (pc)	0 - 63	Number of bytes in the transmit parameter block.
<p>NOTE: The command set ID (csid) allows a ground station to uplink several (up to 15) separate commands to each aircraft or set of aircraft (including all aircraft in view) which are each processed separately. A transmission with csid = x overrides operations specified in a previous transmission with csid = x, but does not affect operations dictated by previous transmissions with csid not equal to x. Hence a ground station can command multiple sets of messages (each set containing various types of transmissions), and the transmissions can have different report periods from one set to another. An example is a sequence of sync bursts on two or more frequencies defined by command set csid = 0, and a separate sequence of TCPs on the same or different frequency(ies) defined by command set csid = 1. The use of different command sets allows directed-slot operation for both command sets even though the two sets of commanded transmissions may have different burst lengths (e.g. one slot for sync bursts and two slots for TCPs).</p>		

Requirement reference	
5.1.5.2.6	The number of elements in the script (total number of transmissions over one repeat cycle) shall be designated NES.
5.1.5.2.7	The number of transmissions per minute shall be designated NTM.
NOTE 1: A repeat cycle can be less than a submultiple of one minute, exactly one minute, or multiple minutes.	
NOTE 2: The definition of the script block is provided in clause 5.1.5.2.25ff. The script consists of one or more single octet fields each referring to a single transmission and one or more two octet fields each referring to one or more transmissions (as defined in the repeat count subfield). If there are n single octet fields, m double octet fields and, for each double octet field, a number of transmissions pm, then: NES = n + sum (m pm) and sc = n + 2 m.	
NOTE 3: The length of a single channel management parameter is limited to 255 octets because a single octet CTRL length field is used in the CTRL parameter format.	

Requirement reference	
	Destination block encoding
5.1.5.2.8	The destination block shall consist of zero destinations (a broadcast), one or more addressed destinations, or a regional definition, as defined in the following clauses.
	Broadcast destination
5.1.5.2.9	If the destination count (dc) in the header block is zero, then the channel management parameter shall apply to all stations.
	Addressed destination
5.1.5.2.10	If bit 8 of the first octet in the destination block is a zero, then the destination block shall consist of one or more addresses per table 5.28 with encoding defined in table 5.29.
NOTE 1: If the destination block is an implied broadcast (dc = 0 per table 5.27), it is considered to match the receiving station's ID.	
NOTE 2: Bit 8 of the first octet is used to indicate the start of the addressed destination block. If set to zero, the addressed destination block is present. If set to one a regional multicast block is present (see clause 5.1.5.2.11). Hence the individual offset for the first destination in the addressed destination block is limited to 0 to 15 and not 0 to 31.	

Table 5.28: Addressed destination block bit encoding

Description	Octet	Bit number							
		8	7	6	5	4	3	2	1
Individual offset (ido)	1	0	ido ₄	ido ₃	ido ₂	ido ₁	d ₂₇	d ₂₆	d ₂₅
destination address (d)	2	d ₂₄	d ₂₃	d ₂₂	d ₂₁	d ₂₀	d ₁₉	d ₁₈	d ₁₇
	3	d ₁₆	d ₁₅	d ₁₄	d ₁₃	d ₁₂	d ₁₁	d ₁₀	d ₉
	4	d ₈	d ₇	d ₆	d ₅	d ₄	d ₃	d ₂	d ₁

Table 5.29: Addressed destination block field encoding

Subfield	Encoding	Notes
Individual offset (ido)	0 - 15 for the first address in the addressed destination block 0 - 31 otherwise	See description of usage below.
destination address (d)	See [5], clause 5.3.1.2	

Requirement reference	
	Directed Rate Operations
5.1.5.2.11	A ground station shall set the individual offset (ido) equal to zero in the destination block with a mobile station's address if it desires that the addressed station operate in directed rate mode.
5.1.5.2.12	A ground station shall set the destination count (dc) equal to zero in the header block if it desires that all mobiles shall operate in directed rate mode.
	Directed Slot Operations
5.1.5.2.13	The transmitting station shall set the directed offset (do) not equal to zero, and set the individual offset (ido) not equal to zero in a destination block with the station's address, if it desires the addressed station to operate in directed slot mode.
5.1.5.2.14	The sum of the individual offset parameter ido for each addressed station and directed offset (do) subfield shall indicate the number of slots by which the transmissions of that station are to be offset from the first slot of the channel management command.
5.1.5.2.15	A station transmitting a channel management parameter for which the directed offset (do) is not equal to zero, and containing one or more addressed destination blocks for which the individual offset (ido) is not equal to zero, shall first ensure that the slots which will be used by addressed stations have first been reserved using block reservation protocols (see [5] clause 5.2.17) or ground quarantine (see [5], clause 5.2.3.2).
NOTE: Directed slot operation is announced by setting bit 1 of octet 1 of the transmitted burst = 1.	

Requirement reference	Regional multicast
5.1.5.2.16	The transmitting station shall set bit 8 of the first octet of the destination block to 1 and include the regional multicast block per table 5.30 with encoding defined in table 5.31 if it desires that all mobiles within the specified region transmit according to the channel management parameter.
5.1.5.2.17	<p>The following conditions shall determine whether the mobile is expected to act on the channel management command:</p> <p>The mobile will be considered to be in the defined region if Condition 1 is true and either Condition 2a or Condition 2b is true:</p> <p>Condition 1: altitude compliance</p> <ul style="list-style-type: none"> - the station altitude (using baro altitude if available, otherwise geo altitude) is greater than or equal to the lower altitude and less than or equal to the upper altitude. <p>Condition 2a: radial range compliance when there is at least one vertex k with radial k less than or equal to the station's radial from the centre of the defined region</p> <ul style="list-style-type: none"> - the station distance from the centre of the region, assuming a spherical Earth, is less than or equal to the distance k associated with the vertex k having greatest radial k less than or equal to the station's radial from the centre of the defined region; or <p>Condition 2b: radial range compliance when there is no vertex with radial k less than or equal to the station's radial from the centre of the defined region</p> <ul style="list-style-type: none"> - the station distance from the centre of the region, assuming a spherical Earth, is less than or equal to the distance k_{vc} associated with the last vertex in the list.
NOTE 1: The (radial, range) pairs may be parsed in a clockwise direction around the defined centre of the region. Each range applies at its associated radial and in a clockwise direction until another radial is encountered.	
NOTE 2: A station that matches the regional broadcast filter operates according to the directed rate mechanism.	

Table 5.30: Regional multicast block bit encoding

Description	Octet	Bit number								
		8	7	6	5	4	3	2	1	
vertex count (vc)	1	1	res	lon ₁₄	lon ₁₃	vc ₄	vc ₃	vc ₂	vc ₁	
centre latitude (lat, lat ₄)	2	lon ₈	lon ₇	lon ₆	lon ₅	lon ₄	lon ₃	lon ₂	lon ₁	
	3	lon ₁₂	lon ₁₁	lon ₁₀	lon ₉	lat ₁₂	lat ₁₁	lat ₁₀	lat ₉	
centre longitude (lon, lon ₄)	4	lat ₈	lat ₇	lat ₆	lat ₅	lat ₄	lat ₃	lat ₂	lat ₁	
	5	lon ₄₄	lon ₄₃	lon ₄₂	lon ₄₁	lat ₄₄	lat ₄₃	lat ₄₂	lat ₄₁	
lower altitude (lalt)	6	lalt ₈	lalt ₇	lalt ₆	lalt ₅	lalt ₄	lalt ₃	lalt ₂	lalt ₁	
upper altitude (ualt)	7	ualt ₈	ualt ₇	ualt ₆	ualt ₅	ualt ₄	ualt ₃	ualt ₂	ualt ₁	
vertex 1	radial 1 (r ₁)	8	r _{1,8}	r _{1,7}	r _{1,6}	r _{1,5}	r _{1,4}	r _{1,3}	r _{1,2}	r _{1,1}
	distance 1 (d ₁)	9	d _{1,8}	d _{1,7}	d _{1,6}	d _{1,5}	d _{1,4}	d _{1,3}	d _{1,2}	d _{1,1}
vertex 2 (as needed)	radial 2 (r ₂)	10	r _{2,8}	r _{2,7}	r _{2,6}	r _{2,5}	r _{2,4}	r _{2,3}	r _{2,2}	r _{2,1}
	distance 2 (d ₂)	11	d _{2,8}	d _{2,7}	d _{2,6}	d _{2,5}	d _{2,4}	d _{2,3}	d _{2,2}	d _{2,1}

Table 5.31: Regional multicast block field encoding

Subfield	Encoding	Notes
Vertex count (vc)	0: vertex 1 1- 15: vertex 2 to vertex 16	vertex k corresponds to radial k and distance k.
centre latitude (lat, lat4) centre longitude (lon, lon4)	lat, lon, lat4, lon4 are CPR encoded per clause 5.1.6. and per EN 301 842-2 [5], clause 5.6.	Sent using type=0, reference position is location of station transmitting this parameter.
lower altitude (lalt) upper altitude (uait)	0: alt = -1 500 feet 1: alt = -1 250 feet 2 - 254: 250 ft linear increments up to 63 500 feet 255: no upper limit	Station only matches the broadcast if its altitude (baro if available, otherwise geo) is between lower and upper altitudes. Altitude code 255 is not valid for lower altitude.
distance (d)	See table 5.32.	Vertex blocks are listed in monotonically increasing radial order (clockwise around centre).
radial (r)	due North coded as 0. Resolution is 360/256 degrees, linear.	

Table 5.32: Vertex distance encoding

Transmitted value of distance (decimal equivalent of field)	Within region if:
0	distance < 0,5 NM
1	distance < 1,0 NM
↓	↓
59	distance < 29,5 NM
60	distance < 30 NM
61	distance < 31 NM
↓	↓
89	distance < 59 NM
90	distance < 60 NM
91	distance < 62 NM
↓	↓
119	distance < 118 NM
120	distance < 120 NM
121	distance < 124 NM
↓	↓
254	distance < 656 NM
255	distance < 660 NM

Requirement reference	
	Cancellation of channel management parameter command
5.1.5.2.18	A station shall cancel a channel management parameter command with known csid by transmitting a channel management parameter with the directed timeout subfield set to 15, the directed offset (do) set to the offset from the first slot of the cancellation channel management parameter to the first slot for which the reservation shall be cancelled, and all other subfields set to the same values as in the original channel management parameter to be cancelled.
5.1.5.2.19	A station shall cancel the set of all channel management parameter commands for a station or set of stations by transmitting a channel management parameter with csid = 15.
	Transmission block encoding
	Pre-defined transmission block definitions
5.1.5.2.20	The ordered list of pre-defined transmission blocks defined in table 5.33 shall be referenced by the transmission definition index (txd) subfield (see table 5.42) in the script block when the non-standard definition (nsd) subfield (see table 5.42) is equal to zero.

Table 5.33: Pre-defined transmission block definition encoding

Encoding	Transmission definition
0	Sync burst with baro altitude, no sleep parameters, basic variable field, baro alt rate.
1	Sync burst with geo altitude, no sleep parameters, basic variable field, geo alt rate.
2	Sync burst with baro altitude, no sleep parameters, full position variable field.
3	Sync burst with baro altitude, no sleep parameters, aircraft data variable field.
4 - 15	reserved.

NOTE: If the preferred altitude encoding is not available, then send the other if it is available.

Requirement reference	User-defined transmission block
5.1.5.2.21	Zero to fifteen user-defined transmission blocks shall be defined in the transmission block definition clause as indicated by the tc field (see table 5.27).
5.1.5.2.22	User-defined transmission blocks shall be encoded as defined in tables 5.34 and 5.36.

NOTE: Octets 3 through to len+2 are all application-specific.

Table 5.34: User-defined synchronization burst transmission block bit encoding

Description	Octet	Bit number							
		8	7	6	5	4	3	2	1
ID (id)	1	id ₄	id ₃	id ₂	id ₁	aux ₂	aux ₁	b/g	0
ID-extension (if required)	2	id ₁₄	id ₁₃	id ₁₂	id ₁₁	id ₂₄	id ₂₃	id ₂₂	id ₂₁

NOTE 1: "aux" refers to auxiliary parameter.
NOTE 2: "b/g" refers to baro/geo altitude.

Table 5.35: User-defined synchronization burst transmission block field encoding

Subfield	Encoding	Notes
baro/geo selection (b/g)	b/g = 0: send baro b/g = 1: send geo	If the preferred altitude encoding is not available, then send the other if it is available.
variable field ID (and extensions)	Per table 5.1	Octet 2 is only included when necessary.
auxiliary selection (aux)	For those variable fields with a selection (e.g. basic, high dynamic, TCP), send selection = aux.	If the requested data is not available, but the alternate is, then send the alternate. As an example, for the basic variable field, aux=0 means send baro rate.

Table 5.36: Non-sync burst transmission block bit encoding

Description	Octet	Bit number							
		8	7	6	5	4	3	2	1
message ID (mid)	1	mid ₈	mid ₇	mid ₆	mid ₅	mid ₄	mid ₃	mid ₂	mid ₁
length (len), application specific (app)	2	app _j	app _{j-1}	app ₁	len ₄	len ₃	len ₂	len ₁

NOTE: Octets 2 through to len+2 are all application specific.

..... [Denotes variable length field]

Table 5.37: Non-sync burst transmission block field encoding

Subfield	Encoding	Notes
application specific data (app)		Defined by the application specified by the message ID.
length (len)	0 - 15	Number of octets following the length (i.e. an application requiring only 4 bits of parameters would encode a 0 for length).
message ID (mid)	Per [5], table 5.3	Note that mid ₁ equals 1 for all message types except the synchronization burst - hence this bit distinguishes the format of table 5.34 from that of table 5.36.

Requirement reference	
	Frequency block encoding
5.1.5.2.23	Zero to seven frequencies (as indicated by the fc field in the header block) shall be encoded as defined in table 5.38 with subfield encodings as defined in table 5.39.
5.1.5.2.23aa	The frequencies in the frequency block shall be ordered in priority such that mandatory frequencies are listed first.
5.1.5.2.23ab	The GSC channels shall always be included in the frequency block as mandatory frequencies (rcv = 1), and always listed before non-GSC frequencies.

Table 5.38: Frequency block bit encoding

Description	Octet	Bit number							
		8	7	6	5	4	3	2	1
flags	1	sleep	auto	rcv	res	f ₁₂	f ₁₁	f ₁₀	f ₉
freq	2	f ₈	f ₇	f ₆	f ₅	f ₄	f ₃	f ₂	f ₁
NOTE 1: "sleep" denotes autonomous monitoring.									
NOTE 2: "auto" denotes autonomous information.									
NOTE 3: "rcv" denotes Must Receive.									
NOTE 4: "res" denotes reserved bit.									

Table 5.39: Frequency block field encoding

Subfield	Encoding	Notes
frequency (f)	See [5], table 5.26	
must receive (rcv)	rcv = 0: reception on the specified frequency is optional. rcv = 1: reception on the specified frequency is mandatory.	As the list is ordered in priority, a station receiving a list with a frequency with rcv=0 before a frequency with rcv=1 shall discard the entire channel management parameter.
sleep	Per clauses 5.1.2.2 and 5.1.2.3.	If the sleep bit is set, then the octets defined in table 5.20 are appended.
auto	auto = 0: the receiving station shall choose its transmissions autonomously and ignore any reference to this frequency in the script block. auto = 1: the receiving station shall transmit on this frequency according to the definition in the script block.	If the auto bit is set to 0, the script block shall not refer to this frequency.

Requirement reference	Parameter block definition
5.1.5.2.24	The transmitting station shall include parameter octets defined in table 5.40 if it desires the receiving station to transmit all of the streams defined in the script using those parameters.
NOTE: Transmit parameter count (pc) would be greater than the length of table 5.40 if more parameters were added after the software was released.	

Table 5.40: Parameter block bit encoding

Description	Octet	Bit number							
		8	7	6	5	4	3	2	1
Q2a	1	Q2a ₈	Q2a ₇	Q2a ₆	Q2a ₅	Q2a ₄	Q2a ₃	Q2a ₂	Q2a ₁
Q2b	2	Q2b ₈	Q2b ₇	Q2b ₆	Q2b ₅	Q2b ₄	Q2b ₃	Q2b ₂	Q2b ₁
Q2c	3	Q2c ₈	Q2c ₇	Q2c ₆	Q2c ₅	Q2c ₄	Q2c ₃	Q2c ₂	Q2c ₁
Q2d	4	Q2d ₈	Q2d ₇	Q2d ₆	Q2d ₅	Q2d ₄	Q2d ₃	Q2d ₂	Q2d ₁
Q2a, Q2b, Q2c, Q2d	5	Q2d ₁₀	Q2d ₉	Q2c ₁₀	Q2c ₉	Q2b ₁₀	Q2b ₉	Q2a ₁₀	Q2a ₉
Q1, Q4	6	Q1 ₃	Q1 ₂	Q1 ₁	Q4 ₅	Q4 ₄	Q4 ₃	Q4 ₂	Q4 ₁
Q1, V12	7	Q1 ₄	V12 ₇	V12 ₆	V12 ₅	V12 ₄	V12 ₃	V12 ₂	V12 ₁
VS2 (db)	8	res	res	VS2 ₆	VS2 ₅	VS2 ₄	VS2 ₃	VS2 ₂	VS2 ₁
VS4 (NM)	9	res	VS4 ₇	VS4 ₆	VS4 ₅	VS4 ₄	VS4 ₃	VS4 ₂	VS4 ₁
NOTE: "res" refers to bits available for the information field.									

Requirement reference	Script block definition
5.1.5.2.25	The channel management parameter script shall be encoded as defined in table 5.41 with subfield encoding as defined in table 5.42.
5.1.5.2.26	The script block shall contain one or more script elements.
5.1.5.2.27	The two types of script elements shall be as shown in table 5.41.
5.1.5.2.28	A transmitting station shall not transmit a script block with two consecutive octets having bits 6 - 8 equal to "111".

Table 5.41: Script block bit encoding

Description	Octet	Bit number							
		8	7	6	5	4	3	2	1
freq index (freq), transmission definition index (txd)	1	freq ₃	freq ₂	freq ₁	nsd	txd ₄	txd ₃	txd ₂	txd ₁
					or				
repeat count (rpt)	1	1	1	1	rpt ₅	rpt ₄	rpt ₃	rpt ₂	rpt ₁
freq index (freq), non-standard definition (nsd), transmission definition index (txd)	2	freq ₃	freq ₂	freq ₁	nsd	txd ₄	txd ₃	txd ₂	txd ₁

Table 5.42: Script block field encoding

Subfield	Encoding	Notes
Frequency index (frq)	0 - 6 : integer index into freq block 7 : repeat flag (second octet with freq index follows).	The offset from the beginning of the frequency list. (An encoding of 0 refers to the first element in the frequency block.)
Non-standard definition (nsd)	nsd = 0: txd encoded as defined in table 5.33. nsd = 1: txd indicates offset from beginning of transmission definition list (see clause 5.1.5.2.18).	
Transmission definition index (txd)	0 - 15	The offset from the beginning of the transmission definition list (An encoding of 0 refers to the first element in the list.)
Repeat count (rpt)	3 (encoded as 0) to 34	The number of times to repeat the frequency and (nsd, txd) listed in octet 2.

5.1.6 Definitions for Compact Position Reporting

5.1.6.1 Information Field Offset Encoding

Requirement reference	
	General
5.1.6.1.1	Given a position and its fixed data field encoding, a high resolution offset encoding of size <i>bits</i> together with an additional bit indicating the sign of the offset shall be computed as defined below.
5.1.6.1.2	The offset shall be encoded in the sub-fields lat4, lon4 (for <i>bits</i> = 3), lat6, lon6 (for <i>bits</i> = 5) or lat8, lon8 (for <i>bits</i> = 7) dependent on which synchronization burst variable part is to be transmitted.
	Input parameters
5.1.6.1.3	The input parameters used for information field offset encoding shall be defined as follows: <i>clat_{in}</i> = latitude to be encoded. <i>clon_{in}</i> = longitude to be encoded. <i>lat</i> = the CPR encoded latitude. <i>lon</i> = the CPR encoded longitude. <i>type</i> = type of CPR (odd or even). <i>bits</i> = number of bits in magnitude of the offset.
	Calculations
	Supporting functions
5.1.6.1.4	The supporting function for calculating the information field offset shall be as follows: $\text{diff}(pos_1, pos_2) = \begin{cases} pos_1 - pos_2 - MAX_C - 1 & \text{if } pos_1 > pos_2 + MAX_C / 2 \\ pos_1 - pos_2 + MAX_C + 1 & \text{if } pos_2 > pos_1 + MAX_C / 2 \\ pos_1 - pos_2 & \text{else} \end{cases}$ $\text{sign}(pos_1, pos_2) = \begin{cases} 1 & \text{if } \text{diff}(pos_1, pos_2) \geq 0 \\ 0 & \text{else} \end{cases}$

Requirement reference	
5.1.6.1.5	<p style="text-align: center;">Latitude</p> <p>The encoded fixed latitude offset shall be calculated as follows:</p> $lat = enc_{lat}(clat_{in}, type)$ $clat_{dec} = dec_{lat}(clat_{in}, lat, lat, type)$ $tmp_7 = \frac{MAX_C}{2 \cdot nz(type) \cdot MAX_T^{lat} \cdot (2^{bits} - 1)}$ $offset_{enc}^{lat}(clat_{in}, clat_{dec}, bits, type) = \frac{ diff(clat_{in}, clat_{dec}) + \frac{tmp_7}{2}}{tmp_7}$ $lat4(bits\ 1\ to\ 3) = offset_{enc}^{lat}(clat_{in}, clat_{dec}, 3, type)$ $lat6(bits\ 1\ to\ 5) = offset_{enc}^{lat}(clat_{in}, clat_{dec}, 5, type)$ $lat8(bits\ 1\ to\ 7) = offset_{enc}^{lat}(clat_{in}, clat_{dec}, 7, type)$ $lat4(bit\ 4) = lat6(bit\ 6) = lat8(bit\ 8) = sign(clat_{in}, clat_{dec})$
5.1.6.1.6	<p style="text-align: center;">Longitude</p> <p>The encoded fixed longitude offset shall be calculated as follows:</p> $lon = enc_{lon}(clat_{dec}, clon_{in}, type)$ $clon_{dec} = dec_{lon}(clat_{dec}, clon_{in}, lon, lon, type)$ $tmp_8 = \frac{MAX_C}{2 \cdot nl(clat_{dec}, type) \cdot MAX_T^{lon} \cdot (2^{bits} - 1)}$ $offset_{enc}^{lon}(clat_{dec}, clon_{in}, clon_{dec}, bits, type) = \frac{ diff(clon_{in}, clon_{dec}) + \frac{tmp_8}{2}}{tmp_8}$ $lon4(bits\ 1\ to\ 3) = offset_{enc}^{lon}(clat_{dec}, clon_{in}, clon_{dec}, 3, type)$ $lon6(bits\ 1\ to\ 5) = offset_{enc}^{lon}(clat_{dec}, clon_{in}, clon_{dec}, 5, type)$ $lon8(bits\ 1\ to\ 7) = offset_{enc}^{lon}(clat_{dec}, clon_{in}, clon_{dec}, 7, type)$ $lon4(bit\ 4) = lon6(bit\ 6) = lon8(bit\ 8) = sign(clon_{in}, clon_{dec})$

5.1.6.2 Information Field Offset Decoding

Requirement reference	
	General
5.1.6.2.1	To decode the information field latitude and longitude offsets, the offset values defined below shall be added to the position from the fixed data field position decoding (either local or global) to determine the actual target position.
	Input parameters
5.1.6.2.2	The input parameters used for information field offset decoding shall be defined as follows: <i>lat4, lat6, lat8</i> = received latitude offset. <i>lon4, lon6, lon8</i> = received longitude offset. <i>type</i> = type of encoding (odd or even). <i>clatdec</i> = the target's decoded latitude.
	Calculations
	Latitude
5.1.6.2.3	The decoded fixed latitude offset shall be calculated as follows: $bits = \begin{cases} 3 & \text{if } lat4, lon4 \text{ provided as input} \\ 5 & \text{if } lat6, lon6 \text{ provided as input} \\ 7 & \text{if } lat8, lon8 \text{ provided as input} \end{cases}$ $lat_{offs} = \begin{cases} lat4(bits\ 1\ to\ 3) & \text{if } lat4, lon4 \text{ provided as input} \\ lat6(bits\ 1\ to\ 5) & \text{if } lat6, lon6 \text{ provided as input} \\ lat8(bits\ 1\ to\ 7) & \text{if } lat8, lon8 \text{ provided as input} \end{cases}$ $s_{lat} = \begin{cases} lat4(bit\ 4) & \text{if } lat4, lon4 \text{ provided as input} \\ lat6(bit\ 6) & \text{if } lat6, lon6 \text{ provided as input} \\ lat8(bit\ 8) & \text{if } lat8, lon8 \text{ provided as input} \end{cases}$ $tmp_9 = \frac{MAX_c}{2 \cdot nz(type) \cdot MAX_T^{lat} \cdot (2^{bits} - 1)}$ $offset_{dec}^{lat}(lat_{offs}, s_{lat}, bits, type) = \begin{cases} lat_{offs} \cdot tmp_7 & \text{if } s_{lat} = 1 \\ -lat_{offs} \cdot tmp_7 & \text{if } s_{lat} = 0 \end{cases}$
	Longitude
5.1.6.2.4	The decoded fixed longitude offset shall be calculated as follows: $lon_{offs} = \begin{cases} lon4(bits\ 1\ to\ 3) & \text{if } lat4, lon4 \text{ provided as input} \\ lon6(bits\ 1\ to\ 5) & \text{if } lat6, lon6 \text{ provided as input} \\ lon8(bits\ 1\ to\ 7) & \text{if } lat8, lon8 \text{ provided as input} \end{cases}$ $s_{lon} = \begin{cases} lon4(bit\ 4) & \text{if } lat4, lon4 \text{ provided as input} \\ lon6(bit\ 6) & \text{if } lat6, lon6 \text{ provided as input} \\ lon8(bit\ 8) & \text{if } lat8, lon8 \text{ provided as input} \end{cases}$ $tmp_{10} = \frac{MAX_c}{2 \cdot nl(clat_{dec}, type) \cdot MAX_T^{lon} \cdot (2^{bits} - 1)}$ $offset_{dec}^{lon}(clat_{dec}, lon_{offs}, s_{lon}, bits, type) = \begin{cases} lon_{offs} \cdot tmp_8 & \text{if } s_{lon} = 1 \\ -lon_{offs} \cdot tmp_8 & \text{if } s_{lon} = 0 \end{cases}$
	NOTE 1: <i>tmp₇</i> is defined in 5.1.6.1.5. NOTE 2: <i>tmp₈</i> is defined in 5.1.6.1.6.

5.1.6.3 Patch ID Encoding

Requirement reference	
	General
5.1.6.3.1	When a station sends an unambiguous global position in a single message, then it shall transmit the value of $enc_{patch}()$ as the patch ID (pid).
	Input parameters
5.1.6.3.2	The input parameters used for patch ID encoding shall be defined as follows: $clat_{in}$ = latitude to encode. $clon_{in}$ = longitude to encode. $type$ = type of encoding (odd or even).
	Calculations
5.1.6.3.3	The encoded patch ID shall be calculated as follows: $lat_p = \begin{cases} \frac{clat_{in}}{dlat(type)} & \text{if } 0 \leq clat_{in} \leq \frac{MAX_c}{4} \\ \frac{clat_{in}}{dlat(type)} - 16 & \text{if } clat_{in} > \frac{MAX_c}{4} \end{cases}$ $lat = enc_{lat}(clat_{in}, type)$ $clat_{dec} = dec_{lat}(clat_{in}, lat, lat, type)$ $lon_p = \frac{clon_{in}}{dlon(clat_{dec}, type)}$ $pid = enc_{patch}(lat_p, lon_p) = 36 \cdot lat_p + lon_p$ $offset_{dec}^{lat}(lat_{offs}, s_{lat}, bits, type) = \begin{cases} lat_{offs} \cdot tmp_7 & \text{if } s_{lat} = 1 \\ -lat_{offs} \cdot tmp_7 & \text{if } s_{lat} = 0 \end{cases}$

5.1.6.4 Patch ID Decoding

Requirement reference	
	General
5.1.6.4.1	The patch ID decoding shall use the received patch ID, lat and lon subfields and decode this to a position in latitude and longitude, which is globally unambiguous.
	Input parameters
5.1.6.4.2	The input parameters used for patch ID decoding shall be defined as follows: <i>lat</i> = CPR latitude to decode. <i>lon</i> = CPR longitude to be decode. <i>type</i> = type of encoding (odd or even). <i>pid</i> = encoded patch id.
	Calculations
	Latitude
5.1.6.4.3	The decoded latitude component of the patch ID shall be calculated as follows: $lat_p = \begin{cases} \frac{pid}{36} & \text{if } 0 \leq pid \leq 359 \\ \frac{pid}{36} + 16 & \text{if } pid > 359 \end{cases}$ $fullDec_{lat}(lat, lat_p, type) = \frac{\left(\left(\frac{MAX_C}{MAX_T^{lat}} \right) \cdot lat \right)}{nz(type)} + dlat(type) \cdot lat_p$
	Longitude
5.1.6.4.4	The patch ID longitude component shall be calculated as follows: $lon_p = \text{mod}(pid, 36)$ $clat_{dec} = fullDec_{lat}(lat, lat_p, type)$ $fullDec_{lon}(clat_{dec}, lon, lon_p, type) = \frac{\left(\left(\frac{MAX_C}{MAX_T^{lon}} \right) \cdot lon \right)}{nl(clat_{dec}, type)} + dlon(clat_{dec}, type) \cdot lon_p$

5.1.7 Encoding of UDATA (udid)

Requirement reference	
5.1.7.1	The UDATA ID (udid) field shall be encoded as defined in table 5.42a.

Table 5.42a: Encoding of UDATA ID (udid)

Service	UDATA ID (udid)
TIS-B	00000bin
FIS-B	00001bin
Reserved	00010bin
GNS-B	00011bin
Reserved	00100bin to 11101bin

5.2 Requirements for TIS-B

5.2.1 Traffic Information Volume (TIV)

Requirement reference	
5.2.1.1	Each ground station shall support between 1 and 8 TIVs (airborne and/or ground).
5.2.1.2	Each TIV from a ground station shall be identified by a TIV identity code (TIV ID).
5.2.1.3	Each TIV shall be uniquely determined by the combination of the ground station 24-bit ICAO address (sent in every VDL Mode 4 burst) and the TIV ID.
5.2.1.4	A TIV shall be either a polygon shape with a maximum of 10 vertices, or a circle with a radius defined by one vertex. NOTE 1: A polygon TIV may be concave or convex. NOTE 2: Other TIV shapes may be defined in future by encoding only one or two vertices.
5.2.1.5	The TIV polygon shall be two-dimensional and not have any crossing borders.
5.2.1.6	No vertices shall be the same for a TIV.
5.2.1.7	Each TIV shall have a minimum altitude limit and a greater maximum altitude limit. NOTE: The minimum and maximum altitude limits should not be the same. The altitude limit applies in the whole TIV.
5.2.1.8	A TIV shall support the provision of either a "full surveillance picture" or a "gap filler service".
5.2.1.9	The target with the lowest position quality (i.e. accuracy) in each TIV shall be used as the quality parameter of the whole TIV and broadcast in the management message.
5.2.1.10	All targets inside a TIV shall have position accuracy appropriate to the quality parameter of the TIV or better.
5.2.1.11	A single TIS-B target update rate shall be applied in the TIV.
5.2.1.12	A TIV shall be suspended before it is overloaded and no target messages shall be broadcast for the overloaded TIV.
5.2.1.13	The status information (OK, not OK, or overloaded) of a TIV shall be sent in the management message.

5.2.2 Message transmission

5.2.2.1 Management messages

Requirement reference	
5.2.2.1.1	Management messages shall be transmitted once each TIV update period.
5.2.2.1.2	Each TIV update period shall start with a management message.
5.2.2.1.3	Each management message shall include information about one TIV. NOTE: Each TIV has one management message.
5.2.2.1.4	The transmission of the management message for the following TIV period shall not be initiated before all target messages of the current TIV period are transmitted.

5.2.2.2 Target messages

Requirement reference	
5.2.2.2.1	Each target message shall be transmitted once every update period for each TIV the target is included in.
5.2.2.2.2	In Gap-filler mode a target message shall be transmitted for an ADS-B equipped aircraft if either of the following circumstances occur: <ul style="list-style-type: none"> • ADS-B equipment on aircraft fails or is out of tolerance margins. • Insufficient ADS-B performance. NOTE: Full surveillance shall be used carefully. The link load is significantly increased for a full surveillance TIV compared with a gap-filler TIV. Special cases are volumes with known shadings (e.g. buildings on an airport, mountains).
5.2.2.2.3	The ground system shall only uplink the most recently available TIS-B report for an aircraft.
5.2.2.2.4	The ground system shall cease to transmit target reports for an aircraft when no radar data has been received for that aircraft for a specified period of time.

5.2.2.3 Airport operation

Requirement reference	
5.2.2.3.1	For a ground TIV, targets shall be identified as either aircraft or ground vehicles and the appropriate message format transmitted accordingly.
5.2.2.3.2	All latitude and longitude positions shall be transmitted with higher resolution for a ground TIV than for an airspace TIV.
5.2.2.3.3	For a ground TIV, if no information is available for a target to confirm that it is an aircraft (27 bit ICAO code, Mode A code, callsign, registration marking or emitter category), then it shall be transmitted as a vehicle target until further information is provided.

5.2.3 Message format

Requirement reference	
5.2.3.1	A TIS-B burst shall be sent in a DLS UDATA DLPDU burst of type UINFO as described clause 5.3 of EN 301 842-2 [5].
5.2.3.2	The UDATA ID (udid) field in octet 5 of a TIS-B burst shall be set to "00000" (see clause 5.3.1.3 of EN 301 842-2 [5]).
5.2.3.3	TIS-B messages shall be placed in the information field of a VDL Mode 4 burst, with the first message starting in bit 1 of octet 6.
5.2.3.4	Where more than one TIS-B message is sent in one TIS-B burst, each additional TIS-B message shall start in bit 1 of the octet following the last octet occupied by the previous TIS-B message.
5.2.3.5	Where more than one TIS-B message is sent in one TIS-B burst, if the previous TIS-B message does not finish at an octet boundary, up to 7 bits of zeros shall be added to complete the octet, prior to the start of the subsequent TIS-B message.
5.2.3.6	Each TIS-B message shall start with a TIS-B message identifier (tmi), as defined in table 5.43.
5.2.3.7	To indicate a TIS-B message identifier greater than 14, bits 1 to 4 of octet n+1 shall be set to 15, and a further 8 bits of tmi1 shall be inserted starting in bit 5 of octet n+1 and ending in bit 4 of octet n+2, so that $tmi = 15 + tmi1$.
5.2.3.8	Each TIS-B burst shall use either: <ul style="list-style-type: none"> • a reservation ID (rid) equal to 1, with the burst appended by a null reservation field as defined in clause 5.2.9 of EN 301 842-2 [5]; • or a reservation ID (rid) equal to 0 and an extended reservation ID (erid) equal to 00000binary, with the burst appended by a response reservation field as defined in clause 5.2.18 of EN 301 842-2 [5], with address type field equal to 7; • a reservation ID (rid) equal to 1, with the burst appended by a periodic broadcast reservation field as defined in clause 5.2.10 of EN 301 842-2 [5]; • a reservation ID (rid) equal to 0, with the burst appended by an incremental broadcast reservation field as defined in clause 5.2.11 of EN 301 842-2 [5]; • a reservation ID (rid) equal to 1, with the burst appended by a combined periodic broadcast and incremental broadcast reservation field as defined in clause 5.2.12 of EN 301 842-2 [5]; • or a reservation ID (rid) equal to 0, with the burst appended by a unicast reservation field with sdf=1 as defined in clause 5.2.14 of EN 301 842-2 [5]; • or a reservation ID (rid) equal to 0, with the burst appended by a second frame reservation field as defined in clause 5.2.17 of EN 301 842-2 [5]; • or a reservation ID (rid) equal to 0, with the burst appended by a superframe reservation field as defined in clause 5.2.17 of EN 301 842-2 [5].

Table 5.43: TIS-B message identifier encoding

Message	TIS-B Message ID Encoded value	8-bit Message ID Extension (tmi1) Encoded value
Management message	0	not present
Aircraft target (airborne TIV)	1	not present
Aircraft target (ground TIV)	2	not present
Ground vehicle target (ground TIV)	3	not present
Reserved for future use	4 - 14	not present
Available for future use with 8-bit extension	15	0 - 255

5.2.4 Management message

Requirement reference	
5.2.4.1	The management message shall be encoded as defined in table 5.44.
5.2.4.2	Fields in the management message shall be encoded as defined in table 5.45.
5.2.4.3	The latitude/longitude coordinates of a fixed virtual reference position shall be sent in the management message and given in absolute WGS-84 coordinates.
5.2.4.4	The latitude/longitude positions of the TIV vertices sent in the management message shall be encoded as an offset from the reference position.
5.2.4.5	All latitude/longitude positions in the target messages shall be encoded as an offset from the reference position.

Table 5.44: Management message bit encoding

Description	Octet	Bit number							
		8	7	6	5	4	3	2	1
udid, ucd	5	0	0	0	0	0	1	1	1
TIS-B message ID (tmi) version number (vers)	n	vers ₄	vers ₃	vers ₂	vers ₁	tmi ₄	tmi ₃	tmi ₂	tmi ₁
TIV ID (tivid) update period (up)	n + 1	up ₅	up ₄	up ₃	up ₂	up ₁	tivid ₃	tivid ₂	tivid ₁
TIV status (tivs) TIS-B target resolution (tacc)	n + 2	lat ₁	tacc ₄	tacc ₃	tacc ₂	tacc ₁	tivs ₂	tivs ₁	up ₆
reference point latitude (lat)	n + 3	lat ₉	lat ₈	lat ₇	lat ₆	lat ₅	lat ₄	lat ₃	lat ₂
reference point longitude (long)	n + 4	long ₃	long ₂	long ₁	lat ₁₄	lat ₁₃	lat ₁₂	lat ₁₁	lat ₁₀
	n + 5	long ₁₁	long ₁₀	long ₉	long ₈	long ₇	long ₆	long ₅	long ₄
lower barometric altitude (lbar)	n + 6	lbar ₄	lbar ₃	lbar ₂	lbar ₁	long ₁₅	long ₁₄	long ₁₃	long ₁₂
upper barometric altitude (ubar)	n + 7	ubar ₄	ubar ₃	ubar ₂	ubar ₁	lbar ₈	lbar ₇	lbar ₆	lbar ₅
number of vertices (nvert)	n + 8	nvert ₄	nvert ₃	nvert ₂	nvert ₁	ubar ₈	ubar ₇	ubar ₆	ubar ₅
vertex latitude (vlat(1-k))	n + 9	vlat ₁₈	vlat ₁₇	vlat ₁₆	vlat ₁₅	vlat ₁₄	vlat ₁₃	vlat ₁₂	vlat ₁₁
vertex longitude (vlg(1 -k))	n + 10	vlg ₁₈	vlg ₁₇	vlg ₁₆	vlg ₁₅	vlg ₁₄	vlg ₁₃	vlg ₁₂	vlg ₁₁
								
	n + 2k + 7	vlat _{k8}	vlat _{k7}	vlat _{k6}	vlat _{k5}	vlat _{k4}	vlat _{k3}	vlat _{k2}	vlat _{k1}
	n + 2k + 8	vlg _{k8}	vlg _{k7}	vlg _{k6}	vlg _{k5}	vlg _{k4}	vlg _{k3}	vlg _{k2}	vlg _{k1}

..... [Denotes variable length field]

Table 5.45: Management message field encoding

Data field	Definition	Encoded Value
TIS-B message ID	See table 5.43	0
TIS-B service version	TIS-B as defined in the present document Unused	0 1 to 15
TIV ID	1 to 8	0 to 7
Update period	0,5 s 1,0 s 2,0 s 3,0 s ↓ 60 s Unused	0 1 2 3 ↓ 60 61 to 63
TIV status	OK Not OK Overloaded Unused	0 1 2 3
TIS-B target resolution	See position Navigation Integrity Category (NIC) encoding in table 5.59 in clause 5.4.2.3 of EN 301 842-2 [5].	
Reference point latitude	Encoded reference point latitude = (latitude) × 60 + 5 400, where latitude has an increment of 1/60 th of a degree and range between -90 degrees and +90 degrees Unused	0 to 10 800 10 801 to 16 383
Reference point longitude	Encoded reference point longitude = (longitude) × 60 + 10 800, where longitude has an increment of 1/60 th of a degree and range between -180 degrees and +180 degrees. Unused	0 to 21 600 21 601 to 32 767
Lower barometric altitude	-1 500 feet -1 250 feet 250 ft linear increments up to 63 500 feet Encoding of 255 is not allowed	0 1 2 to 254
Upper barometric altitude	-1 500 feet -1 250 feet 250 ft linear increments up to 63 500 feet No upper limit	0 1 2 to 254 255
Number of vertices	Defines a specific TIV shape or the number of polygon vertices: Circle with centre at reference position and radius specified by one vertex position (comprising vlat1 and vlg1); No. of polygon vertices (3 to 10); Unused (see note); Other method of TIV shape definition or an indication of additional number of vertices is defined in an additional octet in row n+9.	0 1 to 8 9 to 14 15
TIV vertex latitude	Encoded as an offset from the reference position (see clause 5.2.8).	
TIV vertex longitude	Encoded as an offset from the reference position (see clause 5.2.8).	
NOTE:	Encodings 9 to 14 could be used in future to encode a number of fixed shapes to save defining all vertices, or to encode further vertices, depending on future requirements. To encode fixed shapes, one or two vertices would be sufficient to define the complete TIV: e.g. square, regular hexagons (two different orientations), rectangle, "stretched" hexagons (two different orientations).	

5.2.5 Aircraft target messages (airborne TIV)

Requirement reference	
5.2.5.1	The aircraft target message (airborne TIV) shall be encoded as defined in table 5.46.
5.2.5.2	The aircraft target message (airborne TIV) shall consist of a fixed and an optional field.
5.2.5.3	The optional field shall consist of flight ID type, flight ID and aircraft category.
5.2.5.4	Flight ID shall be one of the following: <ul style="list-style-type: none"> • callsign; • registration marking.
5.2.5.5	For each target, the optional field shall be transmitted every 3 TIV update periods, or more frequently.
5.2.5.6	If more than one Flight ID is available for a target, then these will be sent in alternate target messages.
5.2.5.7	Fields in the aircraft target message (airborne TIV) shall be encoded as defined in table 5.47.

**Table 5.46: Aircraft target message (airborne TIV) bit encoding
(with callsign as an example flight ID)**

Description	Octet	Bit number							
		8	7	6	5	4	3	2	1
udid, ucd	5	0	0	0	0	0	1	1	1
TIS-B message ID (tmi) TIV ID (tivid) target identifier flag (tflg)	n	tflg	tivid ₃	tivid ₂	tivid ₁	tmi ₄	tmi ₃	tmi ₂	tmi ₁
radar/fusion flag (rflg) ADS-B fault flag (adsff) flight ID flag (fidflg) target identifier (tid)	n + 1	tid ₅	tid ₄	tid ₃	tid ₂	tid ₁	fidflg	adsff	rflg
	n + 2	tid ₁₃	tid ₁₂	tid ₁₁	tid ₁₀	tid ₉	tid ₈	tid ₇	tid ₆
	n + 3	tid ₂₁	tid ₂₀	tid ₁₉	tid ₁₈	tid ₁₇	tid ₁₆	tid ₁₅	tid ₁₄
latitude (rlat)	n + 4	rlat ₅	rlat ₄	rlat ₃	rlat ₂	rlat ₁	tid ₂₄	tid ₂₃	tid ₂₂
	n + 5	rlat ₁₃	rlat ₁₂	rlat ₁₁	rlat ₁₀	rlat ₉	rlat ₈	rlat ₇	rlat ₆
longitude (rlg)	n + 6	rlg ₅	rlg ₄	rlg ₃	rlg ₂	rlg ₁	rlat ₁₆	rlat ₁₅	rlat ₁₄
	n + 7	rlg ₁₃	rlg ₁₂	rlg ₁₁	rlg ₁₀	rlg ₉	rlg ₈	rlg ₇	rlg ₆
ground track (gtk)	n + 8	gtk ₅	gtk ₄	gtk ₃	gtk ₂	gtk ₁	rlg ₁₆	rlg ₁₅	rlg ₁₄
barometric altitude (bar)	n + 9	bar ₅	bar ₄	bar ₃	bar ₂	bar ₁	gtk ₈	gtk ₇	gtk ₆
ground speed (gsp)	n + 10	gsp ₁	bar ₁₂	bar ₁₁	bar ₁₀	bar ₉	bar ₈	bar ₇	bar ₆
	n + 11	gsp ₉	gsp ₈	gsp ₇	gsp ₆	gsp ₅	gsp ₄	gsp ₃	gsp ₂
time stamp (tag)	n + 12	tag ₆	tag ₅	tag ₄	tag ₃	tag ₂	tag ₁	gsp ₁₁	gsp ₁₀
flight ID type (fidty)	n + 13	call ₇	call ₆	call ₅	call ₄	call ₃	call ₂	call ₁	fidty
callsign (call)(example)	n + 14	call ₁₅	call ₁₄	call ₁₃	call ₁₂	call ₁₁	call ₁₀	call ₉	call ₈
	n + 15	call ₂₃	call ₂₂	call ₂₁	call ₂₀	call ₁₉	call ₁₈	call ₁₇	call ₁₆
	n + 16	call ₃₁	call ₃₀	call ₂₉	call ₂₈	call ₂₇	call ₂₆	call ₂₅	call ₂₄
	n + 17	call ₃₉	call ₃₈	call ₃₇	call ₃₆	call ₃₅	call ₃₄	call ₃₃	call ₃₂
aircraft category (cat)	n + 18	cat ₅	cat ₄	cat ₃	cat ₂	cat ₁	call ₄₂	call ₄₁	call ₄₀

Table 5.47: Aircraft target message (airborne TIV) field encoding

Data field	Definition	Encoded Value
TIS-B message ID	See table 5.43.	1
TIV ID	Identifies TIV for ground stations configured to transmit more than one TIV.	0 - 7
Target identifier flag	Aircraft address (24-bit ICAO address) Special identifier (See note).	0 1
Radar fusion flag	TIS-B target based only on radar or multilateration data TIS-B target includes ADS-B as a data source.	0 1
ADS-B fault flag	ADS-B data corresponds with TIS-B data TIS-B data should be used in preference to ADS-B data.	0 1
Flight ID Flag	Optional information is not present. Optional information is present.	0 1
Target identifier	Either aircraft address (24-bit ICAO address) or a special identifier.	
Latitude	Encoded as an offset from the reference position (see clause 5.2.8).	
Longitude	Encoded as an offset from the reference position (see clause 5.2.8).	
Ground track	See ground track encoding in table 5.12.	
Barometric altitude	See altitude encoding in table 5.52 of EN 301 842-2 [5].	
Ground speed	See ground speed encoding in table 5.14.	
Time stamp (relative)	time reference 200 ms after time reference 400 ms after time reference ↓ 11,8 s after time reference Unused	0 1 2 ↓ 59 60 to 63
Flight ID type	Callsign Registration marking (tail number)	0 1
Callsign (See table 5.11)	Callsign is left justified. Valid characters are A - Z, 0 - 9 and null: Assigned A - Z = 0 - 25, 0 - 9 = 26 - 35, null = 36. Callsign is an eight character string "c ₁ , c ₂ , c ₃ , c ₄ , c ₅ , c ₆ , c ₇ , c ₈ ", where: $csl = c_1 37^3 + c_2 37^2 + c_3 37 + c_4$ $csr = c_5 37^3 + c_6 37^2 + c_7 37 + c_8$ csl = left hand part of the callsign, and csr = right hand part	
Registration marking (tail number)	Encoding as for callsign.	
Aircraft category	See aircraft category encoding in table 5.16.	
NOTE:	This is code defined by the ground system. It is unique in the TIV at any time. The first part of the identification could be the Mode A code or the tracker identification for that target followed by a unique number allocated by the ground system.	

5.2.6 Aircraft target messages (ground TIV)

Requirement reference	
5.2.6.1	The aircraft target message (ground TIV) shall be encoded as defined in table 5.48.
5.2.6.2	The aircraft target message (ground TIV) shall consist of a fixed and an optional field.
5.2.6.3	The optional field shall consist of flight ID type, flight ID and aircraft category.
5.2.6.4	Flight ID shall be one of the following: <ul style="list-style-type: none"> • callsign; • registration marking; • or Mode A code.
5.2.6.5	For each target, the optional field shall be transmitted every 3 TIV update periods, or more frequently.
5.2.6.6	If more than 1 Flight ID is available for a target, then these will be sent in alternate target messages.
5.2.6.7	Fields in the aircraft target messages (ground TIV) report shall be encoded as defined in table 5.49.

**Table 5.48: Aircraft target message (ground TIV) bit encoding
(with callsign as an example flight ID)**

Description	Octet	Bit number							
		8	7	6	5	4	3	2	1
udid, ucd	5	0	0	0	0	0	1	1	1
TIS-B message ID (tmi) TIV ID (tivid) target identifier flag (tflg)	n	tflg	tivid ₃	tivid ₂	tivid ₁	tmi ₄	tmi ₃	tmi ₂	tmi ₁
radar/fusion flag (rflg) ADS-B fault flag (adsff) flight ID flag (fidflg) target identifier (tid)	n + 1	tid ₅	tid ₄	tid ₃	tid ₂	tid ₁	fidflg	adsff	rflg
	n + 2	tid ₁₃	tid ₁₂	tid ₁₁	tid ₁₀	tid ₉	tid ₈	tid ₇	tid ₆
	n + 3	tid ₂₁	tid ₂₀	tid ₁₉	tid ₁₈	tid ₁₇	tid ₁₆	tid ₁₅	tid ₁₄
latitude (rlat)	n + 4	rlat ₅	rlat ₄	rlat ₃	rlat ₂	rlat ₁	tid ₂₄	tid ₂₃	tid ₂₂
	n + 5	rlat ₁₃	rlat ₁₂	rlat ₁₁	rlat ₁₀	rlat ₉	rlat ₈	rlat ₇	rlat ₆
longitude (rlg)	n + 6	rlg ₁	rlat ₂₀	rlat ₁₉	rlat ₁₈	rlat ₁₇	rlat ₁₆	rlat ₁₅	rlat ₁₄
	n + 7	rlg ₉	rlg ₈	rlg ₇	rlg ₆	rlg ₅	rlg ₄	rlg ₃	rlg ₂
	n + 8	rlg ₁₇	rlg ₁₆	rlg ₁₅	rlg ₁₄	rlg ₁₃	rlg ₁₂	rlg ₁₁	rlg ₁₀
ground track (gtk)	n + 9	gtk ₅	gtk ₄	gtk ₃	gtk ₂	gtk ₁	rlg ₂₀	rlg ₁₉	rlg ₁₈
ground speed (gsp)	n + 10	gsp ₅	gsp ₄	gsp ₃	gsp ₂	gsp ₁	gtk ₈	gtk ₇	gtk ₆
time stamp (tag)	n + 11	tag ₂	tag ₁	gsp ₁₁	gsp ₁₀	gsp ₉	gsp ₈	gsp ₇	gsp ₆
flight ID type (fidty)	n + 12	res	res	res	res	tag ₆	tag ₅	tag ₄	tag ₃
callsign (call)	n + 13	call ₇	call ₆	call ₅	call ₄	call ₃	call ₂	call ₁	fidty
	n + 14	call ₁₅	call ₁₄	call ₁₃	call ₁₂	call ₁₁	call ₁₀	call ₉	call ₈
	n + 15	call ₂₃	call ₂₂	call ₂₁	call ₂₀	call ₁₉	call ₁₈	call ₁₇	call ₁₆
	n + 16	call ₃₁	call ₃₀	call ₂₉	call ₂₈	call ₂₇	call ₂₆	call ₂₅	call ₂₄
	n + 17	call ₃₉	call ₃₈	call ₃₇	call ₃₆	call ₃₅	call ₃₄	call ₃₃	call ₃₂
aircraft category (cat)	n + 18	cat ₅	cat ₄	cat ₃	cat ₂	cat ₁	call ₄₂	call ₄₁	call ₄₀

Table 5.49: Aircraft target message (ground TIV) field encoding

Data field	Definition	Encoded Value
TIS-B message ID	See table 5.43.	2
TIV ID	Identifies TIV for ground stations configured to transmit more than one TIV.	0 - 7
Target identifier flag	Aircraft address (24-bit ICAO address) Special identifier (See note).	0 1
Radar fusion flag	TIS-B target based only on radar or multilateration data TIS-B target includes ADS-B as a data source.	0 1
ADS-B fault flag	ADS-B data corresponds with TIS-B data TIS-B data should be used in preference to ADS-B data.	0 1
Flight ID Flag	Optional information is not present. Optional information is present.	0 1
Target identifier	Either aircraft address (24-bit ICAO address) or a special identifier.	
Latitude	Encoded as an offset from the reference position (see clause 5.2.8).	
Longitude	Encoded as an offset from the reference position (see clause 5.2.8).	
Ground track	See ground track encoding in table 5.12.	
Ground speed	See ground speed encoding in table 5.14.	
Time Stamp (relative)	See table 5.47.	
Flight ID type	See table 5.47.	
Callsign	See table 5.47.	
(See table 5.11)		
Registration marking (tail number)	See table 5.47.	
Aircraft category	See table 5.47.	
NOTE: This is code defined by the ground system. It is unique in the TIV at any time. The first part of the identification could be the Mode A code or the tracker identification for that target followed by a unique number allocated by the ground system.		

5.2.7 Ground vehicle target messages (ground TIV)

Requirement reference	
5.2.7.1	The ground vehicle target message (ground TIV) shall be encoded as defined in table 5.50.
5.2.7.2	Fields in the ground vehicle target message (ground TIV) shall be encoded as defined in table 5.51.

Table 5.50: Vehicle target message (ground TIV) bit encoding

Description	Octet	Bit number							
		8	7	6	5	4	3	2	1
udid, ucd	5	0	0	0	0	0	1	1	1
TIS-B message ID (tmi) TIV ID (tivid)	n	tid ₁	tivid ₃	tivid ₂	tivid ₁	tmi ₄	tmi ₃	tmi ₂	tmi ₁
target identifier (tid)	n + 1	tid ₉	tid ₈	tid ₇	tid ₆	tid ₅	tid ₄	tid ₃	tid ₂
ADS-B fault flag (adsff)	n + 2	tag ₅	tag ₄	tag ₃	tag ₂	tag ₁	adsff	tid ₁₁	tid ₁₀
time stamp(tag) latitude (rlat)	n + 3	rlat ₇	rlat ₆	rlat ₅	rlat ₄	rlat ₃	rlat ₂	rlat ₁	tag ₆
	n + 4	rlat ₁₅	rlat ₁₄	rlat ₁₃	rlat ₁₂	rlat ₁₁	rlat ₁₀	rlat ₉	rlat ₈
longitude (rlg)	n + 5	rlg ₃	rlg ₂	rlg ₁	rlat ₂₀	rlat ₁₉	rlat ₁₈	rlat ₁₇	rlat ₁₆
	n + 6	rlg ₁₁	rlg ₁₀	rlg ₉	rlg ₈	rlg ₇	rlg ₆	rlg ₅	rlg ₄
	n + 7	rlg ₁₉	rlg ₁₈	rlg ₁₇	rlg ₁₆	rlg ₁₅	rlg ₁₄	rlg ₁₃	rlg ₁₂
ground track (gtk)	n + 8	gtk ₇	gtk ₆	gtk ₅	gtk ₄	gtk ₃	gtk ₂	gtk ₁	rlg ₂₀
ground speed (gsp)	n + 9	gsp ₇	gsp ₆	gsp ₅	gsp ₄	gsp ₃	gsp ₂	gsp ₁	gtk ₈

Table 5.51: Ground vehicle target message (ground TIV) field encoding

Data field	Definition	Encoded value
TIS-B message ID	See table 5.43.	3
TIV ID	Identifies TIV for ground stations configured to transmit more than one TIV.	0 - 7
Target identifier	Unique 11-bit code allocated by ground systems to vehicle target.	
ADS-B fault flag	ADS-B data corresponds with TIS-B data TIS-B data should be used in preference to ADS-B data.	0 1
Time Stamp	See table 5.47.	
Latitude	Encoded as an offset from the reference position (see clause 5.2.8).	
Longitude	Encoded as an offset from the reference position (see clause 5.2.8).	
Ground speed	See ground speed encoding in table 5.14.	
Ground track	See ground track encoding in table 5.12.	

5.2.8 TIS-B offset encoding

Requirement reference	
5.2.8.1	A fixed (virtual) reference position shall be chosen that is no more than 240 NM away from the centre of the TIV.
5.2.8.2	The TIV vertex and target latitude and longitude positions shall be encoded as offsets from the reference position by subtracting the coordinates of the fixed reference position from those of the vertex or target position as defined in table 5.53.
5.2.8.3	The TIV vertex and target longitude offsets from the reference position shall be multiplied by the function corr(lat) as defined in table 5.52, where lat = RND(latitude) is the vertex or target latitude rounded down to the nearest half degree.

Table 5.52: Values for scaling function $\text{corr}(\text{lat})$ used to encode target longitude

lat	corr	lat	corr	lat	corr	lat	corr	lat	corr	lat	corr
0	8 175	15	7 878	30	7 044	45	5 730	60	4 026	75	2 047
0,5	8 174	15,5	7 858	30,5	7 007	45,5	5 679	60,5	3 963	75,5	1 978
1	8 172	16	7 838	31	6 970	46	5 627	61	3 901	76	1 908
1,5	8 170	16,5	7 818	31,5	6 933	46,5	5 575	61,5	3 838	76,5	1 839
2	8 167	17	7 797	32	6 895	47	5 523	62	3 775	77	1 769
2,5	8 164	17,5	7 775	32,5	6 856	47,5	5 470	62,5	3 711	77,5	1 700
3	8 160	18	7 753	33	6 817	48	5 417	63	3 648	78	1 630
3,5	8 155	18,5	7 730	33,5	6 777	48,5	5 363	63,5	3 584	78,5	1 560
4	8 150	19	7 706	34	6 737	49	5 309	64	3 519	79	1 490
4,5	8 144	19,5	7 682	34,5	6 697	49,5	5 255	64,5	3 455	79,5	1 420
5	8 137	20	7 657	35	6 655	50	5 200	65	3 390	80	1 349
5,5	8 130	20,5	7 632	35,5	6 614	50,5	5 145	65,5	3 325	80,5	1 279
6	8 122	21	7 606	36	6 572	51	5 089	66	3 260	81	1 208
6,5	8 114	21,5	7 580	36,5	6 529	51,5	5 033	66,5	3 194	81,5	1 138
7	8 105	22	7 553	37	6 486	52	4 977	67	3 128	82	1 067
7,5	8 095	22,5	7 525	37,5	6 442	52,5	4 920	67,5	3 062	82,5	996
8	8 085	23	7 497	38	6 398	53	4 863	68	2 996	83	925
8,5	8 074	23,5	7 468	38,5	6 353	53,5	4 805	68,5	2 930	83,5	855
9	8 063	24	7 439	39	6 308	54	4 747	69	2 863	84	784
9,5	8 051	24,5	7 409	39,5	6 262	54,5	4 689	69,5	2 796	84,5	712
10	8 038	25	7 379	40	6 216	55	4 630	70	2 729	85	641
10,5	8 025	25,5	7 348	40,5	6 170	55,5	4 571	70,5	2 662	85,5	570
11	8 011	26	7 316	41	6 123	56	4 512	71	2 594	86	499
11,5	7 996	26,5	7 284	41,5	6 075	56,5	4 452	71,5	2 526	86,5	428
12	7 981	27	7 251	42	6 027	57	4 392	72	2 458	87	357
12,5	7 965	27,5	7 218	42,5	5 979	57,5	4 332	72,5	2 390	87,5	285
13	7 949	28	7 184	43	5 930	58	4 271	73	2 322	88	214
13,5	7 932	28,5	7 150	43,5	5 881	58,5	4 210	73,5	2 253	88,5	182
14	7 915	29	7 115	44	5 831	59	4 149	74	2 185	89	182
14,5	7 896	29,5	7 080	44,5	5 781	59,5	4 088	74,5	2 116	89,5	182

Table 5.53: Definition of offset encoding fields

Data Field	Definition	Encoded Value
Vertex latitude	Dlat = vertex latitude - reference latitude; Dlat is in degrees	
	For Dlat between -4 and $-(1+1/15)$ degrees: Encoded vertex latitude = $Dlat \times 15 + 60$ (Dlat has an increment of 1/15 of a degree or 4 NM; range from -240 NM to -64 NM)	0 to 44
	For Dlat between -1 and $-(1/3 + 1/60)$ degrees: Encoded vertex latitude = $Dlat \times 60 + 105$ (Dlat has an increment of 1/60 of a degree or 1 NM; range from -60 NM to -21 NM)	45 to 84
	For Dlat between $-1/3$ and $+1/3$ degrees: Encoded vertex latitude = $Dlat \times 120 + 125$ (Dlat has an increment of 1/120 of a degree or 0.5 NM; range from -20 NM to +20 NM)	85 to 165
	For Dlat between $(1/3 + 1/60)$ and +1 degrees: Encoded vertex latitude = $Dlat \times 60 + 145$ (Dlat has an increment of 1/60 of a degree or 1 NM; range from +21 NM to +60 NM)	166 to 205
	For Dlat between $(1+1/15)$ and +4 degrees: Encoded vertex latitude = $Dlat \times 15 + 190$ (Dlat has an increment of 1/15 of a degree or 4 NM; range from +64 NM to +240 NM)	206 to 250
	Unused	251 to 255
Vertex longitude	Dlon = vertex longitude - reference longitude; Dlon is in degrees	
	To encode a longitude offset in degrees, first convert to an offset in nautical miles (NM) (using the known latitude) in order to know which of the following encodings apply. Then perform the encoding with Dlon in degrees.	
	For Dlon (converted to NM) between -240 NM and -64 NM: Encoded vertex longitude = $INT(Dlon \times corr(vertex\ latitude) / 545 + 60)$ (increment and range in degrees depends on latitude: increment in NM is 4 NM or 1/15 of a degree at equator; range is between -4 and $-(1+1/15)$ degrees at equator; range is between -180 degrees and -48 degrees near the poles).	0 to 44
	For Dlon (converted to NM) between -60 NM and -21 NM: Encoded vertex longitude = $INT(Dlon \times corr(vertex\ latitude) \times 4 / 545 + 105)$ (increment and range in degrees depends on latitude: increment in NM is 1 NM or 1/60 of a degree at equator; range is between -1 and $-(1/3 + 1/60)$ degrees at equator; range is between -45 degrees and -15.75 degrees near the poles).	45 to 84
	For Dlon (converted to NM) between -20 NM and +20 NM: Encoded vertex longitude = $INT(Dlon \times corr(vertex\ latitude) \times 8 / 545 + 125)$ (increment and range in degrees depends on latitude: increment in NM is 0.5 NM or 1/120 of a degree at equator; range is between $-1/3$ and $+1/3$ degrees at equator; range is between -15 degrees and +15 degrees near the poles).	85 to 165
	For Dlon (converted to NM) between +21 NM and +60 NM: Encoded vertex longitude = $INT(Dlon \times corr(vertex\ latitude) \times 4 / 545 + 145)$ (increment and range in degrees depends on latitude: increment in NM is 1 NM or 1/60 of a degree at equator; range is between $(1/3 + 1/60)$ and +1 degrees at equator; range is between +15.75 degrees and +45 degrees near the poles).	166 to 205
For Dlon (converted to NM) between +64 NM and +240 NM: Encoded vertex longitude = $INT(Dlon \times corr(vertex\ latitude) / 545 + 190)$ (increment and range in degrees depends on latitude: increment in NM is 4 NM or 1/15 of a degree at equator; range is between $(1+1/15)$ and +4 degrees at equator; range is between +48 degrees and +180 degrees near the poles).	206 to 250	

Data Field	Definition	Encoded Value
	Unused	251 to 255
Airborne target latitude	<p>Dtlat = target latitude - reference latitude; Dtlat is in degrees</p> <p>For Dtlat between -4 degrees and +4 degrees: Encoded target latitude = $Dtlat \times 8\,175 + 32\,700$ (Dtlat has an increment of 1/8175 of a degree; target resolution ± 7 m; range from -240 NM to +240 NM).</p> <p>Unused</p>	<p>0 to 65 400</p> <p>65 401 to 65 536</p>
Airborne target longitude	<p>Dtlon = target longitude - reference longitude; Dtlon is in degrees</p> <p>For Dtlon (converted to NM) between -240 NM and +240 NM: Encoded target longitude = $INT(Dtlon \times \text{corr}(\text{target latitude}) + 32\,700)$ (Dtlon has an increment of 1/8175 of a degree at the equator; target resolution ± 7 m; range in degrees depends on latitude: range is between -4 degrees and +4 degrees at the equator; range is between -180 degrees and +180 degrees near the poles).</p> <p>Unused</p>	<p>0 to 65 400</p> <p>65 401 to 65 536</p>
Ground target latitude	<p>Dglat = target latitude - reference latitude; Dglat is in degrees</p> <p>For Dglat between -4 degrees and +4 degrees: Encoded target latitude = $Dglat \times 130\,800 + 523\,200$ (Dglat has an increment of 1/130 800 of a degree; target resolution ± 0.45 m; range from -240 NM to +240 NM).</p> <p>Unused</p>	<p>0 to 1 046 400</p> <p>1 046 401 to 1 048 575</p>
Ground target longitude	<p>Dglon = target longitude - reference longitude; Dglon is in degrees</p> <p>For Dglon (converted to NM) between -240 NM and +240 NM: Encoded target longitude = $INT(Dglon \times \text{corr}(\text{target latitude}) \times 16 + 523\,200)$ (Dglon has an increment of 1/130 800 of a degree at the equator; target resolution ± 0.45 m; range in degrees depends on latitude: range is between -4 degrees and +4 degrees at the equator; range is between -180 degrees and +180 degrees near the poles).</p> <p>Unused</p>	<p>0 to 1 046 400</p> <p>1 046 401 to 1 048 575</p>

5.3 Requirements for FIS-B

5.3.1 Message format

Requirement reference	
5.3.1.1	A FIS-B message shall be sent in a DLS UDATA DLPDU burst of type UINFO as described clause 5.3 of EN 301 842-2 [5].
5.3.1.2	To indicate a FIS-B service, the UDATA ID (udid) field shall be set to "00001" to indicate that a FIS-B service is applied (see clause 5.3.1.3 of EN 301 842-2 [5]).
5.3.1.3	The FIS-B data shall be placed in the information field of the VDL Mode 4 burst.
5.3.1.4	The information field of each FIS-B burst shall start with a FIS-B message identifier, as defined in table 5.54.
5.3.1.5	To indicate a FIS-B message identifier greater than 14, bits 1 to 4 of octet 6 shall be set to 15, and a further 4 bits of fmi1 shall be inserted starting in bit 5 of octet 6 and ending in bit 8 of octet 6, so that $fmi = 15 + fmi1$.
5.3.1.6	Each FIS-B message shall use either: <ul style="list-style-type: none"> • a reservation ID (rid) equal to 1, with the burst appended by a null reservation field as defined in clause 5.2.9 of EN 301 842-2 [5]; or • a reservation ID (rid) equal to 0 and an extended reservation ID (erid) equal to 00000binary, with the burst appended by a response reservation field as defined in clause 5.2.18 of EN 301 842-2 [5], with address type field equal to 7; • a reservation ID (rid) equal to 1, with the burst appended by a periodic broadcast reservation field as defined in clause 5.2.10 of EN 301 842-2 [5]; • a reservation ID (rid) equal to 0, with the burst appended by an incremental broadcast reservation field as defined in clause 5.2.11 of EN 301 842-2 [5]; • a reservation ID (rid) equal to 1, with the burst appended by a combined periodic broadcast and incremental broadcast reservation field as defined in clause 5.2.12 of EN 301 842-2 [5]; or • a reservation ID (rid) equal to 0, with the burst appended by a unicast reservation field with $sdf=1$ as defined in clause 5.2.14 of EN 301 842-2 [5]; or • a reservation ID (rid) equal to 0, with the burst appended by a second frame reservation field as defined in clause 5.2.17 of EN 301 842-2 [5]; or • a reservation ID (rid) equal to 0, with the burst appended by a superframe reservation field as defined in clause 5.2.17 of EN 301 842-2 [5].

Table 5.54: FIS-B message identifier encoding

Message	FIS-B Message ID Encoded value	4-bit Message ID Extension (fmi1) Encoded value
METAR	0	not present
ATIS	1	not present
RCN	2	not present
SIGMET	3	not present
SPECI	4	not present
REPORT REQUEST	5	not present
TSA	6	not present
Reserved for future use	7 - 14	not present
Available for future use with 4-bit extension	15	0 - 15

5.3.2 Meteorological Aerodrome Report (METAR) message

Requirement reference	
5.3.2.1	The METAR message shall be encoded as defined in table 5.55.
5.3.2.2	METAR reports shall be transmitted once during each update period.
5.3.2.3	Fields in the METAR report shall be encoded as defined in table 5.56.
5.3.2.4	If a TREND report is contained in the message, it shall always be included before the free text message.
5.3.2.5	If a TREND report is present, its end shall be signalled by the ASCII code "100100", corresponding to the character "\$".
5.3.2.6	The "\$" character shall be excluded from any FIS-B message.
5.3.2.7	ICAO Weather codes shall be encoded as defined in table 5.57.
5.3.2.8	The CAVOK flag shall indicate the CAVOK condition.
5.3.2.9	When the CAVOK flag is set to "1", the fields for visibility (mas, masd, mis, misd), the 3 possible present weather fields (pw), the 4 possible cloud coverage fields (cc, ch, cty), the cloud number flag (cno), and the present weather flag (pwf) shall not be sent.

Table 5.55: METAR message bit encoding

Description	Octet	Bit number							
		8	7	6	5	4	3	2	1
	5	0	0	0	0	1	1	1	1
FIS-B message ID (fmi) FIS-B version ID (vers)	6	vers ₄	vers ₃	vers ₂	vers ₁	fmi ₄	fmi ₃	fmi ₂	fmi ₁
message edition (med) local ID (locl)	7	locl ₅	locl ₄	locl ₃	locl ₂	locl ₁	med ₃	med ₂	med ₁
	8	locl ₁₃	locl ₁₂	locl ₁₁	locl ₁₀	locl ₉	locl ₈	locl ₇	locl ₆
date (date)	9	date ₁	locl ₂₀	locl ₁₉	locl ₁₈	locl ₁₇	locl ₁₆	locl ₁₅	locl ₁₄
time (ti)	10	ti ₄	ti ₃	ti ₂	ti ₁	date ₅	date ₄	date ₃	date ₂
wind direction (wdi)	11	wdi ₁	ti ₁₁	ti ₁₀	ti ₉	ti ₈	ti ₇	ti ₆	ti ₅
wind speed (wsp)	12	wsp ₃	wsp ₂	wsp ₁	wdi ₆	wdi ₅	wdi ₄	wdi ₃	wdi ₂
free text flag (ftxt) max wind flag (mxw) CAVOK flag (cav) TREND report flag (trd)	13	trd	cav	mxw	ftxt	wsp ₇	wsp ₆	wsp ₅	wsp ₄
present weather flag (pwf) recent weather flag (rwf) QFE flag (qfef) temperature (tem)	14	tem ₃	tem ₂	tem ₁	qfef	rwf ₂	rwf ₁	pwf ₂	pwf ₁
dew point temperature (dew)	15	dew ₃	dew ₂	dew ₁	tem ₈	tem ₇	tem ₆	tem ₅	tem ₄
QNH (qnh)	16	qnh ₃	qnh ₂	qnh ₁	dew ₈	dew ₇	dew ₆	dew ₅	dew ₄
wind shear flag (wsf) sea flag (ssf) variable wind direction to (vdit)	17	vdi ₁	ssf	wsf	qnh ₈	qnh ₇	qnh ₆	qnh ₅	qnh ₄
variable wind direction from (vdif)	18	vdif ₃	vdif ₂	vdif ₁	vdi ₆	vdi ₅	vdi ₄	vdi ₃	vdi ₂
wind gust indicator (wgi)	19	wgi ₅	wgi ₄	wgi ₃	wgi ₂	wgi ₁	vdif ₆	vdif ₅	vdif ₄
minimum visibility (mis)	20	mis ₆	mis ₅	mis ₄	mis ₃	mis ₂	mis ₁	wgi ₇	wgi ₆
minimum visibility direction (misd) maximum visibility (mas)	21	mas ₅	mas ₄	mas ₃	mas ₂	mas ₁	misd ₃	misd ₂	misd ₁
maximum visibility direction (masd) present weather (pw)	22	pw ₄	pw ₃	pw ₂	pw ₁	masd ₃	masd ₂	masd ₁	mas ₆
cloud no. flag (cno) cloud coverage (cc)	23	cc ₃	cc ₂	cc ₁	cno ₂	cno ₁	pw ₇	pw ₆	pw ₅
cloud height (ch)	24	ch ₈	ch ₇	ch ₆	ch ₅	ch ₄	ch ₃	ch ₂	ch ₁
cloud type (cty) QFE (qfe)	25	qfe ₆	qfe ₅	qfe ₄	qfe ₃	qfe ₂	qfe ₁	cty ₂	cty ₁
recent weather (rw)	26	rw ₆	rw ₅	rw ₄	rw ₃	rw ₂	rw ₁	qfe ₈	qfe ₇
wind shear (ws)	27	ws ₇	ws ₆	ws ₅	ws ₄	ws ₃	ws ₂	ws ₁	rw ₇
sea-surface temperature (sst) state of the sea (ss)	29	ss ₁	sst ₆	sst ₅	sst ₄	sst ₃	sst ₂	sst ₁	ws ₈
free text message (txt)	30	txt ₅	txt ₄	txt ₃	txt ₂	txt ₁	ss ₄	ss ₃	ss ₂
	31	txt _j	txt _{j-1}	txt _{j-2}	txt ₉	txt ₈	txt ₇	txt ₆

..... Denotes variable length field

Table 5.56: METAR message field encoding

Data field	Definition	Encoded value	Decoded value (if different)
FIS-B Message ID	See table 5.54	0	
Version ID	FIS-B as defined in the present document Reserved for future use	0 1 to 15	
Message edition	Edition of the METAR message (increments when message changes) A, B, C, D, E, F, G, H	0 to 7	
Local ID	ICAO airport designator 4 Letter Code, A to Z. Each letter encoded as a 5 bit binary A B C ↓ Y Z Unused	00001 00010 00011 ↓ 11001 11010 11011 to 11111	
Date	Unknown 1 2 3 ↓ 30 31	0 1 2 3 ↓ 30 31	
Time (minutes)	Unknown $0 \leq \text{time} < 1$ $1 \leq \text{time} < 2$ $2 \leq \text{time} < 3$ $3 \leq \text{time} < 4$ ↓ $1\ 438 \leq \text{time} < 1\ 439$ $1\ 439 \leq \text{time} < 1\ 440$ Unused	0 1 2 3 4 ↓ 1 439 1 440 1 441 to 2 047	0 1 2 3 1 438 1 439
Wind Direction (°)	Unknown $355 \leq \text{heading} < 5$ $5 \leq \text{heading} < 15$ $15 \leq \text{heading} < 25$ $25 \leq \text{heading} < 35$ ↓ $315 \leq \text{heading} < 325$ $325 \leq \text{heading} < 335$ $335 \leq \text{heading} < 345$ $345 \leq \text{heading} < 355$ Unused	0 1 2 3 4 ↓ 33 34 35 36 37 to 63	0 10 20 30 ↓ 320 330 340 350
Wind Speed (kts)	Unknown $0 < \text{speed} < 0,5$ $0,5 \leq \text{speed} < 1,5$ $1,5 \leq \text{speed} < 2,5$ $2,5 \leq \text{speed} < 3,5$ ↓ $96,5 \leq \text{speed} < 97,5$ $97,5 \leq \text{speed} < 98,5$ $98,5 \leq \text{speed} < 99,5$ $99,5 \leq \text{speed} < 100,5$ $100,5 \leq \text{speed}$ Unused	0 1 2 3 4 ↓ 98 99 100 101 102 103 to 127	0 1 2 3 ↓ 97 98 99 100

Data field	Definition	Encoded value	Decoded value (if different)
Free text flag (ftxt)	Refers to following field; Free text in the free text field. This flag does not affect the existence of a TREND report in the free text field. None Message	0 1	
Max wind flag	Refers to following field; Wind Gust Indicator None Gusts present	0 1	
CAVOK flag	Refers to following field; Visibility (mas, masd, mis, misd), the 3 possible present weather fields (pw) and the 4 possible cloud coverage characteristics fields (cc, ch, cty), the cloud number flag (cno) and the present weather flag (pwf). Under CAVOK conditions these will not be sent. No CAVOK CAVOK	0 1	
TREND flag	No TREND report TREND report present	0 1	
Present weather flag	Number of present weather fields to follow (max 3) Refers to following field; Present weather 1 weather field included 2 weather fields included 3 weather fields included reserved for future use	0 1 2 3	
Recent weather flag	Number of recent weather fields to follow (max 3) Refers to following field; Recent weather 1 weather field included 2 weather fields included 3 weather fields included reserved for future use	0 1 2 3	
QFE flag	Present Not present	0 1	
Temperature (°C)	Unknown -80 < temp ≤ -79 -79 < temp ≤ -78 -78 < temp ≤ -77 ↓ -1 < temp ≤ 0 0 < temp ≤ 1 1 < temp ≤ 2 ↓ 59 < temp ≤ 60 60 < temp Unused	0 1 2 3 ↓ 80 81 82 ↓ 140 141 142 to 255	-79 -78 -77 ↓ 0 1 2 ↓ 60
Dew point (°C)	As for temperature		
QNH (hPa)	Unknown 850 ≤ QNH < 851 851 ≤ QNH < 852 852 ≤ QNH < 853 ↓ 1 097 ≤ QNH < 1 098 1 098 ≤ QNH < 1 099 1 099 ≤ QNH < 1 100 1 100 ≤ QNH < 1 101 Unused	0 1 2 3 ↓ 248 249 250 251 252 to 255	850 851 852 ↓ 1 097 1 098 1 099 1 100

Data field	Definition	Encoded value	Decoded value (if different)
Sea Flag	Refers to following fields: state of the sea (ss) and sea temperature (sst) Present Not present	0 1	
Variable wind direction to (degrees)	Unknown 355 ≤ variable < 5 5 ≤ variable < 15 15 ≤ variable < 25 25 ≤ variable < 35 ↓ 315 ≤ variable < 325 325 ≤ variable < 335 335 ≤ variable < 345 345 ≤ variable < 355 Unused	0 1 2 3 4 ↓ 33 34 35 36 37 to 63	 0 10 20 30 ↓ 320 330 340 350
Variable wind direction from (degrees)	As above		
Wind Gust Indicator	As for wind speed		
Minimum visibility (metres)	Unknown 0 ≤ visibility < 100 100 ≤ visibility < 150 150 ≤ visibility < 200 200 ≤ visibility < 250 ↓ 700 ≤ visibility < 750 750 ≤ visibility < 800 800 ≤ visibility < 900 900 ≤ visibility < 1 000 ↓ 6 000 ≤ visibility < 7 000 7 000 ≤ visibility < 8 000 8 000 ≤ visibility < 9 000 9 000 ≤ visibility < 10 000 10 000 ≤ visibility < 11 000 Unused	0 1 2 3 4 ↓ 14 15 16 17 ↓ 41 42 43 44 45 46 to 63	 50 100 150 200 ↓ 700 750 800 900 ↓ 6 000 7 000 8 000 9 000 10 000
Minimum visibility direction	North North East East South East South South West West North West	0 1 2 3 4 5 6 7	0 1 2 3 4 5 6 7
Maximum visibility (metres)	As for minimum visibility		
Maximum visibility direction	As for minimum visibility direction		
Present weather	See weather codes in table 5.57 Encoded values not specified in table 5.57 are unused		
Cloud no. flag	Number of cloud fields to follow (max 4) Referred to following fields; Cloud coverage, Cloud Height, Cloud Type 1 2 3 4	0 1 2 3	

Data field	Definition	Encoded value	Decoded value (if different)
Cloud coverage	Unknown Few Scattered Broken Overcast Sky clear Unused	0 1 2 3 4 5 6 to 7	
Cloud height (m)	0 ≤ heading < 60 60 ≤ heading < 90 90 ≤ heading < 120 120 ≤ heading < 150 150 ≤ heading < 180 ↓ 2 910 ≤ heading < 2 940 2 940 ≤ heading < 2 970 2 970 ≤ heading < 3 000 3 000 ≤ heading < 3 300 ↓ 19 800 ≤ heading < 20 100 20 100 ≤ heading < 20 400 Unused	0 1 2 3 4 ↓ 96 97 98 99 ↓ 155 156 157 to 255	30 60 90 120 150 ↓ 2 910 2 940 2 970 3 000 ↓ 19 800 20 100
Cloud type	No clouds of concern Cumulonimbus Towering cumulus Future use	0 1 2 3	
QFE (hPa)	Unknown 850 ≤ QFE < 851 851 ≤ QFE < 852 852 ≤ QFE < 853 ↓ 1 097 ≤ QFE < 1 098 1 098 ≤ QFE < 1 099 1 099 ≤ QFE < 1 100 1 100 ≤ QFE < 1 101 Unused	0 1 2 3 ↓ 248 249 250 251 252 to 255	850 851 852 ↓ 1 097 1 098 1 099 1 100
Recent weather	See weather codes in table 5.57 Encoded values not specified in table 5.57 are unused		
Sea-surface temperature (°C)	Unknown -10 ≤ SST < -9 -9 ≤ SST < -8 -8 ≤ SST < -7 ↓ 36 ≤ SST < 37 37 ≤ SST < 38 38 ≤ SST < 39 39 ≤ SST < 40 40 ≤ SST Unused	0 1 2 3 ↓ 47 48 49 50 51 52 to 63	-10 -9 -8 ↓ 36 37 38 39 40

Data field	Definition	Encoded value	Decoded value (if different)
State of the sea	Unknown 0 1 2 3 4 5 6 7 8 9 Unused	0 1 2 3 4 5 6 7 8 9 10 11 to 15	
Free text message	Variable field length (6-bit converted ASCII characters) See table 5.57a		
NOTE: See WMO Publication No306, Manual on Codes Vol 1.1, Part A for interpretation.			

Table 5.57: Encoding for ICAO Weather codes

Explanation	Encoded Value
No precipitation during observation	
Fume - smoke	4
Dust haze	5
Rising dust and sand	7
Dust devil	8
Brune - mist	10
Mince fog - shallow fog	11
Mince fog	12
Thunderstorm	17
Funnel cloud	18
Recent drizzle	20
Recent rain	21
Recent snow	22
Recent rain and snow	23
Recent freezing rain	24
Recent showers	25
Recent snow showers	26
Recent grain(hail)	27
Recent thunderstorm	29
Sand or dust storm	30
Heavy sand storm	33
Low drifting snow	36
Blowing snow	38
Fog patches	40
Fog	42
Freezing fog	48
Precipitation during observation	
Drizzle	50
Heavy drizzle	54
Freezing drizzle	56
Heavy freezing drizzle	57
Rain	58
Heavy rain	64
Freezing rain	66
Heavy freezing rain	67
Rain and snow	68
Snow	70
Heavy snow	74
Snow grains	77
Ice pellets	79
Showers	80
Heavy showers	81
Showers of rain and snow	83
Snow showers	85
Soft hail	87
Hail	89
Thunderstorm	95
Thunderstorm with hail	96
Heavy thunderstorm	97

Table 5.57a: Free text 6-bit character encoding (converted from ASCII 8-bit)

First 32 characters			Last 32 characters		
Character	(Decimal)	Encoded Binary	Character	(Decimal)	Encoded Binary
@	0	000000	[space]	32	100000
A	1	000001	!	33	100001
B	2	000010	"	34	100010
C	3	000011	#	35	100011
D	4	000100	\$	36	100100
E	5	000101	%	37	100101
F	6	000110	&	38	100110
G	7	000111	'	39	100111
H	8	001000	(40	101000
I	9	001001)	41	101001
J	10	001010	*	42	101010
K	11	001011	+	43	101011
L	12	001100	,	44	101100
M	13	001101	-	45	101101
N	14	001110	.	46	101110
O	15	001111	/	47	101111
P	16	010000	0	48	110000
Q	17	010001	1	49	110001
R	18	010010	2	50	110010
S	19	010011	3	51	110011
T	20	010100	4	52	110100
U	21	010101	5	53	110101
V	22	010110	6	54	110110
W	23	010111	7	55	110111
X	24	011000	8	56	111000
Y	25	011001	9	57	111001
Z	26	011010	:	58	111010
[27	011011	;	59	111011
\	28	011100	<	60	111100
]	29	011101	=	61	111101
^	30	011110	>	62	111110
_	31	011111	?	63	111111

5.3.3 Special Observations and Reports (SPECI) message

Requirement reference	
5.3.3.1	The SPECI report shall be encoded as defined for the METAR message in table 5.55 and table 5.56, with the FIS-B message ID set to 4, and the message edition indicating the edition of the SPECI message.

5.3.4 Automatic Terminal Information Service (ATIS) message

Requirement reference	
5.3.4.1	The ATIS report shall be encoded as defined in table 5.58.
5.3.4.2	If a TREND report is contained in the message, it shall always be transmitted before the free text message.
5.3.4.3	If a TREND report is present, its end shall be signalled by the ASCII code "100100", corresponding to the character "\$".
5.3.4.4	The "\$" character shall be excluded from any FIS-B message.
5.3.4.5	Fields in the ATIS message shall be encoded as defined in table 5.59.
5.3.4.6	The CAVOK flag shall indicate the CAVOK condition.
5.3.4.7	When the CAVOK flag is set to "1", the fields for visibility (mas, masd, mis, misd), the 3 possible present weather fields (pw), the 4 possible cloud coverage fields (cc, ch, cty), the cloud number flag (cno), and the present weather flag (pwf) shall not be sent.

Table 5.58: ATIS message bit encoding

Description	Octet	Bit number							
		8	7	6	5	4	3	2	1
	5	0	0	0	0	1	1	1	1
FIS-B message ID (fmi) FIS-B version ID (vers) message edition (med)	6	vers ₄	vers ₃	vers ₂	vers ₁	fmi ₄	fmi ₃	fmi ₂	fmi ₁
local ID(locl)	7	locl ₅	locl ₄	locl ₃	locl ₂	locl ₁	med ₃	med ₂	med ₁
	8	locl ₁₃	locl ₁₂	locl ₁₁	locl ₁₀	locl ₉	locl ₈	locl ₇	locl ₆
date (date)	9	date ₁	locl ₂₀	locl ₁₉	locl ₁₈	locl ₁₇	locl ₁₆	locl ₁₅	locl ₁₄
time (ti)	10	ti ₄	ti ₃	ti ₂	ti ₁	date ₅	date ₄	date ₃	date ₂
holding delay (hd)	11	hd ₁	ti ₁₁	ti ₁₀	ti ₉	ti ₈	ti ₇	ti ₆	ti ₅
transition level (tran)	12	tran ₅	tran ₄	tran ₃	tran ₂	tran ₁	hd ₄	hd ₃	hd ₂
other op. activity flag (othf) other op. activity (oth) airport availability (aavl)	13	aavl ₃	aavl ₂	aavl ₁	oth ₃	oth ₂	oth ₁	othf	tran ₆
	14	aavl ₁₁	aavl ₁₀	aavl ₉	aavl ₈	aavl ₇	aavl ₆	aavl ₅	aavl ₄
wind direction (wdi) wind speed (wsp)	15	wsp ₁	wdi ₆	wdi ₅	wdi ₄	wdi ₃	wdi ₂	wdi ₁	aavl ₁₂
temperature (tem)	16	tem ₂	tem ₁	wsp ₇	wsp ₆	wsp ₅	wsp ₄	wsp ₃	wsp ₂
dew point (dew)	17	dew ₂	dew ₁	tem ₈	tem ₇	tem ₆	tem ₅	tem ₄	tem ₃
QNH (qnh)	18	qnh ₂	qnh ₁	dew ₈	dew ₇	dew ₆	dew ₅	dew ₄	dew ₃
free text flag (ftxt) max wind flag (mxw) CAVOK flag (cav)	19	mxw	ftxt	qnh ₈	qnh ₇	qnh ₆	qnh ₅	qnh ₄	qnh ₃
TREND report flag (trd) QFE flag (qfef) wind shear flag (ws) Present weather flag (pwf) Recent weather flag (rwf) variable wind direction to (vdit)	20	rwf ₂	rwf ₁	pwf ₂	pwf ₁	ws	qfef	trd	cav
variable wind direction from (vdif)	21	vdif ₂	vdif ₁	vdit ₆	vdit ₅	vdit ₄	vdit ₃	vdit ₂	vdit ₁
wind gust indicator (wgi)	22	wgi ₄	wgi ₃	wgi ₂	wgi ₁	vdif ₆	vdif ₅	vdif ₄	vdif ₃
Minimum visibility (mis)	23	mis ₅	mis ₄	mis ₃	mis ₂	mis ₁	wgi ₇	wgi ₆	wgi ₅
Minimum visibility direction (misd) Maximum visibility (mas)	24	mas ₄	mas ₃	mas ₂	mas ₁	misd ₃	misd ₂	misd ₁	mis ₆
Maximum visibility direction (masd) cloud no. flag (cno) cloud coverage (cc)	25	cc ₁	cno ₂	cno ₁	masd ₃	masd ₂	masd ₁	mas ₆	mas ₅
cloud height (ch)	26	ch ₆	ch ₅	ch ₄	ch ₃	ch ₂	ch ₁	cc ₃	cc ₂
cloud type (cty) present weather (pw)	27	pw ₄	pw ₃	pw ₂	pw ₁	cty ₂	cty ₁	ch ₈	ch ₇

Description	Octet	Bit number							
		8	7	6	5	4	3	2	1
recent weather (rw)	28	rw ₅	rw ₄	rw ₃	rw ₂	rw ₁	pw ₇	pw ₆	pw ₅
QFE (qfe)	29	qfe ₆	qfe ₅	qfe ₄	qfe ₃	qfe ₂	qfe ₁	rw ₇	rw ₆
free text message (txt)	30	txt ₆	txt ₅	txt ₄	txt ₃	txt ₂	txt ₁	qfe ₈	qfe ₇
	31	txt _j	txt _{j-1}	txt _{j-2}	txt ₁₀	txt ₉	txt ₈	txt ₇

! ! [Denotes variable length field]

Table 5.59: ATIS message field encoding

Data field	Definition	Encoded value	Decoded value (if different)
FIS-B Message ID	See table 5.54.	1	
Version ID	FIS-B as defined in the present document Reserved for future use.	0 1 to 15	
Message edition	See definition in table 5.56.		
Local ID	See definition in table 5.56.		
Date	See definition in table 5.56.		
Time	See definition in table 5.56.		
Holding Delay	No Delay. 5 min 10 min 15 min 20 min 25 min 30 min 35 min 40 min 45 min 50 min 55 min 60 min Unused Unused Unknown Delay.	0 1 2 3 4 5 6 7 8 9 10 11 12 13 14 15	
Transition level	Unknown. 0 5 10 15 ↓ 285 290 295 300 Reserved for future use.	0 1 2 3 4 ↓ 58 59 60 61 62 to 63	
Other operational activity flag	Present. Not present.	0 1	
Other operational activity	Reserved for future use. (e.g. bird activity).	0 to 7	
Airport availability	Bits 1 to 11: as for Time in table 5.56. Bit 12: Open. Closed.	1 0	
Wind Direction (°)	See definition in table 5.56.		
Wind Speed (kts)	See definition in table 5.56.		
Temperature (degrees)	See definition in table 5.56.		
Dew point (degrees)	As for temperature.		
QNH	See definition in table 5.56.		

Data field	Definition	Encoded value	Decoded value (if different)
Free text flag	Refers to following field: Free text in the free text field. This flag does not affect the existence of a TREND report in the free text field. None. Message.	0 1	
Max wind flag	Refers to following field: Wind Gust Indicator. None. Gusts present.	0 1	
CAVOK flag	Refers to following fields: visibility (mas, masd, mis, misd), the 3 possible present weather fields (pw), the 4 possible cloud coverage fields (cc, ch, cty), the cloud number flag (cno), and the present weather flag (pwf). Under CAVOK conditions these will not be sent. No CAVOK. CAVOK.	0 1	
TREND flag	None. Message.	0 1	
QFE flag	Present. Not present.	0 1	
Present weather flag	See definition in table 5.56.		
Recent weather flag	See definition in table 5.56.		
Variable wind directions to (degrees)	See definition in table 5.56.		
Variable wind directions from (degrees)	As above.		
Wind gust indicator	As for wind speed.		
Minimum visibility (metres)	See definition in table 5.56.		
Minimum visibility direction	See definition in table 5.56.		
Maximum visibility (metres)	As for minimum visibility.		
Maximum visibility direction	As for minimum visibility direction.		
Cloud no. flag	See definition in table 5.56.		
Cloud coverage	See definition in table 5.56.		
Cloud Height (m)	See definition in table 5.56.		
Cloud Type	See definition in table 5.56.		
Present weather	See weather codes in table 5.57. Encoded values not specified in table 5.57 are unused.		
Recent weather	See weather codes in table 5.57. Encoded values not specified in table 5.57 are unused.		
QFE	See definition in table 5.56.		
Free text message	Variable field length (6-bit converted ASCII characters). See table 5.57a.		

5.3.5 Runway Condition (RCN) message

Requirement reference	
5.3.5.1	The RCN message shall be encoded as defined in table 5.60.
5.3.5.2	Fields in the RCN message shall be encoded as defined in table 5.61.

Table 5.60: RCN message bit encoding

Description	Octet	Bit number							
		8	7	6	5	4	3	2	1
	5	0	0	0	0	1	1	1	1
FIS-B message ID (fmi)	6	vers ₄	vers ₃	vers ₂	vers ₁	fmi ₄	fmi ₃	fmi ₂	fmi ₁
FIS-B version ID (vers)									
message edition (med)	7	locl ₅	locl ₄	locl ₃	locl ₂	locl ₁	med ₃	med ₂	med ₁
local ID (locl)									
	8	locl ₁₃	locl ₁₂	locl ₁₁	locl ₁₀	locl ₉	locl ₈	locl ₇	locl ₆
date (date)	9	date ₁	locl ₂₀	locl ₁₉	locl ₁₈	locl ₁₇	locl ₁₆	locl ₁₅	locl ₁₄
time (ti)	10	ti ₄	ti ₃	ti ₂	ti ₁	date ₅	date ₄	date ₃	date ₂
braking action (brk)	11	brk ₁	ti ₁₁	ti ₁₀	ti ₉	ti ₈	ti ₇	ti ₆	ti ₅
runway ID (run)	12	run ₆	run ₅	run ₄	run ₃	run ₂	run ₁	brk ₃	brk ₂
Approach type flag (aptf)	13	apty ₄	apty ₃	apty ₂	apty ₁	aptf ₂	aptf ₁	run ₈	run ₇
Approach type (apty)									
reduced runway length (rrl)	14	rrl ₈	rrl ₇	rrl ₆	rrl ₅	rrl ₄	rrl ₃	rrl ₂	rrl ₁
reduced runway width (rrw)	15	rdp ₁	rrw ₇	rrw ₆	rrw ₅	rrw ₄	rrw ₃	rrw ₂	rrw ₁
runway deposits (rdp)									
runway contamination (rcon)	16	dod ₂	dod ₁	rcon ₃	rcon ₂	rcon ₁	rdp ₄	rdp ₃	rdp ₂
depth of deposit (dod)									
RVR touchdown (rvt)	17	rvt ₃	rvt ₂	rvt ₁	dod ₇	dod ₆	dod ₅	dod ₄	dod ₃
RVR midpoint (rvm)	18	rvm ₅	rvm ₄	rvm ₃	rvm ₂	rvm ₁	rvt ₆	rvt ₅	rvt ₄
RVR endpoint (rve)	19	rso ₁	rve ₆	rve ₅	rve ₄	rve ₃	rve ₂	rve ₁	rvm ₆
RVR source (rso)									
runway in use (rus)	20	ravl ₅	ravl ₄	ravl ₃	ravl ₂	ravl ₁	rus ₂	rus ₁	rso ₂
runway availability (ravl)									
wind shear	21	ws	ravl ₁₂	ravl ₁₁	ravl ₁₀	ravl ₉	ravl ₈	ravl ₇	ravl ₆

Table 5.61: RCN message field encoding

Data field	Definition	Encoded Value	Decoded value (if different)
FIS-B Message ID	See table 5.54.	2	
Version ID	FIS-B as defined in the present document. Reserved for future use.	0 1 to 15	
Message edition	See definition in table 5.56.		
Local ID	See definition in table 5.56.		
Date	See definition in table 5.56.	0	
Time	See definition in table 5.56.	0	
Braking action	Braking action not reported. Braking action: Poor. Braking action: Medium/Poor. Braking action: Medium. Braking action: Medium/Good. Braking action: Good. Figures unreliable. Unused.	0 1 2 3 4 5 6 7	
Runway ID	Bits 1 - 6: 01 - 36 Bits 7 - 8: Single runway. Left runway. Right runway. Centre runway.	0 - 35 0 1 2 3	
Approach type flag	1 approach field included. 2 approach field included. 3 approach field included. Unused.	0 1 2 3	

Data field	Definition	Encoded Value	Decoded value (if different)
Approach type	ILS CAT I ILS CAT II ILS CAT III VOR VOR/DME NDB Radar Vectoring. VDF MLS VISUAL Unused.	0 1 2 3 4 5 6 7 8 9 10 - 15	
Reduced runway length (metres)	Not reported. 0 ≤ length < 50. 50 ≤ length < 100. 100 ≤ length < 150. 150 ≤ length < 200. ↓ 6 300 ≤ length < 6 350. 6 350 ≤ length < 6 400. 6 400 ≤ length < 6 450. 6 450 ≤ length. Unused. Full length.	0 1 2 3 4 ↓ 127 128 129 130 131 to 254 255	 25 75 125 175 6 325 6 375 6 425
Reduced runway width (metres)	Not reported. 0 ≤ width < 1. 1 ≤ width < 2. 2 ≤ width < 3. 3 ≤ width < 4. ↓ 67 ≤ width < 68. 68 ≤ width < 69. 69 ≤ width < 70. 70 ≤ width. Unused. Full width.	0 1 2 3 4 ↓ 68 69 70 71 72 to 126 127	 1 2 3 4 68 69 70
Runway deposits	Clear and dry. Damp. Wet and water patches. Rime or frost covered. Dry snow. Wet snow. Slush. Ice. Compacted or rolled snow. Frozen ruts or ridges. Type of deposit not reported. Unused.	0 1 2 3 4 5 6 7 8 9 10 11 to 15	
Runway contamination	None. 10 % or less. 11 % to 25 %. 26 % to 50 %. 51 % to 100 %. Unused. Unused. Not reported.	0 1 2 3 4 5 6 7	

Data field	Definition	Encoded Value	Decoded value (if different)
Depth of Deposit	less than 1 mm.	0	
	1 mm	1	
	2 mm	2	
	3 mm	3	
	↓	↓	
	89 mm	89	
	90 mm	90	
	10 cm	91	
	15 cm	92	
	20 cm	93	
	↓	↓	
	35 cm	96	
	40 cm or more	97	
	Runway not operational due to snow, slush, ice, large drifts or runway clearance, and depth not reported.	98	
Depth deposit operationally not significant or not measurable.	99		
Unused.	100 to 127		
RVR - Touchdown (metres)	Not reported.	0	
	0 < RVR < 25.	1	0
	25 < RVR < 50.	2	25
	50 < RVR < 75.	3	50
	↓.	↓	
	350 < RVR < 375.	15	350
	375 < RVR < 400.	16	375
	400 < RVR < 450.	17	400
	450 < RVR < 500.	18	450
	↓	↓	
	700 < RVR < 750.	23	700
	750 < RVR < 800.	24	750
	800 < RVR < 900.	25	800
	900 < RVR < 1 000.	26	900
	↓	↓	
1 300 < RVR < 1 400.	30	1 300	
1 400 < RVR < 1 500.	31	1 400	
1 500 < RVR < 1 600.	32	1 500	
Unused.	33 to 63		
RVR - Midpoint	As for RVR - Touchdown.		
RVR - Endpoint	As for RVR - Touchdown.		
RVR source	Unknown.	0	
	Human Observer.	1	
	Instrumented RVR system (IRVR).	2	
	Reserved for future use.	3	
Runway in use	Yes - for arrivals.	0	
	Yes - for departures.	1	
	Yes - mixed operations.	2	
	No.	3	
Runway availability	Bits 1 to 11: as for Time in table 5.56.		
	Bit 12: Open.	1	
	Closed.	0	
Windshear	No.	0	
	Yes.	1	

5.3.6 SIGnificant METeorological Information (SIGMET) message

Requirement reference	
5.3.6.1	The SIGMET message shall be encoded as defined in table 5.62
5.3.6.2	The SIGMET message shall include a free text message encoded in the free text message field (txt) using 6 bit ASCII characters.
5.3.6.3	<p>The information contained within the free text portion of the SIGMET message shall include the following information detailed in abbreviated plain language using approved ICAO abbreviations:</p> <ul style="list-style-type: none"> • Application FIR: The name of the flight information region or control area for which the SIGMET message is issued shall be detailed; • Type of Information: This will detail whether the weather phenomenon is an observed or forecast condition. If the weather condition is an observed condition the time of observation shall be indicated in UTC; • Location and Level: This will give an indication, referring where possible to latitude and longitude and/or locations or geographic features known well internationally; • Movement and Speed: The movement or expected movement of the phenomenon shall be given with reference to one of the eight points of the compass and given in terms of kilometres per hour, knots per hour, or stationary; • Changes in Intensity: The free text shall indicate the changes in intensity of the weather condition expressing this in terms of intensifying, weakening or no change; • Additional Information: Additional information shall detail any further pertinent information to the weather phenomenon. This may also include an outlook providing information beyond the period for which the SIGMET is valid.
5.3.6.4	Fields within the SIGMET message shall be encoded as defined in table 5.63.

Table 5.62: SIGMET message bit encoding

Description	Octet	Bit number							
		8	7	6	5	4	3	2	1
	5	0	0	0	0	1	1	1	1
FIS-B message ID (fmi)	6	sqn ₄	sqn ₃	sqn ₂	sqn ₁	fmi ₄	fmi ₃	fmi ₂	fmi ₁
FIS-B sequence number (sqn)	7	loci ₅	loci ₄	loci ₃	loci ₂	loci ₁	med ₃	med ₂	med ₁
message edition (med)	8	loci ₁₃	loci ₁₂	loci ₁₁	loci ₁₀	loci ₉	loci ₈	loci ₇	loci ₆
location indicator (loci)	9	ori ₁	loci ₂₀	loci ₁₉	loci ₁₈	loci ₁₇	loci ₁₆	loci ₁₅	loci ₁₄
originator indicator (ori)	10	ori ₉	ori ₈	ori ₇	ori ₆	ori ₅	ori ₄	ori ₃	ori ₂
	11	ori ₁₇	ori ₁₆	ori ₁₅	ori ₁₄	ori ₁₃	ori ₁₂	ori ₁₁	ori ₁₀
date issued (di)	12	di ₅	di ₄	di ₃	di ₂	di ₁	ori ₂₀	ori ₁₉	ori ₁₈
time issued (ti)	13	ti ₈	ti ₇	ti ₆	ti ₅	ti ₄	ti ₃	ti ₂	ti ₁
date valid to (dvt)	14	dvt ₅	dvt ₄	dvt ₃	dvt ₂	dvt ₁	ti ₁₁	ti ₁₀	ti ₉
time valid to (tvt)	15	tvt ₈	tvt ₇	tvt ₆	tvt ₅	tvt ₄	tvt ₃	tvt ₂	tvt ₁
SIGMET flag (sfl) free text flag (ftxt) phenomenon / condition reported (crp)	14	crp ₃	crp ₂	crp ₁	ftxt	sfl	tvt ₁₁	tvt ₁₀	tvt ₉
free text message (txt)	15	txt ₆	txt ₅	txt ₄	txt ₃	txt ₂	txt ₁	crp ₅	crp ₄
	16	txt _j	txt _{j-1}	txt _{j-2}	txt ₁₀	txt ₉	txt ₈	txt ₇

..... [Denotes variable length field]

Table 5.63: SIGMET message field encoding

Data field	Definition	Encoded value
FIS-B Message ID	See table 5.54.	3
FIS-B sequence number	1 to 16.	0 to 15
Message edition	See definition in table 5.56.	
Location indicator	See definition for local ID in table 5.56.	
Originator indicator	WMO originator office encoded as ICAO aerodrome.	
Date issued	See definition in table 5.56.	
Time issued	See definition in table 5.56.	
Date valid to	See definition in table 5.56.	
Time valid to	See definition in table 5.56.	
Free text flag	None.	0
	Message.	1
SIGMET flag	Normal.	0
	Convective SIGMET.	1
Phenomenon / Condition reported	Condition reported in free text.	0
	Thunderstorm.	1
	Thunderstorm obscured.	2
	Thunderstorm embedded.	3
	Thunderstorm frequent.	4
	Thunderstorm squall line.	5
	Thunderstorm obscured with heavy hail.	6
	Thunderstorm embedded with heavy hail.	7
	Thunderstorm frequent with heavy hail.	8
	Thunderstorm squall line with heavy hail.	9
	Tropical cyclone.	10
	Freezing rain.	11
	Moderate turbulence.	12
	Severe turbulence.	13
	Severe icing.	14
	Severe icing due to freezing rain.	15
	Severe mountain waves.	16
Heavy dust storm.	17	
Heavy sand storm.	18	
Volcanic ash.	19	
Isolated cumulonimbus.	20	
Occasional cumulonimbus.	21	
Frequent cumulonimbus.	22	
Reserved for future use.	23 - 31	
Free text message	Variable field length (6-bit converted ASCII characters) See table 5.57a.	

5.3.7 Temporary Segregated Areas (TSA) message

Requirement reference	
5.3.7.1	The TSA message shall be encoded as defined in table 5.64 and either table 5.65 or table 5.66.
5.3.7.2	The fixed field defined in table 5.64 shall be sent in all TSA messages.
5.3.7.3	If the message is of type Control Zone, the octets defined in table 5.65 shall be appended to the fixed field at octet 10.
5.3.7.4	If the message is of type Restricted Area, Danger Area or Prohibited Area, the octets defined in table 5.66 shall be appended to the fixed field at octet 10.
5.3.7.5	Fields within the TSA message shall be encoded as defined in table 5.67.

Table 5.64: TSA message fixed field bit encoding

Description	Octet	Bit number							
		8	7	6	5	4	3	2	1
	5	0	0	0	0	1	1	1	1
FIS-B message ID (fmi) version ID (vers) message edition (med)	6	vers ₄	vers ₃	vers ₂	vers ₁	fmi ₄	fmi ₃	fmi ₂	fmi ₁
date (date)	7	date ₅	date ₄	date ₃	date ₂	date ₁	med ₃	med ₂	med ₁
time (ti)	8	ti ₈	ti ₇	ti ₆	ti ₅	ti ₄	ti ₃	ti ₂	ti ₁
Number of TSAs (NoT)	9	NoT ₅	NoT ₄	NoT ₃	NoT ₂	NoT ₁	ti ₁₁	ti ₁₀	ti ₉
Information field	10-n								

Table 5.65: TSA message bit encoding for area Control Zone

Description	Octet	Bit number							
		8	7	6	5	4	3	2	1
Type of Area (toa) Active flag (act) local ID (locl)	10	locl ₄	locl ₃	locl ₂	locl ₁	act ₁	toa ₃	toa ₂	toa ₁
	11	locl ₁₂	locl ₁₁	locl ₁₀	locl ₉	locl ₈	locl ₇	locl ₆	locl ₅
	12	locl ₂₀	locl ₁₉	locl ₁₈	locl ₁₇	locl ₁₆	locl ₁₅	locl ₁₄	locl ₁₃
supplement to local ID (sloc) active from/to date (actdat) active from/to time (actim) TWR frequency (freq)	13	actdat ₃	actdat ₂	actdat ₁	sloc ₅	sloc ₄	sloc ₃	sloc ₂	sloc ₁
	14	actim ₆	actim ₅	actim ₄	actim ₃	actim ₂	actim ₁	actdat ₅	actdat ₄
	15	freq ₃	freq ₂	freq ₁	actim ₁₁	actim ₁₀	actim ₉	actim ₈	actim ₇
	16	freq ₁₁	freq ₁₀	freq ₉	freq ₈	freq ₇	freq ₆	freq ₅	freq ₄
..... next TSA....	17-n								

Table 5.66: TSA message bit encoding for Restricted, Danger, or Prohibited area

Description	Octet	Bit number							
		8	7	6	5	4	3	2	1
Type of Area (toa) Active flag (act) state ID (stid) Area leap number (aln)	10	stid ₄	stid ₃	stid ₂	stid ₁	act ₁	toa ₃	toa ₂	toa ₁
	11	aln ₂	aln ₁	stid ₁₀	stid ₉	stid ₈	stid ₇	stid ₆	stid ₅
	12	aln ₁₀	aln ₉	aln ₈	aln ₇	aln ₆	aln ₅	aln ₄	aln ₃
Supplement to area leap number (saln)	13	saln ₅	saln ₄	saln ₃	saln ₂	saln ₁	aln ₁₃	aln ₁₂	aln ₁₁
active from/to date (actdat) active from/to time (actim)	14	actim ₃	actim ₂	actim ₁	actdat ₅	actdat ₄	actdat ₃	actdat ₂	actdat ₁
	15	actim ₁₁	actim ₁₀	actim ₉	actim ₈	actim ₇	actim ₆	actim ₅	actim ₄
..... next TSA....	16-n								

Table 5.67: TSA message field encoding

Data field	Definition	Encoded Value
FIS-B Message ID	See table 5.54.	6
Version ID	FIS-B as defined in the present document Reserved for future use.	0 1 to 15
Message edition	See definition in table 5.56.	
Local ID	See definition in table 5.56.	
Date	See definition in table 5.56.	
Time	See definition in table 5.56.	
Number of TSA"s	1 TSA 2 TSAs ↓ 32 TSAs	0 1 ↓ 31
Type of Area	Describes the type of TSA: Control zone. Restricted Area. Danger Area. Prohibited Area. Reserved for future use.	0 1 2 3 4 to 7
ACTIVE FLAG	Denotes whether the TSA is active or not (A TSA could be transmitted a certain time before it becomes active). Not Active. Active.	0 1
Supplement to local ID	Some control zones can have different extensions depending on neighbouring control zones being open or not. To distinguish between the different parts of the control zone referred to, a letter is added to the local ID, this letter corresponds to a certain part of the control zone. 1 Letter code A-Z encoded as a 5-bit binary. A B C ↓ Y Z	00001 00010 00011 ↓ 11001 11010
Active from/to date	If the TSA is not yet active (active flag set to 0) this field shows which date the area will become active. If the TSA is already active (active flag set to 1) this field shows which date the area will become not active. See date definition in table 5.56.	
Active from/to time	If the TSA is not yet active (active flag set to 0) this field shows which time the area will become active. If the TSA is already active (active flag set to 1) this field shows which time the area will become not active. See time definition in table 5.56.	
TWR frequency	The frequency used to contact TWR. Unknown. 108,000 108,025 108,050 ↓ 136,925 136,950 136,975 Unused.	0 1 2 3 ↓ 1 158 1 159 1 160 1 161 to 2 047
State ID	Each restricted, danger or prohibited area has a state ID connected to it, for example ES for Sweden. 2 letter code. Each letter encoded as a 5 bit binary. A B C ↓ Y Z	00001 00010 00011 ↓ 11001 11010

Data field	Definition	Encoded Value
Area leap number	All restricted, danger and prohibited areas have a leap number attached to it, for example Restricted area number 242 in Sweden is written as ES R242. Area leap number in this case would be 242. 1 2 ↓ 8 192	0 1 ↓ 8 191
Supplement to area leap number	A restricted, danger and prohibited area can be divided into several smaller areas denoted with a letter after the leap number. For example ES R242C means sub area C of restricted area 242 in Sweden. Thus, the supplement to the area number would be C in this case. 1 letter encoded as a 5 bit binary. A B C ↓ Y Z	00001 00010 00011 ↓ 11001 11010

5.3.8 FIS-B report request message

Requirement reference	
5.3.8.1	The FIS-B report request message shall use the general request burst format as defined in EN 301 842-2 [5] in table 5.44.
5.3.8.2	The FIS-B report request message shall be encoded as defined in table 5.68.
5.3.8.3	Fields within the FIS-B report request message shall be encoded as defined in table 5.69.
5.3.8.4	The requested message ID (r-mi) shall be set to the FIS-B service indicator "00001111".
5.3.8.5	The FIS-B message identifier (fmi) shall indicate a report request message and be encoded as defined in table 5.54.
5.3.8.6	The message request field (mrq) shall be used to request that a particular FIS-B message is transmitted by the addressed station and be encoded as defined in table 5.54.
5.3.8.7	A FIS-B report request message shall have appended one of the following VDL Mode 4 reservation types: <ul style="list-style-type: none"> • a null reservation; • a response burst with a specific ground station address, or broadcast using address type field = 7; • a unicast reservation with a specific ground station address, or broadcast using address type field = 7; • a periodic broadcast; • an incremental broadcast; • a combined periodic and incremental broadcast; • a BND reservation.
5.3.8.8	A ground station providing coverage of the TV in which a mobile is located, which receives a broadcast report request message from the mobile that does not reserve a specific slot or group of consecutive slots for the response, shall broadcast the requested information once per minute for 3 minutes.
5.3.8.9	A ground station providing coverage of the TV in which a mobile is located, which receives a broadcast report request message from the mobile that reserves a specific slot or group of consecutive slots for the response, shall broadcast the requested information in the slot or group of consecutive slots provided, provided that the ground station has previously established with all other ground stations within range a procedure to avoid multiple broadcasts by ground stations in the same slot.

Requirement reference	
5.3.8.10	A ground station providing coverage of the TV in which a mobile is located, which receives a report request message from the mobile, addressed to the ground station, that does not reserve a specific slot or group of consecutive slots, shall broadcast the requested information once per minute for 3 minutes.
5.3.8.11	A ground station providing coverage of the TV in which a mobile is located, which receives a report request message from the mobile, addressed to the ground station, that reserves a specific slot or group of consecutive slots for the response, shall broadcast the requested information in the slot or group of consecutive slots provided.

Table 5.68: FIS-B report request message bit encoding

Description	Octet	Bit number							
		8	7	6	5	4	3	2	1
mi = general request burst r-mi = FIS-B service indicator	5	0	1	1	1	1	0	0	1
FIS-B message ID (fmi) message requested (mrq)	6	mrq ₁	fmi ₄	fmi ₃	fmi ₂	fmi ₁	0	0	0
local ID (locl)	7	locl ₅	locl ₄	locl ₃	locl ₂	locl ₁	mrq ₄	mrq ₃	mrq ₂
	8	locl ₁₃	locl ₁₂	locl ₁₁	locl ₁₀	locl ₉	locl ₈	locl ₇	locl ₆
reserved (res)	9	res	locl ₂₀	locl ₁₉	locl ₁₈	locl ₁₇	locl ₁₆	locl ₁₅	locl ₁₄

Table 5.69: FIS-B report request message field encoding

Data field	Definition	Encoded value
FIS-B Message ID	See table 5.54	5
message requested (mrq)	See table 5.54	
Local ID	See definition in table 5.56	

5.3.9 Ground system functions

Requirement reference	
5.3.9.1	The ground station shall transmit FIS-B messages.
5.3.9.2	The ground station shall manage the use of VDL Mode 4 slots.
5.3.9.3	The ground station shall accept FIS-B data from the FIS-B server.
5.3.9.4	The ground station shall accept control instructions from the FIS-B server related to the slots in which the ground station may send FIS-B messages.
5.3.9.5	The ground station shall be able to receive VDL Mode 4 FIS-B report request transmissions.
5.3.9.6	The ground station shall pass requests for additional information to the FIS-B server.
5.3.9.7	The ground station shall forward FIS-B requests to the FIS-B server.
5.3.9.8	The ground station shall keep a queue of targets to be transmitted.
5.3.9.9	The ground station shall ensure that data relating to targets that is too old is deleted from the queue.
5.3.9.10	The ground station shall ensure that if a newer report enters the queue for an existing target then it will replace any existing report for that target in the queue.

5.4 Requirements for GNSS Augmentation Service Broadcast (GNS-B) message

5.4.1 Message format

Requirement reference	
5.4.1.1	A GNS-B message shall be sent in a DLS UDATA DLPDU burst of type UINFO as described clause 5.3 of EN 301 842-2 [5].
5.4.1.2	To indicate a GNS-B service, the UDATA ID (udid) field shall be set to "00011" to indicate that a GNS-B service is applied (see clause 5.3.1.3 of EN 301 842-2 [5]).
5.4.1.3	The GNS-B data shall be placed in the information field of the VDL Mode 4 burst.
5.4.1.4	The information field of each GNS-B burst shall start with a GNS-B message identifier, as defined in table 5.70.
5.4.1.5	Each GNS-B message shall use either: <ul style="list-style-type: none"> • a reservation ID (rid) equal to 1, with the burst appended by a null reservation field as defined in clause 5.2.9 of EN 301 842-2 [5]; • or a reservation ID (rid) equal to 0 and an extended reservation ID (erid) equal to 00000binary, with the burst appended by a response reservation field as defined in clause 5.2.18 of EN 301 842-2 [5], with address type field equal to 7; • a reservation ID (rid) equal to 1, with the burst appended by a periodic broadcast reservation field as defined in clause 5.2.10 of EN 301 842-2 [5]; • a reservation ID (rid) equal to 0, with the burst appended by an incremental broadcast reservation field as defined in clause 5.2.11 of EN 301 842-2 [5]; • a reservation ID (rid) equal to 1, with the burst appended by a combined periodic broadcast and incremental broadcast reservation field as defined in clause 5.2.12 of EN 301 842-2 [5]; • or a reservation ID (rid) equal to 0, with the burst appended by a unicast reservation field with sdf=1 as defined in clause 5.2.14 of EN 301 842-2 [5]; • or a reservation ID (rid) equal to 0, with the burst appended by a second frame reservation field as defined in clause 5.2.17 of EN 301 842-2 [5]; • or a reservation ID (rid) equal to 0, with the burst appended by a superframe reservation field as defined in clause 5.2.17 of EN 301 842-2 [5].

Table 5.70: GNS-B message identifier (gmi)

Message	GNS-B Message ID Encoded value
Type 1 Message (Pseudorange corrections)	1
Type 2 Message (GNS-B related data)	2
Type 4 Message (Final Approach Segment Data)	4

5.4.2 Message Type 1

Requirement reference	
5.4.2.1	The GNS-B message type 1 shall be encoded as defined in table 5.71.
5.4.2.2	Fields in the message type 1 shall be encoded as defined in table 5.72.
5.4.2.3	Data for up to 12 satellites shall be transmitted using Message Type 1.
5.4.2.4	The GPS Ephemeris decorrelation parameter and Ephemeris CRC may both be set to zero in Message Type 1 if the GPS receivers do not provide GPS Ephemeris, in which case they shall be ignored.
5.4.2.5	The GNS-B message CRC shall be calculated in accordance with the algorithm in clause 5.4.5.1.
5.4.2.6	All of B1, B2, B3 and B4 may be set to Bin10000000 in one or more measurement blocks, in which case they shall be ignored for that measurement block.

Table 5.71: GNS-B Message Type 1 bit encoding

Description	Octet	Bit number							
		8	7	6	5	4	3	2	1
	5	0	0	0	1	1	1	1	1
message block identifier (mbi)	6	mbi ₈	mbi ₇	mbi ₆	mbi ₅	mbi ₄	mbi ₃	mbi ₂	mbi ₁
GNS-B ID (gid)	7	gid ₈	gid ₇	gid ₆	gid ₅	gid ₄	gid ₃	gid ₂	gid ₁
	8	gid ₁₆	gid ₁₅	gid ₁₄	gid ₁₃	gid ₁₂	gid ₁₁	gid ₁₀	gid ₉
	9	gid ₂₄	gid ₂₃	gid ₂₂	gid ₂₁	gid ₂₀	gid ₁₉	gid ₁₈	gid ₁₇
message identifier (gmi)	10	0	0	0	0	0	gmi ₃	gmi ₂	gmi ₁
message length (len)	11	len ₈	len ₇	len ₆	len ₅	len ₄	len ₃	len ₂	len ₁
modified Z-count (zc)	12	zc ₈	zc ₇	zc ₆	zc ₅	zc ₄	zc ₃	zc ₂	zc ₁
additional message flag (amf)	13	amf ₂	amf ₁	zc ₁₄	zc ₁₃	zc ₁₂	zc ₁₁	zc ₁₀	zc ₉
number of measurements (n) measurement type (t)	14	t ₃	t ₂	t ₁	n ₅	n ₄	n ₃	n ₂	n ₁
ephemeris decorrelation parameter (edp)	15	edp ₈	edp ₇	edp ₆	edp ₅	edp ₄	edp ₃	edp ₂	edp ₁
ephemeris CRC(ec)	16	ec ₈	ec ₇	ec ₆	ec ₅	ec ₄	ec ₃	ec ₂	ec ₁
	17	ec ₁₆	ec ₁₅	ec ₁₄	ec ₁₃	ec ₁₂	ec ₁₁	ec ₁₀	ec ₉
source availability duration (ad)	18	ad ₈	ad ₇	ad ₆	ad ₅	ad ₄	ad ₃	ad ₂	ad ₁
For N measurement blocks (i=1 to i=N): ranging source ID (id)	19+(i-1)x11	id ₈	id ₇	id ₆	id ₅	id ₄	id ₃	id ₂	id ₁
issue of data (iod)	20+(i-1)x11	iod ₈	iod ₇	iod ₆	iod ₅	iod ₄	iod ₃	iod ₂	iod ₁
pseudo range correction (prc)	21+(i-1)x11	prc ₈	prc ₇	prc ₆	prc ₅	prc ₄	prc ₃	prc ₂	prc ₁
	22+(i-1)x11	prc ₁₆	prc ₁₅	prc ₁₄	prc ₁₃	prc ₁₂	prc ₁₁	prc ₁₀	prc ₉
range rate correction (rrc)	23+(i-1)x11	rrc ₈	rrc ₇	rrc ₆	rrc ₅	rrc ₄	rrc ₃	rrc ₂	rrc ₁
	24+(i-1)x11	rrc ₁₆	rrc ₁₅	rrc ₁₄	rrc ₁₃	rrc ₁₂	rrc ₁₁	rrc ₁₀	rrc ₉
σ_{pr_gnd} (sd)	25+(i-1)x11	sd ₈	sd ₇	sd ₆	sd ₅	sd ₄	sd ₃	sd ₂	sd ₁
integrity parameter B1 (b1)	26+(i-1)x11	b1 ₈	b1 ₇	b1 ₆	b1 ₅	b1 ₄	b1 ₃	b1 ₂	b1 ₁
integrity parameter B2 (b2)	27+(i-1)x11	b2 ₈	b2 ₇	b2 ₆	b2 ₅	b2 ₄	b2 ₃	b2 ₂	b2 ₁
integrity parameter B3 (b3)	28+(i-1)x11	b3 ₈	b3 ₇	b3 ₆	b3 ₅	b3 ₄	b3 ₃	b3 ₂	b3 ₁
integrity parameter B4 (b4)	29+(i-1)x11	b4 ₈	b4 ₇	b4 ₆	b4 ₅	b4 ₄	b4 ₃	b4 ₂	b4 ₁
GNS-B message CRC (gc)	30+(N-1)x11	gc ₈	gc ₇	gc ₆	gc ₅	gc ₄	gc ₃	gc ₂	gc ₁
	31+(N-1)x11	gc ₁₆	gc ₁₅	gc ₁₄	gc ₁₃	gc ₁₂	gc ₁₁	gc ₁₀	gc ₉
	32+(N-1)x11	gc ₂₄	gc ₂₃	gc ₂₂	gc ₂₁	gc ₂₀	gc ₁₉	gc ₁₈	gc ₁₇
	33+(N-1)x11	gc ₃₂	gc ₃₁	gc ₃₀	gc ₂₉	gc ₂₈	gc ₂₇	gc ₂₆	gc ₂₅

Table 5.72: GNS-B Message Type 1 field encoding

Data field	Definition	Encoded Value	Decoded value (if different)
Message Identifier (gmi)	See table 5.70.	1	
GNS-B message block identifier (mbi)	This represents the operating mode of the GNS-B message block. Normal GNS-B message. Test GNS-B message.	10101010 11111111	
GNS-B ID (gid)	4-character GNS-B identification included to differentiate between broadcasting stations. Each character is coded using the lower 6 bits of its International Alphabet No. 5 (IA-5) representation. Only upper case letters, numeric digits and IA-5 "blank" are used. The right-most character is transmitted first. For a 3-character GNS-B ID, the right most (first transmitted) character shall be IA-5 "blank". Note: The GNS-B ID is normally identical to the location indicator at the nearest airport. Assignment of GNS-B IDs will be co-ordinated as appropriate to avoid conflicts.		
Message length (len)	length of the message in 8-bit bytes including the 6-byte message block header (i.e. GNS-B Message block identifier, GNS-B ID, Message Type Identifier, Message Length), the message and the 4-byte message CRC code. Unused. 10 bytes 11 bytes 255 bytes	0 to 9 10 11 255	
Modified Z-count (zc)	The modified Z-count defines the reference time for all the message parameters in this message (including pseudorange correction and range-rate correction). The modified Z-count resets on the hour (xx:00), 20 minutes past the hour (xx:20) and 40 minutes past the hour (xx:40) referenced to GPS time. 00 minutes 00,0 s 00 minutes 00,1 s 00 minutes 00,2 s 01 minute 00,0 s 01 minute 00,1 s 19 minutes 59,9 s 20 minutes 00,0 s	0 1 2 600 601 11 999 12 000	
Additional message flag (amf)	Identifies whether measurement blocks are contained in one or two Type 1 messages in a single frame. All measurement blocks are contained in one Type 1 Message. This is the first of two Type 1 Messages in a frame containing measurement blocks. Unused. This is the second of two Type 1 Messages in a frame containing measurement blocks.	0 1 2 3	
Number of measurements (n)	This parameter identifies the number of measurement blocks in the message. 0 blocks. 1 block. 12 blocks.	0 1 12	

Data field	Definition	Encoded Value	Decoded value (if different)
Measurement type (t)	This parameter identifies the type of ranging signal from which the corrections have been computed. C/A or CSA code L1. Reserved. Reserved. Reserved. Unused.	0 1 2 3 4 to 7	
Ephemeris decorrelation parameter (edp)	This parameter characterizes the impact of residual ephemeris errors due to decorrelation for the first measurement block in the message. SBAS Geostationary Satellite. 0 m/m 5×10^{-6} m/m 10×10^{-6} m/m $1,275 \times 10^{-3}$ m/m	0 0 1 2 255	
Ephemeris CRC (ec):	This parameter characterizes the impact of residual ephemeris errors due to decorrelation for the first measurement block in the message.	See clause 5.4.5.3	
Source availability duration (ad)	The predicted duration for which corrections for the ranging source are expected to remain available, relative to the modified Z-count for the first measurement block. 0 s 10 s 20 s 2 530 s $2\ 540\ \text{s} \leq \text{duration}$ Prediction of source availability duration not provided.	0 1 2 253 254 255	
For N measurement blocks (ranging from i=1 to i=N): Nmax = 12			
Ranging source ID (id)	This parameter defines the identity of the ranging source to which subsequent message block data are applicable. GPS satellite IDs (PRN). Reserved. GLONASS satellite IDs. Unused. SBAS satellite IDs (PRN). Unused.	1 - 36 37 38 - 61 62 - 119 120 - 138 139 - 255	
Issue of data (iod)	The issue of data associated with the ephemeris data used to determine pseudorange and range rate corrections. For GPS, IOD encode GPS IODE parameter. For GLONASS, IOD encode GLONASS t_b parameter. For SBAS, IOD.	255	
Pseudorange correction (prc)	The correction to the ranging source pseudorange transmitted to the airborne subsystem. -327,67 m -327,66 m -327,65 m 0 m 0,01 m +327,66 m +327,67 m Unused	0 1 2 32 767 32 768 65 533 65 534 65 535	

Data field	Definition	Encoded Value	Decoded value (if different)
Range rate correction (rrc)	The rate of change of the pseudorange correction. -32,767 m -32,766 m -32,765 m 0 m 0,001 m +32,766 m +32,767 m Unused	0 1 2 32 767 32 768 65 533 65 534 65 535	
σ_{pr_gnd} (sd)	The standard deviation of a normal distribution associated with the signal in space contribution of the pseudorange error. 0 m 0,02 m 0,04 m 5,06 m 5,08 m Ranging source correction invalid.	0 1 2 253 254 255	
B1 (b1), B2 (b2), B3 (b3), B4 (b4)	The integrity parameters associated with the pseudorange corrections provided in the same measurement block (see ICAO Annex 10 [7] and GBAS MOPS [8], clause A.2.1). Bit 8: Positive. Negative. Bits 1 to 7: 0 m 0,05 m 6,34 m 6,35 m Reference receiver was not used to compute the pseudorange correction.	0 1 0 1 126 127 10 000 000	
GNS-B Message CRC (gc)	See clause 5.4.5.1.		

5.4.3 Message Type 2

Requirement reference	
5.4.3.1	The GNS-B message type 2 shall be encoded as defined in table 5.73.
5.4.3.2	Fields in the message type 2 shall be encoded as defined in table 5.74.

Table 5.73: GNS-B message type 2 bit encoding

Description	Octet	Bit number							
		8	7	6	5	4	3	2	1
	5	0	0	0	1	1	1	1	1
message block identifier (mbi)	6	mbi ₈	mbi ₇	mbi ₆	mbi ₅	mbi ₄	mbi ₃	mbi ₂	mbi ₁
GNS-B ID (gid)	7	gid ₈	gid ₇	gid ₆	gid ₅	gid ₄	gid ₃	gid ₂	gid ₁
	8	gid ₁₆	gid ₁₅	gid ₁₄	gid ₁₃	gid ₁₂	gid ₁₁	gid ₁₀	gid ₉
	9	gid ₂₄	gid ₂₃	gid ₂₂	gid ₂₁	gid ₂₀	gid ₁₉	gid ₁₈	gid ₁₇
message identifier (gmi)	10	0	0	0	0	0	gmi ₃	gmi ₂	gmi ₁
message length (len)	11	len ₈	len ₇	len ₆	len ₅	len ₄	len ₃	len ₂	len ₁
GNS-B reference receivers (r)	12	cid ₃	cid ₂	cid ₁	res	ac ₂	ac ₁	r ₂	r ₁
GNS-B accuracy designator letter (ac)									
GNS-B continuity/integrity designator (cid)									
local magnetic variation (v)	13	v ₈	v ₇	v ₆	v ₅	v ₄	v ₃	v ₂	v ₁
res	14	res	res	res	res	res	v ₁₁	v ₁₀	v ₉
σ vert iono grad (vi)	15	vi ₈	vi ₇	vi ₆	vi ₅	vi ₄	vi ₃	vi ₂	vi ₁
refractivity index (i)	16	i ₈	i ₇	i ₆	i ₅	i ₄	i ₃	i ₂	i ₁
scale height (h)	17	h ₈	h ₇	h ₆	h ₅	h ₄	h ₃	h ₂	h ₁
refractivity uncertainty (u)	18	u ₈	u ₇	u ₆	u ₅	u ₄	u ₃	u ₂	u ₁
latitude (lat)	19	lat ₈	lat ₇	lat ₆	lat ₅	lat ₄	lat ₃	lat ₂	lat ₁
	20	lat ₁₆	lat ₁₅	lat ₁₄	lat ₁₃	lat ₁₂	lat ₁₁	lat ₁₀	lat ₉
	21	lat ₂₄	lat ₂₃	lat ₂₂	lat ₂₁	lat ₂₀	lat ₁₉	lat ₁₈	lat ₁₇
	22	lat ₃₂	lat ₃₁	lat ₃₀	lat ₂₉	lat ₂₈	lat ₂₇	lat ₂₆	lat ₂₅
longitude (lon)	23	lon ₈	lon ₇	lon ₆	lon ₅	lon ₄	lon ₃	lon ₂	lon ₁
	24	lon ₁₆	lon ₁₅	lon ₁₄	lon ₁₃	lon ₁₂	lon ₁₁	lon ₁₀	lon ₉
	25	lon ₂₄	lon ₂₃	lon ₂₂	lon ₂₁	lon ₂₀	lon ₁₉	lon ₁₈	lon ₁₇
	26	lon ₃₂	lon ₃₁	lon ₃₀	lon ₂₉	lon ₂₈	lon ₂₇	lon ₂₆	lon ₂₅
ellipsoid height (h)	27	h ₈	h ₇	h ₆	h ₅	h ₄	h ₃	h ₂	h ₁
	28	h ₁₆	h ₁₅	h ₁₄	h ₁₃	h ₁₂	h ₁₁	h ₁₀	h ₉
	29	h ₂₄	h ₂₃	h ₂₂	h ₂₁	h ₂₀	h ₁₉	h ₁₈	h ₁₇
GNS-B Message CRC (gc)	30	gc ₈	gc ₇	gc ₆	gc ₅	gc ₄	gc ₃	gc ₂	gc ₁
	31	gc ₁₆	gc ₁₅	gc ₁₄	gc ₁₃	gc ₁₂	gc ₁₁	gc ₁₀	gc ₉
	32	gc ₂₄	gc ₂₃	gc ₂₂	gc ₂₁	gc ₂₀	gc ₁₉	gc ₁₈	gc ₁₇
	33	gc ₃₂	gc ₃₁	gc ₃₀	gc ₂₉	gc ₂₈	gc ₂₇	gc ₂₆	gc ₂₅

Table 5.74: GNS-B message type 2 field encoding

Data field	Definition	Encoded Value	Decoded value (if different)
Message Identifier (gmi)	See table 5.70.	2	
GNS-B message block identifier (mbi)	As defined in GNS-B message type 1 encoding.		
GNS-B ID (gid)	As defined in GNS-B message type 1 encoding.		
Message length (len)	As defined in GNS-B message type 1 encoding.		
GNS-B reference receivers (r)	This defines the number of GNSS reference receivers installed: GNS-B installed with 2 reference receivers. GNS-B installed with 3 reference receivers. GNS-B installed with 4 reference receivers. Reserved.	0 1 2 3	
GNS-B accuracy designator letter (ac)	This parameter defines the letter designator indicating the minimum signal-in-space accuracy performance provided by GNS-B: GNS-B has accuracy designation A. GNS-B has accuracy designation B. GNS-B has accuracy designation C. Reserved.	0 1 2 3	
GNS-B continuity/integrity designator (cid)	The GNS-B Continuity / Integrity Designator (GCID) is a numerical designator which defines the operational performance of the GNS-B: Reserved. GCID 1 GCID 2 GCID 3 GCID 4 Reserved. Reserved. GNS-B unhealthy.	0 1 2 3 4 5 6 7	
Local magnetic variation (v)	This data parameter defines the published magnetic variation at the GNS-B reference point: Bit 1: Positive, denotes eastward variation (clockwise from due north). Negative, denotes west variation (counter-clockwise from true north). Bits 2 to 11: 0 degree 0,25 degrees 0,50 degrees 180 degrees Unused.	0 1 0 1 2 720 721 to 1 023	
σ vert iono grad (vi)	This data parameter represents the standard deviation of a normal distribution associated with the residual ionospheric uncertainty due to spatial decorrelation. 0 $0,1 \times 10^{-6}$ m/m $0,2 \times 10^{-6}$ m/m $25,5 \times 10^{-6}$ m/m	0 1 2 255	

Data field	Definition	Encoded Value	Decoded value (if different)
Refractivity index (i)	This defines the refractivity index parameter value stored in the GNS-B Ground Subsystem. Bit 8: Positive. Negative. Bits 1 to 7: 0 3 378 381	0 1 0 1 126 127	
Scale height (h)	This defines the scale height parameter value stored in the GNS-B Ground Subsystem. 0 100 200 25 400 25 500	0 1 2 254 255	
Refractivity uncertainty (u)	This defines the refractivity uncertainty parameter value stored in the GNS-B Ground Subsystem. 0 1 2 255	0 1 2 255	
Latitude (lat)	This defines the GNS-B Reference Point latitude parameter value as stored in GNS-B Ground Subsystem. Bit 32: Positive (North). Negative (South). Bits 1 to 31: 0 degree 0 minute 0 arc s. 0 degree 0 minute 0,0005 arc s. 0 degree 0 minute 0,00010 arc s. 89 degrees 59 minutes 59,9995 arc s. 90 degrees 0 minute 0 arc s. Unused.	0 1 0 1 2 647 999 999 648 000 000 648 000 001 to 2 147 483 647	
Longitude (lon)	This defines the GNS-B Reference Point longitude parameter value as stored in the GNS-B Ground Subsystem. Bit 32: Positive (East). Negative (West). Bits 1 to 31: 0 degree 0 minute 0 arc s. 0 degree 0 minute 0,0005 arc s. 0 degree 0 minute 0,00010 arc s. 89 degrees 59 minutes 59,9995 arc s. 90 degrees 0 minute 0 arc s. 180 degrees 0 minute 0 arc s. Unused.	0 1 0 1 2 647 999 999 648 000 000 1 296 000 000 1 296 000 001 to 2 147 483 647	

Data field	Definition	Encoded Value	Decoded value (if different)
Ellipsoid height (h)	This defines the GNS-B reference point height above the WGS-84 ellipsoid parameter as stored in the GNS-B ground subsystem. Bit 24: Positive. Negative. Bits 1 - 23: 0 m 0,01 m 83 886,07 m	0 1 0 1 8 388 607	
GNS-B Message CRC (gc)	See clause 5.4.5.1.		

5.4.4 Message Type 4

Requirement reference	
5.4.4.1	The GNS-B message type 4 shall be encoded as defined in table 5.75.
5.4.4.2	Fields in the message type 4 shall be encoded as defined in table 5.76.
5.4.4.3	Message Type 4 shall contain up to eight Final Approach Segment Data (FAS) blocks.
5.4.4.3a	Each FAS data block shall be encoded according to ICAO Annex 10 [7] and A.2.4 in GBAS MOPS [8] if not specified otherwise here.
5.4.4.4	All the FAS blocks, stored in the ground station shall be transmitted in sequence.
5.4.4.5	The GNS-B reference point shall be defined as the WGS-84 co-ordinates of a single RR antenna location for each installation.

Table 5.75: GNS-B message type 4 bit encoding

Description	Octet	Bit number							
		8	7	6	5	4	3	2	1
	5	0	0	0	1	1	1	1	1
message block identifier (mbi)	6	mbi ₈	mbi ₇	mbi ₆	mbi ₅	mbi ₄	mbi ₃	mbi ₂	mbi ₁
GNS-B ID (gid)	7	gid ₈	gid ₇	gid ₆	gid ₅	gid ₄	gid ₃	gid ₂	gid ₁
	8	gid ₁₆	gid ₁₅	gid ₁₄	gid ₁₃	gid ₁₂	gid ₁₁	gid ₁₀	gid ₉
	9	gid ₂₄	gid ₂₃	gid ₂₂	gid ₂₁	gid ₂₀	gid ₁₉	gid ₁₈	gid ₁₇
message identifier (gmi)	10	0	0	0	0	0	gmi ₃	gmi ₂	gmi ₁
message length (len)	11	len ₈	len ₇	len ₆	len ₅	len ₄	len ₃	len ₂	len ₁
data set length (l)	12	l ₈	l ₇	l ₆	l ₅	l ₄	l ₃	l ₂	l ₁
For N FAS data blocks (i=1 to i=N): operation type (ot) SBAS provider ID (sp)	13+(i-1)x40	sp ₄	sp ₃	sp ₂	sp ₁	ot ₄	ot ₃	ot ₂	ot ₁
airport ID (ai)	14+(i-1)x40	ai ₈	ai ₇	ai ₆	ai ₅	ai ₄	ai ₃	ai ₂	ai ₁
	15+(i-1)x40	ai ₁₆	ai ₁₅	ai ₁₄	ai ₁₃	ai ₁₂	ai ₁₁	ai ₁₀	ai ₉
	16+(i-1)x40	ai ₂₄	ai ₂₃	ai ₂₂	ai ₂₁	ai ₂₀	ai ₁₉	ai ₁₈	ai ₁₇
	17+(i-1)x40	ai ₃₂	ai ₃₁	ai ₃₀	ai ₂₉	ai ₂₈	ai ₂₇	ai ₂₆	ai ₂₅
runway number (rn) runway letter (rl)	18+(i-1)x40	rl ₂	rl ₁	rn ₆	rn ₅	rn ₄	rn ₃	rn ₂	rn ₁
approach performance designator (apd) route indicator (ri)	19+(i-1)x40	ri ₅	ri ₄	ri ₃	ri ₂	ri ₁	apd ₃	apd ₂	apd ₁
reference path data selector (rps)	20+(i-1)x40	rps ₈	rps ₇	rps ₆	rps ₅	rps ₄	rps ₃	rps ₂	rps ₁
reference path ID (rpi)	21+(i-1)x40	rpi ₈	rpi ₇	rpi ₆	rpi ₅	rpi ₄	rpi ₃	rpi ₂	rpi ₁
	22+(i-1)x40	rpi ₁₆	rpi ₁₅	rpi ₁₄	rpi ₁₃	rpi ₁₂	rpi ₁₁	rpi ₁₀	rpi ₉
	23+(i-1)x40	rpi ₂₄	rpi ₂₃	rpi ₂₂	rpi ₂₁	rpi ₂₀	rpi ₁₉	rpi ₁₈	rpi ₁₇
	24+(i-1)x40	rpi ₃₂	rpi ₃₁	rpi ₃₀	rpi ₂₉	rpi ₂₈	rpi ₂₇	rpi ₂₆	rpi ₂₅

Description	Octet	Bit number							
		8	7	6	5	4	3	2	1
LTP/FTP latitude (ltla)	25+(i-1)x40	ltla ₈	ltla ₇	ltla ₆	ltla ₅	ltla ₄	ltla ₃	ltla ₂	ltla ₁
	26+(i-1)x40	ltla ₁₆	ltla ₁₅	ltla ₁₄	ltla ₁₃	ltla ₁₂	ltla ₁₁	ltla ₁₀	ltla ₉
	27+(i-1)x40	ltla ₂₄	ltla ₂₃	ltla ₂₂	ltla ₂₁	ltla ₂₀	ltla ₁₉	ltla ₁₈	ltla ₁₇
	28+(i-1)x40	ltla ₃₂	ltla ₃₁	ltla ₃₀	ltla ₂₉	ltla ₂₈	ltla ₂₇	ltla ₂₆	ltla ₂₅
LTP/FTP longitude (ltlo)	29+(i-1)x40	ltlo ₈	ltlo ₇	ltlo ₆	ltlo ₅	ltlo ₄	ltlo ₃	ltlo ₂	ltlo ₁
	30+(i-1)x40	ltlo ₁₆	ltlo ₁₅	ltlo ₁₄	ltlo ₁₃	ltlo ₁₂	ltlo ₁₁	ltlo ₁₀	ltlo ₉
	31+(i-1)x40	ltlo ₂₄	ltlo ₂₃	ltlo ₂₂	ltlo ₂₁	ltlo ₂₀	ltlo ₁₉	ltlo ₁₈	ltlo ₁₇
	32+(i-1)x40	ltlo ₃₂	ltlo ₃₁	ltlo ₃₀	ltlo ₂₉	ltlo ₂₈	ltlo ₂₇	ltlo ₂₆	ltlo ₂₅
LTP/FTP height (lth)	33+(i-1)x40	lth ₈	lth ₇	lth ₆	lth ₅	lth ₄	lth ₃	lth ₂	lth ₁
	34+(i-1)x40	lth ₁₆	lth ₁₅	lth ₁₄	lth ₁₃	lth ₁₂	lth ₁₁	lth ₁₀	lth ₉
DFPAP latitude (fpla)	35+(i-1)x40	fpla ₈	fpla ₇	fpla ₆	fpla ₅	fpla ₄	fpla ₃	fpla ₂	fpla ₁
	36+(i-1)x40	fpla ₁₆	fpla ₁₅	fpla ₁₄	fpla ₁₃	fpla ₁₂	fpla ₁₁	fpla ₁₀	fpla ₉
	37+(i-1)x40	fpla ₂₄	fpla ₂₃	fpla ₂₂	fpla ₂₁	fpla ₂₀	fpla ₁₉	fpla ₁₈	fpla ₁₇
DFPAP longitude (fplo)	38+(i-1)x40	fplo ₈	fplo ₇	fplo ₆	fplo ₅	fplo ₄	fplo ₃	fplo ₂	fplo ₁
	39+(i-1)x40	fplo ₁₆	fplo ₁₅	fplo ₁₄	fplo ₁₃	fplo ₁₂	fplo ₁₁	fplo ₁₀	fplo ₉
	40+(i-1)x40	fplo ₂₄	fplo ₂₃	fplo ₂₂	fplo ₂₁	fplo ₂₀	fplo ₁₉	fplo ₁₈	fplo ₁₇
approach threshold crossing height (apth)	41+(i-1)x40	apth ₈	apth ₇	apth ₆	apth ₅	apth ₄	apth ₃	apth ₂	apth ₁
approach TCH units selector (aptu)	42+(i-1)x40	aptu ₁	apth ₁₅	apth ₁₄	apth ₁₃	apth ₁₂	apth ₁₁	apth ₁₀	apth ₉
glide path angle (gpa)	43+(i-1)x40	gpa ₈	gpa ₇	gpa ₆	gpa ₅	gpa ₄	gpa ₃	gpa ₂	gpa ₁
	44+(i-1)x40	gpa ₁₆	gpa ₁₅	gpa ₁₄	gpa ₁₃	gpa ₁₂	gpa ₁₁	gpa ₁₀	gpa ₉
course width (cw)	45+(i-1)x40	cw ₈	cw ₇	cw ₆	cw ₅	cw ₄	cw ₃	cw ₂	cw ₁
DLength offset (dlo)	46+(i-1)x40	dlo ₈	dlo ₇	dlo ₆	dlo ₅	dlo ₄	dlo ₃	dlo ₂	dlo ₁
FAS CRC (fc)	47+(i-1)x40	fc ₈	fc ₇	fc ₆	fc ₅	fc ₄	fc ₃	fc ₂	fc ₁
	48+(i-1)x40	fc ₁₆	fc ₁₅	fc ₁₄	fc ₁₃	fc ₁₂	fc ₁₁	fc ₁₀	fc ₉
	49+(i-1)x40	fc ₂₄	fc ₂₃	fc ₂₂	fc ₂₁	fc ₂₀	fc ₁₉	fc ₁₈	fc ₁₇
	50+(i-1)x40	fc ₃₂	fc ₃₁	fc ₃₀	fc ₂₉	fc ₂₈	fc ₂₇	fc ₂₆	fc ₂₅
FAS vertical alert limit /approach status (va)	51+(i-1)x40	va ₈	va ₇	va ₆	va ₅	va ₄	va ₃	va ₂	va ₁
FAS lateral alert limit/approach status (la)	52+(i-1)x40	la ₈	la ₇	la ₆	la ₅	la ₄	la ₃	la ₂	la ₁
GNS-B message CRC (gc)	53+(i-1)x40	gc ₈	gc ₇	gc ₆	gc ₅	gc ₄	gc ₃	gc ₂	gc ₁
	54+(i-1)x40	gc ₁₆	gc ₁₅	gc ₁₄	gc ₁₃	gc ₁₂	gc ₁₁	gc ₁₀	gc ₉
	55+(i-1)x40	gc ₂₄	gc ₂₃	gc ₂₂	gc ₂₁	gc ₂₀	gc ₁₉	gc ₁₈	gc ₁₇
	56+(i-1)x40	gc ₃₂	gc ₃₁	gc ₃₀	gc ₂₉	gc ₂₈	gc ₂₇	gc ₂₆	gc ₂₅

Table 5.76: GNS-B message type 4 field encoding

Data field	Definition	Encoded Value	Decoded value (if different)
Message Identifier (gmi)	See table 5.70.	4	
GNS-B message block identifier (mbi)	As defined in GNS-B message type 1 encoding.		
GNS-B ID (gid)	As defined in GNS-B message type 1 encoding.		
Message length (len)	As defined in GNS-B message type 1 encoding.		
Data set length (l)	This field denotes the Type 4 Message data set length, which indicates the number of bytes in the data set. Unused. 2 3 212 Unused.	0 to 1 2 3 212 212 to 255	
FAS data block (f)	See encoding for data fields below.		
Operation type (ot)	This defines the operation type parameter value as stored in the GNS-B Ground Subsystem and shall be set to the code applicable to "straight in approach". Straight in approach procedure. Reserved.	0 1 to 15	
SBAS provider ID (sp)	This defines the SBAS service provider ID parameter value as stored in the GNS-B Ground Subsystem. Note: this parameter is not used for approaches conducted using the GNS-B Ground Subsystem corrections. WAAS EGNOS MSAS Reserved FAS data block is to be used with GBAS only. FAS data block can be used with any SBAS service provider.	0 1 2 3 to 13 14 15	
Airport ID (ai)	This defines the airport identification parameter value as stored in the GNS-B Ground Subsystem. Each character is coded using the lower 6 bits of its IA-5 representation. For each character b_i is transmitted first, and 2 zero bits are appended after b_6 , so that 8 bits are transmitted for each character. Only upper case letters, numeric digits and IA-5 "space" are used. The rightmost character is transmitted first. For a three-character GBAS ID, the rightmost (first transmitted) character shall be IA-5 "space".		
Runway number (rn)	This defines the runway number parameter value as stored in the GNS-B Ground Subsystem. Heliport. Runway number.	0 1 to 36	
Runway letter (rl)	This defines the runway letter parameter value as stored in the GNS-B Ground Subsystem. No letter R (right) C (centre) L (left)	0 1 2 3	

Data field	Definition	Encoded Value	Decoded value (if different)
Approach performance designator (apd)	This defines the code applicable to Category 1 approach. Reserved. Category I. Reserved for Category II. Reserved for Category III. Reserved.	0 1 2 3 4 to 7	
Route indicator (ri)	This defines the route indicator parameter value as stored in the GNS-B Ground Subsystem. The letter is coded using bits b_1 through b_5 of its IA-5 representation. Bit b_1 is transmitted first. Only upper case letters, excluding "I" and "O", or IA-5 "space" are used.		
Reference path data selector (rps)	This defines the reference path data selector parameter value as stored in the GNS-B Ground Subsystem. 0 1 48 Unused.	0 1 48 49 to 255	
Reference path ID (rpi)	This defines the reference path identifier parameter value as stored in the GNS-B Ground Subsystem. Each character is coded using bits b_1 through b_6 of its IA-5 representation. For each character, b_1 is transmitted first, and 2 zero bits are appended after b_6 so that 8 bits are transmitted for each character. Only upper case letters, numeric digits and IA-5 "space" are used. The rightmost character is transmitted first. For a three-character reference path identifier, the rightmost (first transmitted) character shall be IA-5 "space".		
LTP/FTP latitude (ltla)	This defines the LTP/FTP latitude parameter value as stored in the GNS-B Ground Subsystem and shall represent the latitude (in arc s) of the LTP/FTP point defined in WGS-84 co-ordinates. Bit 32: Positive (North). Negative (South). Bits 1 to 31: 0 degree 0 minute 0 arc s 0 degree 0 minute 0,0005 arc s 0 degree 0 minute 0,00010 arc s 89 degrees 59 minutes 59,9995 arc s 90 degrees 0 minute 0 arc s Unused.	0 1 0 1 2 647 999 999 648 000 000 648 000 001 to 2 147 483 647	

Data field	Definition	Encoded Value	Decoded value (if different)
LTP/FTP longitude (lto)	This defines the LTP/FTP longitude parameter value as stored in the GNS-B Ground Subsystem and shall represent the longitude (in arc s) of the LTP/FTP point defined in WGS-84 co-ordinates. Bit 32: Positive (East). Negative (West). Bits 1 to 31: 0 degree 0 minute 0 arc s 0 degree 0 minute 0,0005 arc s 0 degree 0 minute 0,00010 arc s 89 degrees 59 minutes 59,9995 arc s 90 degrees 0 minute 0 arc s 180 degrees 0 minute 0 arc s Unused.	0 1 0 1 2 647 999 999 648 000 000 1 296 000 000 1 296 000 001 to 2 147 483 647	
LTP/FTP height (lth)	This defines the LTP/FTP height parameter value as stored in the GNS-B Ground Subsystem. -512,0 m -511,9 m 0,0 m 0,1 m 6 041,5 m	0 1 5 120 5 121 65 535	
DFPAP latitude (fpla)	The delta Flight Path Alignment Point (FPAP) Latitude field defines the delta FPAP latitude parameter value as stored in the GNS-B Ground Subsystem. Bit 24 Positive. Negative. Bits 1 - 23 0 degree 0 minute 0 arc s 0 degree 0 minute 0,0005 arc s 1 degree 0 minute 0 arc s Unused.	0 1 0 1 7 200 000 7 200 001 to 8 388 607	
DFPAP longitude (fplo)	The delta Flight Path Alignment Point (FPAP) Longitude field defines the delta FPAP longitude parameter value as stored in the GNS-B Ground Subsystem. Bit 24 Positive. Negative. Bits 1 - 23 0 degree 0 minute 0 arc s 0 degree 0 minute 0,0005 arc s 1 degree 0 minute 0 arc s Unused.	0 1 0 1 7 200 000 7 200 001 to 8 388 607	

Data field	Definition	Encoded Value	Decoded value (if different)
Approach threshold crossing height (aph)	The approach Threshold Crossing Height (TCH) field defines the TCH parameter value as stored in the GNS-B Ground Subsystem. In Metres: 0 m 0,05 m 1 638,35 m Alternatively. In Feet: 0 ft 0,1 ft 3 276,7 ft	0 1 32 767 0 1 32 767	
Approach TCH units selector (aptu)	This defines the TCH Unit Selector parameter value as stored in the GNS-B Ground Subsystem. Feet Metres	0 1	
Glide path angle (gpa)	The Glide Path Angle (GPA) field defines the GPA parameter value as stored in the GNS-B Ground Subsystem and shall represent the glidepath angle of the FAS path with respect to the horizontal plane tangent to the WGS-84 ellipsoid at the LTP/FTP. 0 degree 0,01 degrees 0,02 degrees 89,99 degrees 90 degrees Unused.	0 1 2 8 999 9 000 9 001 to 65 535	
Course width (cw)	This defines the course width parameter value as stored in the GNS-B Ground Subsystem and shall represent the lateral displacement at which full-scale deflection of a course deviation indicator from the path defined by the FAS at the LTP/FTP is attained. 80 m 80,25 m 80,50 m 143,75 m	0 1 2 255	
DLength offset (dlo)	This defines the delta length offset parameter value as stored in the GNS-B Ground Subsystem and shall represent the distance from the stop end of the runway to the FAS Path Alignment Point. 0 m 8 m 16 m 24 m 2 032 m Not provided.	0 1 2 3 254 255	
Final Approach Segment CRC (fc)	This defines the FAS CRC value as stored in the GNS-B Ground Subsystem. The 32 bit cyclic redundancy check is appended to the end of each FAS data block in order to ensure FAS data integrity. The length of the CRC shall be k = 32 bits. For encoding see clause 5.5.5.2.		

Data field	Definition	Encoded Value	Decoded value (if different)
FAS vertical alert limit /approach status (va)	Vertical Alert Limit. 0 m 0,1 m 0,2 m 25,4 m Do not use vertical deviations.	0 1 2 254 255	
FAS lateral alert limit/approach status (la)	Lateral Alert Limit. 0 m 0,2 m 0,4 m 50,8 m Do not use approach	0 1 2 254 255	
GNS-B Message CRC (gc)	See clause 5.4.5.1.		

5.4.5 CRC Calculation

5.4.5.1 GNS-B CRC

Requirement reference	
5.4.5.1.1	The GNS-B CRC generator polynomial shall be: $G(x) = x^{32} + x^{31} + x^{24} + x^{22} + x^{16} + x^{14} + x^8 + x^7 + x^5 + x^3 + x + 1$
5.4.5.1.2	The CRC information field, $M(x)$, shall be: $M(x) = \sum_{i=1}^n m_i x^{n-i} = m_1 x^{n-1} + m_2 x^{n-2} + \dots + m_n x^0$
5.4.5.1.3	$M(x)$ shall be formed from the 48 bit GNS-B message block header and all bits of the variable-length message, excluding the CRC.
5.4.5.1.4	Bits shall be arranged in the order transmitted, such that m_1 corresponds to the first transmitted bit of the message block header, and m_n corresponds to the last transmitted bit of the (n-48) message bits.
5.4.5.1.5	The following variables shall be used to compute the CRC-value. Start Value shall be 0. Reflect on input shall be done. Reflect on output shall be done. XOR on output shall not be done (XOR value shall be 0).

5.4.5.2 FAS CRC

Requirement reference	
5.4.5.2.1	The FAS CRC generator polynomial shall be: $G(x) = x^{32} + x^{31} + x^{24} + x^{22} + x^{16} + x^{14} + x^8 + x^7 + x^5 + x^3 + x + 1$
5.4.5.2.2	The CRC information field, $M(x)$, shall be: $M(x) = \sum_{i=1}^{272} m_i x^{272-i} = m_1 x^{271} + m_2 x^{270} + \dots + m_{272} x^0$
5.4.5.2.3	$M(x)$ shall be formed from all bits of the associated FAS data block, excluding the CRC.
5.4.5.2.4	Bits shall be arranged in the order transmitted, such that m_1 corresponds to the LSB of the operation type field, and m_{272} corresponds to the MSB of the Δ Length Offset.
5.4.5.2.5	The following variables shall be used to compute the CRC-value. Start Value shall be 0. Reflect on input shall be done. Reflect on output shall be done. XOR on output shall not be done (XOR value shall be 0).

5.4.5.3 Ephemeris CRC

Requirement reference	
5.4.5.3.1	The "Ephemeris CRC" field shall contain the Ephemeris CRC computed for the ranging source associated with the first ranging source measurement block in the Type 1 Message.
5.4.5.3.2	For a SBAS geostationary satellite, the Ephemeris CRC shall be coded as all zeros.
5.4.5.3.3	The ephemeris CRC generator polynomial shall be: $G(x) = x^{16} + x^{12} + x^5 + 1$
5.4.5.3.4	The CRC information field, $M(x)$, for a given satellite shall be: $M(x) = \sum_{i=1}^n m_i x^{n-i} = m_1 x^{n-1} + m_2 x^{n-2} + \dots + m_n x^0$
5.4.5.3.5	For a GPS satellite, $M(x)$ shall be of length $n = 576$ bits.
5.4.5.3.6	$M(x)$ for a GPS satellite shall be calculated using the first 24 bits from each of Words 3 through 10 of subframes 1, 2 and 3 of the data transmission from that satellite, ANDed with the GPS satellite ephemeris mask shown in table 5.77.
5.4.5.3.7	After the AND operation, $M(x)$ shall be arranged in the order that bytes are transmitted by the GPS satellite, but with each byte ordered least-significant bit first, such that m_1 corresponds to bit 68 of subframe 1 (LSB of subframe 1, word 3), and m_{576} corresponds to bit 287 of subframe 3 (MSB of subframe 3, word 10).
5.4.5.3.8	The CRC shall be ordered such that r_1 is the first bit transmitted and r_{16} is the last bit transmitted.
5.4.5.3.9	The following variables shall be used to compute the CRC-value. Start Value shall be 0. Reflect on input shall be done. Reflect on output shall be done. XOR on output shall not be done (XOR value shall be 0).

Table 5.77: GPS Satellite ephemeris mask

Subframe 1:	Byte 1	Byte 2	Byte 3		Byte 1	Byte 2	Byte 3
Word 3	0000 0000	0000 0000	0000 0011	Word 4	0000 0000	0000 0000	0000 0000
Word 5	0000 0000	0000 0000	0000 0000	Word 6	0000 0000	0000 0000	0000 0000
Word 7	0000 0000	0000 0000	1111 1111	Word 7	1111 1111	1111 1111	1111 1111
Word 9	1111 1111	1111 1111	1111 1111	Word 10	1111 1111	1111 1111	1111 1100
Subframe 2:	Byte 1	Byte 2	Byte 3		Byte 1	Byte 2	Byte 3
Word 3	1111 1111	1111 1111	1111 1111	Word 4	1111 1111	1111 1111	1111 1111
Word 5	1111 1111	1111 1111	1111 1111	Word 6	1111 1111	1111 1111	1111 1111
Word 7	1111 1111	1111 1111	1111 1111	Word 7	1111 1111	1111 1111	1111 1111
Word 9	1111 1111	1111 1111	1111 1111	Word 10	1111 1111	1111 1111	0000 0000
Subframe 3:	Byte 1	Byte 2	Byte 3		Byte 1	Byte 2	Byte 3
Word 3	1111 1111	1111 1111	1111 1111	Word 4	1111 1111	1111 1111	1111 1111
Word 5	1111 1111	1111 1111	1111 1111	Word 6	1111 1111	1111 1111	1111 1111
Word 7	1111 1111	1111 1111	1111 1111	Word 7	1111 1111	1111 1111	1111 1111
Word 9	1111 1111	1111 1111	1111 1111	Word 10	1111 1111	1111 1111	1111 1100

6 General design requirements

The equipment shall meet the requirements of EN 301 842-2 [5] clause 6.

7 Protocol test procedures

7.1 General

The equipment shall meet the requirements of EN 301 842-2 [5] clause 7.1.

7.2 Required test rig

An overview of the PCOs identified as required for the conduct of test cases is illustrated in figure 7.1.

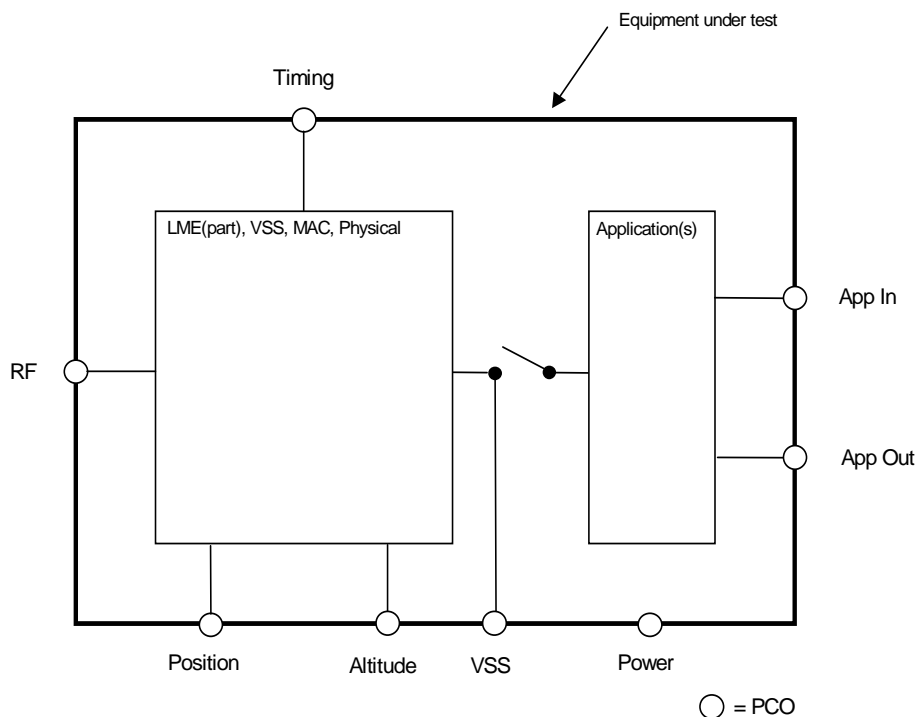

Figure 7.1: Location of PCOs

In addition, it shall be possible to verify that the equipment under test has passed the self test procedure.

The PCOs identified in this figure are each associated with a test set which shall support the following:

RF:

- input to the equipment under test of a single burst or sequence of bursts, of specified content, one or more slots in length, commencing in a slot at a specified time, on a specified channel;
- recording of the time at which a burst containing specified content (per field) is output by the equipment under test, on any of three channels;
- simultaneous input to the equipment of bursts of specified content, commencing in a slot at a specified time, on two separate channels.

Timing:

- input of a reference time source compliant with the requirements of the present document;
- disabling of the input of reference time.

NOTE 1: Disabling of the timing source is required to force the equipment under test into secondary or tertiary timing mode.

NOTE 2: In certain equipment architectures, the reference timing source may be incorporated internally within the equipment under test. Under such conditions, there is no requirement to expose the timing source itself, but a means must be provided to disable it as identified above.

Position:

- input to the equipment under test of a specified geographical position at a specified time;
- input to the equipment under test of position validity/quality to allow determination of position integrity (nic);
- disabling of the position source.

NOTE 3: Disabling of the position source is required to demonstrate that appropriate notification is provided by means of the Navigation Integrity Category (NIC) field.

NOTE 4: In certain equipment architectures, the position source may be incorporated internally into the equipment under test. Under such conditions, manufacturers will be required to perform alternative tests to those specified in the present document to demonstrate correct operation of the position encoding/decoding algorithms. In addition, a means must be provided to disable the position source as stated above.

Altitude:

- input to the equipment under test of a specified altitude at a specified time;
- disabling of the altitude source;
- configuration information identifying whether geometric or barometric altitude is provided.

NOTE 5: Disabling of the altitude source is required to demonstrate that appropriate notification is provided by means of the fixed synchronization burst.

NOTE 6: In certain equipment architectures, the altitude source may be incorporated internally into the equipment under test. Under such conditions, manufacturers will be required to perform alternative tests to those specified in the present document to demonstrate correct operation of the position encoding/decoding algorithms. In addition, a means must be provided to disable the position source as stated above.

VSS:

The VSS User PCO is not normally exposed during operational use of the VDL Mode 4 ADS-B system. It is available only during test mode, in which the internal application(s) are disconnected from the VSS and lower layers, as illustrated above.

The VSS User PCO is intended to provide a means to stimulate the VDL Mode 4 system independently of the internal applications, and to offer a mechanism to use test such features of the VSS sub-layer such as slot selection and reservation conflict processing which could not be tested adequately by any other means. At this PCO, functionality shall be provided to allow the User (i.e. test set) to:

- enable/disable autonomous synch bursts, and control of parameters TV11 min, TV11 max and V11 associated with their transmission;
- maintain a queue of random access transmissions, of user specified content, such that at least one burst is always in the transmit queue;
- establish a sequence of streams of periodic broadcasts, of user specified content, defined by parameters TV11 min, TV11 max, V11, V12, together with Quality of Service parameters Q2a to Q2d, Q4 and Q5;
- cancel an existing sequence of periodic streams;
- establish a sequence of incremental broadcasts, of user specified content, defined by parameters V21, V22, together with Quality of Service parameters Q2a to Q2d, Q4 and Q5;
- receive a notification that a non-zero version number has been detected;
- receive a notification in response to a request for transmission that no slot was available for selection.

AppIn:

Input to the equipment under test of any additional data required to support any internal applications. This interface is specifically used to support tests of TIS-B and FIS-B.

AppOut:

Output from the equipment under test of any data associated with internal application(s). Examples include ADS-B, TIS-B, FIS-B data for output to the crew.

NOTE 7: A display of ADS-B data built into the equipment may represent this PCO.

Power:

Power shall be applied at this PCO in accordance with clauses 7.1.1 and 7.1.2. The facility shall be provided to interrupt the power supply for a period between 150 ms and 15 s, upon an event being signalled from the surrounding test harness.

7.3 Protocol test-suite description methodology

The equipment shall meet the requirements of [5] clause 7.3.

7.4 Detailed protocol test procedures

The test procedures set forth below constitute a satisfactory method of determining the required VDL Mode 4 ground station performance. Although specific test procedures are cited, it is recognized that other methods may be preferred. Such alternate methods may be used if the manufacturer can show that they provide at least equivalent information. Therefore, the procedures cited herein should be used as one criterion in evaluating the acceptability of the alternate procedures.

7.4.1 Test-suite overview

The test-suite overview shown in table 7.1 on the following pages lists the test cases by their name. The second column holds a short description of the test case objective. A cross reference between the test case names and the applicable requirements is provided in annex A.

Table 7.1: Protocol test-suite overview

Test Case Name	Description
ADSB_request_A	To demonstrate that a station which desires another station to transmit a single autonomous synchronization burst will transmit an ADS-B request burst with the sleep and auto bits set to zero.
ADSB_request_B	To demonstrate that a station which desires another station to transmit a single autonomous synchronization burst with a specified variable part, will transmit an ADS-B request burst with sleep=0 and auto=1 and shall include the auto parameters.
ADSB_request_C	To demonstrate that a station which desires another station to transmit synchronization bursts autonomously with the use of sleep mode, will transmit an ADS-B request burst with sleep=1 and auto=0 and shall include the sleep parameters.
ADSB_request_D	To demonstrate that a station which desires another station to transmit synchronization bursts with a specified variable part and with the use of sleep mode, will transmit an ADS-B request burst with sleep=1 and auto=1 and shall include the auto and sleep parameters.
ADSB_reporting	To demonstrate that a station will send at least 12 sync bursts a minute averaged over the two GSCs.
ADSB_request_time	To show that a station requesting the time synchronization information field (information field ID 2) shall only transmit a request to a station that has announced that it is operating with a primary time source (tfom = 0 or 1).
ADSB_priority	To show that information fields 0, 1, 2, 3, 4 and A1 hex have priority over other information fields.
ADSB_TCP_flag_C	To show that a ground station, when configured to respond in this way, will request a mobile which has transmitted a TCP/SVQ flag of zero to transmit a sync burst with a two-slot TCP or SVQ variable part.
ADSB_DOS_A	To demonstrate that a station will broadcast a Directory of Service message with the correct format.
ADSB_Channel_A	To demonstrate that a station will broadcast a channel management message with the correct format.

Test Case Name	Description
ADSB_Channel_B	To demonstrate that a station instructed to cancel its previously issued channel management message will broadcast a channel management message with csid=15, with do pointing to the slot from which cancellation shall begin, and with other subfields the same as the original message.
ADSB_Channel_C	To demonstrate that a station will broadcast a channel management message with repeated script block elements with the correct format.
ADSB_Channel_D	To demonstrate that a station will broadcast a channel management message with a regional multicast with the correct format.
ADSB_Directed_Slot_A	To demonstrate that a station broadcasting a channel management message with a non-zero individual offset for a destination station shall ensure that the slot referred to has been reserved using block protocols or ground quarantine.
ADSB_Basic_Ground_A	To demonstrate that a station will correctly broadcast a sync burst with basic ground information field.
ADSB_UTC_Time_A	To demonstrate that a station will correctly broadcast a sync burst with UTC time information field.
ADSB_Basic_Rec_A	To demonstrate that a station will correctly process a received sync burst with basic information field.
ADSB_High_Dynamic_Rec_A	To demonstrate that a station will correctly process a received sync burst with high dynamic information field.
ADSB_Full_Position_Rec_A	To demonstrate that a station will correctly process a received sync burst with full position information field.
ADSB_Two_Slot_TCP/SVQ_Rec_A	To demonstrate that a station will correctly process a received sync burst with two slot TCP/SVQ information field.
ADSB_Single_Slot_TCP_Rec_A	To demonstrate that a station will correctly process a received sync burst with single slot TCP information field.
ADSB_Single_Slot_SVQ_Rec_A	To demonstrate that a station will correctly process a received sync burst with single slot SVQ information field.
ADSB_Aircraft_Data_Rec_A	To demonstrate that a station will correctly process a received sync burst with Aircraft data information field.
ADSB_High_Resolution_Rec_A	To demonstrate that a station will correctly process a received sync burst with High Resolution information field.
CPR_Encode_Offset	To demonstrate that offset latitude and longitude positions are correctly encoded in the sync burst information fields using the CPR algorithm.
CPR_Decode_Offset	To demonstrate that offset latitude and longitude positions are correctly decoded from the sync burst information fields using the CPR algorithm.
TIS_Manage_C	To demonstrate that a station will transmit management messages once in each TIS-B update period.
TIS_Manage_B	To demonstrate that the transmission of the management message for the following TIS-B period shall not be initiated before all target messages of the current TIS-B period are transmitted.
TIS_Channel_B	To demonstrate that all TIS-B targets for a single TIV are transmitted with the same update period.
TIS_Target_Update_A	To demonstrate that each airborne target message is sent once every update period for each airborne TIV the target is included in.
TIS_Target_Update_B	To demonstrate that each aircraft ground target message is sent once every update period for each ground TIV the target is included in.
TIS_Target_Update_C	To demonstrate that each ground vehicle target message is sent once every update period for each ground TIV the target is included in.
TIS_Target_Update_D	To demonstrate that each aircraft ground target message is sent once every update period for each ground and airborne TIV the target is included in.
TIS_Target_Ground	To demonstrate that for a ground TIV, appropriate target messages are broadcast depending on whether they are identified as either aircraft or ground vehicles.
TIS_Manage_A	To demonstrate that a station will broadcast a management message with the correct format.
TIS_Aircraft_Air_A	To demonstrate that a station will broadcast an aircraft target message (airborne TIV) with the correct format.
TIS_Flight_ID_A	To demonstrate that the flight ID for a target shall be transmitted every 3 TIS-B update periods or better.
TIS_Flight_ID_B	To demonstrate that if more than 1 flight ID is sent, then this will be alternated for the target in question.
TIS_Aircraft_Grd_A	To demonstrate that a station will broadcast aircraft target messages (ground TIV) with the correct format.
TIS_Grd_Veh_A	To demonstrate that a station will broadcast a ground vehicle target messages (ground TIV) with the correct format.

Test Case Name	Description
TIS_Veh_Default_A	To demonstrate that if no information for a target is provided implying that it is an aircraft (Mode A code, callsign, registration marking or emitter category), then it will be regarded as a vehicle target until further information is provided.
FIS_METAR_A	To demonstrate that a station will broadcast a METAR message with the correct format.
FIS_SPECI_A	To demonstrate that a station will broadcast a SPECI message with the correct format.
FIS_METAR_C	To demonstrate that a station will transmit METAR reports once during each update period.
FIS_ATIS_A	To demonstrate that a station will broadcast an ATIS message with the correct format.
FIS_RCN_A	To demonstrate that a station will broadcast an RCN message with the correct format.
FIS_SIGMET_A	To demonstrate that a station will broadcast a SIGMET message with the correct format.
FIS_TSA_CTR_A	To demonstrate that a station will broadcast a TSA message for control zones with the correct format.
FIS_TSA_DNG_A	To demonstrate that a station will broadcast a TSA message for restricted, danger or prohibited zones with the correct format.
FIS_Request_C	To demonstrate that a ground station which receives a broadcast report request message from a mobile that does not reserve slot(s) for the response, will broadcast the information at the required rate.
FIS_Request_D	To demonstrate that a ground station which receives an addressed report request message from a mobile that reserves a specific slot for the response, will broadcast the requested information in the reserved slot.
FIS_Request_E	To demonstrate that a ground station which receives an addressed report request message from a mobile that does not reserve slot(s) for the response, will broadcast the information at the required rate.
FIS_Request_F	To demonstrate that a ground station which receives a broadcast report request message from a mobile that reserves a specific slot for the response, will broadcast the requested information in the reserved slot.
FIS_Queue_A	To demonstrate that a station will correctly manage a queue of targets to be transmitted.
FIS_Slot_A	To demonstrate that a station will transmit FIS-B messages in slots as instructed by the FIS-B server.
FIS_AddInfo_A	To demonstrate that a station passes requests for additional information to the FIS-B server.
FIS_Request_Rec_A	To demonstrate that a station will correctly process a received FIS-B report request message with a null reservation.
FIS_Request_Rec_B	To demonstrate that a station will correctly process a received FIS-B report request message with a unicast reservation.
GNS_Type1_Message_A	To demonstrate that a station will broadcast a GNS-B Type 1 message with the correct format.
GNS_Type2_Message_A	To demonstrate that a station will broadcast a GNS-B Type 2 message with the correct format.
GNS_Type4_Message_A	To demonstrate that a station will broadcast a GNS-B Type 4 message with the correct format.

7.4.2 Declarations

For the performance of the tests, stimuli are applied and test results are observed at the Points of Control and Observation (PCO) as defined in clause 7.2.

7.4.3 Constraints

7.4.3.1 Abbreviations

Abbreviations and other terms for protocol test cases are given in EN 301 842-2 [5] clause 7.4.3.1 unless stated below.

7.4.3.1.1

Subfield mnemonics

Table 7.2: Subfield mnemonics

Mnemonic	Meaning
a	Additional slots
aavl	Airport availability
ac	Aircraft category
a/d	Autonomous/directed flag
adsff	ADS-B fault flag
aflg	Altitude resolution flag
ai	Additional service Information
altr	Altitude rate
anum	Application number
aptf	Approach type flag
apty	Approach type
atis	No of ADS-B targets
auto	Autonomous information
aux	Auxiliary selection
balt	Base altitude
bar	Barometric altitude
b/g	Baro/geo altitude
bgo	Baro/geo offset
blg	Block length
bo	Block offset
br	Block repeat rate
br	Baro rate
brk	Braking action
bs	Block start
bt	Block timeout
c	CRC
call	Callsign
cat	Aircraft category
cav	CAVOK flag
cc	Cloud coverage
ch	Cloud height
cno	Cloud number flag
cprf	CPR format even/odd
crp	Phenomenon / condition reported
csid	Command set ID
csl	Call sign left
csr	Call sign right
cty	Cloud type
d	Destination address
da	Data age
date	Date
day	UTC day
dc	Directory count
dew	Dew point temperature
di	Date issued
DLPDU	Data Link Protocol Data Unit
do	Directed offset
dod	Depth of deposit
dos	Directory of services flag
dt	Directed timeout
dvt	Date valid to
erid	Extended reservation ID
f	Frequency
fc	Frequency count
fidflg	Flight ID flag
fidty	Flight ID type
flag	Flag delimiting burst
fmi	FIS-B message ID
freq	Frequency

Mnemonic	Meaning
frq	Frequency index
ftxt	Free text flag
gr	Geo rate
gs	Ground speed
gsc	Global Signalling Channel (GSC)
gsp	Ground speed
gt	Ground track
gtk	Ground track
h	UTC hour
hd	Holding delay
id	Information field identity
ido	Individual offset
in	Information field
io	Incremental offset
lat	Latitude
lat4	4-bit latitude offset
lat6	6-bit latitude offset
lat8	8-bit latitude offset
lbar	Lower barometric altitude
lg	Length
loci	Location indicator
locl	Local ID
lon	Longitude
lon4	4-bit longitude offset
lon6	6-bit longitude offset
lon8	8-bit longitude offset
long	Reference point longitude
mas	Maximum visibility
masd	Maximum visibility direction
med	Message edition
mi	Message ID
min	UTC minute
mis	Minimum visibility
misd	Minimum visibility direction
mon	UTC month
mrq	Message requested
mxw	max wind flag
n	CTRL length
nd	Negative dither
no	TCP number
nr	Nominal update rate
nsd	Non-standard definition
ntis	No of TIS-B targets
nic	Position navigation integrity category
nucr	Rate uncertainty
nvert	Number of vertices
off	Offset to first reserved slot
ok	Confirm/failure flag
or	Override flag
ori	Originator indicator
oth	Other operational activity
pc	Parameter count
pid	Patch ID
po	Periodic offset
pos	Position
pr	Priority
pr_flag	Plea response flag
prm	VSS user specific parameter
pt	Periodic timeout
pw	Present weather
pwf	Present weather flag
Q1	Priority
Q2a	Slot selection range constraint for level n

Mnemonic	Meaning
Q2b	Slot selection range constraint for level n
Q2c	Slot selection range constraint for level n
Q2d	Slot selection range constraint for level n
Q4	Number of available slots
qfe	QFE
qfef	QFE flag
qnh	QNH
ravl	Runway availability
r-b/a	Requested baro/geo altitude
rlat	Latitude
r-mi	Requested message ID
ro	Response offset
roff	Re-broadcast offset
rso	RVR source
rcon	Runway contamination
rcvr	Receiver control
rd	Reservation data
rdp	Runway deposits
res	Reserved bit
rflg	Radar fusion flag
rri	Reduced runway length
rrw	Reduced runway width
rid	Reservation ID
r-id	Requested information ID subfield
rlg	Longitude
ro	Response offset
roff	Re-broadcast offset
ruf	Runway flag
run	Runway ID
rus	Runway in use
rve	RVR endpoint
rvm	RVR midpoint
rvt	RVR touchdown
rw	Recent weather
rwf	Recent weather flag
s	Source address
sc	Script count
sdf	Source/destination flag
sec	UTC second
sfl	SIGMET flag
sleep	Autonomous monitoring
si	Service information
sit	Service information type
slt	Slot
snr	Secondary reporting rate
sqn	FIS-B sequence number
sr	Script rate
ss	State of the sea
ssf	Sea flag
sst	Sea surface temperature
st	Status
styp	Script duration type
sz	Size
tacc	TIS-B target resolution
tag	Time stamp
tem	Temperature
tqc	TCP/SVQ change flag
tflg	Target identifier flag
tfom	Time figure of merit
ti	Time
tid	Target Identifier
tind	Turn indication
tivid	TIV ID

Mnemonic	Meaning
tmi	TIS-B message ID
tran	Transition time
trd	TREND report flag
trmt	Transmit control
ttg	Time to go
TV11max	Reservation hold time maximum value
TV11min	Reservation hold time minimum value
tvf	Time valid to
txd	Transmission definition index
txt	Free text message
typ	TCP type
ubar	Upper barometric altitude
ucid	UCTRL identity
up	Update period
vdif	Variable wind direction from
vdit	Variable wind direction to
vel	Maximum sleep velocity
ver	Version number
vers	FIS-B version ID
vlat	Vertex latitude
vlg	Vertex longitude
vt	Timeout
V11	Nominal periodic rate
wdi	Wind direction
wgi	Wind gust indicator
ws	Wind shear
wsf	Wind shear flag
wsp	Wind speed
yr	UTC year

7.4.3.1.2 Station addresses and positions

Station addresses are referred to in the test cases in the following format:

add_A = address of the station under test (station A);

add_B = address of simulated station B (simulated by the test equipment);

add_C = address of simulated station C;

with the pattern continuing for other stations. A simulated ground station is normally named G, with address "add_G".

The test station (station A) and other simulated stations are assumed to be at 0° latitude and at 0° longitude, unless otherwise specified. The positions of other stations are given in terms of the direction (East, E, is used for all cases) and distance in nautical miles with respect to the position of station A.

The test station (station A) and other simulated stations are assumed to be at an altitude of zero feet, unless otherwise specified.

The following functions:

lat:= CPR_LAT(y);

lon:= CPR_LON(x);

are used to indicate that the given position will need to be encoded using the CPR encoding algorithm, currently defined in the VDL Mode 4 Technical Manual [1].

For example, the encoded position of the test station (station A) is:

```
lat:= CPR_LAT(0);
```

```
lon:= CPR_LON(0);
```

while the encoded position of a simulated station B, that is 325 NM away from A, will be expressed as:

```
lat:= CPR_LAT(0);
```

```
lon:= CPR_LON(E 325 NM).
```

The encoded offsets are written in the test scripts as follows:

```
lat4:= CPR_LAT4(y);
```

```
lon4:= CPR_LON4(x);
```

```
lat6:= CPR_LAT6(y);
```

```
lon6:= CPR_LON6(x);
```

```
lat8:= CPR_LAT8(y);
```

```
lon8:= CPR_LON8(x).
```

7.4.3.1.3 Tables of values for use in CPR test cases

The following tables are used in the CPR test cases.

Table 7.3: Void

Table 7.4: Key to CPR encoding table in following clause

Table heading	Description
latitude	latitude to be encoded.
longitude	longitude to be encoded.
cpr type	CPR type of position report.
lat enc	encoded latitude for transmission in fixed part of sync burst.
lon enc	encoded longitude for transmission in fixed part of sync burst.
pid enc	encoded patch id for transmission in variable part of sync burst.
lat4(1-3)	encoded 4-bit high resolution latitude offset for transmission in variable part of sync burst.
lat4(4)	encoded 4-bit high resolution latitude offset sign for transmission in variable part of sync burst.
lat6(1-5)	encoded 6-bit high resolution latitude offset for transmission in variable part of sync burst.
lat6(6)	encoded 6-bit high resolution latitude offset sign for transmission in variable part of sync burst.
lat8(1-7)	encoded 8-bit high resolution latitude offset for transmission in variable part of sync burst.
lat8(8)	encoded 8-bit high resolution latitude offset sign for transmission in variable part of sync burst.
lat4(1-3)	encoded 4-bit high resolution longitude offset for transmission in variable part of sync burst.
lat4(4)	encoded 4-bit high resolution longitude offset sign for transmission in variable part of sync burst.
lat6(1-5)	encoded 6-bit high resolution longitude offset for transmission in variable part of sync burst.
lat6(6)	encoded 6-bit high resolution longitude offset sign for transmission in variable part of sync burst.
lat8(1-7)	encoded 8-bit high resolution longitude offset for transmission in variable part of sync burst.
lat8(8)	encoded 8-bit high resolution longitude offset sign for transmission in variable part of sync burst.

7.4.3.1.3.1 Table of test values for CPR position report encoding CPR_ENC_TABLE (row, column) (CE(r, c))

(For the key to this table see the clause above.)

The CPR test values have been designed assuming an aircraft travelling at constant velocity in a north-easterly direction and transmitting its position with a CPR report every 10 s. The receiving station is assumed to miss many of the transmitted reports, and in a way which allows this test to pass through all the various operations of the state machine during the decoding process (see table in clause 5.2.4.3.2.7). The missed positions, which are not relevant here, are excluded from the encoding table below and from the decoding table in clause 5.2.4.3.2.7 for clarity. The target is assumed to become unreachable during the elapsed time represented by the missed reports (gaps in the table), due to expiration of L1.

The input latitude and longitude values in the first two columns of the encoding table below (and in the first four columns of the table in clause 5.2.4.3.2.7) vary for the purpose of the test up to the fourth decimal place, but are required to be accurate to 9 decimal places as shown, in order to achieve the given encoded values.

Table 7.5: Table of test values for CPR position report encoding CPR_ENC_TABLE (row, column) (CE(r, c))

latitude	longitude	cpr_type	lat_enc	lon_enc	pid_enc	lat4(1-3)	lat4(4)	lat6(1-5)	lat6(6)	lat8(1-7)	lat8(8)	lon4(1-3)	lon4(4)	lon6(1-5)	lon6(6)	lon8(1-7)	lon8(8)
12,855700000	-0,815000000	0	1 169	15 085	70	6	1	25	1	104	1	2	0	8	0	32	0
12,872000000	-0,798700000	1	1 030	15 147	69	5	0	21	0	85	0	3	1	11	1	47	1
12,888300000	-0,782400000	0	1 183	15 137	70	3	0	15	0	61	0	3	0	12	0	51	0
12,904600000	-0,766100000	1	1 043	15 198	69	5	0	22	0	90	0	5	0	23	0	95	0
12,920900000	-0,749800000	0	1 196	15 189	70	2	1	7	1	28	1	4	0	17	0	70	0
12,953500000	-0,717200000	0	1 209	15 241	70	6	1	28	1	116	1	5	0	22	0	89	0
12,969800000	-0,700900000	1	1 069	15 299	69	6	0	25	0	101	0	7	0	30	0	125	0
13,002400000	-0,668300000	1	1 082	15 349	69	6	0	26	0	107	0	1	0	3	0	13	0
13,051300000	-0,619400000	0	1 250	15 396	70	7	0	31	0	125	0	6	1	26	1	108	1
13,100200000	-0,570500000	1	1 121	15 500	69	7	0	30	0	123	0	4	1	17	1	70	1
13,165400000	-0,505300000	1	1 146	15 601	69	7	1	29	1	121	1	2	1	10	1	40	1
13,279500000	-0,391200000	0	1 343	15 760	70	1	0	3	0	11	0	1	0	6	0	25	0
13,312100000	-0,358600000	0	1 356	15 812	70	4	1	19	1	77	1	2	0	11	0	44	0
13,328400000	-0,342300000	1	1 211	15 853	69	5	1	23	1	94	1	5	1	23	1	93	1
13,409900000	-0,260800000	0	1 396	15 968	70	5	1	22	1	90	1	6	0	25	0	102	0
13,426200000	-0,244500000	1	1 250	16 005	69	4	1	19	1	78	1	4	0	19	0	79	0
13,442500000	-0,228200000	0	1 410	16 020	70	4	0	18	0	75	0	7	0	29	0	121	0
13,475100000	-0,195600000	0	1 423	16 071	70	1	1	3	1	14	1	6	1	28	1	114	1
13,491400000	-0,179300000	1	1 276	16 106	69	4	1	16	1	67	1	6	0	27	0	109	0
13,507700000	-0,163000000	0	1 436	16 123	70	6	1	25	1	102	1	5	1	23	1	95	1
13,524000000	-0,146700000	1	1 289	16 163	68	3	1	15	1	62	1	4	0	19	0	79	0
13,540300000	-0,130400000	0	1 450	16 181	69	3	0	15	0	63	0	3	1	15	1	60	1
13,556600000	-0,114100000	1	1 302	16 212	68	3	1	14	1	56	1	5	0	22	0	90	0
13,589200000	-0,081500000	1	1 315	16 261	68	3	1	12	1	51	1	6	0	24	0	100	0
13,654400000	-0,016300000	1	1 341	16 359	68	2	1	10	1	40	1	7	0	30	0	122	0
13,735900000	0,065200000	0	1 530	101	36	2	0	9	0	38	0	2	0	7	0	30	0
13,850000000	0,179300000	1	1 419	269	36	0	1	2	1	8	1	4	1	17	1	68	1
13,866300000	0,195600000	0	1 583	303	36	3	1	15	1	63	1	5	0	22	0	89	0
13,996700000	0,326000000	0	1 637	504	36	5	0	22	0	89	0	6	1	26	1	105	1
14,013000000	0,342300000	1	1 484	514	36	1	0	5	0	19	0	1	1	4	1	15	1
14,143400000	0,472700000	1	1 536	710	36	2	0	10	0	40	0	2	0	7	0	28	0
14,208600000	0,537900000	1	1 562	808	36	3	0	12	0	51	0	3	0	12	0	50	0
14,290100000	0,619400000	0	1 757	958	36	3	0	13	0	52	0	5	1	24	1	98	1
14,322700000	0,652000000	0	1 770	1 009	36	2	1	9	1	37	1	2	0	11	0	44	0
14,404200000	0,733500000	1	1 640	1 102	36	5	0	20	0	83	0	6	0	28	0	114	0
14,436800000	0,766100000	1	1 653	1 151	36	5	0	22	0	89	0	7	0	30	0	125	0
14,518300000	0,847600000	0	1 850	1 311	36	3	1	15	1	62	1	7	1	30	1	121	1
14,550900000	0,880200000	0	1 864	1 362	36	6	0	25	0	103	0	1	0	5	0	21	0
14,632400000	0,961700000	1	1 731	1 444	36	7	0	29	0	121	0	4	1	16	1	65	1
14,713900000	1,043200000	0	1 930	1 614	36	5	1	21	1	87	1	2	1	8	1	32	1
14,746500000	1,075800000	0	1 944	1 665	36	4	0	19	0	78	0	6	0	27	0	110	0
14,762800000	1,092100000	1	1 782	1 640	36	6	1	27	1	112	1	1	1	5	1	22	1
14,876900000	1,206200000	0	1 997	1 866	36	1	1	6	1	23	1	5	1	21	1	85	1
14,893200000	1,222500000	1	1 834	1 836	36	5	1	22	1	90	1	1	0	5	0	20	0
15,007300000	1,336600000	0	2 050	2 068	36	7	1	30	1	124	1	1	1	6	1	25	1
15,088800000	1,418100000	1	1 912	2 130	36	3	1	14	1	58	1	5	0	21	0	85	0
15,121400000	1,450700000	1	1 925	2 179	36	3	1	13	1	53	1	5	0	23	0	95	0

latitude	longitude	cpr_type	lat_enc	lon_enc	pid_enc	lat4(1-3)	lat4(4)	lat6(1-5)	lat6(6)	lat8(1-7)	lat8(8)	lon4(1-3)	lon4(4)	lon6(1-5)	lon6(6)	lon8(1-7)	lon8(8)
15,154000000	1,483300000	1	1 938	2 228	36	3	1	12	1	47	1	6	0	26	0	106	0
15,235500000	1,564800000	0	2 144	2 421	36	1	0	4	0	16	0	3	1	12	1	48	1
15,268100000	1,597400000	0	2 157	2 472	36	4	1	18	1	73	1	5	0	23	0	94	0
15,349600000	1,678900000	1	2 016	2 521	36	1	1	4	1	15	1	5	1	20	1	84	1
15,365900000	1,695200000	0	2 197	2 623	36	5	1	21	1	85	1	1	0	3	0	12	0
15,480000000	1,809300000	1	2 068	2 717	36	0	0	2	0	6	0	2	1	10	1	41	1
15,496300000	1,825600000	0	2 251	2 825	36	4	0	16	0	67	0	4	0	17	0	71	0
15,610400000	1,939700000	1	2 120	2 913	36	2	0	7	0	28	0	0	0	0	0	2	0
15,626700000	1,956000000	0	2 304	3 026	36	2	1	8	1	34	1	7	1	30	1	123	1
15,740800000	2,070100000	1	2 172	3 109	36	3	0	12	0	49	0	2	0	11	0	45	0
15,757100000	2,086400000	0	2 358	3 228	36	7	0	29	0	119	0	4	1	16	1	64	1
15,871200000	2,200500000	1	2 224	3 305	36	4	0	17	0	71	0	5	0	21	0	87	0
15,887500000	2,216800000	0	2 411	3 430	36	1	0	4	0	17	0	0	1	1	1	4	1
15,903800000	2,233100000	1	2 237	3 354	36	4	0	19	0	76	0	5	0	24	0	98	0
15,920100000	2,249400000	0	2 424	3 480	36	4	1	17	1	71	1	6	1	28	1	117	1
19,098600000	5,427900000	1	3 509	8 151	36	5	0	23	0	94	0	7	1	30	1	123	1
19,114900000	5,444200000	0	3 733	8 424	36	6	0	28	0	114	0	4	0	17	0	71	0
19,131200000	5,460500000	1	3 522	8 200	36	5	0	24	0	99	0	6	1	27	1	112	1
19,147500000	5,476800000	0	3 746	8 474	36	1	0	6	0	25	0	2	1	10	1	41	1
19,163800000	5,493100000	1	3 535	7 999	36	6	0	26	0	105	0	6	1	26	1	106	1
19,180100000	5,509400000	0	3 759	8 274	36	4	1	16	1	64	1	2	0	7	0	31	0
23,483300000	9,812600000	1	1 159	14 290	72	4	1	18	1	73	1	3	0	15	0	60	0
23,499600000	9,828900000	0	1 433	14 761	72	1	1	5	1	22	1	3	0	13	0	52	0
23,515900000	9,845200000	1	1 172	14 337	72	4	1	17	1	68	1	3	1	15	1	60	1
23,532200000	9,861500000	0	1 446	14 361	72	6	1	27	1	111	1	0	0	2	0	7	0
23,548500000	9,877800000	1	1 185	13 935	72	3	1	15	1	63	1	3	1	12	1	48	1
27,167100000	13,496400000	0	2 935	3 271	73	1	0	4	0	18	0	5	1	22	1	91	1
27,183400000	13,512700000	1	2 632	2 680	73	5	1	24	1	99	1	2	1	10	1	39	1
27,199700000	13,529000000	0	2 948	3 319	73	4	1	17	1	70	1	2	0	10	0	43	0
27,216000000	13,545300000	1	2 645	2 726	73	5	1	23	1	94	1	2	1	9	1	37	1
27,232300000	13,561600000	0	2 962	2 749	73	5	0	23	0	95	0	2	1	9	1	36	1
27,248600000	13,577900000	1	2 658	2 154	73	5	1	22	1	89	1	3	1	14	1	58	1
30,361900000	16,691200000	0	148	7 164	109	3	1	12	1	50	1	3	1	15	1	63	1
30,378200000	16,707500000	1	3 904	6 427	73	4	1	20	1	82	1	1	0	5	0	22	0
30,394500000	16,723800000	0	162	7 210	109	6	0	28	0	115	0	3	1	15	1	61	1
30,508600000	16,837900000	1	3 956	6 605	73	3	1	15	1	60	1	1	0	4	0	14	0
30,524900000	16,854200000	0	215	6 627	109	1	0	3	0	14	0	3	1	12	1	50	1
30,541200000	16,870500000	1	3 969	5 882	73	3	1	13	1	55	1	4	0	18	0	76	0
30,557500000	16,886800000	0	228	6 672	109	4	1	18	1	75	1	4	0	18	0	75	0
33,361100000	19,690400000	0	1 376	10 499	109	5	1	23	1	94	1	4	1	20	1	81	1
33,377400000	19,706700000	1	1 003	9 625	109	5	1	23	1	96	1	3	0	15	0	63	0
33,393700000	19,723000000	0	1 390	10 544	109	4	0	17	0	71	0	2	0	11	0	44	0
33,507800000	19,837100000	1	1 055	9 797	109	4	1	18	1	74	1	2	0	9	0	39	0
33,524100000	19,853400000	0	1 443	9 818	109	2	1	7	1	30	1	5	1	22	1	91	1
33,540400000	19,869700000	1	1 068	8 936	109	4	1	17	1	69	1	5	0	23	0	93	0

latitude	longitude	cpr_type	lat_enc	lon_enc	pid_enc	lat4(1-3)	lat4(4)	lat6(1-5)	lat6(6)	lat8(1-7)	lat8(8)	lon4(1-3)	lon4(4)	lon6(1-5)	lon6(6)	lon8(1-7)	lon8(8)
33,556700000	19,886000000	0	1 456	9 861	109	7	1	29	1	119	1	5	1	24	1	97	1
36,132100000	22,461400000	1	2 100	12 238	109	1	1	6	1	23	1	1	1	4	1	16	1
36,148400000	22,477700000	0	2 518	13 282	109	3	0	14	0	58	0	3	0	15	0	62	0
36,164700000	22,494000000	1	2 113	12 280	109	1	1	4	1	18	1	6	0	25	0	100	0
36,278800000	22,608100000	0	2 571	13 454	109	2	1	10	1	43	1	2	0	9	0	38	0
36,295100000	22,624400000	1	2 165	11 416	109	0	0	1	0	3	0	2	1	10	1	42	1
36,311400000	22,640700000	0	2 585	12 467	109	7	0	30	0	122	0	7	0	29	0	118	0
36,327700000	22,657000000	1	2 178	11 456	109	0	0	2	0	9	0	3	1	14	1	56	1
38,723800000	25,053100000	1	3 132	14 400	109	1	0	5	0	22	0	5	1	23	1	94	1
38,740100000	25,069400000	0	3 579	15 561	109	1	1	4	1	18	1	4	1	16	1	67	1
38,756400000	25,085700000	1	3 145	14 440	109	2	0	7	0	27	0	6	1	26	1	108	1
38,870500000	25,199800000	0	3 632	15 727	109	7	1	29	1	119	1	6	1	26	1	108	1
38,886800000	25,216100000	1	3 197	13 453	109	3	0	12	0	49	0	2	1	7	1	28	1
38,903100000	25,232400000	0	3 646	14 621	109	3	0	11	0	46	0	4	0	20	0	81	0
38,919400000	25,248700000	1	3 210	13 492	109	3	0	13	0	54	0	4	0	20	0	81	0
41,185100000	27,514400000	0	485	1 042	146	4	1	19	1	76	1	5	0	23	0	94	0
41,201400000	27,530700000	1	23	16 192	145	4	1	19	1	78	1	3	0	13	0	55	0
41,217700000	27,547000000	0	499	1 082	146	5	0	22	0	89	0	4	0	19	0	79	0
41,331800000	27,661100000	1	75	16 346	145	3	1	14	1	57	1	1	1	5	1	19	1
41,348100000	27,677400000	0	552	16 365	145	1	1	3	1	12	1	5	1	22	1	92	1
41,364400000	27,693700000	1	88	15 124	145	3	1	13	1	51	1	5	1	22	1	90	1
41,380700000	27,710000000	0	565	21	146	6	1	25	1	101	1	1	0	4	0	17	0
43,532300000	29,861600000	0	1 446	2 567	146	7	1	30	1	121	1	4	0	16	0	65	0
43,548600000	29,877900000	1	958	1 226	146	3	0	13	0	54	0	5	1	21	1	85	1
43,564900000	29,894200000	0	1 460	2 605	146	2	0	11	0	44	0	4	1	20	1	80	1
43,679000000	30,008300000	1	1 010	1 375	146	4	0	18	0	76	0	4	0	19	0	78	0
43,695300000	30,024600000	0	1 513	1 393	146	3	1	14	1	57	1	3	1	15	1	60	1
43,711600000	30,040900000	1	1 023	45	146	4	0	20	0	81	0	5	0	20	0	84	0
43,727900000	30,057200000	0	1 527	1 430	146	6	0	26	0	108	0	5	1	20	1	83	1
45,781700000	32,111000000	1	1 847	2 306	146	2	0	10	0	41	0	5	0	23	0	93	0
45,798000000	32,127300000	0	2 374	3 785	146	4	1	17	1	71	1	7	1	31	1	126	1
45,814300000	32,143600000	1	1 860	2 341	146	3	0	11	0	46	0	3	1	15	1	61	1
45,928400000	32,257700000	0	2 428	3 934	146	4	0	20	0	81	0	2	0	9	0	37	0
45,944700000	32,274000000	1	1 912	1 015	146	4	0	17	0	68	0	1	0	5	0	19	0
45,961000000	32,290300000	0	2 441	2 501	146	0	1	2	1	7	1	7	1	29	1	118	1
45,977300000	32,306600000	1	1 925	1 049	146	4	0	18	0	73	0	1	1	3	1	12	1
47,949600000	34,278900000	1	2 710	3 113	146	1	0	4	0	17	0	6	1	27	1	111	1
47,965900000	34,295200000	0	3 262	4 691	146	1	1	2	1	9	1	3	1	13	1	55	1
47,982200000	34,311500000	1	2 723	3 148	146	1	0	5	0	22	0	6	0	27	0	111	0
48,096300000	34,425600000	0	3 315	4 834	146	6	1	27	1	110	1	5	0	22	0	91	0
48,112600000	34,441900000	1	2 775	1 717	146	2	0	11	0	43	0	5	0	21	0	87	0
48,128900000	34,458200000	0	3 329	3 301	146	3	0	13	0	55	0	2	1	7	1	28	1
48,145200000	34,474500000	1	2 788	1 749	146	3	0	12	0	49	0	4	1	18	1	75	1

7.4.3.1.3.2 CPR test value tolerances

The number of decimal places afforded to the decoded latitude and longitude values in the last eight columns of the table in clause 5.2.4.3.2.7 varies according to the resolution expected from the decoding algorithm (see table 7.6). When using the table in clause 5.2.4.3.2.7 to test the validity of an installed algorithm, the given decoded latitude and longitude values should be interpreted using the tolerances given in the last column of table 7.6.

Table 7.6: CPR test value tolerances

Decoded Parameter	Total number of bits used to encode	Approximate max decoded error (degrees)	Number of decimal places given to decoded values	Tolerance to be given on decoded values during test of algorithm (degrees)
Decoded lat	12	$\pm 0,0012$	4	$\pm 0,0003$
Decoded lon	14	$\pm 0,0012^*$	5	$\pm 0,0003$
Decoded 4-bit lat	16	$\pm 0,000076$	6	$\pm 0,00002$
Decoded 4-bit lon	18	$\pm 0,000076^*$	6	$\pm 0,00002$
Decoded 6-bit lat	18	$\pm 0,000019$	6	$\pm 0,000005$
Decoded 6-bit lon	20	$\pm 0,000019^*$	7	$\pm 0,000005$
Decoded 8-bit lat	20	$\pm 0,0000048$	7	$\pm 0,0000012$
Decoded 8-bit lon	22	$\pm 0,0000048^*$	7	$\pm 0,0000012$
NOTE 1: The figures marked "*" take into account that in the case of longitude the maximum error in the decoded value is up to four times greater at high latitudes.				
NOTE 2: Since the figures given in the table in clause 7.4.3.1.5 are designed to be used to test the CPR algorithm, the decoded figures in the last eight columns of the table are given to more decimal places than the number of decimal places to which the decoded results may be relied upon for position reporting.				

7.4.3.1.3.3 Key to CPR decoding table in following clause

Table 7.7: Key to CPR decoding table in following clause

Table heading	Description
lat sut	latitude of the station under test.
lon sut	longitude of the station under test.
lat last	input latitude from last position.
lat prev	input latitude from previous (last but one) position.
lon last	input longitude from last position.
lon prev	input longitude from previous (last but one) position.
tl	input CPR type from last position.
tp	input CPR type from previous (last but one) position.
tr	indicates 1 if the two points straddle a transition latitude (and 0 otherwise).
i	initial state in CPR state machine.
p	indicates 1 if a patch ID is available for decoding (and 0 otherwise).
tim	time in s since last report received.
o	indicates whether the receiver knows its own position.
op	state machine operation used (see Op field in tables in ED-108 Part 1 Appendix C).
cal	calculation determined by state machine operation.
f	final state in CPR state machine.
decoded lat	decoded latitude without high resolution offset.
decoded lon	decoded longitude without high resolution offset.
decoded 4-bit lat	decoded latitude with 4-bit high resolution offset.
decoded 4-bit lon	decoded longitude with 4-bit high resolution offset.
decoded 6-bit lat	decoded latitude with 6-bit high resolution offset.
decoded 6-bit lon	decoded longitude with 6-bit high resolution offset.
decoded 8-bit lat	decoded latitude with 8-bit high resolution offset.
decoded 8-bit lon	decoded longitude with 8-bit high resolution offset.

7.4.3.1.3.4 Table of test values for CPR position report decoding CPR_DEC_TABLE (row, column) (CD(r, c))

(For the key to this table see the clause above.)

The encoding for the latitude and longitude values contained in the first four columns of the decoding table below is given in the encoding table in clause 5.2.4.3.2.4.

The decoding operation used in the table below is determined by the state machine tables in clauses 5.2.4.3.2.1 and 5.2.4.3.2.2, and referred to in this table using the column with heading "op". The time since a report was last received is indicated by the column headed "tim". When plotted, the decoded positions form a straight line in a north-easterly direction (allowing for the expected decoding errors), with gaps in the line corresponding to the missed reports. The position of the station under test is varied, since this must remain within plus or minus 300.5 NM of the received position for local decode to be carried out (which uses the position of the station under test as a reference).

NOTE: Although a ground station is expected to be capable of operation in a range of locations, it is recognized that variation of the position of the ground station as described in this test is unrealistic. A future version of this standard may contain a set of test values that do not require variation of the input of ground station's own position.

Table 7.8: Table of test values for CPR position report decoding CPR_DEC_TABLE (row, column) (CD(r, c))

lat sut	lon sut	lat last	lat prev	lon last	lon prev	tl	tp	tr	i	p	tim	o	op	cal	f	decoded lat	decoded lon	decoded 4-bit lat	decoded 4-bit lon	decoded 6-bit lat	decoded 6-bit lon	decoded 8-bit lat	decoded 8-bit lon
12,9	-0,8	12,855700000	-	-0,815000000	-	0	-	-	1	n	-	n	1c	NO	2	NO CALC	NO CALC	NO CALC	NO CALC	NO CALC	NO CALC	NO CALC	NO CALC
12,9	-0,8	12,872000000	12,855700000	-0,798700000	-0,815000000	1	0	0	2	n	10	n	2k	GL	4	12,8728	-0,79882	12,871944	-0,798681	12,871991	-0,7987048	12,8720009	-0,7986998
12,9	-0,8	12,888300000	12,872000000	-0,782400000	-0,798700000	0	1	0	4	n	10	n	4i	GL	4	12,8889	-0,78227	12,888366	-0,782409	12,888298	-0,7823958	12,8883024	-0,7824004
12,9	-0,8	12,904600000	12,888300000	-0,766100000	-0,782400000	1	0	0	4	n	10	n	4q	GL	4	12,9055	-0,76586	12,904597	-0,766089	12,904603	-0,7660982	12,9046045	-0,7661002
12,9	-0,7	12,920900000	12,904600000	-0,749800000	-0,766100000	0	1	0	4	n	10	n	4i	GL	4	12,9206	-0,74963	12,920984	-0,749807	12,920911	-0,7497994	12,9209041	-0,7498003
13,0	-0,7	12,953500000	12,920900000	-0,717200000	-0,749800000	0	0	0	4	n	20	n	4g	L2	4	12,9524	-0,71698	12,953428	-0,717204	12,953484	-0,7172029	12,9534962	-0,7172001
13,0	-0,7	12,969800000	12,953500000	-0,700900000	-0,717200000	1	0	0	4	n	10	n	4q	GL	4	12,9708	-0,70058	12,969724	-0,700906	12,969788	-0,7008955	12,9698019	-0,7009008
13,0	-0,7	13,002400000	12,969800000	-0,668300000	-0,700900000	1	1	0	4	n	20	n	4r	L2	4	13,0035	-0,66827	13,002377	-0,668314	13,002400	-0,6682993	13,0023956	-0,6683011
13,1	-0,6	13,051300000	13,002400000	-0,619400000	-0,668300000	0	1	0	4	n	30	n	4i	GL	4	13,0525	-0,61967	13,051282	-0,619398	13,051282	-0,6194034	13,0513013	-0,6193998
13,1	-0,6	13,100200000	13,051300000	-0,570500000	-0,619400000	1	0	0	4	n	30	n	4q	GL	4	13,1014	-0,57068	13,100157	-0,570493	13,100197	-0,5705004	13,1001965	-0,5704995
13,2	-0,5	13,165400000	13,100200000	-0,505300000	-0,570500000	1	1	0	4	n	40	n	4t	L2	4	13,1642	-0,50540	13,165463	-0,505310	13,165382	-0,5052977	13,1654038	-0,5053002
13,3	-0,4	13,279500000	13,165400000	-0,391200000	-0,505300000	0	1	0	4	n	70	n	4k	NO	2	NO CALC	NO CALC	NO CALC	NO CALC	NO CALC	NO CALC	NO CALC	NO CALC
13,3	-0,4	13,312100000	13,279500000	-0,358600000	-0,391200000	0	0	0	2	n	20	n	2e	NO	2	NO CALC	NO CALC	NO CALC	NO CALC	NO CALC	NO CALC	NO CALC	NO CALC
13,3	-0,3	13,328400000	13,312100000	-0,342300000	-0,358600000	1	0	0	2	n	10	n	2k	GL	4	13,3275	-0,34254	13,328370	-0,342305	13,328404	-0,3422961	13,3284021	-0,3422992
13,4	-0,3	13,409900000	13,328400000	-0,260800000	-0,342300000	0	1	0	4	n	50	n	4j	L2	4	13,4090	-0,26055	13,409908	-0,260818	13,409902	-0,2608020	13,4099007	-0,2608009
13,4	-0,2	13,426200000	13,409900000	-0,244500000	-0,260800000	1	0	0	4	n	10	y	4l	GL	4	13,4254	-0,24430	13,426149	-0,244484	13,426201	-0,2444972	13,4262030	-0,2445002
13,4	-0,2	13,442500000	13,426200000	-0,228200000	-0,244500000	0	1	0	4	n	10	y	4d	GL	4	13,4432	-0,22790	13,442526	-0,228216	13,442514	-0,2281954	13,4425024	-0,2282008
13,5	-0,2	13,475100000	13,442500000	-0,195600000	-0,228200000	0	0	0	4	n	10	y	4b	L2	4	13,4750	-0,19588	13,475144	-0,195613	13,475088	-0,1955990	13,4751041	-0,1956007
13,5	-0,2	13,491400000	13,475100000	-0,179300000	-0,195600000	1	0	0	4	n	10	y	4l	GL	4	13,4907	-0,17902	13,491455	-0,179300	13,491386	-0,1793049	13,4914004	-0,1793008
13,5	-0,2	13,507700000	13,491400000	-0,163000000	-0,179300000	0	1	0	4	n	10	y	4d	GL	4	13,5067	-0,16324	13,507762	-0,163011	13,507700	-0,1630025	13,5076962	-0,1630006
13,5	-0,1	13,524000000	13,507700000	-0,146700000	-0,163000000	1	0	1	4	n	10	y	4z	L2	4	13,5234	-0,14649	13,523929	-0,146684	13,523999	-0,1466974	13,5240040	-0,1467004
13,5	-0,1	13,540300000	13,524000000	-0,130400000	-0,146700000	0	1	0	4	n	10	y	4d	GL	4	13,5409	-0,13055	13,540380	-0,130413	13,540313	-0,1303950	13,5402978	-0,1303987
13,6	-0,1	13,556600000	13,540300000	-0,114100000	-0,130400000	1	0	0	4	n	10	y	4l	GL	4	13,5560	-0,11387	13,556582	-0,114103	13,556611	-0,1141015	13,5565977	-0,1141012
13,6	-0,1	13,589200000	13,556600000	-0,081500000	-0,114100000	1	1	0	4	n	10	y	4m	L2	4	13,5887	-0,08124	13,589235	-0,081523	13,589183	-0,0814950	13,5892013	-0,0814994
13,7	0,0	13,654400000	13,589200000	-0,016300000	-0,081500000	1	1	0	4	n	40	y	4o	L2	4	13,6540	-0,01598	13,654362	-0,016314	13,654408	-0,0163033	13,6543987	-0,0163009
13,7	0,1	13,735900000	13,654400000	0,065200000	-0,016300000	0	1	0	4	n	50	y	4e	L2	4	13,7363	0,06528	13,735915	0,065183	13,735909	0,0652027	13,7358984	0,0651994
13,9	0,2	13,850000000	13,735900000	0,179300000	0,065200000	1	0	0	4	n	70	y	4p	L1	3	13,8499	0,17912	13,849922	0,179312	13,850003	0,1793040	13,8500006	0,1792996
13,9	0,2	13,866300000	13,850000000	0,195600000	0,179300000	0	1	0	3	n	10	y	3c	GL	4	13,8657	0,19583	13,866213	0,195596	13,866281	0,1955978	13,8662956	0,1956006
14,0	0,3	13,996700000	13,866300000	0,326000000	0,195600000	0	0	0	4	n	80	y	4f	L1	3	13,9976	0,32573	13,996686	0,326009	13,996691	0,3260032	13,9967023	0,3259994
14,0	0,3	14,013000000	13,996700000	0,342300000	0,326000000	1	0	0	3	n	10	y	3h	GL	4	14,0132	0,34226	14,013007	0,342309	14,012984	0,3423046	14,0129989	0,3423010
14,1	0,5	14,143400000	14,013000000	0,472700000	0,342300000	1	1	0	4	n	80	n	4u	NO	2	NO CALC	NO CALC	NO CALC	NO CALC	NO CALC	NO CALC	NO CALC	NO CALC
14,2	0,5	14,208600000	14,143400000	0,537900000	0,472700000	1	1	0	2	n	40	y	2m	NO	2	NO CALC	NO CALC	NO CALC	NO CALC	NO CALC	NO CALC	NO CALC	NO CALC
14,3	0,6	14,290100000	14,208600000	0,619400000	0,537900000	0	1	0	2	n	50	y	2d	L1	3	14,2906	0,61915	14,290075	0,619381	14,290086	0,6193999	14,2900984	0,6193991
14,3	0,7	14,322700000	14,290100000	0,652000000	0,619400000	0	0	0	3	n	20	y	3b	L1	3	14,3223	0,65211	14,322693	0,652018	14,322699	0,6519960	14,3227000	0,6519987
14,4	0,7	14,404200000	14,322700000	0,733500000	0,652000000	1	0	0	3	n	50	y	3i	L1	3	14,4050	0,73380	14,404126	0,733513	14,404213	0,7334976	14,4042028	0,7334995
14,4	0,8	14,436800000	14,404200000	0,766100000	0,733500000	1	1	0	3	n	20	y	3j	L1	3	14,4377	0,76643	14,436780	0,766093	14,436785	0,7661042	14,4367965	0,7660987
14,5	0,8	14,518300000	14,436800000	0,847600000	0,766100000	0	1	0	3	n	50	y	3d	L1	3	14,5177	0,84729	14,518228	0,847615	14,518295	0,8476042	14,5183006	0,8475994
14,6	0,9	14,550900000	14,518300000	0,880200000	0,847600000	0	0	0	3	n	20	n	3e	NO	2	NO CALC	NO CALC	NO CALC	NO CALC	NO CALC	NO CALC	NO CALC	NO CALC
14,6	1,0	14,632400000	14,550900000	0,961700000	0,880200000	1	0	0	2	n	50	n	2l	NO	2	NO CALC	NO CALC	NO CALC	NO CALC	NO CALC	NO CALC	NO CALC	NO CALC
14,7	1,0	14,713900000	14,632400000	1,043200000	0,961700000	0	1	0	2	n	50	n	2g	NO	2	NO CALC	NO CALC	NO CALC	NO CALC	NO CALC	NO CALC	NO CALC	NO CALC
14,7	1,1	14,746500000	14,713900000	1,075800000	1,043200000	0	0	0	2	n	20	y	2b	L1	3	14,7473	1,07608	14,746555	1,075803	14,746504	1,0757981	14,7465028	1,0757997
14,8	1,1	14,762800000	14,746500000	1,092100000	1,075800000	1	0	0	3	n	10	n	3k	GL	4	14,7617	1,09204	14,762772	1,092089	14,762789	1,0920948	14,7628030	1,0920988
14,9	1,2	14,876900000	14,762800000	1,206200000	1,092100000	0	1	0	4	n	70	n	4k	NO	2	NO CALC	NO CALC	NO CALC	NO CALC	NO CALC	NO CALC	NO CALC	NO CALC
14,9	1,2	14,893200000	14,876900000	1,222500000	1,206200000	1	0	0	2	n	10	y	2h	GL	4	14,8923	1,22255	14,893205	1,222506	14,893199	1,2224996	14,8931977	1,2225009
15,0	1,3	15,007300000	14,893200000	1,336600000	1,222500000	0	1	0	4	n	70	n	4k	NO	2	NO CALC	NO CALC	NO CALC	NO CALC	NO CALC	NO CALC	NO CALC	NO CALC
15,1	1,4	15,088800000	15,007300000	1,418100000	1,336600000	1	0	0	2	n	50	y	2i	L1	3	15,0882	1,41832	15,088764	1,418084	15,088793	1,4180961	15,0887996	1,4180988

lat sut	lon sut	lat last	lat prev	lon last	lon prev	tl	tp	tr	i	p	tim	o	op	cal	f	decoded lat	decoded lon	decoded 4-bit lat	decoded 4-bit lon	decoded 6-bit lat	decoded 6-bit lon	decoded 8-bit lat	decoded 8-bit lon
15,1	1,5	15,121400000	15,088800000	1,450700000	1,418100000	1	1	0	3	n	20	n	3m	NO	2	NO CALC	NO CALC	NO CALC	NO CALC	NO CALC	NO CALC	NO CALC	NO CALC
15,2	1,5	15,154000000	15,121400000	1,483300000	1,450700000	1	1	0	2	n	20	y	2j	L1	3	15,1535	1,48358	15,154070	1,483292	15,154018	1,4832985	15,1539970	1,4832999
15,2	1,6	15,235500000	15,154000000	1,564800000	1,483300000	0	1	0	3	n	50	n	3g	NO	2	NO CALC	NO CALC	NO CALC	NO CALC	NO CALC	NO CALC	NO CALC	NO CALC
15,3	1,6	15,268100000	15,235500000	1,597400000	1,564800000	0	0	0	2	n	20	y	2b	L1	3	15,2674	1,59764	15,268097	1,597408	15,268108	1,5973991	15,2681011	1,5973997
15,3	1,7	15,349600000	15,268100000	1,678900000	1,597400000	1	0	0	3	n	50	n	3l	NO	2	NO CALC	NO CALC	NO CALC	NO CALC	NO CALC	NO CALC	NO CALC	NO CALC
15,4	1,7	15,365900000	15,349600000	1,695200000	1,678900000	0	1	0	2	n	10	n	2f	GL	4	15,3651	1,69523	15,365952	1,695183	15,365906	1,6951980	15,3658966	1,6951987
15,5	1,8	15,480000000	15,365900000	1,809300000	1,695200000	1	0	0	4	n	70	n	4u	NO	2	NO CALC	NO CALC	NO CALC	NO CALC	NO CALC	NO CALC	NO CALC	NO CALC
15,5	1,8	15,496300000	15,480000000	1,825600000	1,809300000	0	1	0	2	n	10	y	2c	GL	4	15,4969	1,82578	15,496250	1,825596	15,496317	1,8256035	15,4963033	1,8256000
15,6	1,9	15,610400000	15,496300000	1,939700000	1,825600000	1	0	0	4	n	70	y	4p	L1	3	15,6107	1,93970	15,610316	1,939705	15,610391	1,9397047	15,6103982	1,9396994
15,6	2,0	15,626700000	15,610400000	1,956000000	1,939700000	0	1	0	3	n	10	n	3f	GL	4	15,6264	1,95569	15,626722	1,956009	15,626689	1,9559985	15,6267005	1,9559987
15,7	2,1	15,740800000	15,626700000	2,070100000	1,956000000	1	0	0	4	n	70	n	4u	NO	2	NO CALC	NO CALC	NO CALC	NO CALC	NO CALC	NO CALC	NO CALC	NO CALC
15,8	2,1	15,757100000	15,740800000	2,086400000	2,070100000	0	1	0	2	y	10	n	2a	GP	4	15,7582	2,08624	15,757021	2,086422	15,757100	2,0864040	15,7570977	2,0864000
15,9	2,2	15,871200000	15,757100000	2,200500000	2,086400000	1	0	0	4	n	70	y	4p	L1	3	15,8719	2,20073	15,871182	2,200491	15,871211	2,2005036	15,8711974	2,2005011
15,9	2,2	15,887500000	15,871200000	2,216800000	2,200500000	0	1	0	3	y	10	n	3a	GP	4	15,8877	2,21679	15,887493	2,216789	15,887510	2,2167990	15,8875044	2,2167987
15,9	2,2	15,903800000	15,887500000	2,233100000	2,216800000	1	0	0	4	y	10	n	4a	GP	4	15,9046	2,23336	15,903835	2,233119	15,903783	2,2330994	15,9038010	2,2331003
15,9	2,2	15,920100000	15,903800000	2,249400000	2,233100000	0	1	0	4	n	10	n	4i	GL	4	15,9194	2,24910	15,920112	2,249380	15,920084	2,2493951	15,9200965	2,2494010
19,1	5,4	19,098600000	-	5,427900000	-	1	-	-	1	n	-	n	1e	NO	2	NO CALC	NO CALC	NO CALC	NO CALC	NO CALC	NO CALC	NO CALC	NO CALC
19,1	5,4	19,114900000	19,098600000	5,444200000	5,427900000	0	1	0	2	n	10	n	2f	GL	4	19,1160	5,44438	19,114949	5,444196	19,114892	5,4442038	19,1148991	5,4442004
19,1	5,5	19,131200000	19,114900000	5,460500000	5,444200000	1	0	0	4	n	10	n	4q	GL	4	19,1322	5,46021	19,131285	5,460491	19,131210	5,4604954	19,1312031	5,4604990
19,1	5,5	19,147500000	19,131200000	5,476800000	5,460500000	0	1	0	4	n	10	n	4i	GL	4	19,1477	5,47670	19,147567	5,476788	19,147505	5,4768000	19,1475008	5,4768000
19,2	5,5	19,163800000	19,147500000	5,493100000	5,476800000	1	0	1	4	n	10	n	4zb	L2	4	19,1648	5,49281	19,163759	5,493107	19,163782	5,4931006	19,1637968	5,4930992
19,2	5,5	19,180100000	19,163800000	5,509400000	5,493100000	0	1	0	4	n	10	n	4i	GL	4	19,1795	5,50948	19,180185	5,509385	19,180117	5,5094053	19,1801025	5,5093992
23,5	9,8	23,483300000	-	9,812600000	-	1	-	-	1	n	-	y	1d	L1	3	23,4826	9,81276	23,483292	9,812616	23,483304	9,8125971	23,4832965	9,8126010
23,5	9,8	23,499600000	23,483300000	9,828900000	9,812600000	0	1	0	3	n	10	y	3c	GL	4	23,4994	9,82904	23,499564	9,828893	23,499586	9,8288960	23,4996010	9,8288993
23,5	9,8	23,515900000	23,499600000	9,845200000	9,828900000	1	0	0	4	n	10	y	4l	GL	4	23,5152	9,84504	23,515945	9,845185	23,515916	9,8452037	23,5159001	9,8451997
23,5	9,9	23,532200000	23,515900000	9,861500000	9,845200000	0	1	1	4	n	10	y	4v	L2	4	23,5311	9,86152	23,532182	9,861518	23,532199	9,8614959	23,5322027	9,8614991
23,5	9,9	23,548500000	23,532200000	9,877800000	9,861500000	1	0	0	4	n	10	y	4l	GL	4	23,5479	9,87767	23,548419	9,877818	23,548488	9,8778035	23,5485037	9,8778002
27,2	13,5	27,167100000	-	13,496400000	-	0	-	-	1	n	-	y	1b	L1	3	27,1673	13,49615	27,167103	13,496400	27,167120	13,4963982	27,1671041	13,4964006
27,2	13,5	27,183400000	27,167100000	13,512700000	13,496400000	1	0	0	3	n	10	y	3h	GL	4	27,1824	13,51259	27,183315	13,512692	27,183390	13,5127051	27,1833966	13,5126996
27,2	13,5	27,199700000	27,183400000	13,529000000	13,512700000	0	1	0	4	n	10	n	4i	GL	4	27,1990	13,52912	27,199721	13,529017	27,199693	13,5290048	27,1996962	13,5289993
27,2	13,5	27,216000000	27,199700000	13,545300000	13,529000000	1	0	0	4	n	10	n	4q	GL	4	27,2151	13,54520	27,215968	13,545299	27,216002	13,5453002	27,2160002	13,5453006
27,2	13,6	27,232300000	27,216000000	13,561600000	13,545300000	0	1	1	4	n	10	n	4x	L2	4	27,2332	13,56150	27,232339	13,561602	27,232305	13,5616035	27,2322979	13,5616011
27,2	13,6	27,248600000	27,232300000	13,577900000	13,561600000	1	0	0	4	n	10	n	4q	GL	4	27,2477	13,57773	27,248621	13,577890	27,248615	13,5778984	27,2486038	13,5779003
30,4	16,7	30,361900000	-	16,691200000	-	0	-	-	1	n	-	y	1b	L1	3	30,3614	16,69102	30,361940	16,691175	30,361889	16,6911946	30,3618971	16,6911990
30,4	16,7	30,378200000	30,361900000	16,707500000	16,691200000	1	0	0	3	n	10	y	3h	GL	4	30,3774	16,70756	30,378112	16,707510	30,378204	16,7075036	30,3782049	16,7074993
30,4	16,7	30,394500000	30,378200000	16,723800000	16,707500000	0	1	0	4	n	10	y	4d	GL	4	30,3956	16,72363	30,394558	16,723782	30,394502	16,7238012	30,3944988	16,7238000
30,5	16,8	30,508600000	30,394500000	16,837900000	16,723800000	1	0	0	4	n	70	n	4u	NO	2	NO CALC	NO CALC	NO CALC	NO CALC	NO CALC	NO CALC	NO CALC	NO CALC
30,5	16,9	30,524900000	30,508600000	16,854200000	16,837900000	0	1	1	2	n	10	n	2o	NO	2	NO CALC	NO CALC	NO CALC	NO CALC	NO CALC	NO CALC	NO CALC	NO CALC
30,5	16,9	30,541200000	30,524900000	16,870500000	16,854200000	1	0	0	2	n	10	n	2k	GL	4	30,5407	16,87073	30,541198	16,870509	30,541186	16,8705060	30,5412032	16,8704992
30,6	16,9	30,557500000	30,541200000	16,886800000	16,870500000	0	1	0	4	n	10	n	4i	GL	4	30,5568	16,88702	30,557474	16,886808	30,557486	16,8868044	30,5574976	16,8868008
33,4	19,7	33,361100000	-	19,690400000	-	0	-	-	1	y	-	y	1a	GP	4	33,3602	19,69017	33,361068	19,690376	33,361101	19,6904029	33,3610991	19,6904002
33,4	19,7	33,377400000	33,361100000	19,706700000	19,690400000	1	0	0	4	n	10	y	4l	GL	4	33,3765	19,70689	33,377349	19,706725	33,377384	19,7067038	33,3774015	19,7066991
33,4	19,7	33,393700000	33,377400000	19,723000000	19,706700000	0	1	0	4	n	10	y	4d	GL	4	33,3944	19,72313	33,393686	19,723023	33,393714	19,7229977	33,3937008	19,7230007

lat sut	lon sut	lat last	lat prev	lon last	lon prev	tl	tp	tr	i	p	tim	o	op	cal	f	decoded lat	decoded lon	decoded 4-bit lat	decoded 4-bit lon	decoded 6-bit lat	decoded 6-bit lon	decoded 8-bit lat	decoded 8-bit lon	
33,5	19,8	33,507800000	33,393700000	19,837100000	19,723000000	1	0	0	4	n	70	y	4p	L1	3	33,5071	19,83722	33,507782	19,837107	33,507794	19,8371056	33,5077961	19,8370993	
33,5	19,9	33,524100000	33,507800000	19,853400000	19,837100000	0	1	1	3	n	10	y	3n	L1	3	33,5238	19,85313	33,524158	19,853398	33,524085	19,8533967	33,5240979	19,8533993	
33,5	19,9	33,540400000	33,524100000	19,869700000	19,853400000	1	0	0	3	n	10	y	3h	GL	4	33,5397	19,86999	33,540435	19,869707	33,540406	19,8696961	33,5403998	19,8696998	
33,6	19,9	33,556700000	33,540400000	19,886000000	19,869700000	0	1	0	4	n	10	y	4d	GL	4	33,5556	19,88571	33,556777	19,885981	33,556698	19,8860033	33,5566996	19,8859993	
36,1	22,5	36,132100000	-	22,461400000	-	1	-	-	1	y	-	y	1a	GP	4	36,1319	22,46135	36,132048	22,461405	36,132111	22,4613999	36,1320956	22,4613987	
36,1	22,5	36,148400000	36,132100000	22,477700000	22,461400000	0	1	0	4	n	10	y	4d	GL	4	36,1490	22,47788	36,148439	22,477722	36,148411	22,4777006	36,1484045	22,4776990	
36,2	22,5	36,164700000	36,148400000	22,494000000	22,477700000	1	0	0	4	n	10	y	4l	GL	4	36,1645	22,49431	36,164701	22,493974	36,164683	22,4939939	36,1646992	22,4940013	
36,3	22,6	36,278800000	36,164700000	22,608100000	22,494000000	0	1	0	4	n	70	y	4f	L1	3	36,2784	22,60821	36,278737	22,608104	36,278782	22,6081025	36,2788017	22,6080991	
36,3	22,6	36,295100000	36,278800000	22,624400000	22,608100000	1	0	1	3	n	10	n	3q	NO	2	NO CALC	NO CALC	NO CALC	NO CALC	NO CALC	NO CALC	NO CALC	NO CALC	NO CALC
36,3	22,6	36,311400000	36,295100000	22,640700000	22,624400000	0	1	0	2	n	10	n	2f	GL	4	36,3126	22,64107	36,311355	22,640673	36,311395	22,6406981	36,3114034	22,6407006	
36,3	22,7	36,327700000	36,311400000	22,657000000	22,640700000	1	0	0	4	n	10	n	4q	GL	4	36,3278	22,65682	36,327786	22,656993	36,327705	22,6570028	36,3276975	22,6569985	
38,7	25,1	38,723800000	-	25,053100000	-	1	-	-	1	y	-	n	1a	GP	4	38,7240	25,05280	38,723839	25,053089	38,723816	25,0531005	38,7238013	25,0530998	
38,7	25,1	38,740100000	38,723800000	25,069400000	25,053100000	0	1	0	4	n	10	n	4i	GL	4	38,7399	25,06919	38,740101	25,069416	38,740084	25,0693945	38,7400998	25,0693989	
38,8	25,1	38,756400000	38,740100000	25,085700000	25,069400000	1	0	0	4	n	10	n	4q	GL	4	38,7567	25,08535	38,756313	25,085701	38,756388	25,0856940	38,7564049	25,0856988	
38,9	25,2	38,870500000	38,756400000	25,199800000	25,085700000	0	1	0	4	n	70	n	4k	NO	2	NO CALC	NO CALC	NO CALC	NO CALC	NO CALC	NO CALC	NO CALC	NO CALC	NO CALC
38,9	25,2	38,886800000	38,870500000	25,216100000	25,199800000	1	0	1	2	n	10	y	2p	L1	3	38,8873	25,21601	38,886746	25,216128	38,886798	25,2161026	38,8867996	25,2161004	
38,9	25,2	38,903100000	38,886800000	25,232400000	25,216100000	0	1	0	3	n	10	y	3c	GL	4	38,9035	25,23266	38,903018	25,232427	38,903108	25,2323973	38,9030987	25,2324003	
38,9	25,2	38,919400000	38,903100000	25,248700000	25,232400000	1	0	0	4	n	10	y	4l	GL	4	38,9199	25,24897	38,919399	25,248727	38,919411	25,2486956	38,9194032	25,2486987	
41,2	27,5	41,185100000	-	27,514400000	-	0	-	-	1	n	-	y	1b	L1	3	41,1844	27,51470	41,185069	27,514410	41,185120	27,5143983	41,1851019	27,5143990	
41,2	27,5	41,201400000	41,185100000	27,530700000	27,514400000	1	0	0	3	n	10	y	3h	GL	4	41,2006	27,53088	41,201346	27,530702	41,201398	27,5307061	41,2013993	27,5307003	
41,2	27,5	41,217700000	41,201400000	27,547000000	27,530700000	0	1	0	4	n	10	y	4d	GL	4	41,2186	27,54725	41,217687	27,547022	41,217693	27,5470049	41,2177036	27,5470011	
41,3	27,7	41,331800000	41,217700000	27,661100000	27,547000000	1	0	0	4	n	70	y	4p	L1	3	41,3312	27,66104	41,331778	27,661097	41,331807	27,6611052	41,3318039	27,6611002	
41,3	27,7	41,348100000	41,331800000	27,677400000	27,661100000	0	1	1	3	n	10	n	3o	NO	2	NO CALC	NO CALC	NO CALC	NO CALC	NO CALC	NO CALC	NO CALC	NO CALC	NO CALC
41,4	27,7	41,364400000	41,348100000	27,693700000	27,677400000	1	0	0	2	n	10	n	2k	GL	4	41,3639	27,69339	41,364431	27,693703	41,364420	27,6937014	41,3643976	27,6937009	
41,4	27,7	41,380700000	41,364400000	27,710000000	27,693700000	0	1	0	4	n	10	n	4i	GL	4	41,3797	27,71006	41,380778	27,709996	41,380716	27,7100014	41,3807024	27,7099994	
43,5	29,9	43,532300000	-	29,861600000	-	0	-	-	1	y	-	y	1a	GP	4	43,5311	29,86182	43,532357	29,861576	43,532317	29,8615993	43,5322988	29,8616011	
43,5	29,9	43,548600000	43,532300000	29,877900000	29,861600000	1	0	0	4	n	10	y	4l	GL	4	43,5491	29,87760	43,548598	29,877919	43,548610	29,8779025	43,5486026	29,8778990	
43,6	29,9	43,564900000	43,548600000	29,894200000	29,877900000	0	1	0	4	n	10	y	4d	GL	4	43,5653	29,89393	43,564975	29,894175	43,564890	29,8942058	43,5649005	29,8941994	
43,7	30,0	43,679000000	43,564900000	30,008300000	29,894200000	1	0	0	4	n	70	n	4u	NO	2	NO CALC	NO CALC	NO CALC	NO CALC	NO CALC	NO CALC	NO CALC	NO CALC	NO CALC
43,7	30,0	43,695300000	43,679000000	30,024600000	30,008300000	0	1	1	2	n	10	y	2n	L1	3	43,6947	30,02439	43,695273	30,024579	43,695301	30,0246038	43,6952977	30,0245988	
43,7	30,0	43,711600000	43,695300000	30,040900000	30,024600000	1	0	0	3	n	10	y	3h	GL	4	43,7124	30,04120	43,711684	30,040874	43,711592	30,0409059	43,7116009	30,0408985	
43,7	30,1	43,727900000	43,711600000	30,057200000	30,040900000	0	1	0	4	n	10	y	4d	GL	4	43,7289	30,05691	43,727891	30,057227	43,727914	30,0571962	43,7278994	30,0571999	
45,8	32,1	45,781700000	-	32,111000000	-	1	-	-	1	y	-	y	1a	GP	4	45,7821	32,11133	45,781745	32,111008	45,781698	32,1109953	45,7816982	32,1109997	
45,8	32,1	45,798000000	45,781700000	32,127300000	32,111000000	0	1	0	4	n	10	y	4d	GL	4	45,7973	32,12686	45,798012	32,127303	45,797983	32,1273027	45,7979964	32,1272992	
45,8	32,1	45,814300000	45,798000000	32,143600000	32,127300000	1	0	0	4	n	10	y	4l	GL	4	45,8148	32,14338	45,814218	32,143577	45,814311	32,1436018	45,8143018	32,1436002	
45,9	32,3	45,928400000	45,814300000	32,257700000	32,143600000	0	1	0	4	n	70	n	4k	NO	2	NO CALC	NO CALC	NO CALC	NO CALC	NO CALC	NO CALC	NO CALC	NO CALC	NO CALC
45,9	32,3	45,944700000	45,928400000	32,274000000	32,257700000	1	0	1	2	n	10	n	2q	NO	2	NO CALC	NO CALC	NO CALC	NO CALC	NO CALC	NO CALC	NO CALC	NO CALC	NO CALC
46,0	32,3	45,961000000	45,944700000	32,290300000	32,274000000	0	1	0	2	n	10	n	2f	GL	4	45,9609	32,28987	45,960928	32,290331	45,961007	32,2903019	45,9609953	32,2902990	
46,0	32,3	45,977300000	45,961000000	32,306600000	32,290300000	1	0	0	4	n	10	n	4q	GL	4	45,9780	32,30655	45,977304	32,306621	45,977293	32,3065994	45,9773001	32,3065983	

lat sut	lon sut	lat last	lat prev	lon last	lon prev	tl	tp	tr	i	p	tim	o	op	cal	f	decoded lat	decoded lon	decoded 4-bit lat	decoded 4-bit lon	decoded 6-bit lat	decoded 6-bit lon	decoded 8-bit lat	decoded 8-bit lon
47,9	34,3	47,949600000	-	34,278900000	-	1	-	-	1	y	-	n	1a	GP	4	47,9498	34,27848	47,949585	34,278890	47,949602	34,2788967	47,9495964	34,2788981
48,0	34,3	47,965900000	47,949600000	34,295200000	34,278900000	0	1	0	4	n	10	n	4i	GL	4	47,9658	34,29500	47,965986	34,295197	47,965891	34,2951929	47,9658985	34,2951992
48,0	34,3	47,982200000	47,965900000	34,311500000	34,295200000	1	0	0	4	n	10	n	4q	GL	4	47,9824	34,31192	47,982238	34,311510	47,982215	34,3115032	47,9822000	34,3115018
48,1	34,4	48,096300000	47,982200000	34,425600000	34,311500000	0	1	0	4	n	70	y	4f	L1	3	48,0952	34,42593	48,096285	34,425602	48,096302	34,4256044	48,0962957	34,4256013
48,1	34,4	48,112600000	48,096300000	34,441900000	34,425600000	1	0	1	3	n	10	y	3p	L1	3	48,1130	34,44224	48,112671	34,441887	48,112584	34,4419050	48,1126046	34,4419012
48,1	34,5	48,128900000	48,112600000	34,458200000	34,441900000	0	1	0	3	n	10	y	3c	GL	4	48,1294	34,45809	48,128903	34,458231	48,128914	34,4582020	48,1288973	34,4581995
48,1	34,5	48,145200000	48,128900000	34,474500000	34,458200000	1	0	0	4	n	10	y	4l	GL	4	48,1457	34,47421	48,145145	34,474491	48,145197	34,4744955	48,1451983	34,4745005

7.4.3.1.4 Tables of values for use in content checking test cases

Table 7.9: Values for use in the test "ADSB_DOS_A"

	ADSB_DOS_APPIN_PARAMETERS(x)				ADSB_DOS_RF_OUT_PARAMETERS(x)			
	Set P (middle range)	Set Q (min)	Set R (max)	Set S (zero)	Set P (middle range)	Set Q (min)	Set R (max)	Set S (zero)
s	add_A	add_A	add_A	add_A	add_A	add_A	add_A	add_A
Entry number (ent)	1 DOS message	1 DOS message	1 DOS message	1 DOS message	1	1	1	1
Additional service information (ai) Bit 1	si field included	si field not included	si field included	si field not included	1	0	1	0
Additional service information (ai) Bit 2	anum field included	anum field not included	anum field included	anum field not included	1	0	1	0
Additional service information (ai) Bit 3	application (a) subfield not present	application (a) subfield present	application (a) subfield not present	application (a) subfield present	0	1	0	1
GSC flag (gsc)	Channel is a GSC	Channel is a GSC	Channel is a GSC	Channel is a GSC	1	1	1	1
Service information (si)		NOT TRANSMITTED		NOT TRANSMITTED				
Application number (anum)	Zero application fields present	NOT TRANSMITTED	Zero application fields present	NOT TRANSMITTED	0		0	

Table 7.10: Values for use in the test "ADSB_Channel_A"

	ADSB_CHANNEL_APPIN_PARAMETERS(x)				ADSB_CHANNEL_RF_OUT_PARAMETERS(x)			
	Set P (middle range)	Set Q (min)	Set R (max)	Set S (zero)	Set P (middle range)	Set Q (min)	Set R (max)	Set S (zero)
s	add_A	add_A	add_A	add_A	add_A	add_A	add_A	add_A
Directed timeout (dt)	5 planned future transmissions reserved in slots spaced M1 slots apart	1 planned future transmissions reserved in slots spaced M1 slots apart	14 planned future transmissions reserved in slots spaced M1 slots apart	0 planned future transmissions reserved in slots spaced M1 slots apart	5	1	14	0
Directed offset (do)	Directed a slot reservation, transmit in slot 100	Directed a slot reservation, transmit in slot 2	Directed a slot reservation, transmit in slot 4 095	Directed rate reservation	100	2	4 095	0
Destination Count (dc)	1 octet in destination block	1 octet in destination block	1 octet in destination block	Destination block absent: Channel management message applies to all stations (i.e. broadcast)	1	1	1	0
Command set ID (csid)	1 command per aircraft	1 command per aircraft	1 command per aircraft	cancel all previous commands	0	0	0	15
transmission definition count (tc)	1 element in transmission definition block	1 element in transmission definition block	1 element in transmission definition block	1 element in transmission definition block	1	1	1	1
frequency count (fc)	1 element in the frequency block	1 element in the frequency block	1 element in the frequency block	1 element in the frequency block	1	1	1	1
script duration type (styp)	Interpret script rate (sr) as the number of times the entire script repeats per minute.	Interpret script rate (sr) as the number of minutes until script repeats	Interpret script rate (sr) as the number of times the entire script repeats per minute.	Interpret script rate (sr) as the number of minutes until script repeats	0	1	0	1
script rate (sr)	8 transmissions per minute	2 minutes between a transmission	60 transmissions per minute	15 minutes between a transmission	6	0	13	13
transmit parameter count (ps)	1 octet in the transmit parameter block	1 octet in the transmit parameter block	1 octet in the transmit parameter block	1 octet in the transmit parameter block	1	1	1	1
script count (sc)	1 octet in script block	1 octet in script block	1 octet in script block	1 octet in script block	0	0	0	0
ido	0 individual offset	1 individual offset	2 individual offset	1 individual offset	0	1	2	1
d	0000 10 101 010 00 00 0000 0001	0000 10 101 010 00 00 0000 0010	0000 10 101 010 00 00 0000 0011	0000 10 101 010 00 00 0000 0010	0000 10 101 010 00 00 0000 0001	0000 10 101 010 00 00 0000 0010	0000 10 101 010 00 00 0000 0011	0000 10 101 010 00 00 0000 0010
destination address (d) bit 25	Aircraft	Aircraft	Mobile	Aircraft	0	0	0	0
destination address (d) bit 26					0	0	0	

ADSB_CHANNEL_APPIN_PARAMETERS(x)					ADSB_CHANNEL_RF_OUT_PARAMETERS(x)			
	Set P (middle range)	Set Q (min)	Set R (max)	Set S (zero)	Set P (middle range)	Set Q (min)	Set R (max)	Set S (zero)
destination address (d) bit 27					1	1	0	
sleep	No sleep mode	No sleep mode	No sleep mode	No sleep mode	0	0	0	0
auto	Autonomously select transmitted information field	Autonomously select transmitted information field	Autonomously select transmitted information field	Autonomously select transmitted information field	0	0	0	0
Must receive (rcv)	Reception on this specific frequency is mandatory	Reception on this specific frequency is mandatory	Reception on this specific frequency is mandatory	Reception on this specific frequency is optional	1	1	1	0
Frequency (f)	108 MHz	108,025 MHz	135,075 MHz	128,025 MHz	1	2	1 083	801
Frequency (f) bit 12	VHF band 108 MHz to 136,975 MHz	VHF band 108 MHz to 136,975 MHz	VHF band 108 MHz to 136,975 MHz	VHF band 108 MHz to 136,975 MHz	0	0	0	0
Slot selection range constraint for level 1 (Q2a)	150	0	1 000	0	150	0	1 000	0
Slot selection range constraint for level 2 (Q2b)	150	0	1 000	0	150	0	1 000	0
Slot selection range constraint for level 3 (Q2c)	0	0	1 000	0	0	0	1 000	0
Slot selection range constraint for level 4 (Q2d)	300	0	1 000	0	300	0	1 000	0
Priority (Q1)	11	0	15	0	11	0	15	0
No of available slots (Q4)	3	1	20	1	3	1	20	1
Reservation hold timer minimum value (TV11min)	4	0	15	0	4	0	15	0
Reservation hold timer minimum value (TV11max)	8	1	16	1	8	1	16	1
Number of ground quarantined slots (V11)	4	0	15	0	0	4	15	0
Minimum CCI performance (VS2)	12	60	12	12	0	0	48	0
Quarantine slot reuse range (VS4)	300	0	1 000	0	30	0	100	0

ADSB_CHANNEL_APPIN_PARAMETERS(x)					ADSB_CHANNEL_RF_OUT_PARAMETERS(x)			
	Set P (middle range)	Set Q (min)	Set R (max)	Set S (zero)	Set P (middle range)	Set Q (min)	Set R (max)	Set S (zero)
Frequency index (frq)	First element in frequency block	First element in frequency block	First element in frequency block	First element in frequency block	0	0	0	0
Transmission definition index (txd)	Sync burst with baro altitude, no sleep parameters, basic variable field baro alt rate	Sync burst with geo altitude, no sleep parameters, basic variable field geo alt rate	Sync burst with baro altitude, no sleep parameters, basic variable field baro alt rate	Sync burst with geo altitude, no sleep parameters, basic variable field geo alt rate	0	1	0	1
nsd	txd indicates offset from beginning of transmission definition list	txd indicates offset from beginning of transmission definition list	txd indicates offset from beginning of transmission definition list	txd indicates offset from beginning of transmission definition list	1	1	1	1

Table 7.11: Values for use in the test "ADSB_Channel_D"

ADSB_CHANNEL_D_APPIN_PARAMETERS(x)					ADSB_CHANNEL_D_RF_OUT_PARAMETERS(x)			
	Set P (middle range)	Set Q (min)	Set R (max)	Set S (zero)	Set P (middle range)	Set Q (min)	Set R (max)	Set S (zero)
s	add_A	add_A	add_A	add_A	add_A	add_A	add_A	add_A
Directed timeout (dt)	5 planned future transmissions reserved in slots spaced M1 slots apart	1 planned future transmissions reserved in slots spaced M1 slots apart	14 planned future transmissions reserved in slots spaced M1 slots apart	0 planned future transmissions reserved in slots spaced M1 slots apart	5	1	14	0
Directed offset (do)	Directed a slot reservation, transmit in slot 100	Directed a slot reservation, transmit in slot 2	Directed a slot reservation, transmit in slot 4 095	Directed rate reservation	100	2	4 095	0
Destination Count (dc)	Destination block absent: Channel management message applies to all stations (i.e. broadcast)	Destination block absent: Channel management message applies to all stations (i.e. broadcast)	Destination block absent: Channel management message applies to all stations (i.e. broadcast)	Destination block absent: Channel management message applies to all stations (i.e. broadcast)	0	0	0	0
Command set ID (csid)	1 command per aircraft	1 command per aircraft	1 command per aircraft	cancel all previous commands	0	0	0	15
transmission definition count (tc)	transmission block absent	transmission block absent	transmission block absent	transmission block absent	0	0	0	0
frequency count (fc)	1 element in the frequency block	1 element in the frequency block	1 element in the frequency block	No frequency listed	1	1	1	0

ADSB_CHANNEL_D_APPIN_PARAMETERS(x)					ADSB_CHANNEL_D_RF_OUT_PARAMETERS(x)			
	Set P (middle range)	Set Q (min)	Set R (max)	Set S (zero)	Set P (middle range)	Set Q (min)	Set R (max)	Set S (zero)
script duration type (styp)	Interpret script rate (sr) as the number of times the entire script repeats per minute.	Interpret script rate (sr) as the number of minutes until script repeats	Interpret script rate (sr) as the number of times the entire script repeats per minute.	Interpret script rate (sr) as the number of minutes until script repeats	0	1	0	1
script rate (sr)	8 transmissions per minute	2 minutes between a transmission	60 transmissions per minute	15 minutes between a transmission	6	0	13	13
transmit parameter count (ps)	1 octet in the transmit parameter block	1 octet in the transmit parameter block	1 octet in the transmit parameter block	1 octet in the transmit parameter block	1	1	1	1
script count (sc)	1 octet in script block	1 octet in script block	1 octet in script block	1 octet in script block	0	0	0	0
vertex count (vc)	2 vertices	2 vertices	2 vertices	2 vertices	1	1	1	1
centre latitude (lat, lat4)	As encoded in test CPR_Encode	As encoded in test CPR_Encode	As encoded in test CPR_Encode	As encoded in test CPR_Encode				
centre longitude (lon,lon4)	As encoded in test CPR_Encode	As encoded in test CPR_Encode	As encoded in test CPR_Encode	As encoded in test CPR_Encode				
lower altitude (lalt)	-1 500 ft	-1 500 ft	1 000 feet	0 feet	0	0	10	6
upper altitude (ualt)	50 000 ft	1 000 ft	no upper limit	1 000 ft	206	10	255	10
vertex 1 radial 1 (r1)	10 degrees clockwise from north	20 degrees clockwise from north	30 degrees clockwise from north	40 degrees clockwise from north	7	14	21	28
vertex 1 distance 1 (d1)	< 60 NM	< 0,5 NM	< 660 NM	< 62 NM	90	0	255	91
vertex 2 radial 2 (r2)	20 degrees clockwise from north	30 degrees clockwise from north	40 degrees clockwise from north	50 degrees clockwise from north	14	21	28	35
vertex 2 distance 2 (d2)	< 60 NM	< 0,5 NM	< 660 NM	< 62 NM	90	0	255	91
sleep	No sleep mode	No sleep mode	No sleep mode	No sleep mode	0	0	0	0
auto	Autonomously select transmitted information field	Autonomously select transmitted information field	Autonomously select transmitted information field	Autonomously select transmitted information field	0	0	0	0
Must receive (rcv)	Reception on this specific frequency is mandatory	Reception on this specific frequency is mandatory	Reception on this specific frequency is mandatory	Reception on this specific frequency is optional	1	1	1	0
Frequency (f)	108 MHz	108,025 MHz	135,075 MHz	128,025 MHz	1	2	1 083	801
Frequency (f) bit 12	VHF band 108 - 136,975 MHz	VHF band 108 to 136,975 MHz	VHF band 108 to 136,975 MHz	VHF band 108 to 136,975 MHz	0	0	0	0
Slot selection range constraint for level 1 (Q2a)	150	0	1 000	0	150	0	1 000	0
Slot selection range constraint for level 2 (Q2b)	150	0	1 000	0	150	0	1 000	0

	ADSB_CHANNEL_D_APPIN_PARAMETERS(x)				ADSB_CHANNEL_D_RF_OUT_PARAMETERS(x)			
	Set P (middle range)	Set Q (min)	Set R (max)	Set S (zero)	Set P (middle range)	Set Q (min)	Set R (max)	Set S (zero)
Slot selection range constraint for level 3 (Q2c)	0	0	1 000	0	0	0	1 000	0
Slot selection range constraint for level 4 (Q2d)	300	0	1 000	0	300	0	1 000	0
Priority (Q1)	11	0	15	0	11	0	15	0
No of available slots (Q4)	3	1	20	1	3	1	20	1
Reservation hold timer minimum value (TV11min)	4	0	15	0	4	0	15	0
Reservation hold timer minimum value (TV11max)	8	1	16	1	8	1	16	1
Number of ground quarantined slots (V11)	4	0	15	0	0	4	15	0
Minimum CCI performance (VS2)	12	60	12	12	0	0	48	0
Quarantine slot reuse range (VS4)	300	0	1 000	0	30	0	100	0
Frequency index (frq)	First element in frequency block	First element in frequency block	First element in frequency block	First element in frequency block	0	0	0	0
Transmission definition index (txd)	Sync burst with baro altitude, no sleep parameters, basic variable field baro alt rate	Sync burst with geo altitude, no sleep parameters, basic variable field geo alt rate	Sync burst with baro altitude, no sleep parameters, basic variable field baro alt rate	Sync burst with geo altitude, no sleep parameters, basic variable field geo alt rate	0	1	0	1
nsd	txd encoded as defined in table 3.34	txd encoded as defined in table 3.34	txd encoded as defined in table 3.34	txd encoded as defined in table 3.34	0	0	0	0

Table 7.12: Values for use in the test "ADSB_Basic_Ground_A"

ADSB_BASIC_GROUND_APPIN_PARAMETERS(x)					ADSB_BASIC_GROUND_RF_OUT_PARAMETERS(x)			
	Set P (middle range)	Set Q (min)	Set R (max)	Set S (zero)	Set P (middle range)	Set Q (min)	Set R (max)	Set S (zero)
s	add_A	add_A	add_A	add_A	add_A	add_A	add_A	add_A
h	5am	1am	11pm	midnight	5	1	23	0
min	27 minutes	1 minute	59 minutes	0 minutes	27	1	59	0
pid	As encoded in test CPR_Encode	As encoded in test CPR_Encode	As encoded in test CPR_Encode	As encoded in test CPR_Encode	As encoded in test CPR_Encode	As encoded in test CPR_Encode	As encoded in test CPR_Encode	As encoded in test CPR_Encode
bgo	4 000 ft	-2 000 ft	-5 000 ft	7 200 ft	123	3	2	124
slt	slot 50	slot 2	slot 256	first slot in s frame	49	1	255	0
lat4	As encoded in test CPR_Encode	As encoded in test CPR_Encode	As encoded in test CPR_Encode	As encoded in test CPR_Encode	As encoded in test CPR_Encode	As encoded in test CPR_Encode	As encoded in test CPR_Encode	As encoded in test CPR_Encode
lon4	As encoded in test CPR_Encode	As encoded in test CPR_Encode	As encoded in test CPR_Encode	As encoded in test CPR_Encode	As encoded in test CPR_Encode	As encoded in test CPR_Encode	As encoded in test CPR_Encode	As encoded in test CPR_Encode
Assumed altitude to calculate baro/geo offset (bgo) from (ft)	20 000 feet	20 000 feet	30 000 feet	30 000 feet	N/A	N/A	N/A	N/A

Table 7.13: Values for use in the test "ADSB.UTC_Time_A"

ADSB.UTC_TIME_APPIN_PARAMETERS(x)					ADSB.UTC_TIME_RF_OUT_PARAMETERS(x)			
	Set P (middle range)	Set Q (min)	Set R (max)	Set S (zero)	Set P (middle range)	Set Q (min)	Set R (max)	Set S (zero)
s	add_A	add_A	add_A	add_A	add_A	add_A	add_A	add_A
day	day 6	day 1	day 31	day 1	6	1	31	1
year	2 003	2 004	2 003	2 005	33	34	33	35
h	5am	1am	11pm	midnight	5	1	23	0
min	27 minutes	1 minute	59 minutes	0 minutes	27	1	59	0
slt	slot 50	slot 2	slot 256	first slot in s frame	49	1	255	0
lat4	As encoded in test CPR_Encode	As encoded in test CPR_Encode	As encoded in test CPR_Encode	As encoded in test CPR_Encode	As encoded in test CPR_Encode	As encoded in test CPR_Encode	As encoded in test CPR_Encode	As encoded in test CPR_Encode
lon4	As encoded in test CPR_Encode	As encoded in test CPR_Encode	As encoded in test CPR_Encode	As encoded in test CPR_Encode	As encoded in test CPR_Encode	As encoded in test CPR_Encode	As encoded in test CPR_Encode	As encoded in test CPR_Encode
sec	25 s	0 s	60 s	0 s	25 s	0 s	60 s	0 s

Table 7.14: Values for use in the test "ADSB_Basic_Rec_A"

ADSB_BASIC_RF_IN_PARAMETERS(x)					ADSB_BASIC_APOUT_PARAMETERS(x)			
	Set P (middle range)	Set Q (min)	Set R (max)	Set S (zero)	Set P (middle range)	Set Q (min)	Set R (max)	Set S (zero)
s	add_B	add_B	add_B	add_B	add_B	add_B	add_B	add_B
sil	0	1	2	3	Probability of exceeding the R _C integrity containment radius without detection: unknown	Probability of exceeding the R _C integrity containment radius without detection: 1 × 10 ⁻³ per flight hour or per operation	Probability of exceeding the R _C integrity containment radius without detection: 1 × 10 ⁻⁵ per flight hour or per operation	Probability of exceeding the R _C integrity containment radius without detection: 1 × 10 ⁻⁷ per flight hour or per operation
lat6	As encoded in test CPR_Decode	As encoded in test CPR_Decode	As encoded in test CPR_Decode	As encoded in test CPR_Decode	As encoded in test CPR_Decode	As encoded in test CPR_Decode	As encoded in test CPR_Decode	As encoded in test CPR_Decode
br/gr	0	0	0	1	Barometric altitude rate	Barometric altitude rate	Barometric altitude rate	Geometric altitude rate
lon6	As encoded in test CPR_Decode	As encoded in test CPR_Decode	As encoded in test CPR_Decode	As encoded in test CPR_Decode	As encoded in test CPR_Decode	As encoded in test CPR_Decode	As encoded in test CPR_Decode	As encoded in test CPR_Decode
altr bit 9	0	0	1	1	Climbing	Climbing	Descending	Descending
altr bits 1 - 8	201	1	255	0	20 000 fpm	0 fpm	32 000 fpm	Unknown
bgo	123	3	2	124	4 000 ft	-2 000 ft	-5 000 ft	7 200 ft
gs	1 023	1	2 047	0	1 022	0	3 069	unknown
gt	290	0	2 042	0	51 degrees	0 degree (north)	359 degrees	0 degree (north)
Assumed altitude to calculate baro/geo offset (bgo) from (ft)	N/A	N/A	N/A	N/A	20 000 feet	20 000 feet	30 000 feet	30 000 feet

Table 7.15: Values for use in the test "ADSB_High_Dynamic_Rec_A"

ADSB_HIGH_DYNAMIC_RF_IN_PARAMETERS(x)					ADSB_HIGH_DYNAMIC_APPOUT_PARAMETERS(x)			
	Set P (middle range)	Set Q (min)	Set R (max)	Set S (zero)	Set P (middle range)	Set Q (min)	Set R (max)	Set S (zero)
s	add_B	add_B	add_B	add_B	add_B	add_B	add_B	add_B
lat4	As encoded in test CPR_Encode	As encoded in test CPR_Encode	As encoded in test CPR_Encode	As encoded in test CPR_Encode	As encoded in test CPR_Encode	As encoded in test CPR_Encode	As encoded in test CPR_Encode	As encoded in test CPR_Encode
br/gr	0	0	0	1	Barometric altitude rate	Barometric altitude rate	Barometric altitude rate	Geometric altitude rate
lon4	As encoded in test CPR_Encode	As encoded in test CPR_Encode	As encoded in test CPR_Encode	As encoded in test CPR_Encode	As encoded in test CPR_Encode	As encoded in test CPR_Encode	As encoded in test CPR_Encode	As encoded in test CPR_Encode
altr bit 9	0	0	1	1	Climbing	Climbing	Descending	Descending
altr bits 1 - 8	201	1	255	0	20 000 fpm	0 fpm	32 000 fpm	Unknown
sil	0	1	2	3	Probability of exceeding the R _C integrity containment radius without detection: unknown	Probability of exceeding the R _C integrity containment radius without detection: 1 × 10 ⁻³ per flight hour or per operation	Probability of exceeding the R _C integrity containment radius without detection: 1 × 10 ⁻⁵ per flight hour or per operation	Probability of exceeding the R _C integrity containment radius without detection: 1 × 10 ⁻⁷ per flight hour or per operation
bgo	123	3	2	124	4 000 ft	-2 000 ft	-5 000 ft	7 200 ft
gs	1 023	1	2 047	0	1 022	0	3 069	unknown
gt	580	0	4 085	0	51 degrees	0 degree (north)	359 degrees	0 degree (north)
Assumed altitude to calculate baro/geo offset (bgo) from (ft)	N/A	N/A	N/A	N/A	20 000 feet	20 000 feet	30 000 feet	30 000 feet

Table 7.16: Values for use in the test "ADSB_Full_Position_Rec_A"

ADSB_FULL_POSITION_RF_IN_PARAMETERS(x)					ADSB_FULL_POSITION_APOUT_PARAMETERS(x)			
	Set P (middle range)	Set Q (min)	Set R (max)	Set S (zero)	Set P (middle range)	Set Q (min)	Set R (max)	Set S (zero)
s	add_B	add_B	add_B	add_B	add_B	add_B	add_B	add_B
lat6	As decoded in test CPR_Decode	As decoded in test CPR_Decode	As decoded in test CPR_Decode	As decoded in test CPR_Decode	As decoded in test CPR_Decode	As decoded in test CPR_Decode	As decoded in test CPR_Decode	As decoded in test CPR_Decode
pid	As decoded in test CPR_Decode	As decoded in test CPR_Decode	As decoded in test CPR_Decode	As decoded in test CPR_Decode	As decoded in test CPR_Decode	As decoded in test CPR_Decode	As decoded in test CPR_Decode	As decoded in test CPR_Decode
lon6	As decoded in test CPR_Decode	As decoded in test CPR_Decode	As decoded in test CPR_Decode	As decoded in test CPR_Decode	As decoded in test CPR_Decode	As decoded in test CPR_Decode	As decoded in test CPR_Decode	As decoded in test CPR_Decode
bgo	123	3	2	124	4 000 ft	-2 000 ft	-5 000 ft	7 200 ft
sil	0	1	2	3	Probability of exceeding the R_c integrity containment radius without detection: unknown	Probability of exceeding the R_c integrity containment radius without detection: 1×10^{-3} per flight hour or per operation	Probability of exceeding the R_c integrity containment radius without detection: 1×10^{-5} per flight hour or per operation	Probability of exceeding the R_c integrity containment radius without detection: 1×10^{-7} per flight hour or per operation
gs	1 023	1	2 047	0	1 022	0	3 069	unknown
gt	290	0	2 042	0	51 degrees	0 degree (north)	359 degrees	0 degree (north)
Assumed altitude to calculate baro/geo offset (bgo) from (ft)	N/A	N/A	N/A	N/A	20 000 feet	20 000 feet	30 000 feet	30 000 feet

Table 7.17: Values for use in the test "ADSB_Two_Slot_TCP/SVQ_Rec_A"

ADSB_TWO_SLOT_TCP/SVQ_RF_IN_PARAMETERS(x)					ADSB_TWO_SLOT_TCP/SVQ_APOUT_PARAMETERS(x)			
	Set P (middle range)	Set Q (min)	Set R (max)	Set S (zero)	Set P (middle range)	Set Q (min)	Set R (max)	Set S (zero)
s	add_B	add_B	add_B	add_B	add_B	add_B	add_B	add_B
lat	As encoded in test CPR_Encode	As encoded in test CPR_Encode	As encoded in test CPR_Encode	As encoded in test CPR_Encode	As encoded in test CPR_Encode	As encoded in test CPR_Encode	As encoded in test CPR_Encode	As encoded in test CPR_Encode
balt	936	2	4 072	132	8 025 feet	-1 300 feet	130 000 feet	0 feet
lon	As encoded in test CPR_Encode	As encoded in test CPR_Encode	As encoded in test CPR_Encode	As encoded in test CPR_Encode	As encoded in test CPR_Encode	As encoded in test CPR_Encode	As encoded in test CPR_Encode	As encoded in test CPR_Encode
ttg	3	0	62	0	0,5 minutes	0 minute	15,25 minutes	0 minute
lat	As encoded in test CPR_Encode	As encoded in test CPR_Encode	As encoded in test CPR_Encode	As encoded in test CPR_Encode	As encoded in test CPR_Encode	As encoded in test CPR_Encode	As encoded in test CPR_Encode	As encoded in test CPR_Encode
balt	936	2	4 072	132	8 025 feet	-1 300 feet	130 000 feet	0 feet
lon	As encoded in test CPR_Encode	As encoded in test CPR_Encode	As encoded in test CPR_Encode	As encoded in test CPR_Encode	As encoded in test CPR_Encode	As encoded in test CPR_Encode	As encoded in test CPR_Encode	As encoded in test CPR_Encode
ttg	4	0	62	0	0,75 minutes	0 minute	15,25 minutes	0 minute
lat	As encoded in test CPR_Encode	As encoded in test CPR_Encode	As encoded in test CPR_Encode	As encoded in test CPR_Encode	As encoded in test CPR_Encode	As encoded in test CPR_Encode	As encoded in test CPR_Encode	As encoded in test CPR_Encode
balt	936	2	4 072	132	8 025 feet	-1 300 feet	130 000 feet	0 feet
lon	As encoded in test CPR_Encode	As encoded in test CPR_Encode	As encoded in test CPR_Encode	As encoded in test CPR_Encode	As encoded in test CPR_Encode	As encoded in test CPR_Encode	As encoded in test CPR_Encode	As encoded in test CPR_Encode
ttg	5	0	62	0	1 minutes	0 minute	15,25 minutes	0 minute
lat	As encoded in test CPR_Encode	As encoded in test CPR_Encode	As encoded in test CPR_Encode	As encoded in test CPR_Encode	As encoded in test CPR_Encode	As encoded in test CPR_Encode	As encoded in test CPR_Encode	As encoded in test CPR_Encode
balt	936	2	4 072	132	8 025 feet	-1 300 feet	130 000 feet	0 feet
lon	As encoded in test CPR_Encode	As encoded in test CPR_Encode	As encoded in test CPR_Encode	As encoded in test CPR_Encode	As encoded in test CPR_Encode	As encoded in test CPR_Encode	As encoded in test CPR_Encode	As encoded in test CPR_Encode
ttg	6	0	62	0	1,25 minutes	0 minute	15,25 minutes	0 minute

ADSB_TWO_SLOT_TCP/SVQ_RF_IN_PARAMETERS(x)					ADSB_TWO_SLOT_TCP/SVQ_APOUT_PARAMETERS(x)			
	Set P (middle range)	Set Q (min)	Set R (max)	Set S (zero)	Set P (middle range)	Set Q (min)	Set R (max)	Set S (zero)
csi	00 00 00 00	01 01 01 01	02 02 02 02	03 03 03 03	AAAA	BBBB	CCCC	DDDD
st	0	1	4	5	no emergency/not reported	general emergency	no communications	unlawful interference
csr	26 26 26 26	27 27 27 27	28 28 28 28	29 29 29 29	0000	1111	2222	3333
nacv	1	2	3	4	Horizontal velocity error (95 %) < 10 m/s	Horizontal velocity error (95 %) < 3 m/s	Horizontal velocity error (95 %) < 1 m/s	Horizontal velocity error (95 %) < 0,3 m/s
nacp	2	0	6	11	EPU < 7,408 Km (4NM)	EPU ≥ 18,52 Km (10NM)	EPU < 555,6 m (0,3 NM)	EPU < 3 m and VEPU < 4 m
cdti	1	1	0	0	CDTI equipment installed and operational	CDTI equipment installed and operational	not CDTI equipped	not CDTI equipped
nicb	1	0	1	0.	Barometric pressure altitude has been cross checked against another source of pressure altitude	Barometric pressure altitude has not been cross checked against another source of pressure altitude	Barometric pressure altitude has been cross checked against another source of pressure altitude	Barometric pressure altitude has not been cross checked against another source of pressure altitude
acas	1	1	1	1	ACAS installed and operational	ACAS installed and operational	ACAS installed and operational	ACAS installed and operational
ra	1	1	1	0	Resolution activity active	Resolution activity not active	Resolution activity active	Resolution activity not active
pid	As encoded in test CPR_Encode	As encoded in test CPR_Encode	As encoded in test CPR_Encode	As encoded in test CPR_Encode	As encoded in test CPR_Encode	As encoded in test CPR_Encode	As encoded in test CPR_Encode	As encoded in test CPR_Encode
lat6	As encoded in test CPR_Encode	As encoded in test CPR_Encode	As encoded in test CPR_Encode	As encoded in test CPR_Encode	As encoded in test CPR_Encode	As encoded in test CPR_Encode	As encoded in test CPR_Encode	As encoded in test CPR_Encode
nacv	0	1	2	3	Horizontal velocity error unknown	Horizontal velocity error < 10 m/s	Horizontal velocity error < 3 m/s	Horizontal velocity error < 1 m/s

ADSB_TWO_SLOT_TCP/SVQ_RF_IN_PARAMETERS(x)					ADSB_TWO_SLOT_TCP/SVQ_APPOUT_PARAMETERS(x)			
	Set P (middle range)	Set Q (min)	Set R (max)	Set S (zero)	Set P (middle range)	Set Q (min)	Set R (max)	Set S (zero)
lon6	As encoded in test CPR_Encode	As encoded in test CPR_Encode	As encoded in test CPR_Encode	As encoded in test CPR_Encode	As encoded in test CPR_Encode	As encoded in test CPR_Encode	As encoded in test CPR_Encode	As encoded in test CPR_Encode
br/gr	0	0	0	1	Barometric altitude rate	Barometric altitude rate	Barometric altitude rate	Geometric altitude rate
altr bit 9	0	0	1	1	Climbing	Climbing	Descending	Descending
altr bits 1 - 8	201	1	255	0	20 000 fpm	0 fpm	32 000 fpm	Unknown
ac	4	2	0	2	heavy a/c	medium a/c	light a/c	medium a/c
sil	0	1	2	3	Probability of exceeding the R_c integrity containment radius without detection: unknown	Probability of exceeding the R_c integrity containment radius without detection: 1×10^{-3} per flight hour or per operation	Probability of exceeding the R_c integrity containment radius without detection: 1×10^{-5} per flight hour or per operation	Probability of exceeding the R_c integrity containment radius without detection: 1×10^{-7} per flight hour or per operation
gs	1 023	1	2 047	0	1 022	0	3 069	unknown
gt	290	0	2 042	0	51 degrees	0 degree (north)	359 degrees	0 degree (north)

Table 7.18: Values for use in the test "ADSB_Single_Slot_TCP_Rec_A"

ADSB_SINGLE_SLOT_TCP_RF_IN_PARAMETERS(x)					ADSB_SINGLE_SLOT_TCP_APPOUT_PARAMETERS(x)			
	Set P (middle range)	Set Q (min)	Set R (max)	Set S (zero)	Set P (middle range)	Set Q (min)	Set R (max)	Set S (zero)
s	add_B	add_B	add_B	add_B	add_B	add_B	add_B	add_B
balt	936	2	4 072	132	8 025 feet	-1 300 feet	130 000 feet	0 feet
no	0	1	2	3	Current TCP	Next TCP	Next +1 TCP	Next +2 TCP
Patch ID	As encoded in test CPR_Enco de	As encoded in test CPR_Enco de	As encoded in test CPR_Enco de	As encoded in test CPR_Enco de	As encoded in test CPR_Encode	As encoded in test CPR_Encode	As encoded in test CPR_Encode	As encoded in test CPR_Encode
lat	As encoded in test CPR_Enco de	As encoded in test CPR_Enco de	As encoded in test CPR_Enco de	As encoded in test CPR_Enco de	As encoded in test CPR_Encode	As encoded in test CPR_Encode	As encoded in test CPR_Encode	As encoded in test CPR_Encode
lon	As encoded in test CPR_Enco de	As encoded in test CPR_Enco de	As encoded in test CPR_Enco de	As encoded in test CPR_Enco de	As encoded in test CPR_Encode	As encoded in test CPR_Encode	As encoded in test CPR_Encode	As encoded in test CPR_Encode
ttg	4	0	62	0	0,75 minute	0 minute	15,25 minutes	0 minute

Table 7.19: Values for use in the test "ADSB_Single_Slot_SVQ_Rec_A"

ADSB_SINGLE_SLOT_SVQ_RF_IN_PARAMETERS(x)					ADSB_SINGLE_SLOT_SVQ_APPOUT_PARAMETERS(x)			
	Set P (middle range)	Set Q (min)	Set R (max)	Set S (zero)	Set P (middle range)	Set Q (min)	Set R (max)	Set S (zero)
s	add_B	add_B	add_B	add_B	add_B	add_B	add_B	add_B
nacp	2	0	6	11	EPU < 7,408 Km (4 NM)	EPU ≥ 18,52 Km (10 NM)	EPU < 555,6 m (0,3 NM)	EPU < 3 m and VEPU < 4 m
sil	0	1	2	3	Probability of exceeding the R _C integrity containment radius without detection: unknown	Probability of exceeding the R _C integrity containment radius without detection: 1 × 10 ⁻³ per flight hour or per operation	Probability of exceeding the R _C integrity containment radius without detection: 1 × 10 ⁻⁵ per flight hour or per operation	Probability of exceeding the R _C integrity containment radius without detection: 1 × 10 ⁻⁷ per flight hour or per operation
nicb	1	0	1	0.	Barometric pressure altitude has been cross checked against another source of pressure altitude	Barometric pressure altitude has not been cross checked against another source of pressure altitude	Barometric pressure altitude has been cross checked against another source of pressure altitude	Barometric pressure altitude has not been cross checked against another source of pressure altitude
acas	1	1	1	1	ACAS installed and operational	ACAS installed and operational	ACAS installed and operational	ACAS installed and operational
ra	1	1	1	0	Resolution activity active	Resolution activity not active	Resolution activity active	Resolution activity not active
st	0	1	4	5	No emergency/not reported	General emergency	No communications	Unlawful interference
ac	9	12	2	2	Rotorcraft	Unmanned aerial vehicle	Medium a/c	Medium a/c

Table 7.20: Values for use in the test "ADSB_Aircraft_Data_Rec_A"

ADSB_AIRCRAFT_DATA_RF_IN_PARAMETERS(x)					ADSB_AIRCRAFT_DATA_APOUT_PARAMETERS(x)			
	Set P (middle range)	Set Q (min)	Set R (max)	Set S (zero)	Set P (middle range)	Set Q (min)	Set R (max)	Set S (zero)
s	add_B	add_B	add_B	add_B	add_B	add_B	add_B	add_B
ac	9	12	2	2	rotorcraft	unmanned aerial vehicle	medium a/c	medium a/c
st	0	1	4	5	no emergency/not reported	general emergency	no communications	unlawful interference
csi	00 00 00 00	01 01 01 01	02 02 02 02	03 03 03 03	AAAA	BBBB	CCCC	DDDD
csr	26 26 26 26	27 27 27 27	28 28 28 28	29 29 29 29	0000	1111	2222	3333

Table 7.21: Values for use in the test "ADSB_High_Resolution_Rec_A"

ADSB_HIGH_RESOLUTION_RF_IN_PARAMETERS(x)					ADSB_HIGH_RESOLUTION_APOUT_PARAMETERS(x)			
	Set P (middle range)	Set Q (min)	Set R (max)	Set S (zero)	Set P (middle range)	Set Q (min)	Set R (max)	Set S (zero)
s	add_B	add_B	add_B	add_B	add_B	add_B	add_B	add_B
sil	0	1	2	3	Probability of exceeding the R_c integrity containment radius without detection: unknown	Probability of exceeding the R_c integrity containment radius without detection: 1×10^{-3} per flight hour or per operation	Probability of exceeding the R_c integrity containment radius without detection: 1×10^{-5} per flight hour or per operation	Probability of exceeding the R_c integrity containment radius without detection: 1×10^{-7} per flight hour or per operation
gs	1 022	0	3 069	unknown	1 023	1	2 047	0
lon8	As encoded in test CPR_Deco de	As encoded in test CPR_Deco de	As encoded in test CPR_Deco de	As encoded in test CPR_Deco de	As encoded in test CPR_Deco	As encoded in test CPR_Deco	As encoded in test CPR_Deco	As encoded in test CPR_Deco
lat8	As encoded in test CPR_Deco de	As encoded in test CPR_Deco de	As encoded in test CPR_Deco de	As encoded in test CPR_Deco de	As encoded in test CPR_Deco	As encoded in test CPR_Deco	As encoded in test CPR_Deco	As encoded in test CPR_Deco
gt	51 degrees	0 degree (north)	359 degrees	0 degree (north)	290	0	2 042	0
tind	0	1	2	3	Unknown	Left	Right	Straight

Table 7.22: Values for use in the test "TIS_Manage_A"

	TIS_MANAGE_APPIN_PARAMETERS(x)				TIS_MANAGE_RF_OUT_PARAMETERS(x)			
	Set P (middle range)	Set Q (min)	Set R (max)	Set S (zero)	Set P (middle range)	Set Q (min)	Set R (max)	Set S (zero)
s	add_A	add_A	add_A	add_A	add_A	add_A	add_A	add_A
TIS-B message ID	Management message	Management message	Management message	Management message	0	0	0	0
TIS-B service version	TIS-B as defined in the present document	TIS-B as defined in the present document	TIS-B as defined in the present document	TIS-B as defined in the present document	0	0	0	0
TIV ID	2	1	4	3	1	0	3	2
Update period (s)	10 s	0,5 s	60 s	27 s	11	1	61	28
Accuracy of TIS-B targets (NM unless otherwise stated)	< 0,1 NM	< 3 m	< 10 NM	unknown	6	9	1	0
Reference point (latitude)	51 degrees 22 minutes north	51 degrees 22 minutes north	51 degrees 22 minutes north	51 degrees 22 minutes south	3 082	3 082	3 082	-3 082
Reference point (longitude)	0 degree 41 minutes west	0 degree 41 minutes west	0 degree 41 minutes west	0 degree 41 minutes west	-41	-41	-41	-41
Barometric Lower barometric altitude (ft)	18 500 ft	-1 500 ft	63 500 ft	-1 500 ft	80	0	254	0
Upper barometric altitude (ft)	38 500 ft	-1 500 ft	63 500 ft	-1 500 ft	160	0	254	0
Number of vertices	3 vertices	3 vertices	Circle with centre at reference position and radius specified by one vertex position	3 vertices	1	1	0	1
TIV1 vertex latitude	-3 degrees 56 minutes	-3 degrees 56 minutes	-3 degrees 56 minutes	-3 degrees 56 minutes	1	1	1	1
TIV1 vertex longitude	2 degrees 11 minutes	2 degrees 11 minutes	2 degrees 11 minutes	2 degrees 11 minutes	212	212	212	212
TIV2 vertex latitude	-0 degree 41 minutes	-0 degree 41 minutes	NOT TRANSMITTED	-0 degree 41 minutes	64	64		64
TIV2 vertex longitude	-3 degrees 1 minute	-3 degrees 1 minute	NOT TRANSMITTED	-3 degrees 1 minute	31	31		31
TIV3 vertex latitude	2 degrees 2 minutes	2 degrees 2 minutes	NOT TRANSMITTED	2 degrees 2 minutes	220	220		220
TIV3 vertex longitude	0 degree 5 minutes	0 degree 5 minutes	NOT TRANSMITTED	0 degree 5 minutes	130	130		130

Table 7.23: Values for use in the test "TIS_Aircraft_Air_A"

	TIS_AIRCRAFT_AIR_APPIN_PARAMETERS(x)				TIS_AIRCRAFT_AIR_RF_OUT_PARAMETERS(x)			
	Set P (middle range)	Set Q (min)	Set R (max)	Set S (zero)	Set P (middle range)	Set Q (min)	Set R (max)	Set S (zero)
s	add_A	add_A	add_A	add_A	add_A	add_A	add_A	add_A
TIS-B message ID	Aircraft target (airborne service) message	Aircraft target (airborne service) message	Aircraft target (airborne service) message	Aircraft target (airborne service) message	1	1	1	1
TIV ID	2	1	4	3	1	0	3	2
Target Identifier	0000 10 101 010 00 00 0000 0001	0000 10 101 010 00 00 0000 0010	0000 10 101 010 00 00 0000 0011	1200	0000 10 101 010 00 00 0000 0001	0000 10 101 010 00 00 0000 0010	0000 10 101 010 00 00 0000 0011	1200
Target Identifier flag	Aircraft address	Aircraft address	Aircraft address	Special Identifier	0	0	0	1
Radar fusion flag	TIS-B target based only on radar or multilat. data	TIS-B target includes ADB-B as a data source	TIS-B target based only on radar or multilat. data	TIS-B target includes ADB-B as a data source	0	1	0	1
ADS-B fault flag	NOT TRANSMITTED	ADS-B corresponds with TIS-B	NOT TRANSMITTED	ADS-B diverts from TIS-B		0		1
Latitude	50 degrees 1 minute north	50 degrees 1 minute north	50 degrees 1 minute north	50 degrees 1 minute north	-11 036	-11 036	-11 036	-11 036
Longitude	1 degree 51 minutes west	1 degree 51 minutes west	1 degree 51 minutes west	1 degree 51 minutes west	-13 173	-13 173	-13 173	-13 173
Barometric altitude	4 000 feet	-1 300 feet	130 000 feet	0 feet	532	2	4 072	132
Ground speed	1 022 knots	0 knot	3 069 knots	Unknown	1 023	1	2 047	0
Ground track	44,00 degrees	0,00 degree	359,70 degrees	0,00 degree	31	0	255	0
Time Stamp	4 000 ms after time reference	Time reference	11,8 s after time reference	Time reference	20	0	59	0
Flight ID Flag	Optional information is present	Optional information is present	Optional information is present	Optional information is not present	1	1	1	0
Flight ID type (optional)	Callsign	Registration marking (tail number)	Registration marking (tail number)		0	1	1	
Aircraft category (optional)	Rotorcraft	Highly manoeuvrable and high speed	Glider/sailplane		9	5	10	

Table 7.24: Values for use in the test "TIS_Aircraft_Grd_A"

	TIS_AIRCRAFT_GRD_APPIN_PARAMETERS(x)				TIS_AIRCRAFT_GRD_RF_OUT_PARAMETERS(x)			
	Set P (middle range)	Set Q (min)	Set R (max)	Set S (zero)	Set P (middle range)	Set Q (min)	Set R (max)	Set S (zero)
s	add_A	add_A	add_A	add_A	add_A	add_A	add_A	add_A
TIS-B message ID	Aircraft target (ground service) message	Aircraft target (ground service) message	Aircraft target (ground service) message	Aircraft target (ground service) message	2	2	2	2
TIV ID	2	1	4	3	1	0	3	2
Target Identifier	0000 10 101 010 00 00 0000 0001	0000 10 101 010 00 00 0000 0010	0000 10 101 010 00 00 0000 0011	1200	0000 10 101 010 00 00 0000 0001	0000 10 101 010 00 00 0000 0010	0000 10 101 010 00 00 0000 0011	1200
Target Identifier flag	Aircraft address	Aircraft address	Aircraft address	Special Identifier	0	0	0	1
Radar fusion flag	TIS-B target based only on radar or multilat. data	TIS-B target includes ADB-B as a data source	TIS-B target based only on radar or multilat. data	TIS-B target includes ADB-B as a data source	0	1	0	1
ADS-B fault flag	NOT TRANSMITTED	ADS-B corresponds with TIS-B	NOT TRANSMITTED	ADS-B diverts from TIS-B		0		1
Latitude (Bits 1 - 15)	50,0166 degrees	50,0166 degrees	50,0166 degrees	50,0166 degrees	-215 820	-215 820	-215 820	-215 820
Longitude (Bits 1 - 15)	1,8499 degrees	1,8499 degrees	1,8499 degrees	1,8499 degrees	-210 773	-210 773	-210 773	-210 773
Ground speed	1 022 knots	0 knot	3 069 knots	Unknown	1 023	1	2 047	0
Ground track	44,00 degrees	0,00 degree	359,70 degrees	0,00 degree	31	0	255	0
Time Stamp	4 000 ms after time reference	Time reference	11,8 s after time reference	Time reference	20	0	59	0
Flight ID Flag	Optional information is present	Optional information is present	Optional information is present	Optional information is not present	1	1	1	0
Flight ID type (optional)	Callsign	Registration marking (tail number)	Registration marking (tail number)		0	1	1	
Aircraft category (optional)	Rotorcraft	Highly manoeuvrable and high speed	Glider/sailplane		9	5	10	

Table 7.25: Values for use in the test "TIS_Grd_Veh_A"

	TIS_GRD_VEH_APPIN_PARAMETERS(x)				TIS_GRD_VEH_RF_OUT_PARAMETERS(x)			
	Set P (middle range)	Set Q (min)	Set R (max)	Set S (zero)	Set P (middle range)	Set Q (min)	Set R (max)	Set S (zero)
s	add_A	add_A	add_A	add_A	add_A	add_A	add_A	add_A
TIS-B message ID	Ground Vehicle target (ground service) message	Ground Vehicle target (ground service) message	Ground Vehicle target (ground service) message	Ground Vehicle target (ground service) message	3	3	3	3
TIV ID	2	1	4	3	1	0	3	2
Target Identifier	0000 10 101 010 00 00 0000 0001	0000 10 101 010 00 00 0000 0010	0000 10 101 010 00 00 0000 0011	1200	0000 10 101 010 00 00 0000 0001	0000 10 101 010 00 00 0000 0010	0000 10 101 010 00 00 0000 0011	1200
Target Identifier flag	Aircraft address	Aircraft address	Aircraft address	Special Identifier	0	0	0	1
Radar fusion flag	TIS-B target based only on radar or multilat. data	TIS-B target includes ADB-B as a data source	TIS-B target based only on radar or multilat. data	TIS-B target includes ADB-B as a data source	0	1	0	1
ADS-B fault flag	NOT TRANSMITTED	ADS-B corresponds with TIS-B	NOT TRANSMITTED	ADS-B diverts from TIS-B		0		1
Latitude	50,0166 degrees north	50,0166 degrees north	50,0166 degrees north	50,0166 degrees north	-215 820	-215 820	-215 820	-215 820
Longitude	1,8499 degrees west	1,8499 degrees west	1,8499 degrees west	1,8499 degrees west	-210 773	-210 773	-210 773	-210 773
Ground speed	1 022 knots	0 knot	126 knots	Unknown	1 023	1	127	0
Ground track	44,00 degrees	0,00 degree	359,70 degrees	0,00 degree	31	0	255	0
Time Stamp	4 000 ms after time reference	Time reference	11,8 s after time reference	Time reference	20	0	59	0

Table 7.26: Values for use in the test "FIS_METAR_A"

	FIS_METAR_APPIN_PARAMETERS(x)				FIS_METAR_RF_OUT_PARAMETERS(x)			
	Set P (middle range)	Set Q (min)	Set R (max)	Set S (zero)	Set P (middle range)	Set Q (min)	Set R (max)	Set S (zero)
s	add_G	add_G	add_G	add_G	add_G	add_G	add_G	add_G
fmi	METAR message	METAR message	METAR message	METAR message	0	0	0	0
vers	0	0	0	0	0	0	0	0
med	4	0	7	0	4	0	7	0
locl	EGLL	LFPG	LEBL	EDDF	05 07 12 12	12 06 16 07	12 05 02 12	05 04 04 06
date	day 16	day 1	day 31	Unknown	16	1	31	0
ti	723 minutes	0 minute	1 439 minutes	0 minute	724	1	1 440	1
wdi	150 degrees	0 degree	350 degrees	0 minute	16	1	36	1
wsp	50 kts	0 kt	100,5 kts	0 kt	51	1	102	1
ftxt	Message	None	None	Message	1	0	0	1
mxw	Gusts present	Gusts present	Gusts present	None	1	1	1	0
cav	No CAVOK	No CAVOK	No CAVOK	CAVOK	1	0	1	0
trd	TREND report present	No TREND report	TREND report present	No TREND report	1	0	1	0
pwf	2 weather fields included	1 weather field included	3 weather fields included	NOT TRANSMITTED	1	0	2	
rwf	2 weather fields included	1 weather field included	3 weather fields included	1 weather field included	1	0	2	0
qfef	Present	Present	Present	Not present	0	0	0	1
tem	+18 degrees centigrade	-79 degrees centigrade	+60 degrees centigrade	0 degree centigrade	98	1	140	80
dew	+23 degrees centigrade	-79 degrees centigrade	+60 degrees centigrade	0 degree centigrade	103	1	140	80
qnh	1 097	850,5	1 100,5	Unknown	248	1	251	0
ssf	State of the sea and sea temperature fields not present	State of the sea and sea temperature fields present	State of the sea and sea temperature fields not present	State of the sea and sea temperature fields present	1	0	1	0
vdit	160 degrees	0 degree	350 degrees	0 degree	17	1	36	1
vdif	140 degrees	0 degree	350 degrees	0 degree	15	1	36	1
wgi	49,0 kts	0,0 kts	100,5 kts	NOT TRANSMITTED	50	1	102	
mis	700 metres	0 metre	10 000 metres	NOT TRANSMITTED	14	1	45	
misd	North	North East	South West	NOT TRANSMITTED	0	1	5	
mas	850 metres	0 metre	10 000 metres	NOT TRANSMITTED	16	1	45	
masd	North West	South	East	NOT TRANSMITTED	7	4	2	
pw1	No precipitation during observation, funnel clouds	No precipitation during observation, brune-mist	No precipitation during observation, funnel clouds	NOT TRANSMITTED	18	10	18	
pw2	Precipitation during observation, heavy rain	NOT TRANSMITTED	No precipitation during observation, fog patches	NOT TRANSMITTED	64		40	

FIS_METAR_APPIN_PARAMETERS(x)					FIS_METAR_RF_OUT_PARAMETERS(x)			
	Set P (middle range)	Set Q (min)	Set R (max)	Set S (zero)	Set P (middle range)	Set Q (min)	Set R (max)	Set S (zero)
pw3	NOT TRANSMITTED	NOT TRANSMITTED	Precipitation during observation, soft hail	NOT TRANSMITTED			87	
cno	1 cloud field to follow	3 cloud fields to follow	4 cloud fields to follow	NOT TRANSMITTED	0	2	3	
ch1	2 970 metres	0 metre	20 100 metres	NOT TRANSMITTED	98	0	156	
ch2	NOT TRANSMITTED	90 metres	150 metres	NOT TRANSMITTED		2	4	
ch3	NOT TRANSMITTED	1 530 metres	19 800 metres	NOT TRANSMITTED		50	155	
ch4	NOT TRANSMITTED	NOT TRANSMITTED	2 910 metres	NOT TRANSMITTED			96	
cc1	Overcast	Few	Overcast	NOT TRANSMITTED	4	1	4	
cc2	NOT TRANSMITTED	scattered	Few	NOT TRANSMITTED		2	1	
cc3	NOT TRANSMITTED	broken	Sky clear	NOT TRANSMITTED		3	5	
cc4	NOT TRANSMITTED	NOT TRANSMITTED	Few	NOT TRANSMITTED			1	
cty1	Towering cumulus	No clouds of concern	Towering cumulus	NOT TRANSMITTED	2	0	2	
cty2	NOT TRANSMITTED	Cumulonimbus	No clouds of concern	NOT TRANSMITTED		1	0	
cty3	NOT TRANSMITTED	Towering cumulus	Cumulonimbus	NOT TRANSMITTED		2	1	
cty4	NOT TRANSMITTED	NOT TRANSMITTED	No clouds of concern	NOT TRANSMITTED			0	
qfe	1 000,5	850,5	1 100,5	Unknown	151	1	251	0
rw1	Precipitation during observation, rain and snow	No precipitation during observation, dust haze	Precipitation during observation, heavy thunderstorm	No precipitation during observation, funnel cloud	68	05	97	18
rw2	Precipitation during observation, freezing rain	NOT TRANSMITTED	Precipitation during observation, showers of rain and snow	NOT TRANSMITTED	56		83	
rw3	NOT TRANSMITTED	NOT TRANSMITTED	Precipitation during observation, ice pellets	NOT TRANSMITTED			79	
sst	+24,5 degrees centigrade	-9,5 degrees centigrade	+40 degrees centigrade	0 degree centigrade	35	1	51	11
ss	3	0	9	Unknown	4	1	10	0
txt (TREND)	TREND MESSAGE	NOT TRANSMITTED	TREND MESSAGE	NOT TRANSMITTED	TREND MESSAGE		TREND MESSAGE	TEST FREE TEXT
txt (FREE TEXT)	TEST FREE TEXT	NOT TRANSMITTED	NOT TRANSMITTED	TEST FREE TEXT	\$ TEST FREE TEXT		\$	

Table 7.27: Values for use in the test "FIS_SPECI_A"

	FIS_SPECI_APPIN_PARAMETERS(x)				FIS_SPECI_RF_OUT_PARAMETERS(x)			
	Set P (middle range)	Set Q (min)	Set R (max)	Set S (zero)	Set P (middle range)	Set Q (min)	Set R (max)	Set S (zero)
s	add_G	add_G	add_G	add_G	add_G	add_G	add_G	add_G
fmi	SPECI message	SPECI message	SPECI message	SPECI message	4	4	4	4
vers	0	0	0	0	0	0	0	0
med	3	0	7	0	3	0	7	0
locl	EGLL	LFPG	LEBL	EDDF	05 07 12 12	12 06 16 07	12 05 02 12	05 04 04 06
date	day 14	day 1	day 31	unknown	14	1	31	0
ti	698 minutes	0 minute	1 439 minutes	0 minute	699	1	1 440	1
wdi	140 degrees	0 degree	350 degrees	0 minute	15	1	36	1
wsp	45 kts	0 kts	100,5 kts	0 kts	46	1	102	1
ftxt	Message	None	None	Message	1	0	0	1
mxw	Gusts present	Gusts present	Gusts present	None	1	1	1	0
cav	No CAVOK	No CAVOK	No CAVOK	CAVOK	1	0	1	0
trd	TREND report present	No TREND report	TREND report present	No TREND report	1	0	1	0
pwf	2 weather fields included	1 weather field included	3 weather fields included	NOT TRANSMITTED	1	0	2	
rwf	2 weather fields included	1 weather field included	3 weather fields included	1 weather field included	1	0	2	0
qfef	Present	Present	Present	Not present	0	0	0	1
tem	+20 degrees centigrade	-79 degrees centigrade	+60 degrees centigrade	0 degree centigrade	100	1	140	80
dew	+22 degrees centigrade	-79 degrees centigrade	+60 degrees centigrade	0 degree centigrade	102	1	140	80
qnh	1 002,5	850,5	1 100,5	Unknown	153	1	251	0
ssf	State of the sea and sea temperature fields not present	State of the sea and sea temperature fields present	State of the sea and sea temperature fields not present	State of the sea and sea temperature fields present	1	0	1	0
vdit	150 degrees	0 degree	350 degrees	0 degree	16	1	36	1
vdif	150 degrees	0 degree	350 degrees	0 degree	16	1	36	1
wgi	46,0 kts	0,0 kts	100,5 kts	NOT TRANSMITTED	47	1	102	
mis	800 metres	0 metre	10 000 metres	NOT TRANSMITTED	16	1	45	
misd	North	North East	South West	NOT TRANSMITTED	0	1	5	
mas	1 000 metres	0 metre	10 000 metres	NOT TRANSMITTED	18	1	45	
masd	North West	South	East	NOT TRANSMITTED	7	4	2	
pw1	No precipitation during observation, funnel clouds	No precipitation during observation, brune-mist	No precipitation during observation, funnel clouds	NOT TRANSMITTED	18	10	18	

FIS_SPECI_APPIN_PARAMETERS(x)					FIS_SPECI_RF_OUT_PARAMETERS(x)			
	Set P (middle range)	Set Q (min)	Set R (max)	Set S (zero)	Set P (middle range)	Set Q (min)	Set R (max)	Set S (zero)
pw2	Precipitation during observation, heavy rain	NOT TRANSMITTED	No precipitation during observation, fog patches	NOT TRANSMITTED	64		40	
pw3	NOT TRANSMITTED	NOT TRANSMITTED	Precipitation during observation, soft hail	NOT TRANSMITTED			87	
cno	1 cloud field to follow	3 cloud fields to follow	4 cloud fields to follow	NOT TRANSMITTED	0	2	3	
ch1	2 970 metres	0 metre	20 100 metres	NOT TRANSMITTED	98	0	156	
ch2	NOT TRANSMITTED	90 metres	150 metres	NOT TRANSMITTED		2	4	
ch3	NOT TRANSMITTED	1 530 metres	19 800 metres	NOT TRANSMITTED		50	155	
ch4	NOT TRANSMITTED	NOT TRANSMITTED	2 910 metres	NOT TRANSMITTED			96	
cc1	Overcast	Few	Overcast	NOT TRANSMITTED	4	1	4	
cc2	NOT TRANSMITTED	scattered	Few	NOT TRANSMITTED		2	1	
cc3	NOT TRANSMITTED	broken	Sky clear	NOT TRANSMITTED		3	5	
cc4	NOT TRANSMITTED	NOT TRANSMITTED	Few	NOT TRANSMITTED			1	
cty1	Towering cumulus	No clouds of concern	Towering cumulus	NOT TRANSMITTED	2	0	2	
cty2	NOT TRANSMITTED	cumulonimbus	No cloud of concern	NOT TRANSMITTED		1	0	
cty3	NOT TRANSMITTED	towering cumulus	Cumulonimbus	NOT TRANSMITTED		2	1	
cty4	NOT TRANSMITTED	NOT TRANSMITTED	No cloud of concern	NOT TRANSMITTED			0	
cfe	999,5	850,5	1 100,5	NOT TRANSMITTED	150	1	251	
rw1	Precipitation during observation, rain and snow	No precipitation during observation, dust haze	Precipitation during observation, heavy thunderstorm	No precipitation during observation, funnel cloud	68	05	97	18
rw2	Precipitation during observation, freezing rain	NOT TRANSMITTED	Precipitation during observation, showers of rain and snow	NOT TRANSMITTED	56		83	
rw3	NOT TRANSMITTED	NOT TRANSMITTED	Precipitation during observation, ice pellets	NOT TRANSMITTED			79	
sst	+24,5 degrees centigrade	-9,5 degrees centigrade	+40 degrees centigrade	0 degree centigrade	35	1	51	11
ss	3	0	9	Unknown	4	1	10	0
txt (TREND)	TREND MESSGAE	NOT TRANSMITTED	TREND MESSGAE	NOT TRANSMITTED	TREND MESSAGE		TREND MESSAGE	TEST FREE TEXT
txt (FREE TEXT)	TEST FREE TEXT	NOT TRANSMITTED	NOT TRANSMITTED	TEST FREE TEXT	\$ TEST FREE TEXT		\$	

Table 7.28: Values for use in the test "FIS_ATIS_A"

	FIS ATIS_APPIN_PARAMETERS(x)				FIS ATIS_RF_OUT_PARAMETERS(x)			
	Set P (middle range)	Set Q	Set R	Set S	Set P (middle range)	Set Q (min)	Set R (max)	Set S (zero)
s	Add_G	add_G	add_G	Add_G	add_G	add_G	add_G	add_G
fmi	ATIS message	ATIS message	ATIS message	ATIS message	1	1	1	1
vers	0	0	0	0	0	0	0	0
med	3	0	7	0	3	0	7	0
locl	EGLL	LFPG	LEBL	EDDF	05 07 12 12	12 06 16 07	12 05 02 12	05 04 04 06
date	day 17	day 1	day 31	0	17	1	31	0
ti	632 minutes	1 minute	1 439 minutes	0 minute	633	2	1 440	1
hd	30 minutes	0 minute	60 minutes	0 minute	6	0	12	0
trans	100	0	300	0	21	1	61	1
oth								
aavl (bit 12)	Open	Closed	Open	Open	1	0	1	1
aavl (bits 1 - 11)	256	0	1 439	0	257	1	1 440	1
wdi	140 degrees	0 degree	350 degrees	0 degree	15	1	36	1
wsp	45 kts	0 kts	100,5 kts	0 kts	46	1	102	1
tem	+18 degrees centigrade	-79 degrees centigrade	+60 degrees centigrade	0 degree centigrade	98	1	140	80
dew	+23 degrees centigrade	-79 degrees centigrade	+60 degrees centigrade	0 degree centigrade	103	1	140	80
qnh	1 002,5	850,5	1 100,5	Unknown	153	1	251	0
ruf	3 runway fields	1 runway field	4 runway fields	2 runway fields	1	0	3	1
ftxt	Message	Message	Message	None	1	1	1	0
mxw	Gusts present	None	Gusts present	None	1	0	1	0
cav	No CAVOK	No CAVOK	No CAVOK	CAVOK	0	0	0	1
trd	Message	None	Message	Message	1	0	1	1
qfef	Present	Present	Not present	Present	0	0	1	0
pwf	2 weather fields included	1 weather field included	3 weather fields included	NOT TRANSMITTED	1	0	2	
rwf	3 weather fields included	1 weather field included	3 weather fields included	2 weather fields included	2	0	2	1
vdit	170 degrees	0 degree	350 degrees	Unknown	18	1	36	0
vdif	150 degrees	0 degree	350 degrees	Unknown	16	1	36	0
wgi	46 kts	0,1 kts	100,5 kts	0 kts	47	1	102	1
mis	775 metres	50 metres	10 500 metres	NOT TRANSMITTED	15	1	45	
misd	South East	North	South West	NOT TRANSMITTED	3	0	5	
mas	6 500 metres	50 metres	10 500 metres	NOT TRANSMITTED	41	1	45	
masd	South West	North East	West	NOT TRANSMITTED	5	1	6	
cno	2 cloud fields to follow	1 cloud field to follow	4 cloud fields to follow	NOT TRANSMITTED	1	0	3	
cc1	Broken	Few	Scattered	NOT TRANSMITTED	4	1	2	
cc2	Overcast	NOT TRANSMITTED	Broken	NOT TRANSMITTED	3		3	
cc3	NOT TRANSMITTED	NOT TRANSMITTED	Overcast	NOT TRANSMITTED			4	

FIS ATIS_APPIN_PARAMETERS(x)					FIS_ATIS_RF_OUT_PARAMETERS(x)			
	Set P (middle range)	Set Q	Set R	Set S	Set P (middle range)	Set Q (min)	Set R (max)	Set S (zero)
cc4	NOT TRANSMITTED	NOT TRANSMITTED	Sky clear	NOT TRANSMITTED			5	
ch1	2 980 metres	30 metres	20 300 metres	NOT TRANSMITTED	98	0	156	
ch2	2 980 metres	NOT TRANSMITTED	3 300 metres	NOT TRANSMITTED	98		100	
ch3	NOT TRANSMITTED	NOT TRANSMITTED	2 960 metres	NOT TRANSMITTED			97	
ch4	NOT TRANSMITTED	NOT TRANSMITTED	20 300 metres	NOT TRANSMITTED			156	
cty1	Cumulonimbus	No cloud of concern	Towering cumulus	NOT TRANSMITTED	1	0	2	
cty2	Towering Cumulus	NOT TRANSMITTED	Cumulonimbus	NOT TRANSMITTED	2		1	
cty3	NOT TRANSMITTED	NOT TRANSMITTED	No cloud of concern	NOT TRANSMITTED			0	
cty4	NOT TRANSMITTED	NOT TRANSMITTED	Towering Cumulus	NOT TRANSMITTED			2	
pw1	No precipitation during observation, blowing snow	No precipitation during observation, fume-smoke	Precipitation during observation, heavy thunderstorms	NOT TRANSMITTED	38	04	97	
pw2	No precipitation during observation, fume-smoke	NOT TRANSMITTED	No precipitation during observation, recent drizzle	NOT TRANSMITTED	04		20	
pw3	NOT TRANSMITTED	NOT TRANSMITTED	No precipitation during observation, heavy sand storm	NOT TRANSMITTED			33	
rw1	Precipitation during observation, rain and snow	No precipitation during observation, dust haze	Precipitation during observation, heavy thunderstorm	No precipitation during observation, funnel cloud	68	05	97	18
rw2	Precipitation during observation, rain	NOT TRANSMITTED	No precipitation during observation, blowing snow	No precipitation during observation, blowing snow	58		38	38
rw3	Precipitation during observation, soft hail	NOT TRANSMITTED	Precipitation during observation, heavy freezing drizzle	NOT TRANSMITTED	87		57	
qfe	1 000,5	850,5	NOT TRANSMITTED	Unknown	151	1		0
txt (TREND)	TREND MESSGAE	NOT TRANSMITTED	TREND MESSGAE	NOT TRANSMITTED	TREND MESSAGE \$ TEST FREE TEXT		TREND MESSAGE \$	TEST FREE TEXT
txt (FREE TEXT)	TEST FREE TEXT	NOT TRANSMITTED	NOT TRANSMITTED	TEST FREE TEXT				

Table 7.29: Values for use in the test "FIS_RCN_A"

FIS_RCN_APPIN_PARAMETERS(x)					FIS_RCN_RF_OUT_PARAMETERS(x)			
	Set P (middle range)	Set Q	Set R	Set S	Set P (middle range)	Set Q (min)	Set R (max)	Set S (zero)
s	Add_G	add_G	add_G	Add_G	add_G	add_G	add_G	add_G
fmi	RCN message	RCN message	RCN message	RCN message	1	1	1	1
vers	0	0	0	0	0	0	0	0
med	3	0	7	0	3	0	7	0
locl	EGLL	LFPG	LEBL	EDDF	05 07 12 12	12 06 16 07	12 05 02 12	05 04 04 06
date	day 17	day 1	day 31	0	17	1	31	0
ti	632 minutes	1 minute	1 439 minutes	0 minute	633	2	1 440	1
brk	Braking action: medium	Braking action: good	Braking action: medium/good	Figures unreliable	3	5	4	6
rdp	Damp	Clear and dry	Slush	Clear and dry	1	0	6	0
rcon	30 %	None	100 %	53 %	3	0	4	4
dod	15mm	0mm	40cm	Runway not operational due to snow, ice, large drifts or runway clearance and depth not reported	15	0	97	98
run (bits 7 - 8)	Right runway	Single runway	Single runway	Single runway	2	0	0	0
run (bits 1 - 7)	14	01	24	30	13	0	23	29
aptf	2 approach fields included	1 approach field included	3 approach fields included	1 approach field included	1	0	2	0
apty1	ILS CAT II	ILS CAT I	Visual	MLS	1	0	9	8
apty2	VOR	NOT TRANSMITTED	MLS	NOT TRANSMITTED	3		8	
apty3	NOT TRANSMITTED	NOT TRANSMITTED	VDF	NOT TRANSMITTED			7	
rrl	2 475 metres	0 metre	Full length	0 metre	50	0	255	0
rrw	32 metres	0 metre	Full width	0 metre	33	1	127	1
rdp	Negative	Negative	Positive	Positive	1	1	0	0
rvt	700 metres	0 metre	1 500 metres	NOT TRANSMITTED	23	1	32	
rvm	650 metres	0 metre	1 527 metres	NOT TRANSMITTED	22	1	32	
rve	750 metres	0 metre	1 500 metres	NOT TRANSMITTED	24	1	32	
rso	Human Observer	Unknown	Instrumented RVR system (IRVR)	Human Observer	1	0	2	1
rus	Yes - for arrivals	Yes - mixed operations	Yes - mixed operations	Yes - mixed operations	0	2	2	2
ravl (bit 12)	Open	Closed	Open	Closed	1	0	1	0
ravl (bits 1 - 11)	256	0	123	Unknown	257	1	124	0
ws	Yes	Yes	Yes	No	1	1	1	0

Table 7.30: Values for use in the test "FIS_SIGMET_A"

FIS_SIGMET_APPIN_PARAMETERS(x)					FIS_SIGMET_RF_OUT_PARAMETERS(x)			
	Set P (middle range)	Set Q (min)	Set R (max)	Set S (zero)	Set P (middle range)	Set Q (min)	Set R (max)	Set S (zero)
s	add_G	add_G	add_G	add_G	add_G	add_G	add_G	add_G
fmi	SIGMET message	SIGMET message	SIGMET message	SIGMET message	3	3	3	3
sqn	7	1	16	5	6	0	15	4
med	C	A	H	D	2	0	7	3
locl	EGLL	LFPG	LEBL	EDDF	5 7 12 12	12 06 06 07	12 05 02 12	05 04 04 06
ori	EGLL	LFPG	LEBL	EDDF	5 7 12 12	12 06 06 07	12 05 02 12	05 04 04 06
di	day 14	day 1	day 31	Unknown	14	1	31	0
ti	698 minutes	0 minute	1 439 minutes	0 minute	699	1	1 440	1
di	day 14	day 1	day 31	Unknown	14	1	31	0
ti	720 minutes	1 minutes	1 439 minutes	0 minute	721	2	1 440	1
ftxt	Message	Message	Message	None	1	1	1	0
sfl	Normal	Convective SIGMET	Normal	Convective SIGMET	0	1	0	1
crp	Heavy dust storm	Thunderstorm squall line	Condition reported in free text	Severe turbulence	17	5	0	13
txt	Test free text	Test free text	Test free text	NOT TRANSMITTED	Test free text	Test free text	Test free text	

Table 7.31: Values for use in the test "FIS_TSA_CTR_A"

FIS_TSA_CTR_APPIN_PARAMETERS(x)					FIS_TSA_CTR_RF_OUT_PARAMETERS(x)			
	Set P (middle range)	Set Q (min)	Set R (max)	Set S (zero)	Set P (middle range)	Set Q (min)	Set R (max)	Set S (zero)
s	add_G	add_G	add_G	add_G	add_G	add_G	add_G	add_G
fmi	TSA message	TSA message	TSA message	TSA message	6	6	6	6
vers	0	0	0	0	0	0	0	0
med	2	0	7	3	14	1	31	0
date	day 14	day 1	day 31	Unknown	14	1	31	0
time	698 minutes	0 minutes	1 439 minutes	0 minute	699	1	1 440	1
not	1 TSA	1 TSA	1 TSA	1 TSA	0	0	0	0
toa	Control Zone	Control Zone	Control Zone	Control Zone	0	0	0	0
act	TSA Not Active	TSA Active	TSA Active	TSA Active	0	1	1	1
locl	EGLL	LFPG	LEBL	EDDF	05 07 12 12	12 06 16 07	12 05 02 12	05 04 04 06
sloc	A	B	C	D	1	2	3	4
actdat	Day 14	Day 2	Day 1	Day 5	14	2	31	5
actim	702 minutes	5 minutes	5 minutes	55 minutes	703	6	6	56
freq	110,025	108,000	136,975	Unknown	81	1	1 160	0

Table 7.32: Values for use in the test "FIS_TSA_DNG_A"

FIS_TSA_DNG_APPIN_PARAMETERS(x)					FIS_TSA_DNG_RF_OUT_PARAMETERS(x)			
	Set P (middle range)	Set Q (min)	Set R (max)	Set S (zero)	Set P (middle range)	Set Q (min)	Set R (max)	Set S (zero)
s	add_G	add_G	add_G	add_G	add_G	add_G	add_G	add_G
fmi	TSA message	TSA message	TSA message	TSA message	6	6	6	6
vers	0	0	0	0	0	0	0	0
med	2	0	7	3	14	1	31	0
date	Day 14	Day 1	Day 31	Unknown	14	1	31	0
time	698 minutes	0 minutes	1 439 minutes	0 minute	699	1	1 440	1
not	1 TSA	1 TSA	1 TSA	1 TSA	0	0	0	0
toa	Danger zone	Restricted zone	Prohibited zone	Danger zone	2	1	3	2
act	TSA not active	TSA active	TSA active	TSA active	0	1	1	1
stid	Sweden (ES)	United Kingdom (EG)	Romania (LR)	Liechtenstein (LO)	05 19	05 07	12 18	12 15
aln	44	1	8 192	1	43	0	8 171	0
saln	D	C	B	A	4	3	2	1
actdat	Day 14	Day 2	Day 1	Day 5	14	2	31	5
actim	702 minutes	5 minutes	5 minutes	55 minutes	703	6	6	56

Table 7.33: Values for use in the tests "FIS_Request_Rec_A" and "FIS_Request_Rec_B"

FIS_REQUEST_RF_IN_PARAMETERS(x)					FIS_REQUEST_APPOUT_PARAMETERS(x)			
	Set P (middle range)	Set Q (min)	Set R (max)	Set S (zero)	Set P (middle range)	Set Q (min)	Set R (max)	Set S (zero)
s	add_G	add_G	add_G	add_G	add_G	add_G	add_G	add_G
fmi	5	5	5	5	REPORT REQUEST	REPORT REQUEST	REPORT REQUEST	REPORT REQUEST
mrq	0	3	2	1	METAR message	SIGMET message	RCN message	ATIS message
locl	05 07 12 12	12 06 06 07	12 05 02 12	05 04 04 06	EGLL	LFPG	LEBL	EDDF

Table 7.34: Values for use in the test "GNS_Type1_Message_A"

GNS_TYPE1_APPIN_PARAMETERS(x)					GNS_TYPE1_RF_OUT_PARAMETERS(x)			
	Set P (middle range)	Set Q (min)	Set R (max)	Set S (zero)	Set P (middle range)	Set Q (min)	Set R (max)	Set S (zero)
s	Add_G	add_G	add_G	Add_G	add_G	add_G	add_G	add_G
mbi	Test GNS-B message	Normal GNS-B message	Test GNS-B message	Normal GNS-B message	11111	10101	11111	10101
gid	EGLL	LFPG	LEBL	EDDF	5 7 12 12	12 06 06 07	12 05 02 12	05 04 04 06
gmi	Type 1 message	Type 1 message	Type 1 message	Type 1 message	1	1	1	1
len	28 bytes	28 bytes	28 bytes	28 bytes	28	28	28	27
amf	This is the first of two Type 1 Messages in a frame containing measurement blocks	All measurement blocks are contained in one Type 1 Message	This is the second of two Type 1 Messages in a frame containing measurement blocks	All measurement blocks are contained in one Type 1 Message	1	0	3	0
zc	01 minute 00,0 s	00 minutes 00,0 s	20 minutes 00,0 s	00 minutes 00,0 s	600	0	12 000	0
n	1 block	1 block	1 block	1 block	1	1	1	1
t	C/A or CSA code L1	C/A or CSA code L1	C/A or CSA code L1	C/A or CSA code L1	0	0	0	0
edp	5×10^{-6} m/m	0 m/m	$1,270 \times 10^{-3}$ m/m	0 m/m	2	1	255	1
ec	See clause 5.4.5.3	See clause 5.4.5.3	See clause 5.4.5.3	See clause 5.4.5.3	See clause 5.4.5.3	See clause 5.4.5.3	See clause 5.4.5.3	See clause 5.4.5.3
ad	10 s	0 s	Prediction of source availability duration not provided	0 s	1	0	255	0
id	ID2	ID1	ID138	ID1	2	1	138	1
iod	GLONASS	GPS	SBAS	GPS	1	0	2	0
prc	-327,66 m	-327,67 m	+327,67 m	0 m	1	0	65 534	32 767
rrc	-32,766 m	-32,767 m	+32,767 m	0 m	1	0	65 534	32 767
sd	0,02 m	0 m	Ranging source correction invalid	0 m	1	0	255	0
b1 (bit 8)	Negative	Positive	Negative	Positive	1	0	1	0
b1 (bits 1 - 7)	0,05 m	0 m	6,35 m	0 m	1	0	127	0
b2 (bit 8)	Negative	Positive	Negative	Positive	1	0	1	0
b2 (bits 1 - 7)	6,34 m	0 m	6,35 m	0 m	126	0	127	0
b3 (bit 8)	Reference receiver was not used to compute the pseudorange correction	Positive	Negative	Positive	1	0	1	0
b3 (bits 1 - 7)	Reference receiver was not used to compute the pseudorange correction	0 m	6,35 m	0 m	0	0	127	0
b4 (bit 8)	Positive	Positive	Negative	Positive	0	0	1	0

GNS_TYPE1_APPIN_PARAMETERS(x)					GNS_TYPE1_RF_OUT_PARAMETERS(x)			
	Set P (middle range)	Set Q (min)	Set R (max)	Set S (zero)	Set P (middle range)	Set Q (min)	Set R (max)	Set S (zero)
b4 (bits 1 - 7)	6,34 m	0 m	6,35 m	0 m	126	0	127	0
gc	See clause 5.5.5	See clause 5.5.5	See clause 5.5.5	See clause 5.5.5	See clause 5.5.5	See clause 5.5.5	See clause 5.5.5	See clause 5.5.5

Table 7.35: Values for use in the test "GNS_Type2_Message_A"

GNS_TYPE2_APPIN_PARAMETERS(x)					GNS_TYPE2_RF_OUT_PARAMETERS(x)			
	Set P (middle range)	Set Q (min)	Set R (max)	Set S (zero)	Set P (middle range)	Set Q (min)	Set R (max)	Set S (zero)
s	Add_G	add_G	add_G	Add_G	add_G	add_G	add_G	add_G
mbi	Test GNS-B message	Normal GNS-B message	Test GNS-B message	Normal GNS-B message	11111	10101	11111	10101
gid	EGLL	LFPG	LEBL	EDDF	5 7 12 12	12 06 06 07	12 05 02 12	05 04 04 06
gmi	Type 1 message	Type 1 message	Type 1 message	Type 1 message	1	1	1	1
len	28 bytes	28 bytes	28 bytes	28 bytes	28	28	28	27
r	GNS-B installed with 3 reference receivers	GNS-B installed with 2 reference receivers	GNS-B installed with 4 reference receivers	GNS-B installed with 2 reference receivers	1	0	2	0
ac	GNS-B has accuracy designation B	GNS-B has accuracy designation A	GNS-B has accuracy designation C	GNS-B has accuracy designation A	1	0	2	0
cid	GCID 1	GCID 1	GNS-B not healthy	GCID 1	1	1	7	1
v (bit 1)	Negative denotes west variation (counter-clockwise from true north)	Positive denotes eastward variation (clockwise from due north)	Negative denotes west variation (counter-clockwise from true north)	Positive denotes eastward variation (clockwise from due north)	1	0	1	0
v (bits 2 - 11)	0,25 degrees	0 degree	180,00 degrees	0 degree	1	0	720	0
vi	$0,1 \times 10^{-6}$	0	$25,5 \times 10^{-6}$	0	1	0	255	0
i (bit 8)	1	0	1	0	1	0	1	0
i (bits 1 - 7)	3	0	381	0	1	0	127	0
h	100	0	25 500	0	1	0	255	0
u	1	0	255	0	1	0	255	0
lat (bit 32)	Positive	Negative	Positive	Negative	1	0	1	0
lat (bits 1 - 31)	0 degree 0 minute 0,0005 arc s	0 degree 0 minute 0 arc s	90 degrees 0 minute 0 arc s	0 degree 0 minute 0 arc s	1	0	648 000 000	0
lon (bit 32)	Positive	Negative	Positive	Negative	1	0	1	0

GNS_TYPE2_APPIN_PARAMETERS(x)					GNS_TYPE2_RF_OUT_PARAMETERS(x)			
	Set P (middle range)	Set Q (min)	Set R (max)	Set S (zero)	Set P (middle range)	Set Q (min)	Set R (max)	Set S (zero)
lon (bits 1 - 31)	0 degree 0 minute 0,0005 arc s	0 degree 0 minute 0 arc s	180 degrees 0 minute 0 arc s	0 degree 0 minute 0 arc s	1	0	1 296 000 000	0
h (bit 24)	Positive	Negative	Positive	Negative	1	0	1	0
h (bits 1 - 23)	0,01 m	0 m	83 886,07 m	0 m	1	0	8 388 607	0
gc	See clause 5.5.5	See clause 5.5.5	See clause 5.5.5	See clause 5.5.5	See clause 5.5.5	See clause 5.5.5	See clause 5.5.5	See clause 5.5.5

Table 7.36: Values for use in the test "GNS_Type4_Message_A"

GNS_TYPE4_APPIN_PARAMETERS(x)					GNS_TYPE4_RF_OUT_PARAMETERS(x)			
	Set P (middle range)	Set Q (min)	Set R (max)	Set S (zero)	Set P (middle range)	Set Q (min)	Set R (max)	Set S (zero)
s	Add_G	add_G	add_G	Add_G	add_G	add_G	add_G	add_G
mbi	Test GNS-B message	Normal GNS-B message	Test GNS-B message	Normal GNS-B message	11111	10101	11111	10101
gid	EGLL	LFPG	LEBL	EDDF	5 7 12 12	12 06 06 07	12 05 02 12	05 04 04 06
gmi	Type 1 message	Type 1 message	Type 1 message	Type 1 message	1	1	1	1
len	51 bytes	51 bytes	51 bytes	51 bytes	51	51	51	51
l	3	2	212	2	1	0	210	0
Operation Type	1	0	15	0	1	0	15	0
SBAS provider ID	1	0	15	0	1	0	15	0
Airport ID	LFBO	EGCC	EGKK	EDDS	12 6 2 15	5 7 3 3	5 7 11 11	5 4 4 19
Runway Number	1	0	35	0	1	0	35	0
Runway Letter	Left runway	Single runway	Centre runway	Single runway	1	0	3	0
Approach performance Designator	1	0	7	0	1	0	7	0
Route Indicator	C	A	Z	A	3	1	26	1
Reference Path Data Selector	1	0	48	0	1	0	48	0
Reference Path ID	GTBS	GTCT	GTDU	GTEV	7 20 2 19	7 20 3 20	7 20 4 21	7 20 5 22
LTP/FTP Latitude (bit 32)	Positive	Negative	Positive	Negative	1	0	1	0
LTP/FTP Latitude (bits 1 - 31)	0 degree 0 minute 0,0005 arc s	0 degree 0 minute 0 arc s	90 degrees 0 minute 0 arc s	0 degree 0 minute 0 arc s	1	0	648 000 000	0
LTP/FTP Longitude (bit 32)	Positive	Negative	Positive	Negative	1	0	1	0

GNS_TYPE4_APPIN_PARAMETERS(x)					GNS_TYPE4_RF_OUT_PARAMETERS(x)			
	Set P (middle range)	Set Q (min)	Set R (max)	Set S (zero)	Set P (middle range)	Set Q (min)	Set R (max)	Set S (zero)
LTP/FTP Longitude (bits 1 - 31)	0 degree 0 minute 0,0005 arc s	0 degree 0 minute 0 arc s	180 degrees 0 minute 0 arc s	0 degree 0 minute 0 arc s	1	0	1 296 000 000	0
LTP/FTP Height	-511,9 m	-512,0 m	6 041,5 m	0,0 m	1	0	65 535	5 120
ΔFPAP Latitude (bit 24)	Positive	Negative	Positive	Negative	1	0	1	0
ΔFPAP Latitude (bits 1 - 23)	0 degree 0 minute 0,0005 arc s	0 degree 0 minute 0 arc s	1 degree 0 minute 0 arc s	0 degree 0 minute 0 arc s	1	0	1 200 000	0
ΔFPAP Longitude (bit 24)	Positive	Negative	Positive	Negative	1	0	1	0
ΔFPAP Longitude (bits 1 - 23)	0 degree 0 minute 0,0005 arc s	0 degree 0 minute 0 arc s	1 degree 0 minute 0 arc s	0 degree 0 minute 0 arc s	1	0	1 200 000	0
Approach Threshold Crossing Height (TCH)	0,05	0	1 635,35	0	1	0	32 707	0
Approach TCH Units Selector	Metres	Metres	Metres	Metres	1	1	1	1
Glidepath Angle (GPA)	0,01 degrees	0 degree	90 degrees	0 degree	1	0	9 000	0
Course width	80,25 metres	80 metres	143,75 metres	80 metres	1	0	255	0
Δlength offset	8 metres	0 metre	2 032 metres	0 metre	1	0	254	0
Final Approach Segment CRC	See clause 5.5.5.2	See clause 5.5.5.2	See clause 5.5.5.2	See clause 5.5.5.2	See clause 5.5.5.2	See clause 5.5.5.2	See clause 5.5.5.2	See clause 5.5.5.2
va	0,1	0	25,4 m	0	1	0	254	0
la	0,2	0	50,8	0	1	0	254	0
gc	See clause 5.5.5	See clause 5.5.5	See clause 5.5.5	See clause 5.5.5	See clause 5.5.5	See clause 5.5.5	See clause 5.5.5	See clause 5.5.5

7.4.3.1.5 VDL4 Burst formats

A subfield value of "x" shall mean that the parameter value may be ignored for the purpose of the particular test.

The following burst formats do not include the effect of bit stuffing. On generation of a burst at the RF PCO by the test harness, a logical 0 shall be inserted following a consecutive sequence of five logical 1s, except when arising in a flag. During recording of a burst by the test harness at the RF PCO, a sequence of five logical 1s followed by a 0 shall cause the 0 to be removed.

On generation of a burst, the test harness shall insert the value of the CRC field in accordance with clause 5.2.1.1.

Bursts are used in some test cases that are defined in EN 301 842-2 [5]. This clause defines additional bursts and frames not already defined in EN 301 842-2 [5].

7.4.3.1.5.1 Bursts defined for ADS-B tests

Table 7.37: DIR_REQ_a (Da): Contains general request

Description	Octet	Bit number							
		8	7	6	5	4	3	2	1
flag	-	0	1	1	1	1	1	1	0
s, ver, rid, a/d	1	s ₂₇	s ₂₆	s ₂₅	0	0	0	0	1
s	2	s ₂₄	s ₂₃	s ₂₂	s ₂₁	s ₂₀	s ₁₉	s ₁₈	s ₁₇
s	3	s ₁₆	s ₁₅	s ₁₄	s ₁₃	s ₁₂	s ₁₁	s ₁₀	s ₉
s	4	s ₈	s ₇	s ₆	s ₅	s ₄	s ₃	s ₂	s ₁
r-mi, mi	5	r-mi ₁	0	0	0	0	0	0	1
res, r-mi	6	0	0	r-mi ₇	r-mi ₆	r-mi ₅	r-mi ₄	r-mi ₃	r-mi ₂
dt, f	7	dt ₄	dt ₃	dt ₂	dt ₁	f ₁₂	f ₁₁	f ₁₀	f ₉
f	8	f ₈	f ₇	f ₆	f ₅	f ₄	f ₃	f ₂	f ₁
lg	9	lg ₈	lg ₇	lg ₆	lg ₅	lg ₄	lg ₃	lg ₂	lg ₁
lg, res, do	10	res	res	trmt	do ₁₃	do ₁₂	do ₁₁	do ₁₀	do ₉
do	11	do ₈	do ₇	do ₆	do ₅	do ₄	do ₃	do ₂	do ₁
or, rcvr, pr_flag, nr	12	or	rcvr ₂	rcvr ₁	pr_flag	nr ₄	nr ₃	nr ₂	nr ₁
d	13	d ₂₄	d ₂₃	d ₂₂	d ₂₁	d ₂₀	d ₁₉	d ₁₈	d ₁₇
d	14	d ₁₆	d ₁₅	d ₁₄	d ₁₃	d ₁₂	d ₁₁	d ₁₀	d ₉
d	15	d ₈	d ₇	d ₆	d ₅	d ₄	d ₃	d ₂	d ₁
erid, d	16	0	1	1	0	0	d ₂₇	d ₂₆	d ₂₅
c	17	c ₉	c ₁₀	c ₁₁	c ₁₂	c ₁₃	c ₁₄	c ₁₅	c ₁₆
c	18	c ₁	c ₂	c ₃	c ₄	c ₅	c ₆	c ₇	c ₈
flag	-	0	1	1	1	1	1	1	0

Table 7.38: DIR_SYNC_BURST_a (DSa): Directed sync burst. Occupies one slot. Basic variable part

Description	Octet	Bit number							
		8	7	6	5	4	3	2	1
flag	-	0	1	1	1	1	1	1	0
s, ver, rid, a/d	1	s ₂₇	s ₂₆	s ₂₅	0	0	0	1	1
s	2	s ₂₄	s ₂₃	s ₂₂	s ₂₁	s ₂₀	s ₁₉	s ₁₈	s ₁₇
s	3	s ₁₆	s ₁₅	s ₁₄	s ₁₃	s ₁₂	s ₁₁	s ₁₀	s ₉
s	4	s ₈	s ₇	s ₆	s ₅	s ₄	s ₃	s ₂	s ₁
nic, cprf, b/g, tqc	5	x	x	x	x	x	x	1	0
lat	6	x	x	x	x	x	x	x	x
balt	7	x	x	x	x	x	x	x	x
balt	8	x	x	x	x	x	x	x	x
lon	9	x	x	x	x	x	x	x	x
tfom, lon	10	x	x	x	x	x	x	x	x
da, id	11	x	x	x	x	0	0	0	0
in	12	x	x	x	x	x	x	x	x
in	13	x	x	x	x	x	x	x	x
in	14	x	x	x	x	x	x	x	x
in	15	x	x	x	x	x	x	x	x
in	16	x	x	x	x	x	x	x	x
in	17	x	x	x	x	x	x	x	x
in, pt	18	x	x	x	x	x	x	pt ₂	pt ₁
po	19	po ₈	po ₇	po ₆	po ₅	po ₄	po ₃	po ₂	po ₁
c	20	c ₉	c ₁₀	c ₁₁	c ₁₂	c ₁₃	c ₁₄	c ₁₅	c ₁₆
c	21	c ₁	c ₂	c ₃	c ₄	c ₅	c ₆	c ₇	c ₈
flag	-	0	1	1	1	1	1	1	0

Table 7.39: PLEA_a (Pa): Information field contains destination address. Fits within delayed burst

Description	Octet	Bit number							
		8	7	6	5	4	3	2	1
flag	-	0	1	1	1	1	1	1	0
s, ver, rid, a/d	1	s ₂₇	s ₂₆	s ₂₅	0	0	0	0	1
s	2	s ₂₄	s ₂₃	s ₂₂	s ₂₁	s ₂₀	s ₁₉	s ₁₈	s ₁₇
s	3	s ₁₆	s ₁₅	s ₁₄	s ₁₃	s ₁₂	s ₁₁	s ₁₀	s ₉
s	4	s ₈	s ₇	s ₆	s ₅	s ₄	s ₃	s ₂	s ₁
in, mi	5	0	1	0	0	0	1	0	1
d	6	d ₂₄	d ₂₃	d ₂₂	d ₂₁	d ₂₀	d ₁₉	d ₁₈	d ₁₇
d	7	d ₁₆	d ₁₅	d ₁₄	d ₁₃	d ₁₂	d ₁₁	d ₁₀	d ₉
d	8	d ₈	d ₇	d ₆	d ₅	d ₄	d ₃	d ₂	d ₁
erid, d	9	0	0	0	0	0	d ₂₇	d ₂₆	d ₂₅
c	10	c ₉	c ₁₀	c ₁₁	c ₁₂	c ₁₃	c ₁₄	c ₁₅	c ₁₆
c	11	c ₁	c ₂	c ₃	c ₄	c ₅	c ₆	c ₇	c ₈
flag	-	0	1	1	1	1	1	1	0

Table 7.40: PLEA_RESP_a (PRa): Directed request with pr_flag = 1, nr ≠ "special"

Description	Octet	Bit number							
		8	7	6	5	4	3	2	1
flag	-	0	1	1	1	1	1	1	0
s, ver, rid, a/d	1	s ₂₇	s ₂₆	s ₂₅	0	0	0	0	1
s	2	s ₂₄	s ₂₃	s ₂₂	s ₂₁	s ₂₀	s ₁₉	s ₁₈	s ₁₇
s	3	s ₁₆	s ₁₅	s ₁₄	s ₁₃	s ₁₂	s ₁₁	s ₁₀	s ₉
s	4	s ₈	s ₇	s ₆	s ₅	s ₄	s ₃	s ₂	s ₁
res, mi	5	0	1	0	0	0	1	0	1
a	6	a _{11,6}	a _{11,5}	a _{8,6}	a _{8,5}	a _{8,4}	a _{8,3}	a _{8,2}	a _{8,1}
a	7	a _{11,4}	a _{11,3}	a _{7,6}	a _{7,5}	a _{7,4}	a _{7,3}	a _{7,2}	a _{7,1}
a	8	a _{11,2}	a _{11,1}	a _{6,6}	a _{6,5}	a _{6,4}	a _{6,3}	a _{6,2}	a _{6,1}
a	9	a _{10,6}	a _{10,5}	a _{5,6}	a _{5,5}	a _{5,4}	a _{5,3}	a _{5,2}	a _{5,1}
a	10	a _{10,4}	a _{10,3}	a _{4,6}	a _{4,5}	a _{4,4}	a _{4,3}	a _{4,2}	a _{4,1}
a	11	a _{10,2}	a _{10,1}	a _{3,6}	a _{3,5}	a _{3,4}	a _{3,3}	a _{3,2}	a _{3,1}
a	12	a _{9,6}	a _{9,5}	a _{2,6}	a _{2,5}	a _{2,4}	a _{2,3}	a _{2,2}	a _{2,1}
a	13	a _{9,4}	a _{9,3}	a _{1,6}	a _{1,5}	a _{1,4}	a _{1,3}	a _{1,2}	a _{1,1}
a, off	14	a _{9,2}	a _{9,1}	off ₉	off ₈	off ₇	off ₆	off ₅	off ₄
off, pr_flag, nr	15	off ₃	off ₂	off ₁	1	nr ₄	nr ₃	nr ₂	nr ₁
d	16	d ₂₄	d ₂₃	d ₂₂	d ₂₁	d ₂₀	d ₁₉	d ₁₈	d ₁₇
d	17	d ₁₆	d ₁₅	d ₁₄	d ₁₃	d ₁₂	d ₁₁	d ₁₀	d ₉
d	18	d ₈	d ₇	d ₆	d ₅	d ₄	d ₃	d ₂	d ₁
erid, d	19	0	1	1	0	0	d ₂₇	d ₂₆	d ₂₅
c	20	c ₉	c ₁₀	c ₁₁	c ₁₂	c ₁₃	c ₁₄	c ₁₅	c ₁₆
c	21	c ₁	c ₂	c ₃	c ₄	c ₅	c ₆	c ₇	c ₈
flag	-	0	1	1	1	1	1	1	0

Table 7.41: ADSB_REQUEST_a (ARa): Includes unicast reservation, sleep = 0, auto = 0

Description	Octet	Bit number							
		8	7	6	5	4	3	2	1
flag	-	0	1	1	1	1	1	1	0
s, ver, rid a/d	1	s ₂₇	s ₂₆	s ₂₅	0	0	0	0	1
s	2	s ₂₄	s ₂₃	s ₂₂	s ₂₁	s ₂₀	s ₁₉	s ₁₈	s ₁₇
s	3	s ₁₆	s ₁₅	s ₁₄	s ₁₃	s ₁₂	s ₁₁	s ₁₀	s ₉
s	4	s ₈	s ₇	s ₆	s ₅	s ₄	s ₃	s ₂	s ₁
sleep, auto, r-b/a, burst ID	5	0	0	0	0	0	0	0	1
d	6	d ₂₄	d ₂₃	d ₂₂	d ₂₁	d ₂₀	d ₁₉	d ₁₈	d ₁₇
d	7	d ₁₆	d ₁₅	d ₁₄	d ₁₃	d ₁₂	d ₁₁	d ₁₀	d ₉
d	8	d ₈	d ₇	d ₆	d ₅	d ₄	d ₃	d ₂	d ₁
sdf, d	9	ro ₁₂	ro ₁₁	ro ₁₀	ro ₉	sdf	d ₂₇	d ₂₆	d ₂₅
ro	10	ro ₈	ro ₇	ro ₆	ro ₅	ro ₄	ro ₃	ro ₂	ro ₁
lg	11	lg ₈	lg ₇	lg ₆	lg ₅	lg ₄	lg ₃	lg ₂	lg ₁
pr	12	0	0	1	0	pr ₄	pr ₃	pr ₂	pr ₁
c	13	c ₉	c ₁₀	c ₁₁	c ₁₂	c ₁₃	c ₁₄	c ₁₅	c ₁₆
c	14	c ₁	c ₂	c ₃	c ₄	c ₅	c ₆	c ₇	c ₈
flag	-	0	1	1	1	1	1	1	0

Table 7.42: ADSB_REQUEST_b (ARb): Includes unicast reservation, sleep = 0, auto = 1

Description	Octet	Bit number							
		8	7	6	5	4	3	2	1
flag	-	0	1	1	1	1	1	1	0
s, ver, rid, a/d	1	s ₂₇	s ₂₆	s ₂₅	0	0	0	0	1
s	2	s ₂₄	s ₂₃	s ₂₂	s ₂₁	s ₂₀	s ₁₉	s ₁₈	s ₁₇
s	3	s ₁₆	s ₁₅	s ₁₄	s ₁₃	s ₁₂	s ₁₁	s ₁₀	s ₉
s	4	s ₈	s ₇	s ₆	s ₅	s ₄	s ₃	s ₂	s ₁
sleep, auto, r-b/a, burst ID	5	0	1	0	0	0	0	0	1
lg, aux, r-id	6	lg ₂	lg ₁	aux ₂	aux ₁	r-id ₄	r-id ₃	r-id ₂	r-id ₁
d	7	d ₂₄	d ₂₃	d ₂₂	d ₂₁	d ₂₀	d ₁₉	d ₁₈	d ₁₇
d	8	d ₁₆	d ₁₅	d ₁₄	d ₁₃	d ₁₂	d ₁₁	d ₁₀	d ₉
d	9	d ₈	d ₇	d ₆	d ₅	d ₄	d ₃	d ₂	d ₁
sdf, d	10	ro ₁₂	ro ₁₁	ro ₁₀	ro ₉	sdf	d ₂₇	d ₂₆	d ₂₅
ro	11	ro ₈	ro ₇	ro ₆	ro ₅	ro ₄	ro ₃	ro ₂	ro ₁
lg	12	lg ₈	lg ₇	lg ₆	lg ₅	lg ₄	lg ₃	lg ₂	lg ₁
pr	13	0	0	1	0	pr ₄	pr ₃	pr ₂	pr ₁
c	14	c ₉	c ₁₀	c ₁₁	c ₁₂	c ₁₃	c ₁₄	c ₁₅	c ₁₆
c	15	c ₁	c ₂	c ₃	c ₄	c ₅	c ₆	c ₇	c ₈
flag	-	0	1	1	1	1	1	1	0

Table 7.43: ADSB_REQUEST_c (ARc): Includes directed request reservation, sleep = 1, auto = 0

Description	Octet	Bit number							
		8	7	6	5	4	3	2	1
flag	-	0	1	1	1	1	1	1	0
s, ver, rid, a/d	1	s ₂₇	s ₂₆	s ₂₅	0	0	0	0	1
s	2	s ₂₄	s ₂₃	s ₂₂	s ₂₁	s ₂₀	s ₁₉	s ₁₈	s ₁₇
s	3	s ₁₆	s ₁₅	s ₁₄	s ₁₃	s ₁₂	s ₁₁	s ₁₀	s ₉
s	4	s ₈	s ₇	s ₆	s ₅	s ₄	s ₃	s ₂	s ₁
sleep, auto, r-b/a, burst ID	5	1	0	0	0	0	0	0	1
snr, vel	6	snr ₄	snr ₃	snr ₂	snr ₁	vel ₄	vel ₃	vel ₂	vel ₁
pos	7	pos ₈	pos ₇	pos ₆	pos ₅	pos ₄	pos ₃	pos ₂	pos ₁
dt	8	dt ₄	dt ₃	dt ₂	dt ₁	f ₁₂	f ₁₁	f ₁₀	f ₉
f	9	f ₈	f ₇	f ₆	f ₅	f ₄	f ₃	f ₂	f ₁
lg	10	lg ₈	lg ₇	lg ₆	lg ₅	lg ₄	lg ₃	lg ₂	lg ₁
trmt	11	res	res	trmt	do ₁₃	do ₁₂	do ₁₁	do ₁₀	do ₉
do	12	do ₈	do ₇	do ₆	do ₅	do ₄	do ₃	do ₂	do ₁
or; rcvr, nr; pr_flag = 0	13	or	rcvr ₂	rcvr ₁	0	nr ₄	nr ₃	nr ₂	nr ₁
d	14	d ₂₄	d ₂₃	d ₂₂	d ₂₁	d ₂₀	d ₁₉	d ₁₈	d ₁₇
d	15	d ₁₆	d ₁₅	d ₁₄	d ₁₃	d ₁₂	d ₁₁	d ₁₀	d ₉
d	16	d ₈	d ₇	d ₆	d ₅	d ₄	d ₃	d ₂	d ₁
erid	17	0	1	1	0	0	d ₂₇	d ₂₆	d ₂₅
c	18	c ₉	c ₁₀	c ₁₁	c ₁₂	c ₁₃	c ₁₄	c ₁₅	c ₁₆
c	19	c ₁	c ₂	c ₃	c ₄	c ₅	c ₆	c ₇	c ₈
flag	-	0	1	1	1	1	1	1	0

Table 7.44: ADSB_REQUEST_d (ARd) Includes directed request reservation, sleep = 1, auto = 1

Description	Octet	Bit number							
		8	7	6	5	4	3	2	1
flag	-	0	1	1	1	1	1	1	0
s, ver, rid, a/d	1	s ₂₇	s ₂₆	s ₂₅	0	0	0	0	1
s	2	s ₂₄	s ₂₃	s ₂₂	s ₂₁	s ₂₀	s ₁₉	s ₁₈	s ₁₇
s	3	s ₁₆	s ₁₅	s ₁₄	s ₁₃	s ₁₂	s ₁₁	s ₁₀	s ₉
s	4	s ₈	s ₇	s ₆	s ₅	s ₄	s ₃	s ₂	s ₁
sleep, auto, r-b/a, burst ID	5	1	1	0	0	0	0	0	1
snr, vel	6	snr ₄	snr ₃	snr ₂	snr ₁	vel ₄	vel ₃	vel ₂	vel ₁
pos	7	pos ₈	pos ₇	pos ₆	pos ₅	pos ₄	pos ₃	pos ₂	pos ₁
lg, aux, r-id	8	lg ₂	lg ₁	aux ₂	aux ₁	r-id ₄	r-id ₃	r-id ₂	r-id ₁
dt	9	dt ₄	dt ₃	dt ₂	dt ₁	f ₁₂	f ₁₁	f ₁₀	f ₉
f	10	f ₈	f ₇	f ₆	f ₅	f ₄	f ₃	f ₂	f ₁
lg	11	lg ₈	lg ₇	lg ₆	lg ₅	lg ₄	lg ₃	lg ₂	lg ₁
trmt	12	res	res	trmt	do ₁₃	do ₁₂	do ₁₁	do ₁₀	do ₉
do	13	do ₈	do ₇	do ₆	do ₅	do ₄	do ₃	do ₂	do ₁
or; rcvr, nr; pr_flag = 0	14	or	rcvr ₂	rcvr ₁	0	nr ₄	nr ₃	nr ₂	nr ₁
d	15	d ₂₄	d ₂₃	d ₂₂	d ₂₁	d ₂₀	d ₁₉	d ₁₈	d ₁₇
d	16	d ₁₆	d ₁₅	d ₁₄	d ₁₃	d ₁₂	d ₁₁	d ₁₀	d ₉
d	17	d ₈	d ₇	d ₆	d ₅	d ₄	d ₃	d ₂	d ₁
erid	18	0	1	1	0	0	d ₂₇	d ₂₆	d ₂₅
c	19	c ₉	c ₁₀	c ₁₁	c ₁₂	c ₁₃	c ₁₄	c ₁₅	c ₁₆
c	20	c ₁	c ₂	c ₃	c ₄	c ₅	c ₆	c ₇	c ₈
flag	-	0	1	1	1	1	1	1	0

Table 7.45: ADSB_REQUEST_e (ARe) Includes directed request reservation, sleep = 0, auto = 1

Description	Octet	Bit number							
		8	7	6	5	4	3	2	1
flag	-	0	1	1	1	1	1	1	0
s, ver, rid, a/d	1	s ₂₇	s ₂₆	s ₂₅	0	0	0	0	1
s	2	s ₂₄	s ₂₃	s ₂₂	s ₂₁	s ₂₀	s ₁₉	s ₁₈	s ₁₇
s	3	s ₁₆	s ₁₅	s ₁₄	s ₁₃	s ₁₂	s ₁₁	s ₁₀	s ₉
s	4	s ₈	s ₇	s ₆	s ₅	s ₄	s ₃	s ₂	s ₁
sleep, auto, r-b/a, burst ID	5	0	1	0	0	0	0	0	1
lg, aux, r-id	6	lg ₂	lg ₁	aux ₂	aux ₁	r-id ₄	r-id ₃	r-id ₂	r-id ₁
dt	7	dt ₄	dt ₃	dt ₂	dt ₁	f ₁₂	f ₁₁	f ₁₀	f ₉
f	8	f ₈	f ₇	f ₆	f ₅	f ₄	f ₃	f ₂	f ₁
lg	9	lg ₈	lg ₇	lg ₆	lg ₅	lg ₄	lg ₃	lg ₂	lg ₁
trmt	10	res	res	trmt	do ₁₃	do ₁₂	do ₁₁	do ₁₀	do ₉
do	11	do ₈	do ₇	do ₆	do ₅	do ₄	do ₃	do ₂	do ₁
or; rcvr, nr; pr_flag = 0	12	or	rcvr ₂	rcvr ₁	0	nr ₄	nr ₃	nr ₂	nr ₁
d	13	d ₂₄	d ₂₃	d ₂₂	d ₂₁	d ₂₀	d ₁₉	d ₁₈	d ₁₇
d	14	d ₁₆	d ₁₅	d ₁₄	d ₁₃	d ₁₂	d ₁₁	d ₁₀	d ₉
d	15	d ₈	d ₇	d ₆	d ₅	d ₄	d ₃	d ₂	d ₁
erid	16	0	1	1	0	0	d ₂₇	d ₂₆	d ₂₅
c	17	c ₉	c ₁₀	c ₁₁	c ₁₂	c ₁₃	c ₁₄	c ₁₅	c ₁₆
c	18	c ₁	c ₂	c ₃	c ₄	c ₅	c ₆	c ₇	c ₈
flag	-	0	1	1	1	1	1	1	0

**Table 7.46: DIR_SYNC_BURST_b (DSb): Directed sync burst. Occupies one slot.
Full position variable part**

Description	Octet	Bit number							
		8	7	6	5	4	3	2	1
flag	-	0	1	1	1	1	1	1	0
s, ver, rid, a/d	1	s ₂₇	s ₂₆	s ₂₅	0	0	0	1	1
s	2	s ₂₄	s ₂₃	s ₂₂	s ₂₁	s ₂₀	s ₁₉	s ₁₈	s ₁₇
s	3	s ₁₆	s ₁₅	s ₁₄	s ₁₃	s ₁₂	s ₁₁	s ₁₀	s ₉
s	4	s ₈	s ₇	s ₆	s ₅	s ₄	s ₃	s ₂	s ₁
nic, cprf, b/g, tqc	5	x	x	x	x	x	x	1	0
lat	6	x	x	x	x	x	x	x	x
balt	7	x	x	x	x	x	x	x	x
balt	8	x	x	x	x	x	x	x	x
lon	9	x	x	x	x	x	x	x	x
tfom, lon	10	x	x	x	x	x	x	x	x
da, id	11	x	x	x	x	0	0	1	0
in	12	x	x	x	x	x	x	x	x
in	13	x	x	x	x	x	x	x	x
in	14	x	x	x	x	x	x	x	x
in	15	x	x	x	x	x	x	x	x
in	16	x	x	x	x	x	x	x	x
in	17	x	x	x	x	x	x	x	x
in, pt	18	x	x	x	x	x	x	pt ₂	pt ₁
po	19	po ₈	po ₇	po ₆	po ₅	po ₄	po ₃	po ₂	po ₁
c	20	c ₉	c ₁₀	c ₁₁	c ₁₂	c ₁₃	c ₁₄	c ₁₅	c ₁₆
c	21	c ₁	c ₂	c ₃	c ₄	c ₅	c ₆	c ₇	c ₈
flag	-	0	1	1	1	1	1	1	0

**Table 7.47: DIR_SYNC_BURST_c (DSc): Directed sync burst. Occupies one slot.
Two-slot TCP variable part**

Description	Octet	Bit number							
		8	7	6	5	4	3	2	1
flag	-	0	1	1	1	1	1	1	0
s, ver, rid, a/d	1	s ₂₇	s ₂₆	s ₂₅	0	0	0	1	1
s	2	s ₂₄	s ₂₃	s ₂₂	s ₂₁	s ₂₀	s ₁₉	s ₁₈	s ₁₇
s	3	s ₁₆	s ₁₅	s ₁₄	s ₁₃	s ₁₂	s ₁₁	s ₁₀	s ₉
s	4	s ₈	s ₇	s ₆	s ₅	s ₄	s ₃	s ₂	s ₁
nic, cprf, b/g, tqc	5	x	x	x	x	x	x	1	0
lat	6	x	x	x	x	x	x	x	x
balt	7	x	x	x	x	x	x	x	x
balt	8	x	x	x	x	x	x	x	x
lon	9	x	x	x	x	x	x	x	x
tfom, lon	10	x	x	x	x	x	x	x	x
da, id	11	x	x	x	x	1	0	0	0
in	12	x	x	x	x	x	x	x	x
in	13	x	x	x	x	x	x	x	x
in	14	x	x	x	x	x	x	x	x
in	15	x	x	x	x	x	x	x	x
in	16	x	x	x	x	x	x	x	x
in	17	x	x	x	x	x	x	x	x
in	18	x	x	x	x	x	x	x	x
in	19	x	x	x	x	x	x	x	x
in	20	x	x	x	x	x	x	x	x
in	21	x	x	x	x	x	x	x	x
in	22	x	x	x	x	x	x	x	x
in	23	x	x	x	x	x	x	x	x
in	24	x	x	x	x	x	x	x	x
in	25	x	x	x	x	x	x	x	x
in	26	x	x	x	x	x	x	x	x
in	27	x	x	x	x	x	x	x	x
in	28	x	x	x	x	x	x	x	x
in	29	x	x	x	x	x	x	x	x
in	30	x	x	x	x	x	x	x	x
in	31	x	x	x	x	x	x	x	x
in	32	x	x	x	x	x	x	x	x
in	33	x	x	x	x	x	x	x	x
in	34	x	x	x	x	x	x	x	x
in	35	x	x	x	x	x	x	x	x
in	36	x	x	x	x	x	x	x	x
in	37	x	x	x	x	x	x	x	x
in	38	x	x	x	x	x	x	x	x
in	39	x	x	x	x	x	x	x	x
in	40	x	x	x	x	x	x	x	x
in	41	x	x	x	x	x	x	x	x
in	42	x	x	x	x	x	x	x	x
in	43	x	x	x	x	x	x	x	x
in	44	x	x	x	x	x	x	x	x
in	45	x	x	x	x	x	x	x	x
in	46	x	x	x	x	x	x	x	x
in	47	x	x	x	x	x	x	x	x
in	48	x	x	x	x	x	x	x	x
in, pt	49	x	x	x	x	x	x	pt ₂	pt ₁
po	50	po ₈	po ₇	po ₆	po ₅	po ₄	po ₃	po ₂	po ₁
c	51	c ₉	c ₁₀	c ₁₁	c ₁₂	c ₁₃	c ₁₄	c ₁₅	c ₁₆
c	52	c ₁	c ₂	c ₃	c ₄	c ₅	c ₆	c ₇	c ₈
flag	-	0	1	1	1	1	1	1	0

Table 7.48: DIR_SYNC_BURST_d (DSd): Directed sync burst. Occupies one slot. High dynamic variable part

Description	Octet	Bit number							
		8	7	6	5	4	3	2	1
flag	-	0	1	1	1	1	1	1	0
s, ver, rid, a/d	1	s ₂₇	s ₂₆	s ₂₅	0	0	0	1	1
s	2	s ₂₄	s ₂₃	s ₂₂	s ₂₁	s ₂₀	s ₁₉	s ₁₈	s ₁₇
s	3	s ₁₆	s ₁₅	s ₁₄	s ₁₃	s ₁₂	s ₁₁	s ₁₀	s ₉
s	4	s ₈	s ₇	s ₆	s ₅	s ₄	s ₃	s ₂	s ₁
nic, cprf, b/g, tqc	5	x	x	x	x	x	x	1	0
lat	6	x	x	x	x	x	x	x	x
balt	7	x	x	x	x	x	x	x	x
balt	8	x	x	x	x	x	x	x	x
lon	9	x	x	x	x	x	x	x	x
tfom, lon	10	x	x	x	x	x	x	x	x
da, id	11	x	x	x	x	0	0	0	1
in	12	x	x	x	x	x	x	x	x
in	13	x	x	x	x	x	x	x	x
in	14	x	x	x	x	x	x	x	x
in	15	x	x	x	x	x	x	x	x
in	16	x	x	x	x	x	x	x	x
in	17	x	x	x	x	x	x	x	x
in, pt	18	x	x	x	x	x	x	pt ₂	pt ₁
po	19	po ₈	po ₇	po ₆	po ₅	po ₄	po ₃	po ₂	po ₁
c	20	c ₉	c ₁₀	c ₁₁	c ₁₂	c ₁₃	c ₁₄	c ₁₅	c ₁₆
c	21	c ₁	c ₂	c ₃	c ₄	c ₅	c ₆	c ₇	c ₈
flag	-	0	1	1	1	1	1	1	0

Table 7.49: CTRL_CHAN_k (Cck): Channel management burst with 1 header, 1 destination, 1 transmission, 1 frequency, 1 parameter and 1 script block

Description	Octet	Bit number							
		8	7	6	5	4	3	2	1
flag	-	0	1	1	1	1	1	1	0
s, ver, rid, a/d	1	s ₂₇	s ₂₆	s ₂₅	ver ₃	ver ₂	ver ₁	rid	a/d
s	2	s ₂₄	s ₂₃	s ₂₂	s ₂₁	s ₂₀	s ₁₉	s ₁₈	s ₁₇
s	3	s ₁₆	s ₁₅	s ₁₄	s ₁₃	s ₁₂	s ₁₁	s ₁₀	s ₉
s	4	s ₈	s ₇	s ₆	s ₅	s ₄	s ₃	s ₂	s ₁
res, mi	5	0	0	1	1	0	0	0	1
ucid, UCTRL DLPDU	6	0	0	1	0	0	1	0	0
n	7	n ₈	n ₇	n ₆	n ₅	n ₄	n ₃	n ₂	n ₁
dt	8	dt ₄	dt ₃	dt ₂	dt ₁	do ₁₂	do ₁₁	do ₁₀	do ₉
do	9	do ₈	do ₇	do ₆	do ₅	do ₄	do ₃	do ₂	do ₁
dc	10	dc ₈	dc ₇	dc ₆	dc ₅	dc ₄	dc ₃	dc ₂	dc ₁
csid, tc	11	csid ₄	csid ₃	csid ₂	csid ₁	tc ₄	tc ₃	tc ₂	tc ₁
fc,styp,sr	12	fc ₃	fc ₂	fc ₁	styp	sr ₄	sr ₃	sr ₂	sr ₁
pc	13	res	res	pc ₆	pc ₅	pc ₄	pc ₃	pc ₂	pc ₁
sc	14	sc ₈	sc ₇	sc ₆	sc ₅	sc ₄	sc ₃	sc ₂	sc ₁
ido	15	0	ido ₄	ido ₃	ido ₂	ido ₁	d ₂₇	d ₂₆	d ₂₅
d	16	d ₂₄	d ₂₃	d ₂₂	d ₂₁	d ₂₀	d ₁₉	d ₁₈	d ₁₇
d	17	d ₁₆	d ₁₅	d ₁₄	d ₁₃	d ₁₂	d ₁₁	d ₁₀	d ₉
d	18	d ₈	d ₇	d ₆	d ₅	d ₄	d ₃	d ₂	d ₁
id	19	id ₄	id ₃	id ₂	id ₁	aux	b/g	res	0
flags	20	sleep	auto	rcv	res	f ₁₂	f ₁₁	f ₁₀	f ₉
freq	21	f ₈	f ₇	f ₆	f ₅	f ₄	f ₃	f ₂	f ₁
Q1, Q4	22	Q1 ₂	Q1 ₁	res	Q4 ₅	Q4 ₄	Q4 ₃	Q4 ₂	Q4 ₁
Q2 _a	23	Q2a ₈	Q2a ₇	Q2a ₆	Q2a ₅	Q2a ₄	Q2a ₃	Q2a ₂	Q2a ₁
	24	Q2a ₁₂	Q2a ₁₁	Q2a ₁₀	Q2a ₉	Q2b ₁₂	Q2b ₁₁	Q2b ₁₀	Q2b ₉
Q2b	25	Q2b ₈	Q2b ₇	Q2b ₆	Q2b ₅	Q2b ₄	Q2b ₃	Q2b ₂	Q2b ₁
Q2c	26	Q2c ₈	Q2c ₇	Q2c ₆	Q2c ₅	Q2c ₄	Q2c ₃	Q2c ₂	Q2c ₁
	27	Q2c ₁₂	Q2c ₁₁	Q2c ₁₀	Q2c ₉	Q2d ₁₂	Q2d ₁₁	Q2d ₁₀	Q2d ₉
Q2d	28	Q2d ₈	Q2d ₇	Q2d ₆	Q2d ₅	Q2d ₄	Q2d ₃	Q2d ₂	Q2d ₁
TV11min, TV11max	29	TV11min ₄	TV11min ₃	TV11min ₂	TV11min ₁	TV11max ₄	TV11max ₃	TV11max ₂	TV11max ₁
V11	30	res	res	V11 ₆	V11 ₅	V11 ₄	V11 ₃	V11 ₂	V11 ₁

Description	Octet	Bit number							
		8	7	6	5	4	3	2	1
V12	31	res	V12 ₇	V12 ₆	V12 ₅	V12 ₄	V12 ₃	V12 ₂	V12 ₁
VS2	32	res	res	VS2 ₆	VS2 ₅	VS2 ₄	VS2 ₃	VS2 ₂	VS2 ₁
VS4	33	res	VS4 ₇	VS4 ₆	VS4 ₅	VS4 ₄	VS4 ₃	VS4 ₂	VS4 ₁
frq, nsd, txd	34	frq ₃	frq ₂	frq ₁	nsd	txd ₄	txd ₃	txd ₂	txd ₁
erid	35	0	1	1	0	0	d ₂₇	d ₂₆	d ₂₅
c	36	c ₉	c ₁₀	c ₁₁	c ₁₂	c ₁₃	c ₁₄	c ₁₅	c ₁₆
c	37	c ₁	c ₂	c ₃	c ₄	c ₅	c ₆	c ₇	c ₈
flag	-	0	1	1	1	1	1	1	0

Table 7.50: CTRL_CHAN_p (CCp): Channel management burst with 1 header, a regional multicast, 1 transmission, 1 frequency, 1 parameter and 1 script block

Description	Octet	Bit number							
		8	7	6	5	4	3	2	1
flag	-	0	1	1	1	1	1	1	0
s, ver, rid, a/d	1	s ₂₇	s ₂₆	s ₂₅	ver ₃	ver ₂	ver ₁	rid	a/d
s	2	s ₂₄	s ₂₃	s ₂₂	s ₂₁	s ₂₀	s ₁₉	s ₁₈	s ₁₇
s	3	s ₁₆	s ₁₅	s ₁₄	s ₁₃	s ₁₂	s ₁₁	s ₁₀	s ₉
s	4	s ₈	s ₇	s ₆	s ₅	s ₄	s ₃	s ₂	s ₁
res, mi	5	0	0	1	1	0	0	0	1
ucid, UCTRL DLPDU	6	0	0	1	0	0	1	0	0
n	7	n ₈	n ₇	n ₆	n ₅	n ₄	n ₃	n ₂	n ₁
dt	8	dt ₄	dt ₃	dt ₂	dt ₁	do ₁₂	do ₁₁	do ₁₀	do ₉
do	9	do ₈	do ₇	do ₆	do ₅	do ₄	do ₃	do ₂	do ₁
dc	10	dc ₈	dc ₇	dc ₆	dc ₅	dc ₄	dc ₃	dc ₂	dc ₁
csid, tc	11	csid ₄	csid ₃	csid ₂	csid ₁	tc ₄	tc ₃	tc ₂	tc ₁
fc,styp,sr	12	fc ₃	fc ₂	fc ₁	styp	sr ₄	sr ₃	sr ₂	sr ₁
pc	13	res	res	pc ₆	pc ₅	pc ₄	pc ₃	pc ₂	pc ₁
sc	14	sc ₈	sc ₇	sc ₆	sc ₅	sc ₄	sc ₃	sc ₂	sc ₁
vc, lon	15	1	res	lon ₁₄	lon ₁₃	vc ₄	vc ₃	vc ₂	vc ₁
lon	16	lon ₈	lon ₇	lon ₆	lon ₅	lon ₄	lon ₃	lon ₂	lon ₁
lon, lat	17	lon ₁₂	lon ₁₁	lon ₁₀	lon ₉	lat ₁₂	lat ₁₁	lat ₁₀	lat ₉
lat	18	lat ₈	lat ₇	lat ₆	lat ₅	lat ₄	lat ₃	lat ₂	lat ₁
lon4, lat4	19	lon ₄₄	lon ₄₃	lon ₄₂	lon ₄₁	lat ₄₄	lat ₄₃	lat ₄₂	lat ₄₁
lalt	20	lalt ₈	lalt ₇	lalt ₆	lalt ₅	lalt ₄	lalt ₃	lalt ₂	lalt ₁

Description	Octet	Bit number							
		8	7	6	5	4	3	2	1
uall	21	uall ₈	uall ₇	uall ₆	uall ₅	uall ₄	uall ₃	uall ₂	uall ₁
v1r1	22	r _{1,8}	r _{1,7}	r _{1,6}	r _{1,5}	r _{1,4}	r _{1,3}	r _{1,2}	r _{1,1}
v1d1	23	d _{1,8}	d _{1,7}	d _{1,6}	d _{1,5}	d _{1,4}	d _{1,3}	d _{1,2}	d _{1,1}
v2r2	24	r _{2,8}	r _{2,7}	r _{2,6}	r _{2,5}	r _{2,4}	r _{2,3}	r _{2,2}	r _{2,1}
v2d2	25	d _{2,8}	d _{2,7}	d _{2,6}	d _{2,5}	d _{2,4}	d _{2,3}	d _{2,2}	d _{2,1}
flags	26	sleep	auto	rcv	res	f ₁₂	f ₁₁	f ₁₀	f ₉
freq	27	f ₈	f ₇	f ₆	f ₅	f ₄	f ₃	f ₂	f ₁
Q1, Q4	28	Q1 ₂	Q1 ₁	res	Q4 ₅	Q4 ₄	Q4 ₃	Q4 ₂	Q4 ₁
Q2 _a	29	Q2a ₈	Q2a ₇	Q2a ₆	Q2a ₅	Q2a ₄	Q2a ₃	Q2a ₂	Q2a ₁
	30	Q2a ₁₂	Q2a ₁₁	Q2a ₁₀	Q2a ₉	Q2b ₁₂	Q2b ₁₁	Q2b ₁₀	Q2b ₉
Q2 _b	31	Q2b ₈	Q2b ₇	Q2b ₆	Q2b ₅	Q2b ₄	Q2b ₃	Q2b ₂	Q2b ₁
Q2 _c	32	Q2c ₈	Q2c ₇	Q2c ₆	Q2c ₅	Q2c ₄	Q2c ₃	Q2c ₂	Q2c ₁
	33	Q2c ₁₂	Q2c ₁₁	Q2c ₁₀	Q2c ₉	Q2d ₁₂	Q2d ₁₁	Q2d ₁₀	Q2d ₉
Q2 _d	34	Q2d ₈	Q2d ₇	Q2d ₆	Q2d ₅	Q2d ₄	Q2d ₃	Q2d ₂	Q2d ₁
TV11min, TV11max	35	TV11min ₄	TV11min ₃	TV11min ₂	TV11min ₁	TV11max ₄	TV11max ₃	TV11max ₂	TV11max ₁
V11	36	res	res	V11 ₆	V11 ₅	V11 ₄	V11 ₃	V11 ₂	V11 ₁
V12	37	res	V12 ₇	V12 ₆	V12 ₅	V12 ₄	V12 ₃	V12 ₂	V12 ₁
VS2	38	res	res	VS2 ₆	VS2 ₅	VS2 ₄	VS2 ₃	VS2 ₂	VS2 ₁
VS4	39	res	VS4 ₇	VS4 ₆	VS4 ₅	VS4 ₄	VS4 ₃	VS4 ₂	VS4 ₁
frq, nsd, txd	40	frq ₃	frq ₂	frq ₁	nsd	txd ₄	txd ₃	txd ₂	txd ₁
erid	41	0	1	1	0	0	d ₂₇	d ₂₆	d ₂₅
c	42	c ₉	c ₁₀	c ₁₁	c ₁₂	c ₁₃	c ₁₄	c ₁₅	c ₁₆
c	43	c ₁	c ₂	c ₃	c ₄	c ₅	c ₆	c ₇	c ₈
flag	-	0	1	1	1	1	1	1	0

Table 7.51: SYNC_BASIC_a (SBa): Basic variable part. Occupies one slot

Description	Octet	Bit number							
		8	7	6	5	4	3	2	1
flag	-	0	1	1	1	1	1	1	0
s, ver, rid, a/d	1	s ₂₇	s ₂₆	s ₂₅	0	0	0	1	0
s	2	s ₂₄	s ₂₃	s ₂₂	s ₂₁	s ₂₀	s ₁₉	s ₁₈	s ₁₇
s	3	s ₁₆	s ₁₅	s ₁₄	s ₁₃	s ₁₂	s ₁₁	s ₁₀	s ₉
s	4	s ₈	s ₇	s ₆	s ₅	s ₄	s ₃	s ₂	s ₁
nic, cprf, b/g, tqc	5	nic ₄	nic ₃	nic ₂	nic ₁	cprf	b/g	1	0
lat	6	lat ₈	lat ₇	lat ₆	lat ₅	lat ₄	lat ₃	lat ₂	lat ₁
balt	7	balt ₁₂	balt ₁₁	balt ₁₀	balt ₉	lat ₁₂	lat ₁₁	lat ₁₀	lat ₉
balt	8	balt ₈	balt ₇	balt ₆	balt ₅	balt ₄	balt ₃	balt ₂	balt ₁
lon	9	lon ₈	lon ₇	lon ₆	lon ₅	lon ₄	lon ₃	lon ₂	lon ₁
tfom, lon	10	tfom ₂	tfom ₁	lon ₁₄	lon ₁₃	lon ₁₂	lon ₁₁	lon ₁₀	lon ₉
da, id	11	da ₄	da ₃	da ₂	da ₁	0	0	0	0
sil, lat6	12	sil ₂	sil ₁	lat ₆ ₆	lat ₆ ₅	lat ₆ ₄	lat ₆ ₃	lat ₆ ₂	lat ₆ ₁
br/gr, lon6	13	res ₃	br/gr	lon ₆ ₆	lon ₆ ₅	lon ₆ ₄	lon ₆ ₃	lon ₆ ₂	lon ₆ ₁
altr, bgo	14	altr ₉	bgo ₇	bgo ₆	bgo ₅	bgo ₄	bgo ₃	bgo ₂	bgo ₁
altr	15	altr ₈	altr ₇	altr ₆	altr ₅	altr ₄	altr ₃	altr ₂	altr ₁
gs	16	gs ₈	gs ₇	gs ₆	gs ₅	gs ₄	gs ₃	gs ₂	gs ₁
gs, gt	17	gs ₁₁	gs ₁₀	gs ₉	gt ₅	gt ₄	gt ₃	gt ₂	gt ₁
gt, pt	18	gt ₁₁	gt ₁₀	gt ₉	gt ₈	gt ₇	gt ₆	pt ₂	pt ₁
po	19	po ₈	po ₇	po ₆	po ₅	po ₄	po ₃	po ₂	po ₁
c	20	c ₉	c ₁₀	c ₁₁	c ₁₂	c ₁₃	c ₁₄	c ₁₅	c ₁₆
c	21	c ₁	c ₂	c ₃	c ₄	c ₅	c ₆	c ₇	c ₈
flag	-	0	1	1	1	1	1	1	0

Table 7.52: SYNC_HIGH_DYNAMIC_a (SHA): High dynamic variable part. Occupies one slot

Description	Octet	Bit number							
		8	7	6	5	4	3	2	1
flag	-	0	1	1	1	1	1	1	0
s, ver, rid, a/d	1	s ₂₇	s ₂₆	s ₂₅	0	0	0	1	0
s	2	s ₂₄	s ₂₃	s ₂₂	s ₂₁	s ₂₀	s ₁₉	s ₁₈	s ₁₇
s	3	s ₁₆	s ₁₅	s ₁₄	s ₁₃	s ₁₂	s ₁₁	s ₁₀	s ₉
s	4	s ₈	s ₇	s ₆	s ₅	s ₄	s ₃	s ₂	s ₁
nic, cprf, b/g, tqc	5	nic ₄	nic ₃	nic ₂	nic ₁	cprf	b/g	1	0
lat	6	lat ₈	lat ₇	lat ₆	lat ₅	lat ₄	lat ₃	lat ₂	lat ₁
balt	7	balt ₁₂	balt ₁₁	balt ₁₀	balt ₉	lat ₁₂	lat ₁₁	lat ₁₀	lat ₉
balt	8	balt ₈	balt ₇	balt ₆	balt ₅	balt ₄	balt ₃	balt ₂	balt ₁
lon	9	lon ₈	lon ₇	lon ₆	lon ₅	lon ₄	lon ₃	lon ₂	lon ₁
tfom, lon	10	tfom ₂	tfom ₁	lon ₁₄	lon ₁₃	lon ₁₂	lon ₁₁	lon ₁₀	lon ₉
da, id	11	da ₄	da ₃	da ₂	da ₁	0	0	0	1
br/gr, bgo	12	br/gr	bgo ₇	bgo ₆	bgo ₅	bgo ₄	bgo ₃	bgo ₂	bgo ₁
altr	13	altr ₈	altr ₇	altr ₆	altr ₅	altr ₄	altr ₃	altr ₂	altr ₁
altr, sil, gs	14	altr ₉	res ₃	sil ₂	sil ₁	gs ₁₂	gs ₁₁	gs ₁₀	gs ₉
gs	15	gs ₈	gs ₇	gs ₆	gs ₅	gs ₄	gs ₃	gs ₂	gs ₁
lon4,lat4	16	lon ₄₄	lon ₄₃	lon ₄₂	lon ₄₁	lat ₄₄	lat ₄₃	lat ₄₂	lat ₄₁
gt	17	gt ₈	gt ₇	gt ₆	gt ₅	gt ₄	gt ₃	gt ₂	gt ₁
gt,pt	18	gt ₁₂	gt ₁₁	gt ₁₀	gt ₉	res	res	pt ₂	pt ₁
po	19	po ₈	po ₇	po ₆	po ₅	po ₄	po ₃	po ₂	po ₁
c	20	c ₉	c ₁₀	c ₁₁	c ₁₂	c ₁₃	c ₁₄	c ₁₅	c ₁₆
c	21	c ₁	c ₂	c ₃	c ₄	c ₅	c ₆	c ₇	c ₈
flag	-	0	1	1	1	1	1	1	0

Table 7.53: SYNC_FULL_POSITION_a (SPa): Full Position variable part. Occupies one slot

Description	Octet	Bit number							
		8	7	6	5	4	3	2	1
flag	-	0	1	1	1	1	1	1	0
s, ver, rid, a/d	1	s ₂₇	s ₂₆	s ₂₅	0	0	0	1	0
s	2	s ₂₄	s ₂₃	s ₂₂	s ₂₁	s ₂₀	s ₁₉	s ₁₈	s ₁₇
s	3	s ₁₆	s ₁₅	s ₁₄	s ₁₃	s ₁₂	s ₁₁	s ₁₀	s ₉
s	4	s ₈	s ₇	s ₆	s ₅	s ₄	s ₃	s ₂	s ₁
nic, cprf, b/g, tqc	5	nic ₄	nic ₃	nic ₂	nic ₁	cprf	b/g	1	0
lat	6	lat ₈	lat ₇	lat ₆	lat ₅	lat ₄	lat ₃	lat ₂	lat ₁
balt	7	balt ₁₂	balt ₁₁	balt ₁₀	balt ₉	lat ₁₂	lat ₁₁	lat ₁₀	lat ₉
balt	8	balt ₈	balt ₇	balt ₆	balt ₅	balt ₄	balt ₃	balt ₂	balt ₁
lon	9	lon ₈	lon ₇	lon ₆	lon ₅	lon ₄	lon ₃	lon ₂	lon ₁
tfom, lon	10	tfom ₂	tfom ₁	lon ₁₄	lon ₁₃	lon ₁₂	lon ₁₁	lon ₁₀	lon ₉
da, id	11	da ₄	da ₃	da ₂	da ₁	0	0	1	0
pid, lat6	12	pid ₁₀	pid ₉	lat ₆	lat ₅	lat ₄	lat ₃	lat ₂	lat ₁
pid	13	pid ₈	pid ₇	pid ₆	pid ₅	pid ₄	pid ₃	pid ₂	pid ₁
gt, bgo	14	gt ₁₁	bgo ₇	bgo ₆	bgo ₅	bgo ₄	bgo ₃	bgo ₂	bgo ₁
gt, lon6	15	gt ₁₀	gt ₉	lon ₆	lon ₅	lon ₄	lon ₃	lon ₂	lon ₁
gt	16	gt ₈	gt ₇	gt ₆	gt ₅	gt ₄	gt ₃	gt ₂	gt ₁
gs	17	gs ₈	gs ₇	gs ₆	gs ₅	gs ₄	gs ₃	gs ₂	gs ₁
gs, sil, pt	18	gs ₁₁	gs ₁₀	gs ₉	res ₃	sil ₂	sil ₁	pt ₂	pt ₁
po	19	po ₈	po ₇	po ₆	po ₅	po ₄	po ₃	po ₂	po ₁
c	20	c ₉	c ₁₀	c ₁₁	c ₁₂	c ₁₃	c ₁₄	c ₁₅	c ₁₆
c	21	c ₁	c ₂	c ₃	c ₄	c ₅	c ₆	c ₇	c ₈
flag	-	0	1	1	1	1	1	1	0

Table 7.54: SYNC_BASIC_GROUND_a (BGa): Basic Ground variable part. Occupies one slot

Description	Octet	Bit number							
		8	7	6	5	4	3	2	1
flag	-	0	1	1	1	1	1	1	0
s, ver, rid, a/d	1	s ₂₇	s ₂₆	s ₂₅	0	0	0	1	0
s	2	s ₂₄	s ₂₃	s ₂₂	s ₂₁	s ₂₀	s ₁₉	s ₁₈	s ₁₇
s	3	s ₁₆	s ₁₅	s ₁₄	s ₁₃	s ₁₂	s ₁₁	s ₁₀	s ₉
s	4	s ₈	s ₇	s ₆	s ₅	s ₄	s ₃	s ₂	s ₁
nic, cprf, b/g, tqc	5	nic ₄	nic ₃	nic ₂	nic ₁	cprf	b/g	1	0
lat	6	lat ₈	lat ₇	lat ₆	lat ₅	lat ₄	lat ₃	lat ₂	lat ₁
balt	7	balt ₁₂	balt ₁₁	balt ₁₀	balt ₉	lat ₁₂	lat ₁₁	lat ₁₀	lat ₉
balt	8	balt ₈	balt ₇	balt ₆	balt ₅	balt ₄	balt ₃	balt ₂	balt ₁
lon	9	lon ₈	lon ₇	lon ₆	lon ₅	lon ₄	lon ₃	lon ₂	lon ₁
tfom, lon	10	tfom ₂	tfom ₁	lon ₁₄	lon ₁₃	lon ₁₂	lon ₁₁	lon ₁₀	lon ₉
da, id	11	da ₄	da ₃	da ₂	da ₁	0	0	1	1
h	12	res	res	res	h ₅	h ₄	h ₃	h ₂	h ₁
pid, min	13	pid ₁₀	pid ₉	min ₆	min ₅	min ₄	min ₃	min ₂	min ₁
pid	14	pid ₈	pid ₇	pid ₆	pid ₅	pid ₄	pid ₃	pid ₂	pid ₁
bgo	15	res	bgo ₇	bgo ₆	bgo ₅	bgo ₄	bgo ₃	bgo ₂	bgo ₁
slt	16	slt ₈	slt ₇	slt ₆	slt ₅	slt ₄	slt ₃	slt ₂	slt ₁
lon4, lat4	17	lon ₄ ₄	lon ₄ ₃	lon ₄ ₂	lon ₄ ₁	lat ₄ ₄	lat ₄ ₃	lat ₄ ₂	lat ₄ ₁
sec, pt	18	sec ₆	sec ₅	sec ₄	sec ₃	sec ₂	sec ₁	pt ₂	pt ₁
po	19	po ₈	po ₇	po ₆	po ₅	po ₄	po ₃	po ₂	po ₁
c	20	c ₉	c ₁₀	c ₁₁	c ₁₂	c ₁₃	c ₁₄	c ₁₅	c ₁₆
c	21	c ₁	c ₂	c ₃	c ₄	c ₅	c ₆	c ₇	c ₈
flag	-	0	1	1	1	1	1	1	0

Table 7.55: SYNC.UTC.TIME_a (UTCa): UTC Time variable part. Occupies one slot

Description	Octet	Bit number							
		8	7	6	5	4	3	2	1
flag	-	0	1	1	1	1	1	1	0
s, ver, rid, a/d	1	s ₂₇	s ₂₆	s ₂₅	0	0	0	1	0
s	2	s ₂₄	s ₂₃	s ₂₂	s ₂₁	s ₂₀	s ₁₉	s ₁₈	s ₁₇
s	3	s ₁₆	s ₁₅	s ₁₄	s ₁₃	s ₁₂	s ₁₁	s ₁₀	s ₉
s	4	s ₈	s ₇	s ₆	s ₅	s ₄	s ₃	s ₂	s ₁
nic, cprf, b/g, tqc	5	nic ₄	nic ₃	nic ₂	nic ₁	cprf	b/g	1	0
lat	6	lat ₈	lat ₇	lat ₆	lat ₅	lat ₄	lat ₃	lat ₂	lat ₁
balt	7	balt ₁₂	balt ₁₁	balt ₁₀	balt ₉	lat ₁₂	lat ₁₁	lat ₁₀	lat ₉
balt	8	balt ₈	balt ₇	balt ₆	balt ₅	balt ₄	balt ₃	balt ₂	balt ₁
lon	9	lon ₈	lon ₇	lon ₆	lon ₅	lon ₄	lon ₃	lon ₂	lon ₁
tfom, lon	10	tfom ₂	tfom ₁	lon ₁₄	lon ₁₃	lon ₁₂	lon ₁₁	lon ₁₀	lon ₉
da, id	11	da ₄	da ₃	da ₂	da ₁	0	1	0	0
day	12	res	res	res	day ₅	day ₄	day ₃	day ₂	day ₁
yr	13	yr ₈	yr ₇	yr ₆	yr ₅	yr ₄	yr ₃	yr ₂	yr ₁
h, mon	14	h ₄	h ₃	h ₂	h ₁	mon ₄	mon ₃	mon ₂	mon ₁
h, min	15	res	h ₅	min ₆	min ₅	min ₄	min ₃	min ₂	min ₁
slt	16	slt ₈	slt ₇	slt ₆	slt ₅	slt ₄	slt ₃	slt ₂	slt ₁
lon4, lat4	17	lon ₄₄	lon ₄₃	lon ₄₂	lon ₄₁	lat ₄₄	lat ₄₃	lat ₄₂	lat ₄₁
sec, pt	18	sec ₆	sec ₅	sec ₄	sec ₃	sec ₂	sec ₁	pt ₂	pt ₁
po	19	po ₈	po ₇	po ₆	po ₅	po ₄	po ₃	po ₂	po ₁
c	20	c ₉	c ₁₀	c ₁₁	c ₁₂	c ₁₃	c ₁₄	c ₁₅	c ₁₆
c	21	c ₁	c ₂	c ₃	c ₄	c ₅	c ₆	c ₇	c ₈
flag	-	0	1	1	1	1	1	1	0

Table 7.56: SYNC_TWO_SLOT_TCP/SVQ_a (STa): Two-slot TCP variable part. Occupies two slots

Description	Octet	Bit number							
		8	7	6	5	4	3	2	1
flag	-	0	1	1	1	1	1	1	0
s, ver, rid, a/d	1	s ₂₇	s ₂₆	s ₂₅	0	0	0	1	0
s	2	s ₂₄	s ₂₃	s ₂₂	s ₂₁	s ₂₀	s ₁₉	s ₁₈	s ₁₇
s	3	s ₁₆	s ₁₅	s ₁₄	s ₁₃	s ₁₂	s ₁₁	s ₁₀	s ₉
s	4	s ₈	s ₇	s ₆	s ₅	s ₄	s ₃	s ₂	s ₁
nic, cprf, b/g, tqc	5	nic ₄	nic ₃	nic ₂	nic ₁	cprf	b/g	1	0
lat	6	lat ₈	lat ₇	lat ₆	lat ₅	lat ₄	lat ₃	lat ₂	lat ₁
balt	7	balt ₁₂	balt ₁₁	balt ₁₀	balt ₉	lat ₁₂	lat ₁₁	lat ₁₀	lat ₉
balt	8	balt ₈	balt ₇	balt ₆	balt ₅	balt ₄	balt ₃	balt ₂	balt ₁
lon	9	lon ₈	lon ₇	lon ₆	lon ₅	lon ₄	lon ₃	lon ₂	lon ₁
tfom, lon	10	tfom ₂	tfom ₁	lon ₁₄	lon ₁₃	lon ₁₂	lon ₁₁	lon ₁₀	lon ₉
da, id	11	da ₄	da ₃	da ₂	da ₁	1	0	0	0
lat	12	lat ₈	lat ₇	lat ₆	lat ₅	lat ₄	lat ₃	lat ₂	lat ₁
balt, lat	13	balt ₁₂	balt ₁₁	balt ₁₀	balt ₉	lat ₁₂	lat ₁₁	lat ₁₀	lat ₉
balt	14	balt ₈	balt ₇	balt ₆	balt ₅	balt ₄	balt ₃	balt ₂	balt ₁
lon	15	lon ₈	lon ₇	lon ₆	lon ₅	lon ₄	lon ₃	lon ₂	lon ₁
ttg, lon	16	ttg ₆	ttg ₅	lon ₁₄	lon ₁₃	lon ₁₂	lon ₁₁	lon ₁₀	lon ₉
ttg	17	ttg ₄	ttg ₃	ttg ₂	ttg ₁	res	res	res	res
lat	18	lat ₈	lat ₇	lat ₆	lat ₅	lat ₄	lat ₃	lat ₂	lat ₁
balt, lat	19	balt ₁₂	balt ₁₁	balt ₁₀	balt ₉	lat ₁₂	lat ₁₁	lat ₁₀	lat ₉
balt	20	balt ₈	balt ₇	balt ₆	balt ₅	balt ₄	balt ₃	balt ₂	balt ₁
lon	21	lon ₈	lon ₇	lon ₆	lon ₅	lon ₄	lon ₃	lon ₂	lon ₁
ttg, lon	22	ttg ₆	ttg ₅	lon ₁₄	lon ₁₃	lon ₁₂	lon ₁₁	lon ₁₀	lon ₉
ttg	23	ttg ₄	ttg ₃	ttg ₂	ttg ₁	res	res	res	res
lat	24	lat ₈	lat ₇	lat ₆	lat ₅	lat ₄	lat ₃	lat ₂	lat ₁
balt, lat	25	balt ₁₂	balt ₁₁	balt ₁₀	balt ₉	lat ₁₂	lat ₁₁	lat ₁₀	lat ₉
balt	26	balt ₈	balt ₇	balt ₆	balt ₅	balt ₄	balt ₃	balt ₂	balt ₁
lon	27	lon ₈	lon ₇	lon ₆	lon ₅	lon ₄	lon ₃	lon ₂	lon ₁
ttg, lon	28	ttg ₆	ttg ₅	lon ₁₄	lon ₁₃	lon ₁₂	lon ₁₁	lon ₁₀	lon ₉
ttg	29	ttg ₄	ttg ₃	ttg ₂	ttg ₁	res	res	res	res
lat	30	lat ₈	lat ₇	lat ₆	lat ₅	lat ₄	lat ₃	lat ₂	lat ₁
balt, lat	31	balt ₁₂	balt ₁₁	balt ₁₀	balt ₉	lat ₁₂	lat ₁₁	lat ₁₀	lat ₉
balt	32	balt ₈	balt ₇	balt ₆	balt ₅	balt ₄	balt ₃	balt ₂	balt ₁
lon	33	lon ₈	lon ₇	lon ₆	lon ₅	lon ₄	lon ₃	lon ₂	lon ₁
ttg, lon	34	ttg ₆	ttg ₅	lon ₁₄	lon ₁₃	lon ₁₂	lon ₁₁	lon ₁₀	lon ₉
ttg	35	ttg ₄	ttg ₃	ttg ₂	ttg ₁	res	res	res	res
csl	36	csl ₈	csl ₇	csl ₆	csl ₅	csl ₄	csl ₃	csl ₂	csl ₁
csl	37	csl ₁₆	csl ₁₅	csl ₁₄	csl ₁₃	csl ₁₂	csl ₁₁	csl ₁₀	csl ₉
st, csl	38	st ₃	st ₂	st ₁	csl ₂₁	csl ₂₀	csl ₁₉	csl ₁₈	csl ₁₇
csr	39	csr ₈	csr ₇	csr ₆	csr ₅	csr ₄	csr ₃	csr ₂	csr ₁
csr	40	csr ₁₆	csr ₁₅	csr ₁₄	csr ₁₃	csr ₁₂	csr ₁₁	csr ₁₀	csr ₉
nacv, csr	41	nacv ₃	nacv ₂	nacv ₁	csr ₂₁	csr ₂₀	csr ₁₉	csr ₁₈	csr ₁₇
nacp, cdti, nicb, acas, ra	42	nacp ₄	nacp ₃	nacp ₂	nacp ₁	cdti	nicb	acas	ra
pid	43	pid ₈	pid ₇	pid ₆	pid ₅	pid ₄	pid ₃	pid ₂	pid ₁
pid, lat6	44	pid ₁₀	pid ₉	lat ₆	lat ₆	lat ₆	lat ₆	lat ₆	lat ₆
altr, nucr, br/gr, lon6	45	altr ₉	br/gr	lon ₆	lon ₆	lon ₆	lon ₆	lon ₆	lon ₆
altr	46	altr ₈	altr ₇	altr ₆	altr ₅	altr ₄	altr ₃	altr ₂	altr ₁
sil, ac	47	res	sil ₂	sil ₁	ac ₅	ac ₄	ac ₃	ac ₂	ac ₁

Description	Octet	Bit number							
		8	7	6	5	4	3	2	1
gs	48	gs ₈	gs ₇	gs ₆	gs ₅	gs ₄	gs ₃	gs ₂	gs ₁
gs, gt	49	gs ₁₁	gs ₁₀	gs ₉	gt ₅	gt ₄	gt ₃	gt ₂	gt ₁
gt, pt	50	gt ₁₁	gt ₁₀	gt ₉	gt ₈	gt ₇	gt ₆	pt ₂	pt ₁
po	51	po ₈	po ₇	po ₆	po ₅	po ₄	po ₃	po ₂	po ₁
c	52	c ₉	c ₁₀	c ₁₁	c ₁₂	c ₁₃	c ₁₄	c ₁₅	c ₁₆
c	53	c ₁	c ₂	c ₃	c ₄	c ₅	c ₆	c ₇	c ₈
flag	-	0	1	1	1	1	1	1	0

Table 7.57: SYNC_SINGLE_SLOT_TCP_a (SSa): Single Slot TCP variable part. Occupies one slot

Description	Octet	Bit number							
		8	7	6	5	4	3	2	1
flag	-	0	1	1	1	1	1	1	0
s, ver, rid, a/d	1	s ₂₇	s ₂₆	s ₂₅	0	0	0	1	0
s	2	s ₂₄	s ₂₃	s ₂₂	s ₂₁	s ₂₀	s ₁₉	s ₁₈	s ₁₇
s	3	s ₁₆	s ₁₅	s ₁₄	s ₁₃	s ₁₂	s ₁₁	s ₁₀	s ₉
s	4	s ₈	s ₇	s ₆	s ₅	s ₄	s ₃	s ₂	s ₁
nic, cprf, b/g, tqc	5	nic ₄	nic ₃	nic ₂	nic ₁	cprf	b/g	1	0
lat	6	lat ₈	lat ₇	lat ₆	lat ₅	lat ₄	lat ₃	lat ₂	lat ₁
balt	7	balt ₁₂	balt ₁₁	balt ₁₀	balt ₉	lat ₁₂	lat ₁₁	lat ₁₀	lat ₉
balt	8	balt ₈	balt ₇	balt ₆	balt ₅	balt ₄	balt ₃	balt ₂	balt ₁
lon	9	lon ₈	lon ₇	lon ₆	lon ₅	lon ₄	lon ₃	lon ₂	lon ₁
tfom, lon	10	tfom ₂	tfom ₁	lon ₁₄	lon ₁₃	lon ₁₂	lon ₁₁	lon ₁₀	lon ₉
da, id	11	da ₄	da ₃	da ₂	da ₁	1	0	0	1
balt	12	balt ₈	balt ₇	balt ₆	balt ₅	balt ₄	balt ₃	balt ₂	balt ₁
balt, no, pid	13	balt ₁₂	balt ₁₁	balt ₁₀	no ₂	no ₁	pid ₃	pid ₂	pid ₁
pid	14	pid ₈	pid ₇	pid ₆	pid ₅	pid ₄	pid ₃	pid ₂	pid ₁
lat	15	lat ₈	lat ₇	lat ₆	lat ₅	lat ₄	lat ₃	lat ₂	lat ₁
lat, lon	16	lat ₁₂	lat ₁₁	lat ₁₀	lat ₉	lon ₁₄	lon ₁₃	lon ₁₂	lon ₁₁
lon	17	lon ₁₀	lon ₉	lon ₈	lon ₇	lon ₆	lon ₅	lon ₄	lon ₃
ttg, pt	18	ttg ₆	ttg ₅	ttg ₄	ttg ₃	ttg ₂	ttg ₁	pt ₂	pt ₁
po	19	po ₈	po ₇	po ₆	po ₅	po ₄	po ₃	po ₂	po ₁
c	20	c ₉	c ₁₀	c ₁₁	c ₁₂	c ₁₃	c ₁₄	c ₁₅	c ₁₆
c	21	c ₁	c ₂	c ₃	c ₄	c ₅	c ₆	c ₇	c ₈
flag	-	0	1	1	1	1	1	1	0

Table 7.58: SYNC_SINGLE_SLOT_SVQ_a (SVa): Single Slot SVQ variable part. Occupies one slot

Description	Octet	Bit number							
		8	7	6	5	4	3	2	1
flag	-	0	1	1	1	1	1	1	0
s, ver, rid, a/d	1	s ₂₇	s ₂₆	s ₂₅	0	0	0	1	0
s	2	s ₂₄	s ₂₃	s ₂₂	s ₂₁	s ₂₀	s ₁₉	s ₁₈	s ₁₇
s	3	s ₁₆	s ₁₅	s ₁₄	s ₁₃	s ₁₂	s ₁₁	s ₁₀	s ₉
s	4	s ₈	s ₇	s ₆	s ₅	s ₄	s ₃	s ₂	s ₁
nic, cprf, b/g, tqc	5	nic ₄	nic ₃	nic ₂	nic ₁	cprf	b/g	1	0
lat	6	lat ₈	lat ₇	lat ₆	lat ₅	lat ₄	lat ₃	lat ₂	lat ₁
balt	7	balt ₁₂	balt ₁₁	balt ₁₀	balt ₉	lat ₁₂	lat ₁₁	lat ₁₀	lat ₉
balt	8	balt ₈	balt ₇	balt ₆	balt ₅	balt ₄	balt ₃	balt ₂	balt ₁
lon	9	lon ₈	lon ₇	lon ₆	lon ₅	lon ₄	lon ₃	lon ₂	lon ₁
tfom, lon	10	tfom ₂	tfom ₁	lon ₁₄	lon ₁₃	lon ₁₂	lon ₁₁	lon ₁₀	lon ₉
da, id	11	da ₄	da ₃	da ₂	da ₁	0	1	0	1
nacp	12	0	0	0	1	nacp ₄	nacp ₃	nacp ₂	nacp ₁
nacv, sil, nicb, acas, ra	13	nacv ₃	nacv ₂	nacv ₁	sil ₂	sil ₁	nicb	acas	ra
st, ac	14	st ₃	st ₂	st ₁	ac ₅	ac ₄	ac ₃	ac ₂	ac ₁
res	15	0	0	0	0	0	0	0	0
res	16	0	0	0	0	0	0	0	0
res	17	0	0	0	0	0	0	0	0
res, pt	18	0	0	0	0	0	0	pt ₂	pt ₁
po	19	po ₈	po ₇	po ₆	po ₅	po ₄	po ₃	po ₂	po ₁
c	20	c ₉	c ₁₀	c ₁₁	c ₁₂	c ₁₃	c ₁₄	c ₁₅	c ₁₆
c	21	c ₁	c ₂	c ₃	c ₄	c ₅	c ₆	c ₇	c ₈
flag	-	0	1	1	1	1	1	1	0

Table 7.59: SYNC_AIRCRAFT_DATA_a (SDa): Aircraft data variable part. Occupies one slot

Description	Octet	Bit number							
		8	7	6	5	4	3	2	1
flag	-	0	1	1	1	1	1	1	0
s, ver, rid, a/d	1	s ₂₇	s ₂₆	s ₂₅	0	0	0	1	0
s	2	s ₂₄	s ₂₃	s ₂₂	s ₂₁	s ₂₀	s ₁₉	s ₁₈	s ₁₇
s	3	s ₁₆	s ₁₅	s ₁₄	s ₁₃	s ₁₂	s ₁₁	s ₁₀	s ₉
s	4	s ₈	s ₇	s ₆	s ₅	s ₄	s ₃	s ₂	s ₁
nic, cprf, b/g, tqc	5	nic ₄	nic ₃	nic ₂	nic ₁	cprf	b/g	1	0
lat	6	lat ₈	lat ₇	lat ₆	lat ₅	lat ₄	lat ₃	lat ₂	lat ₁
balt	7	balt ₁₂	balt ₁₁	balt ₁₀	balt ₉	lat ₁₂	lat ₁₁	lat ₁₀	lat ₉
balt	8	balt ₈	balt ₇	balt ₆	balt ₅	balt ₄	balt ₃	balt ₂	balt ₁
lon	9	lon ₈	lon ₇	lon ₆	lon ₅	lon ₄	lon ₃	lon ₂	lon ₁
tfom, lon	10	tfom ₂	tfom ₁	lon ₁₄	lon ₁₃	lon ₁₂	lon ₁₁	lon ₁₀	lon ₉
da, id	11	da ₄	da ₃	da ₂	da ₁	1	0	1	0
ac	12	0	0	0	1	ac ₄	ac ₃	ac ₂	ac ₁
ac, st, csl	13	ac ₅	st ₃	st ₂	st ₁	csl ₁₂	csl ₁₁	csl ₁₀	csl ₉
csl	14	csl ₈	csl ₇	csl ₆	csl ₅	csl ₄	csl ₃	csl ₂	csl ₁
csl	15	csl ₂₀	csl ₁₉	csl ₁₈	csl ₁₇	csl ₁₆	csl ₁₅	csl ₁₄	csl ₁₃
csl, csr	16	csl ₂₁	csr ₇	csr ₆	csr ₅	csr ₄	csr ₃	csr ₂	csr ₁
csr	17	csr ₁₅	csr ₁₄	csr ₁₃	csr ₁₂	csr ₁₁	csr ₁₀	csr ₉	csr ₈
csr, pt	18	csr ₂₁	csr ₂₀	csr ₁₉	csr ₁₈	csr ₁₇	csr ₁₆	pt ₂	pt ₁
po	19	po ₈	po ₇	po ₆	po ₅	po ₄	po ₃	po ₂	po ₁
c	20	c ₉	c ₁₀	c ₁₁	c ₁₂	c ₁₃	c ₁₄	c ₁₅	c ₁₆
c	21	c ₁	c ₂	c ₃	c ₄	c ₅	c ₆	c ₇	c ₈
flag	-	0	1	1	1	1	1	1	0

Table 7.60: SYNC_HIGH_RESOLUTION_a (SRa): High resolution variable part. Occupies one slot

Description	Octet	Bit number							
		8	7	6	5	4	3	2	1
flag	-	0	1	1	1	1	1	1	0
s, ver, rid, a/d	1	s ₂₇	s ₂₆	s ₂₅	0	0	0	1	0
s	2	s ₂₄	s ₂₃	s ₂₂	s ₂₁	s ₂₀	s ₁₉	s ₁₈	s ₁₇
s	3	s ₁₆	s ₁₅	s ₁₄	s ₁₃	s ₁₂	s ₁₁	s ₁₀	s ₉
s	4	s ₈	s ₇	s ₆	s ₅	s ₄	s ₃	s ₂	s ₁
nic, cprf, b/g, tqc	5	nic ₄	nic ₃	nic ₂	nic ₁	cprf	b/g	1	0
lat	6	lat ₈	lat ₇	lat ₆	lat ₅	lat ₄	lat ₃	lat ₂	lat ₁
balt	7	balt ₁₂	balt ₁₁	balt ₁₀	balt ₉	lat ₁₂	lat ₁₁	lat ₁₀	lat ₉
balt	8	balt ₈	balt ₇	balt ₆	balt ₅	balt ₄	balt ₃	balt ₂	balt ₁
lon	9	lon ₈	lon ₇	lon ₆	lon ₅	lon ₄	lon ₃	lon ₂	lon ₁
tfom, lon	10	tfom ₂	tfom ₁	lon ₁₄	lon ₁₃	lon ₁₂	lon ₁₁	lon ₁₀	lon ₉
da, id	11	da ₄	da ₃	da ₂	da ₁	1	0	1	0
id	12	1	0	1	0	0	0	0	0
nucr, gs	13	res	nucr ₃	nucr ₂	nucr ₁	gs ₁₂	gs ₁₁	gs ₁₀	gs ₉
gs	14	gs ₈	gs ₇	gs ₆	gs ₅	gs ₄	gs ₃	gs ₂	gs ₁
lon8	15	lon8 ₈	lon8 ₇	lon8 ₆	lon8 ₅	lon8 ₄	lon8 ₃	lon8 ₂	lon8 ₁
lat8	16	lat8 ₈	lat8 ₇	lat8 ₆	lat8 ₅	lat8 ₄	lat8 ₃	lat8 ₂	lat8 ₁
gt	17	gt ₈	gt ₇	gt ₆	gt ₅	gt ₄	gt ₃	gt ₂	gt ₁
gt, tind, pt	18	gt ₁₂	gt ₁₁	gt ₁₀	gt ₉	tind ₂	tind ₁	pt ₂	pt ₁
po	19	po ₈	po ₇	po ₆	po ₅	po ₄	po ₃	po ₂	po ₁
c	20	c ₉	c ₁₀	c ₁₁	c ₁₂	c ₁₃	c ₁₄	c ₁₅	c ₁₆
c	21	c ₁	c ₂	c ₃	c ₄	c ₅	c ₆	c ₇	c ₈
flag	-	0	1	1	1	1	1	1	0

Table 7.61: CTRL_DOS_a (CDa): Directory of Service(DOS) message. Fits within one slot

Description	Octet	Bit number							
		8	7	6	5	4	3	2	1
flag	-	0	1	1	1	1	1	1	0
s, ver, rid, a/d	1	s ₂₇	s ₂₆	s ₂₅	0	0	0	1	1
s	2	s ₂₄	s ₂₃	s ₂₂	s ₂₁	s ₂₀	s ₁₉	s ₁₈	s ₁₇
s	3	s ₁₆	s ₁₅	s ₁₄	s ₁₃	s ₁₂	s ₁₁	s ₁₀	s ₉
s	4	s ₈	s ₇	s ₆	s ₅	s ₄	s ₃	s ₂	s ₁
res, mi	5	0	0	1	1	0	0	0	1
ucid, UCTRL DLPDU	6	0	0	0	1	0	1	0	0
CTRL parameter ID	7	1	1	0	0	0	1	1	0
n	8	n ₈	n ₇	n ₆	n ₅	n ₄	n ₃	n ₂	n ₁
gsc, ai	9	gsc	1	1	1	ent ₄	ent ₃	ent ₂	ent ₁
si	10	si ₈	si ₇	si ₆	si ₅	si ₄	si ₃	si ₂	si ₁
res, anum	11	0	0	0	0	0	0	0	1
a	12	a ₈	a ₇	a ₆	a ₅	a ₄	a ₃	a ₂	a ₁
gsc, ai, f	13	gsc	1	1	1	f ₁₂	f ₁₁	f ₁₀	f ₉
f	14	f ₈	f ₇	f ₆	f ₅	f ₄	f ₃	f ₂	f ₁
si	15	si ₈	si ₇	si ₆	si ₅	si ₄	si ₃	si ₂	si ₁
res, anum	16	0	0	0	0	0	0	0	1
a	17	a ₈	a ₇	a ₆	a ₅	a ₄	a ₃	a ₂	a ₁
sit, null reservation	18	sit ₆	sit ₅	sit ₄	sit ₃	sit ₂	sit ₁	0	0
null reservation	19	0	0	0	0	0	0	0	0
c	20	c ₉	c ₁₀	c ₁₁	c ₁₂	c ₁₃	c ₁₄	c ₁₅	c ₁₆
c	21	c ₁	c ₂	c ₃	c ₄	c ₅	c ₆	c ₇	c ₈
flag	-	0	1	1	1	1	1	1	0

7.4.3.1.5.2

Bursts defined for TIS-B tests

Table 7.62: TIS_MAN_a (TMA): Management message with response reservation

Description	Octet	Bit number							
		8	7	6	5	4	3	2	1
flag	-	0	1	1	1	1	1	1	0
s, ver, rid, a/d	1	s ₂₇	s ₂₆	s ₂₅	0	0	0	0	1
s	2	s ₂₄	s ₂₃	s ₂₂	s ₂₁	s ₂₀	s ₁₉	s ₁₈	s ₁₇
s	3	s ₁₆	s ₁₅	s ₁₄	s ₁₃	s ₁₂	s ₁₁	s ₁₀	s ₉
s	4	s ₈	s ₇	s ₆	s ₅	s ₄	s ₃	s ₂	s ₁
udid, ucd	5	0	0	0	0	0	1	1	1
TIS-B message ID (tmi) version number (vers)	6	vers ₄	vers ₃	vers ₂	vers ₁	tmi ₄	tmi ₃	tmi ₂	tmi ₁
TIV ID (tivid) update period (up)	7	up ₅	up ₄	up ₃	up ₂	up ₁	tivid ₃	tivid ₂	tivid ₁
TIV status (tivs) TIS-B target resolution (tacc)	8	lat ₁	tacc ₄	tacc ₃	tacc ₂	tacc ₁	tivs ₂	tivs ₁	up ₆
reference point latitude (lat)	9	lat ₉	lat ₈	lat ₇	lat ₆	lat ₅	lat ₄	lat ₃	lat ₂
reference point longitude (long)	10	long ₃	long ₂	long ₁	lat ₁₄	lat ₁₃	lat ₁₂	lat ₁₁	lat ₁₀
	11	long ₁₁	long ₁₀	long ₉	long ₈	long ₇	long ₆	long ₅	long ₄
lower barometric altitude (lbar)	12	lbar ₄	lbar ₃	lbar ₂	lbar ₁	long ₁₅	long ₁₄	long ₁₃	long ₁₂
upper barometric altitude (ubar)	13	ubar ₄	ubar ₃	ubar ₂	ubar ₁	lbar ₈	lbar ₇	lbar ₆	lbar ₅
number of vertices (nvert)	14	nvert ₄	nvert ₃	nvert ₂	nvert ₁	ubar ₈	ubar ₇	ubar ₆	ubar ₅
vertex latitude (vlat(1-k))	15	vlat ₁₈	vlat ₁₇	vlat ₁₆	vlat ₁₅	vlat ₁₄	vlat ₁₃	vlat ₁₂	vlat ₁₁
vertex longitude (vlg(1 -k))	16	vlg ₁₈	vlg ₁₇	vlg ₁₆	vlg ₁₅	vlg ₁₄	vlg ₁₃	vlg ₁₂	vlg ₁₁
								
	m-4	vlatk ₈	vlatk ₇	vlatk ₆	vlatk ₅	vlatk ₄	vlatk ₃	vlatk ₂	vlatk ₁
	m-3	vlgk ₈	vlgk ₇	vlgk ₆	vlgk ₅	vlgk ₄	vlgk ₃	vlgk ₂	vlgk ₁
response reservation	m-2	0	0	0	0	0	1	1	1
c	m-1	c ₉	c ₁₀	c ₁₁	c ₁₂	c ₁₃	c ₁₄	c ₁₅	c ₁₆
c	m	c ₁	c ₂	c ₃	c ₄	c ₅	c ₆	c ₇	c ₈
flag	-	0	1	1	1	1	1	1	0

Table 7.63: TIS_AC_AIR_a (TAa): Aircraft target message (airborne TIV) with response reservation

Description	Octet	Bit number							
		8	7	6	5	4	3	2	1
flag	-	0	1	1	1	1	1	1	0
s, ver, rid, a/d	1	s ₂₇	s ₂₆	s ₂₅	0	0	0	0	1
s	2	s ₂₄	s ₂₃	s ₂₂	s ₂₁	s ₂₀	s ₁₉	s ₁₈	s ₁₇
s	3	s ₁₆	s ₁₅	s ₁₄	s ₁₃	s ₁₂	s ₁₁	s ₁₀	s ₉
s	4	s ₈	s ₇	s ₆	s ₅	s ₄	s ₃	s ₂	s ₁
udid, ucd	5	0	0	0	0	0	1	1	1
TIS-B message ID (tmi) TIV ID (tivid) target identifier flag (tflg)	6	tflg	tivid ₃	tivid ₂	tivid ₁	tmi ₄	tmi ₃	tmi ₂	tmi ₁
radar/fusion flag (rflg) ADS-B fault flag (adsff) flight ID flag (fidflg) target identifier (tid)	7	tid ₅	tid ₄	tid ₃	tid ₂	tid ₁	fidflg	adsff	rflg
	8	tid ₁₃	tid ₁₂	tid ₁₁	tid ₁₀	tid ₉	tid ₈	tid ₇	tid ₆
	9	tid ₂₁	tid ₂₀	tid ₁₉	tid ₁₈	tid ₁₇	tid ₁₆	tid ₁₅	tid ₁₄
latitude (rlat)	10	rlat ₅	rlat ₄	rlat ₃	rlat ₂	rlat ₁	tid ₂₄	tid ₂₃	tid ₂₂
	11	rlat ₁₃	rlat ₁₂	rlat ₁₁	rlat ₁₀	rlat ₉	rlat ₈	rlat ₇	rlat ₆
longitude (rlg)	12	rlg ₅	rlg ₄	rlg ₃	rlg ₂	rlg ₁	rlat ₁₆	rlat ₁₅	rlat ₁₄
	13	rlg ₁₃	rlg ₁₂	rlg ₁₁	rlg ₁₀	rlg ₉	rlg ₈	rlg ₇	rlg ₆
ground track (gtk)	14	gtk ₅	gtk ₄	gtk ₃	gtk ₂	gtk ₁	rlg ₁₆	rlg ₁₅	rlg ₁₄
barometric altitude (bar)	15	bar ₅	bar ₄	bar ₃	bar ₂	bar ₁	gtk ₈	gtk ₇	gtk ₆
ground speed (gsp)	16	gsp ₁	bar ₁₂	bar ₁₁	bar ₁₀	bar ₉	bar ₈	bar ₇	bar ₆
	17	gsp ₉	gsp ₈	gsp ₇	gsp ₆	gsp ₅	gsp ₄	gsp ₃	gsp ₂
time stamp (tag)	18	tag ₆	tag ₅	tag ₄	tag ₃	tag ₂	tag ₁	gsp ₁₁	gsp ₁₀
flight ID type (fidty)	19	call ₇	call ₆	call ₅	call ₄	call ₃	call ₂	call ₁	fidty
callsign (call)(example)	20	call ₁₅	call ₁₄	call ₁₃	call ₁₂	call ₁₁	call ₁₀	call ₉	call ₈
	21	call ₂₃	call ₂₂	call ₂₁	call ₂₀	call ₁₉	call ₁₈	call ₁₇	call ₁₆
	22	call ₃₁	call ₃₀	call ₂₉	call ₂₈	call ₂₇	call ₂₆	call ₂₅	call ₂₄
	23	call ₃₉	call ₃₈	call ₃₇	call ₃₆	call ₃₅	call ₃₄	call ₃₃	call ₃₂
aircraft category (cat)	24	cat ₅	cat ₄	cat ₃	cat ₂	cat ₁	call ₄₂	call ₄₁	call ₄₀
response reservation	25	0	0	0	0	0	1	1	1
c	26	c ₉	c ₁₀	c ₁₁	c ₁₂	c ₁₃	c ₁₄	c ₁₅	c ₁₆
c	27	c ₁	c ₂	c ₃	c ₄	c ₅	c ₆	c ₇	c ₈
flag	-	0	1	1	1	1	1	1	0

Table 7.64: TIS_AC_GRD_a (TGa): Aircraft target message (ground TIV) with response reservation

Description	Octet	Bit number							
		8	7	6	5	4	3	2	1
flag	-	0	1	1	1	1	1	1	0
s, ver, rid, a/d	1	s ₂₇	s ₂₆	s ₂₅	0	0	0	0	1
s	2	s ₂₄	s ₂₃	s ₂₂	s ₂₁	s ₂₀	s ₁₉	s ₁₈	s ₁₇
s	3	s ₁₆	s ₁₅	s ₁₄	s ₁₃	s ₁₂	s ₁₁	s ₁₀	s ₉
s	4	s ₈	s ₇	s ₆	s ₅	s ₄	s ₃	s ₂	s ₁
udid, ucd	5	0	0	0	0	0	1	1	1
TIS-B message ID (tmi) TIV ID (tivid) target identifier flag (tflg)	6	tflg	tivid ₃	tivid ₂	tivid ₁	tmi ₄	tmi ₃	tmi ₂	tmi ₁
radar/fusion flag (rflg) ADS-B fault flag (adsff) flight ID flag (fidflg) target identifier (tid)	7	tid ₅	tid ₄	tid ₃	tid ₂	tid ₁	fidflg	adsff	rflg
	8	tid ₁₃	tid ₁₂	tid ₁₁	tid ₁₀	tid ₉	tid ₈	tid ₇	tid ₆
	9	tid ₂₁	tid ₂₀	tid ₁₉	tid ₁₈	tid ₁₇	tid ₁₆	tid ₁₅	tid ₁₄
latitude (rlat)	10	rlat ₅	rlat ₄	rlat ₃	rlat ₂	rlat ₁	tid ₂₄	tid ₂₃	tid ₂₂
	11	rlat ₁₃	rlat ₁₂	rlat ₁₁	rlat ₁₀	rlat ₉	rlat ₈	rlat ₇	rlat ₆
longitude (rlg)	12	rlg ₁	rlg ₂₀	rlg ₁₉	rlg ₁₈	rlg ₁₇	rlg ₁₆	rlg ₁₅	rlg ₁₄
	13	rlg ₉	rlg ₈	rlg ₇	rlg ₆	rlg ₅	rlg ₄	rlg ₃	rlg ₂
	14	rlg ₁₇	rlg ₁₆	rlg ₁₅	rlg ₁₄	rlg ₁₃	rlg ₁₂	rlg ₁₁	rlg ₁₀
ground track (gtk)	15	gtk ₅	gtk ₄	gtk ₃	gtk ₂	gtk ₁	rlg ₂₀	rlg ₁₉	rlg ₁₈
ground speed (gsp)	16	gsp ₅	gsp ₄	gsp ₃	gsp ₂	gsp ₁	gtk ₈	gtk ₇	gtk ₆
time stamp (tag)	17	tag ₂	tag ₁	gsp ₁₁	gsp ₁₀	gsp ₉	gsp ₈	gsp ₇	gsp ₆
flight ID type (fidty)	18	res	res	res	res	tag ₆	tag ₅	tag ₄	tag ₃
callsign (call)	19	call ₇	call ₆	call ₅	call ₄	call ₃	call ₂	call ₁	fidty
	20	call ₁₅	call ₁₄	call ₁₃	call ₁₂	call ₁₁	call ₁₀	call ₉	call ₈
	21	call ₂₃	call ₂₂	call ₂₁	call ₂₀	call ₁₉	call ₁₈	call ₁₇	call ₁₆
	22	call ₃₁	call ₃₀	call ₂₉	call ₂₈	call ₂₇	call ₂₆	call ₂₅	call ₂₄
	23	call ₃₉	call ₃₈	call ₃₇	call ₃₆	call ₃₅	call ₃₄	call ₃₃	call ₃₂
aircraft category (cat)	24	cat ₅	cat ₄	cat ₃	cat ₂	cat ₁	call ₄₂	call ₄₁	call ₄₀
response reservation	25	0	0	0	0	0	1	1	1
c	26	c ₉	c ₁₀	c ₁₁	c ₁₂	c ₁₃	c ₁₄	c ₁₅	c ₁₆
c	27	c ₁	c ₂	c ₃	c ₄	c ₅	c ₆	c ₇	c ₈
flag	-	0	1	1	1	1	1	1	0

Table 7.65: TIS_GRD_VEH_a (TVa): Ground vehicle target message with response reservation

Description	Octet	Bit number							
		8	7	6	5	4	3	2	1
flag	-	0	1	1	1	1	1	1	0
s, ver, rid, a/d	1	s ₂₇	s ₂₆	s ₂₅	0	0	0	0	1
s	2	s ₂₄	s ₂₃	s ₂₂	s ₂₁	s ₂₀	s ₁₉	s ₁₈	s ₁₇
s	3	s ₁₆	s ₁₅	s ₁₄	s ₁₃	s ₁₂	s ₁₁	s ₁₀	s ₉
s	4	s ₈	s ₇	s ₆	s ₅	s ₄	s ₃	s ₂	s ₁
udid, ucd	5	0	0	0	0	0	1	1	1
TIS-B message ID (tmi) TIV ID (tivid)	6	tid ₁	tivid ₃	tivid ₂	tivid ₁	tmi ₄	tmi ₃	tmi ₂	tmi ₁
target identifier (tid)	7	tid ₉	tid ₈	tid ₇	tid ₆	tid ₅	tid ₄	tid ₃	tid ₂
ADS-B fault flag (adsff)	8	tag ₅	tag ₄	tag ₃	tag ₂	tag ₁	adsff	tid ₁₁	tid ₁₀
time stamp(tag) latitude (rlat)	9	rlat ₇	rlat ₆	rlat ₅	rlat ₄	rlat ₃	rlat ₂	rlat ₁	tag ₆
	10	rlat ₁₅	rlat ₁₄	rlat ₁₃	rlat ₁₂	rlat ₁₁	rlat ₁₀	rlat ₉	rlat ₈
longitude (rlg)	11	rlg ₃	rlg ₂	rlg ₁	rlat ₂₀	rlat ₁₉	rlat ₁₈	rlat ₁₇	rlat ₁₆
	12	rlg ₁₁	rlg ₁₀	rlg ₉	rlg ₈	rlg ₇	rlg ₆	rlg ₅	rlg ₄
	13	rlg ₁₉	rlg ₁₈	rlg ₁₇	rlg ₁₆	rlg ₁₅	rlg ₁₄	rlg ₁₃	rlg ₁₂
ground track (gtk)	14	gtk ₇	gtk ₆	gtk ₅	gtk ₄	gtk ₃	gtk ₂	gtk ₁	rlg ₂₀
ground speed (gsp)	15	gsp ₇	gsp ₆	gsp ₅	gsp ₄	gsp ₃	gsp ₂	gsp ₁	gtk ₈
response reservation	16	0	0	0	0	0	1	1	1
c	18	c ₉	c ₁₀	c ₁₁	c ₁₂	c ₁₃	c ₁₄	c ₁₅	c ₁₆
c	19	c ₁	c ₂	c ₃	c ₄	c ₅	c ₆	c ₇	c ₈
flag	-	0	1	1	1	1	1	1	0

7.4.3.1.5.3

Bursts defined for FIS-B tests

Table 7.66: FIS_METAR_a (FMa): METAR message with response reservation

Description	Octet	Bit number							
		8	7	6	5	4	3	2	1
flag	-	0	1	1	1	1	1	1	0
s, ver, rid, a/d	1	s ₂₇	s ₂₆	s ₂₅	0	0	0	0	1
s	2	s ₂₄	s ₂₃	s ₂₂	s ₂₁	s ₂₀	s ₁₉	s ₁₈	s ₁₇
s	3	s ₁₆	s ₁₅	s ₁₄	s ₁₃	s ₁₂	s ₁₁	s ₁₀	s ₉
s	4	s ₈	s ₇	s ₆	s ₅	s ₄	s ₃	s ₂	s ₁
mi	5	0	0	0	0	1	1	1	1
FIS-B message ID (fmi) FIS-B version ID (vers)	6	vers ₄	vers ₃	vers ₂	vers ₁	0	0	0	0
message edition (med) local ID (locl)	7	locl ₅	locl ₄	locl ₃	locl ₂	locl ₁	med ₃	med ₂	med ₁
	8	locl ₁₃	locl ₁₂	locl ₁₁	locl ₁₀	locl ₉	locl ₈	locl ₇	locl ₆
date (date)	9	date ₁	locl ₂₀	locl ₁₉	locl ₁₈	locl ₁₇	locl ₁₆	locl ₁₅	locl ₁₄
time (ti)	10	ti ₄	ti ₃	ti ₂	ti ₁	date ₅	date ₄	date ₃	date ₂
wind direction (wdi)	11	wdi ₁	ti ₁₁	ti ₁₀	ti ₉	ti ₈	ti ₇	ti ₆	ti ₅
wind speed (wsp)	12	wsp ₃	wsp ₂	wsp ₁	wdi ₆	wdi ₅	wdi ₄	wdi ₃	wdi ₂
free text flag (ftxt) max wind flag (mxw) CAVOK flag (cav) TREND report flag (trd)	13	trd	cav	mxw	ftxt	wsp ₇	wsp ₆	wsp ₅	wsp ₄
present weather flag (pwf) recent weather flag (rwf) QFE flag (qfef) temperature (tem)	14	tem ₃	tem ₂	tem ₁	qfef	rwf ₂	rwf ₁	pwf ₂	pwf ₁
dew point temperature (dew)	15	dew ₃	dew ₂	dew ₁	tem ₈	tem ₇	tem ₆	tem ₅	tem ₄
QNH (qnh)	16	qnh ₃	qnh ₂	qnh ₁	dew ₈	dew ₇	dew ₆	dew ₅	dew ₄
wind shear flag (wsf) Ssea flag (ssf) variable wind direction to (vdit) variable wind direction from (vdif)	17	vdi ₁	ssf	wsf	qnh ₈	qnh ₇	qnh ₆	qnh ₅	qnh ₄
wind gust indicator (wgi)	18	vdif ₃	vdif ₂	vdif ₁	vdi ₆	vdi ₅	vdi ₄	vdi ₃	vdi ₂
wind gust indicator (wgi)	19	wgi ₅	wgi ₄	wgi ₃	wgi ₂	wgi ₁	vdif ₆	vdif ₅	vdif ₄
minimum visibility (mis)	20	mis ₆	mis ₅	mis ₄	mis ₃	mis ₂	mis ₁	wgi ₇	wgi ₆
minimum visibility direction (misd) maximum visibility (mas)	21	mas ₅	mas ₄	mas ₃	mas ₂	mas ₁	misd ₃	misd ₂	misd ₁
maximum visibility direction (masd) present weather (pw)	22	pw ₄	pw ₃	pw ₂	pw ₁	masd ₃	masd ₂	masd ₁	mas ₆
cloud no. flag (cno) cloud coverage (cc)	23	cc ₃	cc ₂	cc ₁	cno ₂	cno ₁	pw ₇	pw ₆	pw ₅
cloud height (ch)	24	ch ₈	ch ₇	ch ₆	ch ₅	ch ₄	ch ₃	ch ₂	ch ₁
cloud type (cty) QFE (qfe)	25	qfe ₆	qfe ₅	qfe ₄	qfe ₃	qfe ₂	qfe ₁	cty ₂	cty ₁
recent weather (rw)	26	rw ₆	rw ₅	rw ₄	rw ₃	rw ₂	rw ₁	qfe ₈	qfe ₇
wind shear (ws)	27	ws ₇	ws ₆	ws ₅	ws ₄	ws ₃	ws ₂	ws ₁	rw ₇
sea-surface temperature (sst) state of the sea (ss)	29	ss ₁	sst ₆	sst ₅	sst ₄	sst ₃	sst ₂	sst ₁	ws ₈
free text message (txt)	30	txt ₅	txt ₄	txt ₃	txt ₂	txt ₁	ss ₄	ss ₃	ss ₂
	31	txt _j	txt _{j-1}	txt _{j-2}	txt ₉	txt ₈	txt ₇	txt ₆
response reservation	n-2	0	0	0	0	0	1	1	1
c	n-1	c ₉	c ₁₀	c ₁₁	c ₁₂	c ₁₃	c ₁₄	c ₁₅	c ₁₆
c	n	c ₁	c ₂	c ₃	c ₄	c ₅	c ₆	c ₇	c ₈
flag	-	0	1	1	1	1	1	1	0

Table 7.67: FIS_SPECI_a (FSa): SPECI message with response reservation

Description	Octet	Bit number							
		8	7	6	5	4	3	2	1
flag	-	0	1	1	1	1	1	1	0
s, ver, rid, a/d	1	s ₂₇	s ₂₆	s ₂₅	0	0	0	0	1
s	2	s ₂₄	s ₂₃	s ₂₂	s ₂₁	s ₂₀	s ₁₉	s ₁₈	s ₁₇
s	3	s ₁₆	s ₁₅	s ₁₄	s ₁₃	s ₁₂	s ₁₁	s ₁₀	s ₉
s	4	s ₈	s ₇	s ₆	s ₅	s ₄	s ₃	s ₂	s ₁
mi	5	0	0	0	0	1	1	1	1
FIS-B message ID (fmi) FIS-B version ID (vers)	6	vers ₄	vers ₃	vers ₂	vers ₁	0	1	0	0
message edition (med) local ID (locl)	7	locl ₅	locl ₄	locl ₃	locl ₂	locl ₁	med ₃	med ₂	med ₁
	8	locl ₁₃	locl ₁₂	locl ₁₁	locl ₁₀	locl ₉	locl ₈	locl ₇	locl ₆
date (date)	9	date ₁	locl ₂₀	locl ₁₉	locl ₁₈	locl ₁₇	locl ₁₆	locl ₁₅	locl ₁₄
time (ti)	10	ti ₄	ti ₃	ti ₂	ti ₁	date ₅	date ₄	date ₃	date ₂
wind direction (wdi)	11	wdi ₁	ti ₁₁	ti ₁₀	ti ₉	ti ₈	ti ₇	ti ₆	ti ₅
wind speed (wsp)	12	wsp ₃	wsp ₂	wsp ₁	wdi ₆	wdi ₅	wdi ₄	wdi ₃	wdi ₂
free text flag (ftxt) max wind flag (mxw) CAVOK flag (cav) TREND report flag (trd)	13	trd	cav	mxw	ftxt	wsp ₇	wsp ₆	wsp ₅	wsp ₄
present weather flag (pwf) recent weather flag (rwf) QFE flag (qfef) temperature (tem)	14	tem ₃	tem ₂	tem ₁	qfef	rwf ₂	rwf ₁	pwf ₂	pwf ₁
dew point temperature (dew)	15	dew ₃	dew ₂	dew ₁	tem ₈	tem ₇	tem ₆	tem ₅	tem ₄
QNH (qnh)	16	qnh ₃	qnh ₂	qnh ₁	dew ₈	dew ₇	dew ₆	dew ₅	dew ₄
wind shear flag (wsf) sea flag (ssf) variable wind direction to (vdit)	17	vdi ₁	ssf	wsf	qnh ₈	qnh ₇	qnh ₆	qnh ₅	qnh ₄
variable wind direction from (vdif)	18	vdif ₃	vdif ₂	vdif ₁	vdi ₆	vdi ₅	vdi ₄	vdi ₃	vdi ₂
wind gust indicator (wgi)	19	wgi ₅	wgi ₄	wgi ₃	wgi ₂	wgi ₁	vdif ₆	vdif ₅	vdif ₄
minimum visibility (mis)	20	mis ₆	mis ₅	mis ₄	mis ₃	mis ₂	mis ₁	wgi ₇	wgi ₆
minimum visibility direction (misd) maximum visibility (mas)	21	mas ₅	mas ₄	mas ₃	mas ₂	mas ₁	misd ₃	misd ₂	misd ₁
maximum visibility direction (masd) present weather (pw)	22	pw ₄	pw ₃	pw ₂	pw ₁	masd ₃	masd ₂	masd ₁	mas ₆
cloud no. flag (cno) cloud coverage (cc)	23	cc ₃	cc ₂	cc ₁	cno ₂	cno ₁	pw ₇	pw ₆	pw ₅
cloud height (ch)	24	ch ₈	ch ₇	ch ₆	ch ₅	ch ₄	ch ₃	ch ₂	ch ₁
cloud type (cty) QFE (qfe)	25	qfe ₆	qfe ₅	qfe ₄	qfe ₃	qfe ₂	qfe ₁	cty ₂	cty ₁
recent weather (rw)	26	rw ₆	rw ₅	rw ₄	rw ₃	rw ₂	rw ₁	qfe ₈	qfe ₇
wind shear (ws)	27	ws ₇	ws ₆	ws ₅	ws ₄	ws ₃	ws ₂	ws ₁	rw ₇
sea-surface temperature (sst) state of the sea (ss)	29	ss ₁	sst ₆	sst ₅	sst ₄	sst ₃	sst ₂	sst ₁	ws ₈
free text message (txt)	30	txt ₅	txt ₄	txt ₃	txt ₂	txt ₁	ss ₄	ss ₃	ss ₂
	31	txt _j	txt _{j-1}	txt _{j-2}	txt ₉	txt ₈	txt ₇	txt ₆
response reservation	n-2	0	0	0	0	0	1	1	1
c	n-1	c ₉	c ₁₀	c ₁₁	c ₁₂	c ₁₃	c ₁₄	c ₁₅	c ₁₆
c	n	c ₁	c ₂	c ₃	c ₄	c ₅	c ₆	c ₇	c ₈
flag	-	0	1	1	1	1	1	1	0

Table 7.68: FIS_ATIS_a (FAa): ATIS message with response reservation

Description	Octet	Bit number							
		8	7	6	5	4	3	2	1
flag	-	0	1	1	1	1	1	1	0
s, ver, rid, a/d	1	s ₂₇	s ₂₆	s ₂₅	0	0	0	0	1
s	2	s ₂₄	s ₂₃	s ₂₂	s ₂₁	s ₂₀	s ₁₉	s ₁₈	s ₁₇
s	3	s ₁₆	s ₁₅	s ₁₄	s ₁₃	s ₁₂	s ₁₁	s ₁₀	s ₉
s	4	s ₈	s ₇	s ₆	s ₅	s ₄	s ₃	s ₂	s ₁
mi	5	0	0	0	0	1	1	1	1
FIS-B message ID (fmi) FIS-B version ID (vers) message edition (med)	6	vers ₄	vers ₃	vers ₂	vers ₁	0	0	0	1
local ID(locl)	7	locl ₅	locl ₄	locl ₃	locl ₂	locl ₁	med ₃	med ₂	med ₁
	8	locl ₁₃	locl ₁₂	locl ₁₁	locl ₁₀	locl ₉	locl ₈	locl ₇	locl ₆
date (date)	9	date ₁	locl ₂₀	locl ₁₉	locl ₁₈	locl ₁₇	locl ₁₆	locl ₁₅	locl ₁₄
time (ti)	10	ti ₄	ti ₃	ti ₂	ti ₁	date ₅	date ₄	date ₃	date ₂
holding delay (hd)	11	hd ₁	ti ₁₁	ti ₁₀	ti ₉	ti ₈	ti ₇	ti ₆	ti ₅
transition level (tran)	12	tran ₅	tran ₄	tran ₃	tran ₂	tran ₁	hd ₄	hd ₃	hd ₂
other op. activity flag (othf) other op. activity (oth) airport availability (aavl)	13	aavl ₃	aavl ₂	aavl ₁	oth ₃	oth ₂	oth ₁	othf	tran ₆
	14	aavl ₁₁	aavl ₁₀	aavl ₉	aavl ₈	aavl ₇	aavl ₆	aavl ₅	aavl ₄
wind direction (wdi) wind speed (wsp)	15	wsp ₁	wdi ₆	wdi ₅	wdi ₄	wdi ₃	wdi ₂	wdi ₁	aavl ₁₂
temperature (tem)	16	tem ₂	tem ₁	wsp ₇	wsp ₆	wsp ₅	wsp ₄	wsp ₃	wsp ₂
dew point (dew)	17	dew ₂	dew ₁	tem ₈	tem ₇	tem ₆	tem ₅	tem ₄	tem ₃
QNH (qnh)	18	qnh ₂	qnh ₁	dew ₈	dew ₇	dew ₆	dew ₅	dew ₄	dew ₃
free text flag (ftxt) max wind flag (mxw) CAVOK flag (cav)	19	mxw	ftxt	qnh ₈	qnh ₇	qnh ₆	qnh ₅	qnh ₄	qnh ₃
TREND report flag (trd) QFE flag (qfef) wind shear flag (ws) present weather flag (pwf) recent weather flag (rwf) variable wind direction to (vdit)	20	rwf ₂	rwf ₁	pwf ₂	pwf ₁	ws	qfef	trd	cav
variable wind direction from (vdif)	21	vdif ₂	vdif ₁	vdit ₆	vdit ₅	vdit ₄	vdit ₃	vdit ₂	vdit ₁
wind gust indicator (wgi)	22	wgi ₄	wgi ₃	wgi ₂	wgi ₁	vdif ₆	vdif ₅	vdif ₄	vdif ₃
minimum visibility (mis)	23	mis ₅	mis ₄	mis ₃	mis ₂	mis ₁	wgi ₇	wgi ₆	wgi ₅
minimum visibility direction (misd) maximum visibility (mas)	24	mas ₄	mas ₃	mas ₂	mas ₁	misd ₃	misd ₂	misd ₁	mis ₆
maximum visibility direction (masd) cloud no. flag (cno) cloud coverage (cc)	25	cc ₁	cno ₂	cno ₁	masd ₃	masd ₂	masd ₁	mas ₆	mas ₅
cloud height (ch)	26	ch ₆	ch ₅	ch ₄	ch ₃	ch ₂	ch ₁	cc ₃	cc ₂
cloud type (cty) present weather (pw) recent weather (rw)	27	pw ₄	pw ₃	pw ₂	pw ₁	cty ₂	cty ₁	ch ₈	ch ₇
QFE (qfe)	28	rw ₅	rw ₄	rw ₃	rw ₂	rw ₁	pw ₇	pw ₆	pw ₅
free text message (txt)	29	qfe ₆	qfe ₅	qfe ₄	qfe ₃	qfe ₂	qfe ₁	rw ₇	rw ₆
	30	txt ₆	txt ₅	txt ₄	txt ₃	txt ₂	txt ₁	qfe ₈	qfe ₇
	31	txt _j	txt _{j-1}	txt _{j-2}	txt ₁₀	txt ₉	txt ₈	txt ₇
response reservation field	n-2	0	0	0	0	0	1	1	1
c	n-1	c ₉	c ₁₀	c ₁₁	c ₁₂	c ₁₃	c ₁₄	c ₁₅	c ₁₆
c	n	c ₁	c ₂	c ₃	c ₄	c ₅	c ₆	c ₇	c ₈
flag	-	0	1	1	1	1	1	1	0

Table 7.69: FIS_RCN_A (FRa): RCN message burst format with response reservation

Description	Octet	Bit number							
		8	7	6	5	4	3	2	1
flag	-	0	1	1	1	1	1	1	0
s, ver, rid, a/d	1	s ₂₇	s ₂₆	s ₂₅	0	0	0	0	1
s	2	s ₂₄	s ₂₃	s ₂₂	s ₂₁	s ₂₀	s ₁₉	s ₁₈	s ₁₇
s	3	s ₁₆	s ₁₅	s ₁₄	s ₁₃	s ₁₂	s ₁₁	s ₁₀	s ₉
s	4	s ₈	s ₇	s ₆	s ₅	s ₄	s ₃	s ₂	s ₁
mi	5	0	0	0	0	1	1	1	1
FIS-B message ID (fmi) FIS-B version ID (vers)	6	vers ₄	vers ₃	vers ₂	vers ₁	0	0	1	0
message edition (med) local ID (locl)	7	locl ₅	locl ₄	locl ₃	locl ₂	locl ₁	med ₃	med ₂	med ₁
	8	locl ₁₃	locl ₁₂	locl ₁₁	locl ₁₀	locl ₉	locl ₈	locl ₇	locl ₆
date (date)	9	date ₁	locl ₂₀	locl ₁₉	locl ₁₈	locl ₁₇	locl ₁₆	locl ₁₅	locl ₁₄
time (ti)	10	ti ₄	ti ₃	ti ₂	ti ₁	date ₅	date ₄	date ₃	date ₂
braking action (brk)	11	brk ₁	ti ₁₁	ti ₁₀	ti ₉	ti ₈	ti ₇	ti ₆	ti ₅
runway ID (run)	12	run ₆	run ₅	run ₄	run ₃	run ₂	run ₁	brk ₃	brk ₂
approach type flag (aptf) approach type (apty)	13	apty ₄	apty ₃	apty ₂	apty ₁	aptf ₂	aptf ₁	run ₈	run ₇
reduced runway length (rrl)	14	rrl ₈	rrl ₇	rrl ₆	rrl ₅	rrl ₄	rrl ₃	rrl ₂	rrl ₁
reduced runway width (rrw) runway deposits (rdp)	15	rdp ₁	rrw ₇	rrw ₆	rrw ₅	rrw ₄	rrw ₃	rrw ₂	rrw ₁
runway contamination (rcon) depth of deposit (dod)	16	dod ₂	dod ₁	rcon ₃	rcon ₂	rcon ₁	rdp ₄	rdp ₃	rdp ₂
RVR touchdown (rvt)	17	rvt ₃	rvt ₂	rvt ₁	dod ₇	dod ₆	dod ₅	dod ₄	dod ₃
RVR midpoint (rvm)	18	rvm ₅	rvm ₄	rvm ₃	rvm ₂	rvm ₁	rvt ₆	rvt ₅	rvt ₄
RVR endpoint (rve) RVR source (rso)	19	rso ₁	rve ₆	rve ₅	rve ₄	rve ₃	rve ₂	rve ₁	rvm ₆
runway in use (rus) runway availability (ravl)	20	ravl ₅	ravl ₄	ravl ₃	ravl ₂	ravl ₁	rus ₂	rus ₁	rso ₂
wind shear	21	ws	ravl ₁₂	ravl ₁₁	ravl ₁₀	ravl ₉	ravl ₈	ravl ₇	ravl ₆
response reservation field	22	0	0	0	0	0	1	1	1
c	23	c ₉	c ₁₀	c ₁₁	c ₁₂	c ₁₃	c ₁₄	c ₁₅	c ₁₆
c	24	c ₁	c ₂	c ₃	c ₄	c ₅	c ₆	c ₇	c ₈
flag	-	0	1	1	1	1	1	1	0

Table 7.70: FIS_SIGMET_a (FSa): SIGMET message with response reservation

Description	Octet	Bit number							
		8	7	6	5	4	3	2	1
flag	-	0	1	1	1	1	1	1	0
s, ver, rid, a/d	1	s ₂₇	s ₂₆	s ₂₅	0	0	0	0	1
s	2	s ₂₄	s ₂₃	s ₂₂	s ₂₁	s ₂₀	s ₁₉	s ₁₈	s ₁₇
s	3	s ₁₆	s ₁₅	s ₁₄	s ₁₃	s ₁₂	s ₁₁	s ₁₀	s ₉
s	4	s ₈	s ₇	s ₆	s ₅	s ₄	s ₃	s ₂	s ₁
mi	5	0	0	0	0	1	1	1	1
FIS-B message ID (fmi) FIS-B sequence number (sqn)	6	sqn ₄	sqn ₃	sqn ₂	sqn ₁	0	0	1	1
message edition (med)	7	loci ₅	loci ₄	loci ₃	loci ₂	loci ₁	med ₃	med ₂	med ₁
location indicator (loci)	8	loci ₁₃	loci ₁₂	loci ₁₁	loci ₁₀	loci ₉	loci ₈	loci ₇	loci ₆
originator indicator (ori)	9	ori ₁	loci ₂₀	loci ₁₉	loci ₁₈	loci ₁₇	loci ₁₆	loci ₁₅	loci ₁₄
	10	ori ₉	ori ₈	ori ₇	ori ₆	ori ₅	ori ₄	ori ₃	ori ₂
	11	ori ₁₇	ori ₁₆	ori ₁₅	ori ₁₄	ori ₁₃	ori ₁₂	ori ₁₁	ori ₁₀
date issued (di)	12	di ₅	di ₄	di ₃	di ₂	di ₁	ori ₂₀	ori ₁₉	ori ₁₈
time issued (ti)	13	ti ₈	ti ₇	ti ₆	ti ₅	ti ₄	ti ₃	ti ₂	ti ₁
date valid to (dvt)	14	dvt ₅	dvt ₄	dvt ₃	dvt ₂	dvt ₁	ti ₁₁	ti ₁₀	ti ₉
time valid to (tvt)	15	tvt ₈	tvt ₇	tvt ₆	tvt ₅	tvt ₄	tvt ₃	tvt ₂	tvt ₁
SIGMET flag (sfl) free text flag (ftxt) phenomenon / condition reported (crp)	14	crp ₃	crp ₂	crp ₁	ftxt	sfl	tvt ₁₁	tvt ₁₀	tvt ₉
free text message (txt)	15	txt ₆	txt ₅	txt ₄	txt ₃	txt ₂	txt ₁	crp ₅	crp ₄
	16	txt _j	txt _{j-1}	txt _{j-2}	txt ₁₀	txt ₉	txt ₈	txt ₇
response reservation field	n-2	0	0	0	0	0	1	1	1
c	n-1	c ₉	c ₁₀	c ₁₁	c ₁₂	c ₁₃	c ₁₄	c ₁₅	c ₁₆
c	n	c ₁	c ₂	c ₃	c ₄	c ₅	c ₆	c ₇	c ₈
flag	-	0	1	1	1	1	1	1	0

Table 7.71: FIS_TSA_CTR_a (FTCa): TSA CTR Zone message with response reservation

Description	Octet	Bit number							
		8	7	6	5	4	3	2	1
flag	-	0	1	1	1	1	1	1	0
s, ver, rid, a/d	1	s ₂₇	s ₂₆	s ₂₅	0	0	0	0	1
s	2	s ₂₄	s ₂₃	s ₂₂	s ₂₁	s ₂₀	s ₁₉	s ₁₈	s ₁₇
s	3	s ₁₆	s ₁₅	s ₁₄	s ₁₃	s ₁₂	s ₁₁	s ₁₀	s ₉
s	4	s ₈	s ₇	s ₆	s ₅	s ₄	s ₃	s ₂	s ₁
mi	5	0	0	0	0	1	1	1	1
FIS-B message ID (fmi) version ID (vers) message edition (med)	6	vers ₄	vers ₃	vers ₂	vers ₁	0	1	1	0
date (date)	7	date ₅	date ₄	date ₃	date ₂	date ₁	med ₃	med ₂	med ₁
time (ti)	8	ti ₈	ti ₇	ti ₆	ti ₅	ti ₄	ti ₃	ti ₂	ti ₁
number of TSAs (NoT)	9	NoT ₅	NoT ₄	NoT ₃	NoT ₂	NoT ₁	ti ₁₁	ti ₁₀	ti ₉
type of area (toa) Active flag (act) local ID (locl)	10	locl ₄	locl ₃	locl ₂	locl ₁	act ₁	toa ₃	toa ₂	toa ₁
	11	locl ₁₂	locl ₁₁	locl ₁₀	locl ₉	locl ₈	locl ₇	locl ₆	locl ₅
	12	locl ₂₀	locl ₁₉	locl ₁₈	locl ₁₇	locl ₁₆	locl ₁₅	locl ₁₄	locl ₁₃
supplement to local ID (sloc) active from/to date (actdat)	13	acdat ₃	acdat ₂	acdat ₁	sloc ₅	sloc ₄	sloc ₃	sloc ₂	sloc ₁
active from/to time (actim)	14	actim ₆	actim ₅	actim ₄	actim ₃	actim ₂	actim ₁	acdat ₅	acdat ₄
TWR frequency (freq)	15	freq ₃	freq ₂	freq ₁	actim ₁₁	actim ₁₀	actim ₉	actim ₈	actim ₇
	16	freq ₁₁	freq ₁₀	freq ₉	freq ₈	freq ₇	freq ₆	freq ₅	freq ₄
response reservation field	n-2	0	0	0	0	0	1	1	1
c	n-1	c ₉	c ₁₀	c ₁₁	c ₁₂	c ₁₃	c ₁₄	c ₁₅	c ₁₆
c	n	c ₁	c ₂	c ₃	c ₄	c ₅	c ₆	c ₇	c ₈
flag	-	0	1	1	1	1	1	1	0

Table 7.72: FIS_TSA_DNG_a (FTDa): TSA DNG Zone message with response reservation

Description	Octet	Bit number							
		8	7	6	5	4	3	2	1
flag	-	0	1	1	1	1	1	1	0
s, ver, rid, a/d	1	s ₂₇	s ₂₆	s ₂₅	0	0	0	0	1
s	2	s ₂₄	s ₂₃	s ₂₂	s ₂₁	s ₂₀	s ₁₉	s ₁₈	s ₁₇
s	3	s ₁₆	s ₁₅	s ₁₄	s ₁₃	s ₁₂	s ₁₁	s ₁₀	s ₉
s	4	s ₈	s ₇	s ₆	s ₅	s ₄	s ₃	s ₂	s ₁
mi	5	0	0	0	0	1	1	1	1
FIS-B message ID (fmi) version ID (vers) message edition (med)	6	vers ₄	vers ₃	vers ₂	vers ₁	0	1	1	0
date (date)	7	date ₅	date ₄	date ₃	date ₂	date ₁	med ₃	med ₂	med ₁
time (ti)	8	ti ₈	ti ₇	ti ₆	ti ₅	ti ₄	ti ₃	ti ₂	ti ₁
number of TSAs (NoT)	9	NoT ₅	NoT ₄	NoT ₃	NoT ₂	NoT ₁	ti ₁₁	ti ₁₀	ti ₉
type of area (toa) active flag (act) state ID (stid)	10	stid ₄	stid ₃	stid ₂	stid ₁	act ₁	toa ₃	toa ₂	toa ₁
area leap number (aln)	11	aln ₂	aln ₁	stid ₁₀	stid ₉	stid ₈	stid ₇	stid ₆	stid ₅
	12	aln ₁₀	aln ₉	aln ₈	aln ₇	aln ₆	aln ₅	aln ₄	aln ₃
supplement to area leap number (saln)	13	saln ₅	saln ₄	saln ₃	saln ₂	saln ₁	aln ₁₃	aln ₁₂	aln ₁₁
active from/to date (actdat) active from/to time (actim)	14	actim ₃	actim ₂	actim ₁	acdat ₅	acdat ₄	acdat ₃	acdat ₂	acdat ₁
	15	actim ₁₁	actim ₁₀	actim ₉	actim ₈	actim ₇	actim ₆	actim ₅	actim ₄
response reservation field	n-2	0	0	0	0	0	1	1	1
c	n-1	c ₉	c ₁₀	c ₁₁	c ₁₂	c ₁₃	c ₁₄	c ₁₅	c ₁₆
c	n	c ₁	c ₂	c ₃	c ₄	c ₅	c ₆	c ₇	c ₈
flag	-	0	1	1	1	1	1	1	0

Table 7.73: FIS_REQUEST_a (FQa): Request message with a null reservation

Description	Octet	Bit number							
		8	7	6	5	4	3	2	1
flag	-	0	1	1	1	1	1	1	0
s, ver, rid, a/d	1	s ₂₇	s ₂₆	s ₂₅	0	0	0	1	1
s	2	s ₂₄	s ₂₃	s ₂₂	s ₂₁	s ₂₀	s ₁₉	s ₁₈	s ₁₇
s	3	s ₁₆	s ₁₅	s ₁₄	s ₁₃	s ₁₂	s ₁₁	s ₁₀	s ₉
s	4	s ₈	s ₇	s ₆	s ₅	s ₄	s ₃	s ₂	s ₁
mi = general request burst r-mi = FIS-B service indicator	5	0	1	1	1	1	0	0	1
FIS-B message ID (fmi) message requested (mrq)	6	mrq ₁	0	1	0	1	0	0	0
local ID (locl)	7	locl ₅	locl ₄	locl ₃	locl ₂	locl ₁	mrq ₄	mrq ₃	mrq ₂
	8	locl ₁₃	locl ₁₂	locl ₁₁	locl ₁₀	locl ₉	locl ₈	locl ₇	locl ₆
res	9	res	locl ₂₀	locl ₁₉	locl ₁₈	locl ₁₇	locl ₁₆	locl ₁₅	locl ₁₄
res, null res field	10	res	res	res	res	res	res	0	0
null res field	11	0	0	0	0	0	0	0	0
c	12	c ₉	c ₁₀	c ₁₁	c ₁₂	c ₁₃	c ₁₄	c ₁₅	c ₁₆
c	13	c ₁	c ₂	c ₃	c ₄	c ₅	c ₆	c ₇	c ₈
flag	-	0	1	1	1	1	1	1	0

Table 7.74: FIS_REQUEST_b (FQb): Request message with a unicast reservation

Description	Octet	Bit number								
		8	7	6	5	4	3	2	1	
flag	-	0	1	1	1	1	1	1	1	0
s, ver, rid, a/d	1	s ₂₇	s ₂₆	s ₂₅	0	0	0	0	1	1
s	2	s ₂₄	s ₂₃	s ₂₂	s ₂₁	s ₂₀	s ₁₉	s ₁₈	s ₁₇	s ₁₆
s	3	s ₁₆	s ₁₅	s ₁₄	s ₁₃	s ₁₂	s ₁₁	s ₁₀	s ₉	s ₈
s	4	s ₈	s ₇	s ₆	s ₅	s ₄	s ₃	s ₂	s ₁	s ₀
mi = general request burst r-mi = FIS-B service indicator	5	0	1	1	1	1	0	0	0	1
FIS-B message ID (fmi) message requested (mrq)	6	mrq ₁	0	1	0	1	0	0	0	0
local ID (locl)	7	locl ₅	locl ₄	locl ₃	locl ₂	locl ₁	mrq ₄	mrq ₃	mrq ₂	mrq ₁
	8	locl ₁₃	locl ₁₂	locl ₁₁	locl ₁₀	locl ₉	locl ₈	locl ₇	locl ₆	locl ₅
res	9	res	locl ₂₀	locl ₁₉	locl ₁₈	locl ₁₇	locl ₁₆	locl ₁₅	locl ₁₄	locl ₁₃
d	10	d ₂₄	d ₂₃	d ₂₂	d ₂₁	d ₂₀	d ₁₉	d ₁₈	d ₁₇	d ₁₆
d	11	d ₁₆	d ₁₅	d ₁₄	d ₁₃	d ₁₂	d ₁₁	d ₁₀	d ₉	d ₈
d	12	d ₈	d ₇	d ₆	d ₅	d ₄	d ₃	d ₂	d ₁	d ₀
ro, sdf, d	13	ro ₁₂	ro ₁₁	ro ₁₀	ro ₉	sdf	d ₂₇	d ₂₆	d ₂₅	d ₂₄
ro	14	ro ₈	ro ₇	ro ₆	ro ₅	ro ₄	ro ₃	ro ₂	ro ₁	ro ₀
lg	15	lg ₈	lg ₇	lg ₆	lg ₅	lg ₄	lg ₃	lg ₂	lg ₁	lg ₀
pr	16	0	0	1	0	pr ₄	pr ₃	pr ₂	pr ₁	pr ₀
c	17	c ₉	c ₁₀	c ₁₁	c ₁₂	c ₁₃	c ₁₄	c ₁₅	c ₁₆	c ₁₇
c	18	c ₁	c ₂	c ₃	c ₄	c ₅	c ₆	c ₇	c ₈	c ₉
flag	-	0	1	1	1	1	1	1	1	0

Table 7.75: FIS_REQUEST_c (FQc): Request message with a response reservation

Description	Octet	Bit number								
		8	7	6	5	4	3	2	1	
flag	-	0	1	1	1	1	1	1	1	0
s, ver, rid, a/d	1	s ₂₇	s ₂₆	s ₂₅	0	0	0	0	0	1
s	2	s ₂₄	s ₂₃	s ₂₂	s ₂₁	s ₂₀	s ₁₉	s ₁₈	s ₁₇	s ₁₆
s	3	s ₁₆	s ₁₅	s ₁₄	s ₁₃	s ₁₂	s ₁₁	s ₁₀	s ₉	s ₈
s	4	s ₈	s ₇	s ₆	s ₅	s ₄	s ₃	s ₂	s ₁	s ₀
mi = general request burst r-mi = FIS-B service indicator	5	0	1	1	1	1	0	0	0	1
FIS-B message ID (fmi) message requested (mrq)	6	mrq ₁	0	1	0	1	0	0	0	0
local ID (locl)	7	locl ₅	locl ₄	locl ₃	locl ₂	locl ₁	mrq ₄	mrq ₃	mrq ₂	mrq ₁
	8	locl ₁₃	locl ₁₂	locl ₁₁	locl ₁₀	locl ₉	locl ₈	locl ₇	locl ₆	locl ₅
res	9	res	locl ₂₀	locl ₁₉	locl ₁₈	locl ₁₇	locl ₁₆	locl ₁₅	locl ₁₄	locl ₁₃
d	10	d ₂₄	d ₂₃	d ₂₂	d ₂₁	d ₂₀	d ₁₉	d ₁₈	d ₁₇	d ₁₆
d	11	d ₁₆	d ₁₅	d ₁₄	d ₁₃	d ₁₂	d ₁₁	d ₁₀	d ₉	d ₈
d	12	d ₈	d ₇	d ₆	d ₅	d ₄	d ₃	d ₂	d ₁	d ₀
response res, d	13	0	0	0	0	0	d ₂₇	d ₂₆	d ₂₅	d ₂₄
c	14	c ₉	c ₁₀	c ₁₁	c ₁₂	c ₁₃	c ₁₄	c ₁₅	c ₁₆	c ₁₇
c	15	c ₁	c ₂	c ₃	c ₄	c ₅	c ₆	c ₇	c ₈	c ₉
flag	-	0	1	1	1	1	1	1	1	0

Table 7.76: FIS_REQUEST_d (FQd): Request message with a broadcast unicast reservation

Description	Octet	Bit number							
		8	7	6	5	4	3	2	1
flag	-	0	1	1	1	1	1	1	0
s, ver, rid, a/d	1	s ₂₇	s ₂₆	s ₂₅	0	0	0	1	1
s	2	s ₂₄	s ₂₃	s ₂₂	s ₂₁	s ₂₀	s ₁₉	s ₁₈	s ₁₇
s	3	s ₁₆	s ₁₅	s ₁₄	s ₁₃	s ₁₂	s ₁₁	s ₁₀	s ₉
s	4	s ₈	s ₇	s ₆	s ₅	s ₄	s ₃	s ₂	s ₁
mi = general request burst r-mi = FIS-B service indicator	5	0	1	1	1	1	0	0	1
FIS-B message ID (fmi) message requested (mrq)	6	mrq ₁	0	1	0	1	0	0	0
local ID (locl)	7	locl ₅	locl ₄	locl ₃	locl ₂	locl ₁	mrq ₄	mrq ₃	mrq ₂
	8	locl ₁₃	locl ₁₂	locl ₁₁	locl ₁₀	locl ₉	locl ₈	locl ₇	locl ₆
res	9	res	locl ₂₀	locl ₁₉	locl ₁₈	locl ₁₇	locl ₁₆	locl ₁₅	locl ₁₄
ro, sdf, d	10	ro ₁₂	ro ₁₁	ro ₁₀	ro ₉	sdf	d ₂₇	d ₂₆	d ₂₅
ro	11	ro ₈	ro ₇	ro ₆	ro ₅	ro ₄	ro ₃	ro ₂	ro ₁
lg	12	lg ₈	lg ₇	lg ₆	lg ₅	lg ₄	lg ₃	lg ₂	lg ₁
pr	13	0	0	1	0	pr ₄	pr ₃	pr ₂	pr ₁
c	14	c ₉	c ₁₀	c ₁₁	c ₁₂	c ₁₃	c ₁₄	c ₁₅	c ₁₆
c	15	c ₁	c ₂	c ₃	c ₄	c ₅	c ₆	c ₇	c ₈
flag	-	0	1	1	1	1	1	1	0

7.4.3.1.5.4

Bursts defined for GNS-B tests

Table 7.77: GNS_TYPE1_a (G1a): GNS-B Type 1 message with response reservation

Description	Octet	Bit number							
		8	7	6	5	4	3	2	1
flag	-	0	1	1	1	1	1	1	0
s, ver, rid, a/d	1	s ₂₇	s ₂₆	s ₂₅	0	0	0	0	1
s	2	s ₂₄	s ₂₃	s ₂₂	s ₂₁	s ₂₀	s ₁₉	s ₁₈	s ₁₇
s	3	s ₁₆	s ₁₅	s ₁₄	s ₁₃	s ₁₂	s ₁₁	s ₁₀	s ₉
s	4	s ₈	s ₇	s ₆	s ₅	s ₄	s ₃	s ₂	s ₁
udid, ucd, mi	5	0	0	0	1	1	1	1	1
message block identifier (mbi)	6	mbi ₈	mbi ₇	mbi ₆	mbi ₅	mbi ₄	mbi ₃	mbi ₂	mbi ₁
GNS-B ID (gid)	7	gid ₈	gid ₇	gid ₆	gid ₅	gid ₄	gid ₃	gid ₂	gid ₁
	8	gid ₁₆	gid ₁₅	gid ₁₄	gid ₁₃	gid ₁₂	gid ₁₁	gid ₁₀	gid ₉
	9	gid ₂₄	gid ₂₃	gid ₂₂	gid ₂₁	gid ₂₀	gid ₁₉	gid ₁₈	gid ₁₇
message identifier (gmi)	10	0	0	0	0	0	0	0	1
message length (len)	11	len ₈	len ₇	len ₆	len ₅	len ₄	len ₃	len ₂	len ₁
modified Z-count (zc)	12	zc ₈	zc ₇	zc ₆	zc ₅	zc ₄	zc ₃	zc ₂	zc ₁
additional message flag (amf)	13	amf ₂	amf ₁	zc ₁₄	zc ₁₃	zc ₁₂	zc ₁₁	zc ₁₀	zc ₉
number of measurements (n) measurement type (t)	14	t ₃	t ₂	t ₁	n ₅	n ₄	n ₃	n ₂	n ₁
ephemeris decorrelation parameter (edp)	15	edp ₈	edp ₇	edp ₆	edp ₅	edp ₄	edp ₃	edp ₂	edp ₁
ephemeris CRC(ec)	16	ec ₈	ec ₇	ec ₆	ec ₅	ec ₄	ec ₃	ec ₂	ec ₁
	17	ec ₁₆	ec ₁₅	ec ₁₄	ec ₁₃	ec ₁₂	ec ₁₁	ec ₁₀	ec ₉
source availability duration (ad)	18	ad ₈	ad ₇	ad ₆	ad ₅	ad ₄	ad ₃	ad ₂	ad ₁
for N measurement blocks (i=1 to i=N): ranging source ID (id)	19+(i-1)x11	id ₈	id ₇	id ₆	id ₅	id ₄	id ₃	id ₂	id ₁
issue of data (iod)	20+(i-1)x11	iod ₈	iod ₇	iod ₆	iod ₅	iod ₄	iod ₃	iod ₂	iod ₁
pseudorange correction (prc)	21+(i-1)x11	prc ₈	prc ₇	prc ₆	prc ₅	prc ₄	prc ₃	prc ₂	prc ₁
	22+(i-1)x11	prc ₁₆	prc ₁₅	prc ₁₄	prc ₁₃	prc ₁₂	prc ₁₁	prc ₁₀	prc ₉
range rate correction (rrc)	23+(i-1)x11	rrc ₈	rrc ₇	rrc ₆	rrc ₅	rrc ₄	rrc ₃	rrc ₂	rrc ₁
	24+(i-1)x11	rrc ₁₆	rrc ₁₅	rrc ₁₄	rrc ₁₃	rrc ₁₂	rrc ₁₁	rrc ₁₀	rrc ₉
σ_{pr_gnd} (sd)	25+(i-1)x11	sd ₈	sd ₇	sd ₆	sd ₅	sd ₄	sd ₃	sd ₂	sd ₁
integrity parameter B1 (b1)	26+(i-1)x11	b1 ₈	b1 ₇	b1 ₆	b1 ₅	b1 ₄	b1 ₃	b1 ₂	b1 ₁
integrity parameter B2 (b2)	27+(i-1)x11	b2 ₈	b2 ₇	b2 ₆	b2 ₅	b2 ₄	b2 ₃	b2 ₂	b2 ₁

Description	Octet	Bit number							
		8	7	6	5	4	3	2	1
integrity parameter B3 (b3)	28+(i-1)x11	b3 ₈	b3 ₇	b3 ₆	b3 ₅	b3 ₄	b3 ₃	b3 ₂	b3 ₁
integrity parameter B4 (b4)	29+(i-1)x11	b4 ₈	b4 ₇	b4 ₆	b4 ₅	b4 ₄	b4 ₃	b4 ₂	b4 ₁
GNS-B message CRC (gc)	30+(N-1)x11	gc ₈	gc ₇	gc ₆	gc ₅	gc ₄	gc ₃	gc ₂	gc ₁
	31+(N-1)x11	gc ₁₆	gc ₁₅	gc ₁₄	gc ₁₃	gc ₁₂	gc ₁₁	gc ₁₀	gc ₉
	32+(N-1)x11	gc ₂₄	gc ₂₃	gc ₂₂	gc ₂₁	gc ₂₀	gc ₁₉	gc ₁₈	gc ₁₇
	33+(N-1)x11	gc ₃₂	gc ₃₁	gc ₃₀	gc ₂₉	gc ₂₈	gc ₂₇	gc ₂₆	gc ₂₅
response reservation field	34+(N-1)x11	0	0	0	0	0	1	1	1
c	35+(N-1)x11	c ₉	c ₁₀	c ₁₁	c ₁₂	c ₁₃	c ₁₄	c ₁₅	c ₁₆
c	36+(N-1)x11	c ₁	c ₂	c ₃	c ₄	c ₅	c ₆	c ₇	c ₈
flag	-	0	1	1	1	1	1	1	0

Table 7.78: GNS_TYPE2_a (G2a): GNS-B Type 2 message with response reservation

Description	Octet	Bit number							
		8	7	6	5	4	3	2	1
flag	-	0	1	1	1	1	1	1	0
s, ver, rid, a/d	1	s ₂₇	s ₂₆	s ₂₅	0	0	0	0	1
s	2	s ₂₄	s ₂₃	s ₂₂	s ₂₁	s ₂₀	s ₁₉	s ₁₈	s ₁₇
s	3	s ₁₆	s ₁₅	s ₁₄	s ₁₃	s ₁₂	s ₁₁	s ₁₀	s ₉
s	4	s ₈	s ₇	s ₆	s ₅	s ₄	s ₃	s ₂	s ₁
udid, ucd, mi	5	0	0	0	1	1	1	1	1
message block identifier (mbi)	6	mbi ₈	mbi ₇	mbi ₆	mbi ₅	mbi ₄	mbi ₃	mbi ₂	mbi ₁
GNS-B ID (gid)	7	gid ₈	gid ₇	gid ₆	gid ₅	gid ₄	gid ₃	gid ₂	gid ₁
	8	gid ₁₆	gid ₁₅	gid ₁₄	gid ₁₃	gid ₁₂	gid ₁₁	gid ₁₀	gid ₉
	9	gid ₂₄	gid ₂₃	gid ₂₂	gid ₂₁	gid ₂₀	gid ₁₉	gid ₁₈	gid ₁₇
message identifier (gmi)	10	0	0	0	0	0	0	1	0
message length (len)	11	len ₈	len ₇	len ₆	len ₅	len ₄	len ₃	len ₂	len ₁
GNS-B reference receivers (r) GNS-B accuracy designator letter (ac) GNS-B continuity/integrity designator (cid)	12	cid ₃	cid ₂	cid ₁	res	ac ₂	ac ₁	r ₂	r ₁
local magnetic variation (v)	13	v ₈	v ₇	v ₆	v ₅	v ₄	v ₃	v ₂	v ₁
res	14	res	res	res	res	res	v ₁₁	v ₁₀	v ₉
σ vert iono grad (vi)	15	vi ₈	vi ₇	vi ₆	vi ₅	vi ₄	vi ₃	vi ₂	vi ₁
refractivity index (i)	16	i ₈	i ₇	i ₆	i ₅	i ₄	i ₃	i ₂	i ₁

Description	Octet	Bit number							
		8	7	6	5	4	3	2	1
scale height (h)	17	h ₈	h ₇	h ₆	h ₅	h ₄	h ₃	h ₂	h ₁
refractivity uncertainty (u)	18	u ₈	u ₇	u ₆	u ₅	u ₄	u ₃	u ₂	u ₁
latitude (lat)	19	lat ₈	lat ₇	lat ₆	lat ₅	lat ₄	lat ₃	lat ₂	lat ₁
	20	lat ₁₆	lat ₁₅	lat ₁₄	lat ₁₃	lat ₁₂	lat ₁₁	lat ₁₀	lat ₉
	21	lat ₂₄	lat ₂₃	lat ₂₂	lat ₂₁	lat ₂₀	lat ₁₉	lat ₁₈	lat ₁₇
	22	lat ₃₂	lat ₃₁	lat ₃₀	lat ₂₉	lat ₂₈	lat ₂₇	lat ₂₆	lat ₂₅
longitude (lon)	23	lon ₈	lon ₇	lon ₆	lon ₅	lon ₄	lon ₃	lon ₂	lon ₁
	24	lon ₁₆	lon ₁₅	lon ₁₄	lon ₁₃	lon ₁₂	lon ₁₁	lon ₁₀	lon ₉
	25	lon ₂₄	lon ₂₃	lon ₂₂	lon ₂₁	lon ₂₀	lon ₁₉	lon ₁₈	lon ₁₇
	26	lon ₃₂	lon ₃₁	lon ₃₀	lon ₂₉	lon ₂₈	lon ₂₇	lon ₂₆	lon ₂₅
ellipsoid height (h)	27	h ₈	h ₇	h ₆	h ₅	h ₄	h ₃	h ₂	h ₁
	28	h ₁₆	h ₁₅	h ₁₄	h ₁₃	h ₁₂	h ₁₁	h ₁₀	h ₉
	29	h ₂₄	h ₂₃	h ₂₂	h ₂₁	h ₂₀	h ₁₉	h ₁₈	h ₁₇
GNS-B Message CRC (gc)	30	gc ₈	gc ₇	gc ₆	gc ₅	gc ₄	gc ₃	gc ₂	gc ₁
	31	gc ₁₆	gc ₁₅	gc ₁₄	gc ₁₃	gc ₁₂	gc ₁₁	gc ₁₀	gc ₉
	32	gc ₂₄	gc ₂₃	gc ₂₂	gc ₂₁	gc ₂₀	gc ₁₉	gc ₁₈	gc ₁₇
	33	gc ₃₂	gc ₃₁	gc ₃₀	gc ₂₉	gc ₂₈	gc ₂₇	gc ₂₆	gc ₂₅
response reservation field	34	0	0	0	0	0	1	1	1
c	35	c ₉	c ₁₀	c ₁₁	c ₁₂	c ₁₃	c ₁₄	c ₁₅	c ₁₆
c	36	c ₁	c ₂	c ₃	c ₄	c ₅	c ₆	c ₇	c ₈
flag	-	0	1	1	1	1	1	1	0

Table 7.79: GNS_TYPE4_a (G4a): GNS-B Type 4 message with response reservation

Description	Octet	Bit number							
		8	7	6	5	4	3	2	1
flag	-	0	1	1	1	1	1	1	0
s, ver, rid, a/d	1	s ₂₇	s ₂₆	s ₂₅	0	0	0	0	1
s	2	s ₂₄	s ₂₃	s ₂₂	s ₂₁	s ₂₀	s ₁₉	s ₁₈	s ₁₇
s	3	s ₁₆	s ₁₅	s ₁₄	s ₁₃	s ₁₂	s ₁₁	s ₁₀	s ₉
s	4	s ₈	s ₇	s ₆	s ₅	s ₄	s ₃	s ₂	s ₁
udid, ucd, mi	5	0	0	0	1	1	1	1	1
message block identifier (mbi)	6	mbi ₈	mbi ₇	mbi ₆	mbi ₅	mbi ₄	mbi ₃	mbi ₂	mbi ₁
GNS-B ID (gid)	7	gid ₈	gid ₇	gid ₆	gid ₅	gid ₄	gid ₃	gid ₂	gid ₁
	8	gid ₁₆	gid ₁₅	gid ₁₄	gid ₁₃	gid ₁₂	gid ₁₁	gid ₁₀	gid ₉
	9	gid ₂₄	gid ₂₃	gid ₂₂	gid ₂₁	gid ₂₀	gid ₁₉	gid ₁₈	gid ₁₇
message identifier (gmi)	10	0	0	0	0	0	1	0	0
message length (len)	11	len ₈	len ₇	len ₆	len ₅	len ₄	len ₃	len ₂	len ₁
data set length (l)	12	l ₈	l ₇	l ₆	l ₅	l ₄	l ₃	l ₂	l ₁
for N FAS data blocks (i=1 to i=N): operation type (ot) SBAS provider ID (sp)	13+(i-1)x40	sp ₄	sp ₃	sp ₂	sp ₁	ot ₄	ot ₃	ot ₂	ot ₁
airport ID (ai)	14+(i-1)x40	ai ₈	ai ₇	ai ₆	ai ₅	ai ₄	ai ₃	ai ₂	ai ₁
	15+(i-1)x40	ai ₁₆	ai ₁₅	ai ₁₄	ai ₁₃	ai ₁₂	ai ₁₁	ai ₁₀	ai ₉
	16+(i-1)x40	ai ₂₄	ai ₂₃	ai ₂₂	ai ₂₁	ai ₂₀	ai ₁₉	ai ₁₈	ai ₁₇
	17+(i-1)x40	ai ₃₂	ai ₃₁	ai ₃₀	ai ₂₉	ai ₂₈	ai ₂₇	ai ₂₆	ai ₂₅
runway number (rn) runway letter (rl)	18+(i-1)x40	rl ₂	rl ₁	rn ₆	rn ₅	rn ₄	rn ₃	rn ₂	rn ₁
approach performance designator (apd) route indicator (ri)	19+(i-1)x40	ri ₅	ri ₄	ri ₃	ri ₂	ri ₁	apd ₃	apd ₂	apd ₁
reference path data selector (rps)	20+(i-1)x40	rps ₈	rps ₇	rps ₆	rps ₅	rps ₄	rps ₃	rps ₂	rps ₁
reference path ID (rpi)	21+(i-1)x40	rpi ₈	rpi ₇	rpi ₆	rpi ₅	rpi ₄	rpi ₃	rpi ₂	rpi ₁

Description	Octet	Bit number							
		8	7	6	5	4	3	2	1
	22+(i-1)x40	rpi ₁₆	rpi ₁₅	rpi ₁₄	rpi ₁₃	rpi ₁₂	rpi ₁₁	rpi ₁₀	rpi ₉
	23+(i-1)x40	rpi ₂₄	rpi ₂₃	rpi ₂₂	rpi ₂₁	rpi ₂₀	rpi ₁₉	rpi ₁₈	rpi ₁₇
	24+(i-1)x40	rpi ₃₂	rpi ₃₁	rpi ₃₀	rpi ₂₉	rpi ₂₈	rpi ₂₇	rpi ₂₆	rpi ₂₅
LTP/FTP latitude (ltla)	25+(i-1)x40	ltla ₈	ltla ₇	ltla ₆	ltla ₅	ltla ₄	ltla ₃	ltla ₂	ltla ₁
	26+(i-1)x40	ltla ₁₆	ltla ₁₅	ltla ₁₄	ltla ₁₃	ltla ₁₂	ltla ₁₁	ltla ₁₀	ltla ₉
	27+(i-1)x40	ltla ₂₄	ltla ₂₃	ltla ₂₂	ltla ₂₁	ltla ₂₀	ltla ₁₉	ltla ₁₈	ltla ₁₇
	28+(i-1)x40	ltla ₃₂	ltla ₃₁	ltla ₃₀	ltla ₂₉	ltla ₂₈	ltla ₂₇	ltla ₂₆	ltla ₂₅
LTP/FTP longitude (ltlo)	29+(i-1)x40	ltlo ₈	ltlo ₇	ltlo ₆	ltlo ₅	ltlo ₄	ltlo ₃	ltlo ₂	ltlo ₁
	30+(i-1)x40	ltlo ₁₆	ltlo ₁₅	ltlo ₁₄	ltlo ₁₃	ltlo ₁₂	ltlo ₁₁	ltlo ₁₀	ltlo ₉
	31+(i-1)x40	ltlo ₂₄	ltlo ₂₃	ltlo ₂₂	ltlo ₂₁	ltlo ₂₀	ltlo ₁₉	ltlo ₁₈	ltlo ₁₇
	32+(i-1)x40	ltlo ₃₂	ltlo ₃₁	ltlo ₃₀	ltlo ₂₉	ltlo ₂₈	ltlo ₂₇	ltlo ₂₆	ltlo ₂₅
LTP/FTP height (lth)	33+(i-1)x40	lth ₈	lth ₇	lth ₆	lth ₅	lth ₄	lth ₃	lth ₂	lth ₁
	34+(i-1)x40	lth ₁₆	lth ₁₅	lth ₁₄	lth ₁₃	lth ₁₂	lth ₁₁	lth ₁₀	lth ₉
DFPAP latitude (fpla)	35+(i-1)x40	fpla ₈	fpla ₇	fpla ₆	fpla ₅	fpla ₄	fpla ₃	fpla ₂	fpla ₁
	36+(i-1)x40	fpla ₁₆	fpla ₁₅	fpla ₁₄	fpla ₁₃	fpla ₁₂	fpla ₁₁	fpla ₁₀	fpla ₉
	37+(i-1)x40	fpla ₂₄	fpla ₂₃	fpla ₂₂	fpla ₂₁	fpla ₂₀	fpla ₁₉	fpla ₁₈	fpla ₁₇
DFPAP longitude (fplo)	38+(i-1)x40	fplo ₈	fplo ₇	fplo ₆	fplo ₅	fplo ₄	fplo ₃	fplo ₂	fplo ₁
	39+(i-1)x40	fplo ₁₆	fplo ₁₅	fplo ₁₄	fplo ₁₃	fplo ₁₂	fplo ₁₁	fplo ₁₀	fplo ₉
	40+(i-1)x40	fplo ₂₄	fplo ₂₃	fplo ₂₂	fplo ₂₁	fplo ₂₀	fplo ₁₉	fplo ₁₈	fplo ₁₇
approach threshold crossing height (apth)	41+(i-1)x40	apth ₈	apth ₇	apth ₆	apth ₅	apth ₄	apth ₃	apth ₂	apth ₁
approach TCH units selector (aptu)	42+(i-1)x40	aptu ₁	apth ₁₅	apth ₁₄	apth ₁₃	apth ₁₂	apth ₁₁	apth ₁₀	apth ₉
glide path angle (gpa)	43+(i-1)x40	gpa ₈	gpa ₇	gpa ₆	gpa ₅	gpa ₄	gpa ₃	gpa ₂	gpa ₁
	44+(i-1)x40	gpa ₁₆	gpa ₁₅	gpa ₁₄	gpa ₁₃	gpa ₁₂	gpa ₁₁	gpa ₁₀	gpa ₉
course width (cw)	45+(i-1)x40	cw ₈	cw ₇	cw ₆	cw ₅	cw ₄	cw ₃	cw ₂	cw ₁
DLength offset (dlo)	46+(i-1)x40	dlo ₈	dlo ₇	dlo ₆	dlo ₅	dlo ₄	dlo ₃	dlo ₂	dlo ₁
FAS CRC (fc)	47+(i-1)x40	fc ₈	fc ₇	fc ₆	fc ₅	fc ₄	fc ₃	fc ₂	fc ₁
	48+(i-1)x40	fc ₁₆	fc ₁₅	fc ₁₄	fc ₁₃	fc ₁₂	fc ₁₁	fc ₁₀	fc ₉
	49+(i-1)x40	fc ₂₄	fc ₂₃	fc ₂₂	fc ₂₁	fc ₂₀	fc ₁₉	fc ₁₈	fc ₁₇
	50+(i-1)x40	fc ₃₂	fc ₃₁	fc ₃₀	fc ₂₉	fc ₂₈	fc ₂₇	fc ₂₆	fc ₂₅

Description	Octet	Bit number							
		8	7	6	5	4	3	2	1
FAS vertical alert limit /approach status (va)	51+(i-1)x40	va ₈	va ₇	va ₆	va ₅	va ₄	va ₃	va ₂	va ₁
FAS lateral alert limit/approach status (la)	52+(i-1)x40	la ₈	la ₇	la ₆	la ₅	la ₄	la ₃	la ₂	la ₁
GNS-B message CRC (gc)	53+(i-1)x40	gc ₈	gc ₇	gc ₆	gc ₅	gc ₄	gc ₃	gc ₂	gc ₁
	54+(i-1)x40	gc ₁₆	gc ₁₅	gc ₁₄	gc ₁₃	gc ₁₂	gc ₁₁	gc ₁₀	gc ₉
	55+(i-1)x40	gc ₂₄	gc ₂₃	gc ₂₂	gc ₂₁	gc ₂₀	gc ₁₉	gc ₁₈	gc ₁₇
	56+(i-1)x40	gc ₃₂	gc ₃₁	gc ₃₀	gc ₂₉	gc ₂₈	gc ₂₇	gc ₂₆	gc ₂₅
response reservation field	57+(i-1)x40	0	0	0	0	0	1	1	1
c	58+(i-1)x40	c ₉	c ₁₀	c ₁₁	c ₁₂	c ₁₃	c ₁₄	c ₁₅	c ₁₆
c	59+(i-1)x40	c ₁	c ₂	c ₃	c ₄	c ₅	c ₆	c ₇	c ₈
flag	-	0	1	1	1	1	1	1	0

7.4.3.2 Test cases

The equipment under test must be brought into the defined idle state before the performance of the individual test cases. Each test case starts in this state and leaves the equipment in that state after completion. The idle state is the state which the equipment enters after successful completion of the power up sequence. To perform several test cases in sequence the power on macro M_POWER_UP must only be executed at the beginning.

All protocol test cases shall be performed on a GSC channel (GSC1 or GSC2) unless stated otherwise in the test case itself.

Whenever a burst is specified in a test without values being given for all the parameters in a burst, and where the test does not instantiate the values, then the values of these parameters may be ignored.

If an expected test result mentioned in a test step is not observed during the execution of a test case, then the test case must be terminated and the equipment initialized before a new test case is executed. Further verification in that test case may not provide any valid results.

7.4.3.2.1 Test case macros

Test case macros shall be as defined in EN 301 842-2 [5] clause 7.4.3.2.1.

7.4.3.2.2 Test case descriptions

Test Case Name:		ADSB_request_A				
Purpose:		To demonstrate that a station which desires another station to transmit a single autonomous synchronization burst will transmit an ADS-B request burst with the sleep and auto bits set to zero.				
Context	Step	Action	PCO	Action Qualifier	Ref	Comment
preamble	1	do		M_POWER_UP.		Prepare the transceiver for testing.
test body	2	send	RF	SYNC_BURST_b (s:= add_B).	Sb	Send a sync burst from station B.
	3	send	Appln	REQUEST TO TRANSMIT ADS-B REQUEST MESSAGE (SINGLE RESPONSE, AUTONOMOUS SELECTION) TO STATION B.		Instruct station A to send an ADS-B request to station B, requesting a single response in the specified slot and autonomous selection of variable field by station B.
	4	await	RF	ADSB_REQUEST_a (s = add_A, d = add_B) transmitted by station A.	ARa	Wait for the ADS-B request to be transmitted by station A.
	5	verify	RF	For ADSB_REQUEST_a (s = add_A; d =add_B): burst is a general request with r-mi ₁ := 0; includes unicast reservation field; has burst format as defined in clause 9.2.3.4.3; sleep = 0; auto = 0.		Verify that a general request burst has been sent by station A to station B with the format in clause 9.2.3.4.3 and with sleep = 0 and auto = 0.
postamble	6					Bring test equipment into idle state.
Comments:						

Test Case Name:		ADSB_request_B				
Purpose:		To demonstrate that a station which desires another station to transmit a single autonomous synchronization burst with a specified variable part, will transmit an ADS-B request burst with sleep=0 and auto=1 and shall include the auto parameters.				
Context	Step	Action	PCO	Action Qualifier	Ref	Comment
preamble	1	do		M_POWER_UP.		Prepare the transceiver for testing.
test body	2	send	RF	SYNC_BURST_b (s:= add_B).	Sb	Send a sync burst from station B.
	3	send	Appln	REQUEST TO TRANSMIT ADS-B REQUEST MESSAGE (SINGLE RESPONSE, BASIC VARIABLE PART, GEOMETRIC ALTITUDE RATE) TO STATION B.		Instruct station A to send an ADS-B request to station B, requesting a single response, a specified variable part in the specified slot, and a specified type of altitude rate.
	4	await	RF	ADSB_REQUEST_b (s = add_A; d = add_B) sent by station A.	ARb	Wait for the ADS-B request to be transmitted by station A.
	5	verify	RF	For ADSB_REQUEST_b (s = add_A, d =add_B): burst is a general request with r-mi ₁ = 0; includes unicast reservation field; has burst format as defined in clause 9.2.3.4.3; sleep = 0; auto = 1; r-id = 0; aux = 1.		Verify that a general request burst has been sent by station A to station B with the format in clause 8.2.3.4.3 and with sleep = 0 and auto = 1. Verify that the auto parameters are included with r-id = 0 and aux = 1.
postamble	6					Bring test equipment into idle state.
Comments:						

Test Case Name:		ADSB_request_C				
Purpose:		To demonstrate that a station which desires another station to transmit synchronization bursts autonomously with the use of sleep mode, will transmit an ADS-B request burst with sleep=1 and auto=0 and shall include the sleep parameters.				
Context	Step	Action	PCO	Action Qualifier	Ref	Comment
preamble	1	do		M_POWER_UP.		Prepare the transceiver for testing.
test body	2	send	RF	SYNC_BURST_b (s:= add_B)	Sb	Send a sync burst from station B.
	3	send	Appln	REQUEST TO TRANSMIT ADS-B REQUEST MESSAGE (SLEEP MODE, AUTONOMOUS SELECTION) (snr:=15; vel:=10; pos:=100) TO STATION B.		Instruct station A to send an ADS-B request to station B, requesting sleep mode and autonomous selection of variable field by station B.
	4	await	RF	ADSB_REQUEST_c (s = add_A; d = add_B) sent by station A.	ARc	Wait for the ADS-B request to be transmitted by station A.
	5	verify	RF	For ADSB_REQUEST_c (s:= add_A; d:= add_B): burst is a general request with $r-mi_1 = 0$; includes autotune reservation field; has the burst format defined in clause 9.2.3.4.3; sleep:= 1; auto = 0; snr = 15; vel = 10; pos = 100.		Verify that a general request burst has been sent by station A to station B with the format in clause 9.2.3.4.3, with sleep = 1 and auto = 0, the sleep parameters included, and the correct values of snr, vel and pos used.
postamble	6					Bring test equipment into idle state.
Comments:						

Test Case Name:		ADSB_request_D				
Purpose:		To demonstrate that a station which desires another station to transmit synchronization bursts with a specified variable part and with the use of sleep mode, will transmit an ADS-B request burst with sleep=1 and auto=1 and shall include the auto and sleep parameters.				
Context	Step	Action	PCO	Action Qualifier	Ref	Comment
preamble	1	do		M_POWER_UP.		Prepare the transceiver for testing.
test body	2	send	RF	SYNC_BURST_b (s:= add_B).	Sb	Send a sync burst from station B.
	3	send	Appln	REQUEST TO TRANSMIT ADS-B REQUEST MESSAGE (SLEEP MODE, FULL POSITION VARIABLE PART) (snr:=6, vel:= 5, pos:= 150) TO STATION B.		Instruct station A to send an ADS-B request to station B, requesting use of sleep mode and a specified variable part in the specified slots.
	4	await	RF	ADSB_REQUEST_d (s = add_A, d = add_B) sent by station A.	ARd	Wait for the ADS-B request to be transmitted by station A.
	5	verify	RF	For ADSB_REQUEST_d (s = add_A, d =add_B): burst is a general request with r-mi ₁ = 0; includes autotune reservation field; has the burst format defined in clause 9.2.3.4.3; sleep = 1; auto = 1; r-id = 2; snr = 15; vel = 10; pos = 100.	ARd	Verify that a general request burst has been sent by station A to station B with the format in clause 9.2.3.4.3, with sleep = 1 and auto = 1, the sleep and auto parameters included and the correct values of snr, vel and pos.
postamble	6					Bring test equipment into idle state.
Comments:						

Test Case Name:		ADSB_reporting				
Purpose:		To demonstrate that a station will send at least 12 sync bursts a minute averaged over the two GSCs.				
Context	Step	Action	PCO	Action Qualifier	Ref	Comment
preamble	1	do		M_POWER_UP.		Prepare the transceiver for testing.
test body	2	rep 60		n:= 1.		Set n equal to 1.
	3	await	RF (GSC1 and GSC2)	SYNC_BURST_b (s = add_A).	Sb	Monitoring both GSC1 and GSC2, await a sync burst from station A.
	4	record	RF (GSC1 and GSC2)	time(n):= time at the beginning of slot containing SYNC_BURST_b (s = add_A).	Sb	Record the time at which each sync burst is transmitted.
	5	verify		time(n) - time(n - 1) = 5 ± 2 secs.		Verify that the bursts are transmitted about 5 s apart.
	6	endrep		n:= n + 1.		Add 1 to the value of n and repeat test on GSC1/GSC2 60 times.
	7	verify		time(60) - time(1) <= 5 mins.		Verify that averaged over the two GSCs the station emits on average at least 12 synch bursts per minute.
postamble	8					Bring test equipment into idle state.
Comments:						

Test Case Name:		ADSB_request_time				
Purpose:		To show that a station requesting the time synchronization information field (information field ID 2) shall only transmit a request to a station that has announced that it is operating with a primary time source (tfom = 0 or 1).				
Context	Step	Action	PCO	Action Qualifier	Ref	Comment
preamble	1	do		M_POWER_UP.		Prepare the transceiver for testing.
test body	2	send	RF	SYNC_BURST_b (s:= add_B; tfom:= 2).	Sb	Sync burst from station B, secondary time given.
	3	send	RF	SYNC_BURST_b (s:= add_C; tfom:= 0).	Sb	Sync burst from station C, certified primary time given.
	4	send	RF	SYNC_BURST_b (s:= add_D; tfom:= 2).	Sb	Sync burst from station D, secondary time given.
	5	send	RF	SYNC_BURST_b (s:= add_E; tfom:= 1).	Sb	Sync burst from station E, non-certified primary time given.
	6	send	RF	SYNC_BURST_b (s:= add_F; tfom:= 0).	Sb	Sync burst from station F, certified primary time given.
	7	send	Appln	REQUEST TO TRANSMIT ADS-B REQUEST MESSAGE (s:=add_A; d:=add_B; r-id:=4).		Instruct station A via the Appln PCO to send a request burst to station B requesting UTC time information field.
	8	send	Appln	REQUEST TO TRANSMIT ADS-B REQUEST MESSAGE (s:=add_A; d:=add_C; r-id:=4).		Instruct station A via the Appln PCO to send a request burst to station C requesting UTC time information field.
	9	send	Appln	REQUEST TO TRANSMIT ADS-B REQUEST MESSAGE (s:=add_A; d:=add_D; r-id:=4).		Instruct station A via the Appln PCO to send a request burst to station D requesting UTC time information field.
	10	send	Appln	REQUEST TO TRANSMIT ADS-B REQUEST MESSAGE (s:=add_A; d:=add_E; r-id:=4).		Instruct station A via the Appln PCO to send a request burst to station E requesting UTC time information field.
	11	send	Appln	REQUEST TO TRANSMIT ADS-B REQUEST MESSAGE (s:=add_A; d:=add_F; r-id:=4).		Instruct station A via the Appln PCO to send a request burst to station F requesting UTC time information field.
	12	rep 5		n:= 1.		Start loop.
13	await	RF	ADSB_REQUEST_b (s = add_A).	ARb	Wait for an ADSB request message.	
14	record	RF	DEST(n) = value of d given in ADSB_REQUEST_b (s = add_A).	ARb	Record the destination address in the ADSB request.	
15	verify	RF	DEST(n) = add_C, add_E or add_F not add_B or add_D.		Verify that requests were only sent to those that had declared primary time.	
16	endrep		n:= n + 1.		End loop.	
postamble	17				Bring test equipment into idle state.	

Comments:

Test Case Name: ADSB_priority						
Purpose: To show that information fields 0, 1, 2, 3, 4 and A1 hex have priority over other information fields.						
Context	Step	Action	PCO	Action Qualifier	Ref	Comment
preamble	1	do		M_POWER_UP.		Prepare the transceiver for testing.
	2	rep 10		n:= 1.		Set n equal to 1.
test body	3	send	Appln	REQUEST TO TRANSMIT ADS-B REQUEST MESSAGE (SINGLE RESPONSE, AUTONOMOUS SELECTION) TO STATION B.		Instruct station A to send an ADS-B request to station B, requesting a single response in the specified slot and autonomous selection of the variable field by station B.
	4	await	RF	ADSB_REQUEST_a (s:= add_A; d:= add_B) sent by station A.	ARa	Wait for the ADS-B request to be transmitted by station A.
	5	verify		r-id is equal to one of {0, 1, 2, 3, 4, A1} hex.		Show that station A chooses an information field from the set {0, 1, 2, 3, 4, A1}.
	6	end rep		n:= n + 1.		End loop.
postamble	7					Bring test equipment into idle state.
Comments:						

Test Case Name: ADSB_TCP_flag_C						
Purpose: To show that a ground station, when configured to respond in this way, will request a mobile which has transmitted a TCP/SVQ flag of zero to transmit a sync burst with a two-slot TCP or SVQ variable part.						
Context	Step	Action	PCO	Action Qualifier	Ref	Comment
preamble	1	do		M_POWER_UP.		Prepare the transceiver for testing.
test body	2	send	Appln	REQUEST TO RESPOND TO TCP/SVQ FLAG SET TO ZERO WITH ADS-B REQUEST FOR 2-SLOT TCP OR SVQ.		Configure the station under test to respond to reception of directed sync bursts with TCP/SVQ flag set to zero by issuing an ADSB request for a sync burst with 2-slot TCP or SVQ variable part.
	3	send	RF	DIR_SYNC_BURST_a (s:= add_B; tqc:= 0).	DSa	Send a directed sync burst from a simulated station B, with a basic variable part, to the station under test, with the TCP/SVQ flag set to zero.
	4	verify	RF	ADSB_Request_e (s:= add_A; d:= add_A; sleep:= 0; auto:= 1; r-id:= 8 hex or 5 hex) transmitted by station A.	ARe	Verify that the station under test sends an ADSB request burst addressed to station B, requesting transmission of a sync burst with the 2-slot TCP or SVQ variable field.
postamble	5					Bring test equipment into idle state.
Comments:						

Test Case Name: ADSB_DOS_A						
Purpose: To demonstrate that a station will broadcast a Directory of Service message with the correct format.						
Context	Step	Action	PCO	Action Qualifier	Ref	Comment
preamble	1	do		M_POWER_UP.		Prepare the transceiver for testing.
test body	2	rep x		x:={P,Q,R,S}.		Repeat test for 4 sets of parameters.
	3	send	Appln	REQUEST TO TRANSMIT DOS MESSAGE (ADSB_DOS_APPIN_PARAMETERS(x)).		Send an instruction at the Appln PCO to the station under test to transmit a DOS message.
	4	await	RF	BURST (s:= add_A) broadcast by station A.		Wait for the DOS message to be broadcast by station under test.
	5	verify	RF	BURST (s:= add_A) has the format of "CTRL_DOS_a".	CDa	Verify that the transmitted burst conforms to "CTRL_DOS_a" as set out in burst format section.
	6	verify	RF	ADSB_DOS_RF_OUT_PARAMETERS(x).		Verify that the parameters have been correctly encoded in the message.
	7	endrep		next x.		
postamble	8					Bring test equipment into idle state.
Comments:						

Test Case Name: ADSB_Channel_A						
Purpose: To demonstrate that a station will broadcast a channel management message with the correct format.						
Context	Step	Action	PCO	Action Qualifier	Ref	Comment
preamble	1	do		M_POWER_UP.		Prepare the transceiver for testing.
test body	2	rep x		x:={P,Q,R,S}.		Repeat test for 4 sets of parameters.
	3	send	Appln	REQUEST TO TRANSMIT CHANNEL MANAGEMENT MESSAGE (ADSB_CHANNEL_APPIN_PARAMETERS(x)).		Send an instruction at the Appln PCO to the station under test to transmit a channel management message including address of station B.
	4	await	RF	BURST (s:= add_A) broadcast by station A.		Wait for the channel management message to be broadcast by station under test.
	5	verify	RF	BURST (s:= add_A) has the format of "CTRL_CHAN_k".	CCK	Verify that the transmitted burst conforms to "CTRL_CHAN_k" as set out in burst format section.
	6	verify	RF	ADSB_CHANNEL_RF_OUT_PARAMETERS(x).		Verify that the parameters have been correctly encoded in the message.
	7	endrep		next x.		
postamble	8					Bring test equipment into idle state.
Comments:						

Test Case Name: ADSB_Channel_B						
Purpose: To demonstrate that a station instructed to cancel its previously issued channel management message will broadcast a channel management message with csid=15, with do pointing to the slot from which cancellation shall begin, and with other subfields the same as the original message.						
Context	Step	Action	PCO	Action Qualifier	Ref	Comment
preamble	1	do		M_POWER_UP.		Prepare the transceiver for testing.
test body	2	send	Appln	REQUEST TO TRANSMIT CHANNEL MANAGEMENT MESSAGE (s:= add_A; dt:=5; do:=100; dc:=1; csid:=1; tc:=1; fc:=1; styp:=0; sr:=6; pc:=0; sc:=0; d:= add_B; ido:= 15; id:= id1 hex; aux:= 0; b/g:= 0; f := transmit freq; sleep:= 0; auto:=0; rcv:= 0; Q1:= 10; Q4:= 2; Q2a = 150; Q2b:= 150; Q2c:= 0, Q2d:= 300; TV11min:= 4; TV11max:= 8; V11:= 0; V12:= 10; VS2:= 12; VS4 = 300; nsd:=1; txd:=0; frq:=0).		Send an instruction at the Appln PCO to the station under test to transmit a channel management message including address of station B.
	3	await	RF	CTRL_CHAN_k (s:= add_A) broadcast by station A.		Wait for the channel management message to be broadcast by station A.
	4	send	Appln	REQUEST TO CANCEL CHANNEL MANAGEMENT MESSAGE.		Send a request to the station under test via the Appln PCO to cancel the management message just sent.
	5	verify	RF	CTRL_CHAN_k (s:= add_A; dt:=5; do:=2; dc:=1; csid:=15; tc:=1; fc:=1; styp:=0; sr:=6; pc:=0; sc:=0; d:= add_B; ido:= 15; id:= id1 hex; aux:= 0; b/g:= 0; f := transmit freq; sleep:= 0; auto:=0; rcv:= 0; Q1:= 10; Q4:= 2; Q2a = 150; Q2b:= 150; Q2c:= 0, Q2d:= 300; TV11min:= 4; TV11max:= 8; V11:= 0; V12:= 10; VS2:= 12; VS4 = 300; nsd:=1; txd:=0; frq:=0).		Verify that the station under test issues a channel management message with the same parameters as before but with csid = 15 and "do" set to the minimum value possible.
postamble	6					Bring test equipment into idle state.
Comments:						

Test Case Name: ADSB_Channel_C						
Purpose: To demonstrate that a station will broadcast a channel management message with repeated script block elements with the correct format.						
Context	Step	Action	PCO	Action Qualifier	Ref	Comment
preamble	1	do		M_POWER_UP.		Prepare the transceiver for testing.
test body	2	send	Appln	REQUEST TO TRANSMIT CHANNEL MANAGEMENT MESSAGE (s:= add_A; dt:=5; do:=100; dc:=1; csid:=1; tc:=1; fc:=1; styp:=0; sr:=6; pc:=0; sc:=1; d:= add_B; ido:= 15; id:= id1 hex; aux:= 0; b/g:= 0; f := transmit freq; sleep:= 0; auto:=0; rcv:= 0; Q1:= 10; Q4:= 2; Q2a = 150; Q2b:= 150; Q2c:= 0, Q2d:= 300; TV11min:= 4; TV11max:= 8; V11:= 0; V12:= 10; VS2:= 12; VS4 = 300; nsd:=1; txd:=0; frq:=0; rpt:= 0).		Send an instruction at the Appln PCO to the station under test to transmit a channel management message including address of station B, which specifies three repeats of one script element.
	3	await	RF	CTRL_CHAN_k (s:= add_A) broadcast by station A.	Cck	Wait for the channel management message to be broadcast by station A.
	4	verify	RF	CTRL_CHAN_k (s:= add_A) does not include two consecutive repeat count octets.	Cck	Verify that the transmitted burst does not include two consecutive repeat count octets.
postamble	5					Bring test equipment into idle state.
Comments:						

Test Case Name: ADSB_Channel_D						
Purpose: To demonstrate that a station will broadcast a channel management message with a regional multicast with the correct format.						
Context	Step	Action	PCO	Action Qualifier	Ref	Comment
preamble	1	do		M_POWER_UP.		Prepare the transceiver for testing.
test body	2	rep x		x:={P,Q,R,S}.		Repeat test for 4 sets of parameters.
	3	send	Appln	REQUEST TO TRANSMIT CHANNEL MANAGEMENT MESSAGE (ADSB_CHANNEL_D_APPIN_PARAMETERS(x)).		Send an instruction at the Appln PCO to the station under test to transmit a regional multicast channel management message.
	4	await	RF	BURST (s:= add_A) broadcast by station A.		Wait for the channel management message to be broadcast by station under test.
	5	verify	RF	BURST (s:= add_A) has the format of "CTRL_CHAN_p".	CCp	Verify that the transmitted burst conforms to "CTRL_CHAN_p" as set out in burst format section.
	6	verify	RF	ADSB_CHANNEL_RF_OUT_PARAMETERS(x).		Verify that the parameters have been correctly encoded in the message.
	7	endrep		next x.		
postamble	8					Bring test equipment into idle state.
Comments:						

Test Case Name:		ADSB_Directed_Slot_A				
Purpose:		To demonstrate that a station broadcasting a channel management message with a non-zero individual offset for a destination station shall ensure that the slot referred to has been reserved using block protocols or ground quarantine.				
Context	Step	Action	PCO	Action Qualifier	Ref	Comment
preamble	1	do		M_POWER_UP.		Prepare the transceiver for testing.
test body	2	send	Appln	REQUEST TO RESERVE BLOCKS WITH SECOND FRAME RESERVATION (s:=add_B; sz:=20; vt:=6), REPEATING RESERVATION CONTINUOUSLY.		Instruct the station under test to establish on a continuous basis reserved blocks of 20 slots with the second frame reservation protocol, each reservation lasting for 6 superframes.
	3	await	RF	SECOND_BLOCK_a (s=add_A; sz=20; vt=6).	SCa	Wait for the second frame block reservation to be transmitted.
	4	send	Appln	REQUEST TO TRANSMIT CHANNEL MANAGEMENT MESSAGE (s:= add_A; dt:=5; do:=100; dc:=1; csid:=1; tc:=1; fc:=1; styp:=0; sr:=6; pc:=0; sc:=0; d:= add_B; ido:= 15; id:= id1 hex; aux:= 0; b/g:= 0; f := transmit freq; sleep:= 0; auto:=0; rcv:= 0; Q1:= 10; Q4:= 2; Q2a = 150; Q2b:= 150; Q2c:= 0, Q2d:= 300; TV11min:= 4; TV11max:= 8; V11:= 0; V12:= 10; VS2:= 12; VS4 = 300; nsd:=1; txd:=0; frq:=0).		Send an instruction at the Appln PCO to the station under test to transmit a channel management message with non-zero ido with address of station B.
	5	await	RF	CTRL_CHAN_k (s:= add_A) broadcast by station A.	Cck	Wait for the channel management message to be broadcast by station A.
	6	verify	RF	CTRL_CHAN_k (s:= add_A) sent in first five slots of UTC s.	Cck	Verify that the transmitted burst is transmitted in one of five slots that will put the slot referred to by the ido parameter within a protected block.
postamble	7					Bring test equipment into idle state.
Comments:						

Test Case Name: ADSB_Basic_Ground_A						
Purpose: To demonstrate that a station will broadcast a basic ground sync burst message with the correct format.						
Context	Step	Action	PCO	Action Qualifier	Ref	Comment
preamble	1	do		M_POWER_UP.		Prepare the transceiver for testing.
test body	2	rep x		x:={P,Q,R,S}.		Repeat test for 4 sets of parameters.
	2	send	Appln	REQUEST TO TRANSMIT BASIC GROUND SYNC BURST (ADSB_BASIC_GROUND_APPIN_PARAMETERS (x)).		Send an instruction at the Appln PCO to the station under test to transmit a basic ground sync burst.
	3	await	RF	BURST (s:= add_A) broadcast by station A.		Wait for the message to be broadcast by the station under test.
	4	verify	RF	BURST (s:= add_A) has the format of "SYNC_BASIC_GROUND_a".	BGa	Verify that the transmitted burst conforms to "SYNC_BASIC_GROUND_a" as set out in the burst format section.
	5	verify	RF	ADSB_BASIC_GROUND_RF_OUT_PARAMETER S(x).		Verify that the parameters have been correctly encoded in the message.
	6	endrep		next x.		Go to next parameter set.
postamble	7					Bring test equipment into idle state.
Comments:						

Test Case Name: ADSB.UTC.Time_A						
Purpose: To demonstrate that a station will broadcast a UTC time sync burst message with the correct format.						
Context	Step	Action	PCO	Action Qualifier	Ref	Comment
preamble	1	do		M_POWER_UP.		Prepare the transceiver for testing.
test body	2	rep x		x:={P,Q,R,S}.		Repeat test for 4 sets of parameters
	2	send	AppIn	REQUEST TO TRANSMIT A UTC TIME SYNC BURST (ADSB.UTC.TIME.APPIN.PARAMETERS(x)).		Send an instruction at the AppIn PCO to the station under test to transmit a UTC time sync burst.
	3	await	RF	BURST (s:= add_A) broadcast by station A.		Wait for the message to be broadcast by the station under test.
	4	verify	RF	BURST (s:= add_A) has the format of "SYNC.UTC.TIME_a".	SBa	Verify that the transmitted burst conforms to "SYNC.UTC.TIME_a" as set out in the burst format section.
	5	verify	RF	ADSB.UTC.TIME.RF.OUT.PARAMETERS(x).		Verify that the parameters have been correctly encoded in the message.
	6	endrep		next x.		Go to next parameter set.
postamble	7					Bring test equipment into idle state.
Comments:						

Test Case Name: ADSB.Basic.Rec_A						
Purpose: To demonstrate that a station will correctly process a received basic sync burst.						
Context	Step	Action	PCO	Action Qualifier	Ref	Comment
preamble	1	do		M_POWER_UP.		Prepare the transceiver for testing.
test body	2	rep x		x: {P, Q, R, S}.		Repeat test for 4 different sets of parameters.
	2	send	RF	SYNC_BASIC_a (ADSB_BASIC_RF_IN_PARAMETERS(x)).	SBa	Send a message to the station under test from a simulated station B.
	3	await	AppOut	SYNC_BASIC_a MESSAGE INFORMATION.	SBa	Wait for the message information to be output by the station under test at the AppOut PCO.
	4	verify	AppOut	ADSB_BASIC_APPOUT_PARAMETERS(x).		Verify that the content of the information output by the station under test at the AppOut PCO is correct.
	5	endrep		next x.		Go to next parameter set.
postamble	6					Bring test equipment into idle state.
Comments:						

Test Case Name: ADSB_High_Dynamic_Rec_A						
Purpose: To demonstrate that a station will correctly process a received high dynamic sync burst.						
Context	Step	Action	PCO	Action Qualifier	Ref	Comment
preamble	1	do		M_POWER_UP.		Prepare the transceiver for testing.
test body	2	rep x		x:= {P, Q, R, S}.		Repeat test for 4 different sets of parameters.
	2	send	RF	SYNC_HIGH_DYNAMIC_a (ADSB_HIGH_DYNAMIC_RF_IN_PARAMETERS(x)).	SHa	Send a message to the station under test from a simulated station B.
	3	await	AppOut	SYNC_HIGH_DYNAMIC_a MESSAGE INFORMATION.	SHa	Wait for the message information to be output by the station under test at the AppOut PCO.
	4	verify	AppOut	ADSB_HIGH_DYNAMIC_APPOUT_PARAMETERS(x).		Verify that the content of the information output by the station under test at the AppOut PCO is correct.
	5	endrep		next x.		Go to next parameter set.
postamble	6					Bring test equipment into idle state.
Comments:						

Test Case Name: ADSB_Full_Position_Rec_A						
Purpose: To demonstrate that a station will correctly process a received full position sync burst.						
Context	Step	Action	PCO	Action Qualifier	Ref	Comment
preamble	1	do		M_POWER_UP.		Prepare the transceiver for testing.
test body	2	rep x		x:= {P, Q, R, S}.		Repeat test for 4 different sets of parameters.
	2	send	RF	SYNC_FULL_POSITION_a (ADSB_FULL_POSITION_RF_IN_PARAMETERS(x)).	SPa	Send a message to the station under test from a simulated station B.
	3	await	AppOut	SYNC_FULL_POSITION_a MESSAGE INFORMATION.	SPa	Wait for the message information to be output by the station under test at the AppOut PCO.
	4	verify	AppOut	ADSB_FULL_POSITION_APPOUT_PARAMETERS(x).		Verify that the content of the information output by the station under test at the AppOut PCO is correct.
	5	endrep		next x.		Go to next parameter set.
postamble	6					Bring test equipment into idle state.
Comments:						

Test Case Name: ADSB_Two_Slot_TCP/SVQ_Rec_A						
Purpose: To demonstrate that a station will correctly process a received two slot TCP/SVQ message.						
Context	Step	Action	PCO	Action Qualifier	Ref	Comment
preamble	1	do		M_POWER_UP.		Prepare the transceiver for testing.
test body	2	rep x		x:= {P, Q, R, S}.		Repeat test for 4 different sets of parameters.
	2	send	RF	SYNC_TWO_SLOT_TCP/SVQ_a (ADSB_TWO_SLOT_TCP/SVQ_RF_IN_PARAMETERS(x)).	STa	Send a message to the station under test from a simulated station B.
	3	await	AppOut	SYNC_TWO_SLOT_TCP/SVQ_a MESSAGE INFORMATION.	STa	Wait for the message information to be output by the station under test at the AppOut PCO.
	4	verify	AppOut	ADSB_TWO_SLOT_TCP/SVQ_APPOUT_PARAMETERS(x).		Verify that the content of the information output by the station under test at the AppOut PCO is correct.
	5	endrep		next x.		Go to next parameter set.
postamble	6					Bring test equipment into idle state.
Comments:						

Test Case Name: ADSB_Single_Slot_TCP_Rec_A						
Purpose: To demonstrate that a station will correctly process a received single slot TCP message.						
Context	Step	Action	PCO	Action Qualifier	Ref	Comment
preamble	1	do		M_POWER_UP.		Prepare the transceiver for testing.
test body	2	rep x		x:= {P, Q, R, S}.		Repeat test for 4 different sets of parameters.
	2	send	RF	SYNC_SINGLE_SLOT_TCP_a (ADSB_SINGLE_SLOT_TCP_RF_IN_PARAMETERS(x)).	SSa	Send a message to the station under test from a simulated station B.
	3	await	AppOut	SYNC_SINGLE_SLOT_TCP_a MESSAGE INFORMATION.	SSa	Wait for the message information to be output by the station under test at the AppOut PCO.
	4	verify	AppOut	ADSB_SINGLE_SLOT_TCP_APPOUT_PARAMETERS(x).		Verify that the content of the information output by the station under test at the AppOut PCO is correct.
	5	endrep		next x.		Go to next parameter set.
postamble	6					Bring test equipment into idle state.
Comments:						

Test Case Name: ADSB_Single_Slot_SVQ_Rec_A						
Purpose: To demonstrate that a station will correctly process a received single slot SVQ message.						
Context	Step	Action	PCO	Action Qualifier	Ref	Comment
preamble	1	do		M_POWER_UP.		Prepare the transceiver for testing.
test body	2	rep x		x:= {P, Q, R, S}.		Repeat test for 4 different sets of parameters.
	2	send	RF	SYNC_SINGLE_SLOT_SVQ_a (ADSB_SINGLE_SLOT_SVQ_RF_IN_PARAMETERS(x)).	SVa	Send a message to the station under test from a simulated station B.
	3	await	AppOut	SYNC_SINGLE_SLOT_SVQ_a MESSAGE INFORMATION.	SVa	Wait for the message information to be output by the station under test at the AppOut PCO.
	4	verify	AppOut	ADSB_SINGLE_SLOT_SVQ_APPOUT_PARAMETERS(x).		Verify that the content of the information output by the station under test at the AppOut PCO is correct.
	5	endrep		next x.		Go to next parameter set.
postamble	6					Bring test equipment into idle state.
Comments:						

Test Case Name: ADSB_Aircraft_Data_Rec_A						
Purpose: To demonstrate that a station will correctly process a received aircraft data message.						
Context	Step	Action	PCO	Action Qualifier	Ref	Comment
preamble	1	do		M_POWER_UP.		Prepare the transceiver for testing.
test body	2	rep x		x:= {P, Q, R, S}.		Repeat test for 4 different sets of parameters.
	2	send	RF	SYNC_AIRCRAFT_DATA_a (ADSB_AIRCRAFT_DATA_RF_IN_PARAMETERS(x)).	SDa	Send a message to the station under test from a simulated station B.
	3	await	AppOut	SYNC_AIRCRAFT_DATA_a MESSAGE INFORMATION.	SDa	Wait for the message information to be output by the station under test at the AppOut PCO.
	4	verify	AppOut	ADSB_AIRCRAFT_DATA_APPOUT_PARAMETERS(x)		Verify that the content of the information output by the station under test at the AppOut PCO is correct.
	5	endrep		next x.		Go to next parameter set.
postamble	6					Bring test equipment into idle state.
Comments:						

Test Case Name: ADSB_High_Resolution_Rec_A						
Purpose: To demonstrate that a station will correctly process a received high resolution message.						
Context	Step	Action	PCO	Action Qualifier	Ref	Comment
preamble	1	do		M_POWER_UP.		Prepare the transceiver for testing.
test body	2	rep x		x:= {P, Q, R, S}.		Repeat test for 4 different sets of parameters.
	2	send	RF	SYNC_HIGH_RESOLUTION_a (ADSB_HIGH_RESOLUTION_RF_IN_PARAMETERS(x)).	SRa	Send a message to the station under test from a simulated station B.
	3	await	AppOut	SYNC_HIGH_RESOLUTION_a MESSAGE INFORMATION.	SRa	Wait for the message information to be output by the station under test at the AppOut PCO.
	4	verify	AppOut	ADSB_HIGH_RESOLUTION_APPOUT_PARAMETERS(x)		Verify that the content of the information output by the station under test at the AppOut PCO is correct.
	5	endrep		next x.		Go to next parameter set.
postamble	6					Bring test equipment into idle state.
Comments:						

Test Case Name:		CPR_Encode_Offset				
Purpose: To demonstrate that offset latitude and longitude positions are correctly encoded in the sync burst information fields using the CPR algorithm.						
Context	Step	Action	PCO	Action Qualifier	Ref	Comment
preamble	1	do		M_POWER_UP.		Prepare the transceiver for testing.
	2	send	VSS	SUPPRESS AUTONOMOUS SYNC BURSTS.		Suppress the autonomous sync bursts to avoid possible confliction.
	3	send	VSS	SET PARAMETERS (p:= 1).		Ensure 100 % chance of transmission on access to hasten sync burst responses following a general request.
test body	4	rep 2166		n:= 1; initialize p.		
	5	send	Position	Input to station under test: LAT(n):= 12,8557 + n × 0,163 LON(n):= -0,8150 + n × 0,163	CE(r, c)	Send test values of latitude and longitude from CPR_ENC_TABLE to the station under test.
	6	rep 135		k:= 1		
	7	do		IF LAT(n) = CPR_ENC_TABLE (k, latitude) for row k of table AND LON(n) = CPR_ENC_TABLE (k, longitude) for row k of table THEN p:= k continue with following test steps within loop using current p value ELSE go to next n bypassing all the steps before the end of the loop		
	8	endrep		k:= k + 1.		
	9	send	RF	ADSB_REQ_a (r-id:= 2 hex; s= add_B)	ADa	Send a General Request burst from a simulated station B, requesting the station under test to transmit a sync burst with a full position variable information field.
	10	await	RF	SYNC_BURST_g (s= add_A)	Sg	
	11	do		IF cprf in fixed part of SYNC_BURST_g (s= add_A) equals 0 THEN continue with following test steps within n loop ELSE exit n loop and start n loop again with n:=1		Restart n loop if for the first pair of latitude and longitude values which coincides with those in the first row of CPR_ENC_TABLE, the CPR type cprf is not zero. Note: The test values provided in the CPR_ENC_TABLE can only be used if the CPR type happens to correspond to the type for which the test values were calculated. If this is not the case when the n test loop starts for the first time, the n test loop must be restarted until this happens.
	12	verify	RF	In fixed part of SYNC_BURST_g (s= add_A): cprf = CPR_ENC_TABLE (p, cpr_type)	Sg, CE(r, c)	Verify that the encoded values of latitude, longitude, and CPR type in the sync burst from the station under test agree with the values given in CPR_ENC_TABLE.
		verify	RF	AND lat = CPR_ENC_TABLE (p, lat_enc)		
		verify	RF	AND lon = CPR_ENC_TABLE (p, lon_enc)		

Test Case Name:		CPR_Encode_Offset				
Purpose: To demonstrate that offset latitude and longitude positions are correctly encoded in the sync burst information fields using the CPR algorithm.						
Context	Step	Action	PCO	Action Qualifier	Ref	Comment
	13	verify	RF	In variable part of SYNC_BURST_g (s= add_A): pid = CPR_ENC_TABLE (p, pid_enc) AND lat6(bits 1-5) = CPR_ENC_TABLE (p, lat6(1-5)) AND lat6(bit 6) = CPR_ENC_TABLE (p, lat6(6)) AND lon6(bits 1-5) = CPR_ENC_TABLE (p, lon6(1-5)) AND lon6(bit 6) = CPR_ENC_TABLE (p, lon6(6))	Sg, CE(r, c)	Verify that the encoded values of pid, lat6, and lon6 in the variable part of the sync burst from the station under test agree with the values given in CPR_ENC_TABLE.
	14	send	RF	ADSB_REQ_a (r-id:= 1 hex; s= add_B).	ADa	Send a General Request burst from a simulated station B, requesting the station under test to transmit a sync burst with a high dynamic variable information field.
	15	await	RF	SYNC_BURST_h (s= add_A).	Sh	
	16	verify	RF	In variable part of SYNC_BURST_h (s= add_A): lat4(bits 1-3) = CPR_ENC_TABLE (p, lat4(1-3)) AND lat4(bit 4) = CPR_ENC_TABLE (p, lat4(4)) AND lon4(bits 1-3) = CPR_ENC_TABLE (p, lon4(1-3)) AND lon4(bit 4) = CPR_ENC_TABLE (p, lon4(4))	Sh, CE(r, c)	Verify that the encoded values of lat4 and lon4 in the variable part of the sync burst from the station under test agree with the values given in CPR_ENC_TABLE.
	17	send	RF	ADSB_REQ_a (r-id:= AA0 hex; s= add_B).	ADa	Send a General Request burst from a simulated station B, requesting the station under test to transmit a sync burst with a high resolution variable information field.
	18	await	RF	SYNC_BURST_i (s= add_A)	Si	
	19	verify	RF	In variable part of SYNC_BURST_i (s= add_A): lat8(bits 1-7) = CPR_ENC_TABLE (p, lat8(1-7)) AND lat8(bit 8) = CPR_ENC_TABLE (p, lat8(8)) AND lon8(bits 1-7) = CPR_ENC_TABLE (p, lon8(1-7)) AND lon8(bit 8) = CPR_ENC_TABLE (p, lon8(8))	Si, CE(r, c)	Verify that the encoded values of lat8 and lon8 in the variable part of the sync burst from the station under test agree with the values given in CPR_ENC_TABLE.
	20	endrep		n:= n + 1.		
postamble	21	send	VSS	SET PARAMETERS (p:= 64/256).		Restore to default value.
	22	send	VSS	REINSTATE AUTONOMOUS SYNC BURSTS.		Reinstate the autonomous sync bursts.
Comments:						

Test Case Name:		CPR_Decode_Offset				
Purpose: To demonstrate that offset latitude and longitude positions are correctly decoded from the sync burst information fields using the CPR algorithm.						
Context	Step	Action	PCO	Action Qualifier	Ref	Comment
preamble	1	do		M_POWER_UP.		Prepare the transceiver for testing.
	2	send	VSS	SUPPRESS AUTONOMOUS SYNC BURSTS.		Suppress the autonomous sync bursts to avoid possible confliction.
	3	send	VSS	SET PARAMETERS (G1:= 10).		Set the maximum number of missed reservations to 10.
test body	4	rep 135		n:= 1.		
	5	send	RF	SYNC_BURST_g (po:= 0; pt:= 0; s:= add_B; lat:= CPR_ENC_TABLE (n, lat_enc); lon:= CPR_ENC_TABLE (n, lon_enc); lat6(bits 1-5):= CPR_ENC_TABLE (n, lat6(1-5)); lat6(bit 6):= CPR_ENC_TABLE (n, lat6(6)); lon6(bits 1-5):= CPR_ENC_TABLE (n, lon6(1-5)) lon6(bit 6):= CPR_ENC_TABLE (n, lon6(6))).	Sg, CE(r, c)	Send a sync burst from a simulated station B with a basic variable information field. The encoded values for lat and lon in the fixed part of the burst, and for lat6 and lon6 in the variable part, are taken from row n of CPR_ENC_TABLE.
	6	await	AppOut	LAT DATA OUT, LON DATA OUT.		Wait for the received sync burst to be processed by the station under test and sent to the ADS application output.
	7	verify	AppOut	LAT DATA OUT = CPR_DEC_TABLE (n, decoded 6-bit high-res lat) AND LON DATA OUT = CPR_DEC_TABLE (n, decoded 6-bit high-res lon).	CD(r, c)	Verify that the station under test processes the data and generates the appropriate output for display to the aircrew.
	8	send	RF	SYNC_BURST_j (po:= 0; pt:= 0; s:= add_B; lat:= CPR_ENC_TABLE (n, lat_enc); lon:= CPR_ENC_TABLE (n, lon_enc); lat4(bits 1-3):= CPR_ENC_TABLE (n, lat4(1-3)); lat4(bit 4):= CPR_ENC_TABLE (n, lat4(4)); lon4(bits 1-3):= CPR_ENC_TABLE (n, lon4(1-3)) lon4(bit 4):= CPR_ENC_TABLE (n, lon4(4))).	Sj, CE(r, c)	Send a sync burst from a simulated station B with a high dynamic variable information field. The encoded values for lat and lon in the fixed part of the burst, and for pid, lat4, and lon4 in the variable part, are taken from row n of CPR_ENC_TABLE.
	9	await	AppOut	LAT DATA OUT, LON DATA OUT.		Wait for the received sync burst to be processed by the station under test and sent to the ADS application output.
	10	verify	AppOut	LAT DATA OUT = CPR_DEC_TABLE (n, decoded 4-bit high-res lat) AND LON DATA OUT = CPR_DEC_TABLE (n, decoded 4-bit high-res lon).	CD(r, c)	Verify that the station under test processes the data and generates the appropriate output for display to the aircrew.
	11	send	RF	SYNC_BURST_i (po:= 0; pt:= 0; s:= add_B; lat:= CPR_ENC_TABLE (n, lat_enc); lon:= CPR_ENC_TABLE (n, lon_enc); lat8(bits 1-7):= CPR_ENC_TABLE (n, lat8(1-7)); lat8(bit 8):= CPR_ENC_TABLE (n, lat8(8)); lon8(bits 1-7):= CPR_ENC_TABLE (n, lon8(1-7)) lon8(bit 8):= CPR_ENC_TABLE (n, lon8(8))).	Si, CE(r, c)	Send a sync burst from a simulated station B with a high resolution information field. The encoded values for lat and lon in the fixed part of the burst, and for lat8 and lon8 in the variable part, are taken from row n of CPR_ENC_TABLE.
	12	await	AppOut	LAT DATA OUT, LON DATA OUT		Wait for the received sync burst to be processed by the station under test and sent to the ADS application output.
	13	verify	AppOut	LAT DATA OUT = CPR_DEC_TABLE (n, decoded 8-bit high-res lat)	CD(r, c)	Verify that the station under test processes the data and generates the appropriate output for display to the aircrew.

Test Case Name:		CPR_Decode_Offset				
Purpose: To demonstrate that offset latitude and longitude positions are correctly decoded from the sync burst information fields using the CPR algorithm.						
Context	Step	Action	PCO	Action Qualifier	Ref	Comment
				AND LON DATA OUT = CPR_DEC_TABLE (n, decoded 8-bit high-res lon).		
	14	endrep		n:= n + 1.		
postamble	15	send	VSS	SET PARAMETERS (G1:= 3).		Restore to default value.
	16	send	VSS	REINSTATE AUTONOMOUS SYNC BURSTS.		Reinstate the autonomous sync bursts.
Comments: Not reviewed by MGS.						

Test Case Name: TIS_Manage_C						
Purpose: To demonstrate that a station will transmit management messages once in each TIS-B update period.						
Context	Step	Action	PCO	Action Qualifier	Ref	Comment
preamble	1	do		M_POWER_UP.		Prepare the transceiver for testing.
test body	2	rep 3		t:= {6, 21, 61}.		Start loop for repeat of the test with update periods of 5 s, 20 s, and 60 s.
	3	send	Appln	REQUEST TO TRANSMIT MANAGEMENT MESSAGE (s:= add_A; up:= t; tmi:= 0).		Instruct the station under test to transmit regular management messages according to the required update period.
	4	await	RF	TIS_MAN_a (s:= add_A) transmitted by station under test.	TMa	Wait for the first management message to be transmitted by the station under test.
	5	record	RF	manage_time:= time at beginning of slot in which TIS_MAN_a (s = add_A) was broadcast.	TMa	Record the time at which the management message was broadcast.
	6	rep 10		n:= 1.		Start loop to count 10 bursts.
	7	wait		time = manage_time + (n - 0,2) × (t - 1).	TMa	Wait for time t minutes less 20 % of a period.
	8	verify	RF	TIS_MAN_a received before time = manage_time + (n + 0,2) × (t - 1).	TMa	Verify that before time t minutes plus 20 % of a period, a management message has been received.
	9	endrep		n:= n+ 1.		Repeat with n incremented.
	10	endrep		next t.		Repeat with the next update period.
postamble	11					Bring test equipment into idle state.
Comments:						

Test Case Name:		TIS_Manage_B				
Purpose:		To demonstrate that the transmission of the management message for the following TIS-B period shall not be initiated before all target messages of the current TIS-B period are transmitted.				
Context	Step	Action	PCO	Action Qualifier	Ref	Comment
preamble	1	do		M_POWER_UP.		Prepare the transceiver for testing.
test body	2	rep t		t:= {6, 21, 61}.		Input update periods as 5 s, 20 s, and 60 s respectively.
	3	send	Appln	REQUEST TO TRANSMIT MANAGEMENT MESSAGE (s:= add_A; up:= t; tmi:= 0).		Instruct the station under test to transmit regular management messages according to the required update period.
	4	send	Appln	REQUEST TO TRANSMIT AIRCRAFT AIRBORNE TARGET MESSAGE (s:= add_A; tmi:= 1; tivid:= 1; tflg:= 0; rflg:= 0; adsff:=0; rlat:= 10; rlg:= 12; bar:= 1000; aflg:= 1; gsp:= 350; gtk:= 5; tag:= 1; fidflg:= 1; fidty:= 1; call:= BA1234; cat:= 2).		Instruct the station under test to transmit a target message for aircraft BA1234.
	5	send	Appln	REQUEST TO TRANSMIT AIRCRAFT AIRBORNE TARGET MESSAGE (s:= add_A; tmi:= 1; tivid:= 1; tflg:= 0; rflg:= 0; adsff:=0; rlat:= 11; rlg:= 13; bar:= 1002; aflg:= 1; gsp:= 350; gtk:= 5; tag:= 1; fidflg:= 1; fidty:= 1; call:= LH4567; cat:= 2).		Instruct the station under test to transmit a target message for aircraft LH4567.
	6	send	Appln	REQUEST TO TRANSMIT AIRCRAFT AIRBORNE TARGET MESSAGE (s:= add_A; tmi:= 1; tivid:= 1; tflg:= 0; rflg:= 0; adsff:=0; rlat:= 9; rlg:= 12; bar:= 1005; aflg:= 1; gsp:= 350; gtk:= 5; tag:= 1; fidflg:= 1; fidty:= 1; call:= AF3344; cat:= 2).		Instruct the station under test to transmit a target message for aircraft AF3344.
	7	rep 10		n:= 1.		Set n equal to 1. Repeat ten times for 10 update periods.
	8	verify	RF	TIS_MAN_a (s:= add_A) received before target messages of current period and after any target messages of the previous period.	TMa	Verify the management burst is received before the target messages of the current period, and after any target messages of the previous period.
	9	verify	RF	TIS_AC_AIR_a (s:= add_A) received for call:= BA1234.	TAa	Verify that the target message is received for aircraft BA1234.
	10	verify	RF	TIS_AC_AIR_a (s:= add_A) received for call:= LH4567.	TAa	Verify that the target message is received for aircraft LH4567.
	11	verify	RF	TIS_AC_AIR_a (s:= add_A) received for call:= AF3344.	TAa	Verify that the target message is received for aircraft AF3344.
	12	end rep		n:= n+ 1.		At the end of the loop add 1 to n.
	13	end rep		next up1.		Repeat with the next update period.
postamble	14					Bring test equipment into idle state.
Comments:						

Test Case Name:		TIS_Channel_B				
Purpose:		To demonstrate that all TIS-B targets for a single TIV are transmitted with the same update period.				
Context	Step	Action	PCO	Action Qualifier	Ref	Comment
preamble	1	do		M_POWER_UP.		Prepare the transceiver for testing.
test body	2	send	Appln	SET FREQUENCIES: Channel1:= freq1, Channel2:= freq2, Channel3:= freq3.		Set up three TIS-B channels with different frequencies.
	3	send	Appln	SET TIV COORDINATES: tivid:= 1, nvert:= 0, centre is lat:= N 50 NM, long:= 0 tivid:= 2, nvert:= 0, centre is lat:= N 50 NM, long:= E 1 NM tivid:= 3, nvert:= 0, centre is lat:= N 51 NM, long:= E 2 NM.		Set up three TIVs.
	4	send	Appln	REQUEST TO TRANSMIT AIRCRAFT AIRBORNE TARGET MESSAGE (s:= add_A; tmi:= 1; tivid:= 1; tflg:= 0; rflg:= 0; adsff:=0; rlat:= 9; rlg:= 12; bar:= 1005; gsp:= 350; gtk:= 5; tag:= 1; fidflg:= 1; fidty:= 1; call:= BA1234; cat:= 2).		Instruct the station under test to send an aircraft (airborne) target message for aircraft BA1234 in airborne TIV 1.
	5	send	Appln	REQUEST TO TRANSMIT AIRCRAFT AIRBORNE TARGET MESSAGE (s:= add_A; tmi:= 1; tivid:= 1; tflg:= 0; rflg:= 0; adsff:=0; rlat:= 10; rlg:= 12; bar:= 1000; gsp:= 350; gtk:= 5; tag:= 1; fidflg:= 1; fidty:= 1; call:= LH5678; cat:= 2).		Instruct the station under test to send an aircraft (airborne) target message for aircraft LH5678 in airborne TIV 1.
	6	send	Appln	REQUEST TO TRANSMIT AIRCRAFT AIRBORNE TARGET MESSAGE (s:= add_A; tmi:= 1; tivid:= 1; tflg:= 0; rflg:= 0; adsff:=0; rlat:= 11; rlg:= 12; bar:= 1002; gsp:= 350; gtk:= 5; tag:= 1; fidflg:= 1; fidty:= 1; call:= AF3344; cat:= 2).		Instruct the station under test to send an aircraft (airborne) target message for aircraft AF3344 in airborne TIV 1.
	7	send	Appln	REQUEST TO TRANSMIT AIRCRAFT AIRBORNE TARGET MESSAGE (s:= add_A; tmi:= 1; tivid:= 2; tflg:= 0; rflg:= 0; adsff:=0; rlat:= 9; rlg:= 12; bar:= 1005; gsp:= 350; gtk:= 5; tag:= 1; fidflg:= 1; fidty:= 1; call:= BD4444; cat:= 2).		Instruct the station under test to send an aircraft (airborne) target message for aircraft BD4444 in airborne TIV 2.
	8	send	Appln	REQUEST TO TRANSMIT AIRCRAFT AIRBORNE TARGET MESSAGE (s:= add_A; tmi:= 1; tivid:= 2; tflg:= 0; rflg:= 0; adsff:=0; rlat:= 10; rlg:= 12; bar:= 1000; gsp:= 350; gtk:= 5; tag:= 1; fidflg:= 1; fidty:= 1; call:= AA2222; cat:= 2).		Instruct the station under test to send an aircraft (airborne) target message for aircraft AA2222 in airborne TIV 2.
	9	send	Appln	REQUEST TO TRANSMIT AIRCRAFT AIRBORNE TARGET MESSAGE (s:= add_A; tmi:= 1; tivid:= 2; tflg:= 0; rflg:= 0; adsff:=0; rlat:= 11; rlg:= 12; bar:= 1002; gsp:= 350; gtk:= 5; tag:= 1; fidflg:= 1; fidty:= 1; call:= TV3333; cat:= 2).		Instruct the station under test to send an aircraft (airborne) target message for aircraft TV3333 in airborne TIV 2.

Test Case Name:		TIS_Channel_B				
Purpose: To demonstrate that all TIS-B targets for a single TIV are transmitted with the same update period.						
Context	Step	Action	PCO	Action Qualifier	Ref	Comment
	10	send	Appln	REQUEST TO TRANSMIT AIRCRAFT GROUND TARGET MESSAGE (s:= add_A; tmi:= 2; tivid:=3; tflg:= 0; rflg:= 0; adsff:= 0; fidflg:= 1; rlat:= 9; rlg:= 12,5; gsp:=350; gtk:= 5; tag:=1; fidty:= 1; call:= BD2222; cat:=2)		Instruct the station under test to send an aircraft (ground) target message for aircraft BD2222 in ground TIV 3.
	11	send	Appln	REQUEST TO TRANSMIT AIRCRAFT GROUND TARGET MESSAGE (s:= add_A; tmi:= 2; tivid:=3; tflg:= 0; rflg:= 0; adsff:= 0; fidflg:= 1; rlat:= 10; rlg:= 12,5; gsp:=350; gtk:= 5; tag:=1; fidty:= 1; call:= KL1000; cat:=2).		Instruct the station under test to send an aircraft (ground) target message for aircraft KL1000 in ground TIV 3.
	12	send	Appln	REQUEST TO TRANSMIT AIRCRAFT GROUND TARGET MESSAGE (s:= add_A; tmi:= 2; tivid:=3; tflg:= 0; rflg:= 0; adsff:= 0; fidflg:= 1; rlat:= 11; rlg:= 12,5; gsp:=350; gtk:= 5; tag:=1; fidty:= 1; call:= NZ6666; cat:=2).		Instruct the station under test to send an aircraft (ground) target message for aircraft NZ6666 in ground TIV 3.
	13	send	Appln	REQUEST TO TRANSMIT GROUND VEHICLE MESSAGE (s:= add_A; tmi:= 3; tivid:= 3; tid:= 1000; rflg:= 0; adsff:= 0; tag:= 2; rlat:= 9; rlg:= 12; gtk:= 5; gsp:= 10).		Instruct the station under test to send a ground vehicle message for vehicle 1000 in ground TIV 3.
	14	send	Appln	REQUEST TO TRANSMIT GROUND VEHICLE MESSAGE (s:= add_A; tmi:= 3; tivid:= 3; tid:= 1001; rflg:= 0; adsff:= 0; tag:= 2; rlat:= 10; rlg:= 12; gtk:= 6; gsp:= 10).		Instruct the station under test to send a ground vehicle message for vehicle 1001 in ground TIV 3.
	15	send	Appln	REQUEST TO TRANSMIT GROUND VEHICLE MESSAGE (s:= add_A; tmi:= 3; tivid:=3; tid:= 1002; rflg:= 0; adsff:= 0; tag:= 2; rlat:= 11; rlg:= 12; gtk:= 6; gsp:= 10).		Instruct the station under test to send a ground vehicle message for vehicle 1002 in ground TIV 3.
	16	await	RF	TIS_MAN_a (s:= add_A; tivid:=1).	TMa	Await the management burst for the TIV 1.
	17	record	RF	timeMAN(n):= time at the beginning of the slot containing TIS_MAN_a (s:= add_A; tivid:=1).	TMa	Record a reference time.
	18	rep 10		n:= 1.		Repeat ten times
	19	record	RF	timeBA(n):= time at the beginning of the slot containing TIS_AC_AIR_a (s:= add_A; tivid:=1; call:= BA1234).	TAa	Record the time of the aircraft airborne burst for BA1234.
	20	record	RF	timeLH(n):= time at the beginning of the slot containing TIS_AC_AIR_a (s:= add_A; tivid:=1; call:= LH5678).	TAa	Record the time of the aircraft airborne burst for LH5678.
	21	record	RF	timeAF(n):= time at the beginning of the slot containing TIS_AC_AIR_a (s:= add_A; tivid:=1; call:= AF3344).	TAa	Record the time of the aircraft airborne burst for AF3344.

Test Case Name:		TIS_Channel_B				
Purpose:		To demonstrate that all TIS-B targets for a single TIV are transmitted with the same update period.				
Context	Step	Action	PCO	Action Qualifier	Ref	Comment
	22	verify		For $n > 1$: timeBA(n) - timeBA(n - 1) = timeLH(n) - timeLH(n - 1) = timeAF(n) - timeAF(n - 1).		Verify that the target messages pertaining to a particular (airborne) TIV are sent with the same update period.
	23	endrep		$n := n + 1$.		
	24	await	RF	TIS_MAN_a (s:= add_A; tivid:=2).	TMa	Await the management burst for the TIV 2.
	25	record	RF	timeMAN(n):= time at the beginning of the slot containing TIS_MAN_a (s:= add_A; tivid:=2).	TMa	Record a reference time.
	26	rep 10		$n := 1$.		Repeat ten times
	27	record	RF	timeBD(n):= time at the beginning of the slot containing TIS_AC_AIR_a (s:= add_A; tivid:=2; call:= BD4444).	TAa	Record the time of the aircraft airborne burst for BD4444.
	28	record	RF	timeAA(n):= time at the beginning of the slot containing TIS_AC_AIR_a (s:= add_A; tivid:=2; call:= AA2222).	TAa	Record the time of the aircraft airborne burst for AA2222.
	29	record	RF	timeTV(n):= time at the beginning of the slot containing TIS_AC_AIR_a (s:= add_A; tivid:=2; call:= TV3333).	TAa	Record the time of the aircraft airborne burst for TV3333.
	30	verify		For $n > 1$: timeBD(n) - timeBD(n - 1) = timeAA(n) - timeAA(n - 1) = timeTV(n) - timeTV(n - 1).		Verify that the target messages pertaining to a particular (airborne) TIV are sent with the same update period.
	31	endrep		$n := n + 1$.		
	32	await	RF	TIS_MAN_a (s:= add_A; tivid:=3).	TMa	Await the management burst for the TIV 3.
	33	record	RF	timeMAN(n):= time at the beginning of the slot containing TIS_MAN_a (s:= add_A; tivid:=3).	TMa	Record a reference time.
	34	rep 10		$n := 1$.		Repeat ten times
	35	record	RF	timeBD(n):= time at the beginning of the slot containing TIS_AC_GRD_a (s:= add_A; tivid:=3; call:= BD2222).	TGa	Record the time of the aircraft airborne burst for BD2222.
	36	record	RF	timeKL(n):= time at the beginning of the slot containing TIS_AC_GRD_a (s:= add_A; tivid:=3; call:= KL1000).	TGa	Record the time of the aircraft airborne burst for KL1000.
	37	record	RF	timeNZ(n):= time at the beginning of the slot containing TIS_AC_GRD_a (s:= add_A; tivid:=3; call:= NZ6666).	TGa	Record the time of the aircraft airborne burst for NZ6666.
	38	record	RF	time1000(n):= time at the beginning of the slot containing TIS_GRD_VEH_a (s:= add_A; tivid:=3; tid:= 1000).	TVa	Record the time of the aircraft airborne burst for vehicle 1000.
	39	record	RF	time1001(n):= time at the beginning of the slot containing TIS_GRD_VEH_a (s:= add_A; tivid:=3; tid:= 1001).	TVa	Record the time of the aircraft airborne burst for vehicle 1001.

Test Case Name:		TIS_Channel_B				
Purpose: To demonstrate that all TIS-B targets for a single TIV are transmitted with the same update period.						
Context	Step	Action	PCO	Action Qualifier	Ref	Comment
	40	record	RF	time1002(n):= time at the beginning of the slot containing TIS_GRD_VEH_a (s:= add_A; tivid:=3; tid:= 1002).	TVa	Record the time of the aircraft airborne burst for vehicle 1002.
	41	verify		For n>1: timeBD(n) - timeBD(n - 1) = timeKL(n) - timeKL(n - 1) = timeNZ(n) - timeNZ(n - 1) = time1000(n) - time1000(n - 1) = time1001(n) - time1001(n - 1) = time1002(n) - time1002(n - 1).		Verify that the target messages pertaining to a particular (ground) TIV are sent with the same update period.
	42	endrep		n:= n + 1.		
postamble	43					Bring test equipment into idle state.
Comments:						

Test Case Name: TIS_Target_Update_A						
Purpose: To demonstrate that each airborne target message is sent once every update period for each airborne TIV the target is included in.						
Context	Step	Action	PCO	Action Qualifier	Ref	Comment
preamble	1	do		M_POWER_UP.		Prepare the transceiver for testing.
test body	2	rep 3		t:= {6, 21, 61}.		Start loop for repeat of the test with update periods of 5 s, 20 s, and 60 s.
	3	send	AppIn	SET UPDATE PERIOD: up:= t.		Input the update period for management and target messages into the station under test.
	4	send	AppIn	SET TIV COORDINATES: (airborne) tivid:= 1, nvert:= 0, centre is lat:= N 51 NM, long:= E 7,6 NM (airborne) tivid:= 2, nvert:= 0, centre is lat:= N 50,9 NM, long:= E 6,9 NM.		Setup two airborne TIVs that overlap so that an aircraft can be in both TIVs.
	5	send	AppIn	REQUEST TO TRANSMIT AIRCRAFT AIRBORNE TARGET WITH COORDINATES: lat:= N 51 NM; long:= E 7 NM.		Input to the station under test the coordinates of an airborne target that is within both TIVs.
	6	await	RF	TIS_MAN_a (s:= add_A) transmitted by station under test.	TMa	Wait for the first management message to be transmitted by the station under test.
	7	record	RF	manage_time:= time at beginning of slot in which TIS_MAN_a (s = add_A) was broadcast.	TMa	Record the time at which the management message was broadcast.
	8	rep 10		n:= 1.		Start loop to repeat 10 times.
	9	verify	RF	TIS_AC_AIR_a (s:= add_A; tivid:= 1) received before time:= manage_time + n × (t - 1).	TAa	Verify that the target message for the aircraft broadcast by the station under test for TIV 1 is received before the end of the current report period.
	10	verify	RF	TIS_AC_AIR_a (s:= add_A; tivid:= 2) received before time:= manage_time + n × (t - 1).	TAa	Verify that the target message for the aircraft broadcast by the station under test for TIV 2 is received before the end of the current report period.
	11	endrep		n:= n + 1.		End loop.
	12	endrep		next t.		Repeat with next value of t.
postamble	13					Bring test equipment into idle state.
Comments: Still confused by the "t - 1".						

Test Case Name: TIS_Target_Update_B						
Purpose: To demonstrate that each aircraft ground target message is sent once every update period for each ground TIV the target is included in.						
Context	Step	Action	PCO	Action Qualifier	Ref	Comment
preamble	1	do		M_POWER_UP		Prepare the transceiver for testing.
test body	2	rep 3		t:= {6, 21, 61}		Start loop for repeat of the test with update periods of 5 s, 20 s, and 60 s.
	3	send	AppIn	SET UPDATE PERIOD: up:= t.		Input the update period for management and target messages into the station under test. Update period equals once per 60 s.
	4	send	AppIn	SET TIV COORDINATES: (ground) tivid:= 1, nvert:= 0, centre is lat:= N 51 NM, long:= E 7,6 NM (ground) tivid:= 2, nvert:= 0, centre is lat:= N 50,9 NM, long:= E 6,9 NM.		Setup two TIVs that overlap so that an aircraft can be in both TIVs.
	5	send	AppIn	REQUEST TO TRANSMIT AIRCRAFT GROUND TARGET WITH COORDINATES: lat:= N 51 NM; long:= E 7 NM.		Input to the station under test the coordinates of an aircraft ground target that is within both TIVs.
	6	await	RF	TIS_MAN_a (s:= add_A) transmitted by station under test.	TMa	Wait for the first management message to be transmitted by the station under test.
	7	record	RF	manage_time:= time at beginning of slot in which TIS_MAN_a (s = add_A) was broadcast.	TMa	Record the time at which the management message was broadcast.
	8	rep 10		n:= 1.		Start loop to repeat 10 times.
	9	verify	RF	TIS_AC_GRD_a (s:= add_A; tivid:= 1) received before time:= manage_time + n × (t - 1).	TGa	Verify that the target message for the aircraft broadcast by the station under test for TIV 1 is received before the end of the current report period.
	10	verify	RF	TIS_AC_GRD_a (s:= add_A; tivid:= 2) received before time:= manage_time + n × (t - 1).	TGa	Verify that the target message for the aircraft broadcast by the station under test for TIV 2 is received before the end of the current report period.
	11	endrep		n:= n+1.		End loop.
	12	endrep		next t.		Repeat with next value of t.
postamble	13					Bring test equipment into idle state.
Comments:						

Test Case Name: TIS_Target_Update_C						
Purpose: To demonstrate that each ground vehicle target message is sent once every update period for each ground TIV the target is included in.						
Context	Step	Action	PCO	Action Qualifier	Ref	Comment
preamble	1	do		M_POWER_UP.		Prepare the transceiver for testing.
test body	2	rep 3		t:= {6, 21, 61}.		Start loop for repeat of the test with update periods of 5 s, 20 s and 60 s.
	3	send	AppIn	SET UPDATE PERIOD: up:= t.		Input the update period for management and target messages into the station under test. Update period equals once per 60 s.
	4	send	AppIn	SET TIV COORDINATES: tivid:= 1, nvert:= 0, centre is lat:= N 51 NM, long:= E 7,6 NM tivid:= 2, nvert:= 0, centre is lat:= N 50,9 NM, long:= E 6,9 NM.		Setup two TIVs that overlap so that an aircraft can be in both TIVs.
	5	send	AppIn	REQUEST TO TRANSMIT GROUND VEHICLE TARGET WITH COORDINATES: lat:= N 51 NM; long:= E 7 NM.		Input to the station under test the coordinates of a ground vehicle target that is within both TIVs.
	6	await	RF	TIS_MAN_a (s:= add_A) transmitted by station under test.	TMa	Wait for the first management message to be transmitted by the station under test.
	7	record	RF	manage_time:= time at beginning of slot in which TIS_MAN_a (s = add_A) was broadcast.	TMa	Record the time at which the management message was broadcast.
	8	rep 10		n:= 1.		Start loop to repeat 10 times.
	9	verify	RF	TIS_GRD_VEH_a (s:= add_A; tidid:= 1) received before time:= manage_time + n × (t - 1).	TVa	Verify that the target message for the aircraft broadcast by the station under test for TIV 1 is received before the end of the current report period.
	10	verify	RF	TIS_GRD_VEH_a (s:= add_A; tidid:= 2) received before time:= manage_time + n × (t - 1).	TVa	Verify that the target message for the aircraft broadcast by the station under test for TIV 2 is received before the end of the current report period.
	11	endrep		n:= n + 1.		End loop.
	12	endrep		next t.		Repeat with next value of t.
postamble	13					Bring test equipment into idle state.
Comments:						

Test Case Name:		TIS_Target_Update_D				
Purpose:		To demonstrate that each aircraft ground target message is sent once every update period for each ground and airborne TIV the target is included in.				
Context	Step	Action	PCO	Action Qualifier	Ref	Comment
preamble	1	do		M_POWER_UP.		Prepare the transceiver for testing.
test body	2	rep 3		t:= {6, 21, 61}.		Start loop for repeat of the test with update periods of 5 s, 20 s and 60 s.
	3	send	Appln	SET UPDATE PERIOD: up:= t.		Input the update period for management and target messages into the station under test. Update period equals once per 60 s.
	4	send	Appln	SET TIV COORDINATES: (ground) tivid:= 1, nvert:= 0, centre is lat:= N 51 NM, long:= E 7,6 NM (airborne) tivid:= 2, nvert:= 0, centre is lat:= N 50,9 NM, long:= E 6,9 NM.		Setup two TIVs that overlap so that an aircraft can be in both TIVs, one TIV being a ground TIV and the other an airborne TIV.
	5	send	Appln	REQUEST TO TRANSMIT AIRCRAFT GROUND TARGET WITH COORDINATES: lat:= N 51 NM; long:= E 7 NM.		Input to the station under test the coordinates of an aircraft ground target that is within both TIVs.
	6	await	RF	TIS_MAN_a (s:= add_A) transmitted by station under test.	TMa	Wait for the first management message to be transmitted by the station under test.
	7	record	RF	manage_time:= time at beginning of slot in which TIS_MAN_a (s = add_A) was broadcast.	TMa	Record the time at which the management message was broadcast.
	8	rep 10		n:= 1.		Start loop to repeat 10 times.
	9	verify	RF	TIS_AC_GRD_a (s:= add_A; tivid:= 1) received before time:= manage_time + n × (t - 1).	TGa	Verify that the target message for the aircraft broadcast by the station under test for TIV 1 is received before the end of the current report period.
	10	verify	RF	TIS_AC_GRD_a (s:= add_A; tivid:= 2) received before time:= manage_time + n × (t - 1).	TGa	Verify that the target message for the aircraft broadcast by the station under test for TIV 2 is received before the end of the current report period.
	11	endrep		n:= n+1.		End loop.
	12	endrep		next t.		Repeat with next value of t.
postamble	13					Bring test equipment into idle state.
Comments:						

Test Case Name:		TIS_Target_Ground				
Purpose:		To demonstrate that for a ground TIV, appropriate target messages are broadcast depending on whether they are identified as either aircraft or ground vehicles.				
Context	Step	Action	PCO	Action Qualifier	Ref	Comment
preamble	1	do		M_POWER_UP		Prepare the transceiver for testing.
test body	2	send	Appln	SET TIV COORDINATES: (airborne) tivid:= 1; nvert:= 0; centre is lat:= N 51 NM; long:= E 7,6 NM (ground) tivid:= 2; nvert:= 0; centre is lat:= N 50,9 NM; long:= E 6,9 NM.		Setup two TIVs that overlap so that an aircraft can be in both TIVs.
	3	send	Appln	REQUEST TO TRANSMIT AIRCRAFT AIRBORNE TARGETS WITH COORDINATES: AIRCRAFT A: lat:= N 50,6 NM; lng:= E 4,5 NM AIRCRAFT B: lat:= N 53 NM; lng:= E 4,6 NM AIRCRAFT C: lat:= N 52,9 NM; lng:= E 7 NM.		Input target data from three aircraft (airborne).
	4	send	Appln	REQUEST TO TRANSMIT AIRCRAFT GROUND TARGETS WITH COORDINATES: AIRCRAFT D: lat:= N 51 NM; lng:= E 7,6 NM AIRCRAFT E: lat:= N 51,5 NM; lng:= E 6,7 NM AIRCRAFT F: lat:= N 51,8 NM; lng:= E 7,7 NM.		Input target data from three aircraft on the ground (within both a ground TIV and an airborne TIV at the same time).
	5	send	Appln	REQUEST TO TRANSMIT GROUND VEHICLE TARGETS WITH COORDINATES: VEHICLE G: lat:= N 53 NM; lng:= E 5,9 NM VEHICLE H: lat:= N 52,3 NM; lng:= E 7,2 NM VEHICLE I: lat:= N 50,9 NM; lng:= E 6,7 NM.		Input target data from three ground vehicles to the station under test.
	6	rep 3		n:= {A, B, C}.		Repeat for different aircraft.
	7	await	RF	TARGET MESSAGE FOR AIRBORNE AIRCRAFT n.		Wait for a target message for the airborne aircraft.
	8	verify	RF	TARGET MESSAGE FOR AIRBORNE AIRCRAFT n HAS FORMAT TIS_AC_AIR_a (s:= add_A; tivid = 1) (16 bits assigned to rlat, 16 bits assigned to rlg).	TAa	Show that the target messages for the airborne aircraft are the correct aircraft airborne target messages with the 16-bit resolution for latitude and longitude.
	9	end rep		next n.		End loop.
	10	rep 2		tiv := { 1, 2}.		Repeat for both TIVs.
	11	rep 3		n:= {D, E, F}.		Repeat for different aircraft.
	12	await	RF	TARGET MESSAGE FOR GROUND AIRCRAFT n.		Wait for a target message for the aircraft on ground.
	13	verify	RF	TARGET MESSAGE FOR GROUND AIRCRAFT n HAS FORMAT TIS_AC_GRD_a (s:= add_A; tivid = tiv) (20 bits assigned to rlat, 20 bits assigned to rlg).	TGa	Show that the target messages for the aircraft on ground are the correct aircraft ground target messages with the 20-bit resolution for latitude and longitude.
	14	end rep		next n.		End loop.
	15	end rep		next tiv.		Select the next value of tivid and repeat.
	16	rep 3		n:= {G, H, I}.		Repeat for different vehicles.
	17	await	RF	TARGET MESSAGE FOR GROUND VEHICLE n.		Wait for a target message for the ground vehicle.

Test Case Name: TIS_Target_Ground						
Purpose: To demonstrate that for a ground TIV, appropriate target messages are broadcast depending on whether they are identified as either aircraft or ground vehicles.						
Context	Step	Action	PCO	Action Qualifier	Ref	Comment
	18	verify		TARGET MESSAGE FOR GROUND VEHICLE n HAS FORMAT TIS_GRD_VEH_a (s = add_A; tivid = 2) (20 bits assigned to rlat, 20 bits assigned to rlg).	TVa	Show that the target messages for the ground vehicles are the correct ground vehicle target messages with the 20-bit resolution for latitude and longitude.
	19	end rep		next n.		End loop.
postamble	20					Bring test equipment into idle state.
Comments:						

Test Case Name: TIS_Manage_A						
Purpose: To demonstrate that a station will broadcast a management message with the correct format.						
Context	Step	Action	PCO	Action Qualifier	Ref	Comment
preamble	1	do		M_POWER_UP.		Prepare the transceiver for testing.
test body	2	rep x		x:={P,Q,R,S}.		Repeat test for 4 sets of parameters.
	3	send	AppIn	REQUEST TO TRANSMIT TIS_MANAGE_A (TIS_MANAGE_APPIN_PARAMETERS(x)).		Send an instruction at the App In PCO to the station under test to transmit a TIS-B management message.
	4	await	RF	BURST (s:= add_A) broadcast by station under test .		Wait for the management message to be broadcast by station under test.
	5	verify	RF	BURST (s:= add_A) has the format of "TIS_MAN_a".	TMa	Verify that the transmitted burst is the same as "TIS_MANAGE_a" set out in burst format section.
	6	verify	RF	TIS_MANAGE_RF_OUT_PARAMETERS(x).		Verify that the content of the information output by station under test at the RF PCO is correct.
	7	endrep		next x.		
postamble	8					Bring test equipment into idle state.
Comments: Not yet reviewed by MGS. Inserted bring test equipment back to its idle state line, maybe not necessary.						

Test Case Name:		TIS_Aircraft_Air_A				
Purpose:		To demonstrate that a station will broadcast an aircraft target message (airborne TIV) with the correct format.				
Context	Step	Action	PCO	Action Qualifier	Ref	Comment
preamble	1	do		M_POWER_UP.		Prepare the transceiver for testing.
test body	2	rep x		x:={P,Q,R,S}.		Repeat test for 4 sets of parameters.
	3	send	AppIn	REQUEST TO TRANSMIT TIS_AIRCRAFT_AIR_A (TIS_AIRCRAFT_AIR_APPIN_PARAMETERS(x)).		Send an instruction at the App In PCO to the station under test to transmit an aircraft target message (airborne service). Inclusion of "fidty" and "call" information here does not imply these parameters will necessarily be broadcast.
	4	await	RF	BURST (s:= add_A) broadcast by station A.		Wait for the target message to be broadcast by station under test.
	5	verify	RF	BURST (s:= add_A) has the format of "TIS_AC_AIR_a".	TAa	Verify that the transmitted burst is the same as "TIS_AIRCRAFT_AIR_A" set out in burst format section.
	6	verify	RF	TIS_AIRCRAFT_AIR_RF_OUT_PARAMETERS(x)		Verify that the content of the information output by station under test at the RF PCO is correct.
	7	end rep		next x.		
postamble	8					Bring test equipment into idle state.
Comments:						

Test Case Name:		TIS_Flight_ID_A				
Purpose: To demonstrate that the flight ID for a target shall be transmitted every 3 TIS-B update periods or better.						
Context	Step	Action	PCO	Action Qualifier	Ref	Comment
preamble	1	do		M_POWER_UP.		Prepare the transceiver for testing.
test body	2	send	Appln	SET UPDATE PERIOD:= once every s.		Define the update period.
	3	send	Appln	REQUEST TO TRANSMIT AIRCRAFT AIRBORNE TARGET MESSAGE (s:= add_A; tivid:= 1; tflg:= 0; rflg:= 0; adsff:= 0; tid:= 1100 10 000 000 111 001 100 101; rlat:= 50N; rlg:= 3E; bar:= 1000; aflg:= 0; gsp:= 400; gtk:= 100; tag:= 3; fidty:= 1; call:= BA1234; cat:= 2).		Send an instruction at the App In PCO to the station under test to transmit an aircraft target message (airborne service). Inclusion of "fidty" and "call" information here does not imply these parameters will necessarily be broadcast.
	4	rep 15		n:= 1; flightid:= 0.		Start loop. Set initial variables.
	5	await	RF	TIS_AC_AIR_a (s:= add_A)	TAa	Wait for the target message to be broadcast by station A.
	7	record	RF	IF call:= BA1234 IS INCLUDED IN TIS_AC_AIR_a (s:= add_A) THEN flightid:= flightid+ 1.		Record the number of times the flight ID is included.
	8	end rep		n:= n + 1		End loop.
	9	verify		flightid ≥ 5.		Verify that the flight ID is transmitted at least once every 3 update periods.
	10	send	Appln	REQUEST TO TRANSMIT AIRCRAFT GROUND TARGET MESSAGE (s:= add_A; tivid:= 1; tflg:= 0; rflg:= 0; adsff:= 0; tid:= 1100 10 000 000 111 001 100 101; rlat:= 50N; rlg:= 3E; gsp:= 400; gtk:= 100; tag:= 3; fidty:= 1; call:= BA1234; cat:= 2).		Send an instruction at the App In PCO to the station under test to transmit an aircraft target message (ground service). Inclusion of "fidty" and "call" information here does not imply these parameters will necessarily be broadcast.
	11	rep 15		n:= 1, flightid:= 0.		Start loop. Set initial variables.
	12	await	RF	TIS_AC_GRD_a (s:= add_A).	TGa	Wait for the target message to be broadcast by station A.
	14	record	RF	IF call:= BA1234 IS INCLUDED IN TIS_AC_GRD_a (s:= add_A) THEN flightid:= flightid+ 1.		Record the number of times the flight ID is included.
	15	end rep		n:= n + 1.		End loop.
	16	verify		flightid ≥ 5.		Verify that the flight ID is transmitted at least once every 3 update periods.
postamble	17					Bring test equipment into idle state.
Comments:						

Test Case Name:		TIS_Flight_ID_B				
Purpose:		To demonstrate that if more than 1 flight ID is sent, then this will be alternated for the target in question.				
Context	Step	Action	PCO	Action Qualifier	Ref	Comment
preamble	1	do		M_POWER_UP.		Prepare the transceiver for testing.
test body	2	send	Appln	update period:= 2 s.		define update period.
	3	send	Appln	REQUEST TO TRANSMIT AIRCRAFT AIRBORNE TARGET MESSAGE (s:= add_A; tivid:= 1; tflg:= 0; rflg:= 0; adsff:= 0; tid:= 1100 10 000 000 111 001 100 101; rlat:= 50N; rlg:= 3E; bar:= 1000; aflg:= 0; gsp:= 400; gtk:= 100; tag:= 3; fidflg:= 1; fidty:= 1; call:= BA1234; tailno:= 654321; cat:= 2).		Send an instruction at the App In PCO to the station under test to transmit an aircraft target message (airborne service), with two types of flight ID (callsign and tailnumber).
	4	rep 30		n:=1; calltid:= 0; tailid:= 0; callflag:= false; tailflag:= false.		Start loop. Set initial variables.
	5	await	RF	TIS_AC_AIR_a (s:= add_A).	TAa	Wait for the target message to be broadcast by station A.
	7	record		IF callflag:= false AND call:= BA1234 IS INCLUDED IN TIS_AC_AIR_a THEN callid:= callid+ 1 callflag:= true tailflag:= false ELSE IF tailflag:= false AND tailno:= 654321 IS INCLUDED IN TIS_AC_AIR_a THEN tailid:= tailid + 1 tailflag:= true callflag:= false.	TAa	Record the number of times the call sign and the tail number are transmitted alternately.
	8	end rep		n:= n + 1.		End loop.
	9	verify		callid ≥ 5 AND tailid ≥ 5.		Verify that the Flight ID is transmitted at least once every 3 update periods, and that the flight ID is alternated.
	10	send	Appln	REQUEST TO TRANSMIT AIRCRAFT GROUND TARGET MESSAGE (s:= add_A; tivid:= 1; tflg:= 0; rflg:= 0; adsff:= 0; tid:= 1100 10 000 000 111 001 100 101; rlat:= 50N; rlg:= 3E; gsp:= 400; gtk:= 100; tag:= 3; fidflg:= 1; fidty:= 1; call:= BA1234; tailno:= 654321; cat:= 2).	TGa	Send an instruction at the App In PCO to the station under test to transmit an aircraft target message (ground service) with two types of flight ID (callsign and tailnumber).
	11	rep 15		n:=1; calltid:= 0; tailid:= 0; callflag:= false; tailflag:= false.		Start loop. Set initial variables.
	12	await	RF	TIS_AC_GRD_a (s:= add_A).	TGa	Wait for the target message to be broadcast by station A.
	14	record		IF callflag:= false AND call:= BA1234 IS INCLUDED IN TIS_AC_GRD_a THEN callid:= callid+ 1 callflag:= true tailflag:= false ELSE IF tailflag:= false AND tailno:= E7654321 THEN tailid:= tailid + 1	TGa	Record the number of times the call sign and the tail number are transmitted alternately.

Test Case Name: TIS_Flight_ID_B						
Purpose: To demonstrate that if more than 1 flight ID is sent, then this will be alternated for the target in question.						
Context	Step	Action	PCO	Action Qualifier	Ref	Comment
				tailflag:= true callflag:= false.		
	15	end rep		n:= n + 1.		End loop.
	16	verify		callid ≥ 5 AND tailid ≥ 5.		Verify that the Flight ID is transmitted at least once every 3 update periods, and that the flight ID is alternated.
postamble	17					Bring test equipment into idle state.
Comments:						

Test Case Name: TIS_Aircraft_Grd_A						
Purpose: To demonstrate that a station will broadcast aircraft target messages (ground TIV) with the correct format.						
Context	Step	Action	PCO	Action Qualifier	Ref	Comment
preamble	1	do		M_POWER_UP.		Prepare the transceiver for testing.
test body	2	rep x		x:={P,Q,R,S}.		Repeat test for 4 sets of parameters.
	3	send	AppIn	REQUEST TO TRANSMIT TIS_AIRCRAFT_GRD_A (TIS_AIRCRAFT_GRD_APPIN_PARAMETERS(x)).		Send an instruction at the App In PCO to the station under test to transmit an aircraft target message (ground service) Inclusion of "fidty" and "call" information here does not imply these parameters will necessarily be broadcast.
	4	await	RF	BURST (s:= add_A) broadcast by station under test.		Wait for the target message to be broadcast by station under test.
	5	verify	RF	BURST (s:= add_A) has the format of "TIS_AC_GRD_a".	TGa	Verify that the transmitted burst is the same as "TIS_AC_GRD_a" set out in burst format section.
	6	verify	RF	TIS_AIRCRAFT_GRD_RF_OUT_PARAMETERS(x)		Verify that the content of the information output by station under test at the RF PCO is correct.
	7	end rep		next x.		
postamble	8					Bring test equipment into idle state.
Comments:						

Test Case Name:		TIS_Grd_Veh_A				
Purpose: To demonstrate that a station will broadcast a ground vehicle target messages (ground TIV) with the correct format.						
Context	Step	Action	PCO	Action Qualifier	Ref	Comment
preamble	1	do		M_POWER_UP.		Prepare the transceiver for testing.
test body	2	rep x		x:={P,Q,R,S}.		Repeat test for 4 sets of parameters.
	3	send	Appln	REQUEST TO TRANSMIT GROUND VEHICLE TARGET MESSAGE (TIS_GRD_VEH_APPIN_PARAMETERS(x)).		Send an instruction at the App In PCO to the station under test to transmit a ground vehicle target message.
	4	await	RF	BURST (s:= add_A) broadcast by station A.		Wait for the target message to be broadcast by station A.
	5	verify	RF	BURST (s:= add_A) has the format of "TIS_GRD_VEH_a".	TVa	Verify that the transmitted burst is the same as "TIS_GRD_VEH_a" set out in burst format section.
	6	verify	RF	TIS_GRD_VEH_RF_OUT_PARAMETERS(x).		Verify that the content of the information output by station under test at the RF PCO is correct.
	7	end rep		next x.		
postamble	6					Bring test equipment into idle state.
Comments:						

Test Case Name: TIS_Veh_Default_A						
Purpose: To demonstrate that if no information for a target is provided implying that it is an aircraft (Mode A code, callsign, registration marking or emitter category), then it will be regarded as a vehicle target until further information is provided.						
Context	Step	Action	PCO	Action Qualifier	Ref	Comment
preamble	1	do		M_POWER_UP.		Prepare the transceiver for testing.
test body	2	send	AppIn	REQUEST TO TRANSMIT TARGET MESSAGE (s:= add_A; tivid:= 2; rflg:= 0; adsff:= 0; tag:= 3; rlat:= 50N; rlg:= 3E; gtk:= 10; gsp:= 50).		Send an instruction at the App In PCO to the station under test to transmit a target message, without specific information that it is an aircraft.
	3	await	RF	BURST (s:= add_A) broadcast by station A.		Wait for the target message to be broadcast by station A.
	4	verify	RF	TIS_GRD_AIR_a (s = add_A; tivid = 2; rflg = 0; adsff = 0; tag = 3; rlat = 50N; rlg = 3E; gtk = 10; gsp = 50) transmitted by station under test.	TVa	Verify that the corresponding transmitted target message is the appropriate message for a ground vehicle.
postamble	5					Bring test equipment into idle state.
Comments:						

Test Case Name: FIS_METAR_A						
Purpose: To demonstrate that a station will broadcast a METAR message with the correct format.						
Context	Step	Action	PCO	Action Qualifier	Ref	Comment
preamble	1	do		M_POWER_UP.		Prepare the transceiver for testing.
test body	2	rep x		x:= {P, Q, R, S}.		Repeat test for 4 different sets of parameters.
	3	send	AppIn	REQUEST TO TRANSMIT FIS_METAR_a (FIS_METAR_APPIN_PARAMETERS(x)).	FMa	Instruct the station under test to broadcast a METAR message.
	4	await	RF	BURST broadcast by the station under test.		Wait for the sync burst to be broadcast by the station under test.
	5	verify	RF	BURST (s:= add_A) has the format of "FIS_METAR_a".	FMa	Verify that the transmitted burst has the same format as "FIS_METAR_a" set out in burst format section.
	6	verify	RF	FIS_METAR_RF_OUT_PARAMETERS(x).		Verify that the content of the information output by station under test at the RF PCO is correct.
	7	endrep		next x.		
postamble	8					Bring test equipment into idle state.
Comments:						

Test Case Name: FIS_SPECI_A						
Purpose: To demonstrate that a station will broadcast a SPECI message with the correct format.						
Context	Step	Action	PCO	Action Qualifier	Ref	Comment
preamble	1	do		M_POWER_UP.		Prepare the transceiver for testing.
test body	2	rep x		x:= {P, Q, R, S}.		Repeat test for 4 different sets of parameters.
	3	send	AppIn	REQUEST TO TRANSMIT FIS_SPECI_a (FIS_SPECI_APPIN_PARAMETERS(x)).	FSa	Instruct the station under test to broadcast a SPECI message.
	4	await	RF	BURST broadcast by the station under test.		Wait for the sync burst to be broadcast by the station under test.
	5	verify	RF	BURST (s:= add_A) has the format of "FIS_SPECI_a".	FSa	Verify that the transmitted burst has the same format as "FIS_SPECI_a" set out in burst format section.
	6	verify	RF	FIS_SPECI_RF_OUT_PARAMETERS(x).		Verify that the content of the information output by station under test at the RF PCO is correct.
	7	Endrep		next x.		
postamble	8					Bring test equipment into idle state.
Comments:						

Test Case Name: FIS_METAR_C						
Purpose: To demonstrate that a station will transmit METAR reports once during each update period.						
Context	Step	Action	PCO	Action Qualifier	Ref	Comment
preamble	1	do		M_POWER_UP.		Prepare the transceiver for testing.
test body	2	rep t		t={1, 2, 5}.		Start loop for repeat of the test with different update periods.
	3	send	Appln	REQUEST TO TRANSMIT METAR MESSAGES WITH PERIOD t MINUTES.		Instruct the station under test to transmit regular METAR reports according to the required update period.
	4	await	RF	FIS_METAR_a (s = add_A) transmitted by station under test.	FMa	Wait for the first METAR message to be transmitted by the station under test.
	5	record	RF	metar_time:= time at beginning of slot in which FIS_METAR_a was broadcast.	FMa	Record the time at which the METAR message was broadcast.
	6	rep 10		n:= 1.		Start loop to count 10 bursts.
	7	wait		time = metar_time + (n x 60 - 12)xt.		Wait for time t minutes less 20 % of a period.
	8	verify	RF	FIS_METAR_a received before time = metar_time + (n x 60 + 12)xt.	FMa	Verify that before time t minutes plus 20 % of a period, a METAR message has been received.
	9	endrep		n:= n + 1.		Repeat with n incremented.
	10	endrep		next t.		Repeat with the next update period.
postamble	11					Bring test equipment into idle state.
Comments:						

Test Case Name: FIS_ATIS_A						
Purpose: To demonstrate that a station will broadcast an ATIS message with the correct format.						
Context	Step	Action	PCO	Action Qualifier	Ref	Comment
Preamble	1	do		M_POWER_UP.		Prepare the transceiver for testing.
test body	2	rep x		x:= {P, Q, R, S}.		Repeat test for 4 different sets of parameters.
	3	send	Appln	REQUEST TO TRANSMIT FIS_ATIS_a (FIS_ATIS_APPIN_PARAMETERS(x)).	FAa	Instruct the station under test to broadcast an ATIS message.
	4	await	RF	BURST (s:=add_A) broadcast by the station under test.		Wait for the ATIS message to be broadcast by the station under test.
	5	verify	RF	BURST (s:= add_A) has the format of "FIS_ATIS_a".	FAa	Verify that the transmitted burst has the same format as "FIS_ATIS_a" set out in burst format section.
	6	verify	RF	FIS_ATIS_RF_OUT_PARAMETERS(x).		Verify that the content of the information output by station under test at the RF PCO is correct.
	7	Endrep		next x.		
Postamble	8					Bring test equipment into idle state.
Comments:						

Test Case Name: FIS_RCN_A						
Purpose: To demonstrate that a station will broadcast an RCN message with the correct format.						
Context	Step	Action	PCO	Action Qualifier	Ref	Comment
preamble	1	do		M_POWER_UP.		Prepare the transceiver for testing.
test body	2	rep x		x:={P,Q,R,S}.		Repeat test for 4 different sets of parameters.
	3	send	Appln	REQUEST TO TRANSMIT FIS_RCN_A (FIS_RCN_APPIN_PARAMETERS(x)).	FRa	Instruct the station under test to broadcast an RCN message.
	4	await	RF	BURST broadcast by the station under test.		Wait for the sync burst to be broadcast by the station under test.
	5	verify	RF	BURST (s:= add_A) has the format of "FIS_RCN_a".		Verify that the transmitted burst is the same as "FIS_RCN_a" set out in burst format section.
	6	verify	RF	FIS_RCN_RF_OUT_PARAMETERS(x).		Verify that the content of the information output by the station under test at the RF PCO is correct.
	7	endrep		next x.		Verify that the other fields are correct.
postamble	9					Bring test equipment into idle state.
Comments:						

Test Case Name: FIS_SIGMET_A						
Purpose: To demonstrate that a station will broadcast a SIGMET message with the correct format.						
Context	Step	Action	PCO	Action Qualifier	Ref	Comment
preamble	1	do		M_POWER_UP.		Prepare the transceiver for testing.
test body	2	rep x		x:={P,Q,R,S}.		Repeat test for 4 sets of parameters.
	3	send	Appln	REQUEST TO TRANSMIT FIS_SIGMET_A (FIS_SIGMET_APPIN_PARAMETERS(x)).		Instruct the station under test to broadcast a SIGMET message.
	4	await	RF	BURST broadcast by the station under test.		Wait for the SIGMET message to be broadcast by the station under test.
	5	verify	RF	BURST (s:= add_A) has the format of "FIS_SIGMET_a".	FSa	Verify that the transmitted burst is the same as "FIS_SIGMET_a" VDL4 burst set out in burst format section.
	6	verify	RF	FIS_SIGMET_RF_OUT_PARAMETERS(x).		Verify that the content of the information output by station under test at the RF PCO is correct.
	7	endrep		next x.		
postamble	8					Bring test equipment into idle state.
Comments:						

Test Case Name: FIS_TSA_CTR_A						
Purpose: To demonstrate that a station will broadcast a TSA message for control zones with the correct format.						
Context	Step	Action	PCO	Action Qualifier	Ref	Comment
preamble	1	do		M_POWER_UP.		Prepare the transceiver for testing.
test body	2	rep x		x:= {P, Q, R, S}.		Repeat test for 4 different sets of parameters.
	3	send	Appln	REQUEST TO TRANSMIT FIS_TSA_CTR_A" (TSA_CTR_APPIN_PARAMETERS(x)).	FTCa	Instruct the station under test to broadcast a TSA message.
	4	await	RF	BURST broadcast by the station under test.		Wait for the sync burst to be broadcast by the station under test.
	5	verify	RF	BURST (s:= add_A) has the format of "FIS_TSA_CTR_A".	FTCa	Verify that the transmitted burst has the same format as "FIS_TSA_CTR_A" set out in burst format section.
	6	verify	RF	FIS_TSA_CTR_RF_OUT_PARAMETERS(x).		Verify that the content of the information output by station under test at the RF PCO is correct.
	7	Endrep		next x.		
postamble	8					Bring test equipment into idle state.
Comments:						

Test Case Name: FIS_TSA_DNG_A						
Purpose: To demonstrate that a station will broadcast a TSA message for restricted, danger or prohibited zones with the correct format.						
Context	Step	Action	PCO	Action Qualifier	Ref	Comment
preamble	1	do		M_POWER_UP.		Prepare the transceiver for testing.
test body	2	rep x		x:= {P, Q, R, S}.		Repeat test for 4 different sets of parameters.
	3	send	Appln	REQUEST TO TRANSMIT FIS_TSA_DNG_A" (FIS_TSA_DNG_APPIN_PARAMETERS(x)).	FTDa	Instruct the station under test to broadcast a TSA message.
	4	await	RF	BURST broadcast by the station under test.		Wait for the sync burst to be broadcast by the station under test.
	5	verify	RF	BURST (s:= add_A) has the format of "FIS_TSA_DNG_A".	FTDa	Verify that the transmitted burst has the same format as "FIS_TSA_DNG_A" set out in burst format section.
	6	verify	RF	FIS_TSA_DNG_RF_OUT_PARAMETERS(x).		Verify that the content of the information output by station under test at the RF PCO is correct.
	7	Endrep		next x.		
postamble	8					Bring test equipment into idle state.
Comments:						

Test Case Name:		FIS_Request_C				
Purpose:		To demonstrate that a ground station which receives a broadcast report request message from a mobile that does not reserve slot(s) for the response, will broadcast the information at the required rate.				
Context	Step	Action	PCO	Action Qualifier	Ref	Comment
preamble	1	do		M_POWER_UP.		Prepare the transceiver for testing.
test body	2	rep 2		n:=1.		Start loop.
	3	send	RF	IF n=1 THEN FIS_REQUEST_a (s:=add_B; fmi:=5; mrq:= 1; locl:=EGLL).	FQa	Send a broadcast report request message with a null reservation from a simulated station B to the station under test.
	4	send	RF	IF n=2 THEN FIS_REQUEST_a (s:=add_B; fmi:=5; mrq:= 2; locl:=EGLC).	FQa	A different request message is sent when the test is repeated.
	5	record	RF	burst_time:= time at beginning of slot in which FIS_REQUEST_a was transmitted.	FQa	Record the time at which the FIS request message was transmitted by the simulated station B.
	6	rep 3		m:=1.		Start loop to measure transmission times.
	7	wait	RF	time = burst_time + m × 60 - 12.		Wait for m minutes less 20 % of a minute.
	8	verify	RF	FIS-B BURST (s:= add_A) transmitted by the station under test before time = burst_time + m × 60 + 12.		Verify that the requested message is received before time m minutes plus 20 % of a minute.
	9	verify		FIS-B BURST (s:= add_A) has the format of: IF n = 1 THEN FIS_ATIS_a IF n = 2 THEN FIS_RCN_a FIS-B BURST (s:= add_A) provides information for the requested airport.	FAa FRa	Verify that the transmitted burst is of the correct format as set out in the burst format section. Verify the message provides the information for the requested airport.
	10	endrep		m:= m + 1.		End loop.
	11	endrep		n:=n + 1.		End loop.
postamble	12					Bring test equipment into idle state.
Comments:						

Test Case Name:		FIS_Request_D				
Purpose:		To demonstrate that a ground station which receives an addressed report request message from a mobile that reserves a specific slot for the response, will broadcast the requested information in the reserved slot.				
Context	Step	Action	PCO	Action Qualifier	Ref	Comment
preamble	1	do		M_POWER_UP.		Prepare the transceiver for testing.
test body	2	rep 2		n:=1.		Start loop.
	3	send	RF	IF n=1 THEN FIS_REQUEST_b (s:=add_B; d:=add_A; fmi:=5; mrq:= 1; locl:=EGLL; sdf:=0; ro:=500; lg:=2; pr:=12)	FQb	Send a report request message with a unicast reservation from a simulated station B to the station under test.
	4	send	RF	IF n=2 THEN FIS_REQUEST_b (s:=add_B; d:=add_A; fmi:=5; mrq:= 2; locl:=EGLC; sdf:=0; ro:=500; lg:=2; pr:=12).	FQb	A different request message is sent when the test is repeated.
	5	record	RF	burst_time:= time at beginning of slot in which FIS_REQUEST_b was transmitted.	FQb	Record the time at which the FIS request message was transmitted by the simulated station B.
	6	wait		time = burst_time + 500 x (60/M1)		Wait for the reserved slot.
	7	verify	RF	FIS-B BURST (s:= add_A) transmitted by the station under test in slot beginning at time = burst_time + 500 x (60/M1).		Verify that the requested message is received in the reserved slot.
	8	verify	RF	FIS-B BURST (s:= add_A) has the format of: IF n = 1 THEN FIS_ATIS_a IF n = 2 THEN FIS_RCN_a FIS-B BURST (s:= add_A) provides information for the requested airport.	FAa FRa	Verify that the transmitted burst is the correct as set out in the burst format section. Verify the message provides the information for the requested airport.
	9	endrep		n:=n + 1.		End loop.
postamble	10					Bring test equipment into idle state.
Comments:						

Test Case Name:		FIS_Request_E				
Purpose:		To demonstrate that a ground station which receives an addressed report request message from a mobile that does not reserve slot(s) for the response, will broadcast the information at the required rate.				
Context	Step	Action	PCO	Action Qualifier	Ref	Comment
preamble	1	do		M_POWER_UP.		Prepare the transceiver for testing.
test body	2	rep 2		n:=1.		Start loop.
	3	send	RF	IF n=1 THEN FIS_REQUEST_c (s:=add_B; d:=add_A; fmi:=5; mrq:= 1; locl:=EGLL).	FQc	Send a report request message with a null reservation from a simulated station B to the station under test.
	4	send	RF	IF n=2 THEN FIS_REQUEST_c (s:=add_B; d:=add_A; fmi:=5; mrq:= 2; locl:=EGLC).	FQc	A different request message is sent when the test is repeated.
	5	record	RF	burst_time:= time at beginning of slot in which FIS_REQUEST_c was transmitted.	FQc	Record the time at which the FIS request message was transmitted by simulated station B.
	6	rep 3		m:=1.		Start loop to measure transmission times.
	7	wait	RF	time = burst_time + m × 60 - 12.		Wait for m minutes less 20 % of a minute.
	8	verify	RF	FIS-B BURST (s:= add_A) transmitted by the station under test before time = burst_time + m × 60 + 12.		Verify that the requested message is received before time m minutes plus 20 % of a minute.
	9	verify		FIS-B BURST (s:= add_A) has the format of: IF n = 1 THEN FIS_ATIS_a IF n = 2 THEN FIS_RCN_a FIS-B BURST (s:= add_A) provides information for the requested airport.	FAa FRa	Verify that the transmitted burst is of the correct format as set out in the burst format section. Verify the message provides the information for the requested airport.
	10	endrep		m:= m + 1.		End loop.
	11	endrep		n:=n + 1.		End loop.
postamble	12					Bring test equipment into idle state.
Comments:						

Test Case Name:		FIS_Request_F				
Purpose:		To demonstrate that a ground station which receives a broadcast report request message from a mobile that reserves a specific slot for the response, will broadcast the requested information in the reserved slot.				
Context	Step	Action	PCO	Action Qualifier	Ref	Comment
preamble	1	do		M_POWER_UP.		Prepare the transceiver for testing.
test body	2	rep 2		n:=1.		Start loop.
	3	send	RF	IF n=1 THEN FIS_REQUEST_b (s:=add_B; d:= 7; fmi:=5; mrq:= 1; locl:=EGLL; sdf:=0; ro:=500; lg:=2; pr:=12).	FQb	Send a broadcast report request message with a unicast reservation from a simulated station B to the station under test.
	4	send	RF	IF n=2 THEN FIS_REQUEST_b (s:=add_B; d:=7; fmi:=5; mrq:= 2; locl:=EGLC; sdf:=0; ro:=500; lg:=2; pr:=12).	FQb	A different request message is sent when the test is repeated.
	5	record	RF	burst_time:= time at beginning of slot in which FIS_REQUEST_b burst was transmitted.	FQb	Record the time at which the FIS request message was transmitted by the simulated station B.
	6	wait		time = burst_time + 500 x (60/M1).		Wait for the reserved slot.
	7	verify	RF	FIS-B BURST (s:= add_A) transmitted by the station under test in slot beginning at time = burst_time + 500 x (60/M1).		Verify that the requested message is received in the reserved slot.
	8	verify	RF	FIS-B BURST (s:= add_A) has the format of: IF n = 1 THEN FIS_ATIS_a IF n = 2 THEN FIS_RCN_a FIS-B BURST (s:= add_A) provides information for the requested airport.	FAa FRa	Verify that the transmitted burst is the correct as set out in the burst format section. Verify the message provides the information for the requested airport.
	9	endrep		n:=n + 1.		End loop.
postamble	10					Bring test equipment into idle state.
Comments:						

Test Case Name:		FIS_Queue_A				
Purpose:		To demonstrate that a station will correctly manage a queue of targets to be transmitted.				
Context	Step	Action	PCO	Action Qualifier	Ref	Comment
preamble	1	do		M_POWER_UP.		Prepare the transceiver for testing.
test body	2	send	Appln	REQUEST TO TRANSMIT METAR MESSAGES: FIS_METAR_a(1) (s:= add_A; fmi:= 0; vers:= 0; med:= 0; locl:=EGLL; date:=28; ti:=605; wdi:=4; wsp:=30; mxw:=1; cav:=1; trd:=1; pwf:=0; rwf:=0; qfef:=0; tem(bit 8):=0; tem(bits 1-7):=51; dew(bit 8):=0; dew(bits 1-7):=3; qnh=0; wsf:=0; ssf:=0; vdit:= 6; vdif:= 4; wgi:=7; mis:=15; misd:=4; mas:=41; masd:=7; pw:=42; cno:=2; ch:=10; cc:=3; cty:=2; qfe:=3; rw:=50; ws:=0; sst:=47; ss:=5; txt:= "METAR EGLL 0920Z 26005KT CAVOK 15/14 Q1013 NOSIG") FIS_METAR_a(2) (ws:=1; other parameters as above) FIS_METAR_a(3) (qnh=2; other parameters as above) FIS_METAR_a(4) (mis:=14; other parameters as above) FIS_METAR_a(5) (misd:=3; other parameters as above) FIS_METAR_a(6) (mas:=17; other parameters as above) FIS_METAR_a(7) (masd:=5; other parameters as above) FIS_METAR_a(8) (cty:=3; other parameters as above) FIS_METAR_a(9) (sst:=50; other parameters as above) FIS_METAR_a(10) (date:=10; other parameters as above).	FMa	Send (as if from a FIS-B server) to the station under test all at once, ten different METAR messages to be transmitted. Note that index immediately following FIS_METAR_a is not a transmitted parameter.
	3	rep 4		n:= 1.		Start loop.
	4	verify	RF	FIS_METAR_a(n) (s=add_A; med=0) transmitted.	FMa	Verify that the first four METAR messages have been transmitted.
	5	endrep		n:=n + 1.		End loop.
	6	send	Appln	REQUEST TO TRANSMIT METAR MESSAGES: FIS_METAR_a(6) (med:=1; mas:=15) FIS_METAR_a(8) (med:=1; cty:=2) FIS_METAR_a(9) (med:=1; sst:=40).	FMa	Send updated messages for three of the METAR messages that have not yet been transmitted by the ground station, each with a higher message edition number.
	7	rep 3		n:= {5, 7, 10}.		Start loop.

Test Case Name:		FIS_Queue_A				
Purpose: To demonstrate that a station will correctly manage a queue of targets to be transmitted.						
Context	Step	Action	PCO	Action Qualifier	Ref	Comment
	8	verify	RF	FIS_METAR_a(n) (s=add_A; med=0) transmitted IF n=5 THEN misd=3 IF n=7 THEN masd=5 IF n=10 THEN date=10.	FMa	Verify that the METAR messages for which updates where not provided are still transmitted.
	9	endrep		next n.		End loop.
	10	rep 3		n:= {6, 8, 9}.		Start loop.
	11	verify	RF	FIS_METAR_a(n) (s=add_A; med:=1) transmitted IF n=6 THEN mas=15 IF n=8 THEN cty=2 IF n=9 THEN sst=40.	FMa	Verify that for the three messages that were updated, the updated messages are sent in place of the original messages.
	12	endrep		next n.		End loop.
postamble	13					Bring test equipment into idle state.
Comments:						

Test Case Name:		FIS_Slot_A				
Purpose: To demonstrate that a station will transmit FIS-B messages in slots as instructed by the FIS-B server.						
Context	Step	Action	PCO	Action Qualifier	Ref	Comment
preamble	1	do		M_POWER_UP.		Prepare the transceiver for testing.
test body	2	send	Appln	REQUEST TO TRANSMIT ATIS MESSAGE (s:= add_A; fmi:= 1; vers:= 0; med:= 0; locl:=EGLL; date:=28; ti:=605; hd:=3; tran:=3; oth:=0; aavl(bits 1-11):=615; aavl(bit 12):=1; wdi:=4; wsp:=30; tem(bit8):=0; tem(bits1-7):=5; dew(bit8):=0; dew(bits 1-7):=5; qnh:=3; ruf:=0; ftxt:=1; mxw:=1; cav:=0; trd:=1; qfef:=0; wsf:=1; pwf:=1; rwf:=0; vdit:= 6; vdif:= 4; wgi:=7; mis:=15; misd:=4; mas:=41; masd:=7; cno:=2; cc:=3; ch:=10 cty:=2; pw:=18; rw:=50; qfe:=248; run(bits 1-6):=25; run(bits7-8):=2; aptf:=0; apty:= 3; rdp:=1; rcon:=1; dod:=0; brk:=1; rrl:=127; rrw:=68; rvt:=15; rvm:=18; rve:=24; ravl(bits 1-11):=605; ravl(bit 12):= 1; rus:=3; ws:=0; txt:= "ATIS RWY: 25R /18 TL: 70 SR:0538 SS:1647 ETOU RWY: 26") TRANSMIT IN FIRST AVAILABLE SLOT TRANSMIT 3 TIMES PER MINUTE FOR THREE MINUTES.		Instruct (as if a FIS-B server) the station under test to transmit an ATIS message in the first slot available, and thereafter three times per minute for three minutes.
	3	await		Next available slot.		Wait for the next available slot.
	4	verify	RF	FIS_ATIS_a (s:=add_A) transmitted in the available slot.	FAa	Verify that ATIS message was transmitted by the station under test in the first free slot available.
	5	record	RF	atis_time:= time at beginning of slot in which FIS_ATIS_a (s:=add_A) transmitted.	FAa	Record the time that the ATIS message was transmitted.
	6	rep 9		n:= 1.		Start loop.
	7	wait		time:= atis_time + (20 - 4) x n		Wait for the expected time at which the ATIS message is next transmitted less 20 %.
	8	verify	RF	FIS_ATIS_a (s:=add_A) transmitted before time:= atis_time + (20 + 4) x n.	FAa	Verify that the ATIS message is transmitted before the expected time plus 20 %.
	9	endrep		n:= n + 1.		End loop.

Test Case Name:		FIS_Slot_A				
Purpose: To demonstrate that a station will transmit FIS-B messages in slots as instructed by the FIS-B server.						
Context	Step	Action	PCO	Action Qualifier	Ref	Comment
	10	send	Appln	REQUEST TO TRANSMIT ATIS MESSAGE (s:= add_G; fmi:= 1; vers:= 0; med:= 0; locl:=EGLL; date:=28; ti:=605; hd:=3; tran:=3; oth:=0; aavl(bits 1-11):=615; aavl(bit 12):=1; wdi:=4; wsp:=30; tem(bit8):=0; tem(bits1-7):=5; dew(bit8):=0; dew(bits 1-7):=5; qnh:=3; ruf:=0; fxt:=1; mxw:=1; cav:=0; trd:=1; qfef:=0; wsf:=1; pwf:=1; rwf:=0; vdit:= 6; vdif:= 4; wgi:=7; mis:=15; misd:=4; mas:=41; masd:=7; cno:=2; cc:=3; ch:=10 cty:=2; pw:=18; rw:=50; qfe:=248; run(bits 1-6):=25; run(bits7-8):=2; aptf:=0; apty:= 3; rdp:=1; rcon:=1; dod:=0; brk:=1; rrl:=127; rrw:=68; rvt:=15; rvm:=18; rve:=24; ravl(bits 1-11):=605; ravl(bit 12):= 1; rus:=3; ws:=0; txt:= "ATIS RWY: 25R /18 TL: 70 SR:0538 SS:1647 ETOU RWY: 26") TRANSMIT IN SECOND SLOT OF THE UTC SECOND TRANSMIT 3 TIMES PER MINUTE FOR THREE MINUTES.		Instruct the station under test to transmit in the second slot of the UTC second, and then three times per minute for three minutes.
	11	await		Next slot that is the second slot in a UTC second.		Wait for the next slot that is the second slot in a UTC second.
	12	verify	RF	FIS_ATIS_a (s:=add_A) transmitted in second slot of UTC second.		Verify that ATIS message was transmitted by the station under test in the second slot of the UTC second.
	13	record	RF	atis_time:= time at beginning of slot in which FIS_ATIS_a (s:=add_A) transmitted.	FAa	Record the time that the ATIS message was transmitted.
	14	rep 9		n:= 1.		Start loop.
	15	wait		time:= atis_time + (20 - 4) x n.		Wait for the expected time at which the ATIS message is next transmitted less 20 %.
	16	verify	RF	FIS_ATIS_a (s:=add_A) transmitted before time:= atis_time + (20 + 4) x n.	FAa	Verify the ATIS message is transmitted before the expected time plus 20 %.
	17	endrep		n:= n + 1.		End loop.

Test Case Name:		FIS_Slot_A				
Purpose: To demonstrate that a station will transmit FIS-B messages in slots as instructed by the FIS-B server.						
Context	Step	Action	PCO	Action Qualifier	Ref	Comment
	18	send	App_In	REQUEST TO TRANSMIT ATIS MESSAGE (s:= add_G; fmi:= 1; vers:= 0; med:= 0; locl:=EGLL; date:=28; ti:=605; hd:=3; tran:=3; oth:=0; aavl(bits 1-11):=615; aavl(bit 12):=1; wdi:=4; wsp:=30; tem(bit8):=0; tem(bits1-7):=5; dew(bit8):=0; dew(bits 1-7):=5; qnh:=3; ruf:=0; ftxt:=1; mxw:=1; cav:=0; trd:=1; qfef:=0; wsf:=1; pwf:=1; rwf:=0; vdit:= 6; vdif:= 4; wgi:=7; mis:=15; misd:=4; mas:=41; masd:=7; cno:=2; cc:=3; ch:=10 cty:=2; pw:=18; rw:=50; qfe:=248; run(bits 1-6):=25; run(bits7-8):=2; aptf:=0; apty:= 3; rdp:=1; rcon:=1; dod:=0; brk:=1; rrl:=127; rrw:=68; rvt:=15; rvm:=18; rve:=24; ravl(bits 1-11):=605; ravl(bit 12):= 1; rus:=3; ws:=0; txt:= "ATIS RWY: 25R /18 TL: 70 SR:0538 SS:1647 ETOU RWY: 26") TRANSMIT IN TENTH SLOT AFTER CURRENT SLOT TRANSMIT 3 TIMES PER MINUTE FOR THREE MINUTES.		Instruct the station under test to transmit in the tenth slot after the current slot, and then three times per minute for three minutes.
	19	record	Appln	instruct_time:= time at beginning of slot after instruction from FIS-B server was transmitted.	FAa	Record the time that the ATIS message was transmitted.
	20	verify	RF	FIS_ATIS_a (s:=add_A) transmitted in slot beginning at time:= instruct_time + 10 x (60/M1).		Verify that the ATIS message was transmitted by the station under test in the tenth slot after the current slot.
	21	record	RF	atis_time:= time at beginning of slot in which FIS_ATIS_a (s:=add_A) transmitted.	FAa	Record the time that the ATIS message was transmitted.
	22	rep 9		n:= 1.		Start loop.
	23	wait		time:= atis_time + (20 - 4) x n.		Wait for the expected time at which the ATIS message is next transmitted less 20 %.
	24	verify	RF	FIS_ATIS_a (s:=add_A) transmitted before time:= atis_time + (20 + 4) x n.	FAa	Verify that the ATIS message is transmitted before the expected time plus 20 %.
	25	endrep		n:= n + 1.		End loop.
postamble	26					Bring test equipment into idle state.
Comments:						

Test Case Name: FIS_AddInfo_A						
Purpose: To demonstrate that a station passes requests for additional information to the FIS-B server.						
Context	Step	Action	PCO	Action Qualifier	Ref	Comment
preamble	1	do		M_POWER_UP.		Prepare the transceiver for testing.
test body	2	send	RF	FIS_REQUEST_a (s:=add_B; fmi:=5; mrq:= 1; loci:=EGLL).	FQa	Send a report request message with a null reservation from a simulated station B to the station under test.
	3	verify	AppOut	MESSAGE TO FIS-B SERVER: REQUEST FOR UPDATED ATIS MESSAGE INFORMATION.		Wait for a message to be sent by the station under test to the FIS-B server requesting additional ATIS information.
	4	send	RF	FIS_REQUEST_a (s:=add_C; fmi:=5; mrq:= 2; loci:=EGLC).	FQa	Send a report request message with a null reservation from a simulated station C to the station under test.
	5	verify	AppOut	MESSAGE TO FIS-B SERVER: REQUEST FOR UPDATED RCN MESSAGE INFORMATION.		Wait for a message to be sent by the station under test to the FIS-B server requesting additional RCN information.
postamble	6					Bring test equipment into idle state.
Comments:						

Test Case Name: FIS_Request_Rec_A						
Purpose: To demonstrate that a station will correctly process a received FIS-B report request message with a null reservation.						
Context	Step	Action	PCO	Action Qualifier	Ref	Comment
preamble	1	do		M_POWER_UP.		Prepare the transceiver for testing.
test body	2	rep x		x:={P, Q, R, S}.		Repeat test for 4 different sets of parameters.
	3	send	RF	FIS_REQUEST_a (s:= add_B) (FIS_REQUEST_RF_IN_PARAMETERS(x)).	FQa	Send a report request message with null reservation to the station under test from a simulated station B.
	4	await	AppOut	REQUEST MESSAGE INFORMATION.		Wait for the message information to be output by station under test at the AppOut PCO.
	5	verify	AppOut	FIS_REQUEST_APPOUT_PARAMETERS(x).		Verify that the content of the information output by station under test at the AppOut PCO is correct.
	6	endrep		next x.		
postamble	7					Bring test equipment into idle state.
Comments:						

Test Case Name: FIS_Request_Rec_B						
Purpose: To demonstrate that a station will correctly process a received FIS-B report request message with a unicast reservation.						
Context	Step	Action	PCO	Action Qualifier	Ref	Comment
preamble	1	do		M_POWER_UP.		Prepare the transceiver for testing.
test body	2	rep x		x:={P, Q, R, S}.		Repeat test for 4 different sets of parameters.
	3	send	RF	FIS_REQUEST_b (s:= add_B) (FIS_REQUEST_RF_IN_PARAMETERS(x)).	FQb	Send a report request message with a unicast reservation to the station under test from a simulated station B.
	4	await	AppOut	REQUEST MESSAGE INFORMATION.		Wait for the message information to be output by station under test at the AppOut PCO.
	5	verify	AppOut	FIS_REQUEST_APPOUT_PARAMETERS(x).		Verify that the content of the information output by station under test at the AppOut PCO is correct.
	6	endrep		next x.		
postamble	7					Bring test equipment into idle state.
Comments:						

Test Case Name: GNS_Type1_Message_A						
Purpose: To demonstrate that a station will broadcast a GNS-B Type 1 message with the correct format.						
Context	Step	Action	PCO	Action Qualifier	Ref	Comment
preamble	1	do		M_POWER_UP.		Prepare the transceiver for testing.
test body	2	rep x		x:= {P, Q, R, S}.		Repeat test for 4 different sets of parameters.
	3	send	AppIn	REQUEST TO TRANSMIT GNS_TYPE1_a (GNS_TYPE1_APPIN_PARAMETERS(x)).	G1a	Instruct the station under test to broadcast a GNS Type 1 message.
	4	await	RF	BURST (s:=add_A) broadcast by the station under test.		Wait for the GNS message to be broadcast by the station under test.
	5	verify	RF	BURST (s:= add_A) has the format of "GNS_TYPE1_a".	G1a	Verify that the transmitted burst has the same format as "GNS_TYPE1_a" set out in burst format section.
	6	verify	RF	GNS_TYPE1_RF_OUT_PARAMETERS(x).		Verify that the content of the information output by station under test at the RF PCO is correct.
	7	Endrep		next x.		End loop.
postamble	8					Bring test equipment into idle state.
Comments:						

Test Case Name: GNS_Type2_Message_A						
Purpose: To demonstrate that a station will broadcast a GNS-B Type 2 message with the correct format.						
Context	Step	Action	PCO	Action Qualifier	Ref	Comment
preamble	1	do		M_POWER_UP.		Prepare the transceiver for testing.
test body	2	rep x		x:= {P, Q, R, S}.		Repeat test for 4 different sets of parameters.
	3	send	Appln	REQUEST TO TRANSMIT GNS_TYPE2_a (GNS_TYPE2_APPIN_PARAMETERS(x)).	G2a	Instruct the station under test to broadcast a GNS Type 2 message.
	4	await	RF	BURST (s:=add_A) broadcast by the station under test.		Wait for the GNS message to be broadcast by the station under test.
	5	verify	RF	BURST (s:= add_A) has the format of "GNS_TYPE2_a".	G2a	Verify that the transmitted burst has the same format as "GNS_TYPE2_a" set out in burst format section.
	6	verify	RF	GNS_TYPE2_RF_OUT_PARAMETERS(x).		Verify that the content of the information output by station under test at the RF PCO is correct.
	7	Endrep		next x.		End loop.
postamble	8					Bring test equipment into idle state.
Comments:						

Test Case Name: GNS_Type4_Message_A						
Purpose: To demonstrate that a station will broadcast a GNS-B Type 4 message with the correct format.						
Context	Step	Action	PCO	Action Qualifier	Ref	Comment
preamble	1	do		M_POWER_UP.		Prepare the transceiver for testing.
test body	2	rep x		x:= {P, Q, R, S}.		Repeat test for 4 different sets of parameters.
	3	send	Appln	REQUEST TO TRANSMIT GNS_TYPE4_a (GNS_TYPE4_APPIN_PARAMETERS(x)).	G4a	Instruct the station under test to broadcast a GNS Type 4 message.
	4	await	RF	BURST (s:=add_A) broadcast by the station under test.		Wait for the GNS message to be broadcast by the station under test.
	5	verify	RF	BURST (s:= add_A) has the format of "GNS_TYPE4_a".	G4a	Verify that the transmitted burst has the same format as "GNS_TYPE4_a" set out in burst format section.
	6	verify	RF	GNS_TYPE4_RF_OUT_PARAMETERS(x).		Verify that the content of the information output by station under test at the RF PCO is correct.
	7	Endrep		next x.		End loop.
postamble	8					Bring test equipment into idle state.
Comments:						

Annex A (informative): Cross reference matrix

Table A.1 outlines the mapping between the VDL Mode 4 Ground station ADS-B requirements and the related test procedures. The table also provides a cross reference to the ICAO reference material from which many of the requirements within the present document are derived. In these tables:

- column 1 is a reference to the requirements in the present document;
- column 2 is a reference to the equivalent requirements in [1];
- column 3 identifies individual requirements within [1];
- column 4 identifies clause titles taken from the present document;
- column 5 is a reference to testing requirements specified elsewhere in the present document. Several tests verify a whole group of requirements. They are only mentioned in the first row of such a group, usually a headline. The applicability of these tests to the subordinated requirements is indicated by ditto marks (") in the rows following the first instance of a test case name. Amplification of individual entries is provided by the following notes.
- column 6 qualifies each test procedure to be:
 - Essential: meaning that it is included with the Essential Radio Test Suite and therefore the requirement shall be demonstrated to be met in accordance with the referenced procedures.
 - Other: meaning that the test procedure is illustrative but other means of demonstrating compliance with the requirement are permitted.
 - eXcluded: meaning that there is no specific test for the requirement.

NOTE 1: The clause number in column 1 is a headline or an introduction to requirements that are detailed in subsequent clauses. No test can be applied.

NOTE 1a: The clause number in column 1 is a definition. No test can be applied.

NOTE 2: The requirements listed in column 1 does not allow definition of a satisfactory go/no go test, for example, because it would be technically infeasible, or economically unreasonable. There are circumstances where the implementer can provide reasoned argument or test evidence that the implementation under test does conform to the requirements in column 1. For each of these circumstances the implementer may be required to satisfy the authorities by separate technical evidence.

NOTE 3: The requirements listed in column 1 is applicable only to VDL Mode 4 airborne equipment. No ground equipment test is required.

NOTE 4: This topic is heavily dependent on the implementation or results from a recommendation. No particular test is therefore provided in the present document.

NOTE 5: All tests whether "E" or "O" are relevant to the requirements. Rows designated "E" collectively make up the Essential Radio Test Suite; those designated "O" make up the Other Test Suite; for those designated "X" there is no test specified corresponding to the requirement . All tests classified "E" shall be performed as specified with satisfactory outcomes as a necessary condition for a presumption of conformity. Requirements associated with tests classified "O" or "X" must be complied with as a necessary condition for presumption of conformity, although conformance with the requirement may be claimed by an equivalent test or by manufacturer's assertion supported by appropriate entries in the technical construction file.

Table A.1: VDL Mode 4 requirements for ADS-B

Requirement reference	Reference in [1]	Req	Title	Test Case	E/O/X
5.1.1	3.3		Information Field Formats	See note 1	X
5.1.1.1	3.3.1	a		See note 1a	X
5.1.1.2	3.3.2	a		ADSB_Basic_Rec_A ADSB_High_Dynamic_Rec_A ADSB_Full_Position_Rec_A ADSB_Basic_Ground_A ADSB_UTC_Time_A ADSB_Two_Slot_TCP/SVQ_Rec_A ADSB_Single_Slot_TCP_Rec_A ADSB_Single_Slot_SVQ_Rec_A ADSB_Aircraft_Data_Rec_A ADSB_High_Resolution_Rec_A	E
5.1.1.3	3.3.3	a		See note 1a	X
5.1.1.4	3.3.3.1	a		See note 1a	X
5.1.1.5	3.3.3.2	a		See note 1a	X
5.1.1.6	3.3.3.2	b		See note 1a	X
5.1.1.7	3.3.4	a		See note 1a	X
5.1.1.8	3.3.5	a		See note 1a	X
5.1.1.9	3.3.6	a		See note 1a	X
5.1.1.10	3.3.7	a		See note 1a	X
5.1.1.11	3.3.8	a		See note 1a	X
5.1.1.12	3.3.9	a		See note 1a	X
5.1.1.13				See note 1a	X
5.1.1.14				See note 1a	X
5.1.2	3.4		ADS-B Request	See note 1	X
5.1.2.1	3.4.1		ADS-B Request Format	See note 1	X
5.1.2.1.1	3.4.1	a		ADSB_Request_A	E
5.1.2.1.2	3.4.1	b		ADSB_Request_A ADSB_Request_B ADSB_Request_C ADSB_Request_D	E
5.1.2.1.3	3.4.1	c		See note 1a	X
5.1.2.1.4	3.4.1	d		See note 1a	X
5.1.2.1.5	3.4.1	e		See note 1a	X
5.1.2.2	3.4.2		Sleep Mode	See note 1	X
5.1.2.2.1	3.4.2	a		ADSB_Request_C ADSB_Request_D	E
5.1.2.2.2	3.4.2	b		ADSB_Request_A ADSB_Request_B	E
5.1.2.3	3.4.3		Automatic Selection of Variable Information Fields	See note 1	X
5.1.2.3.1	3.4.3	a		ADSB_Request_A ADSB_Request_C	E
5.1.2.3.2	3.4.3	b		ADSB_Request_A ADSB_Request_C	E
5.1.3	3.5		Default ADS-B Reporting	See note 1	X
5.1.3.1	3.5a	a		ADSB_reporting	E
5.1.3.2	3.5.1	a		See note 4	O
5.1.4	3.6		ADS-B Procedures	See note 1	X
5.1.4.1	3.6.1.1	a		ADSB_Request_B ADSB_Request_D	E
5.1.4.2	3.6.1.1	b		ADSB_Request_A ADSB_Request_C	E
5.1.4.3	3.6.1.1	c		ADSB_Request_A ADSB_Request_B	E
5.1.4.4	3.6.1.2	a		ADSB_Request_C ADSB_Request_D	E
5.1.4.5	3.6.2	a		ADSB_request_time	E
5.1.4.6	3.6.3	a		ADSB_priority	E
5.1.4.7	3.6.4	f		ADSB_TCP_flag_C	E
5.1.5	3.7		CTRL Parameters	See note 1	X
5.1.5.1	3.7.1		Directory of Service (DOS) Message	See note 1	X

Requirement reference	Reference in [1]	Req	Title	Test Case	E/O/X
5.1.5.1.1	3.7.1.1	a		ADSB_DOS_A	E
5.1.5.1.2	3.7.1.1	b		See note 1a	X
5.1.5.1.3	3.7.1.2	a		See note 1a	X
5.1.5.2	3.7.2		Channel Management Parameter	See note 1	X
5.1.5.2.1	1.5.3.6.7.1	a		See note 1a	X
5.1.5.2.2	1.5.3.6.7.2	a		See note 1a	X
5.1.5.2.3	3.7.2	a		ADSB_Channel_A	E
5.1.5.2.4	3.7.2	b		ADSB_Channel_A	E
5.1.5.2.5	3.7.2.1.1	a		ADSB_Channel_A	E
5.1.5.2.6	3.7.2.1.2	b		See note 1a	X
5.1.5.2.7	3.7.2.1.2	b		See note 1a	X
5.1.5.2.8	3.7.2.2	a		ADSB_Channel_A	E
5.1.5.2.9	3.7.2.2.1	a		See note 1a	X
5.1.5.2.10	3.7.2.2.2	a		ADSB_Channel_A	E
5.1.5.2.11	3.7.2.2.3.1	a		ADSB_Channel_A	E
5.1.5.2.12	3.7.2.2.3.2	a		ADSB_Channel_A	E
5.1.5.2.13	3.7.2.2.4.1	a		ADSB_Channel_A	E
5.1.5.2.14	3.7.2.2.4.1	b		ADSB_Channel_A	E
5.1.5.2.15	3.7.2.2.4.2	a		ADSB_Directed_Slot_A	E
5.1.5.2.16	3.7.2.2.5	a		ADSB_Channel_D	E
5.1.5.2.17	3.7.2.2.5	b		See note 1a	X
5.1.5.2.18	3.7.2.4.1	a		ADSB_Channel_B	E
5.1.5.2.19	3.7.2.4.2	a		ADSB_Channel_B	E
5.1.5.2.20	3.7.2.6.1	a		ADSB_Channel_D	E
5.1.5.2.21	3.7.2.6.2.1	a		ADSB_Channel_A	E
5.1.5.2.22	3.7.2.6.2.1	b		ADSB_Channel_A	E
5.1.5.2.23	3.7.2.7	a		ADSB_Channel_A	E
5.1.5.2.24	3.7.2.8	a		ADSB_Channel_A	E
5.1.5.2.25	3.7.2.9.1	a		ADSB_Channel_A	E
5.1.5.2.26	3.7.2.9.2	a		ADSB_Channel_A	E
5.1.5.2.27	3.7.2.9.2	b		ADSB_Channel_A	E
5.1.5.2.28	3.7.2.9.2	c		ADSB_Channel_C	E
5.1.6	4		Definitions for Compact Position Reporting	See note 1	X
5.1.6.1	4.6		Information Field Offset Encoding	See note 1	X
5.1.6.1.1	4.6.1	a		CPR_Encode_Offset	E
5.1.6.1.2	4.6.1	b		CPR_Encode_Offset	E
5.1.6.1.3	4.6.2	a		See note 1a	X
5.1.6.1.4	4.6.3.1	a		See note 1a	X
5.1.6.1.5	4.6.3.2	a		See note 1a	X
5.1.6.1.6	4.6.3.3	a		See note 1a	X
5.1.6.2	4.7		Information Field Offset Decoding	See note 1	X
5.1.6.2.1	4.7.1	a		CPR_Decode_Offset	E
5.1.6.2.2	4.7.2	a		See note 1a	X
5.1.6.2.3	4.7.3.1	a		See note 1a	X
5.1.6.2.4	4.7.3.2	a		See note 1a	X
5.1.6.3	4.8		Patch ID Encoding	See note 1	X
5.1.6.3.1	4.8.1	a		CPR_Encode_Offset	E
5.1.6.3.2	4.8.2	a		See note 1a	X
5.1.6.3.3	4.8.3	a		See note 1a	X
5.1.6.4	4.9		Patch ID Decoding	See note 1	X
5.1.6.4.1	4.9.1	a		CPR_Decode_Offset	E
5.1.6.4.2	4.9.2	a		See note 1a	X
5.1.6.4.3	4.9.3.1	a		See note 1a	X
5.1.6.4.4	4.9.3.2	a		See note 1a	X

Table A.2 outlines the mapping between the VDL Mode 4 Ground station TIS-B requirements and the related test procedures. In these tables:

- column 1 is a reference to the requirement in the present document;
- column 2 identifies clause titles taken from the present document;
- column 3 qualifies each test procedure to be:
 - Essential: meaning that it is included with the Essential Radio Test Suite and therefore the requirement shall be demonstrated to be met in accordance with the referenced procedures.
 - Other: meaning that the test procedure is illustrative but other means of demonstrating compliance with the requirement are permitted.
 - eXcluded: meaning that there is no specific test for the requirement.

NOTE 1: The clause number in column 1 is a headline or an introduction to requirements that are detailed in subsequent clauses. No test can be applied.

NOTE 1a: The clause number in column 1 is a definition. No test can be applied.

NOTE 2: The requirements listed in column 1 does not allow definition of a satisfactory go/no go test, for example, because it would be technically infeasible, or economically unreasonable. There are circumstances where the implementer can provide reasoned argument or test evidence that the implementation under test does conform to the requirements in column 1. For each of these circumstances the implementer may be required to satisfy the authorities by separate technical evidence.

NOTE 3: All tests whether "E" or "O" are relevant to the requirements. Rows designated "E" collectively make up the Essential Radio Test Suite; those designated "O" make up the Other Test Suite; for those designated "X" there is no test specified corresponding to the requirement . All tests classified "E" shall be performed as specified with satisfactory outcomes as a necessary condition for a presumption of conformity. Requirements associated with tests classified "O" or "X" must be complied with as a necessary condition for presumption of conformity, although conformance with the requirement may be claimed by an equivalent test or by manufacturer's assertion supported by appropriate entries in the technical construction file.

Table A.2: VDL Mode 4 requirements for TIS-B

Requirement reference	Title	Test Case	E/O/X
5.2	Requirements for TIS-B	See note 1	X
5.2.1	Traffic information volume	See note 1	X
5.2.1.1		See note 1a	X
5.2.1.2		See note 1a	X
5.2.1.3		See note 1a	X
5.2.1.4		See note 1a	X
5.2.1.5		See note 1a	X
5.2.1.6		See note 1a	X
5.2.1.7		See note 1a	X
5.2.1.8		See note 2	O
5.2.1.9		See note 2	O
5.2.1.10		See note 2	O
5.2.1.11		TIS_Channel_B	E
5.2.1.12		See note 2	O
5.2.1.13		TIS_Manage_A	E
5.2.2	Message transmission	See note 1	X
5.2.2.1	Management messages	See note 1	X
5.2.2.1.1		TIS_Manage_C	E
5.2.2.1.2		TIS_Manage_B	E
5.2.2.1.3		TIS_Manage_A	E
5.2.2.1.4		TIS_Manage_B	E
5.2.2.2	Target Messages	See note 1	X
5.2.2.2.1		TIS_Target_Update_A TIS_Target_Update_B TIS_Target_Update_C TIS_Target_Update_D	E
5.2.2.2.2		See note 2	O
5.2.2.2.3		See note 2	O
5.2.2.3	Airport operation	See note 1	X
5.2.2.3.1		TIS_Target_Ground	E
5.2.2.3.2		TIS_Target_Ground	E
5.2.2.3.3		TIS_Veh_Default_A	E
5.2.3	Message format	See note 1	X
5.2.3.1		TIS_Manage_A TIS_Aircraft_Air_A TIS_Aircraft_Grd_A TIS_Grd_Veh_A	E
5.2.3.2		TIS_Manage_A TIS_Aircraft_Air_A TIS_Aircraft_Grd_A TIS_Grd_Veh_A	E
5.2.3.3		TIS_Manage_A TIS_Aircraft_Air_A TIS_Aircraft_Grd_A TIS_Grd_Veh_A	E
5.2.3.4		See note 2	O
5.2.3.5		See note 2	O
5.2.3.6		TIS_Manage_A TIS_Aircraft_Air_A TIS_Aircraft_Grd_A TIS_Grd_Veh_A	E
5.2.3.7		TIS_Manage_A TIS_Aircraft_Air_A TIS_Aircraft_Grd_A TIS_Grd_Veh_A	E
5.2.3.8		TIS_Manage_A TIS_Aircraft_Air_A TIS_Aircraft_Grd_A TIS_Grd_Veh_A	E
5.2.4	Management message	See note 1	X
5.2.4.1		TIS_Manage_A	E
5.2.4.2		TIS_Manage_A	E

Requirement reference	Title	Test Case	E/O/X
5.2.4.3		TIS_Manage_A	E
5.2.4.4		TIS_Manage_A	E
5.2.4.5		TIS_Manage_A	E
5.2.5	Aircraft target messages (airborne TIV)	See note 1	X
5.2.5.1		TIS_Aircraft_Air_A	E
5.2.5.2		TIS_Aircraft_Air_A	E
5.2.5.3		TIS_Aircraft_Air_A	E
5.2.5.4		TIS_Aircraft_Air_A	E
5.2.5.5		TIS_Flight_ID_A	E
5.2.5.6		TIS_Flight_ID_B	E
5.2.5.7		TIS_Aircraft_Air_A	E
5.2.6	Aircraft target messages (ground TIV)	See note 1	X
5.2.6.1		TIS_Aircraft_Grd_A	E
5.2.6.2		TIS_Aircraft_Grd_A	E
5.2.6.3		TIS_Aircraft_Grd_A	E
5.2.6.4		TIS_Aircraft_Grd_A	E
5.2.6.5		TIS_Flight_ID_A	E
5.2.6.6		TIS_Flight_ID_B	E
5.2.6.7		TIS_Aircraft_Grd_A	E
5.2.7	Ground vehicle target messages (ground TIV)	See note 1	X
5.2.7.1		TIS_Grd_Veh_A	E
5.2.7.2		TIS_Grd_Veh_A	E
5.2.8	Offset coding	See note 1	X
5.2.8.1		See note 1a	X
5.2.8.1		See note 1a	X
5.2.8.1		See note 1a	X

Table A.3 outlines the mapping between the VDL Mode 4 Ground station FIS-B requirements and the related test procedures. In these tables:

- column 1 is a reference to the requirement in the present document;
- column 2 identifies clause titles taken from the present document;
- column 3 qualifies each test procedure to be:
 - Essential: meaning that it is included with the Essential Radio Test Suite and therefore the requirement shall be demonstrated to be met in accordance with the referenced procedures.
 - Other: meaning that the test procedure is illustrative but other means of demonstrating compliance with the requirement are permitted.
 - eXcluded: meaning that there is no specific test for the requirement.

NOTE 1: The clause number in column 1 is a headline or an introduction to requirements that are detailed in subsequent clauses. No test can be applied.

NOTE 1a: The clause number in column 1 is a definition. No test can be applied.

NOTE 2: The requirements listed in column 1 does not allow definition of a satisfactory go/no go test, for example, because it would be technically infeasible, or economically unreasonable. There are circumstances where the implementer can provide reasoned argument or test evidence that the implementation under test does conform to the requirements in column 1. For each of these circumstances the implementer may be required to satisfy the authorities by separate technical evidence.

NOTE 3: All tests whether "E" or "O" are relevant to the requirements. Rows designated "E" collectively make up the Essential Radio Test Suite; those designated "O" make up the Other Test Suite; for those designated "X" there is no test specified corresponding to the requirement . All tests classified "E" shall be performed as specified with satisfactory outcomes as a necessary condition for a presumption of conformity. Requirements associated with tests classified "O" or "X" must be complied with as a necessary condition for presumption of conformity, although conformance with the requirement may be claimed by an equivalent test or by manufacturer's assertion supported by appropriate entries in the technical construction file.

Table A.3: VDL Mode 4 requirements for FIS-B

Requirement reference	Title	Test Case	E/O/X
5.3	Requirements for FIS-B	See note 1	X
5.3.1	Message format	See note 1	X
5.3.1.1		FIS_METAR_A FIS_ATIS_A FIS_RCN_A FIS_SIGMET_A FIS_SPECI_A FIS_TSA_CTR_A FIS_TSA_DNG_A	E
5.3.1.2		FIS_METAR_A FIS_ATIS_A FIS_RCN_A FIS_SIGMET_A FIS_SPECI_A FIS_TSA_CTR_A FIS_TSA_DNG_A	E
5.3.1.3		FIS_METAR_A FIS_ATIS_A FIS_RCN_A FIS_SIGMET_A FIS_SPECI_A FIS_TSA_CTR_A FIS_TSA_DNG_A	E
5.3.1.4		FIS_METAR_A FIS_ATIS_A FIS_RCN_A FIS_SIGMET_A FIS_SPECI_A FIS_TSA_CTR_A FIS_TSA_DNG_A	E
5.3.1.5		FIS_METAR_A FIS_ATIS_A FIS_RCN_A FIS_SIGMET_A FIS_SPECI_A FIS_TSA_CTR_A FIS_TSA_DNG_A	E
5.3.1.6		FIS_METAR_A FIS_ATIS_A FIS_RCN_A FIS_SIGMET_A FIS_SPECI_A FIS_TSA_CTR_A FIS_TSA_DNG_A	E
5.3.2	Meteorological Aerodrome Report (METAR) message	See note 1	X
5.3.2.1		FIS_METAR_A	E
5.3.2.2		FIS_METAR_C	E
5.3.2.3		FIS_METAR_A	E
5.3.2.4		FIS_METAR_A	E
5.3.2.5		FIS_METAR_A	E
5.3.2.6		FIS_METAR_A	E
5.3.2.7		FIS_METAR_A	E
5.3.2.8		FIS_METAR_A	E
5.3.2.9		FIS_METAR_A	E
5.3.3	Special Observations and Reports (SPECI) message	See note 1	X
5.3.3.1		FIS_SPECI_A	E
5.3.4	Automatic Terminal Information Service (ATIS) message	See note 1	X
5.3.4.1		FIS_ATIS_A	E
5.3.4.2		FIS_ATIS_A	E
5.3.4.3		FIS_ATIS_A	E

Requirement reference	Title	Test Case	E/O/X
5.3.4.4		FIS_ATIS_A	E
5.3.4.5		FIS_ATIS_A	E
5.3.4.6		FIS_ATIS_A	E
5.3.4.7		FIS_ATIS_A	E
5.3.5	Runway Condition (RCN) message	See note 1	X
5.3.5.1		FIS_RCN_A	E
5.3.5.2		FIS_RCN_A	E
5.3.6	SIGMET Reports	See note 1	X
5.3.6.1		FIS_SIGMET_A	E
5.3.6.2		FIS_SIGMET_A	E
5.3.6.3		FIS_SIGMET_A	E
5.3.6.4		FIS_SIGMET_A	E
5.3.7	Temporary Segregated Areas (TSA) message	See note 1	X
5.3.7.1		FIS_TSA_CTR_A FIS_TSA_DNG_A	E
5.3.7.2		FIS_TSA_CTR_A FIS_TSA_DNG_A	E
5.3.7.3		FIS_TSA_CTR_A	E
5.3.7.4		FIS_TSA_DNG_A	E
5.3.7.5		FIS_TSA_CTR_A FIS_TSA_DNG_A	E
5.3.8	FIS report request message	See note 1	X
5.3.8.1		FIS_Request_Rec_A	E
5.3.8.2		FIS_Request_Rec_A	E
5.3.8.3		FIS_Request_Rec_A	E
5.3.8.4		FIS_Request_Rec_A	E
5.3.8.5		FIS_Request_Rec_A	E
5.3.8.6		FIS_Request_Rec_A	E
5.3.8.7		FIS_Request_Rec_A	E
5.3.8.8		FIS_Request_C	E
5.3.8.9		FIS_Request_F	E
5.3.8.10		FIS_Request_E	E
5.3.8.11		FIS_Request_D	E
5.3.9	Ground system functions	See note 1	X
5.3.9.1		FIS_METAR_A FIS_ATIS_A FIS_RCN_A FIS_SIGMET_A FIS_SPECI_A FIS_TSA_CTR_A FIS_TSA_DNG_A	E
5.3.9.2		FIS_Slot_A	E
5.3.9.3		FIS_Slot_A	E
5.3.9.4		FIS_Slot_A	E
5.3.9.5		FIS_AddInfo_A	E
5.3.9.6		FIS_AddInfo_A	E
5.3.9.7		FIS_AddInfo_A	E
5.3.9.8		FIS_Queue_A	E
5.3.9.9		FIS_Queue_A	E
5.3.9.10		FIS_Queue_A	E

Table A.4 outlines the mapping between the VDL Mode 4 Ground station GNS-B requirements and the related test procedures. In these tables:

- column 1 is a reference to the requirement in the present document;
- column 2 identifies clause titles taken from the present document;
- column 3 qualifies each test procedure to be:
 - Essential: meaning that it is included with the Essential Radio Test Suite and therefore the requirement shall be demonstrated to be met in accordance with the referenced procedures.
 - Other: meaning that the test procedure is illustrative but other means of demonstrating compliance with the requirement are permitted.
 - eXcluded: meaning that there is no specific test for the requirement.

NOTE 1: The clause number in column 1 is a headline or an introduction to requirements that are detailed in subsequent clauses. No test can be applied.

NOTE 1a: The clause number in column 1 is a definition. No test can be applied.

NOTE 2: The requirements listed in column 1 does not allow definition of a satisfactory go/no go test, for example, because it would be technically infeasible, or economically unreasonable. There are circumstances where the implementer can provide reasoned argument or test evidence that the implementation under test does conform to the requirements in column 1. For each of these circumstances the implementer may be required to satisfy the authorities by separate technical evidence.

NOTE 3: All tests whether "E" or "O" are relevant to the requirements. Rows designated "E" collectively make up the Essential Radio Test Suite; those designated "O" make up the Other Test Suite; for those designated "X" there is no test specified corresponding to the requirement . All tests classified "E" shall be performed as specified with satisfactory outcomes as a necessary condition for a presumption of conformity. Requirements associated with tests classified "O" or "X" must be complied with as a necessary condition for presumption of conformity, although conformance with the requirement may be claimed by an equivalent test or by manufacturer's assertion supported by appropriate entries in the technical construction file.

Table A.4: VDL Mode 4 requirements for GNS-B

Requirement reference	Title	Test Case	E/O/X
5.4	Requirements for GNSS Augmentation Service Broadcast (GNS-B) message	See note 1	X
5.4.1	Message format	See note 1	X
5.4.1.1		GNS_Type1_Message_A GNS_Type2_Message_A GNS_Type4_Message_A	E
5.4.1.2		GNS_Type1_Message_A GNS_Type2_Message_A GNS_Type4_Message_A	E
5.4.1.3		GNS_Type1_Message_A GNS_Type2_Message_A GNS_Type4_Message_A	E
5.4.1.4		GNS_Type1_Message_A GNS_Type2_Message_A GNS_Type4_Message_A	E
5.4.1.5		GNS_Type1_Message_A GNS_Type2_Message_A GNS_Type4_Message_A	E
5.4.2	Message Type 1	See note 1	X
5.4.2.1		GNS_Type1_Message_A	E
5.4.2.2		GNS_Type1_Message_A	E
5.4.2.3		GNS_Type1_Message_A	E
5.4.2.4		See note 2	O
5.4.2.5		See note 1a	X
5.4.2.6		See note 2	O
5.4.3	Message Type 2	See note 1	X
5.4.3.1		GNS_Type2_Message_A	E
5.4.3.2		GNS_Type2_Message_A	E
5.4.4	Message Type 4	See note 1	X
5.4.4.1		GNS_Type4_Message_A	E
5.4.4.2		GNS_Type4_Message_A	E
5.4.4.3		GNS_Type4_Message_A	E
5.4.4.4		GNS_Type4_Message_A	E
5.4.4.5		see note 2	O
5.4.5	CRC Calculation	See note 1	X
5.4.5.1	GNS-B CRC	See note 1	X
5.4.5.1.1		See note 1a	X
5.4.5.1.2		See note 1a	X
5.4.5.1.3		See note 1a	X
5.4.5.1.4		See note 1a	X
5.4.5.1	FAS CRC	See note 1	X
5.4.5.1.1		See note 1a	X
5.4.5.1.2		See note 1a	X
5.4.5.1.3		See note 1a	X
5.4.5.1.4		See note 1a	X
5.4.5.3	Ephemeris CRC	See note 1	X
5.4.5.3.1		See note 1a	X
5.4.5.3.2		See note 1a	X
5.4.5.3.3		See note 1a	X
5.4.5.3.4		See note 1a	X
5.4.5.3.5		See note 1a	X
5.4.5.3.6		See note 1a	X
5.4.5.3.7		See note 1a	X
5.4.5.3.8		See note 1a	X

Annex B (informative): Bibliography

- EUROCAE ED-108A: "MOPS for VDL Mode 4 Aircraft Transceiver for ADS-B".
- North European ADS-B Network Update Programme: "FIS-B Service Description" V1.5.1, 10th October 2003.
- North European ADS-B Network Update Programme: "TIS-B Service Description" V1.33, 11th February 2003.
- North European ADS-B Network Update Programme: "GRAS Service Description" V1.2, 19th November 2003.
- WMO Publication No306, Manual on Codes Vol 1.1, Part A for interpretation.

List of tables

Table 5.1: ADS-B information fields	16
Table 5.2: Information field 0 hex - Basic	17
Table 5.3: Information field 1 hex - High dynamic.....	17
Table 5.4: Information field 2 hex - Full position	17
Table 5.5: Information field 3 hex - Basic ground	18
Table 5.6: Information field 4 hex - UTC time	18
Table 5.7: Information field 8 hex - Two slot TCP/SVQ.....	19
Table 5.8: Information field 9 hex - Single slot TCP	20
Table 5.9: Information field 5 hex - Single Slot SVQ.....	20
Table 5.10: Information field A1 hex - Aircraft data	21
Table 5.11: Information field AA0 hex - High resolution.....	21
Table 5.12: Information field encoding (variable data field).....	22
Table 5.13: Baro/geo offset encoding (variable data field)	24
Table 5.14: Ground speed encoding (variable data field).....	24
Table 5.15: Altitude rate magnitude encoding and decoding	25
Table 5.16: Aircraft category encoding	25
Table 5.17: Aircraft status (emergency/priority status) encoding	26
Table 5.18: Time to go subfield encoding.....	26
Table 5.19: ADS-B request bit encoding	27
Table 5.20: ADS-B request bit encoding for sleep mode parameters when sleep bit = 1	27
Table 5.21: ADS-B request bit encoding for auto parameters when auto bit = 1	28
Table 5.22: ADS-B request field encoding	28
Table 5.22a: Example of ADS-B request bit encoding for sleep mode with request for high precision variable part	29
Table 5.23: Encoding of application fields.....	30
Table 5.24: Encoding of service information field for sit = hex 00.....	30
Table 5.25: Component blocks of channel management parameter	31
Table 5.26: Header block bit encoding.....	31
Table 5.27: Header block field encoding	32
Table 5.28: Addressed destination block bit encoding.....	33
Table 5.29: Addressed destination block field encoding.....	33
Table 5.30: Regional multicast block bit encoding	34
Table 5.31: Regional multicast block field encoding	35
Table 5.32: Vertex distance encoding	35

Table 5.33: Pre-defined transmission block definition encoding	36
Table 5.34: User-defined synchronization burst transmission block bit encoding	36
Table 5.35: User-defined synchronization burst transmission block field encoding	36
Table 5.36: Non-sync burst transmission block bit encoding	36
Table 5.37: Non-sync burst transmission block field encoding	37
Table 5.38: Frequency block bit encoding	37
Table 5.39: Frequency block field encoding	37
Table 5.40: Parameter block bit encoding	38
Table 5.41: Script block bit encoding	38
Table 5.42: Script block field encoding	39
Table 5.42a: Encoding of UDATA ID (udid)	43
Table 5.43: TIS-B message identifier encoding	46
Table 5.44: Management message bit encoding	47
Table 5.45: Management message field encoding	48
Table 5.46: Aircraft target message (airborne TIV) bit encoding (with callsign as an example flight ID)	49
Table 5.47: Aircraft target message (airborne TIV) field encoding	50
Table 5.48: Aircraft target message (ground TIV) bit encoding (with callsign as an example flight ID)	51
Table 5.49: Aircraft target message (ground TIV) field encoding	52
Table 5.50: Vehicle target message (ground TIV) bit encoding	53
Table 5.51: Ground vehicle target message (ground TIV) field encoding	53
Table 5.52: Values for scaling function corr(lat) used to encode target longitude	54
Table 5.53: Definition of offset encoding fields	55
Table 5.54: FIS-B message identifier encoding	57
Table 5.55: METAR message bit encoding	59
Table 5.56: METAR message field encoding	60
Table 5.57: Encoding for ICAO Weather codes	65
Table 5.57a: Free text 6-bit character encoding (converted from ASCII 8-bit)	66
Table 5.58: ATIS message bit encoding	67
Table 5.59: ATIS message field encoding	68
Table 5.60: RCN message bit encoding	70
Table 5.61: RCN message field encoding	70
Table 5.62: SIGMET message bit encoding	73
Table 5.63: SIGMET message field encoding	74
Table 5.64: TSA message fixed field bit encoding	75
Table 5.65: TSA message bit encoding for area Control Zone	75

Table 5.66: TSA message bit encoding for Restricted, Danger, or Prohibited area	75
Table 5.67: TSA message field encoding.....	76
Table 5.68: FIS-B report request message bit encoding.....	78
Table 5.69: FIS-B report request message field encoding.....	78
Table 5.70: GNS-B message identifier (gmi).....	79
Table 5.71: GNS-B Message Type 1 bit encoding.....	80
Table 5.72: GNS-B Message Type 1 field encoding.....	81
Table 5.73: GNS-B message type 2 bit encoding.....	84
Table 5.74: GNS-B message type 2 field encoding.....	85
Table 5.75: GNS-B message type 4 bit encoding.....	87
Table 5.76: GNS-B message type 4 field encoding.....	89
Table 5.77: GPS Satellite ephemeris mask.....	95
Table 7.1: Protocol test-suite overview	98
Table 7.2: Subfield mnemonics.....	101
Table 7.3: Void.....	106
Table 7.4: Key to CPR encoding table in following clause.....	106
Table 7.5: Table of test values for CPR position report encoding CPR_ENC_TABLE (row, column) (CE(r, c))	107
Table 7.6: CPR test value tolerances.....	110
Table 7.7: Key to CPR decoding table in following clause.....	111
Table 7.8: Table of test values for CPR position report decoding CPR_DEC_TABLE (row, column) (CD(r, c)).....	112
Table 7.9: Values for use in the test "ADSB_DOS_A".....	115
Table 7.10: Values for use in the test "ADSB_Channel_A"	116
Table 7.11: Values for use in the test "ADSB_Channel_D"	118
Table 7.12: Values for use in the test "ADSB_Basic_Ground_A".....	121
Table 7.13: Values for use in the test "ADSB_UTC_Time_A"	122
Table 7.14: Values for use in the test "ADSB_Basic_Rec_A".....	123
Table 7.15: Values for use in the test "ADSB_High_Dynamic_Rec_A"	124
Table 7.16: Values for use in the test "ADSB_Full_Position_Rec_A"	125
Table 7.17: Values for use in the test "ADSB_Two_Slot_TCP/SVQ_Rec_A"	126
Table 7.18: Values for use in the test "ADSB_Single_Slot_TCP_Rec_A".....	129
Table 7.19: Values for use in the test "ADSB_Single_Slot_SVQ_Rec_A"	130
Table 7.20: Values for use in the test "ADSB_Aircraft_Data_Rec_A"	131
Table 7.21: Values for use in the test "ADSB_High_Resolution_Rec_A"	131
Table 7.22: Values for use in the test "TIS_Manage_A"	132
Table 7.23: Values for use in the test "TIS_Aircraft_Air_A"	133

Table 7.24: Values for use in the test "TIS_Aircraft_Grd_A"	134
Table 7.25: Values for use in the test "TIS_Grd_Veh_A"	135
Table 7.26: Values for use in the test "FIS_METAR_A"	136
Table 7.27: Values for use in the test "FIS_SPECI_A"	138
Table 7.28: Values for use in the test "FIS_ATIS_A"	140
Table 7.29: Values for use in the test "FIS_RCN_A"	142
Table 7.30: Values for use in the test "FIS_SIGMET_A"	143
Table 7.31: Values for use in the test "FIS_TSA_CTR_A"	143
Table 7.32: Values for use in the test "FIS_TSA_DNG_A"	144
Table 7.33: Values for use in the tests "FIS_Request_Rec_A" and "FIS_Request_Rec_B"	144
Table 7.34: Values for use in the test "GNS_Type1_Message_A"	145
Table 7.35: Values for use in the test "GNS_Type2_Message_A"	146
Table 7.36: Values for use in the test "GNS_Type4_Message_A"	147
Table 7.37: DIR_REQ_a (Da): Contains general request	149
Table 7.38: DIR_SYNC_BURST_a (DSa): Directed sync burst. Occupies one slot. Basic variable part	150
Table 7.39: PLEA_a (Pa): Information field contains destination address. Fits within delayed burst	150
Table 7.40: PLEA_RESP_a (PRa): Directed request with pr_flag = 1, nr ≠ "special"	151
Table 7.41: ADSB_REQUEST_a (ARa): Includes unicast reservation, sleep = 0, auto = 0	151
Table 7.42: ADSB_REQUEST_b (ARb): Includes unicast reservation, sleep = 0, auto = 1	152
Table 7.43: ADSB_REQUEST_c (ARc): Includes directed request reservation, sleep = 1, auto = 0	152
Table 7.44: ADSB_REQUEST_d (ARd) Includes directed request reservation, sleep = 1, auto = 1	153
Table 7.45: ADSB_REQUEST_e (ARe) Includes directed request reservation, sleep = 0, auto = 1	153
Table 7.46: DIR_SYNC_BURST_b (DSb): Directed sync burst. Occupies one slot. Full position variable part	154
Table 7.47: DIR_SYNC_BURST_c (DSc): Directed sync burst. Occupies one slot. Two-slot TCP variable part	155
Table 7.48: DIR_SYNC_BURST_d (DSd): Directed sync burst. Occupies one slot. High dynamic variable part	156
Table 7.49: CTRL_CHAN_k (CCK): Channel management burst with 1 header, 1 destination, 1 transmission, 1 frequency, 1 parameter and 1 script block	157
Table 7.50: CTRL_CHAN_p (CCp): Channel management burst with 1 header, a regional multicast, 1 transmission, 1 frequency, 1 parameter and 1 script block	158
Table 7.51: SYNC_BASIC_a (SBa): Basic variable part. Occupies one slot	160
Table 7.52: SYNC_HIGH_DYNAMIC_a (SHa): High dynamic variable part. Occupies one slot	161
Table 7.53: SYNC_FULL_POSITION_a (SPa): Full Position variable part. Occupies one slot	162
Table 7.54: SYNC_BASIC_GROUND_a (BGa): Basic Ground variable part. Occupies one slot	163
Table 7.55: SYNC_UTC_TIME_a (UTCa): UTC Time variable part. Occupies one slot	164
Table 7.56: SYNC_TWO_SLOT_TCP/SVQ_a (STa): Two-slot TCP variable part. Occupies two slots	165
Table 7.57: SYNC_SINGLE_SLOT_TCP_a (SSa): Single Slot TCP variable part. Occupies one slot	166

Table 7.58: SYNC_SINGLE_SLOT_SVQ_a (SVa): Single Slot SVQ variable part. Occupies one slot	167
Table 7.59: SYNC_AIRCRAFT_DATA_a (SDa): Aircraft data variable part. Occupies one slot.....	168
Table 7.60: SYNC_HIGH_RESOLUTION_a (SRa): High resolution variable part. Occupies one slot	169
Table 7.61: CTRL_DOS_a (CDa): Directory of Service(DOS) message. Fits within one slot.....	170
Table 7.62: TIS_MAN_a (TMa): Management message with response reservation	171
Table 7.63: TIS_AC_AIR_a (TAa): Aircraft target message (airborne TIV) with response reservation.....	172
Table 7.64: TIS_AC_GRD_a (TGa): Aircraft target message (ground TIV) with response reservation	173
Table 7.65: TIS_GRD_VEH_a (TVa): Ground vehicle target message with response reservation	174
Table 7.66: FIS_METAR_a (FMa): METAR message with response reservation	175
Table 7.67: FIS_SPECI_a (FSa): SPECI message with response reservation.....	176
Table 7.68: FIS_ATIS_a (FAa): ATIS message with response reservation.....	177
Table 7.69: FIS_RCN_A (FRa): RCN message burst format with response reservation.....	178
Table 7.70: FIS_SIGMET_a (FSa): SIGMET message with response reservation.....	179
Table 7.71: FIS_TSA_CTR_a (FTCa): TSA CTR Zone message with response reservation.....	180
Table 7.72: FIS_TSA_DNG_a (FTDa): TSA DNG Zone message with response reservation.....	181
Table 7.73: FIS_REQUEST_a (FQa): Request message with a null reservation.....	181
Table 7.74: FIS_REQUEST_b (FQb): Request message with a unicast reservation	182
Table 7.75: FIS_REQUEST_c (FQc): Request message with a response reservation	182
Table 7.76: FIS_REQUEST_d (FQd): Request message with a broadcast unicast reservation	183
Table 7.77: GNS_TYPE1_a (G1a): GNS-B Type 1 message with response reservation.....	184
Table 7.78: GNS_TYPE2_a (G2a): GNS-B Type 2 message with response reservation.....	185
Table 7.79: GNS_TYPE4_a (G4a): GNS-B Type 4 message with response reservation.....	187
Table A.1: VDL Mode 4 requirements for ADS-B	246
Table A.2: VDL Mode 4 requirements for TIS-B	249
Table A.3: VDL Mode 4 requirements for FIS-B	252
Table A.4: VDL Mode 4 requirements for GNS-B	255

History

Document history		
V1.1.1	February 2005	Publication
V1.2.1	July 2006	One-step Approval Procedure OAP 20061124: 2006-07-26 to 2006-11-24