

ETSI EN 301 842-1 V1.4.1 (2015-04)



EUROPEAN STANDARD

**VHF air-ground Digital Link (VDL) Mode 4 radio equipment;
Technical characteristics and methods of measurement
for ground-based equipment;
Part 1: EN for ground equipment**

Reference

REN/AERO-00020-1

Keywords

aeronautical, digital, radio, testing, VHF

ETSI

650 Route des Lucioles
F-06921 Sophia Antipolis Cedex - FRANCE

Tel.: +33 4 92 94 42 00 Fax: +33 4 93 65 47 16

Siret N° 348 623 562 00017 - NAF 742 C
Association à but non lucratif enregistrée à la
Sous-Préfecture de Grasse (06) N° 7803/88

Important notice

The present document can be downloaded from:

<http://www.etsi.org/standards-search>

The present document may be made available in electronic versions and/or in print. The content of any electronic and/or print versions of the present document shall not be modified without the prior written authorization of ETSI. In case of any existing or perceived difference in contents between such versions and/or in print, the only prevailing document is the print of the Portable Document Format (PDF) version kept on a specific network drive within ETSI Secretariat.

Users of the present document should be aware that the document may be subject to revision or change of status. Information on the current status of this and other ETSI documents is available at

<http://portal.etsi.org/tb/status/status.asp>

If you find errors in the present document, please send your comment to one of the following services:

<https://portal.etsi.org/People/CommitteeSupportStaff.aspx>

Copyright Notification

No part may be reproduced or utilized in any form or by any means, electronic or mechanical, including photocopying and microfilm except as authorized by written permission of ETSI.

The content of the PDF version shall not be modified without the written authorization of ETSI.

The copyright and the foregoing restriction extend to reproduction in all media.

© European Telecommunications Standards Institute 2015.

All rights reserved.

DECT™, **PLUGTESTS™**, **UMTS™** and the ETSI logo are Trade Marks of ETSI registered for the benefit of its Members. **3GPP™** and **LTE™** are Trade Marks of ETSI registered for the benefit of its Members and of the 3GPP Organizational Partners.

GSM® and the GSM logo are Trade Marks registered and owned by the GSM Association.

Contents

Intellectual Property Rights	6
Foreword.....	6
Modal verbs terminology.....	6
Introduction	7
1 Scope	8
2 References	9
2.1 Normative references	9
2.2 Informative references.....	10
3 Definitions and abbreviations.....	10
3.1 Definitions.....	10
3.1.1 Basic reference model definitions.....	10
3.1.2 Service conventions definitions	10
3.1.3 General definitions.....	11
3.2 Abbreviations	14
4 General description and architecture of VDL Mode 4	15
4.1 General	15
5 VDL Mode 4 physical layer functional specifications	15
5.1 Overview	15
5.1.1 Functions	16
5.1.2 Data reception.....	16
5.1.3 Data transmission.....	16
5.2 Modulation scheme	16
6 VDL Mode 4 equipment requirements.....	16
6.1 Receiver Requirements.....	16
6.1.1 Receiver operating range	16
6.1.2 BER requirement	16
6.1.3 Reference signal level.....	17
6.1.4 Sensitivity	17
6.1.5 Adjacent channel rejection.....	17
6.1.6 Rejection of signals within the VHF Aeronautical band.....	17
6.1.7 Rejection of signals outside the VHF Aeronautical band	17
6.1.8 Desired signal dynamic range.....	18
6.1.9 Symbol rate capture range	18
6.1.10 Frequency capture range.....	18
6.1.11 Co-channel interference	18
6.1.12 Conducted spurious emission	18
6.1.13 FM Broadcast Intermodulation.....	18
6.1.13.1 Radio frequencies in the band 112 MHz to 137 MHz.....	18
6.1.14 In-band Intermodulation	19
6.1.15 Cabinet radiation.....	19
6.2 Transmitter requirements	19
6.2.1 Transmitter operating range.....	19
6.2.2 Channel Bit Rate.....	19
6.2.3 Protection of the transmitter.....	20
6.2.4 Manufacturer's declared output power.....	20
6.2.5 RF power rise time.....	20
6.2.6 RF power release time	20
6.2.7 Conducted Spurious emissions	20
6.2.8 Adjacent channel power.....	20
6.2.9 Wide-band noise	21
6.2.10 Frequency Tolerance.....	21
6.2.11 Load VSWR capability.....	21
6.2.12 Cabinet radiation.....	21

6.3	Transceiver requirements	21
6.3.1	Start of transmission	21
6.3.2	Automatic transmitter shutdown	21
6.3.3	Receiver to transmitter turnaround time	21
6.3.4	Transmitter to receiver turnaround time	21
6.3.5	System timing requirements	21
7	General design requirements	22
7.1	Controls and indicators	22
7.2	Class of emission and modulation characteristics	22
7.3	Warm up	22
8	Test conditions, power sources and ambient temperatures	22
8.1	Test power source	22
8.2	Test channels	22
8.3	General conditions of measurement	22
8.3.1	Receiver test signal arrangement	22
8.3.2	Performance check	22
8.4	Normal and extreme test conditions	23
8.4.1	Normal test conditions	23
8.4.1.1	Normal temperature and humidity	23
8.4.1.2	Normal power sources	23
8.4.1.2.1	Mains voltage and frequency	23
8.4.1.2.2	Other power sources	23
8.4.2	Extreme test conditions	23
8.4.2.1	Extreme temperatures	23
8.4.2.2	Procedure for tests at extreme temperatures	23
8.4.2.2.1	General	23
8.4.2.2.2	High temperature	23
8.4.2.2.3	Low temperature	24
8.4.2.3	Extreme values of test power sources	24
8.4.2.3.1	Mains voltage and frequency	24
9	Detailed Test Procedures for the physical layer	24
9.1	Receiver	24
9.1.1	BER test	24
9.1.2	Sensitivity	26
9.1.3	Adjacent Channel Rejection (ACR)	26
9.1.4	Rejection of signals within the VHF Aeronautical band	27
9.1.5	Rejection of signals outside the VHF Aeronautical band	28
9.1.6	Desired Signal dynamic range	29
9.1.7	Symbol rate capture range	29
9.1.8	Frequency capture range	30
9.1.9	Co-channel interference	30
9.1.10	Conducted spurious emission	31
9.1.11	In-band Intermodulation	31
9.2	Transmitter	32
9.2.1	Channel Bit Rate	32
9.2.2	Manufacturer's declared output power	32
9.2.3	RF power rise time	33
9.2.4	RF power release time	33
9.2.5	Spurious emissions	34
9.2.6	Adjacent channel power	34
9.2.6.1	Method of measurement for the first adjacent channel	34
9.2.6.2	Method of measurement for the second adjacent channel	35
9.2.6.3	Method of measurement for the fourth adjacent channel	36
9.2.6.4	Alternative measurement procedure for Adjacent Channel Power (ACP)	37
9.2.7	Wide-band noise	37
9.2.8	Frequency Error	38
9.2.8.1	Definition	38
9.2.8.2	Method of measurement	38
9.2.8.3	Limits	38
9.2.9	Load VSWR capability	38

9.3	Physical layer, system parameters	39
9.3.1	Receiver to Transmitter turn-around time.....	39
9.3.2	Transmitter to Receiver turn-around time.....	39
9.3.3	Tuning Time	40
Annex A (informative):	Cross reference matrix	41
Annex B (informative):	Bibliography.....	43
History		44

Intellectual Property Rights

IPRs essential or potentially essential to the present document may have been declared to ETSI. The information pertaining to these essential IPRs, if any, is publicly available for **ETSI members and non-members**, and can be found in ETSI SR 000 314: "*Intellectual Property Rights (IPRs); Essential, or potentially Essential, IPRs notified to ETSI in respect of ETSI standards*", which is available from the ETSI Secretariat. Latest updates are available on the ETSI Web server (<http://ipr.etsi.org>).

Pursuant to the ETSI IPR Policy, no investigation, including IPR searches, has been carried out by ETSI. No guarantee can be given as to the existence of other IPRs not referenced in ETSI SR 000 314 (or the updates on the ETSI Web server) which are, or may be, or may become, essential to the present document.

Foreword

This European Standard (EN) has been produced by ETSI Technical Committee Aeronautics (AERO).

The present document is part 1 of a multi-part deliverable covering the VHF air-ground Digital Link (VDL) Mode 4 radio equipment; Technical characteristics and methods of measurement for ground-based equipment, as identified below:

- Part 1: "EN for ground equipment";
- Part 2: "General description and data link layer";
- Part 3: "Additional broadcast aspects";
- Part 4: "Point-to-point functions";
- Part 5: "Harmonized EN covering the essential requirements of article 3.2 of the R&TTE Directive".

The present document is accompanied by an equivalent airborne standard, ETSI EN 302 842 [i.1] parts 1 to 4, covering the VHF air-ground Digital Link (VDL) Mode 4 radio equipment; Technical characteristics and methods of measurement for airborne equipment.

National transposition dates	
Date of adoption of this EN:	6 April 2015
Date of latest announcement of this EN (doa):	31 July 2015
Date of latest publication of new National Standard or endorsement of this EN (dop/e):	31 January 2016
Date of withdrawal of any conflicting National Standard (dow):	31 January 2017

Modal verbs terminology

In the present document "**shall**", "**shall not**", "**should**", "**should not**", "**may**", "**need not**", "**will**", "**will not**", "**can**" and "**cannot**" are to be interpreted as described in clause 3.2 of the [ETSI Drafting Rules](#) (Verbal forms for the expression of provisions).

"**must**" and "**must not**" are **NOT** allowed in ETSI deliverables except when used in direct citation.

Introduction

The present document states the technical specifications for Very High Frequency (VHF) Digital Link (VDL) Mode 4 ground-based radio transmitters, transceivers and receivers for air-ground communications operating in the VHF band, using Gaussian-filtered Frequency Shift Keying (GFSK) Modulation with 25 kHz channel spacing and capable of tuning to any of the 25 kHz channels from 112,000 MHz to 136,975 MHz as defined in ICAO VHF Digital Link (VDL) Standards and Recommended Practices (SARPs) [2].

The present document may be used to produce tests for the assessment of the performance of the equipment.

1 Scope

The present document applies to the following radio equipment types:

- Very High Frequency (VHF) Digital Link (VDL) Mode 4 ground-based radio transmitters and receivers for air-ground communications operating in the VHF band, using Gaussian-filtered Frequency Shift Keying (GFSK) Modulation with 25 kHz channel spacing and capable of tuning to any of the 25 kHz channels from 112,000 MHz to 136,975 MHz as defined in ICAO VHF Digital Link (VDL) Standards and Recommended Practices (SARPs) [2].

The present document provides part 1 of the technical specification.

The present document is designed to ensure that equipment certified to it will be compatible with the relevant ICAO VHF Digital Link (VDL) Standards and Recommended Practices (SARPs) [2] and VDL Mode 4 Technical Manual (TM) [1].

Manufacturers should note that in future the tuning range for the ground transceivers may also cover any 25 kHz channel from 108,000 MHz to 111,975 MHz.

The scope of the present document is limited to ground stations. The equivalent specification for airborne stations is ETSI EN 302 842 [i.1].

The VDL Mode 4 system provides digital communication exchanges between aircraft and ground-based systems and other aircraft supporting surveillance and communication applications. The supported modes of communication include:

- broadcast and point-to-point communication;
- broadcast services including Automatic Dependent Surveillance-broadcast (ADS-B), Traffic Information Service - Broadcast (TIS-B) and Flight Information Service - Broadcast (FIS-B) capabilities;
- air-air, air-to-ground, and ground-to-air services;
- operation without ground infrastructure.

The present document is derived from the specifications:

- VDL Mode 4 standards produced under the auspices of the International Civil Aviation Organization (ICAO) [1] and [2];
- other relevant standards as defined in clause 2.

It is envisaged that manufacturers may provide equipment supporting:

- broadcast services only;
- point-to-point services only;
- both broadcast and point-to-point services.

The present document deals with tests of the physical layer necessary to support all types of equipment.

The present document includes:

- clause 2 provides references to relevant documents;
- clause 3 provides general definitions, abbreviations and symbols used;
- clause 4 refers to a general description and architecture of VDL Mode 4 contained in ETSI EN 301 842-2 [6];
- clause 5 provides functional specifications applicable to the physical layer including transmitter/receiver requirements and the modulation scheme;
- clause 6 provides general equipment requirements;
- clause 7 provides general design requirements;

- clause 8 covers general test conditions, environmental tests and calibration;
- clause 9 provides detailed test procedures for the physical layer;
- annex A provides a detailed cross-reference to the relevant requirements contained in reference [1];
- annex B provides a Bibliography;

The full physical layer tests are provided which correspond closely to the standard set of tests used for other VDL systems.

Mandating and Recommendation Phrases

- a) **"Shall"**
The use of the word "Shall" indicates a mandated criterion; i.e. compliance with the particular procedure or specification is mandatory and no alternative may be applied.
- b) **"Should"**
The use of the word "Should" (and phrases such as "It is recommended that...", etc.) indicate that though the procedure or criterion is regarded as the preferred option, alternative procedures, specifications or criteria may be applied, provided that the manufacturer, installer or tester can provide information or data to adequately support and justify the alternative.

2 References

2.1 Normative references

References are either specific (identified by date of publication and/or edition number or version number) or non-specific. For specific references, only the cited version applies. For non-specific references, the latest version of the reference document (including any amendments) applies.

Referenced documents which are not found to be publicly available in the expected location might be found at <http://docbox.etsi.org/Reference>.

NOTE: While any hyperlinks included in this clause were valid at the time of publication, ETSI cannot guarantee their long term validity.

The following referenced documents are necessary for the application of the present document.

- [1] ICAO Doc 9816 (First Edition 2004): "Manual on VHF Digital Link (VDL) Mode 4, Part 2: Detailed Technical Specifications".
- [2] ICAO Annex 10 to the Convention on International Civil Aviation: "Aeronautical Telecommunications, Volume III: Communication Systems, Part I: Digital Data Communication Systems, chapter 6", including Amendment 88 (applicable 14/11/13).
- [3] ISO/IEC 7498-1 (1994): "Information technology - Open Systems Interconnection - Basic Reference Model: The Basic Model".
- [4] ISO/IEC 10731 (1994): "Information technology - Open Systems Interconnection - Basic Reference Model - Conventions for the definition of OSI services".
- [5] ETSI EN 300 113-1 (V1.7.1): "Electromagnetic compatibility and Radio spectrum Matters (ERM); Land mobile service; Radio equipment intended for the transmission of data (and/or speech) using constant or non-constant envelope modulation and having an antenna connector; Part 1: Technical characteristics and methods of measurement".
- [6] ETSI EN 301 842-2 (V1.7.1): "VHF air-ground Digital Link (VDL) Mode 4 radio equipment; Technical characteristics and methods of measurement for ground-based equipment; Part 2: General description and data link layer".

2.2 Informative references

References are either specific (identified by date of publication and/or edition number or version number) or non-specific. For specific references, only the cited version applies. For non-specific references, the latest version of the reference document (including any amendments) applies.

NOTE: While any hyperlinks included in this clause were valid at the time of publication, ETSI cannot guarantee their long term validity.

The following referenced documents are not necessary for the application of the present document but they assist the user with regard to a particular subject area.

- [i.1] ETSI EN 302 842 (all parts): "VHF air-ground and air-air Digital Link (VDL) Mode 4 radio equipment; Technical characteristics and methods of measurement for aeronautical mobile (airborne) equipment".

3 Definitions and abbreviations

3.1 Definitions

3.1.1 Basic reference model definitions

The present document is based on the concepts developed in the open systems interconnect basic reference model and makes use of the following terms defined in ISO/IEC 7498-1 [3]:

- layer;
- sublayer;
- entity;
- service;
- service access point;
- service data unit;
- physical layer;
- data link layer.

3.1.2 Service conventions definitions

The present document makes use of the following terms defined in ISO/IEC 10731 [4]:

- service provider;
- service user;
- service primitive;
- request;
- indication;
- confirm.

3.1.3 General definitions

For the purposes of the present document, the following terms and definitions apply:

adjacent channel power: amount of the modulated RF signal power which falls within a given adjacent channel

NOTE: Adjacent channel power includes discrete spurious, signal sidebands, and noise density (including phase noise) at the transmitter output.

Adjacent Channel Rejection (ACR): receiver's ability to demodulate the desired signal and meet the BER requirement in the presence of an interfering signal in an adjacent channel

NOTE: The ratio (in dB) between the adjacent interfering signal level and the desired signal level necessary to achieve the specified minimum BER, is the adjacent channel rejection (ACR) ratio.

Aeronautical Mobile Service (AMS): mobile service between aeronautical stations and aircraft stations, or between aircraft stations, in which survival craft stations may participate

Aeronautical Telecommunications Network (ATN): internetwork architecture that allows ground, air/ground, and aircraft data subnetworks to interoperate by adopting common interface services and protocols based on the International Organization for Standardization Open Systems Interconnection (OSI) Reference Model

aircraft address: unique combination of 24 bits available for assignment to an aircraft for the purpose of air-ground communications, navigation and surveillance

NOTE: An aircraft may choose not to use this unique address and can use instead a non-unique address.

Automatic Dependent Surveillance-Broadcast (ADS-B): surveillance application transmitting parameters, such as position, track and ground speed, via a broadcast mode data link for use by any air and ground users requiring it

NOTE: ADS-B is a surveillance service based on aircraft self-determination of position/velocity/time and automatic, periodic or random, broadcast of this information along with auxiliary data such as aircraft identity (ID), communications control parameters, etc. ADS-B is intended to support multiple high-level applications and associated services such as cockpit display of traffic information, traffic alert and collision avoidance functionality, enhanced traffic management in the air and on the ground, search and rescue support and others.

autotune function: function, performed by the Link Management Entity, that allows a ground VDL Mode 4 station to command an aircraft to change the operating characteristics of synchronization burst transmissions

Bit Error Rate (BER): expressed as the ratio between the number of erroneous bits received and the total number of bits received

burst length: number of slots across which the VDL Mode 4 burst is transmitted

Co-Channel Interference (CCI): co-channel interference protection defines the capability of a receiver to demodulate the desired signal and achieve the minimum specified BER performance in the presence of an unwanted signal at the same assigned frequency

NOTE: The ratio (in dB) between the wanted signal level and the unwanted signal level is the co-channel interference ratio. The co-channel interference ratio has a major impact on frequency re-use planning criteria.

conducted measurements: measurements which are made using a direct RF connection to the equipment under test

current slot: slot in which a received transmission begins

Data Link Entity (DLE): protocol state machine capable of setting up and managing a single data link connection

Data Link Service (DLS) sublayer: sublayer that resides above the VDL Mode 4 Specific Services (VSS) and the MAC sublayers

NOTE: The Data Link Service (DLS) manages the transmit queue, creates and destroys Data Link Entities (DLEs) for connection-oriented communications, provides facilities for the Link Management Entity (LME) to manage the DLS, and provides facilities for connection-less communications.

data rate: Mode 4 nominal data rate is 19 200 bits/s

delayed burst: VDL Mode 4 burst that begins sufficiently after the beginning of a slot so that the transmitting VDL Mode 4 station is confident that no other VDL Mode 4 station that it could receive from and is within the guard range is transmitting in the slot

NOTE: The delayed VDL Mode 4 burst terminates by the end of the slot in which it began (its length is shortened to ensure completion by the nominal time).

DLS system: VDL system that implements the DLS and subnetwork protocols to carry Aeronautical Telecommunications Network (ATN) or other packets

frame: link layer frame is composed of a sequence of address, control, information and FCS fields, bracketed by opening and closing flag sequences

NOTE: A valid frame is at least 11 octets in length and contains an address field (8 octets), a link control field (1 octet) and a frame check sequence (2 octets). A frame may or may not include a variable-length information field.

Global Signalling Channel (GSC): channel available on a world wide basis which provides for communication control

ground base station: aeronautical station equipment, in the aeronautical mobile service, for use with an external antenna and intended for use at a fixed location

ground station coordination: coordination of transmissions from two or more ground stations uses the UTC-minute time frame

hand held: radio equipment with integral batteries, designed to be hand portable and operated hand held

NOTE: Provisions may be made for external connections and temporary installation into vehicles.

integral antenna equipment: radio communications equipment with an antenna integrated into the equipment without the use of an external connector and considered to be part of the equipment

NOTE: An integral antenna may be internal or external to the equipment. In equipment of this type, a 50 Ω RF connection point should be provided for test purposes.

link: connects a mobile DLE and a ground DLE and is uniquely specified by the combination of mobile DLS address and the ground DLS address

NOTE: A different subnetwork entity resides above every link endpoint.

link establishment: process by which two stations discover each other, determine to communicate with each other, decide upon the communication parameters, create a link and initialize its state before beginning communications

link handoff: process by which peer LMEs, already in communication with each other, create a link between an aircraft and a new ground station before disconnecting the old link between the aircraft and the current ground station

link layer: layer that lies immediately above the physical layer in the Open Systems Interconnection protocol model

NOTE: The link layer provides for the reliable transfer of information across the physical media. It is subdivided into the data link sublayer and the media access control sublayer.

Link Management Entity (LME): protocol state machine capable of acquiring, establishing, and maintaining a connection to a single peer system

NOTE: An LME establishes data link and subnetwork connections, "hands-off" those connections, and manages the media access control sublayer and physical layer. An aircraft LME tracks how well it can communicate with the ground stations of a single ground system. An aircraft VDL management entity (VME) instantiates an LME for each ground station that it monitors. Similarly, the ground VME instantiates an LME for each aircraft that it monitors. An LME is deleted when communication with the peer system is no longer viable.

Media Access Control (MAC): sublayer that acquires the data path and controls the movement of bits over the data path

mobile: radio equipment designed for installation into vehicles

non-integral antenna equipment: radio communications equipment with a connector intended for connection to an antenna

physical layer: lowest level layer in the Open Systems Interconnection protocol model

NOTE: The physical layer is concerned with only the transmission of binary information over the physical medium (e.g. VHF radio).

primary time source: normal operation timing mode in which a VDL Mode 4 station maintains time synchronization to Universal Coordinated Time (UTC) second to within a two-sigma value of 400 ns

private parameters: parameters that are contained in exchange identity (XID) frames and that are unique to the VHF digital link environment

radiated measurements: measurements which involve the measurement of a radiated field

reference bit sequence: sequence of bits used in the transmitter performance specifications

reference signal level: signal level used in the receiver performance specifications except otherwise stated

secondary time source: timing source used in a failure mode, which applies when the primary time source fails, in which a VDL Mode 4 station maintains time synchronization to UTC second to within a two-sigma value of 15 μ s

Self-organizing Time Division Multiple Access (STDMA): multiple access scheme based on time-shared use of a radio frequency (RF) channel employing:

- 1) discrete contiguous time slots as the fundamental shared resource; and
- 2) a set of operating protocols that allows users to mediate access to these time slots without reliance on a master control station.

slot: In VDL Mode 4, time is divided into a series of time slots of equal period

NOTE: Each VDL Mode 4 burst transmission starts at the beginning of a slot.

station: VDL Mode 4 Specific Services (VSS)-capable entity

NOTE: A station may be either a mobile station or a ground station. A station is a physical entity that transmits and receives bursts over the RF interface (either A/G or Air-to-Air (A/A)) and comprises, at a minimum: a physical layer, media access control sublayer, and a unique VSS address. A station which is also a DLS station has the same address.

subnetwork layer: layer that establishes, manages, and terminates connections across a subnetwork

superframe: group of 4 500 slots that span a period of one UTC minute

NOTE: The start of the current superframe is aligned with the start of the slot that is currently being used for transmission. The next superframe starts one minute after the current slot.

synchronization burst (or "sync" burst): VDL Mode 4 burst which announces, as a minimum, existence and position

NOTE: Ground stations announce existence, position, and the current time. Mobile stations lacking timing information can then derive the slot structure from ground synchronization bursts. Mobile stations lacking position information can derive position from both mobile and ground synchronization bursts. This periodic information is used in various ways including ADS-B, secondary navigation, and simplifying the LME algorithms.

Time Division Multiple Access (TDMA): multiple access scheme based on time-shared use of an RF channel employing:

- 1) discrete contiguous time slots as the fundamental shared resource; and
- 2) a set of operating protocols that allows users to interact with a master control station to mediate access to the channel.

unicasted transmission: transmission addressed to a single station

VDL Management Entity (VME): VDL-specific entity that provides the quality of service requested by the ATN-defined subnetwork system management entity

NOTE: A VME uses the LMEs (that it creates and destroys) to acquire the quality of service available from peer systems.

VDL Mode 2: VHF data link using a differentially encoded 8 phase shift keying modulation scheme and carrier sense multiple access

VDL Mode 4: VHF data link using a Gaussian-filtered Frequency Shift Keying (GFSK) modulation scheme and self organizing time division multiple access

VDL Mode 4 burst: sequence of source address, burst ID, information, slot reservation, and Frame Check Sequence (FCS) fields, bracketed by opening and closing flag sequences, and preceded by a preamble

NOTE 1: The start of a burst may occur only at quantized time intervals and this constraint allows the propagation delay between the transmission and reception to be derived.

NOTE 2: The burst definitions contained within the present document consider the link layer data only (and exclude the preamble).

VDL Mode 4 Specific Services (VSS) sublayer: sublayer that resides above the MAC sublayer and provides VDL Mode 4 specific access protocols including reserved, random and fixed protocols

VSS user: user of the VDL Mode 4 Specific Services

NOTE: The VSS user could be higher layers in the VDL Mode 4 Technical Manual or an external application using VDL Mode 4.

VDL Mode 4 station: physical entity that transmits and receives VDL Mode 4 bursts over the RF interface (either A/G or Air-to-Air (A/A)) and comprises, as a minimum: a physical layer, Media Access Control (MAC) sublayer and a VSS sublayer

NOTE: A VDL Mode 4 station may either be a mobile VDL Mode 4 station or a ground VDL Mode 4 station.

VDL Mode 4 Station Address: 27-bit identifier used to uniquely identify a VDL Mode 4 station

VDL Station: VDL-capable entity

NOTE: A station may either be a mobile station or a ground station. A station is a physical entity that transmits and receives frames over the air/ground (A/G) interface and comprises, at a minimum: a physical layer, media access control sublayer, and a unique DLS address. The particular initiating process (i.e. DLE or LME) in the station cannot be determined by the source DLS address. The particular destination process cannot be determined by the destination DLS address. These can be determined only by the context of these frames as well as the current operational state of the DLEs.

VDL System: VDL-capable entity

NOTE: A system comprises one or more stations and the associated VDL management entity. A system may either be a mobile system or a ground system.

3.2 Abbreviations

For the purposes of the present document, the following abbreviations apply:

A/A	Air-to-Air
A/G	Air/Ground
ACP	Adjacent Channel Protection
ACR	Adjacent Channel Rejection
ADS-B	Automatic Dependent Surveillance-Broadcast
AMS	Aeronautical Mobile Service
ATN	Aeronautical Telecommunication Network
AWG	Arbitrary Waveform Generator

BER	Bit Error Rate
Br	resolution bandwidth
BT	Bandwith Time
Bv	video bandwidth
CCI	Co-Channel Interference
CRC	Cyclic Redundancy Check
dB	deciBel
dBm	deciBels with respect to 1mW
DLE	Data Link Entity
DLS	Data Link Service
DSB-AM	Dependent Surveillance Broadcast-Amplitude Modulation
FCS	Frame Check Sequence
FIS-B	Flight Information Service - Broadcast
FM	Frequency Modulation
GFSK	Gaussian-filtered Frequency Shift Keying
GSC	Global Signalling Channel
ICAO	International Civil Aviation Organization
ID	IDentity
IF	Intermediate Frequency
ISO	International Organization for Standardization
LME	Link Management Entity
MAC	Media Access Control
MER	Message Error Rate
NM	Nautical Mile
NRZI	Non-Return to Zero Inverted
ns	nanoseconds
OSI	Open Systems Interconnection
PC	Personal Computer
ppm	parts per million
R&TTE	Radio equipment and Telecommunications Terminal Equipment
RF	Radio Frequency
Rx	Receiving
SARPs	Standards And Recommended Practices
STDMA	Self-organizing Time Division Multiple Access
TDMA	Time Division Multiple Access
TIS-B	Traffic Information Service - Broadcast
TM	Technical Manual
Tx	Transmitting
UTC	Universal Coordinated Time
VDL	VHF Digital Link
VHF	Very High Frequency
VME	VDL Management Entity
VSS	VDL Mode 4 Specific Services
VSWR	Voltage Standing Wave Ratio
XID	eXchange IDentity (frame)

4 General description and architecture of VDL Mode 4

4.1 General

A description of VDL Mode 4, the communication services provided, equipment classes, the structure of the standards material and guidance on equipment performance verification is provided in ETSI EN 301 842-2 [6], clause 4.

5 VDL Mode 4 physical layer functional specifications

5.1 Overview

The ground stations shall access the physical layer operating in duplex mode.

5.1.1 Functions

The tasks of the physical layer shall include the following:

- to modulate and demodulate radio carriers with a bit stream of a defined instantaneous rate to create an RF link;
- to acquire and maintain bit and burst synchronization between Transmitters and Receivers;
- to transmit or receive a defined number of bits at a requested time (packet mode) and on a particular carrier frequency;
- to measure received signal strength;
- to decide whether a channel is idle or busy, for the purposes of channel management;
- to offer a notification service about the quality of link.

5.1.2 Data reception

The receiver shall decode input signals and forward them to the higher layers for processing.

5.1.3 Data transmission

The VDL physical layer shall appropriately encode the data received from the data link layer and transmit it over the RF channel.

5.2 Modulation scheme

The modulation scheme shall be Gaussian-filtered Frequency Shift Keying (GFSK), which is a continuous-phase, frequency shift keying technique using two tones and a Gaussian pulse shape filter. The first bit transmitted (in the training sequence) shall be a high tone and the transmitted tone shall be toggled when transmitting a 0 (i.e. NRZI encoding). The training sequence shall be the 24 bit sequence 0101 0101 0101 0101 0101 0101. Binary *ones* and binary *zeros* shall be generated with a modulation index of $0,25 \pm 0,03$ and a BT product of $0,28 \pm 0,03$.

6 VDL Mode 4 equipment requirements

Unless otherwise stated, all specifications shall be met under room conditions, and under environmental conditions as specified in clause 8. Unless otherwise stated, all specifications shall be met at the nominal data rate, with the transceiver tuned to any 25 kHz channel within the range 112,000 MHz to 136,975 MHz.

6.1 Receiver Requirements

6.1.1 Receiver operating range

All receivers contained within a VDL Mode 4 transceiver shall be capable of tuning to any of the 25 kHz channels from 112,000 MHz to 136,975 MHz as defined in ICAO VDL SARPs [2]. Manufacturers should note that in future the tuning range for the receiver(s) may cover any 25 kHz channel from 108,000 MHz to 111,975 MHz.

6.1.2 BER requirement

For the purposes of the following requirements, the specified Bit Error Rate (BER) of the equipment shall be equal to or better than 1 in 10^4 .

NOTE 1: This requirement is derived from the assumed performance for VDL Mode 4 inferred from ICAO VDL SARPs [2].

NOTE 2: Manufacturers may alternatively propose to use a requirement based on a Message Error Rate (MER) which is shown by the manufacturer to be equivalent to the BER stated above taking account of burst transmission length. Further guidance is provided in clause 9.

NOTE 3: Proof that BER requirements are met may be carried out by measuring average performance for many separate transmissions rather than analysis of a single transmission (see clause 9.1.1).

6.1.3 Reference signal level

The reference signal level applied at the receiver input for all receiver requirements, unless otherwise stated, shall be minus 87 dBm in the frequency range 112,000 MHz to 136,975 MHz.

6.1.4 Sensitivity

A maximum signal level of minus 98 dBm from a modulated VDL Mode 4 signal source shall produce the BER requirement specified in clause 6.1.2 in the frequency range 112,000 MHz through 136,975 MHz.

6.1.5 Adjacent channel rejection

The minimum Adjacent Channel Rejection ratio (ACR) shall be determined in the presence of the reference signal level.

The ACR required to achieve the BER (clause 6.1.2) shall be equal to, or greater than, 32 dB, when tested using DSB-AM, VDL Mode 2 and VDL Mode 4 Type A undesired signals on each side of the wanted signal and at the nominal channel separation of 25 kHz from it.

NOTE: Nominal channel separation is defined as the difference in the assigned channel frequencies of the desired and undesired signals, e.g. a nominal channel separation of 25 kHz deals with the first adjacent channels above and below the assigned frequency of the desired signal.

6.1.6 Rejection of signals within the VHF Aeronautical band

The BER requirement (clause 6.1.2) shall be achieved when the wanted signal, set at the reference level, is combined with an unmodulated interfering signal in the following conditions:

- a) Level of the interfering signal set at minus 33 dBm at frequencies corresponding to centres of second and third adjacent channels.
- b) Level of the interfering signal set at minus 27 dBm at frequencies corresponding to centres of fourth adjacent channels.
- c) Level of the interfering signal set at minus 27 dBm at a separation of plus or minus 1 MHz from the nominal receiver frequency.

The frequency range of the interfering signal shall be 112,000 MHz to 136,975 MHz, including the frequencies equivalent to the second higher and second lower channels to which the receiver is tuned but excluding the frequency range between these two channels.

6.1.7 Rejection of signals outside the VHF Aeronautical band

The BER requirement (clause 6.1.2) shall be achieved when one of the specified unwanted signals specified below is applied in turn and in addition to the reference signal level (clause 6.1.3).

NOTE 1: The signals specified below are applied one at a time and not simultaneously.

Unwanted signal A:

Level: minus 33 dBm

Modulation: None

Frequency range: 108,000 MHz to 156,000 MHz (excluding 112,000 MHz to 137,025 MHz)

Unwanted signal B:

Level: minus 7 dBm
 Modulation: None
 Frequency range: 50 kHz to 1 215,000 MHz (excluding the range 87,500 MHz to 156,000 MHz)

NOTE 2: A maximum interfering level of minus 33 dBm is permitted at the receiver IF frequencies.

Unwanted signal C:

Level: minus 5 dBm
 Modulation: None
 Frequency range: 87,500 MHz to 107,900 MHz

NOTE 3: The frequency ranges should be swept at a rate not exceeding $1,5 \times 10^{-3}$ decades/s. Where the frequency range is swept incrementally, the step size should not exceed 1 % of the previous frequency.

6.1.8 Desired signal dynamic range

The receiver shall continue to achieve the BER requirement (clause 6.1.2) when the reference signal level is increased to a level of minus 7 dBm.

6.1.9 Symbol rate capture range

The BER requirement (clause 6.1.2) shall be achieved when the reference signal level is subject to a symbol rate offset of plus/minus 50 parts per million.

6.1.10 Frequency capture range

The receiver shall be capable of acquiring and maintaining a lock to any selected channel with the maximum permitted signal frequency offset.

The BER requirement (clause 6.1.2) shall be achieved when the reference signal level is subject to a frequency offset of plus/minus 826 Hz.

NOTE: This value is composed of the maximum transmitter frequency error at 136,975 MHz (± 685 Hz) and the maximum Doppler shift (± 141 Hz).

6.1.11 Co-channel interference

The BER requirement (clause 6.1.2) shall be achieved when a VDL Mode-4 interfering signal 12 dB below the reference signal is applied in addition to the reference signal level.

NOTE: The receiver should always prioritize the processing of the received signal with the highest power.

6.1.12 Conducted spurious emission

When the receiver input is terminated in a resistive load equal to the nominal receiver input impedance, the level of any spurious emission appearing across the load shall not exceed -57 dBm over the frequency range of 9 kHz to 1 GHz and -47 dBm over the frequency range of 1 GHz to 4 GHz, with the exception of the range of 108,000 MHz to 137,000 MHz, where it shall not exceed -64 dBm.

6.1.13 FM Broadcast Intermodulation**6.1.13.1 Radio frequencies in the band 112 MHz to 137 MHz**

The BER requirement (clause 6.1.2) shall be achieved in the presence of two unmodulated interfering signals within the frequency range of 87,500 MHz to 107,900 MHz. Each interfering signal shall separately present minus 5 dBm at the receiver input. The combined interfering signal shall be simultaneously applied to the receiver input in the presence of the reference signal.

6.1.14 In-band Intermodulation

The BER requirement (clause 6.1.2) shall be achieved in the presence of two interfering signals, displaced in frequency, from the desired signal.

Desired signal:

Level: minus 75 dBm
 Modulation: VDL Mode 4 modulation as defined in clause 5.2.

Unwanted signal A:

Level: minus 32 dBm
 Modulation: none
 Frequency: test frequency ± 1 MHz.

Unwanted signal B:

Level: minus 32 dBm
 Modulation: VDL Mode 4 modulation as defined in clause 5.2.
 Frequency: test frequency ± 2 MHz.

NOTE: Manufacturers should consider improving on the above values.

6.1.15 Cabinet radiation

The receiver shall meet the cabinet radiation requirements of ETSI EN 300 113-1 [5].

6.2 Transmitter requirements

All transmitter measurements should be made using conducted power unless otherwise stated.

NOTE 1: Unless otherwise stated, the test reference bit sequence is specified as follows: the maximum "transmit" period is determined by the maximum "burst" length permitted for VDL Mode 4 operation. This is a 16 slot message, giving a maximum burst length of 212,08 milliseconds (excluding guard time) at the nominal symbol rate of 19 200 symbols/s.

The minimum "off" period is determined assuming that the transmitter will at least leave a suitable guard range time at the end of transmission before starting a new transmission. The typical guard time used in VDL mode 4 is 1,25 milliseconds (for 200 NM guard range), which will therefore be taken as the minimum "off" period. The maximum duty cycle is therefore 212,08 milliseconds in "transmit" mode followed by 1,25 milliseconds "off".

NOTE 2: There is no requirement for simultaneous transmit and receive.

6.2.1 Transmitter operating range

The transmitter contained within a VDL Mode 4 transceiver shall be capable of being tuned to any of the 25 kHz channels in the range from 112,000 MHz to 136,975 MHz as defined in [2]. Manufacturers should note that in future the tuning range for the transmitter may also cover any 25 kHz channel from 108,000 MHz to 111,975 MHz.

6.2.2 Channel Bit Rate

The data rate shall be 19,2 kbit/s plus or minus 50 ppm.

NOTE: 50 ppm = 0,005 %.

6.2.3 Protection of the transmitter

The protection of the transmitter represents the ability of the transmitter to be protected against malfunction due to faults in the antenna system. Worst case mismatches, are represented by a short and open circuit test. The transmitter shall operate normally after the completion of the test.

6.2.4 Manufacturer's declared output power

The transmitter mean output power, measured at the output of the transmitter, shall be the manufacturer's stated maximum output power plus or minus 1 dB when delivered into a 50 Ω load, and measured during signal transmission (steady state power level), not averaged over the time intervals between signal transmissions.

NOTE: The power levels are measured at the output of the transmitter, not at the antenna.

For practical reasons, measurements shall be performed only at the lowest and the highest power output level at which the transmitter is intended to operate.

6.2.5 RF power rise time

The transmitter power stabilization segment shall have a duration of 832 microseconds. The transmitter power level at the end of the transmitter power stabilization segment shall be no less than 90 % of the mean output power level measured during signal transmission (steady state power level).

6.2.6 RF power release time

The transmitted power level shall decay at least by 20 dB below the manufacturer declared output power level within 300 microseconds after transmitting the final information symbol.

The transmitter power level shall be less than minus 90 dB below the manufacturer declared output power level within 832 microseconds after transmitting the final information symbol.

6.2.7 Conducted Spurious emissions

When the transmitter is "active" or "idle" (or the transceiver is in receive mode) and terminated in a matched impedance load, the power of any spurious emission at the output of the transmitter shall not exceed the values given in table 6.1.

Table 6.1: Spurious emissions power limits at transmitter output

Environmental phenomena	Frequency range	Units	Test limits, Tx Standby	Test limits Tx active mode	Reference bandwidth
Spurious conducted RF emissions	9 kHz to 150 kHz	dBm	-57 (2 nW)	-36 dBm	B = 1 kHz
Spurious conducted RF emissions	> 150 kHz to 1 GHz	dBm	-57 (2 nW)	-36 dBm for harmonics, -46 dBm for non-harmonic spurious	B = 10 kHz (notes 1 and 2)
Spurious conducted RF emissions	> 1 GHz to 4 GHz	dBm	-47 (20 nW)	-30 dBm for harmonics -40 dBm for non-harmonic spurious	B = 10 kHz
NOTE 1: For transmitters with an RF output above 50 W a limit of -80 dBc will be applied for harmonically related spurious.					
NOTE 2: An exclusion band of ± 1 MHz about the carrier shall be used in active transmit mode.					

6.2.8 Adjacent channel power

First adjacent channel power:

- The RF power measured over the 25 kHz channel bandwidth of the first adjacent channel shall not exceed 2 dBm.
- The RF power measured over a 16 kHz channel bandwidth centred on the first adjacent channel shall not exceed -18 dBm.

Second adjacent channel power:

- The RF power measured over the 25 kHz channel bandwidth of the second adjacent channel shall not exceed -28 dBm.

Fourth adjacent channel power:

- The RF power measured over a 25 kHz channel bandwidth centred on the fourth adjacent channel shall not exceed -38 dBm.

6.2.9 Wide-band noise

The RF power measured in a 25 kHz channel bandwidth shall reduce at a minimum rate of 5 dB per octave from the fourth adjacent channel to a maximum value of minus 53 dBm.

6.2.10 Frequency Tolerance

The frequency of the RF carrier shall be within plus or minus 2 ppm of the selected frequency.

NOTE: 2 ppm = 0,0002 %.

6.2.11 Load VSWR capability

When a 2:1 mismatch is applied to the transmitter output terminals by a length of feeder, which is varied in electrical length by up to half a wavelength, the requirements of clauses 6.2.8 and 6.2.9 shall be met. In addition, the power output shall not be less than minus 3 dB of the manufacturer's declared value (see clause 6.2.4).

6.2.12 Cabinet radiation

The transmitter shall meet the cabinet radiation requirements of ETSI EN 300 113-1 [5].

6.3 Transceiver requirements

6.3.1 Start of transmission

The transmission of the first bit of data shall start 2 083,3 microseconds plus or minus 0,6 microseconds after the nominal start of transmission, measured at the equipment.

NOTE: The nominal start of transmission always coincides with the time of the start of a slot.

6.3.2 Automatic transmitter shutdown

A VDL Mode 4 station shall automatically shut-down power to any final stage amplifier in the event that output power from that amplifier exceeds -30 dBm for more than 250 milliseconds. Reset to an operational mode for the affected amplifier shall require a manual operation.

6.3.3 Receiver to transmitter turnaround time

A station shall be capable of beginning the transmission of the transmitter power stabilization sequence within 16 microseconds after terminating the receiver function.

NOTE: A station receiving in slot N should be capable of transmitting in the following slot (N+1).

6.3.4 Transmitter to receiver turnaround time

A station shall be capable of receiving and demodulating with nominal performance an incoming signal within 1 ms after completing a transmission.

NOTE: A station transmitting in slot N should be capable of receiving in the following slot (N+1).

6.3.5 System timing requirements

A VDL mode 4 station which is unable to maintain either primary or secondary time, shall not transmit.

7 General design requirements

7.1 Controls and indicators

The equipment shall have a visual indication that the device is switched on.

7.2 Class of emission and modulation characteristics

The equipment shall use GFSK modulation. The equipment shall be designed to operate satisfactorily with a channel separation of 25 kHz.

7.3 Warm up

After being switched on, the equipment shall be operational within 5 s, and shall meet the requirements of the present document within one minute under normal conditions.

NOTE: For testing purposes, a primary time source should be available.

8 Test conditions, power sources and ambient temperatures

8.1 Test power source

During testing, the equipment shall be supplied from a test power source capable of producing normal and extreme test voltages as specified in clauses 8.4.1.2 and 8.4.2.3.

The internal impedance of the test power source shall be low enough for its effect on the test results to be negligible. For the purpose of testing the power source voltage shall be measured at the input terminals of the equipment.

During testing, the power source voltages shall be maintained within a tolerance of plus or minus 3 % relative to the voltage level at the beginning of each test.

8.2 Test channels

Tests shall be carried out on at least three channels:

- 136,975 MHz.
- 112,000 MHz.
- 127,500 MHz.

8.3 General conditions of measurement

8.3.1 Receiver test signal arrangement

Test signal sources shall be connected to the receiver input in such a way that the impedance presented to the receiver input is 50 Ω plus or minus 2 Ω , irrespective of whether one or more test signals are applied to the receiver simultaneously.

8.3.2 Performance check

Whilst the equipment is being subjected to the normal or extreme test conditions, establish compliance with the requirements of the following clauses:

- 6.1.4 Sensitivity (Rx).
- 6.2.4 Manufacturer's declared output power (Tx).

- 6.2.10 Frequency Tolerance (Tx).

8.4 Normal and extreme test conditions

Measurements shall be made under normal test conditions and also, where stated, under extreme test conditions.

8.4.1 Normal test conditions

8.4.1.1 Normal temperature and humidity

The normal temperature and humidity conditions for tests shall be a combination of temperature and humidity within the following ranges:

- temperature: +15 °C to +35 °C;
- relative humidity: 20 % to 75 %.

When it is impracticable to carry out the tests under these conditions, a note to this effect, stating the ambient temperature and relative humidity during the tests, shall be added to the test report.

8.4.1.2 Normal power sources

8.4.1.2.1 Mains voltage and frequency

The normal test voltage for equipment to be connected to the mains shall be the nominal mains voltage.

For the purpose of the present document, the nominal voltage shall be the declared voltage or any of the declared voltages for which the equipment was designed.

The frequency of the test power source shall be the nominal ranges declared by the manufacturer.

8.4.1.2.2 Other power sources

For operation from other power sources, the normal test voltage shall be that declared by the equipment manufacturer.

8.4.2 Extreme test conditions

8.4.2.1 Extreme temperatures

For tests at extreme temperatures, measurements shall be made at a lower temperature of minus 10 °C and at an upper temperature of +55 °C. This test shall be performed at the nominal supply voltage as defined in clause 8.4.1.2.1.

8.4.2.2 Procedure for tests at extreme temperatures

8.4.2.2.1 General

The equipment shall be switched off during the temperature stabilizing periods.

For tests at the upper temperature on equipment designed for continuous operation, the equipment shall be placed in the test chamber and left until thermal equilibrium is reached. The equipment shall then be switched on for 30 minutes before measurements are made. Transmitters shall be operated in the highest rated power transmit condition in that 30 minutes period before measurements are made.

For tests at the lower temperature, the equipment shall be left in the test chamber until thermal equilibrium is reached. The equipment shall then be switched on for 1 minute in the standby or receive condition before measurements are made.

8.4.2.2.2 High temperature

- Place the equipment in a chamber and heat to 55 °C (± 3 °C) and allow to stabilize for 1 hour.
- Switch on the equipment (transmitters shall be keyed).

- After 30 minutes carry out a performance check as detailed in clause 8.3.2.
- Switch off the equipment and allow the chamber to cool to room temperature over a one hour period.
- Allow time for the equipment to stabilize to normal room temperature and humidity before carrying out the next test.

8.4.2.2.3 Low temperature

- Place the equipment in a chamber and cool to minus 10 °C (plus or minus 3 °C) for 2 hours.
- Switch on the equipment and maintain the chamber operating temperature at minus 10°C (plus or minus 3 °C).
- After 1 minute carry out a performance check as detailed in clause 8.3.2.
- Switch off the equipment and allow the chamber to rise to room temperature over a 1 hour period.
- Allow time for the equipment to stabilize to normal room temperature and for moisture to disperse before carrying out the next test.

8.4.2.3 Extreme values of test power sources

8.4.2.3.1 Mains voltage and frequency

The extreme test voltages shall be plus or minus 10 % of the manufacturers' declared voltages.

The frequency of the test voltage shall be the nominal frequency declared by the manufacturer.

9 Detailed Test Procedures for the physical layer

The following test procedures are considered to be satisfactory means of establishing compliance with the requirements of the present document. However, alternative test procedures, which provide equivalent information, may be used.

NOTE: Instead of BER tests as outlined below, MER tests might be used. The Message Error Rate (MER) is defined as the total number of messages lost by the VDL receiver plus those messages which do not pass the Cyclic Redundancy Check (CRC), divided by the total number of messages sent. When using MER test procedures, single slot transmissions should be applied with a 2 % MER, which is equivalent to a BER of 1 in 10 000. The percentage

$$\text{MER} = 100 \times [1 - (\text{probability of message success})] = 100 \times [1 - (1 - \text{BER}) (\text{number of bits in message})].$$

9.1 Receiver

9.1.1 BER test

A BER test shall involve a VHF signal generator representing the desired source signal and an external BER test fixture (e.g. a computer and test software or Arbitrary Waveform Generator (AWG) interfaced to a VHF signal generator in vector modulation mode), which receives each burst payload from the receiver under test.

BER mode

A method for placing the receiver into the BER mode shall be provided by manufacturers. The BER mode is distinct from the operational mode.

The BER mode is used to measure the BER requirement (see clause 6.1.2).

- 1) The receiver shall forward each burst payload to the external BER test fixture without error detection or correction procedures.
- 2) The test payload shall be forwarded to the external BER test fixture only if the burst was successfully detected via the standard 24 bit synchronization sequence.

VHF signal generators

Receiver test procedures require the use of a high performance VHF signal generator in order to permit high precision measurement. This VHF signal generator shall be capable of the specified modulation format and transmission waveform.

- 1) The VHF signal generator shall support transmission of VDL test bursts consisting of the ramp-up period plus the standard 24 bit synchronization sequence followed by a variable length test message, up to the maximum length of 19 200 bits.
- 2) An external interface to the VHF signal generator shall be provided in order that the test payload can be provided via an external BER test fixture.

External BER test fixture

- 1) The test payload provided by the external BER test fixture shall be mapped directly into the burst payload in VDL Mode 4 format.
- 2) Unless otherwise stated, tests shall be conducted with maximum length VDL Mode 4 messages.
- 3) The external BER test fixture generating the test payload for transmission by the VHF signal generator, and receiving/processing the received test payload shall be synchronized either explicitly (via a direct connection) or implicitly (by knowledge of the test payload).
- 4) Calculation of cumulative BER statistics shall begin once synchronization of the external BER test fixture between the transmitting and receiving burst payload has been accomplished. The receiving external BER test fixture shall detect the loss of an entire burst implicitly by lack of a burst payload message in the given burst period. Each test should include a running count of synchronization failures in addition to the cumulative BER.

Interfering (or undesired) source

Tests for CCI and ACR with the VDL waveform as the interfering signal shall be performed with the interfering signal applied in a continuous (non-pulsed) manner. The signal generator will be required to simulate the following interfering sources:

- a) VDL Mode 4 waveform (GFSK, symbol rate 19,200 Hz, 1 bit per symbol, frequency deviation 2 400 Hz, Gaussian filter, modulation index = 0,25 plus or minus 0,03 and BT = 0,28 plus or minus 0,03).
- b) VDL Mode 2 waveform (narrow band FM, maximum deviation of plus/minus 5,25 kHz, 400 Hz sine wave modulation).
- c) Unmodulated.
- d) DSB-AM waveform (1 kHz modulated signal with 30 % modulation depth).

The signal generator used to produce interfering signals shall be at least 10 dB to 15 dB better in performance than the equipment under test.

Figure 9.1 shows the basic test set up for receiver BER tests.

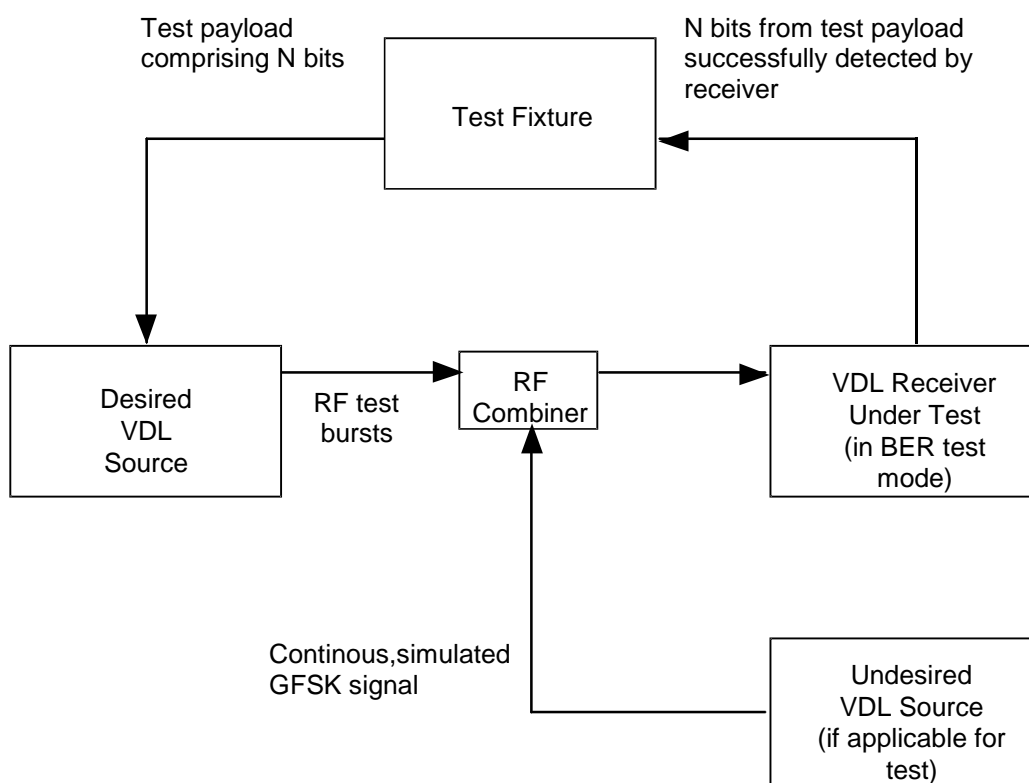

Figure 9.1: Receiver BER measurement

9.1.2 Sensitivity

Equipment Required

- VHF Signal Generator.
- External BER test fixture.

Measurement Procedure

- Step 1: Connect the equipment as shown in figure 9.1 but notice that the RF combiner is not required for this test. Set the receiver under test to the BER mode.
- Step 2: Set the Desired VDL Source, (a VHF signal generator) to generate an input signal to the receiver at one of the test frequencies (see clause 8.2).
- Step 3: Modulate the Desired signal with the test payload (maximum burst length) provided by the external BER test fixture. Adjust the level of the signal generator to the maximum signal level (see clause 6.1.4) at the receiver input terminals.
- Step 4: Repeat Steps 2 and 3 at the two remaining test channels.
- Step 5: Using the external BER test fixture, determine the BER of the demodulated data at the receiver output. Check the Sensitivity requirement (see clause 6.1.4) is achieved at all of the test frequencies (see clause 8.2).

9.1.3 Adjacent Channel Rejection (ACR)

Equipment Required

- 2 VHF Signal Generators.
- External BER test fixture.
- RF combiner.

NOTE: The noise sidebands of the interfering signal should not interfere with the desired signal in the receiver pass band. The isolation offered by the RF combiner should be sufficient to prevent intermodulation between the VHF generators.

Measurement Procedure

- Step 1: Connect the equipment as shown in figure 9.1 and set the receiver to the BER mode.
- Step 2: Adjust the Desired VDL Source (generator A), to produce an input signal to the receiver at one of the test frequencies (see clause 8.2).
- Step 3: Modulate generator A with the test payload (maximum burst length of symbols) provided by the external BER test fixture. Adjust signal generator A to produce the reference signal level (see clause 6.1.3) at the receiver input terminals.
- Step 4: Use the second VHF signal generator (named B), to generate an adjacent channel interfering input signal to the receiver.
- Step 5: Tune generator B to the first upper adjacent channel frequency. Set generator B to produce a VDL Mode 2 or VDL Mode 4 or DSB-AM interfering signal (see clause 9.1.1 - the test should be repeated for each of these three interfering waveforms). Apply the desired input signal and the adjacent interfering signal to the receiver input via the RF combiner.
- Step 6: Adjust the level of signal generator B until the BER is reduced to the minimum requirement (see clause 6.1.2). Record the interfering signal level at the receiver input terminals.
- Step 7: Repeat Steps 5 and 6 for the lower adjacent channel.
- Step 8: Determine the ratio between the interfering and desired signal levels for both upper and lower adjacent channels. Record these two ratios.
- Step 9: Repeat Steps 4 to 8 at the two remaining test channels (see clause 8.2).
- Step 10: Check that the ACR requirement defined in clause 6.1.5 is achieved in all cases.

9.1.4 Rejection of signals within the VHF Aeronautical band

Equipment Required

- 2 VHF Signal Generators.
- External BER test fixture.
- RF combiner.

NOTE: The noise sidebands of the interfering signal should not interfere with the desired signal in the receiver pass band. The isolation offered by the RF combiner should be sufficient to prevent intermodulation between the VHF generators.

Measurement Procedure

- Step 1: Connect the equipment as shown in figure 9.1 and set the receiver to the BER mode.
- Step 2: Adjust the Desired VDL Source, generator A, to produce an input signal to the receiver at one of the test frequencies (clause 8.2).
- Step 3: Modulate generator A with the test payload (maximum burst length of symbols) using the external BER test equipment. Adjust signal generator A to provide the reference signal level (see clause 6.1.3) at the receiver input terminals.
- Step 4: Set the second signal generator (named B), to produce an unmodulated (cw) interfering signal to the receiver input.
- Step 5: Tune generator B to the upper second adjacent channel and adjust the signal generator to the level defined in clause 6.1.6 a).

- Step 6: Apply the wanted input signal and the unmodulated interfering signal to the receiver input via the RF combiner and determine the BER of the demodulated data with the external BER test equipment.
- Step 7: Repeat Steps 5 and 6 for the lower second adjacent channel and the upper and lower third adjacent channels.
- Step 8: Tune generator B to the upper fourth adjacent channel and adjust the signal generator to the level stated in clause 6.1.6 b).
- Step 9: Apply the wanted input signal and the unmodulated interfering signal to the receiver input via the RF combiner and determine the BER of the demodulated data with the external BER test equipment.
- Step 10: Repeat Steps 8 and 9 for the lower fourth adjacent channel.
- Step 11: Tune generator B to +1 MHz from the nominal receiver frequency and adjust the signal generator to the level stated in clause 6.1.6 c).
- Step 12: Apply the wanted input signal and the unmodulated interfering signal to the receiver input via the RF combiner and determine the BER of the demodulated data with the external BER test equipment.
- Step 13: Repeat Steps 11 and 12 for -1 MHz from the nominal receiver frequency.
- Step 14: Set the second signal generator (named B), to produce an unmodulated (cw) interfering signal to the receiver input.
- Step 15: Repeat Steps 5 to 14 at the other test frequencies (see clause 8.2).

9.1.5 Rejection of signals outside the VHF Aeronautical band

Equipment Required

- 2 VHF Signal Generators.
- External BER test fixture.
- RF combiner.

Measurement Procedure

- Step 1: Connect the equipment as shown in figure 9.1 and set the receiver to the BER mode.
- Step 2: Use the Desired VDL Source (generator A), to produce an input signal to the receiver at one of the test frequencies (see clause 8.2).
- Step 3: Modulate generator A with the test payload (maximum burst length of symbols) using the external BER test fixture. Adjust signal generator A to provide the reference signal level (see clause 6.1.3) at the receiver input terminals.
- Step 4: Use the second signal generator (named B), to generate one of the specified interfering signals at the receiver input.
- Step 5: Tune generator B to any frequency defined in clause 6.1.7. Adjust the level of generator B to provide the interfering signal level also defined in clause 6.1.7 at the receiver input terminals.
- Step 6: Apply the desired input signal and the interfering signal to the receiver input via the RF combiner and determine the BER with the external BER test fixture.
- Step 7: Repeat Steps 5 and 6 at the other test frequencies (see clause 8.2).
- Step 8: Check that the BER requirement (see clause 6.1.2) is achieved in all cases.

NOTE 1: The noise sidebands of the interfering signal should not interfere with the desired signal in the receiver pass band. The isolation offered by the RF combiner should be sufficient to prevent intermodulation between the VHF generators.

NOTE 2: Any interfering signal found to reduce the BER below the minimum requirement should be investigated using a spectrum analyser connected to the combiner output. This should determine whether the RF combiner/test setup is producing an on-channel signal into the receiver under test.

NOTE 3: Alternative procedures or theoretical calculation may be used to reduce the number of discrete frequencies which need to be tested.

9.1.6 Desired Signal dynamic range

Equipment Required

- VHF Signal Generator.
- External BER test fixture.

Measurement Procedure

- Step 1: Connect the equipment as shown in figure 9.1 but notice that the RF combiner is not needed for this test. Set the receiver to the BER mode.
- Step 2: Adjust the Desired VDL Source (generator A) to generate an input signal, to the receiver, at one of the test frequencies (see clause 8.2).
- Step 3: Modulate generator A with the test payload (maximum burst length of symbols) using the external BER test fixture. Adjust generator A to provide the maximum reference signal level (see clause 6.1.8) at the receiver input terminals.
- Step 4: Apply the modulated signal to the receiver and determine the BER of the demodulated data at the receiver output with the external BER test fixture.
- Step 5: Repeat Steps 2 to 4 at the two remaining test channels.
- Step 6: Check that the BER requirement (see clause 6.1.2) is achieved in all cases.

9.1.7 Symbol rate capture range

Equipment Required

- VHF Signal Generator.
- External BER test fixture.

Measurement Procedure

- Step 1: Connect the equipment as shown in figure 9.1 but notice that the RF combiner is not needed for this test. Set the receiver to the BER mode.
- Step 2: Tune the Desired VDL Source (generator A) to generate an input signal to the receiver at one of the test frequencies (clause 8.2). Adjust generator A to provide the reference signal level (clause 6.1.3) at the receiver input terminals.
- Step 3: Tune the VHF signal generator to the receiver channel frequency and modulate it with the test payload (maximum burst length of symbols) provided by the external BER test fixture.
- Step 4: Adjust the transmitted data clock offset of the external BER test fixture to the maximum offset specified in clause 6.1.9.
- Step 5: Apply the modulated signal to the receiver and determine the BER of the demodulated data at the receiver output with the external BER test fixture.
- Step 6: Repeat Steps 4 and 5 after adjusting the transmitted data clock offset to the minimum offset specified in clause 6.1.9.

Step 7: Check that the BER requirement (clause 6.1.2) is achieved in all cases.

9.1.8 Frequency capture range

Equipment Required

- VHF Signal Generator.
- External BER test fixture.

Measurement Procedure

- Step 1: Connect the equipment as shown in figure 9.1 but notice that the RF combiner is not needed for this test. Set the receiver to the BER mode.
- Step 2: Set the Desired VDL Source (generator A) and the external BER test fixture to generate a receiver input signal.
- Step 3: Tune generator A to one of the test frequencies (clause 8.2) plus the frequency offset defined in clause 6.1.10 and modulate it with the test payload (maximum burst length of symbols) provided by the external BER test fixture. Adjust generator A to provide the reference signal level (clause 6.1.3) at the receiver input terminals.
- Step 4: Apply the modulated signal to the receiver and determine the BER of the demodulated data at the receiver output with the external BER test fixture.
- Step 5: Repeat Steps 3 and 4 for the negative frequency offset (clause 6.1.10).
- Step 6: Check that the BER requirement (clause 6.1.2) is achieved in all cases.

9.1.9 Co-channel interference

Equipment Required

- 2 VHF Signal Generators.
- External BER test fixture.
- RF combiner.

Measurement Procedure

- Step 1: Connect the equipment as shown in figure 9.1 and set the receiver to the BER mode.
- Step 2: Use the Desired VDL Source (named A), to generate a desired input signal to the receiver.
- Step 3: Tune the generator A to one of the test frequencies (clause 8.2) and modulate the carrier with the test payload (maximum burst length of symbols) provided by the external BER test fixture. Adjust generator A to provide the reference signal level (clause 6.1.3) at the receiver input terminals.
- Step 4: Use the second signal generator (named B), to generate a co-channel interfering input signal to the receiver.
- Step 5: Tune the signal generator B to the receiver channel frequency and configure it to produce VDL Mode 4 interfering signal as specified in clause 6.1.11, with signal level 12 dB below the reference signal level (clause 6.1.3) at the receiver input terminals.
- Step 6: Apply the desired signal and the co-channel interfering FM modulated signal to the receiver input via the RF combiner and measure the BER of the demodulated data at the receiver output with the external BER test fixture.
- Step 7: Repeat Steps 2 to 6 at the two remaining test channels (clause 8.2).
- Step 8: Check that the BER requirement (clause 6.1.2) is achieved in all cases.

9.1.10 Conducted spurious emission

Equipment Required

- Resistive load equal to the nominal input impedance of the receiver.
- Calibrated spectrum analyser to cover the frequency range defined in clause 6.1.12.

Measurement Procedure

- Step 1: Connect the RF output of the equipment under test directly into the RF input of the spectrum analyser. Exercise caution, do not allow the transmitter to radiate.
- Step 2: Tune the ground station to one of the test frequencies (clause 8.2).
- Step 3: Using the calibrated spectrum analyser, measure the power level of any spurious emissions across the matching resistive load at the input of the receiver over the frequency range defined in clause 6.1.12.
- Step 4: Record the frequency and power level of all signals which exceed the limit specified in clause 6.1.12.
- Step 5: Repeat Steps 2 to 4 at the two remaining test channels (clause 8.2).
- Step 6: Check that the requirements of clause 6.1.12 are achieved in all cases.

9.1.11 In-band Intermodulation

Equipment Required

- 3 VHF Signal Generator.
- External BER test fixture.
- RF combiner.

Measurement Procedure

- Step 1: Connect the equipment as shown in figure 9.2.
- Step 2: Use a signal generator (named A), to generate the desired input signal to the receiver.
- Step 3: Tune generator A to one of the test frequencies (clause 8.2) and modulate the carrier with the test payload (maximum burst length of symbols) provided by the external BER test fixture. Adjust generator A to provide a level of minus 75 dBm at the receiver input terminals.
- Step 4: Tune interfering signal generator B to a frequency 1 MHz above the selected test frequency. Set signal generator B to produce an unmodulated carrier, input to the receiver input terminals at a level of minus 32 dBm.
- Step 5: Tune interfering signal generator C to a frequency 2 MHz above the selected test frequency. Set signal generator C to produce a simulated Mode 4 signal, input to the receiver input terminals at a level of minus 32 dBm.
- Step 6: Apply the desired signal and the two interfering signals to the receiver input via the RF combiner and determine the BER of the demodulated data at the receiver output with the external BER test fixture.
- Step 7: Repeat Steps 3 to 6 for the remaining frequency combinations by retuning generators B and C.
- Step 8: Check that the BER requirement (clause 6.1.2) is achieved in all cases.

NOTE: In the absence of the desired signal (i.e. Generator A switched "off"), the intermodulation products produced by any interaction between the interfering signal generators B and C, should be less than minus 105 dBm at the receiver input. Additional band-pass filters, inserted between each generator and the RF combiner, may be necessary to reduce the intermodulation product.

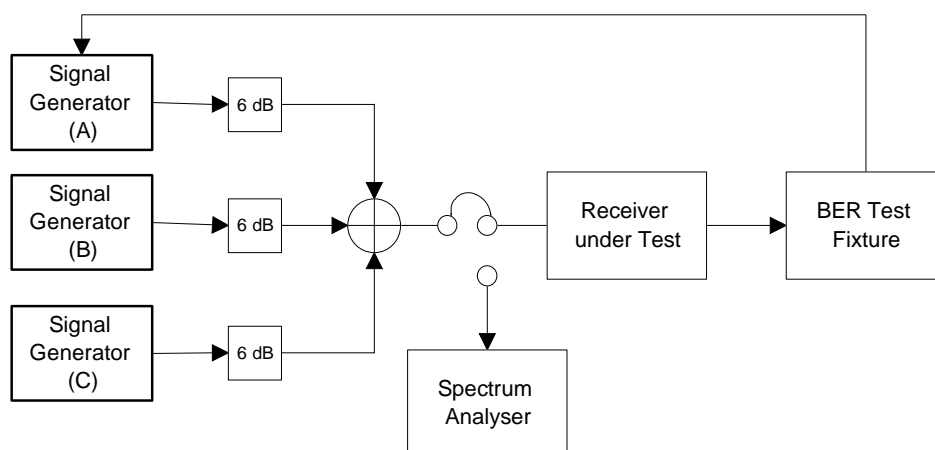

Figure 9.2: Intermodulation measurement

9.2 Transmitter

9.2.1 Channel Bit Rate

This requirement may be satisfied by written evidence.

The manufacturer shall declare crystal stability, aging and temperature coefficients.

The evidence shall demonstrate that consideration has been given to the temperature variation to which the equipment will be subjected and the frequency range for which the equipment is designed to operate.

9.2.2 Manufacturer's declared output power

Equipment Required

- Transmission generator, PC with suitable software.
- Attenuator 30 dB, 30 W.
- Power meter, with pulse power measurement facility or vector signal analyser.

Measurement Procedure

- Step 1: Connect the equipment as shown in figure 9.3.
- Step 2: Tune the transmitter to one of the test frequencies (clause 8.2).
- Step 3: Key the transmitter under test "on" and modulate the carrier with continuous maximum length VDL Mode 4 messages from the transmission generator.
- Step 4: Set the power meter (or vector signal analyser) to capture the VDL Mode 4 transmitted signal and determine the transmitter output power during the message period.
- Step 5: Repeat Steps 2 to 4 at the two remaining test channels.
- Step 6: Check that the measured output power is consistent with the manufacturer's declared output power according to clause 6.2.4, and remains so at all three test channels.

NOTE: Output power delivered into a 50 Ω load should be measured during signal transmission and should not be averaged over the time intervals between signal transmissions.

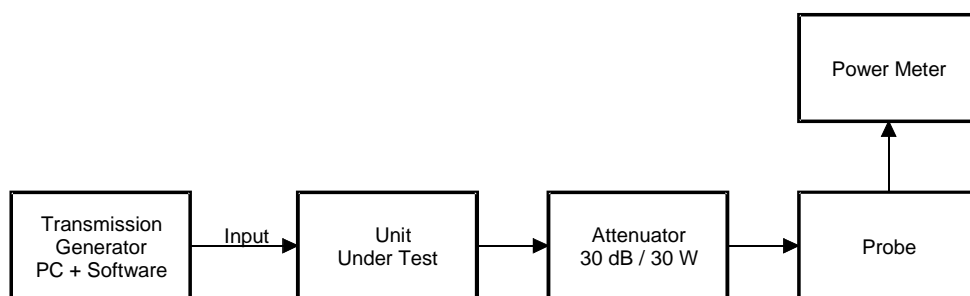

Figure 9.3: Output power measurement

9.2.3 RF power rise time

Equipment Required

- Transmission Generator, PC with suitable software.
- Attenuator 30 dB, 30 W.
- Vector signal analyser.

Measurement Procedure

- Step 1: Connect the equipment as shown in figure 9.4.
- Step 2: Configure the vector analyser to display both constellation diagram and power versus time charts.
- Step 3: Use the transmission generator to produce a Mode 4 message and capture the start of this message.
- Step 4: Using both constellation and power versus time display identify the first symbol of the synchronization sequence.
- Step 5: Record RF power level at the first synchronization symbol defined in clause 5.2.
- Step 6: Check that the RF power rise time defined in clause 6.2.5 is achieved.

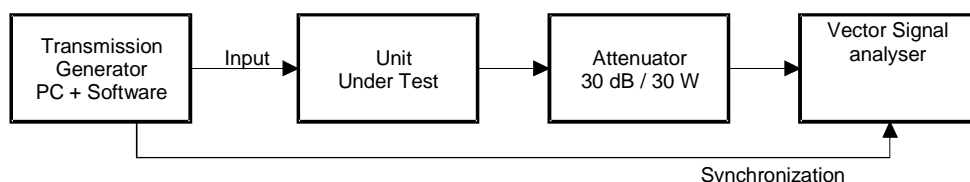

Figure 9.4: RF power rise and release time measurement

9.2.4 RF power release time

Equipment Required

- Transmission Generator, PC with suitable software.
- Attenuator 30 dB, 30 W.
- Vector signal analyser.

Measurement Procedure

- Step 1: Connect the equipment as shown in figure 9.4.
- Step 2: Configure the vector signal analyser in digital demodulation mode, to display log magnitude of I and Q vectors, with normalization disabled. Set the Y axis to read "dBm" The symbol times are displayed on the resultant profile of power versus time. Use of the trigger hold off function will aid signal acquisition.

- Step 3: Using the transmission generator to produce a VDL Mode 4 message. Capture the end of this message on the vector signal analyser.
- Step 4: Use the power versus time display to determine the corresponding profile for each symbol of the "power down" ramp.
- Step 5: Check that the RF power release time defined in clause 6.2.6 is achieved.

9.2.5 Spurious emissions

Equipment Required

- Transmission Generator, PC with suitable software.
- Attenuator 30 dB, 30 W.
- Notch filter or band pass filter, to suppress the on-channel signal by at least 60 dB.
- Spectrum analyser with power band marker function.

Measurement Procedure

- Step 1: Connect the equipment as shown in figure 9.5.
- Step 2: Tune the transmitter to one of the test frequencies.
- Step 3: Use the filter to reject the on-channel signal in order to increase the dynamic range of the measurement without overloading the spectrum analyser.
- Step 4: Set the transmission generator to produce continuous maximum length VDL Mode 4 messages and key the transmitter under test "on".
- Step 5: Adjust the spectrum analyser reference level to provide the maximum dynamic range for display and set the input attenuator to minimum required to ensure that no signal at the analyser input exceeds the maximum allowable level.
- Step 6: Measure the power level at each visible spurious signal using power band markers appropriate to the bandwidths specified in clause 6.2.7.
- Step 7: Measure the frequency response of the filter and take this into account when presenting spurious measurement results. If a band pass filter is used, it will need to be tuned to several measurement frequencies, covering the overall measured frequency range.
- Step 8: Check that the results do not exceed the limits specified in clause 6.2.7.

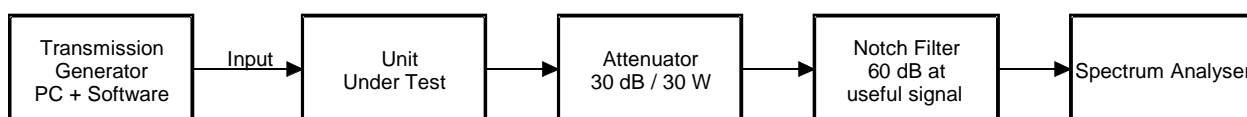

Figure 9.5: Spurious emissions measurement

9.2.6 Adjacent channel power

9.2.6.1 Method of measurement for the first adjacent channel

Equipment Required

- Transmission Generator, PC with suitable software.
- Attenuator 30 dB, 30 W.
- Spectrum analyser with power band marker function.

Measurement Procedure

- Step 1: Connect the equipment as shown in figure 9.6.
- Step 2: Tune the transmitter to one of the test frequencies (clause 8.2).
- Step 3: Key the transmitter under test "on" and modulate it with the transmission generator to produce continuous maximum length VDL Mode 4 messages.
- Step 4: Adjust the attenuator in the analyser to the minimum value which does not overload the input stage of the unit.
- Step 5: Using 100 kHz span, display the VDL Mode 4 signal envelope. Use the analyser IF signal power as the trigger source for the display and set averaging to 10.
- Step 6: Using the power band marker function of the analyser, measure the power in a 16 kHz bandwidth, and then in a 25 kHz bandwidth, of the first upper adjacent channel.
- Step 7: Repeat Steps 3 to 6 for the first lower adjacent channel.
- Step 8: Record the highest of the two measured values. Check that the first adjacent channel power meets the first adjacent channel power requirement defined in clause 6.2.8.
- Step 9: Repeat Steps 2 to 8 at the two remaining test frequencies (clause 8.2).

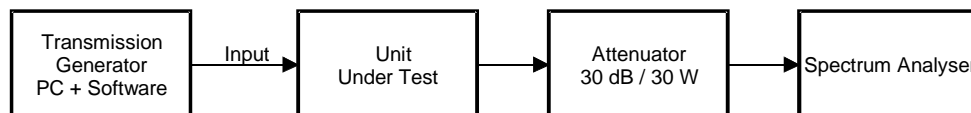

Figure 9.6: First adjacent channel power measurement

9.2.6.2 Method of measurement for the second adjacent channel

Equipment Required

- Transmission Generator, PC with suitable software.
- Attenuator 30 dB, 30 W.
- VHF crystal filter with a 3 dB bandwidth of 25 kHz and, with attenuation in excess of 50 dB at ± 50 kHz.
- Spectrum analyser with power band marker function.

Measurement Procedure

NOTE: To protect the analyser and the crystal filter, ensure that the transmitter cannot be keyed "on", at the frequency of the crystal filter used for this test.

- Step 1: Connect the equipment as shown in figure 9.7.
- Step 2: Tune the transmitter to one of the test frequencies (clause 8.2).
- Step 3: Offset the tuned frequency of the transmitter under test to 50 kHz above the VHF crystal filter centre frequency. Key the transmitter under test "on". Use the transmission generator to produce continuous maximum length VDL Mode 4 messages.
- Step 4: Set the analyser span to 50 kHz and centre frequency to the centre frequency of the VHF crystal filter. Decrease the analyser input attenuator to the minimum level at which the attenuated RF signal from the transmitter under test does not overload the analyser. Use the analyser IF signal power as the trigger source for the display and set averaging to 10.
- Step 5: Set the analyser's power band marker function to 40 kHz. Notice that the measurement bandwidth is defined by the VHF crystal filter and setting the power band marker to the same bandwidth will give an erroneous result.
- Step 6: Determine the second lower adjacent channel power.

- Step 7: Repeat Steps 2 to 5 with the transmitter under test tuned to 50 kHz below the crystal filter. Determine the second upper adjacent channel power.
- Step 8: Record the second adjacent channel power as the highest of the two measured values.
- Step 9: Check that the second adjacent channel power is less than the second adjacent channel power requirement defined in clause 6.2.8.
- Step 10: Repeat Steps 2 to 9 at the two remaining test frequencies (clause 8.2).

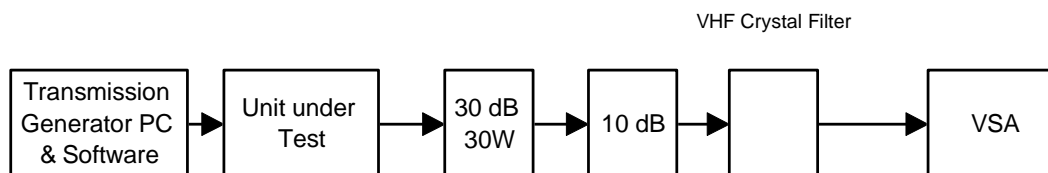

Figure 9.7: Second and fourth adjacent channel power measurement

9.2.6.3 Method of measurement for the fourth adjacent channel

Equipment Required

- Transmission Generator, PC with suitable software.
- Attenuator 30 dB, 30 W.
- VHF crystal filter with a 3 dB bandwidth of 25 kHz and, with attenuation in excess of 50 dB at plus or minus 50 kHz.
- Spectrum analyser with power band marker function.

Measurement Procedure

- Step 1: Connect the equipment as shown in figure 9.7.
- Step 2: Tune the transmitter to one of the test frequencies (clause 8.2).
- Step 3: Offset the tuned frequency of the transmitter under test to 100 kHz above the VHF crystal filter centre frequency. Key the transmitter under test "on". Use the transmission generator to produce continuous maximum length VDL Mode 4 messages.
- Step 4: Set the analyser span to 50 kHz and centre frequency to the centre frequency of the VHF crystal filter. Decrease the analyser input attenuator to the minimum level at which the attenuated RF signal from the transmitter under test does not overload the analyser. Use the analyser IF signal power as the trigger source for the display and set averaging to 10.
- Step 5: Set the analyser's power band marker function to 40 kHz. Notice that the measurement bandwidth is defined by the VHF crystal filter and setting the power band marker to the same bandwidth will give an erroneous result.
- Step 6: Determine the fourth lower adjacent channel power.
- Step 7: Repeat Steps 2 to 5 with the transmitter under test tuned to 100 kHz below the crystal filter. Determine the fourth upper adjacent channel power.
- Step 8: Record the fourth adjacent channel power as the highest of the two measured values.
- Step 9: Check that the fourth adjacent channel power is less than the fourth adjacent channel power requirement defined in clause 6.2.8.
- Step 10: Repeat Steps 2 to 9 at the two remaining test frequencies (clause 8.2).

9.2.6.4 Alternative measurement procedure for Adjacent Channel Power (ACP)

- Step 1: Connect the equipment as shown in figure 9.7.
- Step 2: Tune the transmitter to one of the test frequencies.
- Step 3: Start the transmission generator that produces transmit blocks and simulates the transmit/receive duty cycle.
- Step 4: Use an attenuator to protect the measurement equipment, and a notch filter centred on the carrier frequency if the dynamic range of the spectrum analyser is not sufficient. Set the spectrum analyser resolution bandwidth (Br) much narrower than the channel bandwidth, and the video bandwidth (Bv) equal to ten times Br in order to avoid errors due to video averaging of noise.
- Step 5: Measure and store the RF signal spectrum centred on the carrier frequency with a frequency span wide enough to display all the modulation spectrum between the minus 80 dB points, referred to the peak value.
- Step 6: Convert the logarithmic trace values from the spectrum analyser to linear spectral power densities by the relation:

$$P_i = \frac{10^{\frac{P_{idBm}}{10}}}{B_n}$$

where P_{idBm} = Trace values (dBm)

B_n = Effective noise bandwidth of the spectrum analyser (Hz)

P_i = Spectral power densities (mW/Hz)

NOTE: $B_n = k \times B_r$, where k is a constant specified for each spectrum analyser.

- Step 7: Perform an integration of the linear spectral power densities. For computation of the linear spectral power values in the first, second and fourth adjacent channels, use the formula:

$$P_{ch} = B_{ch} \times \frac{1}{N} \times \sum_{i=1}^N P_i$$

where P_{ch} = power in the considered channel

B_{ch} = assigned bandwidth of the first, second or third adjacent channel

N = Number of power samples within the limits of the assigned bandwidth, B_{ch}

- Step 8: Perform the adjacent channel measurement for the first, second and fourth adjacent channels on both sides of the carrier frequency (lower and upper adjacent channels).
- Step 9: Check that the adjacent channel power on either side of the carrier for the first, second and fourth adjacent channels are lower than the respective adjacent channel power requirements defined in clause 6.2.8.
- Step 10: Repeat Steps 2 to 9 at the two remaining test frequencies.

9.2.7 Wide-band noise

Equipment Required

- Transmission Generator, PC with suitable software.
- Attenuator 30 dB, 30 W.
- Notch filter with a minimum of 30 dB on-channel attenuation.

- Spectrum analyser with power band marker function.

Measurement Procedure

- Step 1: Connect the equipment as shown in figure 9.8.
- Step 2: Tune the transmitter to one of the test frequencies (clause 8.2).
- Step 3: Use the filter to attenuate the carrier in order to increase the dynamic range of the measurement without overloading the spectrum analyser. Measure the frequency response of the filter and take this into account when presenting noise measurement results.
- Step 4: Key the transmitter under test using the transmission generator with repetitive maximum length VDL Mode 4 messages.
- Step 5: Adjust the spectrum analyser reference level to provide the maximum dynamic range for display and set the input attenuator to minimum. Ensure that no signal at the analyser input exceeds the maximum allowable level.
- Step 6: Record the transmitter noise level versus the frequency displacement using the power band marker function of the analyser.
- Step 7: Check that the wide-band noise does not exceed the limit specified in clause 6.2.9.
- Step 8: Repeat Steps 2 to 7 at the two remaining test frequencies (clause 8.2).

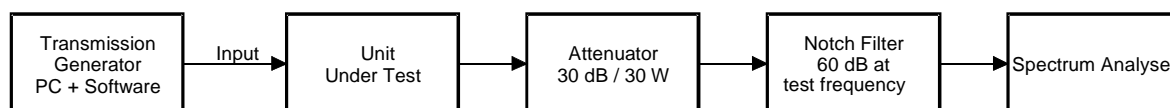

Figure 9.8: Wideband noise measurement

9.2.8 Frequency Error

9.2.8.1 Definition

The frequency error is the difference between the measured carrier frequency and its nominal value.

9.2.8.2 Method of measurement

The carrier frequency shall be measured in the absence of modulation, with the transmitter connected to a coaxial termination. Measurements shall be made under extreme test conditions.

9.2.8.3 Limits

The frequency error shall be within the limits defined in clause 6.2.10.

9.2.9 Load VSWR capability

Equipment Required

- Transmission Generator, PC with suitable software.
- 30 dB directional coupler.
- Adjustable delay line.
- 2:1 VSWR Resistive load.
- Vector signal analyser with power band marker function.

Measurement Procedure

- Step 1: Connect the equipment as shown in figure 9.9.
- Step 2: Tune the transmitter to one of the test frequencies.
- Step 3: Key the transmitter under test with the transmission generator with repetitive maximum length VDL Mode 4 messages.
- Step 4: Vary the VSWR phase angle of the load with the delay line and measure the minimum average forward RF output power from the transmitter using the vector signal analyser power band marker function.
- Step 5: Check that the minimum average forward RF output power is greater than the limit defined in clause 6.2.11.
- Step 6: Repeat Steps 2 to 5 at the two remaining test frequencies.

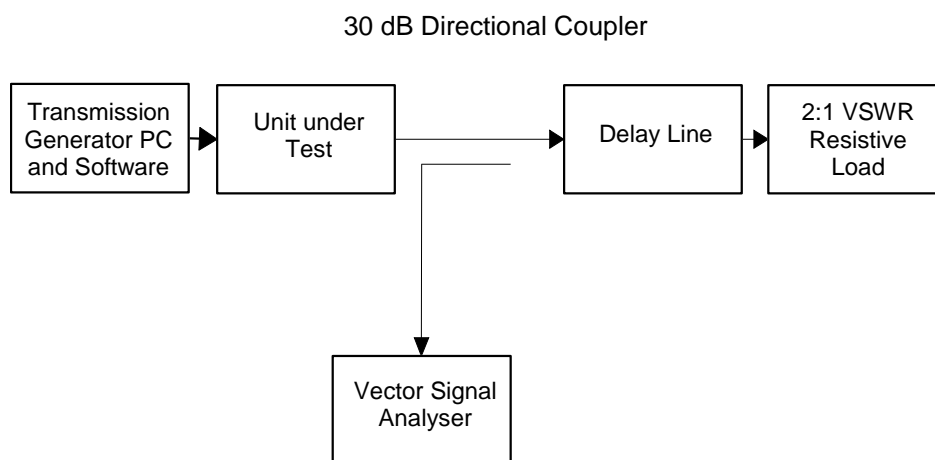

Figure 9.9: Load VSWR capability

9.3 Physical layer, system parameters

9.3.1 Receiver to Transmitter turn-around time

Measurement Procedure

- Step 1: Limit the periodic dither range of the periodic streams from the equipment to plus or minus 2.
- Step 2: Establish a series of periodic streams from the equipment under test.
- Step 3: Use the test equipment to generate a periodic reservation in the slot before each system under test periodic stream.
- Step 4: Ensure that the timing of the bursts from the test equipment results in termination of the bursts 16 microseconds before the nominal slot start time.
- Step 5: Monitor the movement of the streams from the system under test to ensure that the reservations made by the test equipment are respected by the system under test.

NOTE: This shows that the system under test successfully decodes information in the slot before transmitting itself.

9.3.2 Transmitter to Receiver turn-around time

Measurement Procedure

- Step 1: Limit the periodic dither range of the periodic streams from the system under test to plus or minus 2.

- Step 2: Establish a series of periodic streams from the equipment under test.
- Step 3: Use the test equipment to generate a periodic reservation in the slot after each periodic stream from the equipment under test.
- Step 4: Ensure that the timing of the bursts from the test equipment results in the start of the bursts 1 millisecond after completion of the transmission from the equipment under test.
- Step 5: Monitor the movement of the streams from the equipment under test to ensure that the reservations made by the test equipment are respected by the equipment under test.

NOTE 1: This shows that the equipment successfully decodes information in the slot after transmitting itself. Note that ideally the transmissions from the equipment should be longer than the normal sync burst length in order to ensure that the test equipment does not produce signals earlier than the slot boundary. A bespoke message format could be used.

NOTE 2: The test equipment should produce a signal at the reference level and the output of the system under test should be measured to monitor the successful received message rate - this should be shown to be greater than the equivalent of a BER at nominal performance.

9.3.3 Tuning Time

This requirement may be satisfied by written evidence.

Annex A (informative): Cross reference matrix

Table A.1 outlines the mapping between the VDL Mode 4 Ground station requirements and the related test procedures. In these tables:

- column 1 is a reference to the requirement in the present document;
- column 2 identifies clause titles taken from the present document;
- column 3 is a reference to testing requirements specified elsewhere in the present document. Several tests verify a whole group of requirements. They are only mentioned in the first row of such a group, usually a headline. The applicability of these tests to the subordinated requirements is indicated by ditto marks (") in the rows following the first instance of a test case name. Amplification of individual entries is provided by the following notes;
- column 4 qualifies each test procedure to be:
 - Essential: meaning that it is included with the Essential Radio Test Suite and therefore the requirement should be demonstrated to be met in accordance with the referenced procedures;
 - Other: meaning that the test procedure is illustrative but other means of demonstrating compliance with the requirement are permitted;
 - Excluded: meaning that there is no specific test for the requirement.

NOTE 1: The clause number in column 1 is a headline or an introduction to requirements that are detailed in subsequent clauses. No test can be applied.

NOTE 1a: The clause number in column 1 is a definition. No test can be applied.

NOTE 2: The requirement listed in column 1 does not allow definition of a satisfactory go/no go test, for example, because it would be technically infeasible, or economically unreasonable. There are circumstances where the implementer can provide reasoned argument or test evidence that the implementation under test does conform to the requirements in column 1. For each of these circumstances the implementer may be required to satisfy the authorities by separate technical evidence.

NOTE 3: The requirement listed in column 1 is applicable only to VDL Mode 4 airborne equipment. No ground equipment test is required.

NOTE 4: This topic is heavily dependent on the implementation or results from a recommendation. No particular test is therefore provided in the present document.

NOTE 5: All tests whether "E" or "O" are relevant to the requirements. Rows designated "E" collectively make up the Essential Radio Test Suite; those designated "O" make up the Other Test Suite; for those designated "X" there is no test specified corresponding to the requirement. All tests classified "E" should be performed as specified with satisfactory outcomes as a necessary condition for a presumption of conformity. Requirements associated with tests classified "O" or "X" should be complied with as a necessary condition for presumption of conformity, although conformance with the requirement may be claimed by an equivalent test or by manufacturer's assertion supported by appropriate entries in the technical construction file.

Table A.1: VDL Mode 4 requirements according to ICAO TM

Requirement reference	Title	Test Case	E/O/X
6.1	Receiver Requirements	See note 1	X
6.1.1	Receiver operating range	See note 1a	X
6.1.2	BER requirement	9.1.1	E
6.1.3	Reference signal level	See note 2	X
6.1.4	Sensitivity	9.1.2	E
6.1.5	Adjacent channel rejection	9.1.3	E
6.1.6	Rejection of signals within the VHF Aeronautical band	9.1.4	E
6.1.7	Rejection of signals outside the VHF Aeronautical band	9.1.5	E
6.1.8	Desired signal dynamic range	9.1.6	E
6.1.9	Symbol rate capture range	9.1.7	E
6.1.10	Frequency capture range	9.1.8	E
6.1.11	Co-channel interference	9.1.9	E
6.1.12	Conducted spurious emission	9.1.10	E
6.1.13	FM Broadcast Intermodulation	See note 1	X
6.1.13.1	Radio frequencies in the band 112 MHz to 137,0 MHz	9.1.1	E
6.1.14	In-band Intermodulation	9.1.11	E
6.1.15	Cabinet radiation	See note 4	O
6.2	Transmitter requirements	See note 1	X
6.2.1	Transmitter operating range	See note 1a	X
6.2.2	Channel Bit Rate	9.2.1	E
6.2.3	Protection of the transmitter	See note 4	O
6.2.4	Manufacturer's declared output power	9.2.2	E
6.2.5	RF power rise time	9.2.3	E
6.2.6	RF power release time	9.2.4	E
6.2.7	Conducted Spurious emissions	9.2.5	E
6.2.8	Adjacent channel power	9.2.6	E
6.2.9	Wide-band noise	9.2.7	E
6.2.10	Frequency Tolerance	9.2.8	E
6.2.11	Load VSWR capability	9.2.9	E
6.2.12	Cabinet radiation	See note 4	O
6.3	Transceiver requirements	See note 1	X
6.3.1	Start of transmission	See note 4	O
6.3.2	Automatic transmitter shutdown	See note 2	O
6.3.3	Receiver to transmitter turnaround time	9.3.1	E
6.3.4	Transmitter to receiver turnaround time	9.3.2	E
6.3.5	System timing requirements	9.3.3	O
7	General design requirements	See note 1	X
7.1	Controls and indicators	See note 2	O
7.2	Class of emission and modulation characteristics	See note 2	O
7.3	Warm up	See note 2	O

Annex B (informative): Bibliography

ED 92B, October 2012: "Minimum Operational Performance Specification for an Airborne VDL Mode 2 Transceiver Operating in the frequency range 118-136,975 MHz".

History

Document history		
V1.1.1	January 2002	Publication
V1.2.1	April 2005	Publication
V1.3.1	November 2006	Publication
V1.3.2	December 2010	Publication
V1.3.3	July 2011	Publication
V1.3.4	October 2011	Publication
V1.4.0	December 2014	EN Approval Procedure AP 20150404: 2014-12-05 to 2015-04-06
V1.4.1	April 2015	Publication