

ETSI EN 301 841-2 V1.1.1 (2004-03)

European Standard (Telecommunications series)

**Electromagnetic compatibility
and Radio spectrum Matters (ERM);
VHF air-ground Digital Link (VDL) Mode 2;
Technical characteristics and
methods of measurement
for ground-based equipment;
Part 2: Upper layers**



Reference

DEN/ERM-TG25-015-2

Keywords

aeronautical, radio, testing

ETSI

650 Route des Lucioles
F-06921 Sophia Antipolis Cedex - FRANCE

Tel.: +33 4 92 94 42 00 Fax: +33 4 93 65 47 16

Siret N° 348 623 562 00017 - NAF 742 C
Association à but non lucratif enregistrée à la
Sous-Préfecture de Grasse (06) N° 7803/88

Important notice

Individual copies of the present document can be downloaded from:

<http://www.etsi.org>

The present document may be made available in more than one electronic version or in print. In any case of existing or perceived difference in contents between such versions, the reference version is the Portable Document Format (PDF). In case of dispute, the reference shall be the printing on ETSI printers of the PDF version kept on a specific network drive within ETSI Secretariat.

Users of the present document should be aware that the document may be subject to revision or change of status. Information on the current status of this and other ETSI documents is available at

<http://portal.etsi.org/tb/status/status.asp>

If you find errors in the present document, send your comment to:

editor@etsi.org

Copyright Notification

No part may be reproduced except as authorized by written permission.
The copyright and the foregoing restriction extend to reproduction in all media.

© European Telecommunications Standards Institute 2004.
All rights reserved.

DECT™, PLUGTESTS™ and UMTS™ are Trade Marks of ETSI registered for the benefit of its Members.
TIPHON™ and the TIPHON logo are Trade Marks currently being registered by ETSI for the benefit of its Members.
3GPP™ is a Trade Mark of ETSI registered for the benefit of its Members and of the 3GPP Organizational Partners.

Contents

Intellectual Property Rights	10
Foreword.....	10
Introduction	10
1 Scope	11
2 References	11
3 Definitions and abbreviations.....	12
3.1 Definitions	12
3.1.1 Basic reference model definitions.....	12
3.1.2 Service conventions definitions	12
3.1.3 General definitions.....	13
3.2 Abbreviations	13
4 General architecture of VDL Mode 2.....	14
5 Link layer protocols and services functional specifications.....	15
5.1 MAC sublayer specifications	16
5.1.1 MAC services	16
5.1.1.1 Multiple access.....	16
5.1.1.2 Channel congestion	16
5.1.2 MAC service system parameters	17
5.1.2.1 Timer TM1 (inter-access delay timer).....	17
5.1.2.2 Timer TM2 (channel busy timer).....	17
5.1.2.3 Parameter p (persistence)	17
5.1.2.4 Counter M1 (maximum number of access attempts)	17
5.1.3 Description of procedures.....	17
5.1.3.1 Channel sensing	17
5.1.3.2 P-persistent CSMA access times.....	17
5.1.3.3 Inter-access interval	18
5.1.3.4 Channel access procedure	18
5.1.3.4.1 Purpose	18
5.1.3.4.2 Use.....	18
5.1.3.4.3 Procedure.....	18
5.1.3.5 AVLC frame reception.....	18
5.1.3.5.1 Purpose	18
5.1.3.5.2 Use.....	18
5.1.3.5.3 Procedure.....	18
5.2 Data link layer service protocol specifications.....	19
5.2.1 Interface with MAC sub layer.....	19
5.2.1.1 Sequence of primitives.....	19
5.2.2 Data Link State Machines.....	20
5.2.2.1 LME state machine	21
5.2.2.2 DLE top state machine	22
5.2.2.3 DLE data transfer state diagram.....	23
5.2.2.4 DLE selective reject state machines.....	24
5.2.2.4.1 SRM mode Sending SREJ.....	24
5.2.2.4.2 SRM mode Receiving SREJ.....	24
5.2.2.4.3 FRM mode.....	25
5.2.2.5 DLE termination state machine.....	26
5.2.3 Services.....	26
5.2.3.1 Received frame sequencing procedure.....	26
5.2.3.1.1 Purpose	26
5.2.3.1.2 Use.....	26
5.2.3.1.3 Procedure.....	26
5.2.3.2 Error detection procedure.....	26
5.2.3.2.1 Purpose	26

5.2.3.2.2	Use.....	26
5.2.3.2.3	Procedure.....	27
5.2.3.3	Station identification.....	27
5.2.3.4	Broadcast addressing.....	27
5.2.3.5	Data transfer.....	27
5.2.4	Frame format.....	27
5.2.4.1	Address structure.....	27
5.2.4.2	Address fields0.0.3.3.....	27
5.2.4.2.1	Air-ground status bit.....	28
5.2.4.2.2	Command/response status bit.....	28
5.2.4.2.3	Data link service addresses.....	28
5.2.4.2.4	Address type.....	28
5.2.4.2.5	Aircraft specific addresses.....	28
5.2.4.2.6	ICAO-administered ground station specific addresses.....	28
5.2.4.2.7	ICAO-delegated ground station specific addresses.....	28
5.2.4.3	Broadcast address.....	28
5.2.4.3.1	Encoding.....	29
5.2.4.4	Link control field.....	29
5.2.4.5	Information field.....	29
5.2.5	Transmit queues management.....	29
5.2.6	Data link service system parameters.....	30
5.2.6.1	Parameter T1 (delay before non acknowledged retransmission).....	30
5.2.6.2	Parameter T2 (delay before acknowledgment).....	31
5.2.6.3	Parameter T3 (link initialization time).....	31
5.2.6.4	Parameter T4 (maximum delay between transmissions).....	31
5.2.6.4.1	Recommendation.....	31
5.2.6.5	Parameter N1 (maximum number of bits of any frame).....	31
5.2.6.6	Counter N2 (maximum number of transmissions).....	31
5.2.6.7	Parameter k (window size).....	32
5.2.7	DLE retransmission timers.....	32
5.2.8	Description of procedures.....	32
5.2.8.1	Procedure retransmission schedule.....	32
5.2.8.1.1	Purpose.....	32
5.2.8.1.2	Use.....	32
5.2.8.1.3	Procedure.....	32
5.2.8.2	Procedure frame retransmission.....	32
5.2.8.2.1	Purpose.....	32
5.2.8.2.2	Use.....	32
5.2.8.2.3	Procedure.....	33
5.2.8.3	Procedure XID frame retransmission.....	33
5.2.8.3.1	Purpose.....	33
5.2.8.3.2	Use.....	33
5.2.8.3.3	Procedure.....	33
5.2.8.4	Procedure link monitoring.....	33
5.2.8.4.1	Purpose.....	33
5.2.8.4.2	Use.....	33
5.2.8.4.3	Procedure.....	33
5.2.8.5	Procedure link recovery.....	33
5.2.8.5.1	Purpose.....	33
5.2.8.5.2	Use.....	33
5.2.8.5.3	Procedure.....	33
5.2.9	Modes of operation.....	34
5.2.9.1	Operational mode.....	34
5.2.9.2	Non-operational mode.....	34
5.2.9.2.1	DISC frame.....	34
5.2.9.2.2	DM frame.....	34
5.2.9.3	Frame reject mode.....	34
5.2.9.4	Sent selective reject mode.....	34
5.2.10	Use of the P/F bit.....	34
5.2.10.1	General.....	34
5.2.10.2	INFO frames.....	35
5.2.10.3	Recommendation.....	35

5.2.10.4	Unnumbered frames	35
5.2.11	Unnumbered command frame collisions	35
5.2.11.1	DLE procedures	35
5.2.11.2	LME procedures.....	35
5.2.12	XID frame.....	35
5.2.13	Broadcast	35
5.2.14	Information transfer	35
5.2.14.1	Void.....	35
5.2.14.1.1	Eliminate redundant frames.....	35
5.2.14.1.2	Recommendation.....	36
5.2.14.1.3	Recommendation.....	36
5.2.14.1.4	Recommendation.....	36
5.2.14.1.5	Procedures for transmission.....	36
5.2.14.1.6	Recommendation.....	36
5.2.14.1.7	Recommendation.....	36
5.2.14.1.8	Recommendation.....	36
5.2.14.2	SREJ frame	36
5.2.14.3	FRMR frame	37
5.2.14.4	UA frame	37
5.2.14.5	UI frame	37
5.2.14.6	TEST frame.....	37
5.3	VDL management entity	37
5.3.1	Services.....	37
5.3.1.1	Link provision	37
5.3.1.2	Link change notifications.....	37
5.3.2	Exchange identity (XID) parameter	38
5.3.2.1	Encoding	38
5.3.2.2	Public parameters.....	38
5.3.2.2.1	HDLC public parameter set identifier	38
5.3.2.2.2	Timer T1 parameter.....	39
5.3.2.3	VDL private parameters.....	39
5.3.2.4	General purpose information private parameters	39
5.3.2.4.1	VDL private parameter set identifier.....	39
5.3.2.4.2	Connection management parameter	39
5.3.2.4.3	Signal Quality Parameter (SQP).....	40
5.3.2.4.4	XID sequencing parameter	41
5.3.2.4.5	AVLC specific options parameter	41
5.3.2.4.6	Expedited subnetwork connection parameter	42
5.3.2.4.7	LCR cause parameter	42
5.3.2.5	Aircraft-initiated information private parameters	43
5.3.2.5.1	Modulation support parameter.....	43
5.3.2.5.2	Acceptable alternate ground station parameter.....	44
5.3.2.5.3	Destination airport parameter	44
5.3.2.5.4	Aircraft location parameter.....	44
5.3.2.6	Ground-based initiated modification private parameters	45
5.3.2.6.1	Autotune frequency parameter	45
5.3.2.6.2	Replacement ground station list	45
5.3.2.6.3	Timer T4 parameter.....	45
5.3.2.6.4	MAC persistence parameter	45
5.3.2.6.5	Counter M1 parameter.....	46
5.3.2.6.6	Timer TM2 parameter	46
5.3.2.6.7	Timer TG5 parameter	46
5.3.2.6.8	T3min parameter	46
5.3.2.6.9	Ground station address filter parameter.....	47
5.3.2.6.10	Broadcast connection parameter.....	47
5.3.2.7	Ground-based initiated information private parameters	48
5.3.2.7.1	Frequency support list	48
5.3.2.7.2	Airport coverage indication parameter	48
5.3.2.7.3	Nearest airport parameter	48
5.3.2.7.4	ATN router NETs parameter	49
5.3.2.7.5	Ground-based system mask parameter	49
5.3.2.7.6	Timer TG3 parameter	49

5.3.2.7.7	Timer TG4 parameter	50
5.3.2.7.8	Ground station location parameter.....	50
5.3.3	VME service system parameters.....	50
5.3.4	VME procedures.....	50
5.3.4.1	Minimum frequency dwell time procedure	50
5.3.4.1.1	Purpose	50
5.3.4.1.2	Use.....	51
5.3.4.1.3	Procedure.....	51
5.3.4.1.4	Recommendation.....	51
5.3.4.2	Maximum idle activity time procedure	51
5.3.4.2.1	Purpose	51
5.3.4.2.2	Use.....	51
5.3.4.2.3	Procedure.....	51
5.3.4.3	Maximum time between transmissions procedure	51
5.3.4.3.1	Purpose	51
5.3.4.3.2	Use.....	51
5.3.4.3.3	Procedure.....	51
5.3.4.4	Maximum time between GSIFs.....	52
5.3.4.4.1	Purpose	52
5.3.4.4.2	Use.....	52
5.3.4.4.3	Procedure.....	52
5.3.4.5	Maximum link overlap time procedure	52
5.3.4.5.1	Purpose	52
5.3.4.5.2	Use.....	52
5.3.4.5.3	Procedure.....	52
5.3.5	Description of LME procedures.....	52
5.3.5.1	Frequency management procedures	56
5.3.5.1.1	Frequency search	56
5.3.5.1.2	Frequency recovery	56
5.3.5.2	Link connectivity procedures	57
5.3.5.3	Ground station identification.....	57
5.3.5.4	Link establishment	57
5.3.5.4.1	Aircraft initiation	57
5.3.5.4.2	General ground response	57
5.3.5.4.3	Exceptional cases.....	58
5.3.5.5	Link parameter modification.....	58
5.3.5.5.1	Ground-based initiation	58
5.3.5.5.2	General aircraft response	58
5.3.5.5.3	Recommendation.....	58
5.3.5.6	Aircraft-initiated handoff	58
5.3.5.6.1	Aircraft handoff	58
5.3.5.6.2	Site selection preference.....	58
5.3.5.6.3	Recommendation.....	59
5.3.5.6.4	Interaction of LMEs	59
5.3.5.6.5	General ground response	59
5.3.5.6.6	Disconnecting old link.....	59
5.3.5.6.7	Exceptional cases.....	59
5.3.5.7	Aircraft-requested ground-initiated handoff	59
5.3.5.7.1	Aircraft action.....	59
5.3.5.7.2	General ground response	60
5.3.5.7.3	Exceptional cases.....	60
5.3.5.8	Ground-based initiated handoff.....	60
5.3.5.8.1	Ground action	60
5.3.5.8.2	General aircraft response	60
5.3.5.8.3	Disconnecting old link.....	60
5.3.5.8.4	Exceptional cases.....	60
5.3.5.8.5	Recommendation.....	60
5.3.5.9	Ground-based requested aircraft-initiated handoff.....	60
5.3.5.9.1	Ground action	61
5.3.5.9.2	General aircraft response	61
5.3.5.9.3	Exceptional cases.....	61
5.3.5.9.4	Recommendation.....	61

5.3.5.10	Ground-based requested broadcast handoff	61
5.3.5.10.1	Ground action	61
5.3.5.10.2	Aircraft response	61
5.3.5.10.3	Exceptional cases.....	62
5.3.5.11	Ground-based commanded autotune	62
5.3.5.11.1	Ground action	62
5.3.5.11.2	General aircraft response	62
5.3.5.11.3	Exceptional cases.....	62
5.3.5.12	Expedited subnetwork connection management	62
5.3.5.12.1	Initiating station of subnetwork connection management	63
5.3.5.12.2	General responder action	63
5.3.5.12.3	Exceptional cases.....	63
6	Subnetwork layer protocols and services functional specifications	63
6.1	Architecture	63
6.1.1	Access points	63
6.2	Services	63
6.2.1	Subnetwork connection management	64
6.2.2	Packet fragmentation and reassembly.....	64
6.2.3	Error recovery	64
6.2.3.1	Recommendation	64
6.2.4	Connection flow control	64
6.2.4.1	Recommendation	64
6.3	Packet format.....	64
6.3.1	General format identifier	64
6.3.2	Calling and called DTE addresses	64
6.3.2.1	Encoding	65
6.3.2.1.1	Address field.....	65
6.3.2.2	Aircraft DTE address	65
6.3.2.3	Ground DTE address.....	65
6.3.2.4	Ground network DTE addresses	65
6.3.3	Call user data field	65
6.3.4	Packet types	65
6.4	Subnetwork layer service system parameters	65
6.4.1	Packet size	66
6.4.2	Parameter W (transmit window size).....	66
6.4.3	Parameter A (acknowledgment window size)	66
6.5	Effects of layers 1 and 2 on the subnetwork layer.....	66
6.6	Description of procedures	66
6.6.1	Supported facilities	67
6.6.2	Unsupported facilities	67
6.6.3	Subnetwork establishment and connection management.....	67
6.6.3.1	Subnetwork entity initialization	68
6.6.3.2	Subnetwork connection establishment	68
6.6.3.2.1	Explicit subnetwork connection establishment.....	68
6.6.3.2.2	Expedited subnetwork connection establishment.....	68
6.6.3.3	Subnetwork connection maintenance.....	68
6.6.3.3.1	Explicit subnetwork connection maintenance	68
6.6.3.3.2	Expedited subnetwork connection maintenance.....	69
6.6.3.3.3	Broadcast subnetwork connection maintenance	69
6.6.4	Error handling	69
6.6.5	Acknowledgements.....	69
7	The VDL mobile SubNetwork Dependent Convergence Function (SND CF)	69
7.1	Introduction	69
7.2	New function	69
7.3	Call user data encoding	70
7.3.1	ISH PDU.....	70
7.3.2	Maintained/initialized status bit.....	70
7.3.3	Call request	70
7.3.4	Call confirmation	70
8	Link layer test cases	70

8.1	MAC sublayer test cases	70
8.1.1	Test of listen before talk MAC (NH)	70
8.1.1.1	Purpose	70
8.1.1.2	Test architecture	70
8.1.1.3	Test scenario	70
8.1.2	Test of minimal MAC performance (NH)	70
8.1.2.1	Purpose	70
8.1.2.2	Test architecture	71
8.1.2.3	Test scenarios	71
8.1.3	Test of p-persistent MAC performance on idle channel (CP)	71
8.1.3.1	Purpose	71
8.1.3.2	Test architecture	71
8.1.3.3	Test scenarios	71
8.1.4	Test of p-persistent MAC performance on busy channel (CP)	73
8.1.4.1	Purpose	73
8.1.4.2	Test architecture	73
8.1.4.3	Test scenarios	73
8.2	Data link sublayer test cases	75
8.2.1	Test of maximum time between GSIF transmissions (IT)	75
8.2.1.1	Purpose	75
8.2.1.2	Test architecture	75
8.2.1.3	Test scenario	75
8.2.2	Test of link establishment (IT)	76
8.2.2.1	Purpose	76
8.2.2.2	Test architecture	76
8.2.2.3	Test scenario	76
8.2.3	Test of IUT link parameters recovery (CP)	76
8.2.3.1	Purpose	76
8.2.3.2	Test architecture	76
8.2.4	Test of received AVLC frame format (NH)	77
8.2.4.1	Purpose	77
8.2.4.2	Test architecture	77
8.2.4.3	Test scenario	77
8.2.5	Test of transmitted AVLC frames format (IT)	77
8.2.5.1	Purpose	77
8.2.5.2	Test architecture	77
8.2.5.3	Test scenario	77
8.2.6	Test of retransmission procedure of unacknowledged frames other than XID (CP)	77
8.2.6.1	Purpose	77
8.2.6.2	Test architecture	77
8.2.6.3	Test scenario	78
8.2.7	Test of maximum window size (NH)	89
8.2.7.1	Purpose	89
8.2.7.2	Test architecture	89
8.2.7.3	Test scenario	89
8.2.8	Test of window size (CP)	89
8.2.8.1	Purpose	89
8.2.8.2	Test architecture	90
8.2.8.3	Test scenario	90
8.2.9	Test of maximum acknowledgement delay (IT)	90
8.2.9.1	Purpose	90
8.2.9.2	Test architecture	90
8.2.9.3	Test scenario	90
8.2.10	Test of acknowledgement delay (CP)	90
8.2.10.1	Purpose	90
8.2.10.2	Test architecture	90
8.2.10.3	Test scenario	90
8.2.11	Test of retransmission procedure of unacknowledged XID (CP)	90
8.2.11.1	Purpose	90
8.2.11.2	Test architecture	90
8.2.11.3	Test scenario	91
8.2.12	Test of minimal link monitoring (IT)	96

8.2.12.1	Purpose.....	96
8.2.12.2	Test architecture	96
8.2.12.3	Test scenario	96
8.2.13	Test of link monitoring (CP).....	96
8.2.13.1	Purpose.....	96
8.2.13.2	Test architecture	97
8.2.13.3	Test scenario	97
8.2.14	Test of illegal reception (IT).....	97
8.2.14.1	Purpose.....	97
8.2.14.2	Test architecture	97
8.2.14.3	Test scenario	97
8.2.15	Test of time between GSIF transmissions (CP).....	97
8.2.15.1	Purpose.....	97
8.2.15.2	Test architecture	97
8.2.15.3	Test scenario	97
8.2.16	Test of maximal link overlap (IT).....	98
8.2.16.1	Purpose.....	98
8.2.16.2	Test architecture	98
8.2.16.3	Test scenario	98
8.2.17	Test of link hand-off (CP).....	98
8.2.17.1	Purpose.....	98
8.2.17.2	Test architecture	98
8.2.17.3	Test scenario	99
8.2.18	Frame collision with tester precedence test	99
8.2.18.1	Purpose.....	99
8.2.18.2	Test architecture	99
8.2.18.3	Test scenario	99
8.2.19	Frame collision with IUT precedence test	99
8.2.19.1	Purpose.....	99
8.2.19.2	Test architecture	99
8.2.19.3	Test scenario	99
8.2.20	Selective acknowledgement test	99
8.2.21	Purpose	99
8.2.22	Test architecture.....	99
8.2.23	Test scenario	100
8.3	Test summary	100
8.4	PCO summary	100
Annex A (informative): Bibliography.....		101
History		106

Intellectual Property Rights

IPRs essential or potentially essential to the present document may have been declared to ETSI. The information pertaining to these essential IPRs, if any, is publicly available for **ETSI members and non-members**, and can be found in ETSI SR 000 314: "*Intellectual Property Rights (IPRs); Essential, or potentially Essential, IPRs notified to ETSI in respect of ETSI standards*", which is available from the ETSI Secretariat. Latest updates are available on the ETSI Web server (<http://webapp.etsi.org/IPR/home.asp>).

Pursuant to the ETSI IPR Policy, no investigation, including IPR searches, has been carried out by ETSI. No guarantee can be given as to the existence of other IPRs not referenced in ETSI SR 000 314 (or the updates on the ETSI Web server) which are, or may be, or may become, essential to the present document.

Foreword

This European Standard (Telecommunications series) has been produced by ETSI Technical Committee Electromagnetic compatibility and Radio spectrum Matters (ERM).

The present document is part 2 of a multi-part deliverable covering VHF air-ground Digital Link (VDL) Mode 2; Technical characteristics and methods of measurement for ground-based equipment, as identified below:

Part 1: "Physical layer and MAC sublayer";

Part 2: "Upper layers".

National transposition dates	
Date of adoption of this EN:	26 March 2004
Date of latest announcement of this EN (doa):	30 June 2004
Date of latest publication of new National Standard or endorsement of this EN (dop/e):	31 December 2004
Date of withdrawal of any conflicting National Standard (dow):	31 December 2004

Introduction

The present document states the technical specifications for ground-based equipment implementing Very High Frequency (VHF) Digital Link (VDL) Mode 2 air interface, operating in the VHF band (117,975 MHz to 137 MHz) with 25 kHz channel spacing.

Manufacturers should note that in the future, all or part of the frequency band 108,000 MHz to 117,975 MHz may become available for aeronautical communications.

The present document may be used to produce tests for the assessment of the performance of the equipment. The performance of the equipment submitted for type testing should be representative of the performance of the corresponding production model.

The present document has been written on the assumption that:

- the type test measurements will be performed only once, in an accredited test laboratory, and the measurements accepted by the various authorities in order to grant type approval;
- if equipment available on the market is required to be checked it will be tested in accordance with the methods of measurement specified in the present document.

1 Scope

The present document applies to VDL Mode 2 ground-air digital communications using Differential Eight Phase Shift Keying (D8PSK), intended for channel separations of 25 kHz. The VDL Mode 2 system provides data communication exchanges between aircraft and ground based systems. The scope of the present document is limited to ground based stations.

The VDL Mode 2 system is designed to be an Air/Ground sub-system of the Aeronautical Telecommunication Network (ATN) using the AM(R)S band and it is organized according to the Open Systems Interconnection (OSI) model (defined by ISO). It shall provide reliable subnetwork services to the ATN system.

The present document provides functional specifications for ground-based radio transmitters, receivers, and transceivers intended to be used for ground-air data communications. The present document is derived from the following documents:

- VDL Mode 2 SARPs version 3.0. ICAO, annex 10 Volume III part I [1];
 - Minimum Operational Performance Standards for Airborne Radio Communications Equipment Operating within the Radio Frequency Range 117,975 MHz to 137,000 MHz [2];
- that specify the airborne transmission system.

The present document consists of two parts:

- The first part provides functional specifications and test procedures for physical layer.
- The second part provides functional specifications and test procedures for link and sub-network access layers.

2 References

The following documents contain provisions which, through reference in this text, constitute provisions of the present document.

- References are either specific (identified by date of publication and/or edition number or version number) or non-specific.
- For a specific reference, subsequent revisions do not apply.
- For a non-specific reference, the latest version applies.

Referenced documents which are not found to be publicly available in the expected location might be found at <http://docbox.etsi.org/Reference>.

- [1] Annex 10 to the Convention on International Civil Aviation, International Civil Aviation Organization.

NOTE: The standards for Mode 2 are still in a process of evolution at the time of preparation of the present document. The revised standards material has been accepted for publication in annex 10 although there is likely to be a small amount of final editing and correction. The most up to date references consist of two documents (1a - 1b in the table below) which represent the output from the seventh meeting of the Aeronautical Mobile Communications Panel (AMCP), 22nd March to 30th March 2000, Montreal.

1a	VHF Air-Ground Digital Link (VDL) Standards and Recommended Practices (SARPs), Appendix A to the Report on Agenda Item 2, AMCP/7-WP/81
1b	Manual on VHF Digital Link (VDL) Mode 2 Technical Specifications, Appendix A to the Report on Agenda Item 5, AMCP/7-WP/81

- [2] DO-186A: "Minimum Operational Performance Standards for Airborne Radio Communications Equipment Operating within the Radio Frequency Range 117.975 - 137.000 MHz".

- [3] ISO/IEC 7498-1 (1994): "Information technology - Open Systems Interconnection - Basic Reference Model: The Basic Model".
- [4] ISO/IEC 10731 (1994): "Information technology - Open Systems Interconnection - Basic Reference Model - Conventions for the definition of OSI services".
- [5] ISO/IEC 8208 (2000): "Information technology - Data communications - X.25 Packet Layer Protocol for Data Terminal Equipment".
- [6] ISO/IEC 15802-1 (1995): "Information technology - Telecommunications and information exchange between systems - Local and metropolitan area networks - Common specifications - Part 1: Medium Access Control (MAC) service definition".
- [7] ISO/IEC 13239 (2002): "Information technology - Telecommunications and information exchange between systems - High-level data link control (HDLC) procedures".
- [8] ETSI EN 301 841-1: "Electromagnetic compatibility and Radio spectrum Matters (ERM); VHF air-ground Digital Link (VDL) Mode 2; Technical characteristics and methods of measurement for ground-based equipment; Part 1: Physical layer and MAC sub-layer".
- [9] ITU-T Recommendation X.25: "Interface between Data Terminal Equipment (DTE) and Data Circuit-terminating Equipment (DCE) for terminals operating in the packet mode and connected to public data networks by dedicated circuit".

3 Definitions and abbreviations

3.1 Definitions

3.1.1 Basic reference model definitions

The present document is based on the concepts developed in the open systems interconnect basic reference model and makes use of the following terms defined in ISO/IEC 7498-1 [3]:

- layer;
- sublayer;
- entity;
- service;
- service access point;
- service data unit;
- physical layer;
- data link layer.

3.1.2 Service conventions definitions

The present document makes use of the following terms defined in ISO/IEC 10731 [4]:

- service provider;
- service user;
- service primitive;
- request;

- indication;
- confirm.

3.1.3 General definitions

For the purposes of the present document, the following terms and definitions apply:

aeronautical mobile service: mobile service between aeronautical stations and aircraft stations, or between aircraft stations, in which survival craft stations may participate

data rate: Mode 2 symbol rate shall be 10 500 symbols/s, with a nominal data rate of 31 500 bits/s

ground base station: aeronautical station equipment, in the aeronautical mobile service, for use with an external antenna and intended for use at a fixed location

mobile equipment: radio equipment designed for installation into vehicles

radiated measurements: measurements which involve the measurement of a radiated field

3.2 Abbreviations

For the purposes of the present document, the following abbreviations apply:

ABM	Asynchronous Balanced Mode
ACK	ACKnowledge(ment)
ADM	Asynchronous Disconnected Mode
AM(R)S	Aeronautical Mobile (Route) Service
ARS	Administration Region Selector
ATN	Aeronautical Telecommunication Network
AV2M	Aviation VHF Data Link Mode 2 Mac Layer
AV2MAP	AV2M Access Point
AV2MDU	AV2M Data Unit
AV2MPDU	AV2M Packet Data Unit
AVDLC	Aviation VHF Data Link Control
AVLC	Aviation VHF Link Control
AVLC-SN	AVLC-Sequence Number
BCD	Binary Coded Decimal
C/R	Command/Response (bit)
CCIR	International Radio Consultative Committee
CMD	CoMmanD (frame)
CSC	Common Signalling Channel
CSMA	Carrier Sense Multiple Access
D8PSK	Differentially encoded 8 Phase Shift Keying
D-bit	ISO/IEC 8208 Delivery bit
DCE	Data Circuit-terminating Equipment
DISC	DISConnect (frame)
DLE	Data Link Entity
DLS	Data Link Service
DM	Disconnected Mode (frame)
DTE	Data Terminal Equipment
DXE	Either: Data terminal Equipment or Data circuit-terminating Equipment
FCS	Frame Check Sequence
FEC	Forward Error Correction
FRM	Frame Reject Mode
GSIF	Ground Station Information Frame
HDLC	High-level Data Link Control
HO	Hand-Off
HTC	Highest Two-way Channel
IA5	The character set defined in ISO/IEC 646, table 5
ICAO	International Civil Aviation Organization
ID	IDentification (identifier)

INFO	INFOrmation (frame)
IS	Intermediate System
ISH	Intermediate System Hello (packet)
ISO	International Organization for Standardization
LCI	Logical Channel Identifier
LCR	Link Connection Refused
LME	Link Management Entity
LTC	Lowest Two-way Channel
M/I	Maintained/Initialized status bit
MAC	Media Access Control
MSK	Minimum Shift Keying
NET	Network Entity Title
OSI	Open Systems Interconnection
PCO	Point of Control and Observation
P/F	Poll/Final (bit)
PDU	Protocol Data Unit
Q-bit	ISO/IEC 8208 Qualifier bit
RF	Radio Frequency
RNR	Receive Not Ready (frame)
RR	Receive Ready (frame)
RSP	ReSPonse (frame)
SARP	Standard And Recommended Practice
SME	System Management Entity
SN	SubNetwork
SNAcP	SubNetwork Access Protocol
SNDCF	SubNetwork Dependent Convergence Function
SNPA	SubNetwork Point of Attachment
SNSAP	SubNetwork Service Access Point
SQP	Signal Quality Parameter
SREJ	Selective ReJect (frame)
SRM	Sent selective Reject Mode
SVC	Switched Virtual Circuit
UA	Unnumbered Acknowledgment (frame)
UI	Unnumbered Information (frame)
VDL	VHF Digital Link
VHF	Very High Frequency
VME	VDL Management Entity
XID	eXchange ID (frame)

4 General architecture of VDL Mode 2

The general architecture of the VHF radio equipment operating in VDL Mode 2 is depicted in figure 4.. This figure presents the different functional parts of the VDL Mode 2 equipment.

The VDL system is related to the three lower layers of the OSI model providing services described as follows:

Layer 1 (Physical layer): provides transceiver frequency control, bit exchanges over the radio media, and notification functions. These functions are often known as radio and modulation functions. The physical layer handles information exchanges at the lowest level and manipulates bits. The physical layer handles modulation, data encoding and includes a forward error correction mechanism based on interleaving and Reed Solomon coding. The physical layer is specified in EN 301 841-1 [8].

Layer 2 (Link Layer): is split into two sublayers and a link management entity:

- The Media Access Control (MAC) sublayer provides access to the Physical layer by a Carrier Sense Multiple Access (CSMA) algorithm in charge of channel access. The Medium Access Control (MAC) layer controls channel access and sharing. This sublayer is specified in clause 5.1.
- The Data Link Services (DLS) sublayer is composed of the Aviation VHF Link Control (AVLC) derived from the High level Data Link Control (HDLC) protocol (ISO/IEC 13239 [7]) whose main functions are frame exchanges, frame processing, and error detection. This sublayer is specified in clause 5.2.

- The Link Management Entity (LME) controls the link establishment and maintenance between DLS sublayers. This management entity is specified in clause 5.3.5.

Layer 3: Only the lowest network sublayer of layer 3 (SNAcP) will be described in the present document. It is compliant with the subnetwork sublayer requirements defined in the ATN SARPs and conforms with the ISO/IEC 8208 [5] (or network layer of ITU-T Recommendation X.25 [9]). It provides packet exchanges over a virtual circuit, error recovery, connection flow control, packet fragmentation, and subnetwork connection management functions. The SNAcP is specified in clause 6.

Layer 1 is specified in EN 301 841-1 [8].

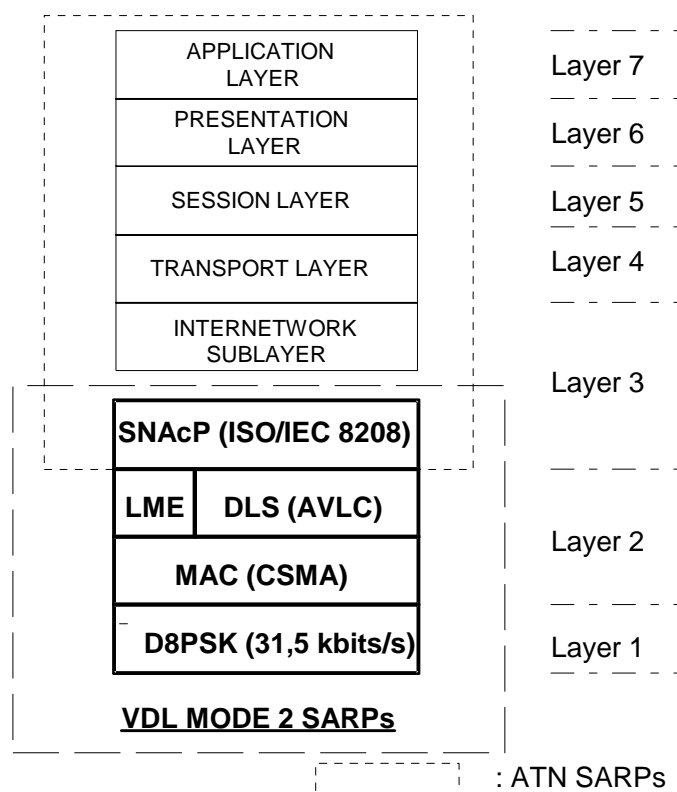

Figure 4.1: VDL SARPs in the ATN/OSI Organization

5 Link layer protocols and services functional specifications

The link layer protocols are divided into two classic layers: the Medium Access Control sublayer and the Data link sublayer protocol.

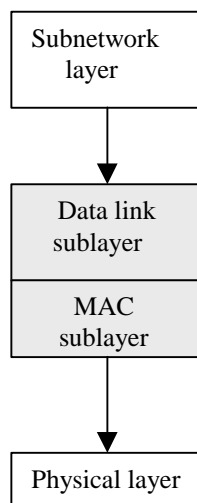

Figure 5.1: Link layer architecture

The interface between the MAC sub layer and the data link sublayer is commanded by the primitive AV2M-UNITDATA and AV2M-STATUS indication. The AV2M-UNITDATA request carries in parameter an AVDLC frame.

5.1 MAC sublayer specifications

The MAC sublayer shall provide for the transparent acquisition of the shared communications path. It makes invisible to the DLS sublayer the way in which supporting communications resources are utilized to achieve this. The MAC sublayer conveys the AVLC frames to be transmitted from the upper data link sublayer to the physical layer, and the received AVLC frame from the physical layer to the upper data link sublayer. The MAC sublayer does not introduce modifications in the AVLC frames.

The service specification for the MAC sublayer is modelled in ISO/IEC 15802-1 [6].

5.1.1 MAC services

5.1.1.1 Multiple access

The MAC sublayer shall implement a non-adaptive p-persistent CSMA algorithm to equitably allow all stations the opportunity to transmit while maximizing system throughput, minimizing transit delays, and minimizing collisions.

5.1.1.2 Channel congestion

The MAC sublayer shall notify the VME sublayer whenever channel congestion is detected (see clause 5.3).

5.1.2 MAC service system parameters

The MAC service shall implement the system parameters defined in table 5.1.

Table 5.1: MAC service system parameters

Figure 5.2 Figure 5.3	Parameter name	Minimum	Maximum	Default	Increment
TM1	Inter-access delay	0,5 ms	125 ms	4,5 ms	0,5 ms
TM2	Channel busy	6 s	120 s	60 s	1 s
P	persistence	1/256	1	13/256	1/256
M1	Maximum number of access attempts	1	65 535	135	1

5.1.2.1 Timer TM1 (inter-access delay timer)

Timer TM1 shall be set to the time (TM1) that a MAC sublayer will wait between consecutive access attempts. This timer shall be started if it is not already running and the channel is idle after an unsuccessful access attempt. The timer shall be cancelled if the channel becomes busy. When the timer expires another access attempt shall be made.

5.1.2.2 Timer TM2 (channel busy timer)

Timer TM2 shall be set to the maximum time (TM2) that a MAC sublayer will wait after receiving a request to transmit. This timer shall be started if it is not already running, when the MAC sublayer receives a request for transmission. The timer shall be cancelled upon a successful access attempt. When the timer expires, the VME shall be informed that the channel is congested.

5.1.2.3 Parameter p (persistence)

Parameter p ($0 < p \leq 1$) shall be the probability that the MAC sublayer will transmit on any access attempt.

5.1.2.4 Counter M1 (maximum number of access attempts)

Counter M1 shall be set to the maximum number of attempts (M1) that a MAC sublayer will make for any transmission request. This counter shall be cleared upon system initialization, Timer TM2 expiring, or a successful access attempt. The counter shall be incremented after every unsuccessful access attempt. When the counter reaches the maximum number of attempts (M1), authorization to transmit shall be granted as soon as the channel is idle.

5.1.3 Description of procedures

5.1.3.1 Channel sensing

While attempting to access the channel, the MAC sublayer shall verify that the channel is idle as defined in the physical layer.

5.1.3.2 P-persistent CSMA access times

When the AV2M entity is in channel access procedure, the AV2M entity will wait for an access attempt time. An access attempt time is determined as soon the two following conditions are fulfilled:

- the channel is in an idle state;
- the inter-access interval has elapsed.

At each access attempt time:

- if M1 counter is below its maximum value, then the AVLC frame is transmitted with probability p ;
- if M1 counter is equal to its maximum value, then the AVLC frame is transmitted.

In every case the access attempt is considered successful when the AVLC frame is transmitted and the AV2M entity terminates the channel access procedure after the transmission by the physical protocol; otherwise the access attempt is considered unsuccessful.

5.1.3.3 Inter-access interval

The inter-access interval shall be used to separate the access attempt times determined by the AV2M entity. The inter-access interval shall be determined as follows:

- it starts from the last unsuccessful channel attempt made by this AV2M entity;
- it ends when either of the following events occurs:
 - the channel is sensed busy;
 - the channel has been sensed idle during a time T_{M1} from the last unsuccessful channel attempt.

5.1.3.4 Channel access procedure

5.1.3.4.1 Purpose

To transmit an AVLC frame via physical layer and P-persistent CSMA.

5.1.3.4.2 Use

Upon AV2M-UNITDATA request.

5.1.3.4.3 Procedure

When the AV2M entity receives an AV2M-UNITDATA request with an AVLC frame in parameter, it shall access and transmit the AVLC frame following the channel access procedure as follows:

- When starting the channel access procedure, it sets the counter M1 to zero and waits for an access attempt time;
- If the access attempt is unsuccessful, then it increments the counter M1 by one unit and waits for the next access attempt time;
- It terminates the channel access procedure as soon as a successful access attempt occurs, and then it issues an AV2M-STATUS indication.

5.1.3.5 AVLC frame reception

5.1.3.5.1 Purpose

To receive an AVLC frame via the physical layer.

5.1.3.5.2 Use

Upon reception of an AVLC frame from the physical layer.

5.1.3.5.3 Procedure

Upon reception of an AVLC frame from the physical layer, the AV2M entity issues an AV2M-UNITDATA indication with this AVLC frame as parameter.

5.2 Data link layer service protocol specifications

5.2.1 Interface with MAC sub layer

Connectionless-mode AV2MPDU transfer service primitives can be used to transfer an independent, self-contained AV2MDU from AV2MAP to another AV2MAP or a group of AV2MAPs in a single service access. It is self-contained in that all the information required to deliver the AV2MPDU is presented to the AV2M-provider in a single service access.

5.2.1.1 Sequence of primitives

Parameter	Value	Meaning
	"authorization to transmit"	This value specifies that the MAC layer can accept a new packet

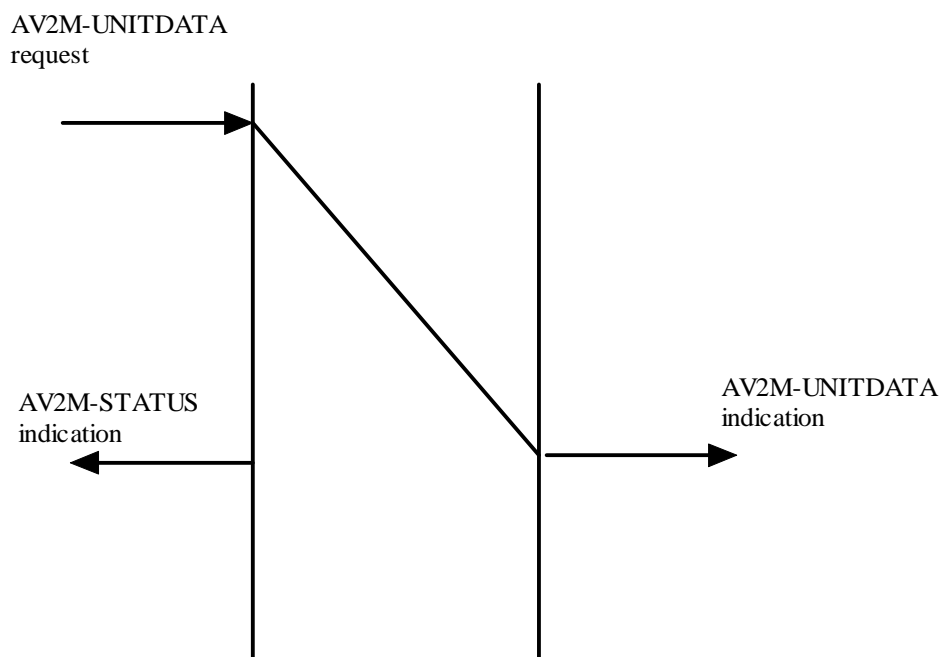

Figure 5.2: Sequence of primitives for a successful transmission of an AV2MPDU

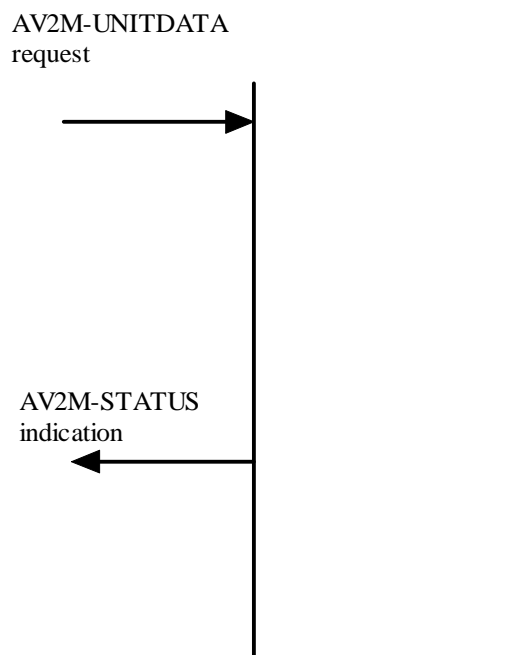

Figure 5.3: Sequence of primitives for an unsuccessful AV2MPDU transmission

In figures 5.2 and 5.3 the AV2M-STATUS indication is "authorization to transmit", since there is no way to detect unsuccessful transmissions from the transmitter side.

5.2.2 Data Link State Machines

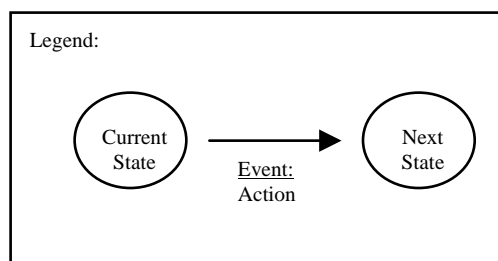

Figure 5.4: State diagram common legend

5.2.2.1 LME state machine

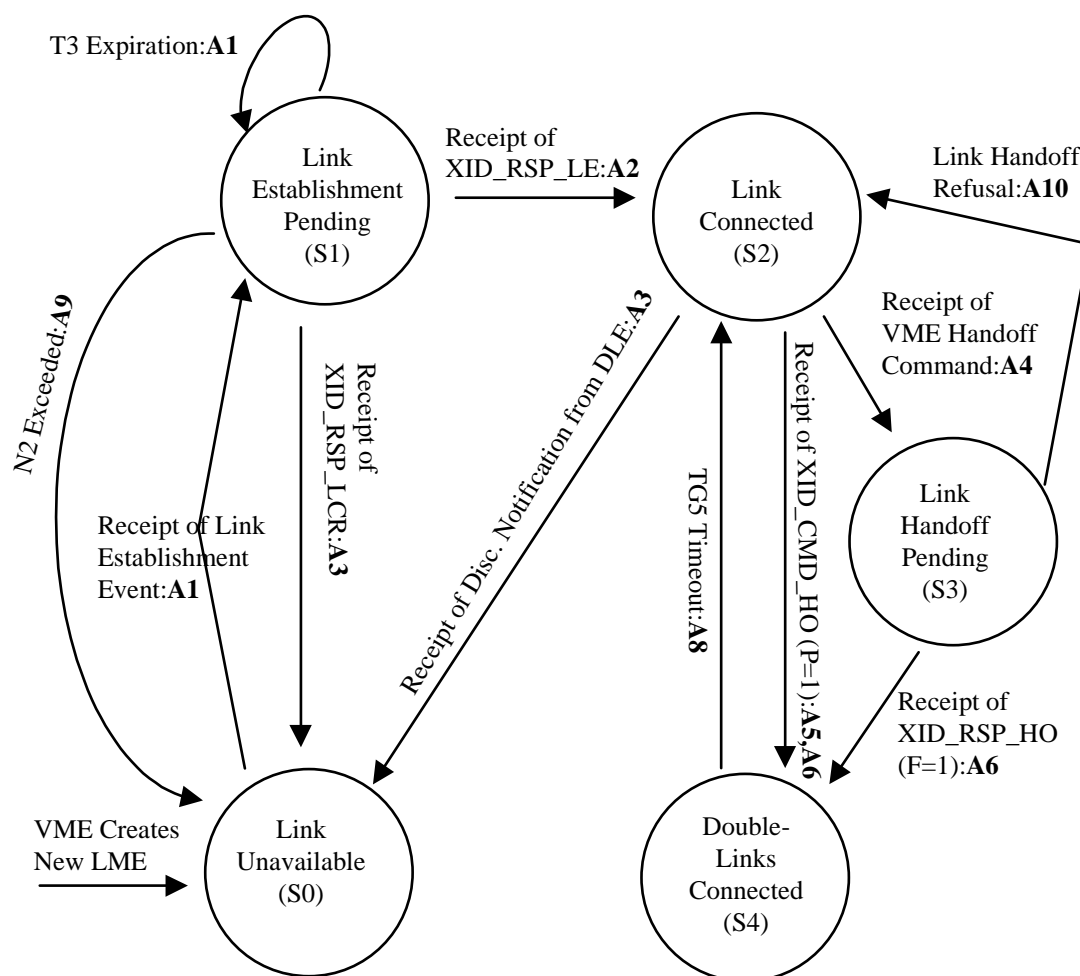

Figure 5.5: LME state machine

Starting with state S0, upon an event, the LME takes an action and makes a transition to a new state. The actions A1 through A9 are described below:

- A1: Send XID_CMD_LE (P=1) to the ground station proposed by VME. Increment N2.
- A2: Mark current ground station, set up link_id for this link connection. Create DLE.
- A3: Notify VME and wait for command from VME to establish connection with a new ground station.
- A4: Send XID_CMD_HO (P=1).
- A5: Send XID_RSP_HO (F=1).
- A6: Mark current link as "old"; mark new link as "current"; start timer TG5 on the old link.
- A7: Mark old link as terminated; notify VME of old link termination.
- A8: Maintain single link connection.
- A9: Notify VME of failure in link establishment to this ground station.
- A10: Notify VME of a handoff refusal.

5.2.2.2 DLE top state machine

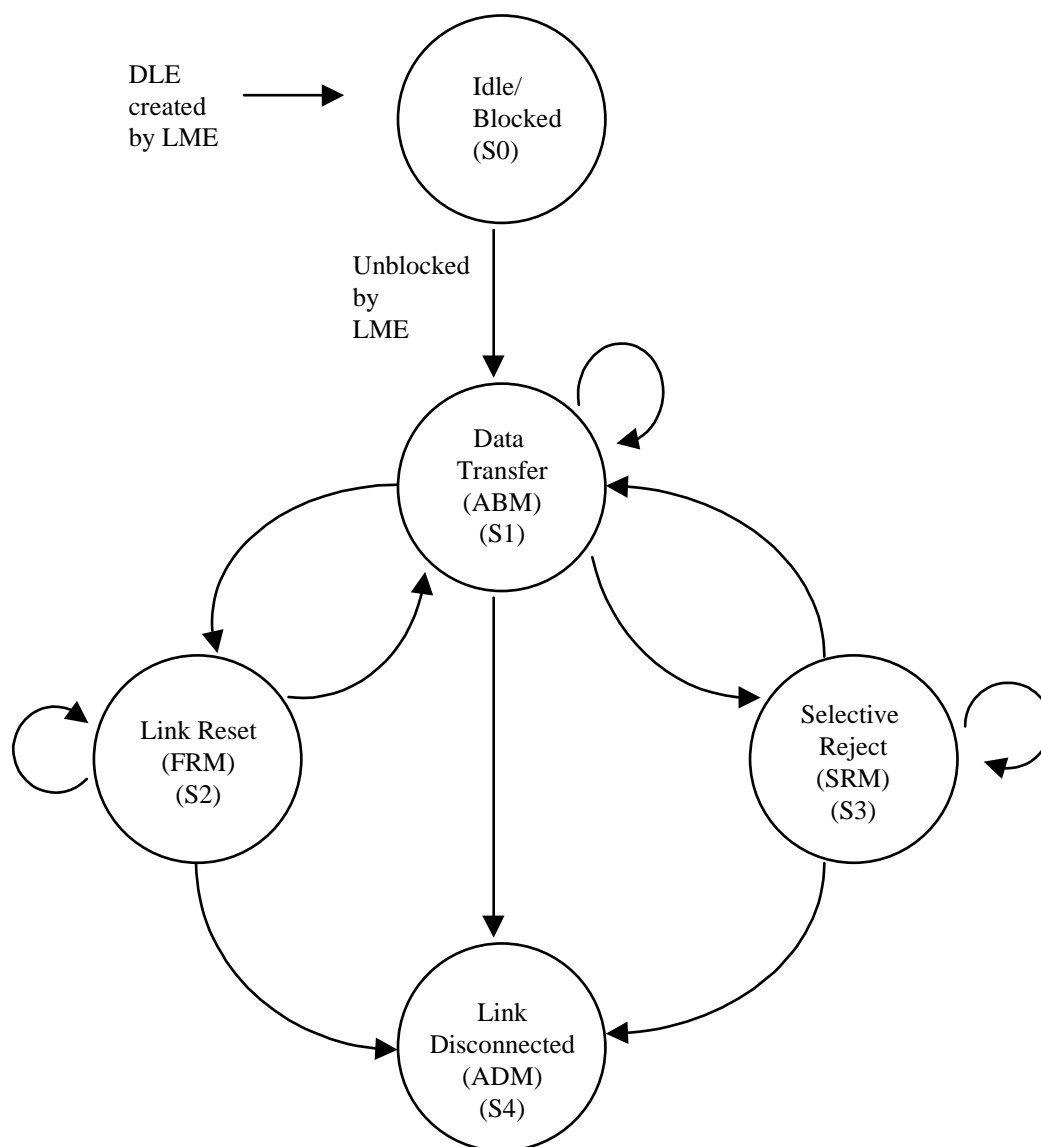

Figure 5.6: DLE top level state diagram

5.2.2.3 DLE data transfer state diagram

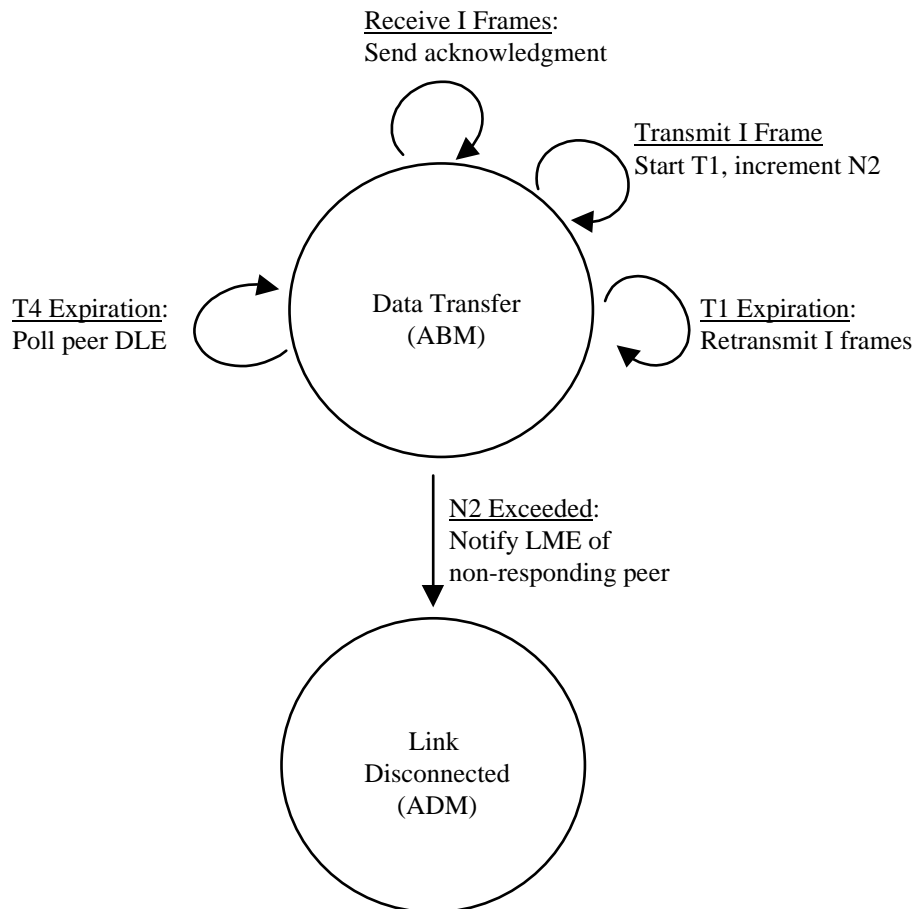

Figure 5.7: DLE data transfer (ABM) state diagram

5.2.2.4 DLE selective reject state machines

5.2.2.4.1 SRM mode Sending SREJ

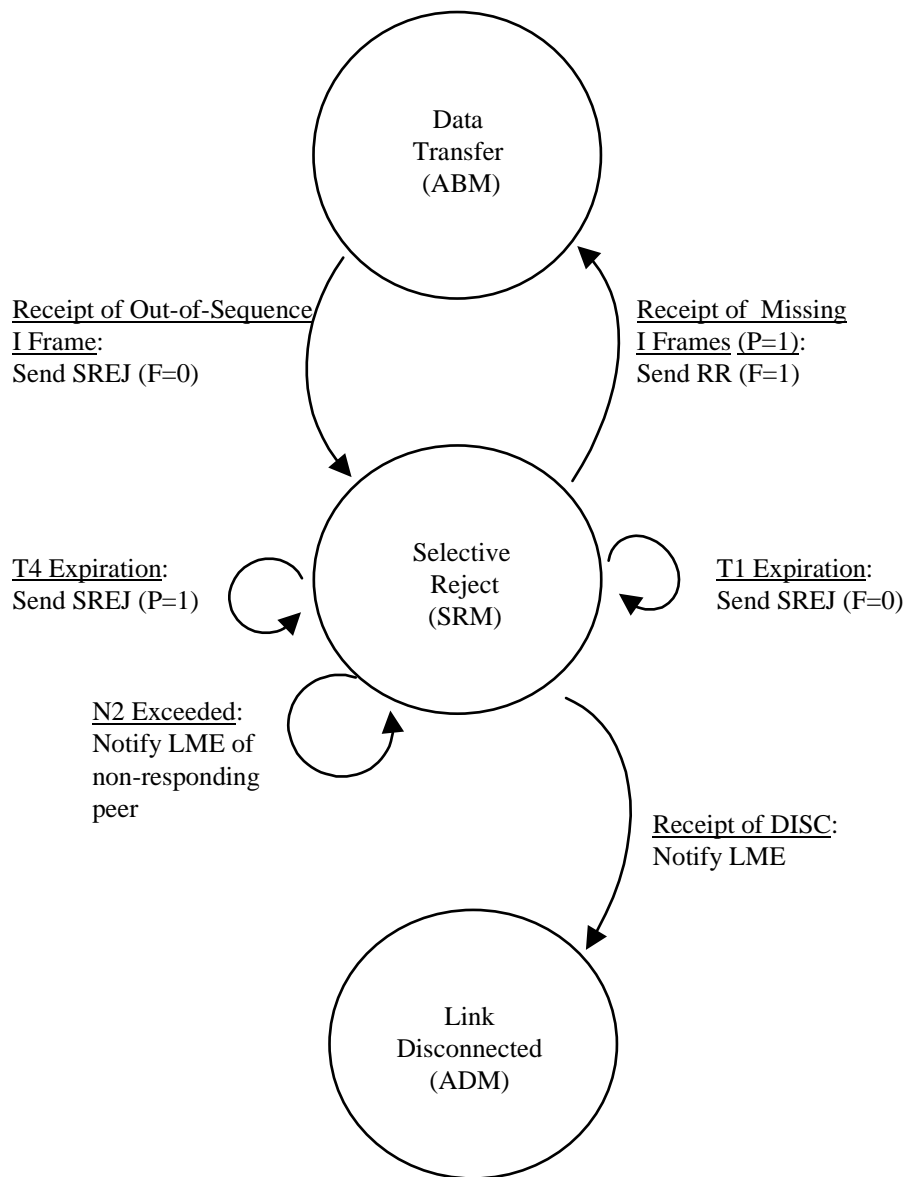

Figure 5.8: DLE selective reject (SRM) state diagram (sending SREJ)

5.2.2.4.2 SRM mode Receiving SREJ

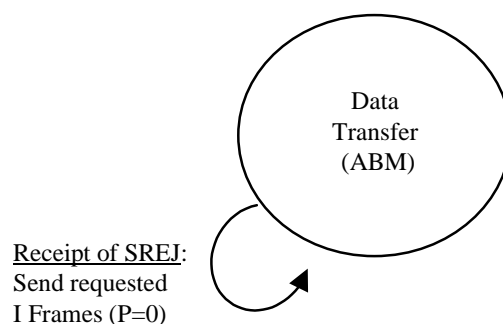

Figure 5.9: DLE selective reject (SRM) state diagram (receiving SREJ)

5.2.2.4.3 FRM mode

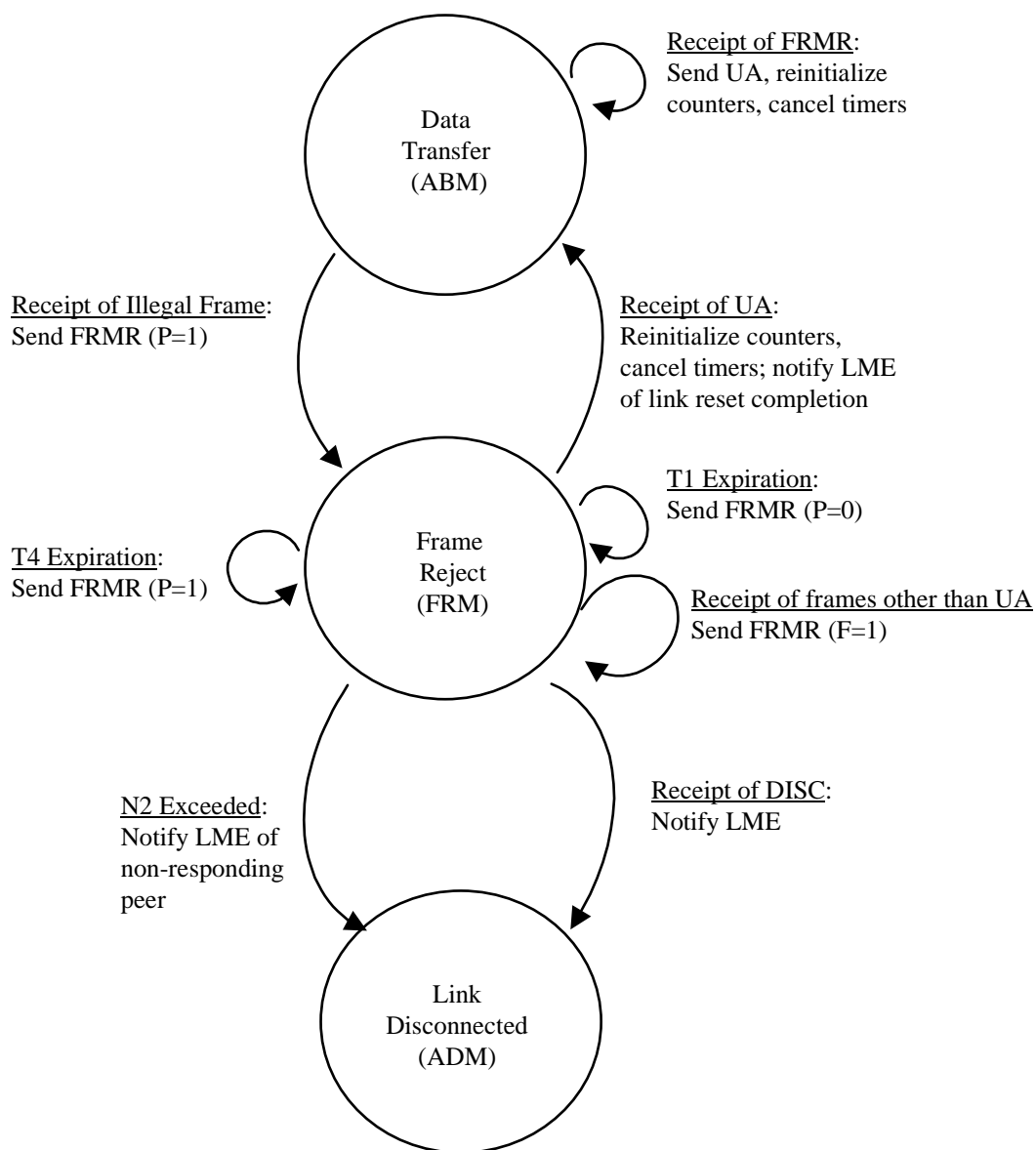

Figure 5.10: DLE selective reject (FRM) state diagram

5.2.2.5 DLE termination state machine

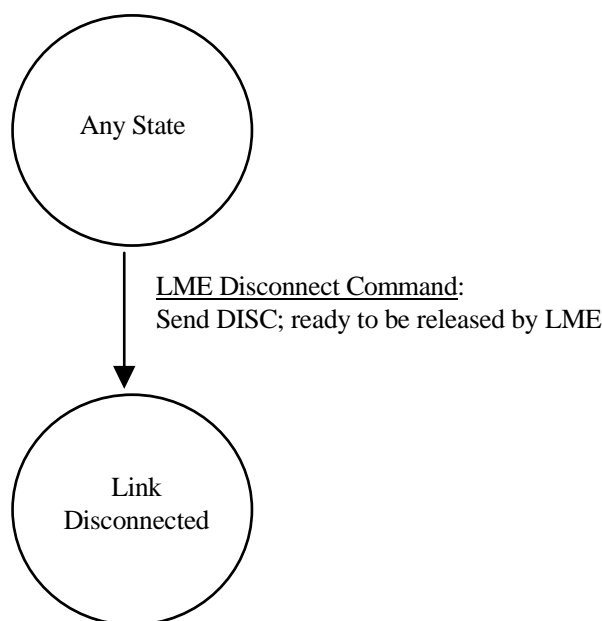

Figure 5.11: DLE termination state diagram

5.2.3 Services

5.2.3.1 Received frame sequencing procedure

The receiving DLS sublayer shall ensure that duplicated frames are discarded and all frames are delivered exactly once over a point-to-point connection.

5.2.3.1.1 Purpose

To discard any duplicated received frames.

5.2.3.1.2 Use

Upon reception of any AVLC frame contained in an AV2M-UNITDAT indication.

5.2.3.1.3 Procedure

Upon AV2M-UNITDATA indication, one shall extract the AVLC frame from the AV2M-UNITDATA indication, and perform the error detection procedure on the AVLC frame. If it is successful and if the AVLC frame is of type XID, FRMR, TEST, DISC, DM, RR, SREJ, then set VLC-SN to the sequence number of this frame. If VLC-SN identifies a duplicate frame, then discard the AVLC frame.

Sequence numbers are included in the frame format to facilitate this service.

5.2.3.2 Error detection procedure

5.2.3.2.1 Purpose

The DLS sublayer shall ensure that all frames corrupted during transmission are detected and discarded.

5.2.3.2.2 Use

In the received frame sequencing procedure, on the received AVLC frame.

5.2.3.2.3 Procedure

Use the FCS field included in the frame and verify that it correctly checks the AVLC frame as per ISO/IEC 13239 [7]. The FCS field is included in the frame format to facilitate this service.

5.2.3.3 Station identification

The DLS sublayer shall accept over a point-to-point connection only frames that are addressed to it. Unique source and destination addresses are included in the frame format to facilitate this service.

5.2.3.4 Broadcast addressing

The VDL shall support broadcast addresses that shall be recognized and acted upon by all appropriate receivers.

5.2.3.5 Data transfer

Data shall be transferred in the information fields of VDL INFO, UI and XID frames, per ISO/IEC 13239 [7]. The link layer shall process the largest packet size, specified in ISO/IEC 13239 [7] (see clause 6 of the present document), without segmenting. Only one data link user packet shall be contained in an INFO or UI.

5.2.4 Frame format

AVLC frames shall conform to ISO/IEC 13239 [7] frame structure except as specified in figure 5.12.

Description	Octet	Bit number in octet - first bit transmitted							
		8	7	6	5	4	3	2	1
FLAG		0	1	1	1	1	1	1	0
Destination Address Field	1	da ₂₂	da ₂₃	Da ₂₄	da ₂₅	da ₂₆	da ₂₇	A/G	0
	2	da ₁₅	da ₁₆	Da ₁₇	da ₁₈	da ₁₉	da ₂₀	Da ₂₁	0
	3	da ₈	da ₉	Da ₁₀	da ₁₁	da ₁₂	da ₁₃	Da ₁₄	0
	4	da ₁	da ₂	Da ₃	da ₄	da ₅	da ₆	da ₇	1
Source Address Field	5	sa ₂₂	sa ₂₃	Sa ₂₄	sa ₂₅	sa ₂₆	sa ₂₇	C/R	0
	6	sa ₁₅	sa ₁₆	Sa ₁₇	sa ₁₈	sa ₁₉	sa ₂₀	sa ₂₁	0
	7	sa ₈	sa ₉	Sa ₁₀	sa ₁₁	sa ₁₂	sa ₁₃	sa ₁₄	0
	8	sa ₁	sa ₂	Sa ₃	sa ₄	sa ₅	sa ₆	sa ₇	1
Link Control Field	9	control field bits							
INFORMATION	N-2	USER DATA							
Frame Check Sequence	N-1	Most significant octet							
	N	Least significant octet							
FLAG		0	1	1	1	1	1	1	0

Figure 5.12: Link layer frame format

5.2.4.1 Address structure

The address field shall consist of eight octets. As described in ISO/IEC 13239 [7] option 7, the least significant (first transmitted) bit of each octet shall be reserved for address extension. When set to binary 0 it shall indicate that the rest of the following octet is an extension of the address field. The presence of binary 1 in the first transmitted bit of the address octet shall indicate that the octet is the final octet of the address field.

5.2.4.2 Address fields

The address field shall contain a destination address field and a source address field. The destination address field shall contain a destination DLS address or a broadcast address. The source address field shall contain a DLS address. There is a status bit in the source address, and a status bit in the destination address field, which shall be set by the transmitting station to reflect status information. The status bits and address details are defined in clauses 5.2.4.2.1 to 5.2.4.2.7.

5.2.4.2.1 Air-ground status bit

The status bit in the destination address field (bit 2, octet 1) shall be the air-ground bit. The air-ground bit shall be set to 0 to indicate that the transmitting station is airborne. It shall be set to 1 to indicate that the transmitting station, either fixed or mobile, is on the ground. The default value for the air-ground bit shall be 0 for aircraft that do not provide this information at the link level; the value shall be 1 for ground stations.

5.2.4.2.2 Command/response status bit

The status bit in the source address field (bit 2, octet 5) shall be the Command/Response (C/R) bit. The C/R bit shall be set to 0 to indicate a command frame, and set to 1 to indicate a response frame.

5.2.4.2.3 Data link service addresses

The DLS address shall be 27 bits, divided into a 3-bit type field and a 24-bit specific address field. The 27 bits of the destination address are respectively denoted $da_1, da_2, da_3, da_4, da_5, da_6, da_7, da_8, da_9, da_{10}, da_{11}, da_{12}, da_{13}, da_{14}, da_{15}, da_{16}, da_{17}, da_{18}, da_{19}, da_{20}, da_{21}, da_{22}, da_{23}, da_{24}, da_{25}, da_{26}, da_{27}$. The 27 bits of the DLS source address are respectively denoted $sa_1, sa_2, sa_3, sa_4, sa_5, sa_6, sa_7, sa_8, sa_9, sa_{10}, sa_{11}, sa_{12}, sa_{13}, sa_{14}, sa_{15}, sa_{16}, sa_{17}, sa_{18}, sa_{19}, sa_{20}, sa_{21}, sa_{22}, sa_{23}, sa_{24}, sa_{25}, sa_{26}, sa_{27}$.

5.2.4.2.4 Address type

The address type field is described in table 5.2.

Table 5.2: Address type field encoding

Bit number			Description type	Comments
Da ₂₇	da ₂₆	da ₂₅		
Sa ₂₇	sa ₂₆	sa ₂₅		
Bit encoding				
0	0	0	reserved	Future use
0	0	1	Aircraft	24-bit ICAO address
0	1	0	reserved	Future use
0	1	1	reserved	Future use
1	0	0	Ground station	ICAO-administered address space
1	0	1	Ground station	ICAO-delegated address space
1	1	0	reserved	Future use
1	1	1	All stations broadcast	All stations

5.2.4.2.5 Aircraft specific addresses

The aircraft specific address field shall be the 24-bit ICAO aircraft address.

5.2.4.2.6 ICAO-administered ground station specific addresses

The ICAO-administered ground station specific address shall consist of a variable-length country code prefix (using the same country code assignment defined in ICAO, annex 10 [1], volume III, chapter 9, appendix 1, table 1) and a suffix. The appropriate authority shall assign the bits in the suffix.

5.2.4.2.7 ICAO-delegated ground station specific addresses

The ICAO-delegated ground station specific address shall be determined by the organization to which the address space is delegated.

5.2.4.3 Broadcast address

The broadcast address shall be used only as a destination address for Unnumbered Information (UI) frames or for XID frames broadcasting ground station information.

5.2.4.3.1 Encoding

The broadcast addresses shall be encoded as in table 5.3.

Table 5.3: Broadcast address encoding

Broadcast destination	Type field	Specific address field	
All aircraft	001	All ones	
All ground stations of a particular provider	100 or 101, as necessary	<i>Most significant bits</i>	<i>Remaining bits</i>
		Variable length provider code	All ones
All ground stations with ICAO-administered addresses	100	All ones	
All ground stations	101	All ones	
All stations	111	All ones	

5.2.4.4 Link control field

The basic repertoire of commands and responses for AVLC shall be as detailed in table 5.4 and shall be encoded as per ISO/IEC 13239 [7] as shown in table 5.5.

Table 5.4: AVLC commands and responses

Commands	Responses
INFO [Information]	INFO
RR [Receive Ready]	RR
XID [Exchange Identity]	XID
TEST	TEST
SREJ [Selective Reject]	SREJ [Selective Reject]
FRMR [Frame Reject]	
UI [Unnumbered INFO]	UA [Unnumbered Acknowledge]
DISC [Disconnect]	DM [Disconnected mode]

Table 5.5: Control field formats

Control field format for	Control field bits							
	1	2	3	4	5	6	7	8
Information transfer commands/response (I format)	0	N(S)			P/F	N(R)		
Supervisory commands/responses (S format)	1	0	S	S	P/F	N(R)		
Unnumbered commands/responses (U format)	1	1	M	M	P/F	M	M	M

5.2.4.5 Information field

The information field of an SREJ shall be as defined in clause 5.2.14.2, an XID shall be as defined in clause 5.3.2, and all other frames shall be as defined in ISO/IEC 13239 [7].

5.2.5 Transmit queues management

Each DLE maintains two transmit queues: the DLE-transmission queue and the DLE-retransmission queue. A frame to be transmitted is queued in the transmission queue. In this queue the frame waits for selection to be transmitted by the MAC sublayer in an AV2M-UNITDATA request. While waiting for authorization to transmit, the DLS sublayer shall update the DLE-transmission and DLE-retransmission queue, eliminating certain frames as specified in clauses 5.2.14.1.1 through 5.2.14.1.8. If all of the frames in the DLE-transmission queue are eliminated, then the authorizations to transmit shall be ignored.

When the AV2M-status indication with values "authorized to transmit" is received from the MAC sublayer after the AV2M-UNITDATA request carrying an AVLC frame has been issued, this AVLC frame is de-queued from DLE-transmission queue. If it is a supervisory and unnumbered frame (XID, FRMR, TEST, DISC, DM, RR, SREJ), INFO, RR (P=1), SREJ (P=1), or FRMR frame, or more generally a frame which requires a response or acknowledgement from the peer DLE, then the AVLC frame is hereafter queued in the DLE-retransmission queues. When queued in the DLE-retransmission queue, a frame aging timer AVLC-frame-A-timer is started, which indicates the time during which the frame has been queued in the DLE-retransmission queue.

When queued for the first time in the DLE-transmission queue, a frame retransmission counter AVLC-frame-retrans-counter is created and set at 0. Each time the frame is queued in the DLE-retransmission queue the AVLC-frame-retrans-counter is incremented by one.

A frame in the DLE-retransmission queue is de-queued when it receives the corresponding response from the peer DLE.

5.2.6 Data link service system parameters

These parameters needed by the DLS sublayer shall be as listed in table 5.6 and as detailed in clauses 5.2.6.1 through 5.2.6.7. DLS parameters shall be set using XID frames.

Table 5.6: Data link service systems parameters

Symbol	Parameter name		Minimum	Maximum	Mode 2 default	Increment
T1min	Delay before retransmission	Minimum	0 s	20 s	1,0 s	1 ms
T1max		Maximum	1 s	20 s	15 s	1 ms
T1mult		Multiplier	1	2,5	1,45	0,01
T1exp		Exponent	1	2,5	1,7	0,01
T2	Delay before ACK		25 ms	10 s	500 ms	1 ms
T3min	Link Initialization Time	Minimum	5 s	25 s	6 s	1 ms
T3max		Maximum	1 s	20 s	15 s	1 ms
T3mult		Multiplier	1	2,5	1,45	0,01
T3exp		Exponent	1	2,5	1,7	0,01
T4	Max delay between transmissions	Aircraft	10 min	1 440 min	20 min	1 min
		Ground	12 min	1 442 min	22 min	1 min
N1	Maximum number of bits in any frame		1 144 bits	16 504 bits	8 312 bits	1 bit
N2	Maximum number of transmissions		1	15	6	1
K	Window Size		1 frame	7 frames	4 frames	1 frame

5.2.6.1 Parameter T1 (delay before non acknowledged retransmission)

Parameter T1 is the time that a DLE will wait for an acknowledgment before retransmitting an INFO, RR (P=1), SREJ (P=1) or FRMR frame. The value of Timer T1 shall be computed by the following formula:

$$\text{Timer T1} = T1_{\min} + 2TD_{99} + \min(U(x), T1_{\max})$$

where:

U(x) is a uniform random number generated between 0 and x;

x = $T1_{\text{mult}} \times TD \times T1_{\text{exp}}^{\text{retrans}}$

TD₉₉ = $(TM1 \times M1)/(1-u)$

and is the running estimate for the 99th percentile transmission delay (between the time at which the frame is sent to the MAC sublayer and the time at which its transmission is completed);

- u** is a measurement of channel utilization with a range of value from 0 to 1, with 1 corresponding to a channel that is 100 percent occupied;
- retrans** is the largest retransmission count of all the outstanding frames, i.e. the maximum value of the AVLC-frame-retrans-counter of all frames in the DLE-transmission and DLE-retransmission queues.

5.2.6.2 Parameter T2 (delay before acknowledgment)

Parameter T2 defines the maximum time allowed for the DLE to respond to any received frame (other than an XID) in order to ensure the response is received before the peer DLE's DLE-T1-timer expires.

A station shall respond to any received frame (other than an XID) within parameter T2 time in order to ensure the response is received before the peer DLE's DLE-T1-timer expires.

The period T2 should be less than the T1min value of the peer DLE. It will permit the acknowledging DLE to schedule the response as an event in normal data processing. It will also allow sufficient time for an acknowledgment while maximizing the likelihood that an INFO frame will be transmitted and eliminate the need for an explicit acknowledgment.

5.2.6.3 Parameter T3 (link initialization time)

Parameter T3 shall be set to the time that a DLE waits for an XID response before retransmitting an exchange identification command (XID_CMD).

The value of parameter T3 shall be computed using the following formula:

$$\text{Timer T3} = T3_{\min} + 2TD_{99} + \min(U(y), T3_{\max})$$

$$y = T3_{\text{mult}} \times TD \times T3_{\text{exp}}^{\text{retrans}}$$

T3min shall be greater than T1min to allow the responding entity time to co-ordinate the response and perform any additional initialization processing.

5.2.6.4 Parameter T4 (maximum delay between transmissions)

Parameter T4 shall be set to the maximum delay between transmissions (T4). The value of parameter T4 shall be at least two minutes longer for a ground DLE than for the peer aircraft DLE.

5.2.6.4.1 Recommendation

A DLE in the ABM or SRM should send any outstanding frames with the P bit of the last INFO frame set to 1.

5.2.6.5 Parameter N1 (maximum number of bits of any frame)

The parameter N1 defines the maximum number of bits in any frame (excluding flags and zero bits inserted for transparency) that a DLS shall accept.

5.2.6.6 Counter N2 (maximum number of transmissions)

Counter N2 defines the maximum number of times that the DLS shall attempt to transmit any outstanding XID_CMD frame. Counter N2 shall be set to zero when a new frame is ready for transmission. Counter N2 shall be incremented after each transmission of the frame. The counter shall be cleared after its associated frame is acknowledged.

When DLE-T1-timer expires, a DLE shall invoke the retransmission procedures of clause 5.2.6.1 up to N2 - 1 times.

When DLE-T3-timer expires, a DLE shall invoke the retransmission procedures of clause 5.2.6.1 up to N2 - 1 times.

When Counter N2 reaches the maximum number of attempts (value of parameter N2) the LME shall be informed and the frame shall not be transmitted.

There is one Counter N2 per unacknowledged frame. The value of the ground N2 parameter may be different from the value of the aircraft N2 parameter.

5.2.6.7 Parameter k (window size)

Parameter k shall be set to the maximum number of outstanding sequentially numbered INFO frames that may be transmitted before an acknowledgment is required.

The value of the ground k parameter may be different from the value of the aircraft k parameter.

5.2.7 DLE retransmission timers

Each DLE shall manage one DLE-T1-timer for other than XID frame retransmission, one DLE-T3-timer for XID-CMD frame retransmission and one DLE-T4-timer for link monitoring.

5.2.8 Description of procedures

Except as noted in this clause and in clauses 5.2.9 through 5.2.14, the standard procedures described in ISO/IEC 13239 [7] shall be followed.

5.2.8.1 Procedure retransmission schedule

5.2.8.1.1 Purpose

To schedule retransmission of frames.

5.2.8.1.2 Use

When any frame is queued in the DLE-retransmission queue or on receipt of an acknowledgement or a response.

5.2.8.1.3 Procedure

All frames which have their AVLC-frame-counter equal to N2 are de-queued from the DLE-retransmission queue and the LME shall be informed that these frames are not transmitted.

If DLE-T1-timer is not running and if INFO, RR (P=1), SREJ (P=1), or FRMR frames exist in the DLE-retransmission queue, then DLE-T1-Timer shall be started with current value of T1.

If DLE-T3-timer is not running and if a XID_CMD exchange identification command frame exists in the DLE-retransmission queue, then DLE-T3-timer shall be started with current value of T3.

If an INFO, RR (P=1), SREJ (P=1), or FRMR frame is acknowledged, the frame shall be discarded. If there are still INFO, RR (P=1), SREJ (P=1), or FRMR frames in the DLE-retransmission queue, then DLE-T1-timer shall be re-started at time $T1 - T_m$, where T_m is the largest value of AVLC-frame-A-timer of the INFO, RR (P=1), SREJ (P=1), or FRMR frames queued in the DLE-retransmission queue.

If a response to an XID_CMD is received, then all XID_CMDs in the retransmission queue are de-queued and DLE-T3-timer shall be cancelled.

5.2.8.2 Procedure frame retransmission

5.2.8.2.1 Purpose

To retransmit outstanding frames.

5.2.8.2.2 Use

Upon expiration of DLE-T1-timer.

5.2.8.2.3 Procedure

All INFO, RR (P=1), SREJ (P=1), or FRMR frames in the DLE-retransmission queue that have their AVLC-frame-A-timer greater than $T1_{min} + 2TD$ shall be de-queued, and queued in the DLE-transmission queue.

5.2.8.3 Procedure XID frame retransmission

5.2.8.3.1 Purpose

To retransmit outstanding XID frames.

5.2.8.3.2 Use

Upon expiration of DLE-T3-timer.

5.2.8.3.3 Procedure

All XID_CMDs frames (except for ground station information frames) in the DLE-retransmission queue that have their AVLC-frame-A-timer greater than $T1_{min} + 2TD$ shall be de-queued, and queued in the DLE-transmission queue.

5.2.8.4 Procedure link monitoring

5.2.8.4.1 Purpose

To verify the continued existence of the link between a DLE and its peer DLE.

5.2.8.4.2 Use

When a frame is queued in the transmission queue.

5.2.8.4.3 Procedure

DLE-T4-timer shall be started or restarted with time T4. DLE-T4-timer shall never be cancelled.

5.2.8.5 Procedure link recovery

5.2.8.5.1 Purpose

To recover outdated link.

5.2.8.5.2 Use

On DLE-T4-timer expiration.

5.2.8.5.3 Procedure

Upon expiration of DLE-T4-timer, DLE shall queue in DLE-transmission queue a command frame (P=1) to ensure a response from the peer DLE. When in the ABM, the DLE shall send an RR; when in the SRM, the DLE shall send an SREJ; when in the FRM, the DLE shall send a FRMR. The command frame shall be transmitted using normal DLE-T1-Timer procedures up to N2 times. If no response is received, the DLE shall assume that the link is disconnected and that site recovery procedures shall be invoked.

NOTE 1: DLE-T4-timer is used to verify the continued existence of the link.

NOTE 2: There is one DLE-T4-timer per DLE.

5.2.9 Modes of operation

The only modes of operation that a DLE shall support are those detailed below.

5.2.9.1 Operational mode

The operational mode shall be Asynchronous Balanced Mode (ABM).

5.2.9.2 Non-operational mode

The non-operational mode shall be Asynchronous Disconnected Mode (ADM).

NOTE: A DLE or LME may enter non-operational mode as a result of issuing or receiving any of the following frames: DISC, XID_CMD_LCR, DM or XID_RSP_LCR (abbreviated frame names are defined in tables 5.4 and 5.12).

5.2.9.2.1 DISC frame

If a DLE is unable to continue to receive, it shall transmit a DISC to terminate the current link. The P bit shall be set to 0 in DISC commands. A DLE shall treat all received DISCs (regardless of the P bit) as a DISC (P=0).

NOTE: The use of a DISC command may result in the loss of unacknowledged data.

5.2.9.2.2 DM frame

If a DLS receives any valid unicast frame, except for an XID or TEST frame, from a DLS with which it does not have a link, it shall respond with a DM frame. All DM frames shall be transmitted with the F bit set to 0.

An aircraft transmitting or receiving a DM frame shall initiate link establishment on one LME if no links remain. A DLE shall treat all received DMs (regardless of the F bit) as a DM (F=0).

NOTE 1: If an LME is in the process of executing handoff, it will retransmit the XID_CMD_HO (P=1) and wait for timer T3 to expire.

NOTE 2: A station receiving an invalid frame may choose to discard the frame instead of responding with a DM.

NOTE 3: The procedures for an LME receiving a unicast XID from an LME with which it does not have a link are found in clause 5.3.5.

5.2.9.3 Frame reject mode

When in ABM or SRM, and after transmitting a FRMR command, the DLE shall enter the Frame Reject Mode (FRM). The DLE shall re-enter the ABM only after it receives a UA (F=1) frame.

5.2.9.4 Sent selective reject mode

When in ABM, and after transmitting an SREJ, the DLE shall enter the Sent selective Reject Mode (SRM). The DLE shall re-enter the ABM only after it receives the missing INFO frames.

5.2.10 Use of the P/F bit

The use of the P/F bit shall follow the procedures detailed in ISO/IEC 13239 [7], except as modified by clauses 5.2.9.1 through 5.2.9.4.

5.2.10.1 General

When a DLE receives a command frame with the P bit set to 1, the F bit shall be set to 1 in the corresponding response frame. The C/R bit in the address field shall be referenced to resolve the ambiguity between command and response frames.

5.2.10.2 INFO frames

After receiving an INFO frame, a DLE shall generate an acknowledgment within T2 seconds after detecting the end of transmission. If a valid INFO (P=1) is received, the response shall be either an RR (F=1) or SREJ (F=1). If a valid INFO (P=0) is received, the response shall be either an RR (F=0) or SREJ (F=0).

5.2.10.3 Recommendation

The only time that an RR or SREJ frame should be transmitted with P=1 is when T4 expires. The only time that an INFO frame should be transmitted with P=1 is either when T4 expires or the transmit window has closed.

5.2.10.4 Unnumbered frames

The P bit shall be set to 0 for UI and DISC frames. The F bit shall be set to 0 for DM frames. Therefore a response (e.g. UA) shall not be expected, and if received it shall be treated as an error.

5.2.11 Unnumbered command frame collisions

When a command frame collision occurs, the entity which has precedence shall discard the received frame from its peer entity and the peer entity shall respond as if it had never sent its command frame.

5.2.11.1 DLE procedures

While waiting for a response to an unnumbered command frame (i.e. an FRMR), a DLE whose DLS address is lower than its peer DLE shall have precedence.

5.2.11.2 LME procedures

An LME receiving a Broadcast Handoff shall process it regardless of what `XID_CMD` it is waiting for. Otherwise, an LME sending an `XID_CMD` (P=1) shall have precedence over an LME sending an `XID_CMD` (P=0). Otherwise, an LME whose DLS address is lower than its peer LME shall have precedence.

5.2.12 XID frame

The XID frame shall be used for the LME to establish and maintain links as defined in clause 3.4. The originator of an `XID_CMD` (P=1) frame shall retransmit the XID upon expiration of Timer T3 whenever no response has been received. The receiving LME shall use the XID sequence number and retransmission field to differentiate a retransmission from a new XID; however, no meaning shall be attached to a missing sequence number. An LME shall send the exact same `XID_RSP` to every retransmission of an `XID_CMD`, unless it intends to change the link status via an `XID_CMD` (`_HO`, or `_LCR`).

5.2.13 Broadcast

Only `XID_CMD`s or UIs shall be broadcast. The P bit shall be set to 0 (no acknowledgment) for broadcast frames.

5.2.14 Information transfer

Except as noted below, the procedures for information transfer shall be specified by ISO/IEC 13239 [7].

5.2.14.1 Void

5.2.14.1.1 Eliminate redundant frames

At most one RR, SREJ, DM, FRMR, or retransmitted INFO (of a given sequence number) shall be queued in response to a transmission.

5.2.14.1.2 Recommendation

To eliminate redundant frames, superseded frames in the transmit queues should be deleted (e.g. an INFO queued in response to a T1 timeout and then an SREJ).

5.2.14.1.3 Recommendation

If any INFO frame is received from a peer DLE, the DLS sublayer should update the N(r) of all numbered frames addressed to that DLE in the transmit queues, thus improving the probability of the acknowledgment arriving.

5.2.14.1.4 Recommendation

To eliminate unnecessary retransmissions, if any numbered frame is received from a peer DLE, all frames in the transmit queue that it acknowledges should be deleted. If an XID_CMD from a peer LME with a lower DLS address or an XID_RSP is received from a peer LME, any XID_CMDs in the transmit queue for that LME should be deleted.

5.2.14.1.5 Procedures for transmission

Supervisory frames have higher priority than the information frames, and so supervisory and unnumbered (XID, FRMR, TEST, DISC, DM) frames shall be transmitted in preference to information frames.

5.2.14.1.6 Recommendation

On transmission of an INFO frame, the DLE should also transmit any RR frame in the transmission queue so as to avoid transmitting the RR as a separate frame.

5.2.14.1.7 Recommendation

A station receiving a FRMR, DISC, or DM frame should delete all outstanding traffic for the transmitting DLE, as it would not be accepted if transmitted.

5.2.14.1.8 Recommendation

All unicast frames in the transmit queues should be deleted after the radio supporting this transmit queue is returned, as the intended station cannot receive the transmission.

5.2.14.2 SREJ frame

The multi-selective reject option in ISO/IEC 13239 [7] shall be used to request the retransmission of more than one INFO frame. The SREJ (F=0) frame shall be generated and queued in the transmission queue only after receipt of an out-of-order INFO (P=0). The SREJ (F=1) shall be generated only after receipt of an INFO (P=1), RR (P=1), or SREJ (P=1). The SREJ (P=1) frame shall be generated only in accordance with the procedures of clauses 5.2.6.4 and 5.2.8.4. A DLE shall acknowledge those frames which were received correctly but out of order by including in the SREJ information field an octet with bits 6-8 set to the INFO frame's sequence number and bit 1 set to 1. Although the F bit may be set to 0, the SREJ frame shall always acknowledge INFO frames up to N(r)-1 (where N(r) is the value in the control field).

NOTE: AVLC has extended the standard ISO/IEC 13239 [7] SREJ functionality to selectively acknowledge frames. In ISO/IEC 13239 [7], the octets in the information field which were requesting retransmission of frames had bit position 1 set by default to 0.

5.2.14.3 FRMR frame

If a DLE receives an illegal frame (as defined by ISO/IEC 13239 [7]), it shall transmit a FRMR (P=1) to reset the link (e.g. state variables, timers, and queues). A DLE, on receiving or transmitting a UA (F=1), shall reset the link (no XID exchange required). A DLE shall use the normal T1 and N2 procedures during the FRMR/UA exchange. A DLE transmitting the FRMR shall also retransmit the FRMR either upon expiration of DLE-T4-Timer or upon receipt of any frame other than a UA (F=1). A DLE receiving an illegal FRMR shall either discard the frame or treat it as a valid FRMR.

5.2.14.4 UA frame

The UA frame shall be used only to acknowledge a FRMR.

5.2.14.5 UI frame

UI frames shall be used solely to support connectionless data transfer required to provide broadcast services.

5.2.14.6 TEST frame

NOTE: The TEST command/response exchange has been included in AVLC to allow a station to perform a loopback test using logic that is isolated from the normal frame processing.

5.3 VDL management entity

5.3.1 Services

The services of the VME shall be as follows:

- a) link provision; and
- b) link change notifications.

5.3.1.1 Link provision

A VME shall have an LME for each peer LME. Hence, a ground VME shall have an LME per aircraft and an aircraft VME shall have an LME per ground system. An LME shall establish a link between a local DLE and a remote DLE associated with its peer LME. A ground LME shall determine if an aircraft station is associated with its peer aircraft LME by comparing the aircraft address; two aircraft stations with identical aircraft addresses are associated with the same LME. An aircraft LME shall determine if a ground station is associated with its peer ground LME by bit-wise logical ANDing the DLS address with the station ground system mask provided by the peer ground LME; two ground stations with identical masked DLS addresses are associated with the same LME.

Each aircraft and ground LME shall monitor all transmissions from its peer's stations to maintain a reliable link between some ground station and the aircraft while the aircraft is in coverage of an acceptable ground station in the ground system.

NOTE: If an aircraft receives a frame from a ground station, only one LME will process and react to that frame. Thus the qualifying phrase "from a ground station associated with its peer LME" will not be included and should be understood to be implied.

5.3.1.2 Link change notifications

The VME shall notify the intermediate-system system management entity (IS-SME) of changes in link connectivity supplying information contained in the XID frames received.

5.3.2 Exchange identity (XID) parameter

In the tables included in the following clauses, the following order is implied:

- a) bit order in each parameter value shall be indicated by subscript numbers. Bit 1 shall indicate the least significant bit; and
- b) bits shall be transmitted octet by octet, starting with the parameter id, and within each octet the rightmost bit (as shown in the tables) shall be transmitted first.

The tables are divided into three major columns that define the field name, the bit encoding and brief explanatory notes.

Requirements for the use of the parameters defined in the following clauses are defined in clause 5.3.5.

5.3.2.1 Encoding

The XID information field shall be encoded per ISO/IEC 13239 [7] and may include the parameters described in clauses 5.3.2.2.1 to 5.3.2.7.

5.3.2.2 Public parameters

XID parameters shall be encoded as defined in ISO/IEC 13239 [7], with the addition of the private parameter data link layer subfield as defined in ISO/IEC 13239 [7]. The format identifier (hexadecimal 82) shall be used (per ISO/IEC 13239 [7], annex C) to identify the public parameter list identified in ISO/IEC 13239 [7]. The VDL shall use the public parameter group ID of hexadecimal 80 to negotiate the common HDLC parameters. The public parameter set ID shall be included in XID frames if other public parameters are included; the public parameter set ID shall not be included in XID frames if other public parameters are not included.

NOTE: ISO/IEC 13239 [7] defines certain public parameters as receive and transmit which are referred to herein as uplink and downlink respectively.

5.3.2.2.1 HDLC public parameter set identifier

The HDLC parameter set shall be identified by the ISO/IEC 13239 [7] IA5 character string encoded as per table 5.7. This parameter shall be included whenever any of the public parameters are sent. It shall be the first public parameter sent as per ISO/IEC 13239 [7].

Table 5.7: HDLC public parameter set identifier

Parameter ID	0	0	0	0	0	0	0	0	0	HDLC public parameter set
Parameter length	0	0	0	0	1	0	0	1		
Parameter value	0	0	1	1	1	0	0	0		character '8'
	0	0	1	1	1	0	0	0		character '8'
	0	0	L	l	1	0	0	0		character '8'
	0	0	1	1	0	1	0	1		character '5'
	0	0	1	1	1	0	1	0		character ':'
	0	0	1	1	0	0	0	1		character '1'
	0	0	1	1	1	0	0	1		character '9'
	0	0	1	1	1	0	0	1		character '9'
	0	0	1	1	0	0	1	1		character '3'

5.3.2.2.2 Timer T1 parameter

This parameter defines the value of the downlink Timer T1 that an aircraft DLE shall use. The values shall be defined in units of milliseconds for T1min and T1max and in hundredths for T1mult and T1exp. The timer values shall be encoded as 4 unsigned 16-bit integers as per table 5.8.

Table 5.8: Timer T1 parameter

Parameter ID	0	0	0	0		1	0	0	1	Timer T1downlink
Parameter length	0	0	0	0		1	0	0	0	
Parameter value	l_{16}	l_{15}	l_{14}	l_{13}		l_{12}	l_{11}	l_{10}	l_9	(T1 min)
	l_8	l_7	l_6	l_5		l_4	l_3	l_2	l_1	
	u_{16}	u_{15}	u_{14}	u_{13}		u_{12}	u_{11}	u_{10}	u_9	(T1max)
	u_8	u_7	u_6	u_5		u_4	u_3	u_2	u_1	
	m_{16}	m_{15}	m_{14}	m_{13}		m_{12}	m_{11}	m_{10}	m_9	(T1mult)
	m_8	m_7	m_6	m_5		m_4	m_3	m_2	m_1	
	e_{16}	e_{15}	e_{14}	e_{13}		e_{12}	e_{11}	e_{10}	e_9	(T1exp)
	e_8	e_7	e_6	e_5		e_4	e_3	e_2	e_1	

5.3.2.3 VDL private parameters

The parameter identifier field shall allow simple identification of the purpose of the parameter as defined in table 5.9.

Table 5.9: VDL private parameters

Bit 8	Bit 7	Purpose
0	0	General purpose information private parameter
0	1	Ground-initiated modification private parameter
1	0	Aircraft-initiated information private parameter
1	1	Ground-initiated information private parameter
NOTE: ISO/IEC 13239 [7] defines the group identifier of the private parameter function to be the hexadecimal value F0.		

5.3.2.4 General purpose information private parameters

Both aircraft and ground-based LMEs shall use general purpose information private parameters to transfer basic information to each other.

5.3.2.4.1 VDL private parameter set identifier

The VDL private parameter set identifier shall be the ISO IA5 character capital "V" encoded as per table 5.7. This parameter shall be included whenever any of the private parameters are sent. It shall be the first private parameter sent as per ISO/IEC 13239 [7].

Table 5.10a: Parameter set identification

Parameter ID	0	0	0	0		0	0	0	0	Parameter set identification
Parameter length	0	0	0	0		0	0	0	1	
Parameter value	0	1	0	1		0	1	1	0	Character V

5.3.2.4.2 Connection management parameter

This parameter defines the type of XID sent and the connection options negotiated for that particular link. It shall be used in XID frames sent during link establishment and ground-based initiated ground station handoff and shall be encoded as per tables 5.10b, 5.11 and 5.12. An LME shall set the reserved bits to 0 on transmission, and shall ignore the value of these bits on receipt.

Table 5.10b: Connection management parameter

Parameter ID	0	0	0	0		0	0	0	1	Connection management
Parameter length	n ₈	n ₇	n ₆	n ₅		n ₄	n ₃	n ₂	n ₁	
Parameter value	0	0	0	0		v	X	r	h	
NOTE: The value in the parameter length field is variable to allow for the possibility of additional options.										

Table 5.11: Connection management parameter values

Bit	Name	Encoding	
1	H	h=0	No link currently established
		H=1	Link currently established
2	R	r=0	Link connection accepted
		r=1	Link connection refused
3	X	X=0	Only VDL-specific ground DTE addresses
		X=1	Ground network DTE addresses accepted
4	V	V=0	Expedited subnetwork connection not supported
		V=1	Expedited subnetwork connection supported
5-8	Reserved	Set to 0	

Table 5.12: Abbreviated XID names

Name	C/R	P/F	h	r	x	V	Notes
GSIF	0	0	-	-	-	-	Ground Station Identification Frame
XID_CMD_LE	0	1	0	0	x	x	Link Establishment
XID_CMD_LCR	0	0	0	1	x	x	Link Connection Refused
XID_CMD_LPM	0	1	-	-	-	-	Link Parameter Modification
XID_CMD_HO	0	1	1	0	x	x	If P=1, then Initiating Handoff
XID_CMD_HO	0	0	1	0	x	x	If broadcast and P=0, then commanding a Broadcast Handoff. If unicast and P=0, then Requesting Handoff
XID_RSP_LE	1	1	0	0	x	x	
XID_RSP_LCR	1	1	0	1	x	x	
XID_RSP_LPM	1	1	-	-	-	-	
XID_RSP_HO	1	1	1	0	x	x	
"x" = do not care case. "- " = connection management parameter not included.							

5.3.2.4.3 Signal Quality Parameter (SQP)

This parameter defines the received signal quality value of the last received transmission from the destination of the XID. It shall be encoded as a 4-bit integer as per table 5.13.

Table 5.13: Signal quality parameter

Parameter ID	0	0	0	0		0	0	1	0	SQP
Parameter length	0	0	0	0		0	0	0	1	
Parameter value	0	0	0	0		q ₄	q ₃	q ₂	q ₁	

The contents of the SQP value field (q bits) are as defined in clause 5.

If the transmitting LME included the SQP parameter in the XID_CMD (P=1) frame, then the responding LME shall also include it in the respective XID_RSP (F=1) frame.

NOTE: This parameter will be used for testing purposes.

5.3.2.4.4 XID sequencing parameter

This parameter defines the XID sequence number (sss) and an XID retransmission number (rrrr). It shall be encoded as per table 5.14. An LME shall increment the sequence number for every new XID (setting the retransmission field to 0 on the first transmission) and shall increment the retransmission field after every retransmission. In an XID_RSP, the sequence number shall be set to the value of the XID_CMD sequence number generating the response (the retransmission field shall be ignored).

Table 5.14: XID sequencing parameter

Parameter ID	0	0	0	0		0	0	1	1	XID sequencing
Parameter length	0	0	0	0		0	0	0	1	
Parameter value	r_4	r_3	r_2	r_1		0	s_3	s_2	s_1	

5.3.2.4.5 AVLC specific options parameter

This parameter defines which AVLC protocol options are supported by the transmitting station. It shall be encoded as per tables 5.15 and 5.16. An LME shall set the reserved bits to 0 on transmission, and shall ignore the value of these bits on receipt. When both this parameter and the Connection Management parameter are included in an XID, the bit values for those options, which are included in both parameters, shall be determined by the Connection Management parameter.

Table 5.15: AVLC specific options parameter

Parameter ID	0	0	0	0		0	1	0	0	AVLC specific options
Parameter length	n_8	n_7	n_6	n_5		n_4	n_3	n_2	n_1	
Parameter value	0	0	0	b_s		b_l	l	v	x	
NOTE:	The value in the parameter length field is variable to allow for the possibility of additional options.									

Table 5.16: AVLC specific option values

Bit	Name	Encoding	
		Value	Description
1	X	x=0	Only VDL-specific DTE addresses
		x=1	Ground network DTE addresses accepted
2	V	V=0	Expedited subnetwork connection not supported
		V=1	Expedited subnetwork connection supported
3	I	I=0	Does not support Initiated Handoff
		I=1	Supports Initiated Handoff
4	b_l	$b_l=0$	Broadcast link handoff not supported
		$b_l=1$	Broadcast link handoff supported
5	b_s	$b_s=0$	Broadcast subnetwork connection not supported
		$b_s=1$	Broadcast subnetwork connection supported (b_l shall also be 1)
6-8	Reserved	Set to 0	

5.3.2.4.6 Expedited subnetwork connection parameter

This parameter defines the expedited packets that the current XID contains. This parameter, which may be repeated, shall contain one and only one of the following subnetwork packets: CALL REQUEST, CALL CONFIRMATION, or a CLEAR REQUEST. It shall be encoded as table 5.17. The inclusion of this parameter shall invoke the expedited subnetwork connection procedures. This parameter shall only be included if the ground LME indicates that it supports expediting subnetwork connections. If, during link establishment, an aircraft LME has not received a ground station information frame (GSIF), it may assume expedited subnetwork connection is supported.

Table 5.17: Expedited subnetwork connection parameter

Parameter ID	0	0	0	0		0	1	0	1	Expedited SN connection
Parameter length	n_8	n_7	n_6	n_5		n_4	n_3	n_2	n_1	
Parameter value	p_8	p_7	p_6	p_5		p_4	p_3	p_2	p_1	an ISO/IEC 8208 [5] octet

5.3.2.4.7 LCR cause parameter

This parameter defines the reason why the link connection request was refused. The parameter, which may be repeated, shall consist of a rejection cause code (c bits), backoff delay time in seconds (d bits), and any additional data required by the various parameters. It is encoded as per table 5.18.

Cause codes 00 hex to 7F hex shall apply to the responding station; cause codes 80 hex to FF hex shall apply to the responding system and shall be encoded as per table 5.19.

At least one copy of this parameter shall be included whenever the "r" bit in the Connection Management parameter is set to 1; this parameter shall not be included if the "r" bit is set to 0. An LME receiving an LCR Cause parameter less than 80 hex shall not transmit another XID_CMD to that peer *station* for the duration of time designated in the LCR Cause parameter. An LME receiving an LCR Cause parameter greater than 7F hex shall not transmit another XID_CMD to that peer *system* for the duration of time designated in the LCR Cause parameter.

NOTE: An aircraft LME receiving a station-based cause code from one ground station may immediately transmit the same XID_CMD to another ground station of the same ground system.

Table 5.18: LCR cause parameter

Parameter ID	0	0	0	0		0	1	1	0	LCR Cause
Parameter length	n_8	n_7	n_6	n_5		n_4	n_3	n_2	n_1	
Parameter value	c_8	c_7	c_6	c_5		c_4	c_3	c_2	c_1	cause
	d_{16}	d_{15}	d_{14}	d_{13}		d_{12}	d_{11}	d_{10}	d_9	delay
	d_8	d_7	d_6	d_5		d_4	d_3	d_2	d_1	
	a_8	a_7	a_6	a_5		a_4	a_3	a_2	a_1	additional data

Table 5.19: Cause code table

Cause	Function	Additional Data Encoding							
00h	Bad local parameter. The additional data block, which may be repeated, contains the GI and PI of a parameter which cannot be satisfied by this ground station. This cause will not be sent for an illegal Connection Management parameter.	G_8	G_7	G_6	G_5	G_4	G_3	G_2	G_1
		P_8	P_7	P_6	P_5	P_4	P_3	P_2	P_1
01h	Out of link layer resources.	Undefined							
02h	Out of packet layer resources.								
03h	Terrestrial network not available.								
04h	Terrestrial network congestion.								
05h	Cannot support autotune.								
06h	Station cannot support initiating handoff.								
07-7Eh	Reserved								
7Fh	Other unspecified local reason.								

5.3.2.5.2 Acceptable alternate ground station parameter

This parameter defines a list of ground stations in order of preference. This parameter shall be a list of DLS addresses encoded in 32-bit fields as per table 5.22. These shall be used by the ground LME during handoffs as possible alternate ground stations, if the proposed ground station is not acceptable to the ground LME.

Table 5.22: Acceptable alternative ground station parameter

Parameter ID	1	0	0	0		0	0	1	0	Alternate ground station
Parameter length	n_8	n_7	n_6	n_5		n_4	n_3	n_2	n_1	
Parameter value	g_{22}	g_{23}	g_{24}	g_{25}		g_{26}	g_{27}	0	0	DLS Address
	g_{15}	g_{16}	g_{17}	g_{18}		g_{19}	g_{20}	g_{21}	0	
	g_8	g_9	g_{10}	g_{11}		g_{12}	g_{13}	g_{14}	0	
	g_1	g_2	g_3	g_4		g_5	g_6	g_7	0	

5.3.2.5.3 Destination airport parameter

This parameter defines the aircrafts destination airport identifier. It shall be encoded as four 8-bit ISO IA5 characters per table 5.23.

Table 5.23: Destination airport parameter

Parameter ID	1	0	0	0		0	0	1	1	Destination airport
Parameter length	n_8	n_7	n_6	n_5		n_4	n_3	n_2	n_1	
Parameter value	a_8	a_7	a_6	a_5		a_4	a_3	a_2	a_1	(first character)
	b_8	b_7	b_6	b_5		b_4	b_3	b_2	b_1	
	c_8	c_7	c_6	c_5		c_4	c_3	c_2	c_1	
	d_8	d_7	d_6	d_5		d_4	d_3	d_2	d_1	(fourth character)

5.3.2.5.4 Aircraft location parameter

This parameter defines the current position of the aircraft. It shall be encoded as shown in tables 5.24 and 5.25.

Table 5.24: Aircraft Location parameter

Parameter ID	1	0	0	0		0	1	0	0	Aircraft location
Parameter length	0	0	0	0		0	1	0	0	
Parameter value	v_{12}	v_{11}	v_{10}	v_9		v_8	v_7	v_6	v_5	latitude (v)
	v_4	v_3	v_2	v_1		h_{12}	h_{11}	h_{10}	h_9	longitude (h)
	h_8	h_7	h_6	h_5		h_4	h_3	h_2	h_1	
	a_8	a_7	a_6	a_5		a_4	a_3	a_2	a_1	altitude (a)

Table 5.25: Aircraft location subfield description

Subfield	Range	Encoding	Notes	Abbreviation
latitude	+90 to -90	Integer [degrees × 10]	positive = north, negative = south, coded as two's complement	v bits
longitude	+180 to -180	Integer [degrees × 10]	positive = east, negative = west, coded as two's complement	h bits
Altitude	0 to 2 550	Integer [FL/10]	use 0 for < 999 feet, 255 for ≥ 255 000 feet	a bits
NOTE:	For example, 100 degrees 18 minutes west equals 100,3 degrees west, which is expressed as -1003, which is encoded as C15 hexadecimal.			

5.3.2.6 Ground-based initiated modification private parameters

A ground LME shall use the ground-based initiated modification parameters to change the value of various parameters in one or more aircraft. Aircraft LMEs shall not send an XID with these parameters.

5.3.2.6.1 Autotune frequency parameter

This parameter defines the frequency and modulation scheme that an aircraft LME shall use to reply to a ground station listed in the replacement ground station parameter. This parameter shall be sent by a ground LME when an autotune is required. The parameter shall be encoded as a 16-bit field as per table 5.26. The modulation subfield (m bits) shall be defined as per table 5.21. The frequency subfield (f bits) shall be the frequency encoded as:

$$\text{Integer } [(\text{frequency in MHz} \times 100) - 10\,000].$$

NOTE: As an example, for a frequency of 131,725 MHz, the encoded value is decimal 3 172 or hexadecimal C64.

Table 5.26: Autotune frequency parameter

Parameter ID	0	1	0	0	0	0	0	0	0	Autotune frequency
Parameter length	0	0	0	0	0	0	1	0		
Parameter value	m ₄	m ₃	m ₂	m ₁	f ₁₂	f ₁₁	f ₁₀	f ₉		
	f ₈	f ₇	f ₆	f ₅	f ₄	f ₃	f ₂	f ₁		

5.3.2.6.2 Replacement ground station list

This parameter defines a list of ground stations in order of ground LME preference. This parameter shall be encoded as a list of DLS addresses in 32-bit fields as per table 5.27. The aircraft LME shall use these addresses during handoffs as possible alternate ground stations if the proposed ground station is not acceptable to the LME.

Table 5.27: Replacement ground station list

Parameter ID	0	1	0	0	0	0	0	1	Replacement ground station list
Parameter length	n ₈	n ₇	n ₆	n ₅	n ₄	n ₃	n ₂	n ₁	
Parameter value	g ₂₂	g ₂₃	g ₂₄	g ₂₅	g ₂₆	g ₂₇	0	0	
	g ₁₅	g ₁₆	g ₁₇	g ₁₈	g ₁₉	g ₂₀	g ₂₁	0	
	g ₈	g ₉	g ₁₀	g ₁₁	g ₁₂	g ₁₃	g ₁₄	0	
	g ₁	g ₂	g ₃	g ₄	g ₅	g ₆	g ₇	0	

5.3.2.6.3 Timer T4 parameter

This parameter defines the value of Timer T4 (in minutes) that the aircraft DLEs shall use. It shall be encoded as an unsigned 16-bit integer as per table 5.28.

Table 5.28: Timer T4 parameter

Parameter ID	0	1	0	0	0	0	1	0	Timer T4
Parameter length	0	0	0	0	0	0	1	0	
Parameter value	n ₁₆	n ₁₅	n ₁₄	n ₁₃	n ₁₂	n ₁₁	n ₁₀	n ₉	
	n ₈	n ₇	n ₆	n ₅	n ₄	n ₃	n ₂	n ₁	

5.3.2.6.4 MAC persistence parameter

This parameter defines the value of the parameter p in the p-persistent CSMA algorithm that an aircraft MAC shall use. This 8-bit integer shall be encoded as hexadecimal 00 (= decimal 1/256) to hexadecimal FF (= decimal 1) as per table 5.29.

Table 5.29: MAC persistence parameter

Parameter ID	0	1	0	0		0	0	1	1	MAC persistence
Parameter length	0	0	0	0		0	0	0	1	
Parameter value	n_8	n_7	n_6	n_5		n_4	n_3	n_2	n_1	

5.3.2.6.5 Counter M1 parameter

This parameter defines the value of M1 that an aircraft MAC shall use. It shall be encoded as a 16-bit unsigned integer as per table 5.30.

Table 5.30: Counter M1 parameter

Parameter ID	0	1	0	0		0	1	0	0	Counter M1
Parameter length	0	0	0	0		0	0	1	0	
Parameter value	n_{16}	n_{15}	n_{14}	n_{13}		n_{12}	n_{11}	n_{10}	n_9	
	n_8	n_7	n_6	n_5		n_4	n_3	n_2	n_1	

5.3.2.6.6 Timer TM2 parameter

This parameter defines the value of Timer TM2 (in seconds) that an aircraft MAC shall use. It shall be encoded as an 8-bit integer per table 5.31.

Table 5.31: Timer TM2 parameter

Parameter ID	0	1	0	0		0	1	0	1	Timer TM2
Parameter length	0	0	0	0		0	0	0	1	
Parameter value	N_8	n_7	n_6	n_5		n_4	n_3	n_2	n_1	

5.3.2.6.7 Timer TG5 parameter

This parameter defines the value of Timer TG5 (in seconds) that the initiating and responding LMEs shall use. It shall be encoded as two 8-bit integers per table 5.32.

Table 5.32: Timer TG5 parameter

Parameter ID	0	1	0	0		0	1	1	0	Timer TG5
Parameter length	0	0	0	0		0	0	1	0	
Parameter value	i_8	i_7	i_6	i_5		i_4	i_3	i_2	i_1	(initiating)
	r_8	r_7	r_6	r_5		r_4	r_3	r_2	r_1	(responding)

5.3.2.6.8 T3min parameter

This parameter defines the value of T3min (in milliseconds) that an aircraft DLE shall use. It shall be encoded as an unsigned 16 bit integer as per table 5.33.

Table 5.33: T3 min parameter

Parameter ID	0	1	0	0		0	1	1	1	T3min
Parameter length	0	0	0	0		0	0	1	0	
Parameter value	n_{16}	n_{15}	n_{14}	n_{13}		n_{12}	n_{11}	n_{10}	n_9	
	n_8	n_7	n_6	n_5		n_4	n_3	n_2	n_1	

5.3.2.6.9 Ground station address filter parameter

This parameter defines the DLS address of the ground station from which links are handed-off. This parameter shall be sent in an `XID_CMD` and a receiving aircraft LME shall process the `XID_CMD` only if it has a link to the identified ground station. The ground station address filter shall be encoded in a 32-bit field as defined in table 5.34.

Table 5.34: Ground station address filter parameter

Parameter ID	0	1	0	0		1	0	0	0	Ground station address filter
Parameter length	0	0	0	0		0	1	0	0	
Parameter value	g_{22}	g_{23}	g_{24}	g_{25}		g_{26}	g_{27}	0	0	DLS address
	g_{15}	g_{16}	g_{17}	g_{18}		g_{19}	g_{20}	g_{21}	0	
	g_8	g_9	g_{10}	g_{11}		g_{12}	g_{13}	g_{14}	0	
	g_1	g_2	g_3	g_4		g_5	g_6	g_7	0	

5.3.2.6.10 Broadcast connection parameter

This parameter defines a single aircraft's link attributes for a new link, i.e.:

- aircraft address whose link was successfully established on the new link (minimum information);
- an optional list of one or more subnetwork connections maintained for that aircraft; and
- for each subnetwork connection listed, an indication of whether its subnetwork dependent convergence facility (SNDCF) context was maintained.

As per tables 5.35 and 5.36:

- the aircraft id subfield (a bits) shall be listed once and shall be the aircraft address;
- the optional M/I subfield (m bit) shall be the SNDCF M/I bit in the CALL CONFIRMATION Call User Data field; and
- the optional LCI subfield (1 bits) shall be the logical channel identifier of a subnetwork connection on the old link that is to be maintained on the new link.

Any particular aircraft shall not appear in more than one broadcast parameter block.

Table 5.35: Broadcast connection (link only)

Parameter ID	0	1	0	0		1	0	0	1	Broadcast connection
Parameter length	0	0	0	0		0	0	1	1	
Parameter value	a_{24}	a_{23}	a_{22}	a_{21}		a_{20}	a_{19}	a_{18}	a_{17}	Aircraft ID
	a_{16}	a_{15}	a_{14}	a_{13}		a_{12}	a_{11}	a_{10}	a_9	
	a_8	a_7	a_6	a_5		a_4	a_3	a_2	a_1	
NOTE:	Table 5.35 shows the case of a successful link handoff, with no Switched Virtual Circuits (SVCs) maintained.									

Table 5.36: Broadcast connection (link and subnetwork)

Parameter ID	0	1	0	0		1	0	0	1	Broadcast connection
Parameter length	0	0	0	0		0	1	0	1	
Parameter value	a_{24}	a_{23}	a_{22}	a_{21}		a_{20}	a_{19}	a_{18}	a_{17}	aircraft ID
	a_{16}	a_{15}	a_{14}	a_{13}		a_{12}	a_{11}	a_{10}	a_9	
	a_8	a_7	a_6	a_5		a_4	a_3	a_2	a_1	
	0	0	0	m		1_{12}	1_{11}	1_{10}	1_9	an M/I bit and an LCI
	1_8	1_7	1_6	1_5		1_4	1_3	1_2	1_1	
NOTE:	Table 5.36 shows the case of a successful link handoff, as well as one SVC having been maintained.									

5.3.2.7 Ground-based initiated information private parameters

A ground LME shall use ground-based initiated information parameters to inform one or more aircraft LMEs about that ground-based system's capabilities. Aircraft LMEs shall not send these parameters.

5.3.2.7.1 Frequency support list

This parameter defines the list of frequencies, modulation schemes and associated ground stations supported in the coverage area of the originating ground station. The parameter shall consist of a list of 48-bit entries as shown in table 5.37. The modulation subfield (m bits) shall be encoded as defined in table 5-21. The frequency subfield (f bits) shall be encoded as:

$$\text{Integer } [(\text{frequency in MHz} \times 100) - 10\,000].$$

NOTE: As an example, for a frequency of 131,725 MHz, the encoded value is decimal value 3 172 or hexadecimal C64.

The ground station address (g bits) shall be the DLS address encoded in a 32-bit field as defined in table 5.37. The ground DLS address shall be the DLS address of a ground station which can provide services on the specified frequency and modulation scheme.

No association shall be made between the operating parameters included in the transmitted XID frame and the operating parameters of the ground station(s) listed. During frequency recovery the aircraft LME shall choose randomly a frequency from the list to re-acquire service.

Table 5.37: Frequency support list

Parameter ID	1	1	0	0		0	0	0	0	Frequency support list
Parameter length	n ₈	n ₇	n ₆	n ₅		n ₄	n ₃	n ₂	n ₁	
Parameter value	m ₄	m ₃	m ₂	m ₁		f ₁₂	f ₁₁	f ₁₀	f ₉	
	f ₈	f ₇	f ₆	f ₅		f ₄	f ₃	f ₂	f ₁	
	g ₂₂	g ₂₃	g ₂₄	g ₂₅		g ₂₆	g ₂₇	0	0	
	g ₁₅	g ₁₆	g ₁₇	g ₁₈		g ₁₉	g ₂₀	g ₂₁	0	
	g ₈	g ₉	g ₁₀	g ₁₁		g ₁₂	g ₁₃	g ₁₄	0	
	g ₁	g ₂	g ₃	g ₄		g ₅	g ₆	g ₇	0	

5.3.2.7.2 Airport coverage indication parameter

This parameter defines a list of four-character airport identifiers of airports for which the ground station can support communication with aircraft on the ground. Each four-character identifier shall be encoded as four 8-bit ISO IA5 characters as per table 5.38.

Table 5.38: Airport coverage indication parameter

Parameter ID	1	1	0	0		0	0	0	1	Airport coverage indication
Parameter length	n ₈	n ₇	n ₆	n ₅		n ₄	n ₃	n ₂	n ₁	
Parameter value	a ₈	a ₇	a ₆	a ₅		a ₄	a ₃	a ₂	a ₁	(first character)
	b ₈	b ₇	b ₆	b ₅		b ₄	b ₃	b ₂	b ₁	
	c ₈	c ₇	c ₆	c ₅		c ₄	c ₃	c ₂	c ₁	
	d ₈	d ₇	d ₆	d ₅		d ₄	d ₃	d ₂	d ₁	(fourth character)

5.3.2.7.3 Nearest airport parameter

This parameter defines the four-character airport ID of the airport nearest the ground station. It shall be encoded as four 8-bit ISO IA5 characters as per table 5.39. The nearest airport parameter shall not be included in an XID if the Airport Coverage Indication is included.

Table 5.39: Nearest airport parameter

Parameter ID	1	1	0	0		0	0	1	1	Nearest airport
Parameter length	0	0	0	0		0	1	0	0	
Parameter value	A ₈	a ₇	a ₆	a ₅		a ₄	a ₃	a ₂	a ₁	(first character)
	B ₈	b ₇	b ₆	b ₅		b ₄	b ₃	b ₂	b ₁	
	C ₈	c ₇	c ₆	c ₅		c ₄	c ₃	c ₂	c ₁	
	D ₈	d ₇	d ₆	d ₅		d ₄	d ₃	d ₂	d ₁	(fourth character)

5.3.2.7.4 ATN router NETs parameter

This parameter defines a list of ATN air-ground routers identified by the administration identifier and Administration Region Selector (ARS) subfields of their network entity titles (NETs). It shall be encoded as per table 5.40.

Table 5.40: ATN router NETs parameter

Parameter ID	1	1	0	0		0	1	0	0	ATN router NETs
Parameter length	n ₈	n ₇	n ₆	n ₅		n ₄	n ₃	n ₂	n ₁	
Parameter value	a ₂₄	a ₂₃	a ₂₂	a ₂₁		a ₂₀	a ₁₉	a ₁₈	a ₁₇	ADM subfield
	a ₁₆	a ₁₅	a ₁₄	a ₁₃		a ₁₂	a ₁₁	a ₁₀	a ₉	
	a ₈	a ₇	a ₆	a ₅		a ₄	a ₃	a ₂	a ₁	
	R ₂₄	r ₂₃	r ₂₂	r ₂₁		r ₂₀	r ₁₉	r ₁₈	r ₁₇	ARS subfield
	R ₁₆	r ₁₅	r ₁₄	r ₁₃		r ₁₂	r ₁₁	r ₁₀	r ₉	
	R ₈	r ₇	r ₆	r ₅		r ₄	r ₃	r ₂	r ₁	

5.3.2.7.5 Ground-based system mask parameter

This parameter defines the ground-based system mask. It shall be encoded as a 27-bit mask in a 32-bit field as per table 5.41.

Table 5.41: Ground-based system mask parameter

Parameter ID	1	1	0	0		0	1	0	1	Ground-based system mask
Parameter length	0	0	0	0		0	1	0	0	
Parameter value	g ₂₂	g ₂₃	g ₂₄	g ₂₅		g ₂₆	g ₂₇	0	0	
	g ₁₅	g ₁₆	g ₁₇	g ₁₈		g ₁₉	g ₂₀	g ₂₁	0	
	g ₈	g ₉	g ₁₀	g ₁₁		g ₁₂	g ₁₃	g ₁₄	0	
	g ₁	g ₂	g ₃	g ₄		g ₅	g ₆	g ₇	0	

5.3.2.7.6 Timer TG3 parameter

This parameter defines the value of Timer TG3 (in half-seconds) that the ground LME is using. It shall be encoded as a pair of unsigned 16-bit integers as per table 5.42.

Table 5.42: Timer TG3 parameter

Parameter ID	1	1	0	0		0	1	1	0	Timer TG3
Parameter length	0	0	0	0		0	1	0	0	
Parameter Value	1 ₁₆	1 ₁₅	1 ₁₄	1 ₁₃		1 ₁₂	1 ₁₁	1 ₁₀	1 ₉	(lower bound)
	1 ₈	1 ₇	1 ₆	1 ₅		1 ₄	1 ₃	1 ₂	1 ₁	
	u ₁₆	u ₁₅	u ₁₄	u ₁₃		u ₁₂	u ₁₁	u ₁₀	u ₉	(upper bound)
	u ₈	u ₇	u ₆	u ₅		u ₄	u ₃	u ₂	u ₁	

5.3.2.7.7 Timer TG4 parameter

This parameter defines the value of Timer TG4 (in seconds) that the ground LME is using. It shall be encoded as an unsigned 16-bit integer as per table 5.43. A value of 0 shall mean that the ground LME is not using this timer.

Table 5.43: Timer TG4 parameter

Parameter ID	1	1	0	0	0	1	1	1	Timer TG4
Parameter length	0	0	0	0	0	0	1	0	
Parameter value	v ₁₆	v ₁₅	v ₁₄	v ₁₃	v ₁₂	v ₁₁	v ₁₀	v ₉	
	v ₈	v ₇	v ₆	v ₅	v ₄	v ₃	v ₂	v ₁	

5.3.2.7.8 Ground station location parameter

This parameter defines the position of the ground station. It shall be encoded as shown in tables 5.25 and 5.44.

Table 5.44: Ground station location parameter

Parameter ID	1	1	0	0	1	0	0	0	Ground station location
Parameter length	0	0	0	0	0	0	1	1	
Parameter value	v ₁₂	v ₁₁	v ₁₀	v ₉	v ₈	v ₇	v ₆	v ₅	latitude (v)
	v ₄	v ₃	v ₂	v ₁	h ₁₂	h ₁₁	h ₁₀	h ₉	longitude (h)
	h ₈	h ₇	h ₆	h ₅	h ₄	h ₃	h ₂	h ₁	

5.3.3 VME service system parameters

The VME service shall implement the system parameters defined in table 5.45 and detailed in clauses 5.3.4.1 through 5.3.4.5.

Table 5.45: VDL management entity system parameters

Table 5.46	Parameter name	Minimum	Maximum	Mode 2 default	Increment	
TG1 (air only)	Minimum frequency dwell time	20 s	600 s	240 s	1 s	
TG2	Maximum idle activity time	aircraft	120 s	360 s	240 s	1 s
		ground	10 min	4 320 min	60 min	1 min
TG3 (ground only)	Maximum time between transmissions	100 s	120 s	Uniform between 100 s to 120 s	0,5 s	
TG4 (ground only)	Maximum time between GSIFs	100 s	None	N/A	1 s	
TG5	Maximum link overlap time	initiating	0 s	255 s	20 se	1 s
		responding	0 s	255 s	60 s	1 s

5.3.4 VME procedures

5.3.4.1 Minimum frequency dwell time procedure

5.3.4.1.1 Purpose

To set the minimum dwell time on a frequency for an aircraft LME in search of an uplink traffic from a ground station.

5.3.4.1.2 Use

When the aircraft LME has not yet established a link and tunes on a new frequency during frequency search.

5.3.4.1.3 Procedure

The aircraft LME starts the timer LME-TG1-timer with timeTG1. This timer shall be set by an aircraft LME (if it is not already running) when an aircraft tunes to a new frequency during a frequency search. It shall be cancelled when a valid uplink is received from at least one ground station. On expiry of the timer the aircraft station shall:

- a) establish a link with one of the ground-based systems from which it has received a valid uplink;
- b) continue searching; or
- c) if an aircraft does not detect any uplink traffic within TG1 seconds, it shall tune to the next frequency in the search table.

NOTE 1: The duration of TG1 should be chosen to ensure a valid uplink is received from at least one ground-based system before the timer expires.

NOTE 2: There is one Timer TG1 per LME.

5.3.4.1.4 Recommendation

In order to allow an aircraft station an opportunity to link to its most preferred ground-based system, Timer TG1 should not be cancelled unless a valid uplink is received from its most preferred ground-based system.

5.3.4.2 Maximum idle activity time procedure

5.3.4.2.1 Purpose

To set the maximum holding time for LME information on another station.

5.3.4.2.2 Use

When the LME receive a valid message from another station.

5.3.4.2.3 Procedure

The LME starts a LME-TG2-timer with time TG2. The timer shall be restarted on each subsequent receipt of a valid transmission from that station. It shall never be cancelled. If Timer TG2 expires, an LME shall assume that the station is no longer reachable; if a link existed with that station, then site recovery shall be invoked.

NOTE: There is one Timer TG2 for each station being monitored.

5.3.4.3 Maximum time between transmissions procedure

5.3.4.3.1 Purpose

To refresh the transmissions on any frequency.

5.3.4.3.2 Use

After each transmission on any frequency or when the station becomes operational on a new frequency.

5.3.4.3.3 Procedure

The ground station starts a ground-frequency-TG3-timer with random timeTG3. Timer shall be restarted on the transmission of any frame on this frequency. This timer shall never be cancelled. On expiration, if the ground station is operational, then it shall transmit a GSIF. The value of random time TG3 shall consist of a fixed value equal to the minimum value plus a random value uniformly chosen between 0 s and 20 s.

5.3.4.4 Maximum time between GSIFs

5.3.4.4.1 Purpose

To maintain the visibility of the ground station on any frequency.

5.3.4.4.2 Use

On any frequency when the station becomes operational or when it has transmitted a GSIF.

5.3.4.4.3 Procedure

The ground station shall transmit a GSIF after a time random time TG4. The value of time TG4 shall consist of a fixed value equal to the minimum value plus a random value uniformly chosen between 0 s and 20 s.

5.3.4.5 Maximum link overlap time procedure

5.3.4.5.1 Purpose

To set the maximum time that initiating and responding LMEs shall maintain the old link during handoffs.

5.3.4.5.2 Use

After reception or transmission of an `XID_RSP_HO`.

5.3.4.5.3 Procedure

After time TG5 the LME shall either have silently disconnect its half of the old link or retransmitted its `XID_RSP_HO` if it has not initiated the handoff.

5.3.5 Description of LME procedures

The aircraft and ground LMEs shall use the XID frame types listed in table 5.46 and the procedures described in the text below to provide a reliable connection between the aircraft and ground-based system. Frame collision processing (see clause 5.2.11) shall be applied before determining if a frame is illegal or unexpected (see clause 5.3.2). If an LME receives any valid `XID_HO` or `XID_LPM` frame from a system with which it does not have a link, it shall respond with an `XID_LCR` with the d bit set to 1 in the Protocol Violation Cause Code.

Table 5.46: XID parameters(a)

XID parameters			GSIF	Air initiated link establishment		Link parameter modification	
	Source address	Destination address	Ground station	Aircraft	New ground station	Current Ground station	Aircraft
			All aircraft	Proposed ground station	Aircraft	Aircraft	Current ground station
	GI	PI	GSIF (P=0)	XID_CMD_LE (P=1)	XID_RSP_LE (F=1)	XID_CMD_LPM (P=1)	XID_RSP_LPM (F=1)
Public parameters							
Parameter set ID	80h	01h	M	M	M	N/A	N/A
Procedure classes	80h	02h	M	M	M	N/A	N/A
HDLC options	80h	03h	M	M	M	N/A	N/A
N1-downlink	80h	05h	O	N/A	O	N/A	N/A
N1-uplink	80h	06h	O	N/A	O	N/A	N/A
k-downlink	80h	07h	O	N/A	O	N/A	N/A
k-uplink	80h	08h	O	N/A	O	N/A	N/A
Timer T1 - downlink	80h	09h	O	N/A	O	N/A	N/A
Counter N2	80h	0Ah	O	N/A	O	N/A	N/A
Timer T2	80h	0Bh	O	N/A	O	N/A	N/A

			GSIF	Air initiated link establishment		Link parameter modification	
	Source address		Ground station	Aircraft	New ground station	Current Ground station	Aircraft
	Destination address		All aircraft	Proposed ground station	Aircraft	Aircraft	Current ground station
XID parameters	GI	PI	GSIF (P=0)	XID_CMD_LE (P=1)	XID_RSP_LE (F=1)	XID_CMD_LPM (P=1)	XID_RSP_LPM (F=1)
Private parameters							
Parameter set ID	F0h	00h	M	M	M	M	M
Connection management	F0h	01h	N/A	M	M	N/A	N/A
SQP	F0h	02h	N/A	O	O	O	O
XID sequencing	F0h	03h	N/A	M	M	M	M
AVLC specific options	F0h	04h	M	M	M	N/A	N/A
Expedited SN connection	F0h	05h	N/A	O	O	N/A	N/A
LCR cause	F0h	06h	N/A	N/A	N/A	N/A	N/A
Modulation support	F0h	81h	N/A	M	N/A	N/A	N/A
Alternate grd stations	F0h	82h	N/A	O	N/A	N/A	N/A
Destination airport	F0h	83h	N/A	O	N/A	N/A	N/A
Aircraft location	F0h	84h	N/A	O	N/A	N/A	N/A
Autotune frequency	F0h	40h	N/A	N/A	O	N/A	N/A
Repl. ground station	F0h	41h	N/A	N/A	O	N/A	N/A
Timer T4	F0h	42h	O	N/A	O	O	N/A
MAC persistence	F0h	43h	O	N/A	O	O	N/A
Counter M1	F0h	44h	O	N/A	O	O	N/A
Timer TM2	F0h	45h	O	N/A	O	O	N/A
Timer TG5	F0h	46h	O	N/A	O	O	N/A
Timer T3min	F0h	47h	O	N/A	O	N/A	N/A
Address filter	F0h	48h	N/A	N/A	N/A	N/A	N/A
Broadcast connection	F0h	49h	N/A	N/A	N/A	N/A	N/A
Frequency support	F0h	C0h	O	N/A	O	N/A	N/A
Airport coverage	F0h	C1h	M ¹	N/A	O ²	N/A	N/A
Nearest airport ID	F0h	C3h	M ¹	N/A	O ²	N/A	N/A
ATN router NETs	F0h	C4h	M	N/A	M	N/A	N/A
System mask	F0h	C5h	M	N/A	M	N/A	N/A
TG3	F0h	C6h	O	N/A	O	N/A	N/A
TG4	F0h	C7h	O	N/A	O	N/A	N/A
Ground station location	F0h	C8h	O	N/A	O	N/A	N/A
GI = ISO/IEC 13239 [7] Group identifier. PI = ISO/IEC 13239 [7] Parameter identifier. M = Mandatory. O = Optional. N/A = Not applicable. h = hexadecimal. NOTE 1: In a GSIF XID frame it is mandatory to include either the Airport Coverage Indication parameter or the Nearest Airport Identifier parameter but not both. NOTE 2: Where the Airport Coverage Indication parameter and the Nearest Airport Identifier parameter are marked as optional, either parameter may be included in the frame or neither but not both.							

Table 5.47: XID parameters (b)

XID parameters			Ground initiated handoff		Air initiated handoff	
	Source address		Proposed ground station	Aircraft	Aircraft	New ground Station
	Destination address		Aircraft	New Ground station	Proposed ground station	Aircraft
	GI	PI	XID_CMD_HO (P=1)	XID_RSP_HO (F=1)	XID_CMD_HO (P=1)	XID_RSP_HO (F=1)
Public parameters						
Parameter set ID	80h	01h	O	O	O	O
Procedure classes	80h	02h	O	O	O	O
HDLC options	80h	03h	O	O	O	O
N1-downlink	80h	05h	O	N/A	N/A	O
N1-uplink	80h	06h	O	N/A	N/A	O
k-downlink	80h	07h	O	N/A	N/A	O
k-uplink	80h	08h	O	N/A	N/A	O
Timer T1 - downlink	80h	09h	O	N/A	N/A	O
Counter N2	80h	0Ah	O	N/A	N/A	O
Timer T2	80h	0Bh	O	N/A	N/A	O
Private parameters						
Parameter set ID	F0h	00h	M	M	M	M
Connection management	F0h	01h	M	M	M	M
SQP	F0h	02h	O	O	O	O
XID sequencing	F0h	03h	M	M	M	M
AVLC specific options	F0h	04h	O	O	O	O
Expedited SN connection	F0h	05h	O	O	O	O
LCR cause	F0h	06h	N/A	N/A	N/A	N/A
Modulation support	F0h	81h	N/A	N/A	N/A	N/A
Alternate ground stations	F0h	82h	N/A	N/A	O	N/A
Destination airport	F0h	83h	N/A	O	O	N/A
Aircraft location	F0h	84h	N/A	O	O	N/A
Autotune frequency	F0h	40h	N/A	N/A	N/A	O
Repl. ground station	F0h	41h	O	N/A	N/A	O
Timer T4	F0h	42h	O	N/A	N/A	O
MAC persistence	F0h	43h	O	N/A	N/A	O
Counter M1	F0h	44h	O	N/A	N/A	O
Timer TM2	F0h	45h	O	N/A	N/A	O
Timer TG5	F0h	46h	O	N/A	N/A	O
Timer T3min	F0h	47h	O	N/A	N/A	O
Address filter	F0h	48h	N/A	N/A	N/A	N/A
Broadcast connection	F0h	49h	N/A	N/A	N/A	N/A
Frequency support	F0h	C0h	O	N/A	N/A	O
Airport coverage	F0h	C1h	O ²	N/A	N/A	O ²
Nearest airport ID	F0h	C3h	O ²	N/A	N/A	O ²
ATN router NETs	F0h	C4h	M	N/A	N/A	O
System mask	F0h	C5h	O	N/A	N/A	M

XID parameters			Ground initiated handoff		Air initiated handoff	
	Source address		Proposed ground station	Aircraft	Aircraft	New ground Station
	Destination address		Aircraft	New Ground station	Proposed ground station	Aircraft
	GI	PI	XID_CMD_HO (P=1)	XID_RSP_HO (F=1)	XID_CMD_HO (P=1)	XID_RSP_HO (F=1)
TG3	F0h	C6h	O	N/A	N/A	O
TG4	F0h	C7h	O	N/A	N/A	O
Ground station location	F0h	C8h	O	N/A	N/A	O
GI = ISO/IEC 13239 [7] Group identifier. PI = ISO/IEC 13239 [7] Parameter identifier. M = Mandatory. O = Optional. N/A = Not applicable. h = hexadecimal. NOTE 1: In a GSIF XID frame it is mandatory to include either the Airport Coverage Indication parameter or the Nearest Airport Identifier parameter but not both. NOTE 2: Where the Airport Coverage Indication parameter and the Nearest Airport Identifier parameter are marked as optional, either parameter may be included in the frame or neither but not both.						

Table 5.48: XID parameters (c)

XID parameters			Air requested handoff	Ground requested handoff	Ground requested broadcast	Link connection rejection
	Source address		Aircraft	Current ground station	New ground station	Any station
	Destination address		Current or proposed ground station	Aircraft	All aircraft	Any station
	GI	PI	XID_CMD_HO (P=0)	XID_CMD_HO (P=0)	XID_CMD_HO (P=0)	XID_RSP_LCR XID_CMD_LCR
Public parameters						
Parameter set ID	80h	01h	N/A	O	O	N/A
Procedure classes	80h	02h	N/A	O	O	N/A
HDLC options	80h	03h	N/A	O	O	N/A
N1-downlink	80h	05h	N/A	O	O	N/A
N1-uplink	80h	06h	N/A	O	O	N/A
k-downlink	80h	07h	N/A	O	O	N/A
k-uplink	80h	08h	N/A	O	O	N/A
Timer T1 - downlink	80h	09h	N/A	O	O	N/A
Counter N2	80h	0Ah	N/A	O	O	N/A
Timer T2	80h	0Bh	N/A	O	O	N/A
Private parameters						
Parameter set ID	F0h	00h	M	M	M	M
Connection management	F0h	01h	M	M	M	M
SQP	F0h	02h	N/A	N/A	N/A	N/A
XID sequencing	F0h	03h	M	M	M	M
AVLC specific options	F0h	04h	N/A	O	O	N/A
Expedited SN connection	F0h	05h	N/A	N/A	N/A	N/A
LCR cause	F0h	06h	N/A	N/A	N/A	M
Modulation support	F0h	81h	N/A	N/A	N/A	N/A
Alternate ground stations	F0h	82h	O	N/A	N/A	N/A
Destination airport	F0h	83h	O	N/A	N/A	N/A
Aircraft location	F0h	84h	O	N/A	N/A	N/A
Autotune frequency	F0h	40h	N/A	O	N/A	N/A
Repl. ground station	F0h	41h	N/A	O	N/A	N/A

			Air requested handoff	Ground requested handoff	Ground requested broadcast	Link connection rejection
	Source address		Aircraft	Current ground station	New ground station	Any station
	Destination address		Current or proposed ground station	Aircraft	All aircraft	Any station
XID parameters	GI	PI	XID_CMD_HO (P=0)	XID_CMD_HO (P=0)	XID_CMD_HO (P=0)	XID_RSP_LCR XID_CMD_LCR
Timer T4	F0h	42h	N/A	O	O	N/A
MAC persistence	F0h	43h	N/A	O	O	N/A
Counter M1	F0h	44h	N/A	O	O	N/A
Timer TM2	F0h	45h	N/A	O	O	N/A
Timer TG5	F0h	46h	N/A	O	O	N/A
Timer T3min	F0h	47h	N/A	O	O	N/A
Address filter	F0h	48h	N/A	N/A	M	N/A
Broadcast connection	F0h	49h	N/A	N/A	M	N/A
Private parameters						
Frequency support	F0h	C0h	N/A	O	O	N/A
Airport coverage	F0h	C1h	N/A	N/A	O ²	N/A
Nearest airport ID	F0h	C3h	N/A	N/A	O ²	N/A
ATN router NETs	F0h	C4h	N/A	O	M	N/A
System mask	F0h	C5h	N/A	O	O	N/A
TG3	F0h	C6h	N/A	O	O	N/A
TG4	F0h	C7h	N/A	O	O	N/A
Ground station location	F0h	C8h	N/A	O	O	N/A
GI = ISO/IEC 13239 [7] Group identifier. PI = ISO/IEC 13239 [7] Parameter identifier. M = Mandatory. O = Optional. N/A = Not applicable. h = hexadecimal. NOTE 1: In a GSIF XID frame it is mandatory to include either the Airport Coverage Indication parameter or the Nearest Airport Identifier parameter but not both. NOTE 2: Where the Airport Coverage Indication parameter and the Nearest Airport Identifier parameter are marked as optional, either parameter may be included in the frame or neither but not both.						

5.3.5.1 Frequency management procedures

The aircraft LME shall use the following procedures to acquire a frequency on which reliable VDL services are available.

5.3.5.1.1 Frequency search

The aircraft LME shall initiate the frequency search procedure on system initialization or after link disconnection, if it can no longer detect uplink VDL frames on the current frequency. It shall attempt to identify a frequency on which VDL service is available by tuning the radio to the CSC and to other frequencies on which it knows a-priori that VDL service is available. It shall scan until it detects a valid uplink VDL frame with an acceptable source address or until Timer TG1 expires, in which case it shall tune the radio to another frequency and continue to scan.

5.3.5.1.2 Frequency recovery

The aircraft LME shall initiate the frequency recovery procedure if it can no longer establish a link on the current frequency or if the MAC entity indicates that the current frequency is congested. It shall tune the radio to an alternate frequency using the data in the Frequency Support List previously received on the current link.

5.3.5.2 Link connectivity procedures

The aircraft and ground LMEs shall use the following procedures to maintain connectivity across the VHF link:

- a) ground station identification;
- b) initial link establishment;
- c) link parameter modification;
- d) aircraft-initiated handoff;
- e) aircraft-requested ground-based initiated handoff;
- f) ground-based initiated handoff;
- g) ground-based requested aircraft-initiated handoff;
- h) ground-based requested broadcast handoff; and
- i) autotune.

5.3.5.3 Ground station identification

A ground station shall send a GSIF by broadcasting a XID_CMD (P=0) with parameters as per table 5.46 if its Timer TG3 expires, (meaning that it has not transmitted any frame in TG3), seconds, or if its Timer TG4 expires, (meaning that it has not sent a GSIF in TG4 seconds). If a ground station offers Mode 2 service, the operator of that ground station shall ensure that, besides transmitting GSIFs on the service frequency, GSIFs are transmitted on the CSC. Aircraft LMEs receiving a GSIF shall process its content to identify the functionality of the ground station as well as the correct operational parameters to be used when communicating with it. Aircraft LMEs which have a connection with the transmitting ground station shall process only informational parameters and those parameters specified for an XID_CMD_LPM as per table 5.46.

5.3.5.4 Link establishment

The aircraft LME shall initiate the link establishment procedure with a ground station only to establish an initial link with the ground-based system. An aircraft transmitting or receiving a DM frame shall initiate link establishment if no links remain.

5.3.5.4.1 Aircraft initiation

The aircraft LME shall choose a ground station with which it wishes to establish a link based on the signal quality of all received uplink frames and on information in any received GSIFs. It shall then attempt to establish a link with the chosen ground station by sending an XID_CMD_LE (P=1) frame. This frame shall include the mandatory parameters as per table 5.46 and also any optional parameters for which the aircraft LME does not wish to use the default value. If the aircraft LME has received a GSIF from the ground station to which it is transmitting the XID_CMD_LE (P=1), then it shall use the parameters as declared; otherwise, it shall use the default parameters.

5.3.5.4.2 General ground response

If the ground LME receives the XID_CMD_LE, it shall confirm link establishment by sending an XID_RSP_LE frame containing the parameters as per table 5.46. The ground LME shall include in the XID_RSP_LE any optional parameters for which it is not using the default values. If the XID_RSP_LE includes the Autotune parameter then the Replacement Ground Station List parameter shall be included indicating the ground stations on the new frequency that the aircraft LME can establish a new link using the operating parameters specified in the XID_RSP_LE. If the XID_RSP_LE does not include the Autotune parameter, the ground LME shall include the Replacement Ground Station List parameter if it wishes to indicate the ground stations which can be reached on the current frequency using the same operating parameters as the transmitting station.

5.3.5.4.3 Exceptional cases

If an LME receiving the `XID_CMD_LE` cannot establish the link with the sending LME, then it shall transmit an `XID_RSP_LCR` (F=1) instead of an `XID_RSP_LE` (F=1).

If the parameters in the `XID_RSP_LE` from the ground LME are not acceptable to the aircraft LME, then the aircraft LME shall transmit a DISC to the ground.

If the Autotune parameter is included in the `XID_RSP_LE` and the aircraft LME is unable to perform the autotune, then the aircraft LME shall respond with an `XID_CMD_LCR` (P=0); the link established on the current frequency shall not be affected.

While waiting for a response to an `XID_CMD_LE`, an aircraft LME receiving any unicasted frame other than a TEST or an XID shall retransmit the `XID_CMD_LE` instead of transmitting a DM.

NOTE: See clause 5.2.11 on the processing of an `XID_CMD`.

5.3.5.5 Link parameter modification

5.3.5.5.1 Ground-based initiation

The ground LME shall request a modification of an existing link connection's parameters by sending an `XID_CMD_LPM` (P=1) to the aircraft LME containing the parameters as per table 5.46.

5.3.5.5.2 General aircraft response

The aircraft LME shall acknowledge with an `XID_RSP_LPM` containing the parameters as per table 5.46.

5.3.5.5.3 Recommendation

If Counter N2 is exceeded for the `XID_CMD_LPM`, the ground LME should attempt to handoff via another station before disconnecting the link to the aircraft.

5.3.5.6 Aircraft-initiated handoff

If an aircraft LME implements this clause, then it shall set the `i` bit in the AVLC Specific Options parameter to 1; otherwise, it shall set the `i` bit to 0.

5.3.5.6.1 Aircraft handoff

Once the aircraft LME has established a link to a ground station, it shall monitor the VHF signal quality on the link and the transmissions of the other ground stations. The aircraft LME shall establish a link to a new ground station if any of the following events occur:

- a) the VHF signal quality on the current link is poor and the signal quality of another ground station is significantly better;
- b) Counter N2 is exceeded on any frame sent to the current ground station;
- c) Timer TG2 expires for the current link; or
- d) Timer TM2 expires. In this case, the aircraft LME shall autonomously tune to an alternate frequency (provided in a frequency support list) before initiating the handoff.

5.3.5.6.2 Site selection preference

From among those ground stations with acceptable link quality, the aircraft LME shall prefer to handoff to a ground station which indicates (in the GSIF) accessibility to the air-ground router(s) to which the aircraft DTE has subnetwork connections.

5.3.5.6.3 Recommendation

If an aircraft has commenced approach to its destination airport and its current link is with a ground station that does not offer service at that airport, it should handoff to a ground station which indicates in its Airport Coverage Indication parameter that it offers service at that airport.

5.3.5.6.4 Interaction of LMEs

When an aircraft VME hands off from a ground station in one ground-based system (and thus associated with one LME) to a ground station in another ground-based system (and thus associated with a different LME in the aircraft), the new LME shall use the link establishment procedures and the old LME shall send a DISC when directed by the VME.

NOTE: Optimally the old link should not be disconnected until after the new link is capable of carrying application data.

5.3.5.6.5 General ground response

If the ground LME receives the `XID_CMD_HO`, it shall confirm link handoff by sending an `XID_RSP_HO` frame containing the parameters as per table 5.46. The ground LME shall include in the `XID_RSP_HO` the optional parameters for which it is not using the default values. If the `XID_RSP_HO` includes the Autotune parameter, then the Replacement Ground Station List parameter shall be included to indicate the ground stations with which the aircraft LME can establish a new link on the new frequency, using the operating parameters specified in the `XID_RSP_HO`. If the `XID_RSP_HO` does not include the Autotune parameter, the ground LME shall include the Replacement Ground Station List parameter if it wishes to indicate the ground stations which can be reached on the current frequency using the same operating parameters as the transmitting station.

5.3.5.6.6 Disconnecting old link

If the new and old ground stations are associated with different systems, then the procedures of clause 5.3.5.6.4 shall be followed. Otherwise, the aircraft LME shall set Timer TG5 when it receives the `XID_RSP_HO`. The ground LME shall set Timer TG5 after it transmits the `XID_RSP_HO`. Both stations shall continue to operate on the old link until their respective Timer TG5 expires, after which each will consider the link disconnected without sending or receiving a DISC.

5.3.5.6.7 Exceptional cases

If the ground LME cannot satisfy the `XID_CMD_HO`, then it shall transmit an `XID_RSP_LCR` instead of an `XID_RSP_HO`; the current link shall not be affected.

While waiting for a response to an `XID_CMD_HO`, an aircraft LME receiving any unicast frame other than a TEST or an XID from any ground station other than the current station shall retransmit the `XID_CMD_HO`.

If Counter N2 is exceeded on the `XID_CMD_HO`, the aircraft LME shall attempt to handoff to another ground station; the current link shall not be affected.

If the aircraft LME cannot perform the autotune, it shall transmit an `XID_CMD_LCR` (P=0); the current link shall not be affected.

If the parameters in the `XID_RSP_HO` are not acceptable to the aircraft LME, then the aircraft LME shall transmit a DISC to the ground on the new link.

5.3.5.7 Aircraft-requested ground-initiated handoff

An aircraft LME shall not perform this clause when its peer LME does not support handoff initiation. An aircraft LME shall only perform this clause if the current and proposed ground stations are both managed by its peer LME.

5.3.5.7.1 Aircraft action

For an aircraft LME to request the ground LME to initiate a handoff, it shall send an `XID_CMD_HO` (P=0) addressed to its current or proposed ground station with the parameters as per table 5.46. During this procedure the current link shall not be affected until the aircraft LME receives an `XID_CMD_HO` (P=1).

5.3.5.7.2 General ground response

If the ground LME receives the `XID_CMD_HO`, it shall commence a ground-initiated handoff from a proposed ground station. The ground LME shall only transmit the `XID_CMD_HO` (P=1) once per `XID_CMD_HO` (P=0) request that it receives.

5.3.5.7.3 Exceptional cases

If the ground system cannot initiate the handoff, it shall send an `XID_CMD_LCR` (P=0); the current link shall not be affected.

If Counter N2 is exceeded for the `XID_CMD_HO`, the aircraft LME should attempt to request to handoff to another station before disconnecting all links to the ground and restarting link establishment.

5.3.5.8 Ground-based initiated handoff0

If a ground LME implements this clause, then it shall set the `Ai` bit in the AVLC Specific Options parameter to 1; otherwise, it shall set the `Ai` bit to 0.

5.3.5.8.1 Ground action

To command an aircraft, to which a link exists, to establish a new link to a proposed ground station on the same frequency, the ground LME shall send via that ground station an `XID_CMD_HO` (P=1) to the aircraft with parameters as per table 5.46. If the ground LME will accept a handoff to other ground stations, the `XID_CMD_HO` shall include the Replacement Ground Station List parameter specifying the link layer address of those other stations. Any operating parameters in the `XID_CMD_HO` (either modification or informational) shall be valid for the transmitting station and for all ground stations listed in the Replacement Ground Station List parameter, except the Airport Coverage Indication parameter and Nearest Airport parameter which are only valid for the transmitting ground station.

5.3.5.8.2 General aircraft response

The aircraft LME shall respond by sending an `XID_RSP_HO` with parameters as per table 5.46 to either the proposed ground station or to its preferred ground station if the `XID_CMD_HO` included the Replacement Ground Station List parameter.

5.3.5.8.3 Disconnecting old link

The aircraft LME shall set Timer TG5 after it transmits the `XID_RSP_HO`. The ground LME shall set Timer TG5 when it receives the `XID_RSP_HO`. Although new traffic will be sent over the new link, the old link shall not be disconnected immediately to allow any old traffic to be delivered.

5.3.5.8.4 Exceptional cases

If the aircraft LME cannot accept the handoff request, it shall respond with an `XID_RSP_LCR`; the current link shall not be affected.

While waiting for a response to an `XID_CMD_HO`, a ground LME receiving any unicasted frame other than a TEST or an XID from the aircraft shall retransmit the `XID_CMD_HO`.

If the parameters in the `XID_RSP_HO` are not acceptable to the ground LME, then the ground LME shall transmit a DISC to the aircraft on the new link.

5.3.5.8.5 Recommendation

If Counter N2 is exceeded for the `XID_CMD_HO`, the ground LME should attempt to handoff via another station before disconnecting all links to the aircraft.

5.3.5.9 Ground-based requested aircraft-initiated handoff0.4.4.9

A ground LME shall not perform this clause with aircraft that do not support handoff initiation.

5.3.5.9.1 Ground action

For the ground LME to request an aircraft to initiate a handoff, it shall send an `XID_CMD_HO` (P=0) on the current link with parameters as per table 5.46. The parameters in the `XID` (both modification and informational) are valid for all ground stations listed in the Replacement Ground Station List. It shall only include operational parameters if it also includes the Replacement Ground Station List parameter. If the Autotune parameter is included, then the Replacement Ground Station List parameter shall apply to the new frequency.

5.3.5.9.2 General aircraft response

If the aircraft LME receives the `XID_CMD_HO`, it shall commence an aircraft-initiated handoff to a ground station, preferably one listed in the Replacement Ground Station List parameter.

5.3.5.9.3 Exceptional cases

If the aircraft LME cannot initiate the handoff, it shall send an `XID_CMD_LCR` (P=0); the current link shall not be affected.

If the Autotune parameter is included in the `XID_CMD_HO` (P=0), the aircraft LME shall retransmit on the new frequency the `XID_CMD_HO` (P=1) using the normal retransmission procedures; otherwise, it shall only transmit the `XID_CMD_HO` (P=1) once per received `XID_CMD_HO` (P=0).

5.3.5.9.4 Recommendation

If Counter N2 is exceeded for the `XID_CMD_HO`, the ground LME should attempt to request a handoff via another station before disconnecting all links to the aircraft.

5.3.5.10 Ground-based requested broadcast handoff

If the ground LME broadcasts link handoffs then it shall set the b_1 bit in the AVLC options parameter to 1; otherwise, it shall set the b_1 bit to 0. If the ground LME supports broadcast subnetwork connection handoff, the ground LME shall also support broadcast link handoffs and shall set the b_1 and b_s bits in the AVLC options parameter to 1; otherwise, it shall set the b_s bit to 0.

5.3.5.10.1 Ground action

If the ground LME supports broadcast link handoffs, for each aircraft that indicates it supports broadcast link handoff, the ground LME shall confirm the link handoff by including the Broadcast Connection parameter per table 5.46. If the ground LME supports broadcast subnetwork connection management, for each aircraft that indicates it supports broadcast subnetwork connection management, the ground LME shall confirm the link handoff and the subnetwork connection maintenance by including the Broadcast Connection parameter per table 5.46.

5.3.5.10.2 Aircraft response

The LME in each aircraft shall process received broadcast `XID_CMD_HO` (P=0) and determine if the ground LME had performed a broadcast link recovery (and possibly an expedited subnetwork recovery) for it. It shall do this by verifying that the Ground Station Address Filter parameter contains the DLS address of the ground station that it is connected to and that a Broadcast Connection parameter exists containing its aircraft address. Aircraft LMEs supporting broadcast recovery shall consider that a link handoff has occurred with the new link having the same parameters as the old link (as modified by the parameters in the broadcast `XID`). The old link shall be disconnected immediately.

The Broadcast Connection parameter shall include the subnetwork connection information (i.e. the M/I and LCI subfields) for only those subnetwork connections between the aircraft DTE and the peer ground DTEs that the ground LME maintained. Aircraft LMEs supporting broadcast subnetwork connection management shall process the remainder of the Broadcast Connection parameter to determine which subnetwork connections the ground LME maintained. For those subnetwork connections associated with the logical channels on the old link that the ground LME maintained, the aircraft DTE shall consider as if the CALL REQUEST and CALL CONFIRMATION sent on the old link were resent on the new link (except that the M/I bit in the Broadcast Connection parameter shall supersede the value in the previous CALL CONFIRMATION). At this point the aircraft DTE, ground DCE, and ground DTE shall be initialized. If the Broadcast Connection parameter indicates that the ground was not able to maintain a subnetwork connection (i.e. a particular LCI is not mentioned in the Broadcast Connection parameter), the aircraft shall explicitly establish this subnetwork connection as per clause 4.6.3.3.1.

5.3.5.10.3 Exceptional cases

If the aircraft LME does not support broadcast recovery, but the ground LME performed a broadcast link recovery for it, then the aircraft LME shall perform either an air-initiated link handoff, (if the aircraft LME supports same) or request a link handoff.

If the aircraft LME finds the new ground station unacceptable, it shall perform an air-initiated handoff (if the aircraft LME supports same) or request a link handoff.

If the Ground Station Address Filter parameter does not equal the DLS address of a link that the aircraft LME has or if no aircraft identifier subfield in a Broadcast Connection parameter equals its aircraft address, the aircraft LME shall not process the ground requested broadcast handoff.

If the aircraft LME supports broadcast link handoffs but does not support broadcast subnetwork connection management and the Broadcast Connection field is implemented as per table 5-36, the aircraft LME shall explicitly establish its subnetwork connections.

If the Broadcast Connection parameter indicates that a subnetwork connection was maintained, but the aircraft LME does not recognize that subnetwork connection, then the aircraft DTE shall transmit a CLEAR REQUEST for each unrecognized subnetwork connection.

5.3.5.11 Ground-based commanded autotune

This clause summarizes the autotune details found in clauses 3.4.4.3, 3.4.4.5 and 3.4.4.8.

5.3.5.11.1 Ground action

To command an aircraft LME to handoff to a ground station on a different frequency, the ground LME shall include the Autotune and Replacement Ground Station List parameters in an XID it sends during a link establishment or handoff procedure.

5.3.5.11.2 General aircraft response

On receipt of an XID commanding an autotune, the aircraft LME shall retune the aircraft radio to the new frequency and commence an aircraft-initiated handoff to the chosen ground station.

5.3.5.11.3 Exceptional cases

If the aircraft LME cannot perform the autotune, it shall transmit an XID_CMD_LCR (P=0); the current link shall not be affected.

5.3.5.12 Expedited subnetwork connection management

If a LME implements this clause, then it shall set the "v" bit in both the AVLC Specific Options and in the Connection Management parameters to 1; otherwise it shall set them to 0. This clause shall only be applicable for the link establishment, air initiated handoff, and ground initiated handoff processes.

5.3.5.12.1 Initiating station of subnetwork connection management

To perform an expedited subnetwork connection establishment or maintenance, the initiating LME shall include in the XID_CMD the Expedited Subnetwork Connection parameter for each subnetwork connection that needs to be established or maintained. The procedures for an expedited link establishment and maintenance shall be the same as outlined in clauses 5.3.5.4, 5.3.5.6 and 5.3.5.8.

5.3.5.12.2 General responder action

If the responding LME receives a XID_CMD with one or more Expedited Subnetwork Connection parameters, it shall confirm subnetwork connection establishment or maintenance by sending an XID_RSP containing the parameters as per table 5.46. The responding LME shall attempt to establish or maintain the specified subnetwork connections as outlined in clause 4.6.3. The responding LME shall include in the XID_RSP the CALL CONFIRMATION or CLEAR REQUEST responses (i.e. in the Expedited Subnetwork Connection parameter) and any optional parameters for which it is not using the default values. The ground LME shall not process the Expedited Subnetwork Connection parameters if it includes the Autotune parameter in the XID_RSP.

5.3.5.12.3 Exceptional cases

If the responding LME cannot support the expedited subnetwork connection establishment or maintenance but can support the link establishment or handoff, it shall respond with XID_RSP with the Connection Management Av bit set to 0 and shall not include the Expedited Subnetwork Connection parameters in the XID_RSP.

If T3min expires, the responding LME shall include all responses (i.e. CALL CONFIRMATION or CLEAR REQUEST) that it has received up to that point in the XID_RSP. Any late responses from respective DTE(s) shall be sent to the initiating LME in INFO frames.

NOTE: All XID_CMD retransmissions will cause the responding LME to respond with the same XID_RSP without further processing. All late subnetwork connection responses from ground DTEs will not be included in the retransmitted XID_RSP.

6 Subnetwork layer protocols and services functional specifications

6.1 Architecture

The subnetwork layer protocol used across the VHF air-ground subnetwork is referred to formally as a SubNetwork Access Protocol (SNAcP) and shall conform to ISO/IEC 8208 [5], except as noted below. The SNAcP is referred to within the present document as the subnetwork protocol. If there are any differences between the present document and the cited specifications, the present document shall have precedence. On the air-ground interface, the aircraft subnetwork entity shall act as a DTE and the ground subnetwork entity shall act as a DCE.

6.1.1 Access points

The SubNetwork Service Access Point (SNSAP) shall be uniquely identified by the subnetwork Data Terminal Equipment (DTE) address. SNSAPs shall define the subnetwork point of attachment (SNPA) used by the service primitives that define the subnetwork service to the subnetwork dependence convergence protocol.

6.2 Services

This clause specifies the services offered by the subnetwork sublayer. The services are described in an abstract manner and do not imply any particular implementations. The services provided by the subnetwork to the subnetwork service user shall include the functions described in clauses 6.2.1 through 6.2.4.

6.2.1 Subnetwork connection management

A variety of ISO/IEC 8208 [5] packet types, procedures, and facilities shall be used to establish, terminate, and manage connections across the subnetwork. Connection status information shall be maintained at both ends of the connection. Connection status information shall also be maximized to ensure that the minimum amount of information is passed with each data transfer phase transmission and that ground system operational control of the subnetwork is maximized.

6.2.2 Packet fragmentation and reassembly

This subnetwork capability shall allow the fragmenting of large data units passed from the subnetwork user for transmission across the air-ground portion of the subnetwork. Reassembly shall be performed at the receiving end of the subnetwork.

6.2.3 Error recovery

REJECT packet types shall be used for subnetwork-level error recovery. These packets shall be sent between subnetwork entities to cause retransmission of invalid packets and to recover from error response time-out states. Under no circumstances shall RESET or RESTART be used to recover from an error that can be handled by REJECT. Aircraft DTEs shall accept REJECT packets and should retransmit the specified packets.

6.2.3.1 Recommendation

The ground DCE with which an aircraft has a VDL link should not clear subnetwork connections on receipt of REJECT packets but should retransmit the specified packet.

6.2.4 Connection flow control

DATA packet sequence numbering combined with the use of a sliding window shall be used for passive flow control.

6.2.4.1 Recommendation

Receive Not Ready (RNR) packets should not be used for explicit flow control.

NOTE: The use of explicit RNRs requires a subsequent packet to clear the f2 (DXE RECEIVE NOT READY) state (see ISO/IEC 8208 [5]). The RNRs and subsequent RR frames will cause more RF utilization than would be caused by merely delaying the acknowledgment.

6.3 Packet format

Except as qualified below, the packet format shall be as specified in ISO/IEC 8208 [5], clause 12. During call setup, VDL shall use the extended format in conjunction with the fast select facility.

6.3.1 General format identifier

The Qualifier bit (Q-bit) in DATA packets shall be set to 0 in VDL. Modulo 8 sequencing shall be used in the VDL.

NOTE: A subnetwork entity may receive a CLEAR CONFIRMATION with the appropriate cause code if the peer subnetwork entity wants to use modulo 128 sequencing.

6.3.2 Calling and called DTE addresses

Calling and called DTE addresses shall be as detailed in clauses 4.3.2.1 through 4.3.2.3.

6.3.2.1 Encoding

Octet 5 and consecutive octets shall consist of the following addresses, in order:

- a) called DTE address; and
- b) calling DTE address.

6.3.2.1.1 Address field

This variable length field is known informally as the address field. The address field shall be encoded in a BCD form. When appropriate, the address field shall be rounded up to an integer number of octets.

6.3.2.2 Aircraft DTE address

The aircraft DTE address shall be the BCD encoding of the octal representation of the 24-bit ICAO aircraft address.

6.3.2.3 Ground DTE address

The VDL subnetwork-specific ground DTE addresses shall be the BCD encoding of the ADM, and optionally the ARS field (from the NET, as defined in the ATN Manual). It shall be sent in the Called Address Extension facility. Bit 8 of the first octet after the facility code shall be set to 1 and bit 7 shall be set to 0. The Called Address shall not be included when using VDL subnetwork-specific ground DTE addresses.

6.3.2.4 Ground network DTE addresses

If the ground LME indicates support of ground network DTE addresses during link establishment, it shall accept and process addresses which follow the format used in the ground network. All CALL REQUESTs from the ground shall use, as the Calling Address, the ground DTEs X.121 address.

NOTE: This facility allows addressing of ground DTEs other than those associated with the ATN routers in the list of ATN router NETs. It requires however that the aircraft System Management Entity (SME) know or be informed via an application exchange of the address of the DTE in the ground network.

6.3.3 Call user data field

The fast select facility shall be used to carry the VDL mobile SNDCF Call User Data, including the intermediate system hello (ISH) PDU.

NOTE: This reduces the number of transmissions required to setup the various layers. Refer to the ATN Manual [1], chapter 11.

6.3.4 Packet types

All packet types (except the INTERRUPT, INTERRUPT CONFIRMATION, and RECEIVE NOT READY) shall be used in the VDL. Packet encoding shall be as specified in ISO/IEC 8208 [5].

6.4 Subnetwork layer service system parameters

The parameters listed in table 6.1 shall be used in the subnetwork protocol. Except as noted in clause 4.6, the description of function and procedures shall be as documented in ISO/IEC 8208 [5]. For all parameters, table 6.1 indicates the configured or negotiated values that shall be used by the aircraft DTE and the ground DCE. T21, T23, and R23 shall also apply to the ground DTE.

Table 6.1: Subnetwork layer service system parameters

Symbol	Name	Minimum	Maximum	Mode 2 standard
T20	RESTART REQUEST response timer	1 s	300 s	180 s
T21	CALL REQUEST response timer	1 s	300 s	200 s
T22	RESET REQUEST response timer	1 s	300 s	180 s
T23	CLEAR REQUEST response timer	1 s	300 s	180 s
R20	RESTART REQUEST retransmission count	0	7	1
R22	RESET REQUEST retransmission count	0	7	1
R23	CLEAR REQUEST retransmission count	0	7	1
P	Packet size	128 octets	2 048 octets	1 024 octets
W	Transmit window size	1 packet	7 packets	7 packets
A	Acknowledgment window size	1 packet	4 packets	4 packets
LTC	Lowest two-way channel	0	4 095	1 024
HTC	Highest two-way channel	0	4 095	3 071

P, W, A values define defaults. Other parameter values are preset and not negotiated. The packet size (P) and window sizes (W, A) define defaults, and may be negotiated during call setup.

6.4.1 Packet size

The Packet Size shall be negotiated via the flow control parameter negotiation facility or nonstandard Default Packet Size facility to be the value in table 5.1 appropriate to the mode for both directions.

6.4.2 Parameter W (transmit window size)

The parameter W shall be the maximum number of outstanding sequentially numbered data packets that may be transmitted before an acknowledgement is required. In the absence of negotiations via the nonstandard default window size facility or the flow control parameter negotiation facility, this parameter shall be as per table 5-1. W shall be negotiated to the same value in both directions.

This parameter is identical to the standard ISO/IEC 8208 [5], parameter W.

6.4.3 Parameter A (acknowledgment window size)

This parameter, A, shall be the minimum number of frames the receiver shall receive before it generates an RR packet. Parameter A shall not be separately negotiated, but shall be set equal to the ceiling of one-half of W.

6.5 Effects of layers 1 and 2 on the subnetwork layer

The subnetwork layer virtual circuit shall be valid only on the underlying link layer connection over which it was established.

6.6 Description of procedures

Except where noted in clauses 6.6.1 through 6.6.5, the provisions of ISO/IEC 8208 [5] shall apply between the aircraft DTE and the ground DCE. If a ground DCE receives an unsupported packet layer facility, it shall either process the CALL REQUEST without altering the facilities or shall send a CLEAR CONFIRMATION.

6.6.1 Supported facilities

Table 6.2 lists options and facilities, documented in ISO/IEC 8208 [5], that shall be supported by VDL.

Table 6.2: Facilities supported by the VDL

Facility	ISO/IEC 8208 [5], clause
Packet retransmission	13.4
Nonstandard default packet sizes	13.9
Nonstandard default window sizes	13.10
Flow control parameter Negotiation	13.12
Fast select	13.16
Fast select acceptance	13.17
Called line address modified notification	13.26
Called address extension	14.2

6.6.2 Unsupported facilities

Table 6.3 lists the facilities, documented in ISO/IEC 8208 [5] that shall not be supported by the VDL.

Table 6.3: Facilities Not Supported

Facility	ISO/IEC 8208 [5], clause
Q-bit	6.6
Non-receipt of window rotation information	11.2
Window status transmission timer (Timer T24)	11.2.2
On line facility registration	13.1
Extended packet seq. numbering	13.2
D-bit modification	13.3
Reject response timer (Timer T27)	13.4.1
Incoming calls barred	13.5
Outgoing calls barred	13.6
One-way logical channel outgoing	13.7
One-way logical channel incoming	13.8
Default throughput classes assignment	13.11
Throughput class negotiation	13.13
Closed user group related facilities	13.14
Bilateral closed user group related facilities	13.15
Reverse charging	13.18
Reverse charging acceptance	13.19
Local charging prevention	13.20
Network user identification	13.21
Charging information	13.22
RPOA selection	13.23
Hunt group	13.24
Call redirection	13.25
Call redirection notification	13.27
Transit delay selection and indication	13.28
Calling address extension	14.1
Minimum throughput class negotiation	14.3
End-to-end transit delay negotiation	14.4
Expedited data negotiation	14.5

6.6.3 Subnetwork establishment and connection management

The subnetwork establishment and connection management options used shall be chosen as required by the operational conditions.

6.6.3.1 Subnetwork entity initialization

The ground DCE shall be initialized on receipt of a valid `XID_CMD_LE`. The aircraft DCE shall be initialized on receipt of a valid `XID_RSP_LE`.

NOTE: Only the subnetwork entities corresponding to the link on which the `XID_CMD_LE`/`XID_RSP_LE` is received will be initialized. The entities assigned to other links will not be affected.

6.6.3.2 Subnetwork connection establishment

Only aircraft DTEs shall request subnetwork connection establishment in the VDL subnetwork.

6.6.3.2.1 Explicit subnetwork connection establishment

Immediately after link establishment, the aircraft DTE shall attempt to establish a subnetwork connection to at least one ground DTE. The aircraft DTE shall request a single subnetwork connection per ground DTE by the transmission of a `CALL REQUEST` packet specifying the ground DTE address in the Called Address field. On receipt of the `CALL REQUEST`, the ground DCE shall attempt to establish a subnetwork connection to the specified DTE. A `CALL CONFIRMATION` packet shall be sent to the aircraft DTE if the connection is established; otherwise a `CLEAR REQUEST` packet including a diagnostic specifying the cause of failure shall be sent. The ground DCE shall use the Called Line Address Modified Notification facility to inform the aircraft DTE of the ground DTE's X.121 address.

NOTE: The Calling Address field in `CLEAR CONFIRMATION` packet will contain the Aircraft DTE address.

6.6.3.2.2 Expedited subnetwork connection establishment

An aircraft LME initiating expedited subnetwork connection establishment shall implement this clause. The aircraft LME shall invoke the procedures described in clause 3.4.4.12 when connecting to a ground LME indicating support for expedited subnetwork connection procedures. The aircraft DTE shall reissue `CALL REQUEST`s for those logical channels for which responses (i.e. either a `CALL CONFIRMATION` or a `CLEAR REQUEST`) were not included in the `XID_RSP_LE`. The ground DCE shall use the Called Line Address Modified Notification facility to inform the aircraft DTE of the ground DTE's X.121 address.

NOTE 1: The `CLEAR CONFIRMATION`, if required, will be transferred in an `INFO` frame.

NOTE 2: The Calling Address field in `CLEAR CONFIRMATION` packet will contain the Aircraft DTE address.

6.6.3.3 Subnetwork connection maintenance

During link establishment a ground DCE shall indicate its available routers in the `ATN Router NETs` parameter and the aircraft LME shall then attempt to maintain all subnetwork connections.

NOTE: For subnetwork connections to be maintained across ground station changes, the LME gives preference in choosing a new ground station to ground stations indicating accessibility to the DTEs to which subnetwork connections already exist.

6.6.3.3.1 Explicit subnetwork connection maintenance

To explicitly request subnetwork connection maintenance to a ground DTE, an aircraft DTE shall send a `CALL REQUEST` packet to the ground DTE with a fast select facility containing a VDL mobile `SNDCF` Call User Data Field indicating a request to maintain `SNDCF` context.

If the ground DTE can accept the call, it shall respond with a `CALL ACCEPTED` packet with a fast select facility containing a VDL mobile `SNDCF` Call User Data field indicating whether the `SNDCF` context was maintained. If the DTE or a DCE is unable to accept the call, it shall send a `CLEAR REQUEST` packet to the aircraft DTE including a diagnostic specifying the cause of failure. The ground DTE shall use the Called Line Address Modified Notification facility to inform the aircraft DTE of the ground DTE's X.121 address.

6.6.3.3.2 Expedited subnetwork connection maintenance

An LME initiating expedited subnetwork connection maintenance shall implement this clause. If both the aircraft and ground LMEs support expedited subnetwork procedures, then the procedures described in clause 3.4.4.12. shall be invoked. The initiating DTE shall reissue CALL REQUESTs for those logical channels for which responses (i.e. a CALL CONFIRMATION or a CLEAR REQUEST) were not included in the XID_RSP_HO. A ground DTE shall set the Calling Address field to its X.121 address. The ground DCE shall use the Called Line Address Modified Notification facility to inform the aircraft DTE of the ground DTE's X.121 address.

NOTE: The CLEAR CONFIRMATION, if required, will be transferred in an INFO frame. How the ground LME obtains the CALL REQUEST packet(s) (in ground-initiated handoffs) is outside the scope of the present document.

6.6.3.3.3 Broadcast subnetwork connection maintenance

In order to set the b_s bit in the XID AVLC Specific Options parameter to 1, an LME shall support this clause. The procedures described in clause 3.4.4.10 shall be invoked for each aircraft that indicates support for broadcast subnetwork procedures. The ground DTE and DCE and aircraft DTE shall assume those subnetwork connection have been maintained per clause 3.4.4.10. If an aircraft DTE cannot accept a call, it shall send a CLEAR REQUEST. If the ground DTE indicated that it maintained the SNDCF context but the aircraft DTE cannot maintain the SNDCF context, it shall send a CALL REQUEST indicating that the SNDCF context is not to be maintained.

NOTE: The CLEAR CONFIRMATION, if required, will be transferred in an INFO frame. How the ground and aircraft LME know how to create the calls with their associated negotiated facilities is outside the scope of the present document.

6.6.4 Error handling

An aircraft DTE or ground DCE shall send a CLEAR REQUEST, RESET REQUEST, or RESTART REQUEST packet only for recovery from a DTE failure. When an aircraft DTE or ground DCE receives a packet with a bad sequence number, it shall transmit a REJECT, as specified in ISO/IEC 8208 [5], clause 13.4.

6.6.5 Acknowledgements

An RR packet shall be generated only when a valid DATA packet is received with a P(s), which closes the acknowledgement window. The aircraft DTE or ground DCE shall transmit an RR packet acknowledging the outstanding packets as soon as it is able.

7 The VDL mobile SubNetwork Dependent Convergence Function (SNDCF)

7.1 Introduction

The VDL mobile SNDCF shall be the standard mobile SNDCF specified in the ATN Manual, except as described below.

7.2 New function

The VDL mobile SNDCF shall support maintaining context (e.g. compression tables) across subnetwork calls. The SNDCF shall use the same context (e.g. compression tables) across all SVCs negotiated to a DTE, when negotiated with the same parameters. The SNDCF shall support at least 2 SVCs sharing a context.

NOTE: Because handoffs can be expected to reorder packets, certain compression algorithms do not lend themselves to use over the VDL. Further, implementers of dictionary-based compression algorithms must be sensitive to the problem of updates arriving on either the old or newly established call.

7.3 Call user data encoding

The Call User Data field shall be as detailed in the ATN Manual, except as modified below.

7.3.1 ISH PDU

The ISH PDU shall be included in both the CALL REQUEST and CALL CONFIRMATION packets.

7.3.2 Maintained/initialized status bit

The fifth bit of the compression technique octet (i.e. the sixth octet of the Call User Data field) shall be the maintained/initialized (M/I) status bit that is used to indicate whether the SNDCF context (e.g. the compression state) was maintained from an old SVC to a new SVC.

7.3.3 Call request

If the calling SNDCF is requesting that the SNDCF context be maintained from an existing call to the new call being established, it shall set the M/I bit to 1; otherwise, the M/I bit shall be set to 0.

7.3.4 Call confirmation

If the called SNDCF has successfully maintained the entire SNDCF context to the new call being established, it shall set the M/I bit to 1; otherwise, the M/I bit shall be set to 0.

8 Link layer test cases

8.1 MAC sublayer test cases

8.1.1 Test of listen before talk MAC (NH)

8.1.1.1 Purpose

To test that the system under test never starts transmission during a channel busy period.

8.1.1.2 Test architecture

The tester has a jammer that on demand will jam the frequency to make a received power to a given value at the antenna of the system under test for a given time. The tester detects the bursts (AVLC frames) when the system under test transmits. Optionally a PCO (PCO5) should be put between MAC sublayer and Data Link sublayer of the system under test in order to block all AV2M_UNITDATA requests and to force an AV2M_UNITDATA request containing an AVLC frame input by the tester.

8.1.1.3 Test scenario

The tester jammer produces several busy periods with power signal of more than -90 dBm at the antenna of the system under test. Each busy period lasts more than 1 millisecond. The system under test shall never start transmission during the busy periods, excluding the first millisecond. This test shall be performed when the system under test has an AVLC frame to transmit or, optionally, when AV2M_UNITDATA requests are input at PCO5.

8.1.2 Test of minimal MAC performance (NH)

8.1.2.1 Purpose

To check that the MAC sublayer conforms to the minimal MAC TM1 parameter.

8.1.2.2 Test architecture

PCO5 is needed.

8.1.2.3 Test scenarios

Inter-access test timing. When the channel is idle, no burst shall be transmitted by the system under test before the TM1 minimum value (0,5) millisecond after an AV2M_UNITDATA request has been issued by the tester on the system under test PCO5.

No more than a single burst transmission shall occur after each AV2M_UNITDATA request.

8.1.3 Test of p-persistent MAC performance on idle channel (CP)

8.1.3.1 Purpose

To check that the MAC sublayer conforms to the standardized MAC protocol on an idle channel.

8.1.3.2 Test architecture

The link emulator and PCO5 are required for this test. The tester detects burst transmissions from the system under test. When the channel is idle, the system under test is the only potential transmitter.

8.1.3.3 Test scenarios

The link emulator establishes a link to the IUT in order to collect MAC parameters (as described in clause 8.2.3).

Inter-access test timing: no burst shall be transmitted by the system before TM1 milliseconds after a single AV2M_UNITDATA request has been issued by the tester on the system under test PCO5. Burst transmissions must occur at an integer multiple of TM1 after the AV2M_UNITDATA request time.

Maximum number of access attempts: A burst shall be transmitted $TM1 \times M1$ milliseconds after the AV2M_UNITDATA request time.

p-persistence: k being an integer smaller than M1, the statistical occurrence of a transmission occurring more than $k \times TM1$ milliseconds after the AV2M_UNITDATA request time shall be $(1 - P)^k$.

Remark: Tolerance intervals are required depending on the number of tests to be performed for statistical sampling.

In the following a tolerance of 5 % for the probabilities has been assumed. The parameters are the default parameters:

- $P=13/256$;
- $M1=135$;
- $TM1=4,5$ ms.

The IUT experiences 1000 AV2M_UNITDATA requests. The expected delay of transmissions after each request is given in table 8.1.

Table 8.1: Expected statistic of persistence delay in idle channel

Time of transmission in number of TM1		1	2	3	4	5	6	7	8
Number of occurrences	max	68	65	62	60	57	55	52	50
	min	33	31	29	27	25	24	22	20
Time of transmission in number of TM1		9	10	11	12	13	14	15	16
Number of occurrences	max	48	46	44	42	40	39	37	35
	min	19	18	16	15	14	13	12	11
Time of transmission in number of TM1		17	18	19	20	21	22	23	24
Number of occurrences	max	34	33	31	30	29	28	26	25
	min	10	9	9	8	7	6	6	5
Time of transmission in number of TM1		25	26	27	28	29	30	31	32
Number of occurrences	max	24	23	22	22	21	20	19	18
	min	5	4	4	3	3	3	2	2
Time of transmission in number of TM1		33	34	35	36	37	38	39	40
Number of occurrences	max	18	17	16	16	15	15	14	13
	min	2	1	1	1	0	0	0	0
Time of transmission in number of TM1		41	42	43	44	45	46	47	48
Number of occurrences	max	13	12	12	12	11	11	10	10
	min	0	0	0	0	0	0	0	0
Time of transmission in number of TM1		41	42	43	44	45	46	47	48
Number of occurrences	max	10	9	9	9	8	8	8	8
	min	0	0	0	0	0	0	0	0
Time of transmission in number of TM1		49	50	51	52	53	54	55	56
Number of occurrences	max	7	7	7	7	6	6	6	6
	min	0	0	0	0	0	0	0	0
Time of transmission in number of TM1		57	58	59	60	61	62	63	64
Number of occurrences	max	6	5	5	5	5	5	5	4
	min	0	0	0	0	0	0	0	0
Time of transmission in number of TM1		65	66	67	68	69	70	71	72
Number of occurrences	max	4	4	4	4	4	4	4	4
	min	0	0	0	0	0	0	0	0
Time of transmission in number of TM1		73	74	75	76	77	78	79	80
Number of occurrences	max	3	3	3	3	3	3	3	3
	min	0	0	0	0	0	0	0	0
Time of transmission in number of TM1		81	82	83	84	85	86	87	88
Number of occurrences	max	3	3	3	3	3	3	3	3
	min	0	0	0	0	0	0	0	0

Time of transmission in number of TM1		89	90	91	92	93	94	95	96
Number of occurrences	max	3	3	3	3	3	2	2	2
	min	0	0	0	0	0	0	0	0

Time of transmission in number of TM1		97	98	99	100	101	102	103	104
Number of occurrences	max	2	2	2	2	2	2	2	2
	min	0	0	0	0	0	0	0	0

Time of transmission in number of TM1		105	106	107	108	109	110	111	112
Number of occurrences	max	2	2	2	2	2	2	2	2
	min	0	0	0	0	0	0	0	0

Time of transmission in number of TM1		113	114	115	116	117	118	119	120
Number of occurrences	max	2	2	2	1	1	1	1	1
	min	0	0	0	0	0	0	0	0

Time of transmission in number of TM1		121	122	123	124	125	126	127	128
Number of occurrences	max	1	1	1	1	1	1	1	1
	min	0	0	0	0	0	0	0	0

Time of transmission in number of TM1		129	130	131	132	133	134	135	> 135
Number of occurrences	max	1	1	1	1	1	1	4	0
	min	0	0	0	0	0	0	0	0

8.1.4 Test of p-persistent MAC performance on busy channel (CP)

8.1.4.1 Purpose

To check that the MAC sublayer conforms to the standardized MAC protocol on a busy channel.

8.1.4.2 Test architecture

The link emulator, PCO5, and jammer are required. The tester jammer operates in on/off mode.

8.1.4.3 Test scenarios

The link emulator recovers the MAC parameters. The on/off jammer is switched on hereafter.

The tester jammer off period shall be smaller than TM1 minimum value but greater than the maximum time to detect that the channel is idle. On periods are greater than the channel busy time maximal value (1) millisecond. During on periods, the power signal is above -90 dBm. An AV2M_UNITDATA request is input at PCO5 at the beginning of an off period.

The system under test shall start burst transmissions just after the on-period.

p-persistence: for k integer smaller than M1, the statistic of a burst transmission from the system under test after the k-th on-period after AVM2M_UNITDATA request shall be $(1 - P)^k$.

Maximum number of access attempts: there should be a burst transmission before the (M1+1)-th on-period after the issue of the AV2M_UNITDATA request.

There should be only one burst transmission per AV2M_UNITDATA request.

The parameters to be used are the default parameters:

- $P=13/256$;
- $M1=135$;
- $TM1=4,5$ ms.

The IUT experiences 1000 AV2M_UNITDATA requests. The expected delay of transmissions after each request is given in table 8.2.

Table 8.2: Expected statistic of persistence delay in busy channel

Transmission just after burst number		1	2	3	4	5	6	7	8
Number of occurrences	max	68	65	62	60	57	55	52	50
	min	33	31	29	27	25	24	22	20
Transmission just after burst number		9	10	11	12	13	14	15	16
Number of occurrences	max	48	46	44	42	40	39	37	35
	min	19	18	16	15	14	13	12	11
Transmission just after burst number		17	18	19	20	21	22	23	24
Number of occurrences	max	34	33	31	30	29	28	26	25
	min	10	9	9	8	7	6	6	5
Transmission just after burst number		25	26	27	28	29	30	31	32
Number of occurrences	max	24	23	22	22	21	20	19	18
	min	5	4	4	3	3	3	2	2
Transmission just after burst number		33	34	35	36	37	38	39	40
Number of occurrences	max	18	17	16	16	15	15	14	13
	min	2	1	1	1	0	0	0	0
Transmission just after burst number		41	42	43	44	45	46	47	48
Number of occurrences	max	13	12	12	12	11	11	10	10
	min	0	0	0	0	0	0	0	0
Transmission just after burst number		41	42	43	44	45	46	47	48
Number of occurrences	max	10	9	9	9	8	8	8	8
	min	0	0	0	0	0	0	0	0
Transmission just after burst number		49	50	51	52	53	54	55	56
Number of occurrences	max	7	7	7	7	6	6	6	6
	min	0	0	0	0	0	0	0	0
Transmission just after burst number		57	58	59	60	61	62	63	64
Number of occurrences	max	6	5	5	5	5	5	5	4
	min	0	0	0	0	0	0	0	0
Transmission just after burst number		65	66	67	68	69	70	71	72
Number of occurrences	max	4	4	4	4	4	4	4	4
	min	0	0	0	0	0	0	0	0

Transmission just after burst number		73	74	75	76	77	78	79	80
Number of occurrences	max	3	3	3	3	3	3	3	3
	min	0	0	0	0	0	0	0	0
Transmission just after burst number		81	82	83	84	85	86	87	88
Number of occurrences	max	3	3	3	3	3	3	3	3
	min	0	0	0	0	0	0	0	0
Transmission just after burst number		89	90	91	92	93	94	95	96
Number of occurrences	max	3	3	3	3	3	2	2	2
	min	0	0	0	0	0	0	0	0
Transmission just after burst number		97	98	99	100	101	102	103	104
Number of occurrences	max	2	2	2	2	2	2	2	2
	min	0	0	0	0	0	0	0	0
Transmission just after burst number		105	106	107	108	109	110	111	112
Number of occurrences	max	2	2	2	2	2	2	2	2
	min	0	0	0	0	0	0	0	0
Transmission just after burst number		113	114	115	116	117	118	119	120
Number of occurrences	max	2	2	2	1	1	1	1	1
	min	0	0	0	0	0	0	0	0
Transmission just after burst number		121	122	123	124	125	126	127	128
Number of occurrences	max	1	1	1	1	1	1	1	1
	min	0	0	0	0	0	0	0	0
Transmission just after burst number		129	130	131	132	133	134	135	> 135
Number of occurrences	max	1	1	1	1	1	1	4	0
	min	0	0	0	0	0	0	0	0

8.2 Data link sublayer test cases

8.2.1 Test of maximum time between GSIF transmissions (IT)

8.2.1.1 Purpose

To ensure that the ground IUT idle periods do not exceed the maximum value of TG3.

8.2.1.2 Test architecture

A tester receiver tuned on any given VDL mode 2 frequency, no frames are transmitted to the IUT ground station.

8.2.1.3 Test scenario

On a given frequency no frame is transmitted to the IUT. The IUT ground station shall transmit valid GSIFs (Ground Station Identification Frames) and the period between two consecutive GSIF transmissions shall not exceed 120 seconds.

8.2.2 Test of link establishment (IT)

8.2.2.1 Purpose

To check that the IUT establishes link on demand.

8.2.2.2 Test architecture

A link emulator tester with receiver and transmitter ability. No other link established with the IUT.

8.2.2.3 Test scenario

After having started the ground IUT, the IUT shall transmit a GSIF before 120 seconds. An arbitrary airborne DLS address is sent to the link emulator. The tester catches the IUT DLS address in GSIF. The link emulator transmits a `XID_CMD_HO` with DLS address equal to the DLS address of the ground IUT and the minimal set of mandatory parameters as per table 5-46a in ICAO, annex 10 [1].

Within 10 seconds, the IUT shall respond with a valid `XID_RSP_HO` with destination DLS address equal to the DLS address of the link emulator and source address the IUT DLS address.

8.2.3 Test of IUT link parameters recovery (CP)

8.2.3.1 Purpose

To ensure that the IUT correctly transmits its link parameters during link establishment.

8.2.3.2 Test architecture

A link emulator with receive and transmit ability. No other link established with the IUT.

Test scenario

After having started the ground IUT, the IUT shall transmit a GSIF within 120 seconds. An arbitrary airborne DLS address is sent to the link emulator. The tester catches the IUT DLS address in GSIF. The link emulator transmits a `XID_CMD_HO` with DLS address equal to the DLS address of the ground IUT and the minimal set of mandatory parameters as per table 5-46a in ICAO, annex 10 [1].

The IUT shall respond with a valid `XID_RSP_HO` with destination DLS address equal to the DLS address of the link emulator and source address equal to the IUT DLS address. The `XID_RSP_HO` contains the non-default values of the MAC private parameters:

- MAC persistence P, in GI-PI field identified by F0h 43h;
- parameter M1, in GI-PI field identified by F0h 44h;
- parameter TM2, in GI-PI field identified by F0h 45h.

HDLC public parameters:

- HDLC option, in GI-PI field identified by 80h 03h;
- parameter N1, in GI-PI field identified by 80h 05h;
- parameter k, in GI-PI field identified by F0h 45h;
- parameters T1min, T1max, T1mult, T1exp, in GI-PI field identified by 80h 09h;
- parameter N2, in GI-PI field identified by 80h 0Ah;
- parameter T2, in GI-PI field identified by 80h 0Bh.

HDLC private parameters:

- parameter T3min, in GI-PI field identified by F0h 47h;
- parameter T4, in GI-PI field identified by F0h 42h;
- parameter TG5, in GI-PI field identified by F0h 46h.

If a parameter field is not present, the value of the parameter is the default value.

In particular, the `XID_RSP_HO` shall have been transmitted less than T2 milliseconds after the `XID_CMD_HO` transmission.

8.2.4 Test of received AVLC frame format (NH)

8.2.4.1 Purpose

To ensure that the IUT rejects invalid AVLC frames on reception.

8.2.4.2 Test architecture

The link emulator and a new PCO (PCO7) is needed between the data link sublayer and sub-network layer in order to monitor the data forwarded to higher level.

8.2.4.3 Test scenario

After having established the link, the tester transmits to the IUT an AVLC frame conveying invalid flags or a wrong check sequence. The IUT must discard the received AVLC frame and generate no response, and no data must be detected at PCO7.

8.2.5 Test of transmitted AVLC frames format (IT)

8.2.5.1 Purpose

To ensure that the IUT transmits AVLC frames with the correct format.

8.2.5.2 Test architecture

The link emulator is used.

8.2.5.3 Test scenario

The tester establishes a link with the IUT. The AVLC frames transmitted by the IUT must have their bit 1 in octets 1, 2, 3, 5, 6 and 7 set at 0. Bit 1 in octets 4 and 8 shall be set to 1. The A/G bit (bit 2 in octet 1) must be set to 1 (the IUT is a ground station).

8.2.6 Test of retransmission procedure of unacknowledged frames other than XID (CP)

8.2.6.1 Purpose

To check that the retransmission of INFO, RR (P=1), SREJ (P=1) and FRMR frames conforms to standardized timing.

8.2.6.2 Test architecture

The link emulator and new PCOs: PCO6 for forcing the IUT to transmit command frames, and PCO8 for collecting or imposing the value of the channel utilization parameter `u`.

8.2.6.3 Test scenario

The tester emulates the airborne DLE during a certain time, collects DL parameters and imposes via PCO9 a value for u between 0 and 1 (for example $u=0$). The quantity $x=T1_{mult} \times TD99 \times T1_{exp}^n$ is computed and $x_m=\min(x, T1_{max})$.

When at time t the tester receives an INFO, or a RR ($P=1$), or a SREJ ($P=1$), or a FRMR, the link emulator is switched off and the tester never acknowledges this frame.

The IUT must retransmit the unacknowledged frame $N2-1$ times and the period between the $n-1$ -th and the n -th retransmission must be greater than $T1_{min} + 2TD99$ and smaller than $T1_{min} + 2TD99 + x_m$. For all $y < x_m$ the probability that the period between the $n-1$ -th and n -th retransmission is smaller than $T1_{min} + 2TD99 + y$ shall be equal to y/x .

In Default parameters, $u=0$, 1 000 tests.

Table 8.3: Expected statistic of the delay of the 1st retransmission ($u=0$)

1 st retransmission at time $t+2\ 215$ ms after 1 st transmission	Number of occurrences	
	minimum	maximum
0 < t < 500	529	606
500 < t < 1 000	394	471
1 000 < t < 1 500	0	0
1 500 < t < 2 000	0	0
2 000 < t < 2 500	0	0
2 500 < t < 3 000	0	0
3 000 < t < 3 500	0	0
3 500 < t < 4 000	0	0
4 000 < t < 4 500	0	0
4 500 < t < 5 000	0	0
5 000 < t < 5 500	0	0
5 500 < t < 6 000	0	0
6 000 < t < 6 500	0	0
6 500 < t < 7 000	0	0
7 000 < t < 7 500	0	0
7 500 < t < 8 000	0	0
8 000 < t < 8 500	0	0
8 500 < t < 9 000	0	0
9 000 < t < 9 500	0	0
9 500 < t < 10 000	0	0
10 000 < t < 10 500	0	0
10 500 < t < 11 000	0	0
11 000 < t < 11 500	0	0
11 500 < t < 12 000	0	0
12 000 < t < 12 500	0	0
12 500 < t < 13 000	0	0
13 000 < t < 13 500	0	0
t > 13 500	0	0

Table 8.4: Expected statistic of the delay of the 2nd retransmission (u=0)

2 nd retransmission at time t+2 215 ms after 1 st retransmission	Number of occurrences	
	minimum	maximum
0 < t < 500	297	371
500 < t < 1 000	297	371
1 000 < t < 1 500	295	369
1 500 < t < 2 000	0	0
2 000 < t < 2 500	0	0
2 500 < t < 3 000	0	0
3 000 < t < 3 500	0	0
3 500 < t < 4 000	0	0
4 000 < t < 4 500	0	0
4 500 < t < 5 000	0	0
5 000 < t < 5 500	0	0
5 500 < t < 6 000	0	0
6 000 < t < 6 500	0	0
6 500 < t < 7 000	0	0
7 000 < t < 7 500	0	0
7 500 < t < 8 000	0	0
8 000 < t < 8 500	0	0
8 500 < t < 9 000	0	0
9 000 < t < 9 500	0	0
9 500 < t < 10 000	0	0
10 000 < t < 10 500	0	0
10 500 < t < 11 000	0	0
11 000 < t < 11 500	0	0
11 500 < t < 12 000	0	0
12 000 < t < 12 500	0	0
12 500 < t < 13 000	0	0
13 000 < t < 13 500	0	0
t > 13 500	0	0

Table 8.5: Expected statistic of the delay of the 3rd retransmission ($u=0$)

3 rd retransmission at time $t+2\ 215$ ms after 2 nd retransmission	Number of occurrences	
	minimum	maximum
0 < t < 500	165	228
500 < t < 1 000	165	228
1 000 < t < 1 500	165	228
1 500 < t < 2 000	165	228
2 000 < t < 2 500	165	228
2 500 < t < 3 000	7	29
3 000 < t < 3 500	0	0
3 500 < t < 4 000	0	0
4 000 < t < 4 500	0	0
4 500 < t < 5 000	0	0
5 000 < t < 5 500	0	0
5 500 < t < 6 000	0	0
6 000 < t < 6 500	0	0
6 500 < t < 7 000	0	0
7 000 < t < 7 500	0	0
7 500 < t < 8 000	0	0
8 000 < t < 8 500	0	0
8 500 < t < 9 000	0	0
9 000 < t < 9 500	0	0
9 500 < t < 10 000	0	0
10 000 < t < 10 500	0	0
10 500 < t < 11 000	0	0
11 000 < t < 11 500	0	0
11 500 < t < 12 000	0	0
12 000 < t < 12 500	0	0
12 500 < t < 13 000	0	0
13 000 < t < 13 500	0	0
t > 13 500	0	0

Table 8.6: Expected statistic of the delay of the 4th retransmission (u=0)

4 th retransmission at time t+2 215 ms after 3 rd retransmission	Number of occurrences	
	minimum	maximum
0 < t < 500	90	141
500 < t < 1 000	90	141
1 000 < t < 1 500	90	141
1 500 < t < 2 000	90	141
2 000 < t < 2 500	90	141
2 500 < t < 3 000	90	141
3 000 < t < 3 500	90	141
3 500 < t < 4 000	90	141
4 000 < t < 4 500	55	97
4 500 < t < 5 000	0	0
5 000 < t < 5 500	0	0
5 500 < t < 6 000	0	0
6 000 < t < 6 500	0	0
6 500 < t < 7 000	0	0
7 000 < t < 7 500	0	0
7 500 < t < 8 000	0	0
8 000 < t < 8 500	0	0
8 500 < t < 9 000	0	0
9 000 < t < 9 500	0	0
9 500 < t < 10 000	0	0
10 000 < t < 10 500	0	0
10 500 < t < 11 000	0	0
11 000 < t < 11 500	0	0
11 500 < t < 12 000	0	0
12 000 < t < 12 500	0	0
12 500 < t < 13 000	0	0
13 000 < t < 13 500	0	0
t > 13 500	0	0

Table 8.7: Expected statistic of the delay of the 5th retransmission ($u=0$)

5 th retransmission at time $t+2\ 215$ ms after 4 th retransmission	Number of occurrences	
	minimum	maximum
0 < t < 500	48	88
500 < t < 1 000	48	88
1 000 < t < 1 500	48	88
1 500 < t < 2 000	48	88
2 000 < t < 2 500	48	88
2 500 < t < 3 000	48	88
3 000 < t < 3 500	48	88
3 500 < t < 4 000	48	88
4 000 < t < 4 500	48	88
4 500 < t < 5 000	48	88
5 000 < t < 5 500	48	88
5 500 < t < 6 000	48	88
6 000 < t < 6 500	48	88
6 500 < t < 7 000	48	88
7 000 < t < 7 500	31	66
7 500 < t < 8 000	0	0
8 000 < t < 8 500	0	0
8 500 < t < 9 000	0	0
9 000 < t < 9 500	0	0
9 500 < t < 10 000	0	0
10 000 < t < 10 500	0	0
10 500 < t < 11 000	0	0
11 000 < t < 11 500	0	0
11 500 < t < 12 000	0	0
12 000 < t < 12 500	0	0
12 500 < t < 13 000	0	0
13 000 < t < 13 500	0	0
t > 13 500	0	0

Table 8.8: Expected statistic of the delay of the 6th retransmission ($u=0$)

6 th retransmission at time $t+2\ 215$ ms after 5 th retransmission	Number of occurrences	
	minimum	maximum
0 < t < 500	24	56
500 < t < 1 000	24	56
1 000 < t < 1 500	24	56
1 500 < t < 2 000	24	56
2 000 < t < 2 500	24	56
2 500 < t < 3 000	24	56
3 000 < t < 3 500	24	56
3 500 < t < 4 000	24	56
4 000 < t < 4 500	24	56
4 500 < t < 5 000	24	56
5 000 < t < 5 500	24	56
5 500 < t < 6 000	24	56
6 000 < t < 6 500	24	56
6 500 < t < 7 000	24	56
7 000 < t < 7 500	24	56
7 500 < t < 8 000	24	56
8 000 < t < 8 500	24	56
8 500 < t < 9 000	24	56
9 000 < t < 9 500	24	56
9 500 < t < 10 000	24	56
10 000 < t < 10 500	24	56
10 500 < t < 11 000	24	56
11 000 < t < 11 500	24	56
11 500 < t < 12 000	24	56
12 000 < t < 12 500	24	56
12 500 < t < 13 000	0	3
13 000 < t < 13 500	0	0
t > 13 500	0	0

The same test but with imposed value of u equal to 0,9.

Table 8.9: Expected statistic of the delay of the 1st retransmission ($u=0,9$)

1 st retransmission at time $t+2\ 215$ ms after 1 st transmission	Number of occurrences	
	minimum	maximum
0 < t < 500	38	75
500 < t < 1 000	38	75
1 000 < t < 1 500	38	75
1 500 < t < 2 000	38	75
2 000 < t < 2 500	38	75
2 500 < t < 3 000	38	75
3 000 < t < 3 500	38	75
3 500 < t < 4 000	38	75
4 000 < t < 4 500	38	75
4 500 < t < 5 000	38	75
5 000 < t < 5 500	38	75
5 500 < t < 6 000	38	75
6 000 < t < 6 500	38	75
6 500 < t < 7 000	38	75
7 000 < t < 7 500	38	75
7 500 < t < 8 000	38	75
8 000 < t < 8 500	20	50
8 500 < t < 9 000	0	0
9 000 < t < 9 500	0	0
9 500 < t < 10 000	0	0
10 000 < t < 10 500	0	0
10 500 < t < 11 000	0	0
11 000 < t < 11 500	0	0
11 500 < t < 12 000	0	0
12 000 < t < 12 500	0	0
12 500 < t < 13 000	0	0
13 000 < t < 13 500	0	0
t > 13 500	0	0

Table 8.10: Expected statistic of the delay of the 2nd retransmission ($u=0,9$)

2 nd retransmission at time $t+2\ 215$ ms after 1 st retransmission	Number of occurrences	
	minimum	maximum
0 < t < 500	19	48
500 < t < 1 000	19	48
1 000 < t < 1 500	19	48
1 500 < t < 2 000	19	48
2 000 < t < 2 500	19	48
2 500 < t < 3 000	19	48
3 000 < t < 3 500	19	48
3 500 < t < 4 000	19	48
4 000 < t < 4 500	19	48
4 500 < t < 5 000	19	48
5 000 < t < 5 500	19	48
5 500 < t < 6 000	19	48
6 000 < t < 6 500	19	48
6 500 < t < 7 000	19	48
7 000 < t < 7 500	19	48
7 500 < t < 8 000	19	48
8 000 < t < 8 500	19	48
8 500 < t < 9 000	19	48
9 000 < t < 9 500	19	48
9 500 < t < 10 000	19	48
10 000 < t < 10 500	19	48
10 500 < t < 11 000	19	48
11 000 < t < 11 500	19	48
11 500 < t < 12 000	19	48
12 000 < t < 12 500	19	48
12 500 < t < 13 000	19	48
13 000 < t < 13 500	19	48
13 500 < t < 14 000	19	48
14 000 < t < 14 500	19	48
14 500 < t < 15 000	18	46
t > 15 000	0	0

Table 8.11: Expected statistic of the delay of the 3rd retransmission ($u=0,9$)

3 rd retransmission at time $t+2\ 215$ ms after 2 nd retransmission	Number of occurrences	
	minimum	maximum
0 < t < 500	8	31
500 < t < 1 000	8	31
1 000 < t < 1 500	8	31
1 500 < t < 2 000	8	31
2 000 < t < 2 500	8	31
2 500 < t < 3 000	8	31
3 000 < t < 3 500	8	31
3 500 < t < 4 000	8	31
4 000 < t < 4 500	8	31
4 500 < t < 5 000	8	31
5 000 < t < 5 500	8	31
5 500 < t < 6 000	8	31
6 000 < t < 6 500	8	31
6 500 < t < 7 000	8	31
7 000 < t < 7 500	8	31
7 500 < t < 8 000	8	31
8 000 < t < 8 500	8	31
8 500 < t < 9 000	8	31
9 000 < t < 9 500	8	31
9 500 < t < 10 000	8	31
10 000 < t < 10 500	8	31
10 500 < t < 11 000	8	31
11 000 < t < 11 500	8	31
11 500 < t < 12 000	8	31
12 000 < t < 12 500	8	31
12 500 < t < 13 000	8	31
13 000 < t < 13 500	8	31
13 500 < t < 14 000	8	31
14 000 < t < 14 500	8	31
14 500 < t < 15 000	392	469
t > 15 000	0	0

Table 8.12: Expected statistic of the delay of the 4th retransmission ($u=0,9$)

4 th retransmission at time $t+2\ 215$ ms after 3 rd retransmission	Number of occurrences	
	minimum	maximum
0 < t < 500	3	20
500 < t < 1 000	3	20
1 000 < t < 1 500	3	20
1 500 < t < 2 000	3	20
2 000 < t < 2 500	3	20
2 500 < t < 3 000	3	20
3 000 < t < 3 500	3	20
3 500 < t < 4 000	3	20
4 000 < t < 4 500	3	20
4 500 < t < 5 000	3	20
5 000 < t < 5 500	3	20
5 500 < t < 6 000	3	20
6 000 < t < 6 500	3	20
6 500 < t < 7 000	3	20
7 000 < t < 7 500	3	20
7 500 < t < 8 000	3	20
8 000 < t < 8 500	3	20
8 500 < t < 9 000	3	20
9 000 < t < 9 500	3	20
9 500 < t < 10 000	3	20
10 000 < t < 10 500	3	20
10 500 < t < 11 000	3	20
11 000 < t < 11 500	3	20
11 500 < t < 12 000	3	20
12 000 < t < 12 500	3	20
12 500 < t < 13 000	3	20
13 000 < t < 13 500	3	20
13 500 < t < 14 000	3	20
14 000 < t < 14 500	3	20
14 500 < t < 15 000	628	702
t > 15 000	0	0

Table 8.13: Expected statistic of the delay of the 5th retransmission ($u=0,9$)

5 th retransmission at time $t+2\ 215$ ms after 4 th retransmission	Number of occurrences	
	minimum	maximum
$0 < t < 500$	0	14
$500 < t < 1\ 000$	0	14
$1\ 000 < t < 1\ 500$	0	14
$1\ 500 < t < 2\ 000$	0	14
$2\ 000 < t < 2\ 500$	0	14
$2\ 500 < t < 3\ 000$	0	14
$3\ 000 < t < 3\ 500$	0	14
$3\ 500 < t < 4\ 000$	0	14
$4\ 000 < t < 4\ 500$	0	14
$4\ 500 < t < 5\ 000$	0	14
$5\ 000 < t < 5\ 500$	0	14
$5\ 500 < t < 6\ 000$	0	14
$6\ 000 < t < 6\ 500$	0	14
$6\ 500 < t < 7\ 000$	0	14
$7\ 000 < t < 7\ 500$	0	14
$7\ 500 < t < 8\ 000$	0	14
$8\ 000 < t < 8\ 500$	0	14
$8\ 500 < t < 9\ 000$	0	14
$9\ 000 < t < 9\ 500$	0	14
$9\ 500 < t < 10\ 000$	0	14
$10\ 000 < t < 10\ 500$	0	14
$10\ 500 < t < 11\ 000$	0	14
$11\ 000 < t < 11\ 500$	0	14
$11\ 500 < t < 12\ 000$	0	14
$12\ 000 < t < 12\ 500$	0	14
$12\ 500 < t < 13\ 000$	0	14
$13\ 000 < t < 13\ 500$	0	14
$13\ 500 < t < 14\ 000$	0	14
$14\ 000 < t < 14\ 500$	0	14
$14\ 500 < t < 15\ 000$	772	834
$t > 15\ 000$	0	0

Table 8.14: Expected statistic of the delay of the 6th retransmission (u=0,9)

6 th retransmission at time t+2 215 ms after 5 th retransmission	Number of occurrences	
	minimum	maximum
0 < t < 500	0	9
500 < t < 1 000	0	9
1 000 < t < 1 500	0	9
1 500 < t < 2 000	0	9
2 000 < t < 2 500	0	9
2 500 < t < 3 000	0	9
3 000 < t < 3 500	0	9
3 500 < t < 4 000	0	9
4 000 < t < 4 500	0	9
4 500 < t < 5 000	0	9
5 000 < t < 5 500	0	9
5 500 < t < 6 000	0	9
6 000 < t < 6 500	0	9
6 500 < t < 7 000	0	9
7 000 < t < 7 500	0	9
7 500 < t < 8 000	0	9
8 000 < t < 8 500	0	9
8 500 < t < 9 000	0	9
9 000 < t < 9 500	0	9
9 500 < t < 10 000	0	9
10 000 < t < 10 500	0	9
10 500 < t < 11 000	0	9
11 000 < t < 11 500	0	9
11 500 < t < 12 000	0	9
12 000 < t < 12 500	0	9
12 500 < t < 13 000	0	9
13 000 < t < 13 500	0	9
13 500 < t < 14 000	0	9
14 000 < t < 14 500	0	9
14 500 < t < 15 000	859	909
t > 15 000	0	0

8.2.7 Test of maximum window size (NH)

8.2.7.1 Purpose

To ensure that no more than 7 (seven) INFO unacknowledged frames are transmitted.

8.2.7.2 Test architecture

The airborne DLE emulator [possibly PCO6].

8.2.7.3 Test scenario

The tester emulates the airborne DLE to establish a link with the IUT during a certain time and is switched off, no more INFO frame is acknowledged. The IUT shall not transmit no more than 7 (seven) sequentially numbered unacknowledged INFO frames.

8.2.8 Test of window size (CP)

8.2.8.1 Purpose

To ensure that no more than k INFO unacknowledged frames are transmitted.

8.2.8.2 Test architecture

The airborne DLE emulator [possibly PCO6].

8.2.8.3 Test scenario

The tester collects the value of parameter k (window size) after link establishment. The link with the IUT is maintained during a certain time and is switched off, no more INFO frame is acknowledged. The IUT shall transmit no more than k sequentially numbered unacknowledged INFO frames.

8.2.9 Test of maximum acknowledgement delay (IT)

8.2.9.1 Purpose

To ensure that the IUT acknowledges frames (other than XID) in less than maximum T1 value.

8.2.9.2 Test architecture

DLE emulator.

8.2.9.3 Test scenario

The tester emulates the airborne DLE to establish a link with the IUT. The tester sends to IUT a frame (with address destination of the IUT DLE obtained in the emulation and the source address the emulated airborne DLE). The frame must be other than an XID and must require an acknowledgement (for example an INFO, RR (P=1), SREJ (P=1), or FMR). The IUT must send an acknowledgement frame for this frame less than 10 seconds after the frame transmission.

8.2.10 Test of acknowledgement delay (CP)

8.2.10.1 Purpose

To ensure that the IUT acknowledges frames (other than XID) in time.

8.2.10.2 Test architecture

DLE link emulator.

8.2.10.3 Test scenario

The tester collects the value of parameter T2 during link establishment. The tester maintains the link with the IUT. The tester sends to IUT a frame (with address destination of the IUT DLE obtained in the emulation and the source address equal to the emulated airborne DLE). The frame must be other than an XID and must require an acknowledgement (for example an INFO, RR (P=1), SREJ (P=1), or FMR). The IUT must send an acknowledgement frame for this frame less than T2 after the frame transmission.

8.2.11 Test of retransmission procedure of unacknowledged XID (CP)

8.2.11.1 Purpose

To check that the retransmission of XID frames conforms to standardized timing.

8.2.11.2 Test architecture

The airborne DLE emulator, PCO6, PCO8.

8.2.11.3 Test scenario

The tester emulates the airborne link during a certain time, collects DL parameters and imposes via PCO8 a value for u between 0 and 1 (for example $u=0$). The quantity $x=T1_{mult} \times TD99 \times T1_{exp}^n$ is computed and $x_{m}=\min(x, T1_{max})$.

When at time t , via PCO6, the tester makes the IUT DLE transmit an XID command to the emulated airborne DLE, the airborne DLE emulator is switched off and the tester never acknowledges this frame.

The IUT must retransmit the unacknowledged XID frame $N2-1$ times and for integer, $n < N2$, the period between the $n-1$ -th and the n -th retransmission must be greater than $T3_{min} + 2TD99$ and smaller than $T3_{min} + 2TD99 + x_m$. For all $y < x_m$ the probability that the period between the $n-1$ -th and n -th retransmission is smaller than $T3_{min} + 2TD99 + y$ shall be equal to y/x .

In the following tables are displayed the expected statistic of delay retransmission over 1 000 tests with default parameters and $u=0$.

Table 8.15: Expected statistic of the delay of the 1st XID retransmission ($u=0$)

1 st retransmission at time $t+7\ 215$ ms after 1 st transmission	Number of occurrences	
	minimum	maximum
0 < t < 500	529	606
500 < t < 1 000	394	471
1 000 < t < 1 500	0	0
1 500 < t < 2 000	0	0
2 000 < t < 2 500	0	0
2 500 < t < 3 000	0	0
3 000 < t < 3 500	0	0
3 500 < t < 4 000	0	0
4 000 < t < 4 500	0	0
4 500 < t < 5 000	0	0
5 000 < t < 5 500	0	0
5 500 < t < 6 000	0	0
6 000 < t < 6 500	0	0
6 500 < t < 7 000	0	0
7 000 < t < 7 500	0	0
7 500 < t < 8 000	0	0
8 000 < t < 8 500	0	0
8 500 < t < 9 000	0	0
9 000 < t < 9 500	0	0
9 500 < t < 10 000	0	0
10 000 < t < 10 500	0	0
10 500 < t < 11 000	0	0
11 000 < t < 11 500	0	0
11 500 < t < 12 000	0	0
12 000 < t < 12 500	0	0
12 500 < t < 13 000	0	0
13 000 < t < 13 500	0	0
t > 13 500	0	0

Table 8.16: Expected statistic of the delay of the 2nd XID retransmission (u=0)

2 nd retransmission at time t+7 215 ms after 1 st retransmission	Number of occurrences	
	minimum	maximum
0 < t < 500	297	371
500 < t < 1 000	297	371
1 000 < t < 1 500	295	369
1 500 < t < 2 000	0	0
2 000 < t < 2 500	0	0
2 500 < t < 3 000	0	0
3 000 < t < 3 500	0	0
3 500 < t < 4 000	0	0
4 000 < t < 4 500	0	0
4 500 < t < 5 000	0	0
5 000 < t < 5 500	0	0
5 500 < t < 6 000	0	0
6 000 < t < 6 500	0	0
6 500 < t < 7 000	0	0
7 000 < t < 7 500	0	0
7 500 < t < 8 000	0	0
8 000 < t < 8 500	0	0
8 500 < t < 9 000	0	0
9 000 < t < 9 500	0	0
9 500 < t < 10 000	0	0
10 000 < t < 10 500	0	0
10 500 < t < 11 000	0	0
11 000 < t < 11 500	0	0
11 500 < t < 12 000	0	0
12 000 < t < 12 500	0	0
12 500 < t < 13 000	0	0
13 000 < t < 13 500	0	0
t > 13 500	0	0

Table 8.17: Expected statistic of the delay of the 3rd XID retransmission (u=0)

3 rd retransmission at time t+7 215 ms after 2 nd retransmission	Number of occurrences	
	minimum	maximum
0 < t < 500	165	228
500 < t < 1 000	165	228
1 000 < t < 1 500	165	228
1 500 < t < 2 000	165	228
2 000 < t < 2 500	165	228
2 500 < t < 3 000	7	29
3 000 < t < 3 500	0	0
3 500 < t < 4 000	0	0
4 000 < t < 4 500	0	0
4 500 < t < 5 000	0	0
5 000 < t < 5 500	0	0
5 500 < t < 6 000	0	0
6 000 < t < 6 500	0	0
6 500 < t < 7 000	0	0
7 000 < t < 7 500	0	0
7 500 < t < 8 000	0	0
8 000 < t < 8 500	0	0
8 500 < t < 9 000	0	0
9 000 < t < 9 500	0	0
9 500 < t < 10 000	0	0
10 000 < t < 10 500	0	0
10 500 < t < 11 000	0	0
11 000 < t < 11 500	0	0
11 500 < t < 12 000	0	0
12 000 < t < 12 500	0	0
12 500 < t < 13 000	0	0
13 000 < t < 13 500	0	0
t > 13 500	0	0

Table 8.18: Expected statistic of the delay of the 4th XID retransmission ($u=0$)

4 th retransmission at time $t+7\ 215$ ms after 3 rd retransmission	Number of occurrences	
	minimum	maximum
0 < t < 500	90	141
500 < t < 1 000	90	141
1 000 < t < 1 500	90	141
1 500 < t < 2 000	90	141
2 000 < t < 2 500	90	141
2 500 < t < 3 000	90	141
3 000 < t < 3 500	90	141
3 500 < t < 4 000	90	141
4 000 < t < 4 500	55	97
4 500 < t < 5 000	0	0
5 000 < t < 5 500	0	0
5 500 < t < 6 000	0	0
6 000 < t < 6 500	0	0
6 500 < t < 7 000	0	0
7 000 < t < 7 500	0	0
7 500 < t < 8 000	0	0
8 000 < t < 8 500	0	0
8 500 < t < 9 000	0	0
9 000 < t < 9 500	0	0
9 500 < t < 10 000	0	0
10 000 < t < 10 500	0	0
10 500 < t < 11 000	0	0
11 000 < t < 11 500	0	0
11 500 < t < 12 000	0	0
12 000 < t < 12 500	0	0
12 500 < t < 13 000	0	0
13 000 < t < 13 500	0	0
t > 13 500	0	0

Table 8.19: Expected statistic of the delay of the 5th XID retransmission ($u=0$)

5 th retransmission at time $t+7\ 215$ ms after 4 th retransmission	Number of occurrences	
	minimum	maximum
0 < t < 500	48	88
500 < t < 1 000	48	88
1 000 < t < 1 500	48	88
1 500 < t < 2 000	48	88
2 000 < t < 2 500	48	88
2 500 < t < 3 000	48	88
3 000 < t < 3 500	48	88
3 500 < t < 4 000	48	88
4 000 < t < 4 500	48	88
4 500 < t < 5 000	48	88
5 000 < t < 5 500	48	88
5 500 < t < 6 000	48	88
6 000 < t < 6 500	48	88
6 500 < t < 7 000	48	88
7 000 < t < 7 500	31	66
7 500 < t < 8 000	0	0
8 000 < t < 8 500	0	0
8 500 < t < 9 000	0	0
9 000 < t < 9 500	0	0
9 500 < t < 10 000	0	0
10 000 < t < 10 500	0	0
10 500 < t < 11 000	0	0
11 000 < t < 11 500	0	0
11 500 < t < 12 000	0	0
12 000 < t < 12 500	0	0
12 500 < t < 13 000	0	0
13 000 < t < 13 500	0	0
t > 13 500	0	0

Table 8.20: Expected statistic of the delay of the 6th XID retransmission (u=0)

6 th retransmission at time t+7 215 ms after 5 th retransmission	Number of occurrences	
	minimum	maximum
0 < t < 500	24	56
500 < t < 1 000	24	56
1 000 < t < 1 500	24	56
1 500 < t < 2 000	24	56
2 000 < t < 2 500	24	56
2 500 < t < 3 000	24	56
3 000 < t < 3 500	24	56
3 500 < t < 4 000	24	56
4 000 < t < 4 500	24	56
4 500 < t < 5 000	24	56
5 000 < t < 5 500	24	56
5 500 < t < 6 000	24	56
6 000 < t < 6 500	24	56
6 500 < t < 7 000	24	56
7 000 < t < 7 500	24	56
7 500 < t < 8 000	24	56
8 000 < t < 8 500	24	56
8 500 < t < 9 000	24	56
9 000 < t < 9 500	24	56
9 500 < t < 10 000	24	56
10 000 < t < 10 500	24	56
10 500 < t < 11 000	24	56
11 000 < t < 11 500	24	56
11 500 < t < 12 000	24	56
12 000 < t < 12 500	24	56
12 500 < t < 13 000	0	3
13 000 < t < 13 500	0	0
t > 13 500	0	0

8.2.12 Test of minimal link monitoring (IT)

8.2.12.1 Purpose

To ensure that the IUT monitors the link.

8.2.12.2 Test architecture

The airborne DLE emulator.

8.2.12.3 Test scenario

The tester emulates the airborne DLE to establish a link with the IUT during a certain time and is switched off at time t without any non-acknowledged frame pending either on emulated DLE or on IUT DLE. The IUT shall send a frame with DLS destination address the DLS address of the airborne DLE emulator (an RR in ABM, a SREJ in SRM and a FRMR in FRM) before time t+1 442 min.

Optionally one can test that after the last frame transmission the IUT enters in site recovery procedure.

8.2.13 Test of link monitoring (CP)

8.2.13.1 Purpose

To ensure that the IUT monitors the link with standardized timing.

8.2.13.2 Test architecture

The airborne DLE emulator.

8.2.13.3 Test scenario

The tester recovers the value of T4 parameter during link establishment and maintains the link with the IUT during a certain time. The link emulator is switched off at time t without any non-acknowledged frame pending on emulated DLE and IUT DLE. The IUT shall send a frame with DLS destination address equal to the DLS address of the airborne DLE emulator (an RR in ABM, a SREJ in SRM and a FRMR in FRM) before time $t+T4$.

8.2.14 Test of illegal reception (IT)

8.2.14.1 Purpose

To ensure that the IUT correctly detects illegal frames.

8.2.14.2 Test architecture

Airborne DLE emulator.

8.2.14.3 Test scenario

The tester emulates the airborne DLE and establishes the link with the IUT DLE during a certain time. The emulator is switched off and the tester transmits an illegal frame (as defined in ISO/IEC 13239 [7]) to the IUT with DLS destination address equal to the DLS address of the DLE IUT and as source DLS address the DLS address of the airborne emulator. For example the illegal frame can be:

- a frame containing user data whose length exceeds the maximum information field length;
- an INFO frame such that $N(R)-1$ identifies an INFO frame that has not yet been transmitted by an INFO frame with acknowledge bits $N(R)$ which identifies an INFO frame which has previously been acknowledged by the airborne DLE emulator IUT.

After this transmission the IUT shall response with a FRMR ($P=1$) frame.

8.2.15 Test of time between GSIF transmissions (CP)

8.2.15.1 Purpose

To ensure that the LME IUT transmits GSIFs with standardized periods of timer TG4.

8.2.15.2 Test architecture

Several airborne DLE emulators (with different DLS addresses) and a tester receiver tuned on any given VDL mode 2 frequency.

8.2.15.3 Test scenario

An arbitrary number of airborne emulators being active on any set of frequencies. The tester is tuned to an arbitrary frequency. The tester shall receive GSIFs from the IUT ground station and the period between two consecutive GSIF receptions shall be an integer number of seconds uniformly distributed between 100 s and 120 s.

Table 8.21 gives the expected distribution of GSIF periods over 1 000 GSIF transmissions.

Table 8.21: Expected statistic of GSIF period of transmission

Period between two consecutive GSIF transmissions in second	Number of occurrences	
	minimum	maximum
0	31	65
1	31	65
2	31	65
3	31	65
4	31	65
5	31	65
6	31	65
7	31	65
8	31	65
9	31	65
10	31	65
11	31	65
12	31	65
13	31	65
14	31	65
15	31	65
16	31	65
17	31	65
18	31	65
19	31	65
20	31	65
> 20	0	0

8.2.16 Test of maximal link overlap (IT)

8.2.16.1 Purpose

To ensure that the link overlap during handoff does not last more than the maximum value of TG5.

8.2.16.2 Test architecture

An airborne DLE emulator.

8.2.16.3 Test scenario

The DLE emulator maintains a link with the IUT DLE during a certain time, having set bit "i" to 1 in the AVLC specific options. At a given time it transmits an XID_CMD_HO. After reception of the XID_RSP_HO the DLE-emulator continues to respond to the command frames and acknowledges the INFO frames from the IUT DLE but sends no command. The DLE-emulator shall not receive frames from the IUT DLE 255 s after having received the first XID_RSP_HO.

8.2.17 Test of link hand-off (CP)

8.2.17.1 Purpose

To ensure that the link overlap during handoff exceeds TG5.

8.2.17.2 Test architecture

An airborne DLE emulator.

8.2.17.3 Test scenario

The DLE emulator establishes a link with the IUT and maintains a link with the IUT, having set bit "i" to 1 in the AVLC specific options. It recovers the value of the parameter TG5 of the IUT DLE. Then the tester transmits a `XID_CMD_HO`. After reception of the `XID_RSP_HO` the DLE-emulator continues to respond to the command frames and acknowledges the INFO frames from the IUT DLE but sends no command. The DLE-emulator shall not receive frames from the IUT DLE TG5 seconds after having received the first `XID_RSP_HO`.

8.2.18 Frame collision with tester precedence test

8.2.18.1 Purpose

To ensure that the tester precedence in collision frame resolution is respected.

8.2.18.2 Test architecture

Link emulator.

8.2.18.3 Test scenario

On a given frequency the tester waits for the reception of a GSIF from the ground IUT. The tester extracts the IUT DLS address from the GSIF and sends a lower DLS address to the DLE emulator. The tester establishes a link between the DLE emulator and the ground IUT via the `XID_CMD_LE` and `XID_RSP_LE` exchanges. The DLE emulator sends an illegal frame, i.e. a frame which exceeds the maximum allowed data field length. The ground IUT shall respond with a FRMR with P=1. When the ground FRMR is received the DLE emulator also sends a FRMR with P=1. The DLE emulator having precedence, the ground IUT shall respond with a UA frame acknowledging the emulator FRMR [and shall not retransmit its FRMR frame].

8.2.19 Frame collision with IUT precedence test

8.2.19.1 Purpose

To ensure that the IUT precedence in collision frame resolution is respected.

8.2.19.2 Test architecture

Link emulator.

8.2.19.3 Test scenario

On a given frequency the tester waits for the reception of a GSIF from the ground IUT. The tester extracts the IUT DLS address from the GSIF and sends a higher DLS address to the DLE emulator. The tester establishes a link between the DLE emulator and the ground IUT via the `XID_CMD_LE` and `XID_RSP_LE` exchanges. The DLE emulator sends an illegal frame, i.e. a frame which exceeds the maximum allowed data field length. The ground IUT shall respond with a FRMR with P=1. When the ground FRMR is received the DLE emulator also sends a FRMR with P=1 and the emulator is switched off. The ground IUT having precedence, it shall not respond with a UA frame acknowledging the emulator FRMR and shall retransmit its FRMR frame before $T_{1min} + 2TD + T_{1max}$.

8.2.20 Selective acknowledgement test

8.2.21 Purpose

To ensure that out of order INFO frames are correctly acknowledged.

8.2.22 Test architecture

Link emulator.

8.2.23 Test scenario

The DLE emulator establishes a link with the ground IUT. The DLE emulator sends first an INFO frame (P=1) with N(S)=010 and N(R)=001, just after the DLE emulator sends an INFO frame (P=1) with N(S)=001 and N(R)=001, creating out of order frame reception on the ground IUT. The ground IUT shall respond with a SREJ frame with information field bit 6 to 8 set to 010 and bit 1 set to 1.

8.3 Test summary

Table 8.22: Test list

Test number and description	NH	IT	CP	PCOs
P1: demodulation test		X		PCO1
P2: FEC test		X		PCO2
P3: Silent layer test	X			PCO3
P4: encoding test		X		PCO4
M1: listen before talk test	X			PCO5?
M2: minimal MAC test	X			PCO5
M3: idle channel MAC test			X	PCO5
M4: busy channel MAC test			X	PCO5
D1: minimal GSIF transmission test		X		
D2: link establishment test		X		
D3: parameters recovery test			X	
D4: received AVLC format test	X			PCO7
D5: transmitted AVLC format test		X		
D6: other than XID test			X	PCO6, PCO8
D7: maximum window size test		X		PCO6?
D8: window size test			X	PCO6?
D9: max ack delay test		X		
D10: acknowledgement delay test			X	
D11: XID retransmission test			X	PCO6, PCO8
D12: minimal link monitoring test		X		
D13: link monitoring test			X	
D14: illegal reception test		X		
D15: GSIF transmission test			X	
D16: maximal link overlap test		X		
D17: link hand-off test			X	

8.4 PCO summary

Table 8.23: PCO list

PCO number	PCO location	Tests using PCO
PCO1	Phy-layer before descrambler	P1
PCO2	between Phy and MAC sublayer	P2
PCO3	between Phy and MAC sublayer	P3
PCO4	between Phy and MAC sublayer	P4
PCO5	between MAC and DLC sublayer	M1?, M2
PCO6	between DLC and subnetwork layer	D6, D7?, D8?, D11
PCO7	between DLC and subnetwork layer	D4
PCO8	in LME	D6, D11

Annex A (informative): Bibliography

International Radio Consultative Committee (CCIR) Report 384-3, annex III, Section 3, Method 1 (see Appendix A).

Recommendation for Space Data System Standards Telemetry Channel Coding, by the Consultative Committee for Space Data Systems (see Appendix A).

List of figures

Figure 4.1: VDL SARPS in the ATN/OSI Organization.....	15
Figure 5.1: Link layer architecture	16
Figure 5.2: Sequence of primitives for a successful transmission of an AV2MPDU.....	19
Figure 5.3: Sequence of primitives for an unsuccessful AV2MPDU transmission.....	20
Figure 5.4: State diagram common legend	20
Figure 5.5: LME state machine	21
Figure 5.6: DLE top level state diagram.....	22
Figure 5.7: DLE data transfer (ABM) state diagram.....	23
Figure 5.8: DLE selective reject (SRM) state diagram (sending SREJ).....	24
Figure 5.9: DLE selective reject (SRM) state diagram (receiving SREJ)	24
Figure 5.10: DLE selective reject (FRM) state diagram.....	25
Figure 5.11: DLE termination state diagram	26
Figure 5.12: Link layer frame format	27

List of tables

Table 5.1: MAC service system parameters	17
Table 5.2: Address type field encoding	28
Table 5.3: Broadcast address encoding	29
Table 5.4: AVLC commands and responses.....	29
Table 5.5: Control field formats	29
Table 5.6: Data link service systems parameters.....	30
Table 5.7: HDLC public parameter set identifier	38
Table 5.8: Timer T1 parameter.....	39
Table 5.9: VDL private parameters	39
Table 5.10a: Parameter set identification	39
Table 5.10b: Connection management parameter	40
Table 5.11: Connection management parameter values.....	40
Table 5.12: Abbreviated XID names.....	40
Table 5.13: Signal quality parameter.....	40
Table 5.14: XID sequencing parameter	41
Table 5.15: AVLC specific options parameter	41
Table 5.16: AVLC specific option values	41
Table 5.17: Expedited subnetwork connection parameter.....	42
Table 5.18: LCR cause parameter	42
Table 5.19: Cause code table.....	42
Table 5.20: Modulation support parameter	43
Table 5.21: Modulation scheme and bit rate	43
Table 5.22: Acceptable alternative ground station parameter	44
Table 5.23: Destination airport parameter	44
Table 5.24: Aircraft Location parameter	44
Table 5.25: Aircraft location subfield description.....	44
Table 5.26: Autotune frequency parameter	45
Table 5.27: Replacement ground station list	45
Table 5.28: Timer T4 parameter	45
Table 5.29: MAC persistence parameter	46
Table 5.30: Counter M1 parameter	46
Table 5.31: Timer TM2 parameter	46
Table 5.32: Timer TG5 parameter.....	46
Table 5.33: T3 min parameter.....	46
Table 5.34: Ground station address filter parameter	47

Table 5.35: Broadcast connection (link only).....	47
Table 5.36: Broadcast connection (link and subnetwork).....	47
Table 5.37: Frequency support list.....	48
Table 5.38: Airport coverage indication parameter.....	48
Table 5.39: Nearest airport parameter.....	49
Table 5.40: ATN router NETs parameter.....	49
Table 5.41: Ground-based system mask parameter.....	49
Table 5.42: Timer TG3 parameter.....	49
Table 5.43: Timer TG4 parameter.....	50
Table 5.44: Ground station location parameter.....	50
Table 5.45: VDL management entity system parameters.....	50
Table 5.46: XID parameters(a).....	52
Table 5.47: XID parameters (b).....	54
Table 5.48: XID parameters (c).....	55
Table 6.1: Subnetwork layer service system parameters.....	66
Table 6.2: Facilities supported by the VDL.....	67
Table 6.3: Facilities Not Supported.....	67
Table 8.1: Expected statistic of persistence delay in idle channel.....	72
Table 8.2: Expected statistic of persistence delay in busy channel.....	74
Table 8.3: Expected statistic of the delay of the 1 st retransmission (u=0).....	78
Table 8.4: Expected statistic of the delay of the 2 nd retransmission (u=0).....	79
Table 8.5: Expected statistic of the delay of the 3 rd retransmission (u=0).....	80
Table 8.6: Expected statistic of the delay of the 4 th retransmission (u=0).....	81
Table 8.7: Expected statistic of the delay of the 5 th retransmission (u=0).....	82
Table 8.8: Expected statistic of the delay of the 6 th retransmission (u=0).....	83
Table 8.9: Expected statistic of the delay of the 1 st retransmission (u=0,9).....	84
Table 8.10: Expected statistic of the delay of the 2 nd retransmission (u=0,9).....	85
Table 8.11: Expected statistic of the delay of the 3 rd retransmission (u=0,9).....	86
Table 8.12: Expected statistic of the delay of the 4 th retransmission (u=0,9).....	87
Table 8.13: Expected statistic of the delay of the 5 th retransmission (u=0,9).....	88
Table 8.14: Expected statistic of the delay of the 6 th retransmission (u=0,9).....	89
Table 8.15: Expected statistic of the delay of the 1 st XID retransmission (u=0).....	91
Table 8.16: Expected statistic of the delay of the 2 nd XID retransmission (u=0).....	92
Table 8.17: Expected statistic of the delay of the 3 rd XID retransmission (u=0).....	93
Table 8.18: Expected statistic of the delay of the 4 th XID retransmission (u=0).....	94

Table 8.19: Expected statistic of the delay of the 5 th XID retransmission (u=0).....	95
Table 8.20: Expected statistic of the delay of the 6 th XID retransmission (u=0).....	96
Table 8.21: Expected statistic of GSIF period of transmission	98
Table 8.22: Test list	100
Table 8.23: PCO list	100

History

Document history		
V1.1.1	July 2003	Public Enquiry PE 20031114: 2003-07-16 to 2003-11-14
V1.1.1	January 2004	Vote V 20040326: 2004-01-26 to 2004-03-26
V1.1.1	March 2004	Publication