

Draft **ETSI EN 301 841-1** V1.1.1 (2001-05)

European Standard (Telecommunications series)

**Electromagnetic compatibility
and Radio spectrum Matters (ERM);
VHF air-ground Digital Link (VDL) mode 2
Technical characteristics and methods of measurement
for ground-based equipment;
Part 1: Physical layer**



Reference

DEN/ERM-RP05-015-1

Keywords

aeronautical, radio, testing

ETSI

650 Route des Lucioles
F-06921 Sophia Antipolis Cedex - FRANCE

Tel.: +33 4 92 94 42 00 Fax: +33 4 93 65 47 16

Siret N° 348 623 562 00017 - NAF 742 C
Association à but non lucratif enregistrée à la
Sous-Préfecture de Grasse (06) N° 7803/88

Important notice

Individual copies of the present document can be downloaded from:

<http://www.etsi.org>

The present document may be made available in more than one electronic version or in print. In any case of existing or perceived difference in contents between such versions, the reference version is the Portable Document Format (PDF). In case of dispute, the reference shall be the printing on ETSI printers of the PDF version kept on a specific network drive within ETSI Secretariat.

Users of the present document should be aware that the document may be subject to revision or change of status. Information on the current status of this and other ETSI documents is available at <http://www.etsi.org/tb/status/>

If you find errors in the present document, send your comment to:
editor@etsi.fr

Copyright Notification

No part may be reproduced except as authorized by written permission.
The copyright and the foregoing restriction extend to reproduction in all media.

© European Telecommunications Standards Institute 2001.
All rights reserved.

Contents

Intellectual Property Rights	5
Foreword.....	5
Introduction.....	5
1 Scope.....	6
2 References.....	6
3 Definitions, abbreviations and symbols	7
3.1 Definitions	7
3.1.1 Basic reference model definitions.....	7
3.1.2 Service conventions definitions	8
3.1.3 General Definitions.....	8
3.2 Abbreviations.....	9
4 General architecture of VDL Mode 2	11
5 Physical layer protocols and services functional specifications	12
5.1 Overview	12
5.1.1 Functions.....	12
5.1.2 Data reception by the receiver	12
5.1.3 Data transmission.....	12
5.2 Transmission procedure.....	13
5.3 Modulation scheme	14
5.4 Training sequence	14
5.4.1 RF power rise time definition	14
5.5 Physical layer Service Access Point.....	15
6 VDL MODE 2 equipment requirements	15
6.1 Receiver requirements.....	15
6.1.1 Sensitivity.....	15
6.1.2 First Adjacent Channel Rejection	15
6.1.3 Rejection of signals in the VHF Aeronautical band.....	16
6.1.4 Rejection of signals outside the VHF Aeronautical band	16
6.1.5 Desired signal dynamic range.....	16
6.1.6 Symbol rate capture range.....	16
6.1.7 Frequency capture range	17
6.1.8 Co-channel interference	17
6.1.9 Conducted spurious emission	17
6.1.10 In-band Intermodulation.....	17
6.2 Transmitter requirements.....	17
6.2.1 Protection of the transmitter	18
6.2.2 Manufacturer's declared output power	18
6.2.3 RF power rise time.....	18
6.2.4 RF power release time.....	18
6.2.5 Modulation rate.....	18
6.2.6 Symbol constellation error.....	18
6.2.7 Conducted Spurious emissions	19
6.2.8 Adjacent channel power	19
6.2.9 Wide-band noise	19
6.2.10 Frequency Tolerance.....	19
6.2.11 Cabinet radiation.....	19
6.3 Transceiver timing requirements.....	19
6.3.1 Receiver to transmitter turn-around time.....	19
6.3.2 Transmitter to receiver turn-around time.....	20
7 General requirements	20
7.1 General	20

7.2	Controls and indicators.....	20
7.3	Class of emission and modulation characteristics	20
7.4	Warm up	20
8	Test conditions, power sources and ambient temperatures	20
8.1	Test power source.....	20
8.2	Test channels.....	21
8.3	General conditions of measurement	21
8.3.1	Receiver test signal arrangement	21
8.3.2	Performance check.....	21
8.4	Normal and extreme test conditions	21
8.4.1	Normal test conditions	21
8.4.1.1	Normal temperature and humidity	21
8.4.1.2	Normal power sources	21
8.4.1.2.1	Mains voltage and frequency	21
8.4.1.2.2	Other power sources.....	22
8.4.2	Extreme test conditions	22
8.4.2.1	Extreme temperatures	22
8.4.2.2	Procedure for tests at extreme temperatures.....	22
8.4.2.2.1	General	22
8.4.2.2.2	High temperature.....	22
8.4.2.2.3	Low temperature	22
8.4.2.3	Extreme values of test power sources	22
8.4.2.4	Other power sources	23
8.4.2.5	Performance check	23
9	Detailed Test Procedures for the physical layer	23
9.1	Receiver.....	23
9.1.1	BER test	23
9.1.2	Sensitivity (clause 6.1.1)	24
9.1.3	First Adjacent Channel Rejection (clause 6.1.2).....	25
9.1.4	Rejection of signals within the VHF Aeronautical band (clause 6.1.3)	26
9.1.5	Rejection of signals outside the VHF Aeronautical band (clause 6.1.4).....	26
9.1.6	Desired Signal dynamic range (clause 6.1.5).....	27
9.1.7	Symbol rate capture range (clause 6.1.6).....	28
9.1.8	Frequency capture range (clause 6.1.7).....	28
9.1.10	Co-channel interference (clause 6.1.8).....	29
9.1.11	Conducted spurious emission (clause 6.1.9).....	29
9.1.12	In-band Intermodulation (clause 6.1.10)	30
9.2	Transmitter.....	31
9.2.2	Manufacturer's declared output power (clause 6.2.2).....	31
9.2.3	RF power rise time (clause 6.2.3)	31
9.2.4	RF power release time (clause 6.2.4)	33
9.2.5	Symbol Constellation Error (clause 6.2.6).....	34
9.2.6	Spurious emissions (clause 6.2.7)	34
9.2.7	Adjacent channel power (clause 6.2.8).....	35
9.2.7.1	Method of measurement for the first adjacent channel	35
9.2.7.2	Method of measurement for the second adjacent channel.....	35
9.2.7.3	Method of measurement for the fourth adjacent channel	36
9.2.8	Wideband noise (clause 6.2.9).....	38
9.2.9	Protection of the transmitter(clause 6.2.1).....	38
9.2.9.1	Method of measurement.....	38
9.2.9.2	Requirement	38
9.2.10	Frequency Error (clause 6.2.10).....	39
9.2.10.1	Definition	39
9.2.10.2	Method of measurement.....	39
9.2.10.3	Limits.....	39
9.3	Physical layer, system parameters.....	39
9.3.1	Receiver to Transmitter turn-around time (clause 6.3.1).....	39
9.3.2	Transmitter to Receiver turn-around time (clause 6.3.2).....	40
	History	42

Intellectual Property Rights

IPRs essential or potentially essential to the present document may have been declared to ETSI. The information pertaining to these essential IPRs, if any, is publicly available for **ETSI members and non-members**, and can be found in ETSI SR 000 314: "*Intellectual Property Rights (IPRs); Essential, or potentially Essential, IPRs notified to ETSI in respect of ETSI standards*", which is available from the ETSI Secretariat. Latest updates are available on the ETSI Web server (<http://www.etsi.org/ipr>).

Pursuant to the ETSI IPR Policy, no investigation, including IPR searches, has been carried out by ETSI. No guarantee can be given as to the existence of other IPRs not referenced in ETSI SR 000 314 (or the updates on the ETSI Web server) which are, or may be, or may become, essential to the present document.

Foreword

This European Standard (Telecommunications series) has been produced by ETSI Technical Committee Electromagnetic compatibility and Radio spectrum Matters (ERM), and is now submitted for the Public Enquiry phase of the ETSI standards Two-step Approval Procedure.

The present document is part 1 of a multi-part deliverable covering VHF air-ground Digital Link (VDL) Mode 2; Technical characteristics and methods of measurement for ground-based equipment, as identified below:

Part 1: "Physical layer";

Part 2: "Data link layer".

Proposed national transposition dates	
Date of latest announcement of this EN (doa):	3 months after ETSI publication
Date of latest publication of new National Standard or endorsement of this EN (dop/e):	6 months after doa
Date of withdrawal of any conflicting National Standard (dow):	6 months after doa

Introduction

The present document states the technical specifications for ground-based equipment implementing Very High Frequency (VHF) Digital Link (VDL) Mode 2 air interface, operating in the VHF band (117,975 MHz - 137 MHz) with 25 kHz channel spacing.

Manufacturers should note that in the future, all or part of the frequency band 108,000 MHz to 117,975 MHz may become available for aeronautical communications.

The present document may be used to produce tests for the assessment of the performance of the equipment. The performance of the equipment submitted for type testing should be representative of the performance of the corresponding production model.

The present document has been written on the assumption that:

- the type test measurements will be performed only once, in an accredited test laboratory, and the measurements accepted by the various authorities in order to grant type approval;
- if equipment available on the market is required to be checked it may be tested in accordance with the methods of measurement specified in the present document.

1 Scope

The present document applies to VDL Mode 2 ground-air digital communications using Differential Eight Phase Shift Keying (D8PSK), intended for channel increments of 25 kHz. The VDL Mode 2 system provides data communication exchanges between aircraft and ground-based systems. The scope of the present document is limited to ground-based stations.

The VDL Mode 2 system is designed to be an Ground/Air sub-system of the Aeronautical Telecommunication Network (ATN) using the AM(R)S band and it is organized according to the Open Systems Interconnection (OSI) model (defined by ISO). It shall provide reliable subnetwork services to the ATN system.

This document provides functional specifications for ground-based radio equipment intended to be used for ground-air data communications. The present document is derived from the following documents :

- VDL Mode 2 SARPs version 3.0. ICAO Annex 10 Volume III part I [1].
- ED 92, Minimum Operational Performance Specification For An Airborne VDL Mode 2 Transceiver Operating In The Frequency Range (118-136,975 MHz) Physical Layer, March 2000, which specifies the airborne transceiver.

The present document consists of two parts:

- the first part provides functional specifications and test procedures for physical layer;
- the second part provides functional specifications and test procedures for link and sub-network access layers.

2 References

The following documents contain provisions which, through reference in this text, constitute provisions of the present document.

- References are either specific (identified by date of publication and/or edition number or version number) or non-specific.
- For a specific reference, subsequent revisions do not apply.
- For a non-specific reference, the latest version applies.

- [1] Annex 10 to the Convention on International Civil Aviation, International Civil Aviation Organisation.
- [2] ED 92, Minimum Operational Performance Specification For An Airborne VDL Mode 2 Transceiver Operating In The Frequency Range (118-136,975 MHz) Physical Layer Final Draft, March 2000.
- [3] ISO 3309: "Information technology -- Telecommunications and information exchange between systems -- High-level data link control (HDLC) procedures -- Frame structure".
- [4] ISO 8208: "Information technology -- Data communications -- X.25 Packet Layer Protocol for Data Terminal Equipment".
- [5] ISO 7498-1 (1984): "Information technology -- Open Systems Interconnection -- Basic Reference Model (plus TC1: 1988)".
- [6] ISO 7498-1 ADD (1987): "Open System interconnection – Basic reference model. Addendum 1: Connectionless data transmission
- [7] ISO 7498-1 ADD (1989): "Information technology -- Open Systems Interconnection -- Basic Reference Model. Addendum 1: Naming and addressing".

- [8] ISO TR 10731 (1987): "Information technology -- Open Systems Interconnection -- Basic Reference Model -- Conventions for the definition of OSI services."
- [9] ETR 028: "Radio Equipment and Systems (RES); Uncertainties in the measurement of mobile radio equipment characteristics".
- [10] ITU-T Recommendation P.53: "Psophometer for use on telephone-type circuits".
- [11] "Error Control Coding: Fundamental and Applications," (S. Lin, D. Costello, Prentice Hall, 1983).
- [12] International Radio Consultative Committee (CCIR) Report 384-3, Annex III, Section 3, Method 1.
- [13] Recommendation for Space Data System Standards Telemetry Channel Coding, by the Consultative Committee for Space Data Systems.
- [14] ISO DP 10039: MAC Service Definitions.
- [15] RTCA/DO-224(a) Signal in Space Minimum Aviation System Performance Standards (MASPS) for Advanced VHF Digital Data Communications including Compatibility with Digital Voice Techniques
- [16] ISO13239: "Information technology – Telecommunications and information exchange between systems – High-level data link control (HDLC) procedures – General purpose XID frame information field content and format. Amendment 9: Extension of HDLC sequence number modulus beyond 128".
- [17] EN 300 113-1: "Electromagnetic compatibility and Radio spectrum Matters (ERM); Land mobile service; Radio equipment intended for the transmission of data (and speech) and having an antenna connector; Part 1: Technical characteristics and methods of measurement".
- [18] EN 301 841-2: "Electromagnetic compatibility and Radio spectrum Matters (ERM); VHF Air-Ground Digital Link (VDL) Mode 2 Technical characteristics and methods of measurement for ground-based equipment; Part 2: Data Link Layer".

3 Definitions, abbreviations and symbols

3.1 Definitions

3.1.1 Basic reference model definitions

The present document is based on the concepts developed in the open systems interconnect basic reference model and makes use of the following terms defined in ISO.7498 [5], [6] and [7]:

- layer
- sublayer
- entity
- service
- service access point
- service data unit
- physical layer
- data link layer

3.1.2 Service conventions definitions

The present document makes use of the following terms defined in ISO TR 10731 [8]:

- service provider
- service user
- service primitive
- request
- indication
- confirm

3.1.3 General Definitions

For the purposes of the present document, the following definitions apply:

adjacent channel power: adjacent channel power is the amount of the modulated RF signal power transmitted outside of the assigned channel. Adjacent channel power includes discrete spurious, signal sidebands, and noise density (including phase noise) at the transmitter output

adjacent channel rejection: adjacent channel rejection corresponds to the receiver's ability to demodulate the desired signal and meet the uncorrected BER requirement in the presence of an interfering signal in an adjacent channel. The ratio (in dB) between the adjacent interfering signal level and the desired signal level necessary to achieve the specified minimum uncorrected BER, is the adjacent channel rejection (ACR) ratio

aeronautical mobile service: a mobile service between aeronautical stations and aircraft stations, or between aircraft stations, in which survival craft stations may participate

average transmitter output power: the average power supplied to the antenna transmission line by a transmitter during an interval of time sufficiently long, compared with the lowest frequency encountered in the modulation, taken under normal operating conditions

BER: the bit error rate (BER) is expressed as the ratio between the number of erroneous bits received and the total number of bits received. The uncorrected BER represents the BER without the benefit of Forward Error Correction (FEC)

co-channel interference: the co-channel interference (CCI) protection defines the capability of a receiver to demodulate the desired signal and achieve the minimum specified BER performance in the presence of an unwanted signal at the same assigned channel. The ratio (in dB) between the wanted signal level and the unwanted signal level is the co-channel interference ratio.

conducted measurements: measurements which are made using a direct RF connection to the equipment under test

data rate: mode 2 symbol rate shall be 10 500 symbols/s, with a nominal data rate of 31 500 bits/s

ground base station: aeronautical station equipment, in the aeronautical mobile service, for use with an external antenna and intended for use at a fixed location

interleaver the interleaver creates the AVPL_TIRS sequence made from the block segmentation of the AVLC frame and the RS encoding. To this end one assumes the TIRS matrix made from the RS encoding of the AVLC block segmentation. The TIRS matrix is a matrix of octets made of 255 columns and c rows

spurious emissions: conducted RF emissions on a frequency or frequencies which are outside the necessary bandwidth and the level of which may be reduced without affecting the corresponding transmission of information. Spurious emissions include parasitic emissions, intermodulation products and frequency conversion products

tuning range and channel increments: the transceiver shall be capable of tuning to any of the 760 channels of 25 kHz width from 118 MHz to 136,975 MHz as defined in ICAO International Standards Recommended Practices and Procedures for Air Navigation Services ANNEX 10 Volume 1, part 1.

3.2 Abbreviations

For the purposes of the present document, the following abbreviations apply:

ABM	Asynchronous Balanced Mode
ACK	Acknowledge(ment)
ACR	Adjacent Channel Rejection
ADM	Asynchronous Disconnected Mode
AGC	Automatic Gain Control
AMCP	Aeronautical Mobile Communications Panel
AM(R)S	Aeronautical Mobile (Route) Service
ATN	Aeronautical Telecommunication Network
AVLC	Aviation VHF Link Control
AVLC_LI	Aviation VHF Link Control Length Indicator
AVPL	Aviation VHF Physical Layer
AVPL-Header	AVPL Header and training sequence
AVPL-RBS	AVPL Received Bit de-Scrambled sequence
AVPL-RHeader	AVPL Reception Header
AVPL-RIRS	AVPL Received Interleaved and RS encoded sequence
AVPL-RSS	AVPL Received Symbol de-Segmented sequence
AVPL-TBS	AVPL Transmitted Bit Scrambled sequence
AVPL-THeader	AVPL Transmission Header sequence
AVPL-THI	AVPL Transmitted Header appended and Interleaved sequence
AVPL-TIRS	AVPL Transmitted Interleaved RS encoded sequence
AVPL-TTS	AVPL Transmitted Ternary Symbol sequence
AWG	Arbitrary Waveform Generator
BCD	Binary Coded Decimal
BER	Bit Error Rate
C/R	Command/Response (bit)
CCI	Co Channel Interference
CCIR	International Radio Consultative Committee
CMD	Command (frame)
CSC	Common Signaling Channel
CSMA	Carrier Sense Multiple Access
CW	Continuous Wave
D8PSK	Differentially encoded 8 Phase Shift Keying
dBc	Decibels relative to the carrier
dB _i	Decibels relative to isotropic radiator
D-bit	ISO 8208 delivery bit
dBm	Decibels relative to 1 milliwatt
DCE	Data Circuit-terminating Equipment
DISC	Disconnect (frame)
DLE	Data Link Entity
DLS	Data Link Service
DM	Disconnected Mode (frame)
DTE	Data Terminal Equipment
DXE	Denotes either: Data terminal Equipment <i>or</i> Data circuit-terminating Equipment
EVM	Error Vector Magnitude
FCS	Frame Check Sequence
FEC	Forward Error Correction
FM	Frequency Modulation
FRM	Frame Reject Mode
FRMR	Frame Reject (frame)
GF	Galois Field
GSIF	Ground Station Information Frame
HDLC	High-level Data Link Control
Hex	Hexadecimal
HO	Hand-Off
HTC	Highest Two-way Channel
IA5	The character set defined in ISO 646 table 5
ICAO	International Civil Aviation Organisation

ID	Identification (identifier)
INFO	Information (frame)
IS	Intermediate System
ISH	Intermediate System Hello (packet)
ISO	International Organization for Standardization
ITU-R	International Telecommunication Union - Radiocommunication Sector
LCI	Logical Channel Identifier
LCR	Link Connection Refused
LME	Link Management Entity
Lsb	Least significant bit
LTC	Lowest Two-way Channel
M/I	Maintained/Initialized status bit
MAC	Media Access Control
Msb	Most significant bit
NET	Network Entity Title
nmi	Nautical miles
OSI	Open Systems Interconnection
P/F	Poll/Final (bit)
PDU	Protocol Data Unit
PN	Pseudo Noise
ppm	Parts per million
Q-bit	ISO 8208 Qualifier bit
RF	Radio Frequency
RIRS matrix	Reception de-Interleaver and RS-decoding matrix
RMS	Root Mean Square
RNR	Receive Not Ready (frame)
RR	Receive Ready (frame)
RS	Reed-Solomon
RSP	Response (frame)
SAP	Service Access Point
SARPS	Standards and Recommended Practices (ICAO)
SDL	Specification and Description Language
SDU	Service Data Unit
SINAD	(Signal + Noise + Distortion) / (Noise + Distortion)
SME	System Management Entity
SN	Subnetwork
SNAcP	Subnetwork Access Protocol
SND CF	Subnetwork Dependent Convergence Function
SNPA	Subnetwork Point of Attachment
SNR	Signal to Noise Ratio
SNSAP	Subnetwork Service Access Point
SQP	Signal Quality Parameter
SREJ	Selective Reject (frame)
SRM	Sent selective Reject Mode
SVC	Switched Virtual Circuit
TIRS matrix	Transmission Interleaver and RS encoding matrix
UA	Unnumbered Acknowledgment (frame)
UI	Unnumbered Information (frame)
VDL	VHF Digital Link
VHF	Very High Frequency
VME	VDL Management Entity
VSA	Vector Signal Analyzer
VSWR	Voltage Standing Wave Ratio
XID	Exchange ID (frame)
XOR	Exclusive OR
X 25	ITU-T standard for the protocols and message formats that define the interface between a terminal and a packet switching network

4 General architecture of VDL Mode 2

The general architecture of the VHF radio equipment operating in VDL Mode 2 is depicted in Figure 1. This figure presents the different functional parts of the VDL Mode 2 equipment.

The VDL system is related to the three lower layers of the OSI model providing services described as follows:

Layer 1 (Physical layer): provides transceiver frequency control, bit exchanges over the radio media, and notification functions. These functions are often known as radio and modulation functions. The physical layer handles information exchanges at the lowest level and manipulates bits. The physical layer handles modulation, data encoding and includes a forward error correction mechanism based on interleaving and Reed Solomon coding.

Layer 2 (Link Layer): is split into two sublayers and a link management entity:

- The MAC sublayer provides access to the Physical layer by a CSMA algorithm in charge of channel access. The MAC layer controls channel access and sharing.
- The DLS sublayer is composed of the AVLC derived from the HDLC protocol (ISO 3309 [3]) whose main functions are frame exchanges, frame processing, and error detection.
- The LME controls the link establishment and maintenance between DLS sublayers.

Layer 3: Only the lowest network sublayer of layer 3 (SNAcP) will be described in Part 2. It is compliant with the subnetwork sublayer requirements defined in the ATN SARPs and conforms with the ISO 8208 [4] (or network layer of X.25). It provides packet exchanges over a virtual circuit, error recovery, connection flow control, packet fragmentation, and subnetwork connection management functions.

Layer 2 and 3 is specified in EN 301 841-2 [18].

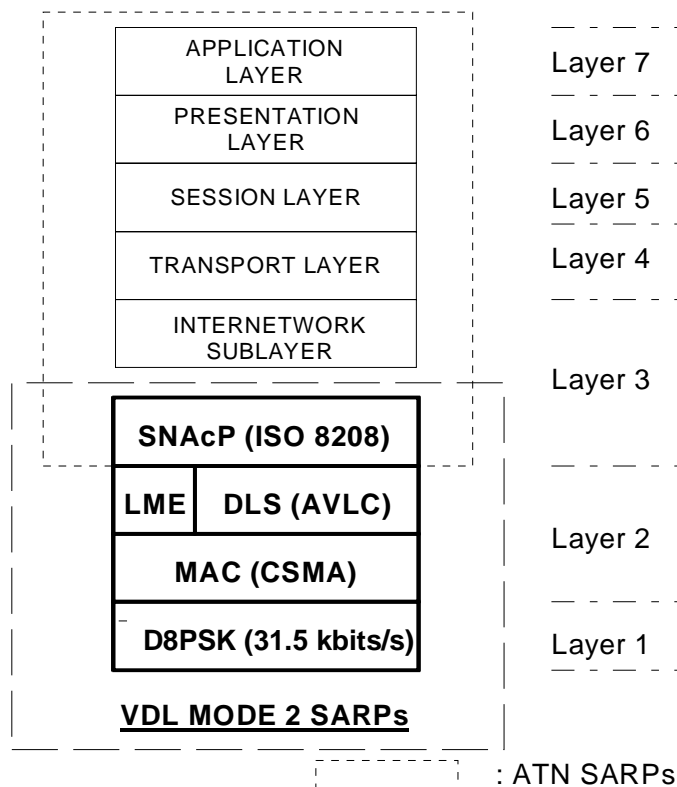

Figure 1: VDL SARPs in the ATN/OSI Organisation

5 Physical layer protocols and services functional specifications

5.1 Overview

The ground stations shall access the physical layer operating in simplex mode.

5.1.1 Functions

The tasks of the physical layer include the following:

- to modulate and demodulate radio carriers with a bit stream of a defined instantaneous rate to create an RF link;
- to acquire and maintain bit and burst synchronization between Transmitters and Receivers;
- to transmit or receive a defined number of bits at a requested time (packet mode) and on a particular carrier frequency;
- to add and remove a training sequence;
- to encode and decode the Forward Error Correction scheme;
- to measure received signal strength;
- to decide whether a channel is idle or busy, for the purposes of managing channel access attempts;
- to offer a notification service about the quality of link.

5.1.2 Data reception by the receiver

The receiver shall decode input signals and forward them to the higher layers for processing.

5.1.3 Data transmission

The VDL physical layer shall appropriately encode the data received from the data link layer and transmit it over the RF channel.

5.2 Transmission procedure

To transmit a sequence of frames, a station shall insert the bit numbers and, compute the FEC, interleave, insert the training sequence, carry out bit scrambling, and finally encode and modulate the RF signal. See figure 2.

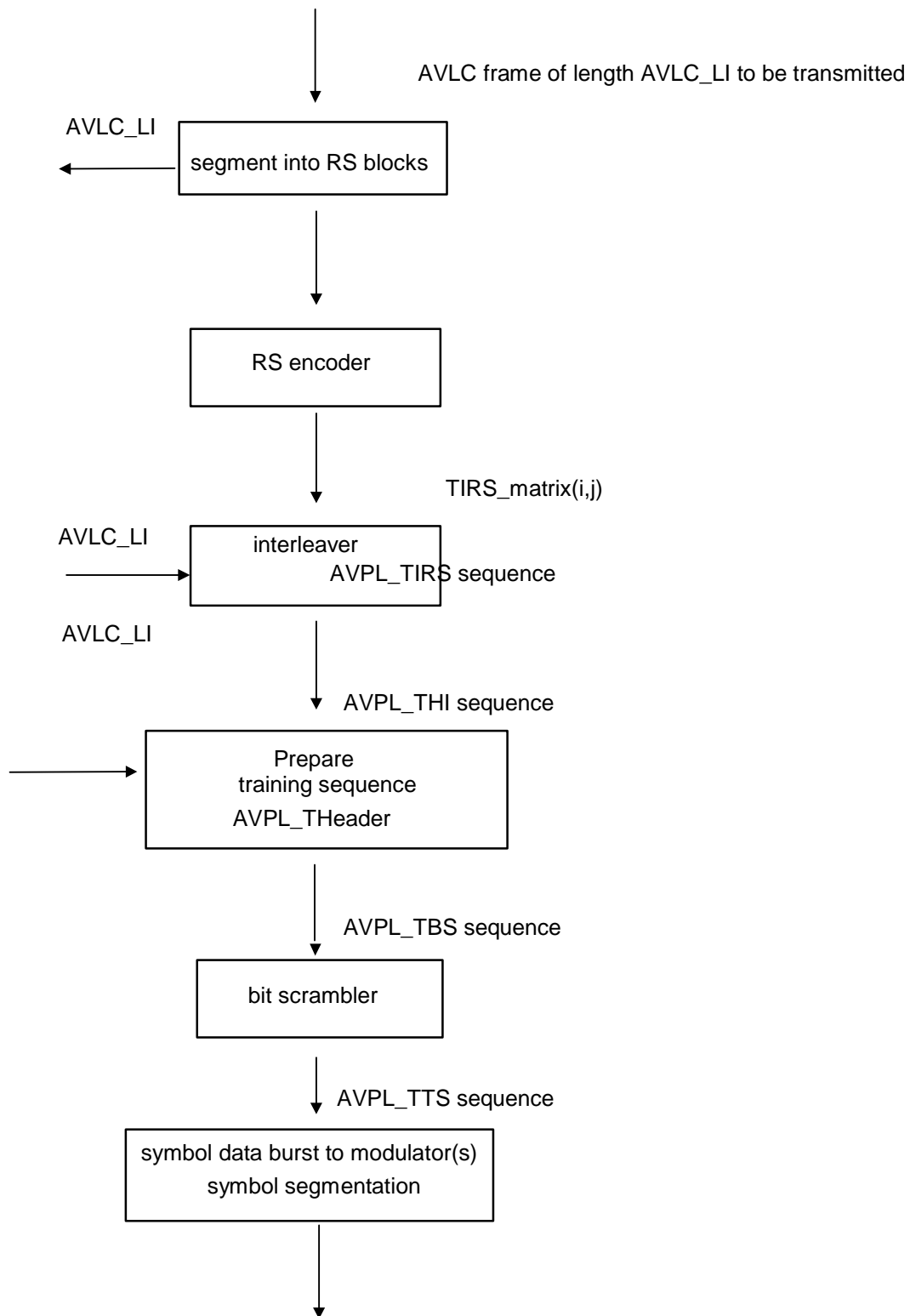

Figure 2: Data burst formatting procedure

5.3 Modulation scheme

Mode 2 shall use D8PSK, using a raised cosine filter with $\alpha = 0.6$ (nominal value). The information to be transmitted shall be differentially encoded with 3 bits per symbol (baud) transmitted as changes in phase rather than absolute phase. The data stream to be transmitted shall be divided into groups of 3 consecutive data bits, with the least significant bit first. Zeros shall be padded to the end of the transmissions if needed for the final channel symbol.

5.4 Training sequence

Data transmission shall begin with a demodulator training sequence consisting of five segments:

- Transmitter ramp up and power stabilization (5 symbols);
- synchronization and ambiguity resolution (16 symbols - the "unique word");
- reserved symbol (1 symbol);
- transmission length (a single 17 bit word); *change bits for symbols*
- header FEC (5 bits).

NOTE: Immediately after these segments there is an AVLC frame.

transmitter power stabilization sequence	synchronization and ambiguity sequence	reserved symbol	transmission length (AVLC_LI)	header FEC
---	---	--------------------	----------------------------------	---------------

Figure 3: AVPL-header training sequence structure

5.4.1 RF power rise time definition

The purpose of the first segment of the training sequence, called the ramp-up, is to provide for transmitter power stabilisation and receiver AGC settling and it shall immediately precede the first symbol of the unique word. The first segment also provides AGC settling time for the intended receiver. The time reference point (T), for the following specification is the centre of the first unique word symbol, a point that occurs $\frac{1}{2}$ a symbol period after the end of the first segment. The start of the first segment is therefore defined at time $T = -5,5$ symbol periods.

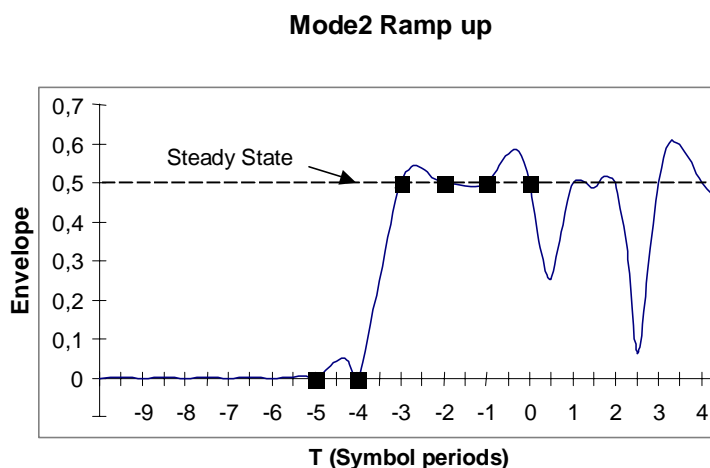

Figure 4-: Transmitter Power Stabilisation

Key: ■ Symbol increment

NOTE: There is a characteristic deep notch in the training sequence (see figure 4) which is located 2.5 symbol periods after the first synchronisation symbol (T_0). Therefore, the RF power level can be checked 5.5 symbol periods (524 μ s) before this "marker" at T_{-3} .

5.5 Physical layer Service Access Point

The Physical Layer SAP protocol is based on the following primitives:

Primitive	Parameters	Value	Comments
AVPL_DATA.req	AVLC_frame	X	From upper layers
	AVLC_LI	Length of AVLC frame	
AVPL_DATA.ind	AVLC_frame	X	To upper layers
	SQP	0 ÷ 15	
AVPL_STATUS.ind	CHANNEL STATUS	BUSY/IDLE	To upper layers

NOTE 1: Physical layer parameters (e.g.: maximum AVL length, operating frequency and test mode) are not handled by this SAP.

NOTE 2: Signal quality analysis shall be performed on the demodulator evaluation process and on the receive evaluation process; this analysis shall be normalized between a scale of 0 and 15, where 0 represents a received signal strength lower than -100 dBm and 15 for a signal strength higher than -70 dBm. SQP value between -100 dBm and -70 dBm is linear.

6 VDL MODE 2 equipment requirements

Unless otherwise stated all specifications shall be met under room conditions, at the nominal data rate, with the transceiver tuned to any 25 kHz channel within the range 118,000 MHz to 136,975 MHz.

6.1 Receiver requirements

The uncorrected BER requirement shall be equal to, or better than 10^{-3} .

The reference signal level applied at the receiver input for all receiver requirements, unless otherwise stated, is -87 dBm.

6.1.1 Sensitivity

A maximum signal level of -98 dBm from a modulated VDL Mode 2 signal source shall produce the uncorrected BER requirement specified in clause 6.1.

6.1.2 First Adjacent Channel Rejection

The minimum adjacent channel rejection ratio (ACR) shall be determined in the presence of the reference signal level (clause 6.1).

The ACR required to achieve the uncorrected BER (clause 6.1) shall be equal to, or greater than, 44 dB. The test shall be performed on each side (± 25 kHz) of the wanted signal.

6.1.3 Rejection of signals in the VHF Aeronautical band

The uncorrected BER requirement (clause 6.1) shall be achieved when the wanted signal, set at the reference signal level (clause 6.1), is combined with an unmodulated interfering signal in the following conditions:

- a) Level of the interfering signal set at -33 dBm at frequencies corresponding to second and third adjacent channels centre.
- b) Level of the interfering signal set at -27 dBm at frequencies corresponding to fourth adjacent channels centre.
- c) Level of the interfering signal set at -27 dBm at a separation of +/- 1 MHz from the nominal receiver frequency.

6.1.4 Rejection of signals **outside** the VHF Aeronautical band

The uncorrected BER requirement (clause 6.1) shall be achieved when one of the specified unwanted signals is applied at the reference signal level (clause 6.1).

Unwanted signal A:

Level: -33 dBm
 Modulation: None
 Frequency range: 108 MHz to 156 MHz (excluding 117,950 MHz to 137,025 MHz).

Unwanted signal B:

Level: -7 dBm
 Modulation: None
 Frequency range: 50 kHz to 1 215 MHz (excluding the range 87,5 MHz to 156 MHz).

NOTE: A maximum interfering level of -33 dBm is permitted at the receiver IF frequencies.

Unwanted signal C:

Level: -5 dBm
 Modulation: None
 Frequency range: 87,5 MHz to 107.9 MHz.

NOTE: The frequency ranges shall be swept at a rate not exceeding $1,5 \times 10^{-3}$ decades/s. Where the frequency range is swept incrementally, the step size shall not exceed 1 % of the previous frequency.

6.1.5 Desired signal dynamic range

The receiver shall continue to achieve the uncorrected BER requirement (clause 6.1) when the desired signal level is increased from the reference signal level to a level of -7 dBm.

6.1.6 Symbol rate capture range

The uncorrected BER requirement (clause 9.12.1) shall be achieved when the reference signal level is subject to a symbol rate offset of ± 50 parts per million.

6.1.7 Frequency capture range

The receiver shall be capable of acquiring and maintaining a lock to any selected channel with the maximum permitted signal frequency offset.

The uncorrected BER requirement (clause 6.1) shall be achieved when the reference signal level is subject to a frequency offset of ± 826 Hz. This value is composed of the maximum transmitter frequency error at 136,975 MHz (± 685 Hz) and the maximum Doppler shift (± 141 Hz).

6.1.8 Co-channel interference

The uncorrected BER requirement (clause 6.1) shall be achieved when a VDL Mode 2 interfering signal, -20 dB below the reference level, is applied in addition to the reference signal level.

6.1.9 Conducted spurious emission

When the receiver input is terminated in a matched impedance, the level of any spurious emission appearing across the load shall not exceed -57 dBm over the frequency range of 50 kHz to 1 215 MHz, with the exception of the range of 108 MHz to 137 MHz, where it shall not exceed -64 dBm.

6.1.10 In-band Intermodulation

The aim of the following requirement is to specify the receiver linearity in order to guarantee the third order interception point (IP3) is at least 0 dBm.

The uncorrected BER requirement (clause 6.1) shall be achieved in the presence of two interfering signals, displaced in frequency, from the desired signal.

Desired signal:

Level: -75 dBm
 Modulation: VDL Mode 2
 Frequency: 118, 127.5MHz to 136,975 MHz

Unwanted signal A:

Level: -32 dBm
 Modulation: none
 Frequency: test frequency +/- 1 MHz

Unwanted signal B:

Level: -32 dBm
 Modulation: VDL Mode 2 (or simulated Mode 2)
 Frequency: test frequency +/- 2 MHz

6.2 Transmitter requirements

Unless otherwise stated, these requirements are applicable to transmitters over the entire frequency range of 118 000 MHz to 136 975 MHz.

Unless otherwise stated, the reference bit sequence is specified as follows:

The maximum "transmit" period is determined by the maximum "burst" length permitted for Mode 2 operation. The maximum burst length is 4,16 s at the nominal symbol rate of 10 500 symbols/s plus the synchronisation sequence.

The minimum "off" period is determined by the minimum transmitter "power down" time plus the minimum "channel idle" detection time plus the minimum value of the inter-access delay timer (TM1). According to ICAO SARPS, the minimum "off" period is 2 ms.

The maximum duty cycle is therefore 4,16 s in "transmit" mode followed by 3,1 ms "off". The reference bit sequence shall not exceed 15 cycles.

6.2.1 Protection of the transmitter

The protection of the transmitter represents the ability of the transmitter to be protected against malfunction due to faults in the antenna system. Worst case mis matches are represented by a short and open circuit test. The transmitter shall operate normally after the completion of the test.

6.2.2 Manufacturer's declared output power

The carrier power is the mean RF power delivered to the coaxial matched impedance termination during transmission. The measured power shall be ± 1 dB of the manufacturer's stated maximum output power.

The requirements of the present document shall also be met for all power output levels at which the transmitter is intended to operate into 50 ohms. For practical reasons measurements shall be performed only at the lowest and the highest power output level at which the transmitter is intended to operate.

6.2.3 RF power rise time

The transmitter output power shall achieve at least 90 % of the manufacturers' declared output power level in a time less than 190 μ s (two symbols).

The transmitted output power shall be less than -40 dBc. prior to the start of the first segment (T -5,5 symbol periods).

The transmitter power stabilization segment shall consist of 5 symbols each representing 000 (2 symbols for the RF power rise time and 3 symbols for the receiver AGC stabilization).

NOTE: In order to minimise the transient effect of power rising on an adjacent channel, attention must be paid to the profile of the R.F. signal during the ramp-up period.

6.2.4 RF power release time

The transmitter output power shall decay at least 20 dB below the manufacturers' declared output power level (clause 5.12.2.20) within 300 μ s after transmitting the final information symbol.

NOTE: In order to minimise the transient effect of power decreasing on an adjacent channel, attention must be paid to the profile of the R.F. signal during the ramp-down period.

6.2.5 Modulation rate

The Mode 2 symbol rate shall be 10 500 symbols/second \pm 50 ppm, resulting in a nominal bit rate of 31 500 bits/s.

6.2.6 Symbol constellation error

The rms Error Vector Magnitude (EVM), when measured over the first 30 symbols of the reference bit sequence, shall be less than 6 %.

6.2.7 Conducted Spurious emissions

When the transmitter is "active" or "idle" (or the transceiver is in receive mode) and terminated in a matched impedance load, the power of any spurious emission at the output of the transmitter shall not exceed the values given in table 1.

Table 1

Environmental phenomena	Frequency range	Units	Test limits, Tx Standby	Test limits Tx active mode	Reference bandwidth
Spurious conducted RF Emissions	9 kHz to 150 kHz	dBm	-57 (2 nW)	-36 dBm	B = 1 kHz
Spurious conducted RF Emissions	> 150 KHz to 1 GHz	dBm	-57 (2 nW)	-36 dBm for harmonics, -46 dBm for non-harmonic spurious	B = 10 kHz (see note 1 and note 2)
Spurious conducted RF Emissions	> 1 GHz to 4 GHz	dBm	-47 (20 nW)	-30 dBm for harmonics -40 dBm for non-harmonic spurious	B = 10 kHz
NOTE 1: For transmitters with an RF output above 50 W a limit of -80 dBc will be applied for harmonically related spurious.					
NOTE 2: An exclusion band of ± 1 MHz about the carrier shall be used in active transmit mode.					

6.2.8 Adjacent channel power

First adjacent channel power:

The RF power measured over a 16 kHz channel bandwidth centred on the first adjacent channel shall not exceed -18 dBm.

Second adjacent channel power:

The RF power measured over a 25 kHz channel bandwidth centred on the second adjacent channel shall not exceed -28 dBm.

Fourth adjacent channel power:

The RF power measured over a 25 kHz channel bandwidth centred on the fourth adjacent channel shall not exceed -38 dBm.

6.2.9 Wide-band noise

The RF power measured in a 25 kHz channel bandwidth shall reduce at a minimum rate of 5 dB per octave from the fourth adjacent channel to a maximum value of -53 dBm.

6.2.10 Frequency Tolerance

The frequency of the RF carrier shall be within ± 2 ppm of the selected frequency.

6.2.11 Cabinet radiation

Reference: ERM Radio equipment intended for the transmission of data (and speech) and having an antenna connector, EN 300 113-1 [17].

6.3 Transceiver timing requirements

6.3.1 Receiver to transmitter turn-around time

A ground base station shall begin the transmission of the unique word portion of the training sequence within 1.25 ms after terminating the receive function.

6.3.2 Transmitter to receiver turn-around time

A ground base station shall be capable of receiving and demodulating an incoming signal within 1.5 ms after transmitting the final information symbol.

7 General requirements

7.1 General

The equipment shall be able to operate on all channels in the list of assignable frequencies defined in Group F (paragraph 4.1.8.1.2) of [1] the ICAO Annex 10 Volume V clause 4.1.2.4.

It shall not be possible to transmit while any frequency synthesizer used within the transmitter is out of lock.

It shall not be possible to transmit during channel switching operations.

7.2 Controls and indicators

The equipment shall have the following controls and indicators as a minimum:

- a visual indication that the device is switched on;
- a visual indication that the carrier is being produced.

7.3 Class of emission and modulation characteristics

The equipment shall use D8PSK modulation with the emission designator 14K0G1DE. The equipment shall be designed to operate satisfactorily with a channel separation of 25 kHz.

7.4 Warm up

After being switched on the equipment shall be operational within five seconds and shall be able to meet the performance requirements of the present document within one minute under normal conditions.

8 Test conditions, power sources and ambient temperatures

8.1 Test power source

During testing, the equipment shall be supplied from a test power source capable of producing normal and extreme test voltages as specified in clause 8.4.2.3.

The internal impedance of the test power source shall be low enough for its effect on the test results to be negligible. For the purpose of testing the power source voltage shall be measured at the input terminals of the equipment.

During testing, the power source voltages shall be maintained within a tolerance of ± 3 % relative to the voltage level at the beginning of each test.

8.2 Test channels

Tests shall be carried out on at least three channels:

- 118,000 MHz
- 127,500 MHz
- 136,975 MHz

8.3 General conditions of measurement

8.3.1 Receiver test signal arrangement

Test signal sources shall be connected to the receiver input in such a way that the impedance presented to the receiver input is 50 ohm, irrespective of whether one or more test signals are applied to the receiver simultaneously.

8.3.2 Performance check

Whilst the equipment is being subjected to the normal or extreme test conditions, establish compliance with the requirements of the following paragraphs:

- 6.1.1 Sensitivity (Rx)
- 6.2.2 Manufacturer's declared output power (Tx)
- 6.2.10 Frequency Tolerance (Tx)

8.4 Normal and extreme test conditions

Measurements shall be made under normal test conditions and also, where stated, under extreme test conditions.

8.4.1 Normal test conditions

8.4.1.1 Normal temperature and humidity

The normal temperature and humidity conditions for tests shall be a combination of temperature and humidity within the following ranges:

- temperature: +15°C to +35°C;
- relative humidity: 20 % to 75 %.

When it is impracticable to carry out the tests under these conditions, a note to this effect, stating the ambient temperature and relative humidity during the tests, shall be added to the test report.

8.4.1.2 Normal power sources

8.4.1.2.1 Mains voltage and frequency

The normal test voltage for equipment to be connected to the mains shall be the nominal mains voltage.

For the purpose of this standard, the nominal voltage shall be the declared voltage or any of the declared voltages for which the equipment was designed.

The frequency of the test power source shall correspond to the appropriate AC mains.

8.4.1.2.2 Other power sources

For operation from other power sources, the normal test voltage shall be that declared by the equipment manufacturer.

8.4.2 Extreme test conditions

8.4.2.1 Extreme temperatures

For tests at extreme temperatures, measurements shall be made at a lower temperature of -10°C and an upper temperature of $+55^{\circ}\text{C}$. This test shall be performed at the nominal supply voltage as defined in clause 8.4.1.2.1.

8.4.2.2 Procedure for tests at extreme temperatures

8.4.2.2.1 General

The equipment shall be switched off during the temperature stabilizing periods.

For tests at the upper temperature on equipment designed for continuous operation, the equipment shall be placed in the test chamber and left until thermal equilibrium is reached. The equipment shall then be switched on for 30 minutes before measurements are made. Transmitters shall be operated in the highest rated power transmit condition in that 30 minutes period before measurements are made.

For tests at the lower temperature, the equipment shall be left in the test chamber until thermal equilibrium is reached. The equipment shall then be switched on for 1 minute in the standby or receive condition before measurements are made.

8.4.2.2.2 High temperature

- Place the equipment in a chamber and heat to 55°C ($\pm 3^{\circ}\text{C}$) and allow to stabilise for 1 hour.
- Switch on the equipment (transmitters shall be keyed).
- After 30 minutes carry out a performance check as detailed in clause 8.4.2.4.
- Switch off the equipment and allow the chamber to cool to room temperature over a 1 hour period.
- Allow time for the equipment to stabilise to normal room temperature and humidity before carrying out the next test.

8.4.2.2.3 Low temperature

- Place the equipment in a chamber and cool to -10°C ($\pm 3^{\circ}\text{C}$) for 2 hours.
- Switch on the equipment and maintain the chamber operating temperature at -10°C ($\pm 3^{\circ}\text{C}$)
- After 1 minute carry out a performance check as detailed in clause 8.4.2.4
- Switch off the equipment and allow the chamber to rise to room temperature over a 1 hour period.
- Allow time for the equipment to stabilise to normal room temperature and for moisture to disperse before carrying out the next test.

8.4.2.3 Extreme values of test power sources

Mains voltage

- The extreme test voltages shall be $\pm 10\%$ of the value declared in clause 8.4.1.2.1.
- The frequency of the test voltage shall be the nominal frequency of the supply as declared in clause 8.4.1.2.1.
- This test shall be performed at the normal temperature and humidity as defined in clause 8.4.1.1.

8.4.2.4 Other power sources

For equipment using other power sources, or capable of being operated from a variety of power sources, the extreme test voltages shall be those agreed between the equipment manufacturer and the testing laboratory and shall be recorded in the test report.

8.4.2.5 Performance check

Whilst the equipment is being subjected to the extreme test conditions, establish compliance with the requirements of clause 8.3.2.

9 Detailed Test Procedures for the physical layer

The following test procedures provide a satisfactory means of establishing compliance with the requirements of clause 5.12 of this document. However, alternative test procedures, which provide equivalent information, may be used.

Signal quality analysis shall be performed on the demodulator evaluation process and on the receive evaluation process; this analysis shall be normalized between a scale of 0 and 15, where 0 represents a received signal strength lower than -100 dBm and 15 for a signal strength higher than -70 dBm. SQP value between -100 dBm and -70 dBm is linear.

9.1 Receiver

9.1.1 BER test

A BER test shall use a VHF signal generator representing the desired source signal and external BER test equipment (e.g. a computer & test software or AWG interfaced to the VHF signal generator in vector modulation mode), which receives each burst payload from the receiver.

Uncorrected BER mode

A method for placing the receiver into the uncorrected BER mode shall be provided by manufacturers. The uncorrected BER mode is distinct from the operational mode.

The uncorrected BER mode is used to measure the uncorrected BER requirement.

- 1) The receiver shall forward each burst payload to the external BER test equipment without error detection or correction procedures.
- 2) The test payload shall be forwarded to the external BER test equipment only if the burst was successfully detected via the standard 16 symbols synchronization sequence.

VHF signal generators

Receiver test procedures require the use of a high performance VHF signal generator in order to permit high precision measurement. This VHF signal generator shall be capable of the specified modulation format and transmission waveform.

- 1) The VHF signal generator shall support transmission of VDL test bursts consisting of the ramp up period plus the standard 16 symbols synchronization sequence followed by a variable length test message, up to the maximum length of 43 771 symbols .
- 2) An external interface to the VHF signal generator shall be provided in order that the test payload can be provided via the external BER test equipment

External BER test equipment

- 1) The test payload provided by the external BER test equipment shall be mapped directly into the burst payload in Mode-2 format. The formatting shall include cyclic redundancy check (CRC), interleaving, scrambling and header.

NOTE: Forward Error Correction (FEC) may be encoded or left null, as this information will not be used when the receiver is configured to output "uncorrected" BER messages.

- 2) Unless otherwise stated, tests shall be conducted with maximum length Mode-2 messages
- 3) The external BER test equipment generating the test payload for transmission by the VHF signal generator, and receiving/processing the received test payload must be synchronized either explicitly (via a direct connection) or implicitly (by knowledge of the test payload).
- 4) Calculation of cumulative BER statistics shall begin once synchronization of the external BER test equipment between the transmitting and receiving burst payload has been accomplished. The receiving external BER test equipment shall detect the loss of an entire burst implicitly by lack of a burst payload message in the given burst period. Each test should include a running count of synchronization failures in addition to the cumulative BER.

Interfering (or undesired) source

Tests for CCI and ACR with the VDL waveform as the interfering signal shall be performed with the interfering signal applied in a continuous (non-pulsed) manner. The waveform shall simulate a VDL Mode-2 signal. Tests have shown that a suitable interfering source is a VHF signal generator configured to produce a narrow-band FM signal modulated with a 400 Hz tone at a peak frequency deviation of 5.25 kHz.

Figure 5 shows the basic test setup for receiver BER tests.

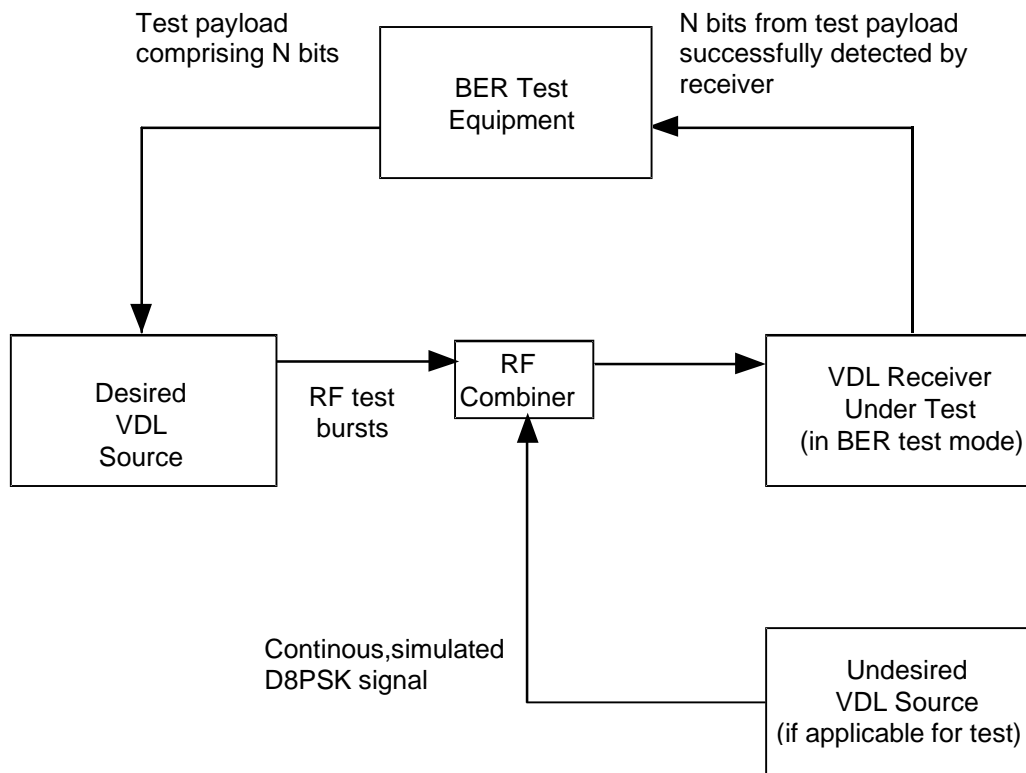

Figure 5: Receiver BER measurement

9.1.2 Sensitivity (clause 6.1.1)

The following equipment is required:

VHF Signal Generator

- External BER test equipment
- The measurement procedure consists of the following steps:

Step 1: Connect the equipment as shown in figure 5 but notice that the RF combiner is not required for this test. Set the receiver under test into the uncorrected BER mode.

- Step 2: Set the desired VDL source, (a VHF signal generator) to generate an input signal to the receiver at one of the test frequencies (clause 8.2).
- Step 3: Modulate the desired signal with the test payload (maximum burst length of symbols) provided by the external BER test equipment. Adjust the level of the signal generator to the maximum signal level (clause 6.1.1) at the receiver input terminals.
- Step 4: Repeat Steps 2 & 3 at the two remaining test frequencies (clause 8.2).
- Step 5: Using the external BER test equipment, determine the uncorrected BER of the demodulated data at the receiver output. Check the sensitivity requirement (clause 6.1.1) is achieved at all three test frequencies.

9.1.3 First Adjacent Channel Rejection (clause 6.1.2)

The following equipment is required:

- 2 VHF Signal Generators
- External BER test equipment
- RF combiner

The measurement procedure consists in the following steps:

- Step 1: Connect the equipment as shown in figure 5 and set the receiver to the uncorrected BER mode.
- Step 2: Adjust the Desired VDL Source (generator A), to produce an input signal to the receiver at one of the test frequencies (clause 8.2).
- Step 3: Modulate generator A with with the test payload (maximum burst length of symbols) provided by the external BER test equipment. Adjust signal generator A to produce the reference signal level (clause 6.1.1) at the receiver input terminals.
- Step 4: Use the second VHF signal generator (named B), to generate an adjacent channel interfering input signal to the receiver.
- Step 5: Tune generator B to the first upper adjacent channel frequency. Set generator B to produce a narrow-band F.M signal (to simulate a second VDL Mode-2 source). Apply the desired input signal and the adjacent interfering signal to the receiver input via the RF combiner.
- Step 6: Adjust the level of signal generator B until the uncorrected BER is reduced to the minimum requirement (clause 6.1.1). Record the interfering signal level at the receiver input terminals
- Step 7: Repeat Step 5 and 6 for the lower adjacent channel.
- Step 8: Determine the ratio between the Desired and Interfering signal levels for both upper and lower adjacent channels. Record the highest of these two values.
- Step 9: Repeat Steps 4 to 8 at the two remaining test frequencies (clause 8.2).
- Step 10: Check that the ACR requirement (defined in clause 6.1.2) is achieved in all cases.

NOTE: The noise sidebands of the interfering signal must not interfere with the desired signal in the receiver passband. The isolation offered by the RF combiner must be sufficient to prevent intermodulation between the VHF generators.

9.1.4 Rejection of signals **within** the VHF Aeronautical band (clause 6.1.3)

The following equipment is required:

- 2 VHF Signal Generators
- External BER test equipment
- RF combiner

NOTE: The noise sidebands of the interfering signal must not interfere with the desired signal in the receiver passband. The isolation offered by the RF combiner must be sufficient to prevent intermodulation between the VHF generators.

The measurement procedure consists in the following steps:

- Step 1: Connect the equipment as shown in figure 5 - and set the receiver to the uncorrected BER mode
- Step 2: Adjust the Desired VDL Source , generator A, to produce an input signal to the receiver at one of the test frequencies (clause 8.2).
- Step 3: Modulate generator A with the test payload (maximum burst length of symbols) using the external BER test equipment. Adjust signal generator A to provide the reference signal level (clause 6.1.1) at the receiver input terminals.
- Step 4: Set the second signal generator (named B), to produce an unmodulated (c.w) interfering signal to the receiver input.
- Step 5: Tune generator B to the second adjacent channel and adjust the signal generator to the level defined in clause 6.1.3 a).
- Step 6: Apply the wanted input signal and the unmodulated interfering signal to the receiver input via the RF combiner and determine the uncorrected BER of the demodulated data with the external BER test equipment.
- Step 7: Repeat Step 5 and 6 for the other channels stated in clause 6.1.3 a).
- Step 8: Tune generator B to the upper fourth adjacent channel and adjust the signal generator to the level stated in 6.1.3 b).
- Step 9: Apply the wanted input signal and the unmodulated interfering signal to the receiver input via the RF combiner and determine the uncorrected BER of the demodulated data with the external BER test equipment.
- Step 10: repeat steps 8 and 9 for the lower fourth adjacent channel.
- Step 11: Set the second signal generator (named B), to produce an unmodulated (c.w) interfering signal to the receiver input.
- Step 12: Repeat steps 5 to 11 at the other test frequencies (clause 8.2)

9.1.5 Rejection of signals **outside** the VHF Aeronautical band (clause 6.1.4)

The following equipment is required:

- 2 VHF Signal Generators
- External BER test equipment
- RF combiner

The measurement procedure consists in the following steps:

- Step 1: Connect the equipment as shown in figure 5 - and set the receiver to the uncorrected BER mode.
- Step 2: Use the Desired VDL Source (generator A), to produce an input signal to the receiver at one of the test frequencies (clause 8.2).
- Step 3: Modulate generator A with the test payload (maximum burst length of symbols) using the external BER test equipment. Adjust signal generator A to provide the reference signal level (clause 6.1.1) at the receiver input terminals.
- Step 4: Use the second signal generator (named B), to generate one of the specified interfering signals at the receiver input.
- Step 5: Tune generator B to any frequency defined in clause 6.1.4. Adjust the level of generator B to provide the interfering signal level also defined in clause 6.1.4, at the receiver input terminals.
- Step 6: Apply the desired input signal and the interfering signal to the receiver input via the RF combiner and determine the uncorrected BER with the external BER test equipment.
- Step 7: Repeat Step 5 and 6 for all other frequencies.
- Step 8: Check that the uncorrected BER requirement (clause 6.1.1) is achieved in all cases.

NOTE 1: The noise sidebands of the interfering signal must not interfere with the desired signal in the receiver passband. The isolation offered by the RF combiner must be sufficient to prevent intermodulation between the VHF generators.

NOTE 2: Any interfering signal found to reduce the uncorrected BER below the minimum requirement should be investigated using a spectrum analyser connected to the combiner output. This should determine whether the RF combiner/test setup is producing an on-channel signal into the receiver under test.

NOTE 3: Alternative procedures or theoretical calculation of susceptible frequencies may be used to reduce the number of discrete frequencies which need to be tested.

9.1.6 Desired Signal dynamic range (clause 6.1.5)

The following equipment is required:

- VHF Signal Generator
- External BER test equipment

The measurement procedure consists in the following steps:

- Step 1: Connect the equipment as shown in figure 5 - but notice that the RF combiner is not needed for this test. Set the receiver to the uncorrected BER mode.
- Step 2: Adjust the Desired VDL Source (generator A) to generate an input signal, to the receiver, at one of the test frequencies (clause 8.2).
- Step 3: Modulate generator A with the test payload (maximum burst length of symbols) using the external BER test equipment. Adjust generator A to provide the maximum reference signal level (clause 6.1.5) at the receiver input terminals.
- Step 4: Apply the modulated signal to the receiver and determine the uncorrected BER of the demodulated data at the receiver output with the external BER test equipment.
- Step 5: Check that the uncorrected BER requirement (clause 6.1.1) is achieved in all cases.

9.1.7 Symbol rate capture range (clause 6.1.6)

The following equipment is required:

- VHF Signal Generator
- External BER test equipment

The measurement procedure consists in the following steps:

- Step 1: Connect the equipment as shown in figure 5 - but notice that the RF combiner is not needed for this test. Set the receiver to the uncorrected BER mode.
- Step 2: Tune the Desired VDL Source (generator A) to generate an input signal to the receiver at one of the test frequencies (clause 8.2). Adjust generator A to provide the reference signal level (clause 6.1.1) at the receiver input terminals.
- Step 3: Tune the VHF signal generator to the receiver channel frequency and modulate it with the test payload (maximum burst length of symbols) provided by the external BER test equipment.
- Step 4: Adjust the transmitted data clock offset of the external BER test equipment to the maximum offset specified in clause 6.1.6.
- Step 5: Apply the modulated signal to the receiver and determine the uncorrected BER of the demodulated data at the receiver output with the external BER test equipment.
- Step 6: Repeat Steps 4 & 5 after adjusting the transmitted data clock offset to the minimum offset specified in clause 6.1.6.
- Step 7: Check that the uncorrected BER requirement (clause 6.1.1) is achieved in all cases

9.1.8 Frequency capture range (clause 6.1.7)

The following equipment is required:

- VHF Signal Generator
- External BER test equipment

The measurement procedure consists in the following steps:

- Step 1: Connect the equipment as shown in figure 5 - but notice that the RF combiner is not needed for this test. Set the receiver to the uncorrected BER mode.
- Step 2: Set the Desired VDL Source (generator A) and the external BER test equipment to generate a receiver input signal.
- Step 3: Tune generator A to one of the test frequencies (clause 8.2) plus the frequency offset (defined in clause 6.1.7) and modulate it with the test payload (maximum burst length of symbols) provided by the external BER test equipment. Adjust generator A to provide the reference signal level (clause 6.1.1) at the receiver input terminals.
- Step 4: Apply the modulated signal to the receiver and determine the uncorrected BER of the demodulated data at the receiver output with the external BER test equipment.
- Step 5: Repeat Steps 3 to 5 for the negative frequency offset (clause 6.1.7).
- Step 6: Check that the uncorrected BER requirement (clause 6.1.1) is achieved in all cases.

9.1.10 Co-channel interference (clause 6.1.8)

The following equipment is required:

- 2 VHF Signal Generators
- External BER test equipment
- RF combiner

The measurement procedure consists in the following steps:

- Step 1: Connect the equipment as shown in figure 5, and set the receiver to the uncorrected BER mode.
- Step 2: Use the Desired VDL Source (named A), to generate a desired input signal to the receiver.
- Step 3: Tune the generator A to one of the test frequencies (clause 8.2) and modulate the carrier with the test payload (maximum burst length of symbols) provided by the external BER test equipment. Adjust generator A to provide the reference signal level (clause 6.1.1) at the receiver input terminals.
- Step 4: Use the second signal generator (named B), to generate a co-channel interfering input signal to the receiver.
- Step 5: Tune the signal generator B to the receiver channel frequency and configure it to produce a narrow band FM signal with a maximum deviation of $\pm 5,25$ kHz. Modulate generator B with a 400 Hz sinewave. Adjust generator B to produce an interfering signal level 20 dB below the reference signal level (clause 6.1.1) at the receiver input terminals.
- Step 6: Apply the desired signal and the co-channel interfering FM modulated signal to the receiver input via the RF combiner and measure the uncorrected BER of the demodulated data at the receiver output with the external BER test equipment.
- Step 7: Repeat Steps 2 to 6 at the two remaining test frequencies (clause 8.2).
- Step 8: Check that the uncorrected BER requirement (clause 6.1.1) is achieved in all cases.

9.1.11 Conducted spurious emission (clause 6.1.9)

The following equipment is required:

- Resistive load equal to the nominal input impedance of the receiver
- Calibrated spectrum analyser to cover the frequency range defined in clause 3.2.1.10.

The measurement procedure consists in the following steps:

- Step 1: Connect the r.f output of the equipment under test directly into the RF input of the spectrum analyser. Exercise caution, do not allow the transmitter to radiate.
- Step 2: Tune the transceiver to one of the test channels (clause 8.2).
- Step 3: Using the calibrated spectrum analyser, measure the power level of any spurious emissions across the matching resistive load at the input of the receiver over the frequency range defined in clause 6.1.9.
- Step 4: Record the frequency and power level of all signals which exceed the limit specified in clause 6.1.9
- Step 5: Repeat Steps 2 to 4 at the two remaining test channels (clause 8.2)
- Step 6: Check that the requirements of clause 6.1.9. are achieved

9.1.12 In-band Intermodulation (clause 6.1.10)

The following equipment is required:

- 3 VHF Signal Generator
- External BER test equipment
- RF combiner

The measurement procedure consists in the following steps:

- Step 1: Connect the equipment as shown in figure 6 .
- Step 2: Use a signal generator (named A), to generate the desired input signal to the receiver.
- Step 3: Tune generator A to one of the test frequencies (clause 8.2.) and modulate the carrier with the test payload (maximum burst length of symbols) provided by the external BER test equipment. Adjust generator A to provide a level of -75 dBm. at the receiver input terminals.
- Step 4: Tune interfering signal generator B to a frequency 1 MHz above the selected test frequency. Set signal generator B to produce an unmodulated carrier, input to the receiver input terminals at a level of -32 dBm.
- Step 5: Tune interfering signal generator C to a frequency 2 MHz above the selected test frequency. Set signal generator C to produce a simulated Mode 2 signal , input to the receiver input terminals at a level of -32 dBm.
- Step 6: Apply the desired signal and the two interfering signals to the receiver input via the RF combiner and determine the uncorrected BER of the demodulated data at the receiver output with the external BER test equipment.
- Step 7: Repeat Steps 3 to 6 for the remaining frequency combinations by retuning generators B and C.
- Step 8: Check that the uncorrected BER requirement (clause 6.1.1) is achieved in every case.

NOTE: In the absence of the desired signal (i.e Generator A switched "off"), the intermodulation products produced by any interaction between the interfering signal generators B & C, must be less than -105 dBm at the receiver input. Additional band-pass filters, inserted between each generator and the R.F combiner, may be necessary to reduce the intermodulation product.

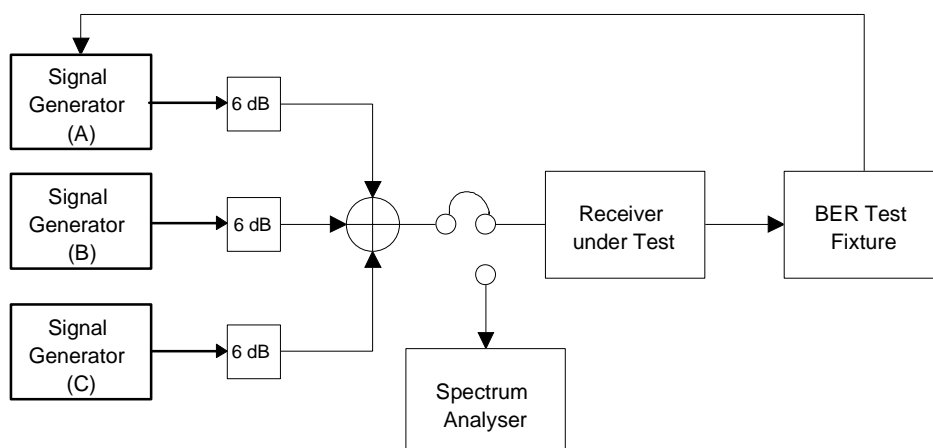

Figure 6: Intermodulation measurement

9.2 Transmitter

9.2.2 Manufacturer's declared output power (clause 6.2.2)

The following equipment is required:

- Transmission generator, PC with suitable software
- Attenuator 30 dB
- Power meter, with pulse power measurement facility or vector signal analyser.

The measurement procedure consists in the following steps:

- Step 1: Connect the equipment as shown in figure 7.
- Step 2: Tune the transmitter to one of the test frequencies (clause 8.2).
- Step 3: Key the transmitter under test "on" and modulate the carrier with continuous maximum length Mode 2 messages from the transmission generator.
- Step 4: Set the power meter (or VSA) to capture the Mode 2 transmitted signal and determine the average transmitter output power during the message period.
- Step 5: Repeat Steps 2 to 4 at the two remaining test channels.
- Step 6: Check that the manufacturers declared output power is not more than the requirement in clause 6.2.2, and remains so at all three test channels.

NOTE: Output power delivered into a 50 ohms load shall be measured during signal transmission (steady state power level) and shall not be averaged over the time intervals between signal transmissions.

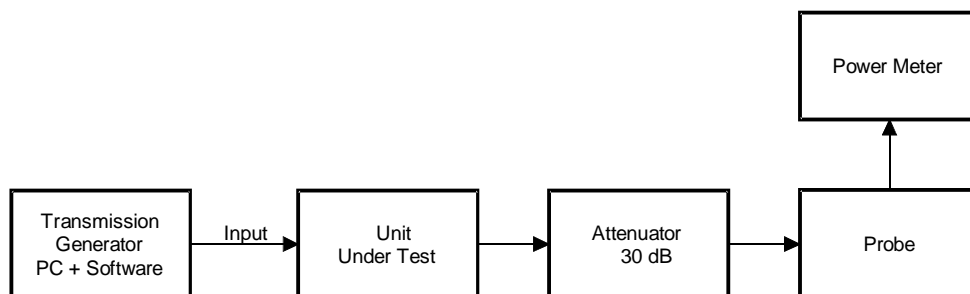

Figure 7: Output power measurement

9.2.3 RF power rise time (clause 6.2.3)

The following equipment is required:

- Transmission Generator, PC with suitable software
- Attenuator 30 dB
- VSA

The measurement procedure consists in the following steps:

- Step 1: Connect the equipment as shown in figure 8.
- Step 2: Configure the vector analyser to display both constellation diagram and power versus time charts shown in figure 9.
- Step 3: Use the transmission generator to produce a minimum length Mode 2 message and capture the start of this message.

- Step 4: Using both constellation and power versus time display identify the first symbol of the synchronisation sequence.
- Step 5: Check RF power level 3 symbol periods before the first synchronisation symbol (defined in clause 5.4.1) occurs .
- Step 6: Check that the RF power rise time (defined in clause 6.2.3) is achieved.

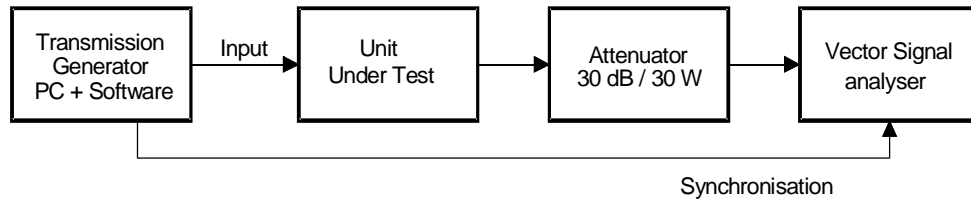

**Figure: 8 RF POWER RISE and RELEASE TIME MEASUREMENT
also suitable for SYMBOL CONSTELLATION ERROR**

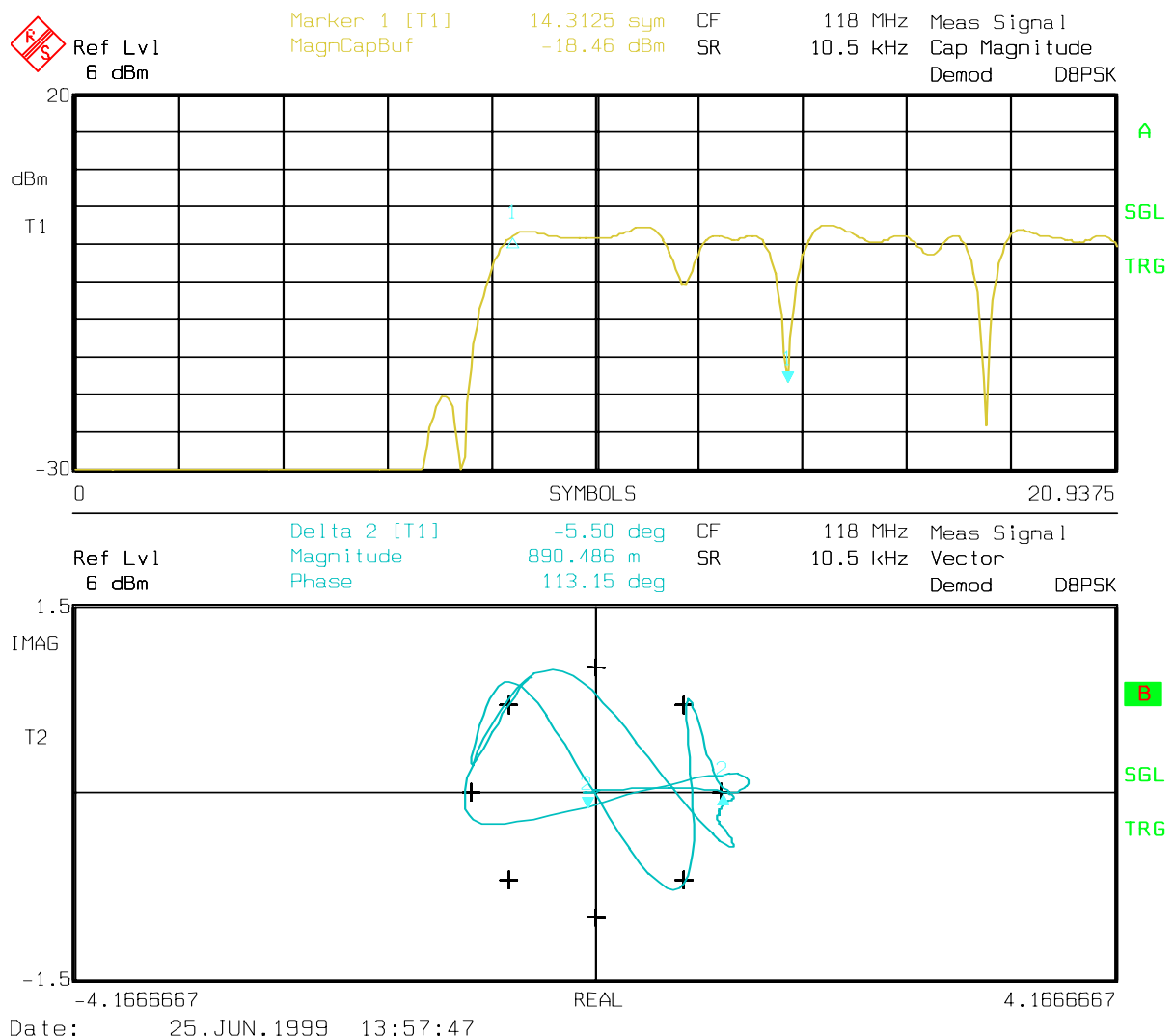

Figure: 9 VSA displays illustrating R.F. rise-time

NOTE: There is a characteristic notch in the synchronisation sequence which is located 2.5 symbol periods after the first synchronisation symbol. Therefore, it is easy to check the RF power level 5.5 symbol periods (524 μ s) before this "marker". This could constitute an alternative method using a standard spectrum analyser or fast storage oscilloscope. (see figure 9).

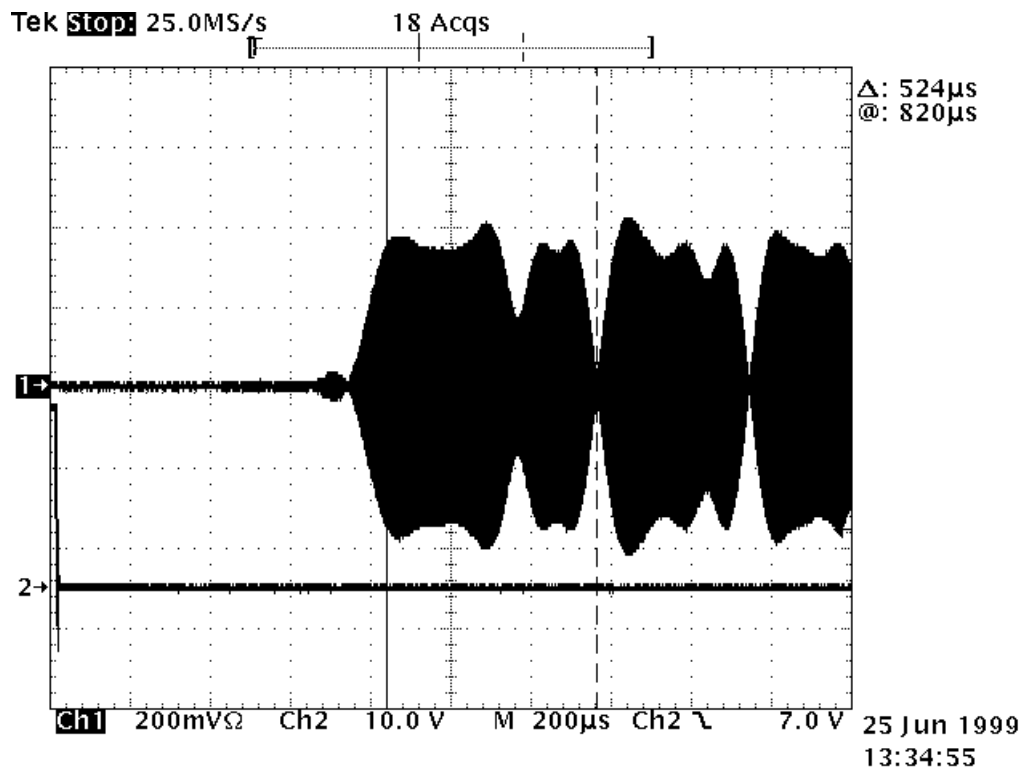

Figure: 9a VSA displays illustrating R.F. rise-time

9.2.4 RF power release time (clause 6.2.4)

The following equipment is required:

- Transmission Generator, PC with suitable software
- Attenuator 30 dB
- VSA

The measurement procedure consists in the following steps:

- Step 1: Connect the equipment as shown in figure 8.
- Step 2: Configure the vector signal analyser in digital demodulation mode, to display log magnitude of I & Q vectors, with normalisation disabled. Set the Y axis to read "dBm" The symbol times are displayed on the resultant profile of power versus time. Use of the trigger hold off function will aid signal acquisition.
- Step 3: Using the transmission generator to produce a minimum length Mode 2 message. Capture the end of this message on the vector signal analyser.
- Step 4: Use the power versus time display to determine the corresponding profile for each symbol of the "power down" ramp.
- Step 5: Check that the RF power release time (defined in clause 6.2.4) is achieved.

9.2.5 Symbol Constellation Error (clause 6.2.6)

The following equipment is required:

- Transmission generator, PC with suitable software
- Attenuator 30 dB
- Vector Signal analyser

The measurement procedure consists in the following steps:

- Step 1: Connect the equipment as shown in figure 8.
- Step 2: Tune the transmitter to one of the test frequencies
- Step 3: Tune the vector signal analyser to the correct channel frequency and modulation scheme, select a suitable level range.
- Step 4: Key the transmitter under test "on" and modulate it with continuous maximum length Mode 2 messages produced by the transmission generator.
- Step 5: Record the rms EVM error at symbol centres.
- Step 6: Check that the results are within the limits specified in clause 6.2.6.
- Step 7: Repeat Steps 2 to 6 at the two remaining test frequencies

9.2.6 Spurious emissions (clause 6.2.7)

The following equipment is required:

- Transmission Generator, PC with suitable software
- Attenuator 30 dB
- Notch filters or bandpass filters, to suppress the on-channel signal by at least 60 dB.
- Spectrum analyser with power band marker function.

The measurement procedure consists in the following steps:

- Step 1: Connect the equipment as shown in figure 10.
- Step 2: Tune the transmitter to one of the test frequencies
- Step 3: Use the filters to reject the on-channel signal in order to increase the dynamic range of the measurement without overloading the spectrum analyser.
- Step 4: Set the transmission generator to produce continuous maximum length Mode 2 messages and key the transmitter under test "on".
- Step 5: Adjust the spectrum analyser reference level to provide the maximum dynamic range for display and set the input attenuator to minimum required to ensure that no signal at the analyser input exceeds the maximum allowable level.
- Step 6: Measure the power level at each visible spurious signal using power band markers appropriate to the bandwidths specified in (clause 6.2.7).
- Step 7: Measure the frequency response of the filter and take this into account when presenting spurious measurement results. If a bandpass filter is used, it will need to be tuned to several measurement frequencies, covering the overall measured frequency range.
- Step 9: Check that the results do not exceed the limits specified in clause 6.2.7.

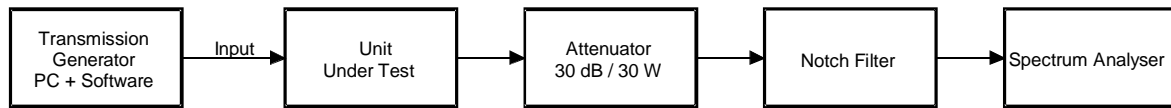

Figure 10: Spurious emissions measurement

9.2.7 Adjacent channel power (clause 6.2.8)

9.2.7.1 Method of measurement for the first adjacent channel

The following equipment is required:

- Transmission Generator, PC with suitable software
- Attenuator 30 dB
- Spectrum analyser with power band marker function

The measurement procedure consists in the following steps:

- Step 1: Connect the equipment as shown in figure 11.
- Step 2: Tune the transmitter to one of the test frequencies
- Step 3: Key the transmitter under test "on" and modulate it with the transmission generator to produce continuous maximum length Mode 2 messages.
- Step 4: Adjust the attenuator in the analyser to the minimum value which does not overload the input stage of the unit.
- Step 5: Using 100 kHz span display the Mode 2 signal envelope. Use the analyser IF signal power as the trigger source for the display and set averaging to 10.
- Step 6: Using the power band marker function of the analyser measure the power in a 16 kHz bandwidth, of the first upper adjacent channel.
- Step 7: Repeat Steps 3 to 6 for the first lower adjacent channel.
- Step 8: Record the highest of the two measured values. Check that the first adjacent channel power is lower than the first adjacent channel power requirement (defined in clause 6.2.8).
- Step 9: Repeat Steps 2 to 8 at the two remaining test frequencies

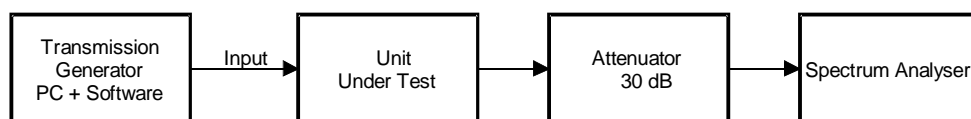

Figure: 11: First adjacent channel power measurement

9.2.7.2 Method of measurement for the second adjacent channel

The following equipment is required:

- Transmission Generator, PC with suitable software
- Attenuator 30 dB
- VHF crystal filter with a 3 dB bandwidth of 25 kHz and, with attenuation in excess of 50 dB at ± 50 kHz.
- Spectrum analyser with power band marker function.

The measurement procedure consists in the following steps:

- Step 1: Connect the equipment as shown in figure 12.
- Step 2: Tune the transmitter to one of the test frequencies
- Step 3: Offset the tuned frequency of the transmitter under test to 50 kHz above the VHF crystal filter centre frequency. Key the transmitter under test "on". Use the transmission generator to produce continuous maximum length Mode 2 messages.
- Step 4: Set the analyser span to 50 kHz and centre frequency to the centre frequency of the VHF crystal filter. Decrease the analyser input attenuator to the minimum level at which the attenuated RF signal from the transmitter under test does not overload the analyser. Use the analyser IF signal power as the trigger source for the display and set averaging to 10. .
- Step 5: Set analyser's power band marker function to 40 kHz. Notice that the measurement bandwidth is defined by the VHF crystal filter and setting the power band marker to the same bandwidth will give an erroneous result.
- Step 6: Determine the second lower adjacent channel power.
- Step 7: Repeat Steps 3 to 6 with the transmitter under test tuned to 50 kHz below the crystal filter. Determine the second upper adjacent channel power.
- Step 8: Record the second adjacent channel power as the highest of the two measured values.
- Step 9: Check that the second adjacent channel power is less than the second adjacent channel power requirement (defined in clause 6.2.8).
- Step 10: Repeat Steps 2 to 9 at the two remaining test frequencies

NOTE: To protect the analyser, ensure that the transmitter cannot be keyed "on", at the frequency of the crystal filter used for this test.

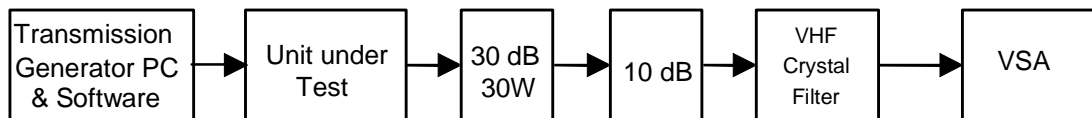

Figure 12: Second and fourth adjacent channel power measurement

9.2.7.3 Method of measurement for the fourth adjacent channel

The following equipment is required:

- Transmission Generator, PC with suitable software
- Attenuator 30 dB
- VHF crystal filter with a 3 dB bandwidth of 25 kHz and, with attenuation in excess of 50 dB at ± 50 kHz.
- Spectrum analyser with power band marker function.

The measurement procedure consists in the following steps:

- Step 1: Connect the equipment as shown in figure 12.
- Step 2: Tune the transmitter to one of the test frequencies
- Step 3: Offset the tuned frequency of the transmitter under test to 100 kHz above the VHF crystal filter centre frequency. Key the transmitter under test "on". Use the transmission generator to produce continuous maximum length Mode 2 messages.

- Step 4: Set the analyser span to 50 kHz and centre frequency to the centre frequency of the VHF crystal filter. Decrease the analyser input attenuator to the minimum level at which the attenuated RF signal from the transmitter under test does not overload the analyser. Use the analyser IF signal power as the trigger source for the display and set averaging to 10.
- Step 5: Set analyser's power band marker function set to 40 kHz. Notice that the measurement bandwidth is defined by the VHF crystal filter and setting the power band marker to the same bandwidth will give an erroneous result.
- Step 6: Determine the fourth lower adjacent channel power.
- Step 7: Repeat Steps 3 to 6 with the transmitter under test tuned to 100 kHz below the crystal filter. Determine the fourth upper adjacent channel power.
- Step 8: Record the fourth adjacent channel power as the highest of the two measured values.
- Step 9: Check that the fourth adjacent channel power is less than the fourth adjacent channel power requirement (defined in clause 6.2.8).
- Step 10: Repeat Steps 2 to 9 at the two remaining test frequencies

An alternative Measurement Procedure for Adjacent Channel Power (ACP) consists in the following steps:

- Step 1: Connect the equipment as shown in figure 12.
- Step 2: Tune the transmitter to one of the test frequencies
- Step 3: Start the transmission generator that produces transmit blocks and simulates the transmit/receive duty cycle
- Step 4: Use an attenuator to protect the measurement equipment and a notch filter centered on the carrier frequency, if the dynamic range of the spectrum analyser is not sufficient. Set the spectrum analyser resolution bandwidth (Br) much narrower than the channel bandwidth and the video bandwidth (Bv) equal to ten times Br in order to avoid errors due to video averaging of noise.
- Step 5: Measure and store the RF signal spectrum centered on the carrier frequency with a frequency span wide enough to display all the modulation spectrum between the -80 dB points, referred to the peak value.
- Step 6: Convert the logarithmic trace values from the spectrum analyser to linear spectral power densities by the relation:

$$P_i = \frac{10^{\frac{P_{idBm}}{10}}}{B_n}$$

where P_{idBm} = Trace values (dBm)

B_n = Effective noise bandwidth of the spectrum analyser (Hz)

P_i = Spectral power densities (mW/Hz)

NOTE: $B_n = k * B_r$, where k is a constant specified for each spectrum analyser.

- Step 7: Perform an integration of the linear spectral power densities. For computation of the linear spectral power values in the first, second and fourth adjacent channels, use the formula:

$$P_{ch} = B_{ch} \times \frac{1}{N} \times \sum_{i=1}^N P_i$$

where P_{ch} = power in the considered channel

B_{ch} = assigned bandwidth of the first, second or third adjacent channel.

N = Number of power samples within the limits of the assigned bandwidth, B_{ch} .

- Step 8: Perform the adjacent channel measurement for the first, second and fourth adjacent channels on both sides of the carrier frequency (lower and upper adjacent channels).
- Step 9: Check that the adjacent channel power on either side of the carrier for the first, second and fourth adjacent channels are lower than the respective adjacent channel power requirements (defined in clause 6.2.8).
- Step 10: Repeat Steps 2 to 9 at the two remaining test frequencies

9.2.8 Wideband noise (clause 6.2.9)

The following equipment is required:

- Transmission Generator, PC with suitable software
- Attenuator 30 dB
- Notch filter with a minimum of 30 dB on-channel attenuation
- Spectrum analyser with power band marker function.

The measurement procedure consists in the following steps:

- Step 1: Connect the equipment as shown in figure 13.
- Step 2: Tune the transmitter to one of the test frequencies
- Step 3: Use the filter to attenuate the carrier in order to increase the dynamic range of the measurement without overloading the spectrum analyser. Measure the frequency response of the filter and take this into account when presenting noise measurement results.
- Step 4: Key the transmitter under test using the transmission generator with repetitive maximum length Mode 2 messages.
- Step 5: Adjust the spectrum analyser reference level to provide the maximum dynamic range for display and set the input attenuator to minimum. Ensure that no signal at the analyser input exceeds the maximum allowable level.
- Step 6: Record the transmitter noise level versus the frequency displacement using the power band marker function of the analyser.
- Step 7: Check that the wide-band noise does not exceed the limit specified in clause 6.2.9.
- Step 8: Repeat Steps 2 to 7 at the two remaining test frequencies

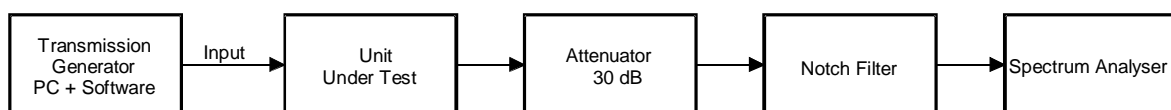

Figure: 13: Wideband noise measurement

9.2.9 Protection of the transmitter (clause 6.2.1)

9.2.9.1 Method of measurement

While the transmitter is transmitting at the rated output power, the antenna port shall first be short-circuited and then open-circuited, in each case for a period of 1 minute. This test shall be performed on the centre test frequency only.

9.2.9.2 Requirement

This test shall not result in any damage to the transmitter. After removal of the short-circuit and open-circuit conditions, the transmitter shall meet the requirements of the Performance check (clause 8.3.2).

9.2.10 Frequency Error (clause 6.2.10)

9.2.10.1 Definition

The frequency error is the difference between the measured carrier frequency and its nominal value.

9.2.10.2 Method of measurement

The carrier frequency shall be measured in the absence of modulation, with the transmitter connected to a coaxial termination. Measurements shall be made under extreme test conditions.

9.2.10.3 Limits

The frequency error shall be within +/- 2 ppm

9.3 Physical layer, system parameters

9.3.1 Receiver to Transmitter turn-around time (clause 6.3.1)

The following equipment is required:

The measurement procedure consists in the following steps:

- Step 1: Connect the equipment as shown in figure 14.
- Step 2: Tune the transmitter to one of the test frequencies
- Step 3: Configure the VSA to display Power versus Time, external trigger enabled.
- Step 4: Set the VHF signal generator to produce an on-channel CW signal of -80 dBm at the input to the equipment under test. Set the PIN diode attenuator to 0 dB.
- Step 5: Use the transmission generator to set the MAC parameters for the equipment under test:
 - TM1 (Inter-access delay) = 0.5 ms.
 - TM2 (Channel busy) = 120 seconds.
 - P (Persistence) = 1
 - M1 (Maximum no. of attempts) = 65535
- Step 6: Use the transmission generator to load the equipment under test with with a minimum length Mode-2 message and request transmission of the message by the equipment under test.
- Step 7: Use the computer control to set the pin diode attenuator to 20 dB and trigger the VSA.
- Step 8: Use the VSA to confirm the -20 dB signal attenuation "step" occurred in an insignificant time. Measure the time interval until between the step and commencement of transmission, determined by the transmitter output achieving 90 % of manufacturers declared output power (clause 6.2.2).
- Step 9: After accounting for the minimum Inter-access time (TM1) calculate the "turn-around" time. Check that the maximum receive to transmit turn-around time (clause 6.3.1) has not been exceeded.

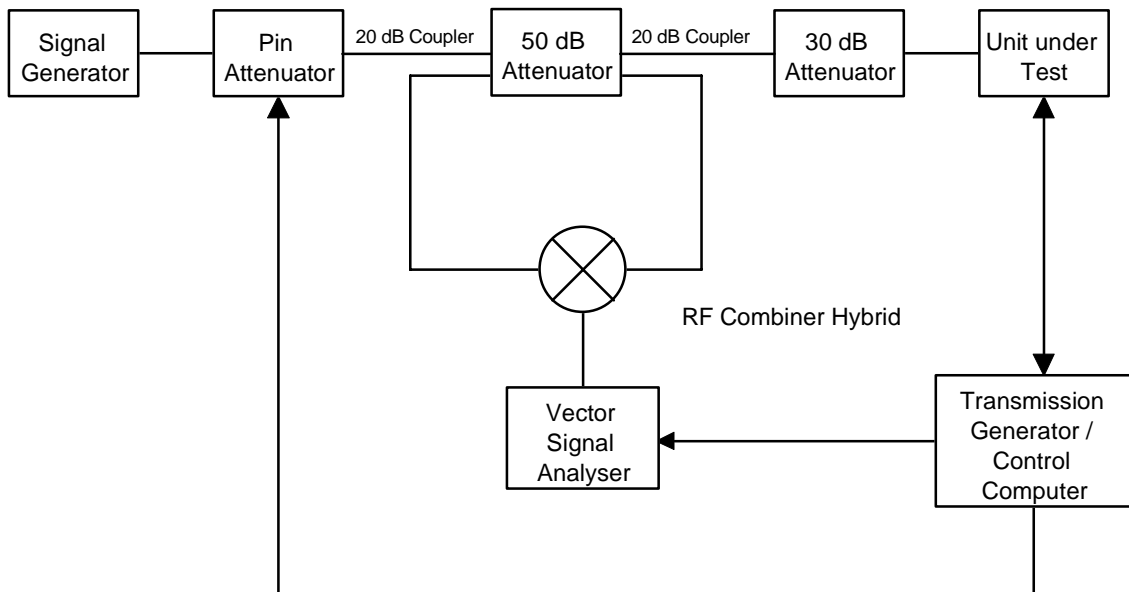

Figure 14: Receiver to transmitter turn-around measurement

9.3.2 Transmitter to Receiver turn-around time (clause 6.3.2)

Equipment Required

The measurement procedure consists in the following steps:

- Step 1: Connect the equipment as shown in figure 15.
- Step 2: Tune the transmitter to one of the test frequencies
- Step 3: Configure the VSA to display Power versus Time, external trigger enabled.
- Step 4: Set the signal generator to provide a signal of -60 dBm at the input of the equipment under test.
- Step 5: Load the AWG with a valid Mode-2 message.
- Step 6: Use the transmission generator to set the MAC parameters for the equipment under test:

TM1 (Inter-access delay) = 0.5 ms.

TM2 (Channel busy) = 120 seconds.

P (Persistence) = 1

M1 (Maximum no. of attempts) = 65,535

- Step 7: Load a minimum length Mode-2 message into the equipment under test. Request transmission of this message and trigger the VSA
- Step 8: Record the time interval between the trigger event and the cessation of transmission from the unit under test. Use the result to calculate the minimum time between the transmit request and the trigger event for the AWG.
- Step 9: Load the equipment under test with a minimum length Mode-2 message and request transmission.
- Step 10: Check whether the equipment under test had successfully received the transmission from the AWG.
- Step 11: If the AWG transmission was not correctly received, increase the AWG time delay and repeat step 7 to 10 until the equipment under test has successfully received the minimum length messages from the AWG.

Step 12: Check that the maximum transmit to receive turn-around time (clause 6.3.2) has not been exceeded.

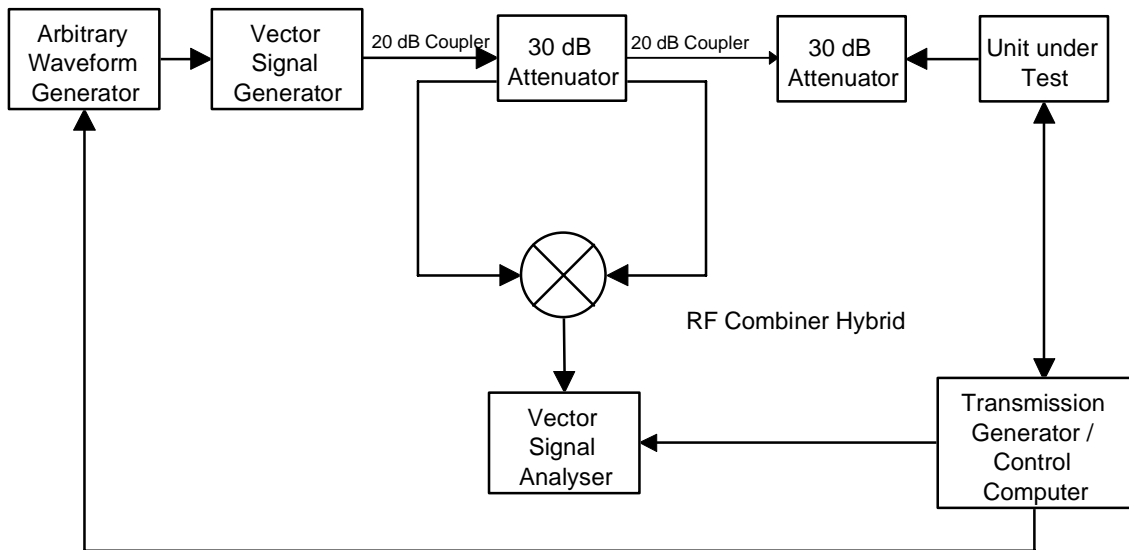

Figure: 15: Transmitter to receiver turn-around time measurement

History

Document history			
V1.1.3	May 2001	Public Enquiry	PE 20010907: 2001-05-09 to 2001-09-07