

ETSI EN 301 813-3 V1.1.1 (2002-02)

European Standard (Telecommunications series)

Integrated Services Digital Network (ISDN) and Broadband Integrated Services Digital Network (B-ISDN); Generic Addressing and Transport (GAT) protocol; Part 3: Test Suite Structure and Test Purposes (TSS&TP) specification



Reference

DEN/SPAN-130177-3

Keywords

B-ISDN, broadband, DSS1, functional, generic,
ISDN, protocol, testing, TSS&TP

ETSI

650 Route des Lucioles
F-06921 Sophia Antipolis Cedex - FRANCE

Tel.: +33 4 92 94 42 00 Fax: +33 4 93 65 47 16

Siret N° 348 623 562 00017 - NAF 742 C
Association à but non lucratif enregistrée à la
Sous-Préfecture de Grasse (06) N° 7803/88

Important notice

Individual copies of the present document can be downloaded from:

<http://www.etsi.org>

The present document may be made available in more than one electronic version or in print. In any case of existing or perceived difference in contents between such versions, the reference version is the Portable Document Format (PDF). In case of dispute, the reference shall be the printing on ETSI printers of the PDF version kept on a specific network drive within ETSI Secretariat.

Users of the present document should be aware that the document may be subject to revision or change of status. Information on the current status of this and other ETSI documents is available at

<http://portal.etsi.org/tb/status/status.asp>

If you find errors in the present document, send your comment to:

editor@etsi.fr

Copyright Notification

No part may be reproduced except as authorized by written permission.
The copyright and the foregoing restriction extend to reproduction in all media.

© European Telecommunications Standards Institute 2002.
All rights reserved.

Contents

| | |
|--|-----------|
| Intellectual Property Rights | 4 |
| Foreword..... | 4 |
| 1 Scope | 5 |
| 2 References | 5 |
| 3 Definitions and abbreviations..... | 5 |
| 3.1 Definitions related to conformance testing..... | 5 |
| 3.2 Definitions related to EN 301 813-1..... | 6 |
| 3.3 Abbreviations | 7 |
| 4 General Test Suite Structure (TSS) | 8 |
| 5 Test Suite Structures (TSSs) and Test Purposes (TPs)..... | 9 |
| 5.1 Introduction | 9 |
| 5.1.1 TP naming convention | 9 |
| 5.1.2 Source of TP definition..... | 9 |
| 5.1.3 TP structure..... | 10 |
| 5.1.4 Test strategy..... | 10 |
| 5.2 Sending GAT-Control TPs..... | 10 |
| 5.2.1 TPs for Basic Interconnection (BIT)..... | 10 |
| 5.2.2 TPs for Capability..... | 12 |
| 5.2.3 TPs for Valid Behaviour (BV)..... | 13 |
| 5.2.4 TPs for Invalid Behaviour (INV)..... | 14 |
| 5.2.5 TPs for Inopportune Behaviour (BO) | 14 |
| 5.3 Receiving Transit GAT-Control TPs..... | 14 |
| 5.3.1 TPs for Basic Interconnection (BIT)..... | 14 |
| 5.3.2 TPs for Capability..... | 14 |
| 5.3.3 TPs for Valid Behaviour (BV)..... | 15 |
| 5.3.4 TPs for Invalid Behaviour (INV)..... | 15 |
| 5.3.5 TPs for Inopportune Behaviour (BO) | 15 |
| 5.4 Receiving End GAT-Control TPs | 16 |
| 5.4.1 TPs for Basic Interconnection (BIT)..... | 16 |
| 5.4.2 TPs for Capability..... | 16 |
| 5.4.3 TPs for Valid Behaviour (BV)..... | 16 |
| 5.4.4 TPs for Invalid Behaviour (INV)..... | 17 |
| 5.4.5 TPs for Inopportune Behaviour (BO) | 17 |
| 5.4.6 Note | 17 |
| 5.5 Co-ordination Function TPs | 18 |
| 5.6 ROSE requirements | 18 |
| 6 Compliance..... | 19 |
| Annex A (informative): Applicability of Test Purposes | 20 |
| History | 22 |

Intellectual Property Rights

IPRs essential or potentially essential to the present document may have been declared to ETSI. The information pertaining to these essential IPRs, if any, is publicly available for **ETSI members and non-members**, and can be found in ETSI SR 000 314: "*Intellectual Property Rights (IPRs); Essential, or potentially Essential, IPRs notified to ETSI in respect of ETSI standards*", which is available from the ETSI Secretariat. Latest updates are available on the ETSI Web server (<http://webapp.etsi.org/IPR/home.asp>).

Pursuant to the ETSI IPR Policy, no investigation, including IPR searches, has been carried out by ETSI. No guarantee can be given as to the existence of other IPRs not referenced in ETSI SR 000 314 (or the updates on the ETSI Web server) which are, or may be, or may become, essential to the present document.

Foreword

This European Standard (Telecommunications series) has been produced by ETSI Technical Committee Services and Protocols for Advanced Networks (SPAN).

The present document is part 3 of a multi-part deliverable covering the Digital Subscriber Signalling System No. one (DSS1) and the Signalling System No. 7 (SS7) ISDN User Part (ISUP) protocol specifications for the Integrated Services Digital Network (ISDN), and the Digital Subscriber Signalling System No. two (DSS2) and Signalling System No. 7 (SS7) B-ISDN User Part (B-ISUP) protocol specifications for the Broadband Integrated Services Digital Network (B-ISDN) to support the Generic Addressing and Transport protocol (GAT), as identified below:

- Part 1: "Protocol specification [ITU-T Recommendation Q.860 (2000), modified]";
- Part 2: "Protocol Implementation Conformance Statement (PICS) proforma specification";
- Part 3: "Test Suite Structure and Test Purposes (TSS&TP) specification";**
- Part 4: "Abstract Test Suite (ATS) and partial Protocol Implementation eXtra Information for Testing (PIXIT) proforma specification".

| National transposition dates | |
|--|------------------|
| Date of adoption of this EN: | 1 February 2002 |
| Date of latest announcement of this EN (doa): | 31 May 2002 |
| Date of latest publication of new National Standard or endorsement of this EN (dop/e): | 30 November 2002 |
| Date of withdrawal of any conflicting National Standard (dow): | 30 November 2002 |

1 Scope

The present document specifies the Test Suite Structure and Test Purposes (TSS&TP) for both the Sending and the Receiving control of the Generic Addressing and Transport (GAT) based on ITU-T Recommendation Q.860 (06/2000), modified [9]. This GAT protocol is independent of the transport mechanism. This GAT protocol may operate indifferently through ISDN, B-ISDN or SS7 systems and may use either bearer related or bearer independent transport.

A further part of the present document specifies the Abstract Test Suite (ATS) and partial Protocol Implementation eXtra Information for Testing (PIXIT) proforma based on the present document.

2 References

The following documents contain provisions which, through reference in this text, constitute provisions of the present document.

- References are either specific (identified by date of publication and/or edition number or version number) or non-specific.
- For a specific reference, subsequent revisions do not apply.
- For a non-specific reference, the latest version applies.

- [1] ETSI EN 301 813-1 (V1.1.1): "Integrated Services Digital Network (ISDN) and Broadband Integrated Services Digital Network (B-ISDN); Generic Addressing and Transport (GAT) protocol; Part 1: Protocol specification [ITU-T Recommendation Q.860 (2000), modified]".
- [2] ETSI EN 301 813-2 (V1.1.1): "Integrated Services Digital Network (ISDN) and Broadband Integrated Services Digital Network (B-ISDN); Generic Addressing and Transport (GAT) protocol; Part 2: Protocol Implementation Conformance Statement (PICS) proforma specification".
- [3] ISO/IEC 9646-1: "Information technology - Open Systems Interconnection - Conformance testing methodology and framework - Part 1: General concepts".
- [4] ISO/IEC 9646-2: "Information technology - Open Systems Interconnection - Conformance testing methodology and framework - Part 2: Abstract Test Suite specification".
- [5] ITU-T Recommendation I.411 (1993): "ISDN user-network interfaces - Reference configurations".
- [6] ITU-T Recommendation X.229 (1988): "Remote Operations: Protocol specification".
- [7] ITU-T Recommendation I.112: "Vocabulary of terms for ISDNs".
- [8] ITU-T Recommendation X.880 (1994): "Information technology - Remote Operations: Concepts, model and notation".
- [9] ITU-T Recommendation Q.860 (2000): "Integrated Services Digital Network (ISDN) and Broadband Integrated Services Digital Network (B-ISDN) Generic Addressing and Transport (GAT) Protocol".

3 Definitions and abbreviations

For the purposes of the present document, the following terms and definitions apply.

3.1 Definitions related to conformance testing

abstract test case: Refer to ISO/IEC 9646-1 [3].

Abstract Test Suite (ATS): Refer to ISO/IEC 9646-1 [3].

Implementation Under Test (IUT): Refer to ISO/IEC 9646-1 [3].

Protocol Implementation Conformance Statement (PICS): Refer to ISO/IEC 9646-1 [3].

PICS proforma: Refer to ISO/IEC 9646-1 [3].

Protocol Implementation eXtra Information for Testing (PIXIT): Refer to ISO/IEC 9646-1 [3].

PIXIT proforma: Refer to ISO/IEC 9646-1 [3].

system under test: Refer to ISO/IEC 9646-1 [3].

Test Purpose (TP): Refer to ISO/IEC 9646-1 [3].

3.2 Definitions related to EN 301 813-1

AnyNode: Value for the sourceEntity and destinationEntity of the GAT network facility extension, such that (two cases exist):

- when specified without an address, the requested service functionality is to be provided at the next service provision point along the path of the transport mechanism that supports the service within the same or any subsequent service provider. For this value an end node acts to provide end GAT-Control functionality; or
- when specified with an associated address, the requested service functionality is to be provided at the next service provision point along the path of the transport mechanism within the same or any subsequent service provider that has the given address. Where the first service provision point that has the given address does not wish to provide the service, it can alter the address to that of another service provision point either within the same service provider or within a different service provider. For this value an end node that is not addressed discards the information.

Broadband Integrated Services Digital Network (B-ISDN): ISDN that supports rates greater than primary rate

Coincident S and T reference point: See ITU-T Recommendation I.411 [5].

End GAT-Control: entity located at the entity providing the destination service provision point

NOTE: It provides information to the application concerning the source of the service user APDUs (A pdu portion parameter), taken from the GAT-PDU, and passes the service user APDU to the application.

End node: node that is at either; the end point of the transport mechanism; or at the local exchange; whichever comes first along the path of the transport mechanism

EndNode: value for the sourceEntity and destinationEntity of the GAT network facility extension, such that the requested service functionality is to be provided at the last service provision point along the path of the transport mechanism before a terminal is reached

NOTE: This may be within the current service provider or in any subsequent service provider. For this value an end node acts to provide end GAT-Control functionality.

EndTerminal: value for the sourceEntity and destinationEntity of the GAT network facility extension, such that the requested service functionality is to be provided at the terminal along the path of the transport mechanism

NOTE: This terminal can be attached to the current service provider or to any subsequent service provider.

GAT Control: protocol entity supporting the GAT protocol

NOTE: It provides services to the GAT users, both directly and through ROSE, and uses the services of various underlying protocols (e.g. DSS1, ISUP) in order to provide the transport of those GAT user protocol data units.

GAT user: protocol entity that uses the services of the GAT protocol to transfer the GAT user protocol data units between the peer GAT user entities

Integrated Services Digital Network (ISDN): See ITU-T Recommendation I.112 [7], definition 308.

Receiving GAT-Control: entity that could be a point of service provision, which can be one of end GAT-Control, or transit GAT-Control

Sending GAT-Control: this entity is located at the entity providing the source service provision point

NOTE: It provides information from the application concerning the destination of the service user APDU, and passes the service user APDU (ApuPortion parameter) to the peer receiving GAT-Control entity.

Service address: address that identifies the service provision point

NOTE: This can be any valid address within the available numbering plan and is assigned by the service provider.

Service indicator: provides information to identify an ASE

Service provision point: node capable of providing service functionality, and where checking should therefore be performed to see if the specific requested service is provided

Service user APDU: APDU that is carried on behalf of another application within the generic addressing and transport protocol. It is encoded as an ApduPortion parameter within the GAT-PDU.

Terminal: equipment provided at the user side of the coincident S and T reference point

Transit exchange: public network exchange for which an incoming transport mechanism (bearer-related or bearer-independent) is received from a public network exchange in the same public network, and for which an outgoing transport mechanism (bearer-related or bearer-independent) is generated to a public network exchange in the same public network

Transit GAT-Control: exchange located within a network, and its function is to pass on service user APDUs (ApuPortion parameter) unchanged

Transport mechanism: mechanism, or one of a set of mechanisms, within the underlying protocol, for transporting transport parameters between GAT-control entities

Transport parameter: element of information transported by the transport mechanism on behalf of the GAT protocol

NOTE 1: The transport parameter carries the GAT-PDU and information identifying that the information relates to the GAT protocol, rather than some other application making use of the transport mechanism. Multiple transport parameters can occur within a transport PDU.

NOTE 2: Where the transport parameter is a Facility information element, the GAT protocol is identified by the protocol profile field. Where the transport parameter is an Application transport parameter, the GAT protocol is identified by the Application Context Identifier field.

3.3 Abbreviations

For the purposes of the present document, the following abbreviations apply:

| | |
|-------------|---|
| APDU | Application Protocol Data Unit |
| AS-ASE | Application Service-Application Service Element |
| ATM | Abstract Test Method |
| ATS | Abstract Test Suite |
| BIT | Basic Interconnection Tests |
| B-ISDN | Broadband-Integrated Services Digital Network |
| BO | Inopportune tests |
| BV | Behaviour Valid tests |
| CA | CApability |
| DSS1 | Digital Subscriber Signalling System No. one |
| DSS2 | Digital Subscriber Signalling System No. two |
| GAT | Generic Addressing and Transport |
| GAT-Control | Generic Addressing and Transport-Control |
| GAT-PDU | Generic Addressing and Transport Protocol Data Unit |
| INV | INValid behaviour tests |
| ISDN | Integrated Services Digital Network |
| ISUP | ISDN User Part |

| | |
|-------|---|
| IUT | Implementation Under Test |
| NNI | Network-Network Interface |
| PDU | Protocol Data Unit |
| PICS | Protocol Implementation Conformance Statement |
| PIXIT | Protocol Implementation eXtra Information for Testing |
| ROSE | Remote Operations Service Element |
| SS7 | Signalling System No. 7 |
| TP | Test Purpose |
| TSS | Test Suite Structure |
| UNI | User-Network Interface |

4 General Test Suite Structure (TSS)

Basic interconnection tests (BIT)

Basic interconnection tests form the basis of the other tests in the test suite and therefore have to be executed previously to all the other tests. The tests assure that the IUT provides the basic functionality to set up connections that shall be used in the rest of the test suite.

Capability tests (CA)

Capability testing provides a limited testing to ascertain the capabilities stated in the PICS can be observed.

Valid behaviour tests (BV)

There are no state and therefore no state transitions defined in EN 301 813-1 [1] are considered valid. The test purposes in the valid behaviour test group cover the verification of the procedures of the Sending GAT-Control and the Receiving GAT-Control. The messages and their contents offered to the IUT are syntactically and semantically valid.

Invalid behaviour tests (INV)

The test purposes in this test group verify that the IUT reacts correctly on receiving messages that are syntactically incorrect.

Inopportune behaviour tests (BO)

The test purposes in this test group verify that the IUT reacts correctly in the case inopportune protocol events occur. Such events are syntactically correct but occur when not expected.

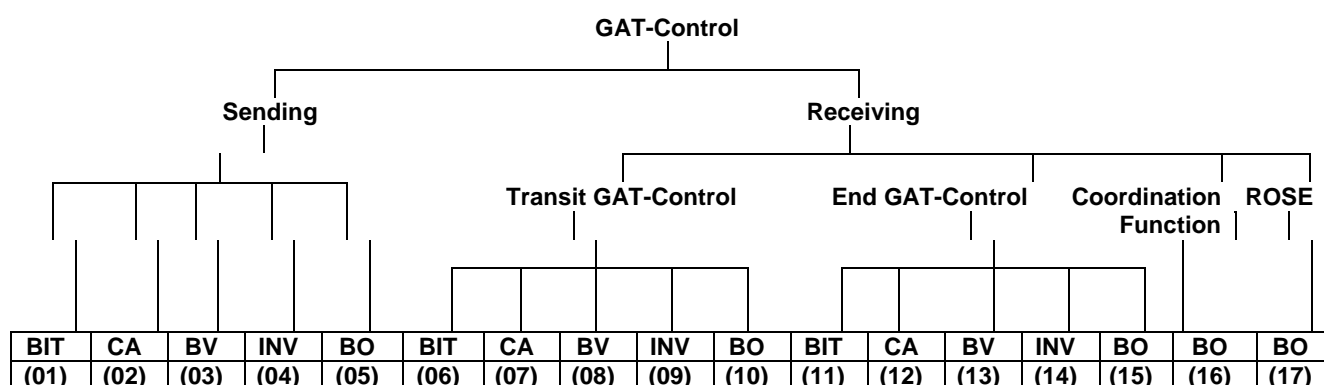

NOTE 1: Numbers in brackets represent group numbers and are used in TP identifiers.

NOTE 2: This TSS reflects only the normative part of the document.

NOTE 3: Clause numbers are the original ITU-T Recommendation Q.860 [9] clause numbers, are not used in the test purpose number but are referenced in the test purpose descriptions.

NOTE 4: Annex A is not part of EN 301 813-1 [1] while being part of ITU-T Recommendation Q.860 [9].

NOTE 5: Test purposes for receiving GAT-control that are not specific to either Transit or End-GAT control are included in the End GAT-Control group.

Figure 1: Test Suite Structure

5 Test Suite Structures (TSSs) and Test Purposes (TPs)

5.1 Introduction

For each test requirement a TP is defined.

5.1.1 TP naming convention

TPs are numbered, starting at 001, within each group. Groups are organized according to the TSS. Additional references are added to identify the actual test suite and whether it applies to the network or the user (see table 1).

Table 1: TP identifier naming convention scheme

| | | | | | | | | | | | | | |
|-------------------------------------|-----------------------|-----------------------------------|--|---|---------|----|-------------------|----|---------------|----|-----------------------|----|------|
| Identifier: <ss>_<iut><group>_<nnn> | | | | | | | | | | | | | |
| <ss> | = | supplementary service: e.g. "GAT" | | | | | | | | | | | |
| <iut> | = | type of IUT: | <table> <tr> <td>S</td> <td>Sending</td> </tr> <tr> <td>RT</td> <td>Receiving Transit</td> </tr> <tr> <td>RE</td> <td>Receiving End</td> </tr> <tr> <td>CF</td> <td>Coordination function</td> </tr> <tr> <td>RO</td> <td>ROSE</td> </tr> </table> | S | Sending | RT | Receiving Transit | RE | Receiving End | CF | Coordination function | RO | ROSE |
| S | Sending | | | | | | | | | | | | |
| RT | Receiving Transit | | | | | | | | | | | | |
| RE | Receiving End | | | | | | | | | | | | |
| CF | Coordination function | | | | | | | | | | | | |
| RO | ROSE | | | | | | | | | | | | |
| <group> | = | group | 2 digit field representing group reference according to TSS | | | | | | | | | | |
| <nnn> | = | sequential number | (001-999) | | | | | | | | | | |

5.1.2 Source of TP definition

The TPs are based on EN 301 813-1 [1].

5.1.3 TP structure

Each TP has been written in a manner which is consistent with all other TPs. The intention of this is to make the TPs more readable and checkable. A particular structure has been used and this is illustrated in table 2. This table should be read in conjunction with any TP, i.e. use a TP as an example to fully understand the table.

Table 2: Structure of a single TP

| TP part | Text | Example |
|-------------------|--|--|
| Header | <Identifier> tab <clause number in base EN> <i>tab</i> | see table 1 clause 0.0.0 |
| Stimulus | Ensure that the IUT <precondition> <trigger> <i>see below for message structure</i> <i>or</i> <goal> | as a terminal GAT-Control receiving a XXXX message to request a |
| Reaction | <action> <conditions> <i>if the action is sending</i> <i>see below for message structure</i> <next action>, etc. | sends, saves, passes, etc. |
| Message structure | GAT-PDU containing an APDU a) a Network Functional Extension information element with b) a <field name> encoded as or including <coding of the field> and <i>back to a or b</i> | Transport Mechanism |

5.1.4 Test strategy

As the base standard EN 301 813-1 [1] contains no explicit requirements for testing, the TPs were generated as a result of an analysis of the base standard and the PICS specification EN 301 813-2 [2]. The criteria applied include the following:

- whether or not a test case can be built from the TP is not considered.

5.2 Sending GAT-Control TPs

5.2.1 TPs for Basic Interconnection (BIT)

Selection: IUT supports the functions of a sending GAT-control entity. PICS: MC.1.

GAT_S_01_001 clause 9.1 table 3

Ensure that the IUT as a terminal GAT-Control, receiving a request to send an initial service user APDU to an end Node sends an APDU in a GAT-PDU over the transport mechanism containing as a destination entity endNode and containing no destination entity address.

Selection: IUT is a terminal. PICS: MC.8.

Selection: IUT supports communication with end node. PICS: SC.1.

GAT_S_01_002 clause 9.1 table 3

Ensure that the IUT as a network node GAT-Control, receiving a request to send an initial service user APDU to an end Node sends an APDU in a GAT-PDU over the transport mechanism containing as a destination entity endNode and containing no destination entity address.

Selection: IUT is a network node. PICS: NOT MC.8.

Selection: IUT supports communication with end node. PICS: SC.1.

GAT_S_01_003 clause 9.1 table 3

Ensure that the IUT as a terminal GAT-Control, receiving a request to send an initial service user APDU to an end Terminal sends an APDU in a GAT-PDU over the transport mechanism containing as a destination entity endTerminal and containing no destination entity address.

Selection: IUT is a terminal. PICS: MC.8.

Selection: IUT supports communication with end terminal. PICS: SC.2.

GAT_S_01_004 clause 9.1 table 3

Ensure that the IUT as a network node GAT-Control, receiving a request to send an initial service user APDU to an end Terminal sends an APDU in a GAT-PDU over the transport mechanism containing as a destination entity endTerminal and containing no destination entity address.

Selection: IUT is a network node. PICS: NOT MC.8.

Selection: IUT supports communication with end terminal. PICS: SC.2.

GAT_S_01_005 clause 9.1 table 3

Ensure that the IUT as a terminal GAT-Control, receiving a request to send an initial service user APDU to an addressed node sends an APDU in a GAT-PDU over the transport mechanism NFE containing as a destination entity AnyNode and containing the service address.

Selection: IUT is a terminal. PICS: MC.8.

Selection: IUT supports communication with an addressed node. PICS: SC.3.

GAT_S_01_006 clause 9.1 table 3

Ensure that the IUT as a network node GAT-Control, receiving a request to send an initial service user APDU to an addressed node ,sends an APDU in a GAT-PDU over the transport mechanism NFE containing as a destination entity AnyNode and containing the service address.

Selection: IUT is a network node. PICS: NOT MC.8.

Selection: IUT supports communication with an addressed node. PICS: SC.3.

GAT_S_01_007 clause 9.1 table 3

Ensure that the IUT as a terminal GAT-Control, receiving a request to send an initial service user APDU to the next node which understands the APDU, sends an APDU in a GAT-PDU over the transport mechanism NFE containing as a destination entity AnyNode and containing no destination entity address.

Selection: IUT is a terminal. PICS: MC.8.

Selection: IUT supports communication with the next node which understands contents. PICS: SC.4.

GAT_S_01_008 clause 9.1 table 3

Ensure that the IUT as a network node GAT-Control, receiving a request to send an initial service user APDU to the next node which understands the APDU sends an APDU in a GAT-PDU over the transport mechanism NFE containing as a destination entity AnyNode and containing no destination entity address.

Selection: IUT is a network node. PICS: NOT MC.8.

Selection: IUT supports communication with the next node which understands contents. PICS: SC.4.

GAT_S_01_009 clause 9.1 table 3

Ensure that the IUT as a terminal GAT-Control, receiving a request to send an initial service user APDU to the next entity, without explicit indication of the origin or destination of the APDU, sends an APDU in a GAT-PDU over the transport mechanism containing no GAT network facility extension.

Selection: IUT is a terminal. PICS: MC.8.

Selection: IUT supports communication with the next entity. PICS: SC.4.

GAT_S_01_010 clause 9.1 table 3

Ensure that the IUT as a network node GAT-Control, receiving a request to send an initial service user APDU to the next entity, without explicit indication of the origin or destination of the APDU, sends the APDU in a GAT-PDU over the transport mechanism containing no network facility element.

Selection: IUT is a network node. PICS: NOT MC.8.

Selection: IUT supports communication with the next entity. PICS: SC.4.

5.2.2 TPs for Capability

Selection: IUT supports the functions of a sending GAT-control entity. PICS: MC.1.

GAT_S_02_001 table 4

Ensure that IUT as an End node sending GAT-Control, receiving a request to send a service user APDU to a terminal sends a GAT APDU in a GAT-PDU over the transport mechanism containing as source entity EndNode and containing no source entity address.

Selection: IUT is an End Node. PICS: MC.9.

GAT_S_02_002 table 4

Ensure that IUT as an End node sending GAT-Control, receiving a request to send a service user APDU to a network node sends a GAT APDU in a GAT-PDU over the transport mechanism containing as source entity EndNode and containing no source entity address.

Selection: IUT is an End Node. PICS: MC.9.

GAT_S_02_003 table 4

Ensure that IUT as an End terminal sending GAT-Control, receiving a request to send a service user APDU to a terminal sends a GAT APDU in a GAT-PDU over the transport mechanism containing as source entity EndTerminal and containing no source entity address.

Selection: IUT is a terminal. PICS: MC.8.

GAT_S_02_004 table 4

Ensure that IUT as an End terminal sending GAT-Control, receiving a request to send a service user APDU to a network node sends a GAT APDU in a GAT-PDU over the transport mechanism containing as source entity EndTerminal and containing no source entity address.

Selection: IUT is a terminal. PICS: MC.8.

GAT_S_02_005 table 4

Ensure that IUT as sending GAT-Control, receiving a request to send a service user APDU to a network node, indicating the origin of the service APDU by the service address, sends the APDU in a GAT-PDU over the transport mechanism containing as source entity AnyNode and containing as source entity address the service address.

Selection: IUT is a network node. PICS: NOT MC.8.

GAT_S_02_006 table 4

Ensure that IUT as sending GAT-Control, receiving a request to send a service user APDU to a terminal, indicating the origin of the APDU by the service address, sends the APDU in a GAT-PDU over the transport mechanism containing as source entity AnyNode and containing as source entity address the service address.

Selection: IUT is a network node. PICS: NOT MC.8.

GAT_S_02_07 table 4

Ensure that IUT sending GAT-Control when responding to a service user APDU received with DestinationEntity EndNode, with no Destination entity address, with a source entity AnyNode and a Source Entity address yyyy, sends as destinationEntity AnyNode, as destinationEntityAddress yyyy in the GAT NFE, as sourceEntity EndNode in the GAT NFE and with no sourceEntityAddress and sends as the serviceIndicator field, the serviceIndicator field that accompanied the service user APDU being responded to.

Selection: IUT supports the functions of a receiving GAT-control entity. PICS: MC.2.

Selection: IUT is an End Node. PICS: MC.9.

GAT_S_02_08 table 4

Ensure that IUT sending GAT-Control when responding to a service user APDU received with DestinationEntity AnyNode, with Destination entity address xxxx, with a source entity EndNode and no Source Entity address, sends in the GAT NFE as destinationEntity EndNode, with no destinationEntityAddress, as sourceEntity AnyNode and as sourceEntityAddress xxxx and sends as the serviceIndicator field, the serviceIndicator field that accompanied the service user APDU being responded to.

Selection: IUT supports the functions of a receiving GAT-control entity. PICS: MC.2.

Selection: IUT is a network node. PICS: NOT MC.8.

GAT_S_02_09 table 4

Ensure that IUT sending GAT-Control when responding to a service user APDU received with DestinationEntity AnyNode, with Destination entity address xxxx, with a source entity AnyNode and with a Source Entity address yyyy, sends in the GAT NFE as destinationEntity AnyNode, with destinationEntityAddress yyyy, as sourceEntity AnyNode and as sourceEntityAddress xxxx and sends as the serviceIndicator field, the serviceIndicator field that accompanied the service user APDU being responded to..

Selection: IUT supports the functions of a receiving GAT-control entity. PICS: MC.2.

Selection: IUT is a network node. PICS: NOT MC.8.

GAT_S_02_010 table 4

Ensure that IUT sending GAT-Control when responding to a service user APDU received with DestinationEntity AnyNode, with no Destination entity address, with a source entity EndNode and with no Source Entity address, sends in the GAT NFE as destinationEntity EndNode, with no destinationEntityAddress, as sourceEntity AnyNode and no sourceEntityAddress and sends as the serviceIndicator field, the serviceIndicator field that accompanied the service user APDU being responded to.

Selection: IUT supports the functions of a receiving GAT-control entity. PICS: MC.2.

Selection: IUT is an End Node. PICS: MC.9.

GAT_S_02_011 table 4

Ensure that IUT as a terminal GAT-Control when responding to a service user APDU received with DestinationEntity endTerminal, with no Destination entity address, with a source entity anyNode and a Source Entity address yyyy, sends in the GAT NFE as destinationEntity anyNode, as destinationEntityAddress yyyy, as sourceEntity endTerminal with no sourceEntityAddress and sends as the serviceIndicator field, the serviceIndicator field that accompanied the service user APDU being responded to.

Selection: IUT supports the functions of a receiving GAT-control entity. PICS: MC.2.

Selection: IUT is a terminal. PICS: MC.8.

GAT_S_02_012 table 4

Ensure that IUT as a terminal GAT-Control when responding to a service user APDU received with DestinationEntity endTerminal, with no Destination entity address, with a source entity endNode and a Source Entity address yyyy, sends in the GAT NFE as destinationEntity endNode, with no destinationEntityAddress, as sourceEntity endTerminal with no sourceEntityAddress and sends as the serviceIndicator field, the serviceIndicator field that accompanied the service user APDU being responded to.

Selection: IUT supports the functions of a receiving GAT-control entity. PICS: MC.2.

Selection: IUT is a terminal. PICS: MC.8.

5.2.3 TPs for Valid Behaviour (BV)

Selection: IUT supports the functions of a sending GAT-control entity. PICS: MC.1.

GAT_S_03_001 clause 5.4.2 b)

Ensure that IUT, after having received a syntactically correct GAT-Set-up in an AS-ASE primitive request for a transport mechanism service using DSS1 replies with a GAT-Reject when the transport mechanism asked for in that primitive (DSS1) is not available or not supported.

NOTE 1: This could be tested indifferently on bearer-related service or bearer-independent service.

Selection: IUT does not support operation over DSS1. PICS: NOT MC.5.

GAT_S_03_002 clause 5.4.2 b)

Ensure that IUT, after having received a syntactically correct GAT-Set-up in an AS-ASE primitive request for a transport mechanism service using DSS2 replies with a GAT-Reject when the transport mechanism asked for in that primitive (DSS2) is not available or not supported.

NOTE 2: This could be tested indifferently on bearer-related service or bearer-independent service.

Selection: IUT does not support operation over DSS2. PICS: NOT MC.6.

GAT_S_03_003 clause 5.4.2 b)

Ensure that IUT, after having received a syntactically correct GAT-Set-up in an AS-ASE primitive request for a transport mechanism service using SS7 replies with a GAT-Reject when the transport mechanism asked for in that primitive (SS7) is not available or not supported.

Selection: IUT does not support operation over SS7. PICS: NOT MC.7.

GAT_S_03_004 clauses 5.4.2 b) and 5.3

Ensure that IUT, after having received a syntactically correct GAT-Set-up in an AS-ASE primitive request for a transport mechanism service using a bearer related service replies with a GAT-Reject when the transport mechanism asked for in that primitive (bearer related) is not available or not supported.

NOTE 3: This applies indifferently to DSS1, DSS2 or SS7 and could be tested on any of the three network layer.

Selection: IUT does not support operation over a bearer-related transport. PICS: NOT MC.3.

GAT_S_03_005 clauses 5.4.2 b) and 5.3

Ensure that IUT, after having received a syntactically correct GAT-Set-up in an AS-ASE primitive request for a transport mechanism service using connection-oriented bearer-independent service replies with a GAT-Reject when the transport mechanism asked for in that primitive (connection-oriented bearer-independent) is not available or not supported.

NOTE 4: This applies indifferently to DSS1, DSS2 or SS7 and could be tested on any of the three network layers.

Selection: IUT does not support operation over bearer-independent transport. PICS: NOT MC.4.

5.2.4 TPs for Invalid Behaviour (INV)

None identified.

5.2.5 TPs for Inopportune Behaviour (BO)

None identified.

5.3 Receiving Transit GAT-Control TPs

5.3.1 TPs for Basic Interconnection (BIT)

None identified.

5.3.2 TPs for Capability

Selection: IUT supports the functions of a receiving transit GAT-control entity. PICS: MC 14.

GAT_RT_07_001 clause 9.3

Ensure that the IUT as a Transit GAT-Control, on receiving via GFP a GAT-PDU including an NFE with a destinationEntity element indicating "EndTerminal" and with no destinationEntityAddress element GAT-PDU, passes it unchanged via GFP to the next node.

5.3.3 TPs for Valid Behaviour (BV)

The TPs in this clause refer to clause 9.3.

NOTE: Where TPs refer to "understanding the contents of that GAT-PDU" this means that the IUT can determine that the application to which the APDU relates is present in the SUT by examination of the service indicator or operation values within the APDU portion of the GAT-PDU.

Selection: IUT supports the functions of a receiving transit GAT-control entity. PICS: MC.14.

GAT_RT_08_001 clause 9.3

Ensure that the IUT as a Transit GAT-Control , on receiving via GFP a GAT-PDU including an NFE with a destinationEntity element indicating "EndNode" and with no destinationEntityAddress element, passes it unchanged via GFP to the next Node.

GAT_RT_08_002 clause 9.3

Ensure that the IUT as a Transit GAT-Control , on receiving via GFP a GAT-PDU containing a ROSE APDU of type InvokePDU including an NFE with a destinationEntity element indicating "AnyNode" and with a destinationEntityAddress element not matching its own address, and understanding the contents of that GAT-PDU, passes it unchanged via GFP to the next Node.

GAT_RT_08_003 clause 9.3

Ensure that the IUT as a Transit GAT-Control , on receiving via GFP a GAT-PDU containing a ROSE APDU of type InvokePDU including an NFE with a destinationEntity element indicating "AnyNode" and with a destinationEntityAddress element not matching its own address, and not understanding the contents of that GAT-PDU, passes it unchanged via GFP to the next Node.

GAT_RT_08_004 clause 9.3

Ensure that the IUT as a Transit GAT-Control , on receiving via GFP a GAT-PDU containing a ROSE APDU of type InvokePDU including an NFE with a destinationEntity element indicating "AnyNode" and with no destinationEntityAddress element, and not understanding the contents of that GAT-PDU, passes it unchanged via GFP to the next Node.

5.3.4 TPs for Invalid Behaviour (INV)

Selection: IUT supports the functions of a receiving transit GAT-control entity. PICS: MC.2 and MC.12.

GAT_RT_09_001 clause 9.3

Ensure that the IUT as a Transit GAT-Control, on receiving via GFP a GAT-PDU including an NFE with a destinationEntity element indicating "EndTerminal" and with a destinationEntityAddress element not matching its own address, passes it removing the Destination Address via GFP to the next Node.

Selection: IUT supports the functions of a receiving transit GAT-control entity. PICS: MC.2 and MC.12.

5.3.5 TPs for Inopportune Behaviour (BO)

GAT_RT_10_001 clause 9.3

Ensure that the IUT as a Transit GAT-Control, on receiving a GAT-PDU including an NFE with a destinationEntity element indicating "EndNode" and with a destinationEntityAddress element not matching its own address, passes it removing the Destination Address to the next Node.

GAT_RT_10_002 clause 9.3

Ensure that the IUT as a Transit GAT-Control, on receiving via GFP a GAT-PDU including an NFE with a destinationEntity element indicating "EndNode" and with a destinationEntityAddress element matching its own address, passes it removing the Destination Address via GFP to the next Node.

5.4 Receiving End GAT-Control TPs

5.4.1 TPs for Basic Interconnection (BIT)

Selection: IUT supports the functions of a receiving GAT-control entity. PICS: MC.2.

GAT_RT_11_001 clause 9.2

Ensure that the IUT, on receiving via GFP a GAT-PDU not including a Network Facility Extension (NFE), becomes the Destination Entity for that IE and passes it to the CF.

5.4.2 TPs for Capability

Selection: IUT supports the functions of a receiving GAT-control entity. PICS: MC.2.

GAT_RE_12_001 clause 9.4

Ensure that the IUT as an End GAT-Control, on receiving via GFP a GAT-PDU including an NFE with a destinationEntity element indicating "AnyNode" and with no destinationEntityAddress element, and understanding the contents of that GAT-PDU, becomes the Destination Entity for that GAT-PDU and passes it to the Co-ordination Function.

NOTE: Where TPs refer to "understanding the contents of that GAT-PDU" this means that the IUT can determine that the application to which the APDU relates is present in the SUT by examination of the service indicator or operation values within the APDU portion of the GAT-PDU.

5.4.3 TPs for Valid Behaviour (BV)

Selection: IUT supports the functions of a receiving GAT-control entity. PICS: MC.2.

GAT_RE_13_001 clause 9.4

Ensure that the IUT as an End GAT-Control, on receiving via GFP a GAT-PDU including an NFE with a destinationEntity element indicating "endNode" and with no destinationEntityAddress element, becomes the Destination Entity for that GAT-PDU and passes it to the Co-ordination Function.

Selection: IUT is an End Node. PICS: MC.9.

GAT_RE_13_002 clause 9.4

Ensure that the IUT as an End GAT-Control, on receiving via GFP a GAT-PDU including an NFE with a destinationEntity element indicating "AnyNode" and with a destinationEntityAddress element matching its own address, becomes the Destination Entity for that GAT-PDU and passes it to the Co-ordination Function.

Selection: IUT is a network node. PICS: NOT MC.8.

NOTE: The following test purposes apply only to the case of the Receiving GAT-Control located at a terminal.

GAT_RE_13_003 clause 9.2.2

Ensure that IUT, receiving an address contained within the destinationEntityAddress field in association with an EntityType with a value "endTerminal" ignores the received address.

Selection: IUT is a terminal. PICS: MC.8.

GAT_RE_13_004 clause 9.2.2

Ensure that IUT, receiving a first and only APDU which is a GAT-PDU, which is correctly coded and which contains a destinationEntity field with any other value than "endTerminal" discards the APDU portion received within the transport parameter and does not perform any further processing on the information within that transport parameter.

Selection: IUT is a terminal. PICS: MC.8.

5.4.4 TPs for Invalid Behaviour (INV)

Selection: IUT supports the functions of a receiving GAT-control entity. PICS: MC.2.

GAT_RE_14_001 clauses 9.2.2 and 9.2.3

Ensure that IUT, when receiving a first and only APDU which is not a GAT PDU, disregards the content of the transport parameter and does not process further that received information.

GAT_RE_14_002 clauses 9.2.2 and 9.2.3

Ensure that the IUT as a receiving GAT-Control, on receiving via GFP a GAT-PDU which includes an NFE not encoded or structured according to EN 301 813-1 [1], discards the entire GAT-PDU, without either passing it on via GFP to the next Node or passing it to an AS-ASE or unrecognized ASE handling function.

GAT_RE_14_003 clause 9.5.2

Ensure that IUT, receiving an Interpretation APDU that is not the first APDU in the sequence of APDUs received ignores the received Interpretation APDU.

5.4.5 TPs for Inopportune Behaviour (BO)

GAT_RE_15_001 clause 9.4

Ensure that the IUT as an End GAT-Control, on receiving via GFP a GAT-PDU including an NFE with a destinationEntity element indicating "anyNode" and with a destinationEntityAddress element not matching its own address, discards the GAT-PDU.

Selection: IUT is a network node. PICS: NOT MC.8.

GAT_RE_15_002 clause 9.4

Ensure that the IUT as an End GAT-Control, on receiving via GFP a GAT-PDU including an NFE with a destinationEntity element indicating "endNode" and with a destinationEntityAddress element matching its own address, becomes the Destination Entity for that GAT-PDU and passes it to the Co-ordination Function.

Selection: IUT is an End Node. PICS: MC.9.

GAT_RE_15_003 clause 9.4

Ensure that the IUT as an End GAT-Control, on receiving via GFP a GAT-PDU including an NFE with a destinationEntity element indicating "endNode" and with a destinationEntityAddress element not matching its own address, becomes the Destination Entity for that GAT-PDU and passes it to the Co-ordination Function.

5.4.6 Note

NOTE: The coverage of the possible combinations of NFE coding by the above TPs is shown in table 3.

Table 3: Possible combinations of NFE coding

| DestinationEntity element (note 1) | DestinationEntity Address element (note 2) | Capable (note 3) | Action (note 4) | TP (note 5) |
|------------------------------------|--|------------------|-----------------|-------------|
| End | match | - | N | RT_10_003 |
| End | no match | - | N | RT_10_001 |
| End | - | - | N | RT_08_001 |
| Any | match | - | D | RE_13_002 |
| Any | no match | yes | N | RT_08_002 |
| Any | - | yes | D | RE_12_001 |
| Any | no match | no | N | RT_08_003 |
| Any | - | no | N | RT_08_004 |

NOTE 1: The destinationEntity element of the NFE indicates "EndNode" (End) or "AnyNode" (Any).
 NOTE 2: The destinationEntityAddress element of the NFE matches the IUT's address (match) or does not match the IUT's address (not match).
 NOTE 3: The IUT is able to become an End Node for that GAT-PDU.
 NOTE 4: The IUT becomes a Destination Entity for that GAT-PDU (D), or passes this Facility unchanged to the next Node (N).
 NOTE 5: The TP dealing with the corresponding situation has the number identified in this column (e.g. RT_08_003, etc.).

5.5 Co-ordination Function TPs

Selection: IUT supports the functions of a receiving GAT-control entity. PICS: MC.2.

GAT_CF_16_001 clause 9.5.2

Ensure that the IUT, on receiving from ROSE an APDU of type RejectPDU with an "InvokeProblem" encoded as "unrecognizedOperation" resulting from the processing of a sequence of APDUs received from GAT-CONTROL, where the first one of the sequence was an InterpretationAPDU encoded as "rejectUnrecognizedInvokePdu", and where another one of the sequence was an InvokePDU which caused the rejection, requests GAT-Control to send a GAT-PDU with the APDU of type RejectPDU received from ROSE.

Selection: IUT supports the functions of a sending GAT-control entity. PICS: MC.1.

GAT_CF_16_002 clause 9.5.2

Ensure that the IUT, on receiving from ROSE an APDU of type RejectPDU with an "InvokeProblem" encoded as "unrecognizedOperation" resulting from the processing of a sequence of APDUs received from GAT-CONTROL, with no InterpretationAPDU, and whose one APDU was an InvokePDU which caused the rejection, requests GAT-Control to send a GAT-PDU with the APDU of type RejectPDU received from ROSE.

Selection: IUT supports the functions of a sending GAT-control entity. PICS: MC.1.

GAT_CF_16_003 clause 9.5.2

Ensure that the IUT, on receiving from ROSE an APDU of type RejectPDU with an "InvokeProblem" encoded as "unrecognizedOperation" resulting from the processing of a sequence of APDUs received from GAT-CONTROL, where the first one of the sequence was an InterpretationAPDU encoded as "clearCallIfAnyInvokePduNotRecognized", and where another one of the sequence was an InvokePDU which caused the rejection, requests GAT-Control to send a GAT-PDU with the APDU of type RejectPDU received from ROSE and to clear the underlying transport mechanism.

Selection: IUT supports the functions of a sending GAT-control entity. PICS: MC.1.

GAT_CF_16_004 clause 9.5.2

Ensure that the IUT, on receiving from ROSE an APDU of type RejectPDU with an "InvokeProblem" encoded as "unrecognizedOperation" resulting from the processing of a sequence of APDUs received from GAT-CONTROL, where the first one of the sequence was an InterpretationAPDU encoded as "discardAnyUnrecognizedInvokePdu", and where another one of the sequence was an InvokePDU which caused the rejection, does not request GAT-Control to send a GAT-PDU with the APDU of type RejectPDU received from ROSE.

5.6 ROSE requirements

The TPs in this clause refer to clause 9.5.2 and ITU-T Recommendation X.229 [6], clause 7.

Selection: IUT supports the functions of a receiving GAT-control entity. PICS: MC.2.

GAT_RO_17_001 clause 9.5.2,

ITU-T Recommendation X.229 [6], clauses 7.1.3.2 and 7.4.3.1 or ITU-T Recommendation X.880 [8], clause 9.3.

Ensure that the IUT, on receiving via CF an APDU of type InvokePDU with an unrecognized operation value, requests CF to send an APDU of type RejectPDU with the invokeID field encoded as in the incoming APDU and the "problem" field encoded as "unrecognizedOperation".

6 Compliance

An ATS which complies with this TSS&TP specification shall:

- a) consist of a set of test cases corresponding to the set or to a subset of the TPs specified in clause 6;
- b) use a TSS which is an appropriate subset of the whole of the TSS specified in clause 5;
- c) use the same naming conventions for the test groups and test cases;
- d) maintain the relationship specified in clause 6 between the test groups and TPs and the entries in the PICS proforma to be used for test case deselection;
- e) comply with ISO/IEC 9646-2 [4].

In the case of a) or b) above, a subset shall be used only where a particular Abstract Test Method (ATM) makes some TPs untestable. All testable TPs from clause 6 shall be included in a compliant ATS.

Annex A (informative): Applicability of Test Purposes

In the context of any particular connection a GAT entity can be considered perform one of six different roles. These are illustrated in figure A.1, which shows the various scenarios that are possible.

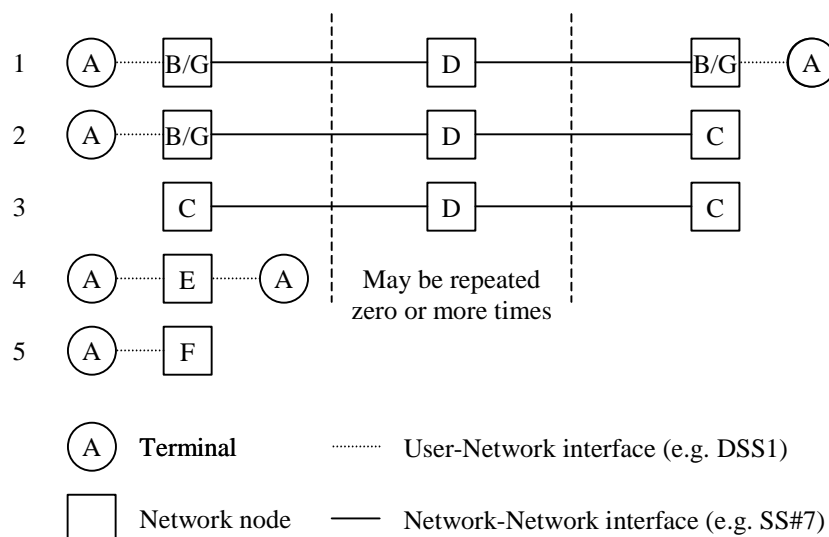

Figure A.1: Connection scenarios

- Role A is a terminal, which is at an endpoint of a connection and is connected to one other GAT entity over a UNI.
- Role B/G is a network node, acting as a local exchange, which is connected to one GAT entity in a terminal over a UNI and one GAT entity in another network node over a NNI.
- Role C is a network node which is an endpoint of a connection and is connected to one other GAT entity over a NNI.
- Role D is a network node, acting as a transit exchange, which is connected to two other network nodes over two NNIs.
- Role E is a network node, acting as a local exchange, which is connected to two terminals over two UNIs.
- Role F is a network node, acting as a local exchange, which is connected to one terminal over one NNI.

A terminal can only carry out role A.

A network node can, in principle, carry out any of the roles B/G, C, D, E or F. In practice a particular network node implementation will not necessarily be able to carry out all the roles due to matters outside the scope of GAT. The role that an implementation performs for a particular connection is determined by addressing information used when establishing the connection and routing information held in the network node. Re-configuration would not be required to change the role being performed by the implementation (it is however possible that an implementation can support different configurations in which different roles are possible).

The behaviour of GAT differs according to the role being performed by the GAT entity, and therefore not all TPs are applicable to all roles. In some cases this is explicit in the test purpose (e.g. TPs explicitly testing terminal behaviour are only applicable to role A) whereas in other cases it is implicit (e.g. TPs testing relaying of GAT PDUs can only be applied to roles involving two interfaces). The roles to which each TP is applicable are indicated in table A.1.

Role B/G is asymmetrical and in some cases the required behaviour depends on which interface a GAT PDU is received on. Therefore in table A.1 role B/G is treated as two separate roles – role B where the focus of the test is on the UNI and role G where it is on the NNI.

Table A.1: Applicability of Test Purposes to roles

| Test Purpose | Role | | | | | | |
|---------------|------|------|---|---|------|------|------|
| | A | B | C | D | E | F | G |
| GAT_S_01_001 | X | | | | | | |
| GAT_S_01_002 | | | X | X | | | X |
| GAT_S_01_003 | X | | | | | | |
| GAT_S_01_004 | | X | X | X | X | X | X |
| GAT_S_01_005 | X | | | | | | |
| GAT_S_01_006 | | | X | X | | | X |
| GAT_S_01_007 | X | | | | | | |
| GAT_S_01_008 | | | X | X | | | X |
| GAT_S_01_009 | X | | | | | | |
| GAT_S_01_010 | | X | X | X | X | X | X |
| GAT_S_02_001 | | | X | | X | X | X |
| GAT_S_02_002 | | | X | | | | X |
| GAT_S_02_003 | X | | | | | | |
| GAT_S_02_004 | X | | | | | | |
| GAT_S_02_005 | | | X | X | | | X |
| GAT_S_02_006 | | X | X | X | X | X | X |
| GAT_S_02_007 | | note | X | | note | note | X |
| GAT_S_02_008 | | note | X | X | note | note | X |
| GAT_S_02_009 | | note | X | X | note | note | X |
| GAT_S_02_010 | | note | X | X | note | note | X |
| GAT_S_02_011 | X | | | | | | |
| GAT_S_02_012 | X | | | | | | |
| GAT_S_03_001 | X | | X | | | X | |
| GAT_S_03_002 | X | | X | | | X | |
| GAT_S_03_003 | X | | X | | | X | |
| GAT_S_03_004 | X | | X | | | X | |
| GAT_S_03_005 | X | | X | | | X | |
| GAT_RT_07_001 | | X | | X | X | | X |
| GAT_RT_08_001 | | X | | X | | | |
| GAT_RT_08_002 | | X | | X | note | | note |
| GAT_RT_08_003 | | X | | X | note | | note |
| GAT_RT_08_004 | | X | | X | note | | note |
| GAT_RT_09_001 | | X | | X | X | | X |
| GAT_RT_10_001 | | X | | X | | | |
| GAT_RT_10_002 | | X | | X | | | |
| GAT_RE_11_001 | X | X | X | X | X | X | X |
| GAT_RE_12_001 | | X | X | X | X | X | X |
| GAT_RE_13_001 | | | X | | X | X | X |
| GAT_RE_13_002 | | X | X | X | X | X | X |
| GAT_RE_13_004 | X | | | | | | |
| GAT_RE_13_005 | X | | | | | | |
| GAT_RE_14_001 | X | X | X | X | X | X | X |
| GAT_RE_14_002 | X | X | X | X | X | X | X |
| GAT_RE_14_003 | X | X | X | X | X | X | X |
| GAT_RE_15_001 | | | X | | X | X | X |
| GAT_RE_15_002 | | | X | | X | X | X |
| GAT_RE_15_003 | | | X | | X | X | X |
| GAT_CF_16_001 | X | X | X | X | X | X | X |
| GAT_CF_16_002 | X | X | X | X | X | X | X |
| GAT_CF_16_003 | X | X | X | X | X | X | X |
| GAT_CF_16_004 | X | X | X | X | X | X | X |
| GAT_RO_17_001 | X | X | X | X | X | X | X |

NOTE: These TP/role combinations cover situations where a GAT PDU cannot be delivered and are therefore considered inappropriate for testing.

History

| Document history | | | |
|-------------------------|---------------|----------------|---------------------------------------|
| V1.1.1 | July 2001 | Public Enquiry | PE 20011109: 2001-07-11 to 2001-11-09 |
| V1.1.1 | December 2001 | Vote | V 20020201: 2001-12-03 to 2002-02-01 |
| V1.1.1 | February 2002 | Publication | |
| | | | |
| | | | |