

ETSI EN 301 786 V1.1.2 (2001-05)

European Standard (Telecommunications series)

**Fixed Radio Systems;
Point-to-point equipment;
Parameters for digital radio systems
for the transmission of digital signals
operating at 52 GHz**



Reference

DEN/TM-04094

Keywords

Digital, DRRS, transmission, point-to-point, radio

ETSI

650 Route des Lucioles
F-06921 Sophia Antipolis Cedex - FRANCE

Tel.: +33 4 92 94 42 00 Fax: +33 4 93 65 47 16

Siret N° 348 623 562 00017 - NAF 742 C
Association à but non lucratif enregistrée à la
Sous-Préfecture de Grasse (06) N° 7803/88

Important notice

Individual copies of the present document can be downloaded from:

<http://www.etsi.org>

The present document may be made available in more than one electronic version or in print. In any case of existing or perceived difference in contents between such versions, the reference version is the Portable Document Format (PDF). In case of dispute, the reference shall be the printing on ETSI printers of the PDF version kept on a specific network drive within ETSI Secretariat.

Users of the present document should be aware that the document may be subject to revision or change of status. Information on the current status of this and other ETSI documents is available at <http://www.etsi.org/tb/status/>

If you find errors in the present document, send your comment to:
editor@etsi.fr

Copyright Notification

No part may be reproduced except as authorized by written permission.
The copyright and the foregoing restriction extend to reproduction in all media.

© European Telecommunications Standards Institute 2001.
All rights reserved.

Contents

Intellectual Property Rights	5
Foreword.....	5
1 Scope.....	6
2 References.....	7
3 Symbols and abbreviations.....	9
3.1 Symbols.....	9
3.2 Abbreviations.....	9
4 General characteristics	10
4.1 Frequency bands and channel arrangements.....	10
4.1.1 Channel arrangements.....	10
4.1.2 Co-polar channel spacing for systems operating on the same route.....	10
4.2 Compatibility requirements between systems	10
4.3 Performance and availability requirements.....	11
4.4 Environmental conditions	11
4.4.1 Equipment within weather protected locations (indoor locations).....	11
4.4.2 Equipment for non-weather protected locations (outdoor locations).....	11
4.5 Power supply.....	11
4.6 Electromagnetic compatibility	11
4.7 System block diagram	12
4.8 Telecommunications Management Network (TMN) interface.....	12
4.9 Branching/feeder/antenna characteristics.....	12
4.9.1 Antenna radiation patterns.....	12
4.9.2 Antenna cross-Polar Discrimination (XPD)	12
4.9.3 Antenna Inter-Port Isolation (IPI).....	12
4.9.4 Waveguide flanges (or other connectors).....	12
4.9.5 Return Loss (RL)	12
5 Parameters for Digital System.....	13
5.1 Transmission capacity	13
5.2 Baseband parameters	13
5.2.1 Plesiochronous interfaces	13
5.2.2 SDH baseband interface.....	13
5.3 Transmitter characteristics.....	13
5.3.1 Transmitter power range	14
5.3.2 Transmit power and frequency control.....	14
5.3.2.1 Automatic Transmit Power Control (ATPC).....	14
5.3.2.2 Remote Transmit Power Control (RTPC).....	14
5.3.2.3 Remote Frequency Control (RFC).....	14
5.3.3 Transmitter output power tolerance	14
5.3.4 Transmit Local Oscillator (LO) frequency arrangements.....	14
5.3.5 RF spectrum mask.....	14
5.3.6 Spectral lines at the symbol rate	16
5.3.7 Spurious emissions.....	16
5.3.7.1 Spurious emissions - external.....	16
5.3.7.2 Spurious emissions - internal	16
5.3.8 Radio frequency tolerance.....	17
5.4 Receiver characteristics	17
5.4.1 Input level range	17
5.4.2 Receiver local oscillator frequency arrangements.....	17
5.4.3 Spurious emissions.....	17
5.4.3.1 Spurious emissions - external.....	17
5.4.3.2 Spurious emissions - internal	17
5.5 System performance without diversity	17
5.5.1 BER as a function of Receiver input Signal Level (RSL)	17

5.5.2	Residual BER	18
5.5.3	Interference sensitivity	19
5.5.3.1	Co-channel interference sensitivity.....	19
5.5.3.2	Adjacent channel interference	20
5.5.3.3	Continuous Wave (CW) spurious interference.....	20
5.5.3.4	Front-end non-linearity requirements (two-tone CW spurious interference).....	21
5.5.4	Distortion sensitivity	21
5.6	System characteristics with diversity.....	21
Annex A (informative): Additional information		22
A.1	Radio frequency channel arrangement.....	22
A.2	RBER.....	23
A.3	Co-channel and adjacent channel interference	24
Annex B: Void		26
Annex C (normative): System type codes for regulatory procedures		27
History		28

Intellectual Property Rights

IPRs essential or potentially essential to the present document may have been declared to ETSI. The information pertaining to these essential IPRs, if any, is publicly available for **ETSI members and non-members**, and can be found in ETSI SR 000 314: "*Intellectual Property Rights (IPRs); Essential, or potentially Essential, IPRs notified to ETSI in respect of ETSI standards*", which is available from the ETSI Secretariat. Latest updates are available on the ETSI Web server (<http://www.etsi.org/ipr>).

Pursuant to the ETSI IPR Policy, no investigation, including IPR searches, has been carried out by ETSI. No guarantee can be given as to the existence of other IPRs not referenced in ETSI SR 000 314 (or the updates on the ETSI Web server) which are, or may be, or may become, essential to the present document.

Foreword

This European Standard (Telecommunications series) has been produced by ETSI Technical Committee Transmission and Multiplexing (TM).

The present document specifies the minimum performance parameters for radio equipment operating in the frequency ranges as detailed in clause 4.1.1.

The former title of the present document was "Transmission and Multiplexing; Digital Radio Relay Systems; Parameters for the DRRS for the transmission of digital signals operating at 52 GHz".

National transposition dates	
Date of adoption of this EN:	4 May 2001
Date of latest announcement of this EN (doa):	31 August 2001
Date of latest publication of new National Standard or endorsement of this EN (dop/e):	28 February 2002
Date of withdrawal of any conflicting National Standard (dow):	28 February 2002

1 Scope

The present document specifies the minimum performance parameters for terrestrial digital fixed service radio communications equipments operating in the 52 GHz frequency band and provides for the following:

- introduction of unique system type codes for regulatory reference to the various system types detailed in the present document, refer to new annex C (normative) and related categories of equipment classes of spectral efficiency;
- payload capacities for spectrum efficiency classes 1 to 4;
- digital services operating in frequency division duplex (FDD) operation only;
- technical specifications relevant to the EMC Directive, detailed in annex B (normative);
- specific antenna radiation patterns as defined in EN 300 833 [11]).

As harmonized channel spacings lower than 14 MHz are not defined in the 52 GHz frequency band at the drafting date of the present document, channel spacings at 7 MHz and 3,5 MHz are shown for information purposes only.

However the present document can be considered as a guideline when national frequency plans based on 7 MHz and 3,5 MHz channel spacings exist.

Digital systems are intended to be used for point-to-point connections in local and regional networks at data rates between 2 Mbit/s and Synchronous Transport Module, level 1 (STM-1).

Digital systems considered in the present document will be able to meet the error performance objectives of the ITU-R national portion of the reference path, i.e. ITU-R Recommendation F.1189 [18] and the error performance objectives detailed in ITU-T Recommendation G.826 [25].

The parameters to be specified fall into two categories:

- a) those that are required to provide compatibility between channels from different sources of equipment on the same route, connected to separate antennas;
- b) parameters defining the transmission quality of the proposed system.

The present document deals with Radio Frequency (RF) and baseband characteristics relevant to low, medium and high capacity Plesiochronous Digital Hierarchy (PDH) transmission systems, and STM-0 and STM-1 Synchronous Digital Hierarchy (SDH) transmission systems. Antenna/feeder system requirements are covered in EN 300 833 [11].

The present document does not contain aspects related to test procedures and test conditions however they are to be found in EN 301 126-1 [3].

As the maximum transmission rate in a given bandwidth depends on system spectral efficiency, different equipment classes are defined:

- | | |
|----------|---|
| Class 1: | equipment spectral efficiency based on typically 2-states modulation scheme (e.g. 2-FSK, Gaussian Minimum Shift Keying (GMSK) with discriminator detection, or equivalent); |
| Class 2: | equipment spectral efficiency based on typically 4-states modulation scheme (e.g. 4-FSK, 4-QAM, or equivalent); |
| Class 3: | equipment spectral efficiency based on typically 8-states modulation scheme (e.g. 8PSK, or equivalent); |
| Class 4: | equipment spectral efficiency based on typically 16 or 32-states modulation scheme (e.g. 16-QAM, 32-QAM, or equivalent). |

The above classes are indicative only and do not imply any constraint to the actual modulation format, provided that all the requirements in the present document are met.

Safety aspects are not be considered in the present document. However compliance to CENELEC EN 60950 [33] will be required to comply with the 1999/5/EC Directive (R&TTE).

Technical background for most of the parameters and requirements referred in the present document may be found in TR 101 036-1 [13]

2 References

The following documents contain provisions which, through reference in this text, constitute provisions of the present document.

- References are either specific (identified by date of publication, edition number, version number, etc.) or non-specific.
- For a specific reference, subsequent revisions do not apply.
- For a non-specific reference, the latest version applies.
- A non-specific reference to an ETS shall also be taken to refer to later versions published as an EN with the same number.

- [1] CEPT /ERC Recommendation 12-11 E (Luxembourg 1999): "Radio frequency channel arrangement for fixed service systems operating in the band 51.4 GHz - 52.6 GHz".
- [2] CEPT/ERC Recommendation 74-01: "Spurious emissions".
- [3] ETSI EN 301 126-1 (V1.1.2): "Fixed Radio Systems; Conformance testing; Part 1: Point-to-point equipment - Definitions, general requirements and test procedures".
- [4] ETSI ETS 300 019: "Equipment Engineering (EE); Environmental conditions and environmental tests for telecommunications equipment".
- [5] ETSI ETS 300 132-1: "Equipment Engineering (EE); Power supply interface at the input to telecommunications equipment; Part 1: Operated by alternating current (ac) derived from direct current (dc) sources".
- [6] ETSI ETS 300 132-2: "Equipment Engineering (EE); Power supply interface at the input to telecommunications equipment; Part 2: Operated by direct current (dc)".
- [7] ETSI EN 300 385: "Electromagnetic compatibility and Radio spectrum Matters (ERM); ElectroMagnetic Compatibility (EMC) standard for fixed radio links and ancillary equipment".
- [8] ETSI ETS 300 635: "Transmission and Multiplexing (TM); Synchronous Digital Hierarchy (SDH); Radio specific functional blocks for transmission of Mx STM-N".
- [9] ETSI EN 300 645: "Telecommunications Management Network (TMN); Synchronous Digital Hierarchy (SDH) radio relay equipment; Information model for use on Q interfaces".
- [10] ETSI ETS 300 785: "Transmission and Multiplexing (TM); Synchronous Digital Hierarchy (SDH); Radio specific functional blocks for transmission of M x sub-STM-1".
- [11] ETSI EN 300 833: "Fixed Radio Systems; Point to Point Antennas; Antennas for point-to-point fixed radio systems operating in the frequency band 3 GHz to 60 GHz".
- [12] ETSI TR 101 035 (V1.1.3): "Transmission and multiplexing (TM); Synchronous Digital Hierarchy (SDH) aspects regarding Digital Radio Relay Systems (DRRS)".
- [13] ETSI TR 101 036-1 (V1.2.1): "Fixed Radio Systems; Point-to-point equipment; Generic wordings for standards on digital radio systems characteristics; Part 1: General aspects and point-to-point equipment parameters".
- [14] IEC 60154-2: "Flanges for waveguides. Part 2: Relevant specifications for flanges for ordinary rectangular waveguides".

- [15] ITU-R Recommendation F.750: "Architectures and functional aspects of radio-relay systems for SDH-based networks".
- [16] ITU-R Recommendation F.751: "Transmission characteristics and performance requirements of radio-relay systems for SDH-based networks".
- [17] ITU-R Recommendation F.1102: "Characteristics of radio-relay systems operating in frequency bands above about 17 GHz".
- [18] ITU-R Recommendation F.1189: "Error performance objectives for constant bit rate digital paths at or above the primary rate carried by digital radio-relay systems which may form part or all of the national portion of a 27 500 km hypothetical reference path".
- [19] ITU-R Recommendation F.1191: "Bandwidths and unwanted emissions of digital radio-relay systems".
- [20] ITU-T Recommendation G.703: "Physical/electrical characteristics of hierarchical digital interfaces".
- [21] ITU-T Recommendation G.707: "Network node interface for the synchronous digital hierarchy (SDH)".
- [22] ITU-T Recommendation G.773: "Protocol suites for Q-interfaces for management of transmission systems".
- [23] ITU-T Recommendation G.783: "Characteristics of synchronous digital hierarchy (SDH) equipment functional blocks".
- [24] ITU-T Recommendation G.784: "Synchronous digital hierarchy (SDH) management".
- [25] ITU-T Recommendation G.826: "Error performance parameters and objectives for international, constant bit rate digital paths at or above the primary rate".
- [26] ITU-T Recommendation G.828: "Error performance parameters and objectives for international synchronous digital paths".
- [27] ITU-T Recommendation G.861: "Principles and guidelines for the integration of satellite and radio systems in SDH transport networks".
- [28] ITU-T Recommendation G.957: "Optical interfaces for equipments and systems relating to the synchronous digital hierarchy".
- [29] ITU-T Recommendation O.151: "Error performance measuring equipment operating at the primary rate and above".
- [30] ITU-T Recommendation O.181: "Equipment to assess error performance on STM-N interfaces".
- [31] ITU-R Recommendation P.530-6: "Propagation data and prediction methods required for the design of terrestrial line-of-sight systems".
- [32] Council Directive 89/336/EEC of 3 May 1989 on the approximation of the laws of the Member States relating to electromagnetic compatibility.
- [33] CENELEC EN 60950: "Safety of information technology equipment".
- [34] ITU-R Recommendations SM.329-8: "Spurious emissions".

3 Symbols and abbreviations

3.1 Symbols

For the purposes of the present document, the following symbols apply:

dB	decibel
dBi	decibel relative to isotropic radiator
dBm	decibel relative to 1 mW
dBu	decibel relative to 1microVolt
dBW	decibel relative to 1 W
GHz	GigaHertz
kHz	kiloHertz
Mbit/s	Mega-bits per second
MHz	MegaHertz
ppm	parts per million
mW	milliWatt
Ω	Ohm

3.2 Abbreviations

For the purposes of the present document, the following abbreviations apply:

ac	alternating current
ATPC	Automatic Transmit Power Control
AU	Administrative Unit
BBER	Background Block Error Rate
BER	Bit Error Rate
C/I	Carrier to Interference ratio
CMI	Coded Mark Inversion
CW	Continuous Wave
dc	direct current
DRRS	Digital Radio Relay Systems
EIRP	Equivalent Isotropically Radiated Power
EMC	ElectroMagnetic Compatibility
ESR	Errored Second Ratio
FDD	Frequency Division Duplex
FSK	Frequency-Shift Keying (modulation)
GMSK	Gaussian Minimum Shift Keying (modulation)
IEC	International Electrotechnical Committee
IF	Intermediate Frequency
IPI	Inter-Port Isolation
LO	Local Oscillator
n.a.	not applicable
PDH	Plesiochronous Digital Hierarchy
PRBS	Pseudo Random Binary Sequence
QAM	Quadrature Amplitude Modulation
RBER	Residual Bit Error Rate
RF	Radio Frequency
RFC	Remote Frequency Control
RL	Return Loss
RSL	Receive Signal Level
RTPC	Remote Transmit Power Control
SDH	Synchronous Digital Hierarchy
SOH	Section OverHead
STM-N	Synchronous Transport Module, level N
STM-0	medium capacity SDH radio transport module (51,840 Mbit/s AU-3 equivalent, also referred as STM-0 by ITU-T Recommendation G.861 [27])
TC	ETSI Technical Committee

TM ETSI TC-Transmission and Multiplexing
 TMN Telecommunications Management Network
 XPD cross-Polar Discrimination

4 General characteristics

4.1 Frequency bands and channel arrangements

4.1.1 Channel arrangements

The equipment shall operate on one or more of the channels as defined below:

The frequency range shall be 51,4 GHz to 52,6 GHz. The channel arrangements shall be in accordance with CEPT/ERC Recommendation 12-11 E (Luxembourg 1999) [1].

Harmonized channel spacings below 14 MHz are not currently defined in the 52 GHz CEPT channel plan. Therefore channel spacings at 7 MHz and 3,5 MHz are shown for information purposes only although these can be considered as a guide for national frequency plans based on 7 MHz and 3,5 MHz channel spacings."

For reader convenience, the basic parameters of the CEPT Recommendation are shown in informative annex A.

4.1.2 Co-polar channel spacing for systems operating on the same route

System bit rates and their relevant channel spacing in the present document are reported in table 1 (for the precise payload bit rates, see clause 5.1).

Table 1: Digital systems channel spacing for various bit rates

		Payload Bit Rate [Mbit/s]⇒	2	2 × 2	8	2 × 8	34	51	140 and 155
Channel Spacing [MHz]	Class 1 equipments		7	7	14	28	56		
	Class 2 equipments		3,5	3,5	7	14	28	56	
	Class 3 equipment							28	
	Class 4 equipment				3,5	7	14	14	56
NOTE: n x 2 Mbit/s and n x 34 Mbit/s bit rates may be used where appropriate.									

For regulatory purposes in national procedures for licensing radio equipment according to the present document, the above system types shall be identified by the "system type codes" reported in normative annex C.

4.2 Compatibility requirements between systems

The compatibility requirements between systems are as follows:

- there shall be no requirement to operate transmitting equipment from one manufacturer with receiving equipment from another;
- there shall not be a requirement to multiplex different manufacturers equipment on the same or on different polarization of the same antenna;
- depending on the application, it shall be possible to operate the system in vertical and/or horizontal polarization, if required by the channel arrangement.

4.3 Performance and availability requirements

Digital equipment shall be designed in order to meet network performance and availability requirements foreseen by ITU-T Recommendation G.826 [25] and ITU-T Recommendation G.828 [26] when published, following the criteria defined in ITU-R Recommendations F.1189 [18] for the national portion of the digital connection.

The implication of the link design on the performance is recognized and the general design criteria reported in ITU-R Recommendations P.530-6 [31] and F.1102 [17] shall be applied.

4.4 Environmental conditions

The equipment shall be required to meet the environmental conditions set out in ETS 300 019 [4] which defines weather protected and non-weather protected locations, classes and test severity. The manufacturer shall state which class the equipment is designed to withstand.

4.4.1 Equipment within weather protected locations (indoor locations)

Equipment intended for operation within temperature controlled locations or partially temperature controlled locations shall meet the requirements of ETS 300 019 [4] classes 3.1 and 3.2 respectively.

Optionally, the more stringent requirements of ETS 300 019 [4] classes 3.3 (non-temperature controlled locations), 3.4 (sites with heat trap) and 3.5 (sheltered locations) may be applied.

4.4.2 Equipment for non-weather protected locations (outdoor locations)

Equipment intended for operation within non-weather protected locations shall meet the requirements of ETS 300 019 [4], class 4.1 or 4.1E.

Class 4.1 applies to many European countries and class 4.1E applies to all European countries.

4.5 Power supply

The power supply interface shall be in accordance with the characteristics of one or more of the secondary voltages foreseen in ETS 300 132-1 [5] and ETS 300 132-2 [6].

NOTE: Some applications may require secondary voltages (e.g. 24 or 60V) that are not covered by ETS 300 132-1 [5] or ETS 300 132-2 [6].

4.6 Electromagnetic compatibility

Equipment shall operate under the conditions specified in EN 300 385 [7].

4.7 System block diagram

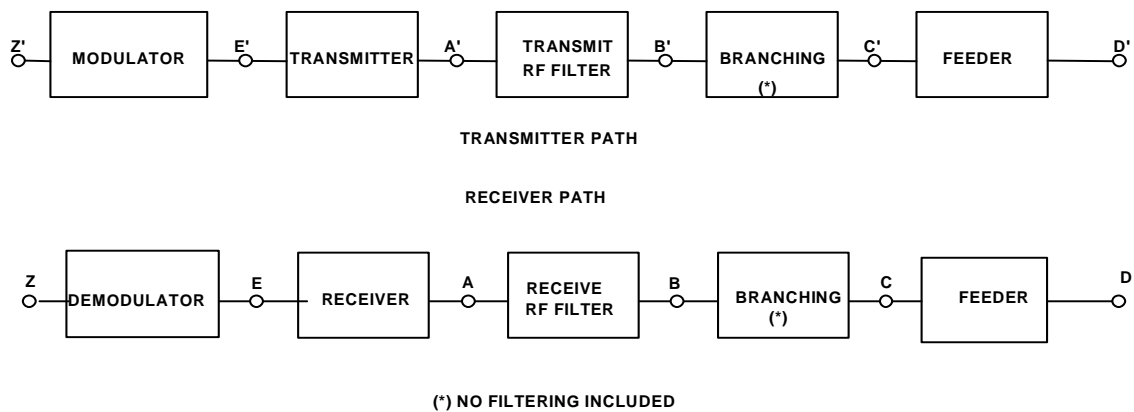

NOTE 1: For the purpose of defining the measurement points, the branching network does not include a hybrid.

NOTE 2: The points shown above are reference points only; points C and C', D and D' in general coincide.

NOTE 3: Points B and C, B' and C' may coincide when simple duplexer is used.

Figure 1: System block diagram

4.8 Telecommunications Management Network (TMN) interface

For SDH equipment ITU-T Recommendations G.784 [24] and G.773 [22] and ITU-R Recommendations F.750 [15] and F.751 [16] give the general requirements for TMN interface and functionality. ETS 300 635 [8], ETS 300 785 [10] and EN 300 645 [9] give the radio specific functional block description and the related radio fragment information model respectively.

NOTE: The standardization of TMN interface functionality is under study in ETSI TMN, and will be applicable to the radio relay systems considered in the present document.

4.9 Branching/feeder/antenna characteristics

4.9.1 Antenna radiation patterns

See EN 300 833 [11].

4.9.2 Antenna cross-Polar Discrimination (XPD)

See EN 300 833 [11].

4.9.3 Antenna Inter-Port Isolation (IPI)

See EN 300 833 [11].

4.9.4 Waveguide flanges (or other connectors)

When flanges are required at reference point C, C', the following shall be used according to IEC 154-2 [14]:

- UBR/PBR-620, for the complete frequency range.

4.9.5 Return Loss (RL)

Equipments according to the present document are likely to have integral antennas or very similar technical solutions, without long feeder connections; RL is not considered an essential requirement.

5 Parameters for Digital System

5.1 Transmission capacity

Payload bit rates considered in the present document are:

- 2,048 Mbit/s;
- $2 \times 2,048$ Mbit/s;
- 8,448 Mbit/s;
- $2 \times 8,448$ Mbit/s;
- 34,368 Mbit/s;
- 51,840 Mbit/s (STM-0);
- 139,264 Mbit/s; and
- 155,520 Mbit/s (STM-1).

System rates configured as n-times 2 Mbit/s or n-times 8 Mbit/s are also considered.

In the following clauses, these capacities will be simply referred as 2 Mbit/s, 2×2 Mbit/s, 8 Mbit/s, 2×8 Mbit/s, 34 Mbit/s, 51 Mbit/s (STM-0), 140 Mbit/s, and 155 Mbit/s (STM-1) respectively.

5.2 Baseband parameters

All the following specified baseband parameters refer to point Z and Z' of figure 1.

Parameters for service channels and wayside traffic channels are outside the scope of the present document.

5.2.1 Plesiochronous interfaces

Plesiochronous interfaces at 2 Mbit/s, 8 Mbit/s, 34 Mbit/s and 140 Mbit/s shall comply with ITU-T Recommendation G.703 [20].

5.2.2 SDH baseband interface

The SDH baseband interface shall be in accordance with ITU-T Recommendations G.703 [20], G.707 [21], G.783 [23], G.784 [24] and G.957 [28] and ITU-R Recommendations F.750 [15] and F.751 [16].

Two STM-1 interfaces shall be possible:

- Coded Mark Inversion (CMI) electrical (ITU-T Recommendation G.703 [20]); and
- Optical (ITU-T Recommendation G.957 [28]).

The use of reserved bytes contained in the Section Overhead (SOH), and their termination shall be in accordance with ITU-R Recommendations F.750 [15], F.751 [16].

NOTE: Further details on the possible use of the SOH bytes reserved for future international standardization are given in TR 101 035 [12]

5.3 Transmitter characteristics

The specified transmitter characteristics shall be met with the appropriate baseband signals applied at reference point Z' of figure 1. For PDH interface this shall be a Pseudo Random Binary Sequence (PRBS) according ITU-T Recommendation O.151 [29] while for SDH interface ITU-T Recommendation O.181 [30] test signal applies.

5.3.1 Transmitter power range

The maximum Equivalent Isotropically Radiated Power (EIRP) shall be less than +60 dBm. Transmitter maximum mean output power at reference point C' of the system block diagram (figure 1) shall not exceed +10 dBm (including tolerance).

Regulatory administrations may define nominal sub-ranges below this maximum limit.

NOTE: The technological evolution may result in equipment falling outside of the range(s) foreseen in this clause. In this case the equipments of different output power sub-ranges are not considered to require individual type approval, however their use is subject to individual national agreements.

A capability for output power level adjustment may be required for regulatory purposes, in which case the range of adjustment, either by fixed or automatic attenuators, should be in steps of 5 dB or less.

5.3.2 Transmit power and frequency control

5.3.2.1 Automatic Transmit Power Control (ATPC)

There is no requirement for ATPC with the equipment subject to the present document.

5.3.2.2 Remote Transmit Power Control (RTPC)

There is no requirement for RTPC with the equipment subject to the present document.

5.3.2.3 Remote Frequency Control (RFC)

RFC is an optional feature. Equipment with RFC will be subject to manufacturer declaration of RFC ranges and related change frequency procedure. Testing shall be carried out including:

- RFC setting procedure at least for three frequencies (lower, centre and higher of the covered range);
- RFC setting procedure shall not produce emissions outside the previous and final frequency spectrum mask.

5.3.3 Transmitter output power tolerance

The nominal output power shall be declared by the supplier.

The tolerance of the nominal output power shall be within ± 3 dB.

5.3.4 Transmit Local Oscillator (LO) frequency arrangements

There shall be no requirement on LO frequency arrangement.

5.3.5 RF spectrum mask

The spectrum masks are shown in figure 2 and do not include frequency tolerance.

The 0 dB level shown on the spectrum mask relates to the spectral power density of the nominal centre frequency disregarding residual carrier.

The mask shall be measured with a modulating base-band signal given by a PRBS signal given in ITU-T Recommendation O.151 [29] in the case of PDH signal or ITU-T Recommendation O.181 [30] in the case of STM-1 signal.

The recommended spectrum analyser settings for measuring the RF spectrum mask detailed in figure 2 are shown in the table 2.

Table 2: Spectrum analyser settings for RF power spectrum measurement

Channel Spacing [MHz]	3,5	7	14	28	56
Centre Frequency	Actual	Actual	Actual	Actual	Actual
Sweep width [MHz]	20	40	80	160	320
Scan time	Auto	Auto	Auto	Auto	Auto
IF bandwidth [kHz]	30	30	30	100	100
Video bandwidth [kHz]	0,1	0,3	0,3	0,3	0,3

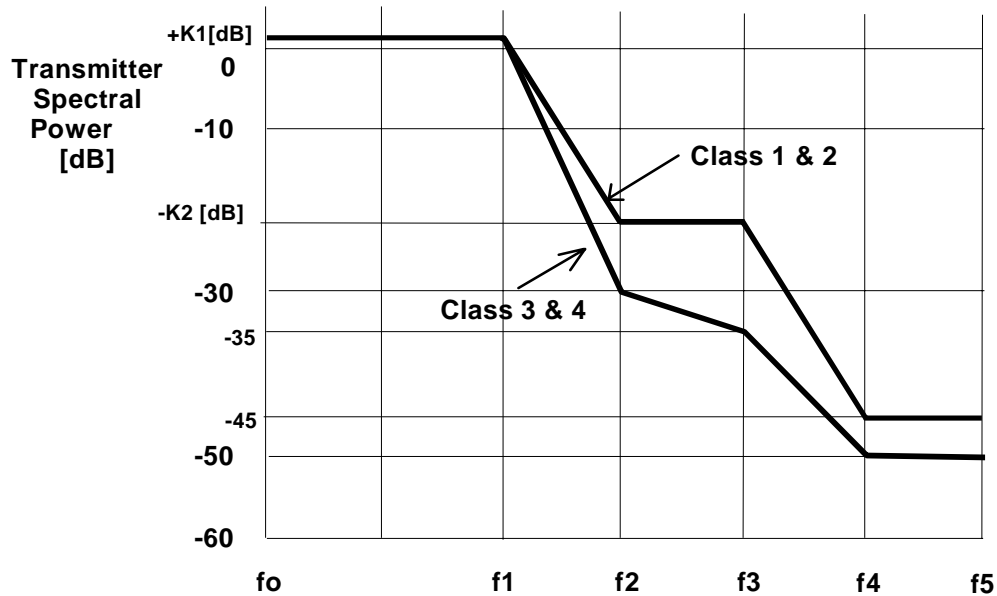

NOTE: Frequency from actual transmitter centre frequency [MHz]

Figure 2: Limits of spectral power density

Due to limitations of some spectrum analysers, difficulties may be experienced when testing high capacity/wideband systems. In this event, the following options are to be considered: measurement using high performance spectrum analyser, use of notch filters and two-step measurement technique. Where difficulties are experienced, the plots of one test may be produced as evidence to conformance to the spectrum mask.

Reference frequencies f_1 to f_5 and relative attenuation K_1 [dB] and K_2 [dB] are reported in table 3 for the bit rate and channel spacing foreseen:

Table 3: Spectrum mask frequency limits

Spectrum efficiency class	Bit-rate [Mbit/s]	Channel spacing [MHz]	K1 [dB]	K2 [dB]	f1 [MHz]	f2 [MHz]	f3 [MHz]	f4 [MHz]	f5 [MHz]
1	2 or 2 x 2	7	0	-25	3,3	6,1	6,8	12,8	17,5
	8	14	0	-25	6	11,6	13	22	35
	2 x 8	28	0	-25	12	24,2	26	45	70
	34	56	0	-25	24	50	60	80	140
2	2	3,5	+1	-23	1,3	2	2,3	4,3	8,75
	2 x 2	3,5	+1	-23	1,4	2,8	3,5	7	8,75
	8	7	+1	-23	2,8	5,6	7	14	17,5
	2 x 8	14	+1	-23	5,6	11,2	14	28	35
	34	28	+1	-23	11	19	25	45	70
	51	56	+1	-23	18	32	40	70	140
3	51	28	+1	n.a.	10,5	18	28	35,5	70
4	8	3,5	+1	n.a.	1,4	2,8	3,5	7	8,75
	2 x 8	7	+1	n.a.	2,8	5,6	7	14	17,5
	34	14	+1	n.a.	5,6	11,2	14	28	35
	51	14	+1	n.a.	7	9,5	14	28	35
	140 or 155	56	+1	n.a.	22,5	33	65	80	140

5.3.6 Spectral lines at the symbol rate

The power level (reference point B') of spectral lines at a distance from the channel centre frequency equal to the symbol rate shall be more than 23 dB below the average power level of the carrier for efficiency classes 1 and 2 and 37 dB for efficiency classes 3 and 4.

5.3.7 Spurious emissions

It is necessary to define spurious emissions from transmitters for two reasons:

- to limit interference into other systems operating wholly externally to the system under consideration (external emissions), which limits are referred by CEPT/ERC Recommendation 74-01 [2] based on ITU-R Recommendations SM.329-8 [34], and ITU-R Recommendation F1191 [19].
- to limit local interference within the system where transmitters and receivers are directly connected via the filter and branching systems (internal emissions).

This leads to two sets of spurious emission limits where the specific limits given for "internal" interference are required to be no greater than the "external" level limits at reference point B' for indoor systems and C' for outdoor systems (where a common Tx/Rx duplexer is used).

5.3.7.1 Spurious emissions - external

According to ITU-R Recommendation F.1191 [19] and CEPT/ERC Recommendation 74-01 [2], the external spurious emissions are defined as emissions at frequencies which are outside the nominal carrier frequency $\pm 250\%$ of the relevant channel separation.

The limits of these emissions shall conform to CEPT/ERC Recommendation 74-01 [2].

5.3.7.2 Spurious emissions - internal

Given that there is no requirement to multiplex equipment of different supplier on the same antenna, there is no requirement for internal spurious emissions.

5.3.8 Radio frequency tolerance

Maximum radio frequency tolerance shall not exceed ± 15 ppm. This limit includes both short-term factors (environmental effects) and long-term ageing effects.

In the type test the manufacturer shall state the guaranteed short-term part and the expected ageing part.

5.4 Receiver characteristics

5.4.1 Input level range

The input level range for a BER $< 10^{-3}$ shall extend for a minimum of 50 dB above the threshold limit specified for BER = 10^{-3} in clause 5.5.1 referenced to point C.

The input level range for a BER $< 10^{-8}$ shall extend for a minimum of 41 dB above the threshold limit specified for BER = 10^{-8} in clause 5.5.1 referenced to point C.

However an upper limit above -20 dBm is not required for BER = 10^{-3} and -24 dBm for BER = 10^{-8} .

5.4.2 Receiver local oscillator frequency arrangements

There shall be no requirement on receiver LO frequency arrangement.

5.4.3 Spurious emissions

At reference point C the limit values of CEPT/ERC Recommendation 74-01 [2] shall apply.

5.4.3.1 Spurious emissions - external

The limits of these emissions shall conform to CEPT/ERC Recommendation 74-01 [2].

5.4.3.2 Spurious emissions - internal

Given that there is no requirement to multiplex equipment of different suppliers on the same antenna, there is no requirement for internal spurious emissions.

5.5 System performance without diversity

All parameters are referred to reference point C of figure 1. Losses in RF couplers used for protected systems are not taken into account in the limits specified below.

All measurements shall be carried out with the test signals defined in clause 5.3.

5.5.1 BER as a function of Receiver input Signal Level (RSL)

Receiver BER thresholds (dBm) referred to reference point C of the system block diagram (see figure 1) for a BER of 10^{-3} , 10^{-6} and 10^{-8} shall be equal to or lower than those stated in table 4.

Table 4: BER performance thresholds

Spectrum efficiency class ↓	Bit-rate [Mbit/s] ↓	Channel spacing [MHz] ↓	RSL @ 10 ⁻³	RSL @ 10 ⁻⁶	RSL @ 10 ⁻⁸
			[dBm]	[dBm]	[dBm]
1	2	7	-84	-80,5	-78
	2 × 2	7	-84	-80,5	-78
	8	14	-81	-77,5	-75
	2 × 8	28	-78	-74,5	-72
	34	56	-75	-71,5	-69
2	2	3,5	-84	-80,5	-78
	2 × 2	3,5	-81	-77,5	-75
	8	7	-78	-74,5	-72
	2 × 8	14	-75	-71,5	-69
	34	28	-72	-68,5	-66
	51	56	-71	-67,5	-65
3	51	28	-69	-65,5	-63
4	8	3,5	-74	-70,5	-68
	2 × 8	7	-71	-67,5	-65
	34	14	-68	-64,5	-62
	51	14	-67	-63,5	-61
	140 or 155	56	-64	-60,5	-58

5.5.2 Residual BER

The RBER level under simulated operating conditions without interference shall be guaranteed with a signal level at reference point C which is between 10 dB and 35 dB above the level which gives BER = 10⁻⁶ (as specified in clause 5.5.1). However an upper limit above -32 dBm is not required.

To guarantee a higher degree of service, see clause A.2, the network operator may require equipment to meet a RBER limit with the first adjacent channel interferer. For this equipment the RBER level under simulated operating conditions with first adjacent channel interference shall be guaranteed with a signal level at reference point C, which is between 15 dB and 35 dB above the level which gives a BER = 10⁻⁶ (as specified in clause 5.5.1) and with the adjacent channel interference set to a level which reflects the full output power tolerance of the transmitter i.e. 6 dB.

The RBER shall be:

- for systems capacity less than 34 Mbit/s: RBER < 10⁻¹⁰;
- for systems capacity at 34/51 Mbit/s: RBER < 10⁻¹¹;
- for systems capacity at 140/155 Mbit/s: RBER < 10⁻¹².

This requirement is intended for the payload bit rates defined in clause 5.1.

EN 301 126-1 [3] recognizes that this requirement is subject to a supplier declaration only. However, in clause A.2 some background information relating to the actual test methods and test confidence is given.

5.5.3 Interference sensitivity

All receive signal levels and Carrier to Interference ratio (C/I) measurements are referred to reference point C of the RF system block diagram (see figure 1).

5.5.3.1 Co-channel interference sensitivity

The limits of Co-channel Interference (C/I) shall be as in table 5, giving maximum C/I values for 1 dB and 3 dB degradation of the 10^{-6} BER limits specified in clause 5.5.1.

The indicative behaviour for these and other values of degradation may be found in figures A.3.1 and A.3.2.

Table 5: Co-channel interference sensitivity

Co-channel interference		RSL @ BER →		RSL @ 10^{-6}	
		degradation →		1 dB	3 dB
Spectrum efficiency class ↓	Bit rate [Mbit/s] ↓	Channel spacing [MHz] ↓			
1	2	7	23	19	
	2 × 2	7	23	19	
	8	14	23	19	
	2 × 8	28	23	19	
	34	56	23	19	
2	2	3,5	23	19	
	2 × 2	3,5	23	19	
	8	7	23	19	
	2 × 8	14	23	19	
	34	28	23	19	
	51	56	23	19	
3	51	28	30	26	
4	8	3,5	30	26	
	2 × 8	7	30	26	
	34	14	30	26	
	51	14	30	26	
	140 or 155	56	30	26	

5.5.3.2 Adjacent channel interference

The limits of adjacent channel interference shall be as given in table 6 for like modulated signals spaced of 1 channel spacing, giving maximum C/I values for 1 dB and 3 dB degradation of the 10^{-6} BER limits specified in clause 5.5.1.

The Indicative behaviour for these and other values of degradation may be found in figures A.3.1 and A.3.2.

Table 6: First adjacent channel interference sensitivity

First adjacent channel interference	RSL @ BER →		RSL @ 10^{-6}	
	degradation →		1 dB	3 dB
Spectrum efficiency class ↓	Bit rate [Mbit/s] ↓	Channel spacing [MHz] ↓		
1	2	7	0	-4
	2 x 2	7	0	-4
	8	14	0	-4
	2 x 8	28	0	-4
	34	56	0	-4
2	2	3,5	-3	-7
	2 x 2	3,5	0	-4
	8	7	0	-4
	2 x 8	14	0	-4
	34	28	0	-4
3	51	56	0	-4
	51	28	-1	-5
4	8	3,5	-1	-5
	2 x 8	7	-1	-5
	34	14	-1	-5
	51	14	-1	-5
	140 or 155	56	-1	-5

5.5.3.3 Continuous Wave (CW) spurious interference

For a receiver operating at the 10^{-6} BER threshold given in table 4, the introduction of a CW interferer at a certain level specified below, with respect to the wanted signal and at any frequency in the range 30 MHz to 80 GHz, excluding frequencies either side of the wanted centre frequency of the RF channel by up to 250 % of the channel spacing, shall not result in a BER greater than 10^{-5} .

The level of the CW interferer shall be:

- for a channel spacing lower than or equal to 14 MHz:
 - +20 dB at any frequency either side of the wanted centre frequency of the RF channel from 250 % up to 500 % of the channel spacing;
 - +30 dB outside 500 % of the channel spacing;
- for a channel spacing greater than 14 MHz:
 - +30 dB

NOTE: When waveguide is used between reference points A and C, which length is higher than twice the free space wavelength of the cut-off frequency (F_c), the lower limit of measurement will be increased to $0,7 F_c$ and to $0,9 F_c$ when the length is higher than 4 times the same wavelength.

This test is designed to identify specific frequencies at which the receiver may have a spurious response, e.g. image frequency, harmonics of the receive filter, etc. The actual test range should be adjusted accordingly. The test is not intended to imply a relaxed specification at all out of band frequencies elsewhere specified in the present document.

5.5.3.4 Front-end non-linearity requirements (two-tone CW spurious interference)

For a receiver operating at the RSL specified in clause 5.5.1 for 10^{-6} BER threshold, the introduction of two equal CW interferers each with a level of +19 dB, with respect to the wanted signal and located at the second and fourth adjacent channel in the receive half-band, shall not result in a BER greater than 10^{-5} .

5.5.4 Distortion sensitivity

Outage from multi-path phenomena is not considered relevant for the systems subject to the present document.

5.6 System characteristics with diversity

Space diversity receive is not relevant for the systems subject to the present document.

Annex A (informative): Additional information

A.1 Radio frequency channel arrangement

The relevant radio frequency channel arrangement for FDD systems is provided by CEPT/ERC Recommendation 12-11 E (Luxembourg 1990) [1] however, for the reader's convenience, figure A.1 gives its general overview:

The 7 MHz and 3,5 MHz channels are shown only for information purposes until CEPT agreement has been reached.

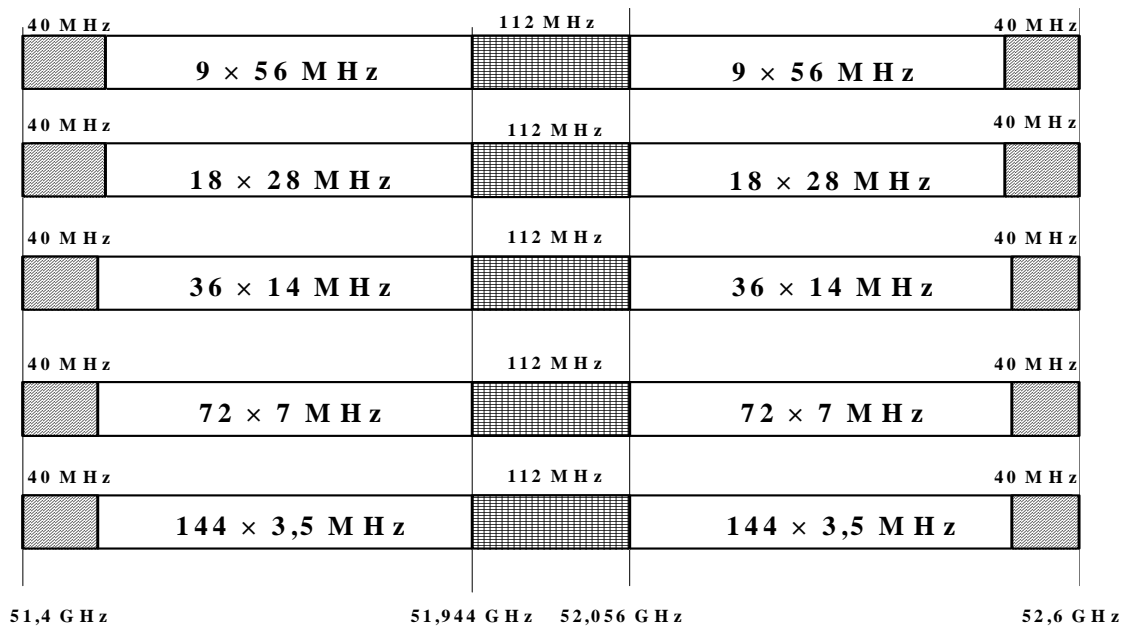

Figure A.1: Radio frequency channel arrangement

A.2 RBER

In particular applications, where there is a high density of radio links in a specific area, e.g. nodal site, closely located radios may use adjacent channels. Therefore to guarantee the grade of service the equipment will need to meet RBER criteria in the presence of an adjacent channel interferer.

The RBER is standardized in order to match the ESR (or the BBER) performance required by ITU-R transmission performance recommendations.

To have sufficient confidence in the measurement, where the BER is relatively low compared to the actual payload, the test time is very long. The actual background to this measurement and the BER figures are detailed in TR 101 036-1 [13]

When error correction is a fitted feature it may be possible to reduce the measurement time by estimating the RBER using the relevant formula declared by the supplier.

Another option is to ensure that no errors occur during the minimum recording time shown in table A.1.

Table A.1: Zero errors recording times

Bit-rate under test [Mbit/s]	Minimum recording time [minutes]	errors
2	82	0
8	21	0
34	50	0
51	34	0
140/155	108	0

A.3 Co-channel and adjacent channel interference

The performances for co-channel and adjacent channel spaced by one channel spacing C/I are reported in clauses 5.5.3.1 and 5.5.3.2 for 1 dB and 3 dB degradation only. Figures A.3.1 and A.3.2 give the indicative behaviour for other values of degradation. The values represented should not be used for frequency co-ordination purposes

**Receiver Input Level at Reference Point C
relative to BER 10^{-6} threshold**

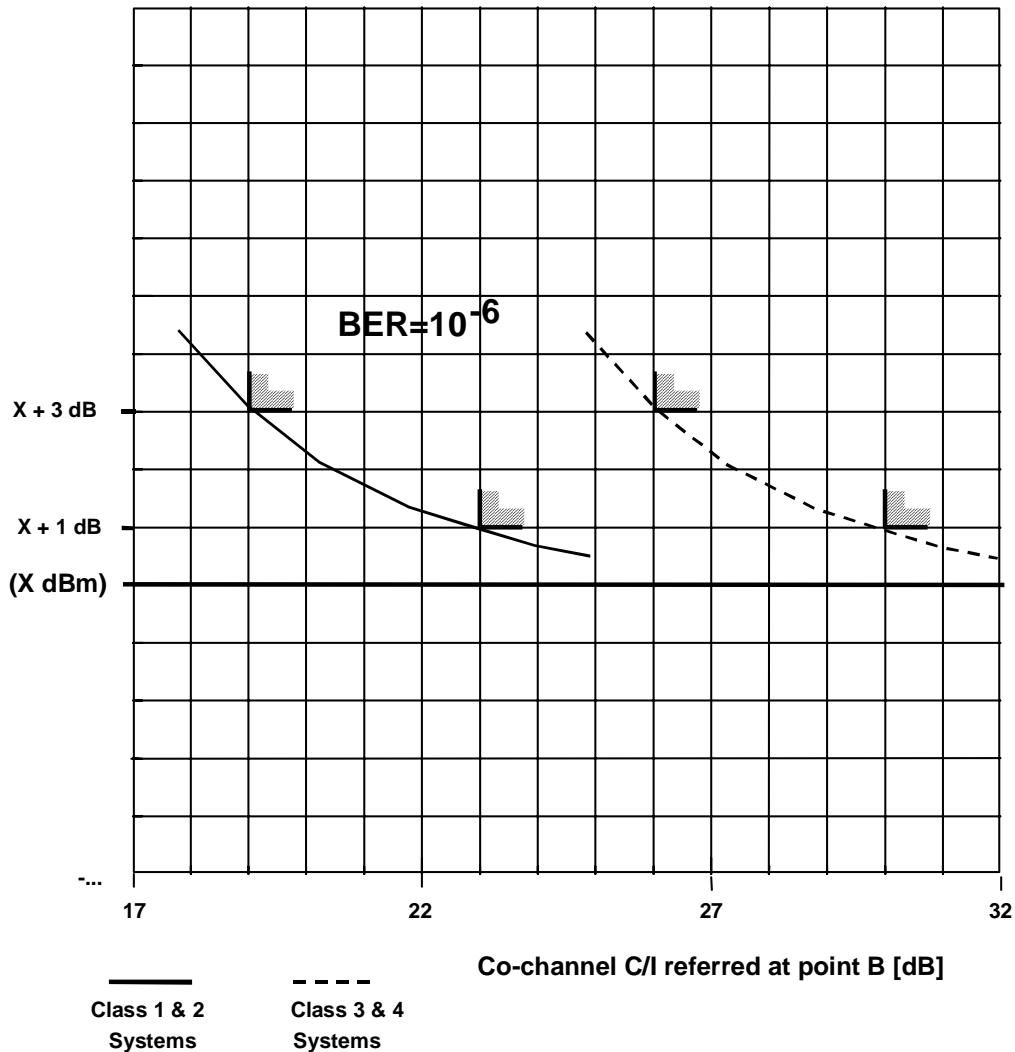

NOTE: $X \text{ dBm} = 10^{-6}$ BER threshold provided by clause 5.5.1.

Figure A.3.1: Co-channel interference threshold degradation

Receiver Input Level at Reference Point C
relative to BER 10^{-6} threshold

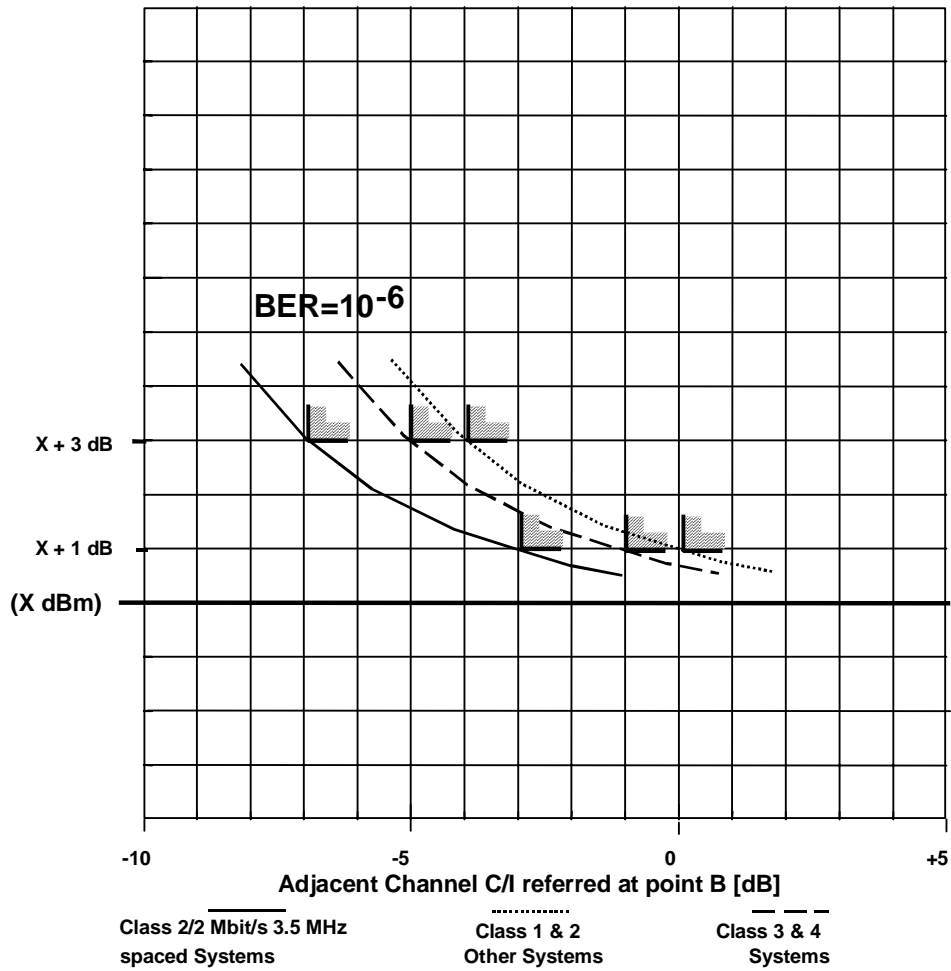

NOTE: X dBm = 10^{-6} BER threshold provided by clause 5.5.1.

Figure A.3.2: First adjacent channel interference threshold degradation

Annex B:
Void

Annex C (normative): System type codes for regulatory procedures

System types reported in the present document shall be identified with the codes reported in table C1.

Table C.1: System type codes for radio equipment reported in the present document, relevant to regulatory procedures for national licensing

Spectrum efficiency class ↓	Channel spacing [MHz] ↓	Bit-rate [Mbit/s] ↓	System type codes ↓
1	7	2	01
	7	2 x 2	02
	14	8	03
	28	2 x 8	04
	56	34	05
2	3,5	2	06
	3,5	2 x 2	07
	7	8	08
	14	2 x 8	09
	28	34	10
56	51	11	
3	28	51	12
4	3,5	8	13
	7	2 x 8	14
	14	34	15
	14	51	16
	56	140 or 155	17

History

Document history		
V1.1.1	April 2000	Public Enquiry PE 20000818: 2000-04-19 to 2000-08-18
V1.1.2	March 2001	Vote V 20010504: 2001-03-05 to 2001-05-04
V1.1.2	May 2001	Publication