

**Fixed Radio Systems;
Point-to-Point Packet Data Equipment;
Parameters for radio systems with packet data interfaces
for transmission of digital signals operating in the frequency
range 7, 8, 13, 15, 18, 23, 26, 28, 32, 38, 52 to 55 GHz**



Reference

REN/TM-04113

Keywords

digital, DRRS, point-to-point, radio, transmission

ETSI

650 Route des Lucioles
F-06921 Sophia Antipolis Cedex - FRANCE

Tel.: +33 4 92 94 42 00 Fax: +33 4 93 65 47 16

Siret N° 348 623 562 00017 - NAF 742 C
Association à but non lucratif enregistrée à la
Sous-Préfecture de Grasse (06) N° 7803/88

Important notice

Individual copies of the present document can be downloaded from:

<http://www.etsi.org>

The present document may be made available in more than one electronic version or in print. In any case of existing or perceived difference in contents between such versions, the reference version is the Portable Document Format (PDF). In case of dispute, the reference shall be the printing on ETSI printers of the PDF version kept on a specific network drive within ETSI Secretariat.

Users of the present document should be aware that the document may be subject to revision or change of status. Information on the current status of this and other ETSI documents is available at

<http://portal.etsi.org/tb/status/status.asp>

If you find errors in the present document, send your comment to:

editor@etsi.fr

Copyright Notification

No part may be reproduced except as authorized by written permission.
The copyright and the foregoing restriction extend to reproduction in all media.

© European Telecommunications Standards Institute 2001.
All rights reserved.

Contents

Intellectual Property Rights	4
Foreword.....	4
1 Scope	5
2 References	5
3 Definitions, symbols and abbreviations	7
3.1 Definitions	7
3.2 Symbols.....	7
3.3 Abbreviations	7
4 General characteristics	7
4.1 Channel arrangements	7
4.2 Channel spacing	7
4.3 Baseband interface parameters	7
4.3.1 Ethernet data interface	7
4.3.2 Plesiochronous interfaces	8
4.3.3 ISDN interface (primary rate).....	8
4.3.4 SDH baseband interface.....	8
4.4 Performance and availability requirements	8
4.5 System block diagram	8
4.6 Other general characteristics	8
5 System parameters.....	9
5.1 Selection of specification	9
5.2 Translation of requirements.....	11
Annex A (informative): FER/BER equivalence and FER measurement.....	12
A.1 FER/BER equivalence.....	12
A.2 FER equipment settings and measurement techniques (example)	12
Annex B (informative): Bibliography.....	13
History	14

Intellectual Property Rights

IPRs essential or potentially essential to the present document may have been declared to ETSI. The information pertaining to these essential IPRs, if any, is publicly available for **ETSI members and non-members**, and can be found in ETSI SR 000 314: "*Intellectual Property Rights (IPRs); Essential, or potentially Essential, IPRs notified to ETSI in respect of ETSI standards*", which is available from the ETSI Secretariat. Latest updates are available on the ETSI Web server (<http://www.etsi.org/legal/home.htm>).

Pursuant to the ETSI IPR Policy, no investigation, including IPR searches, has been carried out by ETSI. No guarantee can be given as to the existence of other IPRs not referenced in ETSI SR 000 314 (or the updates on the ETSI Web server) which are, or may be, or may become, essential to the present document.

Foreword

This European Standard (Telecommunications series) has been produced by ETSI Technical Committee Transmission and Multiplexing (TM), and is now submitted for the ETSI standards One-step Approval Procedure.

The present document has already been published as an ETSI Technical Specification, under TS 101 785.

This V1.2.1 contains full formal revision, in term of definitions of spectral efficiency, now referenced to other existing ENs for conventional PDH/SDH application in the same frequency bands.

The former title of the present document v1.1.1 was "Fixed Radio Systems; Point-to-point equipment; Parameters for packet data radio systems for transmission of digital signals operating in the frequency range 23, 26, 28 or 38 GHz".

Proposed national transposition dates	
Date of latest announcement of this EN (doa):	3 months after ETSI publication
Date of latest publication of new National Standard or endorsement of this EN (dop/e):	6 months after doa
Date of withdrawal of any conflicting National Standard (dow):	6 months after doa

1 Scope

The present document specifies the minimum performance parameters for terrestrial fixed service radio communications equipment operating at 7, 8, 13, 15, 18, 23, 26, 28, 32, 38, 52 to 55 GHz provided with a combination Packet data interfaces or of Packet Data interfaces and PDH/SDH interfaces. Such digital systems are intended for use for point-to-point connections in local and regional networks.

For regulatory purpose, reference shall be made to existing PDH/SDH standards to be used to assess the efficient use of radio spectrum.

2 References

The following documents contain provisions which, through reference in this text, constitute provisions of the present document.

- References are either specific (identified by date of publication, edition number, version number, etc.) or non-specific.
- For a specific reference, subsequent revisions do not apply.
- For a non-specific reference, the latest version applies.

NOTE: In the EN version of the present document, the following provisions will be added:
"In the case of non-specific references, the time frame of application and new certification procedures for new releases of these normative references after the date of the first public enquiry of the present document or the first certification of the equipment shall be agreed between the supplier and the regulatory authority. These new certification procedures will cover in any case only the parameters subject to changes from the on going release during the previous certification."

- [1] ITU-R Recommendation F.1102: "Characteristics of radio-relay systems operating in frequency bands above about 17 GHz".
- [2] ITU-R Recommendation P.530-8: "Propagation data and prediction methods required for the design of terrestrial line-of-sight systems".
- [3] ETSI TR 101 035 (V1.1.3): "Transmission and Multiplexing (TM); Synchronous Digital Hierarchy (SDH) aspects regarding Digital Radio Relay Systems (DRRS)".
- [4] ISO/IEC 8802-3 (1996): "Information technology - Telecommunications and information exchange between systems - Local and metropolitan area networks - Specific requirements - Part 3: Carrier sense multiple access with collision detection (CSMA/CD) access method and physical layer specifications".
- [5] IEEE 802.3 (1998): "Information technology - Telecommunications and information exchange between systems - Local and metropolitan area networks - Specific requirements - Part 3: Carrier sense multiple access with collision detection (CSMA/CD) access method and physical layer specifications".
- [6] IEEE 802.1Q (1998): "Local and Metropolitan Area Networks: Virtual Bridged Local Area Networks".
- [7] ETSI EN 300 197 (V1.3.1): "Fixed Radio Systems; Point-to-point equipment; Parameters for radio systems for the transmission of digital signals operating at 38 GHz".
- [8] ETSI EN 300 198 (V1.3.1): "Fixed Radio Systems; Point-to-point equipment; Parameters for radio systems for the transmission of digital signals operating at 23 GHz".
- [9] ETSI EN 300 407 (V1.2.1): "Fixed Radio Systems; Point-to-point equipment; Parameters for digital radio systems for the transmission of digital signals operating at 55 GHz".

- [10] ETSI EN 300 234 (V1.2.1): "Transmission and Multiplexing (TM); Digital Radio Relay Systems (DRRS); High capacity DRRS carrying 1 x STM-1 signals and operating in frequency bands with about 30 MHz channel spacing and alternated arrangements".
- [11] ETSI EN 300 430 (V1.2.1): "Fixed Radio Systems; Point-to-point equipment; Parameters for radio systems for the transmission of STM-1 digital signals operating in the 18 GHz frequency band with channel spacing of 55 MHz and 27,5 MHz".
- [12] ETSI EN 300 431 (V1.2.1): "Fixed Radio Systems; Point-to-point equipment; Parameters for radio system for the transmission of digital signals operating in the frequency range 24,50 GHz to 29,50 GHz".
- [13] ETSI EN 300 639 (V1.2.1): "Fixed Radio Systems; Point-to-point equipment; Sub-STM-1 digital radio systems operating in the 13 GHz, 15 GHz and 18 GHz frequency bands with about 28 MHz co-polar and 14 MHz cross-polar channel spacing".
- [14] ETSI EN 300 786 (V1.2.1): "Fixed Radio Systems; Point-to-point equipment; Sub-STM-1 digital radio systems operating in the 13 GHz, 15 GHz and 18 GHz frequency bands with about 14 MHz co-polar channel spacing".
- [15] ETSI EN 301 128 (V1.1.2): "Fixed Radio Systems; Point-to-point equipment; Plesiochronous Digital Hierarchy (PDH); Low and medium capacity digital radio systems operating in the 13 GHz, 15 GHz and 18 GHz frequency bands".
- [16] ETSI EN 301 216 (V1.1.1): "Fixed Radio Systems; Point-to-point equipment; Plesiochronous Digital Hierarchy (PDH); Low and medium capacity and STM-0 digital radio system operating in the frequency bands in the range 3 GHz to 11 GHz".
- [17] ETSI EN 301 751: "Fixed Radio Systems; Point-to-Point equipments and antennas; Generic harmonized standard for Point-to-Point digital fixed radio systems and antennas covering the essential requirements under article 3.2 of the 1999/5/EC Directive".
- [18] ETSI EN 301 786 (V1.2.1): "Fixed Radio Systems; Point-to-point equipment; Parameters for digital radio systems for the transmission of digital signals operating at 52 GHz".
- [19] ITU-T Recommendation G.703: "Physical/electrical characteristics of hierarchical digital interfaces".
- [20] ITU-T Recommendation G.704: "Synchronous frame structures used at 1 544, 6 312, 2 048, 8 448 and 44 736 kbit/s hierarchical levels".
- [21] ITU-T Recommendation I.412: "ISDN user-network interfaces - Interface structures and access capabilities".
- [22] ETSI ETS 300 233: "Integrated Services Digital Network (ISDN); Access digital section for ISDN primary rate".
- [23] ITU-T Recommendation G.707: "Network node interface for the synchronous digital hierarchy (SDH)".
- [24] ITU-T Recommendation G.783: "Characteristics of synchronous digital hierarchy (SDH) equipment functional blocks".
- [25] ITU-T Recommendation G.784: "Synchronous digital hierarchy (SDH) management".
- [26] ITU-T Recommendation G.957: "Optical interfaces for equipments and systems relating to the synchronous digital hierarchy".
- [27] ITU-R Recommendation F.750: "Architectures and functional aspects of radio-relay systems for synchronous digital hierarchy (SDH)-based networks".
- [28] Directive 1999/5/EC of the European Parliament and of the Council of 9 March 1999 on radio equipment and telecommunications terminal equipment and the mutual recognition of their conformity (R&TTE Directive) .

3 Definitions, symbols and abbreviations

3.1 Definitions

For the purposes of the present document, the following terms and definitions apply:

Radio Interface Capacity (RIC): maximum user capacity, defined at reference point X/X', that can be transmitted over the radio interface, defined at reference point C'

Network Interface Capacity (NIC): sum of the maximum bit rates of the implemented base band interfaces at reference point X/X'

3.2 Symbols

For the purposes of the present document, the following symbols apply:

GHz	GigaHertz
Mbit/s	Mega-bits per second
MHz	MegaHertz

3.3 Abbreviations

For the purposes of the present document, the following abbreviations apply:

BER	Bit Error Ratio
DRRS	Digital Radio Relay Systems
FER	Frame Error Ratio
RIC	Radio Interface Capacity
NIC	Network Interface Capacity

4 General characteristics

4.1 Channel arrangements

The equipments shall operate on channels in accordance with the referenced radio standard selected from clause 5.1.

4.2 Channel spacing

The channel spacings and the equipment classes for the referenced standards and the required Radio Interface Capacities are defined in clause 5.1.

4.3 Baseband interface parameters

All of the following specified data interface parameters refer to point X and X' of figure 1.

4.3.1 Ethernet data interface

10 Mbit/s, 100 Mbit/s and 1 000 Mbit/s interfaces shall comply with the OSI physical layer requirements of ISO/IEC 8802-3 [4] and IEEE 802.3 [5] respectively. 10 Mbit/s, 100 Mbit/s and 1 000 Mbit/s interfaces shall comply with the maximum packet sizes defined in IEEE 802.1Q [6].

4.3.2 Plesiochronous interfaces

Plesiochronous interfaces at 2 Mbit/s, 8 Mbit/s and 34 Mbit/s shall comply with ITU-T Recommendation G.703 [19]. Parameters for service channels and wayside traffic channels are outside the scope of the present document.

4.3.3 ISDN interface (primary rate)

The transmission of 2 Mbit/s signals using the structure and functions of ISDN primary multiplex signals is to be in accordance with ITU-T Recommendations G.703 [19], G.704 [20], I.412 [21] and ETS 300 233 [22].

4.3.4 SDH baseband interface

SDH baseband interfaces shall comply with ITU-T Recommendations G.703 [19], G.707 [23], G.783 [24], G.784 [25] and G.957 [26] and ITU-R Recommendation F.750 [27].

The use of reserved bytes contained in the SOH, and their termination shall be in accordance with ITU-R Recommendation F.750 [27]. Further details on the possible use of the SOH bytes reserved for future international standardization are given in TR 101 035 [3].

4.4 Performance and availability requirements

Digital equipment shall be designed in order to meet network performance requirements in the standard selected according to clause 5.1 and those defined in ISO/IEC 8802-3 [4] for 10 Mbit/s Medium Attachment Units and IEEE 802.3 [5] for 100 Mbit/s and 1 000 Mbit/s Physical Layer Devices. The implication of the link design on the performance is recognized and the general design criteria reported in ITU-R Recommendations P.530-8 [2] and F.1102 [1] shall be applied. Performance requirements for public networks are under study by the ITU-T.

All performance measurements shall be done with 64 octet frames.

4.5 System block diagram

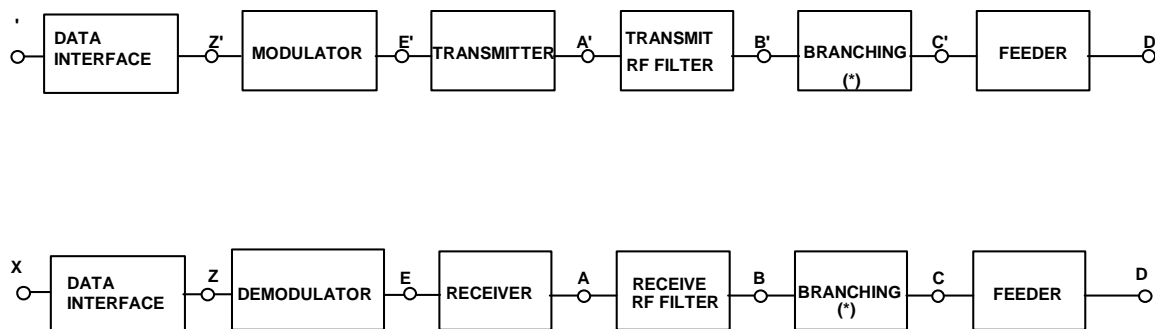

NOTE 1: For the purpose of defining the measurement points, the branching network does not include a hybrid.

NOTE 2: The points shown above are reference points only; points C and C', D and D' in general coincide.

NOTE 3: Points B and C, B' and C' may coincide when simple duplexer is used.

Figure 1: System block diagram

4.6 Other general characteristics

All general characteristics of the equipment, apart from those detailed above, shall be in accordance with the referenced radio standard selected from clause 5.1.

5 System parameters

5.1 Selection of specification

All radio requirements shall be taken from an appropriate PDH or SDH specification. This clause describes how to select an appropriate PDH/SDH specification to be applied to a radio system with packet data interfaces. System type codes shall be taken from the selected PDH/SDH specification.

The manufacturer shall declare the Radio Interface Capacity (RIC). The Radio Interface Capacity (RIC) must exceed the minimum RIC given in table 2 to allow application of a specific PDH/SDH standard.

The Network Interface Capacity (NIC) must be equal to or exceed the Radio Interface Capacity (RIC) to allow application of a specific PDH/SDH standard from table 2.

For declaration of conformity according to annex III of the R&TTE directive [28], the version of the PDH/SDH standard shall be the one referred to in EN 301 751 [17]. The essential requirements are those listed in EN 301 751 [17] and repeated for convenience in table 1.

Table 1: List of essential requirements

Clause in [17]	Requirements
4.5.1	Frequency error/stability
4.5.2	Transmitter power
4.5.3.1	Adjacent channel power - Spectrum mask and spectral lines at symbol rate
4.5.3.2	Adjacent channel power - Remote Transmit Power Control (RTPC)
4.5.4	Spurious emissions
4.5.5.1	Transient behaviour of the transmitter - Automatic Transmit Power Control (ATPC)
4.5.5.2	Transient behaviour of the transmitter - Remote Frequency Control (RFC)
4.7.1	BER as a function of receiver input signal level
4.7.2	Co-channel interference sensitivity
4.7.3	Adjacent channel interference sensitivity
4.7.4	Blocking or desensitization inc. duplex (CW Spurious Interference)
4.7.5	Spurious emissions

Table 2: Applicable PDH/SDH specifications for packet data systems

Frequency band [GHz]	Channel spacing [MHz]	Minimum RIC [Mbit/s]	Applicable PDH/SDH standard	Equipment class
7, 8	7	8	EN 301 216 [16]	1
7, 8	7	16	EN 301 216 [16]	2
7, 8	14	16	EN 301 216 [16]	1
7, 8	14	34	EN 301 216 [16]	2
7, 8	14	50	EN 301 216 [16]	3
7, 8	14	68	EN 301 216 [16]	3
7, 8	About 30	34	EN 301 216 [16]	1
7, 8	About 30	50	EN 301 216 [16]	2
7, 8	About 30	68	EN 301 216 [16]	3
7, 8, 13, 15	About 30	150	EN 300 234 [10]	5
13, 15	1,75	2	EN 301 128 [15]	1
13, 15	1,75	4	EN 301 128 [15]	2
13, 15	3,5	4	EN 301 128 [15]	1
13, 15	3,5	8	EN 301 128 [15]	2
13, 15	7	8	EN 301 128 [15]	1
13, 15	7	16	EN 301 128 [15]	2
13, 15, 18	13.75/14	16	EN 301 128 [15]	1
13, 15, 18	13.75/14	34	EN 301 128 [15]	2
13, 15, 18	13.75/14	50	EN 300 786 [14]	-
13, 15, 18	27.5/28	34	EN 301 128 [15]	1
13, 15, 18	27.5/28	50	EN 300 639 [13]	-
13, 15, 18	27.5/28	68	EN 301 128 [15]	2
18	27.5	150	EN 300 430 [11]	5a,b

Frequency band [GHz]	Channel spacing [MHz]	Minimum RIC [Mbit/s]	Applicable PDH/SDH standard	Equipment class
18	55	150	EN 300 430 [11]	4
23	3,5	4	EN 300 198 [8]	2
23	3,5	8	EN 300 198 [8]	4
23	7	8	EN 300 198 [8]	2
23	7	16	EN 300 198 [8]	4
23	14	16	EN 300 198 [8]	2
23	14	34	EN 300 198 [8]	4
23	14	50	EN 300 198 [8]	4
23	28	34	EN 300 198 [8]	2
23	28	50	EN 300 198 [8]	4
23	28	150	EN 300 198 [8]	5a,b
23	56	150	EN 300 198 [8]	4
26	3,5	4	EN 300 431 [12]	2
26	3,5	8	EN 300 431 [12]	4
26	7	8	EN 300 431 [12]	2
26	7	16	EN 300 431 [12]	4
26	14	16	EN 300 431 [12]	2
26	14	34	EN 300 431 [12]	4
26	14	50	EN 300 431 [12]	4
26	28	34	EN 300 431 [12]	2
26	28	50	EN 300 431 [12]	4
26	28	150	EN 300 431 [12]	5a,b
26	56	150	EN 300 431 [12]	4
32, 38	3,5	4	EN 300 197 [7]	2
32, 38	3,5	8	EN 300 197 [7]	4
32, 38	7	8	EN 300 197 [7]	2
32, 38	7	16	EN 300 197 [7]	4
32, 38	14	16	EN 300 197 [7]	2
32, 38	14	34	EN 300 197 [7]	4
32, 38	14	50	EN 300 197 [7]	4
32, 38	28	34	EN 300 197 [7]	2
32, 38	28	50	EN 300 197 [7]	4
32, 38	28	150	EN 300 197 [7]	5a,b
32, 38	56	150	EN 300 197 [7]	4
52	3,5	4	EN 301 786 [18]	2
52	3,5	8	EN 301 786 [18]	4
52	7	8	EN 301 786 [18]	2
52	7	16	EN 301 786 [18]	4
52	14	16	EN 301 786 [18]	2
52	14	34	EN 301 786 [18]	4
52	14	50	EN 301 786 [18]	4
52	28	34	EN 301 786 [18]	2
52	28	50	EN 301 786 [18]	4
52	28	150	EN 301 786 [18]	5a,b
52	56	150	EN 301 786 [18]	4
55	3,5	4	EN 300 407 [9]	2
55	3,5	8	EN 300 407 [9]	4
55	7	8	EN 300 407 [9]	2
55	7	16	EN 300 407 [9]	4
55	14	16	EN 300 407 [9]	2
55	14	34	EN 300 407 [9]	4
55	14	50	EN 300 407 [9]	4
55	28	34	EN 300 407 [9]	2
55	28	50	EN 300 407 [9]	4
55	28	150	EN 300 407 [9]	5a,b
55	56	150	EN 300 407 [9]	4

5.2 Translation of requirements

This clause describes how to translate the requirements from the PDH/SDH specification to verify compliance of the radio system with packet data interfaces.

The manufacturer shall describe how to load the system with the Radio Interface Capacity (RIC), possibly using multiple interfaces. The error rates specified in the PDH/SDH specification shall be met on all traffic loading the system. The traffic may contain both PDH, SDH and packet data. For Ethernet interfaces, the BER requirements in the PDH/SDH standard shall be converted to FER requirements using table 3 (based on 64 octet frames). For this type of equipment, the BER= 10^{-3} requirement is not considered to be essential and is therefore omitted from table 3.

Table 3: Conversion between Bit Error Rate (BER) and Frame Error Rate (FER)

BER	FER
10^{-6}	5×10^{-4}
10^{-8}	5×10^{-6}
10^{-10}	5×10^{-8}
10^{-12}	5×10^{-10}

Annex A (informative): FER/BER equivalence and FER measurement

A.1 FER/BER equivalence

FER and BER can be translated as described herein. Ethernet frames can range from 64 octets up to 1 522 octets. In the example below 64 octet frames have been used.

An Ethernet frame is considered errored if at least one bit in the frame is errored. Assuming a normal distribution the probability of there being exactly one errored bit in a 64 octet frame is:

$$P = p \times (1 - p)^{64 \times 8 - 1} \times (64 \times 8) \quad \text{where } p = \text{BER}$$

The probability that a frame contains exactly two errors is:

$$P = p^2 \times (1 - p)^{64 \times 8 - 2} \times (64 \times 8)(64 \times 8 - 1)/2$$

The probability of there being at least one bit errored in the 64 octet frame is:

$$P = 1 - (1 - p)^{64 \times 8}$$

From these formulas we can determine the following probabilities and FER:

Table A.1: FER/BER equivalence

Channel BER	1 bit error in frame	2 bit errors in frame	FER
1×10^{-6}	5×10^{-4}	1×10^{-7}	5×10^{-4}
1×10^{-8}	5×10^{-6}	1×10^{-11}	5×10^{-6}
1×10^{-10}	5×10^{-8}	1×10^{-15}	5×10^{-8}
1×10^{-12}	5×10^{-10}	1×10^{-19}	5×10^{-10}

A.2 FER equipment settings and measurement techniques (example)

Equipment used: IEEE 802.3 [5] compliant Ethernet frame test equipment.

The transmitting Ethernet port of the test equipment should be configured to the following settings:

- Mode: Single burst
- Count: 10 000 000 frames
- Length: Fixed, 64 bytes
- Interpacket Gap: 0,96 μ s for 100 Mbit/s, 9,6 μ s for 10 Mbit/s

FER can be calculated by the following formula after using the above measurements:

FER = 1 - (number of non-errored frames received)/(number of frames transmitted).

For example if 50 frames are lost or errored then the number of non-errored frames indicated by the test equipment will be 9,999,950.

The resulting FER = 1 - 9 999 950/10 000 000 = 5×10^{-6} .

Annex B (informative): Bibliography

- IEEE 1802.3 (1991): "Conformance Test Methodology for IEEE Standards for Local and Metropolitan Area Networks: Carrier Sense Multiple Access with Collision Detection (CSMA/CD) Access Method and Physical Layer Specifications".
- IEEE 1802.3d (1993): "Medium Attachment Unit (MAU) Conformance Test Methodology".
- ETSI EN 301 127 (V1.1.1): "Fixed Radio Systems Point-to-point equipment; High capacity digital radio systems carrying SDH signals (2 x STM-1) in frequency bands with about 30 MHz channel spacing and using Co-Channel Dual Polarized (CCDP) operation".
- ETSI EN 301 277 (V1.1.1): "Fixed Radio Systems; Point-to-point equipment; High capacity digital radio systems transmitting STM-4 or 4 x STM-1 in a 40 MHz radio frequency channel using Co-Channel Dual Polarized (CCDP) operation".
- ETSI EN 301 387 (V1.1.2): "Fixed Radio Systems; Point-to-point equipment; Plesiochronous Digital Hierarchy (PDH); Low and medium capacity digital radio systems operating in the frequency band 48,5 GHz to 50,2 GHz".
- ETSI EN 301 669 (V1.1.1): "Fixed Radio Systems; Point-to-point equipment; High capacity digital radio systems carrying STM-4 in two 40 MHz channels or 2 x STM-1 in a 40 MHz channel with alternate channel arrangement".
- ETSI EN 301 461 (V1.1.1): "Fixed Radio Systems; Point-to-point equipment; High capacity fixed radio systems carrying SDH signals (2 x STM-1) in frequency bands with 40 MHz channel spacing and using Co-channel Dual Polarized (CCDP) operation".

History

Document history		
V1.1.1	April 2000	Publication (as TS 101 785)
V1.1.1	April 2001	Publication
V1.2.1	October 2001	One-step Approval Procedure OAP 20020208: 2001-10-10 to 2002-02-08